





SF 487 K21 1921
Cornell University Library

Poultry culture sanitation and hygiene /



3 1924 000 001 788

vet

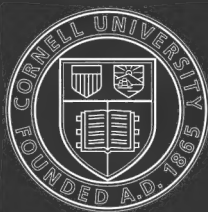

Cornell University Library

The original of this book is in
the Cornell University Library.

There are no known copyright restrictions in
the United States on the use of the text.

<http://www.archive.org/details/cu31924000001788>

POULTRY CULTURE SANITATION AND HYGIENE

BY

B. F. KAUPP, M. S., D. V. M.

POULTRY INVESTIGATOR AND PATHOLOGIST, ANIMAL INDUSTRY DIVISION,
NORTH CAROLINA EXPERIMENT STATION; PROFESSOR OF POULTRY SCIENCE,
NORTH CAROLINA AGRICULTURAL COLLEGE, WEST RALEIGH

SECOND EDITION, RESET

PHILADELPHIA AND LONDON

W. B. SAUNDERS COMPANY

1921

Copyright, 1915, by W. B. Saunders Company. Revised, entirely reset,
reprinted, and recopyrighted February, 1920

Copyright, 1920, by W. B. Saunders Company

Reprinted September, 1921

PRINTED IN AMERICA

PRESS OF
W. B. SAUNDERS COMPANY
PHILADELPHIA

FOREWORD TO SECOND EDITION

THE fact that a new edition has been made necessary in so short a time is a gratifying sign that this book has filled a need. In this second edition the book has been revised and partially rewritten to bring it down to date, for poultry work is constantly progressing.

B. F. KAUPP

WEST RALEIGH, N. C.

FOREWORD

It is to meet an ever-growing demand for a more accurate knowledge of the underlying fundamental principles which mean success in the poultry work that this volume has been prepared.

It is dedicated to the Poultry Science Courses of our Universities, Agricultural Colleges, Agricultural and other High Schools, to the Lower Grades Teaching Poultry Work, to the Institute workers and lecturers on Agriculture and Poultry Sanitation, to the Boys and Girls Poultry Clubs, to the Poultry Fancier and Poultry Producer, to the business-man who raises poultry on a town lot, and to the farmer who follows Poultry Culture as a side line.

The book consists of twenty-eight chapters. After a hurried look into the magnitude of the poultry industry and short study of the names of the various plumage parts, the student is made familiar with the terms used in poultry culture work, that he may be the better prepared to study the following pages. It is deemed necessary for one to know the names, breeds, and varieties of poultry and the fundamental principles underlying the selection, breeding, and fixing of the characters one breeds for.

A thorough discussion is given of hygiene and sanitation, taking into account the proper methods of ventilation, poultry-house construction, equipment, and the proper method of caring for same.

The importance of poultry enemies and means of ridding them of same is dwelt on, and includes animal enemies, vermin, and internal parasites, as well as contagious and non-contagious diseases.

An insight into the gross structure and the normal functions of the digestive organs, followed by a complete discussion of the processes of digestion, assimilation, and nutrition, is given. A complete discussion of feedstuffs used in compounding rations for poultry is given, as well as the method of computing rations and the proper methods of feeding breeding stock, laying stock, broilers, capons, turkeys, geese, ducks, pigeons, and for fattening work.

A discussion is given of diseases connected with the feeding of spoiled feeds, and a discussion of diseases of plants and seeds that may be injurious to birds consuming such diseased food.

Space is devoted to a discussion of the methods of finishing, dressing, refrigeration, packing, and selling of dressed poultry of all kinds, as well as to the proper care of eggs, including collecting, handling, grading, storing, packing, and shipping of same.

A thorough discussion of the methods of preserving and handling feathers, giving grades, methods of packing and shipping, as well as a discussion of the proper methods of caring for the droppings and their value as a fertilizer, and ways of using same to obtain the best results.

Considerable time has been devoted to the careful discussion of selecting eggs for sitting, their proper care, both natural and artificial methods of incubation and brooding. The proper way to sit a hen, the care of the sitting hen and properly housing her with her brood, as well as how to properly feed her and her brood.

Space is devoted to telling the boys and girls how they can construct cheaply their poultry club poultry house, and how to care for their flock.

Some time is spent in a discussion of the method of caponizing

and care of the capon, as well as preparing birds for the show-room.

A complete discussion of the anatomy, parasitism, diseases, their symptoms and treatment, forms a volume within itself, and the reader is referred to *The Anatomy of the Domestic Fowl, and Poultry Diseases*. For a complete discourse on standard breed requirements the student is referred to the *American Standard of Perfection*.

The author wishes to give credit for the article on Line Breeding to Mr. I. K. Felch, who has so kindly contributed this illustrated article; to Mr. Frederic Thayer for his idea of a modern poultry plant; to the Candee Incubator Company who have allowed the use of their material, as well as the Robert Essex Incubator Company, and to the various experiment stations and colleges for the use of their materials.

B. F. KAUPP.

WEST RALEIGH, N. C.,

CONTENTS

CHAPTER I

	PAGE
INTRODUCTORY.....	17
The Magnitude of the Poultry Industry.....	17
Outline for Course in College Instruction.....	19
The External Anatomy of the Fowl.....	20
Classification of Fowls.....	20
Glossary of Terms.....	21

CHAPTER II

BREEDS OF POULTRY.....	31
Breeds of Pigeons.....	34
The Cornell Study Outline.....	37
Variety Markings.....	43
History of the Breeds.....	45
The American Class.....	45
The Plymouth Rocks.....	45
The Wyandottes.....	48
The Rhode Island Reds.....	52
The Javas.....	54
The Dominiques.....	54
The Buckeyes.....	54
The Asiatic Class.....	55
The Brahmas.....	55
The Cochins.....	57
The Langshans.....	57
The Mediterranean Class.....	58
The Leghorns.....	58
The Minorcas.....	60
The Spanish.....	60
The Anconas.....	61
The Blue Andalusians.....	61
The English Class.....	61
The Dorkings.....	61
The Orpingtons.....	62

	PAGE
The Redcaps.....	64
The Sussex.....	64
The Cornish.....	65
The Polish Class.....	66
The Hamburg Class.....	67
The French Class.....	67
The Houdans.....	67
The Crevecœurs.....	68
The Continental Class.....	68
The Campines.....	68
Games and Bantams Class.....	69
BREEDS OF POULTRY—	
The Oriental Class.....	70
The Malays.....	70
The Sumatras.....	70
The Malay Bantams.....	71
The Ornamental Bantams Class.....	71
The Sebright Bantams.....	71
The Rose Comb Bantams.....	71
The Booted Bantam.....	71
The Brahma Bantams.....	73
The Cochin Bantams.....	73
The Polish Bantams.....	73
The Japanese Bantams.....	74
The Miscellaneous Class.....	74
The Sultans.....	74
The Sulkies.....	74
The Frizzles.....	74
The Turkey Class.....	74
The Turkeys.....	74
The Bronze.....	75
The White.....	75
The Narragansett.....	75
The Black.....	75
The Buff.....	75
The Slate.....	75
The Bourbon.....	76
The Duck Class.....	76
The Ducks.....	76
The Pekin.....	77
The Aylesbury.....	77
The Rouen.....	77

	PAGE
The Cayuga.....	77
The Call.....	77
The East India.....	77
The Crested.....	77
The Muscovy.....	77
The Indian Runner.....	77
The Swedish.....	78
The Orpington.....	78
The Penciled Runner.....	78
The Geese Class.....	78
The Geese Breed.....	78
The Toulouse.....	79
The Chinese.....	79
The African.....	79
The Embden.....	80
The Egyptian.....	80
The Wild or Canadian.....	80

CHAPTER III

THE PROBLEMS IN MATING AND IN EGG PRODUCTION.....	82
Selection of Birds for Breeding.....	87
Selection of the Cochins.....	88
THE PROBLEMS IN MATING, Selection of Birds for Breeding—	
Selection of the Brahmas.....	89
Selection of the Barred Plymouth Rocks.....	91
Selection of the Rhode Island Reds.....	92
Selection of the Wyandottes.....	93
Selection of the White Leghorns.....	94
Utility Classification.....	95
Fixing and Intensifying of the Egg-laying Characters.....	96
Rhythm in Egg Production.....	97
Distribution of Egg Production.....	98
Results of Breeding from Unselected Stock.....	100
Physical Indications in Egg Production.....	107
Key to Physical Index in Judging for Egg Production.....	110
Selection for Meat Quality.....	113
Judging for Utility.....	113
Mendelism.....	116
Line Breeding, Outcrossing, and Inbreeding.....	130
Pedigree Breeding.....	134

CHAPTER IV

	PAGE
FARM POULTRY PROBLEMS.....	138
Turkeys.....	148
Ducks.....	149
Geese.....	150
Guinea Fowls.....	150
Pigeons.....	151
Racing Homers.....	151
Squab Raising.....	151
Age of Birds Affecting Production.....	153
Housing.....	153
Interior Fixtures.....	154
Feeding.....	156
Pen Management.....	157
Selecting Breeders.....	157
Mating.....	157
Banding.....	158
Records.....	158
Cleaning.....	158
Killing, Cooling, Packing, Shipping.....	159

CHAPTER V

HYGIENE AND SANITATION.....	161
Water.....	161
Air.....	163
Respiration.....	165
Ventilation.....	167

CHAPTER VI

THE CONSTRUCTION OF POULTRY HOUSES.....	173
Construction of the Unit System House.....	189
Fencing Materials.....	203
Up-to-date Poultry and Fruit Farm.....	204
The Farm Flock.....	208

CHAPTER VII

SANITATION.....	210
Care of Buildings and Equipment.....	210
Vice.....	219
Pests.....	220
Molting.....	221

CHAPTER VIII

	PAGE
NON-CONTAGIOUS DISEASES.....	222

CHAPTER IX

CONTAGIOUS DISEASES.....	225
Blackhead.....	225
Fowl-cholera.....	228
White Diarrhea.....	230
Tuberculosis.....	232
Chicken-pox.....	233
Roup.....	234

CHAPTER X

EXTERNAL PARASITES.....	236
Lice.....	236
Chigger.....	239
Scaly Legs.....	241

CHAPTER XI

INTERNAL PARASITES.....	243
Round-worms.....	243
Large Round-worms.....	244
Small Round-worms.....	245
Gizzard Worm.....	246
Gape-worm.....	246
Tapeworms.....	248

CHAPTER XII

THE FEED PROBLEM.....	250
Plant Growth.....	250
Physiology of Digestion.....	253

CHAPTER XIII

NUTRITION.....	264
Mineral Requirement of Fowls.....	268
Essential Food Nutrients.....	272

CHAPTER XIV

DIGESTIBILITY AND NUTRITIVE RATIO.....	276
--	-----

CHAPTER XV

FEEDSTUFFS.....	280
Average Digestible Nutrients in Poultry Feeds.....	298
Poultry Feeds.....	303

	PAGE
CHAPTER XVI	
DISEASES CONNECTED WITH FEED.....	308
Spoiled and Discased Feeds.....	308
Diseases of Feeds.....	311
CHAPTER XVII	
RATIONS AND METHODS OF FEEDING.....	315
For Laying Hens.....	317
The Influence of Artificial Light on Egg Production.....	329
Chick Feeding.....	331
Turkeys and Poults.....	336
Ducks and Geese.....	337
Home-made Feeder and Exerciser.....	348
Other Rations.....	348
Finishing Birds.....	353
Cornell Fattening Ration.....	356
Commercial Fattening Establishments.....	360
CHAPTER XVIII	
BROILERS AND DRESSING OF FOWL.....	363
Dressed Poultry.....	368
Dressing Poultry.....	368
Poultry Box Measurements.....	382
Trussing.....	386
Boning Fowls.....	389
CHAPTER XIX	
THE CARE AND MARKETING OF FEATHERS.....	392
CHAPTER XX	
THE PRESERVATION OF POULTRY MANURE.....	397
CHAPTER XXI	
SELECTING EGGS FOR SITTING.....	400
CHAPTER XXII	
INCUBATION.....	405
The Small Incubator and Brooder.....	417
CHAPTER XXIII	
.....	417
THE MAMMOTH INCUBATOR AND BROODER.....	426
CHAPTER XXIV	
BROODING.....	438
Plans for a Home-made Brooder.....	443

PAGE

Construction of Fireless Brooder.....	445
Brooding on a Large Scale.....	450
Rearing Commercial Chicks.....	456
Shipping the Baby Chicks.....	457

CHAPTER XXV

MARKETING EGGS.....	459
Car Lot Shipment of Eggs.....	470
How to Load Cars of Eggs.....	470
Route of the Egg from the Producer to the Consumer.....	474
Refrigeration.....	476
Factors Affecting Cost of Marketing.....	477
Construction of Storage Houses.....	479
Egg Cases and Fillers.....	480
Collecting of Eggs on Cream Routes.....	481
Co-operative Marketing.....	482
Organizing an Egg Circle.....	483
How to Candle Eggs.....	493
Student's Laboratory Chart.....	494
Student's Candling Test.....	496
Judging Eggs.....	498

CHAPTER XXVI

CASTRATION OF THE BIRD (CAPONIZING).....	504
Spaying the Hen.....	510

CHAPTER XXVII

PREPARING BIRDS FOR THE SHOW-ROOM.....	511
Rearing Show Birds.....	514

CHAPTER XXVIII

THE CONSTRUCTION OF POULTRY HOUSE EQUIPMENT.....	516
The Construction of a Dry Mash Hopper.....	516
The Construction of a Trap-nest.....	517
The Construction of Storage Feed Bin.....	521
The Construction of Dropping Box.....	522
The Construction of Combination Sitting and Brooding Coop.....	522
Record Cards.....	525
Poultry Accountant Work.....	529

INDEX.....	557
------------	-----

POULTRY CULTURE, SANITATION, AND HYGIENE

CHAPTER I

INTRODUCTORY

THE 1910 census of the United States reports for North Carolina a total egg production in 1909 of 23,556,124 dozen, or an increase of 33.1 per cent. in ten years. These eggs were valued at \$4,256,769, or an increase valuation of 67.2 per cent. over 1899 or ten years previous. This ratio has practically been kept up throughout all the states.

That this estimate is far too low is shown by the fact that the total number of fowls on 223,808 North Carolina farms on April 15, 1910, was 5,054,000 leaving 25,990 farms not reporting any poultry raised in that year.

This report does not include poultry in cities, towns, or villages, which would greatly swell the amounts. It does not go into sufficient details in that it does not give the number which were chickens, turkeys, ducks, geese, guineas, and other birds.

Some means should be devised whereby fairly accurate data could be obtained of the entire poultry population, its products, its value, as well as the consumption and exports and imports of each state and their values.

The 1911 report of the United States Secretary of Agriculture places the national annual income from poultry products at \$750,000,000.

The state ranking first in poultry products on the farm is Rhode Island, where the average farm income from poultry is \$267.70.

The average state income from poultry products is \$5,227,-403, of which \$1,536,194 is credited to poultry carcasses sold, and \$3,691,239 is credited to eggs.

The average annual farm income from eggs for all the farms in the United States is \$60.57, while the income from carcasses is \$31.82.

Eggs are excellent human food, high in albuminous content and high in digestibility. The demand for eggs is growing faster than the increase in output.

In 1899 the average farm price was 11.15 cents per dozen for the whole United States, while in 1909 the average had advanced to 19.7 cents per dozen, and this year, 1919, it is safe to say that it will far exceed this sum.

Live and dressed poultry have made a corresponding increase in values.

The 1910 United States census report gives over 88 per cent. of all farms in the United States as keeping poultry. At that time there was 295,876,176 head, making an average of 6,038,-289 birds for each state or 53 birds to each farm, with a value per bird of 52 cents. It is significant that nearly 54 per cent. of the total number is found in ten states.

The volume of poultry on farms in the United States has increased over 18 per cent. in the last ten years.

Poultry growing is an adjunct of every properly conducted farm and of many back yards of town lots. No class of livestock is so universally raised as poultry. The flesh of fowl is highly nutritious and palatable and is relished by all. Eggs are very high in point of digestibility and are being used as a meat food more and more since the high price of other meat-food products.

The products of poultry rank next to those of the dairy or to the animals slaughtered for food. About one-sixth of the total value of animal products in the United States is credited to poultry. The contribution to the nation's wealth is more than half a billion dollars. The value of poultry is equal to the total value of barley, rye, buckwheat, broom-corn, rice, kaffir corn, flax, small fruit, grapes, orchard products, sugar-cane, and beets. The value of poultry is three times that of the wool crop. It is as great as the combined potato and oat crops.

OUTLINE FOR COURSE IN COLLEGE INSTRUCTION

1. History and scope of Poultry Industry.
Bibliography.
Nomenclature.
Origin, history, classification of breeds.
Judging for fancy; utility—meat and egg production.
Fitting fowls for exhibition.
Laboratory.
Plant exercises in breed study and judging. Routine plant work.
2. Hygiene and sanitation.
Elementary study of diseases and their control.
Poultry house construction and equipment.
Designing, building and remodeling houses.
Poultry farm management.
Distribution of labor, capital, general business management.
3. Feeds, feeding and fattening.
Care of plant flock, fattening market fowls.
Seminar
Advanced study of literature, thesis.
4. Incubation, brooding, rearing, breeding.
Laboratory.
Incubator practice.
Brooding practice.
Advanced study of literature on incubation and brooding. Thesis.
5. Study of markets and market conditions.
Marketing poultry.
Fattening, killing, picking, drawing, trussing, packing, refrigerating, and shipping dressed poultry.
Fattening and shipping live poultry.
Testing, candling, grading, packing, and shipping eggs.
Storage and preservation of poultry products.
Advertising and market accounting.
Food distribution and market organization.
6. Anatomy, physiology, and embryology.
7. Advanced study of diseases and their control.

The External Anatomy of the Fowl.—Before entering into the study of breeds and breeding, the student should be familiar with the external anatomy of the fowl, which is illustrated and shown in the accompanying figure.

Classification of Fowls.—Fowls are classified from a zoölogical standpoint as follows: Branch, Vertebrata; Class, Aves; and Order, Gallinæ.

In poultry science they are classified as follows: Class, Breed, and Variety.

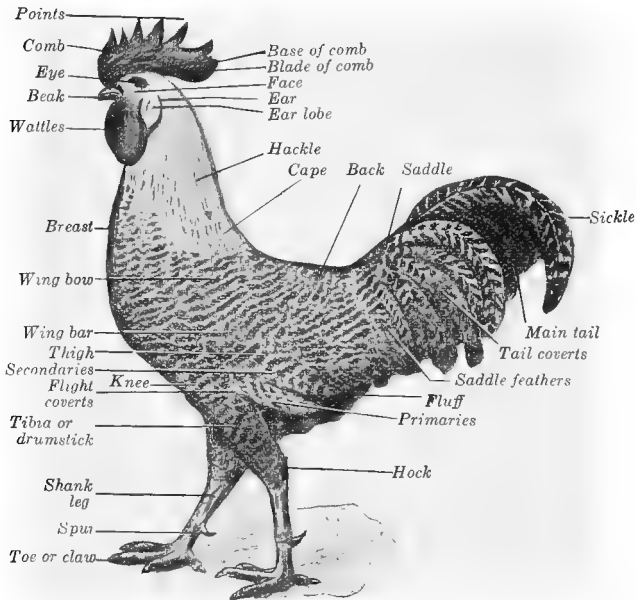

FIG. 1.—The external anatomy of the chicken.

The locality of the origin of the fowl is the basis upon which the class is named; thus, the Brahma originated in Asia and they are placed in a class called Asiatics.

The shape or conformation is the basis upon which the breed is named, as the Wyandottes possess a distinct type or shape.

The color and the feather pattern is the principal factor

upon which the variety is named. Thus the Silver-spangled Hamburg.

GLOSSARY OF TERMS USED IN THE TEXT

It is essential for the student to possess a sufficient knowledge of terminology to intelligently comprehend the text. The following gives a comprehensive glossary:

Abdomen. That part of the body between the thorax and the pelvis.

Albuminoid. The more complex forms of protein. They are insoluble in water or may be rendered so by heat.

Alfalfa. A leguminous plant used as roughage. Sometimes ground and placed as a part of the mash.

Alimentary Tract. The whole digestive tube, including the esophagus, crop, stomach, gizzard and intestines.

Antiseptic. An agent which prevents the growth of or destroys bacteria (germs).

Artificial Selection. The selection or mating of birds by the breeder to produce certain features which he desires to perpetuate.

Ash. The portion of feeds left after they have been burned. It contains the mineral matter.

Assimilate. The conversion of digested nutrients into fluid or solid substances of the body.

Balanced Ration. A combination of farm foods in such proportions and amounts as will nourish an animal or bird for twenty-four hours, with the least waste of food nutrients.

Barring. Stripes extending across feathers at right angles to its shaft.

Beard. A group of feathers pendent from the throat, as in Polish or Houdans. In male turkeys, a tuft of coarse, bristly hair, 4 to 6 inches long, projecting from the upper part of the breast.

Breeding Pen. Is usually made up of from 6 to 14 hens and a male bird. By some 4 hens and a cock is considered a pen.

Broiler. A bird weighing $2\frac{1}{2}$ pounds or less and from six to twelve weeks old.

Brood. All the young birds hatched and brooded by the mother at one time.

Calorie. The amount of heat required to raise 1 pound of water 4° F., or 1 kg. of water 1° C.

Cape. The short feathers on the back, shaped like a cape and lying underneath the hackle.

Capon. A male bird deprived of his generative organs for the purpose of improving the weight and quality of flesh.

Capacity. Extent of abdominal room for digestive and reproductive organs.

Carbohydrates. A group of nutrients containing hydrogen and oxygen in the proportions that they form water. They do not contain nitrogen. They include starches, sugars, gums, resins, and other similar substances.

Carriage. The attitude of the bird.

Caruncles. Small fleshy protuberances, as on the head of a turkey.

Carunculated. Having caruncles.

Casein. The protein portion of milk which is coagulated by acid or rennet.

Cavernous. The hollow protruding nostrils of the crested breeds.

Cellulose. The hard, woody portions of the plants and grains.

Chickens. The young of the domestic hen prior to the development of the adult plumage.

Chicks. Fowls less than one year old. In a restricted sense it is the young of the domestic hen until the sex can be determined.

Cock. A male fowl one year or more old.

Cockerel. A male fowl less than one year old.

Comb. The massive protuberance growing from the top of the fowl's head.

Concentrates. The more nutritious portion of the ration, such as corn, wheat, and oats. A large quantity of nutrients in a small bulk.

Condition. The state of a bird as regards health, order of plumage, and cleanliness and flesh.

Contagion. That which is contagious.

Corn. **Indian Corn.** A grain used in poultry feeding.

Cow-pea. A leguminous plant, the seeds of which may be used in poultry feeding.

Crest. A tuft of feathers on the top of a fowl's head.

Crop. An expansion of the esophagus, just below its center. It is a storehouse for food till needed.

Crude Fiber. The framework forming the walls of the cells and framework of the plant. Cellulose.

Cushion. The mass of fluffy feathers at the rear of the bird and partly covering the tail.

Diastase. A ferment existing in seeds which makes germination possible by causing the starch to be changed into sugar under certain conditions.

Digestible Matter. The part of the food-stuffs that can be brought into solution by the digestive juices.

Digestible Nutrients. The portion of the food-stuff that can be digested by the birds.

Digestive Tract. Alimentary tract.

Disinfection. A complete destruction of all germs.

Disinfest. To rid of parasites.

Disqualification. A serious defect or deformity which will not allow it to enter competition as a pure-bred exhibition fowl.

Down. The first hairy covering of chicks. Sometimes tiny tufts of down develop on the shanks. It is considered a feather if a quill and web can be recognized; otherwise it is down.

Drake. A male bird of the duck breed.

Dry Matter. The portion of the food-stuff that remains after the water has been driven off by heat.

Dubbing. Cutting off the comb is called dubbing and the comb so cut off is dubbed.

Duck-footed. When the hind toe points forward the bird is said to be duck-footed.

Ducklings. Young ducks prior to the development of feathers.

Ear-lobes. The folds of bare skin just below the ears.

Emulsion. A fine, mechanical suspension of fat or other substances.

Ensilage. Forage preserved in a silo.

Epiornithics. An outbreak of contagious disease among birds.

Ergot. A fungus parasitic on the seeds of cereals and grasses.

Established Points. Certain characteristics of a variety which, through length of time and breeding, have become so fixed that the progeny have these points established.

Ether Extract. The material that can be dissolved from a water-free feed-stuff, by means of ether.

Excrement. The indigestible matter of feeds voided by birds.

Eye-ring. The outer edge of the eyelids.

Fancy and Exhibition Poultry. Fowls kept and bred for their fancy points or particular qualities mainly to exhibit or keep as a hobby; the utility side may be taken into consideration, but is of a secondary nature.

Face. The nude skin on the head, around the eyes.

Feather. Consists of a web supported by a quill.

Flight Coverts. The short feathers located at the base of the wing primaries.

Flights. Primary wing feathers, for the most part folded out of sight during rest.

Frizzled. The descriptive term applied to fowls having their feathers turned in the opposite direction to that which is usual.

Furnished. In full feather—when the hackle and sickle feathers are developed.

Fluff. The soft downy part of the feathers, and is also applied to the soft feathers about the vent.

Foot-ton. The amount of work required to raise one ton one foot high.

Footings. Term used to describe foot or leg feathering in Cochins, Brahmas and Langshans.

Frosting. In spangled or penciled varieties showing an edging of color.

Fryer. A young chicken weighing 2½ to 4 pounds.

Fresh Blood. The introduction into a breeder's yard of either male or female birds either totally unrelated to or a sub-strain of his own for some special purpose, generally to improve the stamina of a strain where inbreeding is resorted to.

Germicide. An agent destroying germs.

Gills. The wattles.

Glucose. Grape-sugar found in honey, fruit, etc.

Glycogen. An animal starch manufactured by the liver from the digested carbohydrates absorbed from the digestive tract.

Gram. A metric weight, 15.5 grains.

Green Bone. Bone that is fresh-cut, not cooked.

Green Goose. A gosling that is ready to be, or has been, "killed off the grass."

Gullet. The passage in the neck through which food passes to the stomach. Esophagus. The loose part of the lower mandible.

Hackle. The neck feathers of either sex.

Hatchability. The number of fertile eggs capable of hatching.

Hangers. The shorter sickle-like feathers at base of cock's tail.

Hard Feathered. Feathers having a hard, close-fitting appearance—on birds carrying little fluff.

Heavy Breeds. The sitting, as distinct from the non-sitting varieties.

Hen. A female bird over one year old.

Hen Feathered. A male bird without sickle feathers and thus resembling a hen.

Hock. The first joint above the foot.

Intestine. That part of the alimentary tract extending from the gizzard to the cloaca.

Jaw. The upper or lower mandibles.

Kilogram. Abbreviated Kilo. A metric weight amounting to 2.2 pounds.

Knee-joint. A term sometimes applied (though wrongly) to the hock-joint.

Laced. A feather in which the body differs from the edge color.

Lacteal. Minute tube of the villus for the purpose of absorption of the chylous or milky emulsified fluid fat from the intestines.

Lay-Bones. The pubic bones.

Lateral Sternal Processes. The thin flat bones projecting backward from the body of the sternum or breast bone.

Leaf-comb. Consists of two small single combs serrated at the free borders.

Leg. The shank, tibia, and thigh.

Leg-feathers. As in Asiatics, where the feathers grow on the outside of the shank.

Legumes. A plant that belongs to the family Leguminacea. A pod-bearing plant, as the clover, beans, and peas.

Lesser Sickles. Tail coverts or the sickle feathers, except the two central large ones.

Levulose. Invert sugar obtained from dextrose.

Lopped Comb. The comb falling over to one side.

Lymph. The colorless fluid of the lymph-vessels.

Lymphatic System. A system of tubes or vessels like blood-vessels, carrying the lymph.

Mash. A mixture of ground grains or of by-products fed either dry or wet.

Mating. The putting together of birds by selection for breeding purposes so as to accentuate the good points and correct the bad points of such parents mated.

Maintenance Ration. An amount of food sufficient for a resting animal, neither loosing or gaining in weight, for twenty-four hours.

Mangles. A root crop—the Beta Vulgaris.

Masticate. To crush or grind food with teeth.

Mealy. In buffs, where the color is broken by specks of lighter color appearing as if meal had been sprinkled on the feather.

Metabolism. The processes in the living cells, consisting of anabolism—building up, and katabolism—tearing down.

Meter. A metric measure equaling 3.28 feet.

Mineral Matter. The ash of the food.

Mossy. Dark irregular penciling appearing in the center of laced feathers.

Mottled. Surface of plumage marked with spots of different colors.

Muffs. Tufts of feathers on the face below the eyes.

Natural Selection. The mating of birds of their own will.

Nitrogen-free Extract. The food-stuff remaining after the crude fiber and fat have been removed. It includes starches, sugars, and gums.

Nitrogenous Substances. Any food-stuff containing nitrogen.

Nutrients. Groups of substances, as protein and carbohydrates, that are capable of nourishing an animal.

Nutritive Ratio. The proper proportion of protein to carbohydrates and hydrocarbons in a feed or ration. The fat is reduced to a carbohydrate equivalent by multiplying by 2.25.

Oil Meal. Linseed-oil cake reduced to fineness by grinding.

Organic Matter. That part of the food-stuff destroyed by burning.

Parasiticide. An agent killing parasites.

Parasitism. Being infested by parasites, as lice and chiggers.

Parti-colored. A feather presenting two or more colors.

Pea Comb. A triple comb presenting the appearance of three single combs placed parallel to each other and joined at the rear and base and showing serrations at the free margins.

Pen. Four females and a male.

Penciling. Small stripe-like markings on a feather. They may follow the outline of the feather or run crosswise.

Peppered. A mealy appearance produced by a splattering with black or gray.

Pepsin. A digestive ferment found in stomach juices.

Pelvic Arch. The arch formed by the overreaching pelvic bones.

Plumage. The feathers of a fowl.

Poularde. A pullet deprived of the power of producing eggs, with the object of greater size.

Poult. A young turkey. After the sexes can be determined they are then called cockerels or pullets.

Poultry. Domestic fowls.

Poultry Breeder. One who regulates the reproduction of poultry.

Poultry Keeper. One who keeps poultry without regard to skill, experience, or success.

Poultry Raiser. One who hatches and rears poultry.

Poultryman. A poultry keeper who is an expert.

Primaries. The wing-flight feathers, which are nearly hidden when the wing is closed.

Protein. The nitrogen, containing food nutrient.

Provender. Forage or grain feed of any kind.

Progeny. The offspring or young birds of birds mated.

Puberty, Age of. The age at which a pullet commences to lay.

Pubic Bones, Also Called Lay-bones. The rib-like bones lying at the lower edge of the pelvis, or pelvic arch.

Pullet. A female fowl less than one year old.

Quill. The stem of the feather.

Respiration. The act of breathing.

Roaster. A chicken weighing 4 or more pounds.

Rooster. A male fowl.

Rose Comb. A solid, low, thick comb, terminating posteriorly in a spike. The top is covered with small rounded points.



FIG. 2.—Head of a Single Comb White Leghorn Male showing defects: 1, side sprig; 2, fish-tail; 3, crooked beak; 4, uneven serration.

Roughage. The coarse portion of a ration.

Rutabaga. A Swedish turnip. A root crop used in winter feeding to supply succulent feed.

Saddle. The posterior part of the back and that part just anterior to the tail.

Saddle Feathers. The feathers covering the saddle.

Saddle Hackle. The narrow, long-pointed feathers developing from the saddle.

Secondaries. The large feathers that grow on the second joint of the wing.

Serrated. Saw-like notching.

Serration. The projections of the serrated comb.

Shaft. The stem or supporting part of the feather.

Shafting. The shaft of the feather, being either darker or lighter than the web of the feather.

Shank. The part of the leg extending from the foot to the hoek. The scaly portion of the leg.

Sickles. The two central long curved tail feathers of the male.

Side Sprigs. Spike-like growths from the side of the comb.

Silage. The feed stored in a silo.

Silo. An air-tight structure in which green feed is stored for winter feeding.

Single Comb. A single leaf-like structure raising from the top of the head which in the male should stand erect. It is provided with spikes at the free border.

Solid Color. Of one color—that is, a uniform color unmixed with other colors.

Sorghum. A plant possessing a stalk like corn and containing much sugar. The seeds growing on the top are sometimes used in poultry feeding.



FIG. 3.—The head of a white Minorca cock, showing at *a* the so-called thumb mark.

Soy Bean. A leguminous plant, the seeds of which are sometimes used in poultry feeding.

Spangle. The colored spot at the free extremity of a spangled feather.

Spangled. Consisting of spangled feathers.

Spring Chicken. A young bird weighing over 2 pounds.

Spur. The horn-like rounded or pointed growth from the inferior third of the shank.

Squab. A young pigeon.

Squab Broiler. A young chicken weighing from $\frac{3}{4}$ to $1\frac{1}{4}$ pounds.

Squirrel Tail. A tail projecting forward toward the head.

Storage Egg. A storage egg is one held in cold storage at a temperature of 45 degrees or lower for a period of thirty days or more.

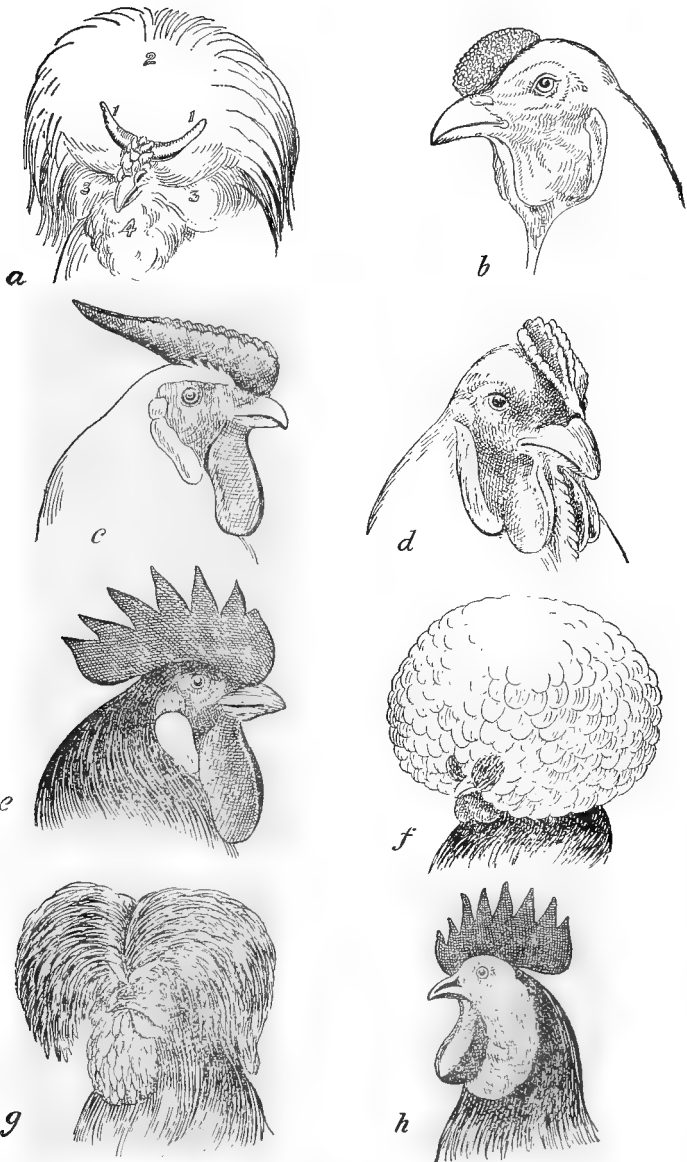

FIG. 4.—Types of combs and faces: *a*, The V-shaped comb at 1, also showing at 2 the crest; 3 the muffs; 4, the beard. *b*, The strawberry comb. *c*, The rose comb. *d*, The pea comb. *e*, Single comb and white ear-lobes. *f*, Crest of female. *g*, Crest of male. *h*, A white face.

Stag. A young male. Applied to game birds.

Stewing Chicken. A chicken weighing about 3 pounds.

Stipple. Small dotted or speckled appearance of a feather.

Strain. Successive breeding of one variety of fowls by one fancier always using the same blood line.

Strawberry Comb. One resembling a strawberry.

Stock. Usually spoken of in connection with fowls kept for breeding purposes; that is, "breeding stock" or "stock birds."

Succulent Feed. A feed containing much water, as sprouted oats, cabbage, and root crops.

Symmetry. The standard shape and harmony of proportions of a fowl.

Tail-coverts. The curved feathers to the side and in front of the tail.

Tail Feathers. The straight stiff feathers of the tail are known as the main tail feathers.

Thighs. The portion of leg above the knee. The femoral region.

Thumb Mark. A depression at the side of the comb. It has somewhat the appearance of an impression made by the thumb.



FIG. 5.—A vulture hock.

Throwing Back. A return by the offspring to the original or natural type of the parent.

Toe Feathering. Feathers on the toes.

Trio. Two females and one male.

Twisted Comb. An irregular-shaped comb.

Twisted Feather. A feather with a twisted shaft.

Typical. Of correct type.

Under Color. The color of the under or invisible portion of the plumage.

Utility Poultry. Principally laying and table birds kept and bred for the production of eggs and table fowls, the aim in the disposal of such being to earn a livelihood and make profit.

Variety. A subdivision of the breeds.

Vacation. Period of few days during which a hen stops laying and casts feathers. Then she stops casting feathers, and grows feathers to

replace those cast and returns to laying. A hen does not lay and cast feathers at the same time but may lay and grow feathers at the same time.

Vent. The anal opening.

V-shaped Comb. Shaped like a V.

Vulture Hock. Stiff feathers projecting back from the hock.

Wattles. The flat pendulous growths hanging from the base of the jaws.

Web. The barbed portion of the feather.

Wing Bar. The middle portion of the wing.

Wing Bay. A triangular portion just below the wing bar.

Wing Bow. The upper portion of the wing.

Wing-coverts. Small feathers covering the base of the secondary feathers.

Wing-fronts. The anterior edge of the wing.

Wing-points. The ends of the primaries.

Wry-tail. A tail turned to one side.

CHAPTER II

THE BREEDS OF POULTRY

THE National Organization of Poultry Fanciers is known as the American Poultry Association. This organization recognizes certain breeds that with the proper mating always breed true to type and feather pattern. The book of recognition is known as the American Standard of Perfection.

There are 15 classes, 58 breeds and 149 varieties belonging to this standard, as follows:

Class	Breed	Variety
American.	Plymouth Rocks:	Barred.
		White.
		Columbian.
		Partridge.
		Silver Penciled.
		Buff.
	Wyandottes:	Columbian.
		Partridge.
		Buff.
		Golden.
		Silver.
		White.
Rhode Island Reds:	Black.	
	Silver Penciled.	
	Rose Comb.	
	Single Comb.	
Javas:	Mottled.	
	Black.	
Asiatic	Dominiques:	Rose Comb.
	Buckeyes:	Pea Comb.
	Brahmas:	Dark.
		Light.
	Cochins:	Black.
		Partridge.
		Buff.
	Langshans:	White.
		White.
		Black.

Class	Breed	Variety	
Mediterranean.	Leghorns:	Single Comb White.	
		Rose Comb White.	
		Single Comb Brown.	
		Rose Comb Brown.	
		Single Comb Buff.	
		Rose Comb Buff.	
		Single Comb Black.	
		Silver.	
		Minorcas:	Single Comb White.
			Single Comb Black.
Rose Comb Black.			
Spanish:	Rose Comb White.		
	White Faced Black.		
Anconas:	Single Comb.		
	Rose Comb.		
English.	Blue Andalusians.		
	Orpingtons:	Single Comb Buff.	
		Single Comb White.	
		Single Comb Black.	
	Dorkings:	Colored.	
		White.	
		Silver Gray.	
	Redcaps:	Rose Comb.	
	Sussex:	Speckled.	
Cornish:	Red.		
	White Laced Red.		
	Dark.		
Polish.	Polish:	White.	
		White Crested Black.	
		Bearded Silver.	
		Bearded Golden.	
		Bearded White.	
		Buff Laced.	
		Non-bearded Silver.	
		Non-bearded Golden.	
		Non-bearded White.	
		Silver Spangled.	
Golden Spangled.			
Hamburg.	Hamburgs:	Golden Penciled.	
		Silver Penciled.	
		White.	
		Black.	
		Mottled.	
		White.	
		Black.	
French.	Houdans:	Golden.	
	Crevecœurs:		
	La Fleche:		
	Faverolle:		

Class	Breed	Variety	
Continental.	Campines:	Silver.	
		Golden.	
Game and Bantam.	Games:	Black.	
		White.	
		Birchen.	
		Red Pyle.	
		Golden Duckwing.	
		Silver Duckwing.	
		Brown Red.	
		Black Breasted Red.	
		Game Bantams:	White.
			Black.
	Birchen.		
	Red Pyle.		
	Golden Duckwing.		
	Silver Duckwing.		
	Brown Red.		
	Oriental.	Malays:	Black Breasted Red.
		Sumatras:	Black.
Ornamental Bantam.	Malay Bantams:	Black Breasted Red.	
	Sebrights:	Silver.	
		Golden.	
	Rose Comb:	Black	
		White.	
	Booted:	White.	
	Brahma:	Dark.	
		Light.	
	Cochins:	Black.	
		White.	
		Partridge.	
		Buff.	
	Polish:	Buff Laced.	
		Bearded White.	
		Non-bearded.	
Miscellaneous.	Japanese:	Black.	
		White.	
		Black Tailed.	
		Gray.	
		Mille Fleur Booted.	
	Sultans:	White.	
	Silkies:	White.	
	Frizzles:	Any Color.	
	Turkey.	Turkeys:	Bronze.
			Bourbon.
		Slate.	
		Buff.	

Class	Breed	Variety
Turkey.		Black.
		White.
Duck.		Narragansett.
	Pekin:	White.
	Swedish:	Blue.
	Orpington.	Buff.
	Indian Runner.	
	Penciled Runner.	
	Muscovy:	White.
		Colored.
	Aylesbury:	White.
	Rouen:	Colored.
	Cayuga:	Black.
	Call:	White.
		Gray.
	East India.	Black.
	Crested:	White.
	Toulouse.	Gray.
	Chinese:	White.
	Brown.	
African:	Gray.	
Embsden:	White.	
Egyptian:	Colored.	
Wild or Canadian:	Gray.	

NON-STANDARD BREEDS

Guinea.	Guinea:	White.
		Lavender.
		Pearl.

BREEDS OF PIGEONS

I. LARGE PIGEONS

The large breeds of pigeons are not very numerous and are as follows:

Runts.

English pouters.

English carriers.

This class might also be said to include the other larger breeds which are used, more or less, for squab breeding purposes, although they are not as large as these three mentioned breeds. They are:

Carneaux.	Squab Homers.
Montabans.	Strassers.
Hungarian Hens.	Polish lynx.
Maltese.	White kings.
Dragoons.	Mondaines.

Some of the foregoing are now also being bred strictly for fancy points.

II. MEDIUM AND SMALL PIGEONS

Next comes the large class of medium sized and small pigeons which are so difficult of classification because they generally have no one particular trait, and more often have two traits of interest. Hence it is almost impossible to select a basis for their classification. We will, however, list those with the most points, first, and let the others follow after.

Barbs. One of the oldest and rarest of high class pigeons.

Fantails. Perhaps our oldest of fancy pigeons.

Jacobins.

Scanderoons. A rare Oriental breed.

Pouters: *a*, Pigmy, the smaller English pouter; *b*, French; *c*, Brunner; *d*, Bohemian; *e*, Munster; *f*, Elster; *g*, Pommeranian; *h*, Norwich; *i*, Holland.

Owls. *a*, English; *b*, African and *c*, Chinese.

Turbits.

Oriental frills. *a*, Satinettes; *b*, Blondinettes *c*, Bluettes; *d*, Dominos.

Magpies. These are now a distinct breed although they were formerly one of the members of the tumbler family.

Trumpeters: *a*, Russian, which might be said to belong to the large breeds used for squab breeders, but they are usually kept strictly for fancy, so they properly belong here. *b*, English; *c*, Dutch; *d*, Altenberg and *e*, Priests.

Swallows (chiefly bred and admired for their contrast of color).

Archangels.

Nuns.

Helmets.

Larks.

Modena.

Florentine,

Ice.

Porcellan.

Frillbacks.

Starlings.

Mooreheads.

Tumblers.

These latter are placed here because they really belong to the flying or performing pigeon class, and were so raised originally. But as most tumbler breeders live in cities and cannot give their birds full liberty, the tumbling trait of character has not been retained and the variety is now mostly bred for fancy points. Tumblers are of three chief classes: *a*, English; *b*, German, and *c*, Oriental, and this variety was formerly named such because when flying they develop a habit of turning over backward one or more times. Some of them still do this, especially Orientals, which are sometimes commonly called "Rollers" because their backward turning often results in their rolling backward from high up in the air to the ground. The English tumblers are divided into the long and short faced, although the tendency of modern judges is to favor the long faced birds which tend toward the short faced characters as to shape of head and beak. The long faced birds are again divided into the clean leg and the muffed, or feather legged or feather footed. And, as they are all bred in several colors, and some of these colors have certain markings, it will be seen that they form a very numerous family, and often make a numerous collection at our pigeon shows.

The Germans divided their tumblers into three classes according to the length of the beaks, thus: *a*, long beaked; *b*, middle beaked, meaning middle length beak, and *c*, short beaked. The long beaked were mostly flyers and were all clean footed. The middle beaked were bred for both flying and for fancy; and were bred with clean feet, also feather footed. The short faced were all grouse footed, whereas the English short faced were all clean footed. The English have bred a modified Oriental roller which they call the Birmingham roller, and which is strictly a performing bird.

Homers. These birds also occupy a double position and some of them really belong to the fancy class, while others are kept solely for their performance. The fancy kinds are the *a*, English show homer, which is almost universally used for show purposes, although some have been trained as fliers and have given a good account of themselves. The same is true of the next class, *b*, exhibition-working homer, of which

more are used for flying in races. This is also true of the *c*, Antwerp, which is both used for show and flying. And then the true *d*, flying homer which can be of any color and shape, although fliers are recognizing that the best performers usually have certain shape-characters which they favor.

High flyers. By many these are classed as tumblers, but they do not tumble, and are kept and admired for their desire to attain high altitudes and long hours of flight.

Birmingham rollers, as mentioned above.

Cumulets.

Tipplers.

Perhaps it might be well to say that while pigeons belong to the great family of Aves, they have a trait of character which distinguishes them from all other birds. They are the only birds which drink by holding their beaks in the water and swallow the water without removing the beak; and they are also the only birds which feed their young with a milk which is secreted from the inner lining of the membrane of the crop, and which secretion is present only after they have incubated a pair of eggs.

While there are some wild pigeons of India which closely resemble our domesticated breeds, such as the bleeding heart pigeon which is sometimes seen in our public parks, there are also a few other rare kinds that have not been domesticated.

THE CORNELL STUDY OUTLINE

The student will find the following outline, which was designed by Cornell Poultry Department, useful in the superficial study of breeds.

CLASSIFICATION OF BREEDS OF FOWLS

I. Asiatic class:

A. General characteristics:

1. Large, heavily feathered, phlegmatic, brown eggs, good mothers, not inclined to fly, red ear-lobes, four toes, feathered shanks.

B. Breeds:

1. Brahma—Pea comb.
2. Cochinchina—single comb, yellow skin.
3. Langshan—single comb, white or gray skin.

II. American class:

A. General characteristics:

1. Medium to large, well feathered (not as profusely as the Asiatic), more active than Asiatic, brown eggs, good mothers, yellow skin, red ear-lobes, four toes, clean shanks.

B. Breeds:

1. Plymouth Rock—single comb.
 2. Wyandotte—rose comb.
 3. Rhode Island Red—single and rose comb, characteristic color.
 4. Dominique
 5. Java
 6. Buckeye
- } Not common.

III. Mediterranean class:

A. General characteristics:

1. Smaller and closer feathered than American class, very active, usually poor mothers, lay white eggs, can fly well, white ear-lobes, four toes, clean shanks.

B. Breeds:

1. Leghorn—single or rose comb, yellow skin.
2. Minorca, single or rose comb, white skin.
3. Ancona—single comb, yellow skin, plumage mottled.
4. Blue Andalusians—characteristic color.
5. White Faced Black Spanish—characteristic face, not common.

IV. English:

A. General characteristics:

1. Medium to large, well feathered (not as profusely as the Asiatic), more active than Asiatic, good mothers, white skin, clean shanks.

B. Breeds:

1. Dorking—five toes, not common.
2. Orpington—four toes, single comb, white skin, buff, black, and white.
3. Red Cap—not common.
4. Sussex, single comb, ear-lobes red.
5. Cornish, pea comb, ear-lobes red.

Other classes may be studied briefly if time permits.

CLASSIFICATION OF VARIETIES OF FOWLS

I. Shanks feathered.	Breed.
A Shanks, black.	
A1 Ear-lobes, red.	
C2 COMB, SINGLE.	
A3 plumage, black.	
A4 large.	
A5 skin, white.	Black Langshans.
B5 skin, yellow.	Black Cochins.
B4 small.	Black Cochin Bantams.
B <i>Shanks, Slate.</i>	
A1 Ear-lobes, red.	
C2 COMB, SINGLE.	
A3 plumage, white.	White Langshans.
E <i>Shanks, Yellow.</i>	
A1 Ear-lobes, red.	
A2 COMB, PEA.	
A3 plumage, white with black trimmings.	
A4 large.	Light Brahas.
D4 small.	Light Brahma Bantams.
B3 plumage, black and white, mostly black, hen silver penciled.	
A4 large.	Dark Brahas.
B4 small.	Dark Brahma Bantams.
A1 Ear-lobes, red.	
C2 COMB, SINGLE.	
A3 plumage, buff.	
A4 large.	Buff Cochin.
B4 small.	Buff Cochin Bantams.
B3 plumage, red with black stripes, hen penciled black.	
A4 large.	Partridge Cochin.
B4 small.	Partridge Cochin Bantam.
C3 plumage, white.	
A4 large.	White Cochin.
B4 small.	White Cochin Bantam.
II. Shanks non-feathered.	
A shanks, black.	
A1 Ear-lobes, red.	
A2 COMB, PEA.	
A3 plumage, lustrous green.	Black Sumatras.
B2 COMB, ROSE.	
A3 plumage, black.	Black Wyandottes.

C2 COMB, SINGLE.	
A3 plumage, black.	Black Orpingtons.
B3 plumage, white and Black.	
A5 skin, white.	Black Javas.
B5 skin, yellow.	Birchen game.
F2 COMB, "V."	
A3 plumage, black.	Crevecoeurs.
B1 Ear-lobes, white.	
B2 COMB, ROSE.	
A3 plumage, black.	R. C. Black Monorcas.
A4 large.	
A5 skin, white.	
B5 skin, blue.	Black Hamburgs.
B4 small.	R. C. Black Bantams.
C2 COMB, SINGLE.	
A3 plumage, black.	S. C. Black Minorca.
B <i>Shanks, Slate.</i>	
A1 Ear-lobes, red.	
B2 COMB, ROSE.	
A3 plumage, golden.	Golden Sebright Bantam.
B3 plumage, silver.	Silver Sebright Bantam.
A2 COMB, SINGLE.	
A3 plumage, black, mottled with white.	Mottled Java.
B1 Ear-lobes, white.	
B2 COMB, ROSE.	
A3 plumage, golden and penciled.	Golden Penciled Hamburg.
B3 plumage, golden and spangled.	Golden Spangled Hamburg.
C3 plumage, silver and penciled.	Silver Penciled Hamburg.
D3 plumage, silver and spangled.	Silver Spangled Hamburg.
E3 plumage, white.	White Hamburg.
F3 plumage, red, black.	Red Caps.
C2 COMB, SINGLE.	
A3 plumage, slaty blue.	Blue Andalusians.
E2 COMB, "V" SHAPED.	
A3 plumage, golden.	
A7 bearded.	Golden Bearded Polish.
B7 non-bearded.	Non-bearded Golden Polish.
B3 Silver.	
A7 bearded.	Bearded Silver Polish.
B7 non-bearded.	Non-bearded Silver Polish.

II. Shanks non-feathered.

C3 plumage, white.

A4 large.

A7 bearded.

B7 non-bearded.

B4 small.

A7 bearded.

B7 non-bearded.

D3 plumage, buff laced.

A4 large.

B4 small.

C Shanks, Willow-green or Willow.

A1 Ear-lobes, red.

C2 COMB, SINGLE.

A3 plumage, black and red.

A4 large.

B4 small.

B3 plumage, black and white.

A4 large.

B4 small.

C3 plumage, black, golden,
and white.

A4 large.

B4 small.

D Shanks, White or Pink.

A1 Ear-lobes, red.

C2 COMB, SINGLE.

A3 plumage, buff.

B3 plumage, black, white,
and straw.

C3 plumage, silver and gray.

D3 plumage, white.

A4 large.

A6 toes 4.

B6 toes 5.

B4 small.

B1 Ear-lobes, white.

B2 COMB, ROSE.

A3 plumage, white.

C2 COMB, SINGLE.

A3 plumage, white.

E2 COMB, "V" SHAPED.

A3 plumage, mottled black
and white.*E Shanks, Yellow.*

A1 Ear-lobes, red.

Bearded white Polish.

Non-bearded white Polish.

Bearded White Polish Bantam.

Non-bearded White Polish Ban-
tam.

Buff Laced Polish.

Buff Laced Polish Bantam.

Black Breasted Red Game.

Black Breasted Red Game

Black Breasted Red Game.

Silver Duckwing Game Bantam.

Silver Duckwing Game Bantam.

Golden Duckwing Game.

Golden Duckwing Game Ban-
tam.

Buff Orpingtons.

Colored Dorking.

Silver-gray Dorking.

White Orpington.

White Dorking.

Booted White Bantams.

R. C. White Bantams.

White Minorcas.

Houdans.

A2 COMB, PEA.

A3 plumage, red.

B3 plumage, greenish black.

C3 plumage, white.

D3 plumage, white laced,
red.

Buckeyes.

Dark Cornish.

White Cornish.

White Laced Red Cornish.

II. Shanks non-feathered.

B2 COMB, ROSE.

A3 plumage, buff.

B3 plumage, golden,

C3 plumage, partridge.

D3 plumage, silver.

E3 plumage, silver penciled.

F3 plumage, white.

G3 plumage, white and dark.

H3 plumage, barred.

I3 plumage, red.

Buff Wyandottes.

Golden Wyandottes.

Partridge Wyandottes.

Silver Wyandottes.

Silver Penciled Wyandottes.

White Wyandottes.

Columbian Wyandottes.

Dominiques.

R. C. Rhode Island Red.

C2 COMB, SINGLE.

A3 plumage, barred.

B3 plumage, buff.

C3 plumage, white with
dark parts.

D3 plumage, partridge.

E3 plumage, white.

A4 large.

B4 small.

F3 plumage, red.

G3 plumage, black.

H3 plumage, black and
white.I3 plumage, red, white,
and bay.

Barred Plymouth Rocks.

Buff Plymouth Rocks.

Columbian Plymouth Rocks.

Partridge Plymouth Rocks.

White Plymouth Rocks.

White Jap Bantams.

Rhode Island Red.

Black Jap Bantams.

Black Tailed Jap Bantams.

Red Pile Game.

D2 COMB, STRAWBERRY.

A3 plumage, dark brown.

A4 large.

B4 small.

Black Breasted Red Malay.

Black Breasted Red Malay.

B1 Ear-lobes, white.

B2 COMB, ROSE.

A3 plumage, white.

B3 plumage, buff.

C3 plumage, brown.

C2 COMB, SINGLE.

A3 plumage, white.

B3 plumage, buff.

C3 plumage, black.

D3 plumage, brown.

E3 plumage, silver.

F3 plumage, mottled black
and white.

White Leghorns.

Buff Leghorns.

Brown Leghorns.

White Leghorn.

Buff Leghorn.

Black Leghorn.

Brown Leghorn.

Silver Leghorn.

Anconas.

VARIETY MARKINGS¹

Columbian.—The neck hackle, smaller tail coverts, and saddle feathers at the root of the tail have a greenish-black center with a white edging. The primary and secondary wing feathers are black with a lower edge of the inferior web white. The main tail and sickle feathers are black. The balance of the surface is white. The under color is bluish-white.

Partridge.—Male: Neck hackle, back, saddle feathers, and tail coverts black edged with brilliant red. The primary and secondary feathers are black with the lower edge of the lower web reddish-bay. The main tail and sickle feathers are black. Female: The surface plumage of the hen shows each feather a mahogany-brown with three distinct black outlines conforming to the shape of the feather.

Penciled (Silver).—Male: The neck hackle and saddle feathers are greenish-black with an edging of white. The wing bow and back are white. The primary and secondary wing feathers are black with edging of white on lower part of lower web. The balance of the surface plumage is black. Female: Hackle similar to that of the male. Balance of surface color gray with three dark pencilings conforming to the shape of the feather.

Buff.—The surface color is a golden buff with a lighter under color. The wing bow, saddle and neck are a glossy golden buff.

White.—Pure white free from brassiness.

Barred.—Applied to a variety of Plymouth Rocks. Alternate bands of white and black.

Silver.—Applied to a variety of Wyandotte in which the feathers of the hen in their surface color are white edged with black making a laced effect. The main tail feathers are black. The wing bow and back of the male are white.

Golden.—Applied to a variety of Wyandotte similar to the Silver except that a golden color replaces the white or silver color.

¹ English Guide to the Breeds. The Student is also referred to the American Standard of Perfection.

Black.—A solid black in all surface color.

Mottled.—The surface color is speckled, usually black and white, the black predominating.

Light.—Applied to a variety of Brahma which has similar markings as the Columbian variety.

Brown.—Applied to a variety of Leghorn. Male: Neck hackle, saddle feathers black edged with red. Primary and secondary wing feathers black with lower edge of lower web red. Undercolor slate. Female: Neck similar to the male. Tail mostly black and surface color brown, finely striped with a darker brown.

Red Pyle.—The front of neck, shoulders, wing coverts and fronts, tail, coverts, and body of the male are white. The back and wing bows are red. Neck hackle light orange. The neck, wings, back, tail and body of female is white. The neck feathers may be tinged with gold. Breast of female is salmon.

Blue.—Neck hackle of female and neck hackle, back, wing bow, saddle and tail of the male are dark blue. The balance of the surface color is a slaty-blue.

Speckled.—Applied to a variety of Sussex in which the plumage for the most part is a mahogany red, the feathers being tipped with a barring of black and a tip bar of white.

Red.—The surface color for the most part is a cherry red.

Spangled.—The feathers are tipped with black. The balance of the feathers may be white or golden.

Silver Gray.—Applied to a variety of Dorking. The neck hackle, back and saddle feathers of the male are a silvery white. The breast, body, tail and wing bow of the male are black. The neck hackle of the female is black edged with silvery white. The balance of the surface color is gray with silvery white lines, or stipple.

Dark.—Applied to a variety of Cornish. Male: Hackle, wing fronts and bars, tail, breast and body black. A mixture of red and black in back and saddle. Female: neck similar to male. Balance of surface mahogany with two or three black lines conforming to the shape of the feather.

HISTORY OF THE BREEDS

THE AMERICAN CLASS

The American class includes the following breeds: Plymouth Rocks, Wyandottes, Rhode Island Reds, Javas, Dominiques, and Buckeyes.

The American breeds are noted for their adaptedness as general utility fowls. They are of good size, furnishing a



FIG. 6.—Barred Plymouth Rock hen. A representative of the American class and good utility stock. One of the best breeds for the farm.

goodly amount of meat, and are good egg producers. They are rather quiet in disposition and are adapted to the farm.

The American breeds have their origin in America.

The Plymouth Rocks.—There are six standard varieties—namely: Barred, White, Buff, Partridge, Silver Penciled, and Columbian.

The Barred Plymouth Rock is the most popular fowl in America and had its origin in the New England States.

The first product was produced by crossing the Asiatic fowls and Dorking. This was about 1850. It is quite possible that the Black Java entered into its makeup.

This breed is perhaps the best utility bird of the American class; the skin and legs are yellow and the body of good size, thus meeting the market demands. They develop to a good size and produce a goodly number of eggs. The hens make good sitters and mothers.



FIG. 7.—Barred Plymouth Rock cock.

The Barred Plymouth Rock, as developed in feather pattern at the present time, is a beautiful bird. He has earned his berth in the hearts of all Americans and is named after the Plymouth Rock, the memory of which was held so dear by our forefathers.

Mr. Frost, of Maine, produced the white Plymouth Rock in 1875 and claimed they were "sports" from his barred breed.

Mr. I. K. Felch says: "The Barred and the White are the

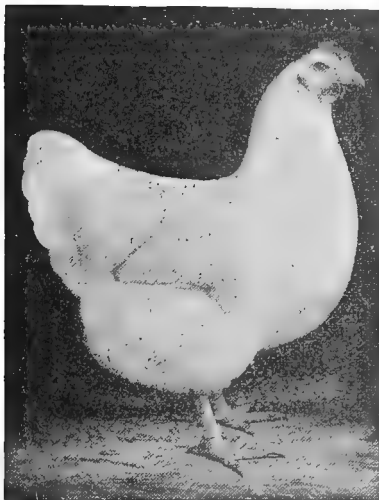

FIG. 8.—White Plymouth Rock hen.

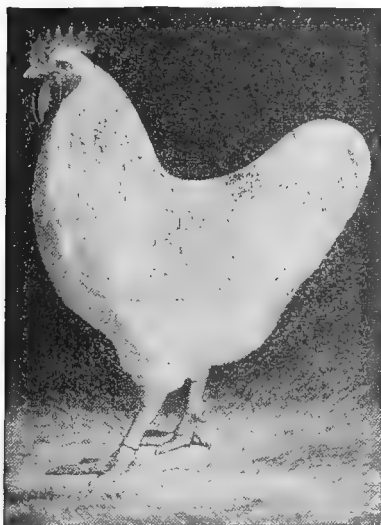

FIG. 9.—White Plymouth Rock cock.

only Plymouth Rocks of absolute purity of Plymouth Rock blood."

The foundation of the Partridge Plymouth Rock is the Partridge Cochin and the Silver Penciled Plymouth Rock and is founded on the Dark Brahma.

The Buff Plymouth Rocks are a conglomeration. The first ancestors were bred by Mr. Wilson, of Massachusetts, who crossed the Buff Cochin on the Light Brahma, and Mr.



FIG. 10.—A pen of Silver Wyandottes.

Aldrich who crossed the White Plymouth Rock on the Rhode Island Reds. The progeny of the union of these different strains constitute the ancestors of our present Buff Plymouth Rocks.

The standard requires the following weights of Plymouth Rocks: Cocks, 9.5 pounds; cockerels, 8 pounds; hens, 7.5 pounds; pullets, 6 pounds.

The Wyandottes.—There are eight standard varieties of this breed, as follows: Silver, White, Buff, Partridge, Silver Penciled, Black, Golden, and Columbian.

The Silver Wyandotte is an American product, and is supposed to have originated from a cross of a Light Brahma on a Silver Hamburg, though the exact cross making up the ancestors of this very useful breed is wrapped in obscurity. The Silver Wyandotte was the first variety perfected and the first to be admitted to the standard.

They are quiet, lovable, excellent layers, good sitters and mothers. They make an excellent table fowl, as the chicks



FIG. 11.—A Silver Wyandotte pullet.

feather early, grow rapidly, and on proper feed are plump at seven or eight weeks old and ready for the table.

The second variety to be developed was the Golden, which Mr. McKeen, of Wisconsin, produced by crossing the Rose Comb Brown Leghorn on the Pea Comb Partridge Cochin and Buff-colored females. This progeny was crossed with Buff Cochins and Golden Sebrights.

In the Golden Wyandotte a golden bay is substituted for

the white of the silver, otherwise they are the same in conformation and feather pattern.

The Wyandottes lay a small egg because there is Silver Spangled Hamburg blood in the original Silver Wyandotte.

The ancestors of the present White Wyandotte were "sports" from the other varieties. The standard requires plumage of a chalky white throughout.

It is difficult to determine just what crosses produced the Buff Wyandotte. Various crosses, some of which contribute



FIG. 12.—A Silver Wyandotte hen.

to the present variety, were made. These were Silver Wyandotte on Rhode Island Reds, Golden and White Wyandottes on Buff Cochins, Golden Wyandottes on Buff Cochins, Buff Cochins on Golden Spangled Hamburgs, Golden Wyandottes bred to White and Golden crosses.

In all buffs the surface color must be even—there should be a rich buff under-color extending to the skin. The feathers

must be free from shafting or mealy appearance. White and black in the wing feathers is considered a serious defect.

Buff birds have a tendency to fade with age, thus a good breeder may not be a good show bird so far as plumage goes.

The Partridge Wyandotte appears to be a mixture of Golden Penciled Hamburg, Golden Wyandotte, and Partridge Cochin.



FIG. 13.—Buff Wyandotte pullet.

The Silver Penciled Wyandotte is a mixture of Dark Brahma, Partridge Wyandotte, and Silver Penciled Hamburg.

The Black Wyandotte, according to Mr. Clements, is a "sport" from the Silver Wyandotte.

The Columbian Wyandotte was probably the progeny of crosses between the Light Brahma and the White Wyandotte.

The Columbian Wyandotte is one of the most popular of this breed.

The standard requires Wyandotte cocks to weigh 8.5 pounds; cockerels, 7.5 pounds; hens, 6.5 pounds; pullets, 5.5 pounds.

The Rhode Island Reds.—It would be a rather difficult task to determine just what breeds contributed to the production of the Rhode Island Reds, but it appears that fanciers and



FIG. 14.—A single comb Rhode Island Red Cockerel. Note length of body. This is another good breed for the farm, being good egg producers and possessing flesh of good quality.

farmers in Rhode Island selected red male birds as far back as 1850 which were bred on common hens. These origins apparently involve a mixture of Cochin China. The state of Rhode Island appears to be their birthplace, and in that state there was bred, according to Mr. Taylor, imported birds, the cock of which was a peculiar red or yellowish Dominique and

the hens a bay or reddish bay, and that the progeny of these crosses varied in color. A little later the Malays were introduced and it is not beyond a possibility that these entered into their makeup. About fifty years ago, in Little Compton, Rhode Island, Red Cochin China cocks and Red Malay cocks were selected and crossed on these flocks. Later Brown Leghorns were introduced into Compton territory, but whether



FIG. 15.—A single comb Rhode Island Red pullet. Note the length and depth of body.

these entered into the makeup of the Reds appears to be uncertain.

The Rhode Island Reds are said to be an out-cross and have been criticised by many, but the fact remains that they are very popular in America, make a good utility bird, lay a goodly number of eggs, and their meat is of excellent flavor.

The color of the Reds must be uniform, as a lack of uniformity

positively disqualifies them. The undercolor should be a rich red. The feathers must be free from shafting.

The Red has a long, broad back, full breast, and long keel and is thus qualified as a general-purpose fowl.

Of the Reds there is the Single Comb and the Rose Comb.

The standard requires the cock to weigh 8.5 pounds; cockerel, 7.5 pounds; hen, 6.5 pounds; pullets, 5 pounds.

The Javas.—The Javas are of two varieties—namely, the Mottled and the Black.

Their origin appears to be wrapped in obscurity, but seems to have originated in that cradle of development of American breeds, the New England States. From the Black Java “sports” were derived from which the Whites originate.

The standard weight requirements are for cocks, 9.5 pounds; cockerels, 8 pounds; hens, 7.5 pounds; pullets, 6.5 pounds.

The Dominiques.—This, another American production, was first produced in the New England States and in many respects resembled the Barred Plymouth Rock, but by careful selection and breeding their semblance is gradually getting farther apart. They are provided with a rose comb, whereas the Plymouth Rock develops a single comb. It has never become popular as has the Barred Plymouth Rock.

Of the Dominiques there is one variety which by some has been supposed to have something to do with the ancestry of the original Barred Plymouth Rocks.

The standard requires the cock to weigh 7 pounds; cockerel, 6 pounds; hen, 5 pounds; pullet, 4 pounds.

The Buckeyes.—This is another American breed whose ancestry appears to be wrapped in obscurity. The breed has never become popular. In body they have some semblance to the Rhode Island Reds. The general plumage color is a mahogany bay.

The standard requires the cock to weigh 9 pounds; cockerel, 8 pounds; hen, 6 pounds; pullet, 5 pounds.

The Buckeyes have a pea comb.

THE ASIATIC CLASS

The class of Asiatics includes the following breeds: Brahas, Cochins, and the Langshans.

The Asiatic breeds are noted for their large size. They are particularly valuable in capon production, developing to large size and are of good quality of meat. The Light Brahas are most used for this purpose.

For standard characteristics of all breeds one should refer to the American Standard of Perfection.

The Asiatics have their origin in Asia.

The Brahas.—There are two varieties of Brahas—namely, the Light and the Dark.



FIG. 16.—A Light Brahma cock.



ALWILDA—SOME PULLET
W. A. HENDRICKSON—MILTON, MASS.]

FIG. 17.—A Light Brahma pullet.

It appears that the ancestors of the Brahas were brought to America from China, and by breeding and careful selection the Brahas of to-day have been developed.

When first imported into this country on a ship—the “East Indiaman”—they were first known as the short-legged Chittagongs, later Brahma Pootra, and later dropping the last half of the name, calling them just Brahma, finally, the development of the two varieties, the Light and the Dark.

The breed was introduced into America about 1847, and in 1866 the varieties, Dark Brahma and Light Brahma, were recognized.

The Dark Brahma was the product of a cross between a Gray Chittagong male and Marsh, or Gray Shanghai or Gray Cochin. This product was sent to Mr. Bailey, of London, England, by Mr. Burnham, of Massachusetts, in 1854, and



FIG. 18.—A Light Brahma hen. This breed is used to a great extent in capon and soft broiler production.

by crosses on the Pea Comb Brahmas the present Dark Brahma was developed.

The Brahmas are used in some parts of the country in the production of soft roasters.

They are credited with laying a fair quantity of eggs, and

laying well in the colder months when the price of eggs is highest.

Care must be taken not to overfeed this heavy breed, as the hens are apt to become too fat and cease to lay. The Asiatics are of a rather lymphatic type of temperament and are not active like the Mediterranean breeds, as the Leghorns.

The Brahmas, particularly the light variety, are used extensively in broiler production.

The American Standard of Perfection requires the Light Brahma cock to weigh 12 pounds; cockerel, 10 pounds; hen, 9.5 pounds; pullet, 7 pounds.

The Cochins.—The standard recognizes four varieties, as follows: Buff, Partridge, Black, and White.

The Cochins originated in China, the first birds being imported into England in 1843.

America and England apparently each have their own type of Cochin, differing both in form and feathering.

While the English call for long legs, long stiff vulture hocks, and flat high carriage breast; the American Standard calls for short legs, full soft fluff and hock, full round breast, and a forward carriage.

The Cochins in their native land, China, vary in color and shades, thus there may be found round red or cinnamon, buff, brown, partridge, pale buff, white, and black.

The buff variety is perhaps the more popular.

The standard weight of the Black Cochin cock is 10.5 pounds; cockerel, 9 pounds; hen, 8.5 pounds; pullet, 7 pounds.

The Buff, Partridge, and White Cochin cock must weigh 11 pounds; cockerel, 9 pounds; hen, 8.5 pounds; pullet, 7 pounds.

The Cochins are provided with feathered legs. Like other Asiatic breeds they are quiet and stand confinement well. They produce a goodly number of eggs and are reported as good winter layers. They are slow in developing, hence they are not best adapted to squab-broiler raising.

Their body is well feathered with fluffy plumage, thus providing them with one essential point for good sitters and mothers.

The Langshans.—There are two standard varieties of Langshans—namely, Black and White.

The Black Langshan was introduced into England from China about 1870. Following 1880 the breed was imported into America from England.

The Langshans have long feathered legs. They present a rather erect appearance and are of good weight. The cock must weigh 10 pounds; cockerel, 8 pounds; hen, 7 pounds; pullet, 6 pounds.

The Langshans, while of good size, may be considered as a utility fowl.

They are good egg producers and develop into good roasters. The White Langshans are said to be "sports" from the Black.

THE MEDITERRANEAN CLASS

The Mediterraneans had their origin in the countries bordering on the Mediterranean Sea.

The Mediterranean class includes five breeds, as follows: Leghorns, Minorcas, Spanish, Anconas, and Blue Andalusians.

These breeds while small in size, yet by their activity and production of eggs have become one of the world's best commercial fowls.

The Leghorns.—There are eight varieties of Leghorns, as follows: Single and Rose Comb White, Single and Rose Comb Brown, Single and Rose Comb Buff, Single Comb Black, and the Silver.

By careful selection and breeding the Leghorns constitute a type of non-sitters. They are the most popular of the non-sitters and had their origin in Italy. They have been bred in America for more than fifty years. The original Italian Single Comb White and Brown Leghorns have been modified, thus there is an American development of a Rose Comb White and Brown varieties.

The Leghorns were imported by America from Italy, from which country England later made importations.

As egg producers the Leghorns have no peer. The White Leghorns are sometimes used for the production of squab broilers on account of the fact that they develop quickly and possess a yellow skin and legs, together with their white feathers, makes this procedure profitable. Being small in

size they are not adapted to large broiler raising or for roaster or capon production. The Rose Comb White Leghorn was produced by crossing the Single Comb White Leghorn on the White Hamburg.



FIG. 19.—A Single Comb White Leghorn cock. A representative of the Mediterranean breed and noted for their superior egg production. This breed is used quite extensively in commercial egg production and to some extent for squab-broiler raising, but too small for medium or large broiler production.

The Black Leghorn is an English production, probably produced by a cross between the Brown Leghorn and the Black Minorca, although it may have been a "sport."

England has also introduced two other varieties—namely, the Duckwing and the Pile. The Pile Leghorn was produced by a cross between the Brown Leghorn and White Leghorn.

The color of the Duckwing Leghorn closely resembles that of the Duckwing Games.

Standard weights for the Leghorns are as follows: Cock, $5\frac{1}{2}$ pounds; cockerel, $4\frac{1}{2}$ pounds; hen, 4 pounds; pullet, $3\frac{1}{2}$ pounds.



FIG. 20.—A White Leghorn of the laying type. (Pennsylvania Department of Agriculture.)

The Minorcas.—The Minorca of to-day is an English product, and were originally called the Red-faced Spanish. It is apparent that their ancestors were imported from the East. The Minorcas find the White-faced Black Spanish as a basis of their ancestry.

The Minorcas are of four standard varieties, as follows: Single and Rose Comb White, Single and Rose Comb Black.

According to Mr. Northup, the Rose Comb Black Minorca is a "sport" from the Single Comb Black and the White Minorca is probably a "sport" from the Black.

The Minorcas lay large white eggs and are very prolific layers.

The standard requires that the cock weigh 9 pounds; cockerel, 7.5 pounds; hen, 7.5 pounds; pullet, 6.5 pounds.

The Spanish.—The White-faced Black Spanish is the oldest

of the so-called Spanish breeds. It is characterized by a white pendulous face and a rich glossy black plumage. The Spanish were imported from the East through the Mediterranean Sea.

The Spanish are great layers. The egg is white and of good size.

The standard requires the cock to weigh 8 pounds; cockerel, 6.5 pounds; hen, 6.5 pounds; pullet, 5.5 pounds.

The **Anconas** were produced in England, and have as a part of their ancestry the blood of the Black Spanish.

There are two varieties of Anconas—namely, Single Comb and Rose Comb.

They are non-sitters, and good layers.

The standard weights for the Anconas are: For the cock, 5½ pounds; cockerel, 4½ pounds; hen, 4½ pounds; pullet, 3½ pounds.

The Blue Andalusians.—The Blue Andalusian is a direct descendant from the White-faced Black Spanish. This breed has its origin in England.

This bird has been accused of wearing the American National colors, as its face is red, its ear-lobes white, and its plumage blue—red, white, and blue.

The Andalusian is difficult to breed true to color, as they readily revert to the color of some of their ancestors, throwing black and white feathers. The Andalusians are good egg producers.

The standard weights for the Blue Andalusians are: For the cock, 6 pounds; cockerel, 5 pounds; hen, 5 pounds; pullet, 4 pounds.

THE ENGLISH CLASS

The English class was apparently brought to light in England.

The English have done much in the development of the breeds of poultry. Next to America they are great lovers of birds and of beautiful feather patterns.

The Dorkings.—There are three standard varieties of this breed—namely, White, Silver Gray, and Colored.

The Dorking is one of the oldest breeds of fowl. Its real

origin is wrapped in obscurity, but it is possible that this breed is one of those referred to by the Romans in their early writings. The Dorkings are a short-legged, five-toed fowl.

The standard requires the White Dorking cock to weigh 7.5 pounds; cockerel, 6.5 pounds; hen, 6 pounds; pullet, 5 pounds.

The Silver Gray Dorking cock must weigh 8 pounds; cockerel, 7 pounds; hen, 6.5 pounds; pullet, 5.5 pounds.

In addition to these two standard varieties there is a colored Dorking, which is required by the standard to weigh more than



FIG. 21.—Silver Gray Dorking hen. (Pennsylvania Department of Agriculture.)

the above two. The cock must weigh 8 pounds; cockerel, 8 pounds; hen, 7 pounds; pullet, 6 pounds.

The Orpingtons.—There are three varieties of this breed—Single Comb Buff, Single Comb White, and Single Comb Black. The Orpingtons were originated by Mr. Cook, of England.

The Single Comb Black Orpington was the first variety, which appeared about 1886. This was from the careful breeding of the black “sports” of the Barred Plymouth Rocks

bred to Black Minorcas and pullets from this cross mated to Black Langshan males.

Black "sports" from Barred Plymouth Rocks bred to Black Minorcas, and the pullets from this mating bred to a Rose Comb Black Langshan (a "sport") produced the Rose Comb Black Orpington.

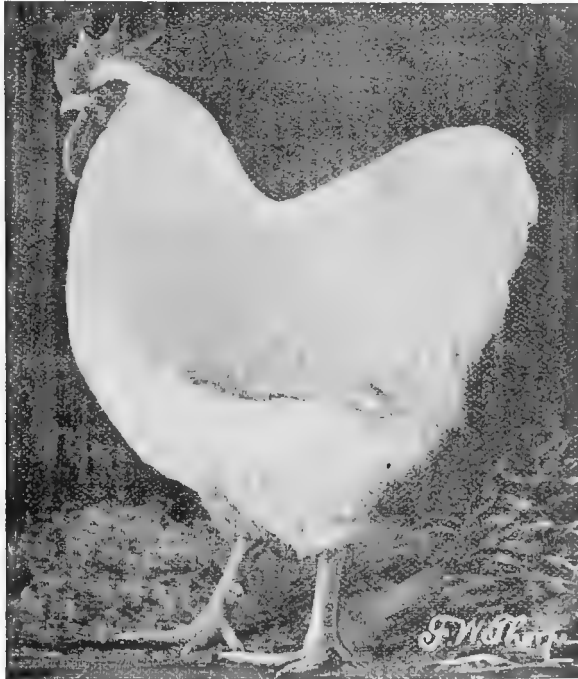

FIG. 22.—White Orpington Cockerel. First prize and champion male at the great Pittsburgh show, January, 1915. Second prize at New York Madison Square Garden, February, 1915. (Bred and owned by J. J. Cooley, Dormont, Pittsburgh, Pa.)

The Single Comb Buff Orpington was also originated by Mr. Cook. These were produced by mating colored Dorking pullets to Golden Spangled Hamburg males, and pullets of this mating were bred to male Buff Cochins.

By mating a White Leghorn cock to Black Hamburg females

and these pullets mated to a male White Dorking produced the Single Comb White Orpington.

The standard requires the cock to weigh 10 pounds; cockerel, 8.5 pounds; hen, 8 pounds; pullet, 7 pounds.



FIG. 23.—White Orpington pair.

The Redcaps.—This is one of the oldest English breeds. They are non-sitters. They are good egg producers. The Redcaps have a distinctive massive rose comb.

The standard requires the cock to weigh 7.5 pounds; cockerel, 6 pounds; hen, 6 pounds; pullet, 5 pounds.

The Sussex.—This is an old, distinct, and excellent breed of English origin, and has just been admitted to the American Standard of Perfection.

There are two varieties—namely, Speckled and Red.

The standard weights for the Sussex are: For the cock, 9 pounds; cockerel, $7\frac{1}{2}$ pounds; hen, 7 pounds; pullet, 6 pounds.

The Cornish.—There are three varieties of the Cornish breed—namely, Dark, White, and White Laced Red.

The Cornish fowl originated in Cornwall, England, from which its name is derived. They were produced by crossing a Black Breasted Red Game on a Red Aseel imported from India. Later there was

introduced into this cross blood of the Sumatra Game.

The Cornish is characterized by having short, thick legs, large thighs, and a deep, broad breast. They are broad across the shoulders and have a rather short, thick neck. They like other games have a rather erect carriage.

The Cornish have an excellent flavored flesh.

The Cornish have been bred for meat alone. They are



FIG. 24.—Dark Cornish cock, three years old.
Weight, $13\frac{1}{2}$ pounds.

usually poor layers. A meat fowl has short legs with large breast.

The standard requires the Dark and White Cornish cocks to weigh 9 pounds; cockerels, 8 pounds; hens, 7 pounds; pullets, 6 pounds.

The White Laced Red Cornish standard weight is as follows: for cock, 8 pounds; cockerel, 7 pounds; hen, 5 pounds; pullet, 5 pounds.

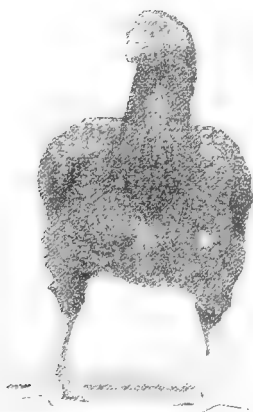

FIG. 25.—Dark Cornish hen "Helen." Supposed to be the best dark Cornish hen in the country to-day. First hen, Madison Square Garden, February, 1915. Weight at two years, $9\frac{1}{2}$ pounds. Note breast. Owned by Ward.

THE POLISH CLASS

The class of Polish include just one breed—namely, Polish.

The Polish were formerly called Polands. Their origin is wrapped somewhat in obscurity and they may not have originated in Poland, but the fact remains that history shows that races of fowls with crests and beards existed throughout South Russia in the early day. There are eight varieties belonging to the Polish breed—namely, White Crested Black, Bearded

Silver, Golden and White, Buff Laced, Non-bearded Silver, Golden, and White.

The White Crested Black Polish present a pleasing picture by their black plumage and white crest.

The Polish are of medium size and good egg producers.

Gold and Silver Spangled Polish have also been bred.

Fanciers are inclined to regard the Polish as ornamental, but in this case it may be said they are useful as well as ornamental.

The standard does not apparently place any required weight.

THE HAMBURG CLASS

The Hamburg class includes just one breed, that of the Hamburg. The Hamburg breed has six recognized varieties — namely, Silver Spangled, Golden Spangled, Golden Penciled, Silver Penciled, White, and Black.

The Hamburgs originated in Holland and derived their name from the city of Hamburg. They are one of the oldest bereds and their blood goes to make up many of the best American and other breeds.

While being classed by fanciers as an ornamental fowl, yet they are great egg producers. They are among the smaller breeds. The eggs are white, but rather small.

The standard does not apparently fix the weight.

THE FRENCH CLASS

The French class includes four breeds, as follows: Houdans, Crevecoeurs, La Fleche, and the Faverolle.

These breeds have been conceded to belong to France, so far as their origin is concerned.

The Houdans.—There are two varieties of this breed—namely, Mottled and White.

The Houdan is to the French what the Plymouth Rocks are to America. They are the most popular fowl in France.

There is a possibility that the Houdan originated from a cross between the Polish and the Dorking, however by some this is doubted.

The essential characteristics are a plumage of black and white, a half crest, and five toes on each foot.

They are excellent layers. The standard requires the cock to weigh 7 pounds; cockerel, 6 pounds; hen, 6 pounds; pullet, 5 pounds.

The Crevecœurs.—There is just one variety of this breed—namely, Black.

This is one of the oldest of the French breeds. It has never become very popular in America.

These birds take their name from the city of Crevecœur. The plumage is a solid, rich, glossy black throughout.

The standard requires the cock to weigh 8 pounds; cockerel, 7 pounds; hen, 7 pounds; pullet, 6 pounds.

The Faverolle.—Of this breed there is but one variety, namely: Golden.

The Faverolle was produced in France by a cross between the Dorking and the Houdan.

The standard weights are for the cock 8 pounds; cockerel, 7.5 pounds; hen, 7 pounds; pullet, 5 pounds.

The **La Fleche** present a striking appearance with their solid black plumage and large long massive bodies.

There is just one variety—namely, Black.

The standard requires the cock to weigh 8.5 pounds; cockerel, 7.5 pounds; hen, 7.5 pounds; pullet, 6.5 pounds.

THE CONTINENTAL CLASS

The Continental class has one breed—namely, the Campine.

The Campine is an old breed and, like many others, their early history is wrapped in obscurity. It appears that in Belgium and other European countries they have been bred for many decades. Their change in feather pattern has been an evolutionary one, as the plumage on the birds of the present day is far different from what it was fifty years ago.

The Campines are of the smaller breeds. They are good layers. The eggs are large in size and white in color.

The Campines.—Of this breed there are two varieties—namely, Silver and Golden.

The Campines, and especially the proud Silver Campine,

have grown in great favor during the past few years in America. It is barely possible that the Silver Campine has some Silver Spangled Hamburg blood in it. Their origin, like many others, has never been fully explained.

The standard weights for the Campines are for the cock, 6 pounds; cockerel, 5 pounds; hen, 4 pounds; pullet, 3½ pounds.



FIG. 26.—A pair of Silver Campines; a representative of the Continental class. They are great egg producers and are very beautiful.

GAMES AND BANTAMS CLASS

Games.—The American Standard of Perfection recognizes many games, as follows: Black, White, Birchen, Red Pile, Golden and Silver Duckwing, Brown Red, and Black Breasted Red.

The games are, so far as we know, as old as time. These birds by their pluck and fearlessness to fight were bred to con-

siderable extent by the Greeks and Romans, who enjoyed seeing animals and beasts tear themselves to pieces and writhe in their agonies.

In ancient times cock fighting was as much in vogue among the Greeks and Romans as it is at the present time in Mexico, Cuba, India, and China.

The present game fowl differs considerable from the type of ancient fighting birds. The exhibition game of to-day carries a rather erect posture, with characteristic shape and carriage. The game stands high on its legs, its head is narrow and long, with thin long neck and fiery eyes.

Game Bantams.—The standard recognized the following varieties of game bantams: White, Black, Birchen, Red Pile, Golden and Silver Duckwing, Brown Red and Black Breasted Red.

In shape, color, and carriage these Game Bantams are the same as the large breeds. They have been bred to bantam size, hence are ornamental.

Dwarf fowls have been known since time immemorial.

The standard weight of Game Bantams are for cock, 22 ounces; cockerel, 20 ounces; hen, 20 ounces; pullet, 18 ounces.

The Black Breasted Red Game appears to be the most popular of all the bantams in America.

THE ORIENTAL CLASS

The Oriental class consists of three breeds, as follows: Malays, Sumatras, and Malay Bantams.

The Malays.—This breed has one variety—namely, Black Breasted Red.

The Malay appears to be one of the ancient types of fowl.

The blood of the vigorous Malay is to be found in many of our present breeds.

The standard requires the Malay cock to weigh 9 pounds; cockerel, 7 pounds; hen, 7 pounds; pullet, 5 pounds.

The Sumatras.—This breed has only one variety—namely, the Black.

This breed, possessing many of the characteristics of the heavy game, is an old variety and its history is little under-

stood, but probably came originally from the Orient. It is a fair producer of eggs. The breed is not popular, though once quite numerous.

The Malay Bantams.—Dwarfed Malays or bantams are recognized as among the standard breeds.

The cock weighs 26 ounces; cockerel, 18 ounces; hen, 18 ounces; pullet, 15 ounces.

THE ORNAMENTAL BANTAMS CLASS

Among the recognized ornamental bantams may be found the following breeds: Sebright, Rose Comb, Booted, Brahma, Cochin, Polish, and Japanese.

The Sebright Bantams.— There are two varieties of the Sebright Bantams—namely, Golden and Silver.

Sir John Sebright, of England, originated this breed, and it is said to be one of the most beautiful combinations of feather patterns ever assembled by nature in a fowl.

By in and in breeding, using a small hen resembling a Golden Hamburg, and these crosses later used on a white cockerel, he developed beautiful silvery markings, making a brilliant contrasting array of colors artistically designed by nature.

The standard places the weights at 26 ounces for the cock, 22 ounces for the cockerel, 22 ounces for the hen, and 20 ounces for the pullet. Thirty ounces will disqualify the cock, 26 the cockerel, 26 the hen, and 24 the pullet.

The Rose Comb Bantams.—There are two varieties of the Rose Comb breed—namely, Black and White.

The weights are the same as for the Sebrights.

The Booted Bantam.—There is one variety of this breed, the White, with the same standard weights as for Sebrights.

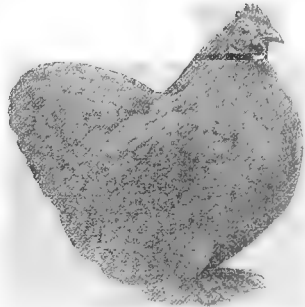

FIG. 27. Black Cochin Bantam hen.



FIG. 28.—Buff Cochin Bantam hen.



FIG. 29.—White Cochin Bantam cock.

The Brahma Bantams.—There are two varieties of this breed, as follows: Dark and Light.

The Light and Dark Brahma bantams have similar markings as the larger type fowl.

The standard weight for the cock is 30 ounces; cockerel, 26 ounces; hen, 26 ounces; pullet, 24 ounces.

The Cochin Bantams.—There are four varieties of this breed—namely, Black, White, Partridge, and Buff.



FIG. 30.—Partridge Cochin Bantam cock.

The Cochin Bantams resemble the larger fowls in shape and color.

The standard weights for these bantams is the same as for the Brahma Bantams.

The Polish Bantams.—This breed has three varieties, as follows: Buff Laced, Bearded White, and Non-bearded.

Their weights are the same as for the Rose Combs.

The Japanese Bantams.—There are four varieties of this breed—namely, Black, White, Gray, and Black Tailed.

The standard weights are the same as for the Rose Combs.

THE MISCELLANEOUS CLASS

The **Sultan** fowl is a native of Turkey.

They have a full crest, muff, and beard, with vulture hocks and profuse shanks and toe feathering. Their coat is white.

The standard does not fix the weight.

The Silkies.—Like the preceding breed there is just one variety, that one is white.

This is a very old variety of fowl and has been described as having "hair like a cat." They have a soft, flossy plumage. Their skin is of a deep pink color. The comb, face, and wattles are of a deep mulberry color. The shanks are of a deep bluish black.

Their name Silkies comes from their silky-like coat.

The standard does not fix the weight.

The Frizzles.—In this breed any color is allowable.

This is a very queer appearing fowl, as the feathers curl backward and upward at the ends.

The colors are those of Black, White, Red, and Bay.

This is one of the breeds of olden times and its origin is unknown.

THE TURKEY CLASS

The turkey class is given one breed, that of turkey.

The Turkeys.—The Turkey breed is divided into seven recognized varieties, as follows: Bronze, Bourbon, Slate, Buff, Black, White, and Narragansett.

The male turkey or tom should be of large frame with a deep body. The breast should be broad, round, and full. The male presents a stately appearance. The head should be of good size and the eyes alert and rather bold expression.

The female turkey or hen should possess a large, deep body with broad, round, full breast. She should be provided with a head of good size with eyes alert and watchful.

The turkey is of American origin, many at this day being wild in some of our forests.

The turkey is the king of the poultry, and is sought as the appropriate bird for Thanksgiving as well as for Christmas.

The most popular variety is the Bronze, which the standard fixes in weight at 36 pounds for the cock, 33 pounds for the yearling cock, 25 pounds for the cockerel, 20 pounds for the hen, and 16 pounds for the pullet.



FIG. 31.—A Bronze Turkey tom. This is the most popular breed of turkeys. A bird raised for the feasts for Thanksgiving and Christmas.

The White Holland Turkey is said to have been originated in Holland. The cock should weigh 26 pounds; cockerel, 18 pounds; hen, 16 pounds; pullet, 12 pounds.

The Narragansett Turkey is a black plumage bird. The cock should weigh 30 pounds; cockerel, 20 pounds; hen, 18 pounds, pullet, 12 pounds.

The Black, Buff, and Slate Turkeys have the same standard weights as the Narragansett.

The Bourbon Red Turkey is a native of Bourbon County, Kentucky, and are bred up to the conception of the Wild Yellow Turkey.

The standard calls for 30 pounds weight for the cock, 22 pounds for the cockerel, 18 pounds for the hen, and 14 pounds for the pullet.

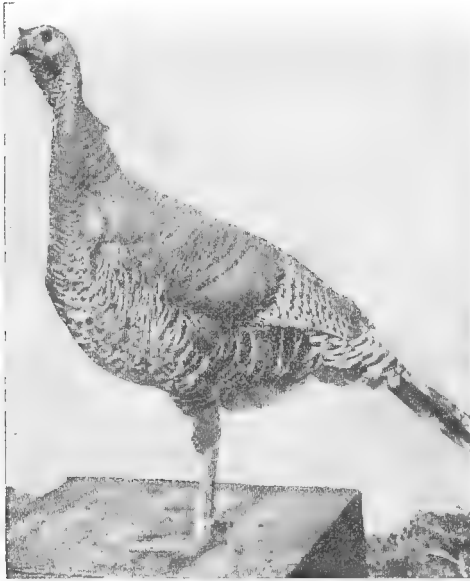

FIG. 32.—A Bronze Turkey hen.

THE DUCK CLASS

There are twelve breeds in the Duck class, as follows: Pekin, Aylesbury, Rouen, Cayuga, Call, East India, Crested, Muscovy, Indian Runner, Swedish, Orpington and Penciled Runner.

Ducks are bred for two purposes—namely, for the production of eggs and the production of meat. The best egg types are not necessarily the best meat types.

The most favorite meat type is the Pekin because of its rapid development and good size, arriving at 6 pounds in weight at eleven weeks of age.

The Indian Runners are developed to a high state of egg production, but on account of their smaller size are not so well adapted for meat production (broiler duck-raising).

The Pekin Duck is a native of China. These ducks have pure white plumage and orange-colored legs, feet, and beak. The standard requires the drake to weigh 8 pounds; young drake, 7 pounds, the duck, 7 pounds; young duck, 6 pounds.

The Aylesbury Duck is a native of England and derives its name from the town of Aylesbury. They have a pale flesh with orange-colored shanks and feet. Their plumage is white. Their weight is similar to the Pekin.

The Rouen Duck is a native of France. It resembles the wild Mallard Duck in color. Its color is a combination of greenish black and brown.

The standard weight is for the drake, 9 pounds; young drake, 8 pounds; duck, 8 pounds; young duck, 7 pounds.

Cayuga Duck is purely of American product, having been originated in New York. It resembles the Ceylon Duck.

The standard weights are the same as the Rouen.

The Call Duck is of a steel-gray color, and in some respects it resembles the Mallard. They are not given any standard weight.

The Black East India Duck is a native of East India. Their plumage is a solid black. They have no standard weight.

The Crested White Duck is a native of Holland. The head is provided with a crest. They are white in color.

The standard weight of the drake is 7 pounds; young drake, 6 pounds; duck, 6 pounds; young duck, 5 pounds.

The Muscovy is a native of Brazil. Of this breed there are two varieties—namely, White and the Colored. The plumage of the Colored is a blue black.

The plumage of the White Muscovy is pure white.

The standard weight of the drake is 10 pounds; young drake, 8 pounds; duck, 7 pounds; young duck, 6 pounds.

The Indian Runner Duck is a native of India. There are three varieties—namely, Fawn, Gray, and Penciled. They are

great egg producers, often laying upward of 300 eggs in a single year.

The standard weight of the runners is for the drake 4.5 pounds, and the duck 4 pounds.

The Blue Swedish Duck is a native of Sweden. Their plumage is blue with white in the breast.

The standard weight of the drake is 8 pounds; young drake, 6.5 pounds; duck, 7 pounds, young duck, 5.5 pounds.

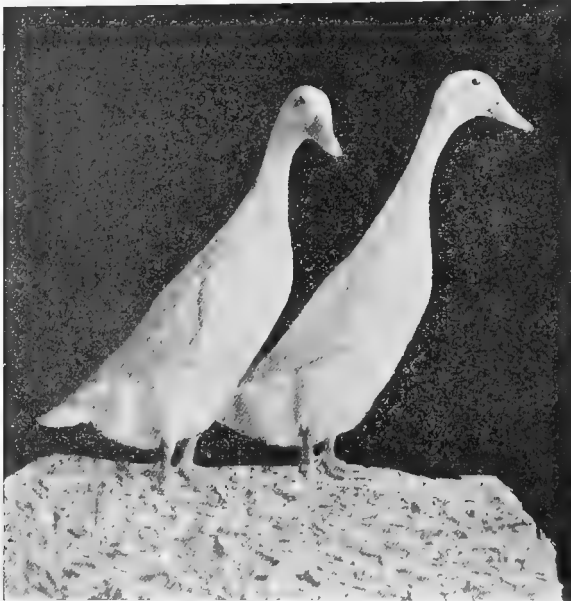

FIG. 33.—Indian Runner Ducks. The Indian Runner is known for its great egg production. Often a single duck will lay close to 300 eggs in a single year. They are light of body, so are not adapted to broiler production.

The Buff Orpington Duck and the Penciled Runner Ducks are recent breeds created and have just been admitted to the standard.

THE GEESE CLASS

The Geese class consists of six breeds, as follows: Toulouse, Chinese, African, Embden, Egyptian, and the Wild or Canadian.

Of the Toulouse there is one variety—namely, the Gray.

The Toulouse is one of the most popular of the breeds of geese. It is a native of France. Its color is gray throughout.

The standard requires the gander to weigh 25 pounds; young gander, 20 pounds; goose, 20 pounds; young goose, 16 pounds.

Of the Chinese Geese there are two varieties—namely, the White and Brown.

The native home of the Chinese Geese is China, from which they derive their name.

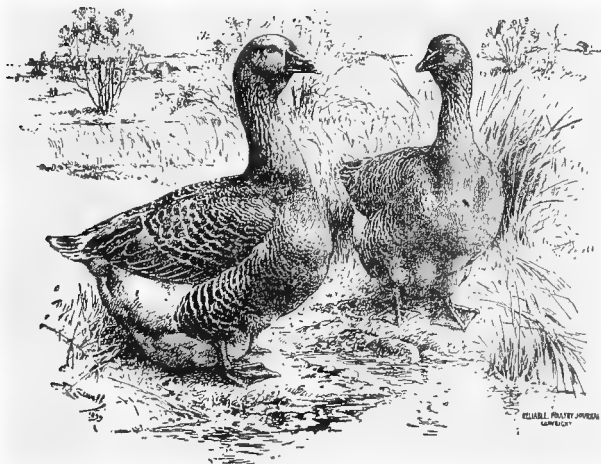

FIG. 34.—Toulouse Geese.

They are good layers and are becoming a very popular fowl. Their weight is not excessive, making one goose about the right size for the average American family, which is not large in number.

The standard requires the Chinese gander to weigh 12 pounds; young gander 10 pounds; goose, 10 pounds; young goose, 8 pounds.

Of the African there is just one variety, that of the Gray.

The African Geese are natives of Asia and Africa. They probably originated in Asia, from which place they are supposed

to have been taken to Africa more than a century ago. Their color is a light gray shading into a darker color as the neck is approached.

The standard requires the gander to weigh 20 pounds; young gander, 16 pounds; goose, 18 pounds; young goose, 14 pounds.

Of the Embden there is one variety, that of the White.

The Embden is a native of Germany, and their name is derived from the name of the town of Embden, which was at one time the center of the goose market of that empire.

The plumage of the Embden is a pure white throughout.

The standard requires the gander to weigh 20 pounds; young gander, 18 pounds; goose, 18 pounds; young goose, 16 pounds.

The Egyptian goose has one variety—that of the Colored. It is a native of Egypt, from which country it takes its name.

The color is gray with black on the upper part of the body.

The under part of the body is a pale buff and yellow penciled with black lines.

The standard requires the gander to weigh 10 pounds; young gander, 8 pounds; goose, 8 pounds; young goose, 6 pounds.

They are the baby of the goose family.

The wild or Canadian Goose is gray in color. The head is black with a white stripe nearly covering the sides of its face. The neck is black, shading into a light gray at the base. The wings and back are dark gray and the tail is black.

The standard requires that the gander weigh 12 pounds; young gander, 10 pounds; goose, 10 pounds; young goose, 8 pounds.

THE CORNELL OUTLINE FOR STUDENT PRACTICE

Each student is requested to handle the 20 fowls in the coops, observing carefully and recording their judgment of the sex, age, weight, and condition of each. Indicate cock by c; hen by h; cockerel by ckl; pullet by plt.

	Band No.	Sex	Age	Weight	Condition	Variety	Remarks
1							
2							
3							
4							
5							
6							
7							
8							
9							
10							
11							
12							
13							
14							
15							
16							
17							
18							
19							
20							

CHAPTER III

THE PROBLEMS IN MATING AND IN EGG PRODUCTION

IN poultry breeding the foundation of success is the correct mating of the breeding pens.

The cock should possess the characteristics of his breed and variety and an abundance of vitality. His crow should be strong and clear, his movements active, his attention to the hens marked, his comb and wattles ruddy, which indicates health. He should not show any effeminacy, not look like a hen with sickle feathers, but show masculine all over.

The breeding hens should show the characteristics of their sex, a refinement of head and body lacking in the cock. They should not suggest hen-feathered cocks, but look feminine all over. They should be active, industrious in scratching and foraging, and sing considerable, showing health, vigor, and happiness.

As perfect breeders cannot be expected, some provision must be made to correct excesses and deficiencies. This is done by exposing an excess in one sex to deficiency in the opposite sex. If a cock is too long legged, correct this excess of length by mating to hens that are short legged. The resulting progeny will consist of chickens, some of which, like the cock, are too long legged, some like the hen are too short legged, and some with the uniting characteristics of the sexes are correct in the length of leg. The last are the ones which it was desired to produce, and while in subsequent breeding these will show reversion to both the long-legged and short-legged ancestors, according to Mendel's law, one-half of their progeny will be like the parents, with legs of medium length. This rule will hold good of all excesses and deficiencies, except as it may be modified by prepotency, reversion, and sudden variations in either sex. By *prepotency* is meant the power

that enables the male to beget progeny like himself, irrespective of the characteristics of the females he may be mated with, or a female to produce progeny like herself, regardless of the properties of the male with which she is mated. The female may be equally prepotent with the male.

Birds for the breeding pens should have the right kind of ancestry, for unless they have been bred true to standard for many generations and their various desirable points thoroughly fixed reversion to undesirable points are more likely to occur. In this instance, if reversion takes place, it is more likely to be of the desirable qualities, and if variations take place it is more likely to be a favorable variation.

Qualities, good or bad, can be intensified by mating together fowls possessing such qualities. If one desires to produce good length of body he should mate together both males and females with good length of bodies. In this instance not only will the quality be likely to be inherited, but inherited in an increased and intensified degree. If fowls closely related in blood have some constitutional weakness and are mated together, it is reasonable to suppose that such weakness will be inherited in an intensified form and that such inbreeding will be disastrous; if both fowls are vigorous and healthy, even though nearly related in blood, there is no reason to believe that their progeny will be constitutionally weak. The greatest factor in inbreeding is the intensifying of the qualities common to both parents, either good or bad, which if bad produces an impairment of vigor and a decline in health. Two-year-old hens are preferable to pullets, they lay a larger egg, hatch a larger chick, and the chicks develop into larger fowls. If pullets are used they must be full grown. The first batch of eggs a pullet lays should never under any consideration be set. Cockerels should be mated with hens and not pullets.

Pullets should be mated with cocks and not cockerels. The number of females to be mated with one male depends upon the breed, age, and activity of the male. This is, in part, determined by observation.

In mating see that the birds conform to the American Standard of Perfection in shape, height, length of body, neck,

length of back and breast, and length of legs. The eyes must be of proper color and the comb of proper size and shape. They must stand squarely on the legs and the legs wide apart. The plumage should be of proper shade or color. The birds in one pen should all be of the same type and color. See that the tails are carried at the right angle. Do not have quarrelsome hens in the pen. Such a hen should not be used for breeding purposes, or if her good qualities overshadow this defect then it is better to mate her alone.

The **color problem** is one of the difficult items in breeding. The three primary colors in the poultry-breeders spectrum are white, black, and red; and when a breeder understands the relative values of these to one another he has mastered the first principle of color breeding, and can, with practice, produce almost any desired shade of color in the plumage of the fowl. Physical science teaches us that black is not, strictly speaking, a color, but that the word is applied to the absence of all color; also that white is not a color, but is the result of a combination of seven primary colors; for the poultry breeder it is convenient to consider both black and white as actual colors, and to place them alongside of red. Working with these three as primary colors, the breeder has produced the many beautiful shades and markings which characterize our numerous varieties of domestic fowl.

Red is the most persistent of the three colors. Accepting the view that all domestic fowls are descended from the common ancestor, *Gallus Bankiva*, it is not surprising that this should be so, for in the male of this wild ancestor of our domestic races red is the predominating color and completely overshadows black, the only other color in his plumage. Thus we get at the reason why red should be the most permanent of all colors in the plumage of fowls, and we also see why black should be more permanent than other hues, it being the color of secondary importance in the wild ancestor.

White plumage is probably produced in one of three ways: There can be but little doubt that the true source of white as a fowl color is albinism, and the proof of this is that fowls coming as "sports" or albinos from parents which are black, or of some other color, are much more permanent in shade

of their plumage than white fowls which are produced by crossing or selection. Albinos almost invariably reproduce themselves in the progeny and seldom revert to the colors of the parents from which they came; white fowls produced in other ways have a decided tendency to reversion.

White plumage fowls may be produced by selecting specimens of a breed which show the most white in their plumage, and by continuous mating along these lines finally produce some pure white. The third way of producing white plumage fowl is by crossing with a white fowl of different breeds which,

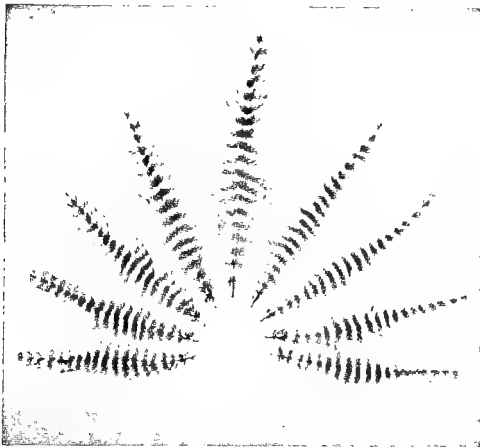

FIG. 35.—Feathers from Hackle of Prince Ringy III (Barred Plymouth Rock). This is wonderful neck barring. (Holterman.)

in appearance, does not differ greatly from the variety which it is the desire to produce.

It has been seen that the male ancestor of the domestic fowl possessed considerable black in his plumage, and it may be surmised that the black plumage varieties were originally produced by selection of the darkest red and black of certain varieties through their evolutionary stages. The present method of producing black is by introducing a cross of a black variety, care being taken to select one which it is desired to produce.

When white and black fowls are crossed the general tendency is the production of white fowls, yet by careful selection other colors may be produced. The Barred Plymouth Rock is one of these examples; another is the Mottled Ancona, also the Houdan.

Red fowls crossed with fowls of other colors will invariably produce progeny having more or less red in their plumage,



FIG. 36.—Feathers from a Barred Plymouth Rock cockbird and two hens, showing a perfect cockerel mating in color.

though the exact shade may be variable, and may be lighter or darker than the red in the plumage of the parent, or a shade may be produced that cannot be called red, but which is closely allied to that color. When red and white birds are crossed the shades produced are straw, lemon, cinnamon, and orange. There will also be noted in breeding this progeny that there is a tendency to revert to the original red, thus red mixed with white producing some shade of color in between.

When red fowls are crossed on blacks, black-breasted red males are usually produced.

White-breasted red cocks are known as "piles" and are produced by crossing white with black-breasted red. If we cross a White Leghorn with a Brown Leghorn the progeny will be a Pile Leghorn, because the Brown Leghorn cock is really a Black-breasted Red.

THE SELECTION OF BIRDS FOR BREEDING

Select only mature birds for breeders. Do not select birds under standard weight. It is much to be desired to keep the weight up to standard.

In selecting breeders avoid crooked breasts, crooked backs, wry tails. The birds must be free from disease or from any indication of having been affected by disease. Strong constitution and great vigor are essential. These points are indicated by the bright red comb and wattles and by the full prominent bright eyes and general alertness and also by its lustrous plumage. Males should be decidedly masculine and females should not show masculine appearance.

Breeding stock should be selected in December, and the matings should be made three weeks before it is the desire to save eggs from them for sitting.

Card says, "The type of a bird can be changed in three years, but ten years are required to change feather pattern."

Brown says, "The male primarily influences the external characteristics—namely, breed, type, plumage, and action. The female primarily influences size of body, color of skin, and legs, constitution, temperament, and habits.

It has been the observation of many poultrymen that there is a tendency of light dry sandy soils to bleach the legs and also to have an influence on the color of the flesh. McConnel says, "Heavy soils have a tendency to deepen the color of the legs. Heavy clay lands are most suited for egg production, and medium and light soils for the production of broilers." Brown of England recommends that three fowls per acre be kept on farms, using portable houses and the fowls in flocks of 10 to 25. It is necessary to divide the birds into

flocks of 10 to 25. The houses should be widely separated. Too many birds in one lot will damage the crops.

It is well to always reject, as breeders, undersize and stunted birds. Likewise reject all immature birds.

Cochins.—In the selection of the Cochin, Mr. Hanchett says: “size comes more from the female side than the male side. So does type. Color and head points depend more on the male.”

The progeny of any parent up to standard size will deteriorate unless given proper food for the upbuilding of the body bone and muscle, etc.). The parent at time of production of eggs must likewise be in proper condition and receive proper feed.

The male Cochin should have short legs. The body should be short and blocky, the breast must be full and round, the back full and as short as possible. A big full-cushioned back in males is desirable. Look to the hens to assist along this line in production of the proper males. The tail should be carried rather low and should be short. He should lean slightly forward, that is, well down in front with cushion well up.

The male should be of good deep shade, and in the buff the color must be even with rich undercolor. The tail and wings must be of solid desirable color.

The females should be blocky in type and full in feathering. The breast should be deep and rounded, the tail should be short and carried low, the back should be broad and full.

In buffs select females whose feather color corresponds to the color of the breast of the male, provided you have been fortunate enough to secure a proper buff-colored male. The females should be of even color and strong in undercolor. They should be a solid buff in tail and wings. An injury to a new feather just coming in, or one which has been pulled while developing, may cause a white feather to develop in its place. This should not be considered sufficient cause to reject the bird from breeding, as that would not be an inherited factor, but an accident as a result of environment (postnatal).

Bufs fade with age if allowed in the sunlight. White birds tend to sunburn and show brassiness of the wing-bows.

In selecting for breeding, for instance, in whites or blacks, it is well to breed from birds who are known not to show off colors, but that breed true to color. It is well to keep in mind in purchasing birds for standard breeding to secure them from reliable breeders who will furnish birds from the proper ancestry or blood lines. This is desirable to the utmost extreme in those whose color factors have not been firmly established, as in buffs and some others where there seems to be a fight for an equilibrium between black and white. Thus it may be said, in general, using the buff again as an illustration, a too light undercolor is likely to throw white in the progeny unless the bird be of sound ancestry, and too dark in undercolor in birds of dark shade have a tendency to throw black in wings and tails of the progeny.

It is not advisable to select pullets that show white in the undercolor of the neck, or a cockerel that shows red on his wing-bows.

It is to the best interest of the breeder to select those birds that feather fastest and develop quickest and reach the full standard weight.

Brahmas.—In the selection of Brahmas do not select a short-limbed male as a breeder. The males contribute as much to the size of the progeny as do the females. The male must be bright, active, and vigorous.

The male must be strong, ready to banter, and to crow.

Do not select a male that is always looking for a place to sit down. He will be a disappointment. The male should be strong in color.

In the Brahma the chicks are apt to run a shade or two lighter than the male.

A bird strong in color has the best chance in the show room.

The male Brahma must be reasonably tall, large, long bodied, legs and toes well feathered, and strong in color.

In selecting the female Brahma it will be well to keep in mind that small hens mean small progeny. The hens should have good length of body. The hens must be active, alert, on the go, and with fairly long legs. The best female breeders are those that have gone through one adult molt and who have retained their color.

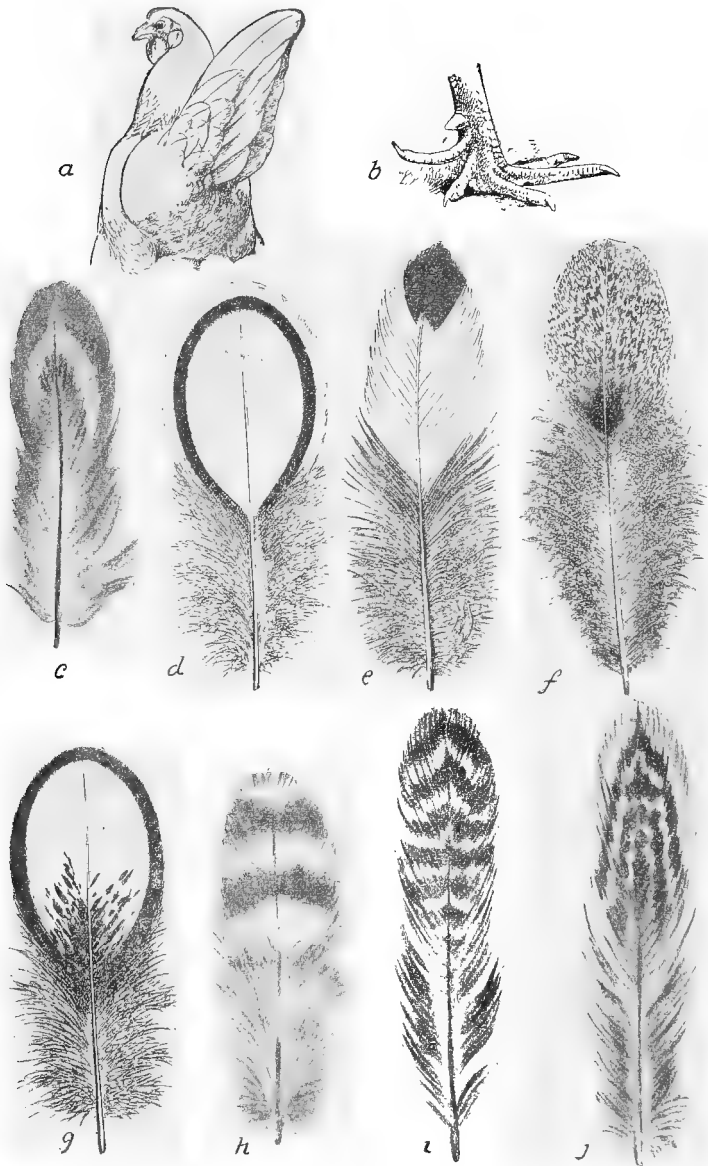

FIG. 37.

See that your birds for breeding have the proper colored eyes. Too often this point is overlooked.

In selecting males of laced varieties for illustration, the Silver Laced Wyandotte do not breed from a male showing white in the back or secondary white edging on the breast or thigh feathers.

Barred Plymouth Rocks.—Proper mating of Barred Plymouth Rocks is of the more difficult problems.

It appears impossible to produce males and females all the same shade of color from any one mating. The males may be lighter than the females. If the females from the mating are of standard color, the males are likely to be too light for exhibition purposes, or if the males are of standard shade of color feather pattern, the females may be too dark.

Therefore, mating of dark birds is essential to produce cockerels of the right color and character of barring, and lighter matings to produce females of proper barring. Female birds showing white undercolor should not be bred from. The barring should extend to the skin.

Owing to the origin of the Barred Plymouth Rocks, the natural tendency is for the females to come darker in color than the males. This is true if you breed just one male and one female together. Double mating then in Barred Plymouth Rocks means *a.* that you must mate a dark colored male bird with dark colored females for one mating; *b.* that you must mate a light colored male with light colored females for the other mating. In other words, to-day there are two kinds of Barred Plymouth Rocks—a light one and a dark one. It may be considered that these are two strains separate and distinct from each other. These two strains should never be crossed on each other. If light male and dark females are bred together or vice-versa the result will be very disappointing. So long as light birds are bred together their progeny will be

FIG. 37.—Plate showing feather patterns: *a.* A wry-tail hen. Do not breed from wry-tailed birds; *b.* showing the fifth toe, which is characteristic of the Dorking; *c.* lacing as required of the Dark Cornish; *d.* a double-laced feather; *e.* a silver spangle; *f.* a stippled feather; *g.* a ticked feather; *h.* a barred feather, as noted in the Barred Plymouth Rocks; *i.* a feather marking characteristic of the Partridge variety, as the Partridge Rocks; *j.* a fully penciled feather.

light, and if dark birds are bred together their progeny will be dark. That is, in this case like begets like, but when you cross the shades the results will be disastrous as you will have neither, but a mixture. Three points are then to be remembered. These are as follows:

There are two varieties of Barred Plymouth Rocks, the dark colored and the light colored.

To breed them right, you must keep them absolutely separate.

You must mate dark colored males to dark colored females and light colored males to light colored females.

In the selection of the Rocks it is essential to pay particular attention to conformation. The Rocks are required to have a long back, deep breast, and a large body.

The male White Plymouth Rock must possess plumage pure white and free from brassiness. He must be strong, vigorous, and active, and his comb should be rather low and he should possess a full hackle.

The back should be rather long and broad with a concave sweep toward the tail. The tail should be fairly well spread, carried rather low, and should be short. The breast should be broad and full. His legs should be yellow in color, wide apart, and he should stand squarely on his feet.

In all matings type is of first importance.

The **Rhode Island Reds** should possess proper length of body, possess an even red, not a buff, and a rich undercolor free from sooty or slatiness.

The greatest difficulty in breeding reds is in color. There are many color factors not yet fixed, though careful selection and breeding has been in progress a long time.

Card says, "the darker or blood-red variety produces birds of almost an exact even shade, very rich and brilliant and red.

Light-colored males are likely to throw buff and even white; on the other hand, very dark males may produce smut in the undercolor or black on the surface. Some breeders maintain it is best to select a male of medium red color. Another serious tendency in male defects is white in undercolor of hackle and saddle. Such a male should not be bred from. The quill of the feather should always be red, not white or

black. The undercolor should be of about the same shade as the surface color.

In mating reds the birds should be of uniform brilliancy—cherry red in both surface and under color. It is maintained by some of the leading breeders that a small amount of smut in either sire or dam is practically essential to obtain the best surface and undercolors for exhibition purposes. The neck hackle, wing bow, and saddle should be a uniform dark brilliant cherry red and the balance of the surface an even uniform rich red color. In mating pluck a feather from the breast of the cock or cockerel and compare it with the back feathers of the hen. To obtain the best results with the mating these colors should blend.

The hen gives type and size to the progeny. The male gives the color. These two points should be kept in mind in mating Reds.

If you do not make proper matings to produce proper color, you lose variety characteristics. If you do not make proper matings to produce the proper shape in the progeny, you are losing the principal breed characteristics.

Wyandottes.—In selecting Wyandottes it is well to keep in mind that the breed characteristics call for a broad, deep, well-rounded breast, with full saddle and hackle, raising with concave sweep to the tail. Breed from cockerels and pullets that are slow in developing tails.

In selecting the male it will be well to keep in mind the fact that a male that is ugly and crabbed to his hens, driving them away from their food, is not likely to make a good breeder.

An old experienced breeder of Partridge Cochins, in discussing the mating of this breed, says, "If you will take a standard female and a male with rich dark standard surface color, but white undercolor, you will get half of the pullets show birds."

Proper attention to undercolor is of the most vital importance in breeding parti-colored fowls.

In selecting breeding birds in the Golden and Silver varieties, see that the lacing is well marked on the thighs.

In mating Silver Penciled Wyandottes for the production of pullets, the cockerel should have some frosting on his breast

which, of course, would debar him from the show ring but will have a tendency to produce the proper colored females, provided all other markings in both sire and dam are correct.

In buffs the birds selected for mating should have proper undercolor. That is, not too light; though too dark may have a tendency to produce too much objectionable black, noticeable particularly in the tail of the progeny; and too light may cause white, particularly in the wing flight feathers. Buff pullets are likely to lose their even buff color as soon as they begin to lay.

To get the proper color markings, proper slaty undercolor is essential in Silver Spangled, as the S. S. Hamburg, and in Columbian varieties, as the Columbian Wyandotte.

Care need be exercised in selecting parti-colored birds for breeding. In the Columbian varieties the black of the hackle, wing, and saddle also of the proper portion of wing and tail should be dark as the tendency of the progeny, especially in the cockerels, is to be lighter than the parents.

In most parti-colored birds, to obtain the best show birds it is necessary to make a mating for the production of exhibition cockerels and another for exhibition pullets.

In Mottled Houdan the male should be rather dark for pullet production, as here white has a tendency to dominancy over black and the pullets have a tendency to be lighter than their parents.

It is impossible to tell just what kind of plumage a bird will have until it has its last coat. Black chicks may have white baby feathers which come in black after these are shed. This is also the case with Reds and many other breeds. The baby feathers do not have that correctness of marking that the same bird will in its mature plumage. We should therefore not be too hasty in discarding our promising youngsters until we have had time to see the adult plumage.

White Leghorns.—In selecting the Single Comb White Leghorn attention should be given to the proper weight. Too often in selecting for the fixing of the laying character and other important items the subject of weight is entirely overlooked. A bird should possess proper weight and not allow of the tendency toward a bantam type. The cockerel should

be of proper proportions, head up, active and alert, ready to banter and to crow. His plumage should be pure white and free from brassiness.

Utility Classification.—Birds are classified as being of egg type, meat type, or dual purpose. Brown's method of determining whether a bird is of any certain one of these



FIG. 38.—A Single Comb White Leghorn hen of laying type. Note the wedge-shaped body as indicated by the lines, also long back and keel, head erect, eyes alert, legs wide apart, of medium size, free from coarseness, and of fine texture. (Rancos.)

types is to draw a perpendicular line transversely through the body of the fowl on a line with the legs. If the greater bulk of the body lies in front of the line the fowl may be classed as among the meat type. If the greater bulk of the body lies behind this imaginary line it is classified as belonging to the egg-producing type. If the bulk on either side the line is equal then it is classed as a dual purpose fowl.

The **fixing and intensifying of the egg-laying characters** is beyond the experimental stage. While the jungle fowl *Ban-kiva* only layed one or two clutches of 12 or 15 eggs each year, the present Leghorn, as well as some carefully selected and bred fowls of other breeds, lay close to 300 eggs a year and close to 1000 eggs in their lifetime. After weight, constitutional vigor, and conformation comes their egg-laying faculties. It is well, in building up an egg-laying strain, to hatch the birds the first week in April, as then by proper care and feed these birds will be mature and begin laying by the time the high price of eggs is on, and will probably not molt till the second fall. Whereas, if hatched earlier, they may commence to lay while eggs are still a low price, and by the time the high prices come the birds go into a molt and cease laying for a while and thus interfere with their egg production at a time when eggs are most desired from a commercial standpoint.

In making the selections one should select for longevity, use carefully selected early producing pullets, use fall and winter layers, select heavy eaters, select early risers and late retirers, and select mature birds. The pubic bones should be wide apart and straight; the bird should possess capacity, that is, at least four finger's-breadth from the posterior point of the sternum or breast-bone to the pelvis; the ischium should be thin, as a thick, meaty ischium means a meat type. The market prefers a white egg and the number ones are required to weigh at least 24 ounces to the dozen eggs. In selecting the hen the skull should not be too broad; the eyes should be prominent; the comb, face, and wattles fine in texture; the eyes snappy and the bird alert; they must stand square on their feet, legs wide apart, front end of body slightly higher than the posterior end; they should be wedge shaped (Fig. 38); the back should be long and a long breast-bone or keel; they should be of happy disposition; the breast should be full; the legs not too coarse and of fine texture and not too long. The body medium size with no coarseness, tail carried rather high. It is noted that the legs should be yellow, but in heavy layers as laying season progresses the legs become bleached out.

The first or earliest cockerels to crow are the most vigorous and make the best breeders.

High egg production is transmitted by both sire and dam.

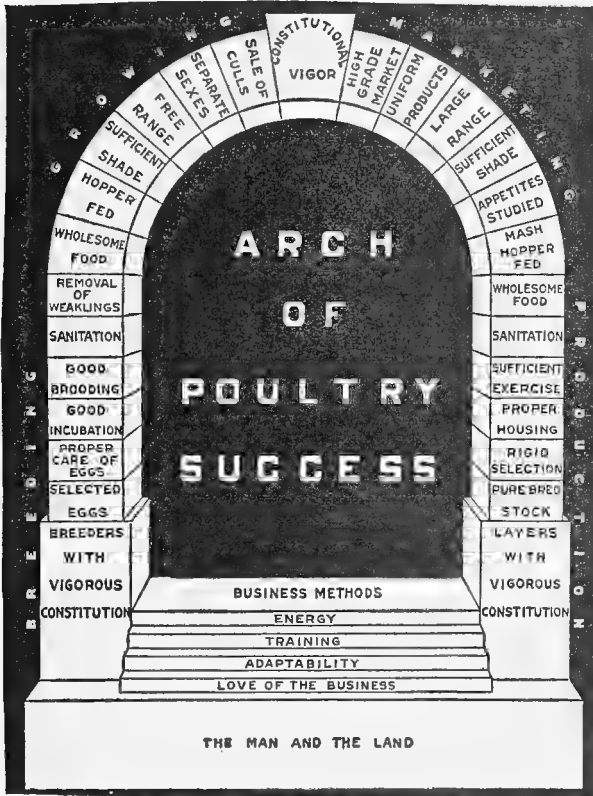

FIG. 39.—Rice's arch of poultry success. It will be noted from this illustration that constitutional vigor is the keystone, the summit and principal stone to the arch of success.

Pullets should be selected at eight weeks of age. Select at this time those with best developed head, eyes, comb, and body. Those well feathered over the back.

The term **rhythm** of egg production is used rather than rate,

in order to emphasize the rhythmical character of egg extrusion. Most hens lay for a period of several days and then skip one or more. The first day of the series the hen lays early in the morning. The time she lays the next day depends largely on the character of her particular rhythm. If the rhythm is such that she lays only every other day, she usually lays about the same time each day—that is, 10, 0, 11, 0, 10, 0, 11. If she lays two days out of three, the first egg is laid during the morning and the second during the afternoon—that is, 10, 3, 0, 10, 2, 0, 9, 1, 5, 0. As the period lengthens, the number laid in the morning increases until the larger proportion are laid before noon, thus: 8, 9, 10, 10, 10, 10, 9, 10, 9, 5, 11, 11, 5, 11, 11, 2, 2, 4, 0. There is however much variation. Pearl found on the basis of winter egg production that his birds fell into three classes, as follows: high, mediocre, and zero producers. The dividing line between the high and mediocre producers came at about 30 eggs. Goodale has confirmed this work. It has been found that broodiness, age, and the time at which laying commences in the fall all influence the number of eggs laid. Various causes interfere with the normal egg rhythm, as environment, season, method of management, and such internal factors as broodiness.

Distribution of Egg Production.—From 52 to 55 per cent. of the eggs are produced during four months—March, April, May, and June. The remaining 45 to 48 per cent. are distributed over the remaining months of the year. The following data illustrate the distribution of egg production. This pen averaged 152 eggs per hen a year, distributing their production as follows: January, 4 per cent.; February, 10 per cent.; March, 14 per cent.; April, 14 per cent.; May, 13 per cent.; June, 10 per cent.; October, 4 per cent.; November, 3 per cent.; December, 3 per cent.

The report of the Storrs laying competition ending in November shows a very unusual distribution of egg production, as heavy in July as in March—the latter month being abnormally low. That competition is therefore not suitable to use in a general average of figures from a small number of cases. For that reason the distribution of production in the preceding Storrs contest is taken, the average egg production in this case being

145 eggs per hen per year. For comparison and tabulation with these carefully kept and accurate records the percentages of general egg production as indicated by the receipts at New York are taken—setting the figures back one month to allow for the time required to get the eggs to market.

To show the annual variations as they occur on a large scale the following table is given. The figures for the months are the percentages of the receipts for the year which arrived in each month.

Year	Jan.	Feb.	Mar.	Apr.	May	June	July	Aug.	Sept.	Oct.	Nov.	Dec.
1911.....	4	6	13	15	19	11	7	8	6	5	3	3
1912.....	3	4	9	16	19	12	9	8	7	5	4	4
1913....	4	6	10	15	16	12	9	8	7	5	4	4
1914.....	4	6	10	15	17	12	8	8	7	6	4	3
1915.....	4	5	12	17	14	11	9	8	7	5	4	4
1916.....	4	5	11	16	16	12	9	8	6	6	4	3
1917.....	3	3	9	17	17	13	9	8	8	6	4	3
Average.	4	5	10	16	17	12	9	8	7	5	4	3

In the average percentages fractions are adjusted to give the percentages in the whole numbers that will express the situation most satisfactorily. Thus a number of small fractions omitted in figures for the reason of heavy production are added to the figure for one or more months of light production where the error is of less effect when the percentages are applied to show the actual egg production month by month.

In the next table the Beltsville and Storrs distributions are given first, then the averages from the first table—adjusting

	Jan.	Feb.	Mar.	Apr.	May	June	July	Aug.	Sept.	Oct.	Nov	Dec.
Beltsville..	4	10	14	14	13	10	10	9	6	4	3	3
Storrs. . .	3	7	12	13	13	12	12	11	7	1	2	4
New York Rec.....	5	10	16	17	12	9	8	7	5	4	3	4
Average...	4	9	14	15	13	10	10	9	6	4	3	3

them to the production situation by setting them back a month—and the average of these three sets of percentages is given as a general average of the percentage distribution of egg production.

In the next table is given the actual egg production month by month when different amounts of yearly production are distributed according to the percentages established.

Lay	Jan.	Feb.	Mar.	Apr.	May	June	July	Aug.	Sept.	Oct.	Nov.	Dec.
72 eggs	3	6	10	11	9	7	7	6	4	3	3	3
100 "	4	9	14	15	13	10	10	9	6	4	3	3
120 "	5	11	16	18	15	12	12	11	7	5	4	4
150 "	6	13	21	23	19	15	15	13	9	6	5	5
180 "	7	16	25	27	23	18	18	16	11	7	6	6
200 "	8	18	28	30	26	20	20	18	12	8	6	6

In the examination of records of pens and flocks making high averages it is found that as a rule production is more evenly distributed through the year than in the general average, and especially that egg production is heavy through the summer and early fall. In no case either in this or in the next competition at Storrs did a pen approximating an average of 200 eggs per hen to as high as 28 and 30 eggs a month. Individual hens may do so; some must when averages for 10 hens go to 25 and 26. In the extremely high averages good laying—far better than usual for the season—is the rule at all times, except the short period in spring when nearly all hens lay well; but where egg production runs at averages of 120 to 150 or 160 per hen per year the result is usually due more to good laying in summer than to good laying in early winter.

RESULTS IN BREEDING FROM UNSELECTED BIRDS

The production of unselected White Leghorns varies widely in different years as influenced by the environment; but from all available records it averages about 130 for the first year, 120 for the second and less than 110 for the third, drops to about 85 in the fourth, and falls about 10 eggs a year after this up to the eighth year. Selected flocks have averaged

160 in America and 190 in Australia. The American record corresponds closely to the average of the upper one-half of the unselected flocks and indicates that the selection has been able to eliminate the lower half.

The first year production of a flock of White Leghorns is no indication of their total production. If the first year is high the second may be low, if the first is low the second may be high; but the total production in three years will in all cases be about the same.

If the first year record of a flock is high, selection of the high layers will materially improve the later production of the flock. If the first record is low there will be little value in selection as even the lowest producer will make a second year record above the general average. The three-year average is in all cases a much more reliable indication of productivity.

The average life of a White Leghorn appears to be about six years. The average production of the fourth year is equal to the average production given for the United States. The average total production is above 500 eggs and the maximum possible production above 1000.

The White Leghorn is the most important egg producing breed at the present time, over one-half of all contest entries being Leghorns. Their average production has been decidedly above the average of the general purpose breeds. Three-fourths of all contest entries have been white.

In the pullet year, as a rule, the bird lays the bulk of the eggs from November to February inclusive. A hen commences to lay later in the second year but in the more favorable time of the year, which is the latter part of February. From this time on she may lay as many eggs in the favorable months as in the first year. She will be slightly slower commencing to lay in her third year but will produce approximately as many eggs as in either of the other two years, possibly laying into the late fall.

Dryden has found that from different matings where the son was bred to the mother, the pullet offspring showed a lower average egg yield than others not inbred. There was greater variability in production from the inbred pullets; that is, there was a wider range between the highest and lowest

individual records than was the case with those not inbred. The vigor of the laying stock as shown by the mortality records was lowest in the inbred stock. The vigor of the offspring as shown by the mortality records of the chicks was lowest in the inbred stock. There was a lower fertility of eggs in the inbred stock.

Sterility of hens is often due to a closure of the anterior or funnel portion of the oviduct, or to an adhesion of the lips of the funnel. In all such cases the sex organs pass through the same changes from non-laying to laying condition as in the birds which actually produce eggs. When the eggs cannot enter the egg canal they are discharged into the body cavity and absorbed. If they enter the duct and the duct be obstructed they may be returned and fall into the body cavity. If the duct is ruptured, the eggs pass along the canal, developing normally till they reach the rupture, then pass into the body cavity. A large number of eggs may be absorbed from the abdominal cavity without causing any inconvenience to the bird. One abdominal cavity examined showed all stages of absorption of such eggs, and a large mass of shell membranes were found in the cavity. The ovary of this bird was the same as the ovary of any laying bird, containing a normal series of developing yolks.

Prepotency is the ability of the parent to fix his characteristics in the offspring.

The male should not only be pure bred, but have the purity of breeding that extends to a high degree of egg laying.

Prepotency does not always follow blood lines. One individual may be prepotent and another of the same blood line or of the same parentage may not. But an individual bred pure to a certain type and other essential characteristics for many generations is more likely to transmit his characteristics than one that is not or is simply a "grade."

The reasons of the above are explained by the Mendelian law.

Some characters segregate, others unite or blend. The eggs produced by a cross bred hen, for example the progeny of a Barred Plymouth Rock and a White Leghorn cross, usually show the influence of both parents. That is, they have neither

the pure white which is characteristic of the Leghorn entity nor pure black and white barred characteristic of the Rock. There is noted a blending of the two factors.

The high egg laying character is transmitted, and it is also necessary that the bird possess excellent vigor. Some sires from high fecundity dams will transmit this character and some will not. It has been definitely shown that there is a progressive increase each year when the parents have been selected among individuals that have production records higher than the average of the flock. This is in keeping with the law of progression. There is sure to be regression or decrease in production unless the breeding stock be selected from among the individuals of high producers. When no selection is practised the tendency is downward.

The Oregon Experiment Station states that by trap-nesting in the pullet year during November, December, and January one can tell the high producers; that those who lay 30 eggs or more during these three months will lay during the year approximately 200 eggs. These should be kept for breeders. Those that lay 10 to 12 or less will prove unprofitable, and those that lay 20 may make a profit. The pullets that lay before six months of age will lay about 200 eggs.

Egg Expectancy.—Philips has given the following as a fair estimate of percentage egg production expectations: Expected egg production by per cents.—White Leghorns.

Month	Pullets	Hens	Month	Pullets	Hens	Month	Pullets	Hens
November....	20	7	December..	15	7	January....	25	15
February.....	32	25	March.....	50	45	April.....	65	60
May.....	62	60	June.....	50	50	July.....	40	40
August.....	30	30	September..	20	15	October....	10	5
No. eggs.....							127.1	108.7

Per cent.

Per cent. broken and cull eggs each month.....	4
These would be sold at half price making the total loss	2
Per cent. mortality, pullets.....	12
Per cent. mortality, hens.....	10

Time of Laying.—In the study of egg production we note that the season of the year and time in the bird's life are factors. Some birds lay in the late fall, winter, and spring; others lay in the spring and early summer. On account of the fact that eggs command the highest price in the fall and winter, we should select for breeders those that lay in the fall and winter. In culling the offspring will probably not produce as high as the culled flock. Hatching quality may be taken as an index to good vitality. The following relative terms have been proposed for degrees of productiveness of birds. (Average opinion of 13 persons.) The figures indicate number of eggs per year.

Phenomenally low.....	32.3
Exceptionally low.....	48.0
Very low.....	62.7
Low.....	84.2
Fair.....	103.8
Medium.....	119.6
Good.....	137.7
High.....	156.9
Very high.....	176.9
Exceptionally high.....	195.4
Phenomenally high.....	213.8

Inheritance and environment influence a hen as to her performance.

The quicker we can determine a hen's productive possibilities the better from a commercial viewpoint. In arriving at this determination we consider her habit of laying, as indicated by the physical examination. This examination should give us what she is or has been doing, precocity and persistency being taken into consideration. It has been shown that the longer we wait to see the quality of production the more accurate we will be.

Birds may lay too heavily the first year and partially break down and not lay so many eggs the second year. Too much forcing may cause a physical breakdown. In a breakdown from forcing, the hen may not be able to fulfill her inherited tendency.

Climate conditions of late fall and winter affect high egg production in that season of the year.

A bird with a physical impediment, as deformed feet, cannot secure ample feed.

In making a physical examination to determine what a bird is doing we must bear in mind that the condition of the comb, vent, pigmentation, and width between the breast bone and pelvis are indications of what the bird is doing or is going to do. The time when a bird commences to lay or ceases to lay is not dependent on the size of the bird. In a heavy laying bird the intestines become larger and longer, and again shrink after her laying period. This lengthening may be as much as 30 to 40 per cent. This same fact holds true of the oviduct. The laying hen is large posteriorly, and when she ceases to lay, the tendency is to become smaller posteriorly. A hen in a non-laying period stores up fat and with it yellow pigment (zanthophyll) which is used when the hen commences to lay. This fat and pigment disappears more rapidly from those parts with best blood supply, and consequently in the following order—vent, eyelids, ear-lobes, lower mandible, base of upper mandible, middle of upper mandible, tip of upper mandible. Of the shanks the fat first disappears from the sides and in front and later at the back; the last to disappear is on the heel just below the hock. Soil and vegetation is a factor in the amount of zanthophyll supplied and will be one governing factor in the amount of pigment stored. Such feeds as tender succulent alfalfa and alsike clover furnish much zanthophyll. Birds have a tendency to bleach out on sandy soil or soil containing much alkali. Wood ashes will cause bleaching.

The greatest fat reservoir or storehouse in the bird is the retroperitoneal region; that is, the lower and lateral walls of the abdomen (Fig. 40, No. 5). When the hen ceases to lay, this storehouse begins to fill with fat covering over the pelvic arch, causing the arch to become blunt. The abdomen now takes on a hard texture. The pelvic arches come closer together and as the intestine and oviduct shorten and become smaller the distance from the breast bone to the pubic bone becomes less.

A hen cannot hold enough reserve material to form an egg a day, so she skips. The power to take in and metabolize food

varies with individuals and is an inherited character. The laying period commences slow, then is intensive, and slows down again near the end, or as the bird passes into her vacation period.

The later in the year a hen lays, the less the chance to pick up large amounts of pigment. For this reason late layers laying over a period of eight to ten months are not so likely to regain high color during their vacation.

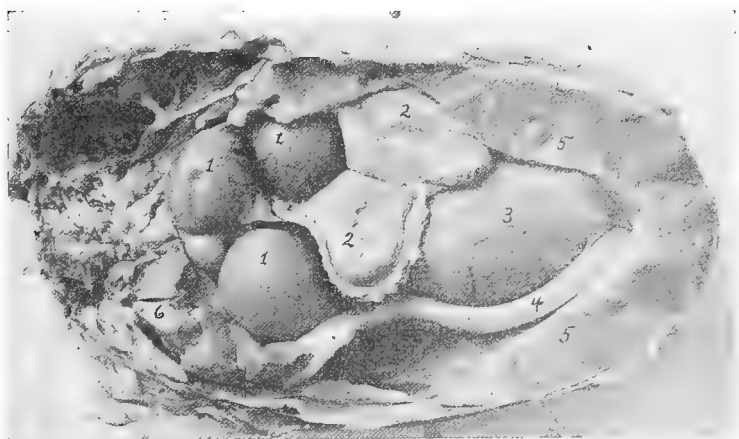

FIG. 40.—Normal functioning reproductive organs of a Single Comb White Leghorn hen. 1, Ova forming yolks; 2, folds of the oviduct; 3, an egg in the shell-gland portion (uterus); 4, rectum; 5, the retroperitoneal fat storehouse; 6, the liver.

Birds may have an inherited tendency to high egg production but by improper feed and no animal feed, as milk or meat meal, will lay poorly and hence molt early, whereas if they had been properly fed and given milk or meat meal or both, they would have laid more eggs and molted later. Therefore in culling care and feed must be taken into consideration. Culling should be done in July and August.

A METHOD OF JUDGING FOWLS FOR EGG PRODUCTION

As Formulated at the Judging School held at Cornell University, Ithaca, N. Y. July 1-6, 1918, and Approved by

the American Association of Instructors and Investigators in Poultry Husbandry.

In order to lay well a bird must have a sound body. As a first consideration a bird must be vigorous and healthy if it is to be able to lay well. Vigor and health are shown by a bright, clear eye, a well-set body, a comparatively active disposition, and a good circulation.

Further, the bird must be free from physical defects such as crooked beak, excessively long toe nails, eyelids that overhang so that the bird cannot see well, scaly leg or anything else that would keep the bird from seeing or getting an abundance of food.

Loss of Fat Due to Laying.—Color or pigmentation changes. These should be observed by daylight. A laying fowl uses up the surplus fat in the body; especially it removes the fat from the skin. In yellow-skinned breeds this loss of fat can readily be seen by the loss of the yellow color. The different parts of the body tends to become white, according to the amount of fat stored in the body and the amount of circulation of blood through that part. The changes occur in the following order:

The vent changes very quickly with egg production so that a white or pink vent on a yellow-skinned bird generally means that the bird is laying, while a yellow-vent means a bird is not laying. It should be recognized that all yellow color changes are dependent on the feed, coarseness of skin, and size of bird. A heavy bird fed on an abundance of green feed or other material that will color the fat deep yellow will not bleach out nearly as quickly as a smaller or paler, colored bird.

The eyering, that is, the inner edges of the eyelids, bleach out a trifle slower than the vent. The ear-lobes on Leghorns and Anconas bleach out a little slower than the eyering, so that a bleached ear-lobe means a little longer or greater production than a bleached vent or eyelid.

The color goes out of the beak, beginning at the base, and gradually disappears until it finally leaves the front part of the upper beak. The lower beak bleaches faster than the upper but may be used where the upper is obscured by horn or black. On the average-colored, yellow-skinned bird, a

bleached beak means heavy production for at least the past four to six weeks.

The shanks are the slowest to bleach out and hence indicate a much longer period of production than the other parts. The yellow goes out from the scales on the front of the shanks first and finally from the scales on the rear. The scales on the heel of the shank are the last to bleach out and may generally be used as an index as to the natural depth of yellow color of the bird. A bleached-out shank usually indicates fairly heavy production for at least fifteen to twenty weeks.

The yellow color comes back into the vent, eyering, earlobes, beak, and shanks in the same order that it went out, only the color returns much more quickly than it goes out. A vacation or rest period can sometimes be determined by the outer end of the beak being bleached and the base being yellow.

Body Changes Due to Laying.—A laying hen has a large, moist vent showing a dilated condition and looseness as compared with the hard, puckered vent of a non-laying hen.

The whole abdomen is dilated as well as the vent so that the pelvic arches are widespread and the keel is forced down, away from the pelvic arches, so as to give large capacity. The more eggs a bird is going to lay the following week the greater will be the size of the abdomen. The actual size of the abdomen is, of course, influenced by the size of eggs laid and by the size of the bird.

Heavy production is shown by the quality of the skin and the thickness and stiffness of the pelvic arches. Fat goes out from the skin and body with production, so that the heavy producers have a soft velvety skin that is not underlaid by layers of hard fat. The abdomen in particular is soft and pliable. The sternal processes are very prominent and are generally bent outward. The thicker and blunter the pelvic arches and the greater the amount of hard fat in the abdomen the less the production or the longer the time since production.

One of the finer indications, but yet one of the most valuable in picking the high layer, is the fineness of the head and the closeness and dryness of feathering. The head of a high layer is fine. The wattles and earlobes fit close to the beak

and are not loose and flabby. The face is clean-cut. The eye is full, round, and prominent, especially when seen from the front. The high layer is trimmer; that is, the feathers lie closer to the body, and after heavy production the oil does not keep the plumage sleek and glossy but the plumage becomes worn and threadbare.

Changes in Secondary Sexual Characters.—The comb, wattles and ear-lobes enlarge or contract, depending on the ovary. If the comb, wattles, and ear-lobes are large, full, and smooth, or hard and waxy, the bird is laying heavily. If the comb is limp the bird is only laying slightly, but is not laying at all when the comb is dried down, especially at molting time. If the comb is warm it is an indication that the bird is coming back into production.

Molting.—When a bird stops laying in the summer she usually starts molting. The later a hen lays in the summer or the longer the period over which she lays, the greater will be her production, so that the high producer is the late layer and hence the late molter. The length of time that a hen has been molting or has stopped laying can be determined by the molting of the primary feathers. It takes about six weeks to completely renew the primary feathers next to the axial feathers and an additional two weeks for each subsequent primary to be renewed.

A bird molts one feather tract at a time, usually alternate tracts. A bird may grow feathers and lay, but does not lay while dropping feathers. All secondary feathers may be dropped at the same time, but this is not true of the primaries.

Temperament and Activity.—A good layer is more active and nervous and yet more easily handled than a poor layer. A high layer shows more friendliness and yet elusiveness than a poor bird. A low producer is shy and stays on the edge of the flock and will squawk when caught.

KEY TO PHYSICAL INDEX METHOD OF JUDGING LAYING CAPACITY (AS WORKED OUT ON S. C. WHITE LEGHORNS)

Vent.—The vent becomes bleached after about 3 eggs have been laid.

Eyering.—The eyering becomes bleached after the hen has laid about 5 eggs.

Ear-lobes.—The ear-lobes are bleached after the hen has laid about 10 eggs. The ear-lobe scores are as follows: Enamel white, 1; Light cream, 2; Light lemon, 3; Lemon, 4; Light orange, 5.

Beak.—The base of the upper beak becomes bleached after about 15 eggs have been laid. The lower beak becomes bleached after about 20 eggs have been laid. The middle of the upper beak becomes bleached after about 25 eggs have been laid, and all yellow leaves the tip of the beak shortly after the 30-egg limit has been reached. Note: With pullets indoors getting no green feed, and with Leghorns in particular, the bleaching will be much faster than where the birds run at large and secure plenty of green feed.

Shanks.—Shank scores are as follows: Pink or white, 1; Cream, 2; Lemon, 3; Light orange, 4; Orange, 5. Note: The color will be laid out of the front of the shanks of a Leghorn when about 40 eggs have been laid, and of a Red when about 60 eggs have been laid. Black shanks will lose pink and become white and lose its shininess.

Comb.—Comb texture scores are as follows: Oily, soft, and pliable, 1; Very pliable, 2; Slightly pliable, 3; Quite hard, 4; Dry, hard, and stiff, 5. Note: The comb is an expression of the ovary. The comb of a laying hen at the time of ovulation becomes filled with blood, congested, red, and oily, soft, and pliable, not coarse and pebbly, but with a certain degree of firmness and heat. As a hen takes a short vacation the tips of the comb shrink first.

Molt.—Molting scores are as follows: Not molting, 1; Neck molt, 2; Body molt, 3; Wing molt, 4; Complete molt, 5.

Abdomen.—In a non-laying hen the fat accumulates in the abdominal wall and the wall becomes hard to the touch. As she again comes into laying the abdomen becomes soft and the skin becomes kid-glove-like in texture. The abdominal scores are as follows: Soft, 1; Hard, 2.

Capacity.—As indicated by span from the sternum to the pubic bones: 5 finger's breadth, 1; 4 finger's breadth, 2; 3 finger's breadth, 3; 2 finger's breadth, 4; 1 finger's breadth, 5.

Pubic Span.—As indicated by the space between the pubic bones: 4 finger's breadth, 1; 3 finger's breadth, 2; 2 finger's breadth 3; 1 finger's breadth, 4.

Thickness of Ischium.—Score as indicated by thickness of bone: Thin, 1; medium thick, 2; thick, 3.

Position of Lateral Sternal Processes.—Score as indicated by position of process: Tendency to be forced down and out, 1; tendency to be parallel to the long axis of the sternum, 2.

Length of the Toe Nails.—Short, 1; medium short, 2; long, 3.

Disease.—Absence of disease, 1; presence of disease, 2.

Laying Now.—As indicated by full, moist, flabby, large vent.

Positive, 1; negative, 2.

Estimate laying past year on above indications.

Actual laying as told by the trap nest.

SCORE CARD FOR JUDGING FOR EGG PRODUCTION

Vent	Eye-ring	Ear-lobe	Beak	Shanks	Comb	Molt	Abdomen	Capacity	Pubic span	Thickness of ischium	Position of lateral processes	Toe nails	Disease	Laying now	Estimate	Actual

Age Identifications.—As a bird becomes older the scales do not lie so closely, have a tendency to become rough and possibly scaly leg develops, though the scab parasites may be contracted by the chick from the hen brooding it. There may be a loss of points of the comb due to freezing. The spurs have a tendency to turn up with age. The degree of development of the spur is useful in estimating the age. As a rule the primary feathers, one each year, commencing at the axillary feathers, become shorter each year; however this is not always

accurate. The posterior point of the keel changes from cartilage to bone and becomes less flexible as the bird ages. The pubic or "lay-bones" also become less flexible as age progresses. The scale at the base of the toe covering the joint in the pullet is flexible, but not so in the old hen. The pads of the feet are softer in the pullet than in the hen. The expression of the face is a factor in telling age, the face of the old hen becoming wrinkled.

Selecting for Meat Quality.—In all utility fowls the breast should be well covered with flesh. The bird should be strong, vigorous, and true to the type of the breed to which it belongs. The back should be broad with well developed muscles. A fattened bird with best meat qualities should have a kid-glove texture or feel to the skin. The skin should be thin, not thick and rough. A bird not bred for full breast or not fattened will have a rough harsh touch. There is a possibility of having too deep a breast; if deep it must be well covered with flesh so as to make a plump appearance. A bird with a warped or sprung keel, one with knots and dents, should not be bred. Select birds with straight keel, with deep well covered breast bones. Avoid the deep prominent edge. The flesh should not be too hard. Observe the posterior edge of the ischial bone to determine for fatness. If the bird is fat this prominent point will show yellow and plump. A meat type bird has a thick pelvic arch with muscles well developed.

The flavor of the meat depends largely upon the kind of feed upon which the bird is fed.

A bird of 5 pounds' weight is sufficient for a family of six.

In a market bird the two most important points are fullness of breast and quality.

JUDGING FOR UTILITY

General Considerations.—Allow for standard shape, 50 points; for standard color, 50; for egg production, or for meat production, characteristics, 100; total score; 200.

Pen.—When pen contains 1 male to 4 females allow one-half of score to the male, one-half to the females. When pen contains 1 male to 9 or 10 females, allow one-third to male,

two-thirds to females. Uniformity should be considered. Individuals of same general shape, size, type, and color are always more desirable than a pen of good individuals but of different types.

Size.—Preference to be given to birds medium to large in size. Extremely small hens usually lay small eggs. Extremely large ones not best layers. Highest producers usually medium in size.

Disqualifications.—Evidence of contagious disease. Decided evidence of mongrel or cross breeding.

DESCRIPTION OF MALE

Condition.—Good health and reasonably well fleshed. Excessively pale, purple or yellow comb denotes poor health. Drooping tail denotes poor condition. Free from parasites.

Carriage.—Slightly more erect than female as this is natural characteristic of male. Extremely erect not desirable.

Activity, Intelligence, and Friendliness.—Active and busy. Elusive but not flighty. Tame and friendly when handled.

Gallantry and Fighting Ability.—Calling the females continually. A good scrapper and crower.

Head-shape.—Moderately fine, without over-hanging eyebrows or other signs of extreme coarseness.

Loss of fat from the head not expected as in the female. The comb medium to large but not excessive in size.

Body-shape.—Broad, indicating full capacity and vitality. A triangle from front to back but not excessively so. This desirable character may be transmitted to his daughters.

Legs, Toes, Neck, Wings, and Tail.—Strong shanks well apart, indicating good vitality, and of fair length to give him free action so he can work and forage well. The nails fairly well worn, indicating that he has been scratching for food and calling the hens to eat what he could find. Neck and wings well proportioned. Tail carried according to standard requirements of the breed.

Plumage.—Comparatively close feathering with due allowance for breed. The American and English classes naturally have looser feathering than the Mediterranean class. Loose

feathering with heavy layers of fat underneath the skin is indicative of meat type.

Skin Texture.—Thin, soft, pliable, oily, and loosely fitting on body, indicating good condition and activity. No change in the skin color as in the female.

FEMALE

Condition.—Good health. An excessively purple, pale or yellow comb indicates poor health. Drooping tail denotes poor condition. Free from parasites.

Carriage.—High producers tend to carry body so that back is horizontal, not erect.

Activity, Intelligence, and Friendliness.—Elusive but not flighty. Poor layers are sluggish or wild. Good layers are active, hunting for food, and are tame and friendly when handled.

Head (Including Comb, Wattles and Ear-lobes).—Head and face fine, free from wrinkles and fat deposits. Not thin enough to give crow-headed appearance or indicating low vitality or sickness. Comb should be full and firm, preferably firm enough to be waxy, an indication of heavy laying. It is usually pale red during or just following heavy laying. Medium to large in size as there is a certain amount of relation between size of comb and size of the egg the hen lays. Wattles should be in proportion to the comb and well up toward lower part of beak. Ear-lobes should be full and smooth.

Body.—Large enough for good capacity. Broad and deep enough to afford room for good sized digestive organs. A triangle from front to rear. Not excessively long.

Legs, Toes, Wings, Neck and Tail.—Legs well apart, sturdy but in hens thin and fine on the back side, denoting production. Plump on pullets. Toenails worn short by work, the length depending upon nature of henhouse floor. The wings should be held up well to denote production. The neck moderate in length. Excessively high tail a matter of breeding and undesirable. Tail liable to be pinched during laying period.

Plumage.—Varies according to season. Heavy layers are busy, hence feathers soon become worn. Preference to be given to late molting hens in the fall and early winter months. Pullets will become closer feathered as the body fat is used in egg production.

Skin Color.—In varieties having yellow skin the color of the skin all over the body, especially vent, eye-ring, ear-lobes, beak, and shanks will indicate egg production by bleaching out. The more they bleach or fade the greater has been the production. This color returns in the order named when laying ceases.

Meat Qualities.—In birds bred for meat production the breast should be deep and well fleshed out. The breast bone should be free from deformities. The skin should be soft and kid-glove-like to the touch. The pelvic bones thick with well developed muscles. The body should have good depth and length and well developed muscles giving an abundance of meat. The back should be moderately broad.

MENDELISM

Mendel first gave to the world the proved fact that anatomic units were characters inheritable.

Altered anatomic units due to environment, that is, post-natal deviations, are not inheritable. Thus a dog's tail may be cut off, but his progeny would not be tailless dogs due to the fact that their parent had his tail cut off. A cow may be dehorned, but her progeny will not be hornless due to the fact that their mother had her horns cut off. Tailless dogs and hornless cattle are originally "sports" and are readily explained by the laws of Mendel. The Jews have practiced circumcision since time immemorial, yet they still find circumcision possible. No better concrete example can be given than this for the Orthodox Jew is supposed to marry only within his own race.

It was Weismann who first showed that the inheritable factors we may call unit characters are transmitted through the germ plasm. There remains little doubt, after his exhaustive studies, but that it is the microscopic granules or micro-

somes composing the chromosomes of the nuclear network that transmit characters good, bad, and indifferent.

In regard to reproduction it may be said that in mammals, where the young are parasitic upon the mother during the earlier stages of their growth, the egg or germ cells are minute (microscopic in size) and contain only a small amount of yolk, called deutoplasm, that enables them to reach the stage at which they develop the processes for attaching themselves to the wall of the mother's uterus.

In the bird the contents of the egg form the source of food or nutrients for the developing young and for more than seventy-two hours after emerging from the shell, and hence are very large in comparison to the size of the animal producing them.

The sexual cells of the male are very small (microscopic in size) and are produced in the testes or male generative gland. The ova does not possess the power of movement while the male element or spermatozoa are endowed with active movement. In the bird they take the form of a long whip, with slender lash or filament. By aid of this flagellum they move about in any liquid they happen to be deposited in in search of the ova.

In the reproduction of animals or plants there are two sexual cells. The female cell in the animal is called ovum and in plants ovule. The male element is called a spermatozoön in the animal and pollen (a grain) in the plant. These are known by a general term, gametes or marrying cells.

The new individual is formed by the union or fusion (yoking together) of a male and female gamete and is called a zygote.

Therefore the zygote is a double structure, in which components brought in by each of the gametes remain intimately fused in a form of partnership.

When later this zygote in turn forms gametes this partnership is broken and the process is reversed. In other words, the component parts of the double structure are resolved, with the formation of gametes, into single structures.

From this the life cycle of a bird may be divided into—First, a period of isolation in the form of a gamete and living as a single unit awaiting the union with the gamete of the opposite sex to make possible further development; second, the period

of union of the two gametes forming the zygote and cell division and formation of a fully developed individual, and third, the separating out of the single structured gametes from the individual or double-structured zygote through its generative gland.

Nature's scheme of inheritance was first worked out on plants.

Mendel crossed the tall pea (6 feet in height) on a dwarf pea (1.5 feet high), and, although each kind of plant had been proved to breed true to height, if they were crossed artificially, using either as the pollen parent, the other being used as the ovule parent, the result of crossing tall with dwarf was in every

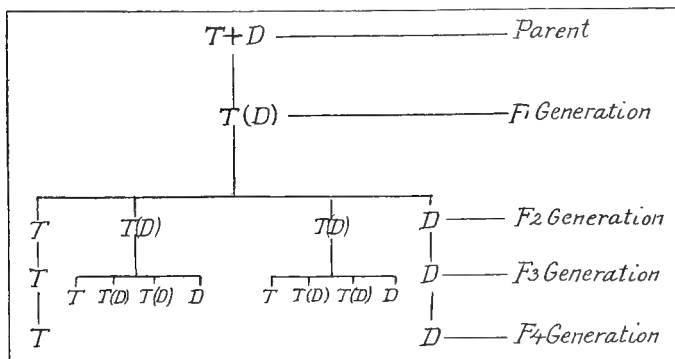

FIG. 41.—Mendel's illustration of inherited characters: *T* is for dominant tall, *D* is for recessive dwarf.

case nothing but tall. This tall character, because it dominated, was called the dominant character. The dwarf character was called the recessive character. The progeny was the F_1 generation (Fig. 41). Seeds from this F_1 generation sown the following year gave rise to tall and dwarfs with no intermediates. This formed the F_2 generation, the tall numbering three to the dwarfs one. From the F_2 generation the seeds collected from the dwarf recessive always produced dwarfs. On the other hand, the seeds of the tall, though in physical appearance indistinguishable, some bred tall and some produced both tall and dwarfs in the usual proportion of three

of the talls to one of the dwarfs, and the number of talls that produced some dwarfs was two to one.

The diversity of characters which followed the laws of transmission appears before our eyes every day in observing the progeny of birds we breed by the character produced in feather pattern—from the feathers and of comb.

Mendel taught that in each gamete there was either a definite faculty for the production of a recessive character or a dominant character. These he called factors. These factors, then, may be considered the unit characters which appear in the development of the zygote.

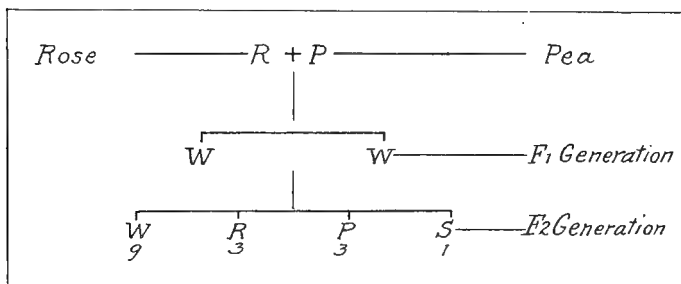

FIG. 42.—Mendel's chart showing the result of breeding various varieties of combs of fowl. *R*, Rose comb; *P*, pea comb; *W*, walnut comb; *S*, single comb.

In our example above tallness in the pea would be considered a unit character, therefore the gametes containing this unit character contain the factor for the production of tallness.

Thus, in the structure of the feather we find the shape of the common type feather formed by barbules holding together the barbs preserving the usual shape. In the silky fowl the barbules are absent, and the barbs without support are not held together and a silky coat presents itself. This silky condition is recessive.

In the **production of the proper comb** the breeder is constantly battling in an effort to secure and fix the proper unit character or factor.

Thus, experiments have shown that the rose comb is dominant in the ordinary way to the single comb, such as

possessed by the Single Comb White Leghorn, and it has also been shown that the pea comb is dominant to the single comb.

Thus we see two dominants in the rose and pea combs. When a rose comb is crossed on a pea comb a new type is formed, that of the walnut comb (so-called because it resembles half of a walnut).

According to Fig. 42, we will see that the F_2 generation, that is, the progeny of the rose comb and pea comb crossed on each other, produced four types of combs, as follows: 9 walnut, 3 rose, 3 pea, and 1 single. According to Punnett, these are always produced in this proportion.

In the analysis of the above we conclude that the walnut comb contains both dominant characters, the pea comb and rose comb one dominant each, and the single comb as a pure for both recessive characters.

The pea comb and rose comb factors are distinct and separate entities which, when combined, have an influence on each other in the zygote, producing the walnut comb which is not an intermediate between the two.

When one of these factors are alone in the zygote its influence in the single comb factor is different; that is, producing a pea comb if a pea comb factor or a rose comb if a rose comb factor.

The single comb is the form found in the wild jungle fowl, the *Bankiva*, which is said to be the ancestor of all our domestic fowl. If this be true the reversion to the single comb in the F_2 generation is easily explained. It is a reversion pure and simple, the recessive factor coming to the surface. This is considered as due to the association of two complimentary absences.

Punnett found that by crossing a White Dorking on a White Silky fowl, both of which had been shown to behave as simple recessives to color, the F_1 generation consisted of colored birds; the F_2 generation consisted of colored and white, in the ratio of nine to seven. This is, in reality, the 9 : 3 : 3 : 1 ratio as observed in a study of the crossing of comb characters. The 3 : 3 : 1 factors are indistinguishable because they cannot produce visible effects without the co-operation of each of these section factors.

Another excellent illustration is shown in the breeding of

the Blue Andalusian fowl. It is difficult to secure a slaty-blue color, with darker hackle and with dark lacing of feathers on the breast. The off colors are white splashed with black and blacks.

By making a careful study in breeding these blues it will be found that there will always be produced one black, one splashed white, and two blues; the blues are heterozygous, and the splashed whites and blacks are homozygous, forms.

If the whites are bred together they will be found to always breed white. Likewise, if the blacks are bred together they will always breed black, but if the blacks and white are bred together they produce nothing but blues; that is, the off colors breed twice as many blues as when the blues are bred together. Therefore the blacks and the whites are the pure breeds, while the blue is a mongrel who can never be bred so as to always breed true.

There are a few instances where a visible distinction can be drawn between a pure dominant and a heterozygote. Certain white breeds, as the White Leghorn, in which white behaves as a dominant color; heterozygous whites, made by crossing the dominant white birds with pure colored forms, as the Brown Leghorn or even the Spangled Hamburg, almost invariably show ticks in their plumage.

This shows the white dominance is not quite complete in the White Leghorn

Punnett suggests that the dominant white fowl may be a colored bird plus a factor which inhibits the development of the color.

The Spangle in the Silver Spangled Hamburg is a genetic factor and is carried in the sex chromosome of the male. It follows the sex link of inheritance.

MONOHYBRIDISM AND DIHYBRIDISM

Mated pairs differing only in a single pair of characters are known as cases of **Monohybridism**. Where the original parents differ in two pairs of characters the case is termed one of **Dihybridism**.

Take the case of a cross between the rose-comb Black

Hamburg and the single-combed White Leghorn. In this case the rose-comb is dominant over the single-comb and the white plumage is dominant over the black.

Let the rose-comb be represented by R, dominant.

Let the single-comb be represented by s, recessive.

Let the white plumage be represented by W, dominant.

Let the black plumage be represented by b, recessive.

Then

$$R_s \times R_s = RR + 2R_s + ss,$$

and

$$W_b \times W_b = WW + 2W_b + bb.$$

i.e. when two hybrids are mated together the resulting progeny (on the average) is **one** like the dominant parent, **one** like the recessive and **two** with the qualities of both the dominant and the recessive, *i.e.*, in mating a white fowl with a black fowl (in cases where the white is dominant), the result will be one pure white (W), which will continue to breed white; one pure black (b), which will continue to breed black; and two white fowls, which carry black as a dominant or recessive quality. These two are hybrids, which will breed the same as their parents.

What is true of white plumage applies to the rose-comb.

Dihybridism.—In the cross between the Black rose-combed Hamburg and the White single-combed Leghorn we have a case of dihybridism. The average result of such mating will be shown by the algebraic formula

$$(RR + 2R_s + ss) \times (WW + 2W_b + bb)$$

In working out this simple formula we may place the symbols multiplied, in any order, thus WR, which expresses the dominance of white plumage and rose-comb, is equally correct if put down as RW. If I wish to express the white plumage I put the W first, and the result is—

WWRR	WbRR	WbRs	bbRR
WWRs	WbRR	WbRs	bbRs
WWRs	Wbss	WbRs	bbRs
WWss	Wbss	WbRs	bbss

This shows that out of every 16 of the progeny there will be on the average 12 chickens with white plumage and 4 with

black, *i.e.*, 3 white to 1 black. It also shows that of the 12 whites 4 will be pure, since each gamete is pure (WW), and 8, though white because white is dominant will carry black as a recessive (Wb). By the same table of symbols I find there are 12 rose-combs as R is present in 12 cases, but only 4 pure, where (RR) occurs, and 8 impure (Rs), and that there are 4 pure single-combs (ss).

If I tabulate for rose-combs it appears more simple as—

RRWW	RsWW	RsWb	ssWW
RRWb	RsWW	RsWb	ssWb
RRWb	Rsbb	RsWb	ssWb
RRbb	Rsbb	RsWb	ssbb

The tables show me that I get 3 rose-combs to 1 single-comb, 3 whites to 1 black, and that taking both pairs of characters together there will be out of every 16 chickens, 9 rose-combed whites, 3 rose-combed blacks, 3 single-combed whites, and one singled-combed black.

A glance at the table will show me the proportion of chickens which will breed true, *viz.*, those which are homozygous for both pairs of characters, *e.g.*, RRWW will breed pure rose-combed whites, and RRbb will breed pure rose-combed blacks, ssWW will breed pure single-combed whites, and ssbb will breed pure single-combed black.

If the 9 rose-combed whites are taken to breed together, on the average only 1 will breed true, designated above RRWW, 2 will throw a proportion of single-combed whites (RsWW). 2 will throw also rose-combed blacks (RRWb), while the other 4 will throw both single-combed whites and single-combed blacks (RsWb), as well as rose-combs of both colors.

The awkward part for the breeder is that he is not able, with present knowledge, to tell which will breed true, from outward appearance, but has to test his breeders in these cases by actual experiments, except in the cases above mentioned, for he knows, *e.g.*, that the single-combed black will breed true.

These results may be tabulated as below, showing both the outward appearance and the breeding qualities of each chicken, taking the first of the above lists in order—

No.	Symbol	Outward Appearance		Breeding Qualities
		Color	Comb	
1	*WWRr	White	Rose	Will breed white rose-combs with no taint of cross. A new variety. Will breed $\frac{1}{4}$ pure white rose-comb. Will breed $\frac{1}{4}$ pure black rose-comb. Will breed $\frac{1}{2}$ impure white heterozygotes like parents.
2	WbRR	White	Rose	
3	WbRR			
4	*WWss	White	Single	Will breed white single combs only, with no taint of cross.
5	WbRs	White	Rose	These organisms having both pairs of characteristics are dihybrids like the parent stock, and will breed as represented in this table. These will breed white rose-combs and white single-combs in the proportion of 1 rose-comb white pure, 1 single-comb white pure, and 2 rose-comb white heterozygotes like their parents (WRs). These will breed white single-combs and black single-combs, viz., 1 single-comb white pure + 1 single-comb black pure + 2 single-comb impure whites, represented by formula $sW + 2sWb + sb$. These black rose-combs will breed in the proportion of 1 black rose-comb pure + 1 black single-comb pure and two impure single rose-comb blacks = $bR + 2bRs + bs$.
6	WbRs			
7	WbRs			
8	WbRs			
9	WWRs	White	Rose	
10	WWRs			
11	Wbss	White	Single	
12	Wbss			
13	bbRs	Black	Rose	
14	bbRs			
15	*bbRR	Black	Rose	Pure black rose-comb with no taint of cross.
16	*bbss	Black	Single	Pure black single-comb with no taint of cross. A new variety.

* Those marked* are pure for both characters.

The example of the Black rose-combed Hamburg with the single-combed White Leghorn has been worked out in such

detail to show the nature of Mendel's discovery of the law of **Gametic Segregation**.

It is one of the most marvellous of the discoveries of science that by means of this law the breeder is able to predict beforehand the result of mating his stock. He may take a pair of these cross-bred fowls, both white plumage and rose-combs, and knowing their pedigree, *i.e.*, their gametic heritage, can tell the number of rose-combs and single-combs of white plumage or black plumage which he will get. The gain to the breeder is enormous. Although the parents were heterozygous (*i.e.* in common parlance mongrels), he gets four birds out of the sixteen, one-fourth of the group, which will breed true, *viz.*, the rose-combed white (WWRR), the single-combed white (WWss), the rose-combed black (bbRR), and the single-combed black (bbss), and that of these four two of them, the (WWRR) and the (bbss), are **new forms**, new varieties, proof of the theory of Discontinuous Variation. These are marked with an * in the tabulated list.

Mendel's Theory Summarized.—"Mendel discovered an important set of facts, and he also suggested a theoretical interpretation—the theory of gametic segregation. As Mr. Bateson says: 'The essential part of the discovery is the evidence that the germ-cells or gametes produced by cross-bred organisms may in respect of given characters be of the pure; paternal type, and consequently incapable of transmitting the opposite character; that when such pure similar gametes of opposite sexes are united in fertilization, the individuals so formed and their posterity are free from all taint of the cross; that there may be, in short, perfect or almost perfect discontinuity between these germs in respect of one of each pair of opposite characters'" (Professor Thompson, *Heredity*, p. 347).

"The essential feature of Mendel's discovery is the segregation in the gametes of the factors corresponding to the dominant and the recessive characters" (R. C. Punnett, *Mendelism*, p. 30).

"The breeding pen is to us what the test tube is to the chemist, an instrument whereby we examine the nature of our organisms and determine their genetic properties" (Bateson).

This principle of gametic segregation and the modes of its action in the breeding pen I have endeavored to point out in the tabulated list.

Each group of symbols represents a number of characteristics, sometimes containing both units of pairs of characteristics, *e.g.*, WbRs represents that the fowl in question has the gametes for white plumage and black plumage, for rose-comb and single-comb, and possesses them **in equal numbers**.

In the sperm-cell or egg-cell which it imparts it may give off a gamete representing white plumage (W) or a gamete representing black plumage (b), but not both at the same time, *i.e.*, not a gamete representing half white and half black. The gametes are distinct units. They are segregated, *i.e.*, divided, separated, one from the other. What is true of color applies in the same way to the comb, and also to other Mendelian characteristics, if present. As an illustration, it may be said that they lie side by side like the numerous sections or "quarters" in an orange, each contained in its own envelope, while the cell-like fruit within the segment may represent as many distinct units of many pairs, but not the two distinct characteristics of any pair.

How this segregation of the gametes, which represent the dominant and recessive characters, takes place in the organism is at present unknown, though it is not impossible that the further studies and researches of embryologists may discover it.

What is important is the fact, proved by abundant experiment, that these two "potential unit characters" do segregate, and that the adult organism cannot have both. "Intermediate forms or blends do not occur in Mendelian phenomena."

In describing the ratio of their transmission by hybrid organisms, the expression "on the average" has to be used. There is no proof that they are given off alternately, though it is assumed that they are present in equal numbers. It is not to be taken as proved that the group of sixteen inheritances I have given will be present in the exact order in each sixteen of the offspring, though if the number be multiplied by ten it would be found that they would be very near the number given.

Chance Fertilization.—It is much the same as in a game of chance. If there were ten sets of the table of sixteen placed in a lucky bag we should not expect the one (WWRR) and the one (bbss) to be drawn with each sixteen, although we know that there would be ten of each drawn by the time the one hundred and sixty tickets had been drawn.

This is the common experience of breeders. It sometimes happens that the best birds of the year's breeding come all at once, at some period of the season, while at other times they are fairly evenly distributed all through.

It is like the game of whist. Each player knows that there are four aces in the pack, and that four out of fifty two cards are of this nature and are dealt every time. The average is absolute, but the individual chance of getting one ace each hand is uncertain.

In an experiment there were bred a number of Rose-comb Buff Orpingtons. Both parents had rose combs, but there was produced a fair proportion of single comb chickens. These were the recessives, bred because one of the parents was a D.R. and not a pure dominant. The single-comb recessives were not bred together, but there were mated two single-combed pullets bred in this way to a pure single-combed Buff Orpington cock. In this case there was a pure single comb and a recessive single comb, which should have bred pure single combs, but the result was a third of apparently pure rose combs, and some of the single-combed chicks has side spikes, as if a trace of the rose-combed blood showed itself in the hinder part of the single comb.

These rose-combed chicks continued to be bred from the single-combed progeny for two generations. This shows the dominance of the rose comb, but it also shows that the dominance may lie dormant in a recessive character, and when fresh blood is introduced may take the opportunity of a new combination to reassert itself.

The recessive character may therefore be incomplete as well as the dominant; but the occurrence is so rare that the exception may be taken as proving the rule.

LIST OF DOMINANT AND RECESSIVE CHARACTERS IN POULTRY

No.	Character	Dominant	Recessive	Notes
1	Comb	Rose	Single	As Wyandotte or Hamburg, over any single-breed.
2	Comb	Leaf	Single	Cf. Houdan-Leghorn.
3	Comb	Rose	Leaf	
4	Nostril	Narrow, low nostril	High nostril	{ Shown in crosses with Polish, or Houdan, and fowl like Minorca and Game with normally shaped heads.
5	Cerebral hernia	No hernia	Hernia	
6	Crest	Crested	Smooth head	All first crosses with Houdan or Polish show traces of crest.
7	Muff	Muffling	No muff	{ Crosses with Houdan or Faverolles show diminished muffs and beards in the progeny, which segregate in F ² .
8	Beard	Bearded	No beard	
9	Ear-lobe	Red	White	White is a new character, and red is difficult to breed out.
10	Eye	Black iris	Red iris	{ The red eye is the ancient character of the <i>Gallus Bankiva</i> , and though recessive to black yet is a stubborn recessive, and though latent constantly reasserts itself. Pearl is frequently dominant over red.
11	Eye	Red iris	Pearl iris	
12	Eye	Dark brown	Red iris	
13	Beak	White	Horn	{ Both ancient colors. Sometimes one is dominant and sometimes the other. Black the most dominant character, then yellow.
14	Beak	Black	Yellow	
15	Beak	Yellow	Horn	
16	Skin color	Black	White	White and yellow skin are both ancient. Cf. Silkie with black skin is dominant, Davenport.
17	Skin color	White	Yellow	E.g. Dorking over Indian Game, or Cochin.
18	Shanks	Feathered	Clean	{ Cf. Cochin-Leghorn. Cochin feathering has been bred out in the Orpington, but still reappears, and the Dorking white has conquered the Cochin yellow.
19	Shanks	White	Yellow	
20	Shanks	Black	Yellow	Black usually dominant, as breeders of Wyandottes and Leghorns know. But yellow sometimes dominates and has covered the Minorca cross in Black Leghorns.

THE PROBLEMS IN MATING AND IN EGG PRODUCTION 129

LIST OF DOMINANT AND RECESSIVE CHARACTERS IN POULTRY.
(Continued)

No.	Character	Dominant	Recessive	Notes
21	Shanks	Yellow	Willow	Both ancient. Willow too often re-asserts itself.
22	Shanks	Blue	Yellow	Rose-comb Leghorn breeders with Hamburg cross will find this a crux, also Blue Leghorn if contaminated with Andalusian blood.
23	Hock	Plain	Vulture	In crosses with Asiatic (vulture-hocked) and Mediterranean breeds (Plain), the plain dominates and disappears much more rapidly than shank feathering.
23A	Plumage	White	Black	All colored plumage is more or less recessive to white, which is a new character, but black sometimes dominates and sometimes mingles to form "blue."
24	Plumage	White	Pigmented	
25	Plumage	Black	Red	But frequently albinism results. Black is imperfectly dominant over red.
26	Wing-coverts	Red	Other colors	Red wing-coverts are an ancient heritage from the Jungle fowl and Red constantly reasserts itself, e.g., Brown Leghorn, Buff Orpington.
27	Shaftiness	Shaftiness	No shaft	A fault in Brown Leghorns, Buff Orpingtons, etc., hard to eradicate.
28	Hackle	Solid black	Laced	E.g., Silver Laced Wyandottes crossed with Black Rocks lose the laced hackle, and many laced birds throw black hackles. Black is imperfectly dominant.
29	Pencilling	Pencilled feathers	Plain	Said to be "a fundamental form of coloration in the genus <i>Gallus</i> ." "A concentric repetition on the feather of alternating bands of the lacing and ground-color," e.g., Partridge Wyandottes. Said by Davenport to be dominant, but is certainly incomplete, and can be easily dominated by black. E.g., when a white and a splashed or a mottled bird are crossed the markings persist through them in a diluted form.
30	Splashing	Splash	Plain	
31	Mottling	Mottle	Plain	

LIST OF DOMINANT AND RECESSIVE CHARACTERS IN POULTRY.
(Continued)

No.	Character	Dominant	Recessive	Notes
32	Tail	Black	Other colors	Black pigments persists in the tail <i>e.g.</i> , Cochin and Orpington), much more than in any other part of the plumage. It is an ancient heritage of the race.
33	Tail	Tailed	Rumpless	The Rumpies are modern and eccentric.
	Tail	Tail unlimited	Normal tail	<i>E.g.</i> , the Yokohamas are dominant over normal tails.
34	Color of egg-shell	Brown	White	When the Mediterranean breeds (white-shelled eggs) are crossed with Asiatic (brown), the brown dominates, and the eggs are tinted. And the tinted egg is one sign among others of a cross, <i>cf.</i> , Leghorn and Minorca eggs often tinted.
35	Broodiness	Sitting	Non-sitting	Incomplete dominance until the "sitting" blood preponderates, <i>e.g.</i> , a "sitting" Minorca or Leghorn is not reliable in its broodiness.

LINE BREEDING, OUTCROSSING, AND INBREEDING

Breeding together of sire and offspring, or of dam and offspring, or of brother and sister, is inbreeding, or breeding in and in.

That veteran breeder of pure-bred poultry, I. K. Felch, has to say of line breeding, "deterioration commences the moment there is no change in the blood proportion in the chick with that of sire and dam. The accompanying chart (Fig. 43) shows the progeny of a single pair of birds, a male and a female. It is possible to raise a thousand chickens from a single pair, retaining their health and vigor and egg production inherited by the original pair by careful selection and mating of the progeny."

In the chart the dotted line represents the females as having been selected from the upper group, while the solid line shows the males as having been taken from the indicated upper group. Each circle represents the progeny. Female

number 1 is mated with male number 2, having produced group number 3, which is one-half the blood of the sire and dam.

Females from group number 3, mated to their own sire number 2, have produced group number 5, which is three-fourths of the blood of the sire number 2 and one-fourth the blood of the dam number 1.

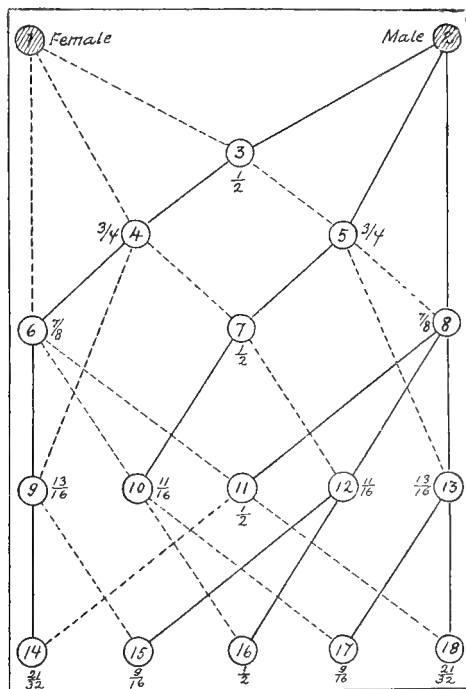

FIG. 43.—The Felch breeding chart. Line breeding.

A male from group number 3, mated back to his own dam, number 1, produces group number 4, or vice versa, which will produce group number 7, which is mathematically half the blood of each of the original pair, numbers 1 and 2. This is a second step toward producing a new strain.

Females from number 8, mated back to the original male,

number 2, produce group 8, that are seven-eighths the blood of number 2, and a cockerel from number 4, mated back to the original dam, number 1, produces group number 6, that is, seven-eighths the blood of the original dam and only one-eighth the blood of the original sire.

Again we select a male from number 8 and female from number 6, and for a third time produce chicks (in group number 2) that are half the blood of the original pair. This is the third step and the ninth mating in securing complete breeding of our new strain. In all this we have not broken the line of sires, for every one has come from a group in which the preponderance of blood was that of the original sire. Numbers 2, 8, 13 and 18 are virtually the blood of number 2.

We have reached a point where we would establish a male line whose blood is virtually that of the original dam, and we mate with a female from number 4 and produce group number 9, which is thirteen-sixteenths the blood of the original dam, number 1, and three-sixteenths the blood of the original sire.

Again we select a male from number 9 and a female of the new strain, number 11, and produce group number 14, which becomes twenty-one thirty-seconds of the blood of the original dam, thus preserving her strain of blood.

A male from number 13, which is thirteen-sixteenths the blood of the original sire, number 2, mated to females from number 10, which are five-sixteenths the blood of the original sire, number 2, gives us group 17, which is nine-sixteenths the blood of the sire.

While in number 16 we have the new strain and in number 18 the strain of our original sire, number 2, we have three distinct strains, and by and by, with this systematic use, we can go on breeding for all time.

By the accompanying chart it is easily seen that if one was to mate sire and dam from either of the groups 3, 7, or 11 there would be no change in the blood, and if we should continue these with their offspring for three generations we would find it difficult to hatch more than 3 per cent. laid by these three generations from either of the half-blood groups; for all that these 3, 7, and 11 groups are in main spokes in the wheel of line breeding.

So long as we mate so as to create a group of half the blood each of groups 1 and 2, we have a reservoir of blood to mate back to the two lines of blood we have chosen for our line breeding. These groups are the invigorating well of blood that sustains our flocks for all time. When we create a pen of half-bloods in our own yards we have that which renews the energy and vigor of both numbers 1 and 2 strains, while if we go out of our flock for new blood it serves only to invigorate the one, being our male line, number 2.

Our male line should never be crossed by sex, only as we would create a line representing number 1, or the female line as in our chart; where we used male birds from 6 and 9 to establish the strain of the females, we used in our first cross that produced group number 3.

While we have made three matings to produce the half-blood cross for numbers 3, 7, and 11, yet the blood in all three is identically alike, being half the blood of each of numbers 1 and 2, male and female. In all other groups the percentage of blood differs as per the amount we increase the blood of the two strains we employ.

To line breed is simply, in all our matings, to get a preponderance of the blood we desire to maintain; we have produced these flocks to full blood of the sire in group 8 for the male line and in group 6 for the female line.

If one wishes to preserve his flocks in one shape, color, and vigor, his line of sires should never be broken (see black lines of the chart).

Let us suppose a cross were carelessly made. Suppose you mate numbers 15 and 17, and, being pleased with the chicks in 16, you again mate numbers 10 and 12, and again 9, 13, and 18, where would you be? Every chick would be half-bloods, and you are forced back to the old cocks or to introduce new blood to get you out of the trouble.

The whole art of line breeding is to not make mistakes, and to keep each strain of family alone and to each year create a new reservoir of blood.

Halpin's inbreeding experiments show a rapid decrease in fertility and hatchability. The ratio ran as follows: Inbred first generation, 67 per cent. fertility; second generation, 49

per cent. fertility; third generation, 41 per cent. fertility; fourth generation, 18 per cent.

PEDIGREE BREEDING

Meaning of Pedigree.—The pedigree of a fowl is its ancestry. The term is also used to cover the record of this ancestry. In this latter sense, the pedigree of a fowl shows the foundation stock of the breed that enters into his line of ancestry, and then sets forth the various links in the chain of life, including all the various strains introduced by the use of new blood for certain definite purposes.

What Such a Record Will Show.—A study of such a record will often serve to explain cases of reversion to type, as, for instance, how a black feather now and then appears in a white plumage, or blue or yellow legs where they should be white.

Keeping an Accurate Record.—When once the principles of breeding have been mastered, and their importance thoroughly understood, the next step is to apply these principles and keep a complete and accurate record of all the work done.

A Descriptive Record of Each Fowl.—It is important to study each fowl in your breeding pens, point by point, and to write a full description of each bird somewhat as follows:

1. Name or number, sex, date of hatching, weight.
2. Head—size, shape, how held.
3. Beak—length, shape, color.
4. Eyes—color, expression.
5. Face—color.
6. Comb—diagram, kind, lopped or straight, size, color.
7. Wattles—size, color.
8. Ear-lobes—color, size, shape.
9. Neck—length, arch, color.
10. Back—shape, length, color.
11. Tail—length, angle, spread, color.
12. Shoulders—form, size, color.
13. Breast—breadth, depth, shape.
14. Wings—size, setting, color of various parts, how carried.
15. Legs—length, size, distance apart, feathering and color of all parts from thigh to toes.

Value of Such a Record.—Such a record will help you in case you wish to make a sale, or a new mating, as you will

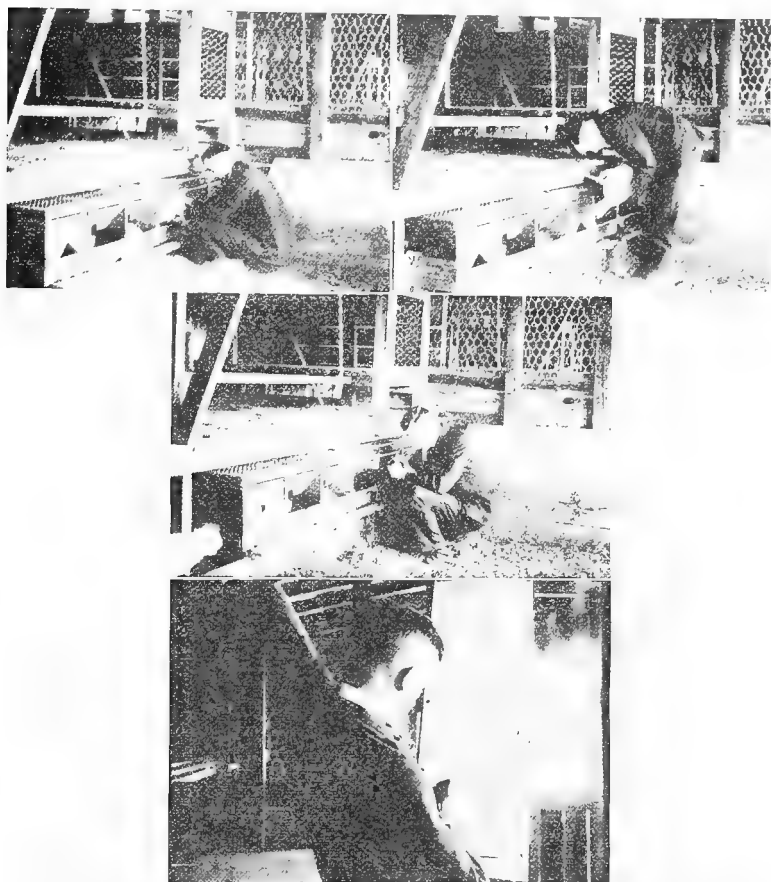

FIG. 44.—Keeping pedigree records of eggs. Taking hen from nest, reading its number, marking number on small end of egg and recording date and hour egg is laid.

not be compelled to examine a lot of fowls to discover just the one you want for a particular purpose.

And you can still further save your time by having a record



FIG. 45.—Incubating the pedigree eggs and leg-banding the chicks for identification. Upper tray testing eggs 7th day.

as to the pen where each bird is kept so that you can easily find it when wanted. This should be supplemented by exact notations as to the characteristics of each fowl, whether alert or slow, timid or assertive, a hustler, up early and late or sluggish.

Trap Nest Records and Leg-banding.—The construction of the trap-nest is given on page 517. The daily egg record card on page 525. The individual annual egg and hatchability record on page 528, and the leg-bands on page 145.

When the eggs are taken from the trap nest, the hen's number is read and placed on the small end of the egg. On the eighteenth day of incubation all of one hen's eggs are placed in a mosquito netting sack and the incubator closed till the hatch is over. When the hatch is over each baby chick is leg-banded and the number recorded together with the number of the dam. The band may be placed around the leg, or it may be placed in the web of the wing or patagial duplicature. If the band is placed on the leg it must be loosened once a week as the chick develops. When the bird is nearly grown a permanent seal band may be placed on the leg. It is a good plan to leave the wing band on as this will give a double check on the bird. (See Figs. 44 and 45.)

CHAPTER IV

FARM POULTRY PROBLEMS

BREEDING poultry on the farm has two objects in view—first, to bring a flock of mixed breeding up to a level of the better individuals of that flock and, second, to fix certain characters, such as large egg production.

The purpose of selection is to prevent the hatching of individuals not suited for production.

In selecting we wish to fix the following characters: First, constitutional vigor; second, high fertility, third, high egg production; fourth, long-lived birds; fifth, early maturing; sixth, other varied characteristics the breeder may wish, such as feather pattern and standard requirements.

Constitutional Vigor.—While proper housing, feeding, incubation, and general care help to conserve the health of the flock the above characters are inheritable. In inbreeding a constitutional weakness may be intensified, and the same as to other characters which are sought, hence great care must be used in selecting breeding stock and mating, and especially keeping uppermost in mind the defects one tries to breed out of the flock.

The greatest manifestation of vigor and vitality are present only where the vital functions, as digestion, assimilation, circulation, respiration, and nervous functions, perform their work in a normal and efficient way. Under such conditions the highest type of vitality and vigor is manifested in the reproductive cells.

If the hen producing the eggs for hatching does not receive the proper quantity of food, there is another chance that a chick of weak constitutional vigor may be produced. The embryo may die before hatching, or the chick may be weak and develop into an adult of low vitality and poor constitution. Evidence of sexual strength in the male is indicated by his



FIG. 46.—A cockerel of weak constitution. Note the lack of vigor and development and attitude.



FIG. 47.—A cockerel showing strong constitutional vigor. Note his head development, broad breast, and erect attitude.

great gallantry, persistence in crowing, challenge, fearlessness in fighting, and sidling strut before the hens.

Heavy laying or high egg production does not decrease hatchability or livability.



FIG. 48.—Hen of weak constitution. Note the lack of head development and weak-appearing eye.



FIG. 49.—Head of hen showing strong constitutional development.

The body of a laying hen is always in good condition, which indicates that the process of reproduction requires good digestion and assimilation.

Egg Production.—It must be remembered that the happy hen is the laying hen, and that fright, improper food, damp, cold floor and yard, too cold, excessively hot weather, irritation by vermin, internal or intestinal parasites, too close confinement with no exercise, causing them to become too fat, or any other discomfort, will radically affect egg production. Not only this but the above conditions tend to lower vitality in both parent and offspring.

It is the desire to have hens that lay a large white egg where we are selling to a market demanding this color shell, or a large



FIG. 50.—Two chicks fourteen days old, one weak the other strong in constitution. The smaller one weighs 0.14 pounds and the larger 0.31 pounds. They were fed the ration given on page 332. Both were from the same breeding pen, eggs stored in the same storage tray, incubated in same incubator tray, brooded in the same brooder, and ate of the same ration.

brown egg if we are selling where the market demand requires this color of shell. Mixed breeds or scrub breeds do not lay a uniform egg, which eggs do not bring the top market price, and the undersized egg likewise brings a lower price than the large egg. It is the desire that each hen lay a large number of eggs each year. It is well to select those which have light pin-feathers and can be easily kept within the yards. In selling dressed carcasses we find that the market looks with disfavor on the dark pin-feathers, and in some markets dressed carcasses with dark pin-feathers bring as much as two cents less than other kinds. Likewise, there is a difference of four or

more cents discrimination in most large markets in favor of the large white eggs as compared to the brown or mixed eggs.

There is a relation between the size of the comb and the size of the egg. The size of the individual governs to a certain

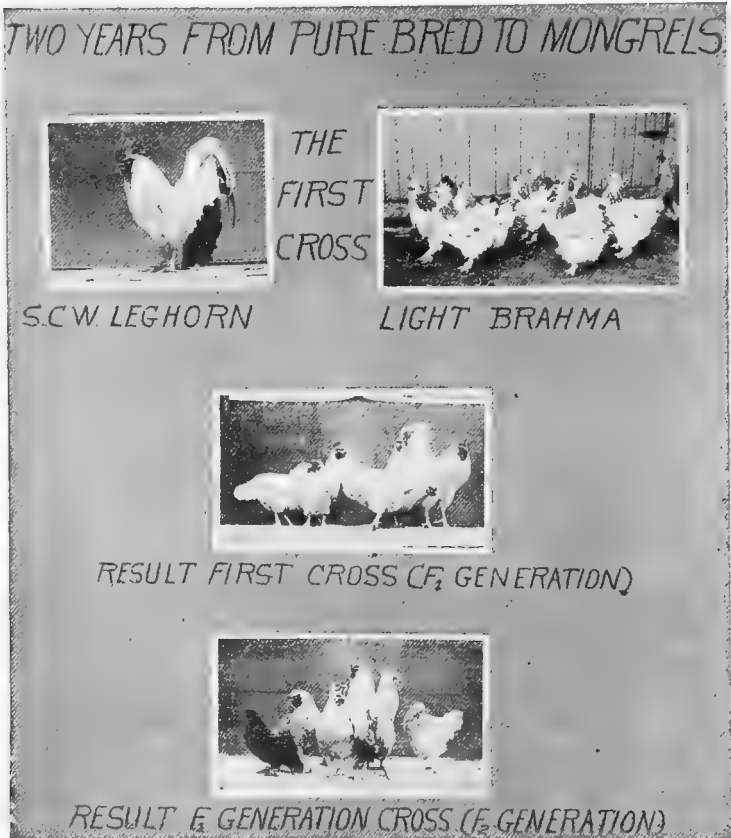

FIG. 51.—Showing the effects of cross breeding and the progeny of the breeding of the cross. (Buss.)

extent the size of the egg; and the comb, an index to sexual development, governs the size of the egg. The Minorca has a large comb and lays a large egg. The Hamburg has a small

comb and lays a small egg. The Brahma has a large body and a small comb and lays a medium egg. As a rule a bird that has a white ear-lobe lays a white egg and those with red ear-lobes lay brown eggs.

Longevity is of the greatest importance, and there is no reason why the average of active breeding, in both males and females, should not be at least five years.

In selecting breeders one should look to the individuality of the bird, its ancestry; that is, it must be from a good strain for the purpose for which it is being bred, whether for egg production, dual purpose, or for meat. The character of the progeny must be taken into consideration; that is, if it has been used for breeding purposes other years.

All hens and male birds should be put off not later than five years of age, and, if forced in laying, the probability is that three years will see their usefulness ended.

As a rule, it may be said that eggs from hens make a greater hatch than those from pullets. Some experiments show 9 per cent. in favor of hens. One- and two-year-old hens are preferable.

That the chicks from hens are a trifle larger than from pullets is shown either by weighing the progeny at hatching or by weighing the eggs at the commencement of sitting. It is impossible to have a baby chick develop larger than the shell it develops in and larger than you have material for it to develop from, and pullet eggs always average smaller than hens' eggs. Chicks from hens are stronger and have a greater constitutional vigor than those from pullets. As a result of these facts, we would expect a greater number of chicks to die coming from pullets as compared to hens.

Records of the ages of birds on the farm can be kept by toe-punch marks; thus, the hatch of 1915 can be marked by means of a punch between the first two outer toes on the left foot, and the next year between the next two toes, and so on. These holes can be punched with a punch made for the purpose or with an ordinary leather punch.

Fig. 52 is an illustration of toe marking, which has often been told and illustrated.

Early Maturing.—The best period of egg production, as indicated before, is the first three years. In many cases the largest yield is during the first year.

Quick growth means less cost of production of eggs as well as of meat.

In rapid-maturing birds egg production comes earlier and is likely to be more persistent. The early layers are usually the heavy layers. As an egg machine the Mediterranean breeds, as the Leghorns and Minorcas, come closer to fitting

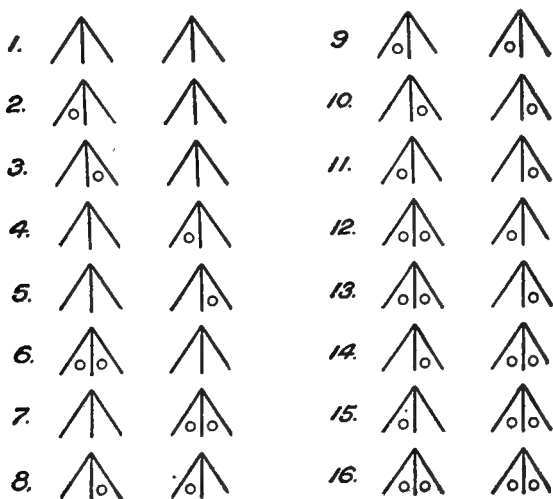

FIG. 52.—How to toe-punch baby chicks for the purpose of identifying them later. Sixteen different lots can be marked without duplication.

the requirements, owing to the fact that they mature early and lay a white egg of good size. Leghorns hatched the first week in April, and properly cared for as to feed and housing as well as to sanitation, begin laying early in the fall, usually when they are about five to five and one-half months old. They will probably not molt till the following fall, whereas if hatched two months earlier they may begin laying in the summer while eggs are cheap and later go into a molt and cease laying for a while.

The larger breeds, as the Rocks, Wyandottes, and Orpingtons, should be hatched about two months earlier than the Leghorns and other light breeds, as it requires about two months longer for them to reach the same degree of maturity.

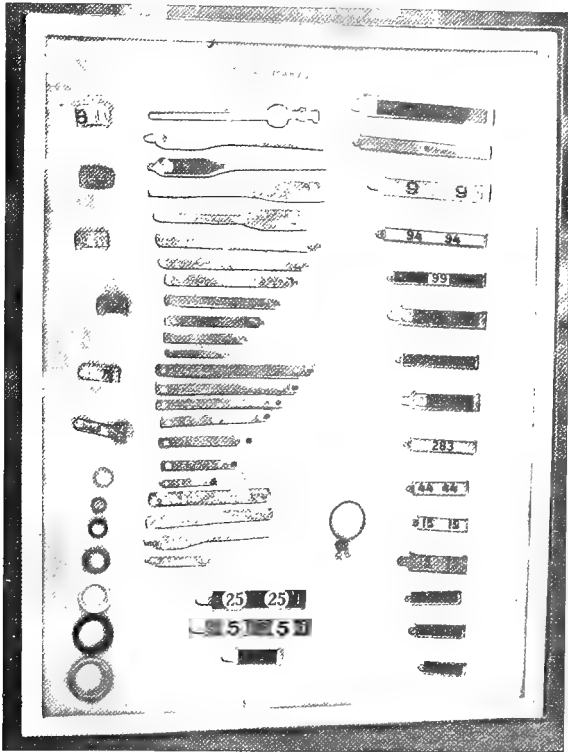

FIG. 53.—A collection of leg-bands. These bands are used where it is the desire to obtain individual records of birds or as an ownership mark. Some are provided with colored celluloid with white rings in which the numbers are black; others are aluminum and are adjustable, others can be sealed, that is, clinched like a rivet, others are celluloid rings. There are different sizes—thus one for Asiatic breeds, American breeds, Mediterranean breeds, pigeons, and baby chicks.

Usually February and March is the best time to hatch the larger breeds and about the first week in April for the lighter breeds.

Some breeders make a practice of mating the cockerels that crow earliest, which they take to indicate early sexual maturity or development and constitutional vigor.

In the lighter breeds that are naturally active, as the Leghorns, Minorcas, and Campines, the male may be mated with a larger number of females than in the breeds that are more sluggish, as the Cochins, Rocks, Wyandottes, and Orpingtons. In the heavier breeds not more than eight or ten hens should be placed with each male, while in the lighter breeds as many as twelve to fifteen hens may compose the pen.

If the hens mated have been running with mongrel cocks, all spermatozoa in the oviducts of the hens should be dead by the 18th day, thus making it safe to save the eggs after that time.

The fertility of the eggs from small and large flocks will reach a level of at least 80 per cent. by the sixth day, and that fertility rate should be maintained throughout the breeding season.

Under ordinary conditions we should obtain a fertility of 80 to 90 per cent., and of those fertile eggs 80 to 90 per cent. should hatch. This is by natural incubation. If artificial incubation be employed, the percentage hatched may be from 15 to 20 per cent. less.

Fertility rapidly declines after the removal of the cocks. It is not advisable to save eggs for hatching after the male birds have been removed from the pens five days.

Cobb says, "Place a male bird among a number of hens, and in a short time you will find him surrounded by the layers and those on the point of laying, and if careful watch is made of his movements, you will observe that he pays special attention to those that are near him. This practice continues throughout the whole season; and as he becomes vigorous, his attentions are confined to the latest to commence to lay, and the older ones are gradually discarded.

"When a cockbird is given all the hens he can care for and kept with them constantly through the summer, fall, and winter, when the breeding season comes he is incapable of properly fertilizing a goodly percentage of the eggs. Therefore the cockbirds should have separate yards and compartments

after the breeding season and to within three weeks before the breeding season when matings should be made.

“The eggs of a pullet are more pointed than those of hens and smaller in size.” The first few pullet eggs are likely to be low in fertility.

The economic importance of broody hens in time lost from laying is indicated by the following table compiled by the Conn. Agri. College.

Breed	Number birds	Number broody, per cent.	Average number times broody	Average days lost per broody period	Average days lost by each broody hen	Average days lost per hen per year
Plymouth Rocks....	129	56—43	2.9	19.3	56	24.3
Wyandottes.....	99	62—63	3.3	18.8	62	38.9
R. I. Reds.....	143	98—69	3.1	18.8	58	39.9
Leghorns.....	345	33—10	1.5	21.6	32	3.1
Miscellaneous.....	100	58—58	3.0	19.7	59	34.3
	816	307—38	2.9	19.2	56	20.9

It is not necessary to have a male bird or birds with the hens out of the breeding season, or those kept solely for egg production. The male bird has no influence whatever on egg production. The male has to do with fertility alone. Experiments have shown that just as many eggs are formed where no male runs with the hens as where male birds are constantly present.

On the farm both breeders and layers should have free range of the fields nine months of the year.

During the breeding season mature hens, preferably one year old or not more than three years old, should be selected and mated with proper males purchased for the purpose and which possess constitutional vigor. These birds should be mated not less than three weeks before eggs are to be saved for sitting purposes.

At the end of the breeding season the male birds may be sold or kept in a separate enclosure and the hens turned out with the balance of the flock.

TURKEYS

In selecting turkeys for breeding purposes one must take those with good-size bone in the shank, heavy weight, mature birds, and they must possess constitutional vigor and breed true to type. The turkey reaches maturity at the age of about three years.

Birds two or three years old are most suited as breeders. Turkey hens give fairly good result when about twelve months of age. The turkey hen begins laying at about ten months of age. There are two laying periods during the year, at spring and at mid-summer. One mating is sufficient to fertilize a whole litter of eggs.

The turkey hen shows that she wants to sit by remaining on the nest a little longer than usual. The nests should be 30 inches square. The nests are prepared on the ground with straw or hay. Sitters should be so placed that they cannot see each other. A barrel turned face toward the wall is a good nesting arrangement. Turkeys like to lay "away" when they are allowed range; they usually make their nests in thickets. On account of the fact that, at times, it is hard to make the hens lay in nests prepared for them, some breeders make a practice of shutting them in a room till noon. Others pen them during the breeding season. Unless the range is large the birds will not receive many kinds of feed, as bugs and green feed, unless these are carried to them in different forms each day.

When a turkey hen is sitting she should always be attended by the same person. The number of eggs laid by a turkey hen will vary from 20 to 50. One large hen can cover as many as 25 eggs. One turkey hen can take care of about 25 poults. Turkeys are very delicate and frail till they are two months old. Cold, rain, dew and hot sun may prove fatal.

The caruncles and fleshy part which surrounds the lower part of the head and throat develop at the age of two months. This is the critical time in the life of the young turkey. During this time they must be kept in a warm, dry, clean place and have wholesome food, including buttermilk and green feed.

Turkeys do not need extensive and expensive housing facilities. The roosts should be put up under a shade tree and should be several feet off the ground. Turkeys roost on the limbs of trees, roofs of low buildings, and fences.

During the day turkeys range over a large territory gathering bugs, worms, fruit, and in the fall acorns. Usually turkeys will come home to roost at about sunset. At this time supplementary feed should be given them in the form of a wet mash or a mixture of equal parts corn, oats, and wheat.

Do not breed birds that are deformed, such as wry tail, crooked toes or legs, crooked back, blindness, lameness, or any defect or deformity likely to be inherited.

It must be remembered that while the turkey breeders aim at large size, yet the popular market demand, which is governed by the demand of the average American family, which is not large in number of members contained in it, is from 9 to 18 pounds. A bird larger than this is too large for the average family.

One tom should be mated to not more than fifteen hens.

A building 40 feet long, 15 feet wide, and 10 feet high will accommodate 40 turkeys.

DUCKS

In selecting ducks for breeding purposes one should take the most vigorous, best shaped, and heaviest birds.

By selecting the largest specimens to breed from the rapidity of growth of the young may be increased. The average weight of the young duck grown for the broiler market, if properly fed and cared for, should be about 6 pounds dressed at the end of eleven weeks.

A drake is considered at his best the first two years of his life, while the duck should be over two years old for breeding purposes. There should be one drake to every four or five ducks.

In determining the duck from the drake in the solid white, one will note that the drake seldom quacks, but has a harsh voice and is usually larger than the ducks. He is a trifle coarser about the head and neck, and has two feathers near the base of the tail which curl up toward the head.

GEESE

In geese the gander may be used the first season, but the geese should not be used for breeders till after they are one year old. Their best breeding ages is from two to five years of age. One gander may be placed with two to three geese.

Geese should be mated early in the winter, not later than the first of February. If mating is too long delayed the females may not lay any fertile eggs during the spring.

When a goose walks around holding straws or bits of wood in its beak, it is a sign that laying time is near. The sitting goose should have grain, green feed, and water.

GUINEA FOWLS

Guinea fowls are natives of Africa. There is no fowl that needs less "given" food than Guineas, or that needs less roosting accommodations.

There are said to be about twelve breeds of Guinea fowls in their native country, but only one has been domesticated in this country. There are three colors of this one breed—namely, pearl, lavender, and white.

Given suitable trees, the old birds will roost in the upper branches out of the way of vermin and are as good as any watch dog to give alarm.

Guinea fowls are monogamous in their wild state, but the cock will successfully mate with two or three hens.

The male birds are usually larger than the females, and have a peculiar habit of strutting about on tiptoe with the back arched. The wattles of the male are more prominent, and are inclined to stick out. The call of the female is much different from that of the male; the call of the male is a more shrill and chattering, a prolonged scream, while that of the female sounds more like "come back!" "come back!" The hens usually begin to lay at the commencement of April and lay continually till the middle of August. The eggs are of medium size, brown in color, spotted with red and pointed. The hens seldom lay in the roosting house, but often select a nest in the open. The eggs should never be removed from the nest

while the birds are in sight, and two or three eggs should always be left in the nest, or the birds will probably seek a new one.

Guinea-hens seldom become broody till late in the season. It is better to hatch early under hens. A medium-sized hen can cover as many as eighteen eggs. The eggs have a strong shell and are seldom broken in incubation. The young are strong on their legs and can run around when only a few hours old. Feed the same as baby chicks.

Guineas are prolific layers and have a tendency to hide their nests in the field. The young are very wild and should be confined in a yard for a while. The Guinea eggs are of good flavor, but small in size. Guinea-hens are not good mothers, as they wander in the wet, dewy grass in the early morning.

PIGEONS

Pigeons breed by pairing off. Only those breeding should be kept in the breeding loft. A separate compartment should be arranged for the balance of the birds.

Racing Homers.—The races consist of distances of 100 to 1000 miles. The old bird races are flown in the spring and the young bird races in the fall. The birds are put through a regular course of training. Then are kept flying around the loft one hour night and morning, besides being taken on numerous short training spins from 15 to 75 miles. This course of training begins about a month before the first regular race is scheduled.

Two lofts exactly alike are maintained. One is used for the race team and the other for the breeders.

Racing pigeons should be fed good sound grain, as much as they will *eat up clean* twice a day. Corn, buckwheat, kaffir corn and Canada peas in equal parts makes a good feed.

The pigeons must be given clean drinking water in such a way that they cannot dirty it. They should have a bath pan set before them every two or three days, but it should be left before them only an hour or so, as they would dirty it and then drink the water.

Squab Raising.—Probably at the present time the improved Homer Carneáux and white King are regarded as the leading

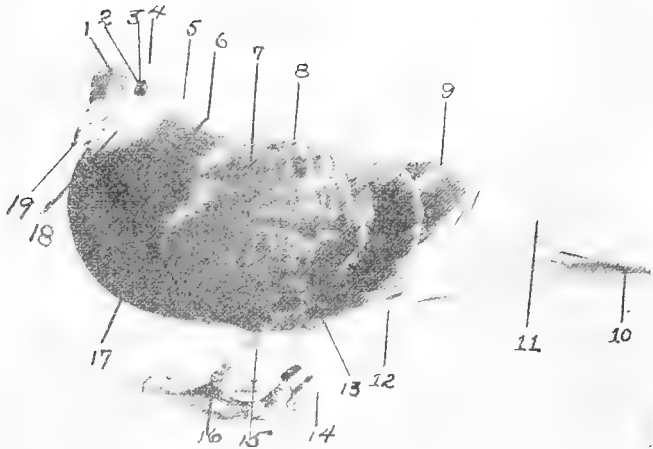

FIG. 54.—A Red-check Gitts hen. Owned by N. C. Exp. Sta. Points of a Homing Pigeon. 1, Top of skull; 2, cere; 3, eye; 4, back of skull; 5, neck; 6, hackle; 7, wing-bow; 8, back; 9, rump; 10, tail; 11, flights; 12, vent; 14, aluminum message holder; 15, leg; 16, feet; 17, breast; 18, throat; 19, beak.

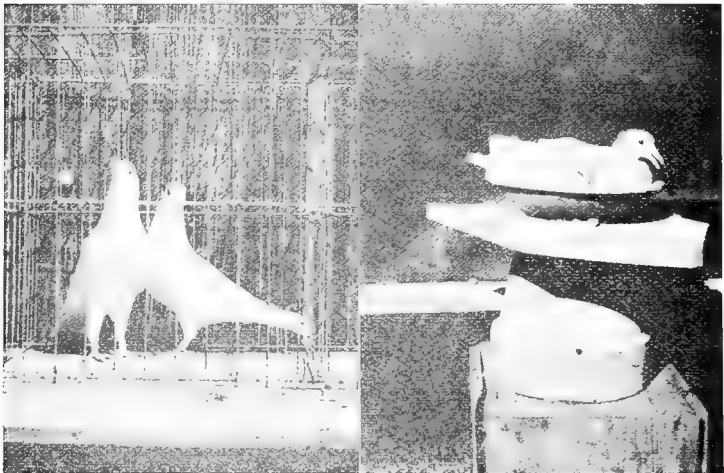

FIG. 55.—A pair of prize-winning White King pigeons and their young. Owned by Mr. Rall.

birds for squab production. They are prolific, hardy, good feeders and mothers, and produces plump, sound squabs.

The Carneaux tends to produce squabs of slightly greater weight than does the Homer.

Crosses of the Carneaux and Homer are being tried out by some breeders with the hope of combining the prolificacy of the homer with the larger size of the Carneaux.

Careful selection of breeders will go far in increasing the size of the squab.

Age of Birds as Affecting Production.—At the age of $2\frac{1}{2}$ to 6 years, the production of squabs is highest per pair of



FIG. 56.—A pigeon loft and fly. Forty to fifty pairs constitute a unit.

breeders. While they will mate and commence breeding at 6 to 7 months and are doing fairly good work at one year, the best years are those mentioned. On the other hand, birds 12 years old have produced 4 pairs of squabs per year, on the average, for a considerable sized flock.

It is fairly safe to figure on 8 to 10 squabs per year for old birds and 11 to 15 for birds from $2\frac{1}{2}$ to 6 years of age.

Housing.—The general principles applying to poultry house construction apply to pigeon houses. The houses should be dry, provide for fresh air, sunlight, air drainage, be sufficiently large to permit the attendant to work conveni-

ently, and give space for the birds. Pens 8 by 8 to 9 feet and 6 feet high, will hold from 40 to 50 pairs.

The side-line squab producer can utilize a small building, an upper floor near a window, or two piano boxes placed together.

The single long house may be of the shed roof type, about 14 feet wide with a 3-foot alleyway at the rear or at the front. If at the front, boxed-in outlets leading over the alleyway are necessary. A door into each pen is an advantage. Both glass and muslin are desirable in the front.

It will be much cheaper and undoubtedly as efficient, to build a wide, gable roof house, 22 feet wide or thereabouts, having a 3-foot alleyway through the center and doors opening into each pen. This type of house should run north and south. The flies should extend away from the building on either side. This should be as wide as the pen and about 24 feet long by 8 feet high. This size is sufficiently large for 50 pairs of birds, is a convenient size for saving waste of lumber, and is low enough to allow ease of catching a bird in the fly. A tread board 6 inches wide is usually placed along the side of the fly.

The roof may be of matched boards covered with paper. The sides and back should be warmly constructed. Foundation walls and floor of concrete are giving excellent satisfaction. The ease of cleaning and the safety from rats and mice make it a very desirable investment.

Interior Fixtures.—Until the plant is sufficiently large to warrant the use of an automatic water supply, the water must be given fresh two or three times per day, depending on weather conditions. Small fountains, self-feeding, with the sides flaring out over the edge of the drinking dish, protect the water from becoming contaminated.

A feed pan or box should be in the pen, as it seems more desirable to feed in a pan or trough than to scatter on the floor.

Bath pans about 2 feet in diameter and 4 inches deep should be provided.

The nests should be simple in construction and easy to clean. The inside dimension of the nest should be about 12 inches square. Two nests are required for each pair as the

birds frequently brood eggs while rearing a pair of squabs in the other nest. A simple method of nest construction is to place a 12-inch board from the floor to the ceiling with one edge against the rear. The 12 inches away on either side place boards 18 inches wide, in a similar way. Cleats may now be placed on these boards the required distance apart up and



FIG. 57.—By having each front painted differently the pigeon always knows his home. The nests should be 12 inches \times 12 inches \times 12 inches.

down. Boards 18 inches long and 12 inches wide, are now cut to slide on these cleats. A strip 12 inches long and 2 inches wide is nailed on the sliding board 6 inches back from the front, which brings it flush with the 12-inch upright board just erected. This method of constructing provides for each pair two nests which are not connected with the

others. When cleaning the slide is pulled out, the nest or manure scraped off, and the slide put back. This proves to be an efficient nest. Nest-bowls may be used. These should not be over 9 inches in diameter. They should be of wood and not earthen ware.

Feeding.—A wide variety of grains may be fed. All of the ration consists of grains, grit, shell, charcoal, and salt, no mash being fed. While it is possible to use several combinations of grains which may give results in the growth of squabs, the following has been found to give satisfaction: Cracked corn, 33 per cent.; red wheat, 25 per cent.; kaffir corn, 25 per cent.; split peas or lentils, 10 per cent.; rice, 5 per cent.; hemp, 1 per cent.; and millet, 1 per cent. This ration is varied according to the prices; and peanuts, hulled oats, buckwheat, barley, rape, vetch, and about any kind of grain, may be used. White wheat is not considered as good as red wheat.

Other rations for pigeons:

Cracked corn.....	45 parts
Wheat.....	45 parts
Canada peas.....	10 parts
Total.....	100 parts

Cracked corn.....	45 parts
Wheat.....	45 parts
Cracked peanuts.....	10 parts
Total.....	100 parts

Cracked corn.....	25 parts
Kaffir corn.....	25 parts
Wheat.....	25 parts
Bread crumbs.....	25 parts
Total.....	100 parts

Wheat.....	40 parts
Hemp seed.....	10 parts
Cracked corn.....	10 parts
Buckwheat.....	10 parts
Kaffir corn.....	10 parts
Canada peas.....	10 parts
Millet seed.....	10 parts
Total.....	100 parts

The grain is fed in the morning and afternoon, and enough given so that it is about cleaned up in $1\frac{1}{2}$ to 2 hours. Only clean, wholesome grain should be fed. Small hoppers of grit, charcoal, oyster shell, and salt are provided. Some breeders use a health grit, which is a mixture of shell, grit, salt, and other substances, and which is much relished by the pigeons.

Special care must be paid to the feeding as the old birds go directly to their young and food is transferred from the crop of the old bird to that of the squab, through the mouths. For the best results, it is necessary that sufficient feed be given at regular feeding periods.

Pen Management. Pairs per Pen.—About 50 pairs per pen seem to be a good working unit.

Nest Material.—A slatted frame with removable top may be placed against the side of the building. This should be kept filled with cut straw 8 inches in length. The mixture should be about half and half. The birds make their own nests.

Selecting Breeders.—It is not a good policy to select the largest bird from a pair to save as breeders, as by so doing, a larger percentage of males is likely to result. A better way is to save only from those nests which contain two large, well developed squabs. By selecting for size, shape, and strength, any breeder can improve the type of market squabs. Plumage color may also be a factor, although some pigeons, as *e.g.* the Homer, come in many different colors.

Mating.—As these squabs are selected, they are banded with an aluminum band and placed in a pen along with other youngsters. Here they continue their development and eventually mate and breed. Careful watching should be kept and when a nest with eggs is discovered, the birds should be trapped. The male bird broods the eggs from 10 A.M. to 4 or 5 P.M., and the female the rest of the time. Making use of this fact, the breeder is able to determine the sex. When a bird is caught it is banded with a colored band, the male on one leg and the female on the other. It is but rarely that brother and sister mate, as they are in a pen with 50 other unmated pairs. The aluminum band placed on at the time they were selected shows whether they are related or not.

In case it is found that this sort of mating has occurred, they are placed in different pens and mated again. Inbreeding is not desirable.

Pigeons as a rule are monogamous, and are faithful to each other until death. It is this fact which makes it possible to keep so many pairs in a pen and have them work successfully. Occasionally a bird will be untrue and cause a great deal of trouble in the pen. This bird should be removed and either disposed of or forced mating applied to.

Forced mating consists in placing a male and female in a coop with a wire partition between, and leaving them there for from 6 to 10 days, then letting them go together. If they appear properly mated they may be placed in the breeding pen.

Banding.—Colored leg-bands show at a glance the mated pairs in a pen and are convenient in many ways. For a pen of 50 pairs, 50 color combinations are used, each mated pair wearing a certain color, the male on one leg and the female on the other. It is a simple matter to enter a pen and pick out a mated pair when banded in this way.

Records.—If it is desired to know the color markings of a pair, a sheet may be ruled off for each pen, males on one side and females in the corresponding space on the other. A key of letters showing the color markings may be made, and as a pair are mated and put in their permanent pen, their band colors and key letter showing the color is entered in the respective space on the sheet. If at some future time there is a prospective sale of a pair of a certain color, the chart will give the color of each bird in the pen and save considerable time.

Baths.—Baths should be given at least three times per week in summer and on warm days in winter. The bath pans are filled and left for an hour, during which time the pigeons bathe themselves. The bath is essential for maintaining the health of the birds. If the flics can be constructed over running water, the labor of preparing the bath and emptying the pans may be dispensed with.

Cleaning.—The old nests should be removed at weekly intervals. Any wide, flat piece of metal with a handle is very

efficient in scraping the type of nests previously mentioned. The floors should be cleaned monthly.

Killing, Cooling, Packing, and Shipping.—The period of incubation of pigeon eggs is about 17 days, and the squabs are ready for market at about 4 weeks of age. When the body feathers under the wings are just past the pin feather stage, squabs are ready to kill. At this time they have no pin feathers and pick easily. If they are left a few days longer, they will be flying, which is not desirable. Squabs should be collected in the morning before feeding the old birds, as this insures empty crops and leaves them in better condition for killing. From 18 to 22 squabs may be dry picked in an hour. The feet are slipped into a wire which is bent to hold their legs apart. The neck may be held by one finger while picking. As this is likely to prevent free bleeding, a better method is to fix a small can with a sharp prong on the inside of the can over which the beak is hooked. This stretches the neck out, holds the squab, and the can catches the blood. Free bleeding and clean picking is desired by marketmen. White-skinned squabs are worth more on the market than those with dark skin.

A killing room is desirable where much killing is to be done. A cement floor which can be cleaned readily, and removable cans, boxes, and shelves for holding the squabs, are important.

After the squabs are picked they may be hung in a cool place or placed in cold water to cool.

Squabs may be shipped in egg cases or other carriers. An egg case will hold 10 dozen squabs without ice. During warm weather a layer of ice (cracked) is placed on the bottom, then a layer of squabs, followed by more ice and squabs. Barrels are used with good results.

Express shipments should be made. Special rates may be obtained in certain cases from express companies on squab shipments.

Prices of Breeders and Market Squabs.—Prices for breeders usually run from \$1.75 to \$2.25 per pair according to age.

Marketmen like a heavy squab, and the prices vary from 50 to 75 cents for culls to \$5.50 or \$6.00 per dozen for 10 and 12 lb. squabs. Prices are usually sent weekly by the commission men to those having squabs for sale, if requested. Business

is conducted on a 5 per cent. commission basis. Prices are quoted on 6, 7, 8, 9, 10, 11, and 12 lb. squabs.

The live poultry markets usually furnish a better market for the squabs of inferior quality.

Live pigeons are shipped in baskets or in crates, with self-feeders and water cups attached, and a supply of feed sufficient to last the birds the entire trip. With this arrangement birds can be shipped any distance and arrive at their destination in first-class condition.

CHAPTER V
HYGIENE AND SANITATION

WATER

RAIN is the original source of all water. The water from wells, deep and shallow, springs, and rivers all come from the clouds.

When rain descends it drains from the watersheds to brooks, which make rivers, or percolates through the ground, or evaporates.

The amount of water that will percolate through soil depends on the porosity of that soil, and upon the slope of the ground as well as the time of year.

The amount of water that evaporates from the surface of the soil depends on the time of year and the temperature of the atmosphere. A dry, warm air absorbs water from moist surfaces rather rapidly.

Percolation occurs more rapidly in sand and gravel, where the percentage may run as high as 90 per cent. of the rainfall upon it.

Red sandstone may absorb or percolate 25 per cent., while magnesium limestone may percolate as much as 20 per cent.

Water which percolates through the soil again returns to the surface by wells and springs.

As the water percolates through the soil and follows the cracks and fissures of the rock it absorbs carbon dioxide gas from the air, which aids in its erosive and soluble action in dissolving mineral matter.

The original water as it reaches the earth is free of any mineral matter, and is termed "soft water." After reaching the earth the absorption of considerable lime-salts causes the so-called "hard water."

Springs are surface outlets of underground water. The

amount of water coming from such a spring depends on the rainfall and upon the collecting area.

An inch of rain delivers a little over $4\frac{1}{2}$ gallons on the square yard surface, which is 101 tons on each square acre.

In falling during rainfall the water absorbs the impurities of the air which, in certain manufacturing communities, may be nitrous or nitric acid, ammonia salts, sulphurous acid, and products of combustion of coal and other combustive products used in generating power.

The first rain that falls contains more of these products or impurities as well as bacteria.

Water collected in large lakes or reservoirs or ponds is attacked with vegetable growth on account of the organic matter contained in the water, which organic matter has been gathered from the watershed during the rain and drainage.

The vegetable growth appears as a green scum. Most vegetable matter of this kind is not poisonous, though in India a poisonous kind has been found.

Vegetable growth has a tendency to purify the water, as it utilizes the organic matter the water contains.

River water usually contains more impurities than pond water. It is common practice for cities and private individuals to empty sewage and to dispose of other waste matter by aid of the rivers.

Often rivers are polluted with germs of disease and form one means of spread of contagious diseases.

Wells are classified as shallow, deep, and artesian. These form a source of pure water-supply, provided they have not become polluted through soil seepage.

One of the sources of pollution of shallow wells and springs is cesspools and barnyards, as well as outdoor privies.

The impurities found in water are of two kinds—namely, inorganic and organic. The inorganic impurities are the salts of metals. Inorganic material may gain entrance into the water by passing through pipes, canals, from river beds, from watersheds, from irrigation ditches, and by percolation through soil and over rock.

The inorganic impurities depend upon the geologic formation.

The organic impurities are animal and vegetable substances. Water will be so contaminated if it comes in contact with animal excreta or animal refuse of any kind, including dead animals and bowel discharges.

In percolating through the soil the earth acts as a filter and there is a tendency to purify polluted water. There is a constant oxidation, by aid of germs, of all kinds of organic matter on and in the soil.

Water from cultivated lands is usually very impure on account of the large amount of organic matter gathered from it.

Certain diseases are said to be water-born, that is, the germs causing the disease gain entrance into the water, and fowls drinking the polluted water may become inoculated and contract the disease. A bird may die of cholera and be thrown into the stream or close to the stream, so that seepage in time of rain may carry the contagium into the water and thus form a source of danger; or drainage from a yard containing infected droppings from birds with cholera or other contagious bowel diseases may find its way into the stream, and this contaminated water may pass for miles down country and other fowls consuming the germ-laden water may contract the disease.

As a rule, it is considered that germs of disease do not live indefinitely in the water, but after a while die.

Puddles of polluted water in the barynard or hen yard may contain embryo of intestinal worms or harmful germs. Moist places are favorable locations for the preservation of the embryonic worm outside the body, awaiting a time to be taken up by a susceptible bird.

AIR

Pure air is of the utmost importance to successful incubation brooding, and to any class or age of birds. While the bird may do without water and food for hours, or even a day, it must have a constant supply of fresh air. Polluted air soon makes an alarming change in the organism. Since the living processes are going on in the animal body every minute, and even every second, it must be remembered that this means a

constant tearing down and building up, which means a constant supply of oxygen from the air by way of the lungs and the circulation and a return of a poisonous gas, carbon dioxide, by the reverse route, lest the bird dies of oxygen starvation and carbon dioxide poisoning.

The body then is a great oxidizing apparatus and must have a constant and abundant supply; hence ample ventilation of all types of poultry houses is imperative.

Air is a mechanical mixture of three gases—namely, oxygen, nitrogen, and carbon dioxide, with traces of other gases, as ozone, ammonia, argon, and bacteria, and other impurities that chance to be floating in the air. The usual accepted formula of air is as follows:

Nitrogen	78.00	per cent.
Oxygen.....	20.96	“
Argon.....	1.00	“
Carbon dioxide.....	.04	“
	<hr/>	
	100.00	“

Air has a tendency to be purified by washing in time of rain.

Plants utilize the carbon dioxide from the air as plant food and is used in the construction or building up of starch in the plant, and in return the plant gives off to the air oxygen as a by-product in this starch construction.

Since oxygen supports combustion in the body it is a constant and essential element.

When the air contains as great an amount of carbon dioxide as 5 to 10 per cent. it becomes poisonous, hence ill effects in improperly ventilated brooder houses and incubator rooms, as well as rooms for other kind of birds.

The earth contains two hundred and fifty times more carbon dioxide gas than the atmosphere.

During dry, dusty, and windy times there may be considerable organic and inorganic matter in the atmosphere. These dust particles contain germs, some of which may be germs of disease, and this is one way contagious diseases are spread. The infected dirt particles are blown from an infected yard to other premises by the wind.

To summarize, the impurities of the air may come from the respiration products of man and animals, by decomposition of organic matter, by various offensive trades, as copper smelting, alkali works, smelters, and by combustion of gas, coal, and artificial lights.

COMPOSITION OF EXPIRED AIR

	N	O	CO ₂
Expired air	79.01	16.02	4.38

RESPIRATION

The organs of respiration in the fowl are the nasal passage, larynx, trachea, lungs, and air-sacs.

The lungs occupy the thoracic or chest cavity, pushing out between the ribs, leaving only a thin muscular wall between them and the skin.

The process by which the lungs are filled with air is known as inspiration. The process by which the air is forced out of the lungs is called expiration.

The fowl is provided with six air-sacs, as follows: two at the anterior portion of the thorax, two at the posterior border of the same, and two rather long and large sacs, called the abdominal air-sacs, which lie along either side of the abdominal cavity. These communicate with the lungs. In addition to these, in the birds of flight there are air spaces in the larger bones, as the femur and humerus.

Before the air reaches the lungs it is normally warmed by passing through the nasal cavities, but air may pass through the mouth into the lungs; thus, in excessive body temperature as in hot weather the body temperature is lowered by the bird holding its wings out from the body to give a chance of greater cooling surface (the action of the atmospheric air against the skin capillaries), and by opening the mouth, and by rather short, quick pants, which rapidly changes the air in the lungs, thus through the watery vapor and cooling the temperature is lowered. In this latter process the air is not warmed by the nasal passage before entering the trachea to the lungs. The anterior nares are small and are immovable, hence the volume of air cannot be increased through that channel. The nasal

chamber is divided into two parts by the turbinated bones, which are very thin and rolled like a coil of paper.

It is probable that the sinuses of the head (infra-orbital and nasal) furnish a large mucous area which warms the air to a certain extent before passing into the long trachea (windpipe).

There are certain changes that take place in the air that passes into the lungs. It was seen from the above discussion of air that it consisted of 20.96 volumes of oxygen, 78.00 volumes of nitrogen, 1.0 volume argon, and about 0.04 volume of carbon dioxid.

The carbon dioxid, as shown before, is an impurity in the air. It is essential to plant life, but poisonous to animal life when in concentrated quantities.

The air is spoken of as dry or saturated, depending upon the amount of watery vapor it contains.

Dry air contains about $\frac{1}{4}$ of 1 per cent. watery vapor.

When air passes into the lungs oxygen is absorbed from it by the capillaries of the air tubules. In return for this there is given off to the atmosphere carbon dioxid, a by-product of combustion in the body.

The volume of carbon dioxid given off is slightly less than the amount of oxygen absorbed.

Expired air is warmer than inspired air and is saturated with watery vapor.

The blood is composed of plasma, an unorganized body or liquid in which floats the organized constituents of the blood. In the fowl these organized bodies or cells are the red blood-cells, the thrombocytes, and several types of white blood-cells.

The oxygen from the inspired air is absorbed through the wet membrane, the capillary wall, into the blood-plasma, from whence it is absorbed by the hemoglobin of the red blood-cells.

The oxygen forms a loose chemical union with the hemoglobin, in which form it is known as oxyhemoglobin. In this form, through the blood-vessels, the cells laden with oxygen are carried to all tissues of the body, where through the single-layered cell capillary wall oxygen is given off to the cells of the tissues through the laws of diffusion of gases, thus the oxygen is enabled to support combustion in the body. A forced cessa-

tion in respiration means immediate oxygen starvation and death. It is a continuous process, never ceasing a minute or second till death of the bird. Such cessation and death by shutting off the air-supply is called asphyxiation.

The pressure of the carbon dioxide is lower in the systemic capillaries than in the tissues, and the result is that there is a constant diffusion through the capillary walls into the blood-plasma, as the carbon dioxide is formed in the tissues through combustion processes. The carbon dioxide thus passing into the blood-plasma is carried to the lungs, where the venous capillaries which are spread out, forming a network on the surface of the lung tubules, allows it to diffuse through into the air and is gotten rid of from the body.

It is possible that the sodium carbonate of the blood unites with the carbon dioxide in the blood-plasma, thus aiding in its transportation.

When birds are shut in a close coop or room, that is, one without proper ventilation, so that there may be a proper exchange of fresh air for the birds in the room, they will breathe the air over and over again, and there is a gradual loss of oxygen and an increase in the carbon dioxide content.

If the amount of oxygen falls from 20 per cent., the amount normally in the air, to 11 per cent. there is noted distressed breathing, and when it falls to 4 per cent. there is rapid asphyxiation and death.

Respiration is presided over by the nervous system. The respiratory nerve-center is located in the floor of the fourth ventricle in the medulla oblongata (at the base of the brain).

Excessive bodily temperature or exertion causes accelerated respiration. The fright caused in handling birds is sufficient in most instances to more than double the number of respirations.

VENTILATION

The object of ventilation is to supply pure air to the lungs, to dilute and remove from the hen house the noxious gases off from the lungs and from the fluidy portions of the excreta or droppings evacuated from the bowels.

It is not considered ventilation if the incoming air is derived

from a contaminated source. It is essential that pure air be supplied.

In ventilation we have three factors to consider—namely:

1. The amount of fresh air required.
2. The method by which fresh air can be supplied.
3. The method of examining to determine whether ventilation be sufficient.

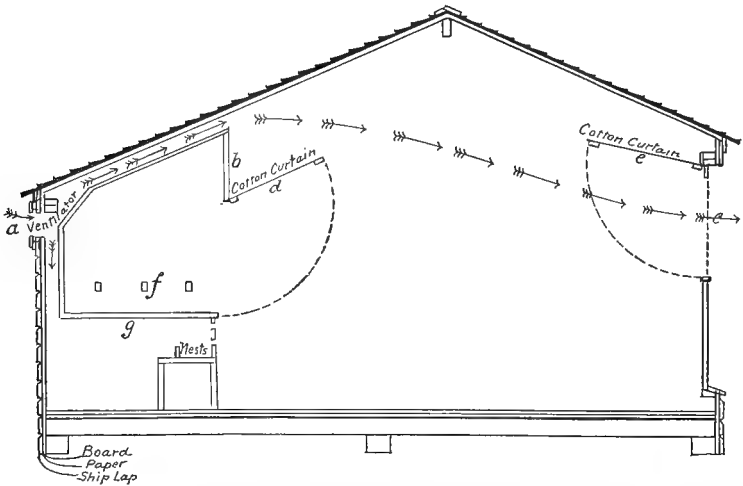

FIG. 58.—Diagram showing currents of air through a poultry house. The air entering at *a* passes under the dropping board and above the dropping board at *b* and *g*, but no draft strikes the birds on the roosts at *f*. The air passes through the house as indicated by the arrows and out at *c*. For cold climates it is desirable to have a front drop curtain immediately in front of the birds and at the front of the house, as indicated in the drawing. The curtain material must allow of the passage of air through it.

The amount of fresh air required by average size fowls is 8278 cubic feet per thousand pounds live weight each twenty-four hours.

Russel estimates that an average sized fowl breathes about 1.2 cubic feet of air per hour or one foot per minute. Each bird should be provided with ten cubic feet air space. Geese and turkeys should have 40 cubic feet per bird.

There is a method whereby a physical test may be made to fairly accurately arrive at the amount of carbon dioxid that is

present in the air. The test is as follows: The sense of smell is immediately recorded upon entering a building from the outside. If no sensible difference in smell can be determined,

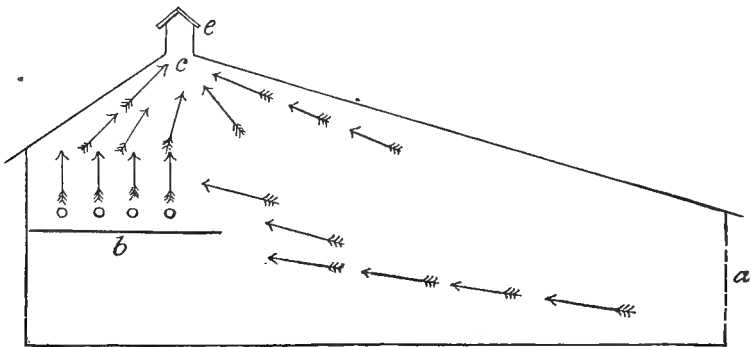

FIG. 59.—If a house be constructed as indicated the vitiated air would rise at the highest point in the house, which is at *c*, and unless provided with a ventilator would stagnate there. With the ventilator the air enters the house at *a* (an open front), passes backward over the roosts at *b*, and takes an upward course and out the ventilator at *e*.

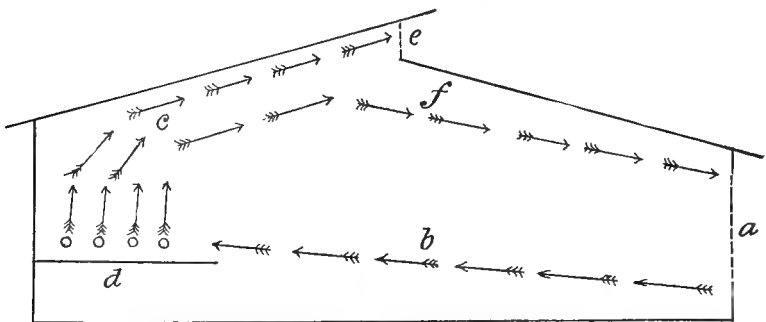

FIG. 60.—The half monitor is a good building from a hygienic standpoint. The air enters the open front at *a* and passes backward to the roosts at *d*, and the vitiated air being lighter rises and passes out at *e*, and some currents, taking the course indicated by *f*, pass out the upper part of the open front at *a*.

the inside air smelling as fresh as that outside, the amount of organic matter is at its lowest point, and such air is given on analyses 0.6 per thousand or per cent. carbonic acid; that is,

0.2 per thousand added to the already 0.4 normally existing in the air. It has been determined that the greatest amount of carbonic acid that can exist in the air without impairing the "freshness" is 0.2 per thousand. If the air smells rather close of respiratory impurities it is 0.4 per thousand. If the air is close then the impurities are recorded as 0.6 per thousand. If very close, that is, offensive, the carbonic acid present is



FIG. 61.—A small open front colony house. Plenty of fresh air is essential in successful poultry culture.

recorded as 0.9 per thousand. The smell cannot differentiate beyond this degree.

A poultry house should be ventilated so that it will not have more than 0.2 per thousand. One difficulty in carrying out this test is the odor of ammonia and other products originating from the droppings.

Fresh air may be supplied in two ways—namely:

1. The process of diffusion.

2. The action of the winds.

In the process of diffusion the various gases present in the building mix. This process is slow. It may mix by diffusion through more or less porous walls or by cracks. The latter is extremely dangerous should the draft be directed over the roosts and strike the roosting birds.

Winds are a great natural power of ventilation. The wind sets the masses of air in motion, and is a means of flushing and renewing the air in the buildings. Wind blowing 3 miles an

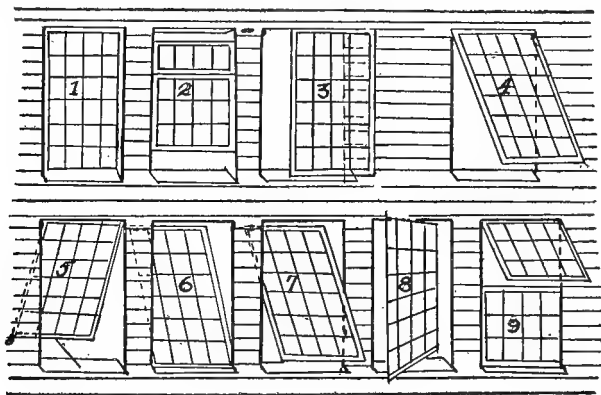

FIG. 62.—Methods of hanging windows. 1, Swings from the side; 2, the sash may be raised or lowered; 3, slides to one side; 4, swings in from the top; 5, swings out from the bottom; 6, swings out at the top; 7, swings from pivots in the center; 8, swings from pivots from the ends; 9, upper half sash swings out from hinges above.

hour (which is a little more than is perceptible) through a ventilator 1 foot square in size will force the passage of 15,840 cubic feet of air in one hour time. Thus, through such a ventilation in a space of 1000 cubic feet the carbon dioxide content of the air may be reduced from 0.6 per thousand to 0.1 per thousand. The objection to using wind as a ventilating agent is that the velocity may mean a draft.

In supplying heat to brooders and in their ventilating problems the fact that heated air becomes light and rises must be kept in mind, thus the monitor and half monitor houses fur-

nish ideal conditions for the escape of the light vitiated air arising from the birds, while the cooler outside air comes in at a lower level, causing an upward current, relieving the building of polluted air by the process of diffusion and air currents.

Air shafts or tubes may be used, and can be used as either inlets from the sides or outlets from the top or roof. Air passing along a tube suffers loss from friction; thus, air moving through a tube at a velocity of 8 feet per second would be reduced to 4 feet per second on striking a right angle. The



FIG. 63.—Methods of hanging doors. 1, The upper half swings out; 2, the door swings both ways on a two-way hinge; 3, each half swings out; 4, the door swings out; 5, the door slides to one side on a track.

smaller the tube, the greater the friction and the greater interference with the velocity per volume of air. Tubes should be made with rounded or U-shaped curves instead of abrupt straight right angles.

One foot square will admit 15,000 cubic feet of air per hour with a calm air; that is, with the velocity of 3 miles per hour. Light air, that is, 8 miles per hour velocity, 0.4 square foot will admit 15,000 cubic feet of air per hour. A light breeze, or 13 miles an hour, 0.2 square feet will admit 15,000 cubic feet of air per hour.

CHAPTER VI

THE CONSTRUCTION OF POULTRY HOUSES

SOME of the essential features is the economic construction of the houses, to provide sufficient room, proper ventilation, proper equipment, and durability.

As a rule, the old farm buildings can be utilized, using the principles here laid down, and thus making a saving and at the same time meet every necessity.



FIG. 64.—A group of model houses constructed by the students of the Poultry Science Department, A. and M. College, W. Raleigh, N. C. This work is done in the laboratory of the mechanical department: *a*, Monitor type; *b*, a half monitor; *c*, even span; *d*, two-thirds span; *e*, shed roof.

The construction of proper flooring, drainage, and foundation are the first essentials. Heavy sills of good material are essential. Number 2 pine siding may be used for boarding up the back and two ends. The roof should be covered with boxing boards and then with a good grade of tar paper.

Where winds cause trouble in tearing off the rubberoid by getting underneath it, the boxing boards should be replaced by tongued and grooved flooring and the edges of the roofing paper or rubberoid brought over the edge and securely nailed using strips of tin made for the purpose.

The back and two ends are thus made tight, leaving the properly constructed open front, as illustrated in Fig. 61. In constructing the interior the labor-saving devices should be provided. By referring to Figs. 68 and 72, which are reproductions of blue prints of the North Carolina Experiment Station, these devices are seen to consist of drinking vessels

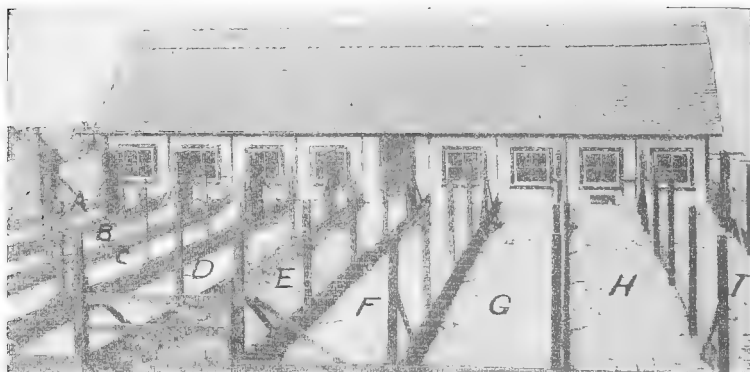

FIG. 65.—A unit system house and yard: A, B, C, D, F, G, H, I represent separate runs for the separate compartments; E is an alleyway.

which are quickly and easily cleaned, a mash hopper of sufficient capacity to carry sufficient mash to last the flock a week, hopper compartments for grit, charcoal and oyster-shells, nests properly constructed, roosts and dropping boards constructed according to instructions. The open front ensures sunlight, which in warm climates can be left open all the year and in cold climates may be protected with a muslin curtain or drop sash during the cold spells. It is essential that the floor be free from moisture, as a cold, wet floor means unthrifty flocks, and thus unprofitable. In a house where the floor is noted to be wet it will also be found that there is water of con-

densation—that is, drops of water has formed on the walls and equipment, which makes an unhealthy condition. With a dry floor and plenty of head room and ventilation there will be a dry condition, and the water of condensation will not be noted. In cold countries, by the substitution of muslin for the glass windows, it will be found that with other conditions being correct there will be no water of condensation form and the building will be dry.



FIG. 66.—A partial view of a poultry plant, showing at *a* a half monitor house; *b*, two-thirds span house; *c*, a shed roof house; *d*, an outdoor dry mash hopper.

As stated before, good ventilation is essential and that there be no drafts on the birds. Birds contract colds if they are in the draft, and a bird with a cold will not produce eggs. Plenty of fresh air is essential to health of the birds. Proper ventilation so as to ensure an exchange of air. Pure air means plenty of oxygen, and foul air means a lack of the proper amount of oxygen and an excessive amount of carbon dioxide or poisonous gas that must not be allowed to accumulate. In Figs. 58, 59, and 60 will be seen illustrated three principles of ventilation.

The laying hen must have exercise. Exercise is essential to good health and egg production, as well as for fertility. By a study of the blue-print sketch, it will be seen that the entire floor of the buildings is to be used for scratch room, and that it is planned to provide 4 square feet of floor space for each hen. The compartments in Fig. 68 are 20 by 20, which will give a floor space of 400 square feet or room for 100 birds.

It must not be overlooked that it is essential to make the house as nearly rat-proof as possible. Rat-proof floor con-



FIG. 67.—A partial view of colony house poultry plant, with a group of students in poultry science in the foreground.

structed of concrete is the best. Rats sometimes cause death of the pullets and consume large quantities of mash, unless the mash hopper be provided with a proper drop door and kept closed during the night. The amount of mash a family of rats will eat will amount to quite a number of dollars in the course of a month.

The internal construction of the house should be as plain as possible, so as to allow of as little chance of the harboring of filth and vermin as possible. By simple construction the

NORTH CAROLINA
 AGRICULTURAL EXPERIMENT STATION
 WEST RALEIGH N.C.
 POULTRY DEPARTMENT
 Open Front, Intensive, Multiple Unit
 Laying House

Unit Capacity 20x20 =
 100 Birds
 Both units 200 Birds
 If only 100 Birds are kept
 Build only One unit
 Approximate Cost of
 Material for Double
 Unit = 180⁰⁰

Floor Plan

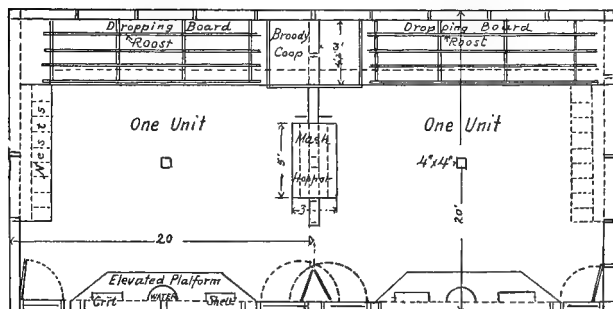

Cross Section.

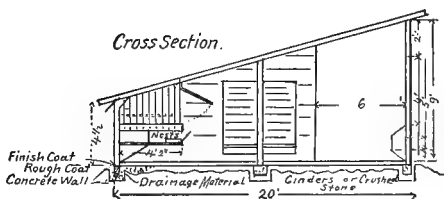

Front View.

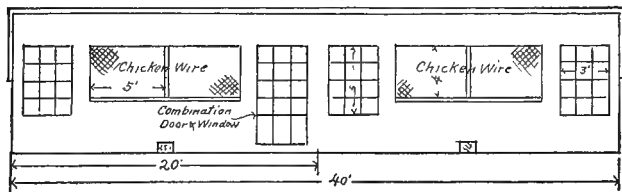

Fig. 68.—Photograph of blue print from the North Carolina Exp. Station. This is a double unit system house, each unit accommodating 100 birds.

buildings may be kept clean. All fixtures, dropping boards, roosts, nests, and other equipment should be made movable so that they can be taken out and thoroughly cleaned and disinfected and rendered free from vermin.

Figure 68 is a plan for a double unit system house. A similar house was first designed and advocated by Prof. H. R. Lewis, of New Jersey Experiment Station; blue prints of this are furnished the residents of North Carolina, together with bill of lumber, to assist them in constructing suitable houses for that mild climate. The house is 40 feet long and 20 feet wide (outside dimensions). The sills are to be of yellow pine,

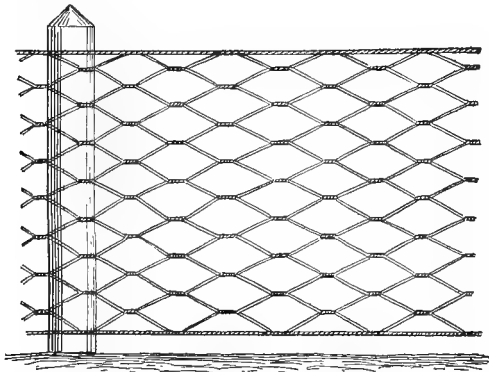

FIG. 69.—Six-sided mesh poultry wire. This is a poor netting, and to hold it in shape in the fence it is necessary to make a frame for it so that it is possible to staple it on all four sides of the panels.

4 by 6 inches, and to be bolted to a concrete foundation, 4 inches wide and 24 inches deep. This wall is laid in tamped crushed rock or cinders, the entire foundation trench being 3 feet deep. This allows of good drainage and prevents the floor from being wet. The entire floor-surface consists of 10 to 12 inches of tamped crushed rock or cinders and 3 to 4 inches of cement. The cement should be of smooth finish, using a mixture of 1 part Portland cement to 2 parts sand for the finish coat and 1 to 7 for the balance. It will be noted that the roof is of the shed type, which is one of the cheapest

types to construct. The front studding is 9 feet long and the rear studding $4\frac{1}{2}$ feet. The rafters, like the other framework, may be made of yellow pine. A 2 by 6 girder extends the whole length of the building, the rafters resting on this girder; 4 by 4 posts support this girder, the same being placed every 4 feet. These posts are set on concrete piers. The ends, sides, and roof should be boarded up with 6-inch tonged and grooved yellow pine. It is customary in cold countries to cover the back with roofing paper. The top is to be covered with good tar roofing paper. All paper joints must be carefully lapped and cemented.

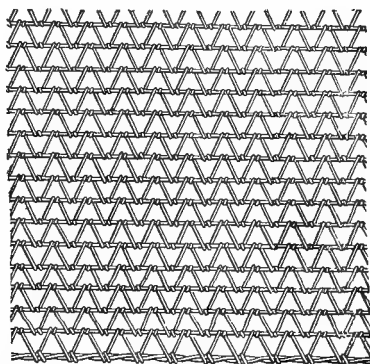

FIG. 70.—Three-sided mesh poultry wire, which is an improvement over the six-sided mesh.

The muslin curtains in the front wall are hinged at the top and can be lifted up and hooked at the top till stormy or intensely cold weather, when it can be let down. In order that there be an abundance of light at these times 3 by 5 feet glass sash are placed in the front. In warm climates, where it is not essential to have muslin curtains, the expense of these windows can be saved by not constructing them.

It will be noted that the dropping boards and roosts are at the extreme back, which takes the birds back into the recess and ensures that they are not in a draft which would be injurious to their health. The nests can be so constructed that the front, in which the hen enters, is rather hidden, and a trap

door arranged on the exposed side from which the eggs may be gathered.

The dividing partition may be of either substantially strong wire or of a solid partition. If of solid partition, it should extend from the back wall to within 6 feet of the front wall. In this space there is constructed a wire partition, a part of which is made into a door between the compartments so that one may enter the other compartment without going outside. In the front the windows in each compartment can be made into a combination door and window, as illustrated.

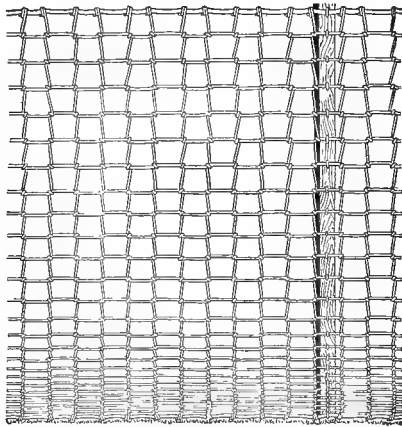
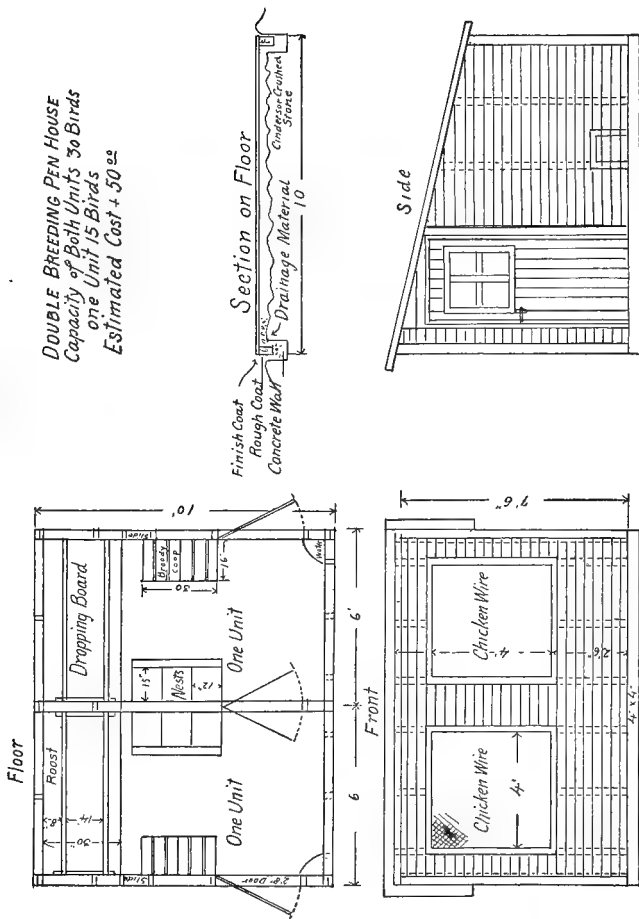

FIG. 71.—The rectangular mesh wire and the best adapted for poultry fences.

The floor should be constructed as follows: (1) Lay 10 inches of cinders or crushed rock and tamp in well. This provides drainage and keeps the wet away from the top of the floor. (2) Place 4 inches of rough concrete, making about one-seventh cement. (3) Place on a finish coat made up of one part cement and two parts sand. Trowel out smooth and make rat-proof at all points.

The following is a list of the materials needed to construct the 40 by 20 double unit system house.

NORTH CAROLINA
 AGRICULTURAL EXPERIMENT STATION
 POULTRY DEPARTMENT
 WEST RALEIGH, N.C.



DOUBLE BREEDING PEN HOUSE
 Capacity of Both Units 30 Birds
 one Unit 15 Birds
 Estimated Cost + 50.00

Fig. 72.—Photograph of a blue print from the North Carolina Exp. Station. This is a double unit system house; each unit will accommodate from 15 to 25 birds.

LIST OF MATERIALS FOR THE 40 BY 20 FOOT HOUSE

Double Unit House.....	Capacity, 200 birds
Sills.....	6 pieces 4 × 6—20 ft.
Plates.....	8 “ 2 × 4—20 ft.
Posts.....	{ 2 “ 4 × 4—14 ft.
	{ 9 “ 4 × 4—18 ft.
Studding.....	{ 2 “ 2 × 4—18 ft.
	{ 4 “ 2 × 4—14 ft.
Rafters.....	21 “ 2 × 4—22 ft.
Frame for nests and dropping boards, 5 pieces, 2 × 3—16 ft.	
8-inch grooved yellow pine boards for roof, dropping boards, walls, and nests, 2200 sq. ft.	
1 × 2 white pine for curtain frames and trim, 200 linear feet.	
1 × 4 white pine for nests, 100 linear feet.	
One bundle plaster lath for broody coop.	
Nails: 10 lbs. 20-penny nails; 50 lbs. 10-penny wire; 20 lbs. 8-penny nails.	

If it is the desire to keep only 100 birds then build only one unit.

There is another convenient plan for house construction, where it is the desire to keep only about 30 birds or two breeding pens of about 15 birds each. Figure 72 illustrates this plan.

The bill of lumber is as follows:

All framing material hemlock or yellow pine.

Sills.....	{ 2 pieces 4 × 4—10 ft.
	{ 2 “ 4 × 4—12 ft.
Plates.....	4 “ 2 × 4—12 ft.
Studding.....	{ 7 “ 2 × 4—12 ft.
	{ 3 “ 2 × 4—14 ft.
	{ 5 “ 2 × 4—16 ft.
Rafters.....	8 “ 2 × 4—12 ft.
Boards for sides and ends.....	250 sq. ft. novelty siding.
Roof.....	200 sq. ft. yellow pine.
50 ft. extra for dropping boards, etc.	
150 ft.....	1 × 3 in. white pine.
100 ft.....	1 × 2 in. white pine.

It is advisable to place 10 to 12 inches of cinders or crushed rock and 4 inches of concrete for floor. This insures good drainage and a dry floor.

A house the size convenient for the boys and girls poultry clubs has been designed by Prof. Graham. It is 8 feet wide

and 10 feet long and will accommodate 12 birds. The bill of lumber is as follows:

		(Labor not included.)			
Base.....	{	5 pieces	2 × 4—10 ft.	33	bd. ft.
		1 "	2 × 4—16 ft.	11	"
Studs.....		9 "	2 × 4—10 ft.	60	"
Rafters.....		5 "	2 × 4—12 ft.	40	"
Dropping boards					
(supports).....		2 "	2 × 3— 8 ft.	8	"
Roosts.....		2 "	2 × 3— 8 ft.	8	"
Plates.....		2 "	2 × 4—16 ft.	21	"
Opening.....		1 "	2 × 4—10 ft.	7	"
Total.....				188	"
Floor.....				100	" 2.80
Roof.....				120	" 3.36
Novelty siding.....				200	" 7.00
Dropping boards.....				25	" .70
Commercial roofing.....				1 roll	1.75
Cornice, frames, door.....				50 bd. ft.	2.10
Wire (1-inch mesh).....				15 sq. ft.	.22
Cloth.....				1½ yds.	.15
Hardware.....					1.00
					\$24.73

For illustration refer to Fig. 73.

The extension department of the Ohio State University has a novel idea, which is illustrated in Figs. 74, 75, 76, and 77. Many persons who desire to keep a few birds desire a small colony house, but neglect to build one on account of the lack of sufficient funds and the high cost of lumber. The house is made of two piano boxes, which at times may be secured very cheaply, and the first part of the construction is illustrated in Fig. 74. The boxes must be of the same size. The average piano box is 6 feet long, 5 feet high, and 32 inches wide at the bottom and 21 inches at the top. Make a foundation of 2 by 4 yellow pine scantling. Make the foundation level. Place the open boxes on the frame, with their open faces toward each other and 3 feet apart. Nail them securely to the frame.

Take two boards, 6 feet long and 12 inches wide, and saw as indicated by the dotted line in Fig. 77. Then nail the 6-

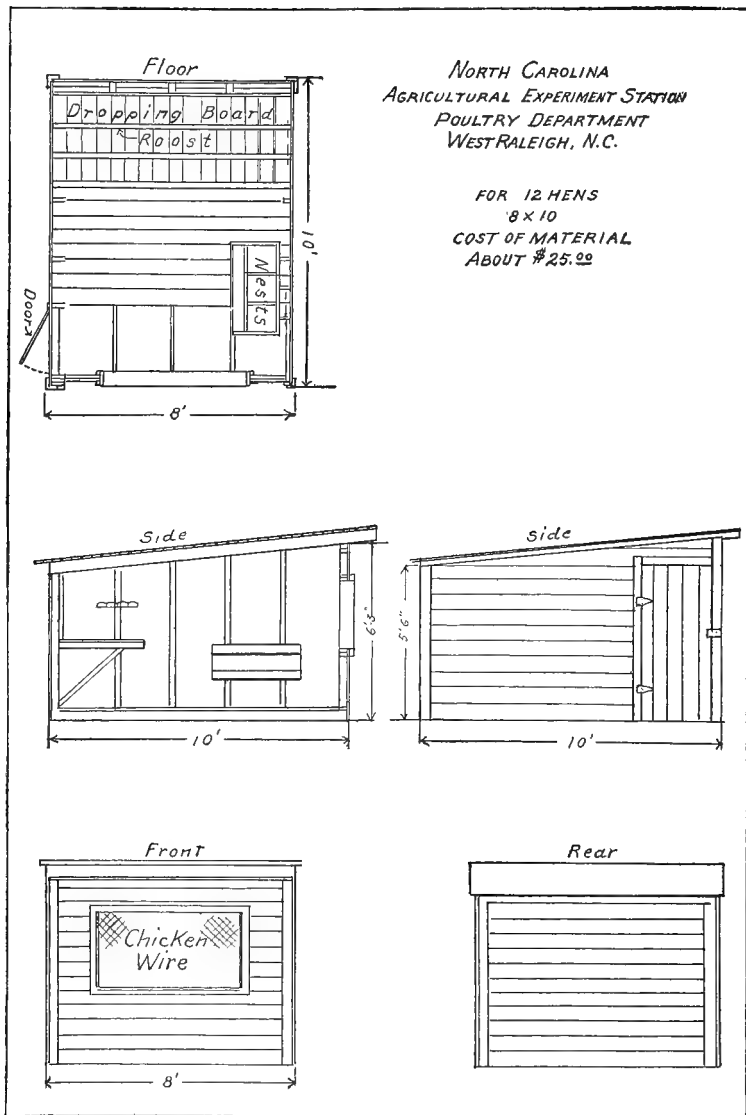

FIG. 73.—Photograph of a blue print from the North Carolina Exp. Station. This is a house suitable for the town lot or for the boys and girls poultry clubs.

foot boards to the inside of the ends of the boxes, securely fastening them together at the top and also forming the support for the roof of the house. Next remove the cleat *xx* from

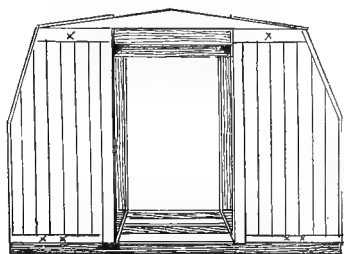

FIG. 74.

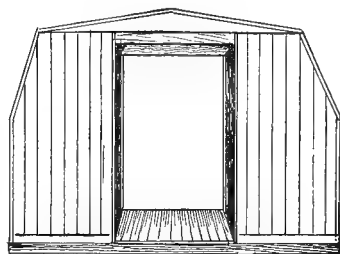

FIG. 75.

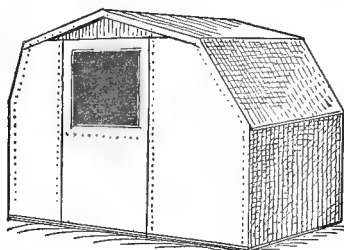

FIG. 76.

Figs. 74, 75, 76.—Three stages in the construction of a boy and girl's poultry house made from a piano box.

the top of the piano boxes, and nail the triangular pieces that were sawed from the 6-foot boards on the outside of those boards at the top so as to make smooth gable ends to the

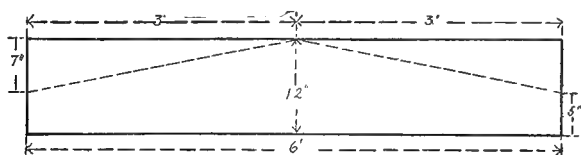

Fig. 77.—Diagram showing how to cut boards for the piano-box house. See description in body of text of how to construct the house.

house (Fig. 75). Finish the floor of the house with a part of one of the backs from the boxes. Then nail a 7-foot cleat on the inside of the rear of the house about 3 feet from the floor

and enclose the rear with a part of the other box back. If the backs from the boxes have been carefully handled, they together with the top of the boxes will complete the roof. Then the cleats marked *xx* should be removed, and the outside of the house presents flat surfaces to receive the roofing paper with which it is to be covered.

LIST OF MATERIALS FOR THE PIANO-BOX HOUSE

2 piano boxes.....	\$3.00
2 rolls 1-ply roofing paper.....	3.50
1 piece 2 × 4 × 8 ft. yp. }	.62
1 piece 2 × 4 × 12 ft. yp. }	
1 piece 2 × 12 × 16 ft. yp. }	
1 piece 2 × 12 × 12 inch No. I. Y. P. brace.....	.32
1 piece 1 × 12 × 8 ft. yp. }	.52
2 pieces 1 × 4 × 12 ft. yp. }	
2 pounds 7-penny nails.....	.06
1 pound 8-penny wire nails.....	.04
1 pound 16-penny wire nails.....	.05
1 pair strap hinges.....	.10
1 piece poultry netting 2 × 2 × 6 ft.....	.10
	\$8.31

The door is 3 feet wide and 5 feet 1 inch high, and is constructed with an open top so as to admit fresh air and sunlight. The frame of the door is made of 4-inch strips. The lower half is filled with 1-inch boards and the upper is covered with 1-inch poultry netting. The door is made to swing outward on a pair of 5-inch strap hinges. An opening, 8 inches wide and 10 inches high, is cut in the rear next to the floor through which the hens enter and leave. The roofing paper should first be placed on the front and rear and tacked temporarily. The paper on the sides should extend up one side over the roof, and down the opposite side and overlap the top and sides of the front and rear about $2\frac{1}{2}$ inches, making the house perfectly tight.

A cheap and durable roofing may be made as follows: Secure a sheet of brown paper, tar it on both sides, then tar the top of the roof, lay the paper on, and drive a few nails through; repeat this till several layers of tar and paper have been applied. Such a roof will last for years.

This is an excellent house for the boys and girls poultry clubs.

New Jersey Experiment Station in summarizing their experiments in housing fowls conclude that a large amount of glass in a poultry house is undesirable, that the shed roof furnishes ideal conditions at a minimum cost, and that the twenty-

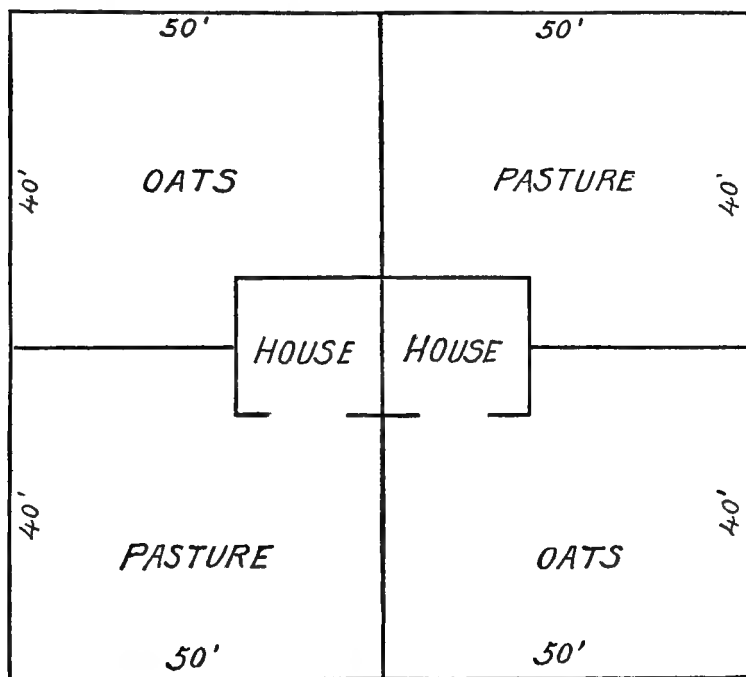

FIG. 78.—A diagram of a double unit system house, with two yards to each house. As indicated one pen is sown in oats, which aids in rendering the ground free from contamination, while the other yard is used for pasture. The oats should be pastured when it is from 2 to 4 inches high.

foot house is more efficient for medium to large flocks than the smaller houses because it can be constructed more economically. The birds are farther from the openings and hence better protected.

In yarding fowls it is estimated that to maintain a perma-

ment sod there should be 150 square feet to each bird. It is difficult to maintain a permanent sod near the house. Where the double yardage system is used, that is, where the birds are allowed to run a while in one yard and green feed raised



*As baby chicks
take care of by the hen in the
combination sitting & brooding coop*



*As baby chicks
retire to brooding*



*As pullets on range
a good range fence*



*As layers
one unit house for 500 layers*

FIG. 79.—Showing housing methods in the three stages of poultry work.

for them in the second yard, 75 square feet per bird will be sufficient. As soon as the green feed, as oats or rye, in the yard being cultivated is 4 or 5 inches high it is pastured by turning the birds into this lot and seeding down the first lot.

THE CONSTRUCTION OF THE UNIT SYSTEM HOUSE

Like in the construction of all poultry houses, the unit system house should be so constructed that there will be a uniformity of temperature, general good health of the flock conducive to good egg production, economy of construction, and a saving in the work of care of the flocks that are to be kept in it.

Poultry houses should always be provided with plenty of head room, so that the poultryman can work in the building without inconvenience. In the unit system house the front should be 10 feet and the rear 7 feet high. The deeper and wider the house, the higher the roof should be made to be in proper proportion. On the other hand, a colony house 8 by 10 feet could have a rear wall only 4 feet high and the front 6 feet and be in good proportion, while a building 14 feet square could have a rear wall 6 feet and a front wall 8 feet high and that be in good proportion.

The floor material may be of boards, dirt, gravel, or cinders and concrete.

Board floors should have a coat or two of asphalt, which should be applied hot. The fall of the year is a good time to give the buildings a new coat of paint as this preserves the wood and gives visitors a good impression.

The board floors are used to a considerable extent in the warmer parts of the country where there are no cold winters. The floor is located 2 feet above the ground. This allows of a free circulation of air and does not furnish a favorable place for rats and other nocturnal vermin of that character. This type is not so satisfactory for colder countries. Dirt is used to a great extent. The top of the floor should be at least 1 foot above the surrounding ground, so as to ensure it remaining dry in wet and rainy times. The dirt floors are more or less harbors for rats, who find hiding-places under the sills, and any other material of that nature that may be upon the floor. It furnishes a temptation not to be resisted by the hens in taking dust-baths, and the floor is not easily kept level. Gravel can be hauled from most creeks or rivers, and 12 inches on the floor of the house makes good drainage and ensures a dry floor. The same may be said of cinders, which may be secured in many localities for the hauling. The best

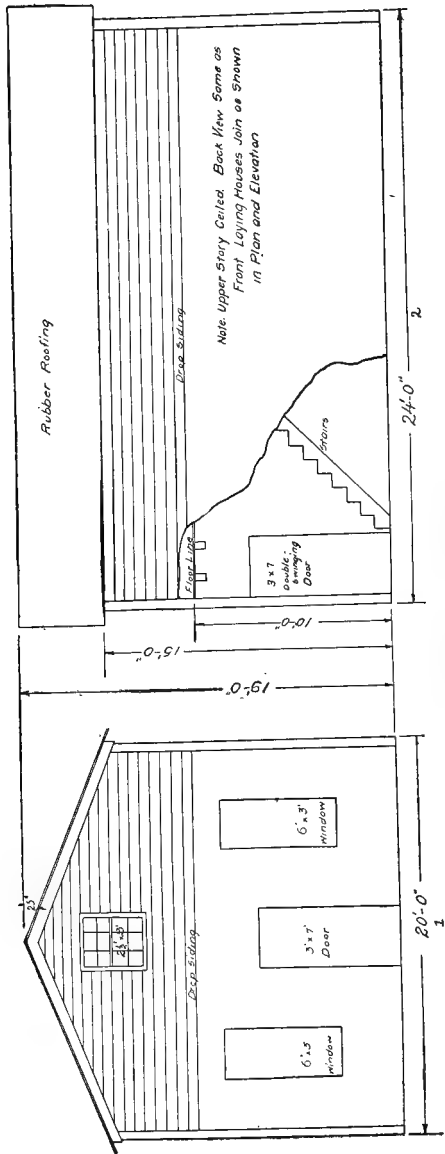

1 1/2 STORY MIXING HOUSE

Fig. 80.—1, End elevation of main building, showing the two full windows, door, and half window in the attic. 2, Side elevation, showing location of stairs. The door is the entrance into one wing.

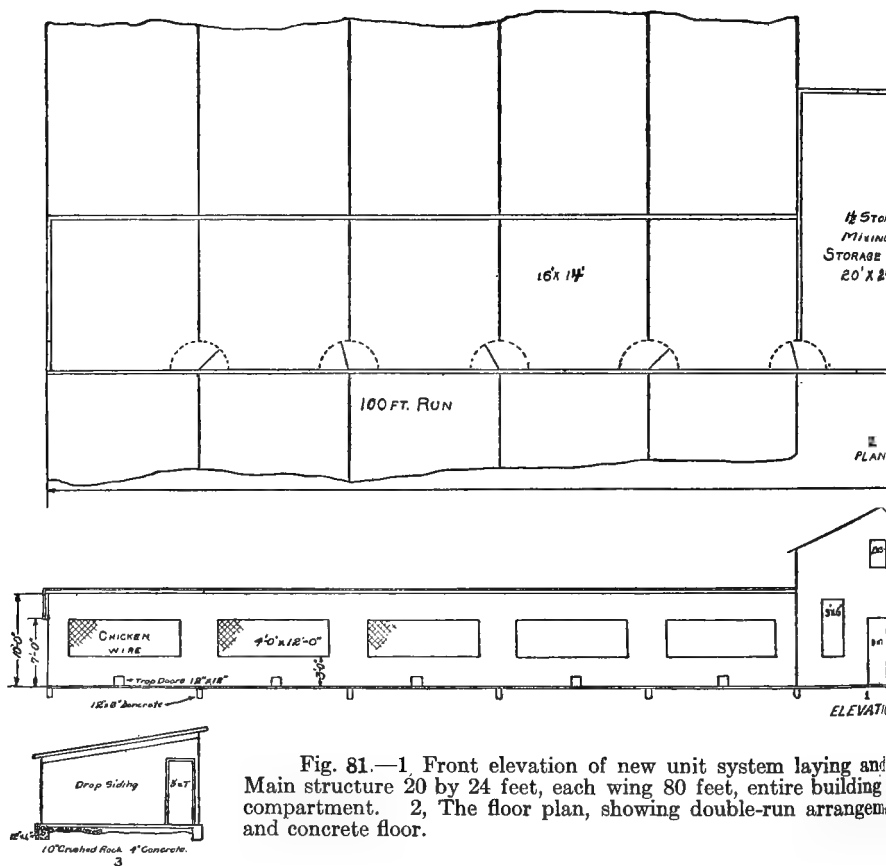
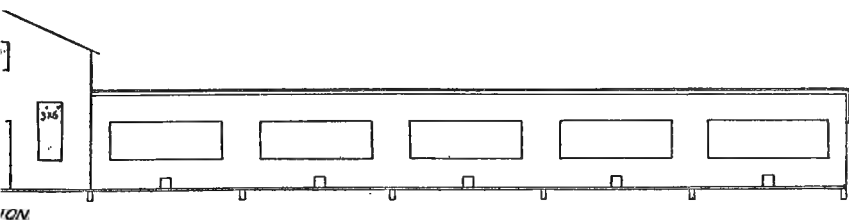
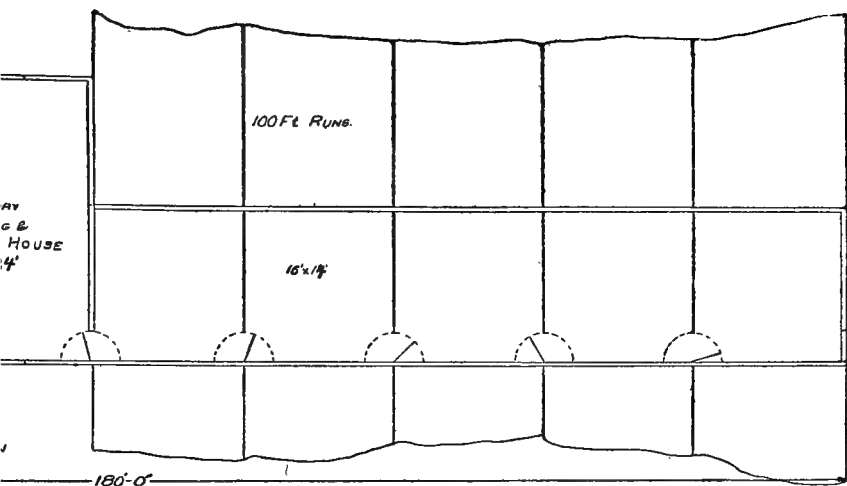
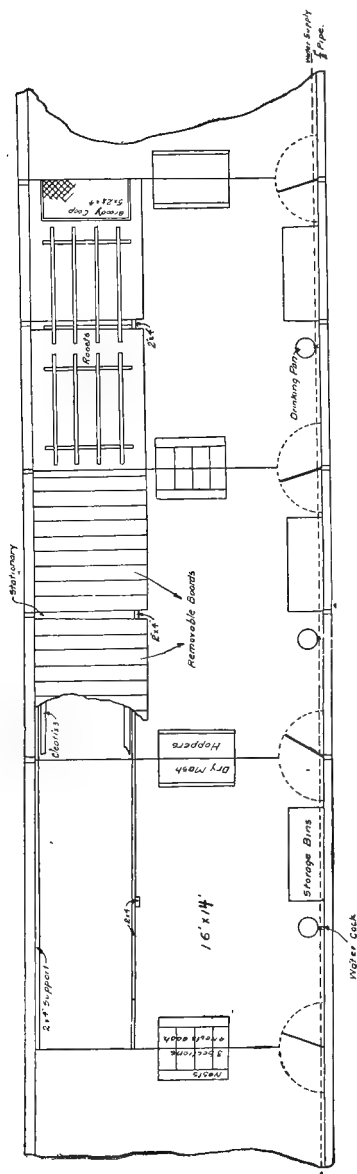

Fig. 81.—1, Front elevation of new unit system laying and Main structure 20 by 24 feet, each wing 80 feet, entire building compartment. 2, The floor plan, showing double-run arrangement and concrete floor.



1 breeding house of the North Carolina Experiment Station and A. and M. College. 180 feet. It accommodates ten flocks of 50 birds each. Note the open front to each section. 3, End elevation, showing section of concrete foundation, drainage, cinders,



LAYING HOUSE

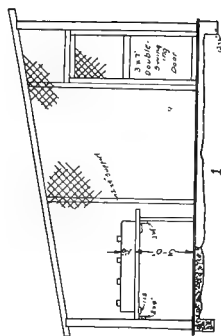

FIG. 82.—1, End elevation, showing swinging door in partition between two compartments, wire netting of partition, end view of dropping boards with their supports, on which are located the roosts, four in number. The dropping boards are 3 feet off the floor and the roosts are 1 foot off the dropping boards. 2, Three compartments with the dropping boards, roosts, and broody coop. Also location of storage-bins, swinging doors, mash hoppers, nests, and waterstands.

and most substantial foundation and floor is made of concrete. Figures 81 to 82 show views of the construction of the main part and one wing of the new 180 feet unit system breeding-house at the North Carolina Experiment Station. Figure 83, 4 shows the survey outfit and a means of finding the level. When this is not available a line can be stretched and, by aid of the level and straight edge, the level line can be obtained. Figure 83, 7 shows the forms in which the concrete foundation is made. This foundation is 4 inches wide and 1 foot above the ground at the highest point. It extends into the ground 1



FIG. 83.—Construction of the foundation and floor. 1, The cinders, which are being leveled and tamped (2) after being wet down (3); 4 is the survey outfit to find the level; 5, mixing the concrete; 7, the forms which extend 1 foot into the ground and in which the 4-inch concrete wall is made; 8, the 3-inch coat of coarse concrete; 9, the bolts set into the concrete to which the 4 by 4 inch sills are to be bolted.

foot. The floor space inside the frames is filled in with cinders of a good grade to within 4 inches of the top of the foundation frames. These cinders are wet down and tamped (Fig. 83, 2, 3). Figure 83, 8 shows 3 inches of crushed rock and sand and cement. The crushed rock and sand should constitute 7 parts and Portland cement 1 part. The gravel, sand, and cement are mixed dry, then wet down and mixed again to the proper consistency, loaded into wheelbarrows, wheeled to the proper places, and tamped down. On top of this is placed

1 inch of cement, made by mixing 1 part cement to 2 parts sand. In this construction the cinders were from 12 inches deep in the highest place to 18 inches deep in the lowest place. This, together with the deep foundation, makes the best kind of drainage and ensures a dry floor under any climatic conditions. Figure 84 shows the foundation finished, ready for the superstructure. Here will be noted the smooth floor and the bolts, which have been set into the cement and to which the sills are to be bolted.

In warm climates it is not necessary to provide the house with drop curtains, so that windows are not necessary. In



FIG. 84.—Floor: 1, The finished concrete floor ready for the superstructure; 2, the exposed wall 1 foot above the ground at the highest place and 1 foot into the ground. This has had a finish coat of cement; 3, the bolts set into the concrete to which the 4 by 4 inch sills are to be fastened. This floor varies from 1 foot to 1½ feet thick—4 inches concrete, the balance tamped cinders for underdrainage. This ensures a perfectly dry floor.

colder countries it is necessary to provide windows and drop curtains, as indicated in the plans for the smaller houses. In this type of house ventilation is by the process of diffusion.

The walls for the ten compartments for the accommodation of the birds are 10 feet high in front and 7 feet behind. Each compartment is 14 feet deep and 16 feet long. The outside walls are constructed of shiplap siding of good grade and clear of knotholes.

It will be noted that the roof is of single span or shed type. The roof extends 12 inches beyond the front and back walls.

The rafters are 2 by 4 inches and covered with sheathing or boxing boards, and are provided with a 4-inch facing. The roof is covered with a good grade of two-ply rubberoid.

Each compartment in front is provided with an opening 12 feet long and 3 feet high, and covered with $1\frac{1}{4}$ inch mesh chicken netting. The lower edge of this space is 30 inches from the floor. A hole 12 inches square with trap-door is provided in the rear of each compartment through which the chickens may pass. The lower edge of this opening is level with the sill.

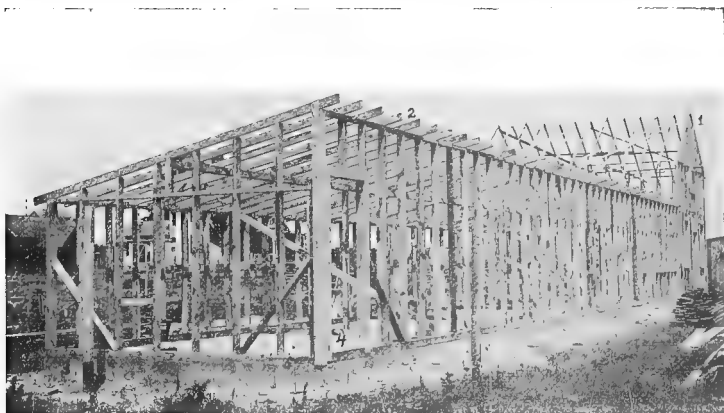

FIG. 85.—The frame work of the superstructure, showing the main building and one wing: 1, The main building; 2, the wing; 3, the foundation; 4, the cement floor seen through the end door of first compartment; 5, one of the 4 by 4 inch sills fastened by a bolt embedded in the concrete.

The doors are 3 by 7 feet with proper door jams and sills. The main part of the building is provided with one in the front and one in the rear, and each wing is provided with one at either end. A partition is constructed between each of the five compartments for the birds. These partitions are constructed of boxing boards to a height of 3 feet, with 2 inch chicken netting over the balance fastened securely to 2 by 4 inch studding placed 2 feet apart. Each partition is provided with a swinging door, made to swing out and in, and is 3 by

7 feet. Fasteners are provided so the doors can be fastened and opened from either side. (See Fig. 87, 2.)

Each of the five compartments are provided with four roost poles, each extending the entire length of the compartment, and are located in the rear. These roost poles are made of 2 by 4 inch lumber, with top edges rounded a trifle and the entire pole planed. These are nailed to 2 by 4 inch lumber,



FIG. 86.—Equipment each compartment is furnished. 1 is the storage box for morning and evening scratch feeds. 2 are the trap-nests. 3 shows the dropping boards which are removable. 4 illustrates how the roosts are arranged so they can be suspended from the ceiling during cleaning of dropping boards. The roosts are hinged to the studding. 5 is the broody coop.

which is blocked 8 inches high off the dropping board or platform. The rear roost pole is 10 inches from the wall and the poles are 14 inches apart. They are built on the level. The 2 by 4 inch lumber is bolted at the rear, so the roosts can be raised and fastened to the roof during cleaning of the dropping board.

A solid platform is constructed under the roosts. These

boards are laid crosswise and constructed in sections, so that they are easily removed. The material used is No. 2 pine flooring. The platform is 39 inches off the floor. The platform extends 15 inches in front of the front roost.

Each of the ten compartments are provided with twelve trap-nests, made in two sections. A mash hopper provided with compartments for dry mash, charcoal, grit, and shell; and a



FIG. 87.—Equipment each compartment is furnished. 1 is the water faucet. 2, the partition door made to swing out or in. 3, a slide bolt made of wood that is not affected by wet or dry weather and can be manipulated from either side. 4, the mash hopper. 5, the partition boarded 3 feet high, and 6, 2-inch mesh wire netting over the balance.

storage-box provided with a compartment for morning scratch feed and one for evening scratch feed; a water faucet to furnish water and a broody coop. The broody coop is made 2 feet wide with slatted bottom. These slats are 2 inches wide and laid 2 inches apart. The front is provided with a door which is hinged, so that it swings out, and is fastened with a button (Figs. 86, 87).

The main part of the building is 20 by 24 feet, and provided with a comb roof. The roof is of the same material as the ten compartments for birds.

The roof may be covered with shingles, tar paper, rubberoid, asbestos roofing, tar and gravel, or metal.

Each end is provided with two full windows on the first floor and a half window on the second floor.

This building is one and one-half stories high. It is 14 feet to the square or eves. The roof is one-third pitch. The floor of the second story is constructed of tongued and grooved flooring, with 2 by 6 inch girders with two pillar supports. These pillar supports are 6 inches by 6 feet. A stairway 30 inches wide is provided to go from the first to the second story. The floor of the first story is of concrete, the same as the two wings. The interior is provided with storage-bins, grinding and mixing machinery.

The studding in all the construction are not more than 2 feet apart. The outside is constructed of drop siding, in conformity to the balance of the building.

Buildings should be painted with a good white lead paint and linseed oil. This should be repeated once every three years. Brown of England recommends gas tar mixed with paraffin oil or creosote. These not only protect the wood but keep down parasite life.

LIST OF MATERIALS

Cinders.....	80 yards
Sand.....	14 "
Gravel.....	41 "
Cement.....	65 barrels

FRAMING:

- 16 pieces 4" × 4" 16' long for base and corner studding.
- 24 pieces 4" × 4" 14' end sills front base.
- 2 pieces 4" × 4" 12' sides of 1½ story.
- 1 piece 4" × 6" 16' long cross-beams for 1½ story.
- 1 piece 4" × 6" 8' long cross-beams for 1½ story.
- 2 pieces 4" × 6" 8' long for column.
- 30 pieces 2" × 6" joists.
- 52 pieces 2" × 4" 16' long studding and rafters for 1½ story.
- 24 pieces 2" × 4" 12' long for rafters.
- 10 pieces 2" × 4" 10' long.
- 38 squares rubberoid roofing.

- 60 machine bolts $\frac{5}{8}$ " \times 8" for sill anchors.
- 4 pieces 2" \times 4" 12' long for end plates.
- 350 pieces 2" \times 4" 10' long for studding, braces, and perch poles.
- 140 pieces 2" \times 4" 16' long for rafters, beams, top plates.
- 60 pieces 2" \times 4" 12' long for perches, trap-nest supports.
- 500' strips $2\frac{1}{2}$ " \times $\frac{3}{4}$ " for broody coops.
- 4500' sheeting.
- 4600' drop siding.
- 1800' flooring for floor of second story of main structure and dropping boards.
- 150 stakes 2" \times 3" \times 4.5'.
- 150 braces 1" \times 3" \times 4'.
- 150' 1" quarter round.
- 175 1" \times $3\frac{1}{2}$ " corner boards.
- 250' $\frac{1}{2}$ " \times $1\frac{1}{2}$ " door and window strips.
- 40' $1\frac{1}{4}$ " \times $9\frac{1}{2}$ " for stair treads.
- 500' $1\frac{1}{16}$ " \times 6" lineal feet.
- 2 pieces 2" \times 12" for stair stringers.

HARDWARE:

- 450 pounds wire nails (No. 8).
- 8 pair double swinging hinges.
- 6 pair $3\frac{1}{2}$ " door hinges.
- 6 door locks.
- 40 $\frac{1}{2}$ " \times $4\frac{1}{2}$ " bolts for perch hinges.
- 40' well chain for hanging perches.
- 200' 3.4" galvanized pipe for water-supply.
- 1 stop and waste cut off.
- 10 $\frac{3}{4}$ " hose bibs.
- 11 $\frac{3}{4}$ " galvanized T's.
- 5 $\frac{3}{4}$ " galvanized L's.
- 1 $\frac{3}{4}$ " galvanized unions.
- 10 pair $1\frac{1}{2}$ " hinges for broody coops.
- 130 buttons for trap-nests and broody coops.
- 120 trap-nests—600' pine lumber.
- 10 storage-bins—500' pine lumber.
- 10 mash hoppers—400' pine lumber.
- 8 doors between compartments.
- 8 door latches.
- 4 door frames 3' \times 7'
- 4 doors 3' \times 7'
- 2 half windows with frames.
- 4 windows 3' \times $5\frac{1}{2}$ ' (lights complete).
- 4 window frames.
- 6 paneled doors.

WIRE NETTING:

- 40 yards wire netting 48" wide $1\frac{1}{4}$ " mesh for open fronts.
- 165 yards wire netting 24" wide 2" mesh—for partitions.

- 10 yards wire netting 36" wide 2" mesh.
 54 yards wire netting 18" wide 1" mesh.
 5 pounds staples for fastening wire.
 10 trap-doors in rear of compartments—150'.
 10 door slides $2\frac{1}{2}$ " \times $\frac{3}{4}$ "—60 lineal feet.

THE CONSTRUCTION OF THE NORTH CAROLINA PORTABLE POULTRY HOUSE

List of Materials

Use	Size, in.	Length in feet	No. pieces	Board measure
Sills (runners).....	4 \times 8	16	2	86
Sleepers.....	2 \times 4	10	6	39
Studding.....	2 \times 4	10	5	32
Plates.....	2 \times 4	14	2	18
Rafters.....	2 \times 4	12	6	48
Supports for dropping boards.....	2 \times 4	14	2	18
Roosts or perches (dressed on all sides)..	2 \times 4	12	3	24
Perch supports.....	2 \times 4	16	1	11
Nest supports and braces for drinking platform.....	2 \times 4	12	2	16
Broody coop, studding and sills.....	2 \times 4	14	2	18
Lattice for broody coop and bottom of drinking platform.....	1 \times 2	4	24	16
Material for nests:				
Door.....	1 \times 8	14	1	10
Strip at bottom of door.....	1 \times 4	14	2	9
Strip at top in back and front to hold wire netting.....	1 \times 2	14	2	5
Board at bottom in back of building.	1 \times 6	14	1	7
Partition between nests.....	1 \times 14	14	1	16
Runboard in front of nests.....	1 \times 4	14	1	5
Battens for door and dropping boards.....	1 \times 4	32 lineal feet		11
Sheathing.....				180
Total.....				569
Flooring.....				500
Siding				} made from above flooring.
Dropping boards				
Hardware:				
Hinges for door, nests fronts and roosts.....				5 pairs
Chain to raise roost poles.....				2 ft.
Rubberoid or other equally good roofing.....				180 sq. ft.
Wire netting:				
For front, back and sides of broody coop $\frac{3}{4}$ -in. mesh, 36 in. wide.....				6 yds.
For top and bottom of nests, $\frac{1}{4}$ -in. mesh 30 in. wide...				5 yds.

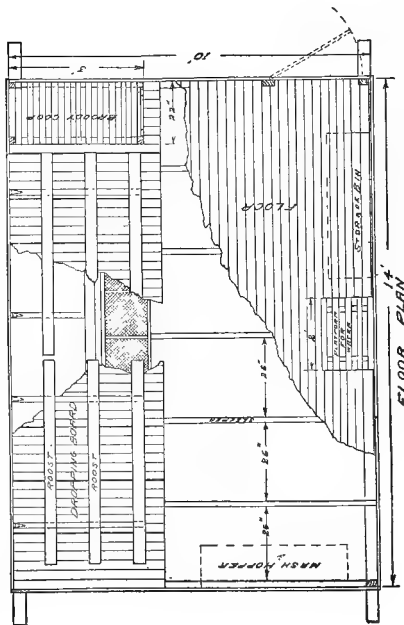
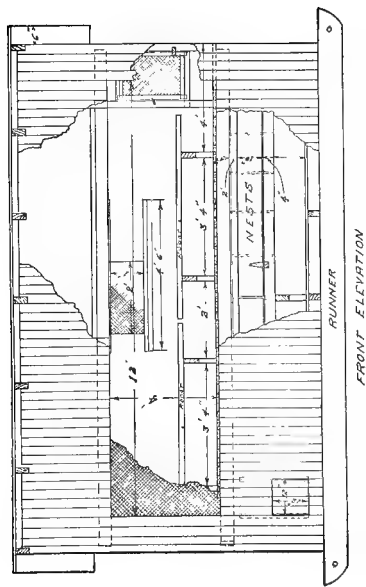
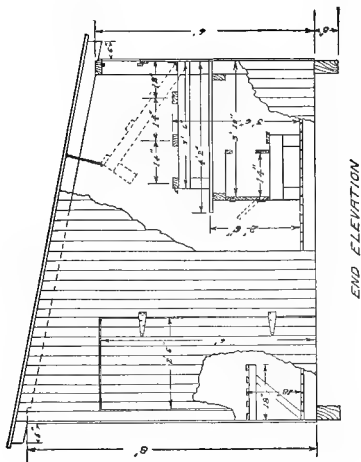

THE NORTH CAROLINA FARMERS

PORTABLE POULTRY HOUSE
 PLANNED AND APPROVED BY B. F. HARUP
 N. C. EXPERIMENT STATION ¹⁹¹⁰ R.-M. COLLEGE
 WEST RALEIGH, N. C.

SIZE 10 X 14, CAPACITY 50 HENS, 4 COCKS
 ESTIMATED COST OF MATERIAL \$20.50
 DRAWN BY E. B. NICHOLS
 SCALE 3/4" = 1 FOOT

Fig. 88.—Plan for the construction of the farmer's portable poultry house.

The sills or runners should be cut as sled runners as shown in Fig. 88 and a hole made near the end so that a team can be hitched to the house when it is to be moved. The runners are placed 10 feet apart and upon these the sleepers are placed. The two outside sleepers are 14 feet from outside to outside. The other sleepers are placed 26 inches apart and nailed. Next the studding is cut and placed, plates laid, and the rafters put in position. These are to be 26 inches apart. Next the sheathing is placed and the roofing put on after which the siding is put on. This is done for protection in case of rain during the building processes. The siding consists of tongued and grooved flooring and is placed as illustrated in Fig. 88. The front of the building is left open until the floor has been laid and the dropping boards and roost poles constructed. The supports for the dropping boards are put in place, the back one is nailed on the front of the corner studding so as to allow one opening between the support and wall to prevent the holding of droppings. The front support is held at each end with a 2-inch by 4-inch timber placed at each end, perpendicular to the floor and nailed to the wall. Next the dropping boards are constructed in sections so they may be taken out of the building, disinfected, and sunned. These sections are 18 inches wide with two cleats 1 inch by 4 inches and 16 inches long, nailed 10 inches from either end of the boards. These boards extend across the back side of the house, but those under the broody coop may be nailed to the board supports. The roost poles are made of 2-inch by 4-inch timbers, as shown in Fig. 88. These roost poles are to be dressed on all four sides and are laid down flatwise so as to make a flat surface for the birds to perch upon, which prevents injury to the breast bone in case young chickens are placed in the house. The top corners of the poles are rounded, just a little, only enough to take off the sharp corner. The roost poles are made in sections and supported in the middle part with a short piece of 2-inch by 4-inch timber, which is nailed to the cross support of the roosts. The cross supports are hinged to the wall at the back so the front can be raised. A chain 12 inches long is provided for each section and is fastened to the rafters, and the links

can be hooked over a nail driven in the middle of the front pole, so as to keep it in position when raised.

The nests are built in two sections, six nests in each section. An 8-inch board is hinged on the front of each section so that the nests may be reached easily. There is a narrow board at the bottom, both back and front of the nests. The top and bottom of the nests are covered with $\frac{1}{4}$ -inch mesh screen wire so as to allow a current of air through them. This gives the ample ventilation which must be provided for the nest in hot weather. A 4-inch board is arranged in front which serves as a step for the hens. The nests are made removable and located just under the front portion of the dropping boards, and are supported at either end and in the middle by 2-inch by 4-inch timbers.

The broody coop which is shown in the front view and floor plan is to be constructed with 2-inch by 4-inch timbers used as studding and rails to hold the bottom. The coop is then slatted up with 1-inch by 2-inch boards placed 2 inches apart. The studding runs from the dropping boards to the sheathing. The coop is to have a door 2 feet by $1\frac{1}{2}$ feet, and it should be covered with $\frac{3}{4}$ -inch mesh wire netting and hinged on the side next to the wall.

In the middle on the front side there is a platform upon which is set the vessel containing the drinking water. The floor being covered with straw or leaves used as scratch material, it is necessary to have the pan of water or milk off the floor. This platform is 18 inches high, 18 inches by 2 feet, made of 1-inch by 2-inch slats. The spaces between the slats is to be 1 inch. The platform is supported by 2-inch by 4-inch timbers.

An opening 3 feet by 12 feet is left in the front of the building for light and ventilation. There is also an opening 1 foot by 2 feet in the center and top of the back side of the building for ventilation in the summer time. This latter opening is closed in the winter time. Both the back and front ventilation openings are covered with chicken netting.

If it is desired to use a drop curtain, a window is placed in one side of the front opening. This window furnishes light while the curtain is down. By putting in the window the

opening is cut about 3 feet shorter. Ducking is used as a drop curtain. This cloth is tacked to a frame just the size of the open front. This cloth, being porous, allows plenty of ventilation and at the same time keeps out the winter wind, snow, and rain. The window supplies the light during this time.

It is the intent to keep in the building the scratch feed used in the morning and evening. This feed is kept in the double compartment storage bin. The dry mash and shell is kept in the mash hopper. The water in a receptacle on the platform made for that purpose. The nests and the broody coop are also located inside. The floor is provided with a layer of leaves or straw about 1 foot deep in which is thrown the grain morning and evening so that the birds scratch for it and get their necessary exercise. Thus in rainy weather the birds do not find it necessary to get out into the rain unless they choose. On snowy and stormy days they are likewise protected.

Commercial egg farms usually house 500 hens in each unit. The house most in use is the shed type, open front. The building may be 14 to 16 feet wide and 80 to 100 feet long, and in warmer parts of the country 2 feet off the ground. A cheaply constructed building may be made of boxing boards, the roof covered with rubberoid and the sides and ends with tar paper. The boards are usually placed perpendicular on the sides and ends and the tar paper crosswise nailed using strips of tin.

Many commercial men keep their birds the year round in the house. This is the intensive method. Others have small runs, this being the semi-intensive method. When the fowls run at large on the farm they are under range conditions.

Fencing Materials.—Various kinds of woods are used for posts. The woods that are most durable are white oak, cedar, and hedge. Woods less durable are catalpa, hickory, black oak, and pine. Posts may be round, split, or sawed. Round posts should be at least 6 inches in diameter at the base and peeled. Sawed posts are usually 5 inches square and are of heart wood. Wood posts are made more durable by treating the base with creosote. Experiments conducted

with black gum, sweet gum, tupelo, short leaf, and loblolly field pine showed that creosote preserved perfectly these woods up to nine years, the end of the experiment.

Cement and steel posts are most desirable on account of their lasting qualities. The end and corner steel posts are set in cement, the line posts are driven.

The wire fencing may be of six-sided meshed chicken netting, or of three-sided mesh netting as shown in Figs. 69 and 70. This wire does not hold its shape well and is best used with a frame made of 1-inch by 4-inch pine lumber. A barbed wire may be stretched at the lower border next to the ground and one at the top and the netting lashed to it either by hog rings or by pieces of wire. Poultry fencing wire as shown in Fig. 71 is the best. It is more durable on account of being made of heavier wire. It holds its shape.

Fences for young ducks should be 2 feet high, for old ducks 4 feet; for fowls of the American and English breeds 5 to 6 feet high, and for Leghorns and Campines 8 feet high. Three or four strands of barbed wire may be stretched on the top. These wires are placed about 4 inches apart.

Fence posts may be of concrete, steel, round oak, or split or sawed posts. Cedar and white oak are most durable. Hedge posts are very durable. As a rule woods that grow quickly, as hickory, do not last so long. Heart wood lasts longer than round posts made from the tops of the trees.

Posts should be set at least 30 inches in the ground. The bottom of the post should have the ground thoroughly tamped around it. The ground throughout the entire length of the post should be thoroughly tamped.

AN UP-TO-DATE POULTRY AND FRUIT FARM

In buying a farm there are many factors that should be carefully considered, such as location, market conditions (both for buying and selling), climate, good roads, good neighbors, schools, churches, soil, water-supply, healthfulness, size, and shape of the farm.

Locate in a good community, where there are good schools and churches, which means that you will have good neighbors.

Study the market conditions carefully by getting book accounts and reports from the experiment stations for your particular locality. Wherever there is a restricted production on account of large cities, and you can locate within a reasonable distance, you will find good market conditions. The parcel post is making it possible for one to locate farther away from the consumer, as it has a tendency to eliminate apparent distance.

Locate where the climate is healthful for your family as well as your poultry. Good roads are a big advantage, as they are time-savers by facilitating travel.

The farm itself should be located so as to avoid a northern slope. With a southern and eastern exposure you will get the early spring warmth and be protected from the prevailing cold winds. Some shelter that will protect your building from the prevailing cold winds means several degrees in temperature in your houses. This shelter can be orchards, woods, or hills.

Air drainage is an important factor, and your farm should be so located that when the cold air settles it will settle or drain away from your farm buildings and orchard. It is always colder in the valley than on the top of the hill when protected. Locate your buildings above the lowest part of the farm, thereby avoiding the settling or draining of the cold air into your buildings.

Natural grass meadow land is a great deal more profitable than a dry gravelly soil, where it is almost impossible to raise anything. Have your buildings high and well drained, but do not forget or neglect to have good grass land for a pasturage for your poultry. Choose a good soil (get a soil map from your experiment station). If you are fortunate enough to have a good spring on a hillside of the farm or running water you will find it a great asset.

The size of the farm depends, of course, upon the extent of your future plans. A 10-acre farm will take care of a thousand fowls and allow of your staying in the business indefinitely. With large fields, square in shape, you will find that they are accessible and easily ploughed and tilled.

The accompanying plan (Fig. 89), designed by Mr. Thayer,

AN UP-TO-DATE POULTRY AND FRUIT FARM

AS SUGGESTED BY FREDERICK H. THAYER,
OF BALTIMORE.

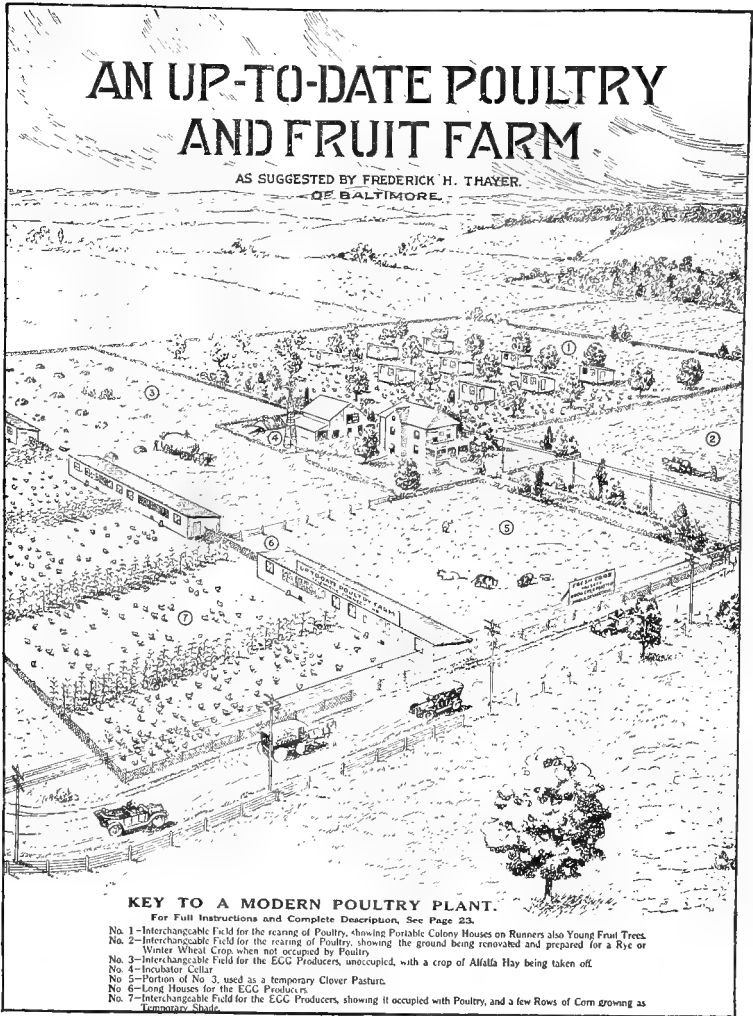

KEY TO A MODERN POULTRY PLANT.

For Full Instructions and Complete Description, See Page 23.

- No. 1—Interchangeable Field for the rearing of Poultry, showing Portable Colony Houses on Runners also Young Fruit Trees.
- No. 2—Interchangeable Field for the rearing of Poultry, showing the ground being renovated and prepared for a Rye or Winter Wheat Crop when not occupied by Poultry.
- No. 3—Interchangeable Field for the EGG Producers, unoccupied, with a crop of Alfalfa Hay being taken off.
- No. 4—Incubator Cellar.
- No. 5—Portion of No. 3, used as a temporary Clover Pasture.
- No. 6—Long Houses for the EGG Producers.
- No. 7—Interchangeable Field for the EGG Producers, showing it occupied with Poultry, and a few Rows of Corn growing as Temporary Shade.

FIG. 89.—A model of an up-to-date poultry plant.

is square in shape, with the home buildings in the center, where you will have a full view of your poultry and buildings at all times.

It will be noted that in field No. 1 there are colony houses and fruit trees. This field is used for the growing of young stock. The houses are made portable, that is, placed on runners, so that they can be moved readily from field to field. Hovers of some description, either coal or oil heated, can be placed in them and kept there till the youngsters no longer require heat. These hovers when not needed can be removed, and the growing stock allowed to remain in the same colony house undisturbed.

While field No. 1 is being used for the growing stock, field No. 2 can be plowed and some useful crop grown. By alternating these fields from year to year we prevent the soil from becoming contaminated with disease.

Fields 3, 5, and 7 are alternated the same way. While one is occupied with poultry the other is growing some valuable crop. All of the fields may be set out in young fruit trees, and in a few years the ground will be yielding two crops, one of poultry, one of fruit.

Corn is sown in field No. 7 and grown as a temporary shade. No. 6 represents a long laying house, which we recommend for commercial egg production. These houses can be built any length. A house 100 feet long and 20 feet wide will accommodate 500 layers and provide plenty of room for exercise during the long winter months when the birds are confined.

The fruit trees keep the poultry cool in the summer time, which is essential, as excessive warmth causes the birds to suffer severely. It impairs their growth, health, and egg production.

Apples are the best all-round fruit for the poultryman, although in some localities nuts, as English walnuts and pecans, are successfully grown. The trees should be planted 45 feet apart, and on a plot of ground square in shape and containing 10 acres there can be 196 trees planted.

Apples are not so perishable as some other fruits, as they can be hurriedly picked and packed and shipped in spare times or

when market demands are best. The picking comes at a time when you are not so busy with your poultry.

In the rotation of crops those grains most needed to feed the birds can be used, such as corn, wheat, and oats. Each field being cultivated every other year gives the trees sufficient cultivation. Sheaf wheat and oats can, to a certain extent, be fed, as there is needed in the houses scratch material in which to throw the grain ration.

THE FARM FLOCK

The most successful and profitable way to handle the farm flock is to have the poultry house portable. (See Fig. 88.) The timbers supporting the building should be about 4 inches thick and 6 or 8 inches broad and dressed like a sled runner so that horses can be hitched to it and move it from place to place.

Corn fields, cotton fields, beet fields, cane fields, and orchards make excellent locations for the poultry. They also do well in fields of rape, vetch, cowpeas, and soy beans.

The breeding stock may be allowed to run in a field in one part of the farm and the youngsters in another field. The sitting and brooding coops or the movable colony brooder houses may be located in the cornfield or orchard and the chickens allowed the run of the clean grass, orchard run or ploughed field from the time they are baby chicks.

By this method a greater percentage will be raised. Two crops will be yielded by the same ground, that is, a crop of chickens and a crop of corn or fruit. The orchard furnishes the needed shade and the same may be said of the corn.

It has been found that hens running in cultivated fields do not interfere with certain crops as corn or cotton, and that one hundred hens through the day will in the course of a year void approximately three-fourths to one ton of valuable fertilizer. The bugs, insects, and worms they consume furnish them animal food, the crop is protected.

The New York Experiment Station estimates that each one hundred hens will directly benefit the ground on which they run at least \$15.00 a year.

The straw and litter used in the houses for scratch material, after it becomes of no further use for scratch material, is valuable as a fertilizer on the field and helps to make humus needed in the soil for the best crop production.

One hundred hens will consume from 300 to 500 pounds of oyster shell a year, some of which goes back to the land.

Hens act as scavengers, not only consuming hundreds of pounds of insects in the course of the year, thus protecting the crops from pests, but act as scavengers by picking up waste grain and other food material.

The cost of raising hens on such free range conditions is only about one-half as much as on the intensive method where they are restricted in their range and everything bought and carried to them.

Poultry on range will go at least one-fourth mile to hunt insects, always returning to their house at night, thus making fencing on their account unnecessary.

The injury poultry will do to a crop is not serious unless too many birds are kept in one flock. The portable house should be made to accommodate not more than fifty birds each.¹ The houses should be located considerable distances apart.

Poultry are beneficial to orchards as they check the increase in parasites by destroying or devouring the bugs, slugs, and worms. Orchards attacked by winter moth were found to be almost entirely free after turning fowls in the orchard.

Strawberry patches planted on ground following wheat is often devastated with crane fly. The effect of allowing fowls to run on these tracts prior to fruit farming has been to practically clear them of that pest. The destructive raspberry beetles, which as a rule go down the stems or stalks of the berry vines toward evening or at the approach of stormy weather, are caught and devoured by the hens. Likewise the fowls devour the saw-fly caterpillars often found on gooseberry bushes.

Fowls have been found beneficial to vineyards by ridding them of parasitic life. In southwestern France poultry are used extensively for this purpose.

There is not much danger of fowls injuring most crops after the plants are 6 inches high.

CHAPTER VII

SANITATION

DISEASE is certain to appear sooner or later where a large number of birds are brought together on a limited area of ground, as in the intensive method of commercial poultry raising or production.

We might say, in general, that everything being equal that the greater the number of birds kept on any given area the sooner disease will appear.

Sanitation includes rational measures taken to prevent or delay the appearance of disease in a flock, or to limit its spread and eradicate a disease already gained foothold.

On farms where the attention and energies of the workers are directed chiefly to general crop production, and where the fowls have practically an unlimited range and only a few birds are kept, the loss may be small in spite of bad sanitation which often prevails.

Where the number of birds is large for the size of the range, as in intensive poultry culture, there can be no continued exemption from devastating epiornithics if reasonable sanitary precautions are not taken, and the successful operation of a poultry plant under such unsanitary conditions would be of short duration.

CARE OF BUILDINGS AND EQUIPMENT

The first consideration in locating poultry buildings is the selection of suitable ground with proper slope and drainage. The ground should be rolling, with good drainage, and if proper natural drainage is not present artificial drainage must be provided. The ground surface must not be uneven so that water collects or accumulates in small pools.

Birds require shade in the summer time and, if not already

provided, fruit trees may be set out, which soon grow to sufficient size to afford protection from the rays of the sun. Birds with heavy coats of downy feathers, as in ducks and geese, as well as such birds as chickens, suffer unless they are provided with water and shade in severe hot weather.

The poultry runs and buildings must be freely exposed to the sunlight. Germs of disease lurk in dark, damp quarters, and disease germs once introduced survive for a long period of time.

The soil should be rather sandy, which allows of percolation of surface water and does not become so muddy in rainy weather.

The buildings should have southern exposure to allow sunlight into the room, and should be properly ventilated. The tops, sides, and backs should be tight so as to prevent any drafts upon the birds.

Sunlight is one of the most powerful disinfectants, and the hot sun's rays are even destructive to certain young parasites. It is necessary to the health and contentment of the fowls.

In constructing the building hygienic principles must be adhered to by properly locating the doors, windows, ventilators, nests, roosts, and other parts of the building. A crack in the wall which allows a draft of air to blow onto a bird is a fruitful source for colds, bronchitis, and pneumonia and predisposes the bird to roup.

The *dropping boards* must be cleaned once or, better, twice a week. A thorough spraying of the entire house with an efficient disinfectant, as a 5 per cent. carbolic acid or a 1 per cent. kreso, zenoleum, or other equally good coal-tar disinfectant; kerosene poured on the roosts and sulphur sprinkled in the nests and the hen sprinkled with a good insecticide once every three months, the powder being worked well down into the feathers, remembering that the lice live for the most part close to the skin and are more abundant, when present, in the fluff around the vent and under the wings.

The dropping boards must not be too high, as the birds might injure themselves in jumping off the roosts. The roosts should be about 1 foot above the dropping board. The dropping board should be made in sections so it can be taken out and sunned and thoroughly sprayed with a parasiticide.

The roosts should either be removable or hinged so they can be raised and hooked up to the ceiling to facilitate cleaning the dropping boards. The roosts should not be too sharp. A 2 by 4 laid flatwise makes a good roost.

Do not allow rotten eggs and filth in the nests. Keep them clean and provide with good nesting material, as excelsior or soft straw properly arranged.

The floor of the house should be of concrete construction, and should be about 12 inches above the surrounding ground and 10 or 12 inches of cinders or crushed rock used as a base. This gives good drainage, and the floor will always remain practically dry. On the top of these cinders or crushed rock a rough and then a finish coat of cement is made. This entire cement structure should be about 3 or 4 inches thick, so that it will not break down and leave an objectionable crevice in which filth and vermin may collect. If it is not desired to go to the expense of the concrete construction, place on top of the cinders or crushed rock about 1 inch of sand and tamp down thoroughly.

Water Containers.—There are many kinds of water containers; Fig. 90 gives some good illustrations. They are sanitary in their construction.

A good practical container consists of a metal trough with cross-bars arranged on the top so the birds cannot get their feet in the water. Milk is an excellent food for young and old birds alike. Besides being a stimulant to egg production the sour milk contains lactic acid, which when taken into the digestive tract of the bird forms an unfavorable field for many of the harmful bacteria, like the *Bacillus pullorum*, causing white diarrhea in chicks, and wards off other forms of diarrhea in young and old alike. The troughs should be washed once a day with a 5 per cent. carbolic acid solution or some other equally good disinfectant.

The fronts of the houses should be made open and guarded by chicken netting and provided with muslin curtain on the inside to pull down in zero weather. This makes it necessary to have a window in each end of the house to admit light in these times when the curtain is down. The curtain being porous admits of ventilation.



FIG. 90.—A group of nine different types of commercial sanitary water containers.



FIG. 91.—A slatted crate to protect the milk-bowl.

With improvements of buildings and means of feeding with regard to hygiene we can expect more from our birds. It is necessary to keep them busy and happy, and the best way to do it is to keep them scratching in the litter for an hour or more in the morning and evening. It is necessary for a bird to have a certain amount of exercise, and this method is conducive to good egg production.

Fowls require an abundance of water at all times and consume large quantities of it, and it should be clear and clean.

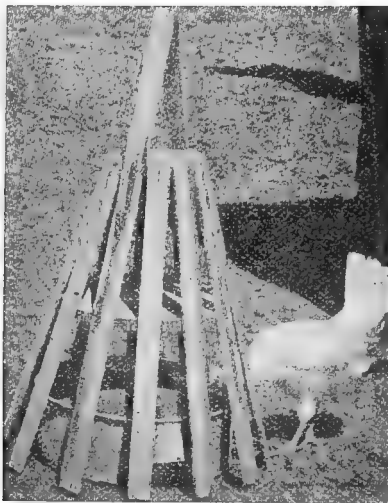

FIG. 92.—A good means of protecting the drinking water.

Eggs contain about 65 per cent. and the flesh of the fowl 60 to 80 per cent. water.

The water-troughs, protected as outlined above, prevent the birds from polluting the water by the filth from the yard they carry on their feet. The germs of many contagious diseases are eliminated from the body by way of the bowel by the excrements, and the pollution of the food and water is a fruitful source of spread of the contagion.

Contagion.—When contagion is present in the flock use intestinal antiseptics. Birds do not apparently object to the

taste of certain drugs and the mucosa of the intestinal tract tolerates certain disinfectants well. Permanganate of potash is an agent used quite extensively by poultry breeders. Place a quantity of the crystals in a fruit jar and fill the jar with water; of this solution use sufficient in the drinking-water to

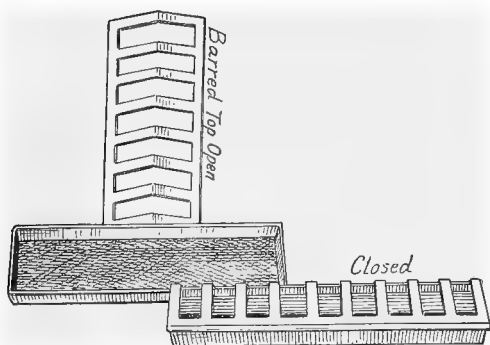

FIG. 93.—Good commercial feed- and water-troughs. The slatted top keeps the birds from getting their soiled feet in the feed.

give it a slight color. Add more water to the stock solution from time to time. Always keep an excess of the crystals or permanganate of potash in the bottom of the jar.

Disinfection is a term used to denote the process of removal of disease germs from a building and yard, and disinfection for the removal or destruction of parasites.

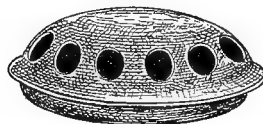

FIG. 94.—A good baby chick feed and water pan. The chicks cannot step into and soil the feed.

Disinfection must be thoroughly done. First remove all filth, from a small lump of manure behind a nest box to a single grain of dirt from the cracks in the walls, floors, or roosts, for from these may emerge the parasites or germs to reinfest or reinfest the whole building and start disease again in the flock.

If the dropping boards, roosts, and nests are removable, take them from the building, clean and thoroughly disinfect by saturating with a disinfectant, as a 5 per cent. solution of carbolic acid or 1 per cent. kreso dip, or other equally good disinfectant, and return them after they have been thoroughly scrubbed with the solution.

The roosts, dropping boards, and floor must be thoroughly scraped and thoroughly swept, as well as the walls and ceiling.

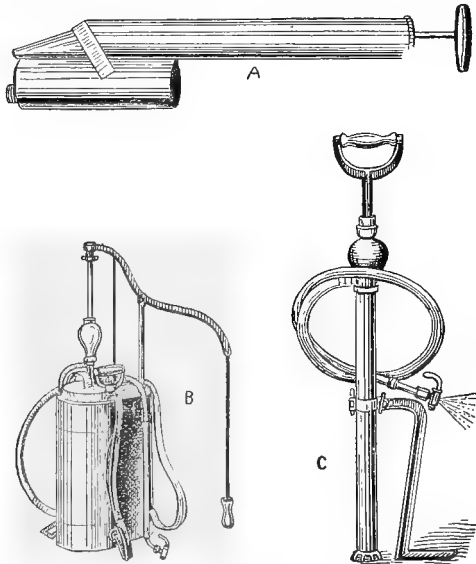

FIG. 95.—Three useful spray pumps: *A*, A small hand pump; *B*, a knapsack type; *C*, the best type force spray pump. With this pump the spray can be driven into the cracks and crevices which is necessary in successful disinfection.

The interior should be thoroughly scrubbed with a strong hot lye solution, then scrub with a 5 per cent. solution of kreso dip or other equally good disinfectant.

Gaseous disinfectants, as formaldehyd gas or sulphur fumes, cannot be used unless the house can be tightly closed. If the house be a modern open-front type or an old "shack" this procedure is impossible of any good results. In using a gas disin-

fectant, formaldehyd is more efficient for disinfectant purposes for germs, while sulphur fumes is better for ridding the premises of lice and other vermin. Certain insects, as flies, withstand the formaldehyd gas.

A complete disinfection of poultry yards and runs—that is, a destruction of all germs and vermin—is hard to accomplish.

In addition to germs and vermin there are eggs and embryos (the latter very young worms) eliminated from the bowel in

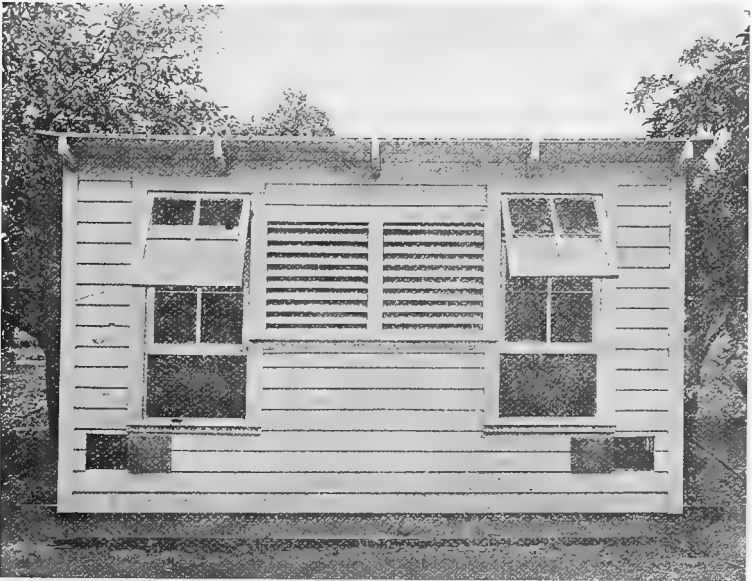

FIG. 96.—A portable poultry house. Note at *a* the sled runners, New York State Exper. Sta.

case of intestinal infestation, which contaminates the food and water and so serves to infest other birds.

It is well if the poultry house can be located on a fence-line and the birds allowed to run in one field at a time, the other field being cultivated, that is, a crop raised on it. The movable poultry houses have been advocated by some. In this type we note runners made of 2 by 8 inch oak pieces. This

serves as a foundation upon which the house rests. If a board floor is desired the floor supports rest upon these (Figs. 88, 96).

Birds need green food at all times, and oftentimes one yard can be sown in wheat, rye, clover, or rape and the birds turned on to it a few hours each day. By turning over the soil, as in cultivation, the sun's rays have a tendency to purify the ground.

Careful observations have shown that the birds will eat best rape, second clover, and last oats. The test was run by the author in which all three seeds were sown together and all a proper size when flock was turned onto it.

Beware of the yard that becomes smooth and slick and in which pools of water accumulate. If the floor of the building is too low and water accumulates and stagnates and the birds occasionally taking a drink of this polluted water, disease and death is sure to follow.

Sick Birds.—According to the rules of sanitation, we must remove the well birds from the sick, but with poultry one often finds this impracticable. So the sick bird or birds must be immediately removed from the flock, remembering that in case of contagious diseases infection may be carried to the well birds on our hands, clothing, shoes, or utensils.

As soon as you have removed a dead bird from the flock satisfy yourself as to the cause. Hold a postmortem, and if it is due to contagion proceed to disinfect as outlined above and give an antiseptic in the drinking-water.

If you are not well enough posted on the appearance of diseased organs and there is a graduate veterinarian close, take the bird to him and find out. These autopsies must be done as soon as the bird dies, for if decay or too much postmortem changes take place it will make determination of the cause of death impossible.

In performing an autopsy lay the dead bird on its back. With a sharp knife open the abdominal cavity, commencing close to the anus, passing the knife forward between the ribs and breast-bone to a point just back of the wishbone. In a like manner open the left side, being careful not to injure any of the organs in the cavities. Now grasp the sternum or breast-bone, forcing it forward, and it will break so that it will

be easy to remove it. This will lay the cavities open so that all organs can be observed without difficulty.

All birds that die, whether of a contagion or not, should be deeply buried or burned.

VICE

Egg Eating.—One of the worst vices a hen can contract is that of eating eggs. This habit is sometimes acquired by having access to an accidentally broken egg.

Hens sometimes contract the habit of eating eggs through the lack of lime or calcium. A laying hen requires a certain amount of calcium salts from which to construct the shell, and if she has a lack of this material there is evidently a craving for that sort of substance. We must concede that a bird has some natural selective powers in eating and that she does not just accidentally take up lime.

A recent case illustrates the point nicely: A flock of Single Comb Rhode Island Reds were yarded and the lime supply was neglected. The nests were placed rather low and the flock contracted the habit of eating the eggs as fast as they were laid. This condition continued for a space of about ten days. Boxes for laying were constructed higher on the walls and the birds given plenty of oyster-shell, when there was no more egg eating. There are numerous instances of this kind that could be related.

In finding that the hens are eating their eggs—First, see that the nests are high on the wall, that is, easily accessible, but at least 2 feet from the floor, and better, a run-board leading to the nest from the perch, and have the entrance of the box facing the wall; second, see that they are provided with plenty of oyster-shell, and if this does not stop it try some of the following.

An English poultryman has recommended filling a broken egg with a pure mustard paste, made by taking the ground mustard and mixing it with hot water and filling an egg-shell and allow the egg-eating hen to devour it.

The vice, at times, may be broken by giving the birds, three times a day, all the egg-shells they will eat. Usually about the third day the birds will cease eating eggs. The shells should not be broken.

Special-constructed nests have been resorted to. These boxes are provided with an inclined bottom, which allows the egg to roll down into another box just below it and so arranged that the birds cannot get at it to break and eat the eggs.

The **feather-pulling** habit is also sometimes contracted. The birds may pull out and eat its own feathers or those of its associates. The habit is most often acquired during molting time and spring time. At times it will be noted that the feathers of the reddened bare back, which is the result of molting and exposure, have been attacked and bleeding. The feather-eater prefers the young, tender, succulent feather.

Give the birds plenty of exercise by throwing their grain in deep litter. Give them plenty of green feed, also animal feed, as meat meal, and plenty of range. If only one or two birds are affected, remove them from the flock for a while.

Toe picking has been noted to develop in chicks kept confined in close quarters. Once they get a taste of blood and a fresh wound established between the toes or wing it may be difficult to break them.

Give them animal meal, green feed, and plenty of range and succulent feed. Encourage exercise by throwing grain in deep litter and requiring them to scratch for it.

PESTS

Dogs under certain conditions are known to rob hens' nests and suck the eggs. Fill an egg with tincture of capsicum. Once will do him.

The pests of the young chicks, in addition to mites and lice, are cats, rats, crows, hawks, opossum, polecats and skunks, mink, and weasles.

The baby chicks may be protected from cats by confining them in quarters wired in with 1-inch mesh chicken netting or by killing the cats. The kind of runs, illustrated elsewhere in this volume, consists of runs about 18 inches high, 2 feet wide, and 6 to 8 feet long. These runs can be made movable, so that they may be set over grassy lots as often as necessity demands.

The quarters at night must be amply provided with ventila-

tion, but must be proof against rats, skunks, and other nocturnal enemies.

Hawks and crows should be watched for and shot.

An opossum eats the head and neck of a fowl and kills one or two at a time. A mink bleeds his victims in the neck and sucks the blood, and will slaughter a dozen or two birds in a night. Both leave the carcasses of the birds in the coop.

MOLTING

Fowls should be carefully watched, and need special care and treatment during the molting period.

The process of molting is a natural one, but is a severe drain on the body.

The general condition of the fowls should be noted before the molting period comes on.

Fowls that are not too fat and that stand extra feed at the commencement of the molt do best. At times it will be noted that birds molting have a delicate appetite, and in such birds, if they are poor in flesh or overly fat, it may be regarded as a rather critical time with them.

Molting birds should have green feed. Animal food, such as meat scrap, should be supplied in the ration.

An occasional examination should be made of the birds, and if thin a more generous allowance of feed should be given.

Late molters are often caught in cold, damp weather. Under such conditions the birds must be kept in warm quarters, as having lost at least a part of their protective coat they must suffer under exposure and sickness may result.

Late hatched birds which molt late are not so profitable as early hatched and early molting birds. The molt should be over and the birds returned to laying before the high-price egg season.

Birds kept in close hot houses are noted to molt sooner than those kept in well ventilated and cool houses.

CHAPTER VIII

NON-CONTAGIOUS DISEASES

IN studying the anterior portion of the digestive tract we find a different arrangement in the organs for taking the food into the mouth than that of quadrupeds, in that there is no teeth or arrangement for masticating the food before it is swallowed. It is not at first reduced to fineness so that digestion can take place at once, but is stored and later passed along and reduced to fineness in a specially constructed organ, the gizzard.

The organs of prehension are the upper and lower mandibles or jaws, commonly known as the beak. The tongue does not play a great part in this process.

Obstruction of the beak has been observed, and is usually due to a piece of wood or other material becoming lodged cross-wise between the wings of the jaw.

Pip is an imaginary disease, as hollow tail or hollow horn of cattle. At times conditions arise where the membranes of the mouth become dried and parched and the end of the tongue perhaps suffering the greater injury. The dried end of the tongue is supposed to be a disease and some persons proceed to try to pick it off. In such conditions try and find out the cause and remove it. Moisten the mouth three times a day with glycerin and water in equal parts.

Sore mouth or **stomatitis** may be due to a fungus or low-grade mold, or it may be due to taking into the mouth irritating substances. It is also noted to accompany roup. The ulceration in the mouth in roup conditions is of a diphtheritic condition—that is, there is a considerable destruction of cellular tissue of the area of mucous membrane affected.

A saturated solution of boric acid is excellent treatment in all cases except in those of ulceration due to roup. In these cases it is necessary to scrape the ulcer with a dull knife and

touch the part with stick lunar caustic (nitrate of silver). It is dangerous to use a solution, as in that case, if it be concentrated enough to destroy the causative agent in the ulcer, it is almost certain that some of the liquid will run down onto the mucous membrane of the mouth and throat and destroy healthy tissue.

Diseases of the Crop.—Often birds are found to suffer from diseased conditions of the crop.

Gangrene is sometimes found. *Catarrh* may also be present, as well as paralysis of its walls. When food accumulates in the crop the contraction of its muscular walls forces it on through to the second portion of the esophagus as it is needed, and from there it passes into the stomach or proventriculus.

Impaction of the crop is one of the more common affections.

If the impaction is due to obstruction it may be remedied by an operation. The surgical operation is simple—lay the bird down on its side, have an attendant hold it firmly, or confine it as one would in caponizing. Pluck a few feathers from over the region of the crop. With a sharp knife make an incision about 2 inches long through both the skin and crop wall. Remove the contents of the crop and examine carefully for obstruction at the point of origin of the second portion of the esophagus. One, at times, finds small feathers, hog bristles, or other irregular bodies obstructing the passage. With a needle and white cotton thread suture the wound, passing the needle through the skin and crop wall. It is necessary to have the hands clean by washing them with soap and warm water, and to use an antiseptic, as creolin or carbolic acid, one to two teaspoonfuls to the quart of water. With a small quantity of absorbent cotton dipped into this solution the skin can be disinfected by scrubbing the site of the operation. After the operation do not feed the bird for twenty-four hours, then give a small quantity of bread and milk, the bread being thoroughly soaked in the milk.

Poisoning.—Chickens have suffered from *arsenic-poisoning* where bran has been soaked with a solution of Paris green, the bran being thrown out in the field for bait to kill grasshoppers. Chickens devouring this poisoned bran become sick and many die.

Salt brine will also kill birds.

Limber neck is a condition which is supposed to be a disease like ptomain-poisoning, caused by eating rotten or putrid meat and maggots.

Any condition paralyzing the muscles of the neck will cause the neck to become limber, and hence is commonly called "limber neck."

In limber neck give one tablespoonful of castor oil, and, in addition, give to an adult bird, three times a day, $\frac{1}{5}$ to $\frac{1}{4}$ grain of sulphate of strychnin.

Cloacitis and **colitis** are two conditions caused by infections of a non-contagious nature. This is an inflammation of the mucous membrane of the posterior bowl or rectum.

Inject a solution of carbolized oil. The mixture should consist of 10 drops of carbolic acid to each ounce of linseed oil.

CHAPTER IX

CONTAGIOUS DISEASES

THERE is a group of contagious diseases which are accompanied by diarrhea. Among these diseases we find blackhead, chicken-cholera, and white diarrhea.

BLACKHEAD

Blackhead is scientifically known as enterohepatitis, because it affects the intestines and liver.

It is called blackhead because the head is supposed to turn blue or bluish black. This is not always the case.

Blackhead affects turkeys and, more rarely, chickens. Among turkeys it causes great losses, and in some parts of the country poultrymen find turkey raising very difficult. No such reports have been made on this disease for chickens.

Blackhead affects young turkeys more than the older birds, though adult birds quite frequently are afflicted with it.

Cause.—The disease is due to a single-celled animal organism or parasite. It is necessary to magnify the germ several hundred times by aid of a microscope in order to see it. This germ was first discovered by Theobald Smith who gave it the name *Ameba meleagridis*.

The germs are found in the diseased areas of the liver and bowel, and can be seen in a slide prepared from this portion and examined under the microscope.

Thousands of these germs are given off from the area of disease in the intestine. Water or food may become soiled or polluted with droppings from the afflicted bird. Other birds become affected by eating or consuming this polluted food.

The germs on entering the digestive tract locate themselves in the blind pouches or ceca. The ceca are 5 to 7 inches long, and are located at the termination of the small intestines,

about 5 to 6 inches from the anus or external opening. The free extremity is provided with a blind sack.

The protozoa entering the epithelial cells lining these blind pouches begin to multiply, and ulceration, by destruction of the cells one by one, is the result. A turkey dead of the disease, upon being "opened up" and examined will usually be noted to have only one cecum affected. The chronic inflammation surrounding the ulcerated portion is quite apparent from the appearance of the external wall.

Later the liver becomes invaded by these germs. Upon entering the liver they cause a destruction of the cells one by one and necrotic or dead areas result. This process is slow, and first a few cells become overcome by the germs and their products and finally die. The germs continue to multiply and invade new surrounding tissue, until finally these areas of dead liver tissue may measure an inch or even more in diameter.

When the abdominal cavity of the turkey dead of the disease is opened, the liver, which occupies the lower and anterior portion of the abdominal cavity, will be noted to be affected by many areas of disease (necrotic or dead tissue), which, as a rule, is whitish yellow in color and usually rather round in shape.

As stated before, blackhead or enterohepatitis is more common in turkeys between the ages of one month and one year.

The **symptoms** are not manifested or noticeable till the disease has progressed for some length of time. The bird will first be noted to be dull, later the wings and tail appear droopy, the feathers become ruffled, and the bird sits around considerably. Later, the feathers appear ruffled and present an unkempt appearance.

Diarrhea is noted, the discharge being of a yellowish-green color. The discharge from the bowel contains myriads of the germs of the disease. It is possible that the germs may be carried on the feet of animals or birds and even man, and infect new premises, much as hog-cholera is often spread. As a rule, the animal germs, of which this is one, do not live as long outside of the body as the vegetable germs, such, for example, as blackleg in calves or chicken-cholera in birds.

The bird shows a loss of appetite and grows gradually weaker, becomes emaciated, and in from three to ten days after showing the first symptoms may die, or the disease may assume a more chronic form and extend over a period of many months.

Prevention.—It is necessary to do all possible in the way of preventative measures to stop its spread and exterminate the disease from the premises. It is possible that the disease in some cases is perpetuated and spread by a hen or even a turkey possessing great resistance, having a chronic ulcer of the bowel due to this germ, and continually gives off the germs in their droppings, making turkey raising on that farm unprofitable.

There is always a source of danger of introducing the disease in a flock or locality by a bird from an infected flock. In securing new birds make sure they are not from a flock where blackhead exists among them.

On account of their great money value, often when turkeys begin to die they are rushed off to market, as often was the case in hog-cholera before the strict interstate law, which was promulgated and put into force for the protection of the livestock industry. If they be distributed among unsuspecting breeders much harm will be done, for from the one focal center many foci of disease may thus result.

We are told that a few years ago blackhead in turkeys was a disease unknown in South Africa. Some ambitious breeder of that country imported some nice American stock, and because of the fact that this breeder in this country was unmindful of the necessity of being careful from a sanitary standpoint, and send only a stock uninfected and unexposed to contagious disease, blackhead was introduced into that country, and like this country, now possesses some portions where turkey raising is found wholly unprofitable on account of permanent infection in some poultry premises.

Disinfection should be carried out as far as possible. As the turkeys usually roost in trees, upon fences, and the tops of the smaller buildings it is very difficult to disinfect the premises.

Feed should be given from troughs, and if chickens eat with the turkeys the top of the feed hopper or troughs should be

slatted so the birds cannot get their feet into them to contaminate the feed. Water or milk should be given from a container which is likewise protected.

Treatment.—Intestinal antiseptics are indicated. Permanganate of potash may be used in the water. A good way to handle this disinfectant is to use a pint jar, place some crystals of potassium permanganate in it, and fill with water. Every time the water-troughs are refilled pour enough of this stock solution into the water to give it a slight tinge. Always keep some undissolved crystals of the potassium permanganate in the bottom of the jar. Add more of the crystals as needed, also more water as the water is used out of the jar. Sulphocarbonate of calcium, sulphocarbonate of sodium, and sulphocarbonate of zinc, equal parts, have given good results. Each bird should receive $\frac{1}{2}$ grain of this mixture three times a day. It may be dissolved and added to milk, or it may be dissolved in warm water and this water used to mix with a mash. As a mash it must be fed from long troughs, so that all birds can get to it and each get approximately their proportion.

FOWL-CHOLERA

Fowl-cholera is often called chicken-cholera. It is not due to the same germs that produce hog-cholera in hogs, nor is it similar to the germ that produces cholera in people.

Cause.—It is due to a rod-shaped germ or micro-organism, which stains at the ends with fuchsin while the middle remains unstained. It is necessary to examine a prepared and stained smear from the blood of a bird dead or ill of the disease under the microscope, and this magnified 900 to 1000 diameters before the germ is visible. It now appears as a short rod with rounded ends. The blood of a bird sick of cholera is found teeming with the germs, hence it is a septicemia.

This germ is scientifically known as the *Bacillus avisepticus*.

The discharge from the bowel of a bird sick of cholera contains millions of the germs causing the disease. Food or water becoming contaminated with the droppings of sick birds form a source of danger of spread of the disease. This contagious material may be transferred by the feet of the fowls.

Birds with the disease are usually very thirsty and stand around the water-trough much of the time.

After the bird takes the germs into its digestive tract the disease will appear in from three to seven days, depending on the resistance of the individual bird and the number of germs introduced.

Symptoms.—The onset of the disease may be so sudden that among a flock of birds which showed no symptoms of the disease the night before one or two may be dead under the roosts in the morning. If the disease is not so abrupt and severe, the bird will be noted to have a loss of appetite—that is, the bird refuses feed, but is apparently thirsty due to the high fever. The bird is very weak, often reeling as it walks. The feathers present a starchy or unkempt appearance, the bird mopes around, sits off by itself, is listless, trembling, becomes rapidly emaciated, the comb becomes dark, there is severe diarrhea, the bowel discharge being of a greenish-yellow color and very fluid. The bird sits and mopes, with tail and head down, giving it the so-called ball appearance. It may, after holding on to life, so to speak, tenaciously for seven to ten days at most, be attacked by convulsions and die.

The percentage loss is very great.

Fowl-cholera attacks chickens, turkeys, ducks, and sparrows as well as other birds.

Upon opening the abdominal cavity of a bird that has died of fowl-cholera the liver is noted to be very dark in color, tears easily, and is two or three times its normal size. The intestines are congested and contain a frothy material. There may be hemorrhage in the lining or mucous membrane of the bowel and the contents more or less blood. The spleen is large, dark, and soft. (The spleen lies in an angle formed by the posterior edge of the liver, the right side of the gizzard, and the left side of the duodenal loop. It is shaped like a horse chestnut, dark reddish in color, and about $\frac{3}{4}$ inch in diameter at its longest axis.)

The kidneys are dark, appear more or less swollen, and are soft. (The kidneys are two irregular-shaped bodies, normally dark in color and about $1\frac{1}{2}$ inches long, and lay in an irregular cavity of the backbone.)

Treatment.—Care should be taken to not spread the disease to other premises, remembering that the germs of disease may be carried on the feet of man and animals from an infected yard.

The germs may be carried in a stream of water, if it becomes polluted by yard-drainage or by throwing dead birds into it. Buzzards feasting on the dead bodies of birds that have died of cholera may distribute infection to new premises miles away. The dead birds should, by all means, be burned. However, if this is not desirable, they should be deeply buried and covered with lime.

All feed should be given in troughs. The troughs should be slatted across the top so the birds cannot get their feet into and contaminate the feed. Water should be kept in like or other equally good containers.

The hen house must be thoroughly cleaned and disinfected with a 5 per cent. carbolic acid or some other equally good disinfectant. This work must be thoroughly done or it will be entirely without results. It is very difficult to disinfect the yards. If the yards can be plowed and a crop grown upon it, the sun's rays would do much to disinfect it. The germs are very resistant and live for a long time outside the body.

Intestinal antiseptics are indicated. Use permanganate of potash, as recommended under blackhead. Also the three sulphocarbolates are valuable. Six grains of bichlorid of mercury and 3 grains of citric acid to the gallon of water make a solution 1:10,000, which is borne very well by poultry. The citric acid aids in dissolving the bichlorid of mercury. Bichlorid of mercury is slowly soluble, and it is necessary to make sure that it is all dissolved.

WHITE DIARRHEA

White diarrhea of baby chicks is a menace to the poultry raiser.

There are two forms of this disease. One form is due to a rod-shaped germ, microscopic in size, and scientifically called the *Bacillus pullorum*.

It has been determined that the ovaries of a hen producing eggs may be affected by this germ and that the eggs she pro-

duces may be infected, hence the chicks may either die in the shell or in two or three days after they hatch. The baby chicks may live longer or finally recover. Susceptible birds—that is, those capable of developing the disease—may become infected by eating food contaminated or soiled with droppings of a bird sick of the disease.

Symptoms.—The sick chicks are noted to have droopy wings, ruffled feathers, and a sleepy appearance. They huddle together and have little or no appetite. The abdominal yolk-sac is not properly absorbed. There is a discharge from the bowel, which is brownish white or white in color and which adheres more or less to the vent fluff, and the anus becomes “pasted up.”

They sit or stand around with their eyes closed part of the time and with apparently no interest in life.

They peep much of the time; when standing appear stilty and with prominent abdomen behind.

Sanitation.—It appears that late fall, winter, or early spring hatched chicks are freer from the disease than summer hatched. It would appear that hot weather furnishes a more favorable condition for the development of this disease.

Hens with a diseased condition of the ovaries are unprofitable and cease laying early in life. They are a source of the spread of white diarrhea and a menace to the poultry industry.

The common practice of late years of sending eggs for sitting from one end of the country to the other has resulted in a wider dissemination of the disease.

Baby chicks stand a 1:10,000 solution of bichlorid of mercury in water, as stated above, and in the coccidian variety is found quite beneficial.

Baby chicks should have sour milk from the start. Sour milk contains much lactic acid which, when it is taken into the intestines, forms an unfavorable field for the *Bacillus pullorum*.

Sulphocarbolates, as recommended for blackhead, has given the very best results in this condition.

Prophylactic Measures.—One of the very best methods to eradicate such diseases as white diarrhea from the flock is to mark by toe punch or otherwise all birds that have the

disease while baby chicks and sell these birds or at least keep them separate from those not suffering an attack. Breed only from those not affected while baby chicks.

TUBERCULOSIS

Tuberculosis is a disease that destroys one-tenth of the human population. Often persons become infected from the lower animals. Thus, the milk and meat from a cow suffering from tuberculosis. Likewise, pork from a hog suffering from tuberculosis may be dangerous. Likewise, a bird suffering from the disease should not be used for food.

In some localities in the United States tuberculosis in birds is rather common and is a serious menace.

In 1882 Koch, a German physician, discovered the germ of tuberculosis. It is a slender, rod-shaped organism, requiring special staining, and cannot be seen except by aid of the microscope. Chickens may become infected by being placed in quarters where infected birds have been kept or by having an infected bird introduced into the flock.

Care should be exercised not to allow any birds from an infected flock to be sold, as that is a means of the spread of the disease.

The flock should be destroyed, the premises should be thoroughly cleaned, and the building disinfected in a thorough manner. Whether the disease is eradicated from infected quarters will depend on how thorough the work of cleaning and disinfection is carried out.

Symptoms.—No absolute diagnosis can be made during life from the physical signs or symptoms. Recently a test has been made by using tuberculin similar to that used in cattle, except that the tuberculin is made from a culture of the avian or chicken variety of the *Bacillus tuberculosis*. This tuberculin is injected into the skin on the surface of the comb or wattles, and if the bird is suffering with the disease a swelling will appear in twenty-four to seventy-two hours. This is the intradermal method of diagnosing tuberculosis, and was first used successfully in testing cattle for tuberculosis. Van Es and his co-workers first used it on birds.

Upon examining a bird after it is dead various organs of the body may be found to be affected.

If the liver be afflicted it will be studded with yellowish or whitish-yellow or grayish nodules, varying from the size of a millet seed to a hazelnut. The spleen may be involved, presenting a similar appearance to that of the liver. The serous or shining membrane lining the abdominal cavity may be studded with these nodules of more or less size. The older nodules when cut through, after being removed, appear somewhat gritty, due to a deposit of lime-salts.

Birds afflicted with tuberculosis become emaciated, the comb appears pale, the bird appears dull and sleepy with no interest in life, and later dies. The bones may become tubercular, and when the joints become affected the birds may become lame.

CHICKEN-POX

Chicken-pox, or sore head, as it is often called, is a contagious disease affecting the comb and face.

Birds become infected in a similar manner as in other contagious diseases that have been discussed before.

Fall, winter, and spring bring about climatic conditions favorable to the development of the disease, hence it is more prevalent at these seasons of the year. There appears to be some relation between this disease and roup, as both occur in the same flock.

Symptoms.—The first symptoms noted will be a small nodule on the comb or face, which appears first as a so-called pimple. This gradually becomes larger. Later the top sloughs off and the part becomes sore or ulcerated.

Treatment.—Birds sick of chicken-pox should be given a tablespoonful of castor oil. If the nodule is very small, it may be treated by taking a tooth-pick dipped in pure carbolic acid and lightly touching the top of the nodule, using care lest the acid runs down onto the surrounding parts and injures that part. After twenty-four hours apply a small quantity of carbolyzed vaselin. The sores may be touched with iodine or with kerosene.

ROUP

Roup is a very highly contagious disease. It may be differentiated from common cold by the offensive odor which is not present in common colds.

Cold, damp weather, and drafts favor the development of roup.

Do not allow your birds to roost in a draft. Have the top, back, and two sides of the hen house tight.

Beware of the bird with a pale face and which frequently sneezes. Many of these birds are chronic forms of roup, and when examined closely are found to give off an offensive odor. These birds perpetuate the disease, and as soon as conditions arise which will render the balance of the flock more susceptible, the disease may spread among the balance of the flock and many birds become afflicted from the fomites of this chronic carrier.

Symptoms.—The disease manifests itself in three different forms or types—the nasal type, the eye type, and the mouth or oral type.

In the nasal type the germs invade the mucous membranes of the upper air-passage—that is, the nostrils and sinuses or cavities of the head. These membranes become swollen and are stimulated to giving off much mucous, as a person with a “cold in the head.”

The anterior opening of the nasal passage is small as compared to the cavities of the head leading to it. As a result of the drying of small particles of the mucous discharge, the opening becomes sealed and the bird is compelled to open its mouth to breathe.

In addition to this, we often find there has accumulated in the infraorbital sinus—that is, the cavity in front and below the eye—a mass of mucous, and the walls forced out forming quite a swelling in that region.

The mucous membrane of the eye likewise becomes affected, when a similar catarrhal inflammation will be noted as in the nasal form. At night, when the eye is closed, by drying of a small amount of the discharge which works its way through between the lids, the lids become adherent or stuck together,

and by the continued accumulation of the catarrhal products the lids become enormously distended.

We may find that the germs of disease have invaded areas of the mouth. These areas appear as yellowish or yellowish-white patches on the mucous membrane of the mouth. It is a diphtheritic inflammation, that is, if the membrane be torn off the part will bleed; in other words, there is a destruction of masses of cells under this membrane.

Sanitation and Treatment.—If a bird is not a valuable one it is better to destroy it.

It is well to remember that the head as well as the body must be buried deeply or, better, burned. The most of the contagion is in the head.

Thorough cleanliness and disinfection of the buildings are essential.

The germs of the disease can be carried on the hands, clothing, feeding utensils, or on the feet of animals.

Always quickly isolate the sick birds.

If it is the desire to treat the sick bird and the best results attained, it will be necessary to at first procure a syringe with strong bulb so as to force the liquid through the nasal canal.

An ordinary medicine-dropper bulb does not give force enough. Syringe out the parts with a 20 per cent. common baking soda. After a few minutes this will be found to have dissolved the mucus. Next syringe out the parts with peroxid of hydrogen and water, equal parts. This will thoroughly cleanse the parts, which are now ready for the drug calculated to destroy the germs and allay the inflammation. Inject a quantity of the following:

Oil of thyme.....	30 drops.
Oil of eucalyptus.....	20 “
Menthol.....	10 grains.
Oil of petrol.....	2 ounces.
Mix thoroughly.	

All liquids injected onto an inflamed mucous membrane should be warm.

Treat the eye in the same manner as the nasal type, and touch the ulcers in the mouth with stick nitrate of silver (lunar caustic).

CHAPTER X

EXTERNAL PARASITES

FOWLS heavily infested with any of the external parasites are unprofitable, and many kinds of external parasites, when in enormous numbers, as is often the case, cause death of the infested bird.

In order to treat birds and rid them and their premises of parasites it is essential to know something of the life history and of their habits.

Among the more common external parasite infesting birds may be mentioned lice, chiggers, air-sac mites, fleas, chicken bugs, chicken ticks, and ringworm.

LICE

Lice are a group of biting insects. Their bodies are flat and their mouth parts are arranged for biting. They live upon secretions of the body, epidermis, and feathers. The insect consists of three parts—a head, a thorax, and a body. The head is provided with jointed antennæ or feelers. In most lice of birds the antennæ are provided with five joints. The eyes are located just back of the antennæ. In some species the thorax is long and narrow, in others it is short and globular. The thorax is provided with three pair of legs. Each free extremity of the legs are provided with two bristles each, or with one or two claws, which enable them to hold onto their host. The body and legs are more or less covered with bristles.

Varieties.—Each kind of bird has its own peculiar lice, which live upon that particular kind of bird and no other. On chickens there is found quite commonly two distinct varieties. These are scientifically known as the *Menopon biseriatum* and the *Menopon pallidum*. The former is the larger of the two, and is commonly known as the large head

louse of chicks, while the latter, smaller in size, is commonly found on the bodies of the adult birds.

There is still another variety of lice which may infest chickens, but these two are by far the more common.

On turkeys there may be found two kinds. The more common variety is scientifically known as the *Gonoides stylifer*.

Ducks and geese each come in for their distinct varieties, and on the pigeon the *Lipeurus baculus* is the long slender louse, with long narrow head, thorax, and abdomen, so commonly seen in the pigeon cotes.

Description.—The female louse is a trifle larger than the male. Lice multiply or propagate by laying eggs, often called nits, which are oval in shape and white in color, and are cemented to barbs of the feathers by the female with a small amount of cement with which she is provided. In a few days, usually ten days to two weeks, depending on the temperature and other conditions, the young louse escapes from the egg by raising a small cap or piece of the egg covering. The young are lighter in color than the adults, but have about the same shape and appearance otherwise. The females are usually more numerous than the males. The lice now grow to full development and, under favorable conditions, may live for several months. During their growth to maturity they molt several times, each time taking on a slightly darker tinge.

Lice multiply very rapidly in hot weather, at which time they find conditions for existence most favorable. One pair of lice under the most favorable conditions may possibly be grandparents to over 100,000 descendants in the short space of two months.

Chicks hatched in the incubator are free from lice, and stay so until placed with lousy hens or in lousy brooders or other surroundings.

Lice live for a considerable time off the hosts (birds).

Symptoms.—Lice produce irritation, and large numbers seriously interfere with the health, growth, and development, as well as egg production and fattening processes.

A lousy bird is noted to scratch and pick at its feathers. It shows signs of being drowsy, may refuse to eat, and in growing birds the body development or growth is interfered with.

Young chicks infested by large numbers of lice sit around, mope with wings hanging down, and in a few days, usually ten days or two weeks (depending upon the abundance of lice), may die. For this reason it is the common experience that brooder chicks thrive better, grow faster, and are freer from many ailments than chicks hatched by the hen.

Lousy sitting hens may desert their nests, the comb turn dark in color. Finally, the birds, unable to rest day and night as a result of the irritation caused by the crawling, biting insects, become emaciated and die.



FIG. 97.—The proper way to dust a hen.

Parasites cause more loss to the poultryman than any one other cause, and lice as well as other biting and blood-sucking parasites may transmit or carry germs of disease from a bird suffering with a contagious disease to a healthy one.

It is not difficult to find the lice on a lousy hen. Part the feathers and the lice will be observed close to the skin and running in different directions.

More lice are found in the fluff, near the vent, and under the wings.

If the large head-lice are found upon the heads of the young chicks, it is good treatment to grease the tops of the heads with plain vaselin or lard. Care should be exercised not to apply

too much. Just a small amount is sufficient to close the breathing pores of the lice and kill them by asphyxiation.

Treatment.—The older birds are best treated by either immersing in a good coal-tar solution, as a 1 per cent. kreso dip, or by dusting with an insecticide.

A very effective insect powder is made by taking crude carbolic acid, 1 pint, and gasoline, 3 pints, mixing with sufficient plaster of Paris to make a slightly moist mixture, then run through a sieve made of a piece of common fly-screening. It will take about $2\frac{1}{2}$ pounds of the plaster of Paris. Allow the screened mixture to lay on the table on the paper where it was sieved for about two hours, when the powder will be found to be dry. It is now ready for use. If it is not used at once it must be kept in a container with a tight-fitting lid, as an old baking-powder can. It soon loses its good properties if exposed to the atmosphere. Take an old talcum can or a small baking-powder can and punch the top full of holes by aid of a nail and hammer, and use as a sifter as you use a pepper-box. (See Fig. 97 for illustration of method of holding bird and dusting.)

In applying the powder to the bird, with the left hand grasp the bird, holding it head down, dust a small quantity of the powder down into the feathers, rubbing the feathers the wrong way, working the powder down to the skin.

Dust all parts of the body. A bird thoroughly dusted need not be redusted for three months unless the houses are badly infested, under which conditions a systematic cleaning, scrubbing, and spraying with a strong coal-tar disinfectant, as a 2 per cent. creolin solution, must be carried out.

Dust all hens at time of setting, and again the day they are taken from the nests.

CHIGGER

Another troublesome parasite is the chigger.

Description.—This parasite is scientifically known as the *Trombidium holosericeum* and is minute in size, and hence commonly known as the chicken mite. It varies in size up to half the size of a common pin-head. Its body is oval in shape, and varies from a light-yellow tinge in the young state

to a bluish-red color in the adult state. Its head parts consist of a conic-shaped piercing apparatus, with which it pierces the skin and sucks serum or blood. The free extremity of the last segment of the legs are provided with hooklets or claws which enables it to hold onto its host.

The mite lays its eggs in cracks and crevices and filth of the hen house. If the weather is warm the eggs hatch in a few days into a larva, which is asexual and is provided with three pair of legs. In the course of a very few days it goes through stages of molting and finally reaches the sexually mature eight-legged stage.

In hot weather, as in July and August, mites multiply very rapidly, and I have seen thousands upon a single hen, causing death of the infested bird.

Symptoms.—Thousands of mites crawling and biting and sucking blood cause an anemia or loss of blood and emaciation. The bird cannot rest day or night and finally succumbs to the ravages of the parasites. Sitting hens leave their nests, laying hens cease to lay, and such birds may be found dead under the roosts in the morning, succumbing during the night.

Often under such conditions, if the roosts are taken out in the sunlight, the cracks and crevices may be seen fairly alive with the acari.

Treatment.—Pour kerosene or gasoline on the roosts. Gasoline is a mild disinfectant and a powerful parasiticide or destroyer of parasites.

Dust the hens with the insect powder described before, thoroughly clean the hen house, thoroughly scrub and spray every square inch to saturation, reaching all cracks and crevices with a 2 per cent. solution of creolin, kreso dip, zenoleum, or some other equally good coal-tar preparation.

Fumigation with sulphur fumes is effective, provided you have a thoroughly tight building, but it is practically useless unless the building can be tightly sealed as for fumigation, as practised by health boards in disinfecting rooms of dwellings following contagious diseases. Therefore, our advice is to rely on the liquid solutions and insect powder.

If the weather is hot, the hen may be dipped in a 2 per cent. solution of some good coal-tar product, as zenoleum or creolin.

SCALY LEGS

There is a common condition in some localities called scaly legs, so called because the legs have accumulated upon them scales or scabs.

This is one form of scabies that is caused by a parasite belonging to the same family and genus as the one commonly causing scabies or mange in the horse and dog. It is scientifically known as the *Sarcoptes mutans*, variety *gallinæ*. It is minute in size and scarcely larger than the point of a pin.

Description.—The parasite infests the shanks or unfeathered portion of the legs only—that is, from the hocks down to and including the dorsal and lateral sides of the toes. The parasite is oval in shape with mouth parts arranged for cutting the skin. It lives on the serum that exudes from the injured part. The parasites burrow between and gradually work their way under the edge of the scale, where by their irritation a small amount of serum exudes, which dries and which particle contributes to the formation of a larger scab. The scaly leg parasite multiplies by laying its eggs in galleries in the skin, where they hatch out in the course of a few days, usually about ten, into an asexual six-legged minute parasite. The young parasite is practically invisible to the unaided eye. After going through several molts it arrives at the fully developed or adult state, and is now provided with reproductive organs and eight pair of legs and ready to again repeat its life cycle. These scab parasites develop very fast in warm weather. By increasing numbers and continuous irritation by their presence and biting, dried serum accumulates to such an extent that the scales of the legs become forced up out of a normal level. Finally, the legs appear with more or less large masses of hard crusts or scales. By removing these scales it will be noted that the undersurface is moist. In this moisture may be observed minute light-colored specks, almost pin-point in size, and when removed by aid of the point of a needle or pin and placed under a low-power magnifying lens they may be noted to move about.

These scab parasites, while they go through their entire life cycle on the legs of the host, yet they will live for several days off the host.

Spread.—Birds become infested by coming in contact with other birds with scaly legs, or by being placed in shipping coops or placed in buildings or runs in which birds with scaly legs have been kept.

No birds should be sold for breeding purposes from a flock with scaly legs, nor should such birds be exhibited in the show-room or shipped in crates breeding stock is to be shipped in.

Treatment.—In treating a bird with scaly legs, first soak the scabs with warm water, then with a nail-brush remove by scrubbing all scabs possible to be removed. Scrape with a dull knife, then after the legs have dried saturate them with kerosene. Kerosene penetrates deeper than watery solutions and is a powerful parasiticide or parasite destroyer. Repeat this treatment once every five days for several applications. A hot solution of lime and sulphur dip, as used in sheep dipping, has been used with excellent results.

Thorough eradication from an infested quarter is difficult. The greatest number of parasites off the bird will probably be found in the nests and on the roosts, and disinfestation of these and other parts should be looked to as under lice.

CHAPTER XI

INTERNAL PARASITES

BIRDS at times are infested by many different varieties of worms.

Among these common worms may be mentioned several groups, as the tapeworms and round-worms of the intestinal tract, and the round-worm of the trachea or windpipe, the gape worm. In addition to these there is found more rarely the flukes and the thorn-headed worms.

If only a few intestinal parasites are present there may be no perceptible harm noted in the infested bird.

Death of any bird from the effects of internal parasites should be looked upon with apprehension.

Devastating epizootics from intestinal parasitism are recorded.

ROUND-WORMS

The most common internal parasites are the round-worms. The round-worms are cylindric in shape, tapering slightly toward the head, and some varieties markedly at the posterior third. They are white to pinkish white in color. There are two distinct sexes, a male and female, the females being the larger.

Intestinal round-worms multiply by producing eggs which pass out to the ground with the droppings. The eggs are microscopic in size and oval in shape.

Transmission.—Water and food become soiled with the excreta laden with the eggs, and thus other birds consuming contaminated food become infested.

It is advisable in killing birds for food purposes to examine the intestinal content for worms. The intestine is easily opened by using a sharp, slender-pointed knife. If worms be found, the flock should be medicated in an effort to rid the birds of the parasites.

Worms, when in considerable numbers, rob their host of considerable food nutrients. They consume by taking into their digestive tract the nutrients which ought to be absorbed by the capillaries of the intestinal wall. They interfere with digestion, and by their presence cause irritation of the mucous lining of the bowel. Diarrhea often results, which persists and causes large losses in large flocks of birds. Sometimes the worms accumulate in such large numbers that the lumen or passage of the intestines is in part or wholly obstructed.

LARGE ROUND-WORMS

The **large round-worm** is called the *Ascaris inflexa*. It is present in over 25 per cent. of the birds purchased on the market. It is round in shape and whitish yellow in color and varies from 1 to 2 inches in length.

This worm, when present, is found in the small intestines. Its body is rather rigid, but when the live worm is taken from the intestine and placed in water that is rather cold, vigorous contractile movements are noted due to the stimulus caused by the cold water.

It has been determined that these and other intestinal parasites are poisonous. The excrementitious or waste matter given off from the body of the worms is absorbed by the host, and when the worms are present in large numbers and the toxic or poisonous substance is considerable in quantity there will be noted constitutional effects in the bird.

Symptoms.—Large numbers may cause a partial loss of appetite, unthrifty condition, unkempt appearance of the plumage; the birds appear dull and sluggish with droopy wings, there is a loss of appetite; the bird becomes poor in flesh and even emaciated. The comb and face no longer appear red, but pale or a bluish tinge, and in a few weeks at most the bird may die.

By observing the droppings closely one finds an index to the digestive conditions. In intestinal parasitism an occasional worm will be passed.

This worm belongs to the same family (that of *Ascaridæ*) as the round-worms of the small intestines of the horse, hog, and cat.

Treatment.—In way of treatment it is found necessary to keep the yard and hen house clean. The drinking water for the birds should be kept in fountains and no depressions allowed about the yard for the accumulation of small pools of rain water. The feed should be given from clean troughs, made for the purpose, and disinfected daily by scrubbing with a 5 per cent. solution of carbolic acid or other equally good disinfectant. All troughs should be so constructed that the birds cannot step in them. (See Figs. 90, 93, and 94.)

Fast the birds twenty-four hours, and then give each bird one teaspoonful of olive oil and one teaspoonful of turpentine.

If the flock be large and it is the desire to make an effort to treat the birds by giving the agent in the feed, the following plan may be tried: Fast the bird twenty-four hours, then mix with shorts and water 2 grains areca nut for each bird, making the mixture about the consistency of batter. Pour the mixture in a trough, so that all the birds can get to the feed at the same time and each bird obtain its proportionate amount.

Areca nut is not only a parasiticide, that is, kills the parasite or worm, but an irritant to the mucous membrane lining the bowel, and hence a cathartic or physic, causing the expulsion of the worm.

One-grain doses of thymol is excellent treatment. This must be followed by a physic of salts or oil.

SMALL ROUND-WORMS

There is a small round-worm, whitish in color and from $\frac{1}{4}$ to $\frac{1}{2}$ inch in length, which infests the ceca or blind pouches of the intestines of the chicken. This worm in many localities of the United States is found in 50 per cent. of the birds examined.

If the bird be infested by large numbers of worms, similar conditions are noted as produced by the larger round-worm.

As to **treatment**, it will be found somewhat more difficult to rid the intestinal tract on account of the anatomic arrangement of the ceca.

Best results will probably be attained by giving santonin, areca nut, or thymol as for the larger worm, as stated before.

GIZZARD WORM

Another worm, scientifically called the *Spiroptera hamulosa*, and commonly known as the gizzard worm, has been known to cause great losses among chickens. It is a round-worm, with rather blunt extremities, and measures about $\frac{3}{4}$ inch in length. It inhabits the walls of the gizzard.

Symptoms.—Birds so infested have been noted to grow lazy or languid, pale comb, face, and wattles; emaciation, ravenous appetite, and finally the bird dies. The worms are found coiled in small nodules in the walls of the gizzard and are readily seen in making an examination of the bird after death.

Treatment.—Similar treatment is indicated as in other forms of intestinal round-worms. On account of the fact that the worms are embedded in the lining of the gizzard it is rather difficult for any drug to reach them, and treatment has resulted rather unsatisfactory. It is better to slaughter all birds of an infected flock and thoroughly disinfect as for chicken-cholera, and move the location of the poultry house and run if it is possible to do so and to start over with a new flock. Do not sell them where they will be used for other flocks, as that will tend to spread the contagion. No birds should be kept in the infested quarters till at least one year has elapsed from the time of disinfection and thorough cleaning of the house and runs. Unless this cleaning is carried out in the minutest detail it will be of no avail. A piece of dropping the size of a pea may contain the embryo and serve to again introduce the contagion into the flock.

GAPE-WORM

This is a worm which, when it gains a foothold, may prove a scourge to the chick industry. This worm is commonly known as the gape-worm, and scientifically called the *Syngamus trachealis*.

The female reaches an inch or a trifle more in length. It is round in shape, tapering at the posterior extremity. Its head parts are provided with circular, chitinous, capsular mouth parts, by which means it holds tenaciously to the mucous membrane lining the trachea or windpipe of the young chick. The

male is very much smaller, being only from a third to one-half as thick as the female and scarcely more than $\frac{1}{4}$ inch in length.

The male is always attached to the female at the upper third, so that the worms appear as one individual and forked, but in reality are two—a male and a female. Both hold onto the mucous membrane of the trachea, and by means of membranous or chitinous teeth wound the mucous membrane and suck blood from their host.

Reproduction is brought about by the female worm developing eggs which are oval in shape, and which do not pass from the body of the female in which they develop till the worm is expelled from the trachea and the body degenerates. These eggs are then taken up by earth-worms. These infested earth-worms in turn may be eaten by the young chick, and thus the chick becomes infested with the microscopic embryos or minute worms. As soon as the embryos or minute worms enter the digestive tract of the chick they penetrate the wall and locate themselves, by selection by preference, in the trachea. If there be many of these worms they form a cluster, and as the worms grow they gradually occlude or obstruct the air-passage, and finally the chick, finding it difficult to get sufficient air into the lungs, gasps for air, throwing its head high into the air by extending its head upward, finally back over the dorsal part of the body, falls backward, and dies from asphyxiation, as one strangled by drawing a cord tight around the neck. The condition produced is called *gapes*, because the chick gasps or “gaps” for air.

Chickens, turkeys, ducks, geese, pheasants, partridges, peafowls, magpies, black storks, starlings, crows, parrots, swifts, woodpeckers, and martins have all been reported as being from time to time afflicted by this worm or parasite.

Treatment.—The worms are usually lodged in a mass or lump in the trachea, which may be felt as a “lump” by the thumb and forefinger.

Gently grasp the bird in the left hand and force its mouth open, using the thumb and forefinger, and insert into the trachea a doubled horse-hair, or take a feather and strip off all barbs except a few on the tip, dip this in turpentine, pass it down the trachea till the tip barbs left on are below the mass,

twist the feather and withdraw. The mass will usually be dislodged, and if not drawn out will be expelled by the bird sneezing.

As a precautionary or prophylactic measure it is well to feed only from containers constructed for the purpose and which can be kept clean. (See Figs. 91, 92, 93, and 94.)

Do not allow the chicks to run on wet ground where they are likely to find earth-worms. Keep them on a board or concrete floor.

TAPEWORMS

There is a group of worms that are flat and ribbon shaped. They are commonly called tapeworms. There are several varieties which infest the intestinal tract of most animals, including man, horse, cow, dog, cat, rat, fish, and poultry.

Description.—The tapeworm is provided with a head, a neck, and a body. The head is provided with a fixation apparatus—that is, a means of holding on. This apparatus consists of four sucker disks and hooklets. These hooklets are very small in size; they are, in fact, seen only by aid of the microscope. By means of this fixation apparatus it holds on to the mucous membrane lining the intestines and floats back in its content. The entire head is scarcely as large as the head of a pin. The neck in most species infesting the intestinal tract of birds is short and thick. The body varies in length according to the species of worm. The body is flat or ribbon shaped and consists of a chain of segments. In some species the segments close to the head are very narrow and short. As the distance from the head grows greater, the segments become wider and longer. There are no distinct males and females as in round-worms. The first segments close to the neck are not provided with generative or reproductive organs, but as the distance from the head grows greater, or as the segments grow and develop, they finally develop the generative organs, and the segment is spoken of by parasitologists as being mature, and, like plants, self-fertilization takes place, being now provided with both male and female generative organs fertilizes itself. After fertilization each segment develops many hundreds of eggs. After all these eggs are mature

or fully developed they are spoken of as being ripe. The ripe segments detach themselves, sometimes one, and at other times two, three, or even four. These segments, laden with mature eggs by the thousand, pass out to the ground with the droppings. The eggs they contain are microscopic in size and oval in shape. Other birds partaking of food or water contaminated or soiled by the infested droppings may become infested.

Symptoms.—The tapeworm has no digestive tract as is the case with the round-worm. They live by each segment absorbing its own food. This food consists of nutrients taken into the digestive tract of the host and digested. Hence, when large numbers of these worms are present they absorb much valuable digested nutrients, thus robbing the host. The birds become thin in flesh and, in fact, emaciated. There may be a loss of appetite, an unthrifty appearance, the feathers present an unkempt appearance, and the bird finally dies.

One or more ripe segments may be shed at one time, which appear on the outer edge of the droppings as a whitish body. If these segments be placed in cold water as soon as passed they will be noted to possess the power of contractility or slight movement, that is, contraction and expansion.

Treatment.—Fast the birds twenty-four hours and give a teaspoonful of turpentine and a tablespoonful of epsom salts. Dissolve the salts in hot water.

A few teaspoonfuls of a decoction of pumpkin seed, followed by a physic of salts, is good treatment.

If it is the desire to avoid medicating each bird separately and take chances on collective treatment, give in a mash made of wheat shorts mixed with water 2 grains of powdered areca nut to each bird, as suggested under round-worms.

CHAPTER XII

THE FEED PROBLEM

FEEDING is one of the most paramount questions to the poultry raiser. He is ever confronted with the problem of the best results at the lowest possible cost. Therefore, feeding poultry to attain the best results for the purpose for which they are fed must be considered from a purely scientific standpoint.

It is not sufficient to know that certain substances possess great nutritive value, and that certain feeds are practically worthless or are of low nutritive value, but he must know what feeds are best suited to the varying conditions of the animal economy for the purpose for which it is being fed.

PLANT GROWTH

A microscopic examination of a blade of grass, grain of wheat, or stalk of corn shows it to be made up of cells variously modified: the whole group of cells taking on the form of the object under consideration. It has been determined that primarily all cells are closed sacs, which contain the juices and other substances incident to plant life which parallel animal tissue. A woody substance, known as cellulose, forms the cell wall. If the plant is supplied with an abundance of water and other favorable conditions, the growth is rapid, the cells are large, and the walls are tender, as in young rape, and the birds eat it with a relish. This kind of feed ranks high in albuminous material. The growth may be slower, as in the stems of the forest trees, whose cells are found to be small, hence a large amount of cellulose and the parts are tough and woody.

Certain elements are necessary to plant life. These are carbon (C), hydrogen (H), oxygen (O), nitrogen (N), and ash or mineral matter.

The hydrogen and oxygen may be taken up in the form of water (H₂O). Half-grown clover has been found to contain as much as 90 per cent. water. The water taken up through the roots carrying mineral matter and other plant nutrients in solution is known as sap, and flows from the roots to the leaves, where the excess is given off as watery vapor. Analysis and study has shown that wheat, beans, and clover may exhale two hundred times their dry weight of water during five months of their growth.

Carbon dioxid (CO₂) is taken in through minute openings in the leaves. Through the decomposition of the water and carbon dioxid and a rearrangement of their elements in the plant, starch is formed with an excess of oxygen which is exhaled through the leaves. Thus, the plant utilizes carbon dioxid, a poisonous gas given off from the lungs of animals, and gives off in return oxygen, which oxygen is necessary for the support of animal life. It may be said, therefore, that plants support animal life and that animal life supports plant life. This starch is the foundation of one of the principal groups of food nutrients needed in poultry feeding—namely, the carbohydrates. One molecule of starch may be converted into a molecule of cane-sugar by the addition of a molecule of water, thus:



Cane-sugar may be converted into glucose, another form of sugar, by the addition of another molecule of water, thus:

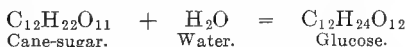

Therefore, sugars and starches form the carbohydrate group. It is noted that in the carbohydrates the hydrogen is always twice the quantity of oxygen content.

A molecule is composed of atoms. A molecule of starch is made up of 42 atoms—that is, 12 atoms of carbon (C₁₂), 20 atoms of hydrogen (H₂₀), and 10 atoms of oxygen (O₁₀). By the addition of 2 atoms of hydrogen and 1 atom of oxygen the starch is converted into cane-sugar, as illustrated above.

Fats and oils form another plant material and which contains the same elements that compose starch—namely, carbon

(C), hydrogen (H), and oxygen (O), but the hydrogen is not exactly twice the quantity the oxygen. Thus, the formula of an animal fat, stearin, is $C_{57}H_{110}O_6$, of palmatin $C_{51}H_{98}O_6$, and of olein $C_{57}H_{104}O_6$.

The fats and oils constitute a second group of food nutrients called hydrocarbons.

A third food nutrient is the protein group. Nitrates are taken up in solution by the roots of the plant which, upon reaching the protoplasmic masses in the active plant cell, nitric acid and sulphur, are united with starch or a starch derivative forming a protein compound. Protein is the nitrogen-containing food nutrient, and contains carbon (C), hydrogen (H), oxygen (O), nitrogen (N), and sulphur (S), the chemical formula being as follows, $C_{12}H_9O_{22}N_{16}S_1$.

Vegetable albumins closely resemble the white of eggs. It is coagulated by heat. The albuminoid in wheat is called gluten. These three groups of food nutrients—namely, carbohydrates, hydrocarbons, and protein—constitute the organic portion of the food.

Plants contain mineral matter which has been taken up in solution during plant growth through the roots and deposited in the plant tissues. Ash and water constitute the inorganic nutrients of vegetable food.

Organic matter is destroyed by fire. Inorganic matter cannot be destroyed by fire, though its form may be changed. Thus the water during burning of foodstuffs is changed in form, but not destroyed. It enters the air as vapor, but becomes liquid again under favorable conditions, whereas the protein burned is destroyed.

The hydrocarbons or fats and oils are sometimes spoken of as ether extract, because in analysis of foodstuffs they are extracted by ether. Cellulose, an insoluble starch, the coarser particles of feed, is spoken of as crude fiber. It is classed with starch.

The nitrogen-free extract belongs to the carbohydrate group.

To summarize: The carbohydrate group includes the following nutrients—starches, sugars, gums, and resins. The hydrocarbon group—fats and oils. The protein group—the nitrogen-containing food nutrients.

When these groups of nutrients are taken into the body of the bird they are converted from vegetable tissue or substance into animal tissue through digestion, absorption, and assimilation. This process we know as the process of nutrition.

DISTRIBUTION OF THE BIOELEMENTS (FROM HACKH)

Element	Per cent. in mammal	Per cent. in carbo- hydrate	Per cent. in fat	Per cent. in protein	Per cent. in fresh water
O.....	62.430	49.38	17.90	22.40	88.800
C.....	21.150	44.44	69.05	51.30	0.005
H.....	9.860	6.18	10.00	6.90	11.160
N.....	3.100	0.00	0.61	17.80	0.002
Ca.....	1.900	0.00	0.00	0.00	0.004
P.....	0.950	0.00	2.13	0.70	0.001
K.....	0.230	0.00	0.00	0.00	0.001
S.....	0.160	0.00	0.31	0.80	0.018
Cl.....	0.080	0.00	0.00	0.00	0.000
Na.....	0.080	0.00	0.00	0.00	0.001
Mg.....	0.027	0.00	0.00	0.00	0.003
I.....	0.014	0.00	0.00	0.00	Remainder
F.....	0.009	0.00	0.00	0.00	0.000
Fe.....	0.005	0.00	0.00	0.01	0.002
Br.....	0.002	0.00	0.00	0.00	0.000
Al.....	0.001	0.00	0.00	0.00	0.000
Si.....	0.001	0.00	0.00	0.00	0.000
Mn.....	0.001	0.00	0.00	0.00	0.000
	100.000	100.00	100.00	100.00	100.000

THE PHYSIOLOGY OF DIGESTION

Digestion in the fowl is rapid. Experiments show that food will pass through the intestinal tract of a 2-pound chick in about three hours, of a laying hen in three hours and in a hen not laying in about eight hours and in a sitting hen in fourteen hours. All test material had passed through the intestines by the end of seventy-two hours. All tests were run on an empty crop.

The food is taken in by the bird by its prehensile organs, which passes through the first portion of the esophagus to the crop or ingluvius (Fig. 98, letters *a*, *b*¹, and *b*²).

The **crop** is a storehouse for the food during the hours of foraging. From here it is forced out as needed by aid of its muscular walls, which forces it into the second portion of the esophagus to the proventriculus or true stomach (*d*).

The **proventriculus** is provided with glands located in its walls which secrete a gastric or stomach juice in which the food soaks before it passes into the gizzard (*e*). The reaction of the stomach contents is acid; this acidity depends upon hydrochloric and lactic acids secreted by the cells located in the stomach walls.

Gastric juice is a thin, transparent, watery fluid which is acid in reaction. It contains enzymes and acids. Its chief ferment is pepsin. Pepsin, like other ferments, belongs to the proteid group. This ferment in the presence of acids acts upon the protein group of food nutrients. In this action insoluble proteins are converted into soluble forms for absorption into the blood through the blood capillaries. In this change the protein is converted first into syntonin, then into primary, and next into secondary proteoses, and last into soluble peptones.

The **gizzard** is an organ which is to the bird what the molar teeth are to solipeds. It is here by aid of grit and the contraction of its powerful muscular walls that the feed is reduced to fineness so that the digestible nutrients may be digested—that is, rendered into solution and utilized by the body. It will be noted that the opening into the gizzard from the proventriculus is close to the outlet from the gizzard into the small intestines (Fig. 98, letters *d*, *e*, and *f*).

The Pancreas.—The first portion of the small intestines forms a loop in which lays a whitish-yellow elongated gland, the pancreas (*f*). The pancreas secretes the pancreatic juice which performs certain important functions in digestion. It is very difficult to obtain pancreatic fluid in a pure state, but it is probable that it has the same function in digestion in the small intestines of the fowl that it has in other granivorous animals. The pancreatic fluid is alkaline in reaction, and is a clear, colorless fluid resembling water. It possesses an unpleasant saltish taste, and has a specific gravity of from 1010 to 1030. On analysis it has been found to contain 98.25 per

cent. water and 1.74 per cent. solids, of which 0.88 parts are organic matter, containing 0.86 parts of ferment. The remaining 0.86 parts are salts, which include considerable so-

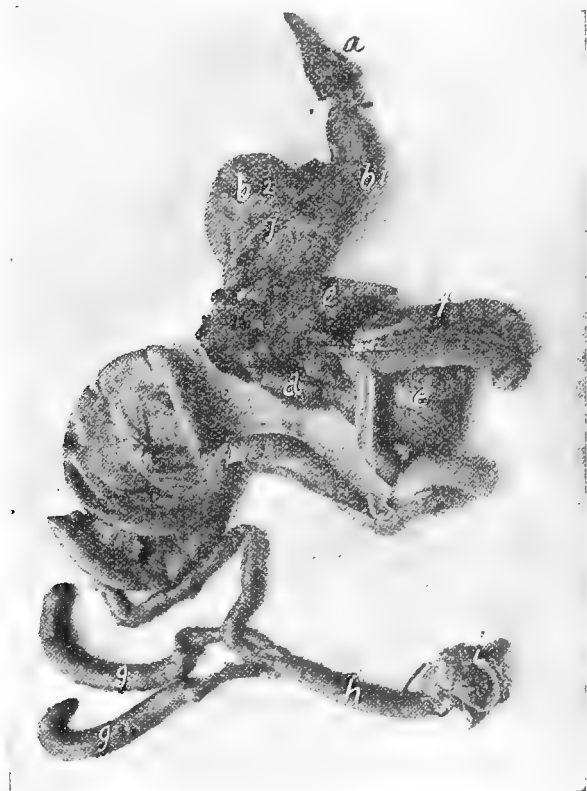

FIG. 98.—A photograph of the organs of digestion and respiration: *a*, Tongue; *b*¹, first portion of the esophagus; *b*², the crop; *c*, the liver, showing the gall-bladder just below the *c*; *d*, the proventriculus; *e*, the gizzard; *f*, the duodenal fold the first portion of the small intestines between which may be seen the pancreas; *g*, the ceca; *h*, the rectum or large intestines; *i*, the anus—the expansion just back of the anus is the cloaca; *j*, the trachea or "windpipe;" *k*, the lungs. The spleen is the oval body just above the letter *d*.

dium phosphate, chlorid, potassium, carbonate, and calcium, also small quantities of magnesium phosphate.

The reaction of the stomach or proventriculus contents is strongly acid, likewise the same holds good of the gizzard. The reaction of the contents of the duodenum or first portion of the small intestines is weakly acid; of the latter part of the small intestines, faintly acid, neutral, or faintly alkaline. The same holds good for the ceca. The reaction of the large intestine or rectum is alkaline.

The pancreatic secretion is influenced by special secretory nerves. The food, after undergoing a reduction to fineness in the gizzard, is poured out into the duodenum or first portion of the small intestines. The wall of the intestine is lined by a mucous membrane which is provided with secreting tubular glands. Certain cells of these glands secrete a substance known as an internal secretion which, when absorbed, causes a stimulation of the pancreatic cells to activity and the pancreatic fluid is poured out into the small intestines.

The pancreatic secretion is one of the essential digestive fluids. It acts upon all three organic groups of food nutrients. Its three enzymes and their action are as follows:

Trypsin, a proteolytic enzyme which acts upon proteids (protein).

Steapsin (lipase), a lipolytic enzyme which acts upon fats (hydrocarbons).

Amylopsin, a diastatic enzyme which acts upon the carbohydrates (starches, sugars).

The proportion of these ferments apparently vary with the character of the food taken in by the fowl. If the food consumed is rich in starch, the secretion will be rich in diastatic ferment; if protein, then rich in proteolytic enzyme.

The *trypsin*, as it comes from the pancreas, contains a substance called trypsinogen, which is a precursor of trypsin; another substance is secreted by the cells of the glands of the small intestine and is called enterokinase. This enterokinase acts upon the trypsinogen converting it into trypsin. The trypsin is apparently the only one of the three ferments that is secreted in an inactive state and necessitates being activated.

All foodstuffs must be reduced to a more simpler form than they appear in vegetable and animal tissues. As seen under the discussion above, the protein molecule is complex. Tryp-

sin splits it into simpler products which places it in a form readily absorbable. In other words, the protein of wheat, corn, and meat-scrap have to be reconstructed in order to form a part of the tissue of the fowl.

The function of the trypsin in the small intestine is to break down these protein molecules into a number of simpler bodies of less molecular weight.

Protein is converted into albumose and peptone, carrying the splitting-up process to the formation of end-products, as amido-acids, tyrosin, and leucin, glutaminic acid, aspartic acids, tryptophan, hexone bases, lysin, arginin, and histidin.

There is still another ferment found in the intestines and which is secreted by the glands of the intestinal mucous membrane. This secretion is called *erepsin*, and is capable of acting on any protein escaping the action of the gastric or pancreatic ferments. It is capable of splitting peptones and albumoses into tyrosin and leucin.

The lipolytic ferment, *steapsin*, is the ferment which splits the neutral fats into fatty acids and glycerin. The liberated fatty acids unite with the alkaline bases of the bile and soaps and glycerin are formed. In this emulsification process the oil globules are rendered very small, which do not again coalesce, and are then further split up, as indicated above. Through the lacteals the fats are absorbed as soaps and glycerin, where the lipase may reunite them back into fat; therefore lipase has a reversible action.

A diastatic ferment, known as *amylapsin*, acts upon the starch, finally splitting it into maltose and achroödextrin; these are then by the maltase of the succus entericus, or secretion from certain cells of the glands of the intestinal mucous membrane, converted into dextrose, in which form it is taken up by the capillaries of the intestinal mucous membrane.

The liver, like the pancreas, is an accessory organ of digestion. (See Fig. 98, letter c.)

From an anatomic standpoint the liver differs from other organs in that it is provided with two blood-supplies: (1) The nutrient blood which furnishes nutrients to the cells of the organ, and (2) a functional blood-supply from which it obtains certain substances to act upon.

The absorbing vessels from the intestines enter the liver and is included in the functional blood.

Bile possesses a bitter taste, is dark green in color, alkaline in reaction, rather thick, with a specific gravity of over 1020.

The color of bile depends on the kind and quantity of pigment present. The liver of the fowl is provided with a gall-bladder, which adds a rather viscid-like mucous secretion to the bile being stored, making the gall from the bladder more viscid and heavier in specific gravity than that from the bile-ducts. This is due to the fact that solids are added to it from the walls of the bladder.

The bile does not contain ferments, as does the pancreas.

Bile contains biliary acids, fats, soaps, biliary pigments, cholesterin, lecithin, and inorganic salts.

On analysis of the bile there is found carbon dioxid and traces of nitrogen and oxygen, together with sulphur, phosphates, and chlorid of sodium and salts of calcium, iron, magnesium, and potassium. There is also present sulphuric and phosphoric acids. The larger proportion of salt is sodium. The phosphate of iron content is probably derived from hemoglobin of the broken-down and worn-out red blood-cells.

The percentage of water varies from 88.8 per cent. to 95 per cent. The inorganic constituents (salts) form 0.6 per cent. to 1.3 per cent. The organic constituents (bile acids, bile-pigment, fat, and mucin) vary from 4.1 to 10.1 per cent.

The *cholesterin*, a product of cell metabolism, is eliminated by the liver. It forms the principal constituent of gall-stones. In the bile it is held in solution by aid of the bile salts.

Another waste product of the body is *lecithin*, which is excreted by the liver and eliminated with the bile.

There are two pigments—namely, *bilirubin* and *biliverdin*. *Biliverdin* is oxidized bilirubin. These pigments give color to the bile. The pigments are insoluble in water, but soluble in alkalies. They are held in solution in the bile by aid of the alkalies and bile acids.

There are two bile salts—namely, *taurocholate* and *glycocholate of soda*. Taurocholate of soda is formed in the liver by the union of taurine and cholalic acid, and glycocholate by the union of glycine with cholalic acid; they exist in combination

with soda, in which combination they are known as glycocholate of soda and taurocholate of soda.

These salts are alkaline in reaction and soluble in water.

During intervals of active duodenal digestion the bile is stored in the gall-bladder and is poured out into the lumen of the duodenal fold during active digestion in that part. It is presumed that the acid material coming from the gizzard into the duodenum stimulates the contraction of the bladder walls, forcing its contents into the intestine.

Bile does not perform a function of digestion, as does the ferments of the gastric and pancreatic juices.

The bile, being alkaline in reaction, gradually overcomes the acidity of the material poured into it, neutralizing it. It precipitates the peptones and albuminose. Bile acids aid in the emulsification of the fats and is active in the presence of pancreatic juice. It does not, like the pancreas, split up fats into fatty acids and glycerin. The bile salts are decomposed in the presence of free fatty acids, their soda set free, and thus soaps are formed. The soap aids in rendering the emulsifying effects of the bile permanent, thus facilitating the absorption of fats.

That bile facilitates the passage of the digested fats is demonstrated by experiments with animal membrane, the membrane being moistened with bile readily giving passage to emulsified fats.

In examining the organs of the fowl it will be found that the liver is decidedly the largest gland in the body, and we find its functions are many. The liver manufactures and stores up in the cells a substance known as glycogen, which is an animal starch. While termed animal starch, it differs from vegetable starch in that it is soluble in cold water, whereas vegetable starch is not. It stains reddish brown by iodine, whereas vegetable starch turns blue.

The carbohydrates of the food (starch and sugars) digested in the intestines is absorbed by capillaries located in the mucous lining of the intestine, thence carried by the portal vein to the liver, where through the activity of the cytoplasm of the liver cells it is converted into and stored up as glycogen. It is now doled out as needed through the nervous influence

controlled by a glycogenic nerve center located in the medulla oblongata; therefore, the liver regulates the amount of sugar which should pass into the blood. The amount found in the blood at any one time varies normally from 0.05 to 0.17 per cent. An excess, should the liver fail to regulate the amount of sugar entering the blood, is eliminated by the kidneys and diabetes results. When the amount of sugar in the blood rises above 0.2 per cent. this condition always occurs.

The glycogen storing power of the liver is limited, and should there be an excessive amount this excess may be stored up in other organs.

Glycogen is found in large quantities in the musculature of the embryo, which points to the fact that it is used in making rapid growth and development.

Another function of this important gland is the *formation of urea*. In cell metabolism, in the disintegration of protein bodies, certain amino-acids, as tyrosin and leucin, are formed.

Metabolism consists of two processes—namely, *katabolism* or the tearing-down process and *anabolism* or the building-up process. It is in the katabolic end that these end-bodies are formed which, by undergoing oxidation in the liver, are converted into urea, which is carried by the blood from the liver to the kidneys, where it is eliminated.

A retention of urea in the body proves very poisonous and excessive quantities cause uremic poisoning, later uremic coma and death.

The liver also possesses the power of converting certain poisonous compounds into non-poisonous compounds by changing their chemical composition; therefore, one function of the liver is a neutralizer of poisons.

There are stellate cells in the liver known as the Kupfer cells, which have phagocytic properties—that is, the power to take up bacteria coming in the blood from the intestines and destroying them, thus protecting the body against bacterial invasion. The functions of the liver may be summarized as follows:

- (1) To store up the excessive glycogen.
- (2) To regulate the amount of sugar circulating in the blood.
- (3) To form bile.

- (4) To guard against the introduction of noxious gases and other poisons, as ammonia, and to transform them into urea.
- (5) To neutralize poisons.
- (6) To excrete cholesterolin.
- (7) To furnish alkali bases.
- (8) To facilitate absorption of digested fats.
- (9) To guard against infection from the intestines.

Intestinal Digestive Juices.—In addition to the pancreatic juice and bile, the food, when emptied from the gizzard into the intestines, meets a third fluid, the succus entericus, which fluid is secreted by glands located in the wall of the small intestines. This digestive fluid contains several ferments, as follows:

(1) Erepsin, acting upon protein, converting peptone and deutro-albumoses into hexone bases and amino-acids.

(2) Maltase, acting upon sugars, converting dextrin and maltose into dextrose.

(3) Lactase, acting on sugar, converting milk-sugar into dextrose and galactose.

(4) Invertase, acting on sugar, converting cane-sugar into dextrose and levulose.

(5) Enterokinase, which possesses the power of activating the trypsinogen of the pancreatic juice, converting it into trypsin.

(6) A substance called secretin, which is secreted and absorbed and causes a stimulation of the pancreatic secretion.

Absorption of Digested Nutrients.—The lymph system is the drainage or sewage system of the body.

Lymph is a liquid by which the tissues of the body are nourished and which collects the waste or effete material from the tissues and carries it to the blood, through which channels it is carried to the various excretory organs and eliminated from the body.

Lymph circulates in vessels called lymphatic vessels, and this vascular system is called the lymphatic system.

The tissues are bathed in lymph. Lymph-spaces exist between the lymph capillaries and capillary blood-vessels, and there is a constant passage of fluid laden with nutrients from the blood capillaries into these spaces from which the cells are bathed and nourished. The liquid in these spaces receives the

effete or waste products resulting from cell metabolism, which, in turn, is carried away by the lymph capillaries and vessels.

Lymph is a fluid, alkaline in reaction, with a specific gravity of 1012 to 1021, and is slightly yellowish in color.

In many respects lymph may be compared to blood without the red blood-cells. It is capable of coagulation much as blood, except that the clot is longer in forming and is not so firm in consistency. Like blood it contains serum albumin, fibrinogen, and paraglobulin, but in smaller amounts. It contains cells, called lymph-cells, which resemble certain white cells of the blood. It also contains gases, principally carbon dioxid, as well as salts and extractives.

The fluid containing these is called lymph-plasma. Lymph-plasma is then lymph minus the cellular elements, and blood plasma is blood minus its cellular elements.

A group of lymph vessels is found in the mesentery supporting the intestines. These lymph vessels originate by lymph radicles in villi or minute teat-like projections located on the mucous surface of the small intestine. This lymph radicle is called a lacteal, because it absorbs the milk-like substance from the intestines, which is the emulsified fat, and surrounds this lacteal. In the villus there is found a network of capillary blood-vessels. The villus is covered with a basement membrane which possesses a layer of columnar epithelial cells. These cells are in touch with adenoid cells located on the inner surface of the villus and surrounding the lacteal. These columnar cells contain nuclei near their bases. The villi are provided with parallel arranged muscular fibers, which, by contraction, aided by the peristaltic action of the intestine, alternately fill and empty the lacteal vessels. The chyle is passed through the columnar cells to the adenoid cells, then to the lacteals, thence to the lymph vessels at the base of the villus, from whence it is carried by larger lymph vessels, finally emptying into the venous blood before it reaches the heart.

The chyle obtained from the intestines is a turbid liquid possessing an alkaline reaction and a specific gravity of about 1010 to 1020.

Capillaries are capable of absorbing substances in solution

from various parts of the body; thus, liquids introduced into the trachea or windpipe, as pilocarpin or morphin, will be absorbed. Birds absorb solutions of strychnin very rapidly when introduced by aid of a hypodermic syringe, either into the muscular structures or into the abdominal cavity. The author has repeatedly produced strychnia-poisoning in sixty seconds by such injections.

One grain of strychnin, given in a solution in warm water on an empty crop, will produce its poisonous effect in a very few minutes, showing absorption from those mucous membranes is rather rapid.

Birds will absorb certain substances through the skin; thus, it came to the notice of the author that on several occasions birds which had been dusted with insect powder, containing tobacco dust and other ingredients in considerable amounts, became poisoned and some had died. The results of the poison was invariably an acute hepatitis or inflammation of the liver.

Absorption from the small intestines is from two sources—(1) through the villi into the lacteals, described above, and (2) through the venous capillaries or minute blood-vessels lining the mucous membrane.

Urinary Excretion.—The kidneys eliminate nitrogenous tissue waste, as well as certain salts and the excess water in the body.

The kidneys, two in number, are large in size and dark in color, irregular in shape, and lay in excavations in the lumbo-pelvic region. In the bird they are very large as compared to the size of the bird.

Urine is usually regarded as an excretion because it is of no further use to the body.

The waste material from the lymph-spaces throughout the body, being collected by capillaries and carried by the blood-vessels to the heart, is laden with nitrogenous tissue waste. From the heart the blood is pumped through the arterial system to all parts of the body. The arterial blood, constantly passing through the kidneys, carries a constant supply of the nitrogenous tissue waste from which urea is manufactured by the liver, and other salts are also removed and thus eliminated from the body.

CHAPTER XIII

NUTRITION

Tissue waste or wear and tear is constantly going on in the body of the fowl. As fast as destruction takes place repair must follow or death is the result.

The body of a mature fowl consists of 55.8 per cent. water, 3.8 per cent. ash, 21.6 per cent. protein, and 17 per cent. fat.

A larger portion of the body weight is always water. Salts are always the smallest amount. The amount of fat depends on the condition of the bird. In fat adult birds it may be three times the estimate above.

The bulk of the body is muscle, which holds half the water and half the protein found.

As shown before, the income of the body consists of four essential elements—namely, carbon, hydrogen, oxygen, and nitrogen, together with water, sulphur, phosphorus, and other salts. All of these elements, except a part of the oxygen, are taken in through the food. Much oxygen is taken in through the lungs in respiration.

The outgo or expenditures of the body consist of the same elements, and are eliminated from the body by way of the lungs, urine, and skin.

It is probable that *nitrogen is excreted* almost wholly through the kidneys by the urine. It is eliminated principally as uric acid. The hydrogen is eliminated from the body in form of water (H_2O). Water is given off by the urine and lungs.

Carbon is eliminated from the body principally as carbon dioxide (CO_2) by way of the lungs. Some is also gotten rid of through the kidneys. Salts (ash) are eliminated by the kidneys through the cells of the tubules. Sulphur is utilized and lost through the formation of epithelium, feathers and horn of the spurs, toes, and beak, as well as through the kidneys.

Since the feces or droppings consist of food nutrients which

have either escaped digestion or are undigestible, the intake of the body may be ascertained by subtracting the food nutrients consumed in twenty-four hours and the nutrients passing off in the same length of time undigested and unabsorbed.

When the intake of the body balances the outgo, the bird neither loses or gains in weight, and an equilibrium is established. If the intake exceeds the expenditures the bird gains weight; if the intake is less than the expenditures the bird loses weight.

Metabolism.—By metabolism we mean the changes taking place in the living tissue.

Every muscular contraction, the beating of the heart, the muscular movements of the bowels and oviduct, movements in respiration, all mean wear and tear or tissue waste and must be repaired as rapidly as the part is destroyed. The process of tearing down or destruction is called *katabolism*, and that of building up, *anabolism*.

It is quite apparent that metabolism is under the influence of the nervous system.

The elements required to make good this tissue waste must be contained in the food. These elements are in the form of water, ash, protein (nitrogen-containing nutrient), fats and oils (hydrocarbons), and starches and sugars (carbohydrates). Each of these groups of food nutrients must be in the proper proportion for the purpose for which the birds are being fed.

The nitrogenous nutrients digested, absorbed, and carried to the cells of the body, as told under the subject of digestion, is not stored up in the body, but immediately used. Voit contends that the digested protein after being absorbed is divided or split up in the tissues into two portions. One portion repairing the cells injured in wear and tear and the other circulating in the blood and lymph, bathing the cells, is destroyed in combustion in the production of heat and energy and the nitrogen end-products which are eliminated in the form of uric acid by the kidneys.

In the young and developing animal the protein is also used in nitrogenous tissue growth and expansion.

To summarize, we may say that the body, whether it be mature, growing, in egg production, or fattening, needs nitro-

gen. The body utilizes the small amount of nitrogen needed to replace wear and tear or nitrogenous tissue waste, growth, and egg production and excretes the remainder, principally in the form of uric acid, by the kidneys. Protein is not a source of muscular energy, but increased muscular effort must be met with an increased amount of protein in the feed to make good nitrogenous tissue waste. Heavy egg production and growth must be met with increased protein content of the food.

The non-nitrogenous food nutrients are *carbohydrates* and *hydrocarbons*. The nutrients constituting the carbohydrate group are starch, sugar, cellulose, and gum. As discussed under digestion, these must be digested—that is, rendered soluble, and in a form capable of being absorbed and assimilated. They are probably all converted into one form of sugar—namely, glucose, and as such are absorbed. Protein, in splitting up in the body in the process of cell metabolism, forms a nitrogenous and non-nitrogenous portion. The non-nitrogenous portion of the protein adds to the carbohydrate group in the body. It is capable of being transformed into glycogen.

In the body tissues the carbohydrates are readily oxidized. It will be seen that in dextrose, which has a chemical formula of $C_{12}H_{24}O_{12}$, that the molecule contains enough oxygen to oxidize the hydrogen after the disintegration of the carbohydrate molecule. It, therefore, need only draw from the tissues oxygen for the oxidation of the carbon. This is quite different from what we will see in the fats and oils or hydrocarbons, where the oxygen is far too small to oxidize all the hydrogen of the molecule. Therefore, the fats need to obtain oxygen from the tissues for the oxidation of all the carbon and a greater part of the hydrogen.

One gram of carbohydrate requires 50.8 cubic inches of oxygen, which produces 50.8 cubic inches carbon dioxide (CO_2), while 1 gram fat requires 17.6 cubic inches of oxygen, which produces 87.5 cubic inches carbon dioxide.

Carbohydrates are one source of muscular energy. Combustion takes place during muscular contraction. As a result of this oxidation, heat and energy are both produced. The

products of this combustion are water (H_2O) and carbon dioxide (CO_2). The disintegration of the carbohydrates in the muscles is brought about by aid of a ferment, so that the atoms of the molecule are separated, making reformation or combustion possible. One gram (15 grains) of sugar, when used in the body for the production of heat, will produce 4 calories (a calorie is a heat unit representing the amount of heat required to raise 2.2 pounds of water to $1.8^\circ F.$ or 1 kg. of water to $1^\circ C$).

The oxidation or combustive processes are constantly going on in the body of the bird. During rest the combustion is reduced to a minimum, and need only provide heat for the maintenance of the body temperature and for the living processes (the beating of the heart, respiration, and intestinal movement), and during activity for the extra exertion.

Carbohydrates are often spoken of as a protein saver, because 10 per cent. less protein is required where carbohydrates form part of the ration, therefore the ration must contain its proper amount of carbohydrates. A diet of carbohydrates without protein, however, means starvation. An excessive amount of carbohydrates is stored up in the body as fat.

The potential energy yielded by protein is equal to that of carbohydrates. In energy 1 gram is capable of producing 6.3 foot tons.

Fats and *oils* or hydrocarbons, like carbohydrates, are used for oxidation purposes in the body and the production of heat and energy. A surplus is stored up in the body as fat. For the production of heat fat is more valuable than starch or sugar. One gram (15.5 grains) of fat when oxidized produces 9.3 calories, or 14.2 foot tons. Therefore, in computing the nutritive ratio of a ration the hydrocarbons or fats and oils of the food are multiplied by 2.25, because 1 pound of fat will produce approximately as much heat when utilized in the body for that purpose as 2.25 pounds carbohydrates.

There are certain fat reservoirs or depots in the body of the bird. These are found beneath the peritoneum and in the mesentery. These depots are drawn upon in starvation or times when the income of the body is less than the outgo, or, in other words, when the demands of the body are greater than

the supply. The conditions ideal for laying on fat are found to be as in the case of finishing birds, where exercise is restricted and proper diet given.

Mineral Requirements of Fowls.—The mineral substances which enter into the composition of fowls constitute the ash. Certain minerals are required for secretion and function. The force feeding of fowls for growth into broilers, as well as in egg production as applied to mature hens, both call for a higher percentage of mineral nutrients in feed stuffs than was necessary under the old system of less intense production. Minerals are also required for growth and repair.

Use of Mineral in the Body.—The importance of mineral salts in the vital processes of the animal cell lies almost entirely in their physical or physico-chemical properties. The chemical reaction in the body which constitutes the physical basis of life takes place between substances in solution, and it is by means of the electrical charges carried by the particles in solution that reactions are brought about.

The mineral elements in the body are most of them strongly acid or basic, and their compounds have a tendency to become exceedingly active when in dilute solution; also the small size of the molecules of their simpler compounds allows them to pass freely through cell membranes that are impenetrable to many of the larger molecules of the complex compounds. The mineral substances of fowls' tissues exist not merely in solution but partly in firm combination with the organic constituents. These mineral substances render chemically active the large and inert organic complexes to which they are bound.

Kinds of Minerals.—The minerals of the body occur in the form of calcium oxide, inorganic phosphates, lecithins, phosphoproteins. In the inorganic phosphates phosphorus is present as salts of the mineral bases, calcium, magnesium, potassium, and iron. Sodium occurs principally as sodium chloride and to a less extent as sodium phosphate and sodium carbonate. Potassium is present mostly as salts of mineral acids. Magnesium usually combines with phosphate forming magnesium phosphate; sulphur in combination with proteid

bodies. Chlorine is in combination with sodium as sodium chloride. Iron is in combination with hemoglobin.

In the body the base forming elements are calcium, magnesium, sodium, and potassium. The acid-forming elements are phosphorus, chlorine, and sulphur.

Acid mineral elements enter the body in organic combination as follows: sulphur as a constituent of food protein including horn and feathers. If sulphur is oxidized it is burned into sulphuric acid and excreted in the urine as inorganic sulphates. Sulphates and phosphates result from proteid tissue waste and by oxidation of food protein in the body. These are eliminated from the body as such. Phosphorus enters the body as inorganic phosphates; as salts of various organic acids; as lecithins (compounds of fat), phosphoric acid, and in phosphoproteins and nucleoproteins. The eliminated phosphorus by way of the urine is in the form of di- and mono-hydrogen phosphates of sodium and potassium and less abundantly in the form of phosphates of calcium and magnesium. The phosphorus of the feces is largely in the form of phosphates. Chlorine enters the body as chlorides and is eliminated by the kidneys almost wholly as chlorides.

The organic acids of feed stuffs, such as citric, malic and tartaric acids of fruits, are mostly oxidized in the animal body to carbon dioxid and water, in which compounds they are excreted from the body. There are formed within the body, mineral acids which cannot be eliminated in this way. These acids must be neutralized in order to protect the animal from a disturbance of conditions essential to the continuance of vital reactions.

These acids are formed chiefly by the cleavage and oxidation of proteids, either of the body or of the feed, the sulphur and phosphorus contained therein, as constituent parts, being oxidized to the corresponding inorganic acids.

The practical bearing of the subject is on feeding of such animals as are largely reared on cereals, namely, poultry.

In this connection there is considered especially the acid mineral elements, sulphur, phosphorus, and chlorine, and the basic mineral elements, sodium, potassium, magnesium, and calcium.

The relative amount of mineral acids formed in the body may be greatly modified by a choice of feed stuffs. Alkaline ash is contained in fruits, vegetables, and milk, while acid ash is contained in meat scrap, or meat meal, eggs, cereals, and their by-products.

The bases are more deficient than the acids. The basic mineral elements in a ration must be in quantities corresponding to the protein, since the sulphur and phosphorus of the feed proteins constitute the principle sources of mineral acids in the body. The excess of mineral bases in the feed must be maintained at a high level. In practice animals do not experience injurious excesses of alkali as they do excess of acid. A needless amount of protein unnecessarily taxes the acid-neutralizing capacity of the animal and if carried to a sufficient extreme, results either in interference of the formation of bone or in malnutrition of the same. A high fat-content, or indigestible character of the fat of milk fed to individuals suffering from digestive disturbances, causes acid intoxication through withdrawal of alkalies by way of the feces.

Drought conditions or poverty of the soil in minerals may affect the ash content of the feeds. If the soil is poor in calcium and phosphorus the crop will be correspondingly poor. Such feeds will limit the growth and development of bone. If a sufficient amount of vegetables, fruits, and milk are given there is not likely to be an excess of mineral acids above the capacity of the body to neutralize. Clover and alfalfa are especially rich in calcium and hence are excellent, either as pasturage, cut green or ground and fed in the mash, to make good deficiencies in such grains as corn.

Aid to Construction of Tissues.—Bone contains calcium in the form of calcium phosphate, carbonate, and fluoride. It contains magnesium in the form of phosphate of magnesium. There is also present sodium chloride.

The fluids contain approximately 0.85 per cent. sodium chlorid.

Protein bodies, feathers, and horn contain sulphur.

The hemoglobin of the red blood corpuscle contains iron. The nucleus of cells as the white blood cell contains phosphorus,

as does also prothrombin. The blood also contains considerable amounts of potassium chloride and sodium carbonate. Next in abundance are phosphates of calcium, magnesium, and sodium, the chief inorganic constituents of the cells being potassium phosphate. In the plasma sodium chloride is the most abundant salt.

In the construction of the tissues of the growing chick, calcium, phosphorus, potassium, sodium, and chlorine play the most abundant part.

Aid to Function.—The presence of calcium salts is necessary for muscular contraction, and the control of both voluntary and involuntary muscles is accomplished through the proportion of calcium, magnesium, sodium, and potassium salts acting upon them. Sodium salts are essential to cardiac relaxation; in fact the heart cannot functionate without the presence of sodium and calcium salts. The blood cannot coagulate, when drawn, without the presence of calcium salts. The essential alkalinity of the blood is due to the phosphate and bicarbonate of sodium. Iron is essential in the red blood cells to give it its oxygen carrying power, 0.4 per cent. of the hemoglobin being iron. The nature of the inner stimulus of the heart is intimately connected with certain organic salts of sodium, calcium, and potassium. These are probably in the form of chlorides. It has been shown that calcium promotes contraction and that sodium and potassium bring about relaxation of the heart. The sodium carbonate of the blood probably assists in carrying the carbon dioxide to the eliminative organs, the lungs.

Free acid formation in the stomach of fowls is probably formed by selective powers possessed by the secretive cells by an interaction of sodium chloride and sodium di-hydrogen phosphate of the blood. The digestive fluid secreted by the glands of Lieberkühn is alkaline due to sodium carbonate. The pancreatic secretion contains much sodium, magnesium, potassium, and calcium in combination with chloride, carbonate, and phosphate. Bile contains sulphur, phosphate, and chloride of sodium, and salts of calcium, magnesium, iron, and potassium. The larger portion of salt is sodium. The salts of the body perform important functions in connection

with secretion and excretion. They direct metabolism of the body, though how is little understood. They regulate the fluid flow from blood to tissues and vice versa. Irritability of muscle and nerve is due to salts.

Young growing birds require more salts than adults. The activity of enzymes, whose function in building up and tearing down chemical compounds in the animal body requires certain degrees of acidity and alkalinity, which is maintained in proper degree through the presence of mineral salts. Animals can live but a short time on feeds free from mineral salts.

Salts assist in the formation of secretions, repair, and disintegration. The growth of solid tissue depends on the inorganic material supplied by the blood. One of the important functions of the salts in the blood is to maintain the vitality of the tissues. This is one of the principal functions of sodium chloride.

The excess of mineral bases in the food must be maintained at a high level.

Wheat and other seeds are deficient in calcium, sodium and chlorine.

Essential Food Nutrients.—The properly balanced feed mixture must have the proper kinds and quantities of **amino acids** in the protein, the proper kinds and quantities of mineral matter, and feed stuffs readily digestible and assimilable. There must also be the proper amount of fat soluble vitamine or food hormone.

A food **hormone** is an essential element or life-giving substance essential for maintenance of life and for proper growth of the bird. There are two kinds of hormones: first, a water soluble hormone found in abundance in all feed stuffs, and second, a fat soluble hormone found only in the fat of eggs, the fat of milk, certain parenchymatous glands as the liver and kidneys, and to a degree in the leaves of plants. It is not found in muscle structure. An animal will not grow on seeds alone. The fat soluble hormone is not found in the vegetable oils. Birds without the fat soluble vitamine will die in about two weeks. The symptoms are at first swelling of the eyes and eyelids, and the eye balls may burst. Feeding the bird egg yolk or butter-fat will relieve this condition. If the water

MINERAL CONTENT OF THE BODIES OF THE FOWLS^a
 [Results Expressed as Parts Per Hundred]

Age	Potassium	Sodium	Calcium	Magnesium	Sulphur	Chlorin	Phosphorus	Iron
Baby chick ^b	0.2922	0.2774	0.1978	0.0028	0.0107	0.1510	0.355	0.0054
½-pound broiler (Single-comb White Leghorn).....	0.2380	0.1580	1.0340	0.0440	0.3030	0.0790	1.288	0.0056
1-year-old hen (Columbian Wyandotte).....	0.2750	0.1640	1.2970	0.0510	0.3820	0.2080	1.510	0.0066

^a Chemical analyses in this work were made by Mr. Dan M. McCarty, Physiological Chemist, Animal Industry Division, North Carolina Experiment Station.

^b The baby chicks were taken from the incubator, killed with chloroform, and their abdominal yolk sacs removed.

soluble substance is left out of the feed of animals as laboratory rabbits or rats, no sore eyes will develop, but in a few weeks there will be paralysis of the hind legs followed by death. This is a condition called beri beri or polyneuritis. Nature stores up vitamine for the young bird, this vitamine being in the yolk of the egg.

MacCollom says that egg pound for pound is three times as valuable as beef, pork, or mutton, and six times as valuable as peas or beans.

It will require from 25 to 40 pounds of green leaves of vegetables to equal one pound of egg from a vitamine standpoint. Thick storage leaves do not contain as much vitamins as thin non-storage leaves.

Proteins are found in the living parts of the plant. They occur in a dissolved state in the circulating fluids and in the solutions of the cell vacuoles, that is, in the cell sap. They occur in a semi-dissolved state in the protoplasm, and in the undissolved state as reserve protein in the cells of seeds, tubers, and roots.

An analyses of these proteins show the following amino acids: Histidin, arginin, lysin, cystin, tryptophane, tyrosin, serin, glutaminic acid, aspartic acid, phenylalanine, proline, leucine, valine, alanine, and glyacoll. Certain of these amino acids are essential for maintenance, among these may be mentioned tryptophane and Histidin. Others are essential to growth of the bird. Among these may be mentioned lysin and cystin.

From this discussion it will be seen that the principal groups of food nutrients taken into consideration in the balancing of rations is the proper amounts of protein, hydrocarbons (fats and oils), and carbohydrates (starches and sugars), with a proper consideration of salts. This latter in the case of the young and rapidly growing chicks is very essential.

The *amount of water* in the body varies, but in general we may say that the amount will run from 55 to 75 per cent. of the body weight. In hot weather more water is lost from the body than in cool weather, and hence more is consumed. More is also consumed when the fowl is exercising than when quiet. Fowls consume large quantities of water. Water is

taken in through both feed and drink. Grain contains varying amounts of water, but usually from 10 to 15 per cent. of their weight is water.

When an excessive amount of water has been taken into the body the excessive amount is not stored, but escapes through the bowels or is eliminated by way of the kidneys. An animal will die when it has lost 10 per cent. of its body weight through thirst; it will not die from starvation till all the fat of its body has disappeared and 50 per cent. of its protein. From this it will be seen that the withholding of water or fluid is a more serious condition than the withholding of other foods. Egg production is retarded by lack of sufficient water.

Recent experiments have shown that a six-pound bird will consume on an average about five ounces of water in the warm summer days.

CHAPTER XIV

DIGESTIBILITY AND NUTRITIVE RATIO

THE leading quality of feedstuffs is digestibility. All nutrients taken into the body are not digested, nor is there a 100 per cent. of any nutrients digested.

The percentage feed nutrients capable of being digested and assimilated varies from 98 per cent. in the case of cows' milk and eggs to less than 50 per cent. in the case of wheat and oat straw.

Grains rank higher in digestibility than coarse roughage. Thus, 40 to 80 per cent. protein in coarse fodder may be capable of being digested, while only 30 to 68 per cent. of the crude fiber is available.

Digestibility of fats and oils vary greatly, ranging from 90 per cent. in some cereals to as low as 30 per cent. in some kinds of straw.

At times cut or ground alfalfa or clover is used in compounding the dry mashes for poultry. It has been determined that the degree of maturity affects the digestibility of plants. In one experiment conducted with cattle it was found that in clover cut while just coming in bloom 71 per cent. of the protein was digested. If cut and cured in full bloom but 65 per cent. was digested, and if cut toward the end of blooming only 59 per cent. could be digested.

Trials with animals have been conducted in feeding a *protein diet exclusively*. The results were an increased decomposition of the protein in the body as the quantity was increased and the excess does not go to form flesh. Protein consumption in the body is apparently, in part, dependent upon the condition of the animal's body as a result of previous feeding. Voit showed by experiments that fat when fed alone does not decrease protein consumption in the body. Carbohydrates, when fed alone, have the same effect as fat—that is,

it has no influence on protein consumption in the body. In animals fed on a mixed diet, containing carbohydrates, hydrocarbons, and protein, the protein consumption depends on the supply of the protein in the feed. The best results are obtained when the ration contains protein and carbohydrates and hydrocarbons, the two latter considerably in excess of the protein. Carbohydrates and hydrocarbons influence protein consumption by lessening the amount needed in the body. Carbohydrates and hydrocarbons are practically of equal value as a protein saver. The relative fuel value of these two groups of nutrients is not a measure of their comparative nutritive value.

Salt has a stimulating effect upon the appetite and makes the mash more palatable. It aids absorption of digested nutrients by facilitating the passage of digested albuminous nutrients from the digestive tract into the blood capillaries. It increases the vital processes. Experiments show that salt increases the excretion of urine.

Fat stored in the body originates from three sources—namely: (1) From decomposition of the protein; (2) from the carbohydrates, and (3) from the hydrocarbons.

All the manifestations of life, shown in a hundred ways by the bird, are in some manner derived from the food. It is the source of force, muscular energy, egg formation, growth, and development.

The domestic fowls are kept for ornamental purposes, for the production of eggs and meat, and therefore must be fed a proper ration for these various purposes.

The unit of measure of the ration is called, for convenience, the *nutritive ratio*.

The nutritive ratio of a ration is the amount of protein in proportion to the amount of carbohydrates or its equivalent in fat it contains.

The figure one (1) is always taken as the unit representing the protein. Thus, 1:10 would read one to ten, meaning that the ration contained 1 pound of protein to every 10 pounds of carbohydrates or its equivalent in fat. As stated before, fat gives off approximately 2.25 times as much heat when oxidized for that purpose as the same quantity of carbohydrates; hence,

in calculating the nutritive ratio of a ration, the quantity of fat it contains is multiplied by 2.25, and the result is added to the carbohydrates, which result is divided by the protein and this gives the nutritive ratio.

Thus, for example, if we prepare a morning scratch feed for a flock of laying hens, which feed consisted of equal parts of oats and wheat, its nutritive ratio would be computed as follows:

By referring to the table of digestibility, it is found that there is contained in every 100 pounds wheat 10.2 pounds protein, 69.2 pounds carbohydrates, and 1.7 pounds hydrocarbons or ether extract. Oats contain 9.2 pounds protein, 47.3 pounds carbohydrates, and 4.2 pounds hydrocarbons or fats. Thus we have:

	Protein.	Carbohydrates.	Hydrocarbons.
Wheat.....	10.2	69.2	1.7
Oats.....	9.2	47.3	4.2
Total..	19.4	116.5	5.9

Since 1 pound of fat is equivalent to 2.25 pounds of carbohydrates in the body the fat is reduced to carbohydrates, which gives us the following:

$5.9 \times 2.25 = 13.27$, that is, the 5.9 pounds of fat the ration contains is equivalent to 13.27 pounds carbohydrates, which gives us the following:

$116.5 + 13.27 = 129.77$ pounds carbohydrate equivalent.

The proportionate amount of protein to carbohydrates and carbohydrate equivalent is as follows:

$129.77 \div 19.40 = 6.6$, that is, the nutritive ratio is 1:6.6, and is read one to six and six-tenths, or the feed contains one pound protein to six and six-tenths pounds carbohydrate equivalent.

Birds need animal protein, which may be supplied by fish-scrap, meat-meal, bone-meal, and milk. Fish-scrap can be purchased from certain firms along the coast, while from the small abattoirs rapidly going up at the smaller towns over the country there can be purchased pure dried blood and tankage. At many of these places the blood is saved, and the clotted blood without cooking is placed in the dryer and dessicated and sold as such (dried blood). The viscera of the cattle and sheep, as well as hogs (bowels and stomachs), are ripped open

and thoroughly washed and placed in a closed tank and cooked, after which the grease is run off and the residue is drained of its water and placed in a dryer and dessicated. It is then ground into meal, and sold either as stock-food or as fertilizer. At these places the meat-meal or tankage can be purchased very reasonable. On every farm there is buttermilk, skim milk, clabber, or cottage cheese.

In the summer time, by foraging, the birds pick up much animal food, as insects and worms, besides from many tables the birds receive much such food.

If fish-scrap be used it must be remembered that very large quantities will cause the products (flesh and eggs) to have taken on an objectionable odor or fishy taste.

CHAPTER XV

FEEDSTUFFS

Corn.—There are two races of corn—namely, flint and dent, and a third may be considered—namely, sweet corn. Corn is high in starch content. In the flint corn most of the starch is hard and corneous in character, which is easily demonstrated by cutting a grain crosswise and examining it. In dent corn the starch is floury in nature, except a small portion near the exterior, which is hard and corneous. The corneous and floury parts are chemically the same.

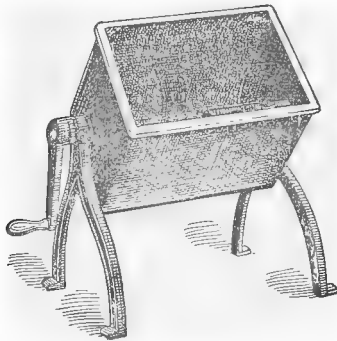

FIG. 99.—A convenient commercial feed mixer.

Corn may be of different colors, as white, yellow, red, and blue striped.

Yellow corn is objected to by some breeders of white plumage birds, believing that it causes the brassy luster on the coat, which shows most on the wing-bows and back.

The grain of sweet corn is hard and wrinkly. The hard, corneous character is due to shrinkage during the process of maturing. Sweet corn contains more protein and fat than flint or dent, but on the other hand it contains less digestible carbohydrates.

From the fact that corn is rather low in protein and high in carbohydrates it is spoken of as a carbonaceous food. Corn contains more oil than wheat, but less protein and carbohydrates.

Corn being rich in starch and oil, its chief function in the body should be that of production of heat and fat. Corn being low in ash and proper amino acid content is not adapted as a single feed in young and growing birds.

Corn may be fed to poultry whole, cracked, or ground.

The laws of the United States recognize 56 pounds of shelled corn as 1 bushel, and corn in the ear as 70 pounds.

In growth the corn grains develop on a central core or support called a cob (corn-cob). This cob consists chiefly of crude fiber or cellulose. It is low in digestible nutrients, and it is doubtful if poultry can utilize it with profit if it were finely ground and incorporated in the mash.

Corn and Cob Meal.—The entire ear—that is, corn and cob—is sometimes ground together, when it is sold as corn and cob meal. It is rather difficult to reduce the cob to fineness, so that such meal usually contains more or less larger pieces of cob.

The water in an ear of corn will vary from 10 to 20 per cent. After maturing it undergoes a shrinkage. This shrinkage in weight will amount to 6 to 10 per cent. of its total weight.

There are several by-products of corn that are of interest in poultry feeding. Some of these are as follows:

Corn bran, which consists of the outer two coats or covering of the grain. After the skin or outer layers are removed there is found a layer rich in protein. The germ is near the attached portion of the grain. The germ contains oil, ash, and protein. The body of the grain consists entirely of starch.

Gluten feed constitutes the by-products of the corn grain in the manufacture of starch. Gluten feed is rich in fats or oils and protein and can well form one of the ingredients of the dry mash. Gluten meal does not contain the germ or the hulls.

Cracked corn consists of the broken-up grains in more or less coarse particles. It is usual to sift such cracked corn and use the fine particles for the mash, and the coarser part, practically free from flour, for the scratch feed, thus not placing the finer particles in the scratch feed to be wasted.

Cornmeal consists of the finely ground whole grain.

Wheat constitutes one of the very best poultry feeds. Wheat carries less fat or oil but more starch and protein than corn. It is, therefore, a more nearly balanced ration fed alone than corn, better meeting the needs of the young and developing chick. Wheat may satisfactorily form a part of the rations for most all purposes in poultry feeding, as for egg production, growth, and development, and for finishing work. There are many varieties of wheat. Wheat may be fed whole, as in scratch feed, cracked, as in chick-feeding, or ground, forming part of the mash.

Sixty pounds of wheat constitute a bushel.

In buying any kind of feed for poultry one should avoid spoiled, moldy, or rotten feeds. Shrunken wheat is often sold as "chick wheat," but it must be remembered in buying this grade of wheat that the grains are lower in digestible food nutrients than the plump, fully developed grains of wheat usually sold as seed wheat.

In studying the structure of a wheat grain, we find that it is surrounded with three outer coats which show about the same composition with corresponding feeding value as the straw. Beneath these three coats we find the fourth or aleurone layer. This layer during the process of milling goes with the outer three coats to form bran and middlings. It is rich in protein.

The germ or embryo of the wheat grain is rich in mineral matter (ash), protein, and oil. Thin-walled starch cells make up the balance of the grain. Protein matter or gluten is found associated with these starch cells. It is the gluten of the flour that causes the dough to be sticky. This tenacity enables it to retain the gas-bubbles which form in the process of yeast fermentation preparatory to baking. This causes the porous or so-called light bread.

In the manufacture of flour from 25 to 35 per cent. of the weight of the wheat grains goes to form by-products, as shorts, middlings, and bran. *Shorts* sometimes consist of ground-over bran. *Shorts* are supposed to contain more of the finer particles of the by-product, excluding much of the coarser outer hull layers. *Middlings* contain more of the finer particles than bran.

Bran is made up almost wholly of the three outer layers, with some of the aleurone and finer particles of flour which has escaped into the by-products in its manufacture.

In some cities, like New York, the quantity of stale bread is enormous. Some of this is dried and ground and sold on the market for baby-chick feeding under the name of bread crumbs or dried ground bread. Cracker crumbs from cracker factories are also sometimes used for baby-chick feeding.

There is manufactured a low-grade flour known as "red dog;" it usually contains the germs of the wheat grains, which makes it rich in protein and fat. This may well form a part of the mash for young chicks, egg-producers, or, combined with corn-meal and milk, as a finishing ration.

Shorts, middlings, and bran form a prominent part in poultry feeding, being incorporated in most mashes.

Rye is another grain not used to as great extent as corn and wheat.

Rye may be attacked by a fungus, the *Claviceps purpurea*, causing the so-called ergotized grain. Ergot is the product of a fungus disease.

Ergot exerts its effect upon the vascular system, especially the blood-vessels, causing a contraction of the vessel walls. When birds consume considerable amounts there is noted a dry gangrene of the comb and wattles.

Rye carries 9.9 per cent. protein, 68.7 per cent. carbohydrates, and 1.1 per cent. fat. This should form a good poultry feed.

Barley and its products are not used generally throughout the United States.

Barley is used to a great extent in brewing, and is grown quite extensively in some of the Western States.

In the process of brewing the grain undergoes a process known as malting. In this process the barley is soaked in large vats made of cement or wood. As soon as it has become soft, so that the grains can readily be crushed between the thumb and finger without yielding a milky juice, it is taken out of the vat and spread in layers, about 18 to 20 inches deep, on racks or frames. The temperature in this room is maintained at about 150° F. and the grain left till it begins to sprout.

From these frames the sprouting barley is placed on the floor, where the process of germination can be controlled.

In the barley grain there is a considerable quantity of starch, and with the proper temperature, which is furnished in the process of malting, the diastase converts the starch into sugar and soluble dextrin. The malster looses all the barley grain which goes into the sprout, but this he cannot help, and so to make up for the loss the sprouts are sold as a by-product for feeding purposes. Malt cannot be produced except by this sprouting process. In the malting close watch is kept and the growth suddenly checked when the proper point has been reached. The juice from this malted barley grain is called wort, which, by further fermentation, is converted into beer. The dried malted grain is called dried brewers' grain, and the same product in the wet state, as it comes from the brewery, is called wet brewers' grain. In the vicinities of breweries the wet brewers' grain is hauled away by the wagonload for dairy feeding. The dried germs are called malt sprouts.

There is no reason why dried brewers' grain or malt sprouts should not form a part of the dry mash for poultry feeding.

Barley contains 8.7 per cent. protein, ranking with corn, while malt sprouts contain 18.6 per cent. and dried brewers' grain 15.7 per cent. In fat, barley contains 1.6 per cent., malt sprouts 1.7 per cent., and dried brewers' grain 5.1 per cent. Barley carries 65.6 per cent. carbohydrates, while the malt sprouts carry 37.1 per cent. and the dried brewers' grain 36.3 per cent.

Forty-seven pounds barley constitute one bushel.

Oats, like corn and wheat, form one of the principal feeds for poultry. The oat crop ranks third of the cereals in this country. Oats vary greatly in weight. The standard weight in most states is fixed at 32 pounds to the bushel, a bushel measure in some cases weighing as low as 20 pounds, and in others as high as 50 pounds. This difference is apparently due to various reasons, such as seasons, soils, and kind of oats sown. A very important factor in the weight of oats as compared to volume appears to be the proportion of husk and its looseness to the kernel. The hulls of oats constitute from 24 to 45 per cent. of the weight of the grain.

Oats apparently possess a stimulating substance. Johnston, believing that he had separated this active principle in 1885, called it avenine. This principle, according to Sanson, is contained in the hulls. While it exerts its effect upon horses, causing them to show metal, yet close observation has apparently not been made to determine if any stimulating effect comes from feeding oats to poultry.

The by-products in the manufacture of oatmeal is oat hulls, which are of low feeding value and can hardly be recommended in poultry feeding.

From these mills there may be obtained oat dust, which ranks close to the grain in composition and could be used in dry mash. Oat shorts, another good constituent for mash, is higher in nutrients, containing 12.5 per cent. protein, 46.9 per cent. carbohydrates, and 2.8 per cent. fat.

The form in which oats is most often fed is as follows—whole oats, either clipped or unclipped, constitute a part of the morning and evening scratch feed; rolled oats and pin-head oats for baby chicks; hulled oats for broiler-size chicks; sprouted oats for succulent feed.

Rice has not come into general use as a poultry feed. It is low in protein and fat, as can be seen by referring to the table of digestibility of food nutrients, but on the other hand it is rather high in carbohydrates, of which nutrient there is 72.2 per cent. digestible.

There are some by-products of rice of which rice hulls is one. This by-product consists of cellulose, which is very hard, woody, and cannot be recommended for poultry feeding. Rice bran consists of the outer portion of the rice grain with some of the germ. It contains 5.3 per cent. protein, .3 per cent. fat, and 45.1 per cent. carbohydrates.

Another by-product is rice polish, which is a dust-like powder rich in nutrients. It could well form a part of the dry mash in localities where it can be purchased at a reasonable price. It contains 9.0 per cent. protein, 6.5 per cent. fat, and 56.4 per cent. digestible carbohydrates.

Buckwheat is extensively grown in some localities and, where it can be purchased at a reasonable price, may prove profitable in the ration.

It will be noted that buckwheat is lower in digestible nutrients than corn, wheat, or oats; hence, to be profitable as a feed, must be purchased at a much lower figure.

There are several by-products in the manufacture of buckwheat flour.

The hulls are black and woody and cannot be recommended for poultry feeding.

Buckwheat middlings is a by-product in the manufacture of flour, and contains much of the material of the grain just inside the hull. It may well form a part of the dry mash, since it contains 22.0 per cent. digestible protein, 5.4 per cent. fat, and 33.4 per cent. carbohydrates.

Usually the hulls and middlings constitute buckwheat bran; its hull content makes this feed undesirable for poultry rations.

Buckwheat shorts contain 21.1 per cent. protein, 5.5 per cent. fat, and 33.5 per cent. carbohydrates.

Fifty-two pounds of buckwheat constitute a bushel.

Sorghum seed is fed to some extent to poultry. It is of slightly lower feeding value than corn, as can be seen from the table of digestible nutrients.

Broom-corn seed ranks a trifle under sorghum seed in value.

Kaffir corn is a close second to sorghum, carrying a trifle more protein and carbohydrates, but less fat.

Millet ranks with corn in protein, but is low in carbohydrates and fat.

Cotton-seed by-products are of questionable value in poultry feeding.

Cotton-seed hulls cannot be used.

Investigations by the author in the feeding of cotton-seed meal has shown good results in dry mash, where the cotton-seed-meal content did not exceed 10 per cent. of the mash. This test was carried on in 19 flocks of egg-producers for a period of six months.

Cotton-seed meal as a mash constituent in trough feeding or fattening of fowls proved that the meal, constituting 20 per cent. of the ration, was unpalatable in this quantity, and that the birds readily became sick of it and would not eat mash containing it, and a loss in weight resulted in some cases, and in others they would actually starve themselves, while

those of stronger constitution made some gains. The trial was carried on in seven lots of mature hens. Cram feeding was also tried with this same ration with one lot of 12 birds, which resulted in throwing 4 "off digestion," finally killing 3. The birds with stronger constitution made in some cases good gains. The ration consisted of ground oats, 2 parts; ground wheat, 2 parts; and cotton-seed meal, 1 part. In two lots the liquid used in mixing the mash was buttermilk, in two lots sweet milk, and in the other three water.

From this it will be seen that 20 per cent. cotton-seed meal in the entire ration for trough fattening of birds is unprofitable, and that in force feeding, as with the cramming machine, the birds of weaker constitution are thrown "off digestion" and may die. In several tests in finishing work with broilers mash containing 5 per cent. proved profitable. The length of feeding period was fourteen to sixteen days.

Three single comb White Leghorn cockerels were used in palatability tests. The feed consisted of wet mash, consisting of equal parts cornmeal, wheat bran, and cotton-seed meal. The birds went off feed on the fifth day, and while they ate other feeds readily they refused any feed containing the cotton-seed meal. It was not until the lapse of three weeks that they could be induced to eat a ration containing cotton-seed meal, and after again partaking of the mash went off feed in three days.

There is a possibility that birds will eat a larger quantity of cotton-seed meal where it is given in dry mash with morning and evening scratch feeds, but the poisonous properties of cotton-seed meal exerts a damaging effect upon the normal physiologic functions of delicate eaters and birds of rather weak constitution.

Many birds go off feed when the daily consumption of cotton-seed meal reaches about one ounce a day.

Cotton-seed meal ranks high in protein, containing 37.2 per cent. It contains 12.2 per cent. fat and only 16.9 per cent. carbohydrates.

Cotton-seed contains a substance which is poisonous to animals consuming large quantities of it. This is probably contained in gossypol, which is the coloring matter of the seed and

constitutes in the crude state about 2 per cent. of the seed. It affects the nervous system as well as the circulatory system. In extensive experiments carried on at the North Carolina Experiment Station it has been noted that its irritating effect is quite general in the animal body, injuring the capillary blood-vessels so that, at times, small hemorrhages are noted. Edema of the lungs has been noted by the author in both guinea-pigs and shoats dying of cotton-seed-meal poisoning.

Irritation and inflammation with hemorrhage into the bowel is common. Birds eating excessive amounts of cotton-seed meal and dying from its effects are apparently due to starvation. The lesions observed in hogs dying of cotton-seed-meal poisoning have not been observed in fowls.

Flaxseed and its products are rather expensive for poultry feeding. The seeds are high in protein and fat, containing 20.6 per cent. of the former and 2.9 per cent. of the latter. It is low in carbohydrates, containing only 17.1 per cent. The linseed meal (old process) contains 29.3 per cent. protein, 7.0 per cent. fat, and 32.7 per cent. carbohydrates. The new process meal contains but 28.2 per cent. protein, 2.8 per cent. fat, and 40.1 per cent. carbohydrates.

At the oil mills the flaxseed is crushed and the oil may be removed by either of two processes. In the old process the crushed seeds are heated and placed in sacks or between cloths, and these subjected to hydraulic pressure, which extracts the oil. After the extraction of the oil the residue appears as hard cakes, about 2 feet long, 1 foot wide, and 1 inch thick. These are the linseed cakes of commerce. When these cakes are broken up into pieces, varying in size from peas to English walnuts, the product is known as nut-cake. When the cakes are ground it constitutes the commercial old-process oil meal.

In the manufacture of new-process oil meal the seeds are crushed and heated to a temperature of 165° F. This heated mass is placed in a percolating cylinder and naphtha; a volatile petroleum compound is poured over it. This percolates through the mass and dissolves out the fat or oil.

After percolation is completed the mass is subjected to steam, which drives off the naphtha. The meal is now trans-

ferred to dryers, from which, after drying, it is sacked and sold as linseed meal or oil meal (new process).

Oil meal may be adulterated by mixing foreign matter to it or by the flaxseed having mixed with it weed-seed or immature flaxseed.

Fifty-six pounds of flaxseed constitute a bushel.

Velvet-bean Meal.—The tropical velvet bean flourishes in all the southern states. The vine grows from 15 to 75 feet in length and covers a large area as a dense mat. Velvet bean makes a good yield reaching 1800 pounds, or 30 bushels of 60 pounds each per acre.

Velvet-bean meal feeding work was conducted at the N. C. Experiment Station. It was found in 8 lots of broilers that 30 per cent. velvet-bean meal gave unfavorable results, 4 per cent. dying and the total losing 13 per cent. in weight. In 11 flocks of chicks reared up to eight weeks of age velvet-bean meal milk lots showed a mortality of 41 per cent. and the velvet-bean meal water lots a mortality of 48 per cent. The amount of velvet-bean meal used was 28 per cent. of the feed mixture. Control lots using middlings in the place of velvet-bean meal lots showed 30 per cent. mortality when given with water and 20 per cent. mortality when fed with milk.

From these tests velvet-bean meal, consisting of ground pods and beans, cannot be highly recommended as a poultry feed.

Fat extracted soybean meal contains 38.1 per cent. protein, 33.9 per cent. carbohydrates, and 5.0 per cent. fat.

Soybean Meal.—Soybean meal is left over after the extraction of the oil. This meal has given excellent results in fattening, egg production, as well as in chick rearing work.

Soybean produces a very large yield and is grown both for forage and for the beans. When grown for seed a yield of from 12 to 40 bushels per acre is obtained. Soybean is grown largely in the southern states. It is an excellent poultry feed.

Peanut Meal.—Peanut meal is a by-product in the manufacture of peanut oil. Like soybean meal it has given excellent results when forming part of the feed mixture for broiler production, egg production, and fattening. Cracked peanuts are also used in pigeon feeding.

Peanuts are grown largely in the southern states.

Fat extracted peanut meal contains 42.8 per cent. protein, 20.4 per cent. carbohydrates, and 7.2 per cent. fat.

Cow-peas are very rich in protein, containing 18.3 per cent., but low in fat, containing only 1.1 per cent. It contains 54.2 per cent. carbohydrates.

Ground cow-pea could be fed with profit as a constituent of the mash.

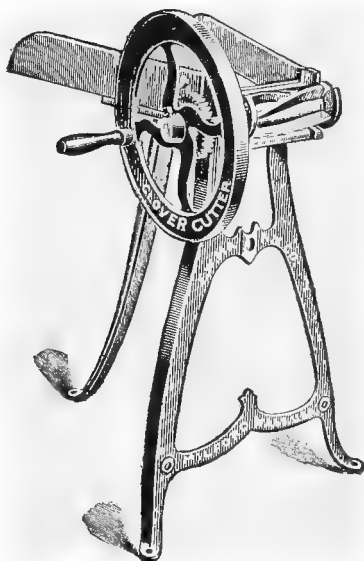

FIG. 100.—A green feed cutter sold on the market.

Animal protein is apparently essential in egg production and best results of growth and development. It may be given in the form of buttermilk, sweet milk, clabber milk, or cottage cheese. Dried animal tissue may be used as a constituent of the mash.

Condensed buttermilk is put on the market by some of the larger creameries. This product is in semisolid form and is condensed. On account of its lactic acid content, the finished product is self-preserving. It contains all the con-

stituents of normal buttermilk. **Dried buttermilk** is also prepared.

Milk Albumin.—In the process of the manufacture of milk sugar there is left over a by-product which is desiccated and sold as milk albumin. One pound of this dried material is added to 5 or 6 quarts of water and is used in mixing feed for the baby chicks and also as a drink for young and old stock. It is in fact the skimmed milk less the milk sugar.

In a study of the table of digestible nutrient it is found that dried blood contains 52.3 per cent. digestible protein and 2.5

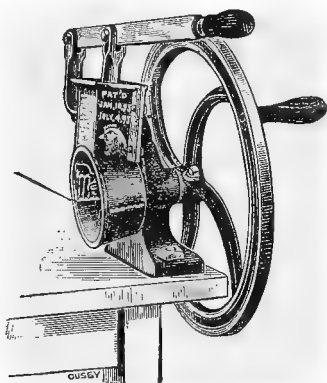

FIG. 101.—A green bone cutter sold on the market.

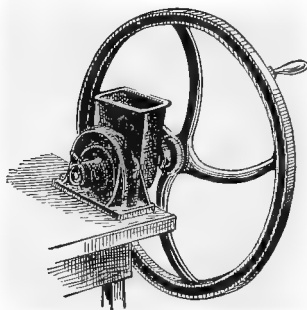

FIG. 102.—A dry bone grinder sold on the market.

per cent. digestible fat. Meat scrap varies; thus, there is on the market what is termed a high-grade protein meat meal which contains 55 per cent. protein, and another as pure ground meat scrap or low-grade protein meat meal containing only 45 per cent. In addition to this, meat meal contains about 0.3 per cent. carbohydrate and 13.7 per cent. fat.

There are many small slaughter-houses throughout the country where meat scrap can be purchased very reasonable. Some of these save the blood and dry it without cooking; it can be secured in a dried state and makes an excellent and cheap animal protein constituent in the mash.

At these abattoirs the trimmings and stomachs and intes-

tines, after being opened and thoroughly washed, are placed in a closed tank and cooked. After the fat is run off the residue is drained of its water and the solid placed in a dryer and, by the application of heat furnished by steam-pipes and agitation, is dried, after which it is ground. This makes a low-grade meat meal, which is usually sold as tankage and carries a digestibility of from 40 to 60 per cent.

Ground dry bone and cut green bone make excellent animal protein, furnishing at the same time much needed mineral matter, the mineral matter is principally calcium. The young and developing chick rapidly undergoes bone expansion and development requiring much calcium.

Dried fish scrap is obtainable along the coasts, and usually contains about 44.1 per cent. protein and 10.3 per cent. fat. Fish scrap, fed in large quantities, may impart an objectionable flavor to the flesh and eggs.

Jull reports that 10 per cent. fish scrap in the dry mash did not cause the eggs or meat of the fowl to be flavored of fish.

Beet pulp, while constituting a valuable feed for cattle for both fattening and milk production and for finishing sheep, could not be strongly recommended for poultry feeding. It is rather woody, hard to digest, and contains but 0.6 per cent. protein, 7.3 per cent. carbohydrates, and no fat. When beet pulp is fed it should first be soaked in water for twelve hours.

Hot mash given in the evening on cold days has a stimulating effect upon egg production. It is made by taking a quantity of bran shorts or middlings and scalding with boiling water. Sometimes mashed cooked vegetables, as potatoes, turnips, or rutabagas, are added.

Ensilage is also fed in some localities in the midwinter season.

Ensilage fed uncooked may cause sour crop which may be followed by diarrhea. If silage be fed it should be cooked.

Succulent feed is essential to breeding stock as well as to egg production. Succulent feed may be furnished in the form of cabbage, mangel, rutabaga, turnip, sprouted oats, or pasture of rape, clover, oats, or rye. The pasture should be used when it is from 1 to 2 inches high.

Sprouting Oats.—Fig. 103 illustrates a sprouting rack, as used at the North Carolina Experiment Station. It is 7 feet high and 2 feet square. The trays have a 4-inch marginal



FIG. 103.—An oat sprouting rack. A basement or cellar where there is some light and temperature above 60° F. is a good place in which to sprout the oats. The trays are removable.

board and a metal bottom, which is perforated so as to allow the excess of water to run out. The trays should not be too close together or the back parts will be shaded. They should be at least 12 inches apart.

To sprout oats the rack must be kept where the temperature is above 60° F. The incubator or other cellar will do, provided there is enough light.

Use only the best seed oats, as a poor grade of feeding oats that has a poor percentage of grains that will sprout will be very dear in the long run. The author has seen oats used in which no more than half the seeds would sprout, in which case the cost of production of the succulent feed, so far as the oat grains were concerned, was just double that paid for the oats.

These trays will hold about 6 quarts of oats. Place that quantity in a metal bucket and cover with warm water. The water should be close to 100° F. Allow the oats to soak in a warm room for twenty-four hours and then place in a layer in the rack. Wet the oats thoroughly once every twelve hours.

The sprouted oats should be fed when they are from 4 to 6 inches high. If the temperature is proper it will require about ten days for the oats to reach the proper size. Do not allow them to get old enough to turn yellow or woody. Likewise, do not allow the roots to turn yellow and spoil. They should be fed while the roots are white and in good condition. There is much succulence in the roots, and that part is just as essential as any other part of the young plant.

About 370 pounds of succulent feed can be produced from 100 pounds of oats.

Give one ounce of sprouted oats to each ten hens per day.

Grazing Crops for Poultry.—Grazing crops can be provided most of the year for poultry. From November to March, it is necessary to either sprout oats or provide mangles or turnips. For best results in egg production, birds must be provided with succulent feed.

The following tabulation will be found useful information for the beginner:

Oats may be used for either summer or winter grazing. Rape may be raised spring, summer, and fall if there is sufficient rainfall. Soybeans and cowpeas can be raised spring, summer, and fall as a yard rotation crop if there is sufficient rainfall. Turnips and mangles make the best root crops for winter feeding. Collards and cabbage, as well as lettuce raised in cold frames, also make excellent succulent feed. In

Crop	When sown	Amount of seed per acre	Grazing stage	Period duration
Peas and oats	Apr. 15	1 bu. peas, 2 bu. oats	May 20	Until full grown
Rape	May 10	3 pounds	8 to 10 inches high	Until consumed
Red clover	Aug. 20	12 pounds	May 15	Until fed down
Turnips	Aug. 20	3 pounds	Sept. 20	Until snow falls
Buckwheat	May 10	1 bushel	In six weeks	Until mature
Soybean	May 10	1 bushel	12 inches high	Until mature
Rye and crimson clover	Sept. 1	1 bu. rye, 15 lb. clover	Graze early winter and spring	
Oats	Sept. 1	1 bushel	Graze early winter and spring	
Sweet clover	Aug. 15	25 pounds	6 to 10 inches high	Until fed down
Mammoth prize long red mangles, orange globe mangles	May 1	8 pounds	For winter use	

raising mangles it is best to plough the ground deeply in the fall. The freezing will pulverize the ground and tend to make it in better condition for the crop. Good black loam soil is the best. The ground should be manured. If manure is not available, fertilize by distributing 400 to 500 pounds fertilizer to the acre. Plant the mangle seed in rows $2\frac{1}{2}$ to 3 feet apart, sow thick, later thin out, leaving one strong beet stock to each 10 inches. The rows should be ridged, the top of ridge being about 2 inches above the surface of the ground. The seed should be planted about 1 inch deep. Gather the root crops as late in the fall as possible. Bury in the ground until ready to use them. To do this, place about 6 inches of straw on the ground, then pile or make windrow; cover mangles, or turnips, with about 6 inches of straw or hay and cover with dirt. In securing the dirt take that close around the piles of roots so that there will be drainage away from the pile and thus keep dry. The roots thus prepared should keep till January and February, when they are most needed. During the fall and early winter grazing crops may be used.

MINERAL CONTENT OF POULTRY FEEDS

[Results expressed as parts per hundred]

Feed	Num-ber of analyses	Potas-sium	Sodium	Calcium	Mag-nesium	Sulphur	Chlorin	Phos-phorus	Iron
Cornmeal, bolted.....	4	0.349	0.072	0.0092	0.1336	0.160	0.0244	0.341	0.004
Pinhead oats.....	7	0.441	0.109	0.0126	0.0704	0.236	0.0900	0.499	0.0019
Rolled oats.....	2	0.370	0.136	0.0430	0.1560	0.256	0.0238	0.473	0.0062
Whole wheat.....	13	0.435	0.039	0.0271	0.1127	0.183	0.0630	0.436	0.007
Whole corn.....	13	0.332	0.041	0.0127	0.1051	0.148	0.0521	0.293	0.0044
Wheat middlings.....	6	0.949	1.219	0.0980	0.3628	0.232	0.0603	0.783	0.0052
Bone meal ^a	3	0.229	0.735	21.1770	0.5800	0.170	0.0900	10.349	0.018
Hulled oats.....	6	0.387	0.053	0.0915	0.1465	0.204	0.0870	0.454	0.0109
Meat and bone meal ^a	4	0.185	0.745	12.806	0.460	0.359	0.850	6.560	0.0580
Velvet-bean meal.....	1	1.186	0.141	0.360	0.208	0.151	0.222	0.704	0.0126
Soy bean meal (fat extract).....	1	1.189	0.415	0.238	0.298	0.438	0.032	0.664	0.0300
Peanut meal (fat extract).....	1	1.177	0.326	0.138	0.326	0.323	0.043	0.735	0.0300
Skim milk.....	2	0.151	0.144	0.153	0.0018	0.0424	0.065	0.136	0.0036
Egg, including shell.....	3	0.0103	0.200	0.608	0.0985	0.3950	0.150	0.302	0.0103
Rape, green.....	3	0.2510	0.008	0.0084	0.0206	0.0354	0.093	0.1026	0.00000076
Limestone grit.....	2	0.0000	0.000	30.9700	6.6700	0.000	0.000	0.000	3.330000
Oyster shell.....	2	0.0000	0.000	37.951	0.4200	0.147	0.090	0.000	0.375000

^a It is probable that in both bone meal and in meat and bone meal considerable tricalcium phosphate [Ca₃(PO₄)₂] is lost in burning.

AVERAGE DIGESTIBLE NUTRIENTS IN POULTRY FEEDS

The data of this table for the digestible nutrients are derived mainly from Bulletin 22, Office of Experiment Stations, U. S. Department of Agriculture, Washington; Handbook for Farmers and Dairymen, Woll; Farm Foods, Wolff (English edition, Cousins), and Zusammensetzung der Futtermittel, Dietrich and König.

Name of feed	Digestible nutrients in 100 pounds		
	Protein, pounds	Carbohy- drates, pounds	Ether extract, pounds
CONCENTRATES			
Corn, all analyses.....	7.9	66.7	4.3
Dent corn.....	7.8	66.7	4.3
Flint corn.....	8.0	66.2	4.3
Sweet corn.....	8.8	63.7	7.0
Corn-cob.....	0.4	52.5	0.3
Corn and cob meal.....	4.4	60.0	2.9
Corn bran.....	7.4	59.8	4.6
Gluten meal.....	25.8	43.3	11.0
Germ meal.....	9.0	61.2	6.2
Starch refuse.....	11.4	58.4	6.5
Grano-gluten.....	26.7	38.8	12.4
Hominy chops.....	7.5	55.2	6.8
Glucose meal.....	30.3	35.3	14.5
Sugar meal.....	18.7	51.7	8.7
Starch feed, wet.....	5.5	21.7	2.3
Hemp-seed.....	10.0	30.4	20.5
Wheat.....	10.2	69.2	1.7
High-grade flour.....	8.9	62.4	0.9
Low-grade flour.....	8.2	62.7	0.9
Dark feeding flour.....	13.5	61.3	2.0
Wheat bran.....	12.2	39.2	2.7
Wheat bran, spring wheat.....	12.9	40.1	3.4
Wheat bran, winter wheat.....	12.3	37.1	2.6
Wheat shorts.....	12.2	50.0	3.8

Name of feed	Digestible nutrients in 100 pounds		
	Protein, pounds	Carbohy- drates, pounds	Ether extract, pounds
CONCENTRATES			
Wheat middlings.....	12.8	53.0	3.4
Wheat screenings.....	9.8	51.0	2.2
Bread crumbs.....	6.9	44.2	0.9
Rye.....	9.9	67.6	1.1
Rye bran.....	11.5	50.3	2.0
Rye shorts.....	11.9	45.1	1.6
Barley.....	8.7	65.6	1.6
Malt sprouts.....	18.6	37.1	1.7
Brewers' grains, wet.....	3.9	9.3	1.4
Brewers' grains, dried.....	15.7	36.3	5.1
Oats.....	9.2	47.3	4.2
Oatmeal.....	11.5	52.1	5.9
Oat feed or shorts.....	12.5	46.9	2.8
Oat dust.....	8.9	38.4	5.1
Oat hulls.....	1.3	40.1	0.6
Oats rolled, hulled, or pin-head..	15.0	66.6	8.0
Rice.....	4.8	72.2	0.3
Rice hulls.....	1.6	44.5	0.6
Rice bran.....	12.5	62.0	11.5
Rice polish.....	9.0	56.4	6.5
Rice meal.....	11.0	51.0	8.0
Buckwheat.....	7.7	49.2	1.8
Buckwheat hulls.....	2.1	27.9	0.6
Buckwheat bran.....	7.4	30.4	1.9
Buckwheat shorts.....	21.1	33.5	5.5
Buckwheat middlings.....	22.0	33.4	5.4
Milo maize.....	8.7	66.2	2.2

Name of feed	Digestible nutrients in 100 pounds		
	Protein, pounds	Carbohy- drates, pounds	Ether extract, pounds
CONCENTRATES			
Sorghum seed.....	7.0	52.1	3.1
Broom-corn seed.....	7.4	48.3	2.9
Kaffir corn.....	7.8	57.1	2.7
Millet.....	8.9	45.0	3.2
Feterita.....	9.3	66.6	2.5
Flaxseed.....	20.6	17.1	29.0
Linseed meal, old process.....	29.3	32.7	7.0
Linseed meal, new process.....	28.2	40.1	2.8
Cotton seed.....	12.5	30.0	17.3
Cotton-seed meal.....	37.2	16.9	12.2
Cotton-seed hulls.....	0.3	33.1	1.7
Cocanut meal.....	15.6	38.3	10.5
Palm nut meal.....	16.0	52.6	9.0
Sunflower seed.....	12.1	20.8	29.0
Sunflower-seed cake.....	31.2	19.6	12.8
Peanut in hulls.....	20.4	16.4	36.2
Peanut kernels.....	26.8	17.5	44.9
Peanut cake or meal from hulled nuts, fat extracted.....	42.8	20.4	7.2
Peanut cake or meal, hulls in- cluded.....	28.4	27.0	11.1
Peanut hulls.....	7.3	18.9	2.6
Rape-seed meal.....	25.2	23.7	7.5
Peas.....	16.8	51.8	0.7
Soy bean.....	29.6	22.3	14.4
Soy-bean meal (fat extracted)...	38.1	33.9	5.0
Cow-pea.....	18.3	54.2	1.1
Horse bean.....	22.4	49.3	1.2
Velvet bean meal (pods and bean).....	18.1	50.8	5.3

Name of feed	Digestible nutrients in 100 pounds		
	Protein, pounds	Carbohy- drates, pounds	Ether extract, pounds
ROUGHAGE			
<i>Fresh grass</i>			
Pasture grasses (mixed).....	2.5	10.2	0.5
Kentucky blue grass.....	3.0	19.8	0.8
Timothy, different stages.....	1.2	19.1	0.6
Orchard grass, in bloom.....	1.5	11.4	0.5
Redtop, in bloom.....	2.1	21.2	0.6
Oat fodder.....	2.6	18.9	1.0
Rye fodder.....	2.1	14.1	0.4
Sorghum.....	0.6	12.2	0.4
Meadow fescue, in bloom.....	1.5	16.8	0.4
Hungarian grass.....	2.0	16.0	0.4
Green barley.....	1.9	10.2	0.4
Peas and oats.....	1.8	7.1	0.2
Peas and barley.....	1.7	7.2	0.2
<i>Fresh legumes</i>			
Red clover, different stages.....	2.9	14.8	0.7
Alsike, bloom.....	2.7	13.1	0.6
Crimson clover.....	2.4	9.1	0.5
Alfalfa.....	3.9	12.7	0.5
Cow-pea.....	1.8	8.7	0.2
Soja bean.....	3.2	11.0	0.5
<i>Legume hay</i>			
Alfalfa.....	11.0	39.6	1.2
Cow-pea.....	10.8	38.6	1.1
Soja-bean straw.....	2.3	40.0	1.0
Pea-vine straw.....	4.3	32.3	0.8
<i>Silage</i>			
Corn.....	0.9	11.3	0.7
Clover.....	2.0	13.5	1.0
Sorghum.....	0.6	14.9	0.2

Names of feed	Digestible nutrients in 100 pounds		
	Protein, pounds	Carbohydrates, pounds	Ether extract, pounds
<i>Silage</i>			
Alfalfa.....	3.0	8.5	1.9
Grass.....	1.9	13.4	1.6
Cowpea vine.....	1.5	8.6	0.9
Soja bean.....	2.7	8.7	1.3
Barnyard millet and soja bean.....	1.6	9.2	0.7
Corn and soja bean.....	1.6	13.0	0.7
<i>Roots and tubers</i>			
Rape.....	2.6	10.0	0.3
Potato.....	0.9	16.3	0.1
Beet, common.....	1.2	8.8	0.1
Beet, sugar.....	1.1	10.2	0.1
Beet, mangel.....	1.1	5.4	0.1
Flat turnip.....	1.0	7.2	0.2
Rutabaga.....	1.0	8.1	0.2
Carrot.....	0.8	7.8	0.2
Parsnip.....	1.6	11.2	0.2
Artichoke.....	2.0	16.8	0.2
Turnip.....	1.0	6.0	0.2
MISCELLANEOUS			
Kale.....	1.9	4.7	0.3
Cabbage.....	1.8	8.2	0.4
Spurry.....	1.5	9.8	0.3
Sugar-beet leaves.....	1.7	4.6	0.2
Pumpkin, field.....	1.0	5.8	0.3
Pumpkin, garden.....	1.4	8.3	0.8
Prickly comfrey.....	1.4	4.6	0.2
Rape.....	1.5	8.1	0.2
Acorns, fresh.....	2.1	34.4	1.7
Brewer's grain, dried.....	21.5	30.5	6.1
Dried blood.....	52.3	0.0	2.5
Meat scrap.....	50.2	0.3	13.7
Dried fish.....	44.1	0.0	10.3
Beet pulp, dried.....	4.6	65.2	0.8
Beet molasses.....	9.1	59.5	0.0
Bone meal.....	26.0		
Cows' milk.....	3.6	4.9	3.7
Cows' milk, colostrum.....	17.6	2.7	3.6
Skim milk, gravity.....	3.1	4.7	0.8
Skim milk, centrifugal.....	2.9	5.2	0.3
Buttermilk.....	3.9	4.0	1.1
Whey.....	0.8	4.7	0.3

ARMSBY'S NET ENERGY VALUES FOR FEEDING STUFF

The following net energy values for the most important American feeds are taken from Armsby, Pennsylvania Bul. 142.

Feeding stuffs	Total dry matter, pounds	Digestible		Net energy value, therms
		Crude protein, pounds	True protein, pounds	
<i>Grains and seeds</i>				
Barley.....	90.7	9.0	8.3	89.94
Bean, navy.....	86.6	18.8	16.4	73.29
Buckwheat.....	87.9	8.1	7.2	59.73
Corn, dent.....	89.5	7.5	7.0	89.16
Corn, flint.....	87.8	7.7	7.2	87.50
Corn-and-cob meal.....	89.6	6.1	5.7	75.80
Cotton seed.....	90.6	13.3	11.9	78.33
Cowpea.....	88.4	19.4	16.9	79.46
Oats.....	90.8	9.7	8.7	67.56
Pea, field.....	90.8	19.0	16.6	78.72
Rye.....	90.6	9.9	9.0	93.71
Soybean.....	90.1	30.7	27.3	81.29
Wheat.....	89.8	9.2	8.1	91.82
<i>By-products</i>				
Buttermilk.....	9.4	3.4	3.4	13.32
Brewers' grains, dried.....	92.5	21.5	20.2	53.38
Brewers' grains, wet.....	24.1	4.6	4.4	14.53
Buckwheat bran.....	88.8	10.5	9.1	30.59
Cottonseed hulls.....	90.3	0.3	?	9.92
Cottonseed meal, choice.....	92.5	37.0	35.4	93.46
Cottonseed meal, prime.....	92.2	33.4	32.0	90.00
Cows' milk.....	13.6	3.3	3.3	29.01
Distillers' grains, dried, from corn.....	93.4	22.4	18.3	85.08
Distillers' grains, dried, from rye.....	92.8	13.6	11.1	56.01
Gluten feed.....	91.3	21.6	20.1	80.72
Gluten meal.....	90.9	30.2	28.1	84.15

ARMSBY'S NET ENERGY VALUES FOR FEEDING STUFFS (*Continued*)

Feeding stuffs	Total dry matter, pounds	Digestible		Net energy value, therms
		Crude protein, pounds	True protein, pounds	
Hominy feed	89.9	7.0	6.5	81.31
Linseed meal, new process	90.4	31.7	30.9	85.12
Linseed meal, old process	90.9	30.2	28.5	88.91
Malt sprouts	92.4	20.3	12.5	72.72
Molasses, beet	74.7	1.1	0.0	57.10
Molasses, cane, or blackstrap	74.2	1.0	0.0	55.38
Rye bran	88.6	12.2	10.5	79.35
Sugar-beet pulp, dried	91.8	4.6	0.7	75.87
Sugar-beet pulp, wet	9.3	0.5	0.5	8.99
Tankage, over 60 per cent. protein	92.6	58.7	55.6	93.04
Wheat bran	89.9	12.5	10.8	53.00
Wheat middlings, flour	89.3	15.7	14.0	75.02
Wheat middlings, standard	89.6	13.4	12.0	59.10
<i>Hay and dry, coarse fodder</i>				
Alfalfa hay, all analyses	91.4	10.6	7.1	34.23
Clover hay, alsike	87.7	7.9	5.3	34.42
Clover hay, red, all analyses	87.1	7.6	4.9	38.68
Corn fodder, medium dry	81.7	3.0	2.3	43.94
Corn stover, medium dry	81.0	2.1	1.6	31.62
Cowpea hay, all analyses	90.3	13.1	9.2	37.59
Millet hay, Hungarian	85.7	5.0	3.9	46.96
Oat hay	88.0	4.5	3.9	32.25
Red top hay	90.2	4.6	3.9	51.22
Soybean hay	91.4	11.7	8.8	44.03
Timothy hay, all analyses	88.4	3.0	2.2	43.02

AVERAGE COMPOSITION OF EGGS, EGG PRODUCTS, AND CERTAIN OTHER
- FOODS (European Analyses)

	Refuse, per cent.	Water, per cent.	Protein, per cent.	Fat, per cent.	Carbohydrates, per cent.	Ash, per cent.	Fuel value per pound, calories
Hen:							
Whole egg as purchased.....	11.2	65.5	11.9	9.3	0.9	635
Whole egg, edible portion.....	73.7	13.4	10.5	1.0	720
White.....	86.2	12.3	0.2	0.6	250
Yolk.....	49.5	15.7	33.3	1.1	1705
Whole egg boiled, edible portion.....	73.3	13.2	12.0	0.8	765
White-shelled egg as purchased..	10.7	65.6	11.8	10.8	0.6	675
Brown-shelled egg as purchased..	10.9	64.8	11.9	11.2	0.7	695
Duck:							
Whole egg as purchased.....	13.7	60.8	12.1	12.5	0.8	750
Whole egg, edible portion.....	70.5	13.3	14.5	1.0	860
White.....	87.0	11.1	0.03	0.8	210
Yolk.....	45.8	16.8	36.2	1.2	1840
Goose:							
Whole egg as purchased.....	14.2	59.7	12.9	12.3	0.9	760
Whole egg, edible portion.....	69.5	13.8	14.4	1.0	865
White.....	86.3	11.6	0.02	0.8	215
Yolk.....	44.1	17.3	36.2	1.3	1850
Turkey:							
Whole egg as purchased.....	13.8	63.5	12.2	9.7	0.8	635
Whole egg, edible portion.....	73.7	13.4	11.2	0.9	720
White.....	86.7	11.5	0.03	0.9	215
Yolk.....	48.3	17.4	32.9	1.2	1710
Guinea-fowl:							
Whole egg as purchased.....	16.9	60.5	11.9	9.9	0.8	640
Whole egg, edible portion.....	72.8	13.5	12.0	0.9	755
White.....	86.6	11.6	0.03	0.8	215
Yolk.....	49.7	16.7	31.8	1.2	1655
Plover:							
Whole egg as purchased.....	9.6	67.3	9.7	10.6	0.9	625
Whole egg, edible portion.....	74.4	10.7	11.7	1.0	695
Evaporated hens' eggs.....	6.4	46.9	36.0	7.1	3.6	2525
Egg substitute.....	11.4	73.9	0.3	5.3	9.1	1480
Pudding (custard) powder.....	13.0	2.1	3.4	80.9	0.6	1690
Cheese as purchased.....	34.2	25.9	33.7	2.4	3.8	1950
Sirloin steak as purchased.....	12.8	54.0	16.5	16.1	0.9	985
Sirloin steak, edible portion.....	61.9	18.9	18.5	1.0	1130
Milk.....	87.0	3.3	4.0	5.0	0.7	325
Oysters in shell as purchased.....	81.4	16.1	1.2	0.2	0.7	0.4	45
Oysters, edible portion.....	86.9	6.2	1.2	3.7	2.0	235
Wheat flour.....	12.0	11.4	1.0	75.1	0.5	1650
Potatoes as purchased.....	20.0	62.6	1.8	0.1	14.7	0.8	310
Potatoes, edible portion.....	78.3	2.2	0.1	18.4	1.0	385

As to the food value of eggs it may be said that one pound of eggs is more nutritious than a pound of steak. The only nonedible portion of the egg is the shell and outer membranes. In meat there is much bone and fiber of low food value.

AVERAGE OF DIGESTION COEFFICIENTS OBTAINED WITH POULTRY

Feed	No. of experiments	Organic matter	Crude protein	N. free extract	Ether extract
Bran, wheat.....	3	46.70	71.70	46.00	37.00
Beef scrap.....	2	80.20	92.60	95.00
Beef, lean meat.....	2	87.65	90.20	86.30
Barley.....	3	77.17	77.32	85.09	67.86
Buckwheat.....	2	69.38	59.40	86.99	89.22
Corn, whole.....	16	86.87	81.58	91.32	88.11
Corn, cracked.....	2	83.30	72.20	88.10	87.60
Corn meal.....	2	83.10	74.60	86.00	87.60
Clover.....	3	27.70	70.60	14.30	35.50
India wheat.....	3	72.70	75.00	83.40	83.80
Millet.....	2	62.40	98.39	85.71
Oats.....	13	62.69	71.31	90.10	87.89
Peas.....	3	77.07	87.00	84.80	80.01
Wheat.....	10	82.26	75.05	87.04	53.00
Rye.....	2	79.20	66.90	86.70	22.60
Potatoes.....	6	78.33	46.94	84.46	
Oats, rolled.....	1	84.00	81.00	84.80	86.20

WEIGHT OF VARIOUS CONCENTRATES

In computing rations for poultry it is desirable to know the weight per quart, or the bulk, of the different concentrates. The following table, compiled from *Massachusetts Bulletin* 136 by Smith and Perkins, *Louisiana Bulletin* 114 by Halligan, and *Indiana Bulletin* 141 by Jones, Haworth, Cutler and Summers is therefore presented.

Feeding stuffs	One quart weighs, pounds	One pound measures, quarts	Feeding stuff	One quart weighs, pounds	One pound measures, quarts
Whole corn.....	1.7	0.6	Millet, foxtail.....	1.6	0.6
Corn meal.....	1.5	0.7	Rice polish.....	1.2	0.8
Corn-and-cob meal.....	1.4	0.7	Rice bran.....	0.8	1.3
Hominy feed.....	1.1	0.9	Buckwheat.....	1.4	0.7
Gluten feed.....	1.3	0.8	Buckwheat flour.....	1.6	0.6
Gluten meal.....	1.7	0.6	Buckwheat middlings...	0.9	1.1
Germ oil meal.....	1.4	0.7	Buckwheat bran.....	0.6	1.7
Corn bran.....	0.5	2.0	Buckwheat hulls.....	0.5	2.0
Wheat.....	1.9	0.5	Cotton seed.....	0.8	1.3
Wheat, ground.....	1.7	0.6	Cottonseed meal.....	1.5	0.7
Flour wheat middlings...	1.2	0.8	Cottonseed hulls.....	0.3	3.3
Standard wheat middlings	0.8	1.3	Flaxseed.....	1.6	0.6
Wheat bran.....	0.5	2.0	Linseed meal, old process	1.1	0.9
Wheat feed (shorts and bran).....	0.6	1.7	Linseed meal, new pro- cess.....	0.9	1.1
Wheat screenings.....	1.0	1.0	Flax feed.....	0.8	1.3
Rye.....	1.7	0.6	Flax screenings.....	1.1	0.9
Rye meal.....	1.5	0.7	Beans, navy.....	1.7	0.6
Rye middlings.....	1.6	0.6	Cowpeas.....	1.7	0.6
Rye bran.....	0.8	1.3	Peas, field.....	2.1	0.5
Rye feed (shorts and bran).....	1.3	0.8	Soybeans.....	1.8	0.6
Oats.....	1.0	1.0	Cocoanut meal.....	1.5	0.7
Oatmeal.....	1.7	0.6	Cocoanut cake.....	1.3	0.8
Oats, ground.....	0.7	1.4	Sunflower seed.....	1.5	0.7
Oat feed.....	0.8	1.3	Beet pulp, dried.....	0.6	1.7
Oat middlings.....	1.5	0.7	Distillers' grains, dried..	0.6	1.7
Oat hulls.....	0.4	2.5	Molasses, cane, or black- strap.....	3.0	0.3
Barley.....	1.5	0.7	Molasses feed.....	0.8	1.3
Barley meal.....	1.1	0.9	Alfalfa meal.....	0.6	1.7
Malt sprouts.....	0.6	1.7			
Brewers' grains, dried....	0.6	1.7			

CHAPTER XVI

DISEASES CONNECTED WITH FEED

SPOILED AND DISEASED FEEDS

MANY digestive derangements are caused through dietetic errors caused by spoiled feeds. It is a common and popular thought that spoiled feed, not fit for human consumption, is good enough for the chickens. Food that is injurious to the digestive canal of one group of animals is pretty likely to prove just as injurious to another. There are very few exceptions to this rule. The fact that a buzzard can eat carrion and thus spread disease does not imply that all kinds of birds can eat spoiled feed with impunity. The anatomic and microscopic structure of the digestive tract of all animals is pretty much alike, as we may see under the section on Digestion. All animals make use of the same nutrients, assimilate them, and build organic structures out of them. So far as we know, fat in the body of a hen is built up by the same process as fat in the body of a cow or a human. Its sources may be the same. All eat similar food—that is, the same kind of carbohydrates, hydrocarbons, protein, and ash. All are affected in a similar manner when poisonous substances are taken into the body. Some withstand certain poisons better than others. It was formerly thought that it was impossible to poison birds with strychnin, and one author went so far as to say that pigeons ate strychnin with impunity, but that birds can easily be poisoned by strychnin is shown by the experiments of the author, in which experiments the medicinal dosage of sulphate of strychnin was found to be from $\frac{1}{8}$ to $\frac{1}{4}$ grain to an adult hen. One grain in solution, given on an empty stomach, always proves fatal in a very few minutes. Therefore, birds have a greater resistance to strychnin per body weight than other animals, making the medicinal dose greater, and hence the lethal or poisonous dose correspondingly larger.

Birds readily succumb to ptomain-poisoning after eating rotten meat. Birds have been known to suffer from ptomain-poisoning after eating putrid canned corn.

While the intestinal flora or bacteria which live in the digestive tract is somewhat similar to that of higher animals, yet they do not apparently suffer to any great extent with fermentation of the undigested food and with tympany. The carcass of a horse, cow, dog, or hog, in many instances, and especially in cases in digestive derangements, soon "bloat" to enormous size. This bloating does not readily take place in dead fowl, if at all. There appears to be no fermentative trouble from digestive contents in dressed carcasses of fowl. Fermentation and putrefaction is indeed slow, though it cannot be disputed that if the carcass be kept under the proper temperature the germs or bacteria from the intestinal tract grow by extension through the intestinal wall, and ultimately contribute to degenerative changes as well as products given off by them in solution spreading by diffusion. This change, however, is slow if the carcasses be kept at a cool temperature (below 40° F.).

In studying feeds and digestion, we take under consideration the possible alteration in quantity, conditions of quality, and conditions of digestibility.

An excess of certain kinds of food, without sufficient exercise, may lead to a physiologic deposition of fat, especially in the abdominal cavity, which may interfere from two standpoints—namely, egg production and as breeders, affecting fertility and vitality of the progeny. As a pathologic result it may produce a febrile condition with blood and liver derangements, especially when the excess is protein.

Spoiled feed may be of such a nature as to cause diarrhea by acting as an irritant to the intestinal mucosa. The diarrhea is a natural result of nature, the intestinal canal trying to rid itself of the objectionable material.

When feed is kept for a considerable length of time and under certain conditions it may be attacked by vegetable and animal organisms. Thus, mash, bran, middlings, and shorts kept in too damp a quarter are readily attacked by molds and saprophytic bacteria of decay, and the feed soon becomes bitter and

spoiled and unfit for feeding. (See Fig. 104, *a*, *b*, *c*, and *d*.) Weevil is another enemy of feed, especially grain. Rats and mice destroy large quantities. The storage-rooms should be made and maintained rat- and mouse-proof, and the grain bins and mash hoppers in the poultry houses should be kept closed at night. It is good practice to have the mash hopper in the hen-house so constructed that the lid may be closed in the evening when the evening scratch feed is given, and again opened when the morning scratch feed is given; thus it takes no extra time to see that this precaution in feed saving is carried out.

As hinted before, the quality of feed is affected by its mode of growth, care in saving and preservation, as well as cleanliness, and the inroads of vegetable and animal parasites.

If grain be grown on land that is poor in quality, the product will also be poor in quality. Therefore the quality of the soil affects the quality of the crop. It has been noticed that oats grown on clay soil are superior to any other. Rye grows best on light sandy soil and barley on good loam. The age at which the crop is gathered is also an important factor exerting its influence upon the nutritive value.

Wheat cut about fifteen days before it is ripe contains the most protein and starch and the bushel measureful weighs more. If it be cut late, there is found a less percentage of the floury part and an increase in the percentage of bran. The season has a great influence on the quality of feed, wet years producing parasitic diseases of the grain and stalk, and the crop is usually delayed in maturing. It is noticed that in a wet, hot summer ergot of the seeds of grains and grasses, especially rye and blue grass, is more common.

There are certain chemical changes that take place in grain after it is stored which apparently removes any irritating properties it may contain, and renders its nutritive substances easier digested. This not only applies to grain, but to mangles and even hay.

Food improperly taken care of in wet seasons may deteriorate, that is, become moldy, and chemical changes of various kinds take place, affecting both the proteins and starches, and at times rendering them unfit for food and even poisonous.

The risk which one takes in feeding any foodstuff which has kept badly depends upon the extent to which deterioration has taken place. The degree to which the food is damaged may range from a faint moldy smell to a decomposing and offensive-smelling material.

Root-crops, under the conditions usually kept, may readily undergo decay. Rotten potatoes and other roots may produce digestive irritation and even poisoning.

Cleanliness in feeding is essential.

Baby chicks sometimes gorge themselves with sand, impaction of the crop being the result, and death often follows.

DISEASES OF FEED

Certain fungi attack plants during growth, and thus may be considered parasites of that plant.

Those organisms which attack the grain or plant after death or at maturity are called saprophytes.

Some organisms attacking foodstuffs are vegetable in nature, while others are animal organisms.

The organisms here considered destroy the grain on which they live.

The principal vegetable parasites are those causing ergot, rust, smut, and mildew. (See Fig. 104, *i*, *j*, and *k*.)

Those attacking plants and grain after death or at maturity cause moldiness and rotteness, and these molds belong to the genera of *aspergillus*, *penicillium*, and *mucor*, besides many kinds of saprophytic bacteria. (See Fig. 104, *a*, *b*, *c*, and *d*.)

Puccinia graminis is the fungus which under certain conditions attacks growing grain. It must necessarily pass through two hosts or plants to complete its life cycle. In each host it produces a distinct disease. The stems and leaves of all grasses and cereals may be attacked by it in the early summer. On these it produces yellowish-red lines or spots. The color is due to the spores or seeds of the fungus. This material when dry is dust-like, and gives the rusty appearance to the leaf or stalk attacked. The mycelia or mass of hyphæ are composed of elongated cells, arranged end to end, and grow

into the substance of the leaf or stalk. The spores they form are called uredospores. Later in the summer the production of yellowish-red spores ceases and changes take place in the mycelia, when, instead of yellowish-red spores, there is now formed another kind, known as the teleutospore, and is not capable of producing the disease if placed on a fresh plant.

It must undergo another change in which a small hyphæ-like outgrowth is formed and which bears four spores; this is the third kind of spore produced in the cycle. These latter spores may be transmitted by the wind to other plants, where the fungus again repeats its cycle.

Smut of corn is produced by a fungus, *Ustilago maydis*, and is said to be non-poisonous. *Ustilago carbo* is the fungus that produces smut of oats. (See Fig. 104, *j*.) This fungus consists of mycelia and spores. The flowering heads of grains, as wheat, oats, rye, and barley, may be attacked. The diseased area appears at first as a small whitish spot which, after the spores have formed, appears black. This fungus completely destroys the flowering head and seed.

Claviceps purpurea is a fungus which attacks the grains of grasses, as blue-grass and grains of rye. (See Fig. 104, *k*.) The grain becomes enlarged to twice or more in length, and varies from a brown to black in color. The attacked grain is known as an ergotized one.

Grain and mash exposed to sufficient dampness become moldy. Figure 104, *a, b, c, d*, illustrates various kinds of bacteria and molds, as stated before. The latter are made of hyphæ and spores.

Damp grain becomes dark in color and sprouts; the starch is changed into sugar, and other chemical changes take place, besides some of the nutrients are used up by the mold. Fermentation of the mass raises the temperature and, if much bulk, becomes quite hot to the hand.

As soon as it is found that feedstuff becomes wet, it is advisable to spread it out in a thin layer so that it can readily dry and thus produce unfavorable conditions for the growth of the fungi. A dry place is essential for the storing of feedstuffs. While the drying prevents sprouting, stops the fungoid growth,

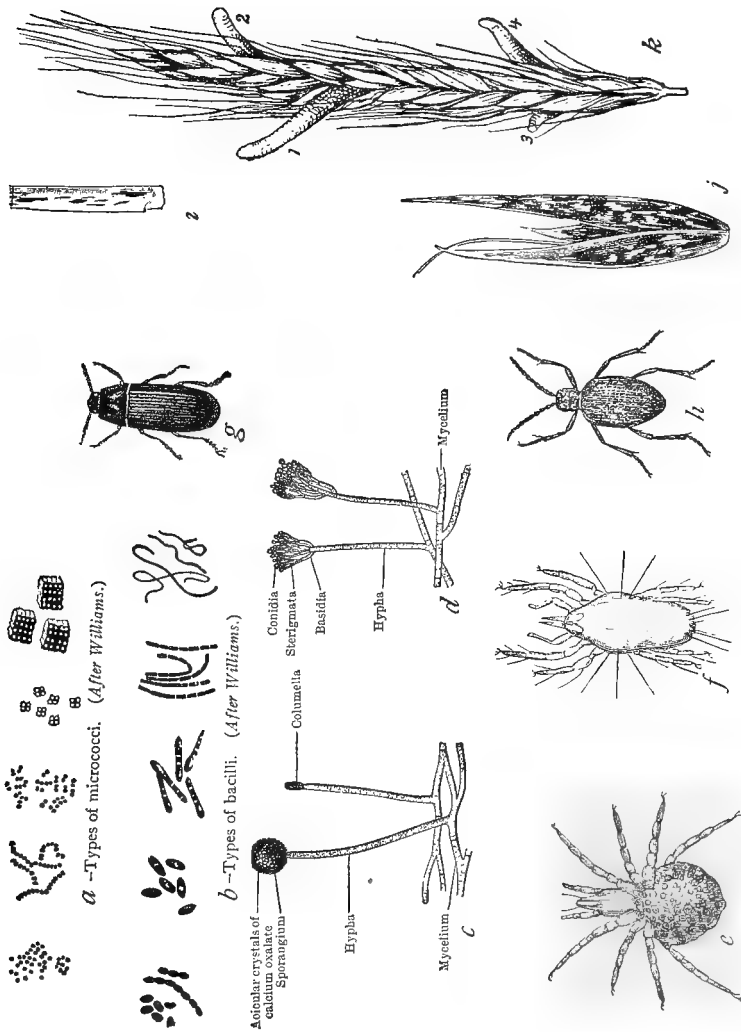

FIG. 104.—A chart of parasites and foodstuffs: *a* and *b* are germs that cause decay, and *c* and *d* are molds which attack and destroy feed when the proper moisture and heat is present; *e*, *f*, *g*, *h* are bugs which attack the grains; *i* is a stalk of oats attacked by rust; *j* an oat head attacked by smut; *k* a rye head attacked by the fungus of ergot and showing the ergot grains at 1, 2, 3, 4.

and gets rid of the moisture, yet one should be apprehensive about feeding such spoiled feed.

There are two kinds of animal parasites affecting grain, as mentioned before. One attacks the grain during growth and development, the other the cured grain. Thus, the ear of corn is attacked by a worm, and wheat, rye, and oats by the ear cockle, another kind of round-worm.

The insects attacking cured grains are the *Tenebrio forma*. The larva of the Tenebrio of grain destroy the grains, reducing them to a powder. Certain acari also destroy grain, among which are the Gamasus and Argas. (See Fig. 104, *f, g, h.*)

The *acari* (Fig. 104, *e*) reduce the grain content to a powder, consuming a part and contaminating the balance with their excrements and destroying it.

Birds are capable of eating many kinds of insects and worms, and while some of these when ingested by other animals suffer, it is not proved that they are harmful to birds.

CHAPTER XVII

RATIONS AND METHODS OF FEEDING

THE object of feeding is to transform the vegetable and animal feeds into finished products in the form of eggs and meat which are edible, and to keep the body in a normal physiologic condition.

The different processes in the body to be considered are growth, reproduction, storing of fat, maintenance of the body temperature, repair of body tissue waste, to supply muscular energy, and the elaboration of secretions.

A chick develops or grows very rapidly if given proper food.

The baby chick is one of the most delicate animals, and is capable of making the most rapid growth of any. The baby chick at hatching weighs about $1\frac{1}{2}$ ounces. By proper care and feed the chick should weigh 40 ounces at twelve weeks old, or an increase of approximately twenty-six times its original weight. Therefore, the process of digestion and assimilation is much greater than in other animals. Cell metabolism is very rapid. A chick requires a large amount of mineral matter, as lime-salts, as well as much protein, hence it requires a narrow ration. The greatest primary increase is in bone and muscle. The bony structure is the framework for the support of the reproductive and other vital organs and attachment for the skeletal muscles. Many of the hollow organs, as the bowels, contain muscular coats, which are composed largely of albumen. This albumen is built up from the protein of the food, and the same may be said of the skeletal muscles and of the cells of the glands. The muscular structure is called lean meat. Protein is the nitrogen-containing portion of the food.

As a result of rapid growth and development the bird must be supplied with food containing much protein. Body development or growth is largely completed when egg production or egg formation begins.

The length of time for a bird to reach the age of full development, as far as skeleton and muscle is concerned, varies with the care, feed, and breed. If the birds are properly fed the smaller breeds, as those belonging to the Mediterranean—namely, the Leghorn and Minorca—will be sufficiently developed to lay at about five months of age, while the larger breeds, as the Asiatics and American—namely, the Cochins, Plymouth Rocks, and Wyandottes—may not lay till they are six or even seven months old.

The workers at Cornell have determined by careful observations that a young bird molts four times before growing its permanent adult feathers and does not lay till adult plumage is developed.

The late molting hen is the heavy layer and it is therefore advisable to select the late molter for breeding.

S. C. White Leghorn pullets force fed from baby chick to maturity have laid at four months and four days to five months of age.

In selecting hens for breeding one should take only the heavy layers if increased egg production is desired. An average-sized egg weighs about 2 ounces. Of this, 11 per cent. is shell, 32 per cent. is yolk, and 57 per cent. is white. The principal chemical constituents are ash or mineral matter, which constitutes 9 per cent.; fat or hydrocarbon, $9\frac{3}{10}$ per cent.; proteins or nitrogenous-containing substance, $11\frac{9}{10}$ per cent.; water, $65\frac{5}{10}$ per cent.

Calcium, or lime-salts, is essential for the formation of the egg-shell. As the feeds commonly fed to poultry do not contain sufficient lime, it is necessary to feed shell, as oyster-shell, unless the birds are on range where they have an opportunity to pick up lime.

Foods consist of three organic compounds as follows: Protein, carbohydrates, and hydrocarbons. Protein contains the following elements—carbon, hydrogen, oxygen, nitrogen, and sulphur. All the nitrogen of the foodstuffs is contained in the protein. The carbohydrates contain three elements—namely, carbon, hydrogen, and oxygen—and include the starches, sugars, gums, resins, and other similar substances.

The third compound, the hydrocarbons, are composed of

three elements, carbon, hydrogen, and oxygen, and include the compounds, fats and oils. In addition to these three compounds we find water and ash or mineral matter, representing the inorganic compounds.

The egg, as stated before, contains a large amount of albumen or nitrogen-containing substances, which must be built up from the protein constituents of the food. The same may be said of a growing animal, hence feeds for these animals must contain considerable protein. Therefore, oats and wheat in different forms, as well as meat scrap and green feeds, make up the greater protein content of these rations which give the best results in egg production and growth and development.

In mature birds, where it is the desire to finish them—that is, fatten them for market—it is necessary in order to obtain the best results to feed a ration containing much carbohydrates and hydrocarbons.

To summarize, we might say that the protein, or nitrogen-containing compounds of the food, repairs the body-waste caused by exercise and living processes, as that brought about by the beating of the heart and by respiration. The carbohydrates and hydrocarbons or starches and fats are utilized in the body for combustive purposes for the production of energy and to keep up the body temperature. Any nutrients in excess of the body requirements to make good tissue-waste are stored up as fat or go for egg production.

FOR LAYING HENS

To secure a goodly number of eggs it is necessary to make the proper selection of hens. In breeding, one should select for longevity, use late molters, select early producing pullets, use fall and winter layers, select heavy eaters, early risers, and late retirers, and procure mature birds. Pullets for fall laying should be hatched the first week in April. It pays to keep pure bred poultry because they are more reliable in breeding. They are greater egg producers, superior in meat quality. With pure bred one should secure better results in feeding, better hatching quality, less broodiness, more attractive appearance, and a more uniform egg in size, shape, and color.

Breeding stock can be sold at a higher price than butcher stuff. In order to build up a greater egg-laying strain trap nests are resorted to, and those showing a high egg-laying record are used to breed from. Male birds from these high-laying strains should be used, as inheritance of high egg-producers is also transmitted to the offspring by the male.

An important factor in the success of winter egg production is the manner in which the pullets are started out in the fall. The young pullets that are expected to lay the high priced eggs in the fall and winter should be properly housed in their permanent winter quarters as soon after September 1st as possible, and with the least possible excitement accompanying this moving. New surroundings always occasion a setback in pullets just entering the laying age. The set back is more pronounced in the nervous, active breeds as the Leghorns than the heavy sluggish breeds. Decker relates an experience in which 60 White Plymouth Rock pullets were moved twice after September 1st, the last time being on October 10th. These pullets did not settle down to laying till after Christmas, whereas others of the same age and breed that had not been moved were laying regularly by November 1st. Some commercial egg producers shut their pullets in the house all fall, winter, and spring, force feed them for laying, and sell them in the summer when the eggs are a low price, and again take on a new lot of pullets raised that year. The youngsters are raised on range, and when it is time to take them to their new quarters they are fed gradually closer to their permanent house, are finally enticed into the house where they soon begin to feel at home, and roost at night. Finally when there is no danger of disturbance from closing the doors, they are shut up and there remain for the winter.

It is very important that the young pullets receive an abundance of green feed daily after they are confined in the laying house. This green feed may be cabbage leaves, lettuce, second growth clover clippings, sprouted oats, green corn blades and stalks cut fine, sweet corn planted closely and stalks thus grown cut finely in feed cutter. Lettuce may be planted each week from as early in the spring as it will grow to as late in the fall. In the South it may be grown all year round.

The pullets need an abundance of lime as the stronger the shells the fewer will be broken when shipping to market and the less loss to the producer. Then the pullet needs lime to complete growth. Three pounds of oyster shell, ground to a fine powder, added to each 100 pounds of mash has proven beneficial.

An Estimate of Possible Production.—The Dominion of Canada gives the following summary: It may be of interest to outline what might be considered reasonable winter production in Canada from a flock of strong, vigorous, well-matured pullets intelligently housed, fed, and cared for. The figures indicated are percentages figured on the number of eggs laid per day in proportion to the total number of pullets in the flock:

October from $\frac{1}{2}$ per cent. to 5 per cent.

November from 5 per cent. to 15 per cent.

December from 15 per cent. to 20 per cent.

Usually there is a slight falling-off early in December when the extreme cold weather commences; this shrinkage, however, is usually overcome as soon as the birds become accustomed to the changed conditions.

January from 20 per cent. to 40 per cent.

February from 20 per cent. to 30 per cent.

The figures for February would be high in many cases, for birds that have laid well during the previous three months usually show quite a marked falling-off in February, evidently a provision of nature to prepare for the stress of the natural hatching season to follow:

March from 35 per cent. to 55 per cent.

April from 55 per cent. to 70 per cent.

The period of highest production comes usually between the middle of March and the middle of April. The most valuable bird, however, is the one that lays in her pullet year thirty or more eggs before the first of March.

Farm range conditions are best for health, vigor, and strong progeny. The food obtained from range consists of worms, slugs, insects, seeds, green feed, lime, various salts, and small sharp stones.

Hot mashes at night in the winter time in which is incorpo-

rated green feed, milk, and meat scrap stimulate winter egg production.

Laying hens should be kept warm and protected from storms.

To keep the hens happy they should have about a foot of wheat or oat straw in the bottom of the houses, into which the scratch feed should be thrown. It is necessary to keep the birds free of lice and chiggers. Vermin weaken birds and lay them open to attacks of disease, and are indirectly the cause of more loss from death, egg production, and flesh than any other one cause.

The birds should not be frightened by strangers and dogs, etc., entering the premises.

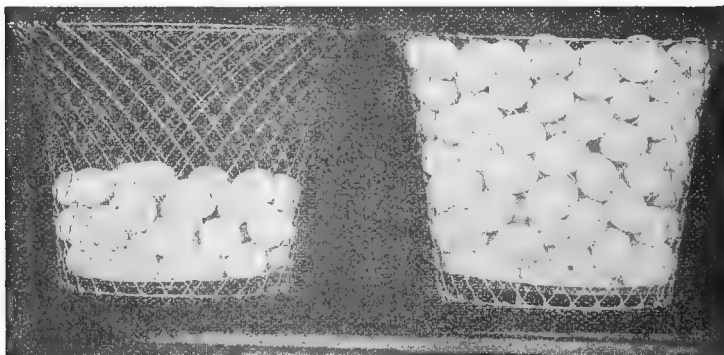

FIG. 105.—A comparison of the number of eggs laid by a scrub (75) and a hen bred for high egg production (224).

For laying hens the following feeding program should be carried out: The first scratch feed should consist of clipped oats and wheat, of each equal parts, and should be given at about 7 o'clock in the morning and thrown in the litter, so they will have to scratch for it. The second scratch feed should consist of clipped oats, wheat, and the coarse particles of cracked corn, equal parts, and should be given at about 3 o'clock in the afternoon and placed in the straw.

Dry mash should be kept in slatted hoppers in such a way that they cannot throw it out, and this feed should be kept before them at all times. This dry mash should consist of the following:

Wheat bran.....	2 parts.
Wheat middlings.....	2 "
Ground oats.....	2 "
Cornmeal.....	1 part.
Cotton-seed meal.....	1 "
Meat scrap.....	1 "
Ground alfalfa.....	1 "
Thoroughly mix.	

In addition to this, skimmed milk, clabber, or buttermilk may be given. It has been found that milk will, at least to a certain extent, take the place of the meat scrap.

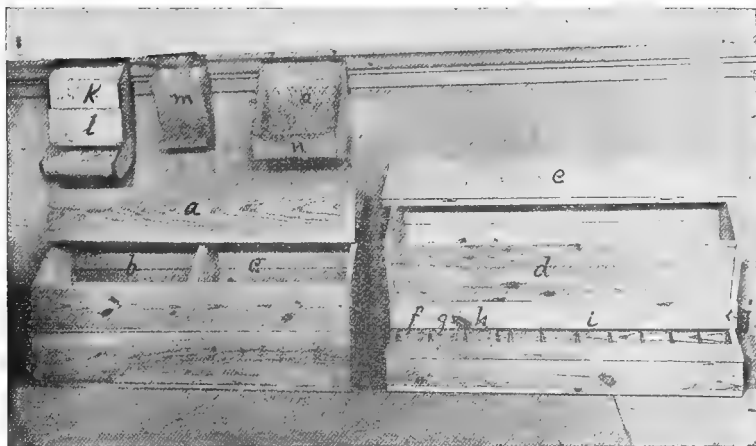

FIG. 106.—*a* is a grain storage box to be kept in the hen house for storage of the grain feed; *b* for the morning scratch feed, *c* for the evening scratch feed; *d* is an inside dry mash hopper; *e*, the lid; *f*, compartment for grit; *g*, compartment for charcoal; *h*, compartment for oyster shells; *i*, compartment for the dry mash; *j*, the let-down lid so the rats cannot eat the mash at night; *k* is a commercial mash hopper; *l*, the let-down lid; *m* is a three-compartment mash or shell hopper; *n* is a metal mash hopper; *o*, a netting over the mash to prevent the birds from throwing the feed out.

It is convenient to have in each hen house a grain storage box, as illustrated in Fig. 106, *a—b* is the compartment for the storage of the morning scratch feed and *c* for the evening scratch feed. The lid is up to show the interior; *d* represents a dry mash hopper which should be provided for the interior of every hen house; *e* is the lid; *f*, the compartment for oyster

shells; *g*, the compartment for grit; *h*, the compartment for charcoal; *i*, the compartment for the dry mash; *j*, indicates the lid, which may be closed down at night, thus keeping out the rats and mice; *k* is a commercial metal mash hopper; *l* is a lid to let down at night; *m* is another mash hopper with three compartments, and is excellent for chicks or bantams; *n* is still another type of mash hopper, with *o*, a grating to keep the fowl from throwing out the mash.

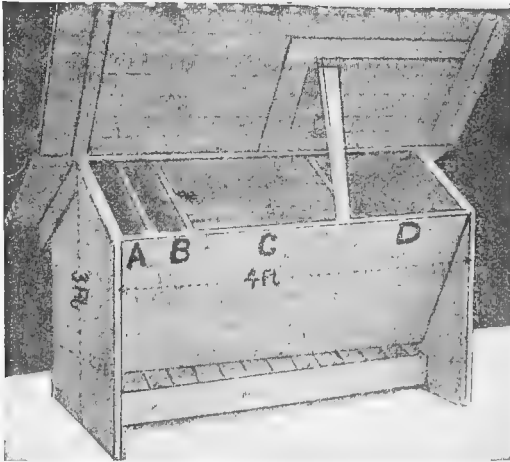

FIG. 107.—An outdoor mash hopper. The four compartments *A*, *B*, *C*, and *D* are for use as in Fig. 106, *d*. The dimensions are given on the box. It is covered with rubberoid.

The New Jersey Experiment Station recommends the following ration for laying hens, in their Bulletin No. 2, vol. i, 1912:

DRY MASH

Wheat bran.....	200 pounds,	380 quarts.
Wheat middlings.....	200 "	240 "
Ground oats.....	200 "	200 "
Cornmeal.....	100 "	95 "
Gluten meal.....	100 "	80 "
Meat scrap.....	100 "	86 "
Short-cut alfalfa.....	100 "	200 "
	<u>1000</u> pounds,	<u>1381</u> quarts.

By referring to the table of digestible nutrients and adding up the fat, multiply this by 2.25 and add it to the carbohydrates, and divide this by the amount of protein, it will be found that the nutritive ratio will be 1 : 3.02.

MORNING SCRATCH FEED

Wheat.....	200 pounds,	53 quarts.
Clipped oats	100 "	98 "
	<u>300 pounds,</u>	151 quarts.
Nutritive ratio, 1 : 6.6.		

NIGHT SCRATCH FEED

Cracked corn.....	200 pounds,	120 quarts.
Wheat.....	100 "	53 "
Clipped oats.....	100 "	98 "
Buckwheat.....	100 "	66 "
	<u>500 pounds,</u>	337 quarts.
Nutritive ratio, 1 : 7.8.		

Another feed for laying hens, which has been recommended by the Poultry Review, is as follows:

MORNING SCRATCH FEED

Oats.....	320 pounds.
Wheat.....	60 "
Buckwheat.....	24 "
Millet.....	50 "
	<u>454 pounds.</u>
Nutritive ratio, 1 : 6.02.	

EVENING SCRATCH FEED

Cracked corn.....	100 pounds.
Wheat.....	60 "
Oats.....	64 "
Buckwheat.....	48 "
Rye.....	56 "
	<u>328 pounds.</u>
Nutritive ratio, 1 : 7.7.	

The Ohio Experiment Station recommends the following ration for laying hens:

WINTER SCRATCH FEED

Cracked corn.....	60 pounds,	36 quarts.
Wheat.....	40 "	21 "
Heavy oats.....	20 "	20 "
	<u>120</u> pounds,	<u>77</u> quarts.

Nutritive ratio, 1 : 8.3.

SUMMER SCRATCH FEED

Wheat.....	60 pounds,	32 quarts.
Cracked corn.....	40 "	24 "
Heavy oats.....	20 "	20 "
	<u>120</u> pounds,	<u>76</u> quarts.

Nutritive ratio, 1 : 8.5.

DRY MASH

Cornmeal.....	100 pounds,	90 quarts.
Wheat middlings.....	150 "	189 "
Wheat bran.....	100 "	190 "
Meat scrap.....	100 "	190 "
Linseed oil meal.....	25 "	18 "
Alfalfa meal (fine).....	25 "	45 "
Charcoal.....	8 "	11 "
Salt.....	2 "	1 "

510 pounds, 590 quarts.

Nutritive ratio, 1 : 2.7.

In regard to the method of feeding, they say:

"In addition to above give grit and oyster-shell, green feed—mangles, rape, cabbage, kale, sprouted oats, etc., and water.

"In the morning, feed, in a deep litter of straw, a sufficient quantity of grain to keep the hens busy for an hour or two. The exact quantity to feed will depend on the size, number, and appetite of the flock. Provide plenty of fresh water—cold in summer and warm in winter.

"At noon give enough green feed to satisfy each hen. If the hens have a tendency to fatten, scatter a handful or two of grain in the litter. This will encourage the hens to exercise and to fatten less readily. Open the dry mash hopper during the afternoon so that the hens may help themselves. Leghorns, Hamburgs, and Minorcas may have access to the dry mash at all times, but Plymouth Rocks, Wyandottes, Orpingtons, and Rhode Island Reds will often become too fat if allowed the same freedom.

“Late in the afternoon give the hens a good feed of grain in the litter. Endeavor to feed sufficient grain so that each hen will go to roost with a full crop. If a little grain remains in the litter, it will be scratched out early in the morning and keep the hens busy until feeding time. However, only enough grain should be fed to keep the appetite of the flock keen. The action of the hen is the best guide in this respect. Experiments have shown that the most economic production of eggs is attained when the hens consume twice as much grain as dry mash, and that a hen will require from 75 to 90 pounds of grain and mash a year.

“Grit and shell should be provided in open hoppers.

“Skimmed milk may be fed in pans, as a substitute for part of the meat scrap in the dry mash. The pans should be scalded occasionally. Sour milk is safest and best throughout the year, but avoid changing from sour to sweet or vice versa.

“Feed regularly and at the same hour every day. Examine a hen occasionally and note the condition of her body.”

The Massachusetts Experiment Station recommends the following ration for laying hens:

Prof. Graham says: “There are about as many methods of feeding poultry as there are poultrymen, and yet there are perhaps more questions asked regarding this subject than any other. It is a well-known fact that one can feed almost any ration to hens and get good results for a time, provided he feeds enough of it; but to feed in such a way that the hens will be strong and vigorous and have good appetites, and to get the most possible for the amount of feed and labor expended, is another question. In other words, the time has come, with our high-priced feed, when we must feed as economically as possible.

“Good results can be obtained by feeding a grain ration and balancing it with milk. A good ration for this method of feeding is 2 parts cracked corn, 1 part wheat, and 1 part oats. In addition to this, by giving the hens all the milk they will drink, enough protein will be furnished so that they can balance their own ration.

“This ration can be varied, substituting beef scrap for milk. The beef scrap can be fed in a hopper, and if the hens are in-

clined to eat too much of it the hopper can be closed a part of the day. It can also be varied by substituting barley and buckwheat for corn and wheat respectively where these grains are available. A great variety of grains, such as we find in commercial scratch feeds, can be fed and balanced by feeding either milk, beef scrap, or green cut bone."

"Ration No. 2, Combination ration (grains and dry mash).

"This is perhaps the most popular ration used in feeding poultry at the present time. In feeding this ration one can give a greater variety, utilize waste products and concentrates, can determine more nearly the amount eaten, utilize bulky materials, prevent waste, and stimulate the hens.

"The disadvantages of a dry mash are that we are apt to get the mash too rich, too bulky, or get too much fibrous material in it, and if the hoppers are not constructed properly there will be more or less waste. It is not forcing, and birds must be taught to eat it. The advantages of a dry mash over a wet mash are that it saves labor, avoids decomposed materials, can be eaten when desired, perhaps at leisure, and is more sanitary."

The grain used in this ration are the same as in ration No. 1, and the two following formulæ for dry mashes are recommended:

Mash No. I

Wheat bran (by weight).....	2 parts.
Wheat middlings.....	1 part.
Cornmeal.....	1 "
Alfalfa (ground).....	1 "
Beef scrap.....	1 ₂ "
Oil meal.....	1 ₂ "
Gluten meal.....	1 ₂ "

Nutritive ratio, 1 : 3.4.

Mash No. II

Wheat bran.....	1 part.
Wheat middlings.....	1 "
Cornmeal.....	1 "
Finely ground oats.....	1 "
Beef scrap.....	1 "
Oil meal.....	1 "
Gluten feed.....	1 "

Nutritive ratio, 1 : 2.6.

The Pennsylvania Experiment Station says: "There never can be a balanced ration that will hold for all sorts and conditions of laying hens. Flocks differ as to age, development, breed, manner of housing, etc.

"Of the different grains corn is the most fed, but it is a fat- and heat-producing food and should be always so viewed. The great problem in open-front houses is to keep Leghorns in them from 'pouting' in very cold weather, and there is no one grain that we have that will so cheaply and effectually keep a Leghorn pullet warm and happy as corn. Corn is the grain most greedily eaten by chickens, and because of its size they can quickly fill up. This and its make-up has a strong tendency to make hens fed heavily on it overfat. From a close study it must be said that hens relish corn merely on account of its size. When cracked it seems to have no special attraction over other grains, and allows them to eat it the same way, two reasons why corn should always be fed only as cracked corn. Wheat is the one best chicken grain, and yet if one grain and one only is to be fed corn turns out to be better than wheat. Good heavy oats rank next to wheat. Light oats and barley are a delusion, and have so much fiber that a hen will waste a lot of good value getting rid of it, or she can eat enough only to keep herself going and perhaps do a little at laying besides.

"Too many scratch feeds contain much of this stuff, besides shrunken wheat, poor buckwheat and a lot of corn-hulls, etc. Some kaffir and sunflower seeds are added, the whole put up to sell at a low price to meet competition. A hen to do heavy laying must have a large amount of the cleanest, soundest grain, the hardest red wheat and the plumpest oats, and the cleanest, soundest cracked corn. This is very much the cheapest to buy.

"Formula for home-mixed scratch feed for Leghorns in cold weather:

Cracked corn.....	400	pounds.
Wheat.....	300	"
Hulled oats.....	100	"
Buckwheat.....	100	"
Whole oats.....	50	"
Pearl millet.....	50	"

Nutritive ratio, 1 : 7.6.

“Leghorns, being dainty feeders, never take readily to whole oats, no matter how heavy they are, and hence we feed the minimum amount. But with warm weather we reverse the position of the corn and wheat and substitute, if possible, some part kaffir corn.”

The following formula is suited for large pullets of the Plymouth Rock and Wyandotte classes for cold weather:

Cracked corn.....	200 pounds.
Wheat.....	400 “
Hulled oats.....	100 “
Whole oats.....	200 “
Buckwheat.....	50 “
Pearl millet.....	50 “

Nutritive ratio, 1 :7.2.

The Mississippi Experiment Station recommends the following rations for laying hens:

“The ration used throughout the winter months was composed of equal parts oats, wheat screenings, and corn. The grain was fed in the straw with which the floor was covered and the hens were forced to scratch for it. Grit, charcoal, and oyster-shell were kept before them.

“The yards are partitioned, oats sown in them early in the spring, and as soon as the stand is large enough the hens are allowed to graze on it. The green feed during the winter is rape. A small patch is sown in the early part of the season and a small amount is thrown into them each day.

“The mash feed along with the above scratch feed as recommended is as follows:

Cornmeal.....	50 pounds.
Wheat bran.....	10 “
Cotton-seed meal.....	10 “
Oats.....	30 “

Nutritive ratio, 1 :6.

If it is not the desire to entail the detailed work as outlined above, but to have more simple rations, though the results may not be so satisfactory, then the following plan may be followed for laying hens:

The morning and evening scratch feed may consist of the following, which is fed in deep litter or straw in the scratch pen:

Corn.....	2 parts.
Wheat.....	2 "
Oats.....	2 "

Nutritive ratio, 1 : 7.6.

The dry mash consists of the following:

Wheat bran.....	2 parts.
Wheat shorts.....	2 "
Meat scrap.....	1 part.

The mash should be fed from a mash hopper and kept before them at all times.

On the farm, clabber milk or buttermilk may be kept before them at all times, and will take the place of the meat scrap in the dry mash, thus lessening the cost of feeding.

One hundred hens will take about 8 quarts of grain per day—that is, 4 quarts morning and evening.

Breeding hens, turkeys, ducks, and geese should not be too fat, as the young from such birds are not so vigorous nor the eggs so fertile as those from females in medium flesh.

Certain feeds have an undesirable effect on the flavor of the flesh of the fowl consuming it, and also upon the flavor of the egg. Some of these feeds imparting objectionable odors and flavors are fish scrap, turnips, onions, and garlic.

Fat extracted peanut meal and soybean meal are high in protein content and will take the place of gluten meal in the mash.

The Influence of Artificial Light on Egg Production.—Equalization of feed distributed over the twenty-four hours is a great factor in high egg production. Thus the artificial light early and late allows the hen to eat extra meals and fill up in the late evening and again in the early morning. If the lights are used too late and too early the force feeding may be carried to the point of causing a physical breakdown or physical exhaustion and death of the bird.

Different kinds of artificial lights have been used, such as lanterns, gas, and electricity. Many employ electric lights. Snap switch electric lights may be used, and this connected with a clock so that the lights gradually go on or off as desired without an attendant.

It has been found that when the hours of light are increased, either naturally by longer days or by artificial light, there is an increased consumption of feed and more eggs produced in proportion to the feed consumed. It has been found that there is a correlation between the number of eggs produced and the number of hours sunshine. Electric lights have also been used in giving longer days to fattening and to growing chickens with the result that there were greater gains in a given period. One 40-watt lamp is sufficient in a pen 20 feet by 20 feet.

Artificial illumination should not be used on the breeders in the fall of the year. A breeding hen should not be tired out before laying the hatching eggs. Such hens should be allowed to "hibernate" during cold weather and come into full laying during the hatching season.

Amount of Feed Consumed.—Small breeds such as Leghorns and Campines will consume on an average about 65 to 70 pounds of feed per hen per year. Large breeds as the Plymouth Rocks and Orpingtons will consume an average of about 85 pounds feed per hen per year.

Palatability.—In tests run by Payne it was determined that the most palatable dry mash consisted of cornmeal, ground oats, and beef scrap. This also proved the most economical in all his tests.

Ground alfalfa and linseed meal are not so palatable and detract from the palatability of the mash, while gluten feed adds to palatability. Cotton-seed meal is at first very palatable, but if an excess be eaten the birds will become sick of it and may refuse it. Hens consume mash as a filler so that when the grain ration is increased the mash consumed will decrease.

Kempster's work on palatability places grains and other feeds in the following order of palatableness as shown by his practical feeding tests of single feedstuffs: wheat, kaffir corn, corn, cornmeal, wheat middlings, oats, sunflower seed, beef scrap, grit, oyster shell, bran. The nutritive ration of a ration in the self-selected feeds tends to become wider as the hen passes from a laying to a non-laying period.

Yolk Pigment.—The natural pigment characterizing the egg yolk, body fat, and blood serum of the hen is physiologically

identical with the xanthophyll pigment of plants. Feeding tests with laying hens in which the pigment of the feed was carotin to the relative exclusion of xanthophyll were without appreciable influence upon the amount of pigment carried by the blood serum and deposited in the yolk. The feeding of rations relatively free from both carotin and xanthophyll to laying hens resulted in a marked reduction of the amount of this pigment carried by the blood serum and deposited in the egg yolk.

The experiments reported find practical application in the control of the color of the flesh (body fat) of fattening poultry, and the control of the amount of natural pigment deposited in the egg yolk.

Milk being devoid of xanthophyll will make a white flesh in the fattening fowl or broiler.

Yellow corn containing much xanthophyll will make rich yellow yolks. The analysis of three feeds is as follows:

Feed	Xanthophyll		Carotin	
	Units yellow	Units red	Units yellow	Units red
Bran, middling, beef scrap mash.....	33.0	0.8	9.0	0.9
Yellow corn.....	60.8	3.8	54.0	1.5
Carrots.....	36.0	1.0	46.8	6.5

Yolks of eggs contain both yellow and red, the yellow greatly predominating.

CHICK FEEDING

In chick feeding, it may be said that in raising pullets for laying and breeding purposes it is well to hatch the heavy breeds, as the Orpingtons, Rocks, and Wyandottes, by the first of February, as it takes six to eight months for them to develop to maturity, while the smaller breeds will reach maturity about two months earlier.

The following ration is excellent in chick feeding.

The baby chicks are not fed for three days after they are hatched, to allow of the absorption of the yolk-sac, and are then fed the following for five days:

Rolled oats	8 parts.
Bread crumbs	8 "
Sifted beef scrap	2 "
Bone meal	1 part.

Nutritive ratio, 1 : 3.3.

This mixture is mixed with sour milk and is fed five times a day. The baby chicks must not be allowed to become chilled. If they are allowed to get out from under the hover in a corner till they begin to peep, you may know that they are cold, and the next thing that will happen is diarrhea and dead chicks.

From the fifth to the fifteenth day the following mixture may be given:

Cracked wheat	3 parts.
Cracked corn (fine)	2 "
Pin-head oatmeal	1 part.

Nutritive ratio, 1 : 7.4.

This feed is to be scattered in a litter morning and evening.

The following mixture is to be given, mixed with sour milk, three times a day, in addition to the above. At the end of fifteen days it is fed only twice a day:

Wheat bran	3 parts.
Cornmeal	3 "
Wheat middlings	3 "
Beef scrap	3 "
Bone meal	1 part.

Nutritive ratio, 1 : 2.4.

After the chicks are thirty days old give moist mash once a day, and also keep same mash in dry mash hoppers before them at all times. Give the following in litter morning and evening.

Whole wheat	3 parts.
Cracked corn	2 "
Hulled oats	1 part.

Nutritive ratio, 1 : 7.6.

After the chicks are six weeks old continue the dry mash as above, and give whole wheat and cracked corn, equal parts, in hopper. Small-sized grit and charcoal must be kept before them at all times.

Chicks should be provided with green pasture, made by spading up their run and sowing it down in oats or rape, and the chicks kept off of it till the young forage is about 1 to 2 inches high. Do not turn them on the pasture till it is dry, as dew or rain makes the grass dangerous.

Birds drink much water, and clean water must be kept before them at all times. The pans must be thoroughly washed each day, and if infection is among the chicks, must be disinfected once to twice a day with a 5 per cent. carbolic acid solution. Avoid foul, damp ground, and if brooding is done with the hen, keep her confined till the chicks are weaned. While brooding the hens' quarters should be moved to clean fresh ground once a week. The brooder coop must be thoroughly disinfected occasionally. The hen and chicks must be kept free from lice and other vermin.

In chick raising the males, and, at times, both males and females, are disposed of as broilers. Broiler feeding may be divided into three periods, as follows—growing, forcing, and fattening.

The length of the growing period is about four weeks.

There is some difference between the early maturing and the slower-growing kind.

The chick ration, as outlined above, may be given for the first period or four weeks.

The second period the ration differs from the growing ration in that it contains more protein. The protein content may be raised by adding cottage cheese to the ration or by increasing the meat scrap.

Cracked corn (coarse parts), cracked wheat, and hulled oats, equal parts, should be kept before them in hoppers at all times. In addition to this the following dry mash should be kept before them in the dry mash hopper:

Wheat bran.....	4 parts.
Wheat shorts.....	4 “
Cornmeal.....	2 “
Meat scrap.....	3 “
Charcoal.....	1 part.

Nutritive ratio 1 : 2.5.

Clabber milk or buttermilk should be kept before them at all times.

With this narrow or high-protein content ration it is necessary to keep close watch on the birds, as digestive disorders may occur. If this occurs it may be necessary to remove some of the birds and give them less meat-scrap and milk, or even to cut down on the entire flock.

This second period is variable as to length of time, owing to the fact that some breeds develop faster than others.

The fattening ration may contain much milk. In milk fattening of broilers the milk constitutes two-thirds of the ration by weight; the other one-third consists of ground grain. This makes the ration the consistency of batter. This is fed in troughs three times a day and given just what they will clean up. The ground grain may consist of the following:

Ground corn.....	10 pounds.
Ground oats.....	10 "
Ground barley.....	10 "
Beef scrap.....	10 "

Nutritive ratio, 1 : 3.1.

The grain ration may consist of the following:

Cracked corn.....	10 pounds.
Wheat.....	5 "
Oats.....	5 "

Nutritive ratio, 1 : 7.2.

The rapid growth and development that take place in the bones make a greater demand for mineral matter than this ration supplies, hence the bones break easily, unless the ration contains a sufficient amount of mineral matter, and particularly calcium.

The following mixtures have also proven excellent rations for chicks from hatching to range size which is about eight weeks of age. It should be fed five times a day, just what they will eat up clean. Better results are obtained when mixed with milk and the birds are given milk to drink.

Peanut meal.....	33 parts.
Ground corn.....	67 "
	<hr/>
	100 "

Soybean meal.....	33	“
Corn meal.	67	“
	<hr/>	
	100	“
Wheat middlings...	28	“
Corn meal.	28	“
Ground oats.....	28	“
Meat scrap.....	16	“
	<hr/>	
	100	“

Milk-fed chickens undergo heavy shrinkage when shipped alive. The most profitable way is to dress them on the plant and ship dressed for market.

The fattening period lasts from ten to fourteen days.

Pullets raised for egg production or for breeding purposes should not be force-fed.

Pullets and cockerels must be kept in separate yards after they reach a weight of about 2 pounds.

In crate feeding as many birds are placed in the crate as can find room to eat feed from the trough placed along the side. The feed is fed sparingly at first, gradually increased. The birds are fed every twelve hours, that is, morning and evening.

In feeding for eggs, fattening birds, or growing stock it is essential that the feeding be regular and done each time on the minute. Equalization of the time of feeding is essential for the best results.

Chick Feeding.—Keep clean pure water and fresh sour milk before the chicks at all times. At first dip the bills of a few of the baby chicks into the milk and they will teach the balance to drink. If the milk gets into the eyes it may ferment there and cause sores. In this case wipe out the eye with clean absorbent cotton and drop one drop of a 1 per cent. solution of Sulphate of Zinc in the eye.

The dishes must be washed clean each day and kept clean and sweet smelling.

Do not allow chicks or ducklings to have musty grain or mash. Musty feed can be detected by its odor. Do not allow them to have feed that has become putrid. Feeding trays should be cleaned in one hour after the chicks are fed and the cleanings thrown where the chicks cannot get at it.

Fermenting putrid feed may cause diarrhea and loss of chicks in forty-eight hours, and those that are affected and do not die do not properly develop. Do not give frozen feed.

The milk may be either fresh sweet milk or sour milk (clabber) or buttermilk. Do not feed sour milk at one time and sweet milk at another, as this method may result in serious bowel trouble.

Charcoal to the baby chick aids digestion, prevents sour crop and bowel disorders. Feed chick size grit, charcoal, and shell in self-feeding hoppers.

Clover, blue grass, rape, vetch, sprouted oats, lettuce, and alfalfa 4 to 6 inches high and this cut fine with a knife makes excellent green feed for the baby chick and should be fed not later than the sixth day.

Dry Litter Feeding of Chicks.—Deep litter feeding of chicks after one week of age has been recommended. The first step is to clean and disinfect in a thorough manner the interior feed pen. Then place upon the floor about 2 or 3 inches of short cut straw or chaff and sprinkle upon this about 15 pounds of scratch feed, then another layer of about 2 inches of litter and more scratch feed. Repeat these layers till there has been sown down about 60 pounds to each 50 chicks, which is about what they will consume in about six weeks.

TURKEYS AND POULTS

In turkey raising an orchard will be found an excellent range.

Cottage-cheese, buttermilk, or clabber milk is excellent. The breeders need green feed, but usually secure this by foraging. Bone meal, also meat scraps from the table, may be fed.

The birds need plenty of grit. Oats and wheat make excellent grain feeds, and should be scattered over the ground and not fed from troughs.

Examine the turkey hens and poults to make sure they are not infested with lice or other vermin. In case they are infested dust with louse powder, as in the case of hens.

The young poults should not be fed for the first day after hatching, for the same reason that feed is withheld from the baby chicks. At the end of twenty-four hours feed hard-

boiled eggs with dried bread crumbs. After the fourth day this may be replaced with hulled oats, cracked corn, and cracked wheat. Fine grit and charcoal should be kept before them at all times. The young poult must not be allowed to wander over the farm till it has grown large enough to be strong and out of danger of the ills the baby poult is heir to. This will require about five to six weeks. It is a good plan to confine the hen turkey, as is the case of the hen with baby chicks.

Poults must not be allowed to run in the dewy grass, or be out in a rainstorm. They must be protected from excessive heat by being provided with shade.

If the turkeys begin to "hang around" the buildings it is an indication that they are not securing enough feed on the range. It is then necessary to feed them. This feed may consist of a grain ration, consisting of corn, wheat, and oats, equal parts.

When it is desired to prepare them for market it is advisable to place them in yards, so as to limit their exercise. Gradually bring them up to full feed. Besides grain, such as corn, wheat, and oats, they should have all the milk they will drink, and they should be fed twice a day and given all they will clean up as soon as on full feed.

DUCKS AND GEESE

During the laying season ducks should be confined in the house till about 9 o'clock in the morning. By this time most of the eggs will be laid. Ducks have a tendency to lay their eggs in the yard.

On Long Island, in 1914, there was 1,165,000 ducks hatched. Mr. Hallock, one of the largest and most successful breeders on the island, told the writer that his ration for old breeding ducks was as follows:

Wheat bran.....	10 parts.
Cornmeal.....	10 "
No. 2 flour.....	1 part.
Ground alfalfa.....	2 parts.

Nutritive ratio, 1 : 5.9.

Mixed and fed as mash, using water in mixing.

His feed for ducklings consists of the following:

Cornmeal	2 parts.
Wheat bran	2 "
Beef scrap	1 part.
No. 2 flour	1 "
Green stuff	1 "

Nutritive ratio, 1 : 3.4.

The green feed consists of cut grass or sprouted oats. The mash is always fed wet. They are given all they will "clean up," and are fed four times a day.

Another well-established way of handling the young ducklings is as follows: The ducklings should not be fed for the first day. After the first day, and for the succeeding seven days, the feed should consist of wheat bran, cornmeal, wheat middlings, of each equal parts. Grit must be furnished to young and old alike. The mash should be mixed with sour milk or buttermilk.

There should be added to the mash after the third day about 5 per cent. meat scrap and the same amount chopped sprouted oats.

After the seventh day this feed may be replaced with the following ration:

Wheat bran	10 pounds.
Wheat middlings	5 "
Cornmeal	3 "
Meat or fish scrap	2 "

Nutritive ratio, 1 : 3.4.

Green feed and grit must be given.

When eight weeks old the ducks are given their fattening ration, which consists of the following:

Wheat bran	10 parts.
Wheat middlings	10 "
Cornmeal	10 "
Beef scrap	1 part.

Green food and grit is also supplied.

The fattening period lasts about three weeks.

The goslings and ducklings must be protected from the sun.

They should be fed from troughs; the troughs should be kept clean and sanitary.

The goslings must be provided with an abundance of clean, fresh water.

On some North Carolina farms geese are used to keep grass out of the cotton patch. It is estimated that ten geese are equal to one hoeman. The old stock is fed a mixture of corn, wheat, and oats, equal parts, in the morning.

The goslings are allowed to run in the field and are given additional feed consisting of cornmeal and water.

In handling geese in the fall they are sometimes moved to fields from which crops have been harvested or turned on fields of Swedish turnips or rape much as hogs are at times handled. They thrive on this forage. The shelter consists of low made portable sheds which are, if possible, placed under hedge or other shrubbery and which may be moved from place to place. Hard floors made of brick or cement are unsuitable for geese. By this method of handling, the quality of the ground is improved by the manure dropped on it by the geese.

It requires four or five weeks to finish the birds for market. During the finishing period the geese are confined in large sheds provided with plenty of fresh air and light. About 25 are kept in each feed lot. When ready to sell or slaughter all should be disposed of at one time. When part of the geese are removed the balance fret and do not, after that time, make satisfactory gains.

The fattening birds receive two meals a day. Barley meal and middlings are sometimes used. These are mixed in equal proportions and made crumbly moist with water or preferably skim milk or buttermilk. The protein in the milk aids in the fattening processes and improves the flavor of the flesh. Another ration consists of equal parts cornmeal, middlings, and barley meal. Bean and pea meal are said to produce a hard flesh. Brewers' grain and mashed cooked potatoes mixed with the mash have given good results. The mash is usually given in the morning and a grain feed in the evening. The evening feed may consist of corn, oats, wheat, and barley. Good results are obtained by soaking the grain in warm water

for a few hours before feeding it. Clean fresh water should be placed before them three times a day.

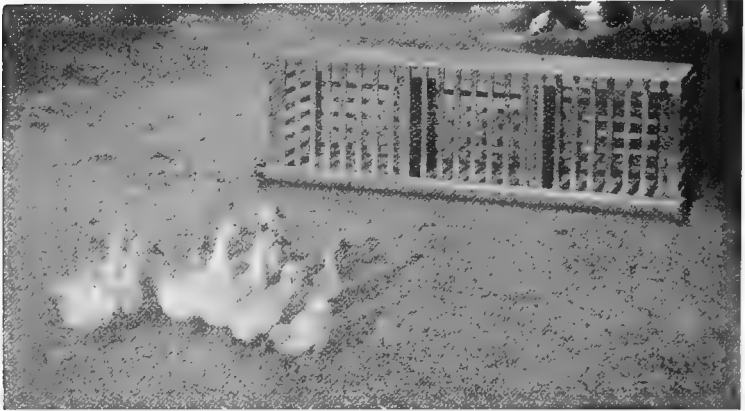

FIG. 108.—Some young ducks, and in the background is a three-compartment fattening crate. These crates are so constructed that the lid for the removal of the birds is at the top.

The greatest demand for geese is usually at Thanksgiving and Christmas.



FIG. 109.—A tramway to carry feed on a commercial duck plant.

The house for geese should possess 10 square feet floor space per bird.

Young geese begin to lay about the middle or end of February and old ones a month later. Hens may be used for hatching geese eggs and when so used each hen is given 4 goose eggs. The young goslings must be protected from the hot sun as this is fatal to them.

Geese are great grass eaters and require pasturage.



FIG. 110.—Duck nursery, commercial plant.

Ducklings are subject to cramps where the quarters are too damp, or if the birds are exposed to drafts. Their roosting quarters should be well bedded down with straw. In adult ducks 2 square feet are allowed for roosting space.

The duck houses should not be too close to the water as they may become too wet, and cramps in the breeding stock

result. The house should be on a high dry ground and the ground slope from the building. The floor must be dry.

Young ducks are usually dressed and marketed at about eleven weeks old, and should weigh about 6 pounds and average about 16 cents per pound.

Pekin ducks are most used. They have weight and meet the market demands.

There are two ways of making money with ducks. These are by the production of soft roasters and eggs.



FIG. 111.—Duck-breeding quarters.

The Pekin duck is used on all large duck farms for soft roasters, while the Indian Runners are the most popular for market eggs. The young can be hatched with hens, although an incubator is to be preferred where large numbers are reared. Ducks' eggs require more moisture than do hens' eggs. It does not pay to set eggs under a duck because, with proper care, she will continue to lay many more eggs than if allowed to hatch and rear young. Incubator-hatched ducks require a brooder. Any good brooder for chicks will work well with

ducks, although they require cleaning oftener than they do with the chicks.

It is a mistaken idea that ducks require a pond or creek in which to swim, although this is good for the breeders. The only water the young should have is plenty to drink. They will grow much faster than if they are allowed to swim. There is also danger of their being caught by turtles, minks, etc. The breeders should be kept in a yard or pen until 9 or 10 o'clock each morning, or until they have laid, or they are likely to lay their eggs in the water and lose or break them. Both



FIG. 112.—Geese in a pond. Geese should have water. Note goose house in the background.

old and young ducks need plenty of shade. If there is no tree shade to be had, it is a good plan to cover some frames with burlap or to build sheds for them. They do not need as warm buildings as do hens, but their houses require more ventilation. Dirt or sand floors are preferable, and they need plenty of bedding. This should consist of shavings, sawdust, or straw. The litter should be removed often or more clean litter put on top to keep the floor dry.

As ducks naturally eat large quantities of meat in the form of worms they should be furnished plenty of meat scraps.

A good ration for growing young ducks is equal parts of cornmeal, wheat middlings, wheat bran, meat scrap, and chopped vegetables, unless they can obtain green grass. This feed should be fed crumbly or slightly moistened, and can be kept before them all the time for the first few days, while for the next two or three weeks they may be fed four times a day.

Where skimmed milk is obtainable it may be used to moisten the feed. In this case only one-half of the amount of meat scrap would be necessary. Be sure and see that they have water before they commence to eat. Never allow feed to sour. Sour feed is likely to kill the young ducks and is dangerous for old ones. The water should be deep enough in the dishes so that they can run their beaks in full length to clean the feed

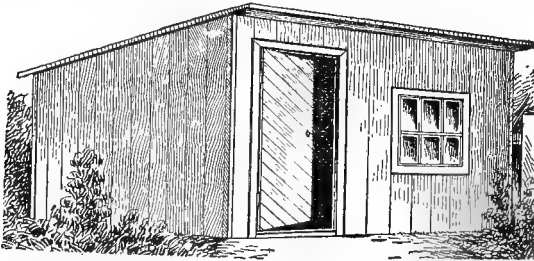

FIG. 113.—A cheap and convenient duck house. The floor is dirt and level, and covered 6 inches deep with clean straw on which the ducks roost.

out of their nostrils, or they may become clogged with the mash and make breathing difficult.

The breeding ducks may be allowed to run to water part of the day, and should be fed morning and night. The mash may consist of 15 parts cornmeal, 10 parts wheat middlings, 10 parts wheat bran, 10 parts meat scrap, 10 parts alfalfa meal or chopped green feed, and, during the laying season, corn at noon. Grit and shell should always be kept before them. The ducks are usually sold as soft roasters when about ten weeks of age, as they do not gain much in weight after that time and they eat a large amount of feed. This will soon prevent any profit. Save the feathers—they bring a good price. You can expect to obtain about 1 pound of feathers

from a dozen young ducks when killed for market. After the tenth or eleventh week they begin to develop many large pinfeathers, which make dressing more laborious.

In housing ducks there should be 2 square feet of floor space for each duck. Clean straw should be provided, which should cover the entire floor to a depth of 6 or 7 inches.

Ducks make their nests on the floor by burrowing into the straw.

The floor must be dry. The roof need not be high. There must be plenty of fresh air, but no drafts.

A fence 18 inches to 2 feet high with 2-inch mesh will hold the ducks in the yard.

Do not frighten ducks by moving them by aid of a lantern at night. Laying ducks under these conditions may partially cease to lay.

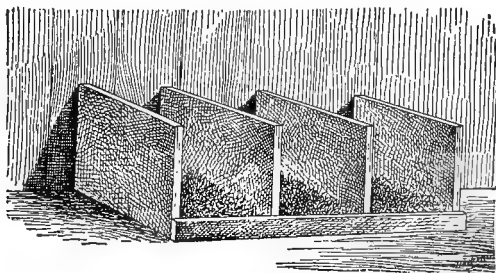

FIG. 114.—Convenient nests for the duck house. These are made on the floor.

Breeding geese may be fed chopped turnips, mangles, fed in mash with cornmeal, wheat bran, and ground oats, the grain being used in equal parts. The mash is always fed wet.

Geese must also be provided with grit and an abundance of fresh water.

Breeding geese must not be allowed to become too fat.

In white geese it is somewhat difficult to differentiate the young goose from the young gander. The voice of the male is more shrill and fine and he is usually larger in body. The female usually has a harsh, coarse voice.

The goslings need careful attention during the first week.

Like the adult, they must be fed only a mash, which usually consists of cornmeal, 10 pounds; meat scrap, 1 pound, mixed with clabber milk or buttermilk, or the following ration may be given.

Low grade flour.....	10 pounds.
Cornmeal.....	10 "
Oatmeal.....	10 "
Barley meal.....	10 "

Nutritive ratio, 1 : 7.9.

This is to be mixed and fed wet.

The Development of the Different Parts of the Chick.—
The relative weights of the ovary and oviduct of Single Comb

THE DEVELOPMENT OF THE MUSCULAR SYSTEM

(Per cent. of live weight)

	1st m.	2d m.	3d m.	4th m.	5th m.	6th m.	9th m.
Female.....	38.0	37.0	42.0	45.0	46.0	48.0	46.0
Male.....	37.0	44.0	46.0	45.0	47.0	46.0	48.0

SKIN AND APPENDAGES

Female.....	12.0	14.0	16.0	18.0	17.0	16.0	15.0
Male.....	12.0	14.0	16.0	17.0	16.0	20.0	19.0

SKELETON DRY

Female.....	3.0	3.0	5.0	6.0	7.0	6.5	5.0
Male.....	3.0	4.0	5.0	6.5	7.0	6.5	7.0

DIGESTIVE SYSTEM

Female.....	14.0	13.0	9.0	9.0	9.0	7.5	8.0
Male.....	13.0	12.0	9.0	8.0	8.0	6.5	6.0

REPRODUCTIVE SYSTEM

Female.....	0.04	0.03	0.03	0.07	0.27	6.15
Male.....	0.07	0.04	0.20	0.46	0.47	0.58

White Leghorns to total body weight are as follows: at 1 month, 0.04 per cent.; 2 months, 0.03 per cent.; 3 months, 0.03 per cent.; 4 months, 0.08 per cent.; 5 months, 0.07 per cent.; 6 months, 0.27 per cent.; 6 months, 3 weeks, 5.75 per cent., at which time the ovary and oviduct were becoming active; 9 months, 6.15 per cent.; now active.

In Leghorns length and height is fully developed in 28 weeks, in both males and females. In 20 weeks the framework is fully developed, and the weight at about 28 weeks. The following is the rate of growth in weight. The increase in weight in the first 4 weeks is 190 per cent.; 8 weeks, 178 per cent.; 12 weeks, 98 per cent.; 16 weeks, 62 per cent.; 20 weeks, 30 per cent.; 24 weeks, 20 per cent.; 28 weeks, 16 per cent.; 32 weeks, 10 per cent.; 36 weeks, 4 per cent.

GUINEAS

Young and old guineas are fed similar to chickens.

PIGEONS

The young pigeon is fed from both the male and female parent for a period of about one week with a cheesy material regurgitated from their crops; then partially digested grain, in like manner. The entire feeding by the parent is about three weeks.

The following is an excellent pigeon ration:

Whole wheat.....	10 parts.
Cracked corn.....	10 "
Small peas.....	5 "
Kaffir corn.....	5 "
Russian hemp-seed.....	5 "

Nutritive ratio, 1 : 7.0.

This should be fed three times daily from troughs. One pint is sufficient for 6 birds.

The feed for all birds should be sound and wholesome. Smutty, moldy, rotten grain injures birds by causing digestive derangements and often death.

Pigeons are most valuable as squab producers from 2 to 6 years old. The small varieties mate and breed at 5 to 6 months old. Squabs hatched in April, May, and June, when their value on the market is low, make good breeders.

If a breeding pigeon dies its mate should be removed from the pen and a new mate provided.

For further information on feeding of pigeons see Chapter IV.

Pigeons are allowed 4 square feet of floor space per pair. It is essential that the house be dry and that the food and water be of good quality.

For strictly squab raising the Homers perhaps prove the most prolific, and hence most profitable. Other breeds used for this purpose are the White King, Runt, Maltese Hen, and Carneaux. The average weight should be 8 or 9 pounds per dozen.

A HOME-MADE FEEDER AND EXERCISER

The illustration (Fig. 115) shows a home-made feeder and exerciser that can be raised or lowered as needed to fit the size chickens it is to be used for.

Any tinsmith can make one, large or small, as desired. It should be made of galvanized iron and will last indefinitely. The barrel must be round and shaped like a bottle. *A* represents a wire on which is hooked a spring (*D*), the same as used to hold up a canary bird cage; *B* represents a round tin case, so that the corn cannot choke the spring and stop it from working; *C* is the support to keep the case in its place; *E* is a piece of tin, shaped like a funnel, and hooked to spring *H*, and should be of the same material as sieves are made, while *G* is wire-wrapped around to keep it in place so that it will hold corn, which is seen by the birds, who pick at it, thus releasing the funnel from the barrel-neck which lets out the corn. The spring brings back the funnel to the barrel-neck again, thus stopping the corn till the birds pick again.

OTHER RATIONS

The following rations for chick feeding are recommended by the various experiment stations. Missouri Experiment Station:

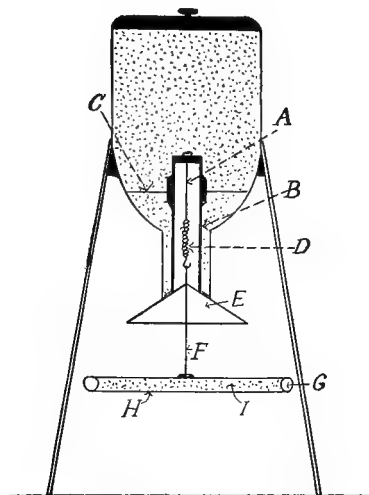

FIG. 115.—A home-made exerciser and feeder. (See description in text.)

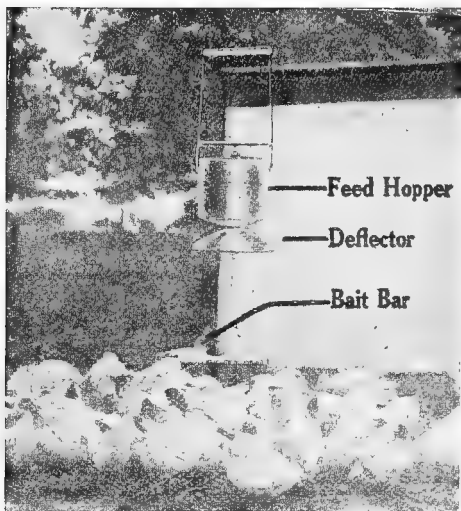

FIG. 116.—An exerciser sold on the market. The birds picking at the bait in the small cylinder close to the ground cause some grains of feed to drop out onto the deflector and to the ground.

“Feed for the first forty-eight hours:

Rolled oats.....	2 parts.
Wheat bran.....	1 part.
Small amount of charcoal.	

Nutritive ratio, 1 : 5.1.

“Give clean, sharp sand after the first feed, but not before. If clean sand cannot be secured, use fine commercial chick grit. Water and also sour milk or cottage cheese should be placed before the chicks at the time of the first feeding.

“When four or five days old give the following ration:

Wheat bran.....	2 parts.
Wheat shorts.....	1 part.
Cornmeal.....	1 “
Rolled oats.....	½ “

Nutritive ratio, 1 : 5.1.

“To the above dry mash add ½ pound fine salt to each 100 pounds of mash.

“From the above ration work gradually into the use of cracked corn, wheat, and kaffir corn, after the chicks are six weeks old.”

The Iowa State Experiment Station recommends the following rations in chick feeding:

RATION I

Cracked grain

“First four weeks:

Cracked wheat.....	3 parts.
Finely cracked corn.....	2 “
Pin-head oatmeal.....	1 part.
Feed twice daily.	

Nutritive ratio, 1 : 7.4.

“For later feeding give the following:

Whole wheat.....	3 parts.
Coarsely cracked corn.....	2 “
Hulled oats.....	1 part.

Nutritive ratio, 1 : 7.4.

Ground feed

“First four weeks:

Wheat bran.....	7 parts.
Alfalfa meal.....	2 “
Cornmeal.....	3 “
Wheat middlings.....	3 “
Sifted beef scrap.....	4 “
Ground bone.....	1 part.

Nutritive ratio, 1 : 2.4.

“For later feeding give the following:

Wheat bran.....	3 parts.
Alfalfa meal.....	3 “
Cornmeal.....	3 “
Wheat middlings.....	3 “
Beef scrap.....	4 “
Ground bone.....	1 part.

Nutritive ratio, 1 : 2.3.

“The ground feed is moistened with skimmed milk, and fed three times a day at the start and decreased as the chicks grow older.”

RATION II

Cracked grains

Grain ration “A” fed first eight weeks:

Cracked corn.....	2 parts.
Cracked wheat.....	1 part.
Steel cut oatmeal.....	1 “

Nutritive ratio, 1 : 7.6.

Grain ration “B” fed after eight weeks old:

Coarsely cracked corn.....	2 parts.
Wheat.....	1 part.
Oats.....	1 “

Nutritive ratio, 1 : 7.6.

Fed twice daily in litter from 1 to 6 inches deep.

Ground feed

Mash ration “C” fed first two weeks:

Stale bread.....	3 parts.
Oatmeal.....	3 “
Eggs (tested from incubator).....	4 “
Bran.....	1½ “
Cornmeal.....	1½ “
Ground bone.....	1 part.

Nutritive ratio, 1 : 3.7.

Mash ration "D" fed after the second week:

Cornmeal.....	3 parts.
Wheat middlings or high-grade shorts.....	2 "
Wheat bran.....	1 part.
Beef scrap.....	1 "
Ground oats.....	1 "
Ground bone.....	1/2 "
Salt.....	1/10 "

Nutritive ratio, 1 : 3.6.

Ground feed made moist with sour milk.

Wheeler gives the following table as feed requirements of chickens per day (twenty-four hours) for each 100 pounds of live weight.

Birds	Digestible nutrients (pounds)			Ash	Nutritive ratio
	Pro- tein	Fat	Car- bohy- drates		
<i>Growing chicks:</i>					
First two weeks.....	2.0	0.4	7.2	0.5	1:4.1
Two to four weeks.....	2.2	0.5	6.2	0.7	1:3.4
Four to six weeks.....	2.0	0.4	5.6	0.6	1:3.3
Six to eight weeks.....	1.6	0.4	4.9	0.5	1:3.7
Eight to ten weeks.....	1.2	0.3	4.4	0.5	1:4.3
Ten to twelve weeks.....	1.0	0.3	3.7	0.4	1:4.4
<i>Adult (maintenance only):</i>					
Capon, 9 to 12 pounds....	0.3	0.2	1.7	0.06	1:7.5
Hen, 5 to 7 pounds.....	0.4	0.2	2.0	0.1	1:6.2
Hen, 3 to 5 pounds.....	0.5	0.3	2.9	0.15	1:7.4
<i>Egg production:</i>					
Hen, 5 to 8 pounds.....	0.65	0.2	2.25	0.2	1:4.2
Hen, 3 to 5 pounds.....	1.0	0.35	3.75	0.3	1:4.6
Total digestible nutrients					
<i>For ducklings:</i>					
First two weeks.....	4.0		18.35		1:3.6
Two to four weeks.....	4.1		17.12		1:3.2
Four to six weeks.....	2.7		11.28		1:3.2
Six to eight weeks.....	1.7		8.02		1:3.7
Eight to ten weeks.....	1.4		7.00		1:4.0
Ten to twelve weeks.....	0.9		4.55		1:4.1

FINISHING BIRDS

Finishing birds for market may be divided into two methods: first, fattening; and, second, fleshing.

In fattening birds the ration has a medium or wide nutritive ratio. The increase in weight is due to the storing of fat in the abdominal cavity and other parts of the carcass. This method is most used in finishing hens for the market.

In fleshing birds the nutritive ratio of the ration is narrow. This method is used in finishing broilers for market. This kind of ration promotes growth, lays on fat which is more likely to be distributed among the muscles of the carcass, and makes the bird plump for market.

In discussing the finishing or fattening of birds the Pennsylvania Experiment Station says: "One of the handicaps in the marketing of farm-raised poultry is that they are usually of mixed breeding. These mongrel chickens vary in size and shape of body and in color of the skin. They do not make an attractive appearance when they are dressed, as they are too uneven in size, shape, and color.

"A good market bird is one that has a good shaped body, good health, and the ability to stand forced feeding in close confinement. The body of the bird should be long, deep, and wide.

"The feed that is generally used in feeding consists of white bolted cornmeal, low-grade flour, oat flour, and fine ground hulled oats and wheat middlings. Buckwheat middlings are good for fattening, but it is difficult to secure them in some sections of the country.

"A very satisfactory ration is as follows:

Bolted cornmeal.....	24 pounds.
Low-grade flour.....	6 "
Wheat middlings.....	1 pound.
Buckwheat middlings.....	1 "
Peameal.....	1 "
Oatmeal.....	1 "

Nutritive ratio, 1 : 5.5.

"Some feeders add tallow to their ration. Better flavored poultry can be secured by not feeding tallow. The ground

feeds are thoroughly mixed together and then moistened with buttermilk. About 2 pounds of buttermilk should be added to each pound of dry feed. This will make the mixture of such consistency that it will pour out of the bucket. The birds should be starved about twenty-four hours before beginning the feeding process. This is to get the birds emptied out before starting on a new feed. At first give only about half what they will clean up, and gradually bring them up to full feed. Poultry feeders usually secure a gain of 25 to 35 per cent. in two weeks."

The New Jersey Experiment Station recommends the following ration as a broiler ration:

MIXTURE No. 1

Skim Milk Mash

Ground oats.....	25 pounds.
Cornmeal.....	25 "
Wheat middlings.....	25 "
Beef scrap.....	15 "
Granulated bone.....	10 "
Total.....	100 pounds.

Nutritive ratio, 1 : 3.0.

"Moisten with sour milk and feed in trough. Be sure the troughs are kept clean and that mash is not mixed too wet or sloppy."

The following ration is given by the same station to finish roasting chickens for market:

Fleshing Mash

Cornmeal.....	40 pounds.
Wheat middlings.....	20 "
Ground oats.....	20 "
Beef scrap.....	20 "
Total.....	100 pounds.

Nutritive ratio, 1 : 3.4.

Concentrated buttermilk can be bought on the market. It usually sells for five cents a gallon, and when diluted each gallon makes 3 gallons. It is made as follows:

A large tank is used in which a steam-pipe is run to heat the

buttermilk as soon as it comes from the churn. This causes the whey to come to the top and an outlet, two-thirds from the top of the tank, lets two-thirds of the water out. This gives a concentrated buttermilk. Care is used to not get it too warm, as the concentrated buttermilk will have a rubber appearance and the whey will be hard to digest.

One gallon of concentrated buttermilk represents the solids of 3 gallons of churned buttermilk, so that when ready to use 2 gallons of water is added to 1 gallon of the concentrated product; this will give an equivalent to 3 gallons of churned buttermilk.

Another excellent fattening ration for adult hens consists of the following:

Cornmeal.....	24 pounds.
Wheat middlings.....	6 "
Ground oats.....	4 "

Nutritive ratio, 1 : 8.0.

In fattening or finishing work with mature hens the Plymouth Rock, Wyandottes, and Rhode Island Reds can be fattened or finished at less cost per pound gain than the Mediterranean breeds, as the Leghorns.

Individual birds of the same breed vary in the amount of fat or gain in weight made.

Many are having excellent results in finishing old hens and cock birds with a ration consisting of equal parts ground corn and red dog flour, mixed with enough buttermilk to make the consistency of batter.

It is said by some investigators that wheat flour is more economical than oatmeal.

The following is a good fleshing ration:

Ground corn.....	75 pounds.
Distillers' grain.....	25 "
Total.....	100 pounds.
Buttermilk.....	150 "

The birds are given what they will clean up in twenty minutes and are fed three times a day.

The distiller's grain furnishes the essential fundamental nitrogen complexes required to obtain the greatest amount of gain from the ration in the shortest space of time.

Table showing the age in weeks and tenths of weeks at which chickens of the breeds named reached the weights indicated in pounds at the top of each column, and average weight for the period of growth observed.

	1 lb.	2 lb.	3 lb.	4 lb.	5 lb.	6 lb.	7 lb.	8 lb.	9 lb.	Av. wt.	Av. wks.
<i>Males:</i>											
W. Rock.....	6.7	9.6	12.25	14.7	17.2	20.1	21.3	26.3	7.73	28.0
W. Wydt.....	7.3	11.6	14.6	17.3	22.1	24.0	5.43	24.7
R. I. Red.....	7.8	11.6	14.7	18.5	23.0	24.5	5.4	25.8
Bf. Orp.....	7.5	11.0	14.0	16.2	18.5	21.0	23.0	24.0	27.0	7.2	25.0
W. Leg.....	8.0	11.8	16.6	22.5	4.26	28.0
<i>Females:</i>											
W. Rock.....	7.6	11.3	14.4	18.5	22.6	25.8	6.07	28.0
W. Wydt.....	7.3	12.0	15.7	20.7	25.0	5.17	26.0
R. I. Red.....	8.6	13.3	14.8	24.3	4.48	27.4
Bf. Orp.....	7.6	11.6	14.8	18.6	23.3	4.9	24.0
W. Leg.....	9.0	15.0	24.5	3.14	26.5
<i>Both Sexes:</i>											
W. Rock.....	7.15	10.5	13.3	16.6	19.9	22.9
W. Wydt.....	7.3	11.8	15.1	19.0	23.5
R. I. Red.....	8.2	12.4	16.5	21.4
Bf. Orp.....	7.55	11.3	14.4	17.4	20.9
W. Leg.....	8.5	13.4	20.5

THE CORNELL FATTENING RATION

By weight.		By measure.
100 pounds	Cornmeal.....	95 quarts.
100 "	Buckwheat middlings or ground wheat with hulls removed	90 "
100 "	Red dog flour.....	83 "
30 "	Beef scrap.....	25 "
1 pound	Charcoal.....	1½ "

These are thoroughly mixed together. About twelve hours before using mix the desired amount with skim sour milk or buttermilk (the latter preferred) to the consistency of batter. This mixture should be allowed to sour. Ten pounds of feed usually require 7 to 9 quarts of skim milk or buttermilk.

Fast for twenty-four hours before feeding the fattening ration. The ration should be fed sparingly at first. The appetite should be kept sharp by feeding only as much as will be cleaned up in fifteen to twenty minutes. If they have more feed than they can digest properly for a meal or two they are liable to "lose their appetite," and fail to grow well.

Feed fowls or mature young stock three times daily for



FIG. 117.—A good and convenient fattening crate. It consists of three compartments.



FIG. 118.—Rear view of a stall fattening crate. The stalls are 8 inches wide.

about two weeks. This is as long as they will do well under heavy feeding.

In fattening broilers feed this ration morning and night only, giving at noon a light feed of cracked corn and wheat. A supply of fresh water should be accessible at all times.

The best way to fatten poultry is to restrict exercise, by placing the fowls in well-ventilated coops, 2 feet square, having the bottom slatted or covered with $\frac{1}{2}$ -inch wire cloth. This will hold four to six fowls or eight to ten young birds.

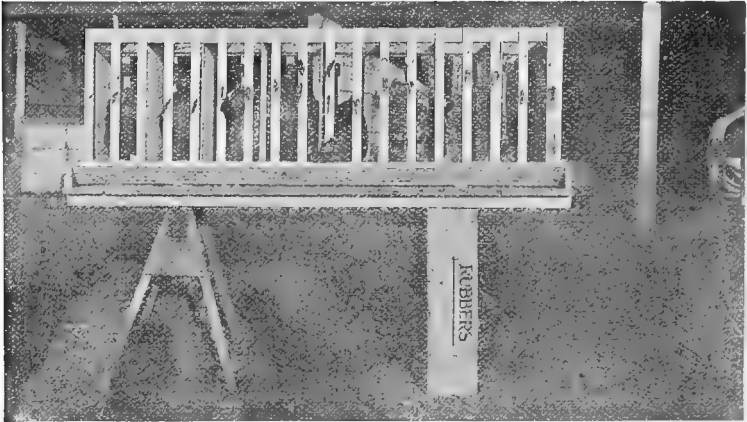

FIG. 119.—Front view of the compartment fattening crate, showing the feed trough.

The fattening coop should be located in a cool, shady place in hot weather and in a comfortable place in cold weather.

The fowls should be thoroughly dusted with lice powder, as fowls infected with lice do not fatten well. Fowls or chickens of low vitality do not fatten readily.

When stock fattened in this way is shipped to market the packages should be marked "milk fed." This will secure the best price.

In giving animal feed to chicks it has been found that meat-fed chicks make quicker and cheaper gains than others regardless of size, and that chicks started on a ration deficient in animal feed never regain their lost ground.

In the fattening of fowls, animal feed has appeared to be essential to best results except when milk has been used. Milk fed poultry are of superior quality and usually brings about five cents above the current market price. Animal feed is very important in duck feeding. Ducks do not do well on buttermilk.



FIG. 120.—A crumming machine at work.

Fat or oil is laid down in various tissues throughout the body and has a tendency to soften the flesh and make the table meat more tender and palatable. The meat is more digestible; when cooked this fat melts and has a tendency to

further soften the flesh, whereas in lean fowls the water evaporates and leaves the meat dryer and harder.

Old hens will fatten better in the spring than in late summer or fall. This is due to the fact that as the year goes on the hen has less vitality due to heavy laying, molting, and the hot weather.

Fattening Establishments.—There are many establishments for fattening poultry. Their capacity varies from 20,000 to 30,000 and even more. Most profitable fattening is with broilers weighing 1 to 2 pounds. The fattening rooms are well ventilated. The birds are fed morning and evening. The ration consists of mash with twice its quantity by weight of milk. Many establishments use the condensed buttermilk. The birds are usually fed about fourteen days. Those going off feed are slaughtered as soon as noted.

The crates are placed in tiers. The stacks are from three to five high. These crates are about the size of live poultry shipping crates, and in fact some fattening establishments use the shipping crates. The fronts are slatted so the birds can be fed from a trough located just outside the crate. Each coop has a netting bottom and is provided with four legs located at the corners. Under the crate is a metal pan to catch the droppings. These pans are cleaned each day. In many cases these crates are made movable and as fast as one lot is disposed of the crate is dipped in a boiling solution of some Standardized Coal Tar Disinfectant Dip. This thoroughly disinfects the crate and prevents spread of contagious diseases, especially the troublesome roup.

While fattening methods may be by trough, hand, funnel, and cramming machine, yet the method practised by American feeders is by trough.

In hand cramming the food is mixed into a thick paste and formed into pellets or boluses about $\frac{3}{4}$ inch long and $\frac{1}{2}$ inch thick. The operator after preparing the boluses grasps the bird and holds it firmly between his body and left arm, opens the mouth with the thumb of his left hand, dips the bolus into a vessel of whey or milk, inserts it into the mouth, passes it down the throat with his finger, and then carries the food into

the crop by running his finger and thumb down the side of the gullet.

In cramming by funnel the mash is mixed with milk making it about the consistency of batter. By aid of a proper funnel and rubber tube the crop is filled.

A room temperature of about 60° is most conducive to the fattening processes.

Sour milk is better than sweet milk because of the acid content, which is an aid to digestion. Therefore digestion takes place quicker and there is also less danger of "crop sickness" (indigestion). It also stimulates the appetite. Milk contains large amounts of phosphates, and no xanthophyll, which have a tendency to whiten the flesh. This also holds good with turkeys, ducks, and geese.

Some fatteners use tallow or other fat. This is used where the birds are cram fed by machine. A quarter ounce is given to each bird per day or one tablespoonful to each ten fowls. This is gradually increased to three or four times this amount. Usually fowls fret when first placed in coops and lose weight for the first two or three days. After this time they begin to increase in weight. It is best not to feed for the first day, giving only water, and then gradually bring them to full feed.

In preparing the birds for slaughter it is best to withhold all feed for twenty-four hours before killing, as the food remaining in the digestive tract quickly undergoes decomposition. The crop should be empty.

Poultry may be fattened in small flocks in an old shed, box-stall, or small yard with temporary coops where the exercise is restricted. If both pullets and cockerels or hen and cocks are to be fed, the males should be separated from the females. Chickens make greatest gains while young. Cockerels 150 to 175 days old make small gains.

Finished poultry shipped to market alive should be delivered to the station late in the evening, if train service permits, so that they will travel in the cool and be delivered to market the next morning. Just before shipping they should be given a full feed of grain and all the water they will consume. In this way the shrinkage will be less.

How to Ship Live Poultry.—All shipping coops should be in good condition. Otherwise they may come apart in transit, as they frequently are roughly handled.

The coops should be high enough to allow whatever kind of poultry is shipped to stand up. Low coops should not be used as suffocation may result. More birds may be placed in a coop in cold than in hot weather.

Keep different stock separate as far as possible. If sufficient to fill coops in the different kinds it is better to ship the hens, spring chickens, roosters, turkeys, ducks, and geese in separate coops.

Standard size chicken crates for shipping to market are 2 feet by 3 feet by 1 foot.

Standard turkey coops are 2 feet by 3 feet by 1 foot 4 inches.

The following is suggested as the proper number of birds to be placed in each standard coop:

	Number to a coop
Turkey—Gobblers.....	5
Hens.....	6
Geese—Large.....	6
Medium.....	8
Small.....	10
Ducks—Large.....	10
Medium.....	14
Small.....	18
Cocks and Fowl:	
7 to 10 pounds.....	8
5 to 7 pounds.....	10
4 to 5 pounds.....	14
3 to 4 pounds.....	16
2 to 3 pounds.....	18
1 to 2 pounds.....	20

CHAPTER XVIII

BROILERS AND DRESSING OF FOWL

BROILERS

ALL female birds one year or over are known on the market as fowl.

Most hens are disposed of at about their third year and in the fall, to make room for the pullets raised during the summer.

Market prices of fowl remain fairly even throughout the year, making very little fluctuation except in the case of very early broilers. As a rule, especially on the large markets, there is very little demand for fowl weighing 3 pounds or under.

A few hundred broilers should be raised every year on the farm.

A *broiler* is a young, rapidly growing chicken, which, on account of quality of flesh and size, is desired for broiling purposes.

On the market there are three types of broilers—namely, squab broiler, weighing dressed, from $\frac{3}{4}$ to $1\frac{1}{4}$ pounds; medium broiler, weighing dressed from $1\frac{1}{2}$ to 2 pounds; large broiler, weighing dressed 2 to $2\frac{1}{2}$ pounds.

The word squab in the term squab broiler comes from the name given to young pigeons, and broiler from the method of cooking.

Large framed breeds like the Asiatics that mature late are not suitable for squab broilers.

The broiler should gain 30 to 35 per cent. of its total weight in the fattening period which is usually fourteen days.

Figure 121 shows the difference between the Mediterranean breeds and the American breeds as table fowls. Both are finished products, the Leghorn hen weighing 3.25 pounds and the Partridge Plymouth Rock 6.00 pounds. The hen at the extreme right is a hen the same size and age of hen No. 2

but is unfinished. This shows the difference between the unfinished and the finished product. Both are Partridge Plymouth Rocks.

The broiler of medium type—that is, the one dressing from $1\frac{1}{2}$ to 2 pounds—is in greatest demand.

In serving broilers on the table squab broilers are most often served on toast, two halves to the person, while in the case of the medium broiler only one-half is served to each person, hence the medium broilers are the most economical.



FIG. 121.—Dry picked fowls. 1, Finished S. C. White Leghorn hen; 2, Finished Partridge Plymouth Rock hen; 3, Partridge Plymouth Rock hen, not finished. It pays to fatten hens for market.

The broiler season extends from November to July, with its greatest demand in February. As summer comes on the price becomes very low on account of the great supply at that season of the year.

The most profitable market for broilers is from December to April.

To bring the highest price a broiler must be well filled out in the breast and over the hips; in other words, must be very plump.

It should have small bones, an abundance of meat; yellow

skin and legs are preferred, preferably white feathers, and must be forced-fed, making quick growth, thus tender flesh.

The American housewife demands a bird with butter colored shanks and skin which denotes an abundance of fat. This rich yellow is especially found in the Wyandotte, Rocks, and Reds.

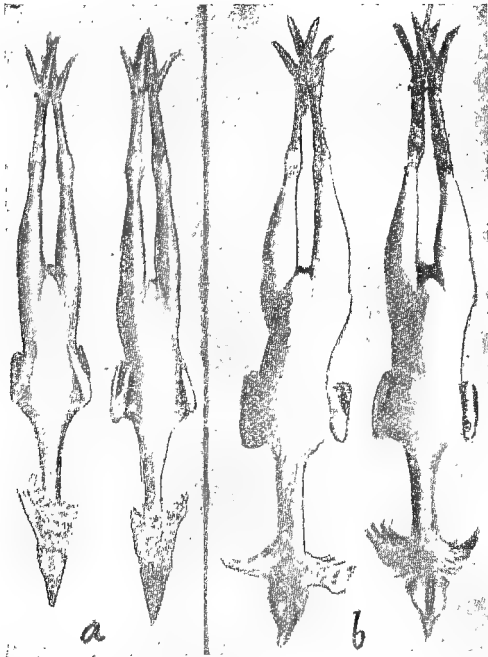

FIG. 122.—Showing two groups of broilers, six months old: *a*, Half-finished; *b*, properly finished.

The general utility of American breeds, as the Barred Plymouth Rock, Rhode Island Red, and Wyandotte, as well as some of the English breeds, as the Orpington, are best adapted to broiler production.

The progeny from these breeds, if of proper vitality and vigor and are properly cared for and fed, should weigh $1\frac{1}{2}$ pounds at twelve weeks old.

Some broiler raisers use White Leghorns for production of the small and medium broilers, because they have white feathers, yellow legs, and mature quickly. They do not develop large, and are not fitted for large broiler or capon production.

A broiler should be raised for a cost of not more than from 25 to 30 cents, and under some farm conditions less than this amount.

A *fryer* is a bird similar to but larger than the large type broiler. The weight usually runs from 2½ to 4 pounds. Usually friers do not bring as high prices as broilers.

Some classifications make three grades of fryers, as follows—light, those weighing 2½ to 3 pounds; medium, weighing 3 to 3½ pounds; heavy, weighing 3½ to 4 pounds.

A *roaster* is a young, quickly developed, and fully grown bird, and constitutes two market types, as follows: small roaster, weighing from 4 to 5 pounds; large roaster, weighing from 5 to 8 pounds.

Prime roasters are in season the entire year, with the highest prices in the midsummer—namely, June, July, and August. The price again raises during the holidays. The carcasses to bring the highest price must be full, plump, and rounded.

The breeds best adapted for the small broiler-raising are the American breeds, as the Wyandottes, Rhode Island Reds, and Plymouth Rocks.

For the large broiler raising the large Asiatics, as Brahmas and Cochins, are slow in developing, but attain the large size desired.

The best roasters are fowls that are full grown and well filled out. If crowded to maturity by proper care and feeding the meat will be soft and in abundance.

The soft roasters of the South Shore of Massachusetts are hatched from August to December. As cockerels are usually sold at a loss, this loss can be avoided by caponizing them and selling them as soft roasters.

By soft roasters is meant a chicken of roasting size that has been crated and fattened with the purpose of placing it in the best possible condition for cooking and eating. The flesh is soft and very palatable.

The breeds mostly used are the Light Brahmas and Rocks.

The cockerels are caponized at about eight weeks old. The birds are ready for market by June or July, when the price for capons is highest.

Capons are usually marketed at from eight to twelve months of age, and weigh from 5 to 12 pounds. Thus we have light capons weighing from 5 to 6.5 pounds, medium capons weighing 6.5 to 8 pounds, and heavy capons weighing over 8 pounds.

Slips are unclassified.

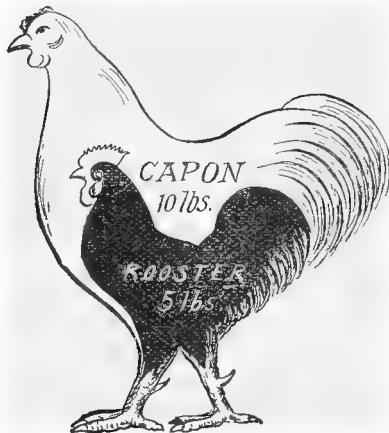

FIG. 123.—Comparative size and weight of a capon and a cock at same age. The cock brings about 15 cents a pound and the capon about 30 cents.

After a pullet has begun to lay her flesh becomes harder, and the same can be said of the flesh of the cockerel as soon as the spurs begin to harden.

Upon the market dressed hens are known as fowls, and average from 3 to 6 pounds.

Cock birds are sold. There is no specified weight or special classification.

The following summary is given which may be of some service.

DRESSED POULTRY

Market classification:

Squab broilers, $\frac{3}{4}$ to $1\frac{1}{4}$ pounds.

Broilers, Medium, $1\frac{1}{2}$ to 2 pounds; heavy, 2 to $2\frac{1}{2}$ pounds.

Fryers, $2\frac{1}{2}$ to 4 pounds; light fryers, $2\frac{1}{2}$ to 3 pounds; medium fryers, 3 to $3\frac{1}{2}$ pounds; heavy fryers, $3\frac{1}{2}$ to 4 pounds.

Roasters, 4 to 8 pounds; medium roasters, 4 to 5 pounds; heavy roasters, 5 to 8 pounds.

Fowls (dressed hens), 3 to 6 pounds.

Cock birds, no weight classifications.

Capons: Age, eight to twelve months; weight, 5 to 12 pounds; light capons, 5 to $6\frac{1}{2}$ pounds; medium capons, $6\frac{1}{2}$ to 8 pounds; heavy capons, over 8 pounds.

Slips (unclassified).

DRESSING POULTRY

Birds to present the best appearance in being dressed should not be fed the day before being killed.

Proper killing is just as important as proper fattening. Unless a fowl is properly killed it cannot be properly dressed. During the twenty-four hours fasting prior to killing the bird should be given water to drink. The water aids in flushing out and emptying the bowel and tends to keep the body plump.

The *dressing-room* should have good light, a barrel should be provided for holding the feathers, and one or more cakes of ice in case of scald pick. The dry-picked birds should be placed in a cooler and kept out of ice-water, if possible. A coop need be provided in which to confine the birds to be killed; a blood-can, to be attached to the head (Fig. 124). For this purpose a tomato-can may be used; about a 1 pound weight is placed in the bottom of the can, a sharp hook is provided, which is attached to the can by three strings, and the sharp end of the hook fastened in the lower jaw after sticking the bird. The blood caught in the can may be used for feeding other birds as it is rich in protein matter. At the large duck farms on Long Island, where many hundreds of ducks are dressed daily, the blood is caught in long troughs and carried in buckets to

the feed mixer and used as a part of the protein portion of the ration.

The *sticking knife* should be provided with a handle about 6 inches long and should be flat. The blade should be about 2 inches long and $\frac{1}{4}$ inch wide, with a sharp point and a straight keen edge (Fig. 125).

A cord is provided to suspend the bird during sticking, bleeding, and picking. The cord is looped around the legs and over a hook overhead or against the side of the wall (Fig.

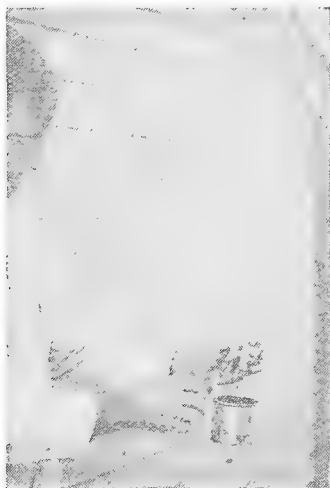

FIG. 124.—Sticking a chicken, using a blood-can (Maine Exp. Sta.).

127). Cross the wings behind and lock the flight feathers of one into the other so that they cannot flutter. Grasp the chicken when killing by the bony part of the skull. Do not



FIG. 125.—A French poultry-killing knife.

let the fingers touch the neck. Make a cut with the small sharp-pointed knife on the right side of the roof of the mouth, just where the bones of the skull end (Fig. 128), which illustrates

the two large blood-vessels which come together or anastomose, and which, when properly cut, allows the bird to properly bleed out. Figure 127 illustrates the proper way to hold the bird in sticking. In dry picking it is necessary to destroy

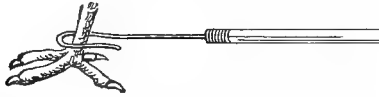

FIG. 126.—A convenient hook for catching birds.

the brain in order that the feathers may be easily removed and prevent tearing the skin. Thrust the knife-blade through the groove in the roof of the mouth, as illustrated in Fig. 128, until



FIG. 127.—Grasping the chicken's head and sticking it.

it touches the skull midway between the eyes. Use a knife that is not more than 2 inches long in the blade and $\frac{1}{4}$ inch wide. The knife should be provided with a thin, flat handle and a sharp point and straight cutting edge. After plunging

the knife into the brain completely destroy the brain by twisting the knife around.

Avoid allowing the bird striking hard objects in its death struggles, as it may bruise itself. These bruised areas reduce the selling price and furnish ports of entry of putrefying bacteria.

Never handle chickens roughly either before or after killing. Rough handling causes bruises, broken bones, scarred skins,

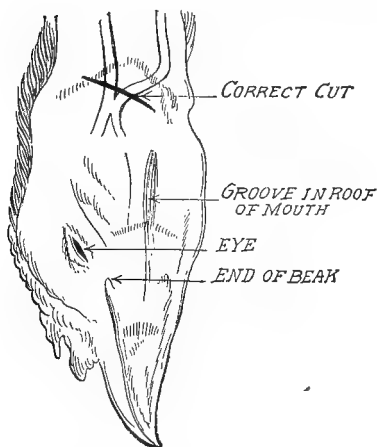

FIG. 128.

FIG. 128. —A diagram of the roof of the mouth, showing the blood-vessels to be cut.

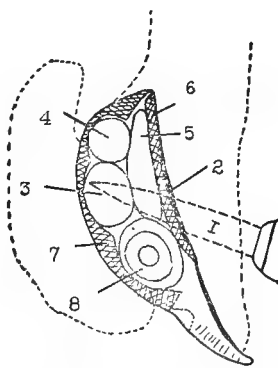

FIG. 129.

FIG. 129.—Destroying the brain. 1, Knife; 2, groove in roof of mouth; 3, the brain; 4, the posterior part of brain; 5, the inferior part of brain; 6, the hard palate or roof of mouth; 7, the upper part of skull; 8, the eye.

and soft places in the flesh. Undue haste on the part of the killers and pickers results in lowered keeping quality and poor appearance of the product.

Piece work which leads to quantity rather than quality makes for lower prices in the market. Those who pay by the piece should remember that chickens sell by the quality of the piece.

Cost of Commercial Picking.—An expert picker as seen in the poultry packing establishments should kill and pick 12

birds an hour. The poultry packing plant usually pays about one cent per bird to the sticker who pulls the larger feathers and then passes the carcass on to pickers who finish picking and pinning. To these latter three cents a piece is paid. An average picker will finish fifty to one hundred broilers a day.

Some pickers remove first the breast feathers, then the thigh feathers, then the back, and last the wing and tail. Others remove first the tail and wing feathers, by grasping firmly and



FIG. 130.—Holding the bird until it stops bleeding.



FIG. 131.—Removing the breast feathers.

giving a quick twisting movement, then the breast at the lower portion, working upward. The breast is easily torn. Next the feathers of the thigh. These feathers are removed by a sweeping or striking movement (Figs. 130–133).

If the neck is discolored and small specks of blood appear, the bird has not been thoroughly bled, probably due to an improper cut. If bleeding stops before the process is complete, scrape the blood from the mouth and stroke downward.

The brain must be punctured and destroyed by the second cut or picking may be very difficult. When the brain is punctured there is a characteristic quiver of the bird.

Cooling.—After dressing a carcass it should be cooled as quickly as possible.

Place scald-picked carcasses in a barrel of cold water and, after about two hours, add ice. After thoroughly cooling

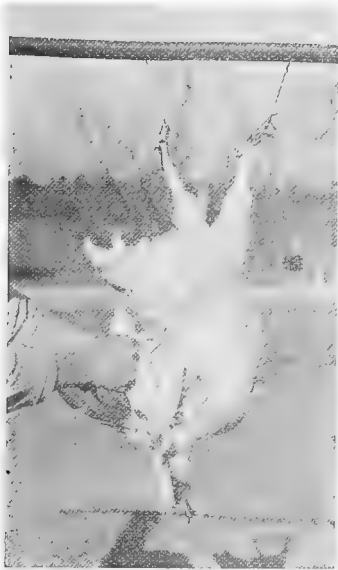

FIG. 132.—Removing the wing feathers.

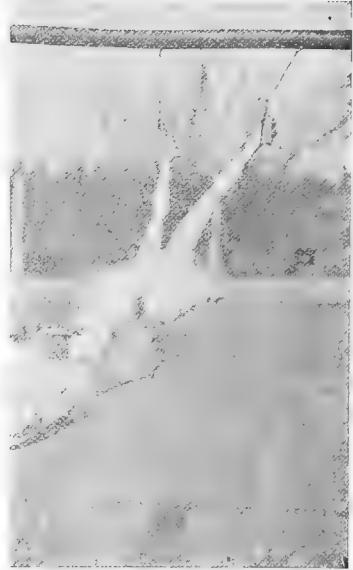

FIG. 133.—Removing the pin-feathers.

allow to drip in a cool room. Wrap the heads in oil paper and pack neatly in boxes holding from one to two dozen.

If summer shipment and no refrigerator car is available, it is better to pack the carcasses with cracked ice, never ice dry-picked if it is possible to refrigerate otherwise.

In *scald picking* water should be as near the boiling-point as possible, at least 150° to 165° F. Pick the legs dry before scalding, hold the head and legs, and immerse and lift up and down five or six times. If the head is immersed, it turns the

color of the comb and gives the eyes a shrunken appearance, which leads buyers to think the fowl has been sick. The feathers, including the pin-feathers, should be removed immediately. (See Fig. 133 for method of removing pin-feathers.) The pin-feathers should be removed very cleanly and without breaking the skin while the body is warm; then plump by dipping ten seconds in water, nearly or quite to the boiling-point, and then immediately in cold water. Place them on a shaping table, as illustrated in Fig. 134.

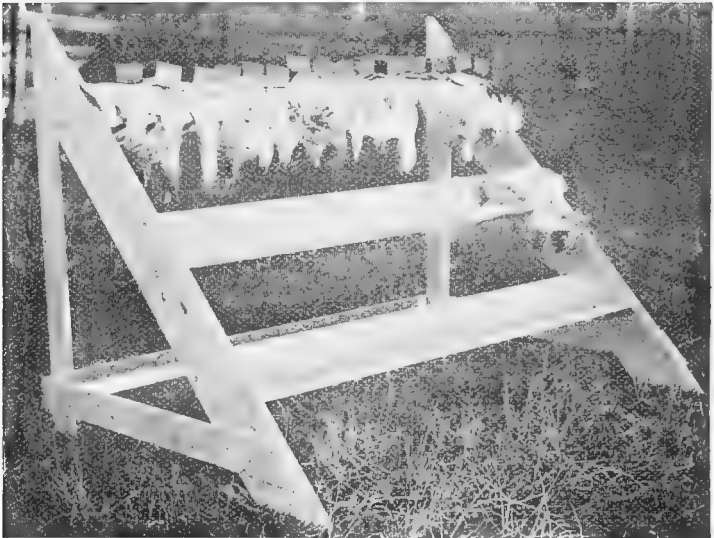

FIG. 134.—A shaping board for dressed poultry. (Dom. Can. Dept. Ag.)

Hanging draws the breast muscles and makes them appear thinner when cold and harder to pack.

The English give the following methods of killing geese: When the hand and arm are not strong enough to dislocate the neck, take the leg and wing ends in one hand and allow the bird's head to lie on the hard floor, the top of the head upwards. Place a thin piece of round iron like a poker across the back of the neck at the juncture of the neck and head. Place one foot over the end of this, then as quickly as possible place the

other foot at the other end of the rod; stand full weight on it, and simultaneously pull on the legs you hold in your hand, and the neck will be instantly dislocated. Do not pull too hard as the head will snap off.

The second method is to hang the bird up by the legs, the head being about 3 feet from the ground; wrap a cloth around the body or lock the wings on the back to prevent the wings from flopping. Then give the bird a blow in the back of the head with a short, heavy stick; when stunned, stick as for fowls.

In cooling plucked geese place on cooling board breast downward. Fold the wings and legs behind the back; place them close together and put a board across the backs. Over this put a heavy weight, as a stone. Wrap carcasses intended for shipment in clean white or butter paper at time of packing. This prevents chafing. Scrub out the mouth and legs and wrap the head in paper.

A shaping board (Fig. 134), is made by putting two boards together at right angles, the lower board sloping slightly upward. The back board should be regulated by the size of the fowls to be pressed.

In placing the picked fowls on the shaping board first press out anything possible from the vent. The hocks are tied together. Turn the carcass with the breast down so that the head and neck hangs off the front edge of the board. Place your thumbs on the back and fingers underneath and hold the legs tightly to the body. Thrust the rear of the bird against the back board with "parson's nose" upward so that it stands erect above the back. Force the hock joints against the back wall so as to make them lie close to the body. In doing this, the skin of the back must not be drawn out of position, or it may be torn; and a tear in the skin reduces the selling price on the large markets. If the row is not full place some heavy object as a large, clean stone against the last bird to prevent the carcasses from spreading, then place a clean board, about 4 inches wide, on top of the entire row of carcasses and weight it down. About three 25- to 40-pound weights will answer. The carcasses are left in this position till cold when they remain in shape and present a short, plump body with full breast.

Capon.—See that the capon is fat. Do not pick the feathers from the neck and head down two-thirds to the shoulders. Leave the feathers on two joints of the wings. Do not pick the feathers from the tail or half-way up the back. Leave the feathers on the legs from the hock-joint to two-thirds of the way up to the hips, the balance of the feathers come off.

Feathers that are removed should be saved, and will sell if kept dry and clean. Wrap paper around the head.

In *dressing ducks and geese* by scalding it requires longer for the water to penetrate and loosen the feathers. Do not pick before killing, as the injury produced to the skin injures the sale of the dressed carcasses. Do not singe the birds after picking, as the heat dissolves the fat and the appearance interferes with the sale of the bird. Before packing for shipment poultry must be cold and dry. The animal heat must be out of the body. The packages, boxes, or barrels must be clean.

Always dry pick *turkeys*. Do not tear the skin. The tail feathers are taken off with a twist and not by a straight pull.

In some localities turkeys are dry picked and shipped to market drawn.

In *picking geese* all the feathers are removed except the last joint of the wing.

Some markets classify dressed carcasses as follows: Chickens up to the stage when the roosters get "staggy," which is told by the development of the spurs. After this age they are classed as cocks. Pullets are classed as fowl after they begin to lay; however, they may be classed as chickens till after they are one year of age. Chickens are divided into squab, or light broiler, and medium and large broilers, springs, roasters, and capons.

Bleeding.—It is estimated that at least 30 per cent. of all poultry coming into New York City market is incompletely bled. Much of it is so badly bled that it results in a loss of from two to five cents a pound, as compared with the corresponding poultry which is well bled and in good order.

Aside from the bad appearance of incompletely bled chickens their keeping properties are very inferior. The flesh looses its firmness sooner; its flavor is not so good; the odor of stale flesh

and, finally, of putrefaction comes sooner, and in every way the product is more perishable.

A very large proportion of the unsightly poultry of our markets, aside from the rubbing and tearing of the skin, is caused by an incomplete removal of the blood. This is evidenced by small red spots which frequently occur where the feathers have been removed, especially over the thighs and wings, or by the small veins which mar the appearance of the neck. Generally, it is the neck which shows most plainly the presence of blood left in the fowl, or that a wrong method has been used in cutting the blood-vessels in an attempt to empty them. The neck is the first part to discolor, becoming first red, then bluish-red or purple, and finally green as aging progresses.

It has been estimated that there is an annual loss of \$75,000,000 on dressed poultry due to improper methods of killing, dressing, cooling, packing, shipping, and handling.

As stated before, if poultry is not properly stuck and bled, the meat quickly deteriorates. By careful investigations by the Poultry Husbandmen of the Department of Agriculture and others it has been determined that cooling in ice-water causes the carcass to absorb water and increases the weight to an amount of about 5 per cent. Too long cooling in water and packing in ice leaches or drains away, and causes a material loss in soluble protein and some loss of flavor. The loss on each carcass is small, but is much on a wholesale lot, and is a loss to the consumer, giving him to that extent an inferior article. It has been estimated that on a carload of 20,000 pounds of dressed poultry, at a price of 20 cents a pound, the consumer loses \$480. Of this loss the packers make \$200, due to increased weight, and \$280 in food values are lost through the draining away of protein.

Dry-picked poultry is superior to scald picking. Scalding disguises poor quality by thickening the skin and plumping the flesh.

Cold storage has been used to hide inferior quality.

Dry-packed poultry is much superior in quality. The difficulty in spring, summer, and in fall is that in many places it is impossible to get refrigerator car service, and in shipping

long distances the carcasses are soon "struck green," as the market men call it, and the fowls are either spoiled or bring a much less price.

Birds dry picked should be cooled in a refrigerator room and, where possible, dry packed and shipped in a refrigerator car, otherwise it will be necessary to ice.

Water should not be allowed to touch the bird from the time it is killed till it reaches the consumer. This means less contamination with saprophytic germs, and, therefore, less decomposition and a conservation of all food elements. Bac-

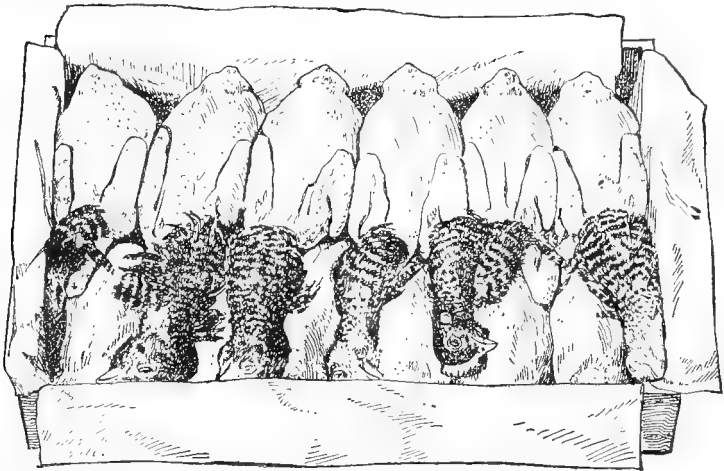

FIG. 135.—Back packing dressed poultry for shipping. (Dom. Can. Dept. Ag.)

teria is a low form of vegetable organism that feeds on meat and thus causes decomposition. When poultry are alive the bacteria do not feed on it, because the animal has a natural resistance.

The temperature in the cooling room and refrigerator is reduced to 36° F. This temperature prevents the development of bacteria.

If the carcass is frozen, a temperature is maintained in the cooler of from zero to 5° F above. Later it is placed in a

higher temperature, but not higher than 15° F., as above that point the carcass would sweat and the flesh deteriorate rapidly. At 15° F. there is no undue loss or shrinkage in weight.

Yellow-legged, white-skinned, and white plumage carcasses sell best.

A tallow-fed bird causes a greasy taste in the mouth when eaten and are not in demand.

Ludlow gives the following as to color of flesh and fat:



FIG. 136.—Side packing dressed poultry for shipping.

All white flesh and fat:

Dorking
Favorelles
Langshans

La Fleche
O. E. Game
Scotch Grays

All dark flesh and yellow fat:

Cornish
Brahmas
Orpingtons
Leghorns

Plymouth Rocks
Malays
Wyandottes
Rhode Island Red.

In packing carcasses they should be graded according to

size and condition of flesh, packing those of one grade in one package.

Before packing, and at the time of dressing, the posterior extremity should be manipulated so as to completely empty the rectum of any fecal matter, as otherwise some of this material will work out and soil the carcasses. Before packing the head, feet, and legs must be washed clean of blood and filth. A small brush will aid in accomplishing this work.

It is estimated that prime fat chickens dress (undrawn) about 92 per cent. of their live weight. Chickens medium in condition dress from 65 to 75 per cent. drawn.



FIG. 137.—Breast packing dressed poultry for shipping.

It has been determined that drawn or partly drawn poultry do not keep as well as undrawn. As soon as the abdominal cavity is opened the carcasses spoil very rapidly unless they are kept at a low temperature.

To summarize, the markets demand that the carcasses of dressed fowl be free from sores, blood, dirt, the bird picked clean, except in the case of capons, squabs, guineas, and pigeons. The small feathers of the head may be left on the bird. No mark of the method of killing should show on the bird.

All pin-feathers should be removed. No food should remain in the crop and all waste matter should be forced out of the vent.

As regards shape the body should be broad, blocky, and of good length. The carcass should present a compact form, well filled out in all parts. A rectangular shape, such as is obtained by proper shaping, is desirable. The legs should be set wide apart.

The flesh should be firm, yet pliable. It should be filled with oil and be soft and of fine texture. Too much fat is a detri-

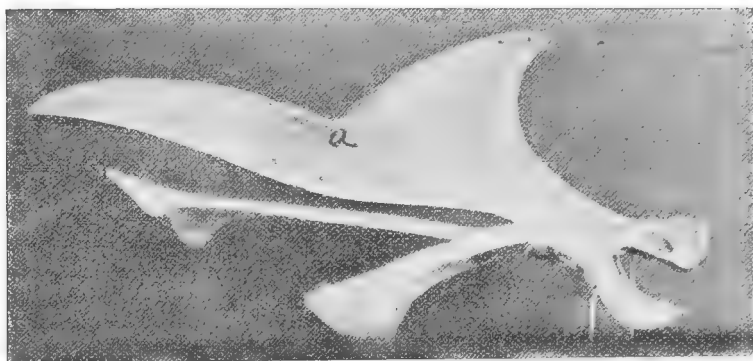

Fig. 138.—A deformed breast-bone causing a deformed appearing breast in the dressed bird, injuring the sale of the carcass: *a*, The depression in the bone due to the young chick roosting on a sharp board.

ment, especially in the abdomen. All bones should be well covered with flesh and fat.

A light-colored skin is preferred, as this usually designates special fattening. It should be fine textured, soft, and pliable. The bird should be dry pickled instead of scalded. No dots or blotches of red should be present, nor any dark rubbed areas. These are the results of poor bleeding or rough handling. Sores, bruises, cuts, and tears are also serious faults. The skin should not be loose and flabby.

The bones should be short and fine.

The breast should be full and rounding, broad, and deep.

The breast-bone should be long, straight, and well covered

with flesh throughout. The breast is the most palatable part of the bird.

Figure 138 is a breast-bone which is deformed as a result of the young chick roosting on a sharp perch. This will cause a deformed appearance of the breast of the dressed carcass and injure the sale. Chicks, when placed in coops for roosting, should be provided with wide, flat roosts, like a 2 by 4.

Figure 139 is a broken tibia or leg bone. Such conditions often cause deformed limbs and injures the sale of the carcass.

The breast should be broad, well fleshed, and straight. It should be of medium length, relative to the size of the bird.

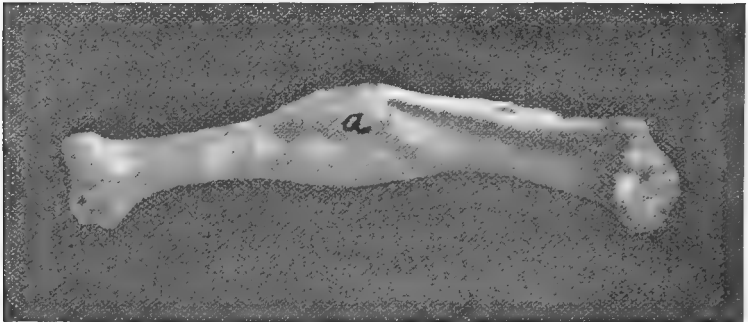

FIG. 139.—A broken thigh-bone. Broken bones often heal crooked and injure the appearance of the dressed carcass: *a*, The break nature has tried to repair.

Straight and long, well covered with flesh throughout. Very important in determining the appearance of the bird.

Short and thick. Thighs should be well fleshed.

Small, well shaped, and drawn up close to the body.

Medium in size, with small, close-fitting comb and wattles. Compact in shape, except in the case of the capon, where it should be long and slender. The comb and wattles should not appear white from scalding.

POULTRY BOX MEASUREMENTS

The National Poultry, Butter & Egg Association, recommend standard sizes for each size-grade of dressed poultry,

and material of White Wood or White Tupelo, nailed—not tongued or grooved.

They advise the standardization of poultry boxes of the following dimensions:

*DRY-PICKED BROILERS, ONE LAYER, BREAST UP

	Length, in.	Width, in.	Depth, in.	Ends, in.	E.T.B., in.
15 lb. and under.....	14	14	4	½	¼
16 @ 20 lb.....	16	15	4	½	¼
20 @ 24 lb.....	16	16	4½	9-16	¾
25 @ 30 lb.....	17	17	5	9-16	¾

DRY-PICKED CHICKENS, ONE LAYER, BREAST UP

31 @ 36 lb.....	19	17	6	⅝	¾
-----------------	----	----	---	---	---

DRY-PICKED CHICKENS, TWO LAYERS, ON SIDES

31 @ 36 lb.....	16	14	7	½	5-16
-----------------	----	----	---	---	------

DRY-PICKED CHICKENS, ONE LAYER, ON SIDES

37 @ 42 lb.....	29	17	3½	⅝	¾
-----------------	----	----	----	---	---

DRY-PICKED CHICKENS, TWO LAYERS, ON SIDES

37 @ 42 lb.....	17	15	7	⅝	¾
43 @ 48 lb.....	18	16	7½	⅝	¾
49 @ 58 lb.....	18½	16	7¾	⅝	¾
50 lb. and over.....	18½	18	8½	⅝	¾

Outside cleats on last three.

DRY-PICKED FOWL, TWO LAYERS, ON SIDES

31 @ 36 lb.....	15½	13½	6½	⅝	¾
37 @ 45 lb.....	16	14	7½	⅝	¾
46 @ 54 lb.....	16½	15	8	⅝	¾
55 @ 66 lb.....	17	16	8½	⅝	¾
68 lb. and over.....	18	17	9	⅝	¾

Outside cleats on last three.

* For any later changes in box measurements, see The National Bulletin, Chicago; or any trade paper.

DRY-PICKED DUCKS, TWO LAYERS (O. S. CLEATS)

	Length, in.	Width, in.	Depth, in.	Ends, in.	E.T.B., in.
42 @ 52 lb.....	20	13½	7½	5/8	5-16
53 @ 62 lb.....	23	14	8	5/8	3/8
60 lb. and over.....	24	14¾	8¾	5/8	3/8

DRY-PICKED GEESE, TWO LAYERS (O. S. CLEATS)

All weights.....	28	19	12	¾	½
------------------	----	----	----	---	---

DRY-PICKED TURKEYS (OUTSIDE CLEATS)

Y. toms, 11 lb. and under....	26	22	12	¾	½
Y. toms, over 11 lb.....	27	25	12½	¾	½
Hens, 11 lb. and under.....	22	20	10½	¾	½
Hens, over 11 lb.....	24	20	11½	¾	½

SCALDED BROILERS, BREAST UP

15 lb. and under.....	14	13	3½	5/8	¼
17 @ 21 lb.....	16	16	4	5/8	¼
22 @ 24 lb.....	16	16	4	5/8	3/8
26 @ 31 lb.....	18	16	4½	5/8	3/8

SCALDED FRYERS, BREAST UP

32 @ 36 lb.....	18	17	5	5/8	3/8
-----------------	----	----	---	-----	-----

SCALDED ROASTERS, TWO LAYERS, ON SIDES

37 @ 42 lb.....	17	15	7	5/8	3/8
43 @ 46 lb.....	17½	15	7½	5/8	3/8
47 @ 54 lb.....	18½	17	8	5/8	3/8
55 lb. and over.....	20	18	8	5/8	3/8

Last three with outside cleats.

SCALDED FOWL, TWO LAYERS

31 @ 36 lb.....	14½	13½	7	5/8	3/8
37 @ 45 lb.....	16	14½	7½	5/8	3/8
46 @ 54 lb.....	17	15	8	5/8	3/8
55 @ 66 lb.....	18	16	8½	5/8	3/8
67 lb. and over.....	18	17	9	5/8	3/8

Outside cleats on last three.

Some wholesale merchants recommend that dressed poultry be packed in barrels, and when the weather is warm and no

refrigerator car service to be had, thorough icing, which consists of placing a layer of cracked ice in the bottom of the barrel, with one layer in the middle and one at the top. When the weather is warm putrefactive changes soon take place.

In answer to an inquiry as to New York City demands, a leading commission firm gave the following advice:

“The New York market requires the birds to be dry picked. There is little sale in New York City for scalded poultry. It is preferable to ship in boxes of twelve to twenty-four. The extremely small fowl, that is, those weighing 3 pounds and under, are not sold readily. Unless the weather is pretty cold the carcasses must be iced, or they will be struck green when they arrive.”

There is another item of vast interest and importance, and that is the Express Companies should make prompt deliveries.

In regard to the New York market, Knapp and von Nostrand says, “There is always a good market in this city except on Saturdays.”

The most desirable weight for broiler ducks is 5 to 6 pounds to the pair, and for roasting purposes 5 pounds or over each.

In shipping to wholesale markets it is necessary to select a reliable commission firm, and ship on the days dressed poultry are most in demand. The shipment should be so made that it will arrive late the preceding night. This will insure the commission man getting the product on the early market next day. If this precaution is neglected one runs a risk of the consignment being too late for market, and becoming fly-blown or bad (in hot weather) while waiting for the next day's market.

If the local market is sufficiently large, it is the best channel through which the small producer can dispose of his product, as he has no icing or carriage expenses to pay. All towns of considerable size have a fairly good market for good grade products.

The small producer will find it exceedingly profitable to build up a good private trade. This can be done by always furnishing a good product. This class of trade usually called for the birds to be trussed and ready for cooking.

Marketing Dressed Pigeons.—In dressing squab pigeons for market they are selected at 3.5 to 4.5 weeks of age or just at a time when they will leave the nest. Up to this time the parent birds have fed them and they are fat, plump and the flesh tender.

On the day squabs are to be marketed catch them in the morning before they are fed by the parents, so that their crops will be empty.

Squabs are killed in the same way as poultry, that is, by cutting the veins in the back of the neck and piercing and destroying the brain. They are then picked and cooled and shipped, iced in barrels.

If they are to be shipped unpicked they are usually killed by wringing or breaking the neck. This is done by placing the thumbs against the place where the neck joins the head.

In picking all feathers are removed except those on the head.

Squabs should be graded according to size, quality, and color of the skin. The carcasses should be packed with breasts up.

TRUSSING

For local trade it is often necessary to prepare the fowl for the oven. This preparation is called trussing. In trussing roasters the carcass is washed and singed, then the tendons are removed by making an incision 2 inches long in the back of the shank, and the tendons one by one are pulled out by aid of a strong hook. This removal of the tendons from the leg greatly improves the quality of the meat of the drumstick as it removes the gristly tendinous portions. Cut the shanks off about 1 inch below the hock-joint. Cut the skin on the back of the neck from a point directly between the wings down to the base of the skull. Separate the bony part of the neck from the "gullet" (esophagus) and "windpipe" (trachea) and cut off the neck just in front of the wishbone. Pull the "windpipe" and "gullet" out and cut off the skin at a point just back of the head. This leaves only the skin of the neck, which is rolled back from the front part of the carcass to expose the wishbone. Scrape the breast muscle from the wishbone and

remove it by aid of a knife. The wishbone removed makes it easier to slice the white meat. The neck flap is now folded over the breast. A small circular hole is cut around the vent, then a 2-inch cut crosswise just back of the posterior point of the breast-bone, and the abdominal organs are removed through this opening. The drumsticks are allowed to project through this slit and out the small vent opening. The wing-bones are folded on the back.

Broilers are prepared by cutting through the backbone, carrying the incision from the tail to the head, and the organs removed through this opening. Or an incision may be made on either side of the backbone from the tail to the head, removing the bodies of the vertebra, neck, and head. By breaking down the sides it is possible to remove the major part of the breast-bone or sternum. The legs are cut off at the hocks and the tendons are removed as in roasters.

The Lancashire Method.—The object of trussing apart from removing the visceral organs is to give the bird an attractive appearance, and to enable it to retain its shape while cooking. In preparing for trussing have ready a perfectly clean board, a very sharp trussing knife, a trussing needle, two 15-inch lengths of thin string, a clean cloth, several squares of clean white paper, and an old bucket for the waste matter.

Drawing.—Start with the bird on its back with its feet toward you. Cut off the toes at first joint and entire back toe. For older birds make a slit down outside of shank before cutting toes, and with a skewer or trussing needle twist the sinews, drawing them toward the foot. They will come loose easily from the top of the leg, and then the toes may be cut. Trim off the loose skin round the outside edges of the wings. Remove top joint and digit of wing.

Lay bird on breast, feet toward you. Pinch up skin of neck and make a deep cut along the back, about 2 inches wide and 3 inches deep, to form a flap, which will subsequently hide the hole made on the removal of the neck.

Cut through bone of neck, about 1 inch from the juncture with the body (not right at the joint, or the length of breast will be curtailed and an ugly gap show between the shoulders).

Do not cut through the underneath skin, but, having severed the bone, cut off 2 inches nearer the head.

Separate out and cut off head and neck, saving the neck and laying to one side. Remove by peeling out the crop, cutting off as far down as possible, from the tube extending down into the body. Insert two fingers through the neck hole. Pass entirely round inside the fowl to loosen all organs. Particular care must be taken to loosen the lungs, which cause the bird to decompose quicker if left in. To do this the trusser must work carefully toward the backbone between each rib of the four nearest the neck, on either side.

With the back of the trussing knife rap the joint of each shoulder sharply to break it. Wipe the flaps and surroundings flesh clean and fold the flaps evenly over the opening, the back flap coming forward and inside, and the front flap being held in place by folding back the wings that they may lie flat across the back, the flap being under them.

Stand the bird on its end, tail upward and feet toward you. With cloth, take firm hold of opening to intestine, and, with a sharp-pointed knife, cut in a complete circle round the vent, taking care to cut around, not into, the intestine. Into the cut, beside the intestine, insert fingers, pass round to loosen organs, take firm grip of gizzard, and draw all organs out in a pile on the board.

Separate the heart, liver, and gizzard. Cut a slit along the outside edge of the gizzard, taking care not to cut too deep, pull apart and remove the grit bag.

Thread the needle with one of the pieces of string, press legs firmly forward toward head, and at the commencement of leg insert needle, drawing out an exactly same point on the other side. The legs should be even. Insert the same needle and string through the space between the two wing-bones, then under and up through the skin of the fore wing. Proceed in the same manner with the other wing, beginning with the fore wing and ending between the bones of the wing itself. Tie ends of string tightly together at the starting-point. Rethread the needle, pass through skin at point of breast-bone, through hole in breast-bone, and out at same point on other side. Over the leg and through the hole in the hip, out on opposite side of

body, in under skin, over leg to breast-bone, through breast-bone again, and out of the original hole. Cut thread. The string should be hanging in equal lengths on each side of the breast-bone. Tie strings tightly behind legs, draw parson's nose down, and tie firmly in a knot on back. Cut ends short.

The Sussex Method.—Cut off shanks at knee-joint. Manipulate neck and loosen, as in the Lancashire method.

Make a small shallow slit horizontally between the tail and vent, insert little finger, hook the intestine by passing finger round inside vent, insert knife point where finger is and cut outward. Finish drawing as in above method.

Trussing.—Insert needle through space between two wing-bones, over flap of skin, and through between opposite wing-bones. Pull legs well forward, and pass needle through body at commencement of legs and out the other side. Tie tightly at starting-point. Rethread. Pass through parson's nose and twist string round to make it firm; pass over legs, cross behind, and tie ends tightly. A small slit is made in the wing, and the liver inserted through one wing and the gizzard through the other.

Boning Fowls.—With a sharp knife make an incision through the skin in the back of the neck. This incision is carried down to the base of the neck. After this incision down the neck is made, work out the neck separating it from the skin and surrounding structures and cut off at the head. Then cut off the neck at the base. Cut off the neck skin close to the head. After the removal of the head and neck, the next step is to remove the feet and shanks by unjointing at the hock. Before doing this slit the skin at the back part of the shank, work out the tendons, place over a hook and pull the tendons out from the muscle of the tibial or drum stick region and the legs will thus be free from "gristle" or tendons when cooked for table use. It is not necessary to remove the intestines for boning. After removal of the neck and shanks set the carcass on the posterior end, make a cut on each side of the two wings of the wish-bone, cut loose its attachments and remove. Next cut down and disarticulate the wings at the shoulder joint. Later the wing bones can be removed. One method is to leave the wings and thigh bones in but this is only partial boning.

It is more satisfactory to remove all bones. Next gradually work off the flesh from the body skeleton by gradually scraping downward with the knife. Hold the knife at an angle against the bone. Turn the skin with the flesh over in a roll, like taking off a glove, by stripping downward. By this means the bones can be stripped clean of meat. After the meat has been removed down to the thighs disarticulate the hip joints. The thigh bone and tibia can be removed later. It is now an easy matter to remove the balance of the flesh from the body case. The wing and leg bones are now easily removed by stripping the skin and flesh in the same manner as taking out the body case. After the bones are removed the meat can be tied at one end stuffed with dressing and the other end tied and after cooking it may be served on the table in slices making each slice contain dark and light meat and dressing. Or, the meat can be rolled, baked, and then served in similar slices without the dressing added.

Loss in killing and dressing is illustrated in the following which is the result of one test:

Live weight.....	348	pounds.
Dressed weight (picked and bled).....	306.8	"
Loss.....	41.2	"
Per cent. loss.....	11.8	"

This includes the weights with the heads and feet on.

Trussed weights vary according to grade and condition of the carcass. The breed as well as the age is also a factor. Usually the trussed weight will range from 65 per cent. in thin fowls to 88 per cent. in fat hens.

The percentage of edible meat varies with the breed, age, and condition of the carcass. In fat birds about 60 per cent. is found to remain after boning.

The percentage then that consists of head, bones, and shanks varies with the age and condition of the bird, but may be only about 13.85 per cent. of the live weight in the very fattest birds and increase in percentage in birds not fat.

The following score-card is recommended for student use:

THE CORNELL SCORE-CARD FOR DRESSED POULTRY

Disqualifications.—Unmistakable signs of disease, sore spots.

Valuation section	Name of section	Remarks
15	Appearance.	Free from sores, not scalded, clean, well picked, well shaped and prepared, and having a young appearance.
5	Size.	Medium.
5	Head.	Small, with small, close-fitting furnishings.
10	Body.	Rectangular in shape, wide between the legs.
5	Wings.	Small, tucked up.
5	Back.	Broad, medium in length, well fleshed, not roached.
10	Shanks and legs.	Short and thick.
10	Breast.	Full and rounding, broad, well covered with flesh throughout.
15	Keel.	Straight and long, not bending, well covered with flesh throughout.
5	Bone.	Small and fine.
15	Skin and flesh.	Soft, fine textured, medium to loose, flesh not flabby, not too much fat, especially in the abdomen. Color, yellow or white, according to variety, yellow in this country being preferable.
100		

CHAPTER XIX

THE CARE AND MARKETING OF FEATHERS

THERE are dealers who buy feathers. The prices vary according to the condition of the feathers and the quality. Pure white feathers bring a higher price than mixed or dark feathers.

All body feathers will heat if sacked up before being thoroughly aired and dried. The stock may be apparently dry when shipped, but unless the animal heat has been thoroughly removed the feathers will heat and mold in a short time. It is, therefore, necessary to spread all body feathers on a clean floor, not over 4 to 6 inches thick, and turn them every day until dry. They must have plenty of air, except in extreme weather.

In many of the large establishments the buildings have their rooms floored with tonged and grooved flooring, and the walls and ceiling covered with tonged and grooved ceiling material. The most of these ducks are scald-picked. The feathers are then taken to these rooms and spread out in a thin layer and beat up with a long slender stick once a day till dry. The workmen find that if they stay in these rooms too long at a time they suffer from a catarrhal condition of the nasal passages, which appears to be due, at least in part, to a volatile fatty material which enters the air while the feathers are agitated. It apparently irritates the mucous membrane of the nasal passage, producing a thickening of the mucous membrane. If wet feathers are not beat up regularly while wet they become dried in lumps, which causes a reduction of the price when put on the market. If properly beat till dry, all the feathers fluff out and present a pleasing appearance.

All chicken and turkey body feathers should be kept separate.

All quills should be kept out of the body feathers .

All quills, and particularly tail quills, should be thoroughly aired before packing. To bring the top market price they must be thoroughly dry.

In plucking the short quills, pointers, tails, and wing feathers should be separated, having a receptacle in which to throw each



FIG. 140.—A collection of market feathers, showing the different grades. Note the difference in appearance between the dry and scald picked.

kind. It will save much labor if this be done and will not require more time of the picker.

The packing of stock should be looked after carefully. Quills should be packed in boxes, each kind separate, and care taken to get exact tare of the box and cover. If quills are shipped any great distance sacks can be used, provided they are good ones and the quills are laid into them as straight as possible. Quills should not be dumped into bags without regard to condition.

Most large shippers pack and ship body feathers of ducks and geese in white muslin sacks, the sacks being thirty inches wide and seventy-two inches long, and chicken body feathers in sacks 30 inches wide and 75 inches long. The sacks should be burlaped. The weight is approximately one hundred pounds. Quills and other grades are also shipped in sacks.

In shipping see that each and every bag or box has your shipping tag or mark, with gross weight and tare. Your letter of advice to the buyer should have full particulars, separate weights, tare, and net weights. In order that the goods be handled quickly the buyer considers this very important.

In regard to freight rates it may be of interest to the reader to know that the price of feathers is so low in some grades and the freight rate so high that it leaves very little profit after cost of handling and packing is paid. The freight rate from Raleigh, North Carolina, to Cincinnati, Ohio, is $1\frac{1}{2}$ cents per pound, and as the prices in the following list is "delivered in Cincinnati" it can be seen that the profit would be small. The distance from Raleigh, North Carolina, to Cincinnati is 569 miles.

The following is a quotation sheet from a well-known feather merchant of Cincinnati, which was issued February 17, 1915, and will serve to give the relative value of each kind of feathers as well as the market grades.

Geese Feathers

Pure white.....	\$.65
Good average white.....	.55
Largely gray.....	.47
Largely gray, scalded.....	.35-.40
Long goose-quills.....	.07

Duck Feathers

Pure white.....	\$.42-.45
Stained and scalded white.....	.35-.40
Dark.....	.35
Dark, scalded.....	.25-.30

Chicken Feathers

Body, dry picked, all white.....	\$.12
Body, dry picked, dark.....	.02½-.03
Damp, scalded, musty or very quilly.....	.01½-.02
Hackles (no quills).....	.05
Hen quills (clean).....	.01
Rooster tails, long fancy (free of stiff feathers).....	.50

Turkey Feathers

Body, dry picked, all white.....	\$.15-.20
Body, dry picked, dark.....	.02½-.03
Tails, dark, no skirts.....	.25
Tails, dark, with skirts.....	.15
Wings, no shorts.....	.10
Wings, with shorts.....	.06
Tails and wings, dark, no shorts.....	.15
Tails and wings, dark with shorts.....	.07
Tails, wings, and pointers, no shorts.....	.09
Tails, wings, and pointers, with shorts.....	.07-.08
Wings and pointers.....	.05
Pointers, dark.....	.01
Shorts and skirts, free of body.....	.02
Tails, pure white and clean.....	.25
Wings, pure white and clean.....	.10
Pointers, pure white and clean.....	.01

Note.—To get top prices quills must be straight and clean.

All feathers freshly packed and damp are discounted according to condition on arrival.

Picking Live Geese.—Geese may be picked every six weeks if the picking is done regularly. Each Toulouse goose will yield one pound of feathers. In the winter geese are picked only on the breast.

The following tabulation is a summary of the amount of feathers yielded by different fowls.

Kind of birds	Average weight of bird	Feathers green, pounds	Feathers cured, pounds
Broiler ducks.....	5 4	0.18	0.126
Cocks.....	5.3	0.20	0.160
Hens.....	5 3	0.18	0.130
Squab broilers	1 2	0.05	0.037
Medium broilers	1 8	0 09	0.069
Heavy broilers	2 3	0.10	0.079
Light fryers.....	2 8	0.10	0.085
Medium fryers.....	3 2	0.12	0.079
Heavy fryers.....	3 8	0.14	0.089
Roasters.....	4 7	0.21	0.172
Totals.....	35 8	1 37	1.026
Mixed averages.....	3 58	0 137	0.1026
Ten birds.....		1.37	1.026

From this we can expect that each ten mixed birds will yield about one pound of cured feathers.

CHAPTER XX

PRESERVATION OF POULTRY MANURE

THE manure obtained from the poultry house is very valuable. It should not be allowed to accumulate too long beneath the perches, and when collected it should be saved until it accumulates in sufficient quantities to be used as a fertilizer.

The Maine Station determined that the average night droppings of the medium breeds amount to 30 pounds per fowl per year. On this basis 100 fowl would produce 3000 pounds, or $1\frac{1}{2}$ tons.

The average composition of fresh manure is given as follows: Water, 57 per cent.; nitrogen, 1.30 per cent.; phosphoric acid, .85 per cent.; potash, .30 per cent.

From this analysis it will be seen that hen manure is rich in two of the three principal fertilizing elements. If the plant-food contained in a ton of average fresh poultry manure was bought at the price usually paid for it, in the form of commercial fertilizers, the outlay would be about \$7.50.

Taking into account that the quantity of manure produced in the daytime is at least that produced at night, we find that manure voided in a year by a single average hen is worth about 30 cents.

Hen manure contains nitrogen in a quickly available form, and, if fermentation is allowed to go on unchecked, a large part of the nitrogen escapes into the air in the form of ammonia gas.

The composition of hen manure varies to some extent, according to the food eaten by the fowls. Hens fed on animal matter containing considerable quantities of bone will void a manure rich in nitrogen and phosphoric acid.

Poultry manure should be preserved in a dry state. It can be kept in an old house. The building in which it is kept must be provided with a good roof. It is essential to, so far as pos-

sible, prevent the escape of nitrogen into the air in the form of ammonia. In order to do this the droppings must be deprived of a part of their moisture as soon as possible. This can best be done by mixing some dry material with it which will act as an absorbent. It is a good plan to spread an absorbent on the dropping boards. Those materials giving the best results are sifted coal ashes, land plaster or gypsum. Enough of the material should be used to dry up the moisture. Wood ashes and lime should not be used, as they set the nitrogen free. The storage-house should have a floor and cracks that will allow air to pass into the mass of manure so as to ensure that it be kept dry. The building must not leak, as wetting the manure should be guarded against.

The best results will be obtained if it be used at once on the growing crops. If manure be placed on the bare ground during the winter months, fully one-half of the fertilizing value will be lost through leaching.

Poultry manure can also be stored in boxes and these boxes be kept dry in a place. Holes bored in the sides of these boxes will, to a certain extent, allow of a circulation of air through it and prevent fermentation.

Poultry manure makes an excellent fertilizer for grass and fodder crops. For top dressing it is recommended to mix 1000 pounds of hen droppings, 60 pounds of superphosphate, and 40 pounds of potash. For raising garden truck, mix 1000 pounds droppings, 250 pounds superphosphate, 100 pounds sulphate of potash. We are told that this formula is equal to fertilizers ordinarily sold at \$40 a ton.

For a fertilizer for corn use 1000 pounds hen droppings, 40 pounds superphosphate, and 100 pounds muriate of potash. Of this mixture use $\frac{1}{2}$ ton to the acre of corn and 1 ton to the acre of oats.

For mangles, use on each acre of ground 3000 pounds of hen droppings, 750 pounds of superphosphate, and 300 pounds sulphate of potash.

It has also been recommended that to each 30 pounds of fresh droppings there should be added 10 pounds of sawdust, 16 pounds of acid phosphate, and 8 pounds of kainite. In this the sawdust absorbs much of the moisture, and the acid

phosphate and kyanite prevents, at least to a certain extent, the loss of nitrogen.

The above gives a balanced food for plants, as hen manure in itself does not provide the proper balanced plant ration.

The Michigan Agricultural Experiment Station gives the following analyses:

TABLE 1.—AVERAGE COMPOSITION OF MANURES IN POUNDS PER TON

	Nitrogen, pounds	Phosphoric acid, pounds	Potash, pounds
Horse manure.....	11	5.5	13.2
Cow manure.....	9	6.0	8.4
Cattle manure.....	11	6.9	9.6
Sheep manure.....	20	8.9	16.8
Hog manure.....	13	12.6	9.6
Hen manure.....	18	17.4	9.6

TABLE 2.—VALUE OF FERTILIZING CONSTITUENTS IN ONE TON OF MANURE

	Horse	Cow	Cattle	Sheep	Hog	Hen
Nitrogen.....	\$1.98	\$1.62	\$1.98	\$3.60	\$2.34	\$3.24
Phosphoric acid.....	0.27	0.30	0.34	0.44	0.63	0.87
Potash.....	0.66	0.42	0.48	0.84	0.48	0.48
Total value per ton	\$2.91	\$2.34	\$2.80	\$4.88	\$3.45	\$4.59

TABLE 3.—AMOUNT AND VALUE OF MANURE PRODUCED IN ONE YEAR

	Amount, pounds	Value
Horse.....	14,900	\$23.70
Cow.....	24,800	29.50
Sheep.....	1,460	4.10
Hog.....	2,550	2.55
100 hens.....	3,100	6.90

CHAPTER XXI

SELECTING EGGS FOR SITTING

IN selecting eggs for sitting only well-formed eggs should be selected. Do not select the eggs with a ridge around the



FIG. 141.—Eggs suitable for sitting are shown in the right-hand compartment. Note uniformity of size. In the left-hand compartment is a collection of eggs not suited for sitting. Note some are small (*a*), narrow (*b*), and elongated, some are round (*c*), thin shelled, and wrinkled (*d* and *e*).

middle, or that are small, or that have a thin shell, or small end enlarged, or that is short and round, or that is abnormally long and much under size. Remember that you cannot get larger chicks out of the eggs than the size of the eggs (Fig. 141).

The average-sized hen egg is about 2.27 inches long and 1.72 inches in diameter. Illy shaped eggs should be discarded, as the progeny is not desirable and they bring a low percentage hatch. No eggs weighing less than 2 ounces should be used, as the markets of the future will grade according to weight per dozen and, in fact, at this time many of the large markets are making such differences. The size of the egg is a character that is inherited, and we do not expect that the hen developed from an undersized egg will lay one any larger, besides she herself in body may be smaller as a result of coming from an undersized egg.

Eggs for sitting should not be over two weeks old. The eggs should be kept in a cool place, as a cellar. Incubation begins at a temperature of 68° F., so that the eggs must be kept at a temperature below 70° F.

Hauling them over rough roads, especially mountain roads, causes such jarring or concussion that the delicate membranes surrounding the yolk or whites break and a so-called "addled" condition results. In such an egg one can hear the contents shake or slush, and it would be unfit for sitting purposes. This also decreases its value on the market as a product for food and lessens its keeping qualities.

As stated before, the yolk has a tendency to float to the top of the egg. On the top surface of the yolk the tiny embryo, or blastoderm, which is, in reality, the quiescent embryo, is located. If the yolk is allowed to gravitate to the top of the albumen in the egg, upon reaching the surface, and as a result of the evaporation which is going on from the egg, the blastoderm will become adherent (dried fast to the shell membrane) and will die. Hence, eggs for sitting should be turned daily to prevent the yolk from raising to the surface.

The finishing touch nature puts on the egg in the egg canal before it is laid is to cover it with a varnish-like substance, which is commonly known as the bloom. Washing destroys this bloom. The so-called bloom is a protective coating. It is apparent from experiments carried on that after the removal of this outer coating or bloom there is a more rapid evaporation from the egg, and hence more chicks die in the shell and those that hatch would be less vigorous.

To summarize, eggs for hatching should be uniform in size, fully up to the standard weight, proper color and shape, dis-



FIG. 142.—A good way to ship large quantities of eggs for sitting. Each egg is wrapped in paper with a small wad of excelsior around them. In this manner the breakage should not be more than 1 per cent.

carding all cracked, ill-shaped, rough, thin-shelled, and extremely dirty eggs. Remembering that severe shaking over

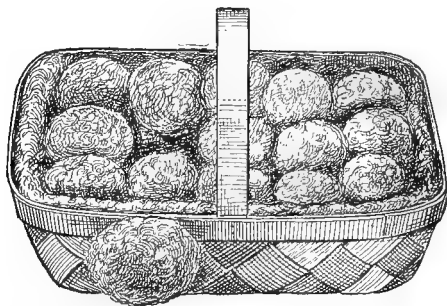

FIG. 143.—Basket filled with eggs wrapped in excelsior in preparation for shipping.

rough roads, breaking the delicate membrane within, renders the eggs worthless for hatching.

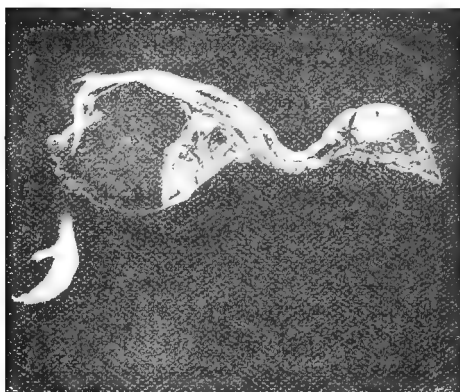

FIG. 144.—Abdominal yolk, the baby chick's food. Note the abdominal yolk nearly filling the abdominal cavity of top chick which is just hatched. In the middle picture the arrows point to the yolk sac, the left from chick 43 hours old, the right from chick 77 hours old. The lower chick 108 hours old and next above 96 hours old.

White shelled eggs possess a higher percentage of fertility, and of the fertile eggs there will be a higher percentage of white eggs hatched than of brown shelled eggs.

Brown eggs have a thicker shell and will require greater pressure to crush than white eggs.

Strength of Egg Shells.—Mr. Herrasti of South Africa tested the longitudinal strength of egg shells. Nature has made wonderful provision to protect against the breakage of an egg by the use of the arch. In these tests brown eggs proved stronger than white-shelled eggs. As an average the brown eggs broke under a pressure of 155 pounds and the white shelled eggs broke under a pressure of 112.5 pounds. The thickness of these shells varied from 0.013 to 0.014 in. The thickness of the shell will vary with many factors, but if the hen is normally functioning and plenty of shell material is provided, but few thin-shelled eggs should be produced. It is safer to keep these for home consumption than to take chances on breakage in transporting.

If a common market basket is used to ship eggs, line the sides, end, and bottom with excelsior, wrap around each egg paper, cotton, or excelsior until the mass is about 3 or 4 inches in diameter. Pack these tightly in the basket, covering with excelsior and cloth; the cloth can usually be forced between the rim and the basket, using an old case knife to force it in. The basket should be labeled, in large letters, "EGGS FOR HATCHING"—"HANDLE WITH CARE."

Eggs for hatching shipped either by parcel post or express may be subjected to rough handling. Therefore the delicate mechanism of the egg may suffer serious injury as a result of concussion. Even the delicate retaining membranes may be ruptured without breaking the shell. Therefore the explanation of why eggs shipped by parcel post or express for sitting purposes do not hatch so well is injury due to concussion.

Many commercial men estimate that 65 per cent. of the eggs set is an average hatch.

In packing eggs for hatching it is necessary to have a material that will be "springy" so that the concussion will be taken up and the eggs not jarred so as to seriously injure them. The best wrapping materials are felt, excelsior, or soft paper.

CHAPTER XXII

INCUBATION

INCUBATION is done by either natural or artificial means.

In artificial incubation either a small or a large incubator may be used. The small single compartment type is heated by hot water or hot air, by gas, oil, or electricity. Either hot air or hot water systems may be used. The large incubators are heated by electricity or hot water, by gas, oil, or coal.

Incubators, with many compartments are called mammoth incubators, which may be heated by gas, electricity, or coal. The water system is used when coal or gas is used as a fuel.

Incubation	{	Natural	{	Hen		
		Small (Hot water or hot air)	{	Diffusion		{
			Radiation	{		Oil
	Artificial	{	Mammoth (Hot water or electric coil heat)	{		Coal
					Gas	
					Electricity	
					Oil	

Time Required for Hatching.—The number of days necessary for hatching or incubation of eggs of the various kinds of poultry are as follows: Fowl vary from nineteen days for the light to twenty-one days for the heavy breeds. Geese average thirty days, varying from twenty-seven to thirty-three days. Turkeys, twenty-eight days, varying from twenty-six to thirty days. Ducks average twenty-eight days, varying from twenty-six to thirty-two days. Guineas average twenty-eight days, varying from twenty-six to thirty days. Pigeons average seventeen days, varying from sixteen to twenty days.

Chick Production.—Strong, healthy chicks can be produced only from the right kind of eggs. It will be observed that eggs vary in size, shape, and color, as well as in inherited

qualities, all of which must be determined by the careful selection of the breeding stock.

As a rule, all other factors being equal, the heavier the egg the more vigorous the chick. A small egg may produce a small runt. Mature stock should be selected for breeders. It is not good policy to select immature cockerels, much less immature pullets. Pullet eggs are small, and the same sometimes holds good of hens that are old and going through the molt. Eggs at such times and under such conditions should not be used for hatching purposes. As a rule, eggs laid in February and March average heavier than at any other time of the year. There are many reasons why the hatch should be early. It means early maturing progeny, which means early fall layers and ready for breeding the coming season. It means that the broilers can be marketed earlier and bring a higher price than those marketed later in the season.

Some of the reasons why chicks die in the shell are that the eggs are from birds of low vitality, old, decrepit, and impotent. The birds must not be allowed to become too fat by lack of exercise. Immature birds must not be selected for breeding, and too many females must not be placed with each male bird. The proper feed must be supplied and the birds must be kept in sanitary quarters, with the house properly ventilated. The birds must be kept free from vermin (lice and mites), as vermin saps the birds of their vitality. Eggs must not be kept too long before incubation or at a temperature too high. Proper methods of incubation must be used. In the heavy breeds ten or twelve females may be kept with one male, and in the lighter breeds twelve or fifteen, provided the males are young and vigorous. Less number should be kept with older males. Eggs should be kept cool and should be turned daily, and not be more than two, and at the outside not more than three, weeks old when set. Hens should be fed sufficient feed, and the ration should be properly balanced. The breeders must be in good, vigorous condition in order that the progeny be strong and vigorous. A hen that has been laying for a long time is somewhat reduced in vigor. Reproduction is one of the most exhaustive processes of nature. Anything that reduces the vigor of the mother reduces the vigor of the off-

spring. One should not breed from birds depleted by disease or vermin. The breeding stock should not be expected to lay heavily during the preceding winter, should have exercise, must not be frightened, and the sanitary surroundings be good. The germ becomes weak as the egg becomes older, hence we should not expect as vigorous chicks from eggs three or four weeks old as from those three to four days old. Eggs of ill shape, under size, mottled, and thin shelled should not be selected for sitting.

Tests show that when breeding hens are fed scantily the fertility of the eggs will be low, but those that are fertile hatch as well as those from hens fed abundantly. It rather indicates that after a hen has been laying heavily for a while her eggs may be less fertile. There is apparently no difference in the vigor of the chicks from the two lots of fowls. Chicks hatched from eggs laid by fowls fed liberally average somewhat heavier than those hatched from the other eggs.

Eggs from White Leghorns do not reach their maximum weight until the hens are in their third laying season.

In incubation the eggs need plenty of oxygen, the proper temperature maintained; too much cooling slows down the vital processes and is injurious. After the third day it is necessary to turn the eggs once a day to avoid cripples and dead chicks; the eggs must lie on their sides or slightly inclined with large end upward and not on the ends. Many practise cooling and airing the eggs once a day after the third day—at first only a few minutes, gradually increased to forty minutes, in a warm room.

Baby chicks have a habit of huddling and dozing in the sun's rays and moving as the spot of sunshine does. Finally when the sunshine disappears they are likely to remain in this position and become chilled. Do not allow this, as congestion and bowel trouble may follow such a chill. Watch the chicks closely and require them to return to the hover to doze and rest. The baby chick needs plenty of food, drink, rest, and sleep.

Either overheating or chilling may cause diarrhea and cold in the head, also congestion of the lungs and kidneys or pneumonia.

On the whole, it may be said that the first four weeks of a chick's life is the most critical period.

The majority of the chicks of the flock that are alive at the end of four weeks will live to maturity. As a rule, with those unexperienced and with limited time more chicks may be hatched and reared by use of the hen.

How to Sit a Hen.—The best type of hen to sit is one of medium weight, such as the Rocks, Reds, Wyandottes, and Orpingtons. The light breeds that flit and fight break eggs and are poor sitters. The first sign that a hen wants to sit is that she remains on the nest longer when laying, later she does not leave on being approached and will ruffle her feathers, cluck and even pick at the intruder.

For early hatching a hen with much body fluff is to be desired.

Sit at least six hens at one time. A box for the sitting hen should be about 16 inches square with a board 5 inches wide at the lower portion of the front to give support to the nest. Make the nests out of excelsior or soft straw, as oat straw or wheat straw. Work the straw down carefully so as to make a well-rounded nest, with no low corners for the eggs to roll into and become chilled. Leave no sharp straws projecting up so as to prick the hen and make her irritable. Prepare the boxes in a partially darkened room and away from other birds or animals that may trouble them. Make the boxes low, so the hen will find no trouble in getting in and out with ease. Keep feed and water before her at all times, so that she may easily procure water and feed when she so desires and can immediately return to the nest undisturbed. If an egg becomes broken, secure a pan of warm water and dip the eggs that are smeared, removing the portion of eggs with as little rubbing as possible. The egg-shells are porous so as to allow oxygen to pass through from the atmosphere to the developing embryo which must have oxygen, and to allow the escape of carbon dioxid, which is a poisonous gas given off from the developing embryo as in all animal life. If the egg becomes smeared with albuminous material, as in the case of broken eggs, and this substance dries on the outside of the shell, it may seal enough of these pores to prevent oxygen entering and carbon dioxid leaving the eggs and the embryo dies.

It may also be necessary to remove some of the straw and replace part of it, as it is likely to become more or less soiled.

In incubating, since the yolk carries the germ on the upper side, heat should be applied from the top and not from the bottom.

Heat, moisture, and oxygen are the three prime essentials in incubation.

Hens should be set on the ground to ensure proper moisture. The combination sitting and brooding coop may be used, when the earth is made into a mound with the nest on top of this and the coop set over this. In this way the nest does not become flooded with water during rainy times. In colder parts of the year a board floor lying in contact with the ground is used. A frame box 8 inches high, and 16 inches square is used. If the hen's nest be fouled it should be cleaned. Sitting hens should be fed solid grain and a variety. They should be allowed an abundance of clean fresh water. They should either be in an inclosure and allowed to come off at will, or if more than one hen is in a nest in the same inclosure there will need be a special half hour set apart to let them off. Hens do not always go on the right nest when more than one is located in the same place.

To test a hen before sitting her place the hand under her, and if she shows signs of broodiness and is gentle, which is shown by the fact that she does not fight and flit around but settles over your hand, she will be reliable. Never sit a hen till she has shown broodiness two or three days and has become accustomed to the nest.

Candling the Eggs.—In candling the light used may be lamp, gas jet, electric bulb, or sunlight. Some candlers are provided with reflectors.

As stated before, it is advisable to sit no less than five or six hens at one time. When a large number of hens are kept in one room keep them shut up and leave them off once a day, keeping close observation to see that each one goes back on the right nest, as the eggs should not be exposed in ordinary weather for more than twenty or thirty minutes, and in cold weather a shorter period. At the end of from five to seven days the eggs should be candled, as shown in the illustration of

candlers. A home-made candler can be made by taking a box made of paste-board, the size a pair of shoes comes in, and cut an oval hole three-fourths as large as an egg in the center of the bottom of the box. Then cut a hole about 2 inches in diameter in one end of the box. Place a lamp in the box, with hole in the end of the box at the top of the chimney. Place the lid

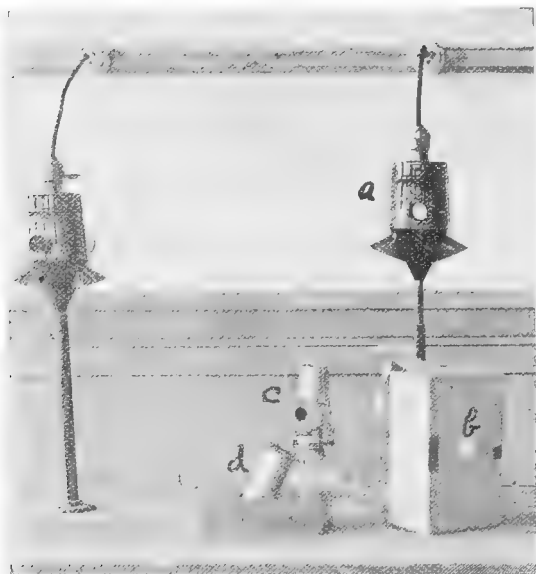

FIG. 145.—Different types of egg candlers: *a*, The commercial egg candler as used in wholesale houses; *b*, the boys and girls poultry club type, made from a shoe-box and a small lamp; *c*, a tin globe egg candler; *d*, a candler provided with dry cells and a small electric bulb.

on so as to make the interior of the box dark. Light the lamp before placing it. Darken the room by pulling the blinds down. Hold an egg before the hole in the center of the box (Fig. 145). If it is a fresh egg you will note the small air-cell at the top end. The yolk appears as a darker shadow, rounded and floating near the center. If it is fertile and has been incubated for five or six days, the embryo will appear somewhat resembling a spider, that is, radiating from the small, tiny embryo will be noted small blood-vessels; whereas, if the

embryo has started to develop and has died, the embryo will be observed, but there will be no radiating blood-vessels. With very little experience one can tell an egg that has begun to form an embryo or chick. You will observe the so-called blood-ring. All eggs not fertile may be removed from the hen or incubator and are fit for human food, or they can be saved and cooked and fed the baby chicks for the first three or four days. (See chapter on Feeding.)

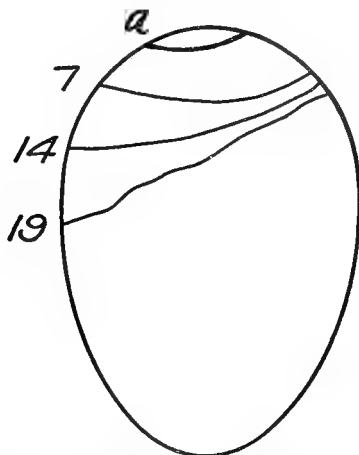

FIG. 146.—The air-cells of an egg at different stages of chick development: *a*, Size of air-cell in the fresh egg; 7, size of air-cell after seven days' incubation; 14, size of air-cell after fourteen days' incubation; 19, size of air-cell after nineteen days' incubation.

A second candling should be made at the end of 14 days, at which time all eggs containing dead germs should be removed. In the recandling the air cells of eggs with dead germs will be cloudy, while those with live germs will be clear.

A piece of black cardboard may be used as an egg tester. Cut an oval hole in the center and in a dark room hold the egg to the hole and the apparatus between you and the light.

Supply each hen with fifteen eggs that have shown evidence of containing live embryos, and if you have one hen without eggs give her fifteen fresh eggs. A good way to care for the hen

and her brood is by making a combination sitting and brooding coop with yard and extension yard, as follows:

Make a box 2 feet square, providing four holes in each side with a 1-inch brace and bit. The holes must be near the top, and will give the hen ventilation and yet no draft on her. Make the front end from 4 to 6 inches higher than the back

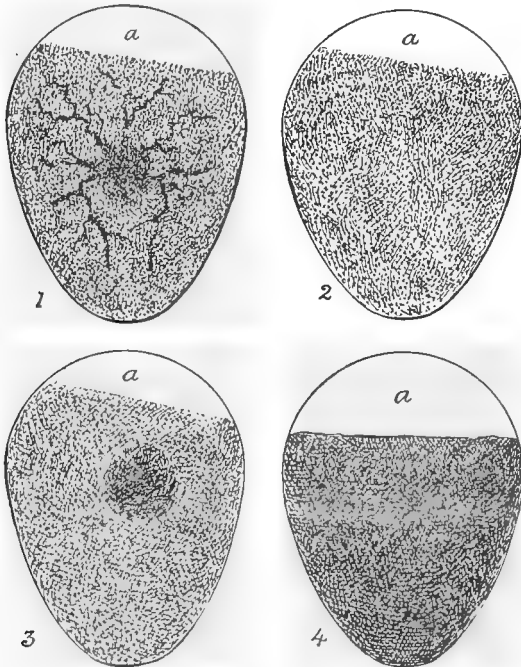

FIG. 147.—1, Embryo five days old. Note the germ and blood-vessels extending from it: *a*, The air-cell. 2, An infertile egg: *a*, the air-cell. 3, *b*, A dead germ about the fifth to seventh day. 4, Embryo about the fifteenth day: *a*, the enlarged air-cell.

and place a shed roof on it. Make an opening in the front 12 inches high and 8 inches wide, and the door so that it can be closed at night to keep out skunks, weasels, and other nocturnal enemies. In warm weather the door should be constructed of netting to give sufficient ventilation. Make a yard as wide

as the house and extend the yard out 3 feet. This can be made out of slats placed 2 inches apart. Make a cover for the top so as to protect the hen and chicks from rain and the hot sun's rays; boards, canvas, or burlap may be used. From this run an extension yard can be made 3 feet long, and so constructed

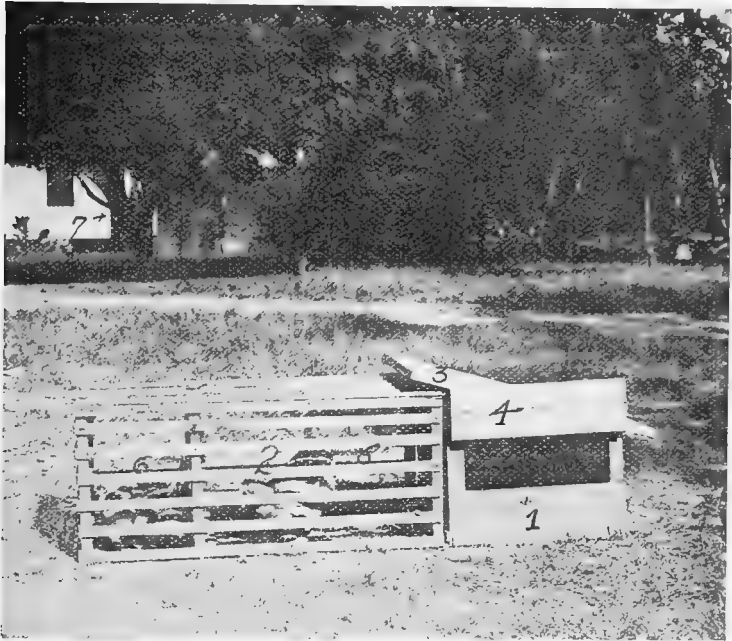

FIG. 148.—A combination sitting and brooding coop. 1, Side view of the coop; 2, the extension run; 3, the roof; 4, the door to the coop; 5, the compartment for the hen; 6, the compartment in which to feed the chicks; 7, shade tree necessary in chick raising. See page 412 for construction.

that the chicks can be fed in this extension and yet the mother or other birds cannot molest them. There is a slatted partition placed between the first and second runs.

Continued damp rainy weather when the ground becomes thoroughly saturated with water makes unfavorable conditions for the young chicks.

The hen usually weans her young when they are six or eight

weeks old. At this time instead of clucking to them she picks at them whenever they come near her.

Cockerels should be separated from the pullets as soon as the sexes can be determined which is at about ten or twelve weeks of age.

When wishing to sit the hen prepare a nest, as indicated before. Dust the hen thoroughly with insect powder, and when through hatching clean out the nest-box, disinfect the box with a 1 to 2 per cent. creolin, or other equally good disin-



FIG. 149.—A portable colony house for the youngsters.

fectant; again dust the hen with insect powder and let her brood her chicks in the box.

If the sitting hen is quiet during hatching leave the chicks under her, as artificial heat is not likely to perfectly take the place of the heat from the body of the mother.

As soon as hatching is over and the brood and hen are removed to comfortable quarters the hen should be properly fed and watered, since she has in all probability eaten very little during the last two or three days. This feed may consist of wet bran mash, or corn, oats, and wheat. The little chicks may be fed later since they should not be fed till they are three days old.

The hen should be confined in the enclosure until the chicks are ready to be weaned.

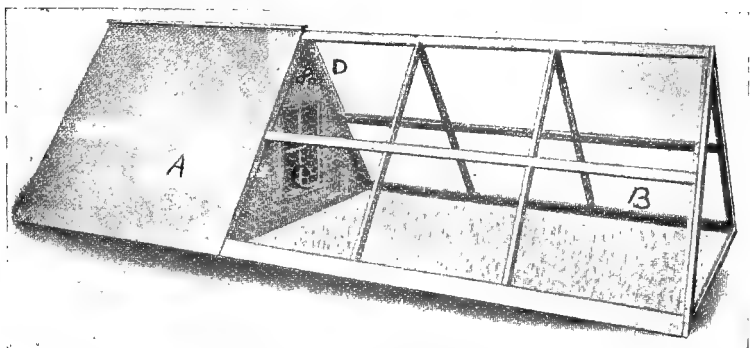

FIG. 150.—A cheap and convenient boys and girls poultry club house and run for sitting and brooding: *A*, The house; *B*, the wire-netting run; *C*, the door to the coop; *D*, the ventilating holes.

From this enclosure the chicks can go a short distance and catch bugs and other insects, which furnishes them with much



FIG. 151.—A series of coops and runs in an orchard where they are properly protected from the hot sun's rays by the shade.

animal food necessary for growth and development, besides ridding the premises of enemies of vegetation. Under these

conditions the chicks will not wander too far and will return again. If the hen is allowed to run on free range, she will take her flock long distances, using no judgment or discretion. The weaker ones will fall behind, and if the weather is cold, or grass and weeds are covered with dew or rain water, the chicks become wet, and if the weather is cold they will become chilled, which means that they are likely to become sick, especially attacked by bowel derangement, and die. The death-rate under these conditions is much higher than when the hen is kept confined.

The house and run being movable should be removed to new quarters once or twice a week. This is advisable from a sanitary standpoint, as the ground close around soon becomes polluted.

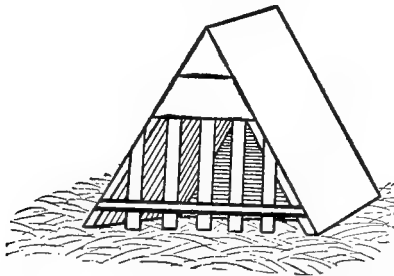

FIG. 152.—A cheap and convenient A-house for a hen and her brood.

In case it is not the desire to sit a hen do not mistreat her, as it is perfectly natural for her to want to brood; it is a part of the laws of nature and follows with birds in their cycle of reproduction. The sitting hen can be easily dissuaded from her notion to sit. Make a broody coop. This coop should be about 2 feet square and the top, bottom, and sides made of plaster lath. The coop can be left out in the open, when finding it impossible to sit the hen will soon give it up. While she is confined, feed and water her so that she will soon commence laying again. She should have an allowance of cut sprouted oats in her feed. If properly cared for, the ovary will begin ovulation again in from ten days to two weeks.

To protect chicks from hawks and rats make wire netting runs 18 inches high and 4 feet by 12 feet and allow

the chicks to run in this netting covered run during the day. At night a frame covered with $\frac{1}{2}$ inch sand screen is placed tightly against the front of the open coop to keep out the rats and other nocturnal enemies.

THE SMALL INCUBATOR

In hatching eggs with an incubator the first cost—that is, the cost of the machine—is between ten and fifteen cents per egg capacity. A machine holding 100 eggs should not cost more than ten dollars.

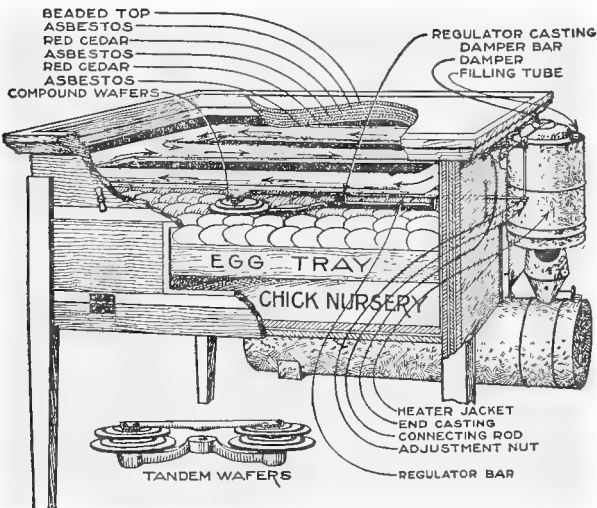

FIG. 153.—A diagram showing the parts of a small incubator. (St. Helms. Inc. Co.)

The cost of operating a 100-egg incubator twenty-one days, using kerosene at twelve cents per gallon, will be about twenty-five cents, or, in other words, it will require about 2 gallons.

It costs from ten to fifteen cents a month to feed a hen. The cost of feeding six hens, which would equal in capacity the 100-egg incubator three weeks, will be about fifty cents.

The labor of caring for an incubator is no more than caring for the six hens.

An incubator consists of three essential parts—namely, an insulated and ventilated box—the body—a heater, and a regulating device.

The body of the machine is supported by legs. The heating device is attached to the side of the body, except in those operated by electricity or by a stove.

The body is provided with three chambers—namely, an upper, middle, and a lower (Fig. 153).

The upper chamber is the heating chamber, and is separated from the egg chamber by a diaphragm in those heated by diffusion or by a radiating surface in those heated by radiation.

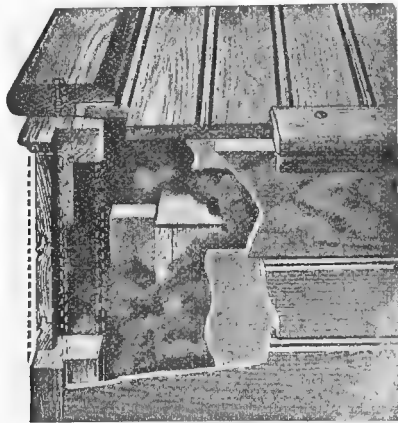

FIG. 154.—A view showing insulation of a small incubator.

The diaphragm is usually of cheese cloth. After each hatch this cloth should be thoroughly dusted to keep the pores of the cloth open.

In single-tray incubators, the tray should be turned end for end. In two-tray incubators the trays should be turned end for end and trays exchanged each day.

In the hot-water system the chamber is occupied by pipes. These pipes are not separated from the egg chamber.

The eggs occupy the middle or egg chamber.

The lower chamber is provided with a canvas-covered tray, and is called a nursery chamber. A glass door is placed before

this chamber and, as the chicks are attracted by light, they come to the edge and fall into the nursery tray. This arrangement is to relieve the congestion of the egg-tray during hatching.

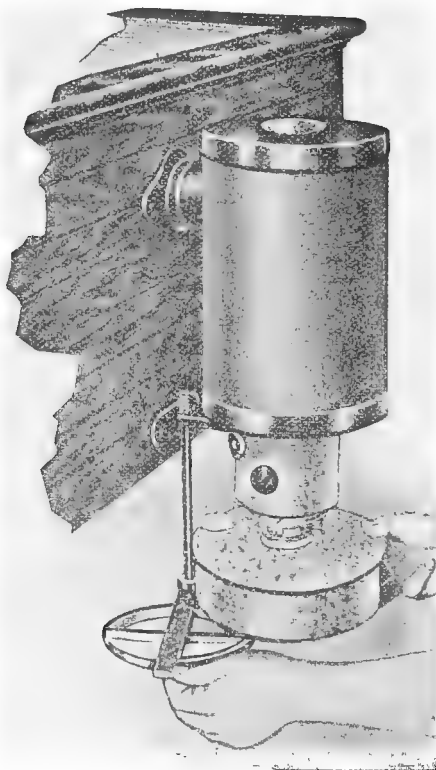

FIG. 155.—Showing method of handling lamp (Essex).

The regulating device is so constructed that a fairly even temperature is maintained in the egg chamber (Figs. 153–156).

The incubator has a ventilator at the bottom to allow the escape of the carbon dioxide laden air, this should be kept open at all times.

The thermoregulator (Fig. 157) consists of a thermostat

(*b*) joined to a damper arm (*k*) at the pivot casting (*g*). The connecting rod passes through a connecting tube (*d*), which supports the thermostat at its lower end by a casting (*e*)

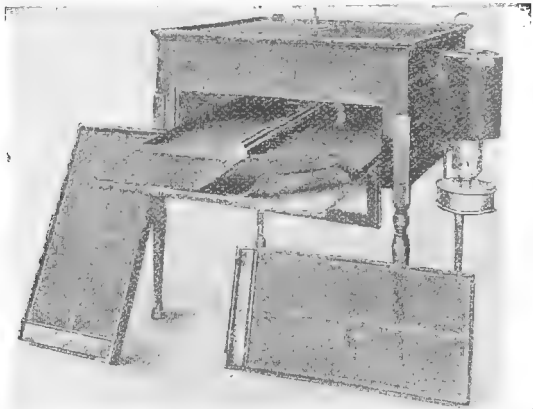

FIG. 156. An incubator ready for use. Showing egg-tray, nursery tray, lamp, and thermoregulator.

which lies under the casting (*f*). The connecting rod must be straight and pass through it without touching it. This makes sure there is no friction for the thermostat to overcome. If the

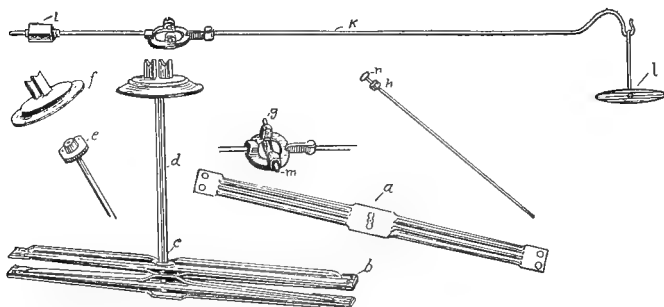

FIG. 157.—Various parts of a thermostat. (See body of text for description.)

connecting rod becomes kinked it is better to obtain a new one. When the thermostat expands it pulls down the connecting rod, and a thumb-nut (*h*) pulls on the pivot (*g*) which is situated

just back of a line joining the knife-edge bearings (*m*), which rests on the two projections of the base casting (*f*) and which acts as fulcrums. The damper arm (*k*) acts as a reverse lever, and a little pull at *g* is transformed into a considerable raising of the damper disk (*l*). The damper arm is balanced by a counterbalance weight (*j*), and the damper will close of its own accord unless restrained by a pull from the thermostat.

For oil burning incubators, use good oil. Clean and fill the lamp once daily, trimming the wick by scraping the charred portion off with a knife or square-edged nail, or by cutting the wick with scissors. The burners should be kept free from

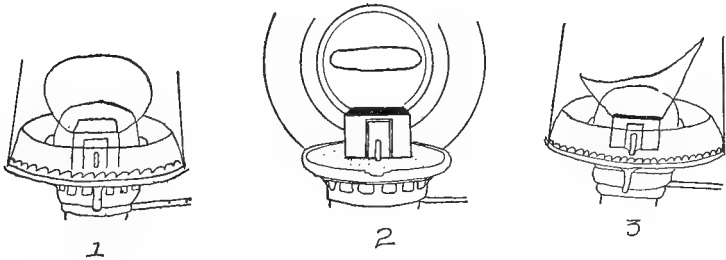

FIG. 158.—1, The flame shaped as here illustrated will give the greatest possible amount of heat and may be turned quite high without danger of smoking. To secure it trim the wick as illustrated in 2. 2, The corners of the wick must be rounded off as here indicated to get the ideal flame as shown in 1. 3, If the corners of the lamp wick are not properly rounded off the flame will be sharp-cornered, will smoke readily, form dangerous soot and the lamp will supply comparatively little heat.

dirt and thoroughly cleaned by boiling after each hatch. Turn the eggs before caring for the lamp, so there will be no chance of getting oil on the eggs and thus make possible the closing of the shell's pores with oil. The flame is apt to increase in size after lighting, so that it is advisable to return about half an hour after tending to the lamp to see that the flame is all right.

The eggs are turned daily in the egg-trays during incubation, except the last two days, when the incubator is not opened.

Successful incubation depends on the faithful carrying out of the four great principles—namely, proper ventilation, proper

moisture, proper temperature, and proper position. The eggs should lay on their sides.

To successfully operate an incubator it must be in a room not subject to sudden changes in temperature; an abundance of fresh air with ventilation at the top and bottom of the room. The humidity should be high, and the sun's rays must not strike the incubator at any time during the day.

The incubator must be level, lest you have hot corners.

A cellar is a good place, provided it is dry and clean and free from foul gases.

The eggs in the incubator need not be turned after the eighteenth day, and the incubator should be kept closed. As soon as the chicks begin to pip the moisture pans should be removed and the aperture for the chicks to drop through opened. The incubator should then be closed and kept closed till the hatch is over. The struggling chicks sometimes raise the temperature of the incubator beyond the ability of the regulator to control it, so that it is necessary to keep close watch of the thermometer. The thermometer must not be allowed to run over 105° F.

Leave the chicks in the incubator at least seventy-two hours after the hatch is over. This will allow the absorption of the yolk left in the abdominal cavity of the chick at the time of hatching.

If the baby chicks are taken off and fed too soon, and they gorge their intestines before the yolk is practically all absorbed, there may be an interference with absorption of this yolk by pressure on the absorbing vessels and digestive complications result.

A woolen-lined, hooded basket should be used in removing the chicks from the incubator to the brooder. A cold wind striking them at this time may result fatal to many of the baby chicks.

Poor hatches may be due to too uneven a temperature. The eggs in the incubator not being turned for the last three days allows the chick to work around and be head up. All chicks should be out of the shell in eighteen hours after hatching begins. Often the chick can be aided by turning with "pipped" side up and by cracking the shell around the circum-

ference. If the membrane becomes too dry a few drops of warm water may be sprinkled on the membrane.

Eggs left standing on the end instead of the side may result in cripples being developed.

Chicks dead in the shell may also be due to low vitality of the eggs, caused by being kept too long before sitting, or at improper temperatures, from parents being too old, from parents being too young, from inbred parents, the male mated to too many females, the flock poorly fed, eggs overheated, the eggs chilled too much during incubation, too much moisture or insufficient ventilation, or parents not receiving sufficient exercise or green feed.

If the air be too moist there may not be sufficient evaporation from the egg. On the other hand, if the air be too dry, the evaporation may be too great and the membrane becomes too dry and even leather-like and the chick unable to break through.

Duck eggs require to be incubated at $\frac{1}{2}^{\circ}$ to 1° F. lower temperature than hens' eggs.

Turkey eggs can be successfully hatched in the incubator and the poults raised by aid of the brooder, as in chicks.

Barrels or large boxes may be placed around in rather secluded places for the turkey hens to lay in. These barrels or boxes must be clean and nests made of clean straw.

Some breeders yard their turkeys till after 4 o'clock, which compel them to lay in nests prepared for them.

The turkey hen begins laying at about ten months of age.

Turkeys usually commence laying in March, and lay fifteen to twenty eggs before becoming broody. If the broodiness is broken up she will begin laying again in about ten days.

One male is sufficient for ten females.

Barrels should be placed on their sides and straw nests made in them. These barrels should be placed in out-of-the-way places. The same person should always attend the sitting turkeys, as they do not like to be disturbed, and may desert their nests or break some of the eggs. One good-sized female should cover twenty-five eggs.

It is often found necessary to remove the tom from the sitting turkey hen or the brooding young poults, and, in fact, often

the male may interfere with the hen laying and even drive her away from the nest. Poults only cry when hungry.

Broodiness has been bred out of some kinds of birds, as the Mediterranean breed of chickens, especially the Leghorns, and in some kinds of ducks, as the Pekin.

Duck eggs may be placed in an incubator or under hens. A hen can cover about ten duck eggs. Duck eggs do not keep as well as hens' eggs.

Geese.—There should be as many nests as there are geese. When nests are located outside of the building, barrels will be found to make very good nests.

Geese lay early in the morning. If they lay in cold, freezing weather, close watch must be kept on them to gather the eggs before they have time to become too much chilled. A goose lays from fifteen to twenty eggs before becoming broody. Usually the first eggs are set under hens. If the goose is not allowed to set, but placed in a crate till she ceases to be broody, she will soon begin to lay again. It is well to set the goose the second time she becomes broody, as she may not lay more than two batches in the season. Occasionally one will find a goose who will lay the entire season and not become broody.

A goose should be set in the nest where she has been laying, and if she becomes cross should be left alone.

The goose eggs hatch very slowly, requiring the greater part of two days after beginning to pip the egg before the gosling emerges.

The goslings should be left in the nest till strong enough to run around.

A goose laying in a nest made in a pile of straw has a tendency to cover the eggs.

Goslings should not be hatched on the farm till after the grass is green.

Incubators do not prove very satisfactory for goose-egg hatching, and it is better to hatch the goose eggs by the hen or allow the geese to set and brood them.

A goose will cover about ten eggs, and hens of the American breeds, as Rocks or Reds, in warm weather will cover five or six and in cold weather only three or four.

If hatched by the hen, the first gosling must be taken away as soon as hatched and wrapped in woolen cloth. If this is not done, the hen or goose may leave her nest before hatching is over.

They should be kept confined with the mother till they are about five days old.

The Electrobator.—Electrical incubators and brooders have been placed on the market. The same principal of construction is used as in those burning gas, coal, or oil. They are so constructed that they may be attached to any electric distributing lines commonly used in dwelling houses. They may be operated in a cellar or in some room in the house. The room in which they are operated should be as near an even temperature as possible.

CHAPTER XXIII

THE MAMMOTH INCUBATOR AND BROODER

WITH the increased interest in poultry production in the United States, there comes provisions for hatching chicks in large quantities.

With the development of the times and modernization of all things, there is a tendency to concentrate work and proceed along economic lines.

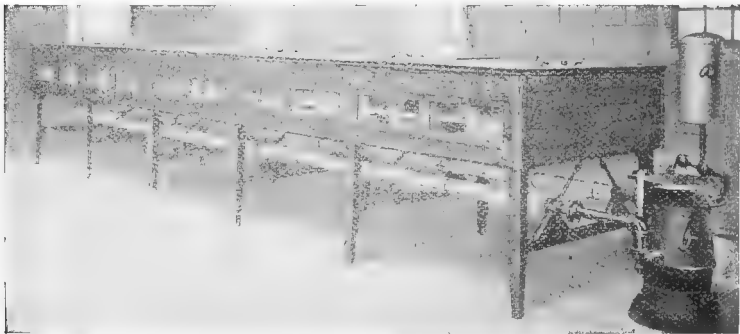

FIG. 159.—A view of a giant incubator: *a*, Expansion tank; *b*, the coal heater.

There has grown up in many localities custom hatching and a baby chick trade. To furnish chicks in large quantities a correspondingly increase in capacity for hatching must be provided, hence the development of the large incubator, which, on account of its large size, has been called the giant incubator.

The fact that when the chick is hatched the abdominal cavity contains a part of the yolk-sac unabsorbed makes it possible to ship the baby chicks long distances. These boxes are provided with proper ventilation with no draft.

Centuries ago the Egyptians and others hatched chicks in large quantities in large ovens in which a fire was kept kindled.

The Chinese buried the eggs deep in manure to attain the proper amount of heat for incubation.

The giant incubator is constructed in sections, each section being provided with four trays, of about 150 eggs' capacity.

Each setting of eggs has its own automatic regulator, which assures a steady and even temperature, thus making it possible

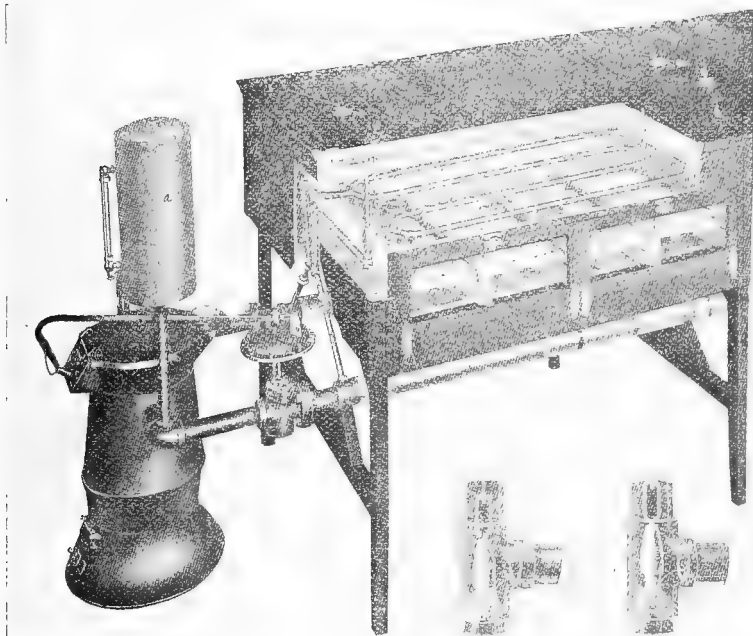

FIG. 160.—A view showing heating arrangement of one compartment (Candee).

to have settings at different stages of chick development (Figs. 159 and 160).

Incubation is primarily a heat problem. In solving it the main consideration in mammoth incubators is that each different compartment containing eggs be held at the exact degree of heat required, and yet safely protected every instant during the incubating period regardless of the operator or weather.

“Safety first” is of the greatest importance, and when

applied to incubation it can only be secured by automatic protection of the eggs against overheating.

Each egg chamber may be considered a separate incubator, with its own heating system. Each sitting of eggs is started whenever an egg chamber is empty and it receives only the heat it needs, and securing it directly from the main supply without having to pass through any other egg chamber in such systems as used by the Candee, where by a set screw each chamber is regulated to its desired temperature. In some other makes the pipes run directly through all of the chambers, and



FIG. 161.—View of the egg and nursery trays in a small giant incubator.

a special regulating device is constructed on each chamber to properly regulate the temperature.

The mammoth incubator is made up of a series of units or compartments, with one common source of heat—namely, a coal-burning hot-water heater.

In Fig. 160 the top of one of the compartments is cut away to show the automatic heating system and the coil of pipes from which heat is radiated. The illustration shows the heater with its automatic draft regulator (*c*) and the large covered supply pipes (*d*) located under the machine, and a small supply pipe (*e*) for a 300-egg compartment. In the smaller pipes the direction of the course of the warm water is indicated by the

arrows. In the compartment will be noted the thermostat or thermoregulator, just above the eggs (*f*). Its connection with the compartment valve is easily traced. In Fig. 160 *g* and *h* shows these valves in two operating positions. When the thermostat opens the valve wide there is a free flow of heated water into the pipes, and when the compartment becomes too warm it gradually closes down, thus gradually regulating the amount of water that passes into the pipes and thus maintains an even temperature. Other types do not regulate the chambers by a hot-water valve, but instead provide a thermo-regulator, as shown on the smaller type machine (Fig. 156),

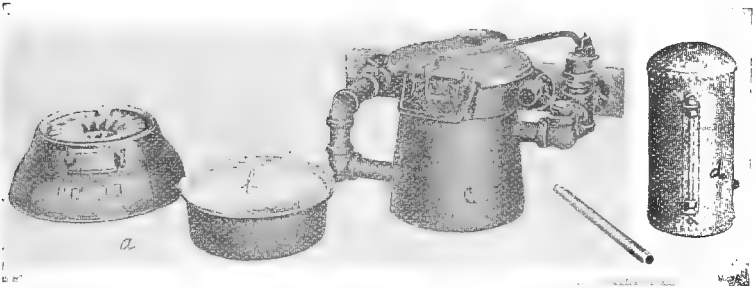

FIG. 162.—The parts of a heater in a giant incubator: *a*, The base and grate; *b*, the brick ring; *c*, heater, water-pot, and top; *d*, pipe tank and gauge-glass.

which, as the chamber becomes too warm, opens up a circular opening at the top of the chamber and allows the escape of the surplus heat.

The mammoth incubator has trays opening on both sides, thus giving right- and left-hand compartments.

It will be noted that while all of the compartments in Figs. 159 and 160 are connected with the main water-supply, because of the compartment valves there are two water circulations. First, there is a continuous circulation in the main supply, and, second, an intermittent circulation in each compartment radiator for each sitting of eggs.

The first circulation is in the water-jacket around the heater fire (Fig. 159, *b*), from which the hot water flows through the right hand in (Fig. 160) a large covered pipe, carrying the heat-

supply under all the sections and then across under the last section to the left side of the machine, and is the common return pipe from the compartment radiators. This main supply can be piped in any direction, and there the sections can be set in a continuous row, or to skip posts or a double row, and in various other shapes.

As stated before, in other type incubators there is but one water-supply, which has two thermoregulators, the second thermoregulator controlling the heat of the chamber by allowing heated air to escape from a circular opening in the top of the chamber and cool air to rush in to reduce the temperature to the proper degree.

In some makes of incubators the supply pipes, as well as the return pipes, are on the inside of the compartments.

All of the hot water, after leaving the heater, flows around the bottom of the heater regulator, so that the regulator is constantly affected by the temperature of the water, and it in turn opens or closes the heater drafts, and thus automatically controls the fire brought about by the expansion or contraction of the mass of water contained in the pipes as a result of the heat or cold.

In those provided with a double system, as in Fig. 160, the hot water rises, and the heating system is so arranged that were there no compartment valves the water would be circulating through each compartment radiator as well as the main supply. It is necessary that each sitting of eggs have the exact degree of heat required, according to the length of time incubation has been in progress, and the compartment thermostats attend to that for the operator. The thermoregulators admit the proper amount of water to maintain the temperature needed in that compartment. The hot water is always ready to pass the compartment valve and flow through the radiator and return directly in the common return pipe to the heater to be reheated.

It will be noted that the thermostat is directly above the egg-trays. It is the desire at all times to know the temperature at the top level of the eggs, and the best methods of handling the thermometer is by laying the thermometer bulb on the top of a fertile egg. It is not desirable to lay the bulb on the top of an infertile egg or one containing a dead embryo, as the

dead embryo or egg, in which there is no life, is much cooler, thus the exact temperature of the incubating eggs are not recorded. Some makers now construct the thermometers with the bulb exposed so that it is easy to bring the bulb in direct contact with the eggs.

The automatic regulation is necessary to successfully meet ordinary conditions. In the early spring the weather fluctuates from extreme cold spells to very warm weather, which often makes changes in the temperature of 15 to 20 degrees in a few hours. Frequent high winds come up in a few minutes, and with the wide variations it is practically impossible to keep anything like a uniform cellar temperature.

Having a thermostat just above the eggs it expands with heat and contracts with cold, thus accurately controlling the heat. Thus, if too much heat accumulates in the egg chamber the ventilator is opened and the excess is allowed to radiate off.

The exterior of the machines is constructed of wood, as chestnut, walnut, or oak. The material should be tongued and grooved, and the parts insulated to prevent any cracks admitting a draft of cold air directly upon the eggs.

The stove or heater is usually constructed with a round base which sets squarely on the floor. The ash doors and drafts fit tight, so that when closed there is no air admitted. The grates are usually of the sliding and slicing type, which permits of the ready removal of clinkers. The heater pot and water cylinder should be cast in one piece. There should be ample water capacity to ensure quick circulation and a steady flow of water.

A draft regulator is arranged in the heater top. This consists of a check door in front and a griddle seating directly on the top of the water jacket. With the front door closed the griddle is raised, allowing the fire to burn faster. As the griddle seats the front door opens.

When the front door of the stove is opened, air from the room is drawn over the top and up the chimney, indirectly assisting in the ventilation of the cellar.

In the heater pipes the same water is used over and over again.

When desired electric lights are provided, drawing their current from dry-cell batteries. Small bulbs are attached

inside the egg chamber, and by pressing a button above the door there is an illumination, making thermometer reading easy.

Ventilation of the compartments is made through holes in the bottom.

In egg development there is given off from the eggs carbon dioxide. As carbon dioxide is heavier than air it settles to the bottom, and with the ventilation in the bottom of the compartment the chamber should keep from having an excess of this gas.

The first principle in artificial incubation is a steady, even, overhead heat, and no greater heat surrounding the eggs than the hen gives.

Cellar ventilation is essential, so that the air-supply outside the machine is fresh. The eggs need the proper supply of oxygen, and must have taken away the air that has become polluted with CO_2 , as a result of the living processes of the embryo inside the shell.

Proper moisture should be in the air of the egg chamber, and in order that the proper amount be ensured the chamber is usually supplied with a water pan in which water is kept. The proper amount of moisture prevents too rapid evaporation from the egg during incubation.

It is estimated that the minimum space of the incubator cellar should be 2 cubic feet space for each egg-capacity together with a circulation of fresh air. In incubator cellars below the ground air shafts should be extended to the floor. The windows should be on the north and not on the south or west unless protected by shutters. Sun-rays finding their way into the incubator cellar will modify the temperature too much and make the variation between day and night more than can be overcome by the thermoregulators of the incubators. The room temperature should not vary more than 20° F. at the most in twenty-four hours.

Constant Temperature Essential.—For successful incubation there must be a regular and constant temperature, with fresh air and moisture at a definite rate. If it is an air circuit machine and the pipe empties onto a diffusion diaphragm of cheese cloth, this cloth must be kept brushed clean so as to

keep the pores open and allow rapid diffusion. It has been estimated that the required amount of fresh air is one cubic foot per egg per hour. A chamber containing 200 eggs would require 20 cubic feet of air to pass through it per hour. This would be a complete change of all air in the compartment three times during the hour.

The light must be higher at the start to secure the right temperature in the egg chamber. The embryo in the egg respire giving off moisture and CO₂. If the moisture of the chamber is too low the shell membranes become too dry and the chicks have trouble getting out of the shell, or even die in the shell. The humidity must be constant.

The amount of heat needed over any 600 eggs at different cellar temperatures, as given by the Candee Incubator Co., is as follows:

Cellar temperature	Square feet of radiation required to secure 103°
Zero.....	2.94 square feet.
10 above.....	2.655 "
20 ".....	2.151 "
30 ".....	1.702 "
140 ".....	1.29 "
145 ".....	1.072 "
150 ".....	0.858 "
55 ".....	0.642 "
60 ".....	0.429 "

When the cellar temperature rises from 40° to 60° F.—only 20° F.—only one-third as much heat is required; and as the cellar gets warmer, less is required.

The thermometer bulb should be kept at the top of the eggs. Some recent investigational work rather points to the fact that the better hatches are obtained where the temperature is kept during the entire three weeks at 103° F.

Effect of Humidity.—The hygrometer is an instrument with which we can tell just how much moisture there is in a machine. It is found that to obtain the best hatches there should be 60 per cent. moisture in the air that passes through the machine, 55 per cent. the second week, and 50 per cent. tapering down to 45 per cent. by the end of the third week.

¹Normal cellar temperature.

There is a greater loss, with the haphazard methods under which most incubators are run, than where the eggs are placed under hens for hatching.

Extreme dryness and extreme humidity are both detrimental. The range between the temperature of the incubator and that of the room influences the humidity in the egg trays of the machine. The difference of the temperature of the two bodies of air—the one in the machine and that outside—causes a circulation of air through the machine. As the difference in temperature decreases, there is less circulation and higher humidity in the machine. A machine set in a corner where there is dead air will have insufficient circulation of air, and there is likely to be a poor hatch. To maintain a uniform humidity, note must be made of the range of temperature, and the supply of moisture must be governed accordingly. A wet bulb thermometer kept at a temperature of about 88° gives the most favorable results.

Carbon dioxid is given off from the embryo through the egg shell. Atwood has shown that the loss of carbon dioxid during the last five days of incubation is about five-eighths of the total loss of carbon dioxid, twice as much as is given off in the third five days, ten times as much as in the second five days, and almost fifty times as much as in the first five days. In an incubator this carbon dioxid must be kept below 150 parts in 10,000. One hundred fertile eggs will require 165 cubic feet of fresh air to be passed over and around them on the twentieth day to keep the embryos from asphyxiating.

Standardizing the Incubator.—Proper moisture, it is found, will result in as much as 35 per cent. difference in hatching of the eggs; therefore the incubator trays should be standardized by the following rule:

Rate of evaporation depends to a certain extent on amount of ventilation; therefore it will be necessary to observe just how much ventilation you have in applying moisture. The difference between the temperature of the body of air in the room and that of the incubator makes the exchange of air in the incubator possible, and the greater this difference the faster the two bodies of air will exchange.

Calcium salts are absorbed from the shell during the chick's

development. This is made possible by the moisture inside plus CO₂, and the shell thus becomes brittle. Proper moisture and ventilation as well as temperature, it is found, affects even this.

Moisture is to be furnished by sand in the pans, and the amount of moisture to be supplied must be worked out by the following tests. The proper loss of weight of eggs, on an average, should be as follows:

During first	6 days . . .	3.5 to	4.0 per cent. loss.
“ second	6 “	4.0 “	4.5 “
“ third	6 “	4.5 “	5.0 “
	Total	12.0 “	13.5 “

The Hatch.—When conditions are right all chicks should be out of the shell in from twelve to eighteen hours after the first chick frees itself.

Long drawn out hatches indicate that there is something wrong. Slow hatches cause weak chicks and cripples.

The chicks should be kept in the nursery tray three days at a temperature of 98° F. to 100° F. During this time the chicks do not need to be fed or watered.

Start the heat in the brooder twenty-four hours before placing the baby chicks in it so as to ensure proper regulation of the temperature.

The temperature of the hover should be 95° F. to 100° F. when chicks are placed under it. The chicks occupying the hover space will raise the temperature 3° to 5° F. The third week the temperature may be dropped to 90° F. and after the fourth week 75° F.

The baby chicks may be placed in the brooder at the end of the third day and be given sour milk the first day and two feeds on the following day, and on the sixth day on full feed. The first five days the feed may consist of

Stale bread	2 parts.
Rolled oats	2 “
Hard boiled egg	1 part.
Mix with sour milk. Sprinkle with sharp grit.	

(See chapter on feeding.)

It is generally conceded that hot water is the better heat for incubating and brooding. It does not consume the oxygen needed by the developing embryo. It is a mild heat that diffuses a gentle warmth.

It is estimated that an 1800-egg-capacity incubator can be operated five weeks at a cost of only \$3.15 when coal is \$7.00 a ton. The time for installation is estimated at one day, and the time consumed in running it as two hours a day. It is finally estimated to be 25 per cent. cheaper than the oil method, as used in small machines.

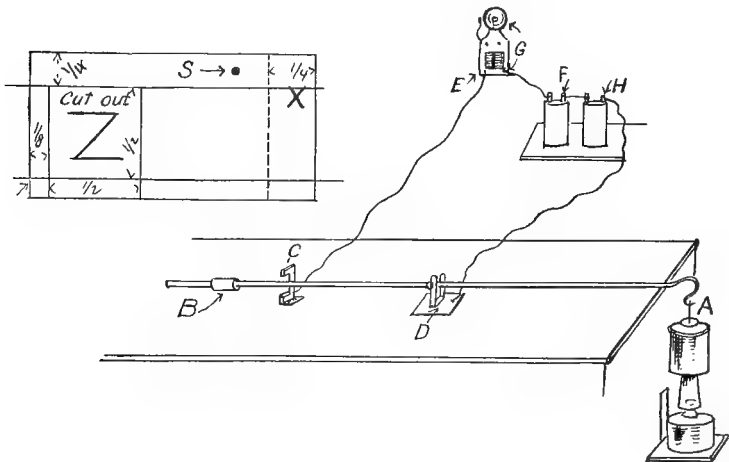

FIG. 163. An electric alarm for an incubator.

An Electric Alarm for an Incubator.—Mr. Walker has designed a simple but accurate device to give an alarm when the temperature goes too high in the incubator. If the incubator is in the basement and you are sleeping, and the temperature goes to 110° F., you have an alarm arrangement to save your sitting.

By referring to Fig. 163 it will be seen that the device consists of an electric door-bell outfit, using the thermostat as a switch. Take a strip of copper and cut it into shape and tack it to the incubator; a strip of copper $\frac{3}{4}$ -inch wide and 2 inches

long is bent in X squares; then cut out Z $\frac{1}{8}$ -inch from the top end and $\frac{1}{2}$ by $1\frac{1}{2}$ inch and punch holes at S for wire.

Overheating.—A great danger in artificial incubation is overheating the eggs, which is impossible to happen with the hen. Overheating is more serious than the same degree of underheating. Eggs raised to a temperature of 105° F., and held at that temperature for any length of time, is dangerous, and the embryo may die when the temperature reaches 107° F. The proper hatching temperature is 103° F. The temperature may be allowed to fall to 99° F. for considerable time without apparently destroying the embryo. This delays the hatching a few hours.

There are not so many eggs chilled or broken in incubator hatching as hatching by the hen.

An incubator is desirable on the farm where 200 or more chicks are to be raised. Hens are rather uncertain; many are poor sitters, some desert the nests, and a late spring means late sitting, making late hatching inevitable and undesirable.

Heavy breeds should be hatched in February, or March at the latest, and the light breeds the first week in April. Chicks hatched too late suffer from the heat and do not mature early, and without development there is no proper weight, and weight is needed when making our selection for breeders and layers for the fall and winter and spring work.

The hatching powers of the incubator are probably not quite so great as those of the hen.

All incubators before being used should be thoroughly disinfected by scrubbing with a 1:500 solution of formaldehyd solution, and both egg and nursery trays should be disinfected in a like manner between each sitting.

CHAPTER XXIV

BROODING

Brooding may be done by one of two means: First, by natural brooding or by the hen; second, by artificial means by either cold or heated brooders. Heated brooders may be run by oil, coal, gasoline, gas, or electricity. Hard nut coal is used in coal burning hovers and incubators.

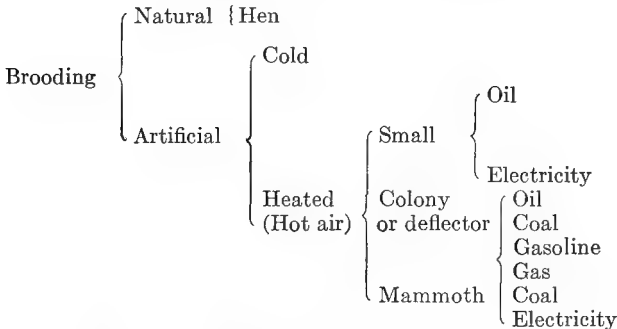

In artificial brooding the following conditions must be taken under consideration: A compartment in which the temperature is under control. Dryness and a constant supply of fresh air are essential. A brooder may be of two kinds—that is, an indoor brooder or one kept inside a building, providing a run, and the outdoor brooder. The outdoor brooder is provided with two compartments, one compartment having a cooler temperature than the other, to which the chicks may escape for food, exercise, and a sun-bath. Sufficient space and sunlight must be provided. Safety from fire and protection from enemies, as cats, hawks, crows, and skunks.

Frequent disinfection of the brooder and feeding and watering utensils are necessary. The second compartment of the outdoor brooder is the warm-air compartment, provided with

a hover, which is supplied heat by means of a heating apparatus, with either hot air or hot water. The hover should be

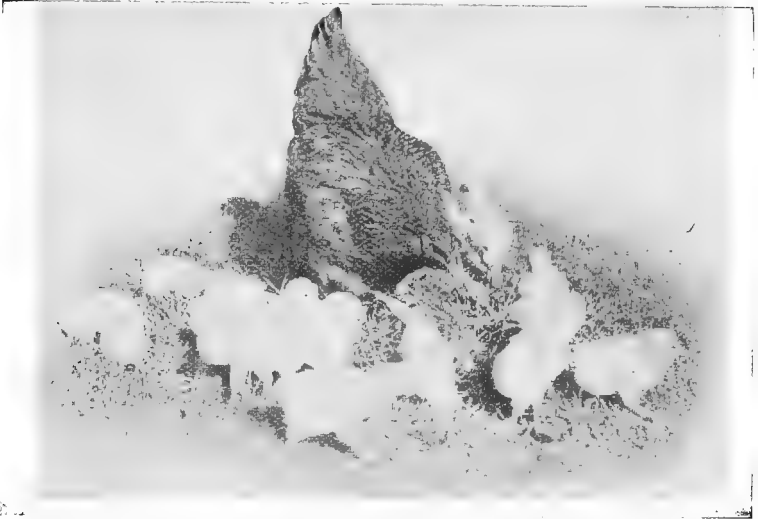

FIG. 164.—The mother and her brood. (Iowa Experiment Station.)

provided with a thermoregulator. It is essential to provide sufficient ventilation to allow fresh air, so the chicks have the

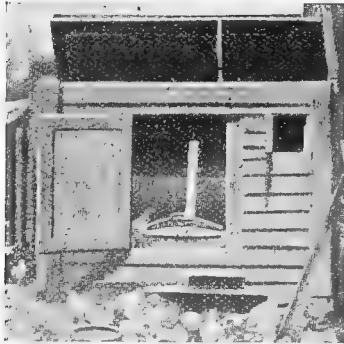

FIG. 165.—A colony brooder house. The hover is in the center of the house.

proper amount of oxygen and to allow the escape of polluted air containing carbon dioxide given off from the body of the

chicks. The ventilator must be so constructed that there will not be a draft on the birds.

The most common cause of the small oil hovers catching on fire are: soot collecting in the chimney, holes in the burner becoming clogged, filling the lamp too full. It is therefore best to keep chimney clean and holes in burner open, to fill only two-thirds full, to keep the wick long enough, to trim properly by cutting the top square and clipping the corners so there will be a round flame or to rake off with a match the charred wick.

Guard against the accumulation of oil gas in the upper chamber of the brooders. After a certain amount of this gas has accumulated, it flashes, and the whole interior of the brooder catches fire.

There is also a possibility that when the wick burner gets too hot the wick will siphon more oil than the flame can consume and ignition takes place and the hover catches on fire. There have been constructed and put into use wickless brooders which eliminate this danger.

Filth of all kinds must be guarded against. Filth harbors harmful germs, and in many instances germs of contagious diseases. The location of the brooder should be dry.

The indoor brooder should be located in a building that is dry, has good ventilation, and can be easily cleaned and disinfected. There must be protection against enemies, as cats and rats, and a scratching room must be provided when the chicks are old enough to scratch for their feed.

As stated before, the outdoor brooder is provided with a hover, in some of which there is provided a radiator. This radiator in some instances is a hot-water coil, while in others it is a metal drum in which a lamp is located. When a water-coil is used the system is similar in structure to that of the incubator. It is recommended by some to have an inch of sand sprinkled on the floor, in the second compartment, in which they are fed and receive a sun-bath through a glass door. In nature a hen in brooding her chicks sits on the ground. To mimic the hen the brooder must supply top heat. There must be ventilation to carry off the respired air and supply them fresh air, but there must not be any draft on the birds. The sand placed on the floor in a way mimics nature and is

calculated to prevent them from becoming weak-legged. In placing sand it will be necessary to see that the baby chicks when first placed in such quarters do not gorge themselves with sand. When the baby chicks are taken from the incubator they will fill up on chaff, sticks, and sand if not looked after carefully. Therefore, as soon as they are placed on the floor have feed there for them so they can fill their crops, and thus prevent impaction and death of some of them from that cause. There should be no trouble after they have their crops full if they are properly fed. Do not allow the chicks to become chilled or exhausted by following a hen, as such treatment will be disastrous, for chilling causes diarrhea and pneumonia and exhaustion saps them of their vitality and retards their



FIG. 166. —An out-door brooder: A, The lamp compartment; B, the hover; C, the feed room and sun-bath parlor.

growth. Chicks must be kept warm at all times. If they stand around and peep you know they are cold and that they need be placed under the hover.

All incubators, brooders, drinking-troughs, and fountains should be thoroughly disinfected before being used a second time.

If chicks die of a contagious disease, as white diarrhea, the hover and room must be thoroughly and frequently disinfected. Scrub with a 1:400 solution of formalin. A small broom with a handle will be found convenient for this disinfection work. A force spray-pump can also be used to advantage.

Depraved appetite, as toe picking, is one of the vices of brooder-raised chicks. Particularly is this true if the birds are placed in crowded quarters.



FIG. 167. —Colony brooder houses, using forest trees as shade.



FIG. 168.—Improvised shade as used by the North Carolina Experiment Station. Birds must be protected from the hot rays of the sun in summer time.

An abundance of animal food may prevent the toe picking. When the chick once gets a taste of blood he becomes a cannibal and the vice is difficult to check. By continually picking

there will result a loss of considerable blood, and as a loss of blood means a loss of proteins from the body it can be readily seen that it is a condition to be avoided. When the vice starts, remove the chicks with bleeding toes and give the flock more room, and if the animal feed has not been included in their feed, supply it. Give them scratch feed in litter and make them work.

In those with a depraved appetite often one finds the chicks fill their crops to distention with sand and other undigestible material, as chaff. Many of these birds then suffer from impaction and may die. If they pick at the curtain the oil-cloth may be replaced with canvas.

In the hot summer time it is essential that the young birds be provided with sufficient shade. An orchard makes an excellent place in which to raise poultry. If it is the intention to raise poultry on the semi-intensive plan it is well to plant the trees about 45 feet apart, which makes it possible to alternate crops and poultry, and by having twice as much orchard space as needed one plot can be farmed in corn, wheat, or oats for poultry feed and, at the same time, the fruit trees and nut trees, as pecans, will also bear a crop. This tillage prevents the soil from becoming germ-laden and foul, a condition dangerous to the health of the birds.

PLANS FOR A HOME-MADE BROODER

Figure 169 illustrates a home-made brooder. It is 15 inches deep, 24 inches wide, and 48 inches long. When the top and bottoms are added the height is about 17 inches.

The following material is required: 150 lineal feet of matched flooring, with $3\frac{1}{2}$ -inch surface and about 40 lineal feet of $\frac{3}{4} \times 1\frac{1}{2}$ -inch strips. Buy both the flooring and the strips in either 12, 14, or 16 feet lengths. Use 4 and 8 size finishing nails. One pound of sheet asbestos, one piece of standpipe tin, about 25 inches square; two pair of small hinges, one piece of $\frac{1}{4}$ -inch mesh wire cloth, about 6×12 inch size. One lamp front and chimneyless burner.

First, make the ends 15 inches high by 24 inches long. Nail the end or cross-pieces on the outside, and allow same to extend

over the edge enough to cover the ends of the front and back, as shown in the drawing. Then build the sides onto the ends and underneath nail on the bottom floor.

Next build a partition in the middle, the height of the brooder inside. Place the cross-pieces of the partition on the left side, and around the inside of each department tack a narrow strip $7\frac{1}{2}$ inches from the top. Upon this lay the middle floor on the left side of the partition. On the right side make a removable floor, in the center of which cut a 3-inch hole.

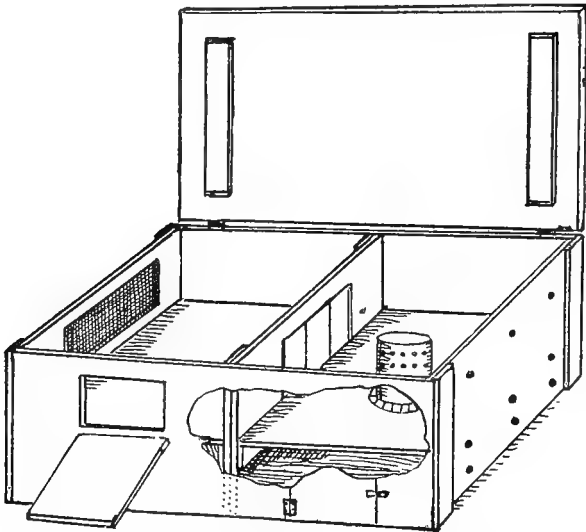

FIG. 169.—A home-made brooder. (See description in text.)

Tack the crosspieces underneath the floor, and cut about 2 inches short and space about 1 inch from the top edge. Melt off the ragged edge of a large tin can (as a tomato can), and with a pair of shears cut slits; $\frac{1}{2}$ -inch deep and $\frac{3}{4}$ inch apart, around the open end. With a large nail punch five rows of holes in the side of the can. Bend the slits out at the bottom and tack the can over the holes in the floor. Around, underneath the strips upon which the removable floor rests, tack a narrow strip of asbestos. Over the asbestos tack the large

piece of tin. In the center of the floor, underneath the tin tack a tin bucket-top in which to place the lamp. The tin top will prevent the lamp from being misplaced underneath. With a brace and bit bore three 1-inch holes in the brooder, in places where shown in Fig. 169. Bore the middle row between the piece of tin and the middle floor.

Cut the two openings in the front 5 by 6 inches, and cut one in the partition the same size, over which tack a piece of woolen cloth, in which cut two or three slits. Make an opening in the left end of the brooder 5 by 10 inches, over which tack a piece of wire cloth.

The cost of the material and lamp is about \$3.50.

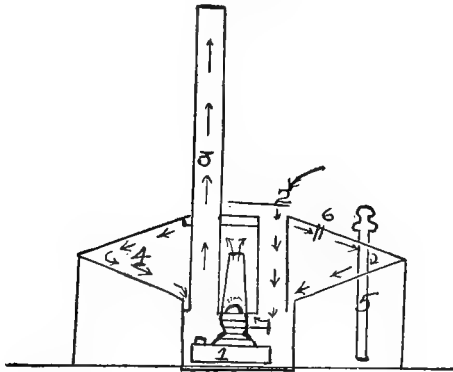

FIG. 170.—A small oil-burning hover sold on the market. 1, The lamp; 2, the intake flue; 3, the draft pipe; 4, the radiating drum; 5, the thermometer; 6, peep hole.

CONSTRUCTION OF THE FIRELESS BROODER

The fireless brooder is a success in the later spring and summer, when the outside temperature is not so cold, or after the chicks have been in a heated brooder for a considerable time and gradually brought down to only their own heat produced by their bodies.

This system requires that several chickens be placed together, as the source of heat is solely from their bodies, and keeping them warm depends upon the conservation of this heat.

Figure 171 illustrates the simple construction of a brooder. The box is made 18 inches square and 8 inches deep. The number and positions of these quilts are regulated according to the weather and the number of chicks in the brooder. In cold weather the quilts should sag so as to rest on the backs of the newly hatched chicks. There should be little or no empty space in the hover. From twenty to forty chicks are usually



FIG. 171.—A cheap but efficient fireless brooder: *a*, Box; *b*, hinged lid showing ventilator openings; *c*, the removable frame, covered with cheese-cloth and on which a sack of feathers or woolen blanket may be placed as an overhead protection. This cheese-cloth is made to sag in the center.

placed in a fireless brooder. Under this method small lots do better than large ones. A small amount of litter is placed in the bottom of the hover and must be changed often. The chicks must be watched closely to see that they are warm enough and yet not too warm. If the fireless brooders are used in connection with heated brooders, keep the baby chicks in the heated brooder for ten days before beginning to cut down

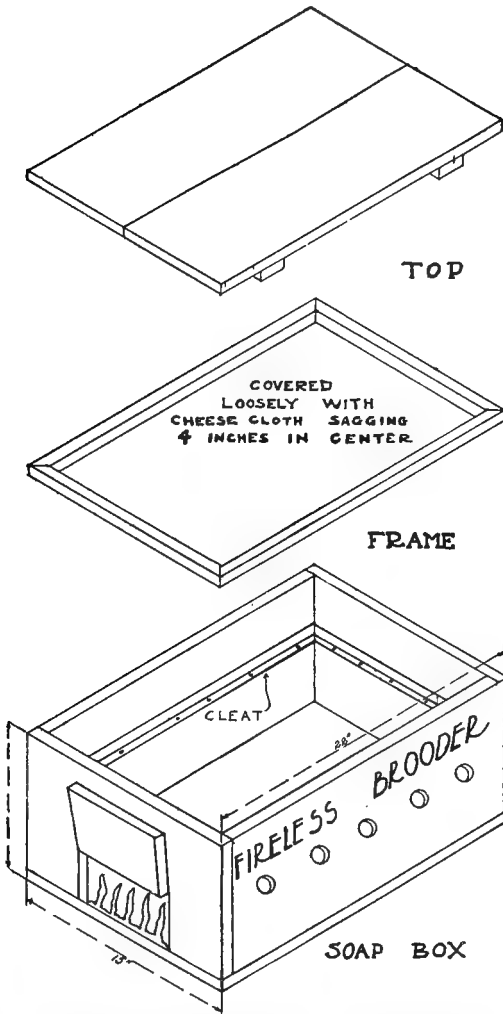

FIG. 172.—A fireless brooder made out of an ordinary soap box. The heat cushion is a bag of chicken feathers or a woolen blanket. Holes in the sides of the box give ventilation. (Pennsylvania Department of Agriculture.)

the heat. Then gradually cut down the heat until there is no heat at all except that generated by the birds. About 2

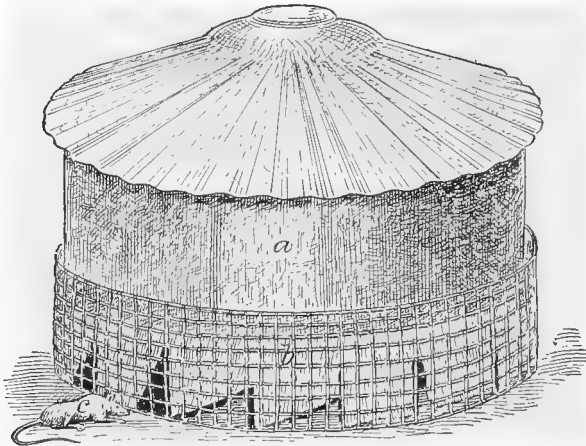

FIG. 173.—A fireless metal brooder sold on the market: *a*, Metal brooder; *b*, a wire netting around the brooder to keep enemies of the chicks out at night; *c*, a rat.

degrees a day is fast enough to cut down the heat. After they are used to no heat except that which they generate they

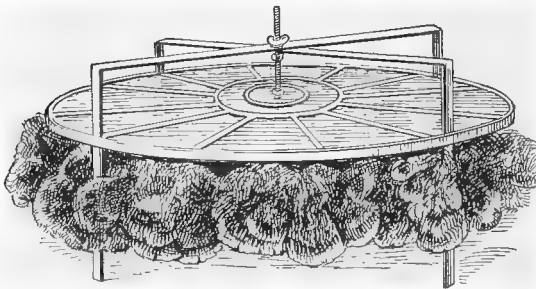

FIG. 174.—The interior part of the metal hover, shown in Fig. 173. These feathers are turkey feathers.

can be transferred to the fireless brooders, and the heated brooders can again be used for the newly hatched chicks.

When the chicks are first placed in the fireless brooder it will be necessary to watch them closely, as it will be found necessary to place them under the hover until they learn to go under it themselves.

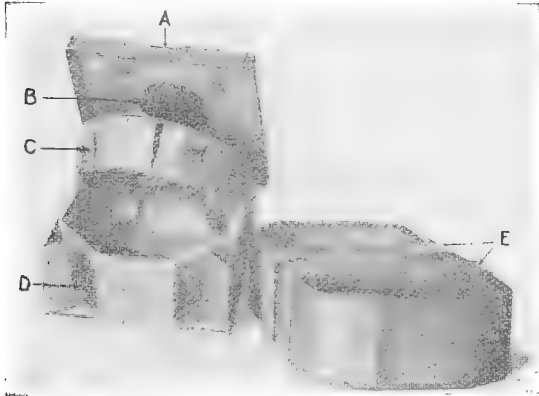

FIG. 175.—The H and D brooder sold on the market: *A*, Celliform construction of ventilation, exit of foul air; *B*, opening through which foul air passes; *C*, hover showing non-ravelling felt; *D*, door from hover chamber to non-crowding yard; *E*, sliding boards to adjust yard.

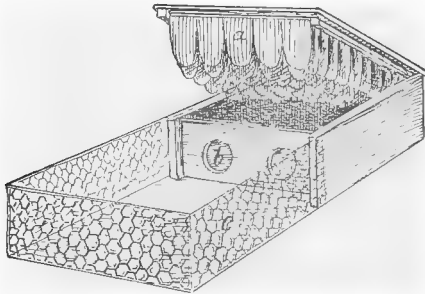

FIG. 176.—A commercial fireless brooder sold on the market: *a*, Strips of felt; *b*, the opening through which the chicks enter to the yard *c*.

When the chickens are first placed in the brooder they should be restricted in their space by placing a board or wire frame around the hover, so that they will not wander away from the hover too far and become chilled before returning to it. The

fence should be gradually moved farther away as the chicks grow older and stronger, and after they have learned to return to the hover for heat. Young chicks should be closely watched to see that they do not huddle together in a corner, and not only get chilled but trample some and smother the weaker under ones. They should be made to return to the hover to get warm when they are cold. Much exposure to cold leads to bowel trouble, weakness, and a heavy death-rate in the flock.

Since weak chickens mean weak constitution, and weak constitution a bird no good, either for fattening or breeding, it is well to immediately kill "those that fall by the wayside."

The *small hover of 50 chick capacity, heated by a kerosene lamp*, is in common use and is very satisfactory. It consists of a metal drum in which is located a kerosene lamp. The lamp receives its air from the room and not from under the hover. The drum becomes heated and the heat is deflected downward, thus simulating a hen in brooding. The hover is round in shape and surrounded with felt reaching within about 1 inch of the floor, and is slitted so the baby chicks may pass in and out with ease (see Fig. 170).

BROODING ON A LARGE SCALE

Hot-water brooding is perhaps the best method in use, for similar reasons as given under the above discussion.

The hot-water methods are used either in connection with hovers or for open pipes and overhead brooding.

As illustrated in Fig. 177, the hot-water system usually has 3-foot square brooders with a 2-foot circular hover. These are arranged in a row, with an alley on one side, or between in those cases where two rows are used. On the opposite, or outside pens and outdoors, runs are provided. These runs outside the building are spaded up and sown in rape or oats, and thus by digging up the ground and admitting sunlight there is allowed the action of the soil's bacteria, which split up the organic matter, polluting the ground, and thus preparing the nitrogen content in a form that can be utilized by the growing plants and purification of the soil results, as well as the effects



FIG. 177.—A view of the heating system of the giant brooder system, showing hot-water pipes, heat drum, and hover.

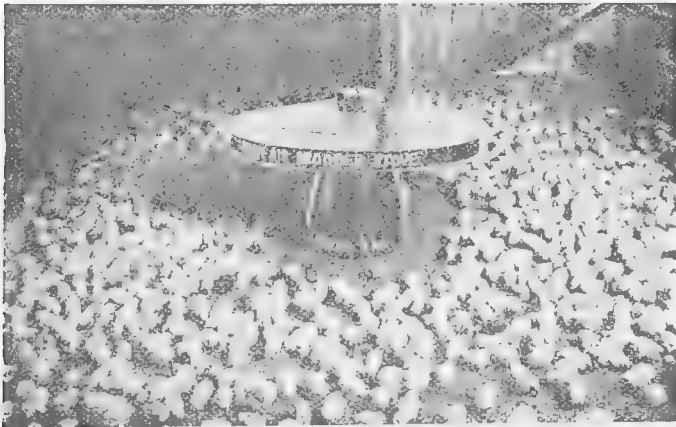
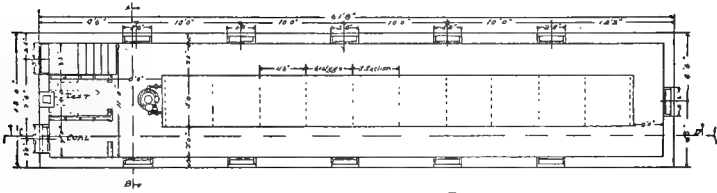
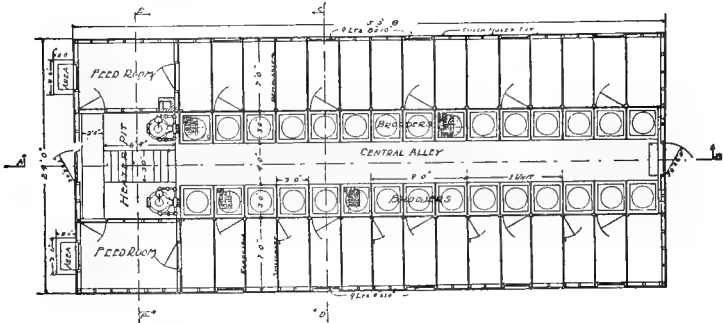

FIG. 178.—A large brooder. The heater is a coal stove regulated with a thermoregulator as other brooders. This metal top becomes hot and the heat is deflected down.



Single Incubator Cellar Plan



Double Brooder House

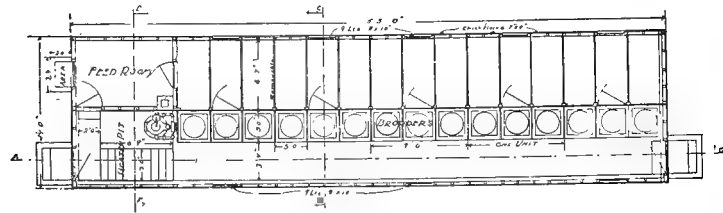

Single Brooder House

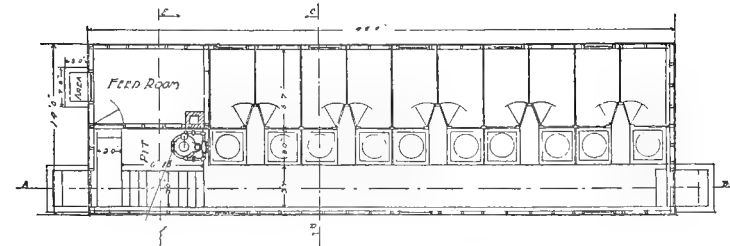

Single House with Alley Between Brooders

FIG. 179.—Floor plan of an incubator cellar and brooder houses. (Candee Incubator Co.)

of the sun's rays in destroying harmful bacteria not of soil's bacteria group.

Each hover usually has a capacity of from fifty to seventy-five chicks.

Hovers are of different types. The two general types are the stationary and adjustable. The heat is conveyed by water in iron pipes in a box close to the floor and the pipes warm the air. Warmed air rises, and the chicks are always assured of a

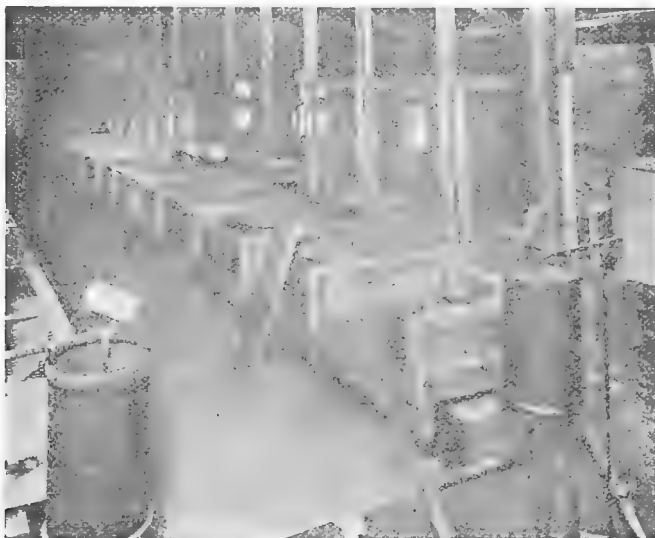

FIG. 180.—The interior of a commercial brooder house, showing compartments and runs.

gentle, ever-changing, pure warm air. Three grades of heat are thus ensured—first, it is warmest under the hover, cooler between the hover and the partition, and cooler in the chick pens. Thus the chick is allowed to get into the temperature best suited to him. The felt on the hover is slitted and the chick can readily go in and out.

Having a small unit hover system chicks of different ages can be raised, as each size chicks must be kept by themselves.

It is estimated that a 20-hover system house will need a floor space of 14 by 66 feet.

Floor plans are given of the double and single brooder houses in Fig. 179. A double brooder house is usually 24 feet wide, with a central alley and a brooder system on each side. A double house is built to run north and south, so that the chicks in one side get the morning sun and on the other side the afternoon sun.

A single brooder house is built east and west, facing the south, with an alley on the north side. The roof is built either on the shed plan or three-quarter span.

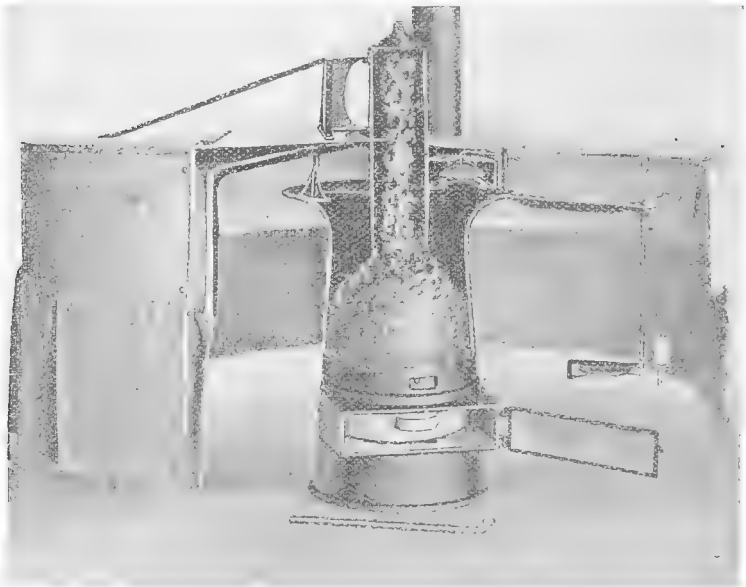

FIG. 181. —A cross-section of an automatically heat-regulated colony brooder.

Another type of large brooder is the colony house brooder. Many take houses 20 by 20 and place in the center a large hover, with a capacity of several hundred chicks. Figure 181 shows one of these hovers. As the chicks become too warm they move away from the stove and project their heads through between the slits in the felt, and finally, if too warm, outside the hover, again returning after becoming cooled off. The

first few days small chicks need to be watched closely, as they may not return when becoming cold, and thus chilled may result in bowel trouble and death of considerable number. These stoves are provided with thermoregulators, as illustrated in Fig. 181.

In duck raising by the large producers pipes are used overhead, as illustrated in Fig. 182. This is the same principle as used in brooding, a thermoregulator being supplied on the stove.



FIG. 182.—A brooder for ducks, showing heater, heat regulator, hot-water pipes, and brooder box.

Phillip has given the monthly hatching expectation in percents as follows:

Month ¹	Per cent., infertile	Per cent., dead germs	Per cent., in shell	Per cent., hatch to eggs set
February.....	20	10	30	40
March.....	10	10	30	50
April.....	8	7	25	60
May.....	8	10	27	55

¹ Term month means time of hatching, eggs being laid three to five weeks previously.

Per cent. chicks that die first three weeks.....	15 per cent.
Per cent. chicks that die after first three weeks.....	10 "
Number eggs set to produce one pullet.....	5 eggs.
Per cent. pullets reared not fit to keep.....	10 per cent.
Per cent. eggs culled from those laid when selecting for hatching.....	5 "
Cost to hatch one egg.....	\$0.013
Average amount of hard coal per day for large brooder stove entire season.....	20 pounds.
Per cent. to the total cost of producing eggs coming from the feed bill.....	50 per cent.

Rearing Commercial Chicks.—In raising birds on a commercial scale it is most economical to brood them with a colony hover which has a capacity of 500 to 1000 chicks (Figs. 178 and 181).

The large deflector hovers may be heated by electricity, coal, gasoline, or kerosene; most usually one of the two latter.

The coal stove burns small nut coal best and may or may not be a self-feeder. The self-feeders are provided with a magazine or central tube which is filled at regular intervals with coal. The small capacity stoves in cold weather may not hold sufficient coal to run them through the night and thus may burn all the coal and the fire disappear before morning. In this case the chicks become chilled, and as a result many are later found sick, becoming puny, and some die. Chilling and similar neglect is one of the chief causes of loss among small birds.

The oil heater has the advantage of the coal burner in that it gives a constant fire. It is necessary to keep the charred material or carbon away from the burner by brushing once a day.

If the chicks become cold they may pile up or crowd in a corner and many of the birds on the under part of the pile become crushed and smothered.

The area about the hover should be kept at a temperature of about 100° F. at all times so the birds do not become cold. They will then adjust themselves to the temperature most adapted to them.

A house 12 feet square is large enough for 500 to 1000 birds. Proper ventilation should be provided with an open front at the floor level and a sliding window so that the netting-

protected front may be kept open in warm weather. In cold weather the window is drawn shut and thus the birds may bask in the sunshine. The wire netting should be of 1-inch mesh.

The Baby Chick Industry.—One of the large branches of the poultry industry to develop during the past few years is the baby chick business. Some commercial hatcheries produce over a million baby chicks. The fact that 47 per cent. of the yolk is inclosed as an abdominal yolk sac for food for the baby chicks for at least seventy-two hours makes shipping of chicks just hatched possible. They have been successfully shipped distances of over 1000 miles.

The following measurements are standard boxes for shipping baby chicks in large consignments:

- 100-chick box—22 in. by 18 in. by $5\frac{1}{2}$ deep—4 compartments.
- 50-chick box—18 in. by 11 in. by $5\frac{1}{2}$ deep—2 compartments.
- 25-chick box—9 in. by 11 in. by $5\frac{1}{2}$ deep—1 compartment.
- 12-chick box—6 in. by 8 in. by 5 in. deep—1 compartment.

Two strips of wood, one-half of an inch square, are tacked on each cover of a shipping box crosswise of the box and two inches from either end. These strips one-half inch longer than the width of the box and are tacked on in such a manner so as to project one-quarter of an inch on either side.

The above procedure prevents the ventilating holes from becoming closed when stacked in transit.

Proper Care of Baby Chicks in Transit.—Numerous claims are paid each year for the loss by death of baby chicks in transit, caused by improper handling or exposure to extreme heat or cold.

On account of the delicate nature of such shipments, it is important that employes handle them with the greatest care, and also expedite the movement as much as possible, always forwarding on first available train and delivering to consignee immediately upon arrival at destination.

In the handling of shipments of baby chicks express or postal employes should be governed by the following rules:

The boxes must be carried on the level; otherwise the chicks will trample or smother those beneath.

Boxes should not be jarred, shaken, or thrown.

The same setting of eggs will not all hatch at the same time. The hatching will extend over a period of from six to thirty-six hours. Breeders take this into consideration when allowing time for shipments to reach destination. If they are delayed enroute beyond the allotted time the oldest chicks are likely to be dead upon arrival at destination, or partly starved and die within a few hours, which makes it necessary that they be given expedited service.

The chicks are generally shipped in double corrugated paste-board boxes properly ventilated for the average temperature according to the season of the year. The chicks' bodies generate enough heat to keep them comfortable in these boxes unless exposed to extremes of heat or cold. Therefore, the boxes should not be placed in the sunshine or set on steam radiator or near a stove.

Shipments of baby chicks must not be closely packed with other freight. While the containers are so built that the air cannot be entirely cut off, the excessive heat and lack of sufficient ventilation will cause the chicks to suffocate.

Shipments must not be allowed to remain out in the open or be hauled about the streets on a cold day without placing a blanket or some similar covering loosely over them. Do not place on floor except in very warm weather.

CHAPTER XXV

MARKETING EGGS

It has been estimated by Lamon and others, after careful investigations, that the loss on the farm due to improper care of the eggs amounts to \$45,000,000 in the United States alone. The greater part of this loss takes place in the hot summertime, when fertile eggs not promptly placed and kept in a cool place soon form embryos and are then unfit for food. It is estimated that about 70 per cent. of the loss has occurred before they arrive in town. This loss has been divided as follows:

Dirties.....	2	per cent.
Breaks.....	2	“
Chick development.....	5	“
Shrunken or held.....	5	“
Rotten.....	2.5	“
Moldy, bad flavor, etc.....	0.5	“
Total.....	17	per cent.

To summarize, deterioration of eggs may be brought about by shrinkage, liquefaction, germination of fertile eggs caused by heat, breakage, dampness, and filthy surroundings favoring bacteria and mold contamination, as well as absorption of odors.

Eggs are a perishable food-product, hence, like meat, are on a retrogressive change as soon as laid until they are consumed. The product on the market is so bad that if it were not a fact that eggs are a staple in the general routine of household economy the consumption of eggs would be greatly curtailed; and, in the face of the fact that eggs are a staple article, it cannot be denied that there is a curtailment of egg consumption at certain seasons of the year.

The greater part of the bad condition of eggs on the market is due to gross neglect, carelessness, and in some few cases to dishonesty and a general lack of appreciation of the perishable

nature of eggs. The eggs from the producer to the consumer take a rather circuitous route. First, the eggs are gathered on the farm, in many cases when convenient, sometimes once a day and sometimes once or twice a week. They are then taken to the house and held until it is convenient to take them to town. Then, just before going to market, perhaps, the children are sent to search for nests, and a few hidden nests' eggs are added to the collection. Many times these eggs are then taken to the store in the country town and traded for merchandise, and then held for a time by the merchant under very unfavorable conditions before being disposed of to the buyer of some packer or wholesale egg house, at which time they are hurried to the city wholesale firms. The common carriers,

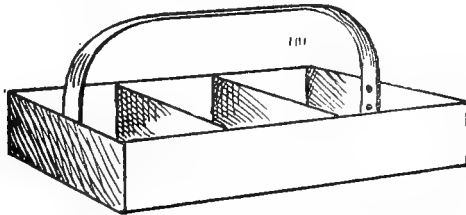

FIG. 183.—A convenient three-compartment egg carrier.

the railroads, and the express companies in particular are unmindful of the fact that the eggs are perishable products much less breakable, and they are thrown in handling by careless employés and allowed to set in the hot summer's sun for hours. When they reach the city they may be placed in cold storage for a while, or they may be placed on the retail market. The deterioration in cold storage is a slow process, and months are required to noticeably affect perfectly fresh eggs. Eggs should be perfectly fresh when placed in cold storage, and should not be placed in storage with fish, kerosene, and other products, as the objectionable odors are absorbed through the pores of the shell into the eggs as milk and butter absorb these objectionable odors. Cold-storage people recognize these facts and provide separate compartments for eggs. The jobber or wholesale merchant candles the eggs and grades them. Thus, in New York City, where there are establishments

candling 10,000 eggs daily, the eggs for sale to retailers are placed on the market in grades as follows: one, two, checks, dirties, and so on.

Dirty Eggs.—The dirty eggs that go to market do not bring as much when sold to the city consumer as they would if they were washed and perfectly clean. As a result of this, the cross-road country merchant makes allowance for all such shortage when he buys the eggs from the farmer. The reform must begin at the farm, and all move together and not market any eggs not first class, as the merchant is afraid of offending the countryman if he tells him he cannot pay so much for the dirty or small eggs, and hence he goes on silently and, unknown to the producer, making his allowances so that he may not



FIG. 184.—A bunch of dirty eggs. Dirty eggs should not be sent to the market.

lose money by his transactions, hence all countrymen selling to the country merchant loses his proportionate amount.

The city grocer, in his eagerness to sell his eggs, frequently places them in a show-window, where in the hot summer time the eggs soon spoil. Under these conditions deterioration goes on by bounds and leaps; he would not think of setting his butter or lard out that way, and if the consumer says anything the grocer blames the producer for selling "rotten" eggs. Neither should the housewife or cook place the eggs she purchases from the store or elsewhere on top of the cupboard or other warm place, where they may undergo considerable change in the course of a week or ten days that may elapse before they are all used. Eggs being a perishable product

eggs. This albuminous material, becoming smeared over the balance of the eggs, furnishes excellent food for bacteria, which may find their way into the pores of the egg so smeared

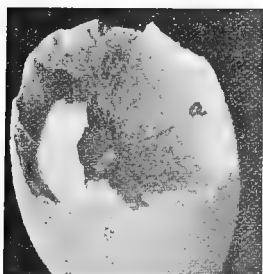

FIG. 189.—A broken egg showing a heavy growth of mold: a, The mold.

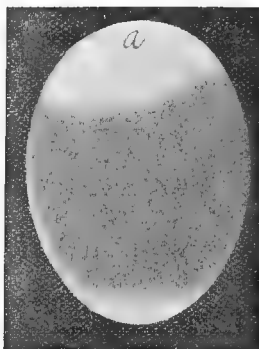

FIG. 190.—An egg the tenth day of incubation: a, The air-cell.

and hasten its spoiling. This is one source of smeared eggs. Care should be used in packing eggs, and smeared eggs should

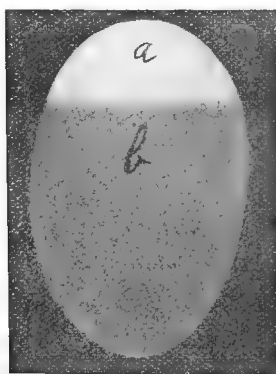

FIG. 191.—An egg the twentieth day of incubation: a, The air-cell; b, the embryo.

be washed or used at home. Wash by dipping them in water, and rub as little as possible, as the rubbing takes off the coating giving the egg the so-called bloom and makes it appear like a

stale egg. Eggs should not be kept long, but in the hot summer time marketed twice a week. In spraying the hen house with either a watery solution of some coal-tar dip, as creolin, or with kerosene, be sure all eggs are out of the nests, as they soon absorb these odors through their pores.

Damp, muddy yards are one source of dirty eggs, and hens should not be allowed outdoors while the yards are muddy. If the house is properly constructed and straw provided, into which the scratch feed is thrown morning and evening, and the mash hopper is located inside the house, as well as the milk and water fountains, the birds are far better off not to be allowed outdoors until the ground is dry.

Droppings allowed to foul the nests can only result in a soiled, stained egg, and such eggs bring less on the markets on account of the soil or stain, even in case they be washed, as a foul egg may always show the stain.

The following rules must be observed to successfully produce and market eggs:

1. Ship only eggs that are produced by healthy fowls kept under proper sanitary conditions and supplied with sound, wholesome feed.

2. If possible, only non-fertile eggs should be produced for market.

3. Fowls must be kept so that eggs will not be soiled in the nests.

4. Eggs should be gathered at least once a day. Twice a day is better, especially in hot weather.

5. Eggs should be stored in a well-ventilated place, which must be kept as cool as possible.

6. It is well to candle all eggs shipped, and any egg that shows any defect should not be marketed.

7. Suitable containers must be used for shipping.

8. Eggs should be sorted of one kind and color.

9. Usually long or thin-shelled eggs should not be marketed.

10. Each egg must be wrapped in some springy material as felt, soft paper or excelsior if shipped by parcel post or express for hatching.

11. Egg parcels should be neat and attractive. The shipper should be supplied with good, tough wrapping paper,

eggs. This albuminous material, becoming smeared over the balance of the eggs, furnishes excellent food for bacteria, which may find their way into the pores of the egg so smeared

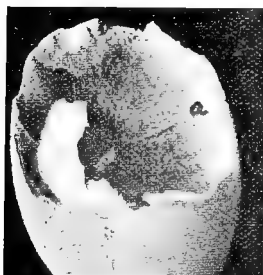

FIG. 189.—A broken egg showing a heavy growth of mold: *a*, The mold.

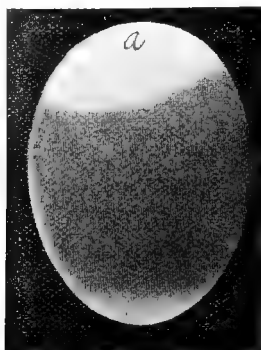

FIG. 190.—An egg the tenth day of incubation: *a*, The air-cell.

and hasten its spoiling. This is one source of smeared eggs.



FIG. 191.—An egg the twentieth day of incubation: *a*, The air-cell; *b*, the embryo.

Eggs should not be kept long, but in the hot summer time marketed twice a week. In spraying the hen house with either a watery solution of some coal-tar dip, as creolin, or with kerosene, be sure all eggs are out of the nests, as they soon absorb these odors through their pores.

Damp, muddy yards are one source of dirty eggs, and hens should not be allowed outdoors while the yards are muddy. If the house is properly constructed and straw provided, into which the scratch feed is thrown morning and evening, and the mash hopper is located inside the house, as well as the milk and water fountains, the birds are far better off not to be allowed outdoors until the ground is dry.

Droppings allowed to foul the nests can only result in a soiled, stained egg, and such eggs bring less on the markets on account of the soil or stain, even in case they be washed, as a foul egg may always show the stain.

The following rules must be observed to successfully produce and market eggs:

1. Ship only eggs that are produced by healthy fowls kept under proper sanitary conditions and supplied with sound, wholesome feed.

2. If possible, only non-fertile eggs should be produced for market.

3. Fowls must be kept so that eggs will not be soiled in the nests.

4. Eggs should be gathered at least once a day. Twice a day is better, especially in hot weather.

5. Eggs should be stored in a well-ventilated place, which must be kept as cool as possible.

6. It is well to candle all eggs shipped, and any egg that shows any defect should not be marketed.

7. Suitable containers must be used for shipping.

8. Eggs should be sorted of one kind and color.

9. Usually long or thin-shelled eggs should not be marketed.

10. Each egg must be wrapped in some springy material as felt, soft paper or excelsior if shipped by parcel post or express for hatching.

and strong twine that stretches very little. Eggs for setting can be more cheaply shipped by parcel post, but market eggs in 30-dozen cases should be shipped by express.

12. Each package must be marked with the name of the sender and also the word EGGS.

13. A purchaser must be found in the city for market eggs. This can be done through personal acquaintance or through advertising, or one may sell through the commission men.

14. If selling to private parties the price, based on market quotation, must be determined, and an agreement entered into.

15. A method of remittance for shipments must be established.

16. Weights of packages must be ascertained and the postage determined.

17. The producer in making an agreement with a customer should undertake to stand good for eggs lost by breakage in shipping.

Certain feeds affect the color of the yolk. Insufficient supply of green feed is likely to result in the formation of very pale yolks. Cottonseed meal causes the yolks to be very dark, in fact yellowish brown due to two pigments found in the meal—a yellow crystalline substance and a brown resinous material. Some hens store up in the yolks more of these pigments than others. Alfalfa causes a rich yellow-colored yolk, sugar beets a very pale, and corn and kale a rich yellow color.

Some markets prefer white eggs to brown eggs. For instance, the first week in November, 1914, the writer saw good, even-sized, white fresh-laid eggs, weight at least 2 ounces to the egg, sell at sixty cents a dozen on the New York City market, while the same grade, except brown instead of white, brought four cents a dozen less.

Some time was spent in a candling room, where storage eggs are candled. In this establishment six commercial candlers handle 10,000 eggs a day. The cold-storage eggs are divided into four classes, as follows: number one, cold storage; number two, cold storage and checks or dents, and the fourth class are those that are spoiled and are thrown into a garbage can. At this time number one cold-storage eggs were selling

for thirty-three cents a dozen on the retail market and number two for twenty-eight cents, while checks, or those found broken but not leaking, and yet in candling showed the contents to be fit for food, sold for twenty-three cents. Why different grades? It must be because of improper handling before being placed in cold storage else they would have all been of one grade.

If the following rules were carried out by the different parties handling the eggs from the hen to the consumer, there would be a greater part of the 17 per cent. loss saved, which percentage runs into an economic saving of millions of dollars a year in the United States alone.

The farmer should keep only pure-bred stock of the general purpose breeds, as the Rocks, Wyandottes, Reds or Orpingtons, unless he intends to enter the commercial egg-production

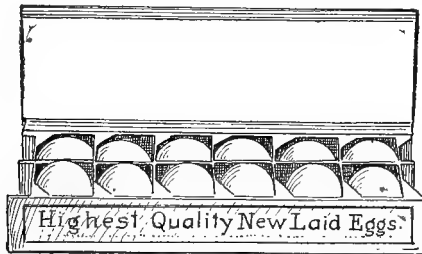

FIG. 192.—The proper way to pack and deliver eggs. These cartons can be bought on the market very cheaply, about one-half of a cent a piece.

field, in which case the Mediterraneans, as White Leghorn or Minorca, may give better results. He should not keep stunted birds in his flock, or breed from birds that have gone through serious illness. Strength and vigor in the birds must be kept in mind in making selections in egg as well as for other production.

The house must be kept clean, the birds free from vermin, and only good clean food given.

Pullets for early laying should be hatched early. For the heavy breeds February and March, and for the smaller breeds the last week in March or first week in April. Poultry on the farm must be given the care and attention it deserves, not los-

ing sight of the fact that the hen aids the cow in keeping the table supplied.

All male birds should be removed from the flock as soon as the breeding season is over, then the eggs produced being infertile cannot spoil from chick development. The formation of the egg is in no way influenced by the male, the egg being formed regular as the ovum in higher animal life. Infertile eggs will be produced just as often as if there was a chance to fertilize every one laid. The nests must be clean, dry, and sanitary at all times. The eggs must be collected at noon and in the evening, and kept in a cool place and marketed twice a week. Cover eggs in storage so the dust cannot accumulate on them, using preferably a clean, fresh laundered cloth. Pack securely in a box, using cotton-seed hulls, bran, or saw-dust when taken to market to avoid breakage.

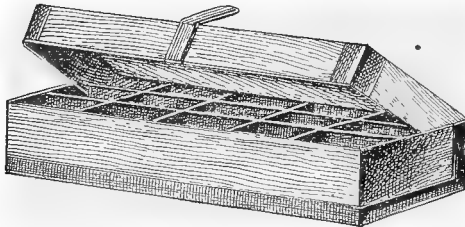

FIG. 193.—The parcel-post egg-shipping box. Eggs for sitting are shipped safely by parcel post.

If the merchant would observe the following rules there would be prevented a loss from his careless handling: Buy on a loss-off basis and encourage other merchants to do the same. Candle all eggs he buys. Keep in mind that eggs are a perishable product and properly store them. Keep in mind that fresh eggs at any season of the year are more valuable than stale eggs, and that a satisfied customer is worth a dozen unsatisfied. When shipping, pack in strong, clean cases and fillers.

If the buyer would buy direct from the farmer and make frequent and regular collections and pay a premium for quality, and not hesitate to condemn dirty, bad, small, and broken eggs, and encourage the farmer to keep more poultry and better poultry, and when buying from the country merchant to make

frequent shipments and to buy on a quality basis, the egg consumers would be better satisfied, as the product would rapidly improve.

If the railway and express companies would observe some of the following suggestions there would be less loss from their careless and unmindful handling.

Handle the egg cases with care, provide suitable accommodations, guard against exposure to cold and heat, and deliver promptly to the consignee.

If the dealers and packers would observe these suggestions there would be a saving at their end of the line.



FIG. 194.—A cheap but efficient way to ship baby chicks.

To make it clear to the producer that quality counts more than quantity, and that he is paid for his product on a quality basis and quality alone.

If the retailer was to buy his eggs guaranteed quality and always sell his eggs for what they are represented, and come back on the wholesaler for any shortage along this line, there would be better satisfied customers. If brands of eggs could be established that would be guarantee in themselves to the consumer of good quality, at least part of the problem would be solved. In fact, commercial plants have already taken up this phase, stamping their name and date on the egg the day it was laid. The city retailer, as well as the wholesaler and the producer, should realize that an increased quality means an increased consumption of that product.

The consumer should demand:

New-laid eggs of good size and color, and insist that they be clean. They should learn to distinguish a new-laid egg from a stale egg, and a fresh egg from a storage egg. Demand compensation for the bad eggs supplied by the seller. One should be willing to pay a small premium for a strictly first-class product, and in the cities they do. When eggs are purchased not to overlook the fact that they are perishable, and that they, like milk and butter, absorb odors, and keep them in proper refrigeration as pointed out before.

Car Lot Shipment.—Eggs may be shipped in car-load lots. Thirty dozen cases are used. The cases are so packed in the car as to allow a free passage of air around the boxes. A scantling holds the cases off the floor and allows a free circulation of air under the cases. The average size car will hold about 400 cases. The bunkers are filled with ice but no salt is used. The temperature must be about 33° F. to obtain the best results. Salt in the ice will cause the temperature to fall too low, which if it reached a point below 30° would be injurious to the best quality of the egg since the egg freezes at about 28° F.

Dressed poultry may be shipped in car lots. The boxes are so placed that there is a free circulation of air around the boxes. In dressed poultry the ice is often salted. The addition of 10 to 15 per cent. salt will cause a very low temperature often as low as 7° above zero at the lower border of the bunker. A new scheme in bunker construction has resulted in better results in shipping dressed poultry. There is in this new method, a metal net which receives the ice so that there is a free circulation of air around the ice, and as a result the temperature can be kept below 33° in the warmest part of the car.

The bunker is the compartment for ice at the end of the car, the top opening is the hatchway, the side or wall of the bunker next to the inside of the car is the bulkhead. The water is drained from the car by a trap which prevents hot air from rushing into the car. The car is insulated.

How to Load Cars of Eggs.—Much of the heavy loss in shipping carloads of eggs is caused by the cases being im-

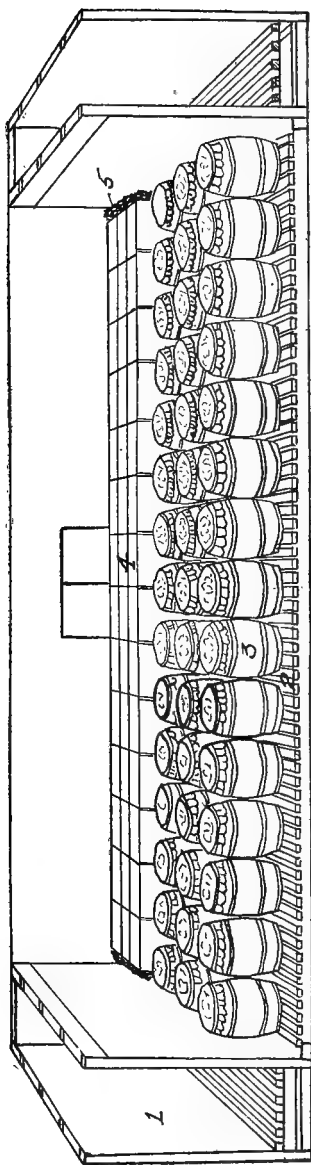

FIG. 195.—A mixed car of eggs and dressed poultry. 1, The bunker; 2, the slatted floor to ensure free circulation of air under cases; 3, barrels of dressed poultry; 4, cases of eggs; 5, straw as buffer material.

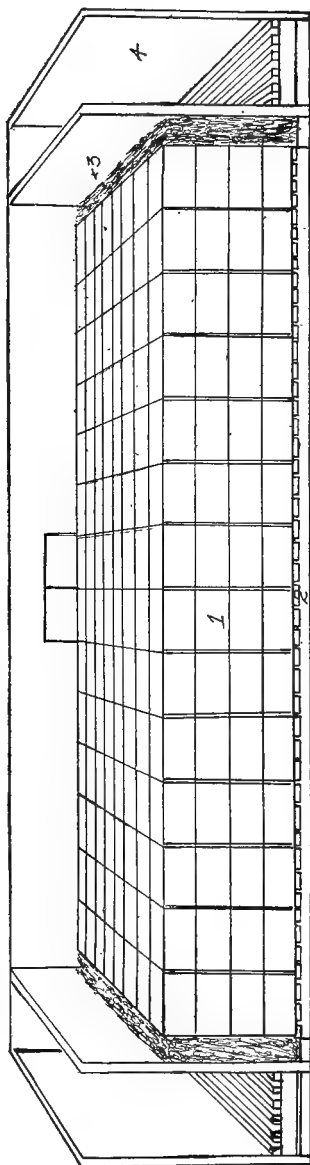

FIG. 196.—A car of eggs. 1, Cases of eggs tightly packed; 2, the slatted frame to allow of free circulation of air; 3, straw as buffer material; 4, the ice bunker.

properly packed in the load. To prevent damage to eggs in transit the cases must be properly stowed, braced, and buffed. Cases must be standard and new, with at least five cement-coated three-penny nails at each corner of sides, bottom, and at center partition. Use medium or heavy new flats and fillers. Spread top and bottom cushions and make them fit. Make the load fit the car exactly. There should not be an inch of play lengthwise of the car when it arrives at destination. Load from the side, make the load solid, put braces under the cases, make the buffing fit the space tightly, and have



FIG. 197.—Shipping day-old baby chicks.

load even at the doorway. Don't nail braces to sides of car against incomplete top layer; they seldom hold in place and often are the cause of damage. They injure the efficiency of the car insulation. The use of small under-case braces will prevent all of this.

Preserving.—At times eggs are preserved at home and are placed in a solution of water-glass, which is made as follows: add 1 part of water-glass to 9 parts water, and place the eggs in a glazed earthen jar with small ends down, covering the upper surface 2 inches deep. Cover jar with tight-fitting lid or paper to prevent evaporation of the water.

A 1-gallon jar will hold 40 eggs; 2-gallon jar, 80 eggs; 3-gallon jar, 120 eggs; 4-gallon jar 160 eggs; 5-gallon jar 200 eggs and a 10-gallon jar 400 eggs. The jar should be scalded and the water boiled. Set the jar containing the eggs in a cool place. Select only well-formed eggs possessing thick shells, so the weight on the lower layers do not break some of them. When taking the eggs out wash them with water, rubbing as little as possible. Water-glass preserved eggs do not bring as much as fresh eggs on the markets where eggs are sold according to market grades.

Eggs may be preserved by freezing or by drying.

The Freezing Method.—The eggs are broken out of the shell in such a way that the contents do not come in contact with the shell. In some cases the yolks and albumen are separated and each placed in a separate can and sold as frozen yolks or frozen albumen. In other cases both yolk and albumen are placed in the same can. The size can differs with the different plants; usually either 30-pound or 50-pound cans are used. The eggs thus prepared are kept at a temperature near zero till they are to be marketed. Usually small, ill-shaped, dirty, or checks are thus disposed of by the larger storage firms doing a large egg storage business.

The Drying Method.—In the drying method the eggs are carried in pipes to the dryer in which the egg material is spread out in a very thin layer over a drum. This drum is heated by dry hot air. The egg material dries by the time the drum has revolved around and the dry egg is then scraped off and carried away from the drum and put up in packages and sold as dried or powdered egg. One pound of dried egg represents 30 eggs or $3\frac{1}{2}$ pounds.

Boiling Oil Preservation.—Recently a firm has developed a method of sterilization of the surface and sealing the egg pores by passing the eggs through boiling oil. This kills all germs it comes in contact with and sears the inner membrane, but is said not to alter the value of the egg content. It thus prevents further contamination and prevents further evaporation through the pores of the shell.

There are three channels through which eggs may be marketed, namely: (1) The large cities, through the commis-

sion merchants; (2) the nearby towns, to merchants, hotels, restaurants, or summer resorts; (3) the family trade of nearby towns.

Route of the Egg from the Producer to the Consumer.—The route the egg takes from the hen to the table may vary. In the graphic illustration given in cut No. 198 we see that the egg may take a start in one of five directions, and that the city consumer may receive his eggs in one of three directions. The producer may sell to the consumer, as is the case where the

THE EGG ROUTE

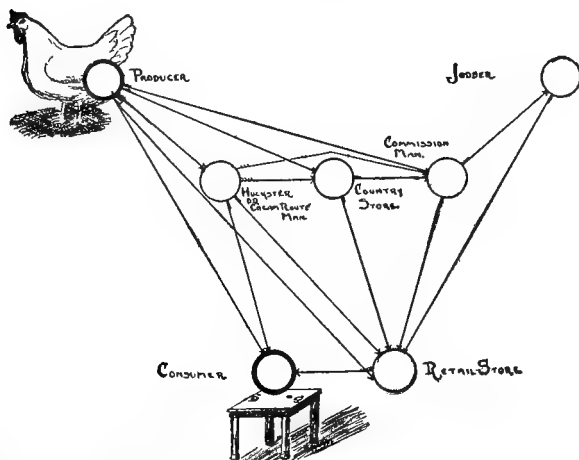

FIG. 198.—The route of the egg from the producer to the consumer.

producer lives in close proximity to towns or cities, where there are families, hotels, and restaurants that do not produce but purchase their egg supply. This we may term family and nearby restaurant trade. This is one of the most remunerative trades to the producer. Some producers deliver their eggs "same day laid" or "next day laid" in which case they are collected at noon or middle of the afternoon and hurried off on the delivery wagon. Usually these eggs bring five to ten cents above the market price.

In many instances the producer sells his eggs to the retail stores of the larger towns, and these retail stores in turn sell to the consumer.

The third route the egg may travel is by way of huckster or by the cream route. The huckster traveling through the country collects the eggs and then disposes of his holdings in one of three ways. There are some who go to the larger

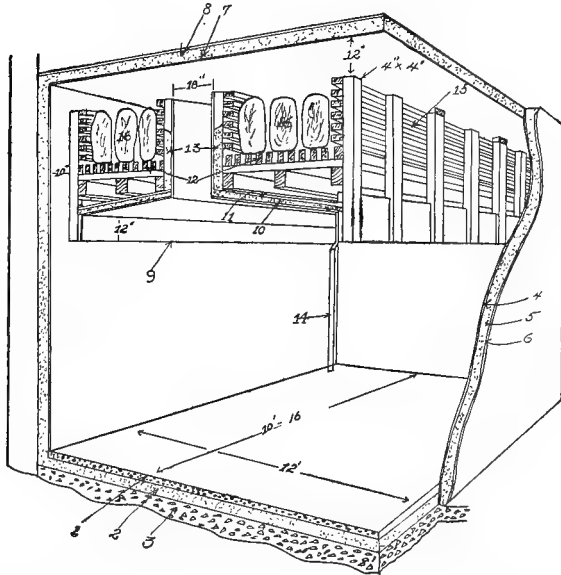

FIG. 199.—A typical ice chilled room—with overhead bunker. 1, Concrete; 2, cork; 3, concrete base; 4, $\frac{1}{4}$ -inch rough and $\frac{1}{4}$ -inch finish coat; 5, 4-inch cork; 6, $\frac{1}{4}$ -inch rough $\frac{1}{4}$ -inch finish; 7, $\frac{1}{2}$ -inch plaster; 8, 5-inch cork; 9, 2-inch cork; 10, 2-inch cork; 11, drip pan; 12, removable racks; 13, 2-inch cork; 14, drain pipe; 15, ice rack; 16, ice.

towns, or even the city where they are close to the same, and sell direct to the families; or they may sell to the retail stores and hotels, or may ship direct to the commission man in the city. The cream route comes in the huckster class; that is, the creameries after collecting the eggs may and do sell to families, clubs, hotels, and restaurants, to the better class

retail grocery stores, and the surplus is sent to the commission man of the large cities.

The fourth route the country eggs may take is to the country store, where they are traded for merchandise. The country store in turn disposes of its collection to the hotels and restaurants of larger cities or sends them to the commission man in the large cities.

Fifth, the producer may ship direct to the commission man of the cities, who in turn may sell either to retail stores, restaurants, hotels. Or in case the market becomes "loaded up" he may sell to the jobber.

Refrigeration.—Refrigeration is to the nation what the house refrigerator is to the home. It is a means of preserving food from the time of heavy production till the time of scarcity. Refrigeration of dressed poultry and of eggs is used in two ways: First, to prevent deterioration in the ordinary passage of goods from the producer to the consumer, and second, to hold goods from season of surplus production until season of scant production.

There are specialized rooms for the storage of eggs and others for dressed poultry. These storage warehouses are found in the large cities and are of two kinds, public and private. The private houses are those used by the owners for the storage of their own products. The public houses are those doing a warehouse business, that is, in which an outsider may store their products on payment of a storage fee.

It is estimated that 15 per cent. of the eggs produced in the United States are placed in cold storage for a time. About 80 per cent. of these are placed in storage during the months of April, May, and June. They are stored in 30-dozen cases.

In dressed fowls roasters go into storage in November and December, fowls in December and January, broilers in July and August, and turkeys mainly in December and January.

The average number of months these products stay in storage has been given as follows: poultry 2.42 and eggs 5.91.

The eggs placed in storage in April are likely to be held as much as seven months, those in May six months, June five months, July four months, and August three months.

The percentage of dressed poultry delivered from the storage

warehouse at the end of four months was 85 per cent., seven months 96 per cent., and ten months 99.9 per cent. Of eggs by the end of four months 22 per cent., seven months 75 per cent., and ten months 99.9 per cent.

Factors Affecting the Cost of Marketing.—Eggs may be broken and also shrink during the process of marketing. Live and dressed fowls shrink in transit. Milk fed live poultry shipped a distance of 500 miles may shrink 10 to 16 per cent.



FIG. 200.—Egg storage room. Note the cases are held apart by cleats to allow of free circulation of air.

if not fed before being cooped. If fed whole corn at time of cooping and rushed this shrinkage may be reduced to 4 or 5 per cent. Occasionally heavy shrinkages which cannot be accounted for occur. Corn-fed poultry do not make such heavy shrinkage. Dressed fowls make shrinkage, and if not properly cooled and packed as well as refrigerated may spoil.

Eggs may be purchased by the retailer from the commissionman and paid for by the "case count;" that is, for all

the eggs regardless of whether they are all marketable. He may pay for them "loss off," or have them candled and pay for only the good eggs.

The New York State Food Commission gives the following analysis of costs of marketing a dozen eggs based on a price of twenty cents paid to the farmer, and assuming that they are held in storage.

Producer's price.	\$0.20	\$0.20
Shipper's charges:		
(a) Labor in collecting and packing	0.005	
(b) Cases, fillers, and packing.	0.0073	
(c) Transportation charges to city.	0.0106	0.023
Commission for handling.	0.0100	0.01
Jobber's charges:		
(a) Cartage from dock to store.	0.00133	
(b) Candling and grading.	0.00666	
(c) Storage and insurance.	0.016	
(d) Jobber's profit and charges.	0.01	
(e) Delivery to the retailer.	0.004	0.038
Retailer's charges:		
(a) Operating expenses 10 per cent.	0.0271	
(b) Retailers profit 5 per cent.	0.01497	0.042
Price paid by consumer		\$0.313

In the above estimates the total spread including storage was 11.3 cents per dozen eggs. The producer in this case received 63.9 per cent. of the final price.

Express or freight charges as an element of marketing cost depends on four things: (1) Distance over which goods are shipped. (2) Relation between bulk of a commodity and its intrinsic value. (3) The weight of the package in which goods are carried. (4) The amount and special care required during transit.

Poultry and eggs may be carried by trolley; freight; ocean freight, as between countries; or coastwise; inland waterway, as the rivers and great lakes.

Cost of Storage.—An analysis of storage charges on poultry and eggs at hypothetical cost prices in New York City as follows:

Commodity	Hypo- thetical cost	Storage charge, 6 months	Insurance at 0.416, 6 months	Interest 6 months at 6 per cent.	Total storage expense	Increase in cost due to storage
Poultry.....	\$0.18	\$0.0100	\$0.000522	\$0.0054	\$0.195922	\$0.016
Eggs.....	0.20	0.0089	0.000590	0.0060	0.215490	0.016

The laws require that all products placed in storage be stamped giving the name of the product and date of entry and date of withdrawal.

Marketing.—Ordinary marketing processes may be divided roughly into four successive steps as follows: (1) Producer. (2) Country shipper. (3) Transportation company. (4) Wholesale dealer. (5) Retail stores. (6) If the market is glutted the wholesaler may sell to the jobber and the product be placed in a storage warehouse. (7) A drayman may be introduced between any of these dealers as an additional transportation factor in the chain. All of these add to the cost of marketing.

Ways in which Poultrymen may Sell Their Products.—The poultryman may sell his product in any one of five ways as follows: (a) Direct to the consumer by 1, going direct to the residence; 2, through municipal markets; 3, by parcel post or express companies to clubs in the cities who distribute the eggs or poultry among themselves, or to a single individual. (b) By selling to local stores. (c) By shipping direct to dealers in large cities. (d) By selling to a local buyer who does a jobbing business. (e) By shipping through a coöperative association.

Construction of Storage Houses.—The outside wall of the storage houses are made of brick or reinforced concrete. The inner wall is given a coat of cement, next a 4-inch layer of insulating material as cork, and on the inner side a layer of cement. Some walls are provided with two layers each of cork and cement. The inside walls are of frame construction as follows: studding, sheathing paper, asphalt, cork, asphalt, cork, and a surface cover of cement. The ceiling is covered with 2 inches of cork, a layer of asphalt, another layer of cork, and a surface cover of cement. The floors are made as

follows from bottom up: boards, paper, asphalt, cork, asphalt, concrete, cement finish coat (see Fig. 199).

THE EGG CASES AND FILLERS

The standard egg case commonly used by 75 per cent. of the trade is a $\frac{3}{16}$ -inch veneer cottonwood case. Some buyers use a trifle heavier case, that is, one 7.32-inch veneer. Some shippers use a $\frac{3}{16}$ -inch tupelo case, which differs only in the wood out of which it is made. Others use a $\frac{3}{16}$ -inch gum case. Some use a drop cleat end, that is, having six cleats to the case, two of which are attached to the top and lap down over the ends, resting on a cleat that is recessed from the top of the end. Others use a flush cleat case, which has four cleats to the case, and the top is nailed directly to the case and no cleat is attached to it.

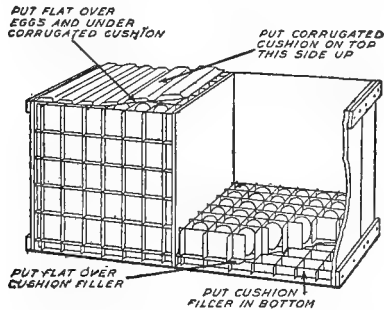

FIG. 201.—How to pack a case of eggs.

There are in use four different weights of fillers: No. 1, 31b, medium, and No. 2. The medium filler is used by 75 per cent. of the trade. The No. 2 is "outlawed" by the Railroad Company, but is still used in some localities, but very seldom for shipping purposes. The No. 1 and 31b fillers are used by certain packers, also by those who are shipping eggs in what is known as pick-up cars, that work on local freight, stopping at each station, where other eggs are added to the car. Some use a white filler for packing export eggs on account of its color and a trifle less odor. Nearly all the trade use a straw-

board filler. Some use corrugated cushions on the tops, cushion fillers on the bottoms. Others use excelsior pads, while still others use loose excelsior on both tops and bottoms. A few use corrugated cushions on the ends and centers to protect the eggs from jarring.

It is proportionately cheaper per dozen eggs to ship them in 30-dozen cases rather than in 15-dozen or smaller lots.

The U. S. Department of Agriculture states that cottonwood possesses certain advantages over other woods as material for egg cases. It does not warp or crack as easily as other woods; it is lighter, softer, more easily handled, and is odorless.

It is found that fillers which are old or have been wet stand less pressure than new uninjured fillers. The new fillers are the most satisfactory.

The tips of the fillers should be strong and prevent the eggs from coming in contact with the wood of the box. Cement covered nails have a great advantage in holding power over those not cemented. This coating usually consists of resin mixed with wax. The heat developed in driving the nail fuses the coating and causes it to adhere to the wood.

In shipping eggs in carload lots it is found that if the boxes are not packed tightly the entire mass of cases shift from end to end as the train starts and stops or in switching operations. If this occurs there will be considerable breakage in the cases at the ends of the car.

Eggs are sometimes broken by the handlers stepping on the tops of the cases. The case should not have so much excelsior or other material in it that the top bulges slightly upward, or in settling, as a result of other packages being placed upon it, there will be breakage of some of the eggs. The car can be packed with straw in between the cases and car ends. While this acts as a buffer, preventing to a certain degree breakage, yet it prevents a free passage of cold air from the ice bunkers.

Many eggs become broken by not using cushions or the excelsior not evenly distributed.

THE COLLECTING OF EGGS ON CREAM ROUTES

The question of markets is one that is of vital interest to all producers.

A cream and egg route is simply an organization of farmers for the purpose of providing an economic means of marketing their cream and eggs. There are three ways in which these routes can be organized. Where a number of farmers live together in a comparatively small community it is usually found most economic for each farmer to take his turn collecting the cream for his neighbors and carrying it to the creamery or shipping station. For instance, if six farmers were living somewhat near together and cream were collected three times a week, each farmer would collect the cream and eggs every two weeks. If there were only three in a community, each farmer would collect the cream once each week.

When farmers do not live in thickly settled communities, but are scattered out along the road, it is best to hire the farmer on the end of the route furthest away from the creamery or shipping point to collect the cream and eggs. At the end of the month each farmer along the route would pay his share of the cost of collection, according to the amount of butterfat and eggs shipped.

Where farmers are so situated that a "belt line" route can be organized, it is economy to have the cream gatherer located at the creamery or the shipping station. He would then leave his home in the morning, collecting the cream on one road going out and collecting on some other road on his return. Since it is necessary to collect cream and milk and eggs three times a week, the route man collects Mondays, Wednesdays, Fridays in one direction, and Tuesdays, Thursdays and Saturdays in some other direction. In this way he would be busy each day in the week and would be collecting cream and eggs on both outgoing and returning trips. With a horse and buggy and fair roads he could make a circuit of twenty-five to thirty miles a day.

COÖPERATIVE MARKETING

The Egg Circle

By uniting several egg producers in an association more can be accomplished in these essentials. One very successful egg company has a large incubator house with 12,000 eggs capacity, where early chicks are produced for the members at a low cost.

This is done in order to obtain early maturing pullets, thus securing eggs during the fall, when eggs are usually scarce. The company also has a receiving room for eggs where they are candled, sorted to weight (about 24 ounces to the dozen), packed in cartons, and shipped on contract orders. Their eggs are all guaranteed to be according to grade; they advertise the fancy grades on their cartons and cases, and market prices are paid to the members. Twice a year dividends are paid each member in proportion to the amount of eggs marketed through the company and the time of year eggs were brought in, a larger dividend being paid per dozen for eggs brought in during the fall and winter than for those brought in during the spring and summer, estimated by months. A regular trade is established with discriminating consumers with city clubs, with the best class of hotels and restaurants, and with fancy grocers for a supply each day or week.

The reputation thus established enables this association to fix its price at several cents per dozen above the regular market quotations, as fancy trade is willing to pay a premium for a guaranteed article. Most egg circles cooperate in buying their chicken feed and other poultry supplies.

Attractive Package.—All food products should be delivered in a clean, attractive package. Some of the most successful egg shippers have discarded the dirty wooden case and are using a heavy fiber-board gift case, which will hold from 15 to 30 pasteboard cartons. Each carton has compartments for 12 eggs. Upon both the cartons and the case can be printed such advertising as may be wished. This style of package is especially desirable for the fancy retail grocer who can have his firm name included in the advertising. The fiber-board case is not expensive, forms a good protection to the eggs in shipping, and is worthy of trial.

ORGANIZING AN EGG CIRCLE

(Suggestions of the U. S. Department of Agriculture)

The following forms are offered as aids in organizing, managing, and auditing a community cooperative eggs circle or asso-

ciation. They are subject to such changes as will make them best adapted to the local conditions.

While at first the number of eggs to be marketed may not warrant a central station, with a manager to inspect, grade, and market the whole product, the aim should be to develop to that state. It is the only way to secure a uniform grade which will attract the highest class of trade.

PRELIMINARY AGREEMENT

We, the undersigned, citizens of County, State of, do hereby agree to form ourselves into an association, to be known as the Egg Circle, and agree to abide by the rules for the conduct of the business which may be adopted by a majority of the members in regular session.

Name	Address	Number of hens kept

CONSTITUTION

ARTICLE 1.—*Name*

The name of this association shall be the Egg Circle and its place of business shall be at

ARTICLE 2.—*Objects*

The objects shall be to secure and improve better strains of poultry; to produce more eggs of good color and size; to handle eggs more carefully in order to avoid waste; to pack a uniform grade of clean, fresh eggs, in order to be able to guarantee them and thus create a reputation; to market same more directly to the consumers; to purchase supplies in a coöperative way, and to do such other things as may prove of benefit to the members and the community.

ARTICLE 3.—*Officers*

The officers of the circle shall be a president, vice-president, secretary-treasurer, and two trustees, the five to constitute a board of managers.

They shall be elected at the regular annual meeting, to be held on the second Monday in January of each year and they shall serve one year or until their successors are elected.

ARTICLE 4.—*Duties of Officers*

The officers shall perform the usual duties connected with their several offices. Unless the board of managers elects a manager, the secretary-treasurer shall act as manager, and, in addition to keeping all records, shall have charge of the buying of all supplies; the collecting, inspecting, grading, and packing of the eggs; the securing of orders from the most profitable class of customers (such as first-class hotels, restaurants, and private trade); the making of all shipments and collecting of accounts, settling with all members on the same basis for the same class of eggs.

The manager shall give a bond in twice the sum that he is liable to handle at any one time, the cost of said bond to be paid for by the circle. He shall keep a careful account and record of all money transactions, which account shall be inspected and audited not less than once in each three months by two component persons, with a yearly audit just before the annual meeting, the report of such audit to be made in writing to said annual meeting.

ARTICLE 5.—*Membership*

Any person may become a member of this circle by paying the annual fee of \$1 and agreeing to live up to the rules of the circle.

ARTICLE 6.—*Voting*

Any member in good standing shall be entitled to cast one vote at any meeting of the circle, but no proxies shall be allowed.

ARTICLE 7.—*Amendments*

This constitution may be amended at any annual meeting or at any special meeting called for that purpose, provided that two-thirds of all members present vote for such change; and provided further that at least 10 days' notice of such proposed amendments shall have been given members.

BY-LAWS

1. Members must deliver to the circle all eggs produced by their hens, except those for home use, and those from stolen nests of unknown age.

2. Eggs must be gathered daily (twice daily in hot or muggy weather) and kept in a cold place. No eggs older than seven days shall be delivered to the collector. Artificial eggs only may be used as nest eggs,

and the nests must be kept clean. Broody hens must be confined away from nesting hens.

3. Members may deliver eggs to the circle only from their own hens.

4. The manager shall have power to pay a higher price for white or brown shelled eggs, according to the demands of the market.¹ Eggs that do not average 24 ounces to the dozen shall be paid for by weight on the above basis.

5. With the exception of during the mating season, all male birds must be kept apart from the flock of hens. The manager shall have power to pay a small premium for these infertile eggs, if the market warrants.

6. The manager may refuse to accept "dirties." If accepted, they shall be taken at a discount.

(If each member is permitted to pack the eggs, the following by-law applies:)

7. Each member shall receive a rubber stamp, giving the brand of the circle and the recorded number of the member. Each egg must be stamped plainly and neatly on the big end. Only fresh, clean eggs of standard weight, and uniform color may be packed in the cartons, holding a dozen each, the cartons being furnished by the circle, and the member's stamp also being placed on the face of the carton. In case any complaint is received in regard to any eggs, the member whose stamp is on the eggs shall be charged with any expense of settlement made necessary by his carelessness.

(If the eggs are brought to a central house for packing, the following by-law applies:)

8. All eggs shall be collected and delivered to the circle packing house by such means as the annual meeting may determine. Each member shall be given a receipt for the number of eggs he delivers. These eggs shall be candled, graded, and packed by the manager or his assistants and each member be given credit for the number of each grade. All eggs of the same grade shall then be pooled, and when sold payment shall be made on the basis of the price received for each grade, less all necessary expenses.

9. The manager shall be paid a commission of . . . per cent. on the net sales of the business, not to exceed a total amount of \$ per year.

10. Any member failing to live up to these by-laws may be expelled from membership or sufficient sum withheld from his sales to reimburse the circle for any loss occasioned by his failure. In all such cases the member shall first have the right to be heard before the board of managers.

¹ New York and Chicago markets will often pay several cents a dozen more for white-shelled eggs, while Boston prefers the brown-shelled eggs. It is a case of market preference.

11. Members may voluntarily withdraw from the circle, to take effect only at the end of the business year, by giving thirty days' notice to the manager.

COMMUNITY EGG CIRCLE RECEIPT FORMS

INSTRUCTIONS FOR PRINTING AND BINDING

Forms A, B, and C should be numbered in triplicate. Form A (original) should be printed on white paper, Form B (duplicate) and Form C (triplicate) on paper of different tints, preferably light bond, and bound in books of 25 numbers to the book. Forms B and C should be perforated.

INSTRUCTIONS FOR USE

The collector enters the total number of eggs received from a member in the spaces provided on Form A, using carbon sheets so that the date, member's name, circle number, and number of dozen eggs collected are given on all three forms. The collector, at the time of collection, delivers Form C to the member, which is a receipt for the number of eggs delivered to the collector.

At the end of the day the book containing the original and duplicate copies, Forms A and B, is turned in at the office.

As the eggs are candled and graded the number of dozens of each grade is placed upon Form A by the grader, the same information being shown on the carbon, or Form B. This then gives the member the proper credit for the number of dozens of each grade delivered.

Settlement is made for each pool or delivery, which in most cases will be covered by one receipt for each member. As returns for the shipments are received the amount due each member will be carried out in the price and total columns of Forms A and B. Check is then drawn for the amount due and forwarded to the member with Form B, which gives a statement of returns and a duplicate of the receipt which the member holds with the additional information of the grading and amount received for each grade. Form A remains in the book and is kept on file in the office to serve as a permanent record of settlements with the producer.

FORMS

(Form A)

Folio.

No.

FARMVILLE POULTRY CIRCLE, FARMVILLE, VA.

Office copy of member's receipt

Date,, 191 .

Received of Circle No. the following:

	No.	Price	Total

Paid by check No.
Date,, 191

Checked by:
Collector

(Form B)

No.

FARMVILLE POULTRY CIRCLE, FARMVILLE, VA.

Statement of returns and copy of member's receipt

Date collected,, 191

Mr., Circle No. the inclosed check is in payment of the following:

	No.	Price	Total
Less			
Total of check			

Checked by
Collector
Manager

(Form C)

FARMVILLE POULTRY CIRCLE, FARMVILLE, VA.

No. . . .

Member's receipt

Date . . . , 191 . .

Received of , Circle No. . . . , the following

Collector

To MEMBER: Keep this receipt and compare with monthly statement sent you by Circle office.

The Candling and Grading of Eggs.—The following grading instructions are in use by the buyers of eggs for the Boston market:

Fresh Extras.—An egg to be accepted as an “extra” must be newly laid, clean, large size (minimum weight to be 45 pounds net per 30-dozen case), showing only a very small air-cell, and must have a strong, smooth shell, of even color and free from cracks. An Extra must be absolutely free from the effects of heat.

Fresh Firsts.—A “first” is an egg that is not quite nice enough for an Extra, but too good to be classified as a Second. It must be fresh laid and of medium size, and may show a small air space or may be slightly dirty. This grade must not contain very small, very dirty, or stale eggs. Minimum weight should be 42 pounds net per 30-dozen case.

Checks.—This term applies to eggs which are cracked and not leaking.

Seconds.—This term applies to eggs that are not good enough for Firsts, but of high enough quality to be used for human consumption. There are several kind of Seconds which are defined as follows:

(a) Heated egg. One in which the embryo has proceeded to a point corresponding to about eighteen to twenty-four hours of normal incubation. In the infertile egg this condition can

be recognized by the increased color of the yolk; when held before the candle it will appear heavy and slightly darker than the fertile egg.

(b) Shrunken egg. This class of eggs can be easily distinguished by the size of the air-cell. It may occupy from one-fifth to one-third of the space inside the shell. The holding of eggs for a sufficient length of time to allow a portion of the contents to evaporate is the main cause of this condition.

(c) Small egg. Any egg that will detract from the appearance of normal eggs on account of its small size will come under this class, although it may be a new laid egg.

(d) Dirty egg. Fresh eggs which have been soiled with earth, droppings, or egg contents, or badly stained by coming in contact with wet straw, hay, etc.

(e) Watery egg. Those in which the inner membrane of the air-cell is ruptured, allowing the air to escape into the contents of the egg, and thereby giving a watery or frothy appearance.

(f) Presence of foreign matter in eggs. This condition is found in many new laid eggs, and has the appearance of a small dark streak or clot of blood—often eggs are laid which show small clots about the size of a pea. These are sometimes termed “liver” or “meat” spots.

(g) Badly misshapen eggs. Eggs which are extremely long or very flat, or in which part of the shell's surface is raised in the form of a ring; in other instances a number of hard wart-like growths appear on the outside of the shell.

The following classes are to be rejected as worthless:

· *Leakers*.—As indicated by the name, this term applies to eggs which have lost a part of their contents, and eggs so badly broken that they cannot be safely transported in cases. These should be saved by breaking into cans and frozen.

Spots.—Eggs in which bacteria or mold growth has developed locally and caused the formation of a lumpy adhesion on the inside of the shell. There are three well-recognized classes of mold-spots, namely, white, brown, and black. In cases where an infertile egg has been subjected to natural heat for a sufficient time the yolk will often settle and become fixed to the membrane. This condition might be termed a “plain spot.”

Blood Rings.—Eggs in which the embryo has developed to a sufficient extent that it is quickly recognized when held before the candle. It has been found that it requires between twenty-four and thirty-six hours of incubation under a sitting hen to produce this condition.

Rots.—Eggs which are absolutely unfit for food. The different classes of rots may be defined as follows:

(a) Black rots. This is the easiest class of rots to recognize and, consequently, the best known. When the egg is held before the candle the contents have a blackish appearance, and in most cases the air-cell is very prominent. The formation of hydrogen sulphid gas in the egg causes the contents to blacken and gives rise to the characteristic rotten-egg smell, and sometimes causes the egg to explode.

(b) White rot. These eggs have a characteristic sour smell. The contents become watery, the yolk and white mixed, and the whole egg offensive to both the sight and the smell. It is also known as the "mixed rot."

(c) Spot rot. In that case the foreign growth has not contaminated the entire egg, but has remained near the point of entrance. Such eggs are readily picked out with the candle, and when broken show lumpy particles adhering to the inside of the shell. These lumps are of various colors and appearances. It is probable that spot rots are caused as much by mold as by bacteria, but for practical purposes the distinction is unnecessary.

To all intents and purposes, the spot rot, as explained above, is practically the same as the brown and black spots described under the general head of "spots." The spot rot is also placed under the general head of rots simply because some candlers will call it a spot, while others designate it as spot rot. Pink and blood rots are names which are applied to a certain class of rotten eggs, the pink rot deriving its name from the peculiar pinkish color of the contents when held before the candle. The same thing is true of the blood rot, which is bloody or red in appearance.

The causes for changes taking place in market eggs have been classified as follows:

INTERIOR FACTORS AFFECTING THE INTERIOR QUALITY OF EGGS

General conditions:

- Feed
- Physical condition
- Heredity
- Ovarian conditions
- Oviduct conditions

EXTERNAL FACTORS AFFECTING THE INTERIOR QUALITY OF EGGS

Evaporation

Temperature:

- Heating at high temperature
- Heating at incubator temperature
- Heating at low temperature
- Chilling and freezing

Moisture

Bacterial invasion

Preservation:

- Home preservation
- Commercial preservation
- Cold storage
- Freezing
- Drying

The feed is known to affect the color of the yolk, density of the albumin, odor, and flavor. The percentage of moisture, condition of shell, firmness of the albumin, and size of yolk depend upon the physical condition of the bird.

Deranged ovarian conditions bring about double-yolk eggs, blood clots, multiple-germinal disks. Derangement of the oviduct cause body heated eggs, egg within egg, yolk substitution, foreign substances within eggs, and loose shell membranes.

Atwood found that there was an appreciable difference in the weights of eggs produced at different seasons of the year. In a pen of fowls which received green feed in addition to their grain ration the average weight varied from 12.72 pounds per hundred in February to 10.07 pounds in July.

In a pen of fowls receiving no green feed the weight varied from 13.33 pounds per 100 eggs in February to 11.09 pounds in July. Economical egg production shows that liberal feeding is essential. In a test of fowls of supposed equal value three pens fed liberally laid 8,062 eggs, and the same number during the same period of time scantily fed laid only 5,144.

The following test showed that for these two lots of eggs the heaviest production was in the pullet year. Two pens of pullets fed liberally averaged 138.7 eggs each, while the same test run with yearling hens averaged only 125.6 eggs per hen.

That scanty feeding reduces the size of the egg is shown in an experiment in which the eggs, in March, from a pen liberally fed averaged 60.3 grams, while the same breed and same age hens scantily fed laid eggs averaging only 57.6 grams, or a decrease of 4.5 per cent.

HOW TO CANDLE EGGS

Eggs may be clicked together and if one is cracked it can be detected by the click or "cracked pot" sound.

The room in which eggs are candled must be dark. The egg is held in the hand in a slanting position with the large end against the opening in the candler. A rapid twist from right to left will bring into view the location of the yolk, air cell, and condition of the white. The egg should be completely turned so any mold or other spots on either side may be observed.

The Air Space.—The air space of a fresh egg is less than three-fourths inch in diameter. A full egg is a first and a shrunken egg a second. Where the membrane is broken (addled egg) there may appear bubbles, a mixture of air and albumin. Movable air cells are seen in very stale eggs when the air cell divides and moves between the two membranes.

The White.—Firmness and color are to be observed. In a fresh egg the albumin is firm and thick, and in a stale egg it is weak and thin. This latter condition occurs where the egg has been exposed to warm temperatures as in summer and by incubation. If the albumin is firm it sways but little in turning during candling; on the other hand if the albumin is thin

it sways readily and the air cell shifts sooner. A fresh egg out of the shell has an opalescent appearance and the yolk stands up. Neither of these are observed in the stale egg. A watery egg may be caused by invasion by bacteria.

The Yolk.—In a fresh egg the yolk is dimly seen before the candler. The more transparent the shell the more distinctly the yolk can be seen. Because of the thin condition of the white in a stale egg the yolk can be more plainly seen. The yolk sac weakens in a stale egg, making the yolk more and more plainly visible. In such an egg when broken into a dish the yolk is noted to flatten out. In a stale egg the yolk has a tendency to float near the shell, while in a fresh egg the yolk is more nearly centrally located. Finally the yolk in very old eggs may be noted to adhere to the shell. The color of the yolk affects the light passing through it. Thus a light-yellow yolk will reflect a pink-yellow color when held before the candler, and an orange yolk a red light.

In the commercial candling room an experienced man can candle a 30 dozen case in fifteen minutes. They work nine hours a day handling approximately 1080 dozen eggs or about 3,600,000 dozen annually.

STUDENT'S LABORATORY CHART

Testing Eggs for Home Consumption

- (1) Number the eggs before you, very lightly, with a lead-pencil. These numbers must be cleaned off later.
- (2) Estimate their size and classify as follows:

Number of Eggs

Lot No.	Large, over 2 oz.	Medium, 1¾- 2 oz.	Small, 1 ¼ or less	Totals
1				
2				
3				

(3) Candle the eggs at the candle assigned, and make a careful sketch of each egg, showing the interior appearance, including at least the yolk and the air space.

The quality should be designated by one of the following terms:

- | | |
|-----------------------------|-------------------------|
| 1. Fresh. No heat shown. | 15. Cold storage No. 2. |
| 2. Light float. | 16. Water-glass. |
| 3. Heavy float. | 17. Limed. |
| 4. Blood ring. | 18. Boiled egg. |
| 5. Infertile incubated. | 19. Blind check. |
| 6. Visible chick. | 20. Check. |
| 7. White rot. | 21. Dent. |
| 8. Mixed rot. | 22. Leaker. |
| 9. Black rot. | 23. Blood-clots. |
| 10. Evaporated or shrunken. | 24. Meat spots. |
| 11. Ruptured air-cell. | 25. Rape worms. |
| 12. Mold spot. | 26. Bloody egg. |
| 13. Grass egg. | 27. Plain dirty. |
| 14. Cold storage No. 1. | 28. Stained. |
| | 29. Smearcd. |

At the time of candling observe if the surface of the egg is glossy or dull in appearance, and note this condition in part of the space reserved for the designation of "quality" on the candling blank (page 497).

(4) Now place each egg into a dish of water, and note the relative specific gravity of the egg as it lies in the bottom of the dish. Denote this by "heavy," "medium," and "light," and place these terms also in part of the space reserved for the "quality" designations (page 497).

(5) Clean and wipe each egg, and leave them in a row arranged in the order of their numbers, so they may be readily checked with the corresponding candling blank, which should be left with them.

STUDENT'S CANDLING TEST

Student's Name.....Date.....Per cent. Fresh.....
 Place Examined.....No. Eggs in Lot.....Per cent. Loss.....

	Number of eggs in grade	Percentage of eggs in grade	Number of eggs in grade, 30 doz. basis	Price per doz.	Value of each grade	Remarks
Fresh.....				0.40		
Light floats.....				0.37		
Heavy floats.....				0.34		
Evaporated.....				0.36		
Black rots.....				loss		
White rots.....				loss		
Spot rots and molds..				0.15		
Blood-clots.....				loss		
Meat spots.....				0.25		
Blind checks.....				0.35		
Checks.....				0.29		
Leakers.....				0.15		
Miscellaneous						

CORNELL STUDENTS CANDLING CHART

Candling Quality of Eggs

(1) Do not mark the eggs, but arrange them in regular order to correspond with their record No. on this sheet.

(2) Sketch the air space, yolk, and all other interior characters.

Student's Name.....

..Date.....

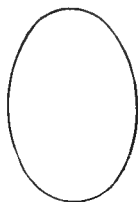
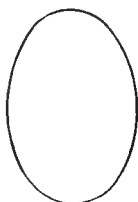
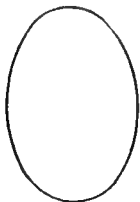

No.....

No.....

No.....

Quality.....

Quality.....

Quality.....

.....

.....

.....

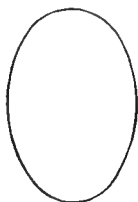
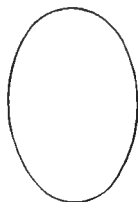
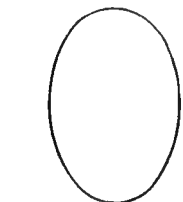

No.....

No.....

No.....

Quality.....

Quality.....

Quality.....

.....

.....

.....

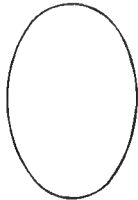
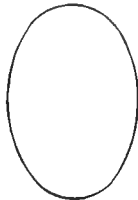
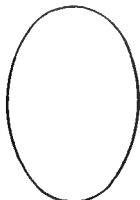

No.....

No.....

No.....

Quality.....

Quality.....

Quality.....

.....

.....

.....

THE COLOR OF EGGS FROM THE DIFFERENT BREEDS

The eggs from the Asiatics—that is, the Brahmas, Langshans and Cochins—are brown. The eggs from the Langshans are various shades of brown.

The eggs from the American class, as the Plymouth Rocks, Wyandottes, Javas, Dominiques, Rhode Island Reds, and Buck-eyes, are a brown, shading from a light to a dark color, that is, a pink, pink brown, and brown.

The eggs from the Mediterranean class, as the Leghorns, Minorcas, Spanish, Blue Andalusians, and Anconas, are white.

Eggs from the English class, as the Dorkings, Redcaps, and Orpingtons, are a light to a medium brown color, being influenced by the breeding.

The French class, as the Houdans, Crevecœurs, and La Fleche, are white.

The Continental class, as the Campines, lay a white egg.

The Games lay a brown egg; the Lakenvelders, Yokohamas, Sultans, and Silkies lay a white egg.

Geese lay a white egg, ducks white or tinted green, turkeys a speckled, and guineas a cream-colored egg.

JUDGING EGGS

Two methods are used in judging eggs, as in judging birds—that is, by comparison and score-card.

The fancy egg score-card has provisions for the following information and points: Date, exhibitor, address, variety, color, weight, entry number, size, shape, shell texture, condition of shell, uniformity of shape, uniformity of color, a space for the total points required, the total points cut, and the score. This also has provision for the signature of the judge and the secretary.

Eggs from Anconas, Brahmas, Langshans, and Minorcas must weigh 26 to 28 ounces, all other breeds 24 to 26 ounces. Three points are cut for each ounce over or under weight.

Five to 6 points are allowed for shape and for the standard; taking into consideration the whole dozen exhibited it is usual to allow 10 points.

APPEARANCE OF EGGS ON CANDLING

(South African Poultry Magazine Candling Chart)

FIT FOR FOOD

FRESH EGG

Before the Candle:

Air Space: Small; less than $\frac{3}{4}$ -inch in diameter; edges firm.

Yolk: Can be dimly seen above middle of egg; it moves slowly when egg is turned. *Chick Spot* cannot be seen.

White: Clear and firm.

Out Of Shell.

Yolk: Even in color, firm and round. *Chick Spot* small, with no sign of growth. In an infertile egg the chick spot is exceedingly small.

White: Firm and thick; flows slowly and glistens.

STALE OR SHRUNKEN EGG

Before the Candle.

Air Space: Always large. Its edges may be wavy.

Yolk: Easily seen and moves quickly when egg is turned.

White: Clear but thin.

Out of Shell.

Yolk: Flattened, sometimes mottled with deeper colored spots; easily broken. *Chick spot* either small or enlarged, and generally shrunken.

White: Watery, with very little thick white; flows freely and does not glisten like a fresh egg.

Caused by long holding after egg is laid, allowing the egg contents to dry out.

WEAK EGG

Before the Candle.

Air Space: But slightly enlarged.

Yolk: Very easily seen and near the shell. Moves quickly; may have a hatch spot.

White: Clear and thin.

Out of Shell.

Yolk: Flattened.

White: Thin and watery. This egg occurs most frequently in the summer-time. It is neither stale or shrunken.

EGG WITH SETTLED YOLK

Before the Candle.

Same as stale egg, except that yolk is in lower half of egg and moves upward when egg is turned before the candle.

Out of Shell.

Same as stale egg.

Caused by long holding.

HATCH SPOT EGG

Before the Candle.

Air space is either large or small.

Yolk is easily seen with a reddish glow or spot on its upper surface. No blood be seen.

Out of Shell.

Chick spot shows signs of development, but no blood.

Cause: ONE RESULT OF A FERTILE EGG.

EGG WITH OLIVE YOLK

Before Candle and out of Shell.

Yolk appears dark brown or olive.

Cause: Not definitely known; may be due to feed of hen.

EGG WITH MOVABLE CELL

Before the Candle.

Air space moves as egg is turned; when composed of small

bubbles, indicates egg membrane broken and air mixed with white.

Out of Shell.

May be any kind of egg, good or bad. Edible, if good; inedible, if bad.

Caused by either long holding or rough handling.

UNFIT FOR FOOD

EGG WITH BLOOD RING

Before the Candle.

Bloody veins, or a whole or partial ring of blood, can be seen on the yolk; sometimes shadow of yolk is shaped like a new moon.

Out of Shell.

Blood is seen on yolk, due to developing chick; a later stage than the hatch spot.

Caused by development of embryo in fertile egg.

Take the Rooster away! Unfertile eggs cannot form Blood Rings.

EGG WITH STUCK YOLK

Before the Candle.

Yolk has stuck to shell.

Out of Shell.

Yolk breaks with a portion sticking to shell.

Caused by yolk in stale eggs rising or settling and sticking to shell.

MOULDY EGG

Before the Candle.

Black patches or spots show on inside of shell. They cannot be seen without candling.

Out of Shell.

Patches of mould are seen on inside of shell or through the egg.

Caused by damp nests, washing or holding in damp place, thus allowing mould to enter shell.

BLACK ROT

Before the Candle.

Contents mixed and muddy or black.

Out of Shell.

Yolk and white mixed—grayish-yellow in color; stinks.

Caused by death of embryo, or mould and decomposition.

MIXED ROT, WHITE ROT, OR ADDDLED EGG

Before the Candle.

Yolk and white mixed; yellowish color; portion of yolk may sometimes be seen. In advanced stages the yolk outline is entirely gone. It is difficult to distinguish this egg from a fresh egg.

Out of Shell.

Yolk and white mixed; light yellow color. Sometimes sour odor.

Caused by bacterial decomposition or breaking of yolk and white in stale egg.

EGG WITH BLOODY WHITE

Before the Candle.

General bloody or brown appearance of egg, indicating blood mixed in white.

Out of Shell.

Red or brown blood mixed or diffused in white.

Caused by rupture of ovary or oviduct, allowing blood to enter egg during its formation.

EGG CONTAINING BLOOD SPOTS OR OTHER FOREIGN BODIES

Before the Candle.

Dark spots are seen floating in white or attached to yolk. They must not be confused with the white cords that hold the yolk.

Out of Shell.

Clots of blood, flesh, grain or even worm or feces or gravel may be against the yolk or floating in white.

If the particles of blood or flesh

are small, the egg is generally considered edible on removal of such bodies.

Caused by rupture of ovary or oviduct or the inclusion of foreign matter during the formation of the egg white.

In texture the shell must be free from wrinkles, cracks, weak spots, or rough places; $1\frac{1}{8}$ points are allowed for each egg.

As to condition, the eggs must be unwashed and free from stain or dirt of any kind. To secure this, the eggs must be laid



FIG. 202.—Purdue University. 1915 egg contest.

in a clean nest and the feet of the bird must not be wet or muddy.

Since small or large eggs are not classed as first-class eggs, they must be of uniform size.

The eggs must be of uniform shape, which is governed to some extent by the breed.

The color must be uniform. Since some varieties lay eggs of different shades, this will require careful selection of the eggs for exhibition. If the variety lays a brown egg, as the Rocks, the color may be of any shade, from a pink to a pink brown to a

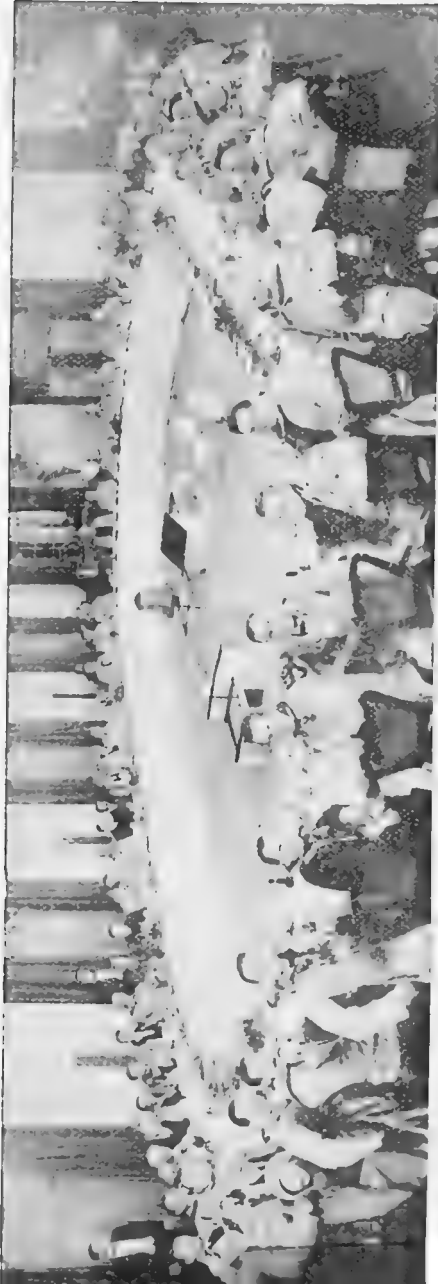

FIG. 203. - Poultrymen at a unique banquet at the Biltmore Hotel, New York City, November, 1914.

brown, but all of the eggs exhibited should be of the same shade.

As to disqualifications, we may consider cracks or checks, dents, leakers, spotted, musty, rotten, and blood rings. The latter occurring in one egg of a lot is considered sufficient to disqualify the entire lot.

The relative points allowed in the score-card for commercial eggs are as follows: Shape, 3 points; size, 25 points; uniformity of color, 4 points; uniformity of size and shape, 5 points; shell texture, 8 points; quality, 25 points (shown by the size of the air-cell); opaqueness, 25 points; condition of shell, 5 points. Total, 100 possible points.

The relative points allowed in the score-card for fancy eggs is as follows: Uniformity of color, 10 points; uniformity of shape, 5 points; uniformity of size, 15 points; size, 40 points; shape, 10 points; shell texture, 15 points; condition of shell, 5 points.

CHAPTER XXVI

CASTRATION OF THE BIRD (CAPONIZING)

THERE are great possibilities in the more extended practice of capon production. The fact that there is a growing demand, as their value as a superior meat product over the cock or cockerel, and the fact that they bring about thirty cents a pound, while the uncastrated bird brings only about fifteen cents, together with the fact that they become very much larger, makes this phase of poultry husbandry a productive and remunerative one.

The male bird, after the removal of his reproductive organs, loses his masculine appearance, becomes sluggish, and, as a result of his inactivities, gains weight rapidly.

From the loss of that internal secretion manufactured in the testes we note that there is the same difference which is observed in other animals under the same treatment. The development of the gelding, as compared to the horse, and the barrow, as compared to the boar, are some concrete examples.

Ovariectomy results in the assumption of male characters by the operated female.

It was noted that in some capons kept several years, the comb and wattles began to grow, after eighteen months of age, eventually reaching a large size. These birds crow and exhibit sexual relations.

Castrated drakes assume the plumage of the normal male. The castrated drake does not assume the summer plumage, although molting frequently always retain the so-called breeding plumage. The ovariectomized duck assumes male characteristics.

The spayed pullet appears much like a capon but has short legs. The comb and wattles may become relatively large.

It appears that while both testes and ovaries develop an internal secretion, yet their effect is quite different.

The same improvement in meat is noted in the castrated or caponized bird as in the steer over the meat of the bull, or the meat of the barrow superior to that of the boar. Hence, capon raising is highly desirable, and if properly managed is a profitable undertaking.

A capon of the Plymouth Rock, Wyandotte, or Rhode Island Red breed should weigh fully 7 or 8 pounds when eight months old.

Light capons are produced from the Rocks, Wyandottes, and Reds, while the heavy capons are produced from the Brahmas and Cochins.

The cockerel should be caponized when he weighs from 1 to $1\frac{1}{2}$ pounds, which will probably be when he is about eight to ten weeks old.

If the birds are allowed to become too old before operation the testes are found to be very large, the removal of which may prove fatal to the bird. If the birds are hatched from March to May, the operation should be performed in the months of June to September, and with proper feeding and care these birds should then be ready to market from December to March.

The equipment needed to perform this operation is a table provided with means of confining the bird, and instruments, consisting of a knife or scalpel, with which to make the incision or cut through the abdominal wall, a hook for tearing through the peritoneum or lining of the abdominal cavity, air-sac walls, and at times through the mesentery, and a spreader for holding the wound open while the removal of the testes is accomplished.

An improvised table may be made by taking a barrel, using two strings and two weights of sufficient size to hold the bird down, usually about the size of a half-brick. The strings are doubled, and one looped around the legs, the other around the base of the wings, and half-bricks tied to the free ends, as shown in Fig. 204.

A poultry operating-table has been designed by the writer, as shown in Fig. 205. It consists of a top 2 feet wide and 30 inches long. This table is provided with 4-inch cross-pieces, as shown, and are located about half-way from the top of the table to the ground, and provided with two awning hooks on either side. Holes are bored through the top at suitable loca-

tions. The loop of the string is run through the hole on its respective side and over the leg or base of the wings, and the legs and wings drawn snugly down to the top, and the free end of the strings wrapped around the hooks and given a half-hitch.

If the bird or birds are to be operated on in the forenoon no feed should be given on the previous day. It is also well to withhold water, as an abundance of water causes more hemorrhage, owing to the increased amount of liquid in the body

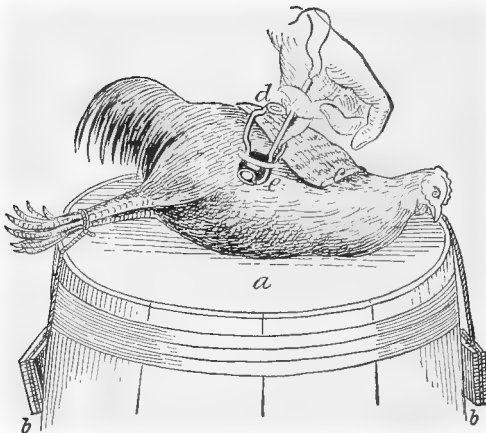

FIG. 204.—An improvised operating-table for caponizing: *a*, Top of barrel; *b*, weights to hold down the bird; *c*, cord looped around the legs and wings; *d*, the spreaders holding the wound open; *e*, cannula for removing the testes.

tissues. It is rather difficult to accurately and satisfactorily operate when the intestines are gorged with food.

The operation is best performed in the bright sunlight unless the operator is provided with a head reflector.

The instruments should be kept in a shallow pan of antiseptic, as creolin, or, better, formaldehyd solution. A small amount of absorbent cotton should also be at hand. After the bird is confined pluck a few feathers over the field of operation, which is between the last two ribs. It is well to place a small chunk of ice in the pan of antiseptic and use the ice-water

in sponging the field of operation. The cold water thus acts as an antiseptic, as well as causing a contraction of the capillaries of the region, and less hemorrhage result.

When ready to make the incision, pull the skin over so that after the incision is made and the skin released the wound into the abdominal cavity will be closed. In making the incision

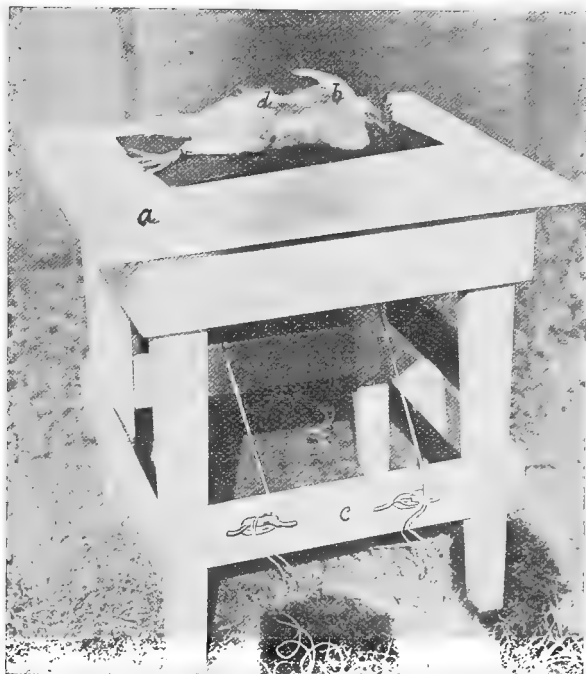

FIG. 205. —A scientific operating-table: *a*, The table top; *b*, cord looped around the legs and wings; *c*, two awning hooks, around which the cord is secured; *d*, the incision preparatory to removal of the testes.

through the skin the bird will struggle, on account of the fact that the skin is endowed with tactile or sensory nerve terminals, as is the case with all animals. The muscular and areolar tissue is not so sensitive. After this incision is made the bird will struggle very little. The knife or scalpel should be sharp and the incision made quickly. The upper point of the incision

should be about $\frac{1}{2}$ inch from the center of the backbone or vertebra. The incision should be about 1 inch long. As a nerve, artery, and vein pass along the posterior border of each rib it is necessary to not cut close to the posterior border, but make the incision close to the anterior border of the last rib.

A second incision is now made in the same wound, this time cutting through the abdominal muscles. Care must be exercised not to cut too deep and injure the internal organs. If the peritoneum (the thin and rather glistening tissue lining the abdominal cavity) is not cut, this can be broken through by aid of the hook and the spreaders inserted. Now tear

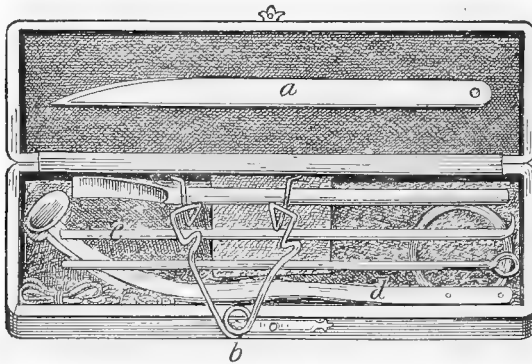

FIG. 206.—A set of caaponizing instruments: *a*, The knife; *b*, the spreaders; *c*, the hook for tearing the peritoneum; *d*, the instrument for removing the testes.

through the walls of the air-sac and push the intestines to one side and the top testis will be in plain view. The testis will appear bean shaped, about $\frac{1}{2}$ inch long and yellowish white in color. It lays up close to and is attached by connective tissue to the body of the vertebra and large abdominal blood-vessels. If it is the desire to remove both testes through the one opening, it is necessary to tear through the mesentery or web-like membrane supporting the viscera, care being taken not to make the opening too close to its attachment to the backbone or vertebra, or fatal hemorrhage may take place as a result of rupturing these delicate vessels.

If the opening has been properly made the lower testis will be in plain view. Always remove the lower one first, for if the upper one be removed first there may be some hemorrhage take place that will make it very hard to find the lower one later. For beginners it is better to operate from both sides, each time removing the upper one.

The testicular tissue is very soft, and it is necessary to use great care to remove all of the tissue. If it is crushed it will be very difficult to successfully remove it, so that it is necessary that the operation be done with skill. If care is not used, often the end of a testis will break off, and this part remaining makes a slip. This small particle will furnish some internal secretion, and the bird can neither be regarded as a cockerel or as a capon. Slips are undesirable. The accidents may be as follows: On account of the testes laying close to the vertebra or backbone, in close proximity to the abdominal aorta and other large vessels, and that the capsule of the testis is attached to them, too much traction, or improperly applying the tractors, may result in rupture of the vessel and fatal hemorrhage occur at once. If the abdominal aorta is ruptured there will be noted a hissing sound, and the bird becomes pale in the face and comb and immediately collapses. In this case cut off the head and the bird can be used for food. If the bird is allowed to struggle after the operation, a large vessel already injured by the operation may rupture and fatal hemorrhage result.

After the operation, if the incision has been properly made, no suture is necessary, but if the opening in the abdominal wall be large it is well to take one or two sutures with clean sterile cotton or silk thread.

After the operation is completed remove the birds as carefully as possible, and quietly place in a clean coop or run bedded down with clean straw. Often a struggle at this time proves fatal. Do not allow them in coops or enclosures where they can jump upon boxes, perches, or fly, as they must be kept down on the floor for a few days.

Supply the birds with clean, fresh water, and give them ground feed mixed with milk as soon as they are placed in their runs. They do not apparently suffer any inconvenience

from the operation, and will eat heartily immediately after the operation.

On the third day examine each bird to make sure there are no "wind-puffs" or emphysematous conditions—that is, air worked under the skin from the edge of the wound or incision. If wind-puffs or emphysema is present, puncture with clean sterile sharp knife or pin and allow the air to escape. Birds have a great resistance against germs of the ordinary wound infection, as the pus-producing organisms, as staphylococci and streptococci, and fatalities from this cause are very rare, if at all.

The wound should be entirely healed in three weeks' time.

SPAYING THE HEN

An unsexed (spayed) pullet is called a poulard. Spayed pullets make more rapid growth without the handicap of egg production at a later stage, and the meat is of improved quality and flavor. The spayed pullet takes on some of the appearance of a cockerel. The poulard, like the capon, becomes an outcast and is never known to cackle.

The pullets are usually operated upon at about the same age as in caponizing the cockerel, and usually in the late spring or early summer. The pullets are prepared in the same manner as cockerels for caponizing. The incision is made in a similar manner as in the cockerel, and the undeveloped egg cluster is found in a similar location in the pullet as the testicles in the cockerel. With a pair of artery forceps grasp the undeveloped oviduct, which will be found to be about the size of a broom straw, and remove about 1 inch of this and the cluster of eggs. Care must be taken not to cut or rupture any of the large abdominal blood-vessels laying just back of the ovary and against the vertebra (a similar precaution as in caponizing). The removal of the ovary and a section of the oviduct prevents the formation of eggs or the further development of the egg canal and functioning of the cells of the canal.

The after-treatment is the same as for capons.

CHAPTER XXVII

PREPARING BIRDS FOR THE SHOW-ROOM

BIRDS to be prepared for the show-room should be selected three months before the time for the exhibition, and placed in coops similar in structure to those used for exhibition coops in



FIG. 207.—A shipping crate for pure-bred birds.

the show-room. For the larger breeds these are 30 inches high, 2 feet deep, and, better, 4 feet long, and the birds are handled daily to become accustomed to it. Pull out the broken feathers that better ones may grow in their place. It is the desire to

have a bird that does not fight and flutter with fright when he is approached. It is essential that he offer no resistance to a stranger in approaching and picking him up.

Birds for show purposes are taught to pose in proper fashion much as horses are taught to pose in the show ring. A bird that is a good poser will stand a better chance of winning than one that is frightened half out of his wits when some one approaches to pick him up, for the judge who is to decide quality is a stranger to him.

Exhibition birds are usually early birds—that is, those hatched in January and February—so they may grow to maturity and possess the proper weight by the time of the fall shows.

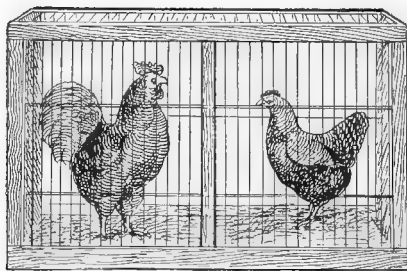

FIG. 208.—An exhibition coop.

Male birds require proper training, as stated above, so that they will present the proper appearance as to carriage and symmetry.

During the training period each male is kept separate. It is essential to see that they have no opportunity to injure themselves by tearing their face, comb, or wattles, and they must be free from vermin, as mites and lice.

Show birds shut up are fed once daily, usually in the evening; they are given all they wish to eat. The feed should consist of wheat, oats, cracked corn, and sunflower seed. They are watered at 9 A. M. and 1 P. M.

Some litter, as clean straw, should be kept in their coops.

If their legs are not in good condition, oil them every two weeks with sweet oil.

All yellow legged varieties intended for exhibition purposes should have their legs thoroughly soaked in warm water once or twice a week, using a soft nail brush and soap to get off all dirt. When the legs have dried rub in a small quantity of sweet oil and polish with a woolen cloth. A tablespoonful of borax added to the water aids in bringing out the shades.

To obtain white ear-lobes keep birds in a darkened pen and apply to the ear-lobes each day a small quantity of zinc ointment. Afterward dust with violet powder.

If the birds become dull and constipated, give each bird one tablespoonful of castor oil.

Birds for exhibition must conform to the "American Standard of Perfection" in every way and not possess any of the disqualifications.

Birds for the show-room should be washed. The room in which birds are washed should be over 80° F. Three wash-tubs are convenient receptacles in which to wash them. The water in each should be about 110° F. The bird is immersed in the first tub with only the head out of the water, lather thoroughly with white soap, rubbing the way the feathers lay. With nailbrush lightly scrub; it is necessary to avoid rubbing against the feathers, or crosswise of the feathers, or ruffle, or in any way break the feathers. Rinse thoroughly with two rinse waters. The soap must be thoroughly rinsed out of the feathers or they will not thoroughly fluff out after drying. In white plumage birds often a small amount of laundry bluing is added to make the feathers whiter, but care must be taken not to use too much as injury may be done. White ear-lobes may be tinged blue, as well as streaking of the plumage. After rinsing thoroughly dry with a towel, using it by sopping and patting the bird. Often absorbing paper-towel material gives good results. Do not rub the feathers, as injury may result. In some experiments, conducted in the laboratory of the author, it was found by having one of the tubs of water at 80° F. that by passing the birds through in a space of five minutes the body temperature would fall 3° to 5° F. below normal, which would upset the normal thermic equilibrium of the bird if then placed in a room too cool. In a room at a temperature of 60° F. the birds shivered and apparently suffered from exposure. It

would appear, from a physiologic standpoint, that it would be better to place the birds in wash and rinse water at a temperature near that of the body and then have the drying room at a temperature of approximately 100° F. The normal temperature of an adult fowl is about 106° to 107° F. The room temperature should be gradually brought down to about 70° F. as the birds dry.

In shipping, regulation exhibition coops should be used. These are substantially built coops, with sufficient capacity so the feathers of the birds do not become ruffled or damaged and the comb does not touch the top of the coop. (See Fig. 207.)

Do not put water in the coop, as it will result in soiled plumage. Place an apple or potato in the coop for them to pick at, it will give them some succulence.

For requirements of the different standard breeds reference should be made to the "American Standard of Perfection."

Saturated carbonate of iron has been fed to birds of buff and yellow varieties to improve the depth of color. This must be fed at time of molting.

Birds which should have white ear-lobes often develop red in them. To make the ear-lobes white Cobb recommends the following: wash them in milk, and dry thoroughly, then apply powdered oxide of zinc.

Peroxide of hydrogen bath is sometimes used to make the white plumage pure white and to overcome brassiness.

Dirt from the legs and nails is removed by scrubbing with a nail brush during the bathing process.

The feeding of linseed meal and sunflower seed improves the gloss of the plumage.

GROWING SHOW BIRDS

In rearing show birds special care should be given to the care and feed as they grow and develop. When the birds are about five months old the adult plumage begins to develop. At this age the birds should be carefully shielded from the sun's rays. This can be done by keeping them in the house during a part of the day and allowing them to go out into the

pen after the sun is off the pen. This shade is, in large measure, the secret of success. Give a roomy shed in which to exercise, or a small exhibition pen which can be moved to fresh grass every two or three days.

Hooley recommends that the buff and black fowls be given cracked corn and corn meal as part of the ration, Hamburgs and bantams hemp and buckwheat seed. Game fowls should be fed entirely on grain diet. This grain diet may consist of 1 part peas, 3 parts wheat, and 3 parts oats. Peas produce a hardness of the feathers. Meat, cut bone, and peas are rich in albuminous food, and promote large fleshy combs, and therefore should be fed very sparingly in small-combed breeds.

The plumage of fowls is affected by the feeding. Corn, both whole and cracked, can be given to buffs, as it perhaps affects both legs and plumage. Do not give corn to exhibition white plumage birds. Those feeds which darken the plumage, increase the gloss, help the sheen and luster of feathers and promote length of feather, and increase the intensity of yellow legs are corn, cracked corn and corn meal, hemp seed, cottonseed, and linseed meal, meat and cut bone. Those which have a bleaching effect on the skin and can be given to pure white plumage birds are oats, oat meal, middlings, sunflower seed, barley, wheat, and pea meal.

Handling the Fowl.—In taking the bird from the cage, the hand should be placed over the back and the right wing grasped. The left hand takes the opposite side with the thumbs crossed meeting across the back, and with the fingers under the breast, the bird is carefully lifted from the cage.

CHAPTER XXVIII

THE CONSTRUCTION OF POULTRY HOUSE EQUIPMENT

THE CONSTRUCTION OF A DRY MASH HOPPER

FIGURE 209 illustrates one of the most useful pieces of poultry house equipment—namely, the dry mash hopper. It can be built of $\frac{7}{8}$ -inch yellow pine boxing boards.

From the illustration it will be noted to be 29 inches high at the back and 18 inches wide at the bottom. A convenient length is 4 feet. Partitions are so placed that there will be a 4-inch compartment for shell, a 4-inch compartment for charcoal, a 4-inch compartment for grit, and the balance for the dry mash. The lid at the top is sloped so that the chickens cannot roost upon the box. The front wall is placed at an angle so that the bottom end is only 8 inches from the back. At the top it is 14 inches. A strip is placed in the back angle so that the mash feeds down well. The lift-up lid should be at least 12 inches wide, so as to make an opening large enough to empty the mash in with ease. A 4-inch strip is nailed to the feed opening in such a manner that a lip of about 2 inches projects into the hopper and makes it more difficult for the birds to throw the feed out with their beaks. One-quarter inch round wire bars are placed every 4 inches the entire length of the hopper, which aids in keeping the hens from throwing the feed out. A lid 4 inches wide is placed over the 4-inch opening where the birds feed. This is kept down at nights to prevent the rats and mice from eating the feed. (Refer to Fig. 106 for the front view of this hopper.)

Breeding hens should be given their mash every afternoon, and for laying hens both forenoon and afternoon.

A storage box for morning and afternoon scratch feed is also shown in Fig. 106. It is 4 feet long, 12 inches wide, 15 inches

high in front, and about 30 inches in the rear, which gives a steep slope to the top and makes it impossible for hens to roost on it. By keeping a supply of the feed in the hen house much valuable time is saved.

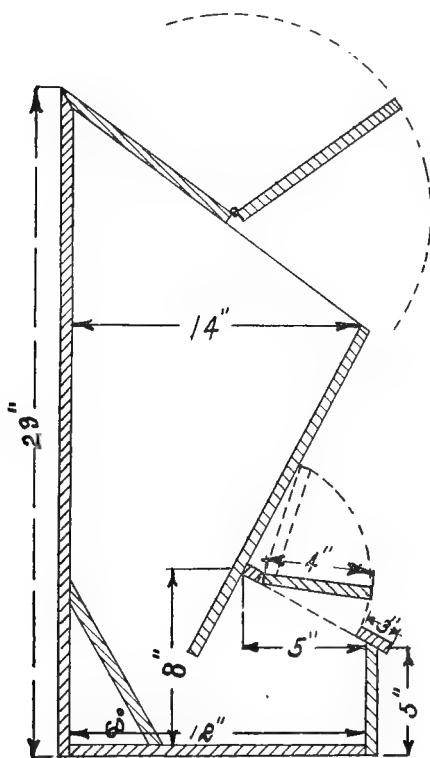

FIG. 209. —The indoor feed hopper.

THE CONSTRUCTION OF A TRAP-NEST

There are many kinds of trap-nests. The following drawings and photograph were made from trap-nests in use at the North Carolina Experiment Station. A trap-nest should be simple, not being easy to get out of order, and at the same time

durable. It is estimated that there should be one nest for each four hens.

Figure 210 gives a sectional view of Fig. 212, the trap-nests that are in use at the North Carolina Experiment Station. It

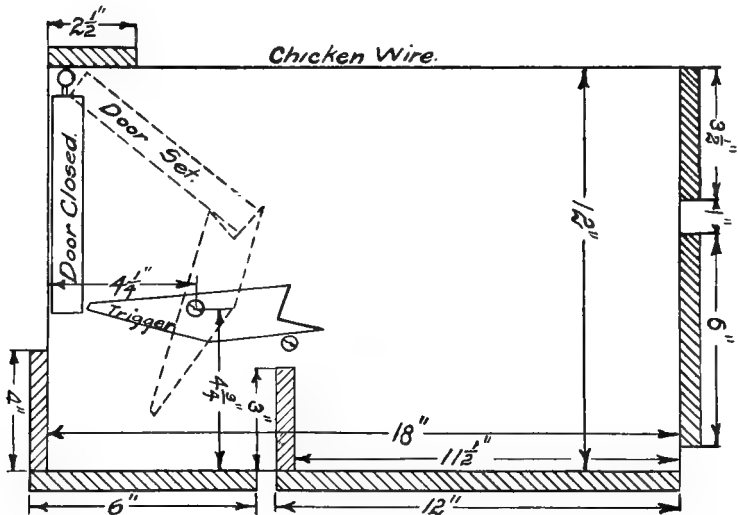

FIG. 210.—Side sectional view of a trap-nest.

is 12 inches wide, 18 inches long, and 12 inches high, inside measurements. The top is made of chicken netting, so that it is not too hot in the summer time, ensuring plenty of ventila-

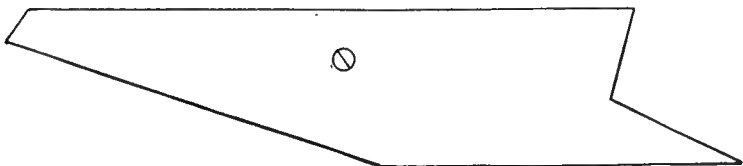

FIG. 211.—The trigger for the trap-nest.

tion. The compartment the nest is located in is $11\frac{1}{2}$ inches long. In front of this is a 3-inch strip which holds the nest material in. The front piece is a 4-inch strip, which leaves

6 inches between the nest and the door, ensuring that the hen does not break the egg should she struggle to get out. A 1-inch opening in the back partition gives ventilation and an inch space in the bottom allows the filth to drop out on the floor. The trigger holds the door open, which, when released, keeps



FIG. 212.—The front view of the trap-nest in use: a, A trap-nest set; b, trap-nest sprung, containing hens on the nests; c, the dropping board; d, the roost; e, scratch litter on the floor in which scratch feed is thrown.

it closed. The dotted lines indicate the door up or set and the position of the trigger. By again referring to Fig. 212, the front view set and closed can be observed. When the door is closed there should be about $\frac{1}{2}$ inch space on the side of the door, so that a lead pencil can be gotten in to release the

trigger, and this same pencil is then used to mark the date and leg-band number on the small end of the egg. The record sheet is shown in Fig. 216.

Nests require an abundance of ventilation in hot weather. The bottom of the trap nests may be covered with $\frac{1}{4}$ or $\frac{1}{2}$ inch square mesh wire gauze.

In taking the hen from the nest stand directly in front of the nest, and allow the hen to come out directly in both hands in such a way that you grasp the wings and body, and by gently talking to them they soon become accustomed to trap-nest methods and do not appear frightened. Laying hens must be carefully handled, as their physiologic equilibrium is easily upset and egg production interfered with. One person should visit the trap-nests alone, and he should be a person that likes the work and takes an interest in it, and is, above all, kind and gentle with the hens.

The trap-nests should be visited at about 7 A. M. when the scratch feed is given; again at 9 A. M., when water is given; again at 10 A. M. when succulent feed is given, and again at 12 M. and at 1 P. M., 2 P. M., and at 3 P. M., when the evening scratch feed is given. The bulk of the laying is done between the hours of 11 A. M. and 3 P. M.

LIST OF MATERIAL FOR NESTS

- 1 board 1" \times 14" \times 8' (for partitions).
- 1 board 1" \times 8" \times 7' (for door).
- 3 boards 1" \times 4" \times 7' (for bottom, front and back and run-board or step).
- 2 boards 1" \times 2" \times 7' (to nail netting to).
- 2 pair strap hinges 8" long.

The nests are constructed with the inside compartments 14 inches square. Nests for the Mediterranean breeds such as the Leghorns may be 12 inches square; for the American breeds, as the Plymouth Rocks, 14 inches square; and for the Asiatics, as the Brahmas, the nest should be 16 inches square.

The top and bottom is provided with a strip 2 inches wide extending around the outer border to which $\frac{1}{4}$ inch mesh wire netting is stapled in the front. The opening is covered

with a board eight inches wide and is hinged at the bottom and hooked above so that by letting down this door the nests may be gotten to. The bottom strip to which this is hinged is 4 inches wide and a strip along the top border 2 inches wide to which the door is hooked. There is a strip 4 inches wide in the back and at the lower portion of the nests which retains the nesting material. A runboard or step 4 inches wide

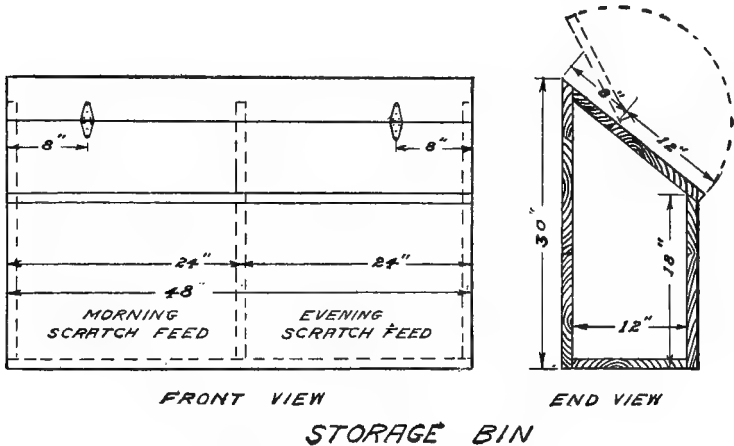

FIG. 213.—A grain storage bin.

and extending along the entire length furnishes a step for the birds to hop upon in entering the nests. This strip is held in position by a cleat, and a space 2 inches wide is provided between the step and nests. The partitions are located 14 inches apart, making six nests (see Fig. 215).

LIST OF MATERIALS FOR THE STORAGE BIN

- 2 boards 1" × 12" × 14'.
- 1 board 1" × 6" × 12'.
- 1 pair strap hinges 8" long.

The back is 30 inches high and the front 18 inches. The bin is 12 inches wide and 4 feet long with a partition in the center dividing the bin into two chambers, one for the morning

scratch feed and the other for the evening scratch feed. The steep angle at the top prevents the birds from roosting on the top (see Fig. 213).

SCRAPE AND BOX FOR DROPPINGS

The dropping box is 16 inches wide, 24 inches long and eleven inches deep. It is provided with a handle. The scrape is $3\frac{1}{2}$ inches wide and 18 inches long with a 30-inch handle.

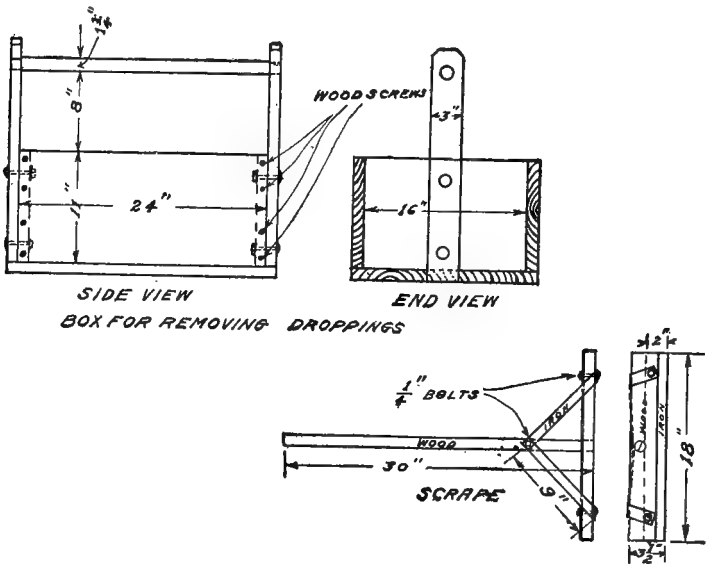

Fig. 214.—Dropping box and dropping board scrape.

The scrape is provided with a metal scraping edge (see Fig. 214).

THE CONSTRUCTION OF THE COMBINATION SITTING AND BROODING COOP

LIST OF MATERIALS

- 1 bunch plaster lath (for run).
- 2 boards $1'' \times 8'' \times 12'$ (for bottom sides and back).

- 6 pieces 2" × 2" × 12' (for framing for run and house).
- 1 piece of rubberoid 3½' square.
- 3 hinges 4" long.

The roof is a shed-like structure so made that the 2-inch by 2-inch framing material fits over the building like a hood. The back of the building is 18 inches high and the front is 2

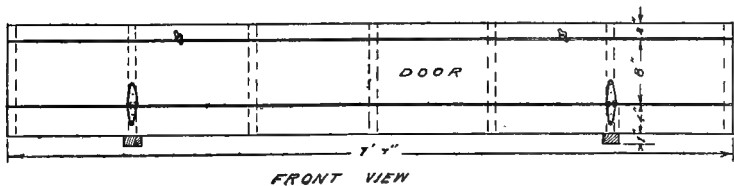
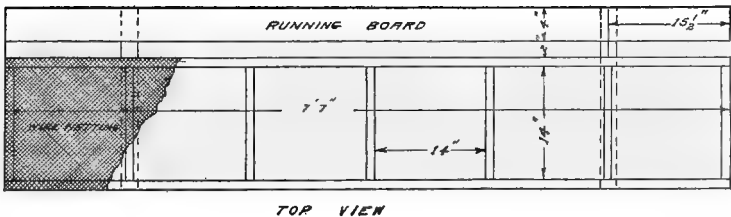
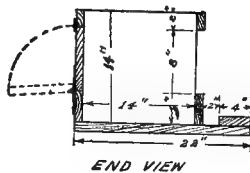

FIG. 215.—The construction of hen's nests.

feet. The floor area is 2 feet square. A removable bottom is constructed of three 8-inch boards which should be tongued and grooved. Notches are cut out so that the floor boards fit around the frame. This floor is used in the winter and

early spring when the ground is cold and wet. Later, it is dispensed with and the hen is set on the ground. Her young are brooded on the ground later on. The area on which the coop rests should be slightly higher than the surrounding ground to insure the dirt floor being dry. The top of the coop is covered with rubberoid or other equally good roofing material. The front is slatted with one slat removable and slat hinged at the middle so that it may be placed without removing the top. To keep out rats and other nocturnal animals, a frame is made 2 feet square on which is tacked $\frac{1}{4}$ -inch mesh wire netting. This netting frame is placed in front of the house at night and allows of an abundance of air, yet at the same time protects the brood. A door, 8 inches wide and hinged at the bottom, is constructed at the side of the coop and gives ready access to the interior of the coop without removal of the top. The extension run is 4 feet or the length of the plaster lath. The framing material on which the laths are nailed is made of 2-inch by 2-inch material. A door is constructed at the top and hinged with two small hinges. The run is divided into two compartments, the one for the hen a little larger than the other one. The hen is allowed her run while sitting and while brooding. The baby chicks may be fed in their own compartment where they are not molested, and the hen is fed a cheaper feed consisting of grain. The slats are arranged 2 inches apart which allows the chicks to enter but keeps out the larger birds (see Fig. 148).

NORTH CAROLINA AGRICULTURAL EXPERIMENT STATION									
WEEKLY PEN RECORD									
PROJECT NO. _____		MONTH _____		FROM _____		TO _____			
PEN NO. _____		BREED _____		NO FEMALES _____		AGE OF FEMALES _____		NO OF MALES _____	
TYPE	DAY	MORNING	NIGHT	OTHER	SUPPLEMENT	EGGS	HENS		
BLAND				FEED	FEED				
1								DRY MASH	
2								Kept	Weight
3									Cost
4									
5									
6									
7									
8									
9									
10									
11								MORNING FEED	
12								Kept	Weight
13									Cost
14									
15									
16									
17									
18								NIGHT FEED	
19								Kept	Weight
20									Cost
21									
22									
23									
24								OTHER FEED	
25								Kept	Weight
26									Cost
27									
28									
29									
30									
31								Total hours labor	Cost
Total								Total amount feed consumed	
								Total number eggs	
								Average millie. nitro. per dozen	

FIG. 217.—A weekly pen-record sheet.

NORTH CAROLINA AGRICULTURAL EXPERIMENT STATION—INCUBATOR RECORD											
INCUBATOR	EGGS IN					TESTED					
DAY	1	2	3	4	5	6	7	8	9	10	
Morning Temp.											
Noon Temp.											
Night Temp.											
NOTES:											
DAY											
11	12	13	14	15	16	17	18	19	20	21	
REMARKS:											
Eggs Broken						Chicks Hatched					
Infertile Eggs						% Eggs Hatched					
Hatch Due						Hatch Out					
						Died in Shell					

FIG. 218.—An incubator record card.

NORTH CAROLINA AGRICULTURAL EXPERIMENT STATION—BROODER RECORD																						
BROODER	STARTED											FROM INCUBATOR										
DAY	1	2	3	4	5	6	7	8	9	10	11	12	13	14	15	16	17	18	19	20	21	22
A. M. Temp.																						
P. M. Temp.																						
Dead																						
Desired Temp.	110°					96°					92°					88°						
DAY	23	24	25	26	27	28	29	30	31	32	33	34	35	36	37	38	39	40	41	42	43	44
Dead																						
Total Chicks in	Total Survivors											% Reared										
Total deaths																						
Chicks moved to another place												When and Why?										
Feed—																						

FIG. 219.—A brooder record card.

NORTH CAROLINA AGRICULTURAL EXPERIMENT STATION																																				
VARIETY											EGG RECORD															BIRD No.										
HATCHED											HOUSE No.					YARD No.					PEN No.					REMARKS										
DATE	1	2	3	4	5	6	7	8	9	10	11	12	13	14	15	16	17	18	19	20	21	22	23	24	25		26	27	28	29	30	31				
Jan.																																				
Feb.																																				
Mar.																																				
Apr.																																				
May																																				
June																																				
July																																				
Aug.																																				
Sept.																																				
Oct.																																				
Nov.																																				
Dec.																																				

OVER

FIG. 220.—An individual egg-record card.

TOTALS					
DATE	LAID	INFERTILE	DEAD IN SHELL	INFECTED	HATCHED
Jan.					
Feb.					
Mar.					
Apr.					
May					
June					
July					
Aug.					
Sept.					
Oct.					
Nov.					
Dec.					

OVER

FIG. 221.—The back ruling of card of Fig. 220.

NORTH CAROLINA AGRICULTURAL EXPERIMENT STATION—ANIMAL INDUSTRY DIVISION	
POULTRY EXPERIMENTS AND PATHOLOGY	
SALES MEMORANDUM	
DATE.....	
To { HEAD OF DEPARTMENT OR PURCHASING AGENT.....	
NO. BIRDS SOLD ALIVE.....	PRICE.....
NO. BIRDS SOLD DRESSED.....	PRICE.....
NO. EGGS SOLD.....	PRICE.....
PURCHASER.....	
FOREMAN.	

FIG. 222.—A convenient sales memorandum.

PRACTICAL POULTRY ACCOUNTANT WORK

Four factors are essential to poultry success. These are, birds to lay, large numbers of birds, sufficient capital, and sufficient experience. The following poultry accountant work is an essential to the success of poultry work. One must keep accurate business accounts to know of the degree of success. On the average farm it requires approximately 9 pounds of feed and 0.21 hours labor to produce one dozen eggs. The cost of this 9 pounds of feed and 0.21 hours labor will constitute three-fourths of the total cost of the dozen eggs under efficient management.

Flock Record, Pen Sheet; Page 1.—The hens should, if possible be counted the first of each month to check with the figure obtained in the records by adding and subtracting the hens added and removed respectively. The date of counting and the number should be recorded in the last column.

The males are not to be considered with the records of the number of hens in the flock, or the number removed or added; the only item to be recorded for the males is the number held for breeders or for sale as breeders, when counted each month, to be recorded in the last column of this sheet under "males."

Egg Record; Page 2.—The number of eggs gathered should be recorded daily.

Poultry Debits; Pages 3-9.—All items of expense or anything received by the poultry such as birds purchased or received as gifts, and feed, etc., should be recorded daily when the business is done; do not wait until payment is made. The number of pounds of feed and values of same should be entered in the separate columns so designated; all else should be entered in the Misc. column, unless it is desired to separate some other class of items such as cost of constructing certain buildings, cost of rearing chicks, etc., when the middle column may be so marked and used.

The estimated value of all labor besides the operator's, including horse and man labor, whether actually hired or donated, should be entered at least monthly. Do this regularly so it will not be forgotten.

A simple method of recording the settlement of accounts with outside persons is to place a check (✓) just after the item when settlement has been made. In this way one can easily see if all transactions with any particular party have been settled.

Poultry Credits; Page 6.—Entries should be made daily when the transactions occur. All transactions in which the poultry produces something of value, should be noted here, such as eggs sold, used at home, or given away; feathers sold, etc. The values and number of dozens of eggs disposed of should be placed in the columns so designated; all else should be entered in the Misc. column unless it is desired to separate some other class of items such as meat, breeding stock, day-old chicks, etc., when the middle column may be so marked and used.

No entries should be made for eggs used for hatching or for any other such operations which are neither poultry credits nor debits; merely the use of one form of finished product as a raw product for the production of another.

Show settlements of accounts by ✓ as for the debits.

Incubation Record; Page 4.—The column headed "identification" is intended for any mark or name by which the

hatch may be known, such as name of incubator, location of setting hen, etc.

The "per cent. infertile" is calculated by dividing 100 times the number of infertile eggs by the number of eggs set. Similarly the "per cent. hatched of total eggs" is calculated by dividing 100 times the number of chicks hatched by the number of eggs set.

The mark X means that no entry is to be made in that particular space.

Brooder Record; Page 5.—The column headed "identification" is to be used in the same way as that in the incubation record.

When the various hatches are kept separate, the mortality of each flock may be kept on sheets of paper fastened in the brooders, colony houses, or coops, and recorded monthly in this book until the pullets are placed in the laying house.

When cockerels are removed they are to be recorded in the "sold, eaten, or removed" column whether they are sold or simply placed in another part of the farm. If they are sold or eaten they are to be recorded in the "credits" (pages 10-13); if they are held for breeders or for sale as breeders, they will be recorded on the flock record sheet when counted each month (pages 3-4). No further mortality record is kept for the cockerels after their removal from the pullets except as may be noted in the monthly counts and inventories.

Material Inventory; Page 7.—This inventory should be taken at the beginning and end of the record period.

If real estate, portable buildings, etc. are used jointly by the poultry and other farm enterprises, the proportional part used by the poultry should be estimated, and included in the inventory.

Any increase or decrease in the inventory during the record period will appear as a profit or loss respectively, at the bottom of the sheet, so be sure that any difference between the two inventories is accounted for by a purchase or sale recorded with the debits or credits respectively, or by an actual increase or decrease in value due to other causes than change in general property values.

Any items not specifically printed in this inventory list may be written in the blank spaces.

The value placed upon all items should be that at which they could probably be sold on the farm. Ordinarily 5 to 20 per cent. depreciation in value per year should ordinarily be allowed on items to cover the cost of repairs, replacements, and the continual lowering of the selling value.

General Statement and Summary for the Period.—The statement and summary which will be made up will include such calculations as egg production; value of eggs; cost of feed, mortality by the month and for the whole period, in totals, percentages and averages; total gain or loss; and labor income.

Operator..... Period.....191.. to..... 191..

FLOCK RECORD

No. of hens to begin period..... Breed.....

PEN SHEET; Nov.-APRIL

Nov.	Days																															Totals	Count				
	1	2	3	4	5	6	7	8	9	10	11	12	13	14	15	16	17	18	19	20	21	22	23	24	25	26	27	28	29	30	31						
Hens died.....																																					
Hens disposed of.																																					
Hens added.....																																					
Hens died.....																																					
Hens disposed of.																																					
Hens added.....																																					
Hens died.....																																					
Hens disposed of.																																					
Hens added.....																																					
Hens died.....																																					
Hens disposed of.																																					
Hens added.....																																					
Hens died.....																																					
Hens disposed of.																																					
Hens added.....																																					
Hens died.....																																					
Hens disposed of.																																					
Hens added.....																																					
Hens died.....																																					
Hens disposed of.																																					
Hens added.....																																					
Hens died.....																																					
Hens disposed of.																																					
Hens added.....																																					

The fiscal year in egg production begins Nov. 1 each year and ends with Oct. 31 of the following year.

POULTRY DEBITS

Date	Description of items	Values					
			Feed			Misc.	
		(Lb)	\$	\$	\$		
	Carried forward						

POULTRY DEBITS

Date	Description of items	Values			
			Feed		Misc.
	Brought forward	(lbs.) \$	\$	\$	\$
	Brought forward				

POULTRY CREDITS

Date	Description of items	Values			
			Eggs		Misc.
		Doz. \$	\$	\$	\$
	Carried forward				

MATERIAL INVENTORY

Items	Number or amount	Price	Value	
			Beginning of period	End of period
Real estate used for poultry . . .		\$	\$	\$
Portable buildings				
Hens				
Pullets				
Males				
Young stock				
Ducks				
Geese				
Turkeys				
Other poultry				
Horses used for poultry				

MATERIAL INVENTORY (Continued)

Items	Number or amount	Price	Value	
			Beginning of period	End of period
Feed for poultry				
Feed for other stock				
Crops and prepared ground				
Manure and fertilizer				
Litter				
Incubators				
Brooders				
Wagons and harnesses				

MATERIAL INVENTORY (Continued)

Items	Number or amount	Price	Value		
			Beginning of period		End of period
Farm tools.....					
Small tools.....					
Shipping coops.....					
Egg cases.....					
Pails and baskets.....					
Other supplies.....					
Eggs.....					
Dressed poultry.....					
Feathers.....					
Total.....	X	X			
Gain during period (increased inventory).....	X	X	X		
Loss during period (decreased inventory).....	X	X			X

POULTRY RECORD
MONTHLY REPORT SHEET

Name of Operator.....
 Address.....
 Date 191. for month of 191.
 Totals for month:
 Hens died..... Hens disposed of..... Hens added.....
 Date counted 191. No. Hens..... Males.....
 Doz. Eggs produced.....
 Poultry Debits:
 Pounds feed debited Value \$..... All other debits \$.....
 Poultry Credits:
 Doz. Eggs Credited..... Value \$..... All other credits \$.....
 No. of eggs set during month.....
 No. of chicks hatched during month.....

POULTRY ACCOUNTANT WORK

FINANCIAL RECORD OF A LAYING FLOCK

Prepared by The American Association of Poultry Instructors and
 Investigators.

Name..... State..... County..... Post Office.....
 Record for the year ending..... 19... Breed.....

(The year should begin at the time when pullets are added to the laying flock.)

Record filled out by..... Date of report.....

INVENTORIES, PURCHASES, ADDITIONS, AND SALES

	Beginning of year ¹		Purchases and additions		Sold or eaten		Deaths ²	End of year ³	
	No.	Value	No.	Value	No.	Value		No.	Value
Hens hatched, 1917									
Hens hatched, 1916									
Hens hatched, 1915									
Hens hatched, 1914									
Males									
Total									

¹ Value pullets at the time they were added to the laying flock at the price they normally would have sold for on the farm.

² If the deaths are not recorded, give the shortage at the end of the year.

³ In valuing poultry at the end of the year, deduct the usual percentage for depreciation due to age from the value as given at the beginning of the year.

DEPRECIATION

Inventory at beginning of year	\$.....	
Purchases and additions	
Total		\$.....
Sold or eaten	\$.....	
Inventory at end of year	
Total		\$.....
Difference equals depreciation		\$.....

FEED

(Do not include that used for raising chickens)

	Pounds	Price	Total value
Home grown:			
Corn.....		\$	\$
Wheat.....			
Barley.....			
Beets.....			
Cabbage.....			
Skim milk.....			
Purchased:			
Corn.....			
Wheat.....			
Barley.....			
Mixed grains.....			
Bran.....			
Middlings.....			
Cornmeal.....			
Gluten.....			
Meat scrap.....			

FEED SUMMARY

	Pounds	Value
Grains.....		\$
Mash.....		
Skim milk.....	*	
Beets and other succulent feed.....	*	
Total.....		\$

* To reduce skim milk, beets, etc., to dry matter basis, comparable with other feeds so that the total may be added, divide the pounds by 10.

GRIT AND SHELL

Oyster shell.....	lb.	\$
Grit.....	lb.	\$
Total.....	lb.	\$

LITTER

Kind	Amount	Value
		\$
Total.....		\$

LABOR

	Human hours	Horse hours
Daily chores and care of flock.....		
Mixing feed.....		
Preparing eggs for market.....		
Hauling eggs and stock.....		
Cleaning houses.....		
Hauling litter.....		
Hauling feed.....		
Whitewashing houses.....		
Making and repairing fences.....		
Buying, selling, and collecting, for feed, poultry, eggs, and supplies.....		
Accounting, etc.....		
Other labor.....		
Total.....		
Value of labor per hour.....		
Total value.....	\$	\$

BUILDINGS

Value of buildings for the flock, including the proportionate share of buildings used for storage of feed, litter, supplies, equipment, etc. \$.....

Taxes on buildings \$.....
 Insurance on buildings
 Depreciation on buildings
 Interest on buildings

 Total

\$.....

LAND

Value of land used by the laying flock \$.....
 Charge taxes, interest, fences, seeds, and
 other costs of yards and ranges. \$.....

WATER

Charge the flock with its share of the in-
 terest and upkeep of the water supply. \$.....

EQUIPMENT

Coops, pails, feed hoppers, and other
 special poultry equipment, value \$.....
 Charge taxes, interest, repairs, insurance,
 and depreciation. \$.....
 Charge wagons, harness, trucks, and autos
 in proportion as they are used for the
 laying flock. \$.....
 Total equipment \$.....

INTEREST ON STOCK

Average inventory of stock from page 1, No.....
 Value \$..... Interest at % \$.....

INTEREST ON FEED AND SUPPLIES

MISCELLANEOUS COSTS

Interest at % on investment in feed and supplies. \$.....

	Quantity	Value
Egg cases.....		\$
Other market carriers.....		
Shipping tags.....		
Nails and wire for shipping cases.....		
Excelsior.....		
Freight.....		
Express.....		

	Quantity	Value
Commissions.....		
Affidavits.....		
Insurance on stock.....		
Leg bands.....		
Carbolineum, lime, sprays, etc.....		
Medicines.....		
Kerosene and other light.....		
Gasoline (hens' share for truck or auto).....		
Paid for hauling feed, supplies, eggs, etc.....		
Railroad fares.....		
Telegrams.....		
Telephones.....		
Association dues.....		
Trade papers.....		
Postage.....		
Stationery.....		
Advertising.....		
Other costs.....		
Total.....		\$

POULTRY CULTURE

EGGS

	Dozens	Price per dozen	Total value
Eggs sold (exclusive of hatching eggs):			
November ¹		\$	\$
December.....			
January.....			
February.....			
March.....			
April.....			
May.....			
June.....			
July.....			
August.....			
September.....			
October.....			
Total.....			\$
Eggs sold for hatching.....			
Eggs used for hatching day-old chicks for sale.....			
Eggs set or incubated for flock..			
Eggs consumed on farm.....			
Total eggs produced.....			

¹ If the year does not begin on November 1, rewrite the months so that the first month given is the beginning of your year.

MANURE

Manure recovered from laying flock for use on crop land

Tons.....Price per ton \$.....Value \$.....

MISCELLANEOUS RETURNS

Feed bags sold.....\$.....

Feathers.....\$.....

SUMMARY OF COSTS AND RETURNS

	From page	Quantity		Value	
		Total	Per bird	Total	Per bird ¹
Costs:					
Depreciation.....	1	%		\$	\$
Total feed.....	2	lb.	lb.		
Grit and shell.....	2	"	"		
Litter.....	2	"	"		
Labor:					
Human.....	3	hr.	hr.		
Horse.....	3	"	"		
Buildings.....	3	X	X		
Land.....	3	X	X		
Water.....	3	X	X		
Equipment.....	3	X	X		
Interest on stock.....	4	X	X		
Interest on feed and supplies.....	4	X	X		
Miscellaneous.....	4	X	X		
Total costs.....	X	X	X	\$	\$
Returns:					
Total eggs produced.....	5	doz.			
Manure.....	6				
Miscellaneous.....	6				
Total returns.....	X	X	X		
Gain or loss.....	X	X	X		

Cost of eggs equals total costs less manure and miscellaneous returns. Total cost \$.....Cost per dozen.....¢. Cost per bird¹ \$.....

¹ "Bird" includes males and females."

POULTRY ACCOUNTANT WORK

FINANCIAL RECORD OF CHICKENS RAISED

Prepared by American Poultry Association, American Association of Poultry Instructors and Investigators.

Name..... State..... County..... Post Office.....

Record for the year 19..... Breed.....

Give purpose for which reared (broilers, fryers, roasters, capons, etc.)

Age at which sold.....

Record filled out by..... Date of report.....

FEED

(Include only that used for raising chickens)

	Pounds	Price	Total value
Home grown:			
Corn.....		\$	\$
Wheat.....			
Barley.....			
Beets.....			
Cabbage.....			
Skim milk.....			
Purchased:			
Corn.....			
Wheat.....			
Barley.....			
Mixed grains.....			
Bran.....			
Middlings.....			
Cornmeal.....			
Gluten.....			
Meat scrap.....			

FEED SUMMARY

	Pounds	Value
Grains.....		\$
Mash.....		
Skim milk.....	*	
Beets and other succulent feed.....	*	
Total.....		\$

* To reduce skim milk, beets, etc., to dry matter basis, comparable with other feeds so that the total may be added, divide the pounds by 10.

GRIT AND SHELL

Oyster shell.....	lb.	\$
Grit.....	lb.	\$
Total.....	X	\$

LITTER

Kind	Amount	Value
		\$
Total.....		\$

LABOR
(Raising chickens)

	Human hours	Horse hours
Incubation and care of incubators		
Daily chores		
Mixing feed		
Cleaning houses		
Hauling bedding		
Hauling feed		
Whitewashing houses		
Making and repairing fences		
Buying, selling, and collecting, for feed, poultry, and supplies		
Accounting, etc.		
Other labor		
Total		
Value of labor per hour		
Total value	\$	\$

BUILDINGS

Value of colony houses, incubator houses,
and including the proportionate share of
buildings used for storage of feed, bed-
ding, supplies, equipment, etc. \$.....

Taxes on buildings \$.....

Insurance on buildings

Depreciation on buildings

Interest on buildings

Total \$.....

LAND

Value of land used by the chickens \$.
 Charge taxes, interest, fences, seeds, and
 other costs of yards and ranges. \$

WATER

Charge the chickens with their share of
 the interest and upkeep of the water supply. \$

EQUIPMENT

Incubators, brooders, coops, pails, feed
 hoppers, and other special poultry equip-
 ment value \$.
 Charge taxes, interest, repairs, insurance,
 and depreciation. \$
 Charge wagons, harness, trucks, and autos
 in proportion as they are used for the
 chickens \$
 Total equipment \$

EGGS INCUBATED

Number eggs hatched. Value \$.
 Number chickens hatched.

INTEREST ON FEED AND SUPPLIES

Interest at % on investment in feed and supplies \$.

MISCELLANEOUS COSTS

	Quantity	Value
Market carriers.		\$
Shipping tags.		
Freight.		
Express.		
Commissions.		
Affidavits.		
Leg bands.		
Carbolineum, lime, sprays, etc.		

MISCELLANEOUS COSTS (Continued)

	Quantity	Value
Medicines.....		
Fuel for incubators (give kind).....		
Fuel for brooders (give kind).....		
Kerosene and other light.....		
Gasoline (chickens' share for truck or auto, engine, etc.).....		
Paid for hauling feed, supplies, etc.....		
Railroad fares.....		
Telegrams.....		
Telephones.....		
Postage.....		\$
Stationery.....		\$
Advertising.....		
Other costs.....		
Total.....		\$

MANURE

Manure recovered from brooder houses, tons..... Value \$.....

MISCELLANEOUS RETURNS

Feed bags sold \$.....

CHICKENS RAISED

	No.	Weight	Value
Sold for human consumption or eaten on the farm.....			\$
Sold for breeding or laying.....			
Pullets kept for breeding or laying.....			
Cockerels kept for breeding.....			
Total.....			\$

SUMMARY OF COSTS AND RETURNS

	Quantity	Value
Costs:		
Total feed.....		\$
Grit and shell.....		
Litter.....		
Labor:		
Human.....		
Horse.....		
Buildings.....		
Land.....		
Water.....		
Equipment.....		
Eggs incubated.....		
Interest on feed and supplies.....		
Miscellaneous.....		
Total costs.....		
Returns:		
Chickens raised.....		
Manure.....		
Miscellaneous.....		
Total returns.....		
Gain or loss.....		\$

MEAT COST

Total pounds of meat produced..... Total cost equals the
total cost less returns for manure and miscellaneous returns..... \$...
Cost per pound \$.

PULLET COST

No. pullets raised for breeding or laying..... Net cost per
pullets equals total cost less all returns except for pullets kept or
sold as layers \$. Cost per pullet \$.

INDEX

A

ABDOMEN, 21
Absorption, 261, 263
Acari, 314
African Geese, 78
Age identification, 112
Air, 163
 amount required, 168
 carbon dioxid, 166
 composition, 163
 impurities, 166
 oxygen, 166 -
 respired, 165
 sacs, 165
 shafts, 172
 supply, 170
 watery vapor, 166
Alarm, electric, 436
Albino, 85
Albuminoid, 21, 252
Aleurone layer, 282
Alfalfa, 21
Alimentary tract, 21
American class, 31, 38, 45
 Buckeyes, 31, 54
 Dominiques, 31, 54
 general characteristics, 38
 Javas, 31, 54
 Plymouth Rocks, 31, 45
 Rhode Island Reds, 31, 52
 Wyandottes, 31, 48
Amount feed consumed, 330
Amylopsin, 256
Anabolism, 260
Analyses of feed stuffs, 297, 303
Anatomy of chicken, 20
Anconas, 32, 38, 61
 Rose Comb, 61
 Single Comb, 61
Animal food, 290
 buttermilk, 290
 condensed milk, 290
 dried blood, 291
 bone, 292
 buttermilk, 291
 fish scrap, 292
 meat scrap, 291

Animal food, milk albumin, 291
 protein, 278, 290
Antiseptic, 21
Artificial lights in egg production,
 329
 selection, 21
Ascaridæ, 244
Ascaris inflexa, 244
Ash, 21, 252, 268
Asiatics, 31, 37, 55
 Brahma, 31, 37, 55
 Cochins, 31, 37, 57
 Langshans, 21, 37, 57
Assimilate, 21
Avenine, 285
Avian diphtheria, 234
Aylesbury Duck, 76
 White, 34, 76

B

BABY chick, care in transit, 457
 industry, 457
Bacillus avisepticus, 228
 pullorum, 230
 tuberculosis, 232
Balanced ration, 21
Banding, 158
Barley, 283
Barred Plymouth Rock, 31, 38, 46,
 91
Barring, 21
Baths, pigeons, 158
Beard, 21
Bearded Golden Polish, 32, 40
 Silver Polish, 32, 40
 White Polish, 32, 40
Beet pulp, 292
Beri Beri, 274
Bile, 258
Bilirubin, 258
Biliverdin, 258
Birchen Bantam, 33
 Game, 33
Birds for breeding, 87
 for exhibition, 511
Black Bantam, 33

- Black Bantam, Breasted Red
 Game, 33
 Bantam, 33
 Malay, 33
 Turkey, 74
 Blackhead, 225
 Bleeding, 272, 376
 Blood meal, 291
 Blue Andalusian, 32, 61
 corn, 280
 Swedish Duck, 34, 78
 Body louse, 237
 Boiling oil preservation of eggs, 473
 Bone, dry, 292
 green, 292
 Boning fowls, 389
 Booted Bantam, 71
 Bourdon Turkey, 74, 76
 Boxes for baby chicks, 457
 for dressed poultry, 382
 Boy's and Girl's poultry house, 182
 Brahma Bantam, 33, 73
 Dark, 31, 55, 57
 Light, 31, 55, 57
 selection for breeding, 89
 Bran, 283
 Branch, 20
 Bread crumbs, 283
 Breeding, 130
 chart, 131
 ducks, 149
 geese, 150
 guineas, 150
 inbreeding, 130
 line, 130
 out crossing, 130
 pedigree, 134
 pen, 21
 pigeons, 151
 turkeys, 148
 Breeds, 33
 Campine, 68
 classification of, 37
 Cochins, 31, 57
 Crevecoeurs, 32, 68
 Dorkings, 38
 ducks, 34, 76
 East India Ducks, 34, 76, 77
 Favorelle, 68
 feathered shanks, 39
 games, 33, 69
 bantams, 33, 69
 geese, 34, 78
 Hamburgs, 32, 67
 Breeds, history, 45
 Japanese Bantam, 33, 71
 Java, 31, 54
 La Fleche, 32, 68
 Langshan, 31, 57
 Leghorn, 32, 58
 Minorca, 32, 60
 of poultry, 31
 Orpington, 32, 62
 pigeons, 34
 Plymouth Rock, 38
 Rose Comb Bantam, 33, 71
 shanks not feathered, 39
 Spanish, 32, 60
 Sumatra, 33, 70
 turkeys, 33, 74
 Wyandottes, 31, 48
 Brewers' grain, 284
 Broilers, 21, 363
 large, 363
 medium, 364
 squab, 27, 363
 Bronze Turkey, 74
 Brood, 21, 408, 439
 Brooder, colony house, 438
 fireless, 445
 heated, 440
 home-made, 444
 indoor, 438
 mammoth, 426
 on large scale, 450
 outdoor, 438
 Brooding, 438
 artificial, 438
 cold, 445
 natural, 438
 Broody coop, 416
 hens, 147
 times, 147
 Broom corn, 286
 Brown Chinese Geese, 34, 79
 Leghorn, 32, 58
 Red Game, 33, 69
 Buckeyes, 31, 54
 Buckwheat, 285
 bran, 285
 flour, 286
 hulls, 286
 middlings, 286
 shorts, 286
 Buff Cochin, 31, 57
 Bantams, 33, 73
 Laced Polish, 33, 67
 Bantams, 33, 73

- Buff Orpington, 32, 62
 Duck, 34, 78
 Plymouth Rock, 31, 48
 Turkey, 33, 74
 Wyandotte, 31, 50
 Buttermilk, 290
 By-products, 282
- C
- CALL Duck, 76
 Calorie, 21
 Campines, 33, 68
 Golden, 68
 Silver, 68
 Canadian Goose, 34, 80
 Candling eggs, 409, 481, 493
 Cane sugar, 251
 Capacity, 21
 Cape, 21
 Capon, 21, 367, 504
 picking, 376
 Caponizing, 504
 Car lot shipment of poultry and
 eggs, 470
 Carbohydrates, 21, 251, 252, 266
 Carbon dioxid of air, 166, 251
 Cards, record, 217
 Care of buildings and equipment,
 210
 of nests, 463
 of sick birds, 218
 Carriage, 21
 Caruncles, 22
 Carunculated, 22
 Casein, 21
 Castration of male bird, 504
 Catarrh of crop, 223
 Cayuga Duck, 76
 Cecum, 255
 worm, 245
 Cellulose, 250, 252
 Changes due to laying, 108
 abdomen, 109
 beak, 108
 body, 109
 comb, 110
 ear lobe, 108
 eye ring, 108
 molting, 110
 secondary sex characters, 110
 shanks, 109
 skin, 108
 vent, 108, 109
 wattles, 110
- Characters, 128
 dominant, 128
 recessive, 128
 Chick feeding, 331
 wheat, 282
 Chicken, 22
 cholera, 228
 mite, 239
 pox, 233
 stewing, 29
 Chicks, 22
 commercial production, 256,
 405
 mortality, 456
 protection from hawks and rats,
 416
 providing shade, 442, 443
 Chigger, 239
 Chinese Geese, 78
 Brown, 79
 White, 79
 Cholesterine, 258
 Chyle, 262
 Class, 20, 31
 American, 31
 Asiatic, 31, 137
 general characteristics, 37
 Continental, 33, 68
 Duck, 33, 76
 English, 32, 61, 62, 65, 66, 67,
 68
 French, 32, 67
 Games and Bantams, 61
 Geese, 33, 78
 Guineas, 33
 Hamburg, 32, 67
 Mediterranean, 58
 general characteristics, 38
 Miscellaneous, 33, 74
 Oriental, 33
 Ornamental bantams, 33, 77
 Pigeons, 33
 Polish, 32, 66
 Turkey, 32,
 Classes of winter layers, 98
 Classification of breeds, 37
 of fowls, 20
 Claviceps purpura, 312
 Cleaning dropping boards, 211
 Cloacitis, 224
 Club Boy's and Girl's poultry
 houses, 182
 Coccidiosis, 23
 Cochin Bantams, 73

- Cochin Bantams, Black, 73
 Buff, 73
 Partridge, 73
 White, 73
 Black, 31, 57
 Buff, 31, 57
 Partridge, 31, 57
 selection for breeding, 88
 White, 31, 57
 Cock, 22
 Cockerel, 22
 Cold storage eggs, 462, 463
 Colitis, 224
 Collecting eggs, 465
 Colony house brooder, 439
 Color problem, 84
 Colored Dorking, 32, 61
 Egyptian Geese, 34, 80
 Muscovy Ducks, 34, 77
 Rouen Ducks, 34, 76
 Columbian Plymouth Rock, 45
 Wyandotte, 45
 Comb, 22
 pea, 28
 rose, 28
 single, 28
 strawberry, 28
 v-shaped, 28
 Combination sitting and brooding
 coop, 412, 413
 protection from rats, 524
 Community egg circle, 482
 Composition of air, 164
 Concentrated feeds, 280
 Concentrates, 22
 Concrete floors, 180, 192
 construction, 192
 Condensed buttermilk, 290
 Condition, 22
 Constitutional vigor, 138
 Construction of poultry houses,
 173
 clubs, 185
 drop or muslin curtains, 179
 floors, 173, 176, 180
 list of materials, 182, 183,
 197
 plans, 177, 181, 184
 portable, 199, 201
 roof, 173
 sides and ends, 173
 unit system, 180
 Consumption, 232
 Contagious, 214
 Contagious diseases, 225
 blackhead, 225
 chicken pox, 233
 fowl cholera, 228
 roup, 234
 tuberculosis, 232
 white diarrhea, 230
 Continental class, 33, 68
 Campines, 33, 68
 Cooling dressed pigeons, 159
 poultry, 373
 Coöperative marketing, 482
 Coops for shipping live poultry,
 362
 sitting, 412
 Corn, 22, 280
 and cob meal, 281
 bran, 281
 meal, 282
 smut, 312
 Cornell outline for student prac-
 tice, 80
 study outline, 37
 Cornish, 32, 65
 Dark, 32, 65
 White, 32, 66
 Laced, 32, 65
 Cost of commercial picking, 371
 Cottage cheese, 290
 Cottonseed, 286
 hulls, 286
 meal, 286
 Cow pea, 290
 Cracked corn, 281
 Cracker crumbs, 283
 Crest, 22
 Crested Ducks, 34, 77
 White, 77
 Crevecoeurs, 32, 68
 Black, 68
 Crop, 22
 bound, 223
 Cross breeding, effects, 142
 Crude fiber, 22
 Cushion, 22
- D
- DAMP grain, 312
 Dark Brahma, 31, 56
 Bantam, 33, 73
 Cornish, 32, 65
 Dent corn, 281
 Development, parts of chick, 346

- Diagram of ventilation, 168, 169
 Diastase, 22
 Diffusion of air, 170
 Digestibility, 253, 276
 Digestible matter, 22, 276
 nutrients, 276, 298
 Digestion, 254
 physiology, 253
 Digestive juices, 254
 tract, 22, 254
 Dihybridism, 121, 122
 Dirt floor, 189
 Dirty eggs, 461
 Discontinuous variation, 125
 Diseased feeds, 308
 Diseases, contagious, 225
 crop, 223
 gangrene, 223
 impaction, 223
 noncontagious, 222
 of feeds, 311
 Disinfect, 215
 Disinfecting, 211, 215
 Disinfection, 22
 Disinfest, 22
 Disqualification, 22
 Distribution of egg production, 98
 Dominique, 31, 54
 Rose Comb, 31, 54
 Doors, methods of hanging, 172
 Dorking, 32, 61
 Colored, 32, 61
 Silver Gray, 32, 61
 White, 32, 62
 Double yardage system, 187
 Down, 22
 Drake, 22
 Drawing fowls, 387
 Dressed poultry classification, 368
 score card, 391
 Dressing broilers, 363
 boxes, 382
 capons, 376
 cost, 371
 ducks, 376
 fowls, 372
 geese, 374
 killing, 368
 loss in weight, 390
 per cent. dressed weight, 390
 pigeons, 386
 poultry, 368
 refrigerating, 378
 room, 368
- Dressing broilers, shipment, 470
 sticking knife, 369
 turkeys, 376
 Dried brewers' grain, 284
 buttermilk, 291
 Drop curtain, 179
 Dropping boards, cleaning, 211
 construction, 174, 201
 box, 522
 scrape, 522
 Dry air, 166
 eggs, 373
 fish scrap, 292
 litter feeding chicks, 336
 matter, 22
 meat scrap, 292
 packing poultry, 377
 picking, 372
 Dubbed, 23
 Dubbing, 23
 Duck, age for breeding, 149
 Aylesbury, 34, 76
 breeding, 149
 Call, 34, 77
 Cayuga, 34, 77
 class, 34, 76
 distinguishing sex, 149
 East India, 34, 77
 feeding, 337
 footed, 23
 housing, 344
 Indian Runner, 33, 77
 Muscovy, 34, 77
 number ducks to each drake, 149
 Orpington, 34, 77
 Pekin, 34, 77
 Penciled Runner, 34, 77
 Rouen, 34, 77
 Swedish, 34, 77
 Ducklings, 23
 Duodenal fold, 255
 Duodenum, 255
 Dusting a hen, 238
- E
- EAR-LOBE, 23, 40
 red, 39
 white, 40
 Early maturing, 144
 East India Duck, 34, 77
 Egg, absorb odors, 465
 air space, 493
 blind checks, 489
 blood rings, 491

- Egg, boiled, 495**
 broken, 490
 by parcel post, 468
 candling, 409, 489, 493, 499
 chart, 497
 for market, 463
 white, 493
 yolk, 493
 car lot shipment, 470, 472
 care, 407
 of market, 468
 cases, 480
 cushions, 480
 fillers, 480
 flats, 480
 wood used, 481
 causes of changes, 491
 checks, 489
 chick production, 405
 circle, 482
 classification of dirties, 462
 collecting on cream routes, 481
 color, 498
 coöperative marketing, 481
 delivered same day laid, 474
 dirty, 401
 eating hens, 219
 effect of feed on color of yolk,
 466
 on quality, 463
 expectancy, 104
 export, 480
 factors affecting color, 492
 quality, 492
 for sitting, 400, 401
 foreign matter, 490
 fresh extras, 489
 firsts, 489
 grading, 489
 heated, 489
 heavy floats, 495
 held in cold storage, 463
 how to load cars, 470
 to sit a hen, 408
 transported, 478
 incubation, 405
 infertile incubated, 495
 judging, 498
 laboratory chart, 494
 leakers, 490
 light float, 495
 limed, 495
 losses, 498
 causes, 459
- Egg, males not needed in pro-**
duction of market eggs, 468
 marketing, 474, 477
 cost, 477
 meat spot, 491, 495
 mixed rot, 490, 500
 most economic size package, 466
 musty, 462
 on cream routes, 481
 packing for shipping, 404, 466
 per cent. cost of feed, 456
 hatching expectancy, 404
 preserving, 472
 drying, 473
 freezing, 473
 oil, 473
 refrigeration, 476
 water glass, 472
 production, 141
 distribution, 98
 factors which hinder, 141
 for market, 465
 hatching expectancy, 404
 judging, 107
 pullet, 462
 rot, 491
 seconds, 489
 selection for sitting, 400
 shrunken, 490
 small, 490
 spots, 490
 rot, 491
 storage, 476
 cost, 478
 strength of shell, 404
 time for hatching, 405
 turning, 421
 watery, 490
 weights affected by season, 492
 when to hatch for winter layers,
 467
 white rot, 491
Egyptian Geese, 78, 80
Electric alarm, 436
Electroborators, 425
Emden Geese, 78
 White, 78
Emulsion, 23
English class, 61, 64
 Dorking, 32, 61
 Orpington, 32, 62
 Red Caps, 32, 64
 Sussex, 32, 64
Ensilage, 23, 292

Enterohepatitis, 225
 Enterokinase, 261
 Epiornithics, 210
 Erepsin, 257
 Ergot, 283
 Esophagus, 253
 Established points, 23
 Ether extract, 23
 Evening scratch feed, 321, 323
 Excrement, 23
 Exercise for hens, 176
 Exerciser, home-made, 349
 Exhibition birds, 511
 External anatomy of fowl, 20
 parasites, 236
 Eye-ring, 23

F

FACE, 23
 white, 28
 Fancy poultry, 23
 Farm flock, 208
 poultry problems, 138
 Fat, 277
 tallow fattening, 359, 361, 367
 reservoirs, 267
 Fattening birds, 330, 334, 353, 359,
 360
 establishments, 360
 funnel cramming, 361
 geese, 339
 hand cramming, 360
 Favorelle, Golden, 32, 68
 Fawn Indian Runner, 77
 Feather, 23
 care of, 392
 handling, 394
 market grades, 394
 pulling, 220
 shipping, 394
 shrinkage, 394
 yield, 396
 Feed, amount consumed, 330
 animal protein, 290
 barley, 283
 beet pulp, 292
 bone, 292
 bran, 282
 broom corn, 286
 buckwheat, 283
 buttermilk, 290
 corn, 281
 cracked, 281

Feed, cornmeal, 282
 cottonseed meal, 286
 cow peas, 290
 ensilage, 292
 exerciser, 348
 fish scrap, 292
 flax-seed, 288
 for pigeons, 151
 gluten feed, 281
 grazing crop, 294
 hopper, 322
 kaffir corn, 286
 middlings, 282
 milk albumin, 291
 millet, 286
 oats, 284
 palatability of, 330
 peanut meal, 289
 problems, 250
 rice, 285
 shorts, 282
 sorghum, 286
 soybean meal, 289
 spoilt, 308
 succulent feed, 292
 table of analyses, 299
 troughs, 215
 velvet bean meal, 289
 weights and measures, 307
 wheat, 282
 Feeding baby chicks, 331
 chicks, 331
 ducks, 337
 geese, 337
 guineas, 347
 laying hens, 317
 methods, 315
 pigeons, 156, 347
 poult, 336
 turkeys, 336
 Feet space per bird in yard, 188
 Felch breeding chart, 131
 Fencing material, 203
 cement, 204
 posts, 203
 rectangular, 204
 six-sided wire mesh, 204
 steel, 204
 wire, 204
 wood posts, 204
 Fertility, 146
 after mating, 146
 removal of males, 146
 hens' eggs, 143

Fertility, percentage, 146
 pullet eggs, 147
 Fertilization, chance, 127
 Finishing birds, 353
 Fireless brooder, 445
 Fish scrap, 292
 Fixing characters, 96, 116
 Fleshing, 353
 Flight coverts, 23
 Flights, 23
 Fluff, 23
 Foot tons, 23
 Footings, 23
 Forced mating, 158
 Fowl cholera, 228
 classification, 20
 peacomb, 37
 single comb, 37
 white skin, 37, 379
 yellow skin, 37, 379
 French class, 32, 67
 Crevecœurs, 32, 68
 Houdans, 32, 67
 La Fleche, 32, 68
 Fresh blood, 23
 Frizzles, 23
 Frosting, 23
 Frozen poultry, 378
 Fryer, 23, 366
 Fungus, 312
 Furnished, 23

G

GALL, 258
 acids, 258
 pigment, 258
 Gall-bladder, 258
 Gallus Bankiva, 84
 Game Bantam, 69
 Birchen, 33, 69
 Black, 33, 69
 Breasted Red, 33, 69
 Brown, Red, 33, 69
 Red Pile, 33, 69
 Silver Duckwing, 33, 69
 White, 33, 69
 Games, 69
 Black, 69
 White, 69
 Gametic segregation, 125
 Gangrene, 223
 Gape worm, 246
 Gapes, 247

Gastric juice, 254
 Geese, 34, 78
 African, 34, 78, 79
 age for breeding, 150
 bleeding, 374
 Canadian, 34, 80
 care of sitting goose, 150
 Chinese, 34, 79
 Egyptian, 34, 80
 Embden, 34, 80
 feeding, 337
 number geese to one gander, 150
 selection for breeding, 150
 Toulouse, 34, 79
 when to mate, 150
 wild, 34, 80
 Germicide, 23
 Gills, 23
 Gizzard, 254
 worm, 246
 Glossary of terms, 21
 Glucose, 23
 Gluten feed, 281
 Glycocholate of soda, 258
 Glycogen, 259, 266
 Gonoides stylifer, 237
 Grading eggs, 489
 Grain, 280
 storage bin, 516
 Gram, 23
 Gravel floor, 176
 Gray African Goose, 79
 Call Duck, 34, 77
 Indian Runner Duck, 77
 Toulouse Goose, 79
 Grazing crops, 294
 Green bone, 24
 goose, 24
 Ground dry bone, 292
 Growing show birds, 514
 Guinea Fowls, 150
 breeds, 150
 hatching, 151
 how to distinguish sex, 150
 how to manage, 150
 number females to be mated to
 one male, 150
 Gullet, 24

H

HACKLE, 24
 Hamburg class, 32, 67
 Black, 32, 67

- Hamburg class, Golden Penciled, 32, 67
 Spangled, 32, 67
 selection for breeding, 94
 Silver Penciled, 32, 67
 Handling fowls, 515
 Hangers, 24
 Hanging doors, 172
 Hard feathered, 24
 Hatchability 24, 140, 143
 percentage, 146
 artificial incubation, 146
 natural incubation, 146
 Hatching eggs, 400
 expectancy, 455
 Heavy breeds, 24
 Hen, 24
 feathered, 24
 History of breeds, 45
 Hock, 24
 Home-made brooder, 444
 Hopper for mash, 292
 Hormone, 272
 Hot mash, 292
 Houdans, 32, 67
 Mottled, 32, 67
 selection for mating, 94
 White, 32, 67
 House for ducks, 344
 Housing pigeons, 154
 fixtures for, 154
 How to dust a hen, 238
 to sit a hen, 408
 Hydrocarbon, 252, 266, 267
 Hygiene, 161
- I
- ICING dressed poultry, 377, 470
 Illumination in egg production, 329
 Impaction of crop, 223
 Impurities of air, 165
 Incomplete bleeding, 376
 Incubation, 405
 eggs, 422
 duck, 423, 424
 geese, 424
 guinea, 423
 hen, 422
 pigeon, 423
 turkey, 423
 Incubator, 417
 carbon dioxid, 434
 care, 417
 chicks dead in shell, 423
- Incubator, constant temperature
 essential, 432
 construction, 418
 crippled chicks, 423
 electric alarm, 436
 humidity, 433
 leveling, 422
 mammoth, 426
 overheating, 437
 poor hatches, 422
 position of thermometer, 433
 proper temperature, 433
 removing chicks, 422
 room, 422
 small, 417
 standardizing, 435
 Indian corn, 281
 Runner Duck, 76
 Inorganic matter, 252, 268
 Insect powder, 239
 Inspiration, 165
 Internal parasites, 243
 Intestinal juice, 261
 enterokinase, 261
 erepsin, 261
 invertinase, 261
 lactase, 261
 maltase, 261
 secretin, 261
 Introductory, 17
- J
- JAPANESE Bantams, 33, 74
 Black Tailed, 33, 74
 Gray, 33, 74
 White, 33, 74
 Java, 31, 54
 Black, 31, 54
 Mottled, 31, 54
 Jaw, 24
 Joint, knee, 24
 Judging hens for egg production,
 107, 110
 utility, 113
- K
- KAFFIR corn, 286
 Katabolism, 260
 Kidneys, 263
 Killing ducks, 374
 fowls, 368
 cooling, 373
 picking, 372

Killing geese, 374
 pigeons, 159
 turkeys, 374
 Kilogram, 24
 Knee-joint, 24
 Kupfer cells, 260

L

LACED, 24
 Lactal, 24
 La Fleche, 32, 67
 Lancashire method of trussing, 387
 Langshan, 31, 57
 Black, 31, 57
 White, 31, 57
 Large broilers, 366
 Lateral sternal process, 24
 Lay bones, 24
 Layers, temperament, 110
 Laying breeders, 317
 hen, 317
 time of, 105
 Leaf comb, 24
 Lecithin, 258
 Leg, 24
 bands, 145
 feathers, 24
 Leghorns, 32, 58
 Black, 32, 58
 Brown, 32, 58
 Rose Comb, 32, 58
 Single Comb, 32, 58
 Buff, 32, 58
 Rose Comb, 32, 58
 Single Comb, 32, 58
 selection for breeding, 94
 Silver, 32, 58
 White, 32, 58
 Rose Comb, 32, 58
 Single Comb, 32, 58
 Legumes, 24
 Lice, 236
 Light Brahma, 31, 55
 Bantams, 73
 Lights in egg production, 329
 Limber neck, 224
 Line breeding, 130
 Linseed, 288
 cake, 288
 meal, new process, 288
 old process, 288
 nut cake, 288

Lipase, 256
 Liperus baculus, 237
 Live poultry shipments, 362
 Liver, 255, 257
 function, 260, 261
 Livability of chickens, 140, 143
 Longevity, 143
 Lopped comb, 24
 Loss of fat due to laying, 108
 of pigment, 108
 Louse powder, 239
 Lungs, 165
 Lymph, 24, 262
 Lymphatic system, 23, 262

M

MAINTENANCE ration, 25
 Malay, 70
 Black Breasted Red, 70
 Malt, 283
 sprouts, 284
 Mammoth brooder, 450
 incubator, 426
 Mange, 241
 Mangles, 25
 Manure, poultry, 397
 amount voided, 397
 composition, 397
 preservation, 397
 value, 397
 Market grades of feathers, 392,
 395
 Marketing eggs, 473
 feathers, 394
 Marking, 157
 Mash, 24
 dry, 319, 321
 hopper, 516
 hot, 292
 Masticate, 25
 Mating, 24
 forced, 158
 problems, 82
 number to each male, 146
 when to save eggs after mating,
 146
 Maturing early, 82, 144
 pigeons, 157
 Mealy, 25
 Meat meal, 291
 scrap, 291
 type bird, 77, 113

- Mediterranean class, 58
 Anconas, 32, 61
 Blue Andalusians, 32, 61
 Leghorns, 32, 58
 Minorcas, 32, 60
 Spanish, 32, 60
 Medium broiler, 366
 Mendelism, 116
 Mendel's law, 116
 Menopon biseriatum, 236
 pallidum, 236
 Metabolism, 25, 260, 265
 anabolism, 260, 265
 katabolism, 260, 265
 Meter, 25
 Methods of feeding, 315
 of ventilation, 168
 Middlings, 282
 Milk albumin, 291
 Millet seed, 286
 Mineral matter, 25, 252
 aid to construction of tissues,
 270
 to function, 271
 how eliminated, 264
 kinds, 268
 requirements, 268
 used in body, 268
 Minorcas, 32, 60
 Black, 32, 60
 Rose Comb, 32, 60
 Single Comb, 32, 60
 White, 32, 60
 Rose Comb, 32, 60
 Single Comb, 32, 60
 Miscellaneous class, 74
 Frizzles, 74
 Silkies, 74
 Sultans, 74
 Mites, 239
 Mold, 312
 Molting, 221
 Monhybridism, 121
 Morning scratch feed, 321
 Mossy, 25
 Mottled, 25
 Houdans, 32, 67
 Javas, 32, 67
 Muffs, 25, 28
 Muscovy Duck, 34, 77
 Colored, 34, 77
 Muslin curtains, 179
 Musty eggs, 462
- N
- NARRAGANSETT Turkey, 74
 Natural selection, 25
 Nesting material, 57, 212
 hens, 212
 pigeons, 57
 Nests, 520
 construction, 520
 size necessary, 520
 Nitrogen-free-extract, 25, 252
 Nitrogenous substance, 25, 257
 Nits, 237
 Nonbearded Polish, 32, 67
 Bantams, 73
 Silver, 32, 67
 White, 32, 67
 Non-contagious diseases, 222
 catarrh, 223
 cloacitis, 224
 colitis, 224
 gangrene, 223
 impaction, 223
 limberneck, 224
 obstruction of beak, 222
 pip, 222
 sore mouth, 222
 Nursery tray, 418
 Nut cake, 288
 Nutrients, 25, 264
 digestible, 276
 required, 272
 Nutrition, 253, 264, 272
 Nutritive ratio, 25, 276, 277
- O
- OATMEAL, 284
 Oats, 284
 dust, 284
 hulls, 284
 shorts, 284
 smut, 284
 Obstruction of beak, 222
 Oil cake, 288
 meal, 25, 289
 Open front house, 200
 Organic matter, 25, 252
 Organization of egg circle, 483
 Organs of respiration, 165
 Oriental class, 70
 Booted, 70
 Malays, 70
 Bantams, 71

Oriental class, Sumatras, 70
 Ornamental Bantams, 71
 Booted, 71
 Brahma, 73
 Cochin, 73
 Japanese, 74
 Polish, 73
 Rose Comb, 71
 Sebright, 71
 Orpingtons, 62
 Black, 62
 Buff, 62
 Duck, 76
 White, 62
 Outcrossing, 130
 Out-door brooder, 438
 Outline for college course, 19
 Ovary, 107
 Oviduct, 107
 Oxygen of air, 165, 166

P

PACKING eggs for shipment, 481
 water fowl for shipment, 375
 Palatability of feeds, 330
 Pancreas, 254
 Pancreatic fluid, 254
 Parasites, external, 236
 chigger, 238,
 lice, 236
 scaly leg mite, 241
 internal, 243
 gape worm, 246
 gizzard worm, 246
 round worm, 241
 Parasiticide, 25
 Parasitism, 25
 Parti-colored, 25
 Partridge, Cochin, 31, 39, 57
 Bantam, 73.
 Plymouth Rock, 45
 Wyandotte, 31, 51
 Pasture, 295
 Pea comb, 25
 Peanut meal, 289
 Pedigree breeding, 134
 Pekin Duck, 77
 Pelvic arch, 25
 Pen, 25
 Penciled Runner Duck, 76
 Penciling, 25
 Peppered, 25
 Pepsin, 25, 254
 Persistency, 105

Pests, 220
 dogs, 220
 mink, 220
 opossum, 220
 pole cat, 220
 rats, 220
 Phagocytes, 260
 Physical changes of body due to
 laying, 106
 Physiology of digestion, 253
 Piano box house, 185
 Picking fowls, 372
 cooling, 373
 geese, 361, 375
 packing, 380
 per cent., dressed, 380
 pigeons, 386
 scald, 376
 shaping, 375
 turkeys, 376
 Pigeons, 35
 age affecting production, 153
 for marketing, 159
 Archangle, 35
 Barbes, 35
 breeding, 151
 Carneaux, 35
 cooling dressed squabs, 159
 Dragoons, 35
 English Carriers, 34
 Pouters, 34
 Fantail, 35
 feed, 151
 Florentine, 35
 Frillback, 35
 Helmets, 35
 housing, 153
 fixtures, 154
 nests, 154
 Hungarian Hens, 35
 Ice, 35
 Jacobins, 35
 killing squabs, 159
 live birds, how shipped, 160
 Magpies, 35
 Maltese, 35
 market, 159
 marketing, 157
 mating, 157
 Modena, 35
 Mondaines, 35
 Montahans, 35
 Moorheads, 35
 nesting material, 157

- Pigeons, Nuns, 35
 Oriental Frills, 35
 Owls, 35
 packing dressed squabs, 159
 pairs per pen, 157
 period of incubation, 159
 Polish Lynx, 35
 Porcellan, 35
 Pouters, 35
 prices of breeders, 159
 production per pair, 153
 Racing Homers, 151
 breeding, 151
 feed, 151
 lofts, 151
 Runt, 34
 Scanderoons, 35
 selection breeders, 157
 shipping birds, 159
 Squab Homer, 35
 raising, 151
 Starling, 35
 Strassers, 35
 Swallows, 35
 time female sits, 157
 male sits, 157
 Trumpeters, 35
 Turbits, 35
 White Kings, 35
 Pigment, yolk, 330
 Piles, 87
 Plans for brooder, 444
 for cellar, 452
 for houses, 173
 for incubator, cellar, 452
 Plant growth, 250
 Plumage, 25
 Plymouth Rock, 45
 Barred, 45
 Buff, 45
 Columbian, 45
 Partridge, 45
 Penciled, 45
 Silver, 45
 Poisoning, 223
 Polish Bantams, 73
 Bearded, 66, 73
 Buff Laced, 73
 Golden, 67
 Silver, 67
 White, 67
 Non-bearded, 67
 Golden, 67
 Polish Non-bearded, Silver, 67
 White, 67
 Crested Black, 67
 Polyneuritis, 274
 Portable poultry house, 199
 Poulard, 25
 Poult, 25
 feeding, 336
 Poultry, 25
 accountant work, 529
 breeder, 25
 club, 185
 dressed shipment, 470
 farm, 204
 plan, 204
 trees, 209
 house, construction, 516
 equipment, 516
 plans, 516
 portable, 199
 unit system, 180, 189
 raiser, 25
 Poultryman, 25
 Precocity, 105
 Preparing birds for show, 361
 Prepotency, 82, 103
 Preserving eggs, 472
 drying, 473
 freezing, 473
 oil, 473
 water glass, 472
 Primaries, 26
 Problems of mating, 82
 Production of eggs, 141
 Progeny, 25
 Protein, 26, 252
 amino-acids, 257, 272
 animal, 278
 Provender, 26
 Proventriculus, 254
 Puberty, age of, 26
 Pubic bones, 26
 Pullet, 26
- Q
- QUILL, 26
- R
- RACING homers, 151
 Raising squabs, 151
 Range, 187

- Rations, 315
 for chicks, 315, 331
 for ducks, 337
 fattening, 356
 geese, 337
 guineas, 347
 laying hens, 317
 pigeons, 347
 poult, 336
 turkeys, 336
- Record cards, 525
 pigeons, 158
- Red Caps, 64
 dog flour, 283
- Refrigerating cars, 471
 dressed poultry, 378
 eggs, 476
- Respiration, 26, 125
 organs, 165
- Rhode Island Reds, 31, 52
 Rose Comb, 31, 52
 Single Comb, 31, 52
- Rhythm of egg production, 97
- Rice, 285
 bran, 285
 hulls, 285
 polish, 285
- Rice's arch of poultry success,
 97
- Roaster, 366
- Rooster, 26
- Rose Comb, 26
 Anconas, 61
 Bantams, 71
 Black Minorcas, 60
 Brown Leghorn, 58
 Buff Leghorn, 58
 Dominiques, 54
 Red Caps, 64
 Rhode Island Red, 52
 White Leghorn, 58
- Round worm, 241
- Roup, 234
- Runner Duck, 76
- Rutabaga, 26
- Rye, 283
 by-products, 283 .

S

- SADDLE, 26
- Salt, 277
- Sanitation, 161, 210
- Sanitary water containers, 212

- Sarcoptes mutans variety gallinæ,
 241
- Scabies, 241
- Scald picking, 373
- Scaly legs, 241
- Score card for dressed poultry,
 391
 for judging layers, 111
- Scrape for dropping boards, 522
- Scratch feed, 323
 evening, 323
 morning, 323
- Sebright Bantams, 71
 Golden, 71
 Silver, 71
- Secondaries, 26
- Secretion, 261
- Selecting birds for breeding, 87
 Barred Plymouth Rock,
 91
 Brahmas, 89
 Cochins, 88
 Hamburgs, 94
 Houdans, 94
 Leghorns, 94
 Rhode Island Red, 92
 Wyandottes, 93
 breeding pigeons, 157
 for egg production, 96
 for meat quality, 113
 sitting eggs, 400
- Serrated, 26
- Serration, 26
- Setting goose eggs, 341
- Shade, 211
- Shaft, 26
- Shafting, 26
- Shank, 27
- Shaping board, 361, 362
 dressed fowls, 374
- Shipping boxes, 384
 crates, 362
 fattened poultry, 361, 362
 live poultry, 477
 pigeons, 159
 shrinkage, 477
- Sick birds, 218
 care of, 218
- Sickles, 27
- Side sprigs, 27
- Silage, 27, 292
- Silkie, 74
- Silo, 27
- Silver, 45

- Silver, Campine, 33, 68
 Duckwing Game, 69
 Bantam, 70
 Gray Dorking, 61
 Leghorn, 58
 Penciled Hamburg, 67
 Plymouth Rock, 45
 Wyandotte, 45
 Sebright Bantams, 71
 Spangled Hamburg, 67
 Wyandotte, 45
 Single Comb, 27
 Ancona, 61
 Black Leghorn, 58
 Minorca, 60
 Orpington, 63
 Brown Leghorn, 58
 Buff Leghorn, 58
 Orpington, 63
 Rhode Island Red, 52
 White Leghorn, 58
 Minorca, 60
 Orpington, 63
 Sitting, coop, 412
 ducks, 424
 eggs, 400, 401
 geese, 424
 hen, 408
 testing, 409
 turkey hen, 423
 Slate turkey, 74
 Small round worm, 241
 Smears eggs, 462
 Smut of corn, 312
 of oats, 312
 Soda glycocholate, 258
 taurocholate, 258
 Soft roasters, 366
 Solid color, 27
 Sore mouth, 222
 Sorghum, 27
 Source of water, 161
 Soybean meal, 27, 289
 Spangle, 27
 Spangles, 27
 Spanish, White-faced Black, 60
 Speckled Sussex, 64
 Spiroptera Hamulosa, 246
 Spleen, 255
 Spoiled feed, 308
 Spot rot, 491
 Spray pumps, 216
 Spraying, 211, 216
 Spring chicken, 27
 Sprouting oats, 293
 Spur, 27
 Squab, 27
 broiler, 27
 raising, 151
 Squirrel tail, 27
 Stag, 29
 Stained eggs, 465
 Starch, 252
 Steapsin, 256
 Stewing chicken, 29
 Sticking knife, 369
 Stipple, 29
 Stock, 29
 Stomatitis, 222
 Storage bin, 516, 521
 construction, 479
 dressed poultry, 476
 eggs, 27, 476
 room, 477
 house, 479
 Strain, 29
 Strawberry comb, 29
 Strength of egg shell, 404
 Study outline, 37
 Succulent feed, 29, 292
 Succus entericus, 257, 261
 Sugar, 252
 Sultans, 74
 Sumatras, 70
 Black, 70
 Sussex, 64
 Red, 64
 Speckled, 64
 Swedish Duck, 76
 Blue, 76
 Sweet corn, 280
 Symmetry, 29
 Syngamus trachealis, 246
- T
- TAIL coverts, 29
 feathers, 29
 Tapeworm, 248
 Taurocholate of soda, 258
 Tenebrio, forma, 314
 Thighs, 29
 Throwing back, 29
 Thumb mark, 29
 Time of hatching, 144, 145
 Toe feathering, 29
 marking, 144
 picking, 220

- Toulouse goose, 79
 Gray, 79
 Trap nest, 517
 construction, 517
 records, 135, 136, 137
 Trees for poultry yards, 209
 Trio, 29
 Trombidium holosericeum, 239
 Trussing, 386
 boning, 389
 Lancashire method, 387
 roasters, 387
 Sussex method, 389
 Trypsin, 256
 Tuberculin, 232
 intradermal test, 232
 Tuberculosis, 232
 Turkey class, 74
 age of laying, 148
 Black, 74
 Bourbon, 74
 Bronze, 74
 Buff, 74
 feed, 149
 feeding, 336
 housing, 149
 Narragansett, 74
 number of eggs laid, 148
 of hens to mate with one
 tom, 149
 selecting for breeding, 148
 sitters, 148
 size of nests, 148
 Slate, 74
 White, 74
 Turnips, 292
 Twisted comb, 29
 feathers, 29
 Types of combs, 28
 Typical, 29
- U
- UNDER color, 29
 Unit system house, 189
 construction, 189
 Up-to-date poultry plant, 204
 Uric acid, 260
 Urine, 263
 Ustilago carbo, 312
 maydis, 312
 Utility classification, 95
 judging, 113
 poultry, 29

V

- VACATION, 29
 bird, 109
 Value of egg crop of U. S., 18
 Variation, discontinuous, 125
 Variety, 20
 Barred, 43
 Black, 44
 Blue, 44
 Brown, 44
 Buff, 43
 classification, 39
 Columbian, 43
 Dark, 44
 Golden, 43
 Light, 44
 Mottled, 44
 Penciled, 43
 Partridge, 43
 Red, 44
 Pyle, 44
 Silver, 43
 Gray, 44
 Spangled, 44
 Speckled, 44
 White, 43
 Velvet bean meal, 289
 Vent, 30
 Ventilation, 168, 169
 amount required, 168
 by diffusion, 170
 draft, 171
 methods, 168, 169
 windows, 171
 Vermin, 236
 Vice, 219
 egg eating, 219
 feather pulling, 220
 toe picking, 220
 Vigor, 138
 Villi, 262
 Vitamines, 272, 274
 Vulture hocks, 30
 V-shaped comb, 30
- W
- WATER, 161
 containers, 212
 fountains, 213
 in body, 274
 source, 161
 troughs, 212

- Wattles, 30
 Web, 30
 Weights and measures, 307
 of barley, 284
 of buckwheat, 236
 of corn, 281
 of oats, 285
 of rice, 285
 of rye, 283
 of wheat, 283
 Wheat, 282
 by-products, 282
 White Booted Bantams, 71
 Call Ducks, 77
 Cochins, 57
 Bantams, 71
 corn, 280
 Cornish, 65
 Crested, Black Polish, 66
 Duck, 77
 diarrhea, 230
 Dorking, 61
 ear lobes, 40
 face, 28
 Faced Black Spanish, 60
 Games, 69
 Bantams, 70
 Guineas, 34
 Hamburgs, 67
 Houdans, 67
 Japanese Bantam, 74
 Laced Red Game Bantams, 70
 Langshan, 57
 Leghorn, 58
 Minorca, 60
 Muscovy Duck, 77
 White Plymouth Rock, 46
 Rose Comb Bantam, 71
 Toulouse Goose, 79
 Turkey, 74
 Wyandotte, 50
 Wild Goose, 79
 Wing bar, 30
 bay, 30
 bow, 30
 coverts, 30
 fronts, 30
 points, 30
 Wire fence, 204
 Worms, 246
 Wort, 283
 Wry tail, 30
 Wyandotte, 31, 48
 Black, 31, 48
 Buff, 31, 48
 Columbian, 31, 48
 Golden, 31, 48
 Partridge, 31, 48
 selection for mating, 93
 Silver, 31, 48
 Penciled, 31, 48
 White, 31, 48

 Y
 YARD, drainage, 211
 feet per bird, 188
 Yellow corn, 280
 Yolk pigment, 330

 Z
 ZYGOTE, 117

