

RURAL TEXT-BOOK
SERIES



THE
PRINCIPLES OF
PLANT CULTURE



GOFF
MOORE & JONES

L. H. BAILEY
EDITOR

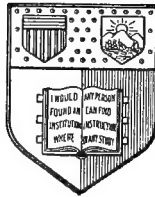

New York
State College of Agriculture
At Cornell University
Ithaca, N. Y.

Library

Gift of
H. J. Roberts.

Cornell University Library
SB 93.G61 1916

The principles of plant culture; a text f



3 1924 000 414 031

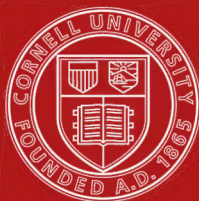

Cornell University Library

The original of this book is in
the Cornell University Library.

There are no known copyright restrictions in
the United States on the use of the text.

<http://www.archive.org/details/cu31924000414031>

The Rural Text-Book Series

EDITED BY L. H. BAILEY

THE PRINCIPLES OF PLANT CULTURE

The Rural Text-Book Series

EDITED BY L. H. BAILEY

- Carleton*, THE SMALL GRAINS.
B. M. Duggar, PLANT PHYSIOLOGY, with special reference to Plant Production.
J. F. Duggar, SOUTHERN FIELD CROPS.
Gay, THE BREEDS OF LIVE-STOCK.
Gay, THE PRINCIPLES AND PRACTICE OF JUDGING LIVE-STOCK.
Goff, THE PRINCIPLES OF PLANT CULTURE, Revised.
Harper, ANIMAL HUSBANDRY FOR SCHOOLS.
Harris and Stewart, THE PRINCIPLES OF AGRONOMY.
Hitchcock, A TEXT-BOOK OF GRASSES.
Jeffery, TEXT-BOOK OF LAND DRAINAGE.
Livingston, FIELD CROP PRODUCTION.
Lyon, Fippin and Buckman, SOILS — THEIR PROPERTIES AND MANAGEMENT.
Mann, BEGINNINGS IN AGRICULTURE.
Montgomery, THE CORN CROPS.
Piper, FORAGE PLANTS AND THEIR CULTURE.
Warren, ELEMENTS OF AGRICULTURE.
Warren, FARM MANAGEMENT.
Wheeler, MANURES AND FERTILIZERS.
White, PRINCIPLES OF FLORICULTURE.
Widsoe, PRINCIPLES OF IRRIGATION PRACTICE.

THE PRINCIPLES OF PLANT CULTURE

A TEXT FOR BEGINNERS IN
AGRICULTURE AND
HORTICULTURE

BY THE LATE

E. S. GOFF

REVISED BY

J. G. MOORE AND L. R. JONES
OF THE UNIVERSITY OF WISCONSIN

EIGHTH EDITION

New York
THE MACMILLAN COMPANY

1916

All rights reserved

©
COPYRIGHT, 1897,

By E. S. GOFF.

COPYRIGHT, 1906,

By C. F. CRONK.

Administrator Goff Estate.

REVISED EDITION

COPYRIGHT, 1916,

By THE MACMILLAN COMPANY.

Set up and electrotyped. Published March, 1916.

Norwood Press

J. S. Cushing Co. — Berwick & Smith Co.
Norwood, Mass., U.S.A.

PREFACE

THIS book, "The Principles of Plant Culture," was first published by the late Professor Goff at Madison, Wisconsin, in 1897. It was then a book of 276 pages. Under his hand and the hands of his associates, Frederic Cranefield and James G. Moore, it has had seven editions; and it has undergone three partial revisions. The sixth edition, appearing in 1910, and the seventh edition, appearing in 1912, ran only to 303 pages, as it had been the desire of all those persons associated with it to keep the volume within comfortable limits. In the present edition the subject-matter has not been increased to any extent, although the page is in different form.

The motive of the book is well stated by Professor Goff in the first edition: "This book has grown out of the author's experience in the lecture room and laboratory, while giving instructions to students in the Short Course in Agriculture, in the University of Wisconsin. It is intended especially for students who have had little or no previous instruction in botany, and it is hoped that it may also be found interesting and profitable to the general reader who would learn more of the principles that underlie the culture of plants."

The book has had the test of use by many teachers and students through nearly twenty years, and it was also the outgrowth of active teaching by a good teacher. It has now had the great advantage of revision and

confirmation by L. R. Jones, Professor of Plant Pathology, and by J. G. Moore, Professor of Horticulture, in the College of Agriculture of the University of Wisconsin, each of whom has been desirous to retain the method and spirit of the original author. The book had been a labor of love on the part of Professor Goff and his wife; and the son, Moulton B. Goff, now a farmer in Wisconsin, has arranged that the work shall be perpetuated.

Emmett Stull Goff was born at Elmira, New York, in 1852, and died at Madison, Wisconsin, in 1902. He was reared on the farm. On the establishing by the State of the Agricultural Experiment Station at Geneva, N. Y., he was elected horticulturist, in which capacity he continued until 1889, when he was elected to the chair of horticulture in the University of Wisconsin, where he remained. At Geneva he established a record for thorough and patient work and was accorded the confidence of the people of the State. He was an early investigator in plant-breeding, in the study of varieties of vegetables, and in the uses and applications of insecticides and fungicides. In the First Annual Report of the Station, Director Sturtevant wrote: "On March 17, [1882] Mr. E. S. Goff arrived to serve as horticulturist, and has proved a thoughtful, earnest, industrious man, whose services derive value through the thoughtfulness and intelligence displayed." Professor S. A. Beach, now of the Iowa State College, found the horticultural work at Geneva in progressive condition when he took it up as Professor Goff's successor. He calls particular attention to the plant-breeding investigations: "A single illustration of his habit of careful and thoughtful observation may be of interest in this connection. In the report of the station for the next

year, 1883, page 206, Professor Goff records an observation of the fact of dominance and recessiveness in certain characters of the common garden pea, although he did not know Mendel's discovery. This was seventeen years before the rediscovery of Mendel's Law by de Vries, Tschermak, and Correns. After mentioning the cross fertilization of several different varieties of peas in 1882, he states: 'The seeds resulting from these crosses, which were planted May 12, [1883] vegetated rather poorly, but the plants were all vigorous, and a few of them were very prolific, the largest yield from one plant being sixty-one pods. We noted that in crossing wrinkled with smooth varieties, peas of both sorts were mixed indiscriminately in the pods, while the pods themselves were of the type of either parent, or were sometimes intermediate in form; but in crossing the common varieties upon the sugar-pea, the peas of the two types were in no case mixed in the pods. The pods were always of the type of the common pea, though on certain plants all of the peas that they enclosed were of the sugar type.'

At the University of Wisconsin his work was successful and well appreciated. For this preface, Dr. W. A. Henry, formerly Dean of the College of Agriculture there and now Professor Emeritus, makes the following appreciative statement: "Professor Goff held no college diploma, but he was a trained scientist nevertheless, and a gentleman of the highest type. He combined the qualities of a real investigator with those of a delightful teacher. He was loved by all. He grew into his strength under the guidance of Sturtevant at the New York [Geneva] Experiment Station in intimate association with Babcock, Ladd, Plumb, and other worthy associates. Following Babcock to Wisconsin,

he continued to grow and increase in mentality and usefulness as he conducted his researches and instruction at the Station and College. Just at the time he reached his majority as a worker in the rapidly expanding field of agricultural research and instruction, he was taken from us and American horticulture lost one of its ablest and staunchest teachers and investigators."

I wish to add my personal testimony to the real worth of Professor Goff. Although he left New York soon after I entered it, I leaned heavily on him and his work, and continued an association that had been formed some years before. He was always the clear thinker, the patient seeker, the considerate and careful friend.

L. H. BAILEY.

ITHACA, N. Y.,
January 1, 1916.

CONTENTS

CHAPTER I

	PAGES
INTRODUCTION	1-13
Close observation, 1 ; The difference between art and science, 2 ; Environment, 3 ; What is plant culture ? 4 ; Domestic or domesticated plants or animals, 5 ; Culture aims to improve nature's methods, 6 ; Culture deals with life, 7 ; What is life ? 8 ; Vigor and feebleness, 9 ; Hardiness and tenderness, 10 ; Health and disease, 11 ; The cellular structure of living beings, 12 ; Protoplasm, 13 ; Reserve food, 14 ; Growth, 15 ; Reproduction, 16 ; Reproduction either sexual or non-sexual, 17 ; Heredity and variation, 18 ; The principle of selection, 19 ; Breeding, 20 ; Classification, 21 ; Scientific names, 22 ; Crosses and hybrids, 23 ; The theory of evolution, 24 ; Parasites, 25.	

CHAPTER II

THE SEED, GERMINATION AND THE PLANTLET	14-33
Seeds absorb water, 26 ; The rate at which seeds absorb water, 27. <i>Germination</i> : What is germination ? 28 ; Moisture essential to germination, 29 ; Warmth essential to germination, 30 ; Free oxygen essential to germination, 31 ; Prompt germination important, 32 ; Compacting the soil, 33 ; Warm soil, 34 ; Soaking seeds, 35 ; Cracking seed-case, 36 ; Failure to germinate, 37 ; Seed testing, 38 ; The time required for germination, 39. <i>The Plantlet</i> : The hypocotyl, 40 ; The seed-case in germination, 41 ; Seeds of the pumpkin family, 42 ; Some plantlets need help to burst the seed-cases, 43 ; The roots, 44 ;	

The cotyledons, 45 ; Development of hypocotyl, 46 ; Shallow planting, 47 ; The vigor of the plantlet, 48 ; Vigorous seedlings, 49 ; How deep should seeds be planted ? 50 ; Surface planting, 51 ; Spores, 52 ; The embryo, 53 ; The endosperm, 54 ; The plumule, 55 ; Parts of the seedling, 56.

CHAPTER III

THE GROWING PLANT 34-57

Chlorophyll, 57 ; Formation of food, 58 ; The sources of plant-food, 59 ; Elements in plant-food, 60 ; Function of the different elements, 61 ; Water is necessary to growth, 62 ; Distribution of food materials through the plant, 63. *The inner structure of the plant* : The epidermis, 64 ; Breathing pores or stomata, 65 ; The growing point, 66 ; The vascular bundles, 67 ; The cambium layer, 68 ; Uniting of the cambium, 69 ; How stems increase in diameter, 70 ; The living part of woody stems, 71 ; The healing of wounds, 72. *The water of plants and its movements* : Water-content of plants, 73 ; Transpiration, 74 ; Influence of trees, 75 ; The brittleness, 76 ; The transpiration current, 77 ; The flow of sap in spring, 78 ; The current of prepared food (elaborated sap), 79 ; Killing trees by girdling, 80 ; Root starvation, 81 ; Weed destruction, 82 ; Restriction, 83 ; The storage of reserve food, 84 ; Use of reserve food, 85.

CHAPTER IV

THE ROOT AND THE SOIL 58-74

Functions of the root, 86 ; Origin of the root, 87 ; Moisture, 88 ; Oxygen, 89 ; The ideal soil, 90 ; Changes in the soil, 91 ; The importance of organic matter in the soil, 92 ; Soil ventilation, 93 ; Ventilation of hotbeds, 94 ; Soil aëration, 95 ; Potted plants require drainage, 96 ; Watering potted plants, 97 ; How the root-tip penetrates the soil, 98 ; Growth of roots in length, 99 ; The root-hairs, 100 ; Absorption of water, 101 ; Parts that absorb, 102 ; The branching of roots, 103 ; Transplanting and

root pruning, 104 ; Pricking off, 105 ; Nursery trees, 106 ; Root pruning, 107 ; The horizontal extent of roots, 108 ; Depth of roots in the soil, 109 ; The rate of root growth, 110 ; Relation of roots to food supply, 111 ; Root tubercles, 112. *The stem* : The parts, 113 ; The stem, 114 ; Nodes and internodes, 115 ; Lengthening of stem, 116 ; Length of internodes, 117 ; The stem elongates faster, 118 ; Pinching, 119.

CHAPTER V

LEAVES, BUDS, AND FLOWERS 75-95

The leaves : The function of leaves, 120 ; Leaf development, 121 ; Distance apart to grow plants, 122 ; Number of leaves, 123 ; The comparative size of leaves, 124 ; Life of a leaf, 125 ; The manurial value of leaves, 126. *The buds* : The buds, 127 ; Lateral buds, 128 ; Branches, 129 ; Adventitious buds, 130 ; Leaf-buds and flower-buds, 131 ; Differences between leaf- and flower-buds, 132 ; Vigor of leaf-buds, 133 ; Conditions affecting the formation of flower-buds, 134 ; Promoting accumulation of plant-food, 135 ; Pinching to promote flowering, 136 ; Ringing, 137. *The flower* : The flower, 138 ; Effect of flowers, 139 ; Parts of the flower, 140 ; The calyx, 141 ; The corolla, 142 ; The stamens, 143 ; The pistil, 144 ; Variation in form, 145 ; Abortive parts, 146 ; Composite flowers, 147 ; The flowers of the grass family, 148 ; Fecundation, 149 ; Pollination, 150 ; Cross-pollination, 151 ; Advantages of cross-pollination, 152 ; Perfect, monoëcious, and diëcious flowers, 153 ; Planting with reference to pollination, 154.

CHAPTER VI

THE FRUIT AND THE SEED 96-103

Development of fruit, 155 ; Exhausting the plant, 156 ; Prevention of seeding, 157 ; Overbearing, 158 ; Thinning, 159 ; Seeding of fodder crops, 160 ; Ripening of fruits, 161. *The gathering and storing of seeds* : Time of germination, 162 ; Immature *versus* ripe seeds, 163 ;

Length of seed viability, 164 ; Conditions affecting the duration of seed viability, 165 ; Moisture, 166 ; Age of seed as affecting the resulting crop, 167 ; Effect of drying on vitality of seeds, 168 ; Stratification of seeds, 169.

CHAPTER VII

THE DECLINE OF GROWTH AND THE REST-PERIOD . . . 104-108

Cessation of growth, 170 ; Occurrence of the rest-period, 171 ; Greenhouse plants, 172 ; Maturity, 173 ; Hardiness, 174 ; Acclimatizing, 175 ; Plant processes, 176 ; Cuttings, 177 ; The "turn of the year," 178 ; The round of plant life, 179.

CHAPTER VIII

THE PLANT AS AFFECTED BY UNFAVORABLE TEMPERATURE 109-128

Factors of environment, 180. *The plant as affected by excessive heat*: Relation of heat to transpiration, 181 ; Effect of heat on evergreens, 182 ; High temperatures, 183 ; Sprinkling in sunshine, 184 ; Sun-scald, 185 ; Tip-burn of potatoes, 186. *The plant as affected by excessive cold*: Effect of cold, 187 ; Relation of water to freezing, 188 ; The power of plants to endure cold, 189 ; Treatment of frost-injured plant tissues, 190 ; Destruction of terminal buds by cold, 191 ; The darkening of the wood, 192 ; Splitting of wood, 193 ; Bark-bursting, 194 ; Root-killing of trees, 195 ; Killing of flower-buds, 196 ; Killing of flowers, 197 ; Destruction by ice, 198 ; Heaving, 199. *Methods of averting injury by cold during the dormant period*: Dry soil, 200 ; Pinching the terminal buds, 201 ; Protection with non-conducting materials, 202 ; Exposure, 203. *Methods of averting injury from cold in the growing period*: The freezing point, 204 ; The cause of hoarfrost, 205 ; Foretelling frost, 206 ; The sling psychrometer, 207 ; Computing the dew point, 208 ; Use of weather maps in predicting frost, 209 ; Cold-air drainage, 210 ; Factors tending to avert frost, 211 ; Influence of a body of water,

212 ; Localities subject to frosts, 213 ; Thermal belts, 214 ; Liability to frost, 215 ; Methods of preventing injury by frost, 216.

PAGES

CHAPTER IX

THE PLANT AS AFFECTED BY WATER. 129-136

Destruction of roots, 217 ; Injudicious watering, 218 ; Watering, 219 ; Rapidly-growing plants, 220 ; Water requirement of plants, 221 ; Dropsical condition, 222 ; Water sprouts, 223 ; Cracking, 224 ; Knobby potatoes, 225 ; Air moisture, 226. *The plant as affected by insufficient water* : Excessive transpiration, 227 ; Retarding growth, 228 ; Hastening maturity, 229 ; Toughness of plant tissues, 230 ; Cultivation of the soil, 231 ; Mulching, 232 ; Irrigation, 233 ; Drying, 234.

CHAPTER X

THE PLANT AS AFFECTED BY UNFAVORABLE LIGHT AND WIND 137-143

Excessive light : Shading plants, 235 ; Cauliflower heads, 236. *Plants as affected by insufficient light* : Abnormal development, 237 ; Close planting, 238 ; Weeds, 239 ; Plants under glass, 240 ; The electric light, 241 ; Insufficient pruning, 242 ; Blanching, 243. *Plants as affected by excessive wind* : Preventive measures, 244. *Plants as affected by insufficient wind* : Fungous attacks, 245 ; Frost damage, 246 ; Pollination, 247.

CHAPTER XI

THE PLANT AS AFFECTED BY UNFAVORABLE FOOD SUPPLY 144-151

Excessive food : Excess of most foods, 248 ; Excessive nitrogen, 249. *Plants as affected by insufficient food* : Lack of food and water, 250 ; Dwarfing of plants, 251 ; Reducing plant-food, 252 ; Deficient food elements, 253 ; Importance of nitrogen, 254 ; The sources of nitrates, 255 ; The conditions affecting nitrification, 256 ; Soil aëration, 257 ; Partially-decomposed organic manures,

258; Value of legumes, 259; Value of rain and snow, 260; Nitrogen, 261; Phosphorus, 262; Potassium, 263; Wood ashes, 264; Nitrogenous fertilizers, 265; Signs of lack of food, 266; Crop rotation, 267; A growing crop, 268; Manures, 269.

CHAPTER XII

PLANTS AS AFFECTED BY ANIMAL PARASITES . . . 152-172

Classes of parasites, 270; Mice, 271; Gophers, 272; Rabbits, 273; Woodchucks, 274; Birds, 275; Useful insects, 276; Preventive methods, 277; Inclosing the plants, 278; Trapping, 279; Repelling insects, 280; Hand picking, 281; Poisoning, 282; The arsenic compounds, 283; Paris green, 284; Arsenite of lime, 285; Arsenate of lead, 286; Other arsenites, 287; Poisons, 288; Hellebore powder, 289; Pyrethrum powder, 290; Keeping these powders, 291; Tobacco smoke, 292; Tobacco solutions, 293; Kerosene, 294; Lime sulfur wash, 295; Resin (or rosin) washes, 296; Hydrocyanic acid gas, 297; Fir-tree oil, 298; Hot water, 299; Number of insects, 300; The chinch-bug, 301; The army-worm, 302; Grasshoppers and locusts, 303; Apparatus for applying insecticides, 304; The use of insecticides, 305; Classes of insects, 306; The eating insects, 307; The leaf-eaters, 308; The root-eaters, 309; Burrowers, 310; Borers, 311; Leaf-miners, 312; The codlin-moth, 313; The plum curculio, 314; Destroying fruit, 315; Sucking insects, 316; The life histories, 317.

CHAPTER XIII

PLANTS AS AFFECTED BY VEGETABLE PARASITES AND BY WEEDS . . . 173-185

Types of vegetable parasites, 318; The broom rape, 319; The dodders, 320; Parasites of the lower orders, spore plants, 321; Methods of controlling plant diseases, 322; Destruction of the affected parts, 323; Infection may be prevented, 324; Soil treatment, 325; Soil ster-

ilization, 326; Seed treatments, 327; Spraying, 328; Fungicides, 329; Bordeaux mixture, 330; Ammoniacal solution of copper carbonate, 331; Lime sulfur, 332; Other forms of sulfur, 333; Non-parasitic diseases, 334; Resistance to disease, 335; Weeds, 336; Kinds of weeds, 337; Annual and biennial weeds, 338; Perennial weeds, 339.

CHAPTER XIV

THE PROPAGATION OF PLANTS. — BY SEEDS, DIVISION AND CUTTING 186-213

Propagation, 340; Methods of propagation, 341; Propagation by seeds, 342; Propagation by division, 343; Methods of propagation by divisions, 344; Propagation by parts intact, 345; Propagation by suckers, 346; Propagation by stolons, 347; Propagation by layers or layering, 348; Propagation by division of the crown, 349; Propagation by detached parts, 350; Propagation by specialized buds, 351; The bulb, 352; Bulb-lets, 353; The corm, 354; The tuber, 355; Planting, 356; Propagation by sections of the plant, 357; Propagation by cuttings, 358; Ease of propagation by cuttings, 359; Characteristics of a cutting, 360; Parts used for cuttings, 361; Conditions that favor the growth of cuttings, 362; Methods for controlling temperature, 363; The coldframe, 364; The hotbed, 365; The greenhouse, 366; Heating greenhouses, 367; The propagating-bed, 368; Methods of controlling humidity, 369; Propagation by cuttings from dormant plants, 370; The storage of cuttings, 371; Planting cuttings in autumn, 372; Stem cuttings, 373; Length of stem cuttings, 374; How to plant stem cuttings, 375; Propagation from cuttings of the root, 376; Propagation by cuttings from active plants (green cuttings, slips), 377; Care in making green cuttings, 378; Kinds of green cuttings, 379; How to make green cuttings of herbaceous plants, 380; How to make green cuttings of woody plants, 381; Propagation by leaf cuttings, 382.

CHAPTER XV

PAGES

PROPAGATION BY GRAFTING 214-230

Grafting, 383; Objects of Grafting, 384; The plants that unite by grafting, 385; Cion-grafting, 386; Grafting wax, 387, Grafting cord, 388; Grafting paper, 389; Tongue-grafting, 390; Root-grafting, 391; Cleft-grafting, 392; Side-grafting, 393; Budding, 394; Success in budding, 395; T-budding, 396; The budding knife, 397; Ring-budding, 398; Approach-grafting, 399.

CHAPTER XVI

TRANSPLANTING 231-247

Transplanting, 400; Time to transplant, 401; Lifting the plant, 402; Lifting large trees, 403; Sacking, 404; Removing the plant, 405; Puddling, 406; Bundling, 407; Unpacking and heeling-in, 408, Replanting, 409; Replanting the roots, 410; Devices for transplanting, 411; Potting and shifting, 412; Mulching, 413; Shading, 414; Tardy starting into growth, 415.

CHAPTER XVII

PRUNING 248-264

Pruning, 416; The season for pruning, 417; Making the cut, 418; Unhealed wounds, 419; Objects of pruning, 420; Formative pruning, 421; Symmetry and picturesqueness, 422; Stockiness and slenderness, 423; Pruning for density, 424; Pruning for strength, 425; Stimulative pruning, 426; Pruning for growth, 427; Pruning for flowers or fruit, 428; Protective pruning, 429; Maturative pruning, 430; Pruning implements, 431.

CHAPTER XVIII

PLANT-BREEDING 265-274

Improvement of plants under culture, 432; Causes of improvement, 433; Variability, 434; Reversion, 435;

CONTENTS

xvii

How to fix desirable variations, 436 ; Seed selection, 437 ;
Inducing variation, 438 ; Selection of subjects for crossing,
439 ; Cross-fecundation, 440 ; Preparing the flower for
crossing, 441 ; To prevent undesired pollination, 442 ;
The after-care of crosses, 443 ; The selection of crossed
seedlings, 444 ; Planting with reference to chance
crossings, 445 ; Plant-breeders are benefactors, 446.

PAGES

APPENDIX

A SYLLABUS OF LABORATORY WORK 275-285

LIST OF ILLUSTRATIONS

FIGURE	PAGE
1. Protococcus plants	5
2. Spirogyra filament	5
3. Apple leaf in section, showing cells	6
4. Germination of beans, showing need of oxygen	19
5. Germination of rice, showing need of oxygen	20
6. Seed-tester	23
7. Germinating pumpkin seed	26
8. Plantlet of pumpkin	27
9. Plantlet of Indian corn	27
10. Plantlet of bean	27
11. Plantlet of pea	27
12. Bean plantlets which have lost their cotyledons	29
13. Radishes grown from heavy and light seed (Bailey)	30
14. Cross-section of germinating Indian corn grain (Frank)	32
15. Cross-section of leaf of beech (Strasburger)	35
16. Starch in potato cell	36
17. Section of apple leaf	41
18. Stomata on leaf of garden beet (Frank and Tschirch)	42
19. Stomata on apple leaf	43
20. Prosenchyma cells from stem of rye (Frank and Tschirch)	44
21. Cross-section of vascular bundle of sunflower (Prantl)	45
22. Transverse section of corner of bean stem (Potter)	46
23. Live poplar tree with hollow trunk	48
24. Healing of wound formed by cutting off a branch	49
25. Callus at base of willow cutting	49
26. Dwarfing of crop by a spruce hedge	51
27. Slips of Tradescantia	60
28. Roots of wheat plant, showing root-hairs (Frank and Tschirch)	64
29. Turnip seedling, showing root-hairs (Frank and Tschirch)	65
30. Root-hair magnified with adhering particles of soil (Sachs)	65

FIGURE	PAGE
31. Root branching stimulated by pruning	67
32. Celery plants, showing effect of transplanting on root growth (Green)	68
33. Young clover plant, showing tubercles on roots	69
34. Potato plant, showing old tuber and the different parts	71
35. Nodes of box elder and wild grape	72
36. Twig showing union of new and older wood	73
37. Lateral buds (Barry)	79
38. Flower-buds of Pottawattamie plum	81
39. Fruiting branch of European plum (Barry)	81
40. Fruiting branch of Morello cherry (Barry)	81
41. Leaf-buds of apple (Barry)	81
42. Fruit-bud of apple (Barry)	81
43. Fruit-spurs of apple (Hardy)	84
44. Fruit-spur of pear (Barry)	88
45. Section of cherry blossom	88
46. Flower of the pea (Baillon)	89
47. Flower of the pea dissected (Figuier)	89
48. Stamens and pistil of the pea (Baillon)	89
49. Pistil of the pea (Baillon)	89
50. Cross-section of flower-head of sunflower	90
51. Enlarged floret of sunflower	91
52. Ray-flower of sunflower	91
53. Spikelet of wheat (La Maont and Decaisne)	92
54. Spikelet of wheat dissected (Prantl)	92
55. Flower of wheat enlarged (La Maont and Decaisne)	92
56. Imperfect flower of strawberry	95
57. Perfect flower of strawberry	95
58. Sun-scald on silver maple tree	111
59. Trunk of apple tree inclosed in lath screen	112
60. Sling psychrometer	122
61. Lath screen (Bailey)	137
62. Shed screen (Bailey)	138
63. Brush screen (Bailey)	138
64. Board shade for newly set plants	139
65. Fruit branch of apple grown in light (Kinney)	141
66. Fruit branch of apple grown in partial shade (Kinney)	141
67. Screen-covered frame for protecting melon hills	154
68. Sifting-box for applying powders	163

FIGURE	PAGE
69. Bucket sprayer	164
70. Atomizer	164
71. Barrel pump for small orchard	165
72. Good spray outfit for low trees	165
73. Power sprayer for commercial orchard	166
74. Two good types of spray nozzles	167
75. Tared paper cards for protecting stems of young plants	169
76. Tool for cutting cards	169
77. Manner of using tool in cutting cards	169
78. Curculio catcher	171
79. Steam sterilization of greenhouse soil	177
80. Apple-scab on leaves	178
81. Apple-scab on fruit	179
82. Section of apple-scab infection	180
83. Manner of multiplication of sow thistle	183
84. Sucker plant of red raspberry	190
85. Tip plant of black raspberry (Bailey)	190
86. Strawberry runner	191
87. Mound-layering of gooseberry plants (Bailey)	192
88. Layered branch of currant	192
89. Bulb of common onion	193
90. Bulb of garlic	193
91. Bulb of wild lily	193
92. Bulb of lily in longitudinal section	193
93. Bulblets of tiger lily	194
94. Bulblets of "top" onion	194
95. Corm of crocus	194
96. Coldframe	199
97. Cross-section of hotbed (Greiner)	200
98. Cross-section of greenhouse (Greiner)	201
99. Propagating-bed	203
100. Stem cutting of currant (Bailey)	206
101. Stem cutting of grape (Bailey)	206
102. Currant cutting rooted	206
103. Root-cutting of blackberry (Bailey)	208
104. Rooted cutting of coleus (Bailey)	210
105. Chrysanthemum cutting (Bailey)	210
106. Leaf-cutting of begonia (Bailey)	212
107. Grafting knife	218

FIGURE	PAGE
108. Cion used in grafting	218
109. Seedling root for root-grafting	218
110. Cion shaped ready for insertion	218
111. Seedling root shaped to receive cion	218
112. Cion and root put together	218
113. Graft wrapped with grafting paper	218
114. Shaping cions for root-grafting	220
115. Grafting chisel used in cleft-grafting	221
116. Cion shaped for cleft-grafting (Bailey)	222
117. Cions inserted in cleft	222
118. Transverse cross-section of cleft graft (Maynard)	222
119. Branches of tree to be top-grafted	223
120. Cleft-graft in trunk of old grape vine (Bailey)	223
121. Side-graft inserted	224
122. Shoot containing buds (Bailey)	225
123. Bud cut off ready for insertion (Bailey)	225
124. Bud partially inserted (Bailey)	225
125. Bud inserted and tied (Bailey)	225
126. A lesson in budding	227
127. Man budding in nursery row (Bailey)	227
128. Budding-knife with ivory spatula	228
129. Home-made budding-knife	228
130. Two plants prepared for approach grafting	228
131. Two plants bound together for approach grafting (Bailey)	229
132. Plants packed for shipping	235
133. Nursery trees heeled-in	236
134. Puddled roots of nursery tree	236
135. Roots of nursery tree ready for planting	236
136. Roots of tree properly planted	237
137. Roots of tree improperly planted	237
138. Strawberry plant too deeply planted	238
139. Strawberry plant planted too shallow	238
140. Strawberry plant properly planted	238
141. Large transplanted tree protected with hay rope and wire	239
142. Flat steel dibber	240
143. Tool for planting root grafts and cuttings	240
144. Richards' transplanting tool	240
145. A transplanting machine	241
146. Use of dibber in setting plant	242

FIGURE	PAGE
147. Pressing earth about roots with dibber	242
148-151. Successive operations in potting plants	243-244
152. Device for starting growth in trees	245
153. A poorly-potted plant	246
154. A well-potted plant	246
155. A poorly-shifted plant	246
156. Proper place to cut in pruning	250
157. Proper method of removing large branches in pruning	250
158. Pruning to an outside or inside bud	250
159. Pruning for symmetry	252
160. Raspberry cane rendered stocky by pruning	253
161. Raspberry cane not pruned	254
162. Method of disbudding shoots in some conifers	255
163. Dense growth promoted by pinching out terminal buds	255
164. Unpruned apple tree	256
165. Apple tree pruned to open head	257
166. Branches of fruit tree tied together by grafting	258
167. Sear's pruning-saw	262
168. Perfection pruning-saw	262
169. Pruning-knife	262
170. All-steel pruning-shears	262
171. Hedge shears	263
172. Lever shears	263
173. Pole shears	263
174. Raspberry hook	263
175. Instruments for crossing plants	271
176. Emasculated flower inclosed in sack	271
177. Device for weighing and determining volume of seeds	276

PRINCIPLES OF PLANT CULTURE

CHAPTER I

INTRODUCTION

A **SYSTEMATIC** study of plant culture should lie at the beginning of good farming or gardening. One should know the nature of a plant and how it responds to the conditions in which it is placed, and how it is protected and modified. Before undertaking a study of plant culture, however, we may profitably consider a few principles of a more general nature.

1. Close observation offers the best means of gaining knowledge of material things. The habit of accurate discernment, and of studying the relations of and the reasons for things and facts as we find them, should be constantly cultivated. Knowledge once gained must be applied at the proper place, in the proper manner and at the proper time, or the highest success in any calling cannot be expected.

2. The difference between art and science. — Art, as the word is used here, is knowing how to do a thing without reference to reasons. It is practiced by the artisan or workman. Science considers the reasons for doing it. Art implies more or less of skill gained through practice. Science implies a knowledge of the objects to be gained by a given operation and the conditions affecting the process.

An intelligent but untrained person might be taught to prepare and insert a cion (386)¹ in the most approved way. This pertains to the art of grafting. The same person might be taught the reasons why each step of the process is performed in its particular manner. This pertains to the science of grafting. One may become a skilled grafter without learning the science of grafting, but one cannot graft intelligently. The artisan, however skillful, who knows only the art, cannot become a master workman in the highest sense until he learns also the science that underlies his trade.

The art of doing any kind of work is best learned by working under the guidance of a skilled workman. The science is best learned from books and laboratory and field experimental studies with the help of trained instructors. Science not yet wrought out, and hence not explained in publications, is learned by close, persistent and thoughtful investigation.

3. Environment is a term used to express all the outside influences, taken as a whole, that affect a given object in any way. A plant or animal, for example, is affected by various external conditions, as heat, moisture, light, food and so on. These conditions and all others that influence the plant or animal make up its environment.

4. What is plant culture? — The well-being of a plant or animal depends very much upon a favorable condition of environment, and with the proper knowledge, we can do much toward keeping the environment in a favor-

¹ The numbers in parenthesis in the text refer to the numbered paragraphs in this book, and are intended to help students to a better understanding of the subject. Students should be urged to look up these cross-references.

able condition. For example, if the soil in which a plant is rooted lacks plant-food, we can enrich it; if it lacks sufficient moisture, we can dampen it; if the plant is shaded by weeds, we can remove them. These, and any other things that we can do to make the environment more favorable, constitute culture in the broadest sense of the term. A full knowledge of the culture of any plant implies a knowledge, not only of the plant and its needs, but of each separate factor in its environment, and how to maintain this factor in the condition that best favors the plant's development toward some special end, as the production of the finest and highest type of fruit, flowers or seed. We should know, not only the soil that best suits the plant, but the amount of light, moisture, warmth and food in which it prospers best. We should know the enemies that prey upon it, the manner in which they work their harm, and how to prevent their ravages. We should know, in short, how to regulate every factor of environment so as to promote the plant's well-being to the utmost, as well as how to develop every desirable quality the plant possesses.

5. Domestic or domesticated plants or animals are those that are in the state of culture. In nature, different plants and animals struggle with one another for space and food. Only those best adapted to their environment survive, and these are often much restricted in their development. In culture, the intelligence and energy of man produce a more favorable environment for the species he desires to rear; hence domestic plants and animals attain higher development in certain directions than their wild parents. The cultivated potato, for example, grows larger, is more productive and is higher in food value than the wild potato. The finer

breeds of horses and cattle are superior to their wild progenitors in usefulness to man.

6. Culture aims to improve nature's methods rather than to imitate them. By cutting out the superfluous branches from a fruit-tree, we enable the fruit on the remaining branches to reach a higher state of development. By planting corn at the proper distances, we prevent crowding and enable each plant to attain its maximum growth. We should constantly study nature's methods for useful hints in culture, and the culture of a given plant or animal should be based more or less upon its natural growth conditions, but the highest progress would be impossible if we sought only to imitate nature.

7. Culture deals with life. — All the products of culture, whether obtained from the farm, garden, orchard, nursery or greenhouse, proceed directly or indirectly from plants or animals, both of which are living beings. A knowledge of the conditions that sustain and promote life is, therefore, the foundation to a broad knowledge of husbandry.

8. What is life? — We know nothing of life except as it is manifested through the bodies of plants and animals. With these, we can define, within certain limits, the range of environment in which it can exist; we can hinder or favor it; we can apparently destroy, but we cannot restore it. We know that it proceeds from a parental body similar to its own, that the body it inhabits undergoes a definite, progressive period of development, at the end of which the life disappears and the body loses more or less promptly its form and properties.

9. Vigor and feebleness are terms used to express the relative energy manifested by the life of different living beings. Certain trees in the nursery row usually outstrip others in growth, *i.e.*, are more vigorous than others. One

pig in a litter very often grows slower than any of the others, *i.e.*, is more feeble and less vigorous than any of the others. Feebleness is the opposite of vigor. The most vigorous plant or animal usually attains the largest size, and as a rule is most satisfactory to its owner. Vigor is promoted by a favorable environment. It is usually greatest in rather young plants and animals, and declines with advancing age. It may be reduced by disease or improper treatment, and when thus reduced is often difficult to restore. Reduced vigor tends to early maturity and shortened life, and sometimes to increased prolificacy.

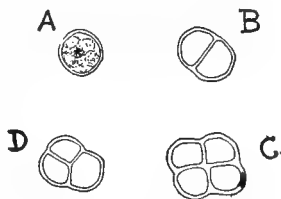

FIG. 1. — Four individual plants of a species of Protococcus. A shows a plant before commencing to divide into other plants. B, C and D show how the cells divide to form other plants. Highly magnified.

10. Hardiness and tenderness are terms used to express the relative power possessed by different plants or animals to endure extremes in their environment. The Oldenburg apple endures with little harm vicissitudes of temperature



FIG. 2. — Part of a filament of a species of Spirogyra, a plant consisting of a single row of cells united at their ends. The places where the cells join are indicated by the vertical lines. Highly magnified.

that are fatal to many other varieties; in other words, it is hardier as regards temperature than many other varieties. The reindeer is hardier as regards cold than the horse, but tenderer as regards heat. The melon plant is hardier as regards heat and drought than the lettuce, but tenderer as regards wet or cold.

11. Health and disease. — A plant or animal is said to be in health when all its organs (parts) are capable of performing their normal functions. An organ incapable of doing this, or the being possessing such an organ, is said to be diseased.

12. The cellular structure of living beings. — A bit of vegetable or animal substance, examined under a microscope of moderately high power, is seen to be made up of numerous little sacks or cavities, more or less clearly defined, called cells.

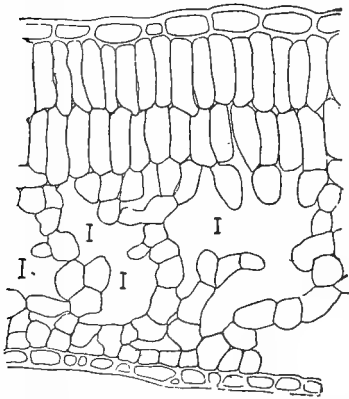

FIG. 3. — Cells of an apple leaf in a section from its upper to its lower surface. Highly magnified. The spaces marked *I* are cavities between the cells.

Cells from different beings, or from different parts of the same being, may vary much in form and size, but they are seldom large enough to be seen without magnifying power. Some of the lowest plants and animals consist of single cells (Fig. 1). Some of the lower plants consist of a single row of cells

united at the end (Fig. 2). The higher plants and animals are made up of many cells united, and in these, the cells assume different forms and properties in the different organs (Fig. 3). In some cases the united cells may be readily separated from one another, which shows each cell to be more or less an independent structure. As a rule, each cell is surrounded by its own closed cell-wall.

13. Protoplasm. — Living cells consist of a transparent, jelly-like substance called protoplasm, which manifests the various phenomena of life. Protoplasm may exist either in an active or dormant state. In the active state it requires both nourishment and oxygen; in the dormant state it may exist for a considerable time with very little of either, and is far less susceptible to external influences than in its active state. The protoplasm contained in plants during their rest period (170), in mature air-dry seeds, and in the lower animals during their torpid condition is in the dormant state. Material is said to be “air-dry” when it is as dry as it will become by exposure to the air at ordinary temperatures.

14. Reserve food. — Active protoplasm may absorb nourishment in excess of immediate requirements and hold it as reserve food. In plants, much of this reserve food is in the form of starch, sugar or oil; in animals, it is in the form of fat. These substances are formed by the protoplasm from its crude food materials (58). The reserve food enables the plant or animal to live through limited periods of scarcity, and to meet the demands necessitated by reproduction (16).

15. Growth is the normal, permanent change in the form of a living vegetable or animal body, and is usually accompanied by increase in size. It may occur either through expansion of cells already formed, or through cell multiplication. The latter may take place either by division of older cells into two or more smaller cells (Fig. 1), or by the formation of new cells within older ones — the young cells thus formed attaining full size by subsequent enlargement.

16. Reproduction is the increase in number of living beings. It is one of the properties of protoplasm and is

essentially a process of division. As living cells multiply by forming new cells, so living beings, which consist of cells, multiply by the separation of a part of their own cells, and this separated group of cells grows into a complete organism like the parent. The higher plants multiply by seeds (155), which are separated from the parent plant, and each of which contains a young plant (53). The eggs from which young birds are hatched contain cells filled with living protoplasm, and the protoplasm of the living young of mammals is separated from the parent before birth. Prolificacy, the ability to reproduce abundantly, varies greatly in both animals and plants. The quail often produces twelve to fifteen young in a single season, while two to four is an average number for the bluebird. Prolificacy is also influenced to a lesser extent by variety.

17. Reproduction either sexual or non-sexual. — Sexual reproduction can take place, as a rule, only upon the union of cells of different sexes. It is not peculiar to the animal kingdom, but occurs in plants also and except in rare cases is necessary to the production of seeds that are capable of germination (28). It is the only method of reproduction in the higher animals. Sexual reproduction does not usually take place until the period of most rapid growth has passed. Non-sexual reproduction is independent of sex. It results from the direct separation of a part of the parent, which under favorable conditions develops into a complete individual. It occurs when plants multiply by means other than by seeds, as by non-sexual spores (52), bulbs (352), stolons (348), cuttings (358), and the like, and it is a common method of reproduction in certain of the lower animals, as plant-lice (Aphids).

18. Heredity and variation. — The offspring of a plant

or animal tends to be like the parent or parents in general characteristics but there are usually evident differences in some respects; no two individuals can be precisely alike. Variation in the offspring may take place in any direction, as in the size or color of the flower, the sweetness or juiciness of the fruit, the prolificacy (16), the vigor (9) or the hardiness (10). It follows that in culture certain individual plants or animals are more desirable to the cultivator than others, because the individuals possess different qualities.

19. The principle of selection. — Since the offspring tends to resemble the parent or parents, we may gradually improve plants or animals in the direction of greater usefulness by selecting the most desirable individuals for reproduction. For example, by saving and planting seeds from the plants that produce the finest petunia or pansy blossoms, we secure finer flowers than if we gather seeds without regard to parentage.

20. Breeding in plants and animals is reproduction, watched over and directed by man, with reference to securing special qualities in the offspring. It is based on the principle that the peculiarities of the parent or parents tend to be reproduced, and may be intensified, in the descendants. But before we are prepared for the study of breeding, we need to know something of the principles of classification.

21. Classification is the arrangement of the different kinds of plants and animals into groups and families based on individual resemblances. If we examine plants as they are growing in nature, we may observe (*a*) that there are many plants of the same kind, and (*b*) that there are many kinds of plants. The different plants or animals of the same kind are called individuals, and, in general,

we may say that the different kinds of plants or animals are called species. But these simple distinctions are not sufficient to satisfy the needs of natural history. We might say, for example, that the violet is one kind of plant and the oak is another, which is true; but there are also different kinds of violets and different kinds of oaks. We might say that the apple is one kind of plant and the pear is another, but there are different kinds of apples, as the crab apple and the common apple, and there are different kinds of crab apples, and of common apples. We must not only arrange the kinds of plants into groups, but we must have groups of different grades. For example, botanists call each distinct kind of plant, as the sugar maple, the white oak and the dandelion, a species. Then the species that rather closely resemble each other are formed into groups, each of which is called a genus (plural, genera), as the sugar maple and the soft maple; the white oak, the red oak and the bur oak; the raspberry and the blackberry; and the apple, pear and quince. Then the genera that resemble each other, as the one containing the apple, pear and quince, and the one containing the plum, cherry and peach, are formed into other groups called families or orders. Thus families are made up of genera, and genera are made up of species. There may be, also, different varieties in the same species, as the different varieties of apple, pea or strawberry.

An extensive retail bookstore furnishes an object lesson in classification, though we must remember that in natural history it is usually the names and descriptions of plants and animals that are classified, and not the plants and animals themselves. In the bookstore, we will observe that the books are not placed upon the shelves without order, but that they are arranged in groups. Different

copies of the same work are placed together. Works on the same subject, as Gray's Botany, Wood's Botany, Bessey's Botany are also placed in a larger group. Then all the scientific books are formed into a still larger group, as are the books of fiction, the books of poetry, the music books and the like. Comparing this arrangement with that employed in natural history, each separate work, as Gray's "Manual of Botany," Thomas' "Fruit Culturist," Bunyan's "Pilgrim's Progress," would correspond to a species, and the different copies of the same work would correspond to individuals. It should not be understood, however, that the several species of plants and animals are always as readily distinguished as are the different works in a bookstore. The books treating of the same general subject, as the different works on geology, botany or arithmetic, might correspond to genera, and the different classes of books, as scientific books, books of fiction, would correspond to families. There would also be copies of the same work in different bindings, which might be said to correspond to varieties.

22. Scientific names are given to plants and animals because the common names by which they are known are so often local. For example, quack-grass, one of our common troublesome weeds, is known by at least seven different common names in this country alone, and yet, in a given locality it is often known by only one name. Its scientific name, however, *Agropyron repens*, is the same in all languages and countries. Scientific names are usually Latin and consist of two words. The first word is the name of the genus to which the plant or animal belongs, and is called the generic name; the second word designates the species, and is called the specific name. For example, *Pyrus malus* is the scientific name of the common apple,

Pyrus being the genus to which the apple belongs, and *malus* designating which species of the genus is meant.

23. Crosses and hybrids.— We have seen that in sexual reproduction, a union of male and female cells is almost always essential (17). When these cells proceed from two individuals of different varieties (21, 436), the offspring is called a cross; when they proceed from individuals of different species, it is called a hybrid. At the present time there is some confusion as to the definition of the terms cross and hybrid. The term hybrid is now frequently understood to mean offspring resulting from a sexual union between individuals of any two unlike plants, whether they are varieties or species. Hybrids are possible only between closely allied species and are often incapable of reproduction, in which case they are said to be sterile. The mule, which is a hybrid between the horse and the ass, is a familiar example of a sterile hybrid. Sterile hybrids are not uncommon in plants. A hybrid that is capable of reproduction is called a fertile hybrid.

Hybrids may resemble both parents about equally or they may resemble one parent more than the other. They sometimes differ materially from either parent. The offspring of fertile hybrids are generally variable in proportion as their parents were different from each other, and this variability may continue indefinitely.

24. The theory of evolution, now generally accepted by naturalists, assumes that the higher plants and animals have been gradually evolved from lower forms. The explanation which seems to account for evolution most satisfactorily is that of individual variation (18), and adaptation through the principle that those individuals possessing peculiarities best fitting them to endure the adverse conditions of environment have survived and

perpetuated their kind, while others have perished. This has been termed the survival of the fittest in the struggle for existence.

25. Parasites. — Both plants and animals are subject to being preyed upon by other, usually smaller, plants and animals, that live upon or within their bodies, consuming the tissues of their bodies or their reserve food. Plants or animals that derive their nourishment from other plants or animals are called parasites or parasitic. The plant or animal from which a parasite derives its nourishment is called a host. Parasites are often microscopic in size. They are generally more or less injurious to their host, and form one of the most common sources of disease (270). Some, however, as the micro-organisms of the roots of clover and other leguminous plants, are beneficial (112).

CHAPTER II

THE SEED, GERMINATION AND THE PLANTLET

THE earliest stages of plant growth occur in the seed, and therefore this is an appropriate place to begin our study. The student should follow through some of these discussions by watching the germination of beans, peas, corn, wheat or other seeds.

26. Seeds absorb water when placed in contact with it. If we fill a bottle with air-dry beans, then pour in all the tepid water the bottle will contain, taking care to shake out the air bubbles, and place the bottle in a warm room, the beans will soon swell until they have pressed each other quite out of shape, and no water will be forced out of the bottle. This shows that the beans have absorbed the water and have swollen in consequence. The quality of absorbing water by contact, at ordinary temperatures, is possessed to a greater or less extent by most seeds, and indeed by nearly all air-dry vegetable material. It is unnecessary that the seeds be covered with water to enable them to absorb it. If in contact with any moist medium, as a damp cloth or damp earth, they will absorb moisture and swell.

27. The rate at which seeds absorb water depends upon the following conditions :

The water content of the medium with which they are in contact. — If we place one lot of beans in water, a second in wet earth and a third in slightly damp earth, we shall find that the first lot will swell most rapidly, the second next and the third slowest. Few seeds will absorb enough water from damp air at ordinary temperatures to swell much.

The points of contact. — If we weigh two lots of 100 beans each, on a delicate balance, and mix each lot with well-crumbled, moist loam in a fruit-jar, packing the loam tightly in one of the jars, and leaving it as loose as possible in the other, close both jars to prevent evaporation, and after twenty-four hours sift the beans out of the loam and weigh the two lots again — we shall find that the beans in the jar containing the compacted loam have increased more in weight than the others. This indicates that the beans in this jar have absorbed water faster than those in the other, because they were in contact with the moist loam at more points.

Temperature. — If we fill two bottles with beans, adding ice water to one, placing it in a refrigerator, and lukewarm water to the other, setting it in a warm room, we shall find that the beans in the latter bottle will swell more rapidly than those in the former. This shows that a warm temperature favors the absorption of water — a fact that is true of all seeds. The same would have been true had we planted the beans in two samples of moist earth, placing these in different temperatures.

The nature of the seed-case. — In the bean, Indian corn, wheat and many other seeds, the seed-case is of such a nature that it absorbs and transmits water readily. In certain seeds, however, as of the honey locust, canna, thornapple and the like, especially if they have been

allowed to become dry, the seed-case does not readily transmit water at growing temperatures. Such seeds may lie for weeks, and even months, in tepid water without swelling, but when the water is heated to a certain degree, they swell promptly, a fact often turned to account by nurserymen (36). We cannot always judge by the appearance of a seed-case whether it will transmit water readily or not.

The term seed-case is here used to designate the outer covering of the seed as the word seed is understood by the seedsman or planter. Every seed, as we buy it in the market, or when ready for planting, has one or more covering layers. In the peanut, for example, what we here call the seed-case is commonly called the shuck; in the cocoanut it is called the shell; in the bean and Indian corn it is more often called the skin. In botany, the outer coverings of seeds are given different names, as pericarp, testa, etc., according to their exact office in the make-up of the plant. To avoid explaining the technicalities of a complex subject, it seems preferable to adopt a term that will include the various words used in botany to designate the outer coverings of seeds.

The nature of the seed content and the salts in the soil also influence the rate of absorption of moisture.

GERMINATION

28. What is germination? — If we place a few viable grains of Indian corn between the moist cloths of a seed-tester (Fig. 6), cover with the glass and place in a warm room, we shall observe, if we examine the corn frequently, that a change, aside from the swelling, will soon take place in at least a part of the grains. A viable seed is one that is

capable of germination. In seeds in this condition, the seed-case will be burst by the pressure of a tiny white shoot from beneath. We say that such grains have sprouted or begun to germinate, *i.e.*, have taken the first visible step toward developing into an independent plant.

We have seen that the mature seed contains protoplasm in a dormant condition (13). At a suitable temperature, the protoplasm, on the absorption of water, resumes its active state, and certain cells begin to increase in size and to divide (15), causing the tiny shoot to burst through the seed-case. Germination is completed when the young plant (plantlet) is sufficiently developed to live without further aid from the seed.

29. Moisture essential to germination. — Air-dry corn or other seeds will not germinate if kept however long in a warm room, whereas viable seeds, that have absorbed water until fully swollen, will usually germinate if exposed to air of a suitable temperature, under conditions that prevent their loss of moisture. This shows that a certain amount of moisture must be absorbed by the seed before germination can take place. Seeds must be nearly or quite saturated with water before they will germinate.

In culture we plant seeds in some moist medium; usually the soil, in order that they may absorb moisture and germinate, and thus develop into new plants.

30. Warmth essential to germination. — Had we placed the seed-tester mentioned in paragraph 28 in a refrigerator in which the temperature never rises above 41° F., instead of in a warm room, the corn grains would not have germinated however long they remained there. This shows that a certain degree of warmth is also necessary to germination. Without this, the protoplasm of the seed cannot resume its active state (13). The lowest (mini-

mum) temperature at which seeds can germinate varies considerably with different species, and so does the temperature at which they germinate quickest (optimum) as also the highest (maximum) temperature at which they can germinate. The following table (compiled from Haberlandt and Sachs) shows approximately the minimum, optimum and maximum temperatures at which seeds of the species named germinate:

	MINIMUM	OPTIMUM	MAXIMUM
Barley	32°-41° F.	77°-88° F.	88°-99° F.
Bean (Scarlet runner)	49	93	115
Buckwheat	32 -41	77 -88	99 -111
Clover (red)	32 -41	88 -99	99 -111
Cucumber	60 -65	88 -99	111 -122
Flax	31 -41	77 -88	88 -99
Hemp	32 -41	99 -111	111 -122
Indian Corn	41 -51	99 -111	111 -122
Alfalfa	32 -41	88 -99	99 -111
Melon	60 -65	88 -99	111 -122
Oat	32 -41	77 -88	88 -99
Pea	32 -41	77 -88	88 -99
Pumpkin	51 -60	99 -111	111 -122
Rye	32 -41	77 -88	88 -99
Sunflower	41 -51	88 -99	99 -111
Wheat	32 -41	77 -88	88 -108

These temperatures refer to the soil or other medium with which the seeds are in contact, and not to the atmosphere.

When moisture is sufficient, the time from planting to sprouting decreases rapidly as we approach the optimum temperature. In an experiment, Indian corn sprouted in one-third of the time at 88° F. that it required to sprout at 61°.

Seeds of tropical plants usually require higher temperatures for germination than those of temperate plants.

31. Free oxygen essential to germination. — If we place in the bottom of each of two saucers (if flower-pot saucers are used, they should first be well soaked in water, so that they will not extract water from the soil) a layer of puddled clay or loam, put 25 viable beans on the soil in each saucer, then fill one saucer with moist sand and the other with puddled clay or loam, pressing the latter down very closely around the beans, cover both saucers

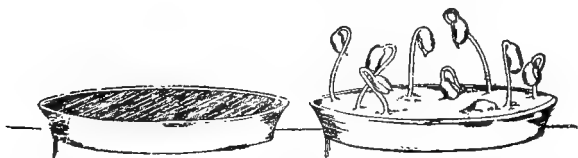

FIG. 4. — Germination in respect to water. In the left-hand saucer beans were planted in puddled soil. In the other, they were covered with sand. They failed to germinate in the puddled soil, because their contact with oxygen was cut off.

with a bell-jar, and place in a warm room for two or three days we shall find that the beans covered with the sand will sprout promptly, while those covered with the puddled soil will not (Fig. 4). (Soil is said to be puddled when packed until it is of the consistency of putty.) In the sand-covered saucer the air between the grains of sand has had access to the beans, while in the other air has been shut out, which explains the sprouting of one lot of seeds and the failure of the other. About one-fifth of the atmosphere is free oxygen, *i.e.*, oxygen that is not chemically combined with any other substance.

We have seen that protoplasm in its active state requires oxygen (13). Unless seeds are so planted that a certain amount of this free oxygen can reach them, they cannot germinate. This probably explains why very deeply planted seeds rarely germinate. Ordinary water

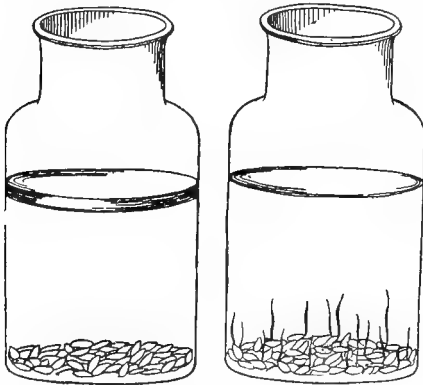

FIG. 5. — Germination and air. Rice grains in water which was previously boiled to expel the oxygen. In the bottle at the left, the water was covered with oil to prevent it from absorbing oxygen again, hence the seeds in it could not germinate. In the bottle at the right, the water was not covered with oil and so it could absorb oxygen, permitting the seeds to germinate.

contains a little free oxygen, but not enough to enable many kinds of seeds to germinate in it, though the seeds of some water plants, as the water lily and rice, will germinate in water. But even these will not germinate in water that has been boiled long enough to expel the oxygen, and is placed under conditions that prevent its absorption again (Fig. 5).

We thus see that seeds require three conditions before they can germinate, viz., a certain amount of moisture, of warmth and of oxygen. In planting seeds, we should consider all these requirements.

32. Prompt germination important. — As a rule, the sooner a seed germinates after it is planted, the better, for it is generally in danger of being destroyed by animals

or fungi, and the plantlet probably loses vigor by too slow development. Weeds may also be gaining a start if germination is delayed. We should, therefore, treat both the seed and the soil in the way that favors prompt germination.

33. Compacting the soil about planted seeds hastens germination by multiplying their points of contact with the moist earth (27). When the soil is becoming drier day by day, as it often is in spring, compacting the soil about planted seeds materially hastens their germination and often secures germination which without the compacting might be indefinitely postponed. The hoe, the feet, a board or the hand or horse roller may be used to compact soil over planted seeds. It is a good plan to loosen the surface of the soil after compacting so as to conserve the soil moisture as much as possible.

34. Warm soil. — Planting should be deferred until the soil becomes warm. Seeds cannot germinate promptly until the temperature of the soil in which they are planted approaches the optimum for their germination (30) during the warmer part of the day, and germination is promoted little, if at all, by planting before this time.

35. Soaking seeds. — Germination may be hastened by soaking seeds before planting. Since seeds cannot germinate until nearly or quite saturated with water (29), and since they absorb water faster from a very wet than from a damp medium (27), and in a warm than in a cool temperature (27), we may hasten germination a little if the soil to receive the seeds is only slightly moist, by soaking the seeds before planting in warm or slightly hot water until they have swollen. This method is sometimes practiced by gardeners with sweet corn and certain other seeds, and its use might possibly be extended with profit.

The water should be heated only to 110° or 120° F. and the soaking may be continued until the seeds have fully swollen.

Soaking is most important with seeds having seed-cases that do not readily transmit water at growing temperatures, as in the honey locust, canna, thornapple or hawthorn, holly, peony and the like (27). Such seeds, particularly if they have been allowed to become dry, are generally soaked in hot water until swollen, before planting, otherwise they might lie in the ground for months and even years before germinating. In treating such seeds with hot water, unless the temperature at which they swell is known, the water should be heated very gradually until the seeds begin to swell, when it should be maintained at that temperature until they are fully swollen. It is said that seeds of the honey locust may be immersed for a time in boiling water without destroying their viability, but such treatment is not to be recommended for any seeds.

36. Cracking seed-case. — Germination is sometimes hastened in seeds of this class by cracking or cutting away part of the seed-case. To favor the absorption of water, nurserymen often drill or file a hole through the seed-cases of date or other seeds having bony seed-cases, or crack dry peach and plum pits in a vise or with an implement resembling a nutcracker (27).

37. Failure to germinate. — Seeds may fail to germinate from a variety of causes, even when exposed to the proper degree of warmth, moisture and oxygen. They may be too old (164), they may not have been sufficiently mature when gathered (162), they may have become too dry (168), they may have been subjected to freezing before sufficiently dry (166), they may have been stored while damp and thus subjected to undue heating, or they may have been damaged by insects or fungi (321) either

before or after maturity. Defects of these kinds are not always visible.

38. Seed testing. — Seeds should therefore be tested before planting to learn whether they will germinate. It is unnecessary to plant seeds in soil to test them, since the seed-tester shown in Fig. 6 is much more convenient. This useful device consists of two circular pieces of clean, moderately thick cloth of rather loose texture, a table plate that is not warped and a pane of glass large enough to

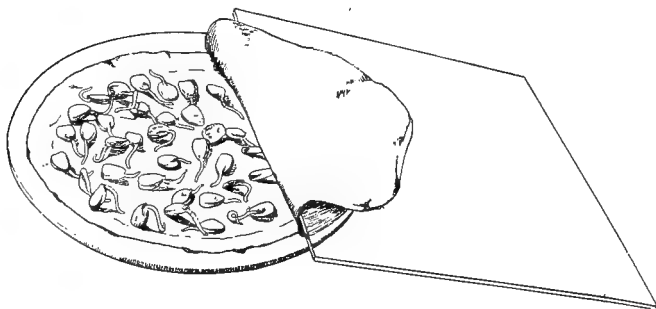

FIG. 6. — A simple seed-tester, adapted to farmers' and gardeners' use.

cover the plate. The cloths are dipped in water, and squeezed a few times while under the water to press out the air. They are then wrung out until moderately wet, and spread over the bottom of the plate as shown, and the seeds to be tested are placed between them. It is well to use a hundred or more seeds of each sample, as a larger number will show the percentage of viability more accurately than a smaller one, and the lot should always be well mixed before taking the sample. The plate should be kept covered with the glass to prevent evaporation from the cloths, and it may be placed in any room of com-

fortable living temperature. The seeds should be frequently examined, and may be removed as they sprout, when by subtracting the number that failed to sprout from the number put in, the per cent of viability may be readily computed. The cloths should be placed in boiling water a few minutes before using them for a second test, to destroy any mold with which they may have become infected.

39. The time required for germination varies greatly in different kinds of seeds. In lettuce seed, the tiny white shoot often breaks through the seed-case within twenty-four hours from planting, while celery seed requires several days to germinate to this extent. The seeds of many plants will not germinate the same season they are formed, even if planted under the most favorable conditions (162).

Individual seeds of the same kind and of the same sample often vary greatly in the time required for germination. Some seeds of red clover will germinate promptly, while others from the same lot under the same conditions will remain "hard" and dormant for months or even years before germinating. Even in seeds that germinate soonest, as lettuce and radish, some individuals will not germinate until several days after the larger number have sprouted. Seeds of tobacco and purslane sometimes continue to germinate through several successive seasons. The reasons for these variations are not known.

THE PLANTLET

By watching the germination of seeds, we may learn some interesting facts. Viable seeds will usually germinate freely on the surface of well-moistened soil or sand, if we

provide a damp atmosphere above them by covering with a bell-jar or otherwise, for light does not hinder germination. One of the interesting facts connected with germination is, that the first shoot, called

40. The hypocotyl grows downward on emerging from the seed-case (27), no matter in what position the seed is placed. It will curve in a semicircle if necessary, to bring its rounded point in contact with the soil. But the hypocotyl is not always able to enter the soil, unless the seed is covered more or less, because the resistance offered by the soil is often greater than the weight of the seed. On this account, as well as to insure a supply of moisture, it is best to cover most seeds at planting, or at least to press them well into the soil (51). In nature, seeds usually become more or less covered, and those not covered generally fail to germinate.

41. The seed-case in germination. — After germination commences, the seed-case is of no further use. It has fulfilled its purpose, which is to protect the seed from the time of its maturity until the conditions arrive for germination, and is henceforth a hindrance to germination in many plants, as it must be torn asunder by the expanding plantlet. If we watch the germination of squash or pumpkin seeds through the different stages, we may discover that nature has made a special provision to help the plantlet in escaping from the seed-case in these plants. As the hypocotyl curves downward, a projection or hook is formed on the side toward the seed, which holds the seed-case down while the seed-leaves are pulled out from it. The action of this hook is shown in the accompanying figures. Sometimes, as shown in C, the point of the seed-case breaks, permitting the hook to slip off, and if the seed happens to be planted edgewise or with the point down-

ward, the hook often fails to catch the seed-case, as in D, and so the plantlet emerges from the soil without freeing itself from the seed-case and is hampered for a time. This provision is peculiar to the pumpkin family, to which the pumpkin, squash, cucumber and melon belong, though

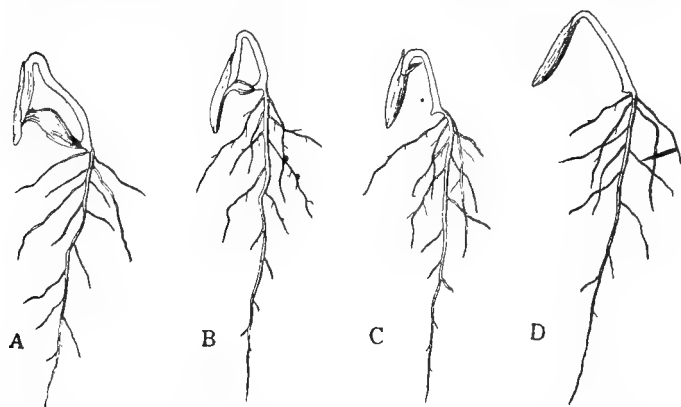

FIG. 7. — Germination in respect to the seed-case. Showing nature's provision to enable the pumpkin plantlet to escape from the seed-case. In B, the hook on the hypocotyl is attached to the lower half of the seed-case. A shows the same after germination is farther advanced. A fully germinated pumpkin plantlet is shown in Fig. 8.

other provisions which accomplish the same end are found in a few other families, but many plants are considerably held back by the seed-case during germination.

42. Seeds of the pumpkin family should be planted flatwise, rather than edgewise or endwise, since in this position they most readily free themselves from the seed-case.

43. Some plantlets need help to burst the seed-cases. — In many seeds having hard and strong seed-cases, as the walnut, butternut and hickory-nut and the pits of the plum, peach and cherry, the enlarging plantlet is often

unable to burst the seed-case, hence germination cannot take place unless assisted by the expanding power of frost, or long exposure to moisture which softens the seed-case, or unless the seed-case is cracked before the seeds are planted (36).

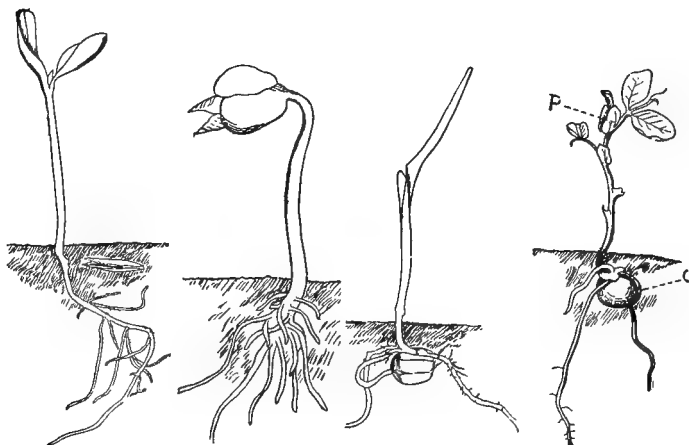

FIG. 8.

FIG. 9.

FIG. 10.

FIG. 11.

FIG. 8. — Plantlet of pumpkin.

FIG. 9. — Plantlet of bean.

FIG. 10. — Plantlet of Indian corn.

FIG. 11. — Plantlet of pea.

In the pumpkin and bean, the seed-leaves (cotyledons) are lifted above the surface of the soil in germination.

In the pea, the cotyledons are not lifted above the surface of the soil in germination.

44. The roots promptly start, as the hypocotyl emerges from the seed-case — the main (primary) root from its point, and the branch (lateral) roots from its side. Sometimes root-hairs (100) may be distinctly seen, especially when seeds germinate in the seed-tester (38).

By studying Figs. 8 to 11, we may learn more of the germinating process.

45. The cotyledons. — In the bean and pumpkin, the seed, or what remains of it, seems to have separated into two parts that are united at one end — the cotyledons or seed-leaves. In the bean and pumpkin, the cotyledons form a pair of clumsy leaves, which in the bean point downward at first, but afterwards become upright, by the straightening hypocotyl beneath them. We observe that the pea has also a pair of cotyledons (*c*), which have not separated to the same extent as those of the bean and pumpkin and are still beneath the soil. The corn, in common with other plants of its class, as sorghum, sugar cane, the reeds, grasses and the like, has but one cotyledon, and that is not easily seen without dissecting the seed. In Fig. 14, which shows a cross-section of the germinating corn grain, the cotyledon appears at *cot*.

The plants having two cotyledons form a very important class of plants known in botany as Dicotyledons; those having but one cotyledon form a class known as Monocotyledons. There is also a class, including the pine, spruce and other conifers, in which there are several cotyledons.

46. Development of hypocotyl. — The hypocotyl develops differently in different species. In the pea (Fig. 11) and some other plants, the cotyledons remain in the soil, while in the bean and pumpkin, they have been lifted bodily into the air. This striking difference is due to the fact that in the pea, the hypocotyl lengthens very little in germination, while in the bean and pumpkin, it lengthens comparatively very much.

47. Shallow planting. — Seeds in which the hypocotyl lengthens in germination must not be deeply planted. When seeds of this class, which includes many plants beside the bean and pumpkin, are planted in soil, the

cotyledons must be forced through the soil above them, an act requiring considerable energy. If such seeds are covered with much soil, the plantlet is often unable to lift its cotyledons to the surface, and hence must perish. Fig. 12 shows two bean plantlets that tore off their cotyledons in the vain attempt to lift them through five inches of soil.

The plantlets of wheat, barley and oats, though much smaller and weaker than that of the bean, readily grow through this depth of soil, because the tiny pointed shoot or plumule (55) of these plants readily insinuates itself between the soil particles and comes to the surface with little expenditure of energy, even when deeply planted. Plantlets of the larger beans usually fail if the seeds are planted three inches deep in a clay soil that bakes above them. Those of the castor bean, though very robust, can hardly lift their cotyledons through one inch of soil, while those of the pea, though much more slender,

readily grow through four to six inches. Apple seeds planted in autumn on clay soil, usually fail to germinate the following spring unless covered with sand or humus, or carefully mulched, because the plantlets are unable to lift their cotyledons through a baked surface soil.

48. **The vigor of the plantlet** is generally in proportion to the size of the seed. This is true not only between

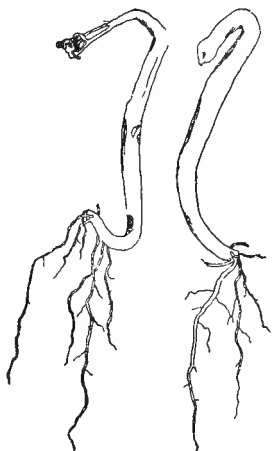

FIG. 12. — Loss of cotyledons. Showing two bean plantlets that tore off their cotyledons from being too deeply planted.

different kinds of seeds, but often between different seeds of the same kind. The larger beans, the horse chestnut and the walnut form much stronger plantlets than clover, timothy and tobacco, and fully developed specimens of any sample of seed usually produce stronger plantlets than the smaller and more shrunken specimens. Growers of lettuce under glass are sometimes able, by sowing only the largest seeds, to raise one more crop during the winter than when the seed is sown without sifting. The practice of sifting seeds before planting, and rejecting the smaller ones, should be more generally followed (Fig. 13). Frequently large seeds contain more food material than the

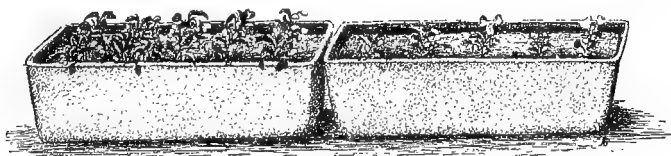

FIG. 13. — Radishes grown from heavy and light seeds.

plantlet needs for best development. Such seeds will not produce more vigorous plants than smaller seeds containing enough food material for the needs of the plantlet.

49. Vigorous seedlings.—The earlier germinations from a sample of seed often form more vigorous seedlings than the later ones. This is one of nature's methods for preserving the vigor of plants. The stronger seedlings overtop the later and feebler ones and crowd them out of existence. We should profit by this hint and reject the later plants in the seed-bed.

50. How deep should seeds be planted?—We have seen that one object of planting seeds in the soil is to place them in contact with moisture (29). Since the plantlet

must force its way through the soil that covers the seed, the less the depth of this soil, other things equal, the less energy and the shorter time are required for the plantlet to reach the surface. Therefore, seeds should not be planted deeper than is necessary to insure the proper supply of moisture.

Small seeds, as of lettuce, celery and carrot, produce such weak plantlets that it is unsafe to cover them sufficiently to insure the proper moisture supply in dry weather. We must, therefore, plant such seeds so early in spring that the soil has not had time to become dry, or if necessarily planted later, we must depend largely upon artificial watering.

51. Surface planting. — Very small seeds, as of petunia and tobacco, should not be covered with soil at all, but may be pressed down into fine loam with a board or otherwise, and must be watered often with a fine-rose watering pot. When small seeds are sown in full exposure to sunlight, it is well to shade the surface with paper or a muslin-covered frame, to check evaporation until the plantlets appear. Small seeds are sometimes covered with a thin layer of sphagnum moss that has been rubbed through a sieve. This helps to retain moisture in the surface soil.

52. Spores. — Spores are the chief reproductive bodies in plants that produce no seeds, as ferns, mushrooms, mosses and the like. They are usually so small as to be barely visible to the unaided eye. The dust that escapes from a puff ball when it is squeezed or from a bunch of corn smut is formed of the spores of these plants. Spores usually consist of a single cell, in which respect they differ materially from seeds, which contain a more or less developed plantlet (53). Ferns are grown from spores sown on the surface of fine soil in a propagating frame (369), in

which the air is kept very moist and the surface of the soil never becomes dry.

53. The embryo. — The plantlet is visible in the seed. If we soak seeds of the four kinds shown in Figs. 8 to 11, or of other kinds, in water until they are fully swollen, and then carefully dissect them, using a magnifying glass when necessary, we may observe that the plantlet is present, compactly folded up in the seed. Germination (28) is

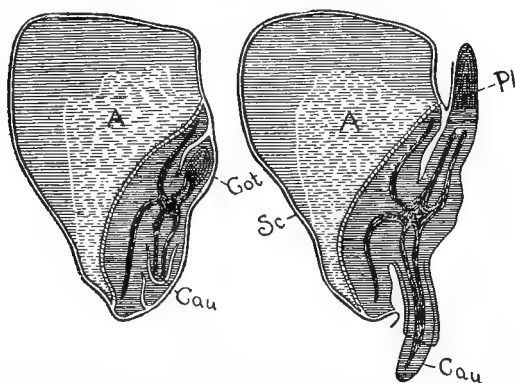

FIG. 14. — Cross-section of germinating Indian corn grain. *A* endosperm; *Cot* cotyledon; *Cau* root; *Pl* plumule. Slightly magnified.

really little more than the unfolding and expansion of this plantlet. The plantlet as it exists in the seed is called the embryo.

54. The endosperm (also called albumen). — From the section of the corn grain shown in Fig. 14, it appears that in this seed, unlike the pea, bean and pumpkin, the plantlet and seed-case do not make up the whole bulk of the seed. The remaining part shown at *A* consists mainly of cells containing starch grains and oil drops, which serve as food for the plantlet during germination, since active protoplasm

cannot exist without nourishment (13). In the pea, bean, pumpkin and other seeds of this class, the food supply, instead of being stored by itself, as in the corn grain, is contained within the plantlet or embryo—mainly in the fleshy cotyledons. When the food supply of the seed is separate from the embryo, as in corn and many other seeds, it is called the endosperm. It is the food supply of seeds that makes them so valuable as food for animals.

55. The plumule. — If we look between the cotyledons of the bean plantlet (Fig. 9), at the point of their union with the root, we may see a pair of tiny leaves, and by carefully separating these if need be, with the point of a pin, we may discover a minute projection — the growing point (66) of the stem between them. These leaves, with the growing point, form the plumule — the terminal bud of the plantlet. These tiny leaves become the first true leaves, and the growing point between them develops into the stem and later leaves. By close examination we may make out the plumule in Figs. 8, 10 and 11. In the pea and corn, it has already made considerable growth.

56. Parts of the seedling. — Thus we see that the plantlet or seedling consists of three parts, viz., the root, the cotyledons (in some plants cotyledon), or seed-leaves, and the plumule or terminal bud.

CHAPTER III

THE GROWING PLANT

HAVING now taken the plantlet out of the seed and having established it as an independent organism, we may next inquire how it secures its food and how it grows.

57. Chlorophyll. — Soon after the plantlet emerges from the seed-case, a green color appears in the parts most exposed to light. This is due to the formation within the cells of chlorophyll — the green coloring matter of plants. Chlorophyll forms only in light, and when a plant containing green leaves is kept for a time in the dark, as when celery is banked up with earth, the chlorophyll disappears and the green parts become white. The chlorophyll saturates definite particles of protoplasm, called chlorophyll bodies, and since the cell-walls and protoplasm are transparent in the younger cells, the chlorophyll bodies give the parts containing them a green color. Fig. 15 shows the distribution of the chlorophyll bodies in the cells of a portion of a leaf of the beech. They appear as minute globules, which in this case are mostly located near the cell-walls. They are most numerous near the upper surface of the leaf — the part most exposed to the sun's rays.

58. Formation of food. — No food can be formed without chlorophyll. By the agency of chlorophyll, the

chlorophyll bodies absorb energy in the form of light. This energy the chlorophyll body uses to take to pieces the carbonic acid, mineral salts and water absorbed from the air and the soil, and to recombine them into foods which can be used by the protoplasm in making new parts and repairing waste (photosynthesis). Until this food manufacture commences, no new plant substance has been formed. It is true that new cell-walls and new protoplasm

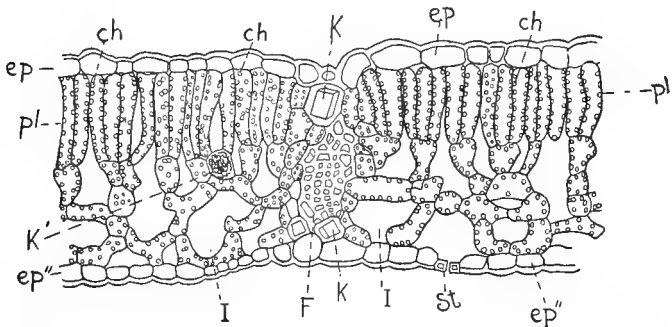

FIG. 15. — Cross-section through leaf of beech (*Fagus*). *Ch* chlorophyll bodies; *Ep* epidermis of upper surface of leaf; *Ep''* epidermis of lower surface; *K* cells containing crystals; *Pl* palisade layer; *F* vascular bundle; *St* breathing pore (stoma); *I* spaces between the cells (intercellular spaces). Highly magnified.

may be formed from the food supply of the seed before chlorophyll appears, but until chlorophyll is formed, and photosynthesis begins, the whole plantlet with whatever remains of the seed, when dried, weighs no more than the seed weighed at the beginning. The food material formed in photosynthesis is starch, or some substance of similar composition (sugar or oil), which, after undergoing chemical changes if need be, to render it soluble, is distributed throughout the plant to be built up into tissues (assimilation) or to be held as reserve food (14).

Food manufacture (photosynthesis) and tissue building (assimilation) are not necessarily simultaneous, but either may proceed independently of the other.

Green plants can manufacture their food from mineral substances. The food of animals must all have been first formed by plants. Green plants differ fundamentally from animals in this respect. These plants, as just explained, can with the help of energy absorbed from sunlight manufacture their food from mineral substances. The food of animals on the other hand must be obtained, directly or indirectly, from green plants.

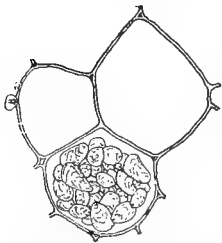

FIG. 16. — Grains of starch stored as reserve food in a cell of potato. Highly magnified.

59. The sources of plant-food. —

By observing plantlets of the bean or pumpkin a few days after germination, we may discover that the cotyledons, which were at first so plump, have shriveled to a mere fraction of their former size. They have shriveled because the food contained by these parts has been absorbed by the developing plantlet. The patrimony furnished by the seed is quickly exhausted. Whence then comes the food that is to complete the development of the plant? Aside from the carbonic acid already mentioned (58), several other substances are required to build up the plant structure. These are almost wholly derived from the soil, through the medium of the water absorbed by the root-hairs (100). They must all be dissolved in the soil water or they cannot enter the plant, for they must pass through the cell-walls, which are not permeable to undissolved solid matter.

60. Elements in plant-food. — The chemical elements regarded as essential in the food of plants are carbon, hydrogen, oxygen, nitrogen, potassium, calcium, magnesium, phosphorus, iron, chlorine and sulfur. Some other elements that do not appear essential are also used by plants. All of these elements, so far as they serve as food, are absorbed by the plant in the condition of chemical compounds, as water, carbonic acid and various nitrates, sulfates and the like.

61. Function of the different elements. — Carbon is the chief constituent of vegetable substances, and forms about half of their total dry weight. Plants obtain their carbon almost wholly from the air, in the form of carbonic acid gas, which is a compound of carbon and oxygen. The leaves absorb and decompose this gas, retaining the carbon and giving off the oxygen (58). Hydrogen and oxygen are obtained by the decomposition of water, which is a compound of hydrogen and oxygen. These enter into the construction of nearly all tissues. Nitrogen is one of the constituents of protoplasm (13). Most plants depend upon soluble nitrates in the soil for their nitrogen supply, but those of the natural order to which the clover belongs, the leguminosae, or the legume family, including the clover, alfalfa, peas, beans and vetch, are able to appropriate nitrogen from the air (260). Phosphorus and sulfur assist in the formation of albuminous substances; potassium assists in assimilation (58); calcium and magnesium, while uniformly present, seem to be only incidentally useful. Iron is essential to the formation of chlorophyll (57). Lime, which is a compound of calcium, appears to be essential to the fruiting of some plants, as the peanut, while detrimental to the fruiting of others, as the cranberry and huckleberry.

Of all the materials obtained by plants from the soil, but three, aside from water, viz., nitrogen, phosphorus and potassium (253) are needed in such quantities that the plants are likely to exhaust the supply, so long as water is not deficient.

62. Water is necessary to growth. — An adequate supply of water is the most important condition for the well-being of plants, since it not only serves in nutrition, but is the vehicle by which all other food constituents are distributed throughout the plant. Comparatively few soils are so poor as to be incapable of producing good crops when sufficiently supplied with water, while the richest soils are unproductive when inadequately supplied with it. Much of the benefit of manuring undoubtedly comes from the increased capacity it gives the soil for holding and transmitting water (92).

The supplying of food material is not the only office performed by water in the plant. The unfolding and expansion of the plantlet is largely due to a strong absorptive power for water possessed by the protoplasm within the cells. This force causes all living parts of plants to be constantly saturated with water. Indeed, it distends the elastic cell-walls with water until they are like minute inflated bladders. The pressure thus set up aids in unfolding the different parts from their snug resting-place within the seed-case and enables the plantlet to stand erect. Growth by cell division, it is true, begins rather early in the germination process, but this cannot take place unless the cells are first distended with water (29). A sufficient amount of water is absolutely necessary, therefore, to growth in plants. Foliage wilts in dry weather because the roots are unable to supply enough water to properly distend the

cells; growth is impossible in plants of which the foliage is wilted. When the water supply is abundant, on the other hand, and the absorptive power of the roots is stimulated by a warm soil (101), the pressure within the cells often becomes sufficient to force water from the edges and tips of leaves. The drops of water that so often sparkle on foliage in the sunlight of summer mornings, commonly mistaken for dew, are frequently excreted from the leaves. In young plants of the caladium, water is sometimes ejected from the leaf-tips with considerable force.

The water of plants is almost wholly absorbed by the root-hairs (100), the leaves having no power to take up water, even in wet weather. The water of plants, with its dissolved constituents, is commonly called sap, except in fruits, when it is usually called juice.

63. Distribution of food materials through the plant.— If we drop a bit of aniline blue into a glass of clear water, it will not retain its form and size, but infinitely small particles will become detached and move about to all parts of the water in which it dissolves. This movement will not stop until the bit has entirely disappeared, and until every part of the water contains exactly as much of the aniline blue as every other part. This equal distribution of the soluble material takes place in response to the law of diffusion, that tends to cause any soluble substance to become equally distributed throughout the liquid in which it is placed. The liquid in the meantime may remain stationary. The process would be the same if we were to put in a very small quantity of each of several soluble substances at the same time. The movements of one of these substances would not interfere much with those of the others.

If we could remove some of the dissolved aniline blue from the water in one part of the glass, it would follow that the dissolved aniline blue would move from the other parts toward this point, and if the removal were continuous, slow currents would move in this direction from all other parts of the glass.

We may now understand how the materials from which the plant is built up are distributed to its different parts. The water absorbed by the root-hairs (100) is not chemically pure, but holds in solution small quantities of various soluble matters contained by the soil, some of which are used by the plant in growth. As these useful matters are removed from the water of the cells, to be formed into food (58), the supply is replenished from the soil, not through any power of selection possessed by the plant, but in accordance with the law of diffusion. In like manner, the food formed by the chlorophyll (58) finds its way to the growing parts. Soluble matters not used by the plant are not taken in to the same extent as those that are needed, because their distribution is less disturbed.

The distribution of soluble matter in the plant is also promoted by transpiration (74).

THE INNER STRUCTURE OF THE PLANT

Thus far, we have considered the plantlet mainly from the outside. Before going farther, it is well to learn also something of its inner structure. We have seen that all parts of the plant are made up of cells (12) and that these cells differ in form and office in the different parts. The cells of the leaf, for example, are different in shape and in the use they serve to the plant, from those of the stem, flower or fruit.

64. The epidermis.—The plant is covered by thin, translucent skin that extends over the entire surface of the leaves, stem and root, called the epidermis (Fig. 17 *Ep.*). This skin is formed of comparatively thick-walled cells and serves to protect the more delicate parts within. It may be readily withdrawn in some plants, as from the leaf of the liveforever (*Sedum telephium*), the cotyledon of echeveria, and young stem of the plum. The exposed surface of the epidermis of the leaves, fruit and young stems of many plants is transformed into a layer that is more or less impervious to water, called the cuticle, which serves to restrict evaporation (74). To protect further the parts, a layer of wax (bloom) is sometimes secreted upon the outside of the cuticle, as in the fruit of many varieties of the plum and grape.

Root-hairs (100) and the hairs and bristles on the stems and leaves of many plants are cells of the epidermis elongated outward. The epidermis must not be confounded with the bark. It is replaced by bark in the older stems of woody perennial plants.

On the upper surface of the leaf, the first two or three tiers of cells beneath the epidermis are usually placed endwise (palisade cells, Figs. 17, 15 and 3). This arrangement favors the entrance and absorption of light. Certain

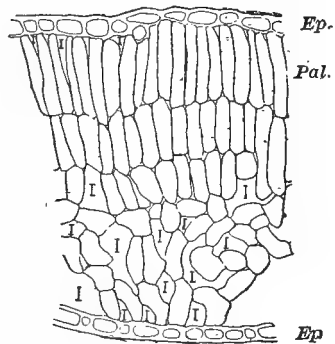

FIG. 17. — Section through the leaf of Oldenburg apple. *Ep.* epidermis; *Pal.* palisade cells; *I* intercellular spaces. Highly magnified. See also Figs. 13 and 20.

of the hardier varieties of apple, as the Oldenburg (Duchess), have more numerous and more crowded palisade cells than less hardy varieties. Compare the palisade cells of a leaf of the Oldenburg apple (Fig. 17) with those of Fig. 3, which shows a section from a leaf of a tender variety of apple.

65. Breathing pores or stomata.—Minute openings commonly occur through the epidermis of leaves and young stems of plants.

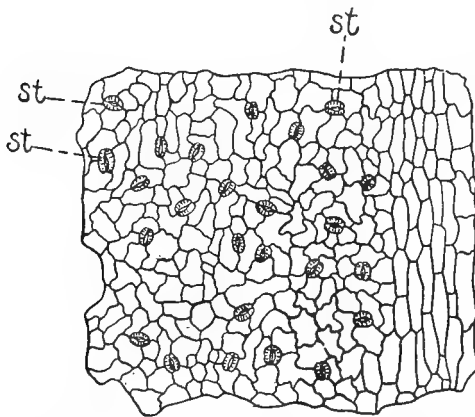

FIG. 18. — Stomata (*st.*) on leaf of the garden beet. Moderately magnified. See also Figs. 15, 19 and 22.

These connect the intercellular spaces (Fig. 17) of the interior of the leaf with the external air and thus serve as breathing-pores. Each such pore is bounded by a pair of cells, guard-cells, capable of so changing as to open or close

the passage. The pore with its guard-cells is called a stoma (plural stomata). Stomata are chiefly found on the lower side of leaves, and are extremely numerous, but are too small to be seen without the microscope. An average apple leaf has been computed to contain about 150,000 stomata to the square inch on its lower surface. The guard-cells are attached together only at their ends and are so thickened on the inner side that they become

more bent or crescent shaped when turgid. Thus the breathing-pore is so opened that it permits the water vapor to escape by diffusion from the interior of the leaf and at the same time permits the carbonic acid gas from the surrounding atmosphere to enter.

These guard-cells are thus delicately balanced valves which are extremely sensitive to external influences. They are open in strong light, but usually closed in darkness and when the leaves are wet. They become turgid as the whole leaf is turgid, thus protecting the tissues from an excess of water. Conversely, as the leaf loses water the guard-cells become less turgid and close, protecting the tissues from too great a loss of water. In this manner the plant regulates the amount of water in its tissues according to its requirements. The

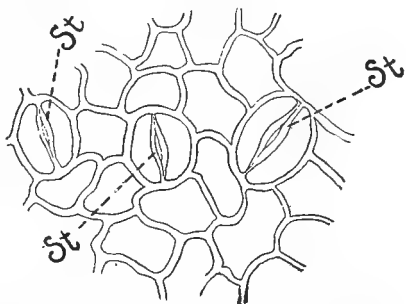

FIG. 19. — Stomata (*st*) on leaf of Oldenburg apple. Highly magnified.

slightly raised spots or dots on the smooth bark of the young shoots of many woody plants (lenticels) are openings which serve a similar purpose to the stomata.

66. The growing point. — At the tip of the stem and just behind the tip of the root, is a group of cells forming the so-called growing point. These cells divide very rapidly during the growing season, and from them all other kinds of tissues are developed.

67. The vascular bundles. — While the plantlet remains within the seed-case, it consists largely of cells

more or less cubical or globular in outline. But germination scarcely commences before some of the cells begin to increase greatly in length without a corresponding increase in thickness. Cells of the former class, *i.e.*, those that retain their globular shape, are called parenchyma, and those of the latter class prosenchyma (Fig. 20). Fig. 17 shows parenchyma cells from the apple leaf.

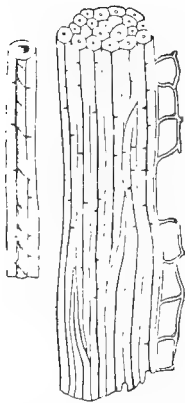

FIG. 20. — Prosenchyma cells from stem of rye. Highly magnified.

The elongated cells form in groups or bundles (vascular bundles, also called fibro-vascular bundles) that extend lengthwise through the stem and roots, and since the individual cells overlap and are in intimate contact, they form threads often visible to the naked eye. By the absorption of the ends of some of the cells, tubes (ducts or vessels) of very considerable length are formed. In other cells of the vascular bundle, the walls are much thickened and strengthened by woody deposits. These vascular bundles serve the double purpose in the plant of strengthening and conducting tissue. The fibers are especially for strength while the vessels

serve chiefly to conduct water and dissolved food material or sap to the different parts. These groups or bundles of fibers and ducts divide and subdivide in the leaves, forming the so-called veins and veinlets. In the roots they divide in a similar manner, extending lengthwise through all the branches and branchlets. Fig. 20 shows a longitudinal section of a vascular bundle of the rye plant and Fig. 21 shows a cross-section of a vascular bundle of the sunflower.

The threads in the stalk of Indian corn and the leaf-stem of the plantain (*Plantago*) furnish examples of well-defined vascular bundles; in most stems the vascular bundles are less clearly defined. In woody stems they are closely crowded, which gives the wood its firm texture. In some woody plants, as the grape and the elder (*Sambucus*) a cylinder extending through the center of the stem is free from vascular bundles, forming the pith. The young stems of asparagus, the ball of the kohlrabi and the roots of the turnip are "stringy" when the cells of their vascular bundles become thickened by the deposit of woody material in them.

68. The cambium layer.

— In most plants having two or more cotyledons (45), a layer of cells in a state of division (15) exists between the bark and the wood, called the cambium or cambium layer (Fig. 22). It is in this layer that growth in diameter of the stem occurs (70). The bark of plants having the cambium layer separates readily from the wood at times when growth is rapid, because the walls of the newly-formed cambium cells are extremely thin and tender. The slimy surface of growing wood, whence the bark has just been removed, is due to the protoplasm from the

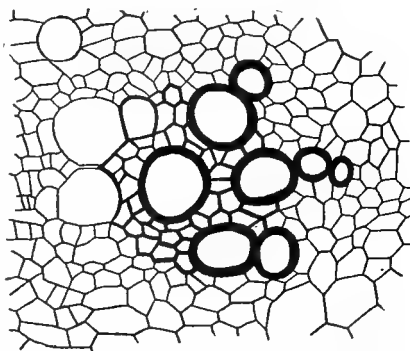

FIG. 21. — Showing cross-section of a vascular bundle of the sunflower, *Helianthus annuus*. Highly magnified. See also Fig. 22.

ruptured cambium cells. In plants having more than one cotyledon, the cambium line is usually readily discerned in cross-sections of the stem — though it is rather more distinct and the bark is more readily separable in woody than in herbaceous stems. In the latter, the

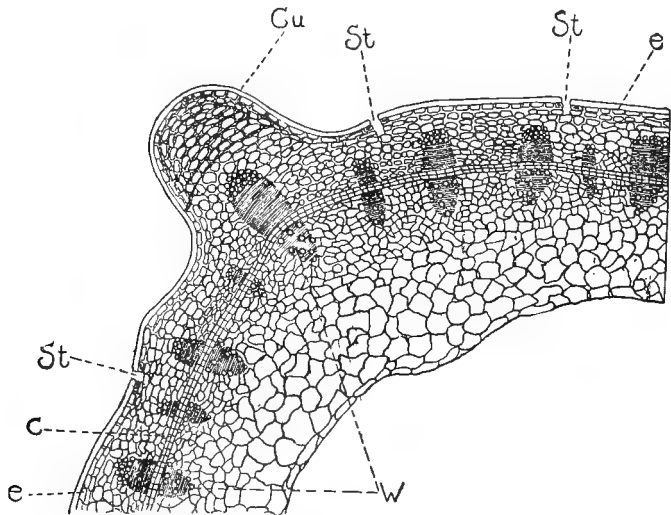

FIG. 22. — Transverse section of corner of a bean stem (*Vicia Faba*). *C* cambium layer; *e* epidermis; *Cu* cuticle; *St* stoma. The dark, oval-shaped spots extending both sides of the cambium layer are the vascular bundles; *W* wood cells of the vascular bundles. Moderately magnified.

part within the cambium line corresponds to the wood of woody stems, and that outside of it corresponds to the bark. Herbaceous stems are those that do not have the hard, firm texture of wood, as the potato, rhubarb and the like.

69. Uniting of the cambium. — Portions of cambium from different plants may unite by growth. If a section

of cambium from one part of a plant is closely applied to the cambium of another part of the same plant, or of another closely related plant, the two portions of cambium may unite by growth, a fact of great importance in horticulture since it renders grafting possible (383). Plants having no cambium layer (70) cannot, as a rule, be grafted, because their stems have no layer of dividing cells — the only cells that unite by growth.

70. How stems increase in diameter. — There is no cambium layer in plants having but one cotyledon (45), of which Indian corn, the grasses and palms are examples. In such plants there is no clear separation between bark and wood; the stem enlarges for a time by growth throughout its whole diameter, after which it ceases to expand.

In plants having two or more cotyledons, however, additions to the bark cells are constantly being made during the growing season on the outside of the cambium layer, as are additions to the wood cells on the inside of it (Fig. 22). It follows that growth of the bark takes place on its inner surface and growth of the wood takes place on its outer surface. This explains the vertically-furrowed appearance of the bark of old trees which is being constantly split during the growing season by the forming layer within. It also explains the ringed appearance of a cross-section of a woody stem. A new ring of wood is formed each season on the outside of that previously formed, and the line separating the rings marks the point where growth in autumn ceased and was renewed the following spring. The age of a given part of the stem of a woody plant is approximately indicated by the number of its wood rings. More than one wood ring is sometimes formed in a season. If growth ceases during the summer from severe drought or other

cause, and is renewed the same season, an extra ring is formed.



FIG. 23 — Live poplar tree with hollow trunk, showing to what extent the heartwood may decay without destroying the life of a tree.

71. The living part of woody stems in plants having more than one cotyledon, *e.g.*, apple or maple (45), is usually limited to a rather thin layer of bark and wood, of which the cambium (68) forms the center. The cells of the so-called heartwood and those of the dry and furrowed outer bark have lost their protoplasm, and hence are no longer alive, though they serve a useful purpose in adding strength and protection to the vital layer. The heartwood of a tree may largely decay without materially interfering with the vital processes (Fig. 23).

72. The healing of wounds. — Cambium cells exposed to the air by partial or complete removal of the bark soon perish, as a rule, hence growth ceases in a part of the stem thus injured. The uninjured cambium cells on the borders of

the wound may, however, by division (15), form a cushion of new material (callus) that gradually extends over the

injured part. A new cambium layer may thus be formed over the wound if it be not too large, so that growth of the stem may be resumed at this place. The same process occurs when a branch is cut off near its union with the stem. If the wound is not too large, callus healing follows soon by new growth from the uninjured cambium and other adjacent cells (Fig. 24). The younger the uninjured tissues are, the more rapid is the healing. In planted cuttings, the uninjured cambium cells at the base form the callus by continued division (Fig. 25).

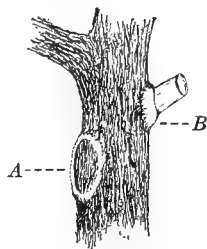

FIG. 24. — Healing of wound formed by cutting off a branch (A).



FIG. 25. — The callus at base of willow cutting.

Exposure of the bark to undue heat or cold may destroy the living tissues including the cambium, causing sunscald (185).

In periods of very rapid growth, when the cambium cells are unusually active, large areas of bark, even extending clear around the stem and as deep as the cambium layer, may sometimes be removed from trees without destroying their life, provided the recently-formed wood layer is not injured (70). In this case, the outer cells of the thin layer of cambium that remains on the surface of the wood promptly change to bark cells, hence a new bark layer forms over the exposed surface the same season.

Several successive crops of bark are sometimes removed from the trunk of the cork oak (*Quercus Suber*), but in this case the cambium layer is usually not injured.

THE WATER OF PLANTS AND ITS MOVEMENTS

73. Water-content of plants. — Plants contain large amounts of water. We have seen that the cell-walls of living plants are constantly saturated with water (62), and that the cells of the growing parts are always more or less distended with it. The proportion of water contained in living plants is generally very large. In the root of the turnip and in some fruits, it may exceed ninety per cent of the whole weight. It is greatest in young plants and in the younger and growing parts of older plants. The proportion of water is not constant in the same plants, but varies somewhat with the water content of the soil and with meteorological conditions.

74. Transpiration. — The water of plants passes off more or less rapidly from parts exposed to the air — usually as an invisible vapor. This invisible escape of water from plants is called transpiration. It is due mainly to evaporation of the water from the surface of the interior cells of the plant and its diffusion as water vapor through the stomata (65). The fact that the stomata control the rate of escape of this water vapor from the interior of the leaf explains why fluctuations occur in the amount of transpiration from living plants that do not occur in the evaporation from dead organic material under similar conditions. For example, transpiration is more rapid in light than in darkness, because the stomata (65) are open in the light and thus facilitate the escape of water from the intercellular spaces. Plants poorly supplied with nourishment transpire more freely under the same conditions than those well supplied. The amount of transpiration varies greatly in different plants and depends upon the leaf surface, the nature of the epidermis and

cuticle (64), the number of stomata (65), and so on. Some plants, as purslane, the sedums and cacti, have special water-storing tissues, from which transpiration is extremely slow.

Experiments indicate that the transpiration from most leaves is between one-third and one-sixth as much as the evaporation from an equal area of water. When we take into account the immense leaf surface of a large tree, it is evident that the aggregate transpiration must be very great, as is often illustrated by the dwarfing in-



FIG. 26. — Competition: showing how a spruce hedge dwarfs an adjacent crop in dry weather.

fluence of trees upon adjacent crops in dry weather (Fig. 26). Transpiration is much more rapid during dry than during wet weather, and in the rare atmosphere of high altitudes than in the denser atmosphere of low lands.

Excessive transpiration, as occurs in very dry weather, is detrimental to plants, since it reduces the water pressure within the cells below the point where healthful growth can take place (62); but normal transpiration *i.e.*, not sufficient in amount to interfere with healthful growth, is doubtless beneficial, since it aids in carrying

food materials from the soil into the leaves (58). For this reason plants native to regions having a rather dry atmosphere do not thrive in greenhouses unless abundant ventilation is given to encourage transpiration.

75. Influence of trees.—Trees are detrimental to crops in their vicinity not only by the shade they cause, but also by their exhausting effect upon the soil moisture in dry weather. The area affected by a group of trees is often much larger than is supposed. Fig. 26 shows how an evergreen hedge may restrict the growth of corn in an adjoining field. We should not infer from this, however, that trees are on the whole detrimental to agriculture. They serve many useful purposes.

Experimental crops intended to be comparable with each other should not be planted near growing trees.

76. The brittleness of young plant tissues depends upon the degree of water pressure within the cells. Foliage is usually most brittle during the morning and least brittle during the latter part of the day, because transpiration is most active during the warm hours of the day. Lettuce and other salad plants are, therefore, apt to be more crisp and tender when cut in the morning. Tobacco, in which breaking of the leaves is harmful, is preferably cut in the afternoon. Young hoed crops are generally less injured by the smoothing harrow in the afternoon than in the morning, and grass intended for hay usually dries soonest when cut in the afternoon. Lawn grass generally cuts easier in the morning than in the afternoon. Slightly withered vegetables may have their crispness partially restored by soaking them in water for a time.

77. The transpiration current.—Since the water of plants is taken in from the soil through the root-hairs

(100), and escapes more or less rapidly by transpiration (74), it is clear that in leafy plants a current of water, the transpiration current, must pass from the roots through the stem and branches into the leaves, and that the rate of this current will depend much upon the rate of transpiration from the foliage. When the soil moisture is reduced and transpiration is excessive, this upward current of water is not always sufficient to maintain the normal pressure within the cells (62), hence the foliage wilts, or the leaves roll up, as in Indian corn and some other plants of the grass family. This current passes chiefly through the younger vascular bundles (67), which in trees constitute the so-called sap-wood, since the cells of these are less obstructed by woody deposits than those of other tissues.

The physical forces that cause the soil water to rise to the tops of the tallest trees are not fully understood. Apparently, the pull resulting from the transpiration of water is the chief thing. This is supplemented apparently by the process known as osmosis, which is the tendency that causes two liquids of different densities to mix with each other when separated by a permeable membrane. The less dense liquid tends to flow into a denser one with a force corresponding to the difference in their densities. Cell contents are denser than soil water, hence the latter tends to flow into the cells, and thus to rise in the plant.

78. The flow of sap in spring.— In the temperate zones, evaporation from the leafless stems of deciduous trees and shrubs nearly ceases during winter. The portion of the roots of these plants, however, that lies below the frost line continues to absorb water, which gradually accumulates in the stems and branches. Ordinarily this water is absorbed and held within the cells so that if

one cuts into such a tree trunk no sap appears. Under certain conditions in early spring, however, the sap "flows" freely and this creates so much pressure in some trees and shrubs that water drips from wounds in the wood, bearing with it, of course, the materials it holds in solution. This happens when we tap a sugar maple tree in spring. Alternate rise and fall of temperature above and below 32° F. are necessary to start the flow of sap in the maple, hence this occurs only for a few days in early spring. With the birch and some other trees and the grape vine, the strongest sap-flow or bleeding comes a little later in the spring. This spring sap pressure or flow seems to be for the purpose of forcing the water into the stems of the plants in sufficient quantity to supply the unusual need which comes with the opening buds and rapidly expanding leaves, because with each contraction new supplies of water or air are drawn into the stem, and thus the pressure is maintained. Sap ceases to flow on the opening of the buds, because transpiration from the foliage (74) quickly relieves the abnormal pressure.

The popular idea that the flow of sap in spring is due to a rapid rise of water through the stem at that season is erroneous. The sap is really rising through the stem much faster in midsummer than in early spring.

79. The current of prepared food (elaborated sap). — The food of the protoplasm in the different parts of the plant is prepared almost wholly in the leaves (120). We know, however, that growth occurs in the stem and roots as well as in the leaves. It is clear, therefore, that when the stem and roots are growing, a movement of food matter must occur from the leaves into these organs. This movement may be demonstrated by a simple experiment. If a notch deep enough to pass

through the bark and a little into the wood is cut in the stem of any of our common woody plants during spring or summer, a callus or cushion of new cells (72) will soon form on the upper side of the notch, but not on the lower, showing that the material from which new cells are formed is passing downward. Close examination will show that this callus forms just outside the union of the bark and wood. In all plants having more than one cotyledon (45), this current is through the sieve tubes in the inner layers of the bark. The prepared food matter dissolved in water passes readily through the cell-walls, and passes from the leaves to other parts of the plant by diffusion (63).

80. Killing trees by girdling. — To destroy the life of a tree that cannot be conveniently removed, we girdle it by cutting a notch about the trunk beneath the lowest branch. This cuts off the downward food current and so starves the protoplasm of the roots. If the notch is made after the leaves have expanded in spring, and extends only through the bark, the leaves may remain fresh for several weeks, for the transpiration current passing through the sap-wood (77) may continue. Since the roots receive no nourishment, however, they will soon cease to grow and will usually die from starvation before the following spring. If the notch is cut deep enough to reach through the sap-wood, thus cutting off both the ascending and descending currents, death of the tree follows soon.

81. Root starvation may occur without girdling. In seasons of extreme drought, when the leaves are poorly supplied with crude food materials from the soil, the amount of prepared food may be so meager that the food current will be exhausted before it reaches the roots.

In such cases the roots perish, and the tree is found dead the following spring. This most frequently occurs with trees on poor soil, that have suffered from insect attacks as well as from a dearth of water. It often occurs also in recently-transplanted trees that fail to make satisfactory growth the first season.

82. Weed destruction. — To destroy the most persistent weeds we starve the roots by preventing all leaf growth (339).

83. Restriction of the descending food current promotes fruitfulness by causing an accumulation of prepared food in the stem and branches (134). This is a weakening process, however, and should not be extensively practiced under cultural conditions.

84. The storage of reserve food. — In healthy plants food is usually prepared faster than it is consumed by growth. The surplus may be in the form of starch, as in the potato (Fig. 16), wheat and sago; sugar, as in the sugar cane, sugar maple and beet; or oil, as in cotton seed, flax seed and rape. Aside from the seeds, which are always stocked with reserve food, certain plants living more than one year, as the potato, beet, onion, kohlrabi, and the like, have special accumulations of food in certain parts, and the parts of plants that contain such reserve food are most valuable as food for man or animals. The proportion of starch stored in potato tubers is not constant, hence the food value of different samples of potatoes may vary greatly. In woody plants the surplus food is more evenly distributed through the different parts, though the older leaf-bearing wood is usually best supplied.

85. Use of reserve food. — Plants use their reserve food in the production of flowers and seeds (134), and in

repairing damages, as the healing of wounds (72), or the replacement of leaves destroyed by insects or otherwise. Annual plants (337) expend all their reserve food in flower and seed production and then perish as soon as the seed is ripe. Biennial plants devote the first season of their life to storing an abundant food supply, which is expended in flower and seed production the second year. Our seed crops, as oats, corn, peas and beans, are mostly annuals; our vegetables other than seeds, as beets, cabbage, parsnips and celery, are mostly biennials. Perennial plants, in normal condition, expend only a part of their reserve food in any one season for the production of flowers and seeds, withholding the remainder for nourishment through the winter and to develop leaves the following spring. The reserve food in dormant cuttings (358) enables them to form roots and expand their buds.

CHAPTER IV

THE ROOT AND THE SOIL

WITH the out-door cultivator, the part of the plant environment that lies beneath the soil surface is more under control than the part that lies above it. He can do little to change the composition or temperature of the air or the amount of sunlight; he may do much to influence the fertility, the texture, the drainage and the aëration of the soil. A knowledge of the roots of plants and of the soil in which they grow and feed, is, therefore, of the utmost practical importance.

86. Functions of the root. — The roots of land plants serve to anchor the plant in the soil, enabling the stem or stems of erect species to grow upright, and to supply the plant with water with its dissolved food materials (62).

87. Origin of the root. — The root originates in the stem. As we have seen, the primary root develops from the lower or “root-end” of the hypocotyl (44). But lateral roots may develop freely from other parts of the stem. If we examine the base of the stem of a plant of Indian corn a few weeks after planting, we may see that the main roots start above the point at which the stem was originally attached to the seed; and if we pull up a pumpkin vine or an untrellised tomato plant late in summer, we often find it rooted from the stem at some dis-

tance from the original root. Lateral roots originate in the internal tissues of the stem or root and not close to the surface, as do buds (131).

88. Moisture excites root growth. Roots develop, as a rule, from parts of the stem that are maintained for a certain time in contact with abundant moisture. In the pumpkin vine and tomato plant above mentioned, nearness to the soil furnishes a moist atmosphere. A corn stalk pegged down to the ground for some distance will usually root at all joints of the stem in contact with the soil. A potato plant grown under a bell-jar, where the air is nearly saturated with water, will form roots at any joint of the stem. In parts of the tropics where the air is very moist, certain plants, as orchids and the Banyan tree (*Ficus indica*), emit roots freely from the stem above ground. Cuttings (358) and layers (349) form roots because they are maintained in contact with abundant moisture and at a suitable temperature. Cuttings of some plants, as the willow and nasturtium, root promptly when their stems are immersed in water.

89. Oxygen is necessary to the life of roots. Since the cells of newly-formed roots are filled with protoplasm, they must have access to the oxygen of the air, or they can neither live nor grow. This is shown by a simple experiment. Boil a quantity of water fifteen minutes or longer, to exhaust it of free oxygen, and then cool it quickly by setting the dish containing it in cold water. Now place a healthy cutting (358) of some plant that roots freely in water, as willow, nasturtium or wandering jew (*Tradescantia*), in each of two tumblers. Pour a part of the cool, boiled water into one of the tumblers and add a little olive oil to form a film over the liquid, thus preventing it from absorbing more air. Then

agitate the rest of the water vigorously to impregnate it again with oxygen, and pour some of this into the second tumbler. Set both tumblers in a light, warm place. In a few days roots will start freely from the slip in the tumbler in which the water has access to the air, but not



FIG. 27.—Slips of tradescantia in water containing oxygen (right glass) and in water containing no oxygen (left glass). From nature.

in the other (Fig. 27). If now the rooted cutting is placed in oil-covered water that has been exhausted of its oxygen by boiling, the roots will soon die.

The copious formation of root-hairs (100) that reach out into the moist atmosphere of the seed-tester (38), and that so often fills the soil cavities with a delicate, cottony down, is further proof that roots search for air as well as water. The total absence of live rootlets in the puddled clods of badly-

tilled fields shows that roots will not penetrate soil from which the air has been expelled by undue compression while wet. Plants in overwatered greenhouse pots sometimes send rootlets into the air above the soil to secure the oxygen from which their roots have been deprived.

90. The ideal soil for land plants must contain enough plant-food and water fully to supply the plants, and yet be so porous that air can circulate through it and come in contact with the roots. (Each particle of such a soil is surrounded by a thin film of water, while between the particles are spaces connected with each other, and filled with moist air that is in communication with the air above the soil. The root-hairs (100) apply themselves intimately to the wet surfaces of the soil particles, or reach out into cavities filled with saturated air, and are thus able to draw in the well-aërated soil water, with its dissolved food constituents, in sufficient quantity to restore the loss from transpiration (74) and to distend the newly formed cells (62).)

91. Changes in the soil. — The soil is a scene of constant changes. The part of the soil in which the roots of plants grow is the field of most potent vital and chemical activities. The dead remains of plants and animals it chances to contain are undergoing decomposition during the warm season, by serving as the feeding ground of myriads of microscopic plants — bacteria (255). Through their agency nitric acid, which supplies the higher plants with their most valuable food element — nitrogen (254), is formed in the soil. The carbonic acid which the plants take from the air during growth is set free and helps slowly to disintegrate the mineral soil constituents, rendering these soluble and thus available as plant-food. In winter, the frost separates the compacted particles of clods, making the latter permeable to air and rootlets, or flakes off new fragments of rock, thus unlocking new supplies of mineral fertility.

92. The importance of organic matter in the soil. — Crops secure a large part of their nitrogen, as well as

of other food substances, from dead organic matter, *i.e.*, animal or vegetable materials. The application of such matter to the soil is, therefore, of great importance, where large crops are expected. Stable and barn-yard manure, the offal from slaughter-houses, tanneries, breweries, and so on, are all valuable for this purpose, when wisely used. Stable manure is further beneficial by absorbing moisture, oxygen, ammonia and carbonic acid from the air as well as much solar heat. Not only does organic matter in the soil furnish plant-food, but while in a partially decomposed state, it renders the soil porous and greatly increases its water-holding power.

93. Soil ventilation. — (The soil needs ventilation. The roots of growing plants and the decomposition of organic matter in the soil tend constantly to exhaust the latter of its free oxygen, and to replace this with carbonic acid, which is not used by the roots. Hence, without some interchange between the contents of the soil cavities and the atmosphere above, the roots sooner or later become smothered and perish.) In sufficiently porous soil, changes in temperature and in atmospheric pressure, aided by wind and rain, furnish the needed soil ventilation, but in poorly-drained soils, and soils not thoroughly tilled, the roots of plants often suffer from insufficient oxygen. A puddled crust on the surface of clayey soil, due to the compacting influence of rain, is a great hindrance to its ventilation. Earthworms and other animals that burrow in the soil aid in aërating it.

94. Ventilation of hotbeds. — Hotbeds require especial care in ventilation (365), since they usually contain large quantities of decomposing organic matter (manure), which rapidly absorbs oxygen from the soil, replacing it with carbonic acid.

95. Soil aëration. — Drainage promotes soil aëration by forming an outlet for the surplus water that would otherwise fill the cavities. Although moisture is essential to root growth, land plants do not prosper with their roots immersed in water. True, most plants may be grown in “water culture,” if their roots are kept in water that is freely exposed to air from the time the seed germinates, but the roots of plants growing in soil soon smother for want of free oxygen when the soil cavities are filled with water, because the soil tends to prevent the water within its cavities from absorbing air.

96. Potted plants require drainage (412), and the outside of the pots should be kept clean, to admit air through their walls. Potting soil should contain sufficient sand and humus (92), so that it does not readily become puddled by watering (31).

97. Watering potted plants. — Potted plants should be watered with care (218). They should receive sufficient water so that the soil particles are constantly surrounded with a film of water, but not so much that the soil cavities remain filled.

98. How the root-tip penetrates the soil. — Darwin made the interesting discovery that the root-tip, in advancing through the soil, does not move in a straight line, but has an oscillating motion, which enables it to take advantage of openings between the soil particles. The force with which the root-tip is pushed forward was calculated by Darwin to be at least a quarter of a pound in some cases, while the increase of the root in diameter may exert a much greater force. The root-tip is protected in its passage through the soil by a thimble-like covering called the root-cap. The root-cap is readily seen without a magnifying glass when a bean plant is grown in water.

99. **Growth of roots in length.** — Since the soil offers more or less resistance to the growth of roots, it is evident that the roots of land plants cannot elongate through their whole length at once. On the contrary, the part that increases in length is limited to a short portion just behind the root-tip. Sachs found that the part of the rootlet of the broad bean that increased in length by growth scarcely exceeded half an inch long. In Fig. 28 the parts that are increasing in length are considerably shorter than the root-tips (*RT*).

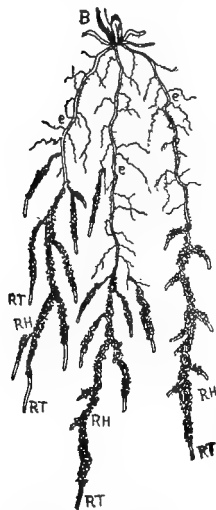

FIG. 28. — Roots of young wheat plant. The parts inclosed in sand (*RH*) are surrounded by root-hairs. *RT*, root-tips; *e*, older parts of root. One-fourth natural size.

100. **The root-hairs** (Fig. 29 *B*) develop just behind the elongating part of the rootlet and are present in nearly all plants. Their object is to absorb water, with the food materials it contains. The root-hairs greatly increase the absorbing surface of the roots, just as leaves increase the absorbing surface of the plant above ground. Each root-hair consists of a single elongated cell (Fig. 30), and is filled with protoplasm, as are the cells in other living parts of the plant (13). As the extremity of the root advances through the soil

by growth, new root-hairs are formed in front of the older ones, while those farthest back as rapidly die off, so that only a short portion of a rootlet bears root-hairs at any one time. In Fig. 27 root-hairs are visible in the right glass, and in Fig. 6 they may be seen

on the hypocotyl of some of the germinating corn grains. In Fig. 29 *A* and in Fig. 28 the parts of the root bearing root-hairs are indicated by the sand which adheres to these parts. It is usually difficult to see the root-hairs of plants growing in the natural soil, but they may sometimes be discovered with the help of a pocket magnifying glass by carefully removing the soil particles about the younger roots, when the silky network of root-hairs may be seen filling the smaller pores of the soil or enveloping the soil particles. Fig. 30 shows a magnified root-hair of the wheat plant, closely attached to some particles of soil. The root-hairs are able to take up water freely, even from soil that does not appear very wet, because each soil particle is enveloped in a thin layer of water (90). Still more interesting is the fact, that root-hairs are able to dissolve mineral matters in the soil, by their excretions, most important of which is carbonic acid, thus permitting the plant to use these matters as food.

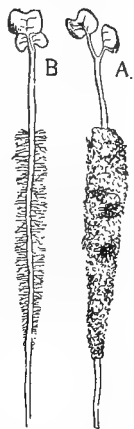

FIG. 29.—Seedlings of turnip showing root-hairs.



FIG. 30.—Tip of a magnified root-hair with adhering particles of soil.

101. Absorption of water.—Root-hairs absorb water with considerable force. It is the absorptive power of the root-hairs that causes water (sap) to flow so freely

from injured stems of grape vines and some other plants in spring (78), and from wounds in the trunks of some trees in summer. Hales found the absorbing force of the roots of a grape vine equal to the weight of a column of mercury $32\frac{1}{2}$ inches high. This force is probably due to the absorptive power of the protoplasm in the very active young root cells. It is affected by the temperature of the soil within certain limits, lessening as the temperature falls, and increasing as it rises. Sachs found that the foliage of plants of tobacco and pumpkin drooped when the temperature of the soil in which they were growing was reduced much below 55°F. , showing that the roots did not absorb enough water at that temperature to compensate for the loss by transpiration (74). When the soil is warm, on the other hand, the absorptive power of roots may be sufficient to force water from the tips of leaves during cool nights when transpiration is slight (62).

102. Parts that absorb. — Only the youngest parts of roots are active in absorption. The part from which the root-hairs have perished absorbs little water, but is chiefly useful in giving strength to the plant and in conducting the plant fluids. The absorbing part of any given rootlet is, therefore, comparatively short. It follows that the amount of nourishment a given plant can receive will depend upon the number of its root-tips. Our treatment of the plant should, therefore, be aimed at promoting the formation of root-tips. In other words, we should encourage root branching. Root branches must not be confounded with root-hairs. In Fig. 28, branches of the roots appear at *e, e, e*. The branches bear root-hairs when of sufficient length, but root-hairs never develop into branches.

103. The branching of roots in land plants appears to depend much upon the amount of free oxygen (31) and available plant-food which the soil contains, so long as the moisture supply is sufficient. In cultivated ground having a compact sub-soil the roots of annual crops usually branch most freely just at the bottom of, or a little below, the layer of soil stirred by the plow, this being the point at which the supply of oxygen, plant-food and moisture is probably best suited to root growth. As the depth of tillage is increased, roots branch freely at a greater depth. Masses of decomposed manure beneath the surface of the soil are usually penetrated through and through with finely-branched roots; and fragments of bone in the soil are often inclosed in a mat of delicate rootlets. These materials furnish plant-food in abundance. Roots that penetrate the deeper and more compact layers of soil, on the other hand, and those in poor and dry soils, are usually little branched.

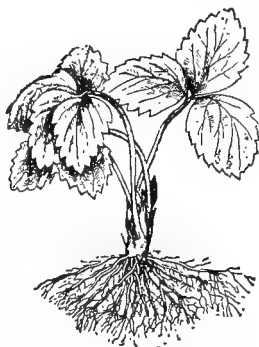

FIG. 31. — Pruning: showing how root pruning stimulates root branching.

It is clear, therefore, that unless a soil is well aërated (93) by a proper system of tillage, and by draining if need be, and unless it contains abundant soluble plant-food in the aërated part, the roots of plants growing upon it will not branch freely and hence the plants cannot be well nourished.

104. **Transplanting** (400) and **root pruning** (416) stimulate root branching. Removing the growing points of either the stem or root (65) stimulates the develop-

ment of other growing points farther back. Transplanting or root pruning accomplishes this in the case of roots (Fig. 31). While these operations may not often increase the total number of root-tips, and hence may not enable the plant to take up a greater amount of nourishment, they do cause the development of a more compact root system, which is of great advantage to young plants grown in the seed-bed or nursery for subsequent transplanting.

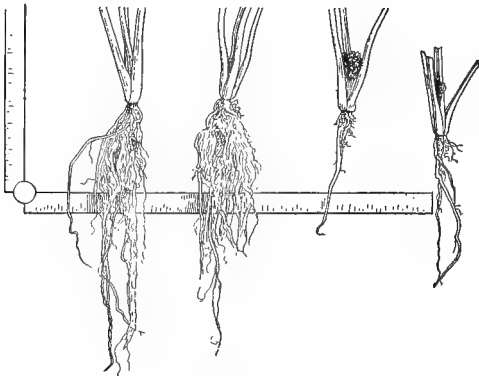

FIG. 32. — The effects of transplanting on root growth of celery plants. The left two plants were transplanted when quite small; the right two were not.

105. Pricking off young seedlings, *i.e.*, transplanting them from the soil in which they grew to other soil, where they have more room, is an important preparation for their final transplanting. They should receive as good care after pricking off as before, with which they soon develop many new rootlets near the base of the stem, that need be little injured in the later removal (Fig. 32).

106. Nursery trees are benefited by transplanting

them once or twice before the final planting out, for the reasons named above.

107. Root pruning (416) is sometimes employed as a substitute for transplanting, and is especially useful to trees that form few branch roots, as the hickory and walnut. In this case, the tap root is cut off a few inches below the surface of the soil the year before transplanting.

108. The horizontal extent of roots is usually greater than is generally supposed. In upright-growing plants, the area occupied by the roots, as a rule, exceeds that covered by the foliage, while in spreading and trailing plants, the roots are probably not often less in extent than the branches. It appears from the observations recorded that even in such plants as the melon and squash, the horizontal extent of the roots usually equals or exceeds that of the runners. As the diffusion of soluble matters in the soil water is probably much hindered by the soil particles, the roots of plants need to travel farther after food than do the branches, which develop in a freely circulating medium. Especially is this true of plants growing in poor soil.

109. Depth of roots in the soil. — It appears from the observations recorded that the extreme depth reached by roots is generally less than their greatest horizontal extent. The distance reached by the deeper roots is probably governed largely by the nature of the sub-soil and the depth of free ground water. But in most annual crops a comparatively small part of the root system develops below the plow line. At the Geneva Experiment Station ¹ the chief root-feeding ground of the field and garden crops grown in that locality appeared to be from three to

¹ See Report of New York Agricultural Experiment Station, Geneva, 1886, p. 165.

ten inches below the surface, while that of crops making large development of stem and foliage during summer, as Indian corn, sorghum, tobacco and the Cucurbitae, appeared to be shallower than in slower-growing crops.

A part of the roots of many crops grow very near the surface of the ground. Branches from the main horizontal roots

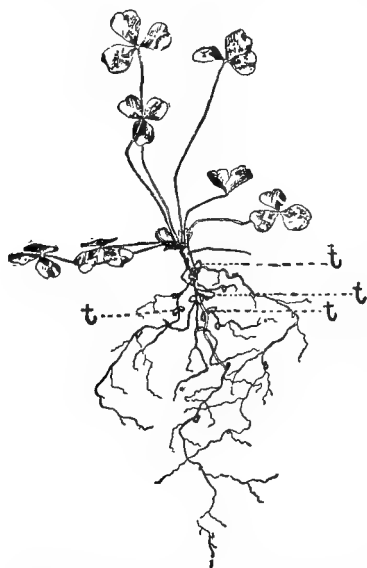

FIG. 33. — Young clover plant showing tubercles on roots (*t*).

often grow upward as well as in other directions. At the Geneva Experiment Station, numerous roots of sweet corn were found within an inch of the surface, and in a tall-growing southern corn, roots of considerable size started at a depth of only half an inch. The main root of a Hubbard squash vine was traced a distance of ten feet, in which its depth varied from two to five inches. In tobacco fields, the rootlets sometimes literally protrude from the surface of the soil in warm, wet weather (231).

110. The rate of root growth in rapidly developing plants is often extremely fast. President Clark, formerly of the Massachusetts Agricultural College, concluded from very careful examinations and measurements of the roots of a squash vine grown under glass, that rootlets must have been produced at the rate of at least one thou-

sand feet a day during the latter part of the growth period.

111. Relation of roots to food supply. — In the extent of ground occupied, root growth is relatively less in moist and fertile soils than in poorer and drier ones, but the roots are proportionately more branched. In wet seasons, a given plant has less extensive root development than in drier seasons, because the roots may then secure the needed food and water from a smaller area. Nursery trees grown on fertile soils have a more compact root system than those grown on poorer soils.



FIG. 34. — Part of a growing potato plant. The whole plant has been developed from the dark-colored tuber in the center.

112. Root tubercles. — Plants belonging to the natural order Leguminosae, of which the clover, pea and bean are familiar examples, when grown in ordinary soil have swellings or tubercles on their roots (Fig. 33). These are caused by micro-organisms, of the class known as bacteria, and are of special interest, because the organisms producing them render the nitrogen of the air available as plant food. Plants have no power to utilize directly the free nitrogen of the air (259).

THE STEM

113. The parts. — As the root develops from the base of the hypocotyl, the plumule, or primary shoot (55), develops from the other end and becomes, at least for a time, the main axis or stem.

114. The stem is, generally speaking, the part of the plant that supports the leaves. In exceptional cases, as in the potato (Fig. 34) and quack-grass, a part of the stem grows beneath the ground, on which the leaves usually do not develop (underground stems); and in a few plants, as in some cacti, the stem performs the whole office of leaves. The stem may be strong enough to support its own weight, as in trees and shrubs, or it may depend upon other objects for its support, as in vines.

115. Nodes and internodes. — Unlike the root, the stem is developed in successive sections, comparable in part to the stories

of a building. Each section or story consists of one or more leaves, attached to the distal end of a part of the stem. (Distal means farthest from the point at which growth started. It is opposed to proximal, which means nearest the point of origin.) The part of the stem to which the leaf or leaves are attached is called a node and the part below the node, or in the stem as

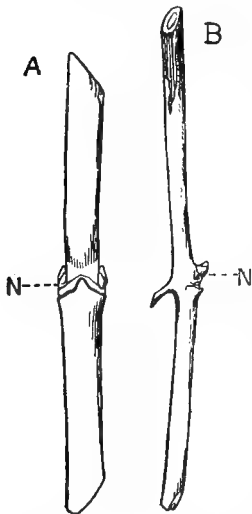

FIG. 35. — Nodes (N); A, of the box elder, *Acer Negundo*; B, of the wild grape, *Vitis riparia*.

a whole, the part between the nodes, is called an internode.

The nodes are distinctly marked in the younger stems of most plants by a slight enlargement or by leaf-scars, if the leaves have fallen (Fig. 35). The nodes are centers of vital activity and are points at which lateral growing points (buds, 127) are normally formed, and whence roots usually start first in cuttings and layers (358, 349).

116. Lengthening of stem. — The stem lengthens by elongation of the internodes, as well as by the formation of new ones. As the internodes soon attain their ultimate length, it follows that the stem lengthens only near its distal end. An internode that has once ceased elongating does not usually resume it, hence the internodes of perennial plants that are only partly elongated at the close of the growing season in general remain undeveloped. When growth is resumed in spring, the formation of a comparatively long internode beyond the very short ones of autumn usually forms a perceptible ring about the shoot, which enables us to readily locate the point at which growth started in the spring (Fig. 36). Indeed we can often determine the amount of growth that took place during the preceding season or even farther back.



FIG. 36. — Union of new and older wood.

117. Length of internodes. — The ultimate length of the internodes in any plant, or any part of a plant, depends upon the rate of growth — rapid growth producing long internodes, and *vice versa*. In the same species, therefore, the average length of the internodes is much greater in

vigorous young plants than in old ones; in the main, central shoot than in the branches, and when growth is well started in spring than during its decline in autumn. The diameter of young internodes that are not unduly shaded is generally in proportion to their length, hence rapidly-growing shoots are usually thicker than slower-growing ones. We can judge of the comparative vigor of nursery trees by observing the length and diameter of the internodes.

118. The stem elongates fastest just behind the growing point (66), and at least in young plants, just behind the primary original growing point (55). When we desire to check the growth of the stem, therefore, we remove the terminal growing point by pinching (416).

119. Pinching stimulates branching because removing the terminal growing point stimulates the development of other growing points farther back (104).

CHAPTER V

LEAVES, BUDS AND FLOWERS

Now we are ready to consider the leaf, the bud, and the flower. To the beginner in plant study, these three parts may seem to be wholly unrelated, and yet we shall find, as we proceed, that they are all forms of foliar parts. We have seen that one or more leaves are normally formed at each node of the stem (115); and we shall find a similar arrangement for buds and flowers.

THE LEAVES

120. The function of leaves is food preparation (58). Since food is prepared only in the light, the cells of leaves are in most plants so arranged as to best expose them to light, *i.e.*, in thin, more or less horizontal plates, which are strengthened and at the same time supplied with water by a network of vascular bundles (67) connecting with the stem. They are protected by the epidermis (64), but have access to air through the stomata (65).

Each leaf, like the stem and root, is developed from one or more growing points (66), located near the base. Cell division in the leaf is confined to the near vicinity of the growing points, hence an injury to the older part of the leaf is not repaired further than by the formation of callus (72) over the wounded parts.

121. Leaf development. — The cultivator should provide for normal leaf development. Since the protoplasm of the plant is nourished by prepared food (58), and since food preparation in most plants takes place almost wholly in the leaves (120), it is of first importance that the plant be so cared for as to promote normal leaf development. Without this, good crops are impossible. The plants must be grown far enough apart so as not to unduly shade each other; insects and fungi must not be permitted to prey upon them when it is possible to prevent it; and the leaves must not be needlessly removed or injured. The more severe the climate, the more important is perfect foliage, because more reserve food is required to endure a long, severe winter than a short, mild one.

122. Distance apart to grow plants. — When the finest developed plants, or parts of plants, as fruits, flowers, leaves, stems or roots, are desired, the plants should not be grown so near together as to interfere with each other's leaf or root development. But when the largest crop from a given area is of more importance than the development of the individual plant, as with grain crops, the loss from a limited amount of shade and crowding will be more than made up by the increased number of plants. In this case, the amount of crowding that will give the maximum yield will depend much upon the fertility and moisture of the soil, and must generally be determined by experiment.

123. Number of leaves — Stem and root development depends on the number of leaves. Since the vascular bundles, through the formation of which the stem and root increase in diameter, originate in the leaves (67), the size and firmness of the stem and the root depend somewhat upon the number of leaves the plant bears.

The more leaves it has, the more solar energy it can transform into plant tissue. The stem is larger beneath a vigorous leafy branch, and if cut off some distance above a branch, the part thus deprived of its foliage ceases to grow, unless it develops new leaves. Trees growing in the dense forest, where their lower branches continually perish through lack of light, have tall, but very slender trunks, and their wood is soft because it contains comparatively little fibrous tissue, while other trees of the same species in the full light of the open field, through the large amount of solar energy absorbed by an immense number of leaves, develop massive trunks, of which the wood, being packed with fibrous tissue, is much stronger than that of the forest tree.

124. The comparative size of leaves on a given plant depends much on the water supply during their formation. The leaves of sap-sprouts (223), that take an undue proportion of water, are usually very large, and in upright-growing plants, the leaves on the more nearly vertical shoots are usually larger than those on the horizontal ones. The more vigorous the plant, the larger, as a rule, are its leaves, and the softer is its woody tissue.

In plants grown from seed to secure new varieties, large leaves may be taken as evidence of superior root development, which implies capacity to endure drought and, therefore, hardiness. In the apple, the large-leafed varieties are, as a rule, hardier than others, probably because their vigorous roots supply the needed water during the dry season, thus enabling the tree to mature healthy wood and buds which can pass severe winters unharmed (174).

Crops grown for their leaves, as cabbage, lettuce, tobacco and the like, are especially liable to be curtailed

by drought, and hence should be given the culture that best promotes soil moisture, as abundant surface tillage and liberal manuring (231).

125. Life of a leaf. — Leaves are usually short-lived because they become clogged with those mineral matters taken up with the soil water which are not used by the plant (63) and which do not pass off in transpiration (74). In most annual plants (337), the older leaves become useless from this clogging and die before the stem is fully developed, and in most perennials the leaves endure but a single season. In the so-called evergreen plants, in which the leaves are usually very thick and are often well protected against evaporation by a very strongly developed cuticle (64), the leaves rarely live more than a few years.

126. The manurial value of leaves that mature on the plant is usually small, since the more valuable fertilizing materials they contain pass into the stem before the leaves ripen (170). The mineral matters contained in largest quantity by leaves are those that are not used by the plant, but have been deposited with them during transpiration (125).

THE BUDS

127. The buds. — Each tip of the stem (66) is in most plants protected with a covering of rudimentary leaves or leaf-scales, and the tip with its leafy or scaly covering constitutes a bud. A bud forming the apex of a shoot is called a terminal bud; one at the junction of a leaf with the stem (axil) is called an axillary or lateral bud (Fig. 37).

Each bud generally includes one terminal and several axillary growing points. Aside from these, which in the stem exist only in the bud, a bud is simply a part of the

stem in which the leaves and internodes are in the embryo stage.

In most perennial plants, the rudimentary leaves that form near the latter end of the growing season are changed into bud-scales, which serve to protect their growing points from excessive transpiration (74). Axillary buds which have not yet expanded are clothed with similar scales. Buds inclosed with scales are often called winter buds. To shut out water more effectually, the scales are coated with a waxy or resinous layer in some plants, as the horse-chestnut and balm of Gilead, and to protect them further, especially against excessive transpiration and light when they first open, they are lined in other plants, as the apple, with a delicate cottony down. A vertical section of the onion bulb may be used as a magnified illustration of a bud as it appears in winter, and that of a head of cabbage of a bud unfolding in spring.

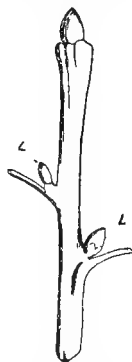

FIG. 37.—Buds. *L*, lateral buds.

128. Lateral buds.—Nature provides very early for the next year's growth in perennial plants. With the expansion of each leaf, a bud begins to form at its axil, destined if need be to become a branch at a later time. Sometimes, however, especially in very vigorous shoots, the embryo buds at the axils of the earliest formed leaves remain undeveloped.

129. Branches develop from lateral leaf-buds (131). In trees and shrubs (woody perennials), the lateral buds do not usually push into growth until the spring after their formation, unless the terminal bud is injured. In-

deed, they may never push into growth. Some lateral leaf-buds (131), especially those most distant from the terminal bud, usually remain dormant, through want of light or nutriment, and are overgrown by the enlarging stem the following year. They are then called latent buds. Stimulated by destruction or injury of the stem above, dormant buds sometimes push into growth years after their formation.

We can usually decide whether detached dormant shoots of trees and shrubs, as cions and cuttings, are of the preceding year's growth or older, since, as a rule, only wood formed the preceding year has visible undeveloped buds. (Exceptions to this rule are not uncommon in unthrifty trees and shrubs.) A bud, in pushing into growth, consumes reserve food from the parent branch. The more horizontal a branch the smaller is the supply of water to its buds.

130. Adventitious buds. — Although buds are normally formed only at the nodes of the stem, they may under the stimulus of unusual water and food supply (101) be formed without regard to nodes. The trunk of a vigorous elm, willow or horse-chestnut tree, cut off early in the season, often develops a multitude of buds from the thickened cambium (68) at the top of the stump, and a circle of shoots often spring up about the base of a tree of which the top has been injured by over-pruning or severe cold. Such buds are called adventitious. It is, however, often difficult or impossible to distinguish between adventitious and latent buds (129).

The roots of many plants, as the plum, choke cherry and raspberry, develop adventitious buds freely, especially when injured, a fact often utilized in propagation by root cuttings (376).

131. Leaf-buds and flower-buds. — Buds may contain only rudimentary leaves, or they may contain rudimentary flowers, with or without leaves. The former are called leaf- or wood-buds the latter flower- or fruit-buds. Flower-buds are modified leaf-buds. Both originate in the cambium layer (68) and are normally located at the apex of the stem or in the axil of a leaf (127–128).

132. Differences between leaf- and flower-buds. — Flower-buds are often

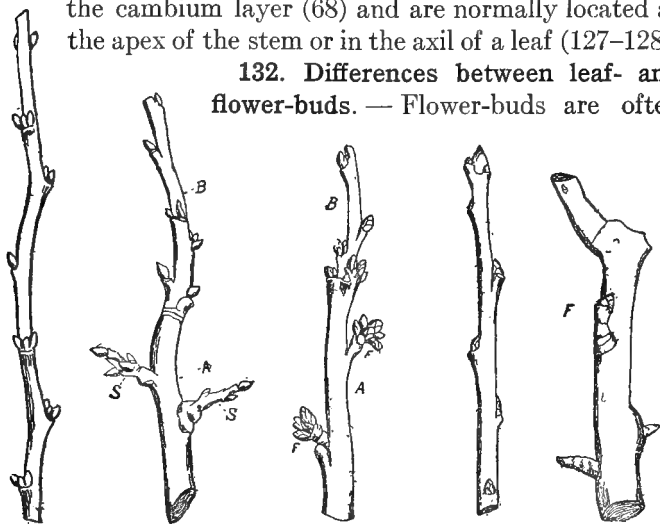

FIG. 38.

FIG. 39.

FIG. 40.

FIG. 41.

FIG. 42.

FIG. 38. — Flower-buds of Pottawattamie plum, *Prunus angustifolia*. The central bud of each group is a leaf-bud.

FIG. 39. — Fruiting branch of European plum, *Prunus domestica*. *B* young wood. *A* wood of preceding year. *S* fruit spurs.

FIG. 40. — Fruiting branch of Morello cherry, *Prunus Cerasus*. *B* young wood. *A* wood of preceding year. *F* clusters of fruit-buds.

FIG. 41. — Leaf-buds of the apple.

FIG. 42. — Fruit-bud of apple (*F*). All are reduced one-half.

readily distinguished from leaf-buds, by location and appearance, the same season in which they are formed, which enables the fruit-grower to anticipate his crop. In the peach and apricot, and in many varieties of

plum, a flower-bud is normally formed on each side of the leaf-bud in the young shoots of bearing trees (Fig. 38). In the apple and pear, the flower-buds are less definitely located, but are mostly formed on the short, thick, wrinkled and crooked branches from wood three or four years old (fruit spurs, Figs. 42 and 43). In some fruits, as the apple, cherry and peach, the flower-buds are usually thicker and more rounded than the leaf-buds, especially toward spring. Close and persistent observation will enable the horticulturist early to distinguish the flower-buds in many of his perennial plants.

In the apple and pear, the buds on the so-called fruit-spurs are not necessarily flower-buds, but some seasons all are leaf-buds. How early in the life of a bud its character is fixed, or if flower-buds ever change to leaf-buds before expanding, does not appear to be known. The fact that leafy shoots sometimes grow out of the center of flowers, and that petals (142) are sometimes developed as leaves, suggest that such change may occur.

In the grape, flowers appear at the first two, three or four nodes of the young shoots that grow from stems formed the preceding season (canes) and the shoot continues to grow beyond the flowers. The raspberry, blackberry and dewberry bloom like the grape, except that the shoots terminate in a flower. In the strawberry, the terminal bud of the preceding year's growth flowers in early spring. In these plants, therefore, the flower-buds are inclosed by the same bud scale that incloses the leaf-buds, hence, it is more difficult to foresee the number of flowers than in the tree fruits. A knowledge of the location of the flower-buds is very important in pruning plants grown for their flowers or fruits (416).

133. Vigor of leaf-buds.—The comparative vigor of leaf-buds on a given shoot depends somewhat upon their location and the length and diameter of the internodes. The terminal bud, when uninjured, is usually the most vigorous one, and the vigor of the buds, as a rule, diminishes as we recede from the terminal bud. The more rapid the growth of the shoot, the less developed, as a rule, are the lateral buds. Cions (386) and cuttings (358) should not, therefore, be taken from excessively vigorous shoots. The more vigorous buds are often more sensitive to cold than the less vigorous ones, since they are usually farther developed the season in which they are formed, hence the terminal buds are most often injured in winter.

In the potato tuber, which is the thickened terminus of an underground stem (Fig. 34), the most vigorous shoot comes from the terminal bud (the so-called seed-end), hence rejecting this part of the tuber in planting, as has often been recommended, is detrimental to the crop.

134. Conditions affecting the formation of flower-buds.—Most cultivated plants are grown either for their flowers or the product of their flowers, *i.e.*, fruit or seed. But the flower is not an essential part of the plant, and instead of contributing to its welfare, as do the leaves and roots, it actually consumes a part of the plant's reserve food (139). As might be expected, therefore, perennial plants do not always produce an annual crop of flowers, even when well developed in other directions, hence the grower is often disappointed. Since flowers can only come from flower-buds, a knowledge of the laws that govern the formation of these would often be valuable to the cultivator. Unfortunately, this subject has received less

attention than is due to it. Two principles may be cited, however, which if they do not explain all phenomena connected with the formation of flower-buds, are of sufficient general application to have great economic value, viz.: Plants form flower-buds only when they contain reserve food (84); water supply insufficient for rapid growth may suffice for abundant food formation (59).

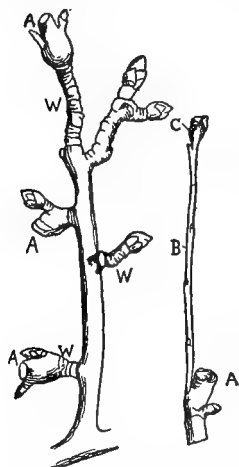

FIG. 43. — Fruit-spurs of the apple. *A* points at which apples were detached the preceding year; *W* wrinkles marking points at which leaves were detached in previous years.

In support of the first of these propositions, we mention: (a) Rapidly-growing plants rarely form many flower-buds, because the food is used up in growth as fast as formed. (b) Checking such rapid growth, by removing the growing points of the stem or root (67), or by withholding water, results in an accumulation of food and is often followed by an abundant formation of flower-buds. (c) Obstructing the rootward current of prepared food (79), as by “ringing” (416) causes an accumulation of food above the obstruction and is often followed by the formation of flower-buds in that part.

In support of the second proposition we mention: (a) Florists often bring their plants into bloom at a desired time by withholding water. (b) The flower-buds of most out-door plants are formed during the drier part of summer (plants that live over winter and bloom in spring, as the apple, strawberry and the like, form their flower-

buds the preceding season), when a restricted water supply prevents rapid growth, but when abundant sunlight and fully-expanded foliage favor food formation (59).

We may infer, therefore, that treatment that favors the accumulation of reserve food promotes the formation of flower-buds, a proposition that is borne out by the experience of practical cultivators.

135. Promoting accumulation of plant-food. — Three general principles may be cited for promoting the accumulation of reserve food :

Provide for abundant food formation by giving sufficient light and air and by protecting the foliage from attacks of insects and fungi ; provide sufficient plant-food in the soil to satisfy all requirements of food formation ; provide for a moderate check to growth after the proper amount of growth has been secured.

In the greenhouse where conditions are under control, these principles are readily followed, and the skilled florist rarely fails to secure bloom at the proper time. He gives the desired check to growth by permitting the roots to become densely matted in the pot (pot-bound), by withholding water, or by pinching the tips of the more vigorous shoots. With out-door perennial plants, as fruit trees, the problem is more difficult, since conditions are less under control than with plants under glass, but the principle just cited should always be kept in mind and carried out so far as possible.

We can give sufficient light and air by planting the trees a sufficient distance apart (122) and by proper pruning (Chap. IV).

If the soil is properly drained, the natural depletion of soil water about midsummer will usually give the

needed check to growth. In wet seasons, the drying of the soil may be promoted by stopping cultivation before midsummer and sowing a crop that will increase evaporation from the soil, as oats, clover or buckwheat (200).

136. Pinching to promote flowering.— In certain cases, as with seedling trees of which we would early know the quality of the fruit, we may give an abnormal check to growth by pinching the tips of the young shoots or by root pruning (416). These operations should be performed early in summer, before the period of flower-bud formation, and if the tree is not too young, flowers and fruit may be expected the following season. Frequent transplanting of young trees acts like root pruning, especially if the tap-root is severed. Such harsh measures, however, while they promote early fruiting, doubtless tend to shorten the life of trees.

137. Ringing (415) often causes the formation of flower-buds in otherwise barren trees, by obstructing the rootward current of prepared food. Twisting a small wire about the branch, violently twisting the branch itself, or simple bending and fastening it in an unnatural position, answers the same purpose. But these devices probably weaken the tree and shorten its life by robbing the roots of their normal food supply and are excusable only in special cases, as with seedling trees. It is generally a reproach to the care or knowledge of the cultivator, if his trees of bearing age cannot form flower-buds without such choking.

Fruit-trees grafted on slightly uncongenial stocks sometimes flower and fruit more freely for a time than when growing on their own roots, because the imperfect union of cion and stock (383) forms an obstruction to the rootward food-current.

THE FLOWER

138. The flower is the developed and expanded flower-bud (131). Its office is to provide for the formation of new plants of its kind (reproduction, 16). Some plants, as the quack-grass (*Agropyron repens*), Canada thistle (*Cirsium arvense*) and horseradish (*Radicula*), multiply freely in nature without the aid of flowers, and nearly all plants may be multiplied in culture by other means, but in most of the higher plants, the flower is the natural organ of reproduction, and the only organ devoted solely to this end.

139. Effect of flowers. — Flowers tend to exhaust the plant, since they are formed from the food prepared by the leaves. But since flower-buds are not usually formed until the needs of growth are provided for (134), the normal production of flowers does not injure the plant. In certain cases, however, as in plants weakened by recent transplanting or in cuttings (358), flower-buds should be removed as soon as discovered, to prevent their exhaustive influence.

140. Parts of the flower. — The complete flower is composed of four different parts or organs. A knowledge of these parts is of great importance to the botanist in determining species, and also to the plant-breeder who would practice cross-pollination (151, 440), hence we need to consider them in detail. The cherry blossom, of which a vertical section appears in Fig. 45, will serve as our first example.

141. The calyx. — Beginning at the bottom, the part marked *C* in the figure is called the calyx. This is green in the normal cherry flower. In some plants, as the flax, the calyx is composed of several distinct, more or less

leaf-like parts, each of which is called a sepal. In the cherry blossom, the sepals are united nearly to the top. The calyx is usually green, but in the tulip and some other flowers it is of another color. In the apple and pear, the calyx becomes a part of the fruit, and its points are visible in the depression opposite the stem.

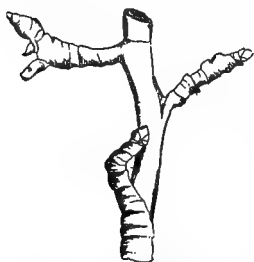

FIG. 44. — Fruit spur of the pear. Reduced one-half.

petals. In many plants, as the pumpkin and morning glory, the petals are united. In other plants they are united a part of the way to the top. The corolla is usually of some other color than green.

143. The stamens. — Inside the corolla is a group of slender organs (*SS*, Fig. 45), called stamens. Each stamen consists of

three parts, viz., the long and slender portion, connected with the calyx below, called the filament; the swollen part at the top, called the anther; and the yellow dust found upon or within the anther, called the pollen.

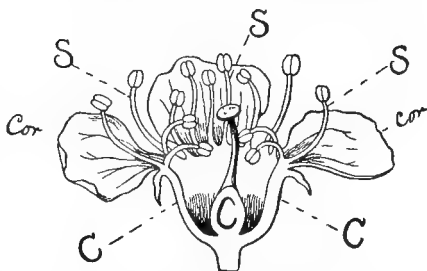

FIG. 45. — Section of cherry blossom. *C* calyx; *Cor.* corolla; *S* stamens.

Each grain of pollen is a single cell, which if fertile (152) contains living protoplasm. The pollen is set free at maturity.

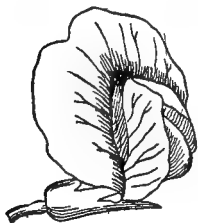

FIG. 46. Flower of the pea,
Pisum sativum.

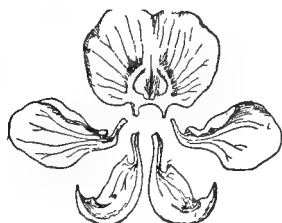

FIG. 47. — The same dissected,
showing variation in form of
the petals.

144. The pistil. — The column-like part in the center of the flower is called the pistil. This also consists of three principal parts, viz., the enlarged flattened summit, called the stigma; the egg-shaped base, called the ovary; and the slender part connecting the two, the style. The ovary contains a smaller, egg-shaped part, called the ovule, which when developed becomes the seed. Many flowers have more than one pistil, and many ovaries contain more than one ovule.

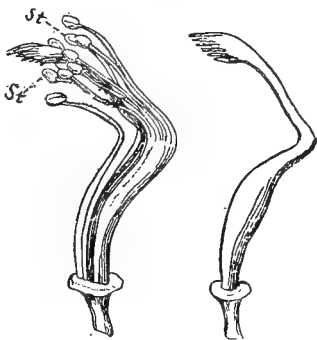

FIG. 48.

FIG. 49.

FIG. 48. — Stamens (*st*) and pistil
of the pea, *Pisum sativum*.

FIG. 49. — Pistil of the same alone.

Recapitulating, the parts of the flower are, in the order we have considered them :

a — The calyx; when divided, the parts are called sepals.

b — The corolla; when divided, the parts are called petals.

c — The stamens; the parts are the filament, anther and pollen.

d — The pistil or pistils; the parts are the stigma, ovary and style.

The ovary contains the ovule or ovules.

145. Variation in form. — The parts of the flower vary in form in different species. In the pea flower (Fig.



FIG. 50. — Cross-section of flower-head of sunflower, *Helianthus annuus*. Reduced. The florets appear closely crowded in the center of the head.

46) the five petals, shown separately in Fig. 47, are not only quite unlike the petals of the cherry flower, but as appears, they are unlike each other. The stamens (Fig. 48 *st*) and the pistil (Fig. 49) of the pea are also quite different in form from those of the cherry: The

variety of form in the parts of the flowers of different species is almost infinite.

146. Abortive parts. — Certain parts of the flower are often wanting. The flowers of the maple have no corolla; those of the willow have neither calyx nor corolla; certain flowers of the pumpkin, Indian corn

and many other plants have no stamens, while other flowers of the same species have no pistils (153). In many varieties of the American plums (*Prunus americana*, *P. angustifolia*, *P. hortulana*) the pistil is often wanting.

147. Composite flowers¹ are made of several individual flowers in the same flower-head. The sunflower (Fig. 50) is a familiar example of a composite flower. One of the separate flowers is shown in Fig. 51. At the outer edge of the flower-head, is a row of individual flowers, each of which has a long, yellow, petal-like appendage (Fig. 52), called a ray. The flowers bearing rays are called ray-flowers. Some composite flowers as of the tansy (*Tanacetum vulgare*) are without ray-flowers.

148. The flowers of the grass family (*Gramineae*) to which the cereals belong, as well as corn, sorghum, sugar cane and the like, are quite different from those of most other plants. In this family, the flowers are arranged in little groups, each of which is called a spikelet. What we call a head of wheat is made up of a number of spikelets, one of which is shown in Fig. 53. Fig. 54 shows the spikelet dissected. The two scale-like parts at the base, *g, g*, are called glumes. Above these on either side is another scale, flowering glume or lemma, tipped with a bristle (the awn or beard). Wrapped within this is

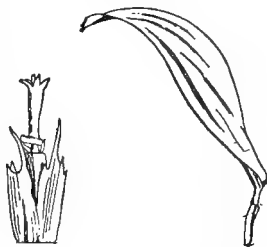

FIG. 51.

FIG. 52.

FIG. 51. — Enlarged floret of sunflower.

FIG. 52. — Ray-flower of same.

¹The plants having composite flowers form an extensive family in botany, called Compositae.

another more delicate scale, palea, together with the stamens and pistils (Figs. 53–55).

149. Fecundation is the union of the male and female cell by which the new plantlet is formed. The term fertilization that has been commonly used for this process tends to confusion, because this term is also applied to the addition of plant-food to the soil. The ovule produces within itself a female cell which may be fecundated



FIG. 53.

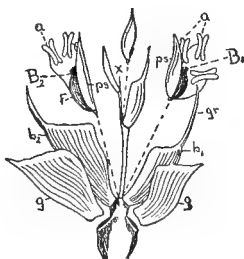

FIG. 54.

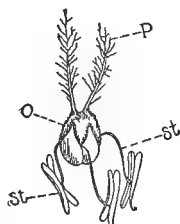

FIG. 55.

FIG. 53. — Spikelet of wheat; *st* stamens.

FIG. 54. — The same dissected; *x* axis of spikelet; *g* glumes; *b*₁, *b*₂, flowering glumes; *B*₁, *B*₂, flowers displaced from the axis of flowering glumes; *ps* palea; *a* anthers; *f* ovary.

FIG. 55. — Flower of wheat, enlarged; *st* stamens; *p* pistil; *o* ovary.

by the male cell produced by the pollen (143). The fecundated cell then grows to form a young plant — the embryo (55), and the parts of the ovule develop about it, the whole forming the perfect seed. Unless the ovule is fecundated, the seed very rarely develops. A flower that contains no pistil, and hence no ovule, can of course produce no seed.

150. Pollination is the access of pollen (143) to the stigma (144) — the first step in the process of fecundation. During a certain period, the surface of the stigma is

moistened by the secretion of a viscid liquid, to which the pollen grains readily adhere. Fertile pollen grains (pollen that is capable of fecundating female cells of its own species) alighting on the stigma of sufficiently near-related plants during this period, undergo a process comparable to germination, in which a slender projection from the pollen cell penetrates the stigma, passes lengthwise through the center of the style and enters the ovule, where fecundation occurs.

Pollination is not necessarily followed by fecundation. In young plants, and in older plants that are lacking in vigor (9), flowers often fail to produce seed or fruit, even when pistil and stamens appear to be normally developed, and pollination occurs. Pollen is probably more profuse and more potent some seasons than others.

In some flowers, as in the pea, the stigma is brought into direct contact with the pollen by the elongation of the style, but in most plants the pollen must be transferred to the stigma by some outside influence, as by insects, the wind or gravity. Most flowers which have a showy corolla or calyx, or secrete nectar, or yield a fragrant perfume, depend largely upon the visits of pollen-loving or nectar-loving insects for pollination. The showy parts and the perfume serve as signboards to direct the wandering insects to the flowers. Pollination is favored by a warm, dry atmosphere.

151. Cross-pollination occurs when the stigma receives pollen from a plant of a different variety or species (21). The offspring resulting is a hybrid (23). Cross-pollination is often performed artificially (440).

Close- or self-pollination occurs when the stigma receives pollen from its own flower or plant.

152. Advantages of cross-pollination. — Cross-pollination is advantageous in plants, as Darwin's careful experiments have shown. The seeds formed are usually more numerous and larger and make more vigorous plants than with close-pollination. Especially is this true when the parent plants have been subjected to different growth conditions in previous generations. Nature favors cross-pollination in perfect-flowered plants by numerous adaptations tending to prevent self-pollination, as maturing the pollen either before or after the receptive stage of the stigma, or so locating the stamens that the pollen is not readily deposited on the stigma of the same flower.¹ In some cases, pollen is infertile on the stigma of the same flower or plant that is abundantly fertile on stigmas of other plants of the same species (154).

153. Perfect, monœcious and diœcious flowers. — Flowers containing both stamens and pistils (or pistil), as in the apple, tomato, cabbage, etc., are called perfect or hermaphrodite; those containing but one of these organs, as in the melon, Indian corn and so on, are called imperfect or unisexual. Flowers of the latter class are called monœcious when the stamen-bearing (staminate) and pistil-bearing (pistillate) flowers are both produced on the same plant, and diœcious when produced on different plants only, as in the hop and date. In a few plants, as the strawberry (154) and asparagus, some individuals produce perfect, and some imperfect, flowers.

154. Planting with reference to pollination is important in certain plants. All diœcious plants (153) intended for seed or fruit must have staminate and pistillate plants growing near together or they will not be

¹ Darwin's work "On the Fertilization of Orchids by Insects" describes many most interesting adaptations of this sort.

productive. The hop plant, persimmon and date palm are of this class.

The flowers of many of our most productive varieties of strawberry yield little or no pollen and are unproductive, unless growing near pollen-bearing sorts (Figs. 56, 57). In many varieties of American plums and in certain varieties of the pear and apple, the pollen, even though produced freely, is infertile on stigmas of the same variety. To insure fecundation, it is wise to mingle varieties in fruit plantations rather than to plant large blocks of a single variety.

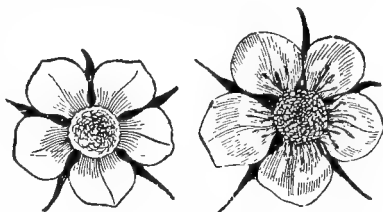

FIG. 56.

FIG. 57.

FIG. 56. — Imperfect flower of the strawberry.

FIG. 57. — Perfect flower of same. The numerous pistils appear in a circular mass at the center, around which the stamens are seen.

CHAPTER VI

THE FRUIT AND THE SEED

THE fruit, as the term is used in botany, is the mature ovary with its contents and adherent parts; it may be hard and dry, as in the wheat and bean, or soft and pulpy, as in the apple and melon. But in common language the term fruit is limited to the pulpy and juicy part of certain plants that contains or supports the seed or seeds or that is an after-development of the flower. To avoid explaining botanical terms, we use the word in the latter sense. In this sense, the fruit serves the plant by attracting animals that can assist in disseminating the seed.

The seed, as we have seen, is the fecundated and mature ovule (144), and its normal office is reproduction (16).

155. Development of fruit. — The fruit rarely develops without fecundation of the germ cell of the ovule (149). Varieties of the apple and pear have appeared, however, in which the pulp develops without seeds. The fruit of the banana is almost invariably seedless. The cucumber, grape, orange and fig sometimes develop their fruit without fecundation of the germ cell. These instances are all exceptions to the general rule.

156. Exhausting the plant. — Seed production exhausts the plant far more than other plant processes. The seed prepares little or no food, while it removes from other parts

of the plant a comparatively large amount of prepared food, which it stores up in a concentrated form as a food supply for the embryo (54). Many plants (all annuals and biennials) are killed the first time they are permitted to seed freely, and perennials are often weakened by excessive seeding. Double-flowered varieties of the annual larkspur (*Delphinium*), that bear no seed, have become perennial.

157. Prevention of seeding prolongs the life of plants. — Many annual flowering plants, as sweet peas, dianthus and the like, that soon perish when permitted to mature their seed, continue to bloom throughout the summer if the flowers are persistently picked. The yield of cucumbers, peas, beans and other garden crops, of which the product is gathered immature, may be considerably increased by preventing the ripening of seed.

158. Overbearing should be prevented. Certain varieties of some of our cultivated fruits, as the apple, plum and peach, tend to devote an undue amount of their reserve food to fruit and seed production in favorable seasons, which if permitted, results in enfeeblement or premature death. The wise cultivator guards against this tendency by thinning the fruit before it has made much growth, thus saving the tree from undue exhaustion and improving the quality of the fruit allowed to mature.

159. Thinning should be performed as early as the fruits can be properly assorted, and the more imperfect ones should always be removed. The proper amount of thinning will depend upon many conditions, as age and vigor of tree, abundance of crop, fertility of soil, water supply, and so on. It must be determined by judgment and experience. Thinning does not increase the total crop but it may enhance its value.

160. Seeding of fodder crops. — The maturing of seeds injures fodder crops. The food value of straw, from which the ripe grain has been threshed, is comparatively small, and that of grass and other crops intended for coarse fodder is much reduced by permitting the seed to ripen before cutting.

161. Ripening of fruits. — Green fruits assist the leaves in food preparation to some extent, but as they begin to ripen, the process is reversed. Carbonic acid and water are then given off, while oxygen is absorbed. Fruits first become sour from the production of acids which disappear in part at a later stage, while sugar is notably increased. Ripening is favored by warmth and in some fruits by light.

Some fruits, as the strawberry and peach, increase rapidly in size during the ripening period, provided the water supply is sufficient.

Color is not always an index of maturity. Blackberries, currants and certain other fruits improve in edible quality for some time after assuming their mature color.

Most fruits that have attained nearly normal size ripen to a degree when detached from the parent plant. Pears are usually improved in quality if picked before maturity and ripened in-doors. The grape, however, fails to develop its sugar if prematurely picked.

After a certain stage of maturity is reached, all vital processes in the pulpy part of the fruit cease, and disorganization (decay) begins, unless prevented by a preservative process.

THE GATHERING AND STORING OF SEEDS

162. Time of germination. — The stage of maturity at which seeds will germinate varies greatly in different plants

and bears no direct relation to the time at which the seeds are set free from the parent plant. Seeds of the tomato will germinate when the fruit is little more than half-grown, and those of the pea will germinate when fit for table use. Seeds of the lemon sometimes germinate within the fruit. On the other hand, seeds of the thorn (*Crataegus*) and juniper rarely germinate until the second spring after their production. Seeds of many annual and biennial plants, as the cereals, cabbage and the like, may germinate as soon as set free by the parent plant, but those of many annual weeds and of most trees and shrubs will not germinate until some months afterwards.

Seeds necessarily gathered immature will often ripen sufficiently for germination if a considerable part of the plant is plucked and cured with them.

Germinating seeds in which the germination process is stopped by undue drying are not always destroyed. Germination may be resumed on access to water. Seeds of different species differ widely in this respect. Those of the parsnip and carrot cannot endure much drying during germination, while those of the cereals may be repeatedly dried at ordinary temperatures without destroying their vitality.

163. Immature versus ripe seeds. — Seeds not fully grown lack a part of their normal food supply, and their embryo is probably imperfectly developed. If capable of germination, they rarely produce vigorous plants. As a rule, the most vigorous plants come from fully-matured seeds. Immature seeds, persistently used, may tend to reduce vigor, and cause early maturity, dwarfing and shortened life. In some over-vigorous plants, as the tomato, slightly immature seed may tend to increased fruitfulness.

Slightly immature seeds usually germinate sooner than fully-matured ones.

164. Length of seed viability.—The viability of all seeds is limited by age, but the duration of the vital period varies greatly in different species. Seeds of the chervil rarely germinate if much more than one year old, while those of the gourd family, the tomato and celery

	DURATION OF GERMINATING POWER			DURATION OF GERMINATING POWER	
	Av. Yrs.	Ext'm Yrs.		Av. Yrs.	Ext'm Yrs.
Artichoke	6	10	Endive	10	10
Asparagus	5	8	Gumbo or okra	5	10
Bean	6	10	Hop	2	4
Bean — kidney	3	8	Kohlrabi	5	10
Bean — soy	2	6	Leek	3	9
Beet	6	10	Lentils	4	9
Borecole or kale	5	10	Lettuce	5	9
Broccoli	5	10	Maize or Indian corn	2	7
Cabbage	5	10	Melon — musk	5	10
Cardoon	7	9	Melon — water	6	10
Carrot 4 or 5	10		Mustard — black or brown	4	9
Cauliflower	5	10	Onion	2	7
Celery	8	10	Parsnip	2	4
Chervil 2 or 3	6		Parsley	3	9
Chervil — sweet-scented	1	1	Pea	3	8
Chervil — turnip-rooted	1	1	Pumpkin	6	10
Corn salad	5	10	Rhubarb	3	8
Cress — American	3	5	Salsify	2	8
Cress — common garden	5	9	Sea-kale	1	7
Cress — water	5	9	Spinach — prickly-seeded	5	7
Cucumber — common	10	10	Squash	6	10
Eggplant	6	10	Strawberry	3	6
			Tomato	4	9
			Turnip	5	10

often germinate well when ten years old. As a rule, oily seeds, as of Indian corn, sunflower and the cabbage family (cabbage, cauliflower, kohlrabi, Brussels sprouts, rutabaga, rape, turnip, mustard), are shorter lived than starchy seeds, as wheat and rice. Oily seeds cannot safely be stored in bulk in large quantities, except in cool weather. The preceding table gives the average period during which the seeds named are reliable for germination, when properly cared for :¹

165. Conditions affecting the duration of seed viability.

— A uniform degree of humidity and temperature tends to prolong the vital period of seeds by causing little drain upon the life of the living cells. Seeds deeply buried in the ground are often capable of germination at a great age, and kidney beans at least one hundred years old, taken from an herbarium, are said to have germinated. In these cases, the seeds were subjected to few variations in humidity and temperature.

Seeds usually retain viability longer when not removed from their natural covering, probably because they are thus exposed to fewer changes of humidity and temperature. Timothy seeds, that become hulled in threshing, lose viability sooner than those that escape hulling, even when the two sorts are kept in the same bag. Indian corn is said to retain viability longer on the cob than shelled, and longer when the ear is unhusked than if husked.

166. Moisture is an enemy to stored seeds, except for the class that requires stratification, as seeds with fleshy coverings and nut seeds (169). A little moisture is very liable to cause the development of fungi (molds) in stored

¹ "The Vegetable Garden," Vilmorin-Andrieux, Paris.

seeds, that may destroy the embryo. Damp seeds are also liable to be destroyed by freezing. It is important that seeds be dried promptly after gathering, for if mold once starts, subsequent drying may not destroy the fungus; the latter may resume growth as soon as the seed is planted, thus enfeebling or destroying the embryo before it has time to germinate. Drying by moderate artificial heat (not higher than 100° F.) is wise with seeds gathered in cold or damp weather.

Seeds are shorter-lived in warm than in cooler climates.

The most satisfactory method of preserving most seeds in quantity is to inclose them in bags of rather loose texture and of moderate size, and to store them in a dry and airy place.

167. Age of seed as affecting the resulting crop. — Seeds grown the same or the preceding season produce, as a rule, more vigorous plants than older seeds. They may not, however, in all cases produce plants that are most productive of fruit or seed, for excessive vigor is generally opposed to reproduction. Cucumber and melon plants grown from seed three or four years old are often more fruitful than those from fresh seeds. In crops grown for parts other than fruit or seed, fresh seeds are undoubtedly preferable, but in crops grown for seed or fruit, fresh seed may not always give as large returns as seed of some age. This subject needs further investigation.

168. Effect of drying on the vitality of seeds. — The vigor of seeds is probably never increased by drying them, but the seeds of most annual and biennial plants may become air-dry without material loss of vitality. The seeds of many shrubs and trees, however, lose vitality rapidly by such drying and those of some species are destroyed

by it. In nature, seeds of the latter class are usually dropped from the parent plant before becoming dry and are soon covered by leaves or other litter that keeps them moist. Nurserymen either plant such seeds as soon as they are ripe, or if of species that do not germinate as soon as ripe, they imitate nature.

169. Stratification of seeds.— This is a process designed to give natural conditions to the mature seed. It consists in mixing the freshly-gathered seeds with sand, taking care that the sand is kept moist until the time for sowing arrives. Large quantities of seeds may be stratified in boxes, by placing the moist sand and seeds in alternate layers, or the layers may be built up in a pile on the ground. The sand should be coarse enough to admit some passage of air between the particles and to give perfect drainage. The layers should not much exceed an inch in thickness, except for the larger seeds, and the number of layers should not be so large as to prevent proper aëration of the mass. Small quantities of seeds may be mixed with sand or porous loam in flower-pots. Moisture may be maintained in the boxes or pots by burying them a foot or more deep in the soil in a well-drained place, or by storing them in a moist cellar. Care is necessary to keep mice and other vermin from stratified seeds. It is well to cover pots in which valuable seeds are stratified, with a sheet of tin or zinc; metal labels are best for distinguishing different sorts of seed. The seeds should remain stratified until sowing time, when they may be sifted out of the sand or sown with it, as is more convenient. Seeds that do not germinate well until the second spring after maturity (162) are commonly left in stratification until that time.

CHAPTER VII

THE DECLINE OF GROWTH AND THE REST-PERIOD

ANNUAL plants usually perish soon after maturing their seed. In other plants, a certain period of vital activity is followed by one in which growth gradually declines until it almost or entirely ceases. In woody plants, the cells become thickened and a part of the rudimentary leaves change to bud-scales, which inclose the growing point (127). In deciduous trees and shrubs, the chlorophyll and starch, with most of the potash and phosphoric acid contained in the leaves are withdrawn into the woody parts (126), while the leaves themselves are detached and fall. The root-hairs also die in many, if not all, plants. The leaves of many trees and shrubs assume striking colors as they approach maturity. In perennial herbs, the nutritive matters in the foliage and stem are withdrawn to the underground parts. A period of almost complete repose ensues, during which the plant, owing to the dormant condition of its protoplasm, is able to endure without harm extremes of temperatures or dryness that would be fatal in its active state.

170. Cessation of growth. — Growth ceases in many trees and shrubs earlier than is often supposed. Most orchard and forest trees of mature age grow little, if any,

after midsummer in the temperate zones. Cultivation, mulching, manuring and wet weather tend to prolong the growth period (199).

171. Occurrence of the rest-period. — The rest-period is not peculiar to the temperate zones, but occurs in the tropics as well. It can be ascribed in part to the change of seasons, as a few familiar examples will indicate. Tubers of the earlier varieties of the potato, that ripen in northern countries by the beginning of August, do not sprout if left in the ground till October, but if stored in a cellar during winter at a temperature little above freezing, they often begin to sprout in March. Bulbs of the crocus, tulip, narcissus, crown imperial and the like, that form in spring, lie dormant in the warm soil during summer and early autumn, but start vigorously in the colder soil of the late autumn or the succeeding spring. The buds of many trees, that form in summer for the next year's foliage and flowers, remain dormant during the hot weather of August and September, to push vigorously in the first warm days of spring. The rest-period is to be regarded as a normal, if not a necessary factor of plant life.

172. Greenhouse plants. — Most plants under glass require rest from time to time, or they do not thrive. The rest is provided either by keeping them at a lower temperature than is favorable to growth, or by submitting them to a degree of dryness that prevents growth. The latter is preferable for plants native in the tropics, where they naturally lie dormant during the dry season.

173. Maturity. — The time of leaf fall is an index of wood maturity in healthy deciduous trees and shrubs. In these, the coloring and fall of the leaves in autumn is not necessarily due to frost, but results from the dormant condition that accompanies maturity. As a rule, the

more mature leaves are precipitated by the first autumn frost. Those less mature usually remain until the more severe frosts. In trees with well-ripened wood, the leaves at the tip of the shoots usually fall before, or not later than, those on the older parts of the tree. With poorly-matured wood the reverse is the case. In a few deciduous trees, as the beech and some oaks, many of the mature leaves remain on through the winter.

174. Hardiness depends upon the degree to which the dormant state is assumed. Since the most severe climatic extremes come during the natural rest-period of plants, the ability of the plant to endure these extremes depends upon the extent to which the protoplasm becomes dormant during the decline of growth. As a rule, a given plant is hardy (10) in a locality in which the duration and the warmth of the growing season are sufficient to complete and fully mature its normal amount of growth. Varieties of the apple and other trees, that so far complete their growth in any given locality that their leaves fall before hard frosts, are rarely injured in winter, while those that continue growth until their foliage is destroyed by freezing suffer in severe winters. Deciduous trees are liable to destruction in severe winters in a climate where none of the leaves fall before hard frosts, as is the case with the peach, apricot and nectarine in northern United States.

175. Acclimatizing. — Individual plants cannot adjust themselves to a new environment, except to a slight extent. The power to complete the annual growth processes and become sufficiently dormant to endure the rigor of the rest period in any given locality is inherited, and not acquired. We are, therefore, able to do very little toward inuring or acclimatizing individual plants to an environment to which they were not adapted by nature. We

may, however, through the variations of offspring (18), secure varieties in some cases that can endure an environment which the parents could not endure.

176. Plant processes during the rest-period may not entirely cease. Although food preparation is wholly suspended, root growth and the callusing (72) of injured root surfaces proceed to some extent during winter in unfrozen layers of soil; and in sufficiently mild weather, the reserve food in the stem gradually moves in the direction of the terminal buds.

177. Cuttings (358) of woody plants are preferably made in autumn in climates of severe winters and buried in the ground below the limit of hard freezing, in order that callusing (72) and the transfer of food may make some progress before the final planting.

178. The "turn of the year." — Toward the close of the dormant season, vegetation, as if benefited by the rest, is prepared to start with renewed vigor, even at moderate temperatures. Buds, that remained dormant during the latter part of the previous summer, push into growth with the first warm days of spring, and many seeds, that could not be induced to germinate the preceding autumn, start with vigor as soon as the soil is sufficiently warm.

The cause for this energetic resumption of plant growth after the rest period is not well understood, but exposure to cold, in the case of temperate plants, and to prolonged dryness in that of tropical ones, doubtless explains it in part, for it is well known that potato tubers may be induced to start their buds soon after maturity by exposing them to the sun a few days, or by placing them for a like time in a refrigerator containing ice. By these means, the farmers of Tennessee grow a second crop of potatoes in the latter part of summer and in autumn.

Plants under glass usually thrive better after midwinter than before, and the most favorable time to plant seeds of greenhouse plants is toward the close of the natural rest-period.

179. The round of plant life has now been traced, from the first swelling of the planted seed, through the development of the embryo into the plantlet, the penetration of the root into the dark and damp soil cavities, the absorption and conduction of water with its food materials in solution, coöperating with the sunlight and carbonic acid in the mysterious laboratory of the leaf, in building up the plant body into node and internode, leaf, bud, branch, flower, fruit and seed; through growth, decline, leaf fall and winter sleep, to the renewed vigor of another spring-time.

In our study of the round of plant life, we have assumed the environment to be favorable. But in the practical culture of plants, we are constantly meeting with adverse conditions of environment. Talent for plant culture lies in the ability to discern these adverse conditions by the appearance of the plant, and in knowing how to correct them. We will, therefore, next consider the plant as affected by unfavorable conditions of environment.

The following books are recommended for reading in connection with the preceding chapter: "How Plants Grow," Gray; "Outlines of Botany," Leavitt; "Lessons with Plants," Bailey; "Plant Anatomy," Stevens; "The Soil," King; "The Fertility of the Land," Roberts; "Plant Physiology," Duggar; "Experiments with Plants," Osterhout.

CHAPTER VIII

THE PLANT AS AFFECTED BY UNFAVORABLE TEMPERATURE

THE plant has now been grown, or well started on its way. We must now determine what hindrances, accidents or injuries may stand in the way or overtake it. We may consider this subject, in successive chapters, under the heads of temperature, unfavorable moisture supply, unfavorable light and winds, insufficient or injurious food supply and parasites.

180. Factors of environment. — The plant environment is mostly comprehended by the terms climate, soil, animals and other plants. But as these are more or less complex influences, it is well to analyze them and to consider separately the component factors of each.

THE PLANT AS AFFECTED BY EXCESSIVE HEAT

181. Relation of heat to transpiration. — Transpiration increases with the degree of heat. The most common effect of heat upon plants is the drooping of the foliage, due to excessive transpiration (74). With insufficient water, this may occur at a temperature that is normal for the plant. But with a water supply that is sufficient at ordinary temperatures, transpiration may be so much

increased by an overheated atmosphere that the roots are unable to supply the plant with sufficient water, hence the cells become partially emptied and the foliage droops. Herbaceous plants in an overheated greenhouse or hotbed are sometimes so prostrated from excessive loss of water as to appear dead, but unless the heat has been sufficient to destroy their protoplasm, or the heated period has been protracted, they will recover when normal temperature and water supply are restored.

182. Effect of heat on evergreens. — Evergreen trees are sometimes destroyed by untimely warm weather in spring. With a soil so cool that the roots are inactive, a sudden rise of atmospheric temperature, especially if accompanied by a drying wind, may so far reduce the water in the leaves of evergreen trees as to cause death of the foliage and even of the trees themselves. This most frequently happens in the seed-bed, in compact nursery plantations, or with recently transplanted evergreen trees. It is most disastrous on poorly-drained clay soils that have a sunny exposure, and at times when the ground is deeply frozen.

The preventives to be observed are: (*a*) means that favor prompt thawing of the ground, as thorough drainage and not too close planting; (*b*) means that prevent, in a measure, exposure to the sun, as planting on a northern slope or shading the trees (414); (*c*) means that tend to prevent deep freezing of the soil, as providing wind-breaks which tend to retain the snow (203). The practices are subject to considerable modification.

183. High temperatures. — A temperature of 122° F. is fatal to the protoplasm of most land plants. Aquatic plants and the more watery part of land plants perish at a somewhat lower temperature. Watery fruits, as

tomatoes and gooseberries, and the younger leaves of deciduous trees, are sometimes destroyed by exposure to the sun's rays in hot weather. An occasional sprinkling of the plants and of the soil about them will usually prevent this result.

184. Sprinkling in sunshine. — Plants under glass should not be sprinkled in bright sunshine. Drops of water upon the leaves of plants often act as lenses in converging the rays of the sun, and in a closed greenhouse or hotbed may cause a heat that is fatal to the foliage beneath them. This may explain the brown spots so often observed upon the leaves of indoor plants that have been sprinkled in bright sunlight, but some of it may be due to inequalities in the glass panes. Sometimes, but rarely, this trouble occurs in the open air.

185. Sun-scald is the term applied to an affection of the trunk and larger branches of certain not quite hardy trees, usually upon the south or southwest side, in which the bark and cambium layer (68) are more or less injured (Fig. 58). In severe cases, the cambium is totally destroyed, and the loosened bark splits longitudinally or becomes detached. The effect is apparently



FIG. 58. — Showing effects of sun-scald on trunk and branches of silver maple tree, *Acer dasycarpum*.

the same as when a tree is exposed to the heat of a fire. Sun-scald is most common in young trees, especially in those recently transplanted or overpruned.

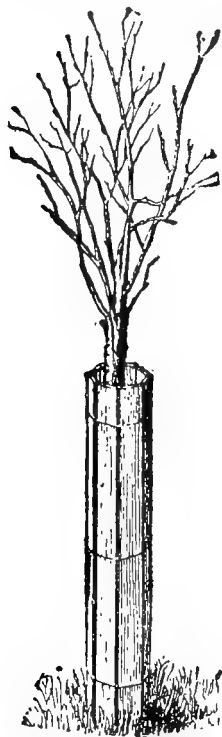

FIG. 59. — Trunk of apple tree inclosed in lath screen.

It appears to be due, in some cases, to the superheating of the cambium in summer — in others to a return of severe freezing weather after a period sufficiently warm to excite the cambium cells to activity. A preventive is to shade the trunk and larger branches by inclosing them with straw or similar material, or with a lath screen (Fig. 59).

186. Tip-burn of potatoes. —

Potato foliage is often injured by sun heat in summer, as is shown by the browning of the leaves from the tip and edges toward the center, or on the border of holes made by insects. This affection, known as tip-burn, is due to the destruction of protoplasm in the cells and is often mistaken for fungus work. It is most serious in dry seasons. No specific remedy for it is known, but it may be in part avoided by selecting varieties of potatoes least subject to it, and in part by such attention to soil and cultural practices as will tend to conserve the moisture during dry weather.

as will tend to conserve the moisture during dry weather.

THE PLANT AS AFFECTED BY EXCESSIVE COLD

187. Effect of cold. — The immediate effect of cooling the plant is to check the activity of its vital processes. When a certain degree of cold is reached, the protoplasm loses its power to imbibe water (62); hence the plant tissues become less turgid, and the foliage droops somewhat (102). With a sufficient reduction of temperature, ice crystals form within the tissues and the succulent parts of the plant assume a glassy appearance. The foliage of many plants, as celery, parsnip and the like, assumes an abnormal position when frozen.

188. Relation of water to freezing. — The more water plant tissues contain, the sooner they freeze. Since the water of plants is not pure, but is a solution of various substances, it does not freeze at the freezing point of pure water (32° F.), but at a lower temperature, determined by the degree of concentration of the solution, or the intimacy with which it is combined with the tissues of the plant. The more thoroughly dormant the condition of a plant, or part of a plant, the less water does it contain, and the better is it able to endure cold (174).

189. The power of plants to endure cold depends upon various conditions, aside from the amount of water contained, as

Heredity. — Plants by nature possess widely differing powers to endure cold. The *Anoetochilus* perishes when exposed for a considerable time to a temperature of 42° F., while other plants, as the common chickweed (*Stellaria media*), are uninjured by prolonged cold, far below the freezing point (175).

The rate of thawing of the frozen tissues. — The more slowly the thawing takes place, the less likely is the frozen

part to suffer injury. Many bulbs, tubers and roots which survive the severest winters within the soil, where they thaw slowly, are destroyed by moderate freezing if quickly thawed. Frost-bitten plants are seldom injured when sheltered from the morning sun by a dense fog, which causes them to thaw slowly. Apples, covered in the orchard in autumn by leaves, sometimes pass a severe winter with little harm.

When the water that is withdrawn from the tissues in the freezing process is gradually set free by slow thawing, it may be absorbed by them again and little or no harm results.

The length of time the tissues remain frozen. — A comparatively slight degree of frost, if prolonged, may act more injuriously than a severer degree of shorter duration. Prolonged freezing is especially injurious when the frozen parts are subjected to drying wind, which evaporates their water, while the frozen condition prevents movements of their fluids.

The frequency with which freezing and thawing are repeated. — Frequent slight freezing and thawing are far more injurious than a prolonged frozen condition, even though the latter occurs at a much lower temperature. Winter wheat and rye, and strawberry beds are often more damaged in mild winters, in which freezing and thawing weather alternate, than in more severe ones, when the temperature is mostly below freezing. The chief damage is usually done to these crops in late autumn and early spring.

The previous treatment of the plant. — Plants grown by artificial heat may be far less able to endure cold than others of the same varieties grown in the open air, possibly owing to the more succulent condition of the former.

Gardeners harden plants grown under glass, by gradually exposing them to the cooler out-door atmosphere, before removing them to the open ground.

The treatment of the frozen tissues. — Handling plants, fruits or vegetables while frozen greatly aggravates the damage from frost, probably because the handling increases laceration of the cells by the ice crystals within them.

190. Treatment of frost-injured plant tissues. — Frost-injured plants, fruits or roots may often be saved from serious damage, if promptly placed under conditions that cause the slowest possible thawing of the tissues, as shading from the sun's rays, immersing in ice water or covering with snow. They should be handled as little and as carefully as possible while frozen. Sprinkling with cold water is often sufficient to restore frost-bitten plants.

Aside from the death of tender plants by cold, more or less hardy species suffer injury in a variety of ways, of which the following are examples :

191. Destruction of terminal buds by cold. — In plants which do not mature their terminal buds in autumn, as the raspberry, sumac, grape and the like, destruction of the tips of growing shoots by frost is a regular occurrence in climates of severe winters. The distance which the shoots are killed back depends upon the succulency of the growth, the severity of the winter and the natural power of the plant to endure cold. Plants thus affected are not always to be regarded as tender, since they often grow wild in climates of very severe winters.

192. The darkening of the wood (black-heart) of certain trees, as the pear, in climates of severe winters, appears to be a chemical effect of the cold. It begins at the center of the stem and in extreme cases may extend

clear to the cambium, when the bark ceases to adhere, and the tree or branch thus affected dies. In stone fruits, this trouble is often accompanied by a flow of gum. If the coloring of the wood does not extend to the cambium, the tree or branch may survive, but the first season's growth thereafter is generally feeble and the fruit or the seed crop often fails. During the second season, healthy growth may be resumed, but the heart-wood is rarely or never restored to its normal color. Black-heart may result from other causes than cold.

Other chemical changes result from cold, as the sweetening of potato tubers when chilled, the removal of astringency from the wild grape and persimmon, and the heightening of the flavor of the parsnip.

193. Splitting of wood. — Tree trunks are often split open by severe freezing, the split or frost crack remaining open until the return of mild weather. This most often occurs in hard-wooded, deep-rooted deciduous trees, as the oak. Frost cracks are due to the fact that upon freezing the water is withdrawn from the walls of the cells and vessels of the woody tissues, in other words, they "freeze dry." This causes them to shrink and so crack open just as they "check" in ordinary drying. Frost cracks close in summer and as a rule heal by callus growth (72) pushing together from the two sides. Severe freezing may again tear this open the next winter. Such successive stimulations to callus growth often give rise to prominent ridges bordering the frost crack and known as frost ribs.

The splitting down of the main branches of certain varieties of the apple tree appears to be favored by the expansive force of ice in narrow crotches, which retain snow and water. Varieties the branches of which leave the trunk at a wide angle are not subject to this trouble.

194. Bark-bursting on the trunks of young apple trees often occurs when freezing weather overtakes late-growing and hence poorly-matured wood. In severe cases the bark splits longitudinally entirely through the cambium layer and from the ground to the lower branches; and the bark is loosened from the wood nearly or quite around the trunk. Such trees are practically ruined, but trees slightly injured by bark bursting may fully recover.

Bark-bursting is usually more severe on deep, rich, moist soil and in seasons that favor late growth, or in which freezing weather occurs unusually early. Late-growing varieties are most subject to it. Its occurrence is lessened by treatment that favors early maturity of the wood (199, 200).

195. Root-killing of trees. — When a very dry autumn passes to winter without rain or snow, the surface layers of the soil sometimes freeze so severely as to destroy the roots of trees. Root-killing is usually most serious on light soils, and on one-year-old, root-grafted (391) nursery trees (386). With very severe freezing on bare ground, root-killing sometimes occurs on soil well supplied with water. The destruction of the roots may be complete or only partial. In the latter case, the tree, if of a vigorous variety, may largely outgrow the trouble, though complete recovery is rare.

Treatment that prevents late growth (199, 200), or mulching the ground about trees tends to avert root-killing.

196. Killing of flower-buds. — Flower-buds are often destroyed by cold while other parts of the plant are uninjured. This frequently occurs in the peach, cherry, apricot, nectarine and certain species of the plum in climates of rather severe winters, especially after the buds have

been somewhat excited by unseasonable warm weather. Flower-buds thus destroyed are dark-colored at the center. Often only a part of the embryo flowers on a tree are destroyed.

197. Killing of flowers. — Flowers are especially sensitive to cold. Fruit crops are usually wholly or in part cut off if a slight frost occurs during bloom, and in certain fruits, as the apricot and some species of the plum, the blossoms sometimes appear to be destroyed by a degree of cold that does not descend to the freezing point, possibly through interference with pollination or pollen germination (150). When the freezing is accompanied with snow, however, open flowers may escape without harm, probably owing to the slow extraction of the frost (189).

198. Destruction by ice. — Low plants are often destroyed by ice, especially when the ice layer forms in direct contact with the soil about them and remains for a time after the return of warm weather. The same effect results sometimes from a covering of snow, of which the top has formed into a crust of ice. Winter grain, strawberry plants, lawn grass, alfalfa, and red clover are often smothered in this way. Surface drainage of ground devoted to such crops is highly important.

199. Heaving. — Frost may heave plants out of the ground so forcibly as to break or tear away the roots or else so loosen the roots from the soil that the plant perishes. This is especially likely to occur on heavy clay soils and with young plants having a tap-root, as red clover, or with bulbs when planted shallow and left without a mulch. Such heaving comes with alternate freezing and thawing, especially in the spring. It is due to the expansion of the surface layer of soil which by buckling upward lifts the plants just as it heaves fence posts out of the ground.

METHODS OF AVERTING INJURY BY COLD DURING THE
DORMANT PERIOD

200. Dry soil. — A dry soil favors wood maturity, while an abundant water supply retards it. Soil treatment that restricts the water supply toward the close of the growing period tends, therefore, to hasten wood maturity and thus to reduce damage from cold (174). Tillage should be early discontinued about trees liable to winter injury, and in wet seasons mulching should be removed. Oats, buckwheat or clover sown in the nursery or orchard in late summer promote wood maturity by increasing evaporation from the soil and are further useful as a covering to the ground in winter (195). Draining heavy or wet soils promotes wood maturity by promptly removing surplus water.

201. Pinching the terminal buds (416) a few weeks before the time for leaf fall favors wood maturity by checking growth, as does the removal of the younger leaves, in which food preparation is most active. These methods may be employed upon young trees — especially nursery trees, which are very liable to make late growth. Early gathering of the fruit from trees of late varieties also tends to hasten wood maturity.

202. Protection with non-conducting materials prevents damage from cold in many herbaceous and shrubby plants in climates where they are not fully hardy. By covering such plants with straw or other litter, or with soil, we lessen to some extent the intensity of the cold, but — more important — we prevent frequent freezing and thawing (189), and in a measure, the destructive heaving of the ground (198). A covering of straw, leaves or other litter is preferable for low, herbaceous plants, such as straw-

berries. The covering should not exceed an inch or two in thickness, otherwise the plants may be smothered in warm winter weather. For taller plants, such as the grape and raspberry, the soil is usually the most convenient and satisfactory covering, since a litter covering tends to attract mice, that often injure woody stems. To assist in bending down the stems, a little earth is usually removed at the base on the side toward which they are to be bent. Shrubs too large for bending down may be inclosed in straw or similar material.

203. Exposure. — A northerly exposure is generally least trying to plants in winter, because it is least subject to fluctuations in temperature. The influence of the sun is here less perceptible and snow remains longer than upon other exposures. The summit of a hill is usually less trying than a valley, because the cold air tends to seek the lower places, especially in still weather (209).

Wind breaks, *i.e.*, plantings of trees intended to break the force of prevailing winds, act beneficially in lessening damage from cold, in so far as they prevent snow from drifting off the soil and mitigate the effects of drying winds (189). They favor the formation of frost, however, by checking the air currents (210).

METHODS OF AVERTING INJURY FROM COLD IN THE GROWING PERIOD

204. The freezing point. — Plants are much more susceptible to injury from cold during their growth period than during their dormant period (170). Comparatively few plants, however, are injured by cold at any season until the temperature falls below the freezing point of water (32° F., 0° C.) or when so-called hoarfrost occurs.

It is this extreme that we have chiefly to fear and to guard against during the growing period.

205. The cause of hoarfrost. — A sponge saturated with water cannot be compressed in the least unless a part of the water escapes. If it is but half saturated, it may be compressed somewhat without any escape of the liquid, but if the compression passes a certain limit, the water will begin to escape.

The air is like a sponge in being capable of taking up a certain amount of water. But the amount of water the air can take up depends much upon its temperature, its capacity for water increasing as the temperature rises, and decreasing as it falls.

Suppose a given amount of air at a temperature of 50° F. has taken up all the water it can hold at that temperature. It is clear from what has just been said that if the temperature of this air is reduced, some of its water will be set free or precipitated. If the air were only half saturated at 50° F., its temperature could be reduced considerably before any of its water would be precipitated; but when a certain degree of cooling is reached, the air will no longer be able to hold all of its water, and a part will be precipitated. The cooling of the air corresponds to the compression of the sponge. The atmosphere always contains more or less water in the form of watery vapor, and the temperature at which the atmosphere on cooling begins to precipitate a part of its water is called the dew point. The temperature of the dew point depends, therefore, upon the amount of water the air contained. When the dew point is above the freezing point of water (32° F., 0° C.), the precipitation is in the form of dew or rain; but when it is below the freezing point of water, the precipitation is in the form of hoarfrost or snow.

206. Foretelling frost. — We know that sprinkling the floor of a room cools the air, even though the water used is no cooler than the air of the room. This is because the air in taking up watery vapor absorbs heat, but this heat is set free again when the watery vapor is precipitated. A steam radiator gives out heat because the steam within it is condensing into water. It follows that when the dew

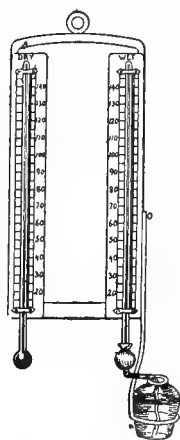

FIG. 60. — Sling psychrometer, used to foretell frost.

point of the atmosphere is reached, a very considerable amount of latent heat is given off, which checks the fall of temperature. The temperature of still air, therefore, rarely falls much below the dew point, and since the latter at any given temperature depends upon the amount of moisture in the air, if we have an instrument capable of indicating both the temperature and the moisture of the air, we may compute the lowest temperature to which the atmosphere will be likely to descend during any given night, and thus we may foretell frost with some degree of certainty.

207. The sling psychrometer enables us to determine both the temperature and the moisture of the air. This instrument consists of two accurately-graduated thermometers attached to a board or case (Fig. 60). The bulb of one thermometer is inclosed in thin muslin, which is wet just before using the instrument by dipping the bulb in rain water, or is connected with a small vessel containing rain water, as shown. By means of a string attached to the board or case at the end opposite the bulbs, the instrument

is whirled about in the air a few times, after which the thermometers are quickly read and the difference in the readings noted. When the air is comparatively dry, evaporation from the muslin proceeds rapidly, and on account of the heat absorbed, the wet bulb indicates a lower temperature than the dry one. When the air is damp, evaporation is slower, and the difference between the readings of the two thermometers is less. In saturated air, evaporation ceases and the two thermometers read alike. By means of the following table, the dew point for any ordinary out-door temperature and atmospheric humidity during the growing season may be readily determined.

208. Computing the dew point. — The wet-bulb depression is found by subtracting the wet-bulb reading from that of the dry-bulb; this is located in the top line of the table, and the dry-bulb reading is found in the left-hand vertical column. Opposite the dry-bulb reading, in the column headed with the number indicating the wet-bulb depression, is the dew point sought.

Opposite 47° , in the left-hand column, and under 7 in the top line, we find 28° — the dew point. If these readings are obtained toward sunset on a clear, still evening, we should expect frost, because the dew point is 4° below the freezing point of water. A slight wind, a hazy atmosphere, or a few fleecy clouds would render frost doubtful. With a dry-bulb reading of 45° and a dew point of 25° , a killing frost might be expected.

209. Use of weather maps in predicting frost. — The still, clear weather favorable to rapid cooling of the soil at night, to air drainage and frost is almost always due to a definite type of atmospheric circulation — the anticyclone. Anticyclones are of great extent, sometimes cov-

Example: Dry-bulb reading . . . 47°
 Wet-bulb reading . . . 40°
 Wet-bulb depression . . . 7°

TABLE FOR COMPUTING THE DEW POINT IN DEGREES FAHRENHEIT

DRY-BULB	WET-BULB DEPRESSION												
	1	2	3	4	5	6	7	8	9	10	11	12	13
35	33	30	28	25	22	18	14	8	+ 1	- 8	-28		
36	34	31	29	26	23	20	15	11	4	- 4	-19		
37	35	32	30	27	24	21	17	13	7	- 1	-12	-44	
38	36	33	31	28	26	23	19	14	9	+ 3	- 7	-25	
39	37	34	32	29	27	24	21	16	12	6	- 3	-16	
40	38	35	33	31	28	25	22	18	14	8	+ 1	-10	-35
41	39	37	34	32	29	26	23	20	16	11	4	- 5	-21
42	40	38	35	33	30	28	25	21	17	13	7	- 1	-13
43	41	39	36	34	31	29	26	23	19	15	10	+ 3	- 7
44	42	40	38	35	32	30	27	24	21	17	12	6	- 2
45	43	41	39	36	34	31	29	26	22	19	14	8	+ 2
46	44	42	40	37	35	32	30	27	24	20	16	11	5
47	45	43	41	39	36	34	31	28	25	22	18	13	8
48	46	44	42	40	37	35	32	30	27	23	20	15	10
49	47	45	43	41	39	36	34	31	28	25	21	17	13
50	48	46	44	42	40	37	35	32	29	27	23	19	15
51	49	47	45	43	41	39	36	34	31	28	25	21	17
52	50	48	46	44	42	40	37	35	32	29	26	23	19
53	51	49	47	45	43	41	39	36	34	31	28	24	21
54	52	50	49	47	44	42	40	38	35	32	29	26	23
55	53	52	50	48	46	43	41	39	36	34	31	28	24
56	54	53	51	49	47	45	43	40	38	35	32	29	26
57	55	54	52	50	48	46	44	42	39	36	34	31	28
58	56	55	53	51	49	47	45	43	40	38	35	32	29
59	57	56	54	52	50	48	46	44	42	39	37	34	31

ering half a continent, the atmospheric pressure at the center is high, whence they are also called "highs," the weather is clear, and the wind is calm or light in the center, and flows slowly outward in a clockwise spiral in the outer zones of the anticyclone. The temperature of the clear central area is lower than that of surrounding districts, even lower than those to the north, because of the free radiation of heat from the earth through the clear air, while the cloudiness of the surrounding districts has diminished the night fall of temperature.

Anticyclones move eastward or southeastward from western Canada, sometimes slowly, sometimes rapidly, at a rate averaging 26 miles an hour. They are shown, with their attendant temperatures, on the weather maps issued by the offices of the United States Weather Bureau. Their approach can be observed and their central temperatures studied a day or two before the psychrometric method described above can be applied at all. The weather maps and forecasts are sent free only for public display or distribution, but every farmer should arrange to have access to them at the postoffice, store, warehouse, creamery or on the rural mail carrier's wagon where they are posted every day during seasons when frosts are likely to occur.

210. Cold-air drainage. — Warm air, being lighter than cold air, tends to rise, while the colder air tends to fall. In a still atmosphere, therefore, the cold air accumulates in the lowest places. This explains the familiar fact that hollows and valleys are colder in still weather than ridges and mountains. In a falling temperature and in the absence of wind, gentle currents of the colder air tend to follow the water courses, which explains in part why frost so often "goes in streaks."

211. Factors tending to avert frost. — Wind tends to avert frost because it prevents the settling of the colder air and thus keeps the temperature of the lower strata of the atmosphere nearly uniform.

Clouds, haze and smoke tend to avert frost because they act to some extent like a blanket in preventing the radiation of heat from the earth, and thus check the fall in temperature (216).

212. Influence of a body of water. — The proximity of a body of water tends to avert frost because the water cools slower than the air and thus checks the fall in temperature of the atmosphere in the vicinity; also because it keeps the neighboring atmosphere moist, thereby raising the temperature of its dew point (205). The proximity of buildings and trees tends to avert frost, probably because these objects give up their heat gradually and thus temper the surrounding atmosphere.

213. Localities subject to frosts. — The localities most subject to untimely frosts are narrow and deep valleys inclosed on all sides, and inclined valleys that serve as channels through which cold air flows to lower levels. Partially-cleared districts usually suffer more from frosts than those fully cleared, because the remaining forests obstruct air drainage.

Marsh areas are subject to frost, because, in addition to their low situation as compared with the surrounding land, their luxuriant vegetation tends to cool the atmosphere in the vicinity by exposing a large radiating surface and promoting abundant evaporation.

Valleys surrounding elevated lakes that have an outlet through which the colder air may flow to lower regions are particularly free from damaging frosts. The valley of Keuka Lake, in west-central New York, so famous for its vineyards, is of this class.

214. Thermal belts. — In some elevated districts of mountainous regions, localities of greater or less extent are found in which damaging frosts are almost unknown. These have been called thermal belts, and their freedom from frost is explained by the merging of the warm air, that rises somewhat rarefied by heat from the lower valleys, with the atmosphere of the more elevated region that is rarefied to an equal extent by the high altitude. Thus the warm air ceases to rise, but lends its heat to temper the climate of the adjacent mountains.

215. Liability to frost. — Liability to damaging frost depends comparatively little upon latitude. Within the tropics are areas where frost is unknown because the temperature never falls to the freezing point. But in localities subject to frost, the liability of damage to vegetation from this cause is governed more by cold-air drainage (209) and proximity to water than by latitude. It is as important to select locations for peach growing with reference to spring frosts in the Carolinas as in the peach belt of Michigan, and favorable locations for the apple in Wisconsin sometimes escape damage from spring frosts in seasons when the apple crop is cut off by frost from extensive regions of the southern states.

216. Methods of preventing injury by frost. — Any non-conducting material lying between the earth and space, whether spread directly upon the earth or at a considerable height above it, acts as a blanket to intercept the radiating heat, and thus prevents in a measure the cooling of objects beneath it. For this reason, straw, muslin or other non-conducting material, spread over plants, usually protect them from frost.

While it is easy to protect a few plants from frost by covering them directly, it is much more difficult to protect

large plantations in this manner. Considerable plantings of the strawberry have been successfully protected from frost by covering the rows in the evening with straw or marsh hay, and where these materials are convenient, the work may often be cheaply and quickly performed.

Sometimes small plants standing in well-separated rows, such as potatoes, may be saved from frost injury by so running a plow between the rows that the plants are covered. The soil should be removed by the drag or otherwise as soon as safe.

The use of numerous small fires of oil or other combustible material to raise the temperature above the frost point has been recently adopted by western fruit-growers as a means of averting frosts.

CHAPTER IX

THE PLANT AS AFFECTED BY WATER

THE water supply dissolves the food materials in the soil; water is itself used in the growth of the plant; it modifies atmospheric and soil conditions. Its relation to plant culture is therefore very important.

217. Destruction of roots. — Excessive water in the soil destroys the roots of plants. We saw that oxygen is necessary to the life of roots (89). When the soil cavities are filled with water, the roots are soon deprived of oxygen, because the little oxygen contained in the water is soon exhausted (93). Smothering and decay of the roots follow. Seeds planted under such conditions usually fail. The soil water that is most useful to land plants is that which remains attached to the soil particles after percolation has nearly ceased (capillary water). Such water is well aërated because it is interspersed with cavities that are filled with air (91).

In the open ground the remedy for excessive soil water may usually be found in underground drainage. But the same trouble often occurs in potted plants, as the result of too compact soil or too copious watering. The expert recognizes this condition by a sour odor of the soil, by lifting the pot, or by tapping the pot with his knuckle. If the soil is soggy, the weight will betray the fact, or the

sound given out by the pot will be that of a compact mass instead of a more or less hollow body, as is the case with a pot of well-aërated soil. To remedy the evil, repot the plant in fresh soil of a proper condition of moisture, providing abundant drainage at the bottom of the pot (412).

218. Injudicious watering is perhaps the most common cause of failure in growing potted plants. The amateur too often assumes that the chief need of the plants is frequent watering, and so gives water in spoonful doses as the surface soil of the pot appears dry, without observing the state of the soil beneath. The roots of the plants in the meantime may be smothering in waterlogged soil or starving from drought. If, owing to inexperience, the condition of the soil cannot be determined by the means above noted, the soil may be tipped out upon the hand without materially disturbing the roots of the plant, by reversing the pot and gently striking its rim on the edge of the bench or table. The real condition can then be readily determined.

219. Watering. — Copious waterings at considerable intervals are preferable to frequent slight waterings. It should never be forgotten that air is as essential as water to the well-being of roots (89), and that the soil, however porous, requires occasional ventilation (93). A considerable quantity of water poured upon the surface soil of a potted plant, in passing downward not only thoroughly moistens the soil particles, but acts like a piston, forcing the vitiated air of the soil cavities ahead of it and out through the drainage hole at the bottom of the pot, while fresh air enters from above as the surplus water passes out beneath. Manure water should not often be used, as there is danger in giving the plant too much food.

220. Rapidly-growing plants require more water and are less liable to suffer from over-watering than slower-growing ones. During the rest period (172), plants should be given very little water.

221. Water requirement of plants. — Some species require more water than others. The native habitat of the plant is a partial guide to the amount of water needed. Plants native to arid regions, as the cacti and those from treeless, rocky locations, require little water and are readily destroyed by over-watering. “Plants with narrow and tough leaves, especially when the leaf-blade is vertically placed, do not, as a rule, like much water; plants with broad, leathery leaves prefer a damp atmosphere to great moisture at the roots. Succulent plants with hard epidermal cells (leafless Euphorbias, succulent Composites, Aloes and Agaves), and thin-leaved plants with a strong woolly covering of hairs are further examples of plants which require very little water.”¹

222. Dropsical condition. — Excessive watering sometimes produces a dropsical condition (œdema) in the leaves of plants under glass. This is most likely to occur in winter, when sunlight is deficient, especially if the soil is kept nearly or quite as warm as the air. Water accumulates in the cells, abnormally distending their walls — sometimes even to bursting. An unnatural curling of the leaves, with yellow spots and small wart-like excrescences on their surfaces, are some of the symptoms of this trouble. Less water, increased light and reduced bottom heat (362) furnish the remedy.

Frenching, a disease that often attacks growing tobacco on excessively-wet clay soils, may be caused by undue absorption of water by the roots. The leaves of affected

¹ Sorauer, “Physiology of Plants,” p. 207.

plants grow narrow, and are thick, fleshy and wrinkled. If the plants are pulled sufficiently to break the tap-root, before the disease has progressed too far, they often recover.

223. Water-sprouts (sap-sprouts, gormands) on fruit-trees are sometimes due to an excess of water in the soil. These thick, rapidly-growing shoots, with remote leaves and poorly-developed buds, growing from the main branches of unthrifty fruit-trees, are most common on undrained, heavy soils. They rarely produce much fruit, but tend to rob the bearing branches of light and nourishment. They usually continue to grow late, and in severe winters are often injured by cold. Water-sprouts may also result from over-pruning and from injury of the tree by cold, but in the absence of these conditions they suggest the need of drainage.

224. Cracking. — Fruits and vegetables often crack from excessive moisture, either through too much absorption by the roots or by direct absorption through the skin. Cracking is most frequent after heavy rains following drought. Apples, tomatoes, melons, carrots, kohlrabi, cabbage and potato tubers are subject to it. On wet soils, drainage may largely remedy the evil. The selection of varieties least subject to cracking is also helpful, especially in melons and tomatoes which often crack in comparatively dry weather. In these cases the cracking is probably due to an unequal maturing of the fruit, which causes certain parts to grow faster than others. The bursting of cabbage heads is due to the excessive absorption of water by the roots. To prevent it, we start the plants by pulling on the stem sufficiently to break a part of the roots.

225. Knobby potatoes are caused by a wet period

following a drought during the ripening season. Parts of the tuber that are still capable of growth, stimulated by abundant water, resume such activity. But since cell division is possible only in the parts containing protoplasm, the mature cells of the tuber can no longer divide, hence growth is limited to the younger parts, *i.e.*, the vicinity of the buds (eyes), and these therefore grow out into unshapely protuberances. The knob consumes a part of the starch previously stored in the tuber from which it grows, hence knobby potatoes are poorer in food value than smooth ones of the same lot.

Certain varieties of the potato are more disposed to knobiness than others. In varieties normally free from it, the planting of knobby seed tubers probably does not tend to increase the inclination to knobiness.

226. Air moisture. — Excessive moisture in the air is injurious to plants, since it tends to hinder normal transpiration (74) and favors the growth of certain fungous parasites (321). In the greenhouse, we control the atmospheric moisture by ventilation and care in the use of water. Out-of-doors, we guard against excessive moisture in the air by giving plants sufficient room to favor the circulation of air between them. The latter precaution is important in orchard planting, since several diseases that prey upon fruit-trees, as the apple scab (328) and pear blight (323), flourish in a damp atmosphere.

THE PLANT AS AFFECTED BY INSUFFICIENT WATER

227. Excessive transpiration. — Insufficient moisture in the air causes excessive transpiration (74), which reduces the tension of the cell-walls and thus retards growth (62). It also tends to clog the leaves with useless mineral

matters, causing their premature death (125), and favors the development of certain fungous parasites. The effects of insufficient moisture in the air are often very noticeable upon plants kept in living-rooms in winter. Such plants, especially when few in number, rarely make satisfactory growth and the lower leaves continually perish. Moistening the air by evaporating water in the room, or setting the pots containing the plants upon a table covered with moist sand usually remedies the trouble.

Insufficient moisture in the open air rarely occurs unless there is also a dearth of water in the soil.

228. Retarding growth. — Insufficient moisture in the soil retards growth both by reducing the tension of the cell-walls (62), and by lessening the supply of food from the soil. The tendency of drought is, therefore, to starve the plant.

Plants that have been subject to insufficient water from the beginning usually suffer less from drought than those previously well watered, because their root system has become more extensively developed (111).

229. Hastening maturity. — Drought tends to hasten maturity, especially in annual plants, since it favors flowering (134). Lettuce, spinach, rhubarb and the like "run to seed" earlier if insufficiently supplied with water. Potatoes usually ripen earlier in dry seasons than in wet ones. If the drought is sufficiently severe or sufficiently prolonged, diminution or failure of seedage results.

230. Toughness of plant tissues results from drought. The crispness and tenderness that give quality to salad vegetables, as celery, lettuce, radish and the like, due to a distended condition of their cell-walls, is largely

wanting when the water supply during growth has been insufficient.

Insufficient water during growth injures the quality of tobacco. Leaves thus affected have a peculiar spotted appearance when cured, and do not "sweat" properly.

231. Cultivation of the soil. — Crumbling of the surface soil tends to prevent drought, since it greatly lessens the points of contact in the soil particles, and thus interferes with the rise of the soil water by capillary attraction to the surface where evaporation chiefly occurs. An air-dry surface layer of crumbled soil also tends to prevent evaporation by keeping the soil cooler beneath. A puddled crust on the surface of the soil, as is formed by rain on soils containing clay, tends, on the other hand, to restore capillary action and thus to promote evaporation. Some gardeners cultivate their hoed crops as soon as possible after rains for the main purpose of breaking this crust and thus stopping the capillary action.

Cultivation is also beneficial by aerating the soil (93).

The roots of plants should never be forgotten nor ignored in cultivating crops (109).

232. Mulching tends to prevent drought, by interposing a layer of poor-conducting material between the ground and the sun's rays. This keeps the surface soil cooler and so checks evaporation.

The best mulching material is the one that conducts both heat and moisture slowest. Straw, marsh hay, leaves, manure, shavings, sawdust, spent tan and sand are all useful for mulching, but the first four named are generally preferable to the others, especially if free from weed seeds.

Growing plants tend to dry the soil because the root-hairs continually draw in soil water and force it into the

leaves (101) where it passes off by transpiration (74). Weeds, therefore, rob crops of moisture (336).

233. Irrigation, *i.e.*, the extensive watering of out-door plants, is the final remedy for drought. It is necessary to plant culture in arid regions, and may be profitably employed at certain times in the great majority of seasons in many localities where the annual rainfall would satisfy the needs of crops, were it more uniformly distributed.

234. Drying beyond a certain limit kills plant tissues by destroying in part their power for conducting water. Care should be used to retain the normal moisture in buds (394), cuttings (358) and cions (386) and in the roots of plants lifted for transplanting.

CHAPTER X

THE PLANT AS AFFECTED BY UNFAVORABLE LIGHT AND WIND

PLANTS cannot grow or subsist in darkness. The degree of light affects them strongly. Winds increase transpiration if they are dry; and they affect plants in other ways. These subjects now need our attention.

EXCESSIVE LIGHT

235. Shading plants. — The unobstructed rays of the sun are often injurious to young seedlings, to unrooted cuttings and to plants recently transplanted. It is difficult to separate the influences of light and heat, since the heat is usually greatest where the sun's rays are brightest; but bright light probably stimulates transpiration (74) independent of heat and thus tends to exhaust the plant of water. Various devices are used to break the force of the solar rays. In out-door culture,

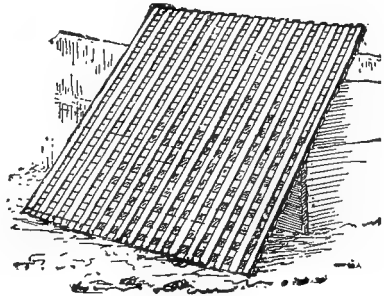

FIG. 61. — Lath screen used for shading coldframes and tender plants in the open ground.

screens of lath (Figs. 61, 62), cloth or brush (Fig. 63) are often placed over beds containing cuttings or tender seedlings, as of many cone-bearing trees. Cuttings in the nursery may be shaded by supporting a board over the row, on short stakes (Fig. 64), so as to protect them

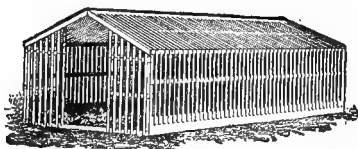

FIG. 62. — Shed screen built of three-inch-wide slats, for shading tender plants and for storing pots and boxes of slow-germinating seeds.

during the warmer hours of the day. Shingles, flower-pots or large green leaves, as of the burdock, are useful for shading plants of the cabbage, tomato and the like.

In culture under glass, the glass is often thinly washed with lime or clay to render it partially opaque, or lath screens are used either above or below the glass. On greenhouse benches, sheets of thin paper or light cloth screens are useful for shading cuttings, recently-planted seedlings and germinating seeds.

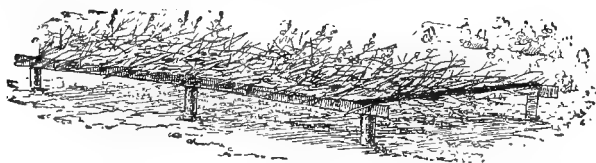

FIG. 63. — Brush screen, for shading tender plants in the open ground.

Shading should never be so put on as to prevent a free circulation of air about the plants.

A shade that obstructs only a part of the rays of sunlight at a time, as does the lath or brush screen, is generally preferable to one that continuously breaks the force of all the rays, as does paper or whitewashed glass.

236. Cauliflower heads should be sheltered from sunlight to prevent the formation of chlorophyll in their cells (59), which darkens their color and gives them a strong flavor. The leaves surrounding the head may be tied about it or broken over so as to shade it from di-

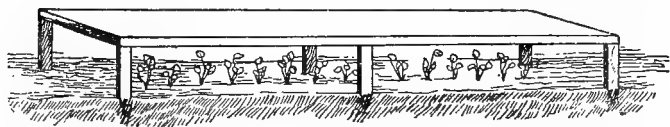

FIG. 64. — Board shade for recently-set plants, or for cuttings not yet rooted.

rect sunlight. Burst cabbage heads should be cut at once to avoid the formation of chlorophyll within them.

PLANTS AS AFFECTED BY INSUFFICIENT LIGHT

237. Abnormal development. — Insufficient light is a frequent cause of abnormal development in plants. Some of its effects are: Excessive elongation of the cells of the internodes (75), causing the plants to “draw up” or grow spindling; deficient formation of chlorophyll (59), giving the foliage a pale-green, yellowish or whitish tint, and resulting in lessened food formation, causing reduced leaf development and deficient vascular bundles (67); reduced transpiration tending to watery, weak-celled growth; weakening of the color and flavor of some fruits, as the apple and strawberry; preventing pollination (150); reducing fruitfulness.

Owing to these causes, plants grown in deficient light have tall, slender, weak stems; few, small, pale leaves and scanty roots and are often unfruitful. Tomato

plants grown in winter on poorly-lighted benches are often unfruitful even when they grow well and bloom freely. Such plants, though of species that normally grow upright, are often unable to stand erect without support. Familiar examples are cabbage and tomato plants that lop over when planted out, because grown in the seed-box to transplanting size without "pricking off" (105); and grain sown too thickly on rich ground, that falls (lodges) before maturity.

238. Close planting. — Too close planting causes deficient light and all the resulting evils. Indian corn grown too thickly does not ear well and is lacking in nutritive qualities; strawberry plants grown too closely do not fruit well and the fruit lacks flavor and firmness; nursery trees grown too closely are slender-stemmed, deficient in foliage and have poorly developed roots. A rule to govern distance in planting has already been given (122).

When a slender and flexible growth is desired, as in trees grown for hoop poles, or willows for wicker-work and tying, a certain amount of crowding is advisable.

239. Weeds cause deficient light in low-growing crops, such as strawberries, dwarf beans, potatoes and the like, and also tend to rob the plants of food and moisture. They are, therefore, decidedly injurious (336).

240. Plants under glass are especially liable to suffer from deficient light, because the walls and sash-bars of the structure necessarily intercept a considerable part of the solar rays. The roofs of glass-houses should be formed of large lights of glass, with the smallest possible sash-bars, and the benches should be arranged to bring the plants as near to the glass as possible.

Plants having their leaves densely covered with hairs generally require a large amount of light.

241. The electric light has been found useful as a supplement to the scanty sunlight of short, early-winter days, in forcing certain vegetables and flowers.

242. Insufficient pruning prevents the formation of fruit-buds in orchard trees by restricting light and thus reducing food formation (58). Compare Fig. 65, which shows a fruit branch of the apple tree grown where exposed to abundant sunlight, with Fig. 66, showing one grown in partial shade.¹

243. Blanching of certain vegetables, such as celery, endive, cardoon and sea kale, is practiced by gardeners to render them more tender and delicate. It is effected by excluding the light from the parts desired for use, until the chlorophyll (57) mostly disappears, by banking the plants with earth or inclosing them in paper or in drain-tile. Very close planting is sometimes practiced to promote blanching.

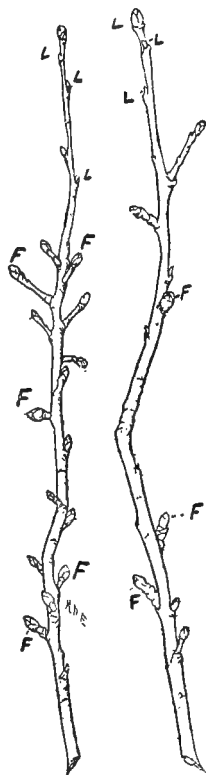

FIG. 65. FIG. 66.

FIG. 65.—Fruit branch of apple grown in abundant light.

FIG. 66.—Another grown in partial shade.
F, fruit-buds; L, leaf-buds.

PLANTS AS AFFECTED BY EXCESSIVE WIND

244. Preventive measures.—Damage to trees and other plants by excessive wind is too familiar to need notice, except to suggest preventive measures.

¹ See Bulletin No. 37, R. I. Agri. Exp. Sta.

The premature blowing off of fruits may be in a measure prevented by planting fruit trees where they are more or less sheltered from prevailing winds by shade trees, buildings, forests or elevations of land. Orchards may be in part protected by planting a windbreak on the windward side (203).

Shade trees in exposed situations should be headed low, and the head should be formed of numerous branches. The higher the head, the more it is exposed to wind and the greater is the leverage upon the trunk. Several small branches are better able to bear the tempest than a few larger ones.

Shade trees for exposed situations should be of species not likely to be deformed by wind. Certain trees, as the white maple (*Acer saccharinum*), often develop one-sided if planted where exposed to prevailing winds, while others, as the sugar maple (*Acer saccharum*) and Norway maple (*Acer platanoides*), are not thus affected.

PLANTS AS AFFECTED BY INSUFFICIENT WIND

245. Fungous attacks. — Insufficient wind promotes the development of certain fungus parasites (321) by favoring an excessively moist atmosphere. Orchards too closely planted or surrounded by wind barriers suffer more from fungus attacks than those having freer circulation of air between the trees.

246. Frost damage. — Insufficient wind promotes damage from frost by permitting cold air to settle in the lower places (209). On these accounts, gardens and fruit plantations should not be entirely surrounded by wind barriers.

247. Pollination (150) is dependent upon wind in many plants, as the coniferous trees, oaks, elms, birches, corn and sedges; but as the pollen of such plants is very light, their fruitfulness is not often much restricted by insufficient wind.

CHAPTER XI

THE PLANT AS AFFECTED BY UNFAVORABLE FOOD SUPPLY

WE saw that water is the most important constituent of plant-food (62) and we have already considered the plant as affected by water supply. But a proper supply of the other essential food constituents is only second in importance to that of water.

EXCESSIVE FOOD

248. Excess of most foods. — Excessive food is not the extreme that we have most to fear, since natural soils are rarely excessively fertile, and we can make them so only by costly methods. Indeed, nearly all of the constituents of plant-food may be present in excess of the requirements of plants without working harm. Nitrogen, however, which aside from water is the most potent food constituent, must be used with some discretion.

249. Excessive nitrogen stimulates growth at the expense of flowers, seed and fruit. In crops grown for these parts, therefore, fertilizers rich in nitrogen must be used with caution. Apple, pear and quince orchards liberally manured with such fertilizers produce an excessive, over-succulent growth of the wood, that is subject to blight and winter injury and forms comparatively few fruit buds. Grain under similar conditions forms

long, weak straw, with poorly-filled heads. Grape vines on over-manured ground produce excessive wood with few and late-ripening bunches.

There is little danger of over-manuring, however, with crops grown for parts other than flowers, fruit or seed, so long as decomposed stable manure is used (251). But the more concentrated animal manures, as those from poultry and the hog, the chemical compounds of nitrogen, as nitrate of soda and sulfate of ammonia (261), and the so-called "high-grade" commercial fertilizers must be used with caution, as they may destroy the plants if applied in excess.

PLANTS AS AFFECTED BY INSUFFICIENT FOOD

250. Lack of food and water. — It is difficult to separate the effects of a lack of food from those of a lack of water, since the food is mainly conveyed to the plant in the soil water (62). But even with a proper water supply, if one or more of the required food materials is lacking (60), a normal plant structure cannot be built up. An excess of one food substance cannot compensate for the lack of another, except in a few instances.

251. Dwarfing of plants. — Insufficient food dwarfs the plant in all its parts. A dwarfing of the size of the plant body may occur, however, without a corresponding dwarfing of the seed product; hence plants may often bear their maximum amount of seed or fruit without attaining their maximum dimensions. Plants grown for seed or fruit are, therefore, less likely to be restricted in yield by insufficient food than those grown for their leaves, stems, roots or tubers. The cereals, for example, produce well on land not sufficiently fertile to yield equally

good crops of tobacco, cabbage, celery, lettuce or potatoes. But with a sufficient restriction of food, the seed product will suffer diminution or be wholly cut off.

252. Reducing plant-food. — Crop-growing tends to reduce plant-food in the soil in proportion as the fertilizing components of the crops are removed from the land and are not returned to it, directly or in equivalent. Fortunately, considerable plant-food is constantly being liberated by the disintegration and decay of rock or soil materials, or is being deposited from the atmosphere in rain or snow, so that it is impossible to exhaust the soil of plant-food, even with the most improvident culture. But the cultivator should aim at the largest returns from his soil, and these are impossible without restoring certain materials that continued crop-removal invariably reduces below the limit of profitable yields.

253. Deficient food elements. — The food elements most likely to be deficient, when plants are properly supplied with water, are nitrogen, phosphorus and potassium. These are all liberated in greater or less quantities, when vegetable or animal material (organic matter) decays in the soil; hence all such material has more or less value as fertilizers. But we need not wholly depend upon refuse organic matter for fertilizers, since the leguminous plants add nitrogen to the soil (259), and compounds of nitrogen, phosphorus and potassium may often be purchased in artificial fertilizers at prices that place them within the reach of the cultivator.

254. Importance of nitrogen. — Nitrogen is the most important fertilizing element because it is liberated in smallest amount by rock decay and is most expensive in the market. Nitrogen is chiefly used by plants in the form of nitrates, *i.e.*, in combination with certain other

substances, as soda, potash, lime, magnesia and iron. Ammonia, which is a gaseous compound of nitrogen and hydrogen, is also used to some extent by plants. Free nitrogen, the most abundant constituent of the air, plays no direct part in plant nutrition (259).

255. The sources of nitrates in the soil are :

(a) Nitrification, by which the nitrogen contained by organic matter and ammonium sulfate in the soil is changed to nitric acid through the agency of microscopic plants (bacteria). The nitric acid thus formed combines with certain substances (bases) in the soil, as potash and lime, forming nitrates (254); (b) symbiosis on the roots of leguminous crops, through which atmospheric nitrogen is changed to nitric acid (259, 112); (c) deposits from the atmosphere in rain or snow (260); (d) ammonium salts or nitrates applied to the soil (261).

256. The conditions affecting nitrification are similar to those affecting plant life in general, since nitrification results from plant life. As it takes place below the surface of the soil, it is favored by the same conditions that favor the root growth of land plants, viz., aëration, warmth and moisture. In general, it is active during the growing season, but at a standstill during the dormant period. It does not proceed rapidly in spring until the soil has become sufficiently warm to promote active root growth.

Nitrification also releases the other food materials contained by organic matter (92).

257. Soil aëration promotes fertility by favoring nitrification. Thus cultivation and drainage (of heavy soils) not only directly promote the growth of plants by assisting aëration (93), but they actually increase plant-food. Early plowing in spring promotes nitrifi-

cation by favoring warming of the soil. Cultivation in dry weather further promotes plant nutrition by preventing the accumulation of soluble plant-food in the dry surface soil, where it is deposited above the reach of roots through evaporation.

258. Partially-decomposed organic manures act more promptly than fresh ones, because nitrification has already begun in these materials.

259. Value of legumes.—Leguminous plants enrich the soil with nitric acid (255), which is formed from atmospheric nitrogen in the tubercles on their roots through the agency of microscopic plants (112). Even when a part of these crops is removed from the land, as when clover is harvested for hay or peas for their seed, the land is richer in nitrogen than before the crop was planted. The principal leguminous crops are the clovers, peas, beans, lentils, sanfoin, vetches, alfalfa, lupine and certain species of *Lathyrus*. Highly valuable as are these crops for the nitrogen they leave in the soil, it should be remembered that they do not contribute phosphoric acid or potash, and hence must not be wholly depended upon for soil fertility (262, 263).

Leguminous plants are supplied with nitrogen by the micro-organisms in their roots (112), and hence do not require this element in fertilizers.

260. Value of rain and snow.—Rain and snow add nitrogen to the soil in small quantities, both as nitric acid and ammonia, which they have taken from the air, but the amounts thus added, while useful to plants, are not under our control.

261. Nitrogen may be purchased for fertilizing purposes as sodium nitrate (nitrate of soda, Chili-saltpeter), ammonium sulfate (sulfate of ammonia) and in organic

materials. The former is available as plant-food when dissolved in the soil water. It is best applied immediately before the planting of a crop or in small quantities at intervals during growth, since it is in danger of being washed out of the soil in drainage water. Sodium nitrate is especially useful for garden crops started early in the spring, when the soil is too cool for active nitrification (255). The surface soil is apt to be poor in nitrates in spring, because they are often washed down by the autumn and winter rains.

Ammonium sulfate is changed to nitrates in the soil before it is used by plants, and hence is less prompt in its action than sodium nitrate. It is more tenaciously held by the soil than sodium nitrate and is therefore less likely to be lost by washing.

262. Phosphorus is used by plants in the form of soluble phosphoric acid, which exists in the soil in combination with lime, iron and alumina, as phosphates of these substances. It may be purchased in the form of mineral phosphate of lime, ground bone, wood ashes, odorless phosphates, and the like. The first two are insoluble in water unless treated with a strong acid, when they are known as acid phosphate or superphosphate. Phosphoric acid is not readily washed out of the soil, even in its soluble form.

263. Potassium is used by plants in the form of potash, *i.e.*, potassium combined with oxygen. Potash exists in the soil mainly in combination with chlorin (chlorid or muriate of potash), with sulfuric acid (sulfate of potash), or with nitric acid (nitrate of potash). All these forms of potash are freely soluble in water and are immediately available as plant food. Nitrate of potash (saltpeter) is a most valuable fertilizing material, since

it contains both potash and nitrogen, but unfortunately its price is too high to permit of its use for this purpose. The muriate, either pure or in crude form (kainit), and sulfate may, on the other hand, be purchased at reasonable prices. The sulfate is considered preferable for tobacco and potatoes as it is thought to produce a better quality of product. The muriate acts more promptly than the sulfate, however.

264. Wood ashes are a valuable fertilizer, especially when unleached, as they contain both potash and phosphoric acid. In leaching, the potash is mostly washed out, but the phosphoric acid is largely retained. Ashes contain no nitrogen.

265. Nitrogenous fertilizers. — Farm and stable manures should be the first dependence of the cultivator. Aside from these, leguminous crops (259) are undoubtedly the cheapest source of nitrogen for the farm, and with unleached wood ashes furnish all the needed fertilizing ingredients for grain crops grown in rotation. For garden crops, however, if sufficient stable manure cannot be obtained, more nitrogen may often be profitably used than can be furnished by leguminous crops, hence for these, commercial fertilizers may often be added with advantage.

266. Signs of lack of food. — Crops suggest their own needs to some extent, so long as they are not suffering from drought. As a rule, a lack of nitrogen is indicated by pale-green foliage or small growth of leaf or stalk. Excess of nitrogen is indicated by very large growth of leaf or stalk, with imperfect bud-, flower- and fruit-development. Lack of phosphoric acid is indicated by scanty crops of light or shrunken seeds on plants of normal size. Lack of potash is indicated by small crops of inferior fruit, accompanied by satisfactory growth.

267. Crop rotation economizes plant-food, because some crops use more of a given food constituent than others. The alternating of crops having different food requirements tends to prevent the exhaustion of special food substances. Crop rotation also aids in avoiding damage from injurious insects and fungi.

268. A growing crop tends to conserve fertility, because it reduces drainage by taking up water from the soil, and at the same time appropriates the available plant-food, thus preventing loss of the latter from leaching.

269. Manures are, in part, the raw material from which the cultivator turns out valuable products. They should, therefore, be most carefully preserved and applied. Leaching of the manure pile by undue exposure to rain and over-rapid fermentation, by which nitrogen escapes as ammonia or other gaseous nitrogen compounds, should be stringently avoided. All refuse organic matter should, so far as possible, be made to increase the always too small stock of manure.

CHAPTER XII

PLANTS AS AFFECTED BY ANIMAL PARASITES

THE only instance of a beneficial plant parasite (24) of special interest to the cultivator is the micro-organisms in the roots of leguminous plants, which we have already considered (259). Many parasites of harmful insects are beneficial, but these are beyond our scope. We need, therefore, to treat here only those parasites that are directly injurious to economic plants.

270. Classes of parasites. — The injurious parasites of plants are very numerous and a scientific classification of them is beyond the limits of this work. We shall only endeavor to arrange the different parasites into groups based on their manner of working injury and the methods by which they may be controlled.

With reference to the character of their injury and the preventives used, as well as in their natural characteristics, plant parasites are readily separable into two great classes, viz., animal and vegetable parasites.

The four-footed animals that injure cultivated crops nearly all belong to the class known as rodents, which include mice, gophers, rabbits, woodchucks, moles and so on. These may usually be controlled by trapping, shooting or poisoning, or by protecting the plants.

Since worms, slugs and snails work the same kind of

injuries as some insects and are controllable by the same methods, we do not distinguish between them in the following paragraphs.

271. Mice. — Damage from mice to orchard and nursery trees is very common. Mice are usually more troublesome on sod ground covered with snow, especially beneath snow banks, hence all grass should be removed in autumn from the immediate vicinity of the trees. It is well to ridge the soil a little, at the base of the trees, so that the mice in burrowing beneath the snow will not be likely to come in contact with the stems. Packing the snow immediately about the trees is helpful in preventing damage in winter. The stems of orchard trees may also be wrapped in heavy paper or inclosed in fine wire netting or other protective material. If tarred paper is used, it should be promptly removed in spring, or it may cause injury to the bark.

Stored seeds of almost all kinds must be carefully guarded against mice.

272. Gophers are often troublesome by eating planted seeds and by burrowing about the roots of young orchard trees. They may be poisoned by placing corn, soaked in a weak solution of strychnine in water, about their holes.

273. Rabbits are especially troublesome to nursery trees, when the ground is covered with snow. The most satisfactory protection is to inclose the nursery with a fence of poultry netting, which should be banked up a little at the bottom to prevent the rabbits from passing under. It should be high enough to reach above the surface of the deepest snow.

Orchard trees may be protected against rabbits by inclosing the trunks with the devices mentioned under

sun-scald (185). Smearing the stems with blood has also been recommended.

274. Woodchucks are often troublesome to growing crops, but as they are seldom numerous, shooting or trapping generally suffices to prevent serious damage. Moles are very troublesome in some localities by eating the roots of plants. They may be largely controlled by the use of mole-traps. Pouring a little carbon bisulfid into their holes is also generally effective.

275. Birds are often troublesome by eating unharvested fruits and seeds. Inclosing the trees or plants



FIG. 67. — Screen-covered frame, for protecting hills of the melon and cucumber.

with fish netting, when this is practicable, is perhaps the most satisfactory preventive. The netting is not expensive, and the same piece may be used several seasons.

276. Useful insects. — Many insects are beneficial by destroying harmful insects or by promoting pollination (150). We should not, therefore, wage indiscriminate warfare upon all insects.

277. Preventive methods. — Methods of preventing insect ravages to plants are various, as inclosing the plants, trapping, repelling or removing the insects, destroying them by means of insecticides, or preventing reproduction by destroying the eggs. The important question in the case of any injurious insect is by which one of these methods it may be most effectually and cheaply controlled.

278. Inclosing the plants is practicable in a few cases, as with the striped cucumber beetle (*Diabrotica vittata*). The hills in which cucumbers, melons, squashes

and the like are planted, may be covered with a frame having fine-meshed wire or cotton netting tacked over the top, which prevents the beetles from gaining access to the plants (Fig. 67).

279. Trapping the insects is practicable in a few cases, as with cutworms, which often conceal themselves during the day beneath objects on the ground. They will frequently be found in numbers beneath handfuls of green clover or other herbage placed on the ground near the plants which it is desired to protect. By poisoning the herbage (283), some of the cutworms may be killed, but many are likely to escape unless destroyed by other means.

280. Repelling insects by means of offensive odors is partially effective in some cases, as with the squash-vine borer (*Melittia satyriniformis*). Corncobs or other objects, dipped in coal tar and placed among the plants, repel many of the moths that produce the borers.

281. Hand picking, *i.e.*, removing the insects from the plants by hand, is the most satisfactory method for destroying certain insects, as the tobacco or tomato worm (*Phlegthontius sexta*) and other large insect larvæ and the rose-beetle (*Macrodactylus subspinosus*). A vessel of water with a little kerosene on the surface, in which to throw the insects as they are gathered, is a convenient way of destroying them. In some cases the insects can be shaken or knocked from the plant directly into the vessel. This method is often employed in destroying the potato beetle (*Leptinotarsa decemlineata*). Digging out cutworms and white grubs (*Lachnosterna*) from about corn and strawberry plants, and cutting out borers from trees and squash vines are often the most effectual methods for destroying these insects.

282. Poisoning. — Destroying insects by poisons or caustics is the method most generally available. The material used is called an insecticide, and if satisfactory, must be destructive to the insects without injuring the plant to which it is applied, or rendering the plant or its products unfit for food. The insecticides in most general use are certain compounds of arsenic (paris green, london purple, white arsenic, arsenate of lead), hellebore and pyrethrum powders, tobacco, kerosene and various compounds of soda and potash. With the exception of kerosene and the soda and potash compounds, all of these may be used either as dry powder or with water.

283. The arsenic compounds are effectual as insect destroyers, even when largely diluted. When applied in water, however, they are liable to injure foliage in proportion to the amount of soluble arsenic they contain. Since they are largely insoluble in water, they require stirring to keep them in suspension.

284. Paris green (arsenite of copper), when pure, is a nearly insoluble compound and may be safely used upon most plants, when diluted at the rate of one pound to two hundred gallons of water. For the peach and nectarine it should be diluted one-half more. Pure paris green dissolves without sediment in ammonia water, hence where adulteration is suspected this test may be applied.

285. Arsenite of lime, a very cheap arsenic compound, may be prepared by boiling one pound of powdered white arsenic and two pounds of fresh lime in two gallons of water for twenty minutes, stirring occasionally. For use dilute to 400 gallons. This costs only one-fourth as much as paris green.

286. Arsenate of lead contains less soluble arsenic, remains longer in suspension and sticks to the foliage

better than paris green and has therefore largely replaced it as a poisonous insecticide. It may be prepared at home, but this is a rather unsatisfactory method and as it can be readily secured upon the market, home preparation is not recommended.

Commercially it can be secured either as a powder or as paste. The powdered form has more recently come upon the market and is preferred by many users of this insecticide. The amounts to use vary somewhat with the insect which is to be controlled. Ordinary applications are one and one-half pounds of powdered arsenate or three pounds of paste arsenate to fifty gallons of water.

It is also offered upon the market under different trade names but as these are no better than the common forms and usually cost more, their use is not recommended.

287. Other arsenites. — London purple (arsenite of lime, with certain impurities) was one of the first arsenical poisons used. It was cheaper than paris green, which accounted largely for the extent to which it was used. It was variable in its chemical qualities, often containing considerable soluble arsenic, which caused injury to the foliage. For these reasons it has practically passed out of use. Arsenite of zinc has recently been placed upon the market as an insecticide for use with certain plants. It is largely in the experimental stage at the present time and therefore should be used with considerable caution.

288. Poisons. — Compounds of arsenic are deadly poisons and should always be handled with the greatest care.

289. Hellebore powder, the ground root of white hellebore, is a far less virulent poison than the arsenic compounds. Some persons do not like to use arsenic

compounds on plants or fruits which are to be used soon after the poison is applied. Hellebore is frequently used, therefore, against such insects as the imported currant worm and the cabbage caterpillar.

Hellebore powder, when used dry, may be diluted with once or twice its bulk of flour, which causes it to adhere better to the foliage than if used alone. When applied with water, a heaping teaspoonful or more may be added to three gallons. The dry powder is very light and should only be used in a still atmosphere.

A decoction made by boiling the root of white hellebore in water is said to possess insecticide properties similar to those of the powder.

290. Pyrethrum powder (Persian insect powder, Dalmatian insect powder, Buhach) is the pulverized flowers of certain species of *Pyrethrum*.¹ Pyrethrum powder is not poisonous to the higher animals, but the oil that pervades it is destructive to many insects. As the oil is extremely volatile, pyrethrum is better adapted for use under glass or with plants otherwise inclosed. It is not injurious to foliage or flowers. Fresh and pure pyrethrum powder may be diluted half or more in bulk with any other light, cheap, harmless powder, but the mixture should stand a day or two before use, to enable the diluent to absorb the oil. The powder may be used with water at the rate of half a pound to three gallons.

The pyrethrum plant is comparatively hardy and has been successfully grown in northern United States. It

¹ "Persian insect powder" is made from the flowers of *Pyrethrum roseum* and *P. carneum*; "Dalmatian insect powder" and "Buhach" are made from those of *P. cinerariaefolium*. "Buhach" is the trade name of a pure product prepared in California.

is said that a decoction of the unopened flowers possesses the insecticide properties of the commercial product.

291. Keeping these powders. — Hellebore and pyrethrum powders should be kept in close vessels, since their poisonous properties are volatile. In purchasing, only fresh samples should be accepted. If fresh and pure, these powders produce a tingling sensation when applied to the nostrils.

292. Tobacco smoke is much used for destroying "lice" or "green fly" (aphids) on plants under glass. For this purpose, the partially dry stems or leaves are burned upon pans or bricks, or in small sheet-iron stoves. There are also powdered forms of tobacco on the market which can be used in much the same way. Many delicate flowers are, however, injured by tobacco smoke.

Stems or leaves of tobacco, strewn abundantly beneath greenhouse benches, tend to prevent the multiplication of aphids.

Several semifluid extracts of tobacco are sold which may be evaporated in the greenhouse over an oil stove, or preferably by steam under pressure. Some of these are very efficient for destroying insects and do not injure flowers.

293. Tobacco solutions. — A strong decoction of tobacco is often used for destroying aphids on plants in rooms where tobacco smoke would be objectionable. The plants are immersed in, or washed with, the decoction. It is often effectually used on young plants of cabbage, cauliflower and turnip, to prevent their destruction by the flea beetle (*Phyllotreta vittata*). Florists commonly use strong extracts of tobacco, sold under different proprietary names, as tobacine, nicotine and the like, for destroying plant-lice. They are much diluted and

applied as sprays. Nicotine sulfate is a more recent spray material with similar properties which has largely replaced the other forms of tobacco sprays with commercial growers.

294. Kerosene is a very useful insecticide for a class of insects not readily destroyed by other means (316). It has generally been used as an emulsion made with soap and water, for which the following formula is good :

Dissolve one-half pound of hard soap in one gallon of boiling soft water ; add at once two gallons of kerosene, and churn or otherwise violently agitate for five or ten minutes.

This is a stock solution and must be diluted before use. The amount of dilution depends upon the season of the year when applied, the kind of plant to which applied and the insect to be controlled. When plants are dormant it may be put on as strong as 25 per cent kerosene. It may be applied, when the plants are in leaf, much stronger on apples and other hardy-leaved plants than it can to tender-foliage plants, as peach. It will need to be stronger to control some insects than others. For plant-lice, against which it is commonly used, the usual strength is about five to seven per cent.

295. Lime sulfur wash is largely used for the control of scale insects. The wash is prepared by boiling together definite amounts of stone lime and powdered sulfur. As this material can be secured upon the market in commercial form, home preparation is not recommended. It is applied during the dormant period of the tree, usually at the rate of one part of lime sulfur to seven to ten of water. The exact amount of dilution is determined by the use of the hydrometer. The material

to be applied to the dormant trees should have a specific gravity of 1.03.

296. Resin (or rosin) washes are valued for destroying various scale insects in southern and western United States. They are adapted with modifications to both dormant and growing trees. The resin is sometimes saponified with caustic soda and simply diluted with water; fish oil or petroleum may also be added. The following and other formulas are in use:

(a) Dissolve one pound of caustic soda in one gallon of water in a covered iron kettle. Pour out half of the solution, and to the remainder add 8 pounds of resin and boil until dissolved. Then pour in very slowly the rest of the caustic soda solution and boil the whole, stirring it constantly, until it will unite with water, forming a liquid resembling milk. Dilute to 22 gallons for use. This mixture may be applied during the growing season; or

(b) Place 30 pounds of resin, 9 pounds of 70 per cent caustic soda and $4\frac{1}{2}$ pints of fish oil in a closed iron kettle and cover with five or six inches of water. Boil until the liquid has a dark-brown color, after which slowly add water until the whole makes 100 gallons; or dilute a part of the liquid at this rate, keeping the remainder as a stock solution. This is for use in the dormant season. For the growing season, similar but more dilute solutions are used.

297. Hydrocyanic acid gas. — Another method of destroying scale insects is to treat the tree, previously inclosed in an oil-cloth tent, with hydrocyanic acid gas. One ounce of cyanid of potassium and one measured ounce of sulfuric acid are placed in an earthen or leaden jar containing three fluid ounces of water. The jar is

covered with burlap to prevent the rapid escape of the gas. The tent is left over the tree fifteen minutes to one hour. It is advisable to apply this treatment during the dormant season and in a cool season. Laws in some states now require that nursery stock be treated with hydrocyanic gas before shipment, to prevent the dissemination of dangerous scale insects. Hydrocyanic acid gas is a deadly poison, only small amounts being necessary to cause death, therefore its use is only recommended in the hands of experienced persons.

298. Fir-tree oil is considerably used in greenhouses and conservatories for destroying scale insects and the mealy bug (*Dactylopius*). It is mixed with warm soft water at the rate of a tablespoonful of oil to a pint, and applied with a syringe; or the plants are dipped into the mixture.

299. Hot water may also be used for destroying the above-named insects (298) and plant-lice (aphids). Infested pot-plants are inverted and immersed five or six seconds in a vessel containing water at 120° F. This treatment must be used with caution.

Forcible syringing of plants with water is also an excellent method of ridding greenhouse plants of insects.

300. Numbers of insects. — Insect attacks sometimes become formidable from the vast number of the individuals. The chinch-bug (*Blissus leucopterus*), the army-worm (*Leucania unipuncta*) and various species of locusts or grasshoppers sometimes devastate large tracts of country. For the destruction of these insects, special means must be employed.

301. The chinch-bug may be controlled, in a measure, by burning over all grass land early in spring, in

seasons when attacks are expected. The bugs may be kept out of corn fields by plowing a furrow away from the corn, on the side from which the attack is looked for, and strewing stalks of fresh corn in this. As the insects congregate on the corn in the furrow, they should be destroyed with kerosene (294). Persistent and thorough work is essential to success.

302. The army-worm may often be prevented from migration by plowing a deep furrow, as above directed, and making the side toward the endangered crop vertical, with a spade or shovel. The insects will congregate in the furrow, where they may be destroyed by dragging a log over them.

303. Grasshoppers and locusts may be destroyed, before they have attained their wings, by drawing over the infested ground a "hopper-doser," which consists of a shallow,

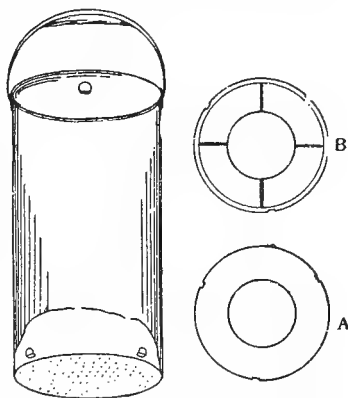

FIG. 68. — Sifting-box for applying powders.

sheet-iron pan, with a vertical, cloth-covered back. The pan contains a little kerosene, and the cloth back is kept saturated with the same liquid. The insects jump into the pan or against the cloth back; thus becoming wet with the kerosene they soon perish. Grasshoppers may also be poisoned by distributing bran mixed into a mash with water containing arsenic in solution. Plowing grass land containing the eggs of grasshoppers tends to prevent an attack.

304. Apparatus for applying insecticides. — Powders are readily applied to low-growing plants, such as the potato, cabbage and the like, by means of a sifting-box consisting of a pail with a perforated bottom, a rigid handle and a tight-fitting cover (Fig. 68). For small plants, such as young potato tops, the tin disk *A*, which has a circular hole in the center, is laid inside on the

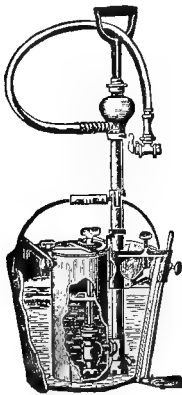

FIG. 69.

FIG. 69. — Bucket sprayer for small trees and bushes.

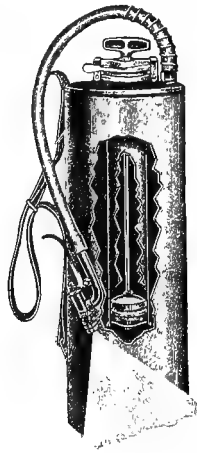

FIG. 70.

FIG. 70. — An atomizer or hand cylinder pump.

bottom of the box, and held in place by small lugs soldered to the wall as shown. When it is desired to spread the powder more, the disk *B* is used.

For taller plants, a powder bellows or power dusting machinery is desirable.

Liquid sprays are best applied with a hand atomizer, knapsack or bucket pump (Fig. 69), or a spray pump. An atomizer, to be carried by the operator as in Fig. 70,

is very useful for greenhouses and grounds. The size and number of the plants to be sprayed will largely determine the kind of spray apparatus to be used. The atomizer and knapsack pump are adapted only to rather small plants when they are few in number. In the home or small commercial orchard hand pumps may be used. Sometimes a portable outfit is made by mounting a

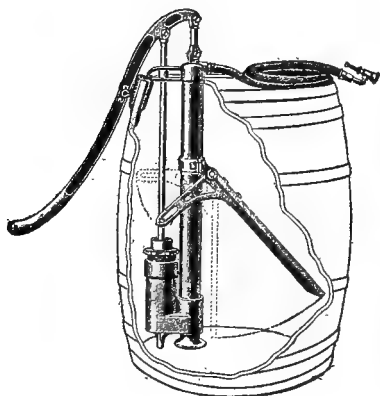

FIG. 71.

FIG. 71. — Barrel pump for small orchard.



FIG. 72.

FIG. 72. — A good spray outfit for a garden or a plantation of low trees.

barrel on wheels, as in Fig. 72. There are two general types now on the market: one in which the handle works vertically (Fig. 71), and in the other horizontally. The latter is more expensive, but is adapted to larger orchards and is easier of operation. For large commercial orchards power pumps, usually operated with compressed gases or with gasoline (Fig. 73), are most economical and efficient. If good work is to be done in spraying trees, a rod to elevate the nozzle into

the top of the trees is necessary. These rods, known as extension rods, are most frequently made of a bamboo pole with a small brass tube running through the center.

Nozzles are of various types, but one which breaks the spray up into a fine mist is, as a rule, most desirable (Fig. 74). The cyclone or eddy-chamber type of

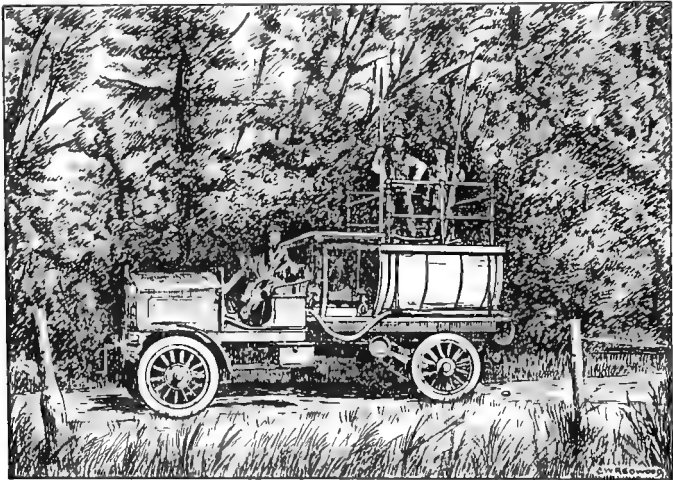

FIG. 73. — Power sprayer for commercial orchard.

nozzle, of which the Vermorel is a good example, seems to be most efficient in producing this character of spray. The disk nozzle, constructed on much the same general principle as the eddy-chamber type and made so as to set at an angle with the extension rod, is the type most largely used. The Bordeaux type of nozzle is used to some extent for special purposes.

Many of the common spray materials are merely held

in suspension in the water with which they are diluted, and unless there is some means of keeping the water in motion they settle to the bottom of the container, making even distribution and efficient work impossible. Spray pumps should therefore be fitted with an agitator to keep the spray materials in suspension.

305. The use of insecticides. — In treating any given insect, the most important question to decide is the

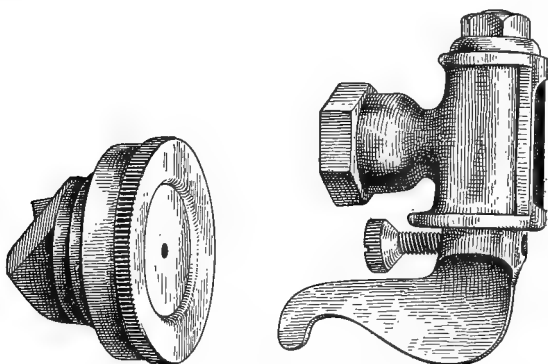

FIG. 74. — Disk nozzle (left) and Bordeaux nozzle (right).

manner in which it appropriates its food, as upon this will depend the preventive measures to be used.

306. Classes of insects. — Injurious insects are referable to two classes, viz., eating insects, *i.e.*, those feeding directly upon the plant tissues, such as the potato beetle, the apple-tree borers (the round-headed apple-tree borer is *Saperda candida*; the flat-headed apple-tree borer is *Chrysobothris femorata*), the plum curculio (*Conotrachelus nenuphar*) and the sucking insects, *i.e.*, those feeding only upon the juices of the plant, such as plant-

lice, the squash bug (*Anasa tristis*) and the oyster-shell scale (*Lepidosaphes ulmi*).

307. The eating insects may be subdivided into leaf-eaters, those that devour the foliage; root-eaters, those that devour the roots; and burrowers, those that tunnel through some part of the plant by eating a passage for their bodies.

308. The leaf-eaters include numerous species. They are readily recognized by the fact that the leaves, on which they feed, disappear more or less rapidly. They may generally be destroyed by applying a poison to the foliage, for which purpose the arsenical compounds are well adapted (283). In cases where the use of a deadly poison is unsafe, hellebore (289) or pyrethrum (290) may be substituted.

309. The root-eaters include fewer species than the leaf-eaters and are usually more difficult to control. Carbon bisulfid, injected into the soil about the roots of cabbage and cauliflower plants, with an instrument devised for the purpose has been successfully used to destroy the cabbage maggot (*Pegomya brassicae*) and may be found useful in other cases. Attacks of this insect have also been successfully prevented by surrounding the stem of the young plant with small cards of thin tarred paper. One of these cards, the tool used for cutting them and the manner of using the tool are shown in Figs. 75, 76 and 77.

310. Burrowers, as the term is here used, include not only the so-called borers that burrow within the stems and roots of plants, and the leaf miners, that live between the surface of leaves, but also the insects that pass their larval stage within fruits. Insects of this class are difficult to control, since they are mostly beyond the reach of insecticides.

311. Borers that infest the trunks and main branches of trees may often be kept out by applying strong alkaline washes to these parts. Soft soap reduced to the consistency of thick paste by a strong solution of washing soda, applied to the trunk or branches, forms a rather

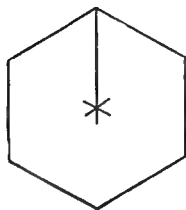

FIG. 75.



FIG. 76.

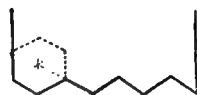

FIG. 77.

FIG. 75. — Card of tarred paper, for placing about the stems of young cabbage and cauliflower plants. Reduced one-half.

FIG. 76. — Tool for cutting the cards.

FIG. 77. — Manner of using the tool. The dotted lines show the position of the edge of the tool on the paper.

tenacious coating which repels the female insect. Painting the trunks of small apple trees a short distance above and below the surface of the ground with common paint or pine tar, is said to prevent the entrance of the round-headed borer (306). Protecting the trunk with straw or lath, as recommended to prevent sun-scald (185), may tend

to keep out these insects. Borers in the trunk can often be destroyed by probing their holes with a flexible twig.

312. Leaf-miners often infest the leaves of various plants. They may cause considerable injury by so destroying the chlorophyll tissues as to interfere with normal photosynthesis (58), and also by making leaves of spinach and beets, grown for greens, unfit for use. These insects are exceedingly difficult to control, since they feed by tunneling between the two leaf surfaces, as indicated by their name. The most satisfactory methods consist in frequent cultivation during the time the pupa is in the ground or burning the fallen leaves in those cases where the insect pupates in them.

313. The codlin-moth (*Carpocapsa pomonella*), which causes so-called "wormy" apples and pears, is controlled by spraying the trees with water containing paris green (284) or arsenate of lead (286). The first spray should be applied three to seven days after the petals (142) fall, to be followed by a second about ten days later. Another application is necessary in some states to control a second brood of this insect. The time will vary in different states. In Wisconsin July 15 to 30 is about the proper date, depending upon the season. A drop of poisoned water should be lodged in the calyx (141) of every fruit, and as this evaporates, the poison deposited on the skin kills the newly-hatched insect as it eats its way inward.

A band of cloth or paper, placed about the trunk of fruiting apple or pear trees forms a convenient retreat for larvæ of the codlin-moth, in which to pupate. They may then be readily destroyed by removing the band. The bands should be a few inches wide, and should be put on before midsummer. They should be taken off

once in ten to fourteen days, until the fruit is harvested, and all cocoons beneath them should be crushed.

314. The plum curculio (306) that so often stings young plums, causing them to drop before maturity, is controlled by jarring the beetles, that deposit their eggs in the young fruit, upon sheet-covered frames very early on cool, still mornings while their muscles are stiff (Fig. 78). The jarring should begin almost as soon as the petals (142) fall and should be repeated every still morning as long as any beetles are found.

Any light wood frame, covered with cloth, may be used as a substitute for the more convenient device shown in the figure. Where the substitute is used, the beetles must be looked for on the sheet and destroyed as found.

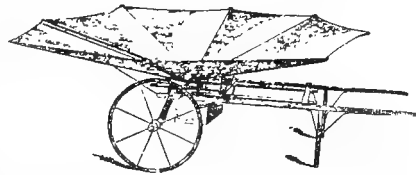

FIG. 78. — Curculio catcher. It is wheeled beneath the branches of the tree, and the latter are struck with a light, cloth-covered mallet, which jars the beetles upon the sheet-covered frame, from which they roll into the box beneath. For small trees, the trunk slips in through the slot at the left.

Arsenical poisons applied as soon as

leaves appear on the trees and at frequent intervals thereafter are also very beneficial in the control of this pest.

315. Destroying fruit. — The prompt destruction of infested fruit materially aids in keeping the fruit-burrowing insects in subjection. Hogs and sheep in the orchard are most valuable assistants in this work. The apple-maggot (*Rhagoletis pomonella*) is more effectually controlled in this manner than by any other known method.

316. Sucking insects include many species. They

feed on the juices of the plant which they infest, and do not directly devour its tissues, as do the eating insects; but they reduce its vitality by their continued drain upon the reserve food. The so-called scale insects belong to this class. These are especially difficult to destroy, since they are dormant the greater part of the year, and in this condition are protected by their comparatively resistant scales.

Sucking insects are not susceptible to poisonous insecticides, hence we must resort to materials that clog their breathing pores, that dissolve their eggs or scales or that form an air-tight coating over them.¹ The materials most often used for destroying this type of insects are lime-sulfur, kerosene emulsion and tobacco decoctions.

317. The life histories of injurious insects, which cannot here be taken up, may profitably be studied by the plant-grower. A standard work on economic entomology will furnish the needed information.

¹ The cottony cushion scale, *Icerya purchasi*, which was very destructive to the orange in California, has been nearly suppressed by the introduction of an Australian parasite, the *Vedalia cardinalis*.

CHAPTER XIII

PLANTS AS AFFECTED BY VEGETABLE PARASITES AND BY WEEDS

MOST of the vegetable parasites are less conspicuous or evident in themselves than are the quadrupeds, birds and insects, but their work is often peculiarly devastating and usually insidious.

318. Types of vegetable parasites. — Many of the most serious enemies of cultivated plants belong to this class. As a rule, vegetable parasites contain no chlorophyll, and hence are incapable of forming their own food. While most of them belong to the lower orders of plants, a few species are of the higher types and produce true flowers and seeds. Of parasites of the higher orders, seed plants, the only ones sufficiently common or injurious to need mention are the broom rape and the dodders.

319. The broom rape of hemp and tobacco is the most injurious species of this class. The seeds germinate in the soil, and the young plants attach themselves to the roots of their host, which they enfeeble by robbing them of nourishment. In the case of hemp, the parasite also injures the quality of the fiber.

Preventives. — The seed of hemp or tobacco should not be taken from a crop infested with broom rape. Infested fields should be planted for several years to some

crop not attacked by broom rape, as potatoes, Indian corn, beans, grains or grasses. In infested crops, the broom rape should not be permitted to mature its seeds.

320. The dodders of clover and flax (*Cuscuta epithy- mum*, *C. epilinum*) are the most injurious of their class. The young plant attaches itself to the stem of its host, about which it twines, robbing it of nourishment by means of small suckers.

Preventives. — The seeds of dodder are somewhat smaller than those of clover or flax, and hence may be separated from the latter by sifting. Badly infested ground should be devoted for two to four years to a crop not attacked by the dodder.

321. Parasites of the lower orders, spore plants. — The lower parasites include the fungi and bacteria.¹ These two groups are, however, so similar that we need here only call attention to the fact that the bacteria are even more minute than the fungi and as a rule more difficult to combat. These minute plants, fungi and bacteria, constitute an extensive group of organisms which derive their nourishment from organic matter. Most of them are saprophytes living in dead organic materials, but others are parasites (25) upon the higher plants or animals, causing various diseases. Unlike the harmful insects, most of which work their ravages within full view, the bacteria and fungi are in most cases discernible only with the microscope, and reveal their presence only by the death or injury of their host. These parasites are very numerous and exhibit great diversity of structure and habit. Some of them live only upon enfeebled plants, while others attack healthy ones. Some, as the pea mildew,

¹ Singular, *fungus*, plural, *fungi*; singular *bacterium*, plural, *bacteria*.

grow upon the surface of their host, drawing their nourishment through the epidermis; others, like the oat smut and the bacterial blights, grow within the tissues of the plant upon which they feed. Most of the fungi send their fruiting parts to the surface of the host plants, where they produce spores (52) in immense numbers. The bacterial developments more often take the form of slimy exudates which may ooze from the surface as with fire blight of pear. Such fungous spores are most frequently disseminated by the wind, and the bacteria by insects, although water and other agencies, including man, may also play important parts in their distribution.

322. Methods of controlling plant diseases are numerous and varied, but those most effective may be grouped into three classes:

(a) Removing and destroying the affected parts.

(b) Preventing infection, chiefly by the use of a fungicide.

(c) Increasing the resistance of the host to the parasite.

323. Destruction of the affected parts is especially important with the bacterial diseases, such as fire blight of pear and apple (*Bacillus amylovorus*), where spraying is in general useless. This method is applicable with certain conspicuous fungi which spread rapidly from part to part, as brown-rot of stone fruits (*Sclerotinia fructigena*) and corn smut (*Ustilago zaeae*) and also with certain fungi which tend to spread through the plant tissues, like the red rust (*Gymnoconia interstitialis*) of raspberry and blackberry and the black knot (*Plowrightia morbosa*) of plum and cherry.

The affected part should be removed as soon as discovered and burned at once, to destroy any spores or germs of the parasite it may contain or which might

mature later. It is generally important to cut the diseased branch some distance below the point of visible infection, as in many cases the parasitic invasion extends farther than external appearances indicate.

324. Infection may be prevented best as a rule by destroying the spores through the use of chemicals (fungicides) or by heat. According to the nature of the parasite this may be accomplished either by soil treatment, seed treatment or treatment of the aërial parts of the plant.

325. Soil treatment is necessary in the case of certain organisms that live over in the soil and attack the young plant as it germinates. The organism causing club root (*Plasmodiophora brassicae*) of cabbage persists a long time in soil that is slightly acid, but by adding lime, 75 to 120 bushels to the acre, to render it alkaline the organism is destroyed. Onion smut (*Urocystis cepulae*) also lives over in the soil, but by applying sulfur, or better, formalin solution (2 ounces in 1 gallon water) in the drill along with the seed, infection is prevented.

The most serious trouble with seedlings in general is caused by the damping-off diseases¹ caused by fungi which live in the soil and invade the young stems and cause them to rot off at the surface of the ground.

326. Soil sterilization is the most effective remedy for damping-off fungi. Sometimes chemicals, especially formaldehyde, can be used for this purpose but in general heat is the best agent. The simple way sometimes employed of generating the heat is to burn brush on the spot to be used as a seed-bed. The most effective and widely applicable measure is steam sterilization. For this pur-

¹ There are a number of fungi capable of causing damping-off of plants in the seed beds; the most common of these are species of *Pythium*, *Rhizoctonia*, *Fusarium* and *Thielavia*.

pose in the greenhouse steam may be introduced through perforated pipes buried in the soil. The method most in favor, however, is to invert a large metal pan over the bed into which live steam at high pressure is discharged (Fig. 79). In this way the surface layer of the soil may be so "cooked" in about one-half hour that not only are the disease germs destroyed, but also the weed seeds. In

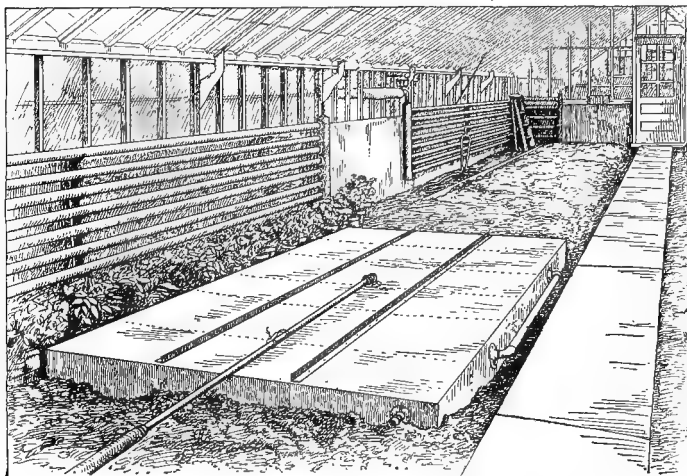

FIG. 79. — Steam sterilization of greenhouse soil.

tobacco seed-beds, the labor-saving as a result of so killing the weed seeds pays for the expense of steaming.

327. Seed treatments aim to disinfect seed without injuring its germination. This can be accomplished in certain cases, *e.g.* (barley smut), by immersing the seed a short time in hot water. The simplest agent is the chemical formaldehyde. Thus oat smut is prevented by soaking the seed two hours in a solution of 1 pint of this

in 40 gallons of water. Corrosive sublimate solution (1 pint in 1000 of water) is used in a similar way, *e.g.*, with potatoes.

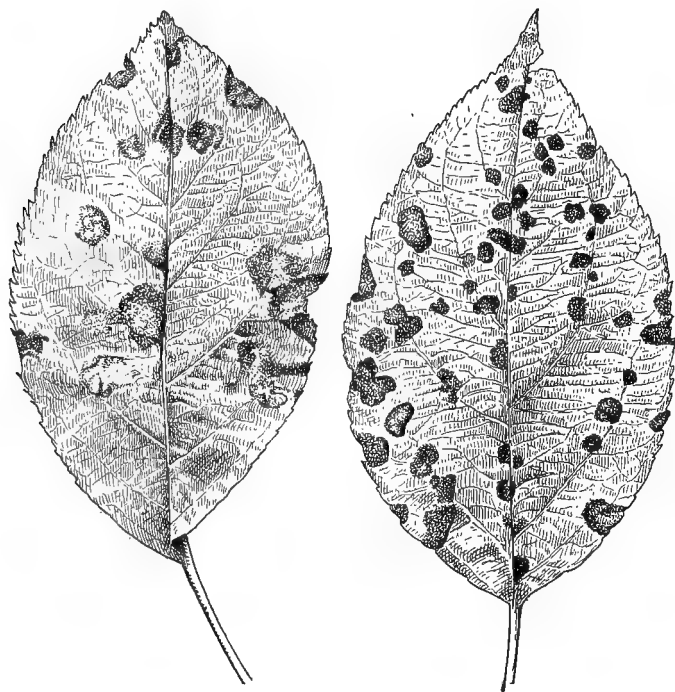

FIG. 80. — Apple-scab on leaves.

328. Spraying aerial parts with fungicides aims so to coat the surfaces of the healthy leaves, fruit or branches, that spores falling upon them will be destroyed. Its purpose is always to prevent disease rather than to cure it. The spraying must, therefore, precede the spread of

the disease and be so thorough as to cover all susceptible parts, else it cannot be fully effective. Such thorough spraying requires a spray pump of high pressure provided with a fine nozzle.

Some of the common diseases preventable by proper spraying are: scab of apple (*Venturia inaequalis*) and pear (*Venturia pyrina*), downy mildew (*Plasmopara viticola*) and black-rot (*Guignardia bidwellii*) of grape, early blight (*Alternaria solani*) and late blight (*Phytophthora infestans*) of potato, brown-rot (*Sclerotinia fructigena*) and leaf-curl (*Exoascus deformans*) of the peach and the shot-hole disease (*Cylindrosporium padi*) of the cherry. The apple-scab as it appears on leaves is shown in Fig. 86; as it appears on fruit in Fig. 81. A section through a scabby spot, magnified, is represented in Fig. 82.



FIG. 81. — Scab on the apple.

329. Fungicides. — The most important fungicides in common use contain some form of copper or sulfur, although there are numerous other compounds having fungicidal properties. The practical value of a fungicide depends upon its ability to destroy the fungus without serious harm to the host, coupled with convenience of preparation or use, adhesiveness and cheapness. The copper compound best meeting these standards is bordeaux mixture; and lime-sulfur is the best sulfur compound. In general, the bordeaux mixture has greater fungicidal value but the lime-sulfur has replaced it for certain uses, partly because it has also value for controlling certain insects (295).

330. Bordeaux mixture is made of copper sulfate (blue vitriol) and lime. There may be a considerable variation in strength or proportions of the ingredients, according to plant or conditions. A formula in common use is the "5-5-50," *i.e.*, 5 pounds of copper sulfate, 5 pounds of lime and 50 gallons of water; although weaker mixtures, 4-4-50, or even 3-3-50 are gaining in favor.

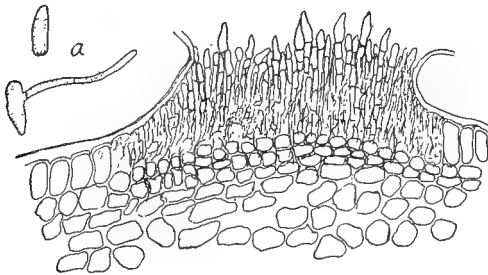

FIG. 82. — Diagrammatic section through an infection by the apple-scab fungus.

To prepare the mixture, dissolve the copper sulfate in one vessel, dilute with about one-half the total amount of water to be used (25 gallons). Slake the lime in another vessel, dilute with the balance of the water (25 gallons); then strain the two together and stir thoroughly. The light blue compound formed is the essential thing in the fungicide. If allowed to stand, it gradually settles and loses some of its fungicidal value, hence it is necessary to have an agitator attached to the spray pump (304) and the mixture should be freshly made as used. Since the copper corrodes iron and other common metals, the mixture is best made in wooden vessels and the pump should have brass working parts.

The copper sulfate alone is so caustic that it will "burn" the plants, but the lime largely neutralizes this caustic action. If the lime is good, the above formula supplies it in excess and insures neutralization. If, however, the lime is poor or one is in doubt, there are certain tests which may be applied.

If much spraying is to be done, it is convenient to make up considerable quantities of "stock solutions" of each of the ingredients, copper sulfate and lime. These are best made to contain one pound of the chemical in each gallon of water. These solutions may be kept indefinitely by simply guarding against evaporation.

The arsenical compounds (283) may be added to the bordeaux mixture and thus a single treatment serves for both insects and fungi.

331. Ammoniacal solution of copper carbonate possesses nearly the same fungicidal properties as bordeaux mixture, but adheres less strongly to foliage. Being a solution, it requires no straining or stirring, and it leaves less stain on drying than bordeaux mixture, which makes it preferable to the latter for use upon plants of which the fruit is nearly mature. To make this solution, dissolve one and one-half ounces of precipitated copper carbonate in one quart of strong commercial ammonia, and add 25 gallons of water. The ammonia should be procured in a glass or earthen vessel, which should be kept tightly corked. To prevent waste of the ammonia by evaporation, prepare immediately before spraying.

332. Lime sulfur (295) is also employed extensively for the control of fungous diseases. Greater dilution is practiced for fungous diseases than when this material is used as an insecticide. At one part lime sulfur to thirty or thirty-five of water applications can be

made when the trees are in full leaf. A modified lime sulfur known as self-boiled lime sulfur is used on tender plants which are injured by the boiled product. For the preparation of this material students are advised to consult the bulletins of the United States Department of Agriculture.

333. Other forms of sulfur are also used, especially for the powdery mildews of the hop, rose and of various greenhouse plants. The simplest method is to dust the flowers of sulfur freely over the plants. Another simple sulfur compound used for mildews and the like is potassium sulfide (livers of sulfur), 1 ounce in 2 to 4 gallons of water.

334. Non-parasitic diseases also occur and one should not make the mistake of concluding that when a plant looks sickly this is always due to a fungous or insect parasite. Some of the commonest maladies, like tip-burn of potato, are directly due to dry heat, or other unfavorable environmental condition.

335. Resistance to disease. — Plants vary in susceptibility to disease, some varieties and some individuals in the variety excelling in hardiness or disease-resisting quality. Thus with fire blight the Bartlett pear and the Yellow Transparent apple are highly susceptible, while the Kieffer pear and the McIntosh are more resistant. The selection or breeding of plants for disease-resistance is, therefore, one of the important ways of lessening loss from diseases which the plant cultivator should always bear in mind.

It should also be noted that crop rotation, pruning, thinning, watering and various other cultural practices may have an important influence on the development or control of diseases.

PLANTS AS AFFECTED BY WEEDS

336. Weeds are plants of the higher orders that persist in growing where they are not wanted. They injure the desirable plants about which they grow by robbing them of light, moisture and food, and their presence is an evidence of slovenly culture. The remarkable vigor and prolificacy possessed by many weeds would enable them to soon overcome most cultivated plants, but for the aid of the cultivator. As with harm-



FIG. 83.—Propagation: showing how plants of the sow thistle multiply from underground stems.

ful insects and fungi, prompt and persistent efforts are essential to the control of weeds in most cultivated grounds.

337. Kinds of weeds.— With reference to their term of life, weeds and other plants are divisible into three classes, viz.: annual, those that live but one season; biennial, those that live only two seasons; and perennial, those that live an indefinite number of seasons. Weeds of the first class usually seed most abundantly, and hence they are most widely distributed and appear in cultivated grounds in the greatest numbers. Those of the third class are commonly most tenacious of life and are therefore often most difficult to control.

338. Annual and biennial weeds, since they have a definite life period and multiply almost exclusively by seed, may be controlled by preventing seedage. To accomplish this with certainty, the plants should be destroyed before bloom, as many species possess enough reserve food to mature seeds sufficiently for germination, if cut while in flower.

339. Perennial weeds often multiply by suckers as well as by seeds (Fig. 83). Since the roots or underground stems whence the suckers grow (114) are hidden beneath the soil and are often extremely tenacious of life, weeds of this class are frequently very hard to eradicate. Persistent prevention of leafage, which starves the roots, is always effectual, though it is often very difficult to carry out since the suckers of some species grow with great rapidity. Yet, on the whole, no better remedy is known. Frequent plowing and cultivation of the infested ground is usually the most effectual means of preventing leafage.

Certain very tenacious perennial weeds, as the Canada thistle (*Cirsium arvense*) and the creeping sow thistle (*Sonchus arvensis*), when growing on deep, rich loams in which the roots spread freely below the plow line, may, it is said, be crowded out by seeding the land to grass, at less cost than they can be subdued by the plow.

If we have mastered the foregoing chapters, we are now prepared to enter upon a more advanced stage of culture, and to learn how to cause new plants to grow, and how to treat the plants thus grown that they may best serve our purpose.

The following books are recommended for reading in connection with the preceding chapter: Elementary

Meteorology, Waldo; Chemistry of the Farm, Warington; American Weeds and Useful Plants, Darlington; The Spraying of Plants, Lodeman; Economic Entomology, Smith; Fungous Diseases of Plants, Duggar; Diseases of Economic Plants, Stevens and Hall.

CHAPTER XIV

THE PROPAGATION OF PLANTS.—BY SEEDS, DIVISION AND CUTTINGS

THE plant has now been treated from the point of view of its hindrances and enemies, in several chapters. We may now consider the manipulation of the plant, by means of propagating, transplanting, pruning and breeding.

340. Propagation, as the term is generally used in plant culture, is the multiplication of plants, *i.e.*, reproduction (16) encouraged or directed by the knowledge, skill and care of the cultivator.

341. Methods of propagation.—Plants are propagated by numerous methods, but only two of these are distinct in kind, *viz.*, by seeds (or spores), and by division of the plant. In propagation by seeds, the embryo of the seed (53) is the vital center, being in reality a young plant. In propagation by division, a living bud (127) from the parent plant, or a bit of tissue capable of forming a bud, is substituted for the embryo of the seed. In seed propagation, the resulting plant is the product of sexual fusion (149), and hence cannot be considered as strictly a part of the parent only. It does not necessarily resemble the parent closely. In propagation by division, on the other hand, the resulting plant may be regarded

as simply a continuation of the growth of the parent in a new location, and generally closely resembles the parent.

342. Propagation by seeds is commonly practiced with annual and biennial plants and with perennials in which the reproduction of the exact parental form is unimportant, as in the cereals, forest trees and seedlings intended for grafting. This method is also used when variation in the progeny is desired, as in developing new varieties (438).

This is the most common method of propagating plants. It seemed appropriate to give nearly all of the needed directions for planting seeds in the first two sections of Chapter II. We add, therefore, only a few general rules deduced from the principles there stated.

(a) The soil in which the seeds are to be planted should be thoroughly crumbled, because the seeds must have access to the oxygen of the air, or they cannot germinate (31).

(b) The well-crumbled soil should be compactly pressed about the seeds, because the seeds cannot absorb moisture rapidly unless the seed-case is in contact with the moist soil particles at many points (27).

(c) The soil should be moist but not wet enough to puddle (31); otherwise the oxygen is likely to be shut out from access to the seeds (34).

(d) Seeds should be planted no deeper than is necessary to insure the proper degree of moisture; otherwise the plantlet expends a needless amount of energy in reaching the surface (47, 50). Very small seeds should be only slightly covered, if at all, and must receive artificial watering when necessary (51). Spores must not be covered with soil at all (52).

343. Propagation by division of the plant is used when it is desired to reproduce the exact parental form, as in fruit and the finer ornamental trees, many flowering plants and the like; in certain plants that are more readily multiplied by division than by seeds, as mint and many other perennial herbs; and in other plants that rarely or never produce seed, as the horse-radish, sugar cane, banana and so on.

We have seen that a part of a plant, placed under favorable conditions, is frequently capable of developing a complete plant (343). A section or cutting of the stem, for example, that has no roots at the time it is cut off, may be caused to form roots, and thus become a complete plant. A cutting of a root may also put forth a bud, which in turn may develop into a shoot, and form leaves, flowers and fruit. Again, we have seen that portions of cambium from different, nearly-related plants may unite by growth (69), which enables us to change undesirable sorts into valuable ones by grafting (383). These and certain other methods of multiplying plants come under propagation by division.

In propagation by division, the presence of at least one healthy growing point (66) in the part selected for the propagation is generally essential to success and is always helpful.

The processes treated in this and the two succeeding sections may be likened to surgical operations in medicine. If plants are less highly organized and possess less of sensibility than the higher animals, they are, none the less, living beings. Violent operations, if necessary, should always be performed with this truth in mind. Needless injury and careless handling in the treatment of plants are always to be avoided.

344. Methods of propagation by divisions. — Two methods of propagation by division may be distinguished, viz., by parts intact and by detached parts. In the first, the part selected for propagation is not separated from the parent until the organs needed to make it self-supporting are formed; or if a cion (386), until it has united to the part on which it is intended to grow. In the second method, the part intended for propagation is severed from the parent at the outset and placed under conditions favoring the formation of the organs needed to make it self-supporting; or if a cion, favoring its union with the stock (383).

345. Propagation by parts intact. — This method is applicable to many plants and has the advantages of being reliable and requiring little skill. The part selected for propagation, being nourished by the parent until it forms the needful organs, is able to endure unfavorable conditions that would prove fatal in most other methods of propagation. This method includes four divisions, viz., propagation by suckers (346), by stolons (347), by layers (348), and by approach grafting (399). In the first two, the propagation is performed by the parent plant without other aid than the maintenance of a well-aërated, moist and clean soil that stimulates the production of the needed organs, which in these cases are roots.

346. Propagation by suckers. — Suckers are shoots that originate from roots or underground stems and grow upward, forming young plants about the parent, as in the blackberry, plum, choke-cherry and the like. The propagation consists in simply cutting off the root or underground stem whence the sucker proceeds, and transplanting the latter.

The growth of suckers may generally be stimulated in plants that naturally produce them, by cutting off the

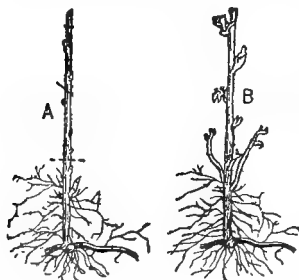

FIG. 84. — Sucker plant of the red raspberry, *Rubus strigosus*. A, before growth has started; B, after. The two shoots of B starting just above the roots form the new canes.

roots or underground stems from which they grow, or by severely pruning the top.

The propagation of woody plants from suckers is not, as a rule, considered wise, since the roots are usually poorly developed in proportion to the stem, and some plants grown in this manner seem to acquire the tendency to form suckers excessively. In the red raspberry (*Rubus strigosus*, *R. Idaeus*) and the black-

berry (*Rubus nigrobaccus*), however, propagation by suckers is the most convenient method, and it appears to be followed by no bad results (Fig. 84).

347. Propagation by stolons. — A stolon is a branch that starts above or at the surface of the ground and either grows prostrate or curves downward till it reaches the ground, where it takes root, usually at the nodes (115). The currant, juneberry, cranberry and many herbaceous plants are readily multiplied in this way. Stolons often root without assistance, but the rooting is much hastened and en-

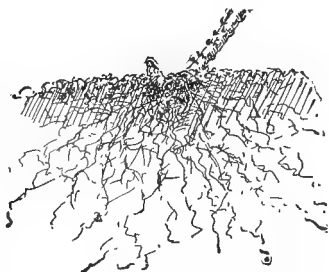

FIG. 85. — Tip plant of black raspberry. The bud, whence the young shoot starts, appears at the base of the present cane.

couraged by covering the branch with soil. When well rooted, the young plants may be separated from the parent by cutting the stolons.

Woody plants grown from stolons are seldom uniform in size and are not often so well rooted as those grown from cuttings (358). Some herbaceous plants are, however, more readily propagated by stolons than by any other means.

The offset by which the houseleek (*Sempervivum*) is so readily propagated, is a very short stolon that forms a single tuft of leaves at its apex. The cane of the black cap raspberry (*Rubus occidentalis*), which roots from the tip (Fig. 85), and the runner of the strawberry (Fig. 86), that forms a plant at each alternate node, are modified stolons.

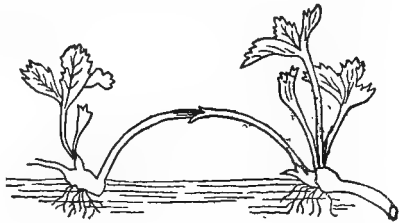

FIG. 86. — Runner of the strawberry.

348. Propagation by layers or layering. — The layer is an artificial stolon, *i.e.*, a branch that does not naturally grow downward, which is covered with or surrounded by moist soil or other media to stimulate the production of roots (88). The branch may be bent down and covered, as is usually practiced with the grape, wisteria, etc., or the soil may be ridged up about the branch, as is done with the quince and paradise apple. In either case the terminal portion of the stem is commonly left uncovered. In the latter method, which is known as mound-layering (Fig. 87), the stems of the plant to be layered are usually cut off just above the surface of the ground in early spring, to stimulate the formation of

vigorous shoots, which are ridged up about midsummer or preferably not until the succeeding fall or spring. The ridging should be sufficiently high to cover several of the lower nodes (115). Roots grow out at the nodes and the shoots are usually well rooted by the autumn following the ridging.

Many woody plants that do not readily form roots when layered may be induced to do so by mutilating the stem somewhat in the covered part. This tends to restrict the growth current (79) and causes accumulation of reserve food, from which roots may grow. Girdling, twisting, bending or splitting the stem for a short distance will often have the desired effect (Fig. 88).

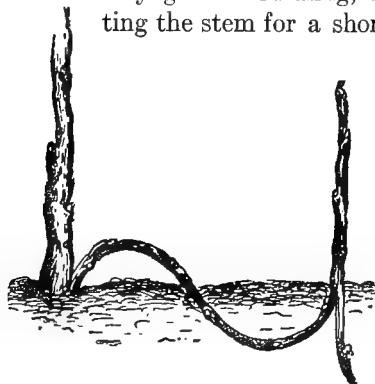

FIG. 88. — Layered branch of currant, split to encourage the formation of roots.



FIG. 87. — Mound-layering of gooseberry plants.

Layering is a very reliable and expeditious method of propagating many woody and herbaceous plants.

349. Propagation by division of the crown of the plant, which is practicable with many perennial herbs, as the rhubarb, dahlia, globe artichoke and the like, though not strictly analogous to propagation by stolons or layers, may be considered here. It consists in taking

up the plant, preferably while dormant, and cutting the crown into two or more parts, according to its size or the number of plants desired, and planting the divisions as separate plants. This method is applicable to propagation for private use, rather than for sale purposes.

Propagation by approach grafting, although in order here, is more readily treated with the other methods of grafting (399).

350. Propagation by detached parts. — This comprises two different modes of prop-

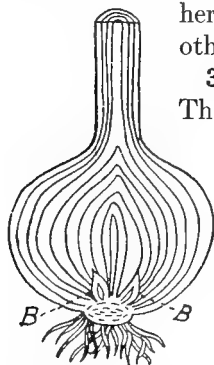

FIG. 89.

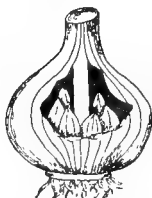

FIG. 90.

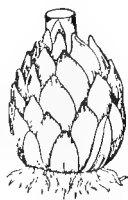

FIG. 91.

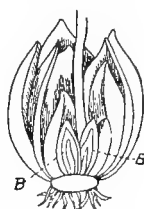

FIG. 92.

FIG. 89. — Bulb of the common onion, *Allium Cepa*, divided lengthwise. *B*, buds.

FIG. 90. — Bulb of garlic, *Allium sativum*. It contains several smaller bulbs (cloves).

FIG. 91. — Bulb of wild lily.

FIG. 92. — The same divided lengthwise, showing buds, *B*.

agation, viz., by specialized buds and by sections of the plant.

351. Propagation by specialized buds. — This includes propagation by bulbs, bulblets, corms and tubers. It is in a sense intermediate between propagation by parts intact (346) and by cuttings (358). The bud that is to form the future plant, though not having roots of its own, had been specially prepared by the parent, through an abundant food supply and a partially dormant condition of the protoplasm, to maintain a separate existence, even

under adverse conditions, and in due time to develop into a plant. In these respects it resembles a seed, from which it differs, however, in the less dormant condition

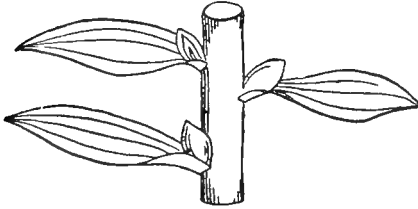

FIG. 93. — Bulblets in axils of leaves of tiger lily.

of its protoplasm and in not being the product of sexual fecundation (341). The scales are thickened by a store of food, and in their axils are smaller lateral buds. The terminal bud usually develops into a flower and then perishes. One or more of the lateral buds may develop into flower-buds for the next year and thus continue the life of the plant, as in the common onion (Fig. 89); or the lateral buds may develop at the expense of the parent, as in the potato onion.

353. Bulblets are small bulbs formed in the axils of the leaves in certain plants, as the tiger lily (*Lilium tigrinum*) (Fig. 93), or at the apex of the stem, as in "top" or bulb-bearing onion (Fig. 94).

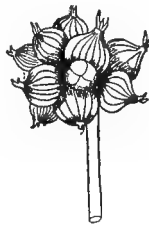

FIG. 94. — Bulblets of "top" onion, sometimes used as onion "sets."

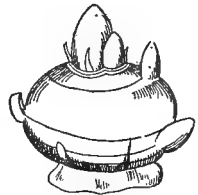

FIG. 95. — Corm of crocus, with small corms (buds) for following year.

354. The corm (Fig. 95) differs from the bulb chiefly

in being without fleshy scales. The food is deposited in the thickened stem. The corms of our flowering plants, as the crocus, cyclamen and the like, are generally called bulbs in commerce.

355. The tuber, of which the common potato is the most familiar example, differs from the corm in being the end of an underground branch of the stem (114), instead of developing in direct contact with the parent. It also has more numerous buds (eyes) than the corm.

356. Planting. — Propagation from bulbs, bulblets, corms and tubers is a very simple operation and consists merely in planting these parts in the place where the plants are desired. Tubers may be cut into pieces containing one or more buds each, if desired. The rules given for planting seeds (344) apply equally well here. All should be stored for preservation in a cool, moderately dry place, that is free from frost. They retain their vitality but a single year.

In the methods of propagation thus far considered, with the sole exception of layering (349), advantage has been taken of a natural mode of plant multiplication. The skill of the cultivator, however much it may assist the processes, is not necessary to their success, since wild plants habitually increase by the same methods. We will now consider a method which is less often illustrated in nature, and in which the skill and care of the cultivator are, as a rule, essential to its accomplishment.

357. Propagation by sections of the plant. — The various methods of propagation in this division are alike in the fact that a detached part of the parent plant, containing living protoplasm, is placed for a time under specially favorable conditions, in virtue of which the part is enabled not only to live, but to perform its functions

and reproduce the needed organs; or if a cion (386), to unite by growth to the part with which it is placed in contact.

In propagation by sections of the plant we must, of necessity, wound the plant tissues in securing the parts for propagation. Since it is always desirable that the wound should heal promptly (72), it is important that the cutting tools used should have sharp and smooth edges.

As here considered, propagation by sections of the plant includes two methods, differing materially in their requirements and in the manner of development of the plants, viz., propagation by cuttings and by grafting.

358. Propagation by cuttings. — A cutting is a detached part of a plant, intended to be placed in the soil or some other medium for the purpose of developing roots. It may be in an active or a dormant state (13) and may or may not contain a growing point (66). Before the cutting can become a plant, it must develop the essential part or parts of the plant that it lacks, *i.e.*, the stem and the leaves or the root, or all these members. Cuttings of the stem are usually planted with their proximal end (115) in the soil, and their distal end in the air. Root cuttings are generally covered in the soil.

359. Ease of propagation by cuttings. — Nearly all plants may be propagated by cuttings from one or another of their parts. The ease with which plants may be multiplied in this way varies greatly in different species (21), and even in different varieties of the same species. The appearance of a plant does not always indicate the facility with which it may be grown from cuttings; the only sure way to ascertain this is by trial.

Climate exerts a marked influence upon the tendency

of plants to develop from cuttings. In certain locations in southern Europe and in parts of South America, branches of the common apple tree, sharpened and driven into the ground as stakes, often take root and sometimes even bear fruit during the same season. A warm, moist atmosphere is very favorable to propagation by cuttings.

We have seen that the roots of certain plants normally develop buds (130). In like manner, the stems of many plants, as the potato, grape and the like, normally develop growing points of roots at their nodes (115). Plants that normally develop buds upon their roots, or growing-points of roots at their nodes, are readily propagated by cuttings. But propagation by cuttings is not limited to such plants (362).

360. Characteristics of a cutting.—The essential characteristics of a cutting are: a certain amount of healthy tissue; a certain amount of prepared food, or of tissue capable of preparing food (58); in most species, a growing point (66), or the power of developing one.

361. Parts used for cuttings.—The parts of plants to be used for cuttings, therefore, are preferably the younger, matured growths, since the tissues of these are most vigorous; or else a part that possesses a certain amount of healthy and vigorous leaf tissue. The cutting should always contain one or more buds when practicable (127).

362. Conditions that favor the growth of cuttings.—A soil warmer than the air above it ("bottom heat") is important in growing many plants from cuttings. Warmth stimulates plant growth, and when applied to one part of a plant, it stimulates growth in that part. If the soil about a planted cutting is warmed to a temperature considerably higher than that of the air above, the growth

of roots is stimulated. Indeed bottom heat often excites growth in cuttings that will not grow without it.

A comparatively low air temperature is important in growing many plants from cuttings of the stem (377), because it is essential that the stem growth be held in check until roots are formed. A soil temperature of about 65° F., with an air temperature about fifteen degrees lower, is suited to the layer member of plants usually propagated under glass from cuttings. It is important that these temperatures be maintained nearly constant until roots have developed.

Since we have better facilities for raising than for lowering the natural temperature of the atmosphere, propagation from cuttings is easiest at a time of the year when the temperature of the atmosphere during the day does not much exceed 50°. By observing special precautions, however, it is possible to propagate many plants from cuttings during the warm season.

Abundant moisture is important in growing plants from cuttings, because moisture favors root development (88), and water is essential to cell growth (62). The amount of water required varies considerably with different plants and conditions.

With cuttings containing leaf tissue (377, 382), transpiration (74) must be reduced to the minimum until roots are formed, because water cannot be taken up freely without root-hairs (100). For such cuttings, therefore, the air as well as the soil must be kept abundantly moist (369), and the direct rays of the sun must be intercepted by shading (235).

363. Methods for controlling temperature. — The alternations of temperature in the open air are unfavorable to the development of cuttings, though many

plants, as the willow, grape and currant, are readily propagated from cuttings out of doors. Some structure, therefore, that may confine warmth radiated from the earth or artificially generated, or that may when necessary shut out a part of the solar heat, is always of great assistance in propagating plants from cuttings, and in many species is essential to success. Since light is necessary to food preparation (58), such a structure must be roofed with glass or some other more or less transparent material.

364. The coldframe (Fig. 96) is the simplest structure of this kind. It consists of a frame or box without bottom, usually shallower on one side than on the other, covered with glazed window sash. Muslin or paper is sometimes used instead of glass,

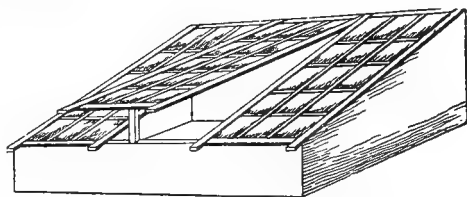

FIG. 96. — Coldframe, with sash lifted for ventilation.

and these materials may be rendered waterproof and less opaque by painting with linseed oil or some similar material. The frame is usually placed so that its shallower side faces the south, thus giving its cover a southward slope. It has no provision for artificial heat, though when covered with glass, the temperature within the frame is much increased during sunshine, owing to the property possessed by glass for confining the heat rays. The coldframe should be protected in freezing weather by an additional cover of mat or blankets, while excessive sun heat should be avoided by shading (235). Muslin- or paper-covered frames require no shading.

Although affording no bottom heat (362), the cold-frame may be used for propagating many plants from cuttings. It is also serviceable in connection with the propagating bed (368) for "hardening off" young plants grown from cuttings in the latter, as well as for growing many plants from seed. Set over a pit in the earth, the coldframe makes an excellent place (cold pit) for wintering half-hardy plants.

365. The hotbed (Fig. 97) differs from the coldframe in having bottom heat (362), which is usually supplied by the fermentation of moist vegetable material, as horse

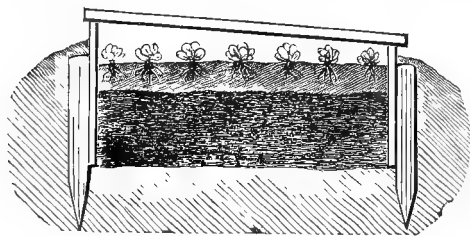

FIG. 97. — Cross-section of hotbed in pit. The frame is banked up a little with earth.

manure, leaves, refuse hops or tan bark. The material intended for heating, if fresh, should be thrown into a pile of sufficient size to generate

heat several days before it is desired for use; and unless already moist, it should be moderately sprinkled with water. In order that all the material may reach the same stage of fermentation, the mass should be made into a new pile after the heating starts vigorously, as is indicated by vapor rising from the heap, and the outer part of the mass should be placed in the center of the new pile. Leaves ferment slower than the other materials above named, and hence may often be advantageously mixed with them to lengthen the period of fermentation.

Heat is economized by placing the fermenting material in a pit in the ground, but hotbeds are often made

above ground. The hotbed pit should be in a well-drained and sheltered place, and two to two and one-half feet deep. In this the heating material should be moderately packed, until the pit is nearly or quite full. The frame may then be placed over the pit, after which the heating material should be covered with soil and the sash put on to confine the warmth. Within a few days after covering with the sash, the fermenting material usually generates a rather violent heat, which should be permitted to decline to about 90° F. before planting seeds or cuttings in the hotbed. The same protection against excessive heat or cold is used as for the cold-frame; but the hotbed requires much more care in ventilation, since the heating material generates vapor and carbonic acid, as well as heat, and these when present in excess are detrimental to plant growth.

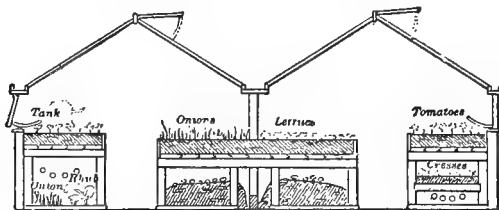

FIG. 98. — Cross-section of greenhouse.

366. The greenhouse is an expansion of the hotbed, *i.e.*, a structure sufficiently large so that it may be entered, and arranged for heating by fire. They are built in various sizes depending largely upon the use to which they are to be put. Ordinarily they extend north and south. Greenhouses are often built with one slope of the roof longer and less steep than the other, and with the ridge extending east and west. Such a roof is called

a "two-thirds" or "three-quarters span," according as the longer slope covers two-thirds or three-quarters of the width of the house. The long slope usually faces the south, but houses have recently been built with the shorter and steeper slope facing the south, a plan thought to possess advantages for growing certain plants, as carnations.

Provision is made for ventilation in glass houses by placing a certain number of movable sash in the roof or elsewhere (240). The walls may be of wood, brick or concrete. Concrete is rapidly becoming more popular as wall material and will doubtless largely replace all other materials for this purpose. The furnace and potting rooms obstruct the light least, and afford the most protection, when located to form the wall opposite the sun. In houses extending north and south, the south end is usually glazed above the height of the side walls.

367. Heating greenhouses.—Heating devices for the greenhouse are of various kinds. Greenhouses of the better class are now almost invariably heated with steam or hot water, or with a combination of the two. Pipes from a boiler located beneath the floor level extend nearly horizontally about the house, below the benches, returning to the boiler; or the main feed pipe extends overhead to the farther end of the house, where it connects with a system of return pipes beneath the benches. Where the pipes need to make many turns, steam is usually more satisfactory than hot water.

368. The propagating-bed.—A certain part of the greenhouse is usually set apart for propagating plants from cuttings. The propagating-bed is made upon the ordinary greenhouse bench, directly over heating pipes. To furnish the bottom heat (362), the space beneath the

bench is boxed in with boards. Horizontal doors are, however, provided, which may be opened when it is desirable to allow a part of the heat to pass directly into the house. The floor of the bench should not be so tight as to hinder drainage.

In large commercial establishments, entire glass houses are often devoted solely to propagation. Sometimes lean-to houses are built for propagation, on the north side of a wall, where direct sunlight is cut off.

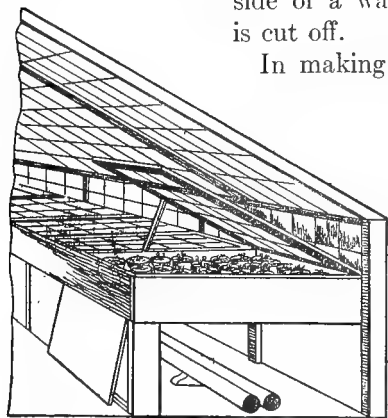

FIG. 99. — Propagating-bed covered with glazed sash.

In making the propagating-bed, a thin layer of sphagnum moss is usually spread over the floor of the bench and covered to a depth of two to four inches with well-packed, clean, rather coarse sharp sand, or other material which will not retain an excess of water if the proper provision is made for drainage.

Sometimes the whole bed is made of moss. Sand is most used because it is as a rule readily obtained, but it needs to be selected with care, as it often contains injurious mineral matters. Sand found along the borders of fresh-water streams or lakes may generally be used without washing, but that dug from sand pits should in most cases be exposed to the air for a few weeks, and then be thoroughly washed before being employed for cuttings. It should be relatively free from

organic matter, as decaying material in the sand favors the development of cutting-bench trouble. The same sand should be used for but one lot of cuttings, as a rule, for it is liable to become infested with fungi that may work havoc with cuttings placed in it.

369. Methods of controlling humidity. — Where moisture needs to be controlled with especial care, as in propagating delicate plants from green cuttings, or in herbaceous grafting (393), the planted cuttings or the grafted plants are often covered with bell-jars. To guard against sudden fluctuations in temperature, a larger bell-jar is sometimes placed over a smaller one. By means of a bell-jar with a tight-fitting ground plate, evaporation may be wholly prevented from cuttings or plants, if desired. Propagating-beds are often covered with glazed sash, in addition to the glass roof of the house, to assist in maintaining a moist atmosphere about the cuttings (Fig. 99).

370. Propagation by cuttings from dormant plants. — For convenience, we separate propagation by cuttings into two divisions, viz., propagation by cuttings from dormant and from active plants. The requirements of these two classes differ in some respects.

We have seen that plant processes may not be wholly suspended during the dormant period (176). This is true not only of the plant as a whole, but also of detached parts of the plant, if they are protected from evaporation. If cuttings are taken from a plant in autumn and stored during winter in a moist place of moderate temperature, the cut surfaces will partially callus over (72), and the formation of roots or buds may commence before spring.

When new growing points must be developed before the cuttings can form a plant, as with cuttings of the

stem and roots of many species, cuttings of dormant plants are preferably made at the beginning of the dormant period, *i.e.*, in autumn, and placed during winter under conditions favoring the formation of new growing points.

371. The storage of cuttings. — Cuttings should be stored in a place sufficiently moist to prevent loss of water by evaporation, and warm enough to favor moderate root growth but not warm enough to encourage leaf development. Cuttings with ready-formed buds must be kept cool enough to prevent growth of these. Root growth may proceed to some extent at temperatures too low to excite the buds. These conditions are usually fulfilled by covering the cuttings in damp sawdust, sand or loose loam, and storing them through the winter in a moist, moderately cool cellar, or by burying them in the open ground beneath the frost line. In mild climates the latter plan is often preferable. Stem cuttings (373) of plants that do not root freely from the stem are frequently buried with the proximal end (115) uppermost. This gives them, to some extent, the advantage of bottom heat (362), since the surface layers of the soil are first warmed by the sun in spring.

Cuttings stored in the ground over winter should be taken up and planted in spring before the buds expand.

Cuttings of evergreen plants should not be buried, as this would destroy the leaves, without which they rarely form roots. Cuttings of these plants are usually made in autumn and planted at once in boxes of sand, which are kept for a time in a light, cool place, as a cool greenhouse, until the growing points of the roots have formed, after which they are removed to a warmer location.

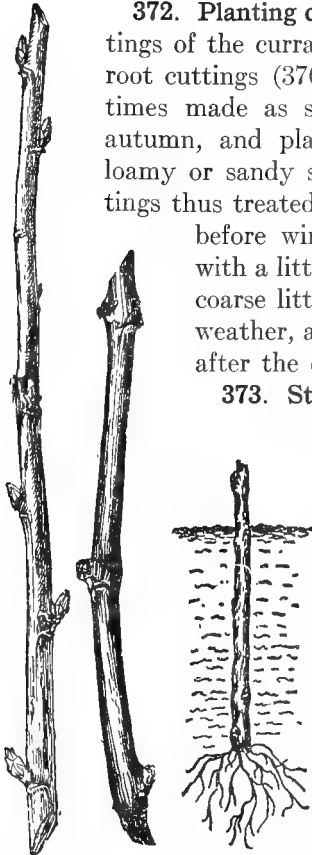

FIG. 100. FIG. 101. FIG. 102.

FIG. 100. — Stem cutting of currant.

FIG. 101. — Stem cutting of grape.

FIG. 102. — Currant cutting rooted.

372. Planting cuttings in autumn.—Stem cuttings of the currant and other hardy plants, and root cuttings (376) of the blackberry, are sometimes made as soon as the wood is mature in autumn, and planted at once in well-drained loamy or sandy soil in the open ground. Cuttings thus treated often commence to form roots before winter. They should be covered with a little earth and mulched with some coarse litter on the approach of freezing weather, and should be shaded for a time after the opening of spring (Fig. 64).

373. Stem cuttings.—Cuttings from

dormant stems usually form roots more promptly if the proximal end is cut off shortly below a node (115). (See Figs. 100, 101 and 102.) In certain plants, as many of the conifers, cuttings root more promptly when cut with a heel, *i.e.*, with a small portion of the wood of the previous year at the base. The very short internodes at the junction of the two seasons' growth appear to favor the emission of roots. Some varieties of the grape root more readily when a short section of the parent branch is removed with the cutting, forming a mallet or T-shaped cutting (mallet cuttings).

The cut forming the distal end of the cutting (115) is preferably made somewhat above a node, in order that the bud may not lose an undue amount of moisture by evaporation from the adjacent cut surface.

Cuttings of certain plants that do not readily form roots when made in the ordinary way may be induced to do so by "ringing" the branch from which the cutting is to be made (428), just below a node at about midsummer. Callus will then form at the upper edge of the ring (79), and food will be stored in the stem immediately above it. In autumn the branch may be severed just below the ring and a cutting made, of which the base shall include the callused part, and which may be treated in the usual manner.

374. Length of stem cuttings. — The proper length for stem cuttings depends upon the conditions under which they are to be grown. Cuttings containing only one bud often root freely and form vigorous plants in the propagating bed, where heat and moisture may be readily controlled. Such short cuttings, however, are seldom used except when cutting wood is scarce. Cuttings intended for planting in the open ground are preferably made at least six inches long.

375. How to plant stem cuttings. — The general rules given for the planting of seeds apply with nearly equal force to cuttings of the stem (344). Single-bud cuttings should be planted with the bud facing upward, and one-half to three-fourths inch deep, in order that the developing bud may readily reach the surface. Cuttings of more than one bud may be placed upright or at an angle, at such a depth that the bud at the distal end (115) is about on a level with the surface. In cuttings of shrubby plants desired to produce a single stem, the central

buds should be rubbed off before planting, leaving but one or two buds at the distal end (Fig. 100).

376. Propagation from cuttings of the root. — Plants that naturally sucker from the root (347) and some others may be propagated from short pieces of the root (root cuttings). For this purpose roots of about the thickness of a lead-pencil are commonly cut into pieces one to three inches long (Fig. 103), as soon as growth ceases in autumn, and packed in boxes with alternate layers of moist sand or moss. The boxes are preferably stored in a cool cellar where they may be examined from time to time during winter; the sand or moss should be moistened



FIG. 103. — Root-cutting of blackberry.

when it appears dry. Root-cuttings of different varieties of the same plant often require different degrees of temperature to induce the formation of callus and buds, hence

the boxes should be frequently examined, particularly toward spring, in order that those in which the cuttings are backward in starting may be placed in a higher temperature. Thus treated, root-cuttings of many hardy plants, such as the plum, raspberry, blackberry, juneberry and the like, often form both buds and rootlets by spring, so that they may be planted directly in the open ground. Those of more tender species, such as the bouvardia, geranium and the like, will not start to the same degree, unless placed in the propagating bed toward spring and given bottom heat.

Root cuttings should be planted shallow, usually not more than one-half to three-fourths of an inch deep, in order that the developing bud may soon reach the light; otherwise, as in too-deeply planted seeds, the reserve

food may be exhausted before the shoot reaches the surface. When planted in the open ground (372), the soil should be made very fine and carefully pressed about the cuttings; if the weather is warm and dry, shading (Fig. 64) and watering will be necessary.

377. Propagation by cuttings from active plants (green cuttings, slips). — Nearly all plants may be propagated from green cuttings. A succulent cutting of nasturtium with its leaves intact, and with its proximal end immersed in fresh well- or spring-water, will for a time absorb sufficient of the liquid to make good the loss from transpiration (74). So long as the water remains fresh and the tissues of the stem are unobstructed, the water thus absorbed will answer the same purpose to this cutting as if it had been absorbed by the roots. Food formation (58) will continue, and the growth current (79) will transport the prepared food from the leaves into the stem and in the direction of the roots. No roots being present, however, the growing points of roots will form at the base of the stem, and we shall soon have a rooted cutting. Not all plants, however, root freely in water, possibly owing to the insufficient supply of oxygen.

With very few exceptions, of which the greenhouse smilax (*Asparagus asparagiodes*) is one, cuttings of the succulent growth of the stem, with a certain amount of healthy leaf surface intact, will develop roots in all plants, under proper conditions of humidity and temperature; hence propagation from green cuttings is a very common and expeditious method of multiplying plants. The healthy leaf surface, capable of preparing food, is a very important part of a green cutting, because the stem is less abundantly supplied with reserve food during the growth period than during the dormant period (184).

Since the presence of leaf surface upon the cutting greatly promotes transpiration (74), propagation from green cuttings is scarcely practicable in the open air. Bottom heat (362), with a comparatively low air temperature, is especially important with green cuttings, in order that the food prepared in the leaves may be devoted to the formation of roots. A small leaf surface on the cutting is generally prefer-



FIG. 104. — Rooted cutting of coleus.

able to a larger one; in many plants, a portion of a single leaf is sufficient. The leaf surface should in no case be permitted to wilt; hence the cuttings should generally be sprinkled with water as soon as made. Figs. 104 and 105 show forms of greenwood cuttings.

378. Care in making green cuttings. — Especial care is necessary in propagating plants from green cuttings. In planting the cuttings, the material of the propagating bed should be put in close contact with the stems, and no leaves of the cuttings should be covered. Since roots cannot form without oxygen, the bed must not be so freely watered as to exclude all air. Transpiration should be reduced by sheltering the cuttings from the direct rays of the sun. Movable screens, used during sunshine only, are preferable to whitening the glass, which causes too much shade when the sun is not shining.



FIG. 105. — Cutting of chrysanthemum.

Damping-off, a much-dreaded disease causing cuttings

to rot at the surface of the bed, is promoted by excessive heat, over-watering or insufficient light or air; also by decomposing organic matter in the material of the bed. Affected cuttings should be promptly removed and the trouble corrected.

Green cuttings should be potted as soon as roots form, which may be detected by their foliage assuming a bright color. They should first be placed in small pots, and until they have commenced growth in these, should be treated precisely as before they were potted.

379. Kinds of green cuttings. — Propagation by green cuttings includes three divisions, of which the requirements differ in some respects, viz., propagation by cuttings of herbaceous plants, of woody plants and of the leaf or parts of the leaf (leaf cuttings).

380. How to make green cuttings of herbaceous plants. — In herbaceous plants roots develop most readily from the younger and more succulent parts of the stem. Bend the shoot near its terminus in the form of a U, and then press the parts together. If the stem breaks with a snap, it is in the proper condition to root promptly; if it bends without breaking, it has become too hard. Cutting below a node (115) is not essential to the formation of roots in herbaceous plants.¹

While the propagating house or hotbed is necessary to the extensive multiplication of herbaceous plants by green cuttings, the amateur may readily propagate a limited number of plants by the so-called "saucer system." The cuttings may be placed in glazed saucers

¹ In a few plants, such as the dahlia, the presence of a dormant bud at the crown is essential to the development of the stem the succeeding year. Cuttings of such plants should therefore be made below a node, if the roots are desired for future use.

containing sand that should be kept saturated with water. The saucers may be set in any warm, well-lighted place, such as the window of a living room. The stems being in this case in contact with the water in the bottom of the saucer, the cuttings require less shading than those in the propagating bed.

381. How to make green cuttings of woody plants. — Cuttings of woody plants are preferably made of harder growths than those best suited to herbaceous plants.

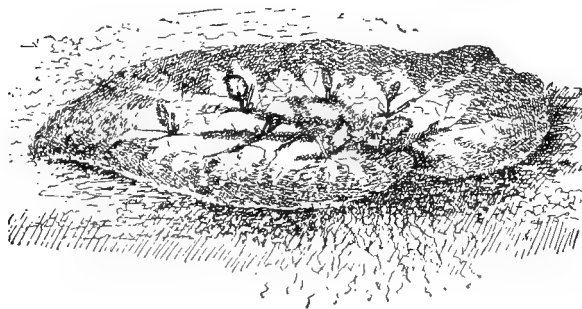

FIG. 106. — Leaf of begonia on surface of propagating bed, forming young plants.

They should be selected from young shoots of medium size and from half-mature wood, and should generally contain from two to three nodes, though where the material for cuttings is scarce, single buds may be used in many plants. The base of the cutting is preferably cut shortly below the node, but this is not essential in all plants.

In this kind of propagation a mild bottom heat is helpful; though it is sometimes carried on during the summer months without artificial heat.

382. Propagation by leaf-cuttings. — A considerable number of plants, including the bryophyllum, begonia

(Fig. 106) gesnera and others, readily develop growing points of the stem and roots upon their leaves, a fact often turned to account in propagating these plants. Well-matured leaves, with the principal nerves cut across on the under side, are held in close contact with the surface of the propagating bed by pegging or by light weights, or the leaf may be cut into pieces, which may be placed in the propagating bed and treated as ordinary green cuttings (378).

The leaves of the bryophyllum form rootlets and buds from the notches on their borders wherever these chance to come in contact with a moist medium.

CHAPTER XV

PROPAGATION BY GRAFTING

A **CUTTING** is placed in the soil or other medium. A **graft** or **cion** is placed in another plant, with the expectation that it will grow there.

383. Grafting consists in placing together two portions of a plant or of different plants, having a living cambium ring (68) in such a way that their cambium parts are maintained in intimate contact. Plants that do not have a cambium ring cannot be grafted successfully. If the operation is successful, growth will unite the two parts (69), and plant processes will go on much as if the parts had never been separated. The union usually takes place most rapidly when the cambium cells are in the state of most rapid division, *i.e.*, when growth is most vigorous.

The more intimate the contact of the cambium in the parts brought together, and the less injury their cells sustain in adjusting them, the more likely are they to unite.

The plant that it is desired to change by grafting is called the **stock**, and the part designed to be united to the stock is called the **cion** (**scion**), **graft** or **bud**.

Although the tissues of two plants of differing character often unite in grafting, each of the united parts almost always retains its individual character. For ex-

ample, if one or more buds of the Ben Davis apple are caused to unite by grafting with the stem of a Baldwin apple, the parts that grow thereafter from the Ben Davis buds, though nourished by sap that has passed through the Baldwin roots and stem, with rare exceptions, continue to be Ben Davis, while the parts that grow from the Baldwin stock continue to be Baldwin. To this fact is due the chief value of grafting, viz., it enables us to change the character of a plant.

384. Objects of grafting. — Grafting enables us

(a) To change a plant of an undesirable variety into one or more desirable ones;

(b) To preserve and multiply plants of varieties that cannot be preserved or multiplied by growing them from their seeds;

(c) To hasten the flowering or fruiting of seedlings grown with a view to improving varieties;

(d) To change the size of trees, so as to dwarf them;

(e) To restore lost or defective branches;

(f) To adapt varieties to special soils;

(g) To save girdled trees;

(h) To avoid insect injury to the trunk or root, as in grafting the peach on the plum, or the European grape on the American.

385. The plants that unite by grafting. — In plants capable of being grafted, the following statements will ordinarily be found true: Different varieties of the same species (21) almost always unite by grafting; examples, the Ben Davis and Baldwin apples, the Bartlett and Seckel pears.

Plants of different species of the same genus (21) often unite by grafting; examples, the peach unites with the plum, many pears unite with the quince, the tomato unites with the potato.

Plants of different genera in the same family or order

(21) sometimes unite by grafting; examples, the chestnut unites with the oak; the pear unites with the thorn.

Plants belonging to different families rarely unite by grafting. The oak and walnut and the fir and linden have been grafted.

The apparent resemblance of two plants of different species is not always evidence that they will unite by grafting, *e.g.*, the peach and apricot, though resembling each other in many respects, do not readily unite by grafting, but both unite freely when worked upon the plum, though the latter apparently differs from both the peach and apricot more than these differ from each other.

Many plants unite freely when grafted in one direction, that fail to unite when worked in the opposite direction; *e.g.*, many cultivated cherries united freely when worked upon the mahaleb cherry, while the latter fails to unite when worked upon any of the cultivated cherries; many pears unite freely when grafted upon the quince, but the quince does not freely unite when worked upon the pear. The only sure way of determining what species may be united by grafting is by trial.

These principal kinds of grafting are in use, *viz.*, cion-grafting, budding and approach grafting.

386. Cion-grafting is used in grafting on roots (root-grafting) and very often in grafting on the stem, especially on large trees. The cion is a portion of the dormant stem, of the variety it is desired to propagate. It should generally be of the preceding season's growth and should always contain one or more healthy leaf-buds (131). Flower-buds are occasionally used, but should be avoided except in special cases. It is probably best to cut cions from trees known to be fruitful. Cions are usually cut

in autumn or during mild weather in winter or early spring, and are commonly stored, until needed for use, in a cool cellar packed in moist sawdust, moss or leaves. In climates of severe winters, they should always be cut in autumn. Cions should not be kept so moist as to cause swelling of the buds or the formation of a callus (72), nor so dry as to cause shriveling.

In cion grafting the proximal end of the cion (115) is joined to the distal end of the stock, if the stock is a stem, or to the proximal end, if it is a root, in such a way that the cambium layers of the two coincide in at least one place. Cion grafting in the open air is usually most successful when performed just before or during the resumption of active growth in spring, and the cion is thought to unite more readily if in a slightly more dormant condition than the stock, possibly owing to its more ready absorption of water when in this state.

The joints made in cion grafting are generally coated with a thin layer of grafting-wax (387) or bound in grafting-paper, cloth or cord (308, 309), to prevent evaporation and to keep out water. Sometimes the whole exposed part of the cion is waxed. Figs. 107-121 show forms and methods of grafting.

387. Grafting wax. — To make grafting-wax for cleft-grafting (392), melt together four parts, by weight, of unbleached rosin, two parts of beeswax and one part of beef tallow; pour into water, and when sufficiently cool, work with the hands until the mass assumes a buff color; make into rolls and wrap with paraffined (waxed) paper to prevent the rolls from sticking together. Several other formulæ are in use. The hands should be greased before touching the wax to prevent sticking.

For whip-grafting (390), when waxed cord, cloth or

paper is used, the beeswax may be omitted from the above formula, or one-half more tallow may be added.



- FIG. 107. FIG. 108. FIG. 109. FIG. 110. FIG. 111. FIG. 112. FIG. 113.
 FIG. 107. — Grafting knife. This should be of excellent steel. The curve in the blade is not essential.
 FIG. 108. — Cion used for whip-, root- or cleft-grafting, one-fourth natural size.
 FIG. 109. — Seedling root, used in root-grafting, one-fourth natural size.
 FIG. 110. — Cion shaped ready for insertion, reduced nearly one-half.
 FIG. 111. — Portion of seedling root, shaped to receive the cion.
 FIG. 112. — The cion and portion of root, put together.
 FIG. 113. — The same as Fig. 109, wrapped with grafting paper.

388. Grafting cord is made by soaking balls of common wrapping twine in melted grafting-wax. Cord which is not waxed is frequently used also.

389. Grafting paper is made by painting thin manilla paper with melted grafting-wax. For painting, the paper is preferably spread out on a board of the exact size of the sheet; to prevent too rapid cooling of the wax the board should be heated. The wax should be heated hot enough to spread easily, but not so hot that it is absorbed by the paper. Thin muslin or calico is often used instead of paper.

Grafting paper and grafting cloth should be stored in a cool, moist place to preserve their adhesiveness.

390. Tongue-grafting. — Many kinds of cion grafting slightly differing in details have been described, but the more important are tongue-grafting, cleft-grafting and side-grafting.

In tongue-grafting (whip-grafting) the cion and stock are both cut off with a sloping cut, about an inch long, after which a tongue is formed on each by splitting the wood longitudinally a short distance (Figs. 110, 111). The cion is best cut behind a bud, as shown.

In joining, the tongue of the cion is inserted into the split of the stock, so that the cambium line of the cion and stock (68) coincide on one edge, and the two are crowded together with considerable force, after which the joint is wrapped with a narrow strip of grafting paper or grafting cloth (389), or wound with waxed or unwaxed cord.

Tongue-grafting is generally used when the stock is little if any thicker than the cion. It is much used by nurserymen in certain localities in grafting the apple and some other fruits upon roots (root-grafting, 391).

Tongue-grafting is also considerably used in some climates of severe winters, in top-grafting or "top-working" apple trees in the nursery, in order to give certain slightly-tender varieties the benefit of an especially hardy stock. This grafting is performed on two- or three-year-old trees, that have been grown from root grafts. The trunk is cut off at the height it is desired to form the head of the tree, and a cion of the variety to be propagated is inserted; or several cions are inserted in as many branches. The latter method, while more expen-

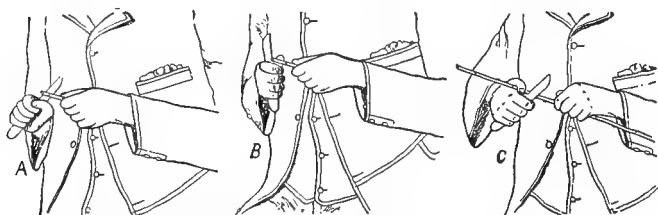

FIG. 114. — Shaping the cions for root-grafting. *A*, making the "long cut"; *B*, cutting the "tongue"; *C*, cutting off the cion. These positions, and the movements they indicate, are adapted to rapid work.

sive, has the advantage of giving to the top-grafted trees the branch formation of the stock, which is sometimes important.

As growth starts on the top-grafted trees, shoots that push out from the stock should be rubbed off to prevent them from robbing the cions of nourishment.

391. Root-grafting is commonly performed in-doors in winter. The stocks are small trees, grown one or two years from seed (seedlings). These are dug in autumn, and stored as recommended for cions (386). When ready for grafting, the roots are washed and trimmed by cutting off the larger branch roots, after which the stem

is cut off at the crown, and the end of the root (115) is shaped as directed above (390). It is then cut off two or three inches down, and the remaining root, if sufficiently thick, is shaped for another stock. Three or four stocks are sometimes made from a single root. As a rule, the stock should not be less than three-sixteenths inch in diameter, nor less than two inches long.

Some nurserymen prefer to make but a single stock from one root ("whole-root" grafts).

Different nurserymen cut the cions for root-grafts from two to six inches long. In climates subject to drought in summer and severe freezing in winter, the longer cions are more satisfactory, since they permit the stock to be covered to a greater depth, and encourage rooting from the cion, which is sometimes regarded as an advantage.



FIG. 115. — Grafting chisel for making the cleft in cleft-grafting. The point at the left is for holding the cleft open during insertion of cions. The projection above is for driving this point in or out; one-fifth natural size.

Root-grafts should be stored until the time for plant-out, as directed for cions (386).

392. Cleft-grafting is generally employed when the stock is considerably thicker than the cion. The cut-off end of the stock is split across its center, with the grafting-chisel (Fig. 112), and the proximal end of the cion (115), which is cut wedge-shaped and a little thicker on one edge than the other, is so inserted into the cleft that the cambium of the thicker edge of the cion forms a line with the cambium of the stock (Figs. 116, 117, 118). Success is promoted if the wedge-shaped portion of the

cion contains a bud on its thicker edge. When the stock exceeds an inch in thickness, two cions are usually inserted (Fig. 117), to increase the chances of success. The elasticity of the stock should exert sufficient pressure to maintain very close contact between it and the cion; otherwise it should be tightly bound with cord or raffia (393). The cions should contain at least one bud beyond the end of the stock. The wedge-shaped cut is usually made about one inch long, and the cion should be inserted into the



FIG. 116.



FIG. 117.

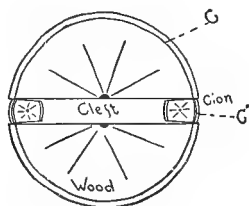

FIG. 118.

FIG. 116. — Cion shaped ready for insertion in cleft.

FIG. 117. — Cions inserted in cleft, ready for waxing.

FIG. 118. — Cross-section in Fig. 113 (after Maynard). *C* cambium layer of stock; *C'* cambium layer of cion. The cambium layers of the outer edge of the cion should form a continuous line with those of the stock. The cion is made a little thinner at its inner edge to permit the pressure of the stock to be exerted at the outer edge.

cleft as far as the length of the wedge, after which all the exposed wounded surfaces, including the distal end of the cion, should be coated with grafting-wax (387).

Cleft-grafting is most used in top-grafting old trees. Four to six of the main branches, located as nearly equidis-

tant as possible (Fig. 119), are selected for grafting, and it is desirable to graft these rather near to the top of the trunk.

Branches exceeding two inches in diameter should not, as a rule, be grafted. About half of the top of the tree should be cut away just before the grafting, leaving some branches to utilize a part of the sap. The more or less horizontal branches should generally be selected for grafting, and in these the cleft should be made horizontally, to give the two

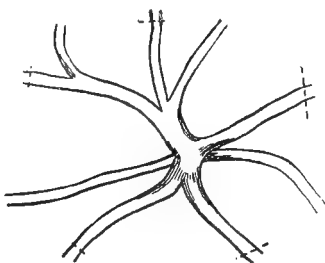

FIG. 119. — Branches of tree to be top-grafted, as seen from above, showing where to insert the cions to make a well-formed head, *i.e.*, at the dotted lines.

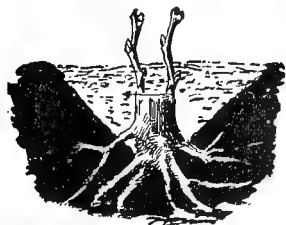

FIG. 120. — Cleft-graft in trunk of old grape vine. The cions are usually inserted below the surface of the ground in grafting the grape, and no wax is used.

cions inserted an equal opportunity for growth. If both of the cions in a branch grow, the weaker one should be pruned off later. As growth starts, shoots from the stock must be rubbed off (390).

The spring following the top-grafting, all or a part of the branches left on the stock at grafting should be pruned off to encourage growth of the grafts. If the tree is large and of a vigorous variety, it is wise to leave a part of these branches until the second spring.

393. Side-grafting is chiefly practiced with plants in leaf, under glass. The cion is joined at the side of the

stock, which is usually not cut off, and is secured in place by wrapping tightly with grafting cloth or raffia. Three slightly different methods are in use.

(a) A shaving of bark, thick enough to reach into the cambium layer, is removed from the side of the stock by making a long vertical cut and a short transverse cut at the base, and to this cut surface the cion is carefully fitted, and bound with raffia. This method is called veneer-grafting.



FIG. 121. — Side-graft inserted, ready for tying.

(b) A sloping cut is made rather deeply into the sapwood of the stock, into which the cion, after being tapered at its base to the form of a wedge, is inserted (Fig. 118), and the parts are then held closely together by binding with raffia. This method is generally employed in herbaceous grafting, as with the potato, tomato and the like. It is also much used in grafting evergreens under glass, and occasionally in grafting outdoor nursery

trees. In the latter case, a coating of grafting-wax is usually substituted for the tying.

(c) A short, transverse incision is made, and immediately below this, a somewhat longer, vertical cut — the two cuts, which are just deep enough to reach through the bark, forming a T (Fig. 121). The cion is then cut off with a long, sloping cut, and the point inserted, the cut surface inward, beneath the two lips of bark formed by the T-cut, after which the cion is crowded downward until its cut surface is in contact with the cambium layer of the stock, when the juncture is bound with raffia.

394. Budding is now extensively employed in propagating fruit trees, roses and the varieties of deciduous

ornamental trees and shrubs. A (usually dormant) leaf-bud, with a small portion of surrounding bark (Fig. 123), is placed in contact with the cambium layer of the stock. Budding may be successful whenever the cells of the cambium layer are in a state of active division, as indicated by the ready separation of the bark from the wood. In climates



FIG. 122.



FIG. 123.

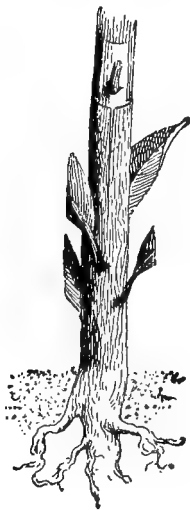

FIG. 124.



FIG. 125.

FIG. 122. — Shoot containing buds. The white spaces about the buds indicate the amount of bark to be cut off with the bud. The shoot is inverted for cutting the buds.

FIG. 123. — Bud cut off, ready for insertion.

FIG. 124. — Bud partially inserted between the lips of the stock.

FIG. 125. — Bud inserted and tied.

having severe winters, budding is most satisfactory when performed near the end of the growing season and with fully matured buds, in order that the buds may not expand until the following spring; thus the shoots growing

from the inserted bud will have the whole season for growth and maturity. Figs. 122-129 show forms and practices in budding.

With plants that unite freely and with the stock in the proper condition,

395. Success in budding depends upon (a) A fresh condition of the buds; these must not be in the least shriveled from dryness. (b) The proper removal and insertion of the bud; the growing point of the latter (66) must not be injured. If this comes out, leaving the bud-scales partially hollow, the bud will not grow, even if properly inserted. The bud should be inserted promptly to avoid loss of moisture. (c) The proper wrapping of the wounded bark to prevent evaporation and exclude moisture. The ligature should not cover the bud. (d) The removal of the ligature after the union, to permit expansion of the stock. (e) The cutting off of the stock just beyond the bud, when the latter commences growth, to stimulate its development.

Two methods of budding are in common use, viz., T- or shield-budding and ring- or annular-budding.

396. T-budding. — In T-budding, which is the more common and expeditious method, a short shaving, containing a hard and plump bud, cut deep enough to reach through the cambium (Fig. 123), is inserted beneath the bark of the stock, as described for side-grafting (393).

The buds, which should be plump and mature, and of the variety it is desired to propagate, are taken from shoots of the current season's growth. These shoots ("bud sticks") (Fig. 122) should be cut the day the buds are to be inserted, and should be trimmed at once, and rolled in damp cloth, to prevent loss of moisture. The trimming consists in cutting off the leaves, saving a bit of the

leaf stem to serve as a handle while inserting the buds. The stocks, whether grown from seeds or from cuttings,



FIG. 126. — A lesson in budding. The left-hand student is cutting a bud; the central one is lifting the lips of the bark with the spatula of his budding knife; the right-hand student is tying the bud.

are usually of one or two season's growth. The lower branches of the stock are cut off up three inches or more from the ground, and a smooth place is selected for the bud, usually on the side least exposed to the sun's rays. With the budding knife, a T-shaped cut is made on the stock (393) about two inches above the ground. A bud is then cut from the bud stick, by inserting the blade of the budding knife about a fourth of



FIG. 127. — Man budding in nursery row.

an inch below the bud, at such an angle that the back of the blade nearly touches the bark of the stick. The blade is passed just behind the bud, touching the wood, but not removing much of it, and then turned a little, running

out about a fourth of an inch above the bud (Fig. 123). Often the knife does not run out, but the bark is cut off square, a quarter of an inch above the bud, as indicated in Fig. 122.

With the spatula of the budding knife (397), the lips of bark in the angles of the T-cut are loosened from the wood, when the bit of bark bearing the bud is slipped down behind them (Fig. 124), with the bud pointing upward,

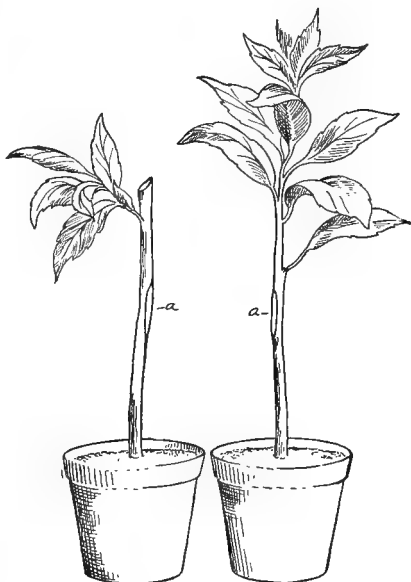

FIG. 128.

FIG. 129.

FIG. 130.

FIG. 128. — Budding knife with ivory spatula on the end opposite the blade.

FIG. 129. — Budding knife made from erasing knife by rounding the edge at *A*.

FIG. 130. — Two plants prepared for approach-grafting. The cut surfaces, *a, a*, are to be placed together and bound.

until the top end of the bit of bark is just below the horizontal cut of the T. Some budders do not use the

spatula, but raise the lips of bark with the blade of the budding knife. The center of a strip of moistened raffia is then applied to the stock just below the inserted bud; the ends of the strip are crossed on the opposite side of the stock, brought forward and again crossed just above the bud, thus covering the horizontal cut of the T. The ends of the raffia are then brought behind the stock, tied in a half knot, and drawn moderately tight (Fig. 125), pressing the lips down snugly about the bud, which now protrudes between the lips.

If the bud "takes," it will unite with the stock in a few days. The raffia should be taken off in about ten days, by cutting it on the back side of the stock, to enable the latter to expand by growth.

397. The budding knife should contain a blade of good steel, shaped as indicated in Fig. 128, and a round-edged spatula for lifting the bark. The spatula is better placed on the back of the blade, as shown in Fig. 129.

398. Ring-budding is used to some extent in the propagation of thick-barked plants, such as the hickory and magnolia. A section of bark is removed nearly or entirely around the stock, and a similar section, containing a bud from the variety it is desired to propagate, is fitted to its place and snugly bound with raffia. Ring budding is oftener performed in spring than later in the season.



FIG. 131. — Two plants bound together for approach-grafting.

399. Approach-grafting is now seldom employed, except in a few plants that unite poorly by other methods. It is only possible between two plants in close proximity, or between parts of the same plant, since the cion is not severed from the parent until it has united with the stock. The plants are nourished by their own roots until the union takes place.

Approach grafting is performed during or just previous to the growing season. The parts are held in contact by binding them with raffia; the juncture should also be waxed if the work is done in the open air.

Two methods of approach grafting are in use :

(a) A shaving reaching into the cambium layer is removed from both stock and graft on the sides toward each other (Fig. 130), and the cut surfaces are brought together and closely bound until they unite (Fig. 131), after which the cion is cut off below, and the stock above, the union.

(b) The top of the stock is cut off with a long sloping cut, preferably behind the bud, and the cut surface of the remaining part is inserted beneath the bark of the graft, as described in side grafting (393), except that the T-cut is inverted, and the stock is inserted from beneath.

The graft is cut off below the point of union when the parts are fully united.

In both these methods the cion should be severed gradually to avoid a check to the growth.

CHAPTER XVI

TRANSPLANTING

THE seed or the cutting is not always planted or set in the place where the plant is to grow. We may therefore consider what is to be done in moving and removing it.

400. Transplanting consists in lifting a plant from the medium in which its roots are established, and in replanting the latter in a different location. Transplanting is a violent operation because the younger roots with their root-hairs that absorb the greater part of the water required for the plant (101) are, as a rule, largely sacrificed in the lifting process. The water supply, so vitally important to the plant (62), is thus greatly curtailed until new root-hairs can be formed.

Vigorous plants are generally better able to endure transplanting than feebler ones, because they can sooner repair the damage done to their roots. It follows that plants endure transplanting with less facility as they advance in age beyond the period of greatest vigor (9).

401. Time to transplant. — The most favorable time for transplanting, in the case of plants that live more than one year, is during the dormant period, because growth processes are then least active, and comparatively little water is needed. In countries having mild winters, the most favorable time for transplanting is generally at the beginning of the dormant period, provided this comes

at a moist season of the year. The roots will then have time to slowly callus over their wounds and to form new rootlets, and thus be prepared for active growth in spring. But in countries of severe winters, where the roots are largely frozen in the soil for two or three months, and in countries in which the autumn is generally dry, spring is, as a rule, the more favorable season for transplanting.

Trees that have been long exposed to cold, drying winds and have thus suffered depletion of water from their buds and branches, are better not lifted until the buds begin to swell. This is especially true of evergreen trees in severe climates. Being always in leaf they require more careful treatment than deciduous trees.

We shall consider transplanting under three divisions, viz., (a) lifting the plant; (b) removing the plant; and (c) replanting the plant.

402. Lifting the plant. — The object to be obtained in this operation should be to remove the roots from the soil with the least possible damage consistent with reasonable economy of time and labor. Plants in low vigor should receive especial care in this respect. Very young plants, such as tobacco, cabbage, lettuce and the like, grown thickly in the seed-bed, are often pulled from the soil with the hands. In this case, the soil of the bed should first be saturated with water, in order that the roots may be broken as little as possible, and may come up with more or less adhering soil. It is generally preferable to grow such plants in drills rather than broadcast. This enables them to be drawn from the soil with less damage to their roots.

Trees and shrubs sufficiently grown for their final planting out should be more carefully handled. If it is necessary to cut off the main roots, the farther from the

trunk this is done, the better for the tree, and the spade used should be kept as sharp as possible. The roots should not be barked, mangled or split by the digging tools, as is so often done with nursery stock. Tree-digging machines are now much used by the larger nurserymen.

403. Lifting large trees. — Trees considerably larger than nursery sizes are best lifted when the ground is frozen about their roots. A trench may be dug about the tree before the ground freezes, deep enough to permit the severing of the main roots, and a hole for the reception of the cylinder of earth left within the trench should also be dug at the place to which it is desired to remove the tree. This cylinder should be large enough so that the tree is left with abundant roots, or as large as can be removed with the apparatus at hand. When the ground is frozen to the proper depth, the tree may be tipped over by means of a rope and windlass, after which the cylinder of earth inclosing the roots may be pried up sufficiently to allow some low vehicle to be placed beneath it. The branches are usually permitted to drag upon the ground in removal, since the wounded parts may be cut off in the severe pruning necessary in planting large trees (409).

Large trees may be lifted or lowered to accommodate grading. A trench is dug round the tree, leaving a cylinder of earth intact about the roots. Soil is then removed from beneath one side of the cylinder below the roots and a block set under as a fulcrum. The top of the tree is then inclined toward the fulcrum by means of a rope, until the roots are lifted on the opposite side. If the tree is to be raised, soil is packed under the elevated roots, after which the top is tilted in the opposite direc-

tion, until the roots are lifted on the fulcrum side, when soil is placed under as before. This process is repeated until the tree has been lifted to the desired height. If the tree is to be lowered, earth is removed at each tilt.

404. Sacking the earth-inclosed roots is practiced in lifting and removing orange trees in California and may be profitably employed with other evergreens. A rather deep trench is dug at one side of the tree, and from this trench, the deeper roots are severed. The top earth is then removed down to the first lateral roots, when all the remaining large roots are severed at some distance from the trunk. The tree is next tilted to one side and a piece of burlap or matting is drawn beneath it, after which the matting is folded about the earth cylinder and well tied.

405. Removing the plant. — Plants with their roots out of the soil should be carefully protected from mechanical injury, from drying and from freezing. To insure such protection, plants to be transported any considerable distance should be packed.

Plants packed for transportation should be inclosed throughout, and the roots should be in close contact with some moist material, preferably bog moss. Straw is often used for this purpose and answers well for packing about the trunks and branches of trees, but it is inferior to moss for inclosing roots, as it is more liable to heat and does not so well retain moisture.

Herbaceous plants, such as the strawberry, cabbage, sweet potato and the like, may be packed in layers separated with moss, as follows: Over the bottom of the box, the width of which is about twice as long as the plants to be packed, and which has slatted sides, place a thin layer of damp (not wet) moss, and over this, place a layer

formed of a double row of the plants, with their roots at the center, overlapping a little, and tops toward the sides of the box (Fig. 132). Then put in another layer of moss and so on until the box is full, or the desired quantity is packed. The thickness of the layers will depend upon the time of year, the temperature, the distance to be transported and the kind of plants. The warmer the weather, the thinner should be the layers of plants, as a rule. When the top of the box is put on, the contents should be pressed sufficiently to prevent the plants from shaking out of place.

406. Puddling the roots of trees, *i.e.*, dipping them in a paste of soil and water, is much practiced by nurserymen and tends to prevent them from drying. The paste should be made with rather light, loamy soil and of the consistency of cream.

407. Bundling. — Trees are commonly bundled for transportation to economize space. For this purpose, a device resembling a sawbuck, with the arms cushioned with burlap or carpeting is very convenient. The trees are laid between the arms, with the roots placed evenly at one end. The stems are then drawn snugly together with a broad strap, after which they are bound with soft cord or with young and tender shoots of the osier willow (*Salix viminalis*). After bundling, the space between the roots should be filled with damp moss, and the whole mass

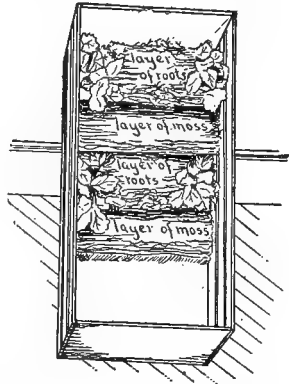

FIG. 132. — Packing: showing how plants should be packed for shipping.

of roots surrounded with the same material. If the distance to be transported is short, the mossed roots may

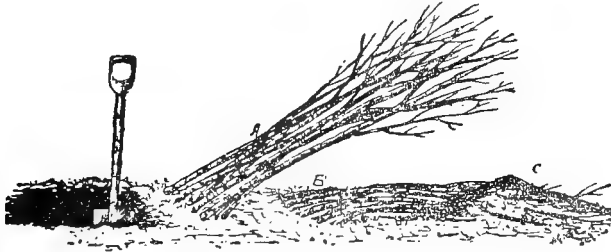

FIG. 133. — Nursery trees heeled-in to prevent drying. *A*, a short row of trees with only the roots covered. *B*, a row with their tops bent down and covered with earth at *C*. Sometimes the whole tops are covered. Trees should not be heeled-in in the bundles.

be sewed up in burlap or matting and the tops may be tied up in straight straw, or the whole bundle may be inclosed in burlap. If the distance is long, the bundle should be boxed, to more effectually prevent the tree from damage. The bundles may be packed very closely in the box without injury, provided they nowhere come in direct contact with it. Boxed or bundled trees, that cannot be shipped at once, should be stored in a cool, damp place.

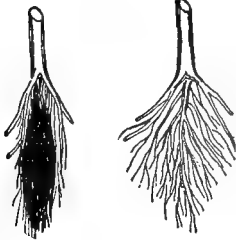

FIG. 134. FIG. 135.

FIG. 134. — Puddled roots of nursery tree.

FIG. 135. — The same washed, ready for planting.

408. Unpacking and heeling-in.

— Packed plants should generally be removed from their package as soon as they reach their destination. If they cannot be replanted immediately, they should be heeled-in. This con-

sists in removing them from their bundles and temporarily planting their roots in soil (Fig. 133). The roots should be well covered, and if at a dry season, they should also be mulched. To avoid mixing varieties, a separate row should be made of each sort.

Nursery trees that cannot be packed for shipment at the proper time are often lifted and heeled-in, to retard the starting of the buds.

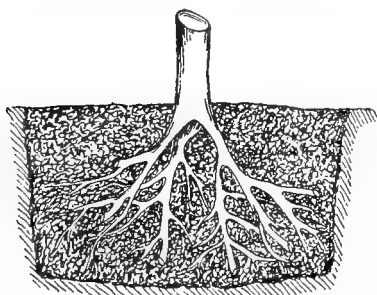

FIG. 136. — Roots of tree properly planted.

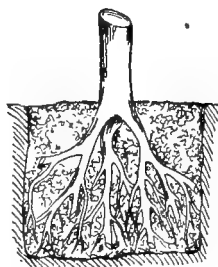

FIG. 137.— Same improperly planted.

409. Replanting. — The plant should be prepared for replanting by the following processes:

Washing the roots. — The “puddled” roots of nursery trees (406) are sometimes found inclosed at unpacking in a mass of mud that is so compact as to largely exclude the air (Fig. 134). The roots of such trees should be washed clean before replanting (Fig. 135).

Trimming the roots. — The roots of trees that have been broken or mangled in the lifting or transportation should be cut back to sound wood with a sharp knife. Fibrous rooted plants, as the strawberry, are much more readily planted when the roots are trimmed.

Reducing the top.—The buds of trees and shrubs should generally be reduced in number at replanting to correspond with the destruction of the younger roots during the lifting process; otherwise the water supplied by the roots may be insufficient to open the buds (62). This is best accomplished by thinning out and cutting back the branches. The branches that can best be spared should be removed (420), and the others cut back. Failure to properly reduce the top is a frequent cause of death or loss



FIG. 138.

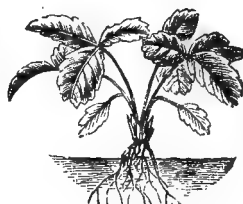

FIG. 139.

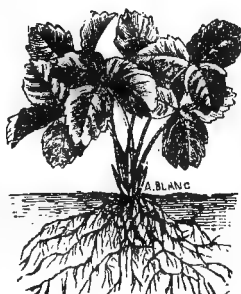

FIG. 140.

FIG. 138. — Strawberry plant too deeply planted.

FIG. 139. — The same planted too shallow.

FIG. 140. — Strawberry plant properly planted.

of vigor in transplanted trees. Small plants in leaf, such as the strawberry, cabbage and the like, usually endure transplanting better if their larger leaves are removed at replanting.

Wetting the roots just before replanting is quite important, as it favors intimate contact with the soil particles. Plants that have suffered from loss of moisture in transit should have their roots soaked in clean water for a few hours before replanting. Deciduous trees of which the bark is considerably shriveled may often be saved, if the

center of the buds is still fresh, by burying them in moist earth until the bark resumes its plumpness.

410. Replanting the roots. — The object to be attained in this operation is to place moist and well-aërated soil in contact with all of the roots of the plant. The roots should also be placed at about the same depth, and in nearly the same position that they grew before the removal. Fig. 136 shows the roots of a tree properly planted. The hole was dug sufficiently large so that the roots were readily placed in it without crowding, and the soil was so well worked in among the roots that it comes in contact with the whole surface. Fig. 137 shows the roots of the same tree improperly planted. The hole was dug so small that the roots were necessarily crowded out of their natural position, and the earth was thrown in so loosely that it comes in contact with only a part of the root surface. Distortion of the roots of trees and shrubs at planting may cause injurious deformities or galls, especially if accompanied by injury.

In planting trees of which the roots are not already inclosed in soil (403), the hands should be freely used to bring the soil in contact with the whole root surface,

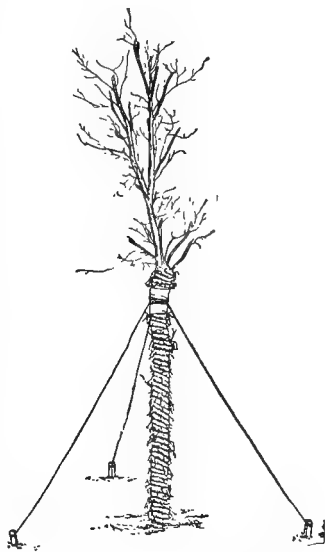

FIG. 141. — Large transplanted tree wound with hay rope and supported by wires.

and the earth should be moderately packed about the roots with the feet, or otherwise.

If the soil is dry, it is probably better to moisten it before placing it about the roots, rather than after, since we have then a better opportunity to judge of the quantity of water required, and the soil is less likely to settle away from the roots.

Trees of considerable size should generally be staked or



FIG. 142.

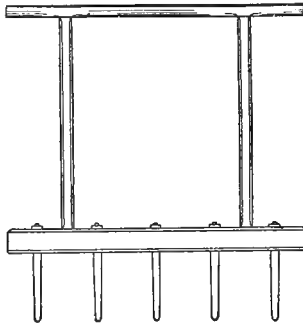

FIG. 143.



FIG. 144.

FIG. 142. — Flat steel dibber (one-sixth natural size).

FIG. 143. — Tool for planting root grafts and cuttings (much reduced).

FIG. 144. — Richards' transplanting tools, made by F. Richards, Freeport, N.Y.

otherwise supported after planting, to prevent shaking by wind (Fig. 141). Surrounding the trunk with poor-conducting material, such as hay, straw or canvas, tends to prevent damage from sun-scald (185), to which recently-transplanted trees are especially liable.

411. Devices for transplanting. — With young trees and plants, that possess abundant vigor, rapidity of planting is often of greater importance than the observance of precise rules. In this case, that method is

best which secures a given number of transplanted and vigorously-growing plants at the least cost. The transplanting devices shown in Figs. 142-144 aid greatly in accomplishing this end.

The dibber (Fig. 142) is perhaps, aside from the spade, the most valuable single tool for transplanting. It is used for opening the hole to receive the roots of small plants, such as cabbage, celery, onions and the like, and for pressing earth about the roots; it answers equally

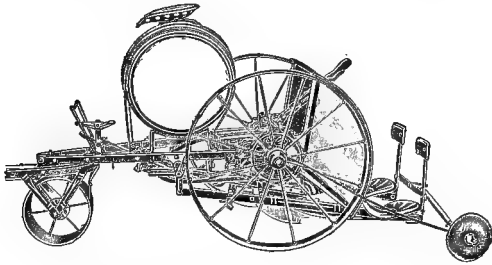

FIG. 145. — A transplating machine. Two operators or planters ride behind.

well for planting cuttings and root grafts. The manner of using it appears in Figs. 146 and 147. Fig. 143 shows a very convenient tool for planting root grafts and cuttings. It consists of five steel dibbers, attached equidistant in a line to a piece of scantling, with a handle affixed above. In using this tool, the operator crowds the dibbers into the soil with the foot, guided by a line. He then moves the frame to and fro until the holes are sufficiently opened, when he withdraws the dibbers by lifting the frame, and passes on to repeat the operation. A person follows inserting the grafts or cuttings, and

crowding earth about them with the ordinary dibber. Fig. 144 shows a set of transplanting tools, useful in removing a limited number of plants that are not closely crowded and that need to be carried but a short distance. They are especially useful for transplanting strawberry plants during summer and autumn. These tools enable the plant to be readily lifted with a cylinder of earth and replanted

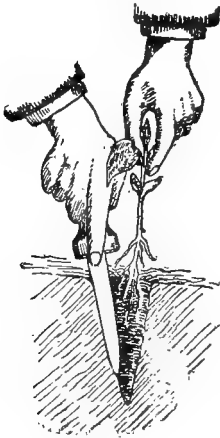

FIG. 146.

Showing manner of using the dibber in planting.

FIG. 146. — Inserting roots in the hole opened by dibber.

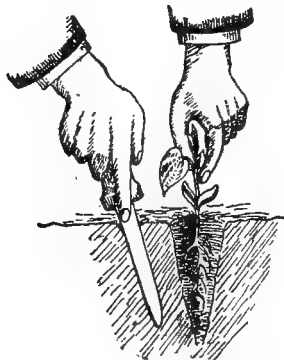

FIG. 147.

FIG. 147. — Pressing earth about roots with the dibber.

in a hole just large enough to receive the latter. Fig. 145 shows a successful machine for planting tobacco, cabbage and other low, herbaceous plants. It plants these as rapidly as two boys can deliver them to it in the proper position, and waters the soil about the roots at the same time.

412. Potting and shifting. — Potting is the act of planting plants in greenhouse pots. The pots should be

clean and are usually dipped in water before receiving the plants, until they have absorbed as much of the liquid as they will take without leaving any upon the surface. Rooted cuttings are generally potted in pots one and one-half to two inches in diameter, and the plants are changed to larger pots (shifted) as the roots require more room. Pots four inches or more in diameter are commonly filled



FIG. 148. — Potting. The workman takes the pot in his left hand, and at the same time a handful of potting soil in the right hand.



FIG. 149. — He places the soil in the pot, pressing it against one side with the right hand, while he picks up a plant with the left hand.

one-third full or less with pieces of broken pots (pots-herds) to insure abundant drainage, and these are often covered with a little sphagnum moss before putting in the soil. The soil used for potting should be of a sort that does not harden, “bake,” on drying, and should generally be liberally supplied with plant-food. Decayed sods from an old pasture, leaf mold, decomposed manure and sand, the whole mixed and sifted through a coarse sieve, form a good potting soil. The proportions

of the different ingredients used vary with different plants and the character of the soil supplied with the rotted sods. The soil should be moderately moist, and should be closely pressed about the roots. The details of potting are shown in Figs. 148 to 151.

Shifting is the changing of a plant from one pot to a larger one. Plants in small pots are generally shifted



FIG. 150. — Placing the roots of the plant against the soil in the pot with the left hand, he takes another handful of soil with the right hand.



FIG. 151. — He fills the remaining space in the pot with soil and presses it down with the thumbs, tapping the pot gently upon the bench in the meantime.

as often as their roots begin to crowd, and the shifting is continued as long as further growth is expected. When bloom is desired, the pots are permitted to become filled with roots (135).

The pots into which plants are to be shifted should be prepared as directed for potting. A little potting soil is placed in the bottom of the pot, or over the drainage material, after which the plant to be shifted is tipped out of its pot, by inverting the latter, placing the hand

upon the surface of the soil, to support it, and tapping the rim of the pot gently upon the edge of the potting bench.

If the soil is in the proper condition, it will readily slip out of the pot intact, after which it should be placed in the center of the new pot and the space about it filled with potting soil moderately pressed down. The roots of woody plants should not be covered much deeper than they grew before the shifting. (See Figs. 153, 154 and 155.)

413. Mulching the soil about transplanted plants (232) is very important in localities subject to drought. As a rule, it is wise to apply the mulch immediately after transplanting, but with trees transplanted very early in spring, it is better to defer mulching until the soil becomes sufficiently warm to promote root absorption (101).

Watering recently-transplanted plants requires discretion. As a rule, mulching is preferable to watering, but if mulching proves insufficient, watering is the last resort. In this case the soil about the roots should be saturated with water and should not be permitted to become dry again until growth starts. A hole may be made in the soil about the roots and kept filled with water until the liquid ceases to soak away rapidly, after which it should be occasionally filled until growth commences.

414. Shading plants transplanted in leaf, until the

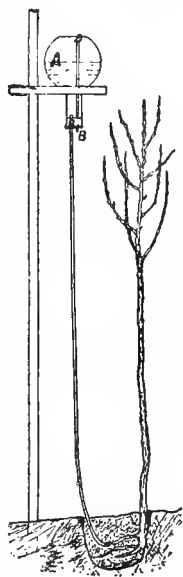

FIG. 152. — Device for starting growth in trees.

roots resume activity, is important (235). Evergreen trees and shrubs may often be shaded with barrels or boxes, or with boughs from other evergreen trees.

415. Tardy starting into growth after transplanting is usually evidence that the roots are not supplying sufficient water. In such cases, if other precautions have been observed, it is well to further reduce the top. Plants

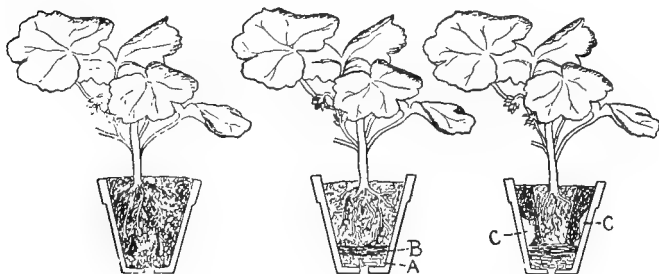

FIG. 153.

FIG. 154.

FIG. 155.

FIG. 153. — Potting. A poorly-potted plant. No provision is made for drainage; the pot is filled to the top with soil, leaving no space to receive the water; and the stem of the plant is not at the center of the pot.

FIG. 154. — A well-potted plant. A, potsherds; B, moss.

FIG. 155. — A poorly-shifted plant. C, open spaces due to insufficient pressing of the soil.

in this condition may sometimes be saved by wrapping the stem in oiled or rubber cloth to check loss of moisture, or with straw or moss which may be wet frequently till growth starts.

The device shown in Fig. 152 often causes recently-planted trees to start growth that seem likely to fail without it. It consists of a flask or bottle containing distilled or rain water, supported a few feet above the ground and connected by a rubber tube with the cut-off

end of a root, as shown. If the inverted flask is used, a short tube *B B* should extend through the cork and to near the bottom of the flask, to admit air.

Flower-buds should generally be removed from recently-transplanted plants (139).

CHAPTER XVII

PRUNING

ONE of the most important manipulations in the growing of plants is the work of pruning. It requires considerable skill; and the operator should also know the reasons and the results. Pruning is one of the cardinal operations in plant culture.

416. Pruning is the removing of a part of a plant, in order that the remainder may better serve our purpose.

The parts of plants, being less highly specialized than those of animals, may be removed with less damage to the individual than is possible with animals, except in the lowest types.

The word pruning, as commonly used, applies chiefly to the removal of parts of woody plants with the knife, shears or saw, but the operations defined below properly come under the same head.

Pinching is the removal with the thumb and finger of the undeveloped nodes at the terminus of growing shoots, in order to check growth.

Trimming or *dressing*, when applied to young nursery stock, is the shortening of both roots and stem, preparatory to planting in nursery rows. The roots are shortened to facilitate planting, and the stems are shortened to reduce the number of buds (409).

Topping is the removal of the flower stalk, as in to-

bacco, to prevent exhaustion of the plant by the formation of seed.

De-tasseling is the removal of the staminate flowers (tassels) of undesirable plants of Indian corn, to prevent pollination from them (150).

Suckering is the removal of shoots that start about the base of the stem, or in the axils of the leaves, as in Indian corn or tobacco. Its object is to prevent exhaustion of the plant by the production of needless shoots.

Disbudding is the removal of buds, to prevent the development of undesirable shoots or flowers.

Ringing is the removal of a narrow belt of bark about a branch, to obstruct the current of prepared food (138).

Notching is the cutting of a notch just above or below a bud or twig to modify its growth.

Thinning fruit is the removal of a part of the fruits upon a plant, to permit the remaining ones to attain larger size, and to prevent exhaustion of the plant by excessive seed production.

De-flowering or *de-fruited* is the removal of flower-buds or fruits to prevent exhaustion of the plant (139).

Root pruning is the shortening of the roots of plants in the soil, to check growth, or to stimulate the formation of branch roots nearer the trunk (104).

Sprouting is the removal of sterile shoots or water sprouts from the upper part of the grape vine.

417. The season for pruning. — The milder kinds of pruning, such as pinching and disbudding, may be performed whenever the necessity for them appears. But in perennial plants, severe pruning, such as the removal of branches of considerable size, is generally least injurious if performed during the dormant period. Since the

exposure of unhealed wounds may cause damage from drying, and invites infection by injurious fungi (320), severe pruning is commonly best performed toward the end of the dormant period, *i.e.*, in early spring, because healing is most rapid at the beginning of the growing

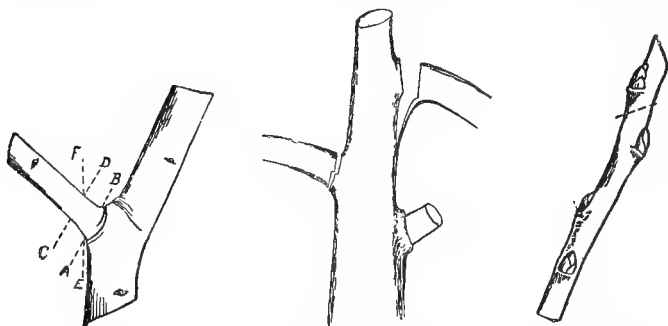

FIG. 156.

FIG. 157.

FIG. 158.

FIG. 156. — Pruning: showing the proper place to make the cut in pruning. A wound made by a cut on the dotted line *A-B* will be promptly healed. One made on the line *C-D* or *E-F* will not. In Fig. 157 the lower branch was cut off too far from the trunk.

FIG. 157. — Showing how to make the cut in pruning large branches. The upper cut, all made from above, permits the branch to split down. The lower cut, first made partly from below, prevents splitting down.

FIG. 158. — Pruning to an outside or inside bud. Cut as in the figure, the uppermost bud would form a shoot that tends to vertical. Cut on the dotted line, the uppermost bud would form a shoot tending to horizontal.

season (72). Pruning should not, however, be done at a time when sap flows freely from wounds, since this tends to waste reserve food. In plants subject to this, such as the maples and grape, pruning is probably best performed just before or just after the sap-flowing period.

418. Making the cut. — Since the movement of prepared food is mainly from the leaves toward the root

(80), it follows that when a branch is cut off at some distance from the member that supports it, the wound usually will not heal, unless there are leaves beyond the wound to manufacture food, and thus make a growth current possible (72). The cut should, therefore, be made close enough to the supporting member so that it can be healed from the cambium of the latter. In woody plants there is usually a more or less distinct swelling about the base of a branch (Fig. 156), produced by the cambium of the supporting member, and just beyond this swelling a more or less distinct line marks the point where the cambium of the branch and of the supporting members unite. In a healthy tree a wound made by a branch of reasonable size, cut off at this line, will usually heal promptly, but if the cut is made much farther out, it will not.

Wounds so large that they cannot heal promptly should be painted with lead and oil paint to preserve the wood.

419. Unhealed wounds introduce decay into the heartwood of trees, since the cells of the heartwood form a congenial field for certain destructive fungi (321), that having once gained entrance sooner or later destroy the heartwood of the whole trunk, thus greatly weakening it and preparing the way for the final destruction of the tree.

420. Objects of pruning. — If intelligently performed, pruning has one of four objects in view, viz. : (a) To change the form of the plant, as to outline or density (formative pruning). (b) To stimulate development in some special part, so as to promote the growth of wood or the formation of flower-buds (stimulative pruning). (c) To prevent some impending evil to the plant, *e.g.*, to arrest or exclude disease (protective pruning). (d) To hasten or retard maturity (maturative pruning).

421. Formative pruning aims to regulate the form of the plant with reference to outline or density, or to strength of stem. Pruning for outline includes pruning (*a*) for symmetry or picturesqueness; (*b*) for stockiness or slenderness.

422. Symmetry and picturesqueness. — Pruning for symmetry aims to develop in the plant a head that is

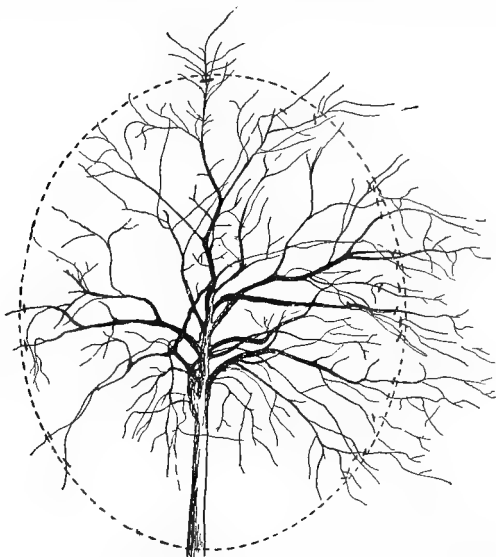

FIG. 159. — Pruning for symmetry. The branches growing beyond the ideal outline, indicated by the dotted line, should be cut off at the points indicated.

symmetric with reference to its trunk. The general principle involved is the suppression of growth in all parts that tend to grow beyond the lines of symmetry (Fig. 159). This is best accomplished by pinching (416) during the growth period, thus economizing the plant's

energy; but when the pinching has been neglected, the shoots that grow out of symmetry may be cut back during the dormant period.

In pruning for symmetry, the plant should generally be encouraged to develop the form that is natural to the particular species or variety, *e.g.*, the American elm tree (*Ulmus americana*) which naturally develops an open, somewhat spreading head, tending to be broadest toward the top, should not be pruned to the same form as the sugar maple (*Acer saccharum*) that develops a more roundish and compact head. Evergreens are sometimes pruned to ideal forms, as in topiary work, a practice that is generally condemned by good taste.

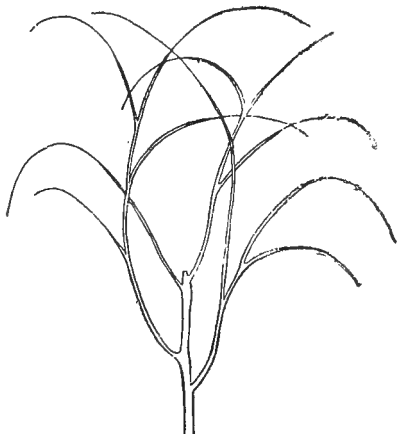

FIG. 160. — Raspberry cane rendered stocky by pruning.

Pruning for picturesqueness is seldom employed. It requires a thorough knowledge of pruning and of plant growth, combined with the conceptions of the artist.

423. Stockiness and slenderness. — Pruning for stockiness aims to develop a low head, with abundant branching, and a strong trunk. It is best accomplished by pinching (416) the uppermost growing points during the growth period, and encouraging low branching on the stem. If a spreading form is desired, the lower branches should be pruned to outside buds (Fig. 158).

Pruning for stockiness is much practiced in the raspberry (Figs. 160 and 161) and blackberry, in hedges and in many ornamental plants. In some plants it tends to the production of flower-buds, by checking growth of wood (136).

Pruning for slenderness is seldom necessary, since a slender growth may readily be produced by close planting. It is accomplished by persistently removing or cutting back the lower branches, and permitting only a few branches to develop near the terminus of the stem.

424. Pruning for density applies either to increasing or decreasing the density of the head. In ornamental and shade trees, a compact head is often desirable, while in fruit-trees, a head that admits abundant light and air (Fig. 165) is important (242). To increase density, encourage lateral branching by pinching all the more prominent terminal growing points (Fig. 163). In some coniferous trees, such as the Norway spruce (*Picea excelsa*), disbudding of the terminal shoots (Fig. 162) in spring is advisable, and in woody plants too tall for pinching, the more prominent terminal growing points may be cut back with the pole shears (431), which causes the head to grow more dense.

In pruning to form an open head (Fig. 165), it is wiser, as a rule, to thin out the smaller branches at some distance from the trunk than to remove large branches at their union with the trunk. The clearer the atmosphere

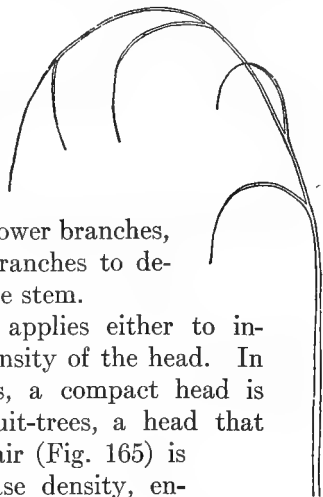

FIG. 161.—
Raspberry
cane not
pruned.

in a given locality, the less thinning of the top is required to produce the maximum number of fruit buds (243).

425. Pruning for strength. — Trees and plants grown in closely-planted nursery rows often have trunks insufficiently developed to support the head, when planted by themselves. To remedy this defect, we promote the



FIG. 162.

FIG. 163.

FIG. 162. — Disbudding: showing how to disbud shoots of some coniferous trees. Picking out the terminal bud *A* in spring usually causes both the adjacent lateral buds to develop.

FIG. 163. — Showing how density of growth is promoted (right-hand side) by persistent pinching of the terminal growing points.

formation of new vascular bundles (67, 123) by inducing branching, which we accomplish by cutting back the top in proportion to the slenderness of the trunk (423).

Trees expected to support heavy crops of fruit, or to endure high winds, should have branches developed with special reference to strength. In such cases several medium to small branches are better able to endure the strain than a few large ones (245), and the loss to the tree

of a small branch, should it occur, is less serious than that of a large one. In forming the head of fruit trees three or four foundation branches may be used, but these should by proper pruning be made to develop other smaller ones relatively close to the main trunk. Forks in the trunk of fruit trees, dividing the wood into two nearly



FIG. 164. — Unpruned apple tree, with head too dense to admit light.

equal parts are objectionable, since one or the other part is very likely to split down under the weight of a heavy fruit crop.

Main branches inclined to split down may sometimes be prevented from doing so by twisting two smaller branches together, to form a connection between them (Fig. 166). The branches thus twisted often grow together, forming a tie of great strength. A main branch

that has actually commenced to split down may often be saved by passing an iron bolt through it and the remainder of the trunk. A bolt thus inserted may become entirely inclosed by later growth.

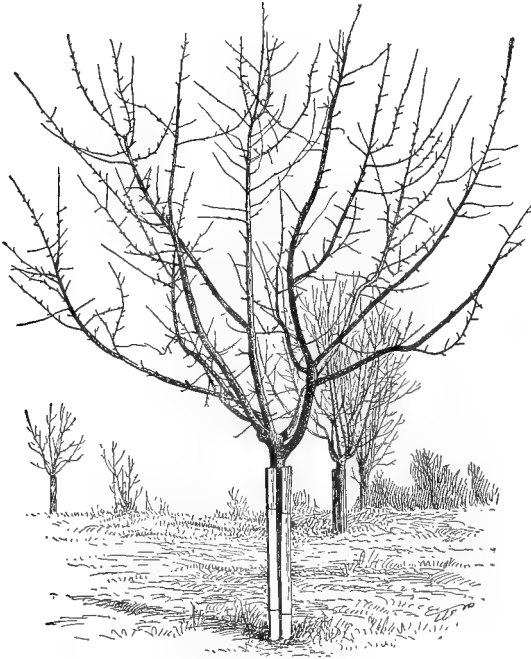

FIG. 165. — Apple tree pruned with open head, to admit abundant light.

426. Stimulative pruning depends upon the principle that the suppression of growth in one direction tends to stimulate it in others. Stimulative pruning may be employed either to stimulate growth of leaves, branches and roots, or of flower-buds.

427. Pruning for growth may be performed :

(a) *By removing a part of the branches*, thus reducing the number of growing points and the surface exposed to evaporation. Plants that are not making satisfactory growth, through feeble root action, may often be invigorated by this treatment, which is especially useful in trees recently transplanted or weakened by overbearing.

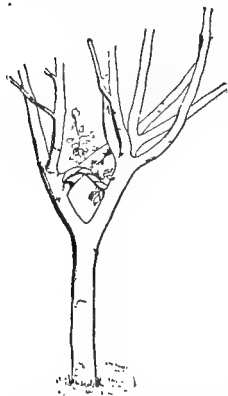

FIG. 166. — Branches of fruit tree tied together by a graft formed of twisted twigs.

(b) *By suppressing reproduction*.— When growth is desired, it is often advisable to prevent the development of flowers. Newly planted strawberry, raspberry and blackberry plants usually make better growth the first season if the flower-buds are picked off. The removal of flowers in the potato plant tends to stimulate the growth of tubers, especially in varieties that form seed. The removal of flower-buds from cuttings in the propagating bed encourages the formation of roots. Topping tobacco and rhubarb plants (416) causes the leaves to grow

larger, and in onion plants stimulates growth of the bulbs. De-tasseling corn encourages growth of the ears (416). Thinning fruit on plants that incline to overbear causes the remaining fruits to grow larger (159, 416).

428. Pruning for flowers or fruit.— Since checking growth tends to stimulate the formation of flower-buds (134), we encourage flowering in plants that incline to luxuriant growth, by pruning, which tends to check vigor. This may be accomplished :

(a) *By pinching the terminal buds* during the growth period, as is often practiced upon tardy-bearing fruit trees or upon seedling fruit trees of which it is desirable soon to learn the quality of the fruit. To be successful, it must be performed rather early in the growing season, and before the time for the formation of flower-buds. The blossoms do not usually appear until the season following the pinching.

With plants that flower at the terminal growing points of the principal branches, such as the spireas, hydrangeas, rhododendrons and the like, pinching to promote flowering is not advisable, since it tends to reduce the size of the flower clusters.

(b) *By cutting back the new growth.* — Woody plants that flower on stems more than one year old, such as the apple, pear, currant, etc., when grown on rich or well-cultivated ground, or that have been too severely pruned, often tend to produce an excess of new wood with a very feeble development of flower-buds. In such cases, it is advisable to equalize the growth by a moderate cutting back of all the young shoots. This must, however, be done with judgment. If the cutting back is too severe, it will stimulate more wood growth rather than the development of flower-buds.

(c) *By root pruning.* — This checks growth by reducing the number of root-tips, and thus cuts off a part of the water supply. It is applicable to the same cases as pinching, and is accomplished by cutting off the extremities of the roots by inserting the spade in a circle about the plant, or in the case of trees of considerable size, by digging a trench sufficiently deep to sever the lateral roots. The severity of the root pruning advisable will depend upon the vigor of the growth it is desired to check.

(d) *By obstructing the growth current.* — This is accomplished by ringing (416), by notching (416) and by peeling the stem (72).

When ringing is practiced, the width of the belt of bark removed should usually not be so great that the wound cannot heal over the same season by the callus formed on the upper edge of the ring (79), and it must be made sufficiently early to give time for healing. A wider ring will sometimes heal if the ringing tools are not inserted deeper than the cambium layer (80). In the grape vine, in which ringing is often practiced to increase the size and earliness of the fruit, the width of the belt removed is less important, since the canes that have borne fruit are generally removed in the annual pruning. But in fruit trees, the belt of bark removed should not much exceed one-eighth inch in width. Simply cutting through the bark with the pruning saw often accomplishes the desired end.

Notching above or below a bud or twig affects it much as ringing affects the entire ringed member. Notching below a bud or twig, therefore, checks its growth, and is often followed by fruiting in that part.

Peeling the stem has sometimes been practiced to make barren trees fruitful (72). It is a hazardous operation at best, and should only be used as a last resort. It is accomplished by making two cuts around the trunk, usually several inches apart, and just through the bark, with one or more vertical cuts between them, after which the bark between the circular cuts is carefully peeled off. It should only be performed during a period of very rapid growth, and at a time when the wood is well supplied with reserve food, *i.e.*, some time after the tree has put out leaves. It is most likely to succeed in

warm, dry weather, and when the wound is not shaded after peeling; otherwise, injurious fungi are apt to infect the ruptured cells.

429. Protective pruning. — Dead or dying members of a plant should be promptly removed, since they more or less endanger its well-being. Dead branches of any considerable size invite decay into the stem, which often results disastrously (419). Branches that are dying from infection by a parasite, such as the apple or pear blight, or the black knot of the plum (323), are especially dangerous and should always be removed as soon as discovered. Branches that tend to interfere with the growth of others already formed should be checked by pinching (416), and those that interfere by too close contact should be cut back in proportion to the interference.

Scraping off the dead bark scales from old fruit trees tends to remove certain destructive insects or their eggs. It should be done during the growing season. A short-handled hoe or a box-scraper is convenient for the work. Trees subject to sun-scald should generally not be scraped unless other trunk protection is given.

430. Maturative pruning. — Pruning to hasten maturity is seldom practiced. In nursery trees that tend to grow too late, and are thus subject to winter killing, the leaves are sometimes removed two or three weeks before the time when hard frosts are expected, to encourage ripening of the wood.

The later tobacco plants in a plantation are usually topped at the time the main crop is pushing the flower stalk, which causes their leaves to mature in season to be harvested with the rest of the crop.

For a discussion of pruning to retard maturity see paragraph 158.

431. Pruning implements. — The principal pruning implements are the following :

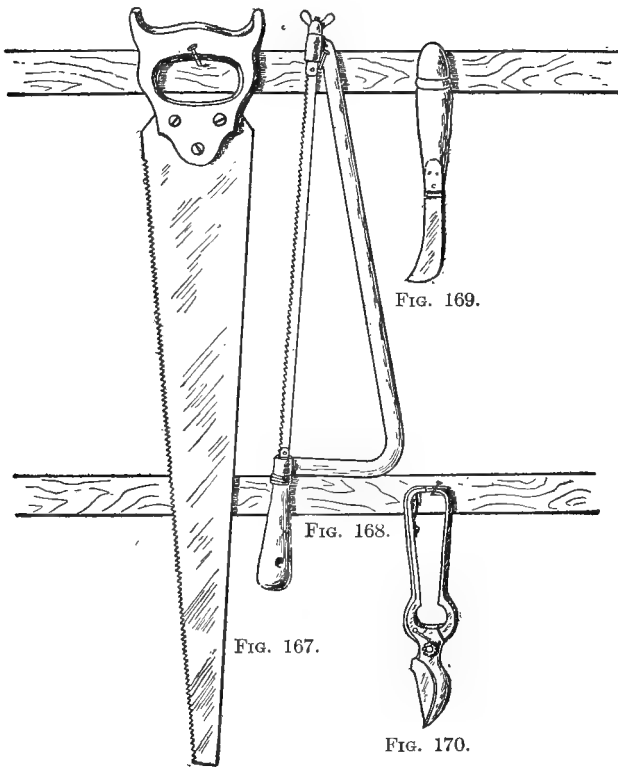

FIGS. 167-170. — Pruning tools.

FIG. 167. — "Sear's" pruning saw.

FIG. 168. — Perfection pruning saw.

FIG. 169. — Pruning knife.

FIG. 170. — All-steel pruning shears.

The *pruning knife* (Fig. 169) is useful for removing small woody shoots. The blade should be of good steel,

and the point should curve forward a little, to prevent the edge from slipping off the branch. The handle should be large to avoid blistering the hand, the base of the blade should be thick to furnish support for the thumb, and the rivet should be strong enough to sustain hard pressure upon the handle.

In using the pruning knife, the shoot to be cut off should generally be pressed with one hand

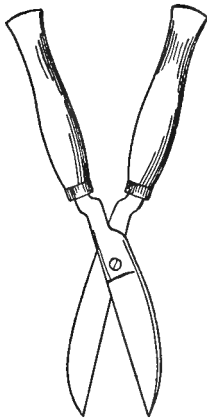

FIG. 171.

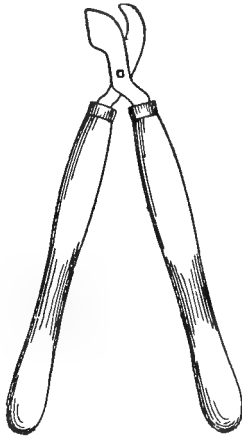

FIG. 172.



FIG. 173. FIG. 174.



FIG. 171. — Hedge shears (much reduced).

FIG. 172. — Lever shears (much reduced).

FIG. 173. — Pole shears. The wire connects with a lever not shown in the figure.

FIG. 174. — Raspberry hook.

toward the member that supports it and the blade should be inserted at the proximal side. Care is necessary to prevent the blade from cutting too far.

The *pruning saw* (Figs. 167–168) is useful for cutting off large limbs. There are many kinds of pruning saws.

The two illustrated in Figs. 168 and 169 are in common use and are of the better types.

The pruning shears (Fig. 170) may be used for the same purpose as the pruning knife, but they cut less smoothly, and less close to the supporting member. They should be used with the beveled edge of the blade in close contact with the supporting member. They are excellent for cutting cions (386), and making cuttings (358). The form shown in the figure is one of the best.

The hedge shears (Fig. 171) are especially useful for pruning hedges.

The lever shears (Fig. 172) are useful for cutting off sprouts about the base of trees.

The pole shears (Fig. 173) are useful for cutting back the shoots of tall trees, and for removing sap sprouts (223), though for this purpose they have the fault of the pruning shears in not cutting sufficiently close to the branch. They should not be used for shoots much exceeding one-half inch in diameter.

The raspberry hook (Fig. 174) is used for cutting off the dead fruiting canes of the raspberry and blackberry. The cutting part is made of a rod of good steel, five-sixteenths inch in diameter, flattened and curved as shown, with a moderately thin edge on the concave side of the curve. The handle should be about three feet long.

The following books are recommended for reading in connection with the preceding chapter: *The Nursery-Book*, Bailey; *Greenhouse Construction*, Taft; *Barry's Fruit Garden*, Barry; *The Art of Grafting*, Baltet; *The Pruning-Book*, Bailey; *How to Make the Garden Pay*, Greiner.

CHAPTER XVIII

PLANT-BREEDING

WE should find little satisfaction in the culture of plants if we could not improve them. The improvement may be in larger size of the entire plant or any of its parts, change in color, shape, flavor or other characteristics. The whole subject of improving or modifying plants by plan and forethought is known as plant-breeding.

432. Improvement of plants under culture. — From our point of view, our cultivated varieties of plants are superior to their wild prototypes. The strawberries of our gardens are larger, more productive and firmer than those of the fields; the cultivated lettuces are more vigorous, more tender and milder in flavor than wild lettuces; and the cultivated cabbages and cauliflower are greatly superior, in the food products they furnish, to their progenitors. The superior qualities of long-cultivated plants, as compared with their wild parents, are conspicuous wherever the wild forms are known.

433. Causes of improvement. — This improvement probably results from two causes. In culture, the natural hindrances to development are largely removed. Cultivated plants are less crowded by too-near neighbors than wild plants, and they commonly receive more abundant

food and moisture. They are, therefore, able to reach higher stages of development than is possible in nature, where plants are constantly restricted by environment.

The principle of selection has doubtless been more or less operative since the beginning of culture (19). All of our cultivated plants must have existed originally in the wild state. The most satisfactory plants of any desirable species have been most carefully guarded, and when the art of propagation became known, these plants were most multiplied. In each successive generation, the most desirable individual plants of each species were protected and multiplied, or at least were permitted to perpetuate themselves. Since the offspring tends to resemble the parent (18), the persistent propagation from the best has resulted in more or less marked improvement. Chance crossings have aided the process (445). These facts furnish hints for the further improvement of plants.

434. Variability. — The variability of plants renders their improvement possible. In a species of which the individual plants are all practically alike, as in many wild plants, we can do little in the way of plant-breeding, except to give treatment that promotes variability. In a species in which the individuals manifest different qualities, however, we may hope to secure improvement by using the more desirable plants as parents from which to secure still further variability.

435. Reversion. — Variations are not always permanent. If we find a chance seedling of the wild blackberry, for example, that has remarkably fine fruit, the plants grown from seeds of this fruit are not always equal in quality to the parent. The tendency, in such cases, is for the seedling plants to revert or go back to the ordinary type

of the species, and the more marked the variation, the stronger is the tendency to reversion.

436. How to fix desirable variations. — A fixed variation, *i.e.*, a variation of which the progeny resembles the parent in all important characters, becomes a variety (21) as this word is used with reference to cultivated plants. Varieties that produce their more important characters when grown from seed are often called races. There are two possible ways of fixing a desirable variation :

(a) *By propagating the plant by division* (345). — This enables us to maintain a given variation through many generations with comparatively little deviation from the form with which we started (341). Our varieties of fruits, potatoes, geraniums and many flowering plants, and of many of our finest ornamental trees and shrubs are fixed in this manner. It is well known that varieties propagated in this way rarely “come true” from seed, *i.e.*, their seed does not usually produce plants of the same variety as the parent. But it is not practicable to propagate all plants by division. With plants more conveniently propagated from seed, such as the cereals, Indian corn and most garden vegetables, we may fix varieties to a certain limit.

(b) *By persistent selection toward an ideal type.* — For example, if we discover a single pea plant in a row of peas that produces earlier pods than any other plant and we desire to fix this variation, we should save all the peas from this plant and sow them the next spring. Most of the plants from this seed will probably be later than the parent, but two or three of them may equal it in earliness. We should save the seeds from the earliest plant again, and continue this selection through several seasons. It would be well to note the incidental char-

acters of the earliest plants, *i.e.*, whether the pods are borne singly or in pairs, if they are straight or crooked, and whether the plants are tall or dwarf. Having decided on the characters that seem to accompany the extreme earliness, we should save seeds only from plants that show all of these characters. After following this kind of selection eight or ten years, we may be able to introduce a new variety of pea.

It is impossible so to fix variations in plants grown from seed that they will continue to come true without a certain amount of selection, hence varieties propagated by seed continually tend to "run out," *i.e.*, to lose their distinctive characters. Seed growers find it necessary to use the utmost care in maintaining their varieties, and the more distinct a variety propagated by seed, the more difficult it is to maintain.

437. Seed selection is of great importance. From what has been said, it is clear that the cultivator cannot afford to be indifferent as to the quality of the seed he sows. It is not enough that the seed is fresh and plump; it should be of carefully-bred varieties. In the cabbage and cauliflower, success or failure in the crop will depend largely upon the quality of seed sown, and the same is more or less true in all crops grown from seed.

438. Inducing variation. — We can induce variation, in some cases, by special treatment of the parent plants, or by the use of a particular selection of seed.

By culture. — It is generally conceded that culture tends to promote variations that would not have appeared in the wild state, in consequence of the changed growth conditions. In improving wild plants, therefore, we probably have a better chance of securing vari-

ation by gathering seeds from such wild plants that have been placed under high cultivation than from those that have not been submitted to culture.

By growing seedlings.—In plants habitually propagated by division (345), such as the apple, potato, dahlia and the like, we secure variation by growing plants from seed. The parent plant, not having been fixed by long selection, as is the case with varieties grown from seed, is in a state of variation, and hence its progeny usually vary widely. From these variable seedlings, desirable individuals may be selected for fixing. Since most of our varieties that are propagated by division are highly developed, their seedlings are usually, though not necessarily, inferior to the parents.

By crossing varieties or species.—This is the most important method of plant improvement. By procuring fecundation of the germ cell of a plant of one variety with pollen from a plant of a different variety or species (149) through cross-pollination (151), we obtain a variable progeny of which the individual plants may be expected to resemble both parents in different degrees. For example, if we secure fecundation of a number of ovules of the Worden grape with pollen from the Delaware grape, and plant the seeds from the fruits thus secured, we may expect that some of the seedlings will resemble both parents about equally, that others will chiefly resemble the Worden, but will show a few characteristics of the Delaware, while others again will chiefly resemble the Delaware, but will possess a few characteristics of the Worden. It would not be surprising if we secure a vine having the vigor, productiveness and large fruit of the Worden, with the color and delicious flavor of the Delaware. This we may almost certainly

accomplish if we continue our trials a sufficient time. In other words, we may often combine the good qualities of two varieties into a single variety by securing a number of cross-fecundations between the two (440), and rearing plants from the seeds thus formed.

439. Selection of subjects for crossing.—If the object of crossing is simply to secure variation, as is sometimes the case with wild fruits, the parents should differ from each other as widely as possible, provided only that they are capable of crossing freely. Crosses between allied species, when this is possible, will be more likely to accomplish the object sought than between plants of the same species.

If the object is the improvement of present varieties, the parents should be chosen with reference to the qualities desired in the new variety. For example, if it is desired to produce a hardy, late-keeping apple, of first quality, any hardy variety that keeps well, whatever its quality, may be crossed with any other hardy apple of first quality, whether it keeps poorly or well, though of two apples of first quality, the better keeper should be chosen.

The plant-breeder should first have a definite idea of the qualities he desires to secure in his proposed variety, and should then study with much care the qualities of the varieties that he proposes to use as parents. The two varieties that contain the largest number of the desired qualities should be chosen.

440. Cross-fecundation is accomplished through cross-pollination of the flowers (151); *i.e.*, by placing pollen from the anthers of a flower of one of the varieties we desire to cross upon the stigma of the other variety.

441. Preparing the flower for crossing.—To prevent self-pollination (151) in perfect flowering plants

(153), we emasculate the flowers, *i.e.*, remove the anthers (143) before the pollen is mature. Prior to maturity, the anthers are generally pale in color and nearly smooth on the surface, with no visible pollen, but a little later, the pollen in most plants is visible as a bright yellow dust adhering to the anthers. The anthers may be picked off with the forceps, or the filaments that support them may be clipped off with the points of the scissors. They must generally be removed

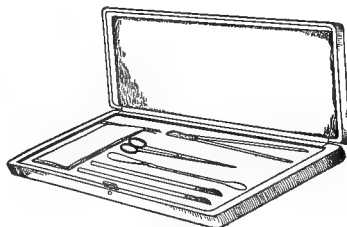

FIG. 175. — Case of instruments and sacks for crossing plants.

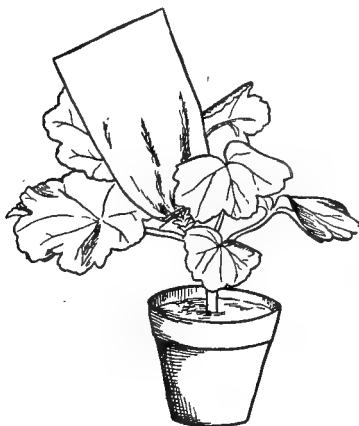

FIG. 176. — Emasculated flower inclosed in sack.

before the petals open (142). The latter may be gently opened with the forceps or needle, or they may be carefully removed. A set of useful implements for this work is shown in Fig. 175.

In the flowers of certain plants, such as the pea, wheat and grape, pollination takes place before the blossom opens, hence in these plants it is necessary to emasculate the flowers very early.

442. To prevent undesired pollination, the blossom should be inclosed by tying over it a sack of thin cloth or paper at the time of removing the anthers. The sack

will of course have to be removed for pollination, after which it should be promptly replaced (Fig. 176).

Pollination should be performed twenty-four to forty-eight hours after emasculation (441), the period depending upon the plant and the stage of development of the flower at the time of the latter operation (150). Applying the pollen on two consecutive days tends to insure success.

The pollen is applied by placing an anther (143) containing mature pollen in direct contact with the stigma (144), or by removing some of the pollen upon the back of the point of a penknife or by means of a camel's-hair brush, and carefully applying it to the stigma. A pin, of which the head has been flattened by hammering, inserted in the end of a stick, forms a convenient tool for this work. A slender stick of sealing wax drawn to a blunt point may be used in pollination by rubbing it on the sleeve to electrify it.

The best time for pollination in the open air is often in the early morning, since the atmosphere is then usually still, and contains little pollen from other flowers, which, if freely present in the air, may vitiate the results of pollination.

443. The after-care of crosses. — After the last pollination, the blossom should again be inclosed until fecundation is effected, which is indicated by a rapid enlargement of the ovary. The paper sack may then be replaced by one of mosquito netting. This should be securely, but not too tightly, tied about the stem of the pollinated flower, to protect the inclosed fruit or seed-vessel from injury during growth and maturity, as well as to render it conspicuous. A label should be placed within the sack, or tied on with it, giving the name of the variety whence the pollen was secured. It is also

desirable to record all the operations and observations relative to the crossing.

444. The selection of crossed seedlings is a most important operation in producing new varieties by crossing. If none of the seedlings of the first generation exhibits the desired qualities, those of a succeeding generation may exhibit them. The plants nearest the ideal should be selected, and all the seeds from these preserved for planting. When the ideal plant is found, it may be readily fixed by means of cuttings or grafts in plants generally propagated in this way. In those propagated by seed, several generations of culture and selection may be necessary before the progeny will uniformly resemble the parent.

445. Planting with reference to chance crossings. — Many valuable varieties have unquestionably arisen from accidental crosses between plants of different varieties that chanced to be growing in proximity. Profiting by this hint, varieties are sometimes planted near together to favor self-crossing, a practice to be encouraged.

446. Plant-breeders are benefactors. — He who produces fruits or flowers for others works a transient good. But he who produces a variety of fruit or flower that is superior to any now known confers upon his race a permanent good. Until the introduction of the Wilson strawberry, the markets of our country were not supplied with this delicious and wholesome fruit, because no known variety was sufficiently productive to be generally profitable, or sufficiently firm to endure long carriage. There are wild fruits in our copses to-day that are doubtless worthy of improvement, and in most of our fruits now under culture the development of superior varieties would greatly enhance their value. "The harvest is truly great, but the laborers are few."

The following books are recommended for reading in connection with the preceding chapter: Plant-Breeding, Bailey and Gilbert; Variations of Animals and Plants under Domestication, Darwin; Propagation and Improvement of Cultivated Plants, Burbridge; Origin of Cultivated Plants, De Candolle; Punnett's Mendelism; Principles of Breeding, Davenport.

APPENDIX

A SYLLABUS OF LABORATORY WORK

THE laboratory exercises here outlined have been used by the author in his instructional work.

Each student performs the exercises, so far as possible, and the apparatus needed is provided. The student should be required to write a description of the work performed, stating results in every case, supplementing his notes by drawings in special cases.

It has not been found practicable to make the lecture room and laboratory work fully correspond as to time, but the effort has been made to do this as far as possible.

A greenhouse is very desirable for this kind of instruction, and if the instruction is given in winter, a "garden house," *i.e.*, a glass house inclosing an unobstructed area of garden soil is scarcely less important. But in the absence of these conveniences, a few window boxes will furnish a tolerable substitute.

When the exercises are carried out during winter, considerable foresight is essential to have the needed materials in condition for use at the proper time.

To stimulate observation (1).¹ — A few object lessons are given to encourage observation and correct reason-

¹The numbers in parentheses refer to the paragraphs in the book.

ing. A twig, an ear of corn or a potato tuber is given to each student and all are encouraged to vie with each other in discovering new points, and in discussing the reasons therefor. This lesson is frequently repeated during the term.

Cell structure (12). — The students examine the pulp of a mealy apple and of a potato, and cross-sections of a young bean plant, with simple lenses of rather high magnifying power. If a compound microscope is available, many mounted objects illustrating the cell structure of plants may also be shown.

Absorption of water by seeds (26). — For the exercises suggested by paragraphs 26 and 27, a means of weighing and of measuring the volume of large seeds, as beans, with some degree of accuracy is needed. The device shown in Fig. 177 answers this purpose, and one can be provided for each pair of students at a moderate cost. It consists of a graduated glass cylinder of 200 cubic centimeters capacity and a test tube about 6 inches long.

For determining the volume, the cylinder is partly filled with water and the height to which the water rises is noted. The seeds are then dropped in and the glass is shaken a little to remove the air bubbles. The height of the water is again noted, when the difference in the two readings indicates the volume of the seeds in cubic centimeters. For weighing the empty test tube is placed in the cylinder

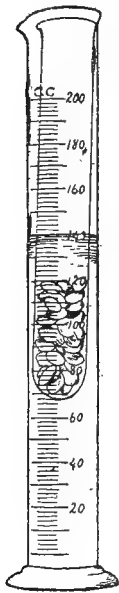

FIG. 177. — Device for weighing and determining the volume of seeds.

in the position shown (Fig. 174). The height to which the water rises is then noted, after which the seeds are dropped into the test tube, and the top of the cylinder is jarred slightly by tapping it with a pencil. The height of the water is again noted, when the difference in the readings indicates the weight of the seeds in grams.

The test tube should float in the center of the cylinder, as shown, and the readings should be taken with the eye on a level with the surface of the water.

Each student (or pair of students) is provided with the apparatus shown in Fig. 174, and with two bottles of at least 100 cc. capacity, with corks. Each bottle should have a strip of white paper pasted vertically upon it to receive the name of the student and other data.

Each student weighs or measures the volume of 50 fresh seeds of the bean, pea or Indian corn in the manner described above. Having noted the weight or volume in his notebook, he pours the seeds, with the water, into one of his bottles, corks the latter and writes his name, with the date, on the paper pasted on its side. He then repeats the process with seeds of the honey locust, yellow wood or some other seed that does not readily absorb cool water, and after recording the data in his notebook, places the bottles in a warm place until the following day, when he again determines the weight or volume of the two kinds of seeds. The seeds placed in the first bottle will usually be found to have nearly or quite doubled in size, while those in the second bottle have scarcely swollen at all.

Next, show the class a sample of the second lot of seeds that have fully swollen from soaking in hot water. Impress upon their minds the fact that while most seeds

readily absorb moisture at ordinary temperatures, a few kinds do not, and seeds of the latter class need to be soaked cautiously, before planting, in hot water (27).

The rate at which seeds absorb water depends

(a) Upon the water content of the medium (27). Weigh 3 samples of navy beans. Place one sample in water, a second in very damp earth and the third in slightly damp earth. Weigh again the next day and compute the water absorbed by the three lots.

(b) Upon the point of contact. Weigh 2 samples of navy beans, placing one sample in moist soil without compacting, and the second in the same kind of soil well compacted about the seeds. Determine the water absorbed by the two samples the next day.

(c) Upon temperature. Repeat the above with 2 samples of navy beans, placing one lot in a temperature of 80° to 90° F., and the other in 40° to 50° F.

Other means of using the apparatus shown in Fig. 174 will occur to the thoughtful teacher. It may be used for determining specific gravities by dividing the weight by the volume.

Germination (28). — Give an exercise in testing seeds with the apparatus shown in Fig. 6.

Moisture essential to germination (29). — Soak one lot of navy beans in water until they are fully swollen and another lot until they are about half swollen. Wipe the beans as dry as possible, put each lot into a bottle, cork the bottles, and set them in a warm room. The fully-swollen beans will usually germinate promptly, while the others will not.

Oxygen essential to germination (31). — Perform the saucer experiment as described.

Also place seeds of rice in two bottles, and add to

each water that has been boiled 20 minutes; cover the water in one bottle with a little olive or cotton-seed oil. It is important to soak the seeds a short time in boiled water before putting them into the bottles to remove the air in contact with their seed-cases.

Germination hastened by soaking seeds (35). — Soak seeds of Indian corn two or three hours in warm water, and let each student place in a seed-tester a sample of the soaked seeds, with one or two other seeds of the same kind that have not been soaked.

Germination hastened by mutilating the seed-case (36). — This may be illustrated with seeds of the navy bean, in the seed-tester.

The plantlet (40). — Place seeds of radish, onions, etc., loosely on the surface of a saucer filled with fine moist loam; keep the surface moist and note the repeated attempts of the hypocotyl to enter the soil.

Seeds of the pumpkin family should be planted flatwise (42). — Plant seeds of the pumpkin or squash, in the three positions indicated, in large greenhouse saucers. Cover each saucer with a pane of glass and place all in a warm room until the plantlets appear, after which note the number of each lot of seeds of which the seed-case appears above the surface.

Development of plantlets (44-46). — Devote several exercises to a study of the development of plantlets of the bean, pea, wheat, Indian corn, pumpkin, etc. To furnish the plantlets, seeds of the different sorts should be planted on several successive days, beginning at least 10 days in advance.

Not all seeds should be deeply planted (47). — Plant seeds of the bean, pea, Indian corn and wheat in 6-inch flower pots, at three different depths, viz., $\frac{1}{2}$ inch, 3

inches and 6 inches from the bottom; place the pots in a warm place for 3 weeks, after which carefully remove the soil, noting the germination of the seeds in the different layers.

Vigor of plantlet proportionate to size of seed (48). — Plant large and small specimens of navy beans by themselves, in greenhouse saucers, and permit them to germinate. The smaller seeds usually germinate earlier than the larger, but they produce more slender plantlets, which soon fall behind the others in development.

Plantlet visible in the seed (53). — Boil samples of various kinds of seeds until they are fully swollen, after which require the students to dissect them and to seek out the plantlets. Lenses, needles and forceps are very useful in this work.

The cotyledons a storehouse for food (59). — Remove the cotyledons of some bean plantlets growing in a flower pot or saucer, leaving those of other plantlets intact. After a week note the result in the checked growth of the mutilated plants.

Vascular bundles (67). — Study these as shown in the stalk of Indian corn, in the leaf stems of various plants and in the leaf scars on the stems of plants.

Cambium layers (68). — Locate these in sections of various dicotyledonous stems, including the potato tuber; also note the absence of the cambium layer in monocotyledonous stems.

Root-hairs (100). — Study these as illustrated when seeds germinate in the seed tester. Germinated radish-seeds, left in the seed-tester two or three days, usually develop root-hairs in great abundance. Also search out the root-hairs in potted plants. Emphasize the difference between root-hairs and root branches.

Effects of transplanting on root branching (104).— Study young plants of lettuce, tomato, cabbage, etc., that have been pricked off, and compare their roots with those of others that have not been pricked off.

Relation of roots to food supply (111).— Plant seeds of the radish in saucers containing clean sand and potting soil respectively, and when the seedlings have attained some size, wash out and examine the roots in the two soils.

Root tubercles (112).— Study the roots of young clover plants of various ages, and note how early in the development of the plant the tubercles are discernible.

Underground stems (114).— Study the development of the potato plant from growing specimens, noting the points at which the tuber-bearing stems originate, and the marked difference between these and the roots.

Nodes and internodes (115).— Observe the nodes in the stems of many plants, noting the relation of the diameter of the young stem to the length of the internodes; also note the undeveloped internodes near the terminus of the stem.

Buds (127).— Study specimens of leaf-buds from many plants, noting their structure, position, etc.

Flower-buds (132).— Study the form and location of the flower-buds in many plants, particularly in fruit trees.

Parts of the flower (140).— Study the parts of the flower, explaining the function of each part.

Perfect and imperfect flowers (153).— Study these as produced by several different plants, particularly of the strawberry.

Degree of maturity necessary to germination (162).— Test seeds of Indian corn, pea, tomato, etc., that were gathered at varying stages of maturity.

Seed vitality limited by age (164). — Test seeds of lettuce, parsnip, onion, etc., 1 year, 2 years and 5 years old, respectively.

Stratification of seeds (169). — Perform the process, as described, in boxes or large flower pots.

Sun-scald (185). — Require each student to make a lath tree protector (Fig. 59).

Winter protection of plants (201). — Protect half-hardy shrubs by wrapping them with straw or covering them with earth.

Foretelling frost (206). — Devote an exercise to the use of the psychrometer and the computation of the dew point.

Plant protectors (278). — Require each student to make at least one plant protector, as shown in Fig. 67, patterns for which are to be furnished.

Kerosene emulsion (294). — Let each student make a given quantity of the kerosene emulsion after one of the formulæ given.

Spraying pumps (304). — Give at least one exercise to the construction and use of spraying pumps and nozzles.

Prevention of grain smuts (325). — Require the students to treat a quantity of oats with formalin as described.

Bordeaux mixture (329). — Require each student to make a stated quantity of the bordeaux mixture after the formulæ given. The better mechanical quality of the freshly prepared mixture can be determined as follows. Prepare a sample of the mixture and allow it to stand some time, *e.g.*, a day or a week, and settle. Prepare a fresh sample, then shake both up and allow them to stand side by side in tall glass jars or bottles and compare the rate of settling. A similar comparison may be made as to

rate of settling of mixtures prepared by the use of dilute solutions (as recommended) alongside of mixtures made from concentrated solutions.

Propagation by seeds (344). — Instruct the students in the use of the hand seed-drill and broadcast sower. Let them ascertain how much clover seed the broadcast machine is sowing to an acre, by laying on the ground or floor several sheets of paper, exactly one foot square, painted with glycerine to catch the falling seeds. Having learned the average number of seeds deposited per square foot with a given rate of motion of the machine, let the students compute the number of seeds sown per acre, and reduce this to ounces. The number of clover seeds in an ounce may be ascertained by dividing an ounce of seed among the students for counting.

Propagation by layers (349). — Instruct the students in layering canes of the grape, and in mound-layering the stems of the gooseberry.

The bulb (352). — Dissect bulbs of the onion, tulip, lily, and the like, ascertaining their structure and finding the embryo flowers.

The coldframe (364). — Require the students to make a drawing and write a description of a coldframe, from a model furnished them.

The hotbed (365). — Let the students assist in making a hotbed after the plan described. Also let them note the temperature of the soil within the frame on several successive days after the bed is finished, and give them instruction in ventilating the hotbed.

The propagating bed (368). — Require the students to make a propagating bed in the greenhouse, after the plan described.

Stem cuttings (373-375). — Let the students make

cuttings from the stems of the grape, currant, etc., and plant them, both in the propagating bed and in the garden.

Root-cuttings (376). — Give a lesson in making root-cuttings of the raspberry or blackberry, in packing the same for winter storage and in planting them in the propagating bed and in the garden.

Green cuttings (380–381). — Give a lesson in making and planting cuttings of coleus, geranium, rose, etc., followed by instructions in the care of green cuttings in the propagating bed.

Leaf cuttings (382). — Give a lesson in making and planting leaf cuttings of the begonia.

Grafting-wax, etc. (387–389). Give a lesson in making grafting wax, grafting cord and grafting paper, as described.

Tongue-grafting (390–391). — Give several lessons in whip-grafting, including grafting both of the stem and of the root.

Cleft-grafting (392). — Give one or two lessons in cleft grafting.

Side-grafting (393). — Give a lesson in side grafting, as described.

Budding (394). — Give one or more lessons in budding, as described. The bark on the stocks may be made to peel by boiling, and trimmed bud sticks may be preserved for winter use, in dilute alcohol.

Approach-grafting (399). — Give one exercise in approach grafting, as described.

Packing plants for transportation (405). — Devote one exercise to packing strawberry, cabbage or some other herbaceous plants, as described.

Heeling-in, replanting (408–410). — Give one or more

lessons in heeling-in and planting trees, as described; also at least one lesson in planting root grafts, cuttings and herbaceous plants as shown in Figs. 143-144; and a lesson in planting strawberry plants.

Potting and shifting (412). — Give two or more lessons in potting and shifting as shown in Figs. 145-148.

Pruning (427 etc.). — Give one or more lessons in pruning by the methods described.

Cross-pollination (441). — Give one or more lessons in cross-pollination, as described.

INDEX

Note. — Laboratory exercises indicated thus: (lab.).

- Abortion, in flower, 90.
Absorption of water,
 by root-hairs, 65.
 by seeds, 14, 15, 296.
Adventitious buds, 80.
Aëration of soil, 63, 147.
Agitator, 167.
Albumen, 32.
Ammoniacal copper carbonate, 181.
Animal parasites, 152.
Anther, 88.
Anticyclones, 125.
Approach-grafting, 230, (lab.),
 284.
Army-worm, 163.
Arsenic compounds, 156.
Arsenites, 156, 157.
 mixing with bordeaux, 181.
Art, definition of, 1.
Ashes, wood, 150.
Assimilation, 35.
Atomizer, 164.
Axillary bud, 78.
- Bacteria, 174.
Bark,
 bursting of, 117.
 living part of, 48.
 removal of, 49.
Birds, 154.
Black-heart, 115.
Blanching, 141.
Bordeaux mixture, 180, (lab.),
 282.
Borers, 169.
Bottom heat, 197.
Branches, development, 79.
 removal, 250.
- Breeding, 9.
Broom rape, 173.
Budding, 224, (lab.), 284.
 conditions for success, 226.
 knife, 229.
 removal of buds for, 227.
 time for, 225.
Buds, 78, (lab.), 281.
 protection of, 79.
Bud-sticks, 226.
Bulbels, 194.
Bulbs, 194, (lab.), 283.
- Callus, 48, 49.
 experiment in forming, 55.
 on dormant cuttings, 204.
Calyx, 87.
Cambium, 45, (lab.), 280.
 uniting of, 46.
Cauliflower, 139.
Cell, structure, 6, 276.
 elongation of, 139.
Chinch-bug, 162.
Chlorophyll, 34.
Cion-grafting, 216.
 time for, 217.
Cions, 214.
 length of, 221.
 cutting and storage of, 216, 217.
Classification of plants and animals,
 9, 11.
Cleft-grafting, 221, (lab.), 284.
Climate, effect on cuttings, 197.
Codlin moth, 170.
Cold, effect of, 113.
 injury, 119.
 protection against, 119.
Cold-air drainage, 125.

- Coldframe, 199, (lab.), 283.
 Cold pit, 200.
 Composite flowers, 91.
 Copper sulfate, 181.
 Corn, 195.
 Corolla, 88.
 Cotyledons, 28.
 Cracking, of fruits and vegetables, 132.
 of seed case, 22.
 Crop rotation, 151.
 Crossed seedlings, selection of, 273.
 Crosses, 12, 269.
 after-care of, 272.
 Crossing, chance, 273.
 preparations for, 270.
 Cross-fecundation, 270.
 Cross-pollination, 93, (lab.), 285.
 advantages of, 94.
 Crown, division of, 192.
 Cultivation, of soil, 135.
 to induce variations, 268.
 Culture, 4.
 of plants, 2.
 Curculio, 171.
 Cuticle, 41.
 Cuttings, 107, 196.
 autumn planting of, 206, 207.
 characteristics of, 197.
 conditions favoring growth of, 197.
 dormant, 204.
 green, 209, 211.
 influence of air temperature on, 198.
 mallet, 207.
 of evergreen plants, 205.
 of leaf, 212.
 of root, 208.
 of stem, 206.
 parts used for, 197.
 "saucer system" for, 211.
 storage of, 205.
 with heel, 206.
 Damping-off, affecting green cuttings, 211.
 De-flowering, 249.
 De-fruiting, 249.
 De-tasseling, 249.
 Density, pruning for, 254.
 Depth, of planting seeds, 30, 187.
 of roots, 69.
 Development, abnormal, 139.
 of fruit, 96.
 of leaves, 76.
 Dew-point, computing of, 123.
 Diameter of stems, increase of, 47.
 Dibber, 241.
 Di-cotyledons, 28.
 Diffusion, 39, 40.
 Diœcious flowers, 94.
 Disbudding, 249.
 Disease, 6.
 control, 175.
 in cuttings, 211.
 resistance, 182.
 Diseases, non-parasitic, 182.
 preventable by spraying, 179.
 Distance of planting, 76.
 Distribution of food materials, 39.
 Division, propagation by, 188.
 Didders, 174.
 Domestic plants and animals, 3.
 Dormant buds, 80.
 Dormant plants, propagation by cuttings, 204.
 Dormant protoplasm, 7.
 Drainage, for potted plants, 63.
 in pots, 243.
 Dressing, of nursery stock, 248.
 Dropsical condition, 131.
 Dry soil, 119.
 Drying, effect on seeds, 102.
 of plant tissue, 136.
 Duster, 164.
 Dwarfing, of plants, 145.
 by grafting, 215.
 Elaborated sap, flow of, 54.
 Electric light, 141.
 Elements, 37.
 Emasculation of flowers, 271.
 Embryo, 32, 186.
 Endosperm, 32.
 Environment, definition of, 2.
 factors of, 109.
 Epidermis, 41.

- Evergreens, affected by heat, 110.
 cuttings of, 205.
- Evolution, theory of, 12.
- Exposure, 120.
- Extension rod, 165, 166.
- Families of plants and animals, 10.
- Fecundation, 92.
- Feebleness, 4.
- Fermenting material for hotbeds, 200.
- Fertilizers, nitrogenous, 150.
- Fir tree oil, 162.
- Floret, 91.
- Flower-buds, 81, (lab.), 281.
 conditions affecting formation of, 83, 84, 86.
 killing of, 117.
- Flowers, abortive parts of, 90.
 composite, 91.
 effect of on plant, 87.
 imperfect, 95, (lab.), 281.
 killing by frost, 118.
 monœcious and dicecious, 94.
 of grasses, 91.
 parts of, 87, (lab.), 281.
 perfect 94, (lab.), 281.
 preparation for crossing, 270.
 pruning for, 258.
 use of, 87.
 variation in form, 90.
- Foliage, 85.
- Food, effect of lack of, 145.
 excessive, 144.
 formation of, 34.
 gathering by root-hairs, 65.
 in cotyledons (lab.), 280.
 prepared, 54.
 reserve, 7, 56, 84.
 restriction of current of, 56.
 source of for animals, 36.
- Food elements, deficiency of, 146.
- Food materials, distribution of, 39.
- Formaldehyde treatment of seeds, 177.
- Formation, of flower-buds, 83.
 of head in fruit-trees, 256.
- Formative pruning, 251, 252.
- Forms of trees, 253.
- Freezing, 113, 114.
- Freezing point, 120.
- Frenching of tobacco, 131.
- Frost, action in soil, 61.
 factors tending to avert, 126.
 fortelling of, 122, (lab.), 283.
 liability to, 127.
 methods of preventing injury by, 127.
 relation to wind, 142.
- Frost-cracks, 116.
- Frost-ribs, 116.
- Frozen tissues, treatment of, 115.
- Fruit, development of, 96.
 pruning for, 258.
 ripening of, 98.
 thinning, 97, 249.
- Fruitfulness, 56.
- Fruit spurs, 82.
- Fruit-trees, 256.
- Functions, of elements, 37.
 of leaves, 75,
 of root, 58.
- Fungi, 174.
- Fungicides, 179.
- Fungous attacks, 142.
- Genus, 10.
- Germination, failure, 22.
 hastening, 21, (lab.), 279.
 importance of prompt, 20, (lab.), 268.
 relation to moisture, 16; to oxygen, 19; to warmth, 17, 21.
 time of, 98.
 time required for, 24.
- Girdled trees, 215.
- Girdling, 55.
- Gophers, 153.
- Gormands, 132.
- Grafting, 214.
 limits of, 215, 216.
 methods of, 216, 220-224.
 objects of, 215, 257.
- Grafting cord, 219.
- Grafting paper, 219.
- Grafting-wax, 217, (lab.), 284.
- Grafts, wrapping of, 217.

- Grain smuts, prevention of, 282.
 Grasshoppers, 163.
 Green cuttings, 209, (lab.), 284.
 care in making, 210.
 kinds of, 211.
 leaf surface of, 210.
 of herbaceous plants, 211.
 of woody plants, 212.
 Greenhouse, 201.
 heating of, 202.
 Greenhouse plants, rest for, 105.
 Growing point, 43.
 Growth, 7.
 cessation of, 104.
 checking of, 85.
 of roots, 64.
 pruning for, 258.
 retarded, 134.
 after transplanting, 246.
 Growth current, obstructing, 260.
 Growth rings, formation of, 47.
 Guard-cells, 42.

 Hardiness, 5.
 relation to leaf size, 77.
 relation to maturity, 106.
 Head, in fruit-trees, 256.
 pruning for open, 254.
 Healing of wounds, 48.
 Health, 6.
 Heat, effect on evergreens, 110.
 relation to transpiration, 109.
 Heaving, 118.
 Hedge shears, 264.
 Heel, cuttings, with, 206.
 Heeling-in, 237, (lab.), 284.
 Hellebore, 157; keeping of, 159.
 Herbaceous plants, green cuttings
 of, 211.
 method of side-grafting, 224.
 packing for transportation, 234.
 Heredity, 8, 113.
 Hermaphrodite, 94.
 Hotbed, 200, (lab.), 283.
 ventilation of, 62.
 Hot water, as an insecticide,
 162.
 Humidity, controlling of, 204.
 Hybrids, 12.

 Hydrocyanic acid gas, 161.
 Hypocotyl, 25, 28.

 Ice, destruction of plants by, 118.
 Implements, for pruning, 262.
 Improvement of plants, 265.
 Individuals, in relation to species, 9.
 Insecticides, 156.
 application of, 164.
 for sucking insects, 172.
 use of, 167.
 Insect injury, avoiding by grafting,
 215.
 prevention of, 154.
 Insects, burrowing, 168.
 classes of, 167.
 control of, 154, 155, 171.
 depredation by numbers of, 162.
 sucking, 167, 171.
 useful, 154.
 Internodes, 72.
 elongation of cells in, 139.
 length of, 73.
 Irrigation, 136.

 Kerosene, 160.
 emulsion (lab.), 282.

 Labeling of crosses, 272.
 Laboratory work, 275.
 Latent buds, 80.
 Lateral buds, 79.
 Layers, mutilating to encourage
 rooting, 192.
 propagation by, 191.
 Lead arsenate, 156.
 Leaf-buds, 81.
 vigor of, 83.
 Leaf-cuttings, 212, (lab.), 284.
 Leaf development, 76.
 Leaf-eaters, 168.
 Leaf-miners, 170.
 Leaf surface, of cuttings, 210.
 Leaves, function, 75.
 life of, 78.
 manurial value of, 78.
 number of, 76.
 size of, 77.
 structure, 75.

- Legumes, value of, 148.
 Lenticels, 43.
 Lever shears, 264.
 Life, our knowledge of, 4.
 Life history of insects, 172.
 Light, excessive, 137.
 insufficient, 139.
 Lime sulfur, as a fungicide, 181.
 self boiled, 182.
 wash, 160.
 Liquid sprayers, 164.
 Locusts, 163.
- Mallet cuttings, 206.
 Manure, 151.
 organic, 148.
 value of leaves as, 78.
 Maturative pruning, 251, 261.
 Maturity, 105.
 favored by dry soil, 119.
 hastening of, 134.
 in seeds, 99, (lab.), 281.
 Mice, 153.
 Moisture, in air, 133.
 insufficient, 133.
 relation to germination, 17.
 to rooting cuttings, 198.
 to root growth, 59.
 to stored seeds, 101.
 Moles, 154.
 Monocotyledons, 28.
 Monœcious flowers, 94.
 Mound-layering, 191.
 Mulching, 135.
 of newly transplanted plants, 245.
 Mutilation of layers, 192.
- Nitrates, sources of, 147.
 Nitrification, 147.
 Nitrogen, importance of, 146, 147.
 commercial forms of, 148, 150.
 excessive, 144.
 Nodes, and internodes, 72, (lab.),
 281.
 Non-parasitic diseases, 182.
 Non-sexual reproduction, 8.
 Notching, 260, 299.
 Nozzles, 166.
 Nursery trees, 69.
- Observation, 1.
 stimulation of (lab.), 275.
 Œdema, 131.
 Organic manures, 148.
 Organic matter, 61.
 Ovary, 89.
 Overbearing, 97.
 Ovule, 89.
 Oxygen, necessary to root growth,
 59.
 needed in germination, 19, (lab.)
 278.
- Packing herbaceous plants, 234.
 trees, 235, (lab.), 284.
 Palisade cells, 41.
 Parasites, 13.
 classes of, 152.
 lower orders, 174.
 vegetable, 173.
 Parenchyma, 44.
 Paris green, 156.
 Peeling the stem, 260.
 Perfect flowers, 94, (lab.), 281.
 Phosphorus, 149.
 Photosynthesis, 35.
 Picturesqueness, pruning for, 252.
 Pinching, 74, 248.
 fruitfulness, 259.
 of terminal buds, 119.
 to promote flowering, 86.
 to thicken head, 254.
 Pistil, 89.
 Plant-breeders as benefactors,
 273.
 Plant culture, 2.
 Plant disease, control of, 175.
 Plant-food, accumulation of, 85.
 elements of, 37.
 prepared, 54.
 reduction of by cropping, 146.
 reserve, 7, 56, 84.
 sources of, 36.
 Plant processes, relation to rest-
 period, 107.
 Planting, of bulbs, etc., 195.
 of cuttings in autumn, 206.
 of root-cuttings, 208.
 of stem-cuttings, 207.

- Planting, relation to pollination,
 94.
 shallow for small seeds, 28.
 too close, 140.
 with reference to chance crossing,
 273.
- Plantlet, 24, (lab.), 279, 280.
- Plants, improvement of, 265.
 parts used for cuttings, 197.
 pot-bound, 85.
 potted, 63.
 power to endure cold, 113.
 propagation of, 189.
 protection of, 151, (lab.), 282.
 removal of in transplanting, 234.
 shading of, 137.
 under glass, 140.
 unpacking, 237.
 watering, 63, 111.
 water requirements of, 131.
 which can be grafted, 215.
- Plum curculio, 171.
- Plumule, 33.
- Poisons, 156.
 handling of, 157.
- Pole shears, 264.
- Pollen, 89.
- Pollination, 92.
 best time for, 272.
 of emasculated flowers, 272.
 planting with reference to, 94.
 prevention of undesired, 271.
 relation to wind, 143.
- Potassium, 149.
- Potatoes, nobby, 132.
- Pot-bound plants, 85.
- Potted plants, 63.
- Potting, and shifting, 242, (lab.),
 285.
 soil for, 243.
- Prepared food, current of, 54.
- Pricking off of seedlings, 68.
- Prolificacy, 8.
- Propagating-bed, 202, (lab.), 283.
- Propagation, 186.
 by cutting, 196.
 by division, 188, 189.
 by division of crown, 192.
 by layers 191, (lab.), 283.
 by leaf cuttings, 212.
 by parts, detached, 193.
 by sections of plants, 195.
 by seeds, 187, (lab.), 283.
 by specialized bud, 193.
 intact, 189.
 of dormant plants, 204.
 to retain variations, 267.
- Prosenchyma, 44.
- Protection, against cold, 119.
 against mice, 153.
 of newly set trees, 240.
 of pruning wounds, 251.
- Protective pruning, 251, 261.
- Protoplasm, 7.
- Pruning, 248, (lab.), 285.
 for flowers and fruit, 258, 259.
 for growth, 258.
 for open head, 254, 255.
 for stimulation, 251, 257, 258.
 for stockiness or slenderness, 252,
 253.
 for strength, 255.
 for symmetry and picturesque-
 ness, 252.
 implements, 262.
 insufficient, 141.
 knife, 262.
 maturative, 251, 261.
 objects of, 251.
 protective, 251, 261.
 removal of branches in, 250.
 roots, 67, 69, 86, 249, 259.
 saw, 262.
 season for, 249.
 shears, 264.
 wounds, 250, 251.
- Pumpkin seeds, method of plant-
 ing, 26, (lab.), 279.
- Pyrethrum powder, 158, 159.
- Rabbits, 153.
- Rain, value of, 148.
- Raspberry hook, 264.
- Ray-flowers, 91.
- Repair of split tree, 257.
- Repelling insects, 155.
- Replanting, 237.
 of roots, 239.

- Reproduction, 7.
 means of, 8.
 sexual and nonsexual, 8.
 suppression of to stimulate growth, 258.
- Reserve food, 7.
 relation to flower-bud formation, 84.
 storage of, 56.
 use of, 56.
- Resin washes, 161.
- Resistance to disease, 182.
- Rest period, 104.
 occurrence of, 105.
- Restriction of food current, 56.
- Reversion, 266.
- Ring-budding, 229.
- Ringing, 86, 249, 260.
 wood for cuttings, 207.
- Ripening of fruits, 98.
- Rodents, 152, 153.
- Rootcap, 63.
- Root-cuttings, 208, (lab.), 284.
- Root-eaters, 168.
- Root-grafting, 220, 216.
- Root-grafts, storage of, 221.
- Root-hairs, 27, 64, (lab.), 280.
 gathering of food by, 65.
 lost in transplanting, 231.
- Root-killing of trees, 117.
- Root pruning, 67, 69, 249.
 for fruitfulness, 259.
 to form flower buds, 86.
- Root tip, penetration of soil by, 63.
- Root tubercles (lab.), 281.
- Roots, branching of, 67.
 depth in soil, 69, 70.
 destruction of by water, 129.
 growth of, 64, 70.
 horizontal extent of, 69.
 origin of, 58.
 parts of that absorb, 66.
 preparation for replanting, 237.
 pruning, 67, 69, 86, 249, 259.
 puddling in transplanting, 235.
 relation to food supply (lab.) 281.
 replanting of, 239.
- starting of, 27.
 starvation, 55.
 tubercles on (lab.), 281.
- Rosin washes, 161.
- Rotation of crops, 151.
- "Running out" of varieties, 268.
- Sand, 203.
- Sap, elaborated, 54.
 flow in spring, 53.
- Sap-sprouts, 132.
- Sap-wood, 53.
- "Saucer system" for green cuttings, 211.
- Scale insects, 172.
- Science, 1.
 means of gaining, 2.
- Scientific names, 11.
- Scion, see *Cion*.
- Scraping, 261.
- Screens, 138.
- Season for pruning, 249.
- Seedcase, 16.
 bursting of, 26, 27.
 cracking, 22.
 in germination, 25.
- Seeding, 97, 98.
- Seedlings, for root-grafting, 220.
 growing of for variations, 269.
 parts of, 34.
 pricking off of, 68.
 vigorous, 30.
- Seeds, absorption of water by, 14, 15, (lab.), 278.
 age of affects crop, 102.
 depth of planting, 30, (lab.), 279.
 effect of drying, 102.
 exhausting plant by, 96.
 hastening germination of, 21.
 immature, 99.
 means of propagation, 186.
 rules for planting, 187.
 selection, 268.
 size of, affects vigor of plants, 29, (lab.), 280.
 storage of, 101.
 stratification of, 103.
 study of, 276.
 surface planting of, 31.

- Seeds, treatment, 177.
 viability of, 16, 17, 100.
- Seed-testing, 23.
- Selection, of crossed seedlings, 273.
 of seeds, 268.
 principle of, 9, 266.
 to fixed type, 267.
- Self-boiled lime sulfur, 182.
- Sepal, 88.
- Shading of plants, 137, 245.
- Shifting, 242.
- Side-grafting, 223, (lab.), 284.
- Size of seeds, 29.
- Slenderness, pruning for, 254.
- Sling psychrometer, 122.
- Slips, 209.
- Snow, value of, 148.
- Soil, adapting varieties to by grafting, 215.
 aëration, 63, 147.
 changes in, 61.
 compacting, 21.
 contact with roots in replanting, 239.
 for potting, 243.
 ideal, 61.
 penetration by root tip, 63.
 sterilization, 176, 177.
 treatment, 176.
 ventilation, 62.
- Spatula, 228.
- Species, 10.
- Sphagnum moss, 203.
- Spikelet, 91.
- Splitting of wood, 116.
- Spores, 31.
- Sprayers, 164.
- Spraying, 178.
- Spray pumps (lab.), 282.
- Sprays, mixing of, 181, 182.
- Sprinkling, of plants in sunshine, 111.
- Sprouting, 249.
- Stamens, 88.
- Starch, as reserve food, 56.
- Steam sterilization of soil, 177.
- Stem, 72.
 increase in diameter of, 47.
 lengthening of, 73.
 living part of woody, 48.
 region of fastest elongation, 74.
 underground, 72, (lab.), 281.
- Stem-cuttings, 206, (lab.), 283.
- Sterility, in relation to hybrids, 12.
- Sterilization of soil, 177.
- Stigma, 89.
- Stimulation, by pruning, 251, 257, 258.
- Stock, 214.
- Stockiness, pruning for, 253.
- Stock solutions, 181.
- Stolons, 189.
- Stomata, 42.
- Storage, for cuttings, 205.
 of reserve food, 56.
- Stratification of seeds, 103, (lab.), 282.
- Strength, pruning for, 255.
- Structure of plants, 40.
- Style, 89.
- Suckering, 249.
- Suckers, 189.
 propagating woody plants by, 190.
- Sucking insects, 167, 171.
- Sulfur, as a fungicide, 182.
- Sunscald, 111, (lab.), 282.
- Symmetry, pruning for, 252.
- T-budding, 226.
- Temperature, control of for cuttings, 198.
 effect on absorbing power of roots, 66.
 fatal to plants, 110.
 for germination, 17, 21.
- Tenderness, 5.
- Terminal bud, 83.
 destruction by cold, 115.
- Thawing, rate affects injury by freezing, 113.
- Thermal belts, 127.
- Thinning of fruit, 97, 249.
- Tip-burn, 112.
- Tobacco, frenching of, 131.
 smoke, 159.
 solutions, 159.
- Tongue-grafting, 219, (lab.), 284.
- Top working, 220, 223.

- Top-grafting, 220, 223.
Topiary work, 253.
Topping, 248.
Toughness, of plant tissues, 134.
Transpiration, 51.
 current, 52.
 excessive, 133.
 in cuttings, 198.
 relation to heat, 109.
 stimulated by light, 137.
Transplanting, 231.
 beneficial to nursery trees, 69.
 devices for, 240, 241.
 influence on root growth, 67,
 (lab.), 281.
 lifting of plants in, 233.
 machine for, 242.
 puddling roots in, 235.
 reduction of top in, 238.
 sacking of roots in, 234.
 tardy starting of growth after,
 246.
 time for, 231.
Trapping of insects, 155.
Treatment, of seed, 177.
 of soil, 176, 177.
Trees, care of split, 257.
 girdled, 215.
 influence on crop, 52.
 lifting of, 233.
 protection of newly set, 240.
 raising and lowering of, 233.
 repair of, 257.
Trimming, 248.
 of roots, 237.
Tuber, 195.

Underground stems, 72.
 study of (lab.), 281.
Unpacking plants, 237.

Variability, 266.
Variation, 8.
 desirable, 267.
 fixing of, 267.
 in hybrids, 12.
 methods of inducing, 268.
Varieties, "running out" of, 268.
Vascular bundles, 43, (lab.), 280.

Vegetable parasites, 173.
Veneer-grafting, 224.
Ventilation, of hotbeds, 62, 201.
 of soil, 62.
Viability of seeds, 16, 17.
 conditions affecting duration of,
 100, 101.
Vigor, 4.
 of leaf-buds, 83.
 relation to size of seed, 29.
Vitality of seeds, affected by drying,
 102.
 by age, 100, (lab.), 282.

Warmth, relation to germination, 21.
Washing, of roots in replanting, 237.
Water, excessive, 129.
 in plants, 50, 53.
 necessary to growth, 38.
 relation to freezing, 113, 126.
 requirements of plants, 131.
 supply for fruit-bud formation, 84.
 toughness, 134.
Watering, effect of injudicious, 130.
 of plants in sunshine, 111.
 of potted plants, 63.
 of transplanted trees, 240.
 proper methods, 130.
 trees after planting, 245.
Water-sprouts, 132.
Weather, use of in predicting frost,
 123.
Weeds, 140, 143, 183.
 annual and biennial, 184.
 destruction of, 56, 184.
Whip-grafting, 219.
Whole-root grafts, 221.
Wind, insufficient, 142.
 damage by, 141.
Windbreaks, 120.
Winter protection of plants (lab.),
 282.
Wood, ashes, 150.
 darkening of, 115.
 splitting of, 116.
Woodchucks, 154.
Woody plants, green cuttings of, 212.
Wounds, healing of, 48.
 protection of, 251.

THE following pages contain advertisements of
Macmillan books on kindred subjects.

The Nursery Book

A Complete Guide to the Multiplication of Plants

By L. H. BAILEY

New edition. Cloth, 365 pp., ill., 12mo, \$1.50

This admirable volume has become the standard work of reference for nurserymen. It is now thoroughly revised and greatly extended.

Plant Breeding

By L. H. BAILEY

NEW EDITION. REVISED BY A. W. GILBERT

Illustrated. Cloth, 12mo, \$2.00

The original foundation for this book is Professor Bailey's standard text, *Plant Breeding*, first published in 1895. As now issued, the material in the old volume has been thoroughly revised and brought down to date. New discussions of mutations, Mendelism, heredity and the recent applications of the breeding of plants are all included. The work is now adapted to the classroom as well as to the needs of the general reader.

THE MACMILLAN COMPANY

Publishers

64-66 Fifth Avenue

New York

The Spraying of Plants

A Succinct Account of the History, Principles, and Practice of the Application of Liquids and Powders to Plants for the Purpose of Destroying Insects and Fungi

By E. G. LODEMAN

Cloth, 12mo, \$1.25

The only complete and historical discussion of this most important subject. Full particulars are given regarding the materials and formulæ used in spraying plants for the destruction of insects which prey upon them, and for the prevention of parasitic fungi; spraying apparatus and specific directions are given for spraying cultivated plants, with a chapter on the law regarding spraying with poisons.

The Survival of the Unlike

A Collection of Evolution Essays Suggested by the Study of Domestic Plants

By L. H. BAILEY

New edition. Ill., cloth, 12mo, \$2.00

To those interested in the underlying philosophy of plant life, this volume, written in a most entertaining style, will prove welcome. It treats of the modification of plants under cultivation, and incidentally gives much that is suggestive and valuable to the working horticulturist.

THE MACMILLAN COMPANY

Publishers

64-66 Fifth Avenue

New York

New Creations in Plant Life

By W. S. HARWOOD

Second edition. Cloth, ill., 12mo, \$1.75

The first authentic account of the really wonderful experiments with plant life conducted by Mr. Luther Burbank in California. The book is rich in suggestions for the flower, fruit or vegetable grower. The new edition brings the information up-to-date.

Elementary Biology: Plant, Animal, Human

By JAMES EDWARD PEABODY AND ARTHUR
ELLSWORTH HUNT

Cloth, ill., 12mo, \$1.25

A complete elementary treatment of biology emphasizing the relation of biological science to human welfare.

Diseases of Economic Plants

By F. L. STEVENS AND J. G. HALL

Cloth, ill., 12mo, \$2.00

A work designed to meet the needs of those who wish to learn to recognize and treat plant diseases without the burden of long study as to their causes. It indicates the chief characteristics of the most destructive plant diseases of the United States, and gives information regarding the best methods of the prevention and cure of these diseases.

THE MACMILLAN COMPANY

Publishers

64-66 Fifth Avenue

New York

Plant Physiology

With Special Reference to Plant Production

BY DR. B. M. DUGGAR

Cloth, ill., 12mo, \$1.60

In this book the author discusses the life relations of plants and crops from a fundamental point of view. The important physiological activities of the plant are demonstrated experimentally, and the practices of the crop-grower are reviewed from this standpoint. Some of the special topics that are considered are as follows: The relation of the plant and the crop to water; the relation to soil nutrients, stimulants, and inhibiting agents; the relation to light and air; the relation to heat and cold; the relation to the disease environment.

The Diseases of Tropical Plants

BY MELVILLE THURSTON COOK, PH.D.

Decorated cloth, ill., 8vo, \$2.75

This work calls attention to some of the most common, most widespread, and most destructive diseases of tropical plants, as well as certain diseases of the temperate zones not well known in the tropics. It gives a practical knowledge of plant diseases in general and their causes and the most common remedies and methods of prevention.

THE MACMILLAN COMPANY

Publishers

64-66 Fifth Avenue

New York

