

SF
531
.7
P4W

 Cornell University Library

Wintering bees in four-hive boxes.



3 1924 003 482 118

mann

WINTERING BEES IN FOUR-HIVE BOXES

EXPERIMENT No. 10.

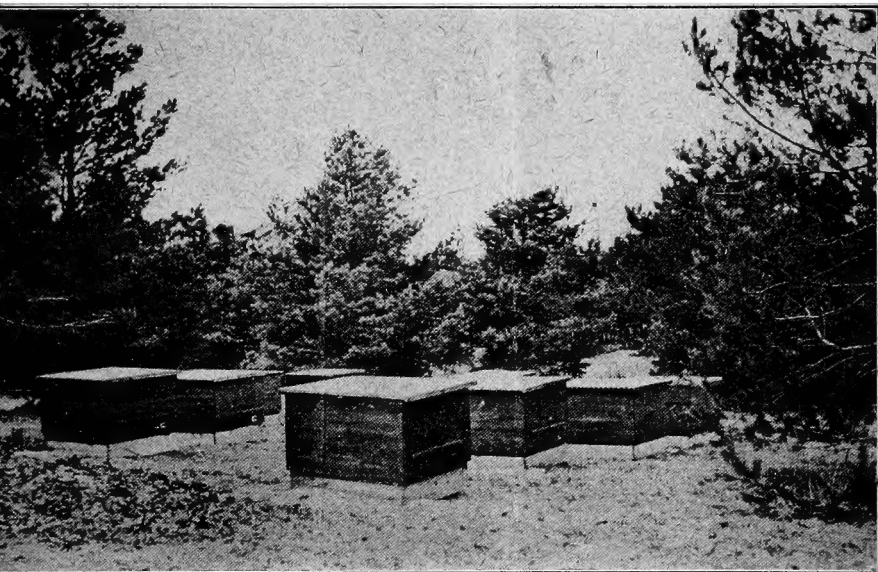

ONTARIO AGRICULTURAL AND EXPERIMENTAL UNION

APICULTURE DIVISION

Director, MORLEY PETTIT

--

CUELPH, ONTARIO

SF
531
.7
P4W

E10851

WINTERING presents one of the greatest difficulties of beekeeping. The method described here has proved successful in the hands of some expert beekeepers. Try it and let us have your results.

Morley Pettit,

Provincial Apiarist,

Guelph, Canada.

WINTERING BEES IN FOUR-HIVE BOXES

MORLEY PETTIT

PURPOSE OF CO-OPERATIVE EXPERIMENTS.

There is nothing on the farm which requires so little care in proportion to the returns as the bees. This is why they are so often kept at a loss; because the care they need is so small that it is utterly neglected. They require only a little attention, but what they do require they must have.

It is to call attention to this work, and to help fit it into its proper place among the other farm duties, that these co-operative experiments are undertaken. They are called "experiments," but the methods of management described have already been proven a success.

It is farthest from the purpose of this work to induce people to start beekeeping without carefully counting the cost. There are already at least ten thousand beekeepers in Ontario. What is needed is not more beekeepers, but better beekeeping. Besides giving bees their proper place on the farms where they already exist, it is hoped that the specialist will be helped to organize his work so as to enable him to keep more bees and also get better average returns.

HOW TO CONDUCT EXPERIMENT No. 10.

First read carefully the directions given in the following pages. Then go to the apiary and select the experimental group of eight hives following directions carefully. Colonies having old or failing queens may be requeened by purchase of queens almost any time up till November first. Weak colonies occupying less than five to six Langstroth combs in September, should be united by setting one over the other with a newspaper between, then sorting the combs down to one broodchamber in four or five days. Moving hives for grouping or uniting should be done gradually one or two feet at a time, with at least one day when bees fly freely between moves. Supers should all be removed before the middle of September. Queen excluders are taken off at the same time and the top bars scraped free of propolis and burr-combs with a hive tool, hoe or some such tool. Bees may be packed at any time after the supers are off; but feeding for winter should be delayed until the first week in October.

After choosing the experimental group, and preparing it as far as possible, queens should be ordered, if necessary,

and best quality granulated sugar for feeding,—to be on the safe side 100 pounds for the four colonies of Lot A. Then unless you are a carpenter, as every beekeeper should be, take the specifications for the winter box to a mill man and order the lumber. Cheaper lumber may be used later; but for the experimental box first class tongue and groove flooring or siding is best.

CHOOSING EXPERIMENTAL GROUP.

The Experimental group should be chosen at the time of taking off supers, or earlier if possible. It takes eight colonies for the experiment. These should be as nearly uniform as possible in every way.

They should all have the same quantity of bees, and of nearly a uniform age. The proportion of young bees in each hive should be as great as possible.

They should all belong to the same race of bees and be good tempered. Vicious colonies should never be tolerated in an apiary; but when it comes to wintering they are particularly liable to loss through being restless.

The queens should all be of the same age, or where they have been introduced from some other source, they should have been put in about the same time. Young vigorous queens are of course the best.

The hives should all be of the same make, or, at least, the same dimensions, with the same space under and over the frames.

There should be the same proportion of drone to worker comb in all the brood-chambers, and it should be small.

Bottom-boards should all be loose from the hives so the entrances and the space under the frames can be properly enlarged.

The hives or outside cases if painted, should all be about the same color, should face half east and half west and have the same exposure to wind, sun or rain.

The apiary should be on dry ground, well sheltered from cold winds. If there is no good natural windbreak, an eight foot tight board fence should be erected all around, or at least on the coldest sides.

Neatness should be observed in all apiary arrangements.

GROUP DIVIDED.

Divide the experimental group into two equal lots. Mark a large A on the hives of one lot and B on the hives of the other lot. Uniformity that could not be obtained amongst individual hives can be secured by making the lots uniform, having in each the same number of old and young queens, etc.

Now prepare the colonies of lot B just as you would have prepared the whole apairy if you had not heard of co-operative experiments in apiculture. Any change in your management of them will spoil the experiment, as it will not give a fair comparison between your way of managing and ours. This does not mean that you are to neglect them any more than usual. If your method of out-door wintering is better than ours, you are requested to prove it by testing the two side by side; but if you feel that our way is better you should risk four hives by the old way to see how much better. The colonies of lot A are to be managed according to instructions given below.

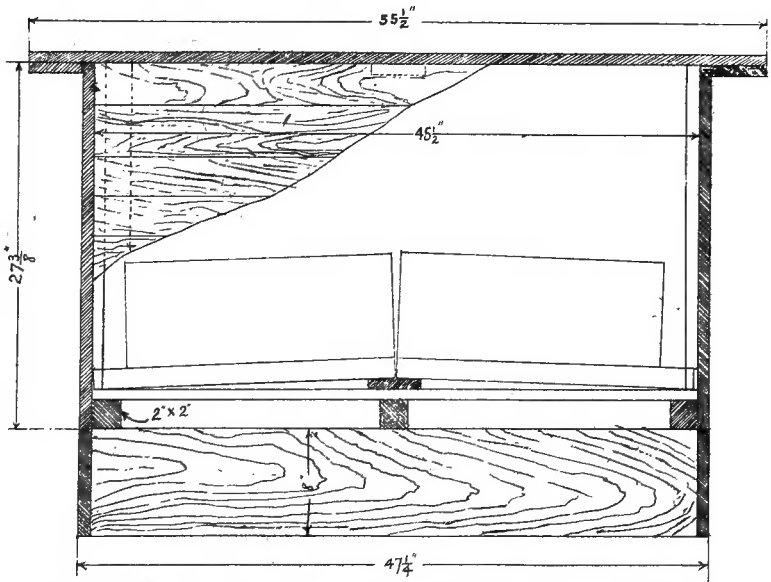

Figure 1—Side elevation of 4-hive Wintering Box, with side cut away to show construction.

MANAGEMENT OF LOT A.

The four hives of Lot A are placed tightly together in one box two facing east and two west. This box provides

for about 3 inches of packing on all sides of the four hives, and 8 or 10 inches on top. There is no packing between the hives or under them. The entrances open out through the sides of the box so the bees are always able to fly when weather permits. They are packed up as soon as possible after supers are off, then fed all the sugar syrup they will take early in October.

THE HIVES.

The size of the box will depend on the dimensions of the hive used. The 10-frame Langstroth hive as made in Ontario is 20 inches long, $16\frac{5}{8}$ inches wide and about $9\frac{1}{2}$ inches deep. The bottom-board is $22\frac{1}{2}$ inches long and $11\frac{3}{4}$ inches deep. These are outside measurements. The space inside the bottom-board is $\frac{5}{8}$ inch deep. If the frame-rests in these hives are so arranged that the tops of the frames are even with the tops of the hives, that is, if the bee-space is underneath the frames, the space between the bottom-bars and the floor of the bottom-board will be about one inch, which is sufficient for wintering. If however, the bee-space is above the frames, and the bottom-bars come even with the bottom of brood-chamber the space will be only $\frac{3}{8}$ of an inch and should be increased by tacking half inch strips on the rim of the bottom-board all around or by using the wedges which are frequently used to enlarge the entrance for swarm control in summer. The entrance of the hive is left full width and this extra depth all winter. The projecting bottom-board is bridged over by means of a piece of $\frac{3}{4}$ inch board, $2\frac{1}{2}$ inches wide and $16\frac{5}{8}$ inches long, laid flat and extending from one side rim to the other so as to make a tunnel from the entrance of the give to the flight hole in the end of the box. After all four hives have been fixed in this way they are ready to put into their box.

THE WINTERING BOX AND STAND.

The wintering box consists of the floor, two ends, two sides and the roof, all finished with cross cleats so that each is a separate piece which can be taken down and piled flat with the others when not in use. Seven-eighth inch matched lumber is used throughout. The sides and ends are placed outside the floor to turn the rain, and are supported by the corner cleats which rest endwise on the corners of the floor. The inside dimensions of the box are $24\frac{1}{2}$ inches deep, 40 inches wide and $45\frac{1}{2}$ inches long. It has a flat roof projecting 4 inches on all sides and covered with prepared roofing. This box is placed on a stand about 8 or 10 inches high, made of four boards $\frac{7}{8}$ inch by 8 or 10 inches, nailed into a rectangle. The ends are cut 40 inches and the sides $45\frac{1}{2}$ inches long.

They are nailed up with the shorter pieces nailed on the ends of the longer ones, and the outside dimensions of the resulting stand are 40 inches by $47\frac{1}{4}$ inches. To make the floor of the wintering box, first lay down three pieces each 2 inches square by 40 inches long; then nail on these $\frac{7}{8}$ inch matched lumber, cut $45\frac{1}{2}$ inches long, making the floor 40 inches by $45\frac{1}{2}$ inches. It will be seen that when this floor is laid on the stand it comes just even with it at the sides, but is $\frac{7}{8}$ inch short of it at each end. In other words, the outside of the stand and the wintering box are the same, making a smooth surface from the ground up, where the bees have their flight holes, but the stand is made narrower as a convenient way of supporting the cross cleats of the floor. After the stand, with the floor in place, is levelled up with a spirit level using scraps of thin lumber under the corners, a board $\frac{7}{8}$ inch by 4 inches by 36 inches is laid flat across the middle of the floor to support the backs of the four hives giving them a tilt forward toward the ends of the box. The four hives are placed close together with the four corners meeting at the exact centre of the floor. The front ends of the bottom-boards will then come just about to the edges of the floor and should almost touch the ends of the box when it is put in place.

The wintering box is made $24\frac{1}{2}$ inches deep inside so the hives can be supered, if necessary, before they are unpacked. As the outside dimensions of the floor are 40 inches by $45\frac{1}{2}$ inches, these will be the inside dimensions of the box whose sides and ends must project down over the floor about $2\frac{7}{8}$ inches to cover it and its cross supports and leave no opening between it and the stand. Each side and each end of the box will need an upright at each end of it, $\frac{7}{8}$ inch by 2 inches by $24\frac{1}{2}$ inches, and if these are all placed $\frac{7}{8}$ inch back from the end of the lumber a locked joint will be formed which will not admit dampness (See Fig. 3). The sides of the box are $45\frac{1}{2}$ inches long by $27\frac{3}{8}$ inches high. The ends would be 40 inches plus $\frac{7}{8}$ inch at each end to cover the ends of the sides against which they are clamped or nailed, or $41\frac{3}{4}$ inches long by $27\frac{3}{8}$ inches high. When these two sides and two ends are made up and placed together, the outside dimensions of the box thus formed will be $41\frac{3}{4}$ inches by $47\frac{1}{4}$ inches.

After the ends are made up the entrance holes should be cut. These must come opposite the hive entrances and should be as deep as the bridge will allow but need not be the full width. They are placed as far apart as possible to prevent bees mixing when they fly. Measuring 6 inches in

from each end and $3\frac{5}{8}$ inches up from the lower edge of the box end locates the lower outer corners of the two entrances. The holes are then cut four inches long horizontally, and $1\frac{1}{2}$ inches high. In cold weather each is reduced to a vertical entrance $\frac{3}{8}$ inch by $1\frac{1}{2}$ inches by means of a piece of thin board $2\frac{1}{2}$ inches by 8 inches fastened with a screw or an ordinary wire nail on which it turns as on a pivot. When closed down it comes $\frac{3}{8}$ inch short of closing the opening leaving the $\frac{3}{8}$ inch by $1\frac{1}{2}$ inches vertical entrance. A nail driven just below it prevents its coming down too far. When raised up the opening is full size for cleaning out dead bees, or for ventilation on hot days in spring or autumn. The vertical entrance is less liable to clog with dead bees or ice than a horizontal one would be.

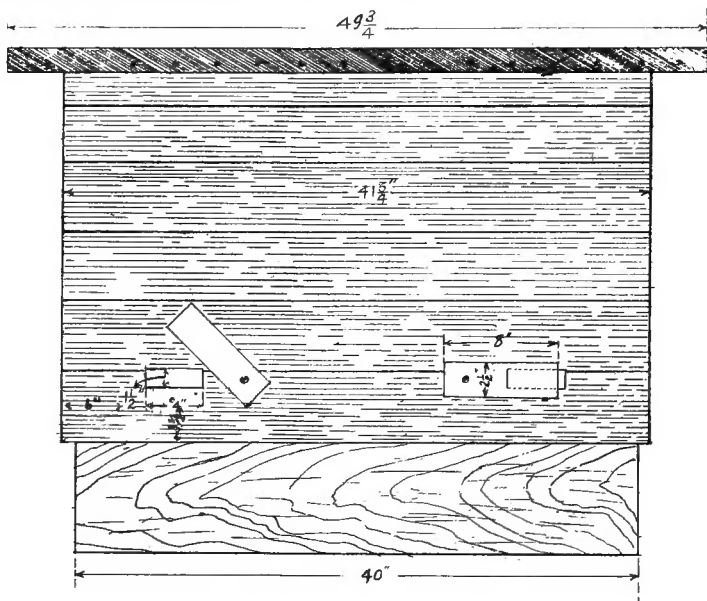

Figure 2 - End Elevation of 4-Hive Wintering Box, showing arrangement of Entrances.

The roof is made perfectly flat and large enough to project 4 inches on all sides. That is, it is $49\frac{3}{4}$ inches by $55\frac{1}{2}$ inches, allowing $\frac{1}{4}$ inch for play. It is made of $\frac{7}{8}$ inch lumber with a 4 inch cross piece of the same material at each end and in the middle. The middle cross piece should be just 40 inches long to fit inside the box; the end cross pieces fitting outside and forming a telescope projection $\frac{7}{8}$ of an inch deep to prevent dampness from drawing in underneath.

The cover should fit closely enough to exclude mice, but should have openings underneath sufficient for the air to draw through over the packing and take away moisture arising from the bees. This cover is overlaid with prepared roofing.

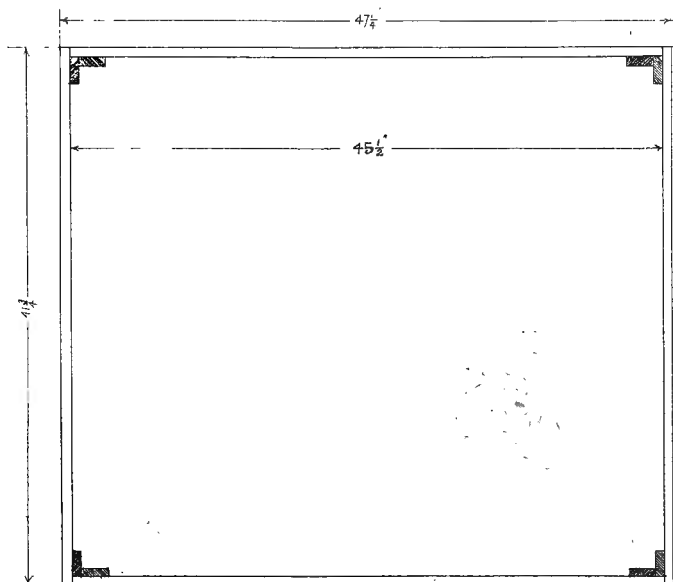

Figure 3—Outline of 4-Hive Wintering Box showing weather proof joint at corners.

PACKING THE HIVES.

When the four hives are in place with bridges on, the sides and ends of the box are set up and fastened at each corner with three clamps, hooks or wire nails. The bridges must fit closely to prevent packing material clogging entrances. If the bees can reach this material at all they will dig out quantities of it and perhaps choke their own entrance. The summer cloths or honey-boards are next removed and replaced by feeder-boards (to be described later) with burlap spread over them and two or three thickness of newspaper over that. The packing is then filled in and crowded down well on all sides until the box is filled to within two inches of the top. At no time must this material touch the roof. The air must circulate freely over it to prevent dampness collecting.

The best packing material is cork chips, which can sometimes be obtained from fruit stores handling Spanish

grapes. Forest leaves are excellent, and planer shavings, or chaff are good; but sawdust, clover chaff or anything which draws and holds dampness should be avoided. Some use straw, but it is too open and cold unless cut fine.

FEEDING FOR WINTER.

At all times during summer and early autumn care should be taken to see that colonies do not starve. So long as they have enough for daily food winter feeding should be delayed until the first half of October. For the experiment, each hive of Lot A must be given all the syrup it will take. This may be anywhere from 10 lbs. to 40 or 50 lbs., depending on the strength of the colony and the amount of stores it already has. The syrup is made of two parts best granulated sugar to one of water. Boil the water then add the sugar and stir till thoroughly dissolved. The only points to be observed are to avoid scorching the sugar and to see that no granules are left in the syrup to start crystalization after it has been stored in the combs. The feeder consists of the feeder-board and three atmospheric feeders. The board is made of $\frac{3}{8}$ inch lumber cut $16\frac{3}{8}$ inches by 20 inches to fit the hive like a honeyboard. Three circular holes $2\frac{1}{2}$ inches in diameter are made in it for the feeders with key-hole saw or extension bit. When in place there must be a bee-space over the frames. If the hive does not provide this a $\frac{3}{8}$ inch rim is nailed to the board. The feeders are two quart fruit jars covered with cheese cloth held on by the ring, or ten pound lever cover honey pails with a number of small holes punched in the lids. When these are filled and inverted over the holes in the feeder-board, atmospheric pressure prevents any leakage, and the bees take the syrup through the cloth or perforations and store it in the combs.

When feeding time comes in the early part of October, the packing is removed from over the feeder-boards and three filled pails or jars are inverted over the three holes. If the days are warm this is done towards evening to prevent robbing, and if the nights are cool packing is put around the feeders to hold the brood-chamber heat and help the bees take down the feed. As fast as feeders are emptied they should be refilled, until the bees signify that they have enough by ceasing all work on the feeders. The latter are then removed, the burlap, paper and packing are replaced, and the roof is adjusted for the winter. The feeding may take a week or more in cool weather, but should be gotten through with as rapidly as possible after it is once started.

If these directions have been followed carefully the bees of Lot A will require no further attention until spring. In

fact, some extensive beekeepers prepare all their bees in a similar manner, then go to the city and do not see them again till May. It is better, however, to visit the apiary frequently, not to disturb the bees in any way, but to see that no accident has happened, such as fence blowing down, covers off, etc. When a warm day occurs towards spring, and the bees are flying, the entrance doors should be raised and dead bees raked out with a wire. Snow drifting over the box may do no harm, but uniformly good results are obtained by not allowing it to be higher than the entrances around the box. A form will be sent to experimenters for the report comparing results from wintering bees by the method described here and by the usual method.

All communications should be sent to

MORLEY PETTIT,

Provincial Apiarist,

GUELPH, ONTARIO.



