

SF  
531  
.55  
S7

# Queen-Rearing in England.

SECOND EDITION.



CORNELL UNIVERSITY

LIBRARY

NEW YORK STATE  
COLLEGE OF AGRICULTURE



EVERETT FRANKLIN PHILLIPS

BEEKEEPING LIBRARY

Cornell University Library

**Queen-rearing in England, with notes on a**



3 1924 003 552 704

mann

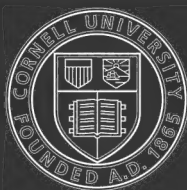

# Cornell University Library

The original of this book is in  
the Cornell University Library.

There are no known copyright restrictions in  
the United States on the use of the text.

QUEEN-REARING IN ENGLAND.





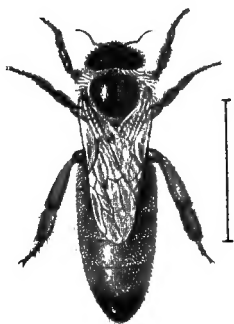

Golden Prolific  
Queen-Bee.

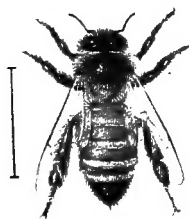

"Extra Golden"  
Worker-Bee.

SLADEN'S  
"BRITISH GOLDEN"  
BEE

*The lines indicate the actual lengths*

(Copyright.)



# QUEEN-REARING IN ENGLAND

WITH NOTES ON

A SCENT-PRODUCING ORGAN IN THE  
WORKER-BEE

AND

HOW POLLEN IS COLLECTED BY  
THE HONEY-BEE AND BUMBLE-BEE

BY

F. W. L. SLADEN

Fellow of the Entomological Society of London,  
Asst. Entomologist for Apiculture, Division of Entomology,  
Department of Agriculture, Canada;

Author of *The Humble-Bee*.

SECOND EDITION

LONDON:

MADGWICK, HOULSTON & CO., Ltd., 4, AVE MARIA LANE, E.C.

1913.

E 607

## PREFACE.

The writer, devoted to bees from boyhood, started life with the intention of earning his living from them. Like many other enthusiasts, he kept an apiary and sold the honey. He established an out-apiary. He sold all the honey he could produce at a good price, and in order to satisfy the demand for more he had to go to other bee-keepers for help. But, while it was easy by these means to earn sufficient to maintain himself, the uncertainty of the British climate made it impossible for him to support a family as well, which was his next ambition. He was also possessed with a longing to become still more intimate with his bees. Was it possible for these two desires to be attained? Yes. Fully, and more than fully were they gratified by taking up BEE-BREEDING and specialising in QUEEN-REARING.

The notes gathered together in this little volume are the result of about fifteen years' experience in developing and managing a queen-rearing apiary as a commercial undertaking on the coast of Kent. Most of the operations described are well-known and widely practised in America, but many of them, together with the appliances employed, are modified to meet the requirements of the British climate, and some of the details are new. The bees employed were chiefly British Goldens and Golden-English hybrids, the behaviour of which probably differs in some few details from that of pure blacks or pure Italians.

American queen-breeders will detect evidences of less favourable weather conditions than their own on almost every page; yet perhaps they will find the book worth perusal, for a trying climate teaches useful lessons.

"Queen-rearing in England" originally appeared in the *British Bee Journal* in March and April, 1904. The next year it was revised and published in book form. The first edition being now exhausted, the opportunity has been taken to rewrite the book; it is now considerably larger than the former edition, much new matter having been added.

The chapter on breeding for improvement consists chiefly of a lecture given by the author on "Mendelian Methods applied to Apiculture" at the Zoological Gardens, London, on September 10th, 1912, under the auspices of the British Bee-Keepers' Association.

The original article on "A Scent-producing Organ in the Abdomen of the Worker Bee" appeared in the *British Bee Journal* of April 11th and 18th, 1901, and that on "How Pollen is Collected by the Honey-bee and Bumble-bee, and the part played in the process by the Auricle" in the *B.B.J.* of December 14th, 1911. Both of these papers described, apparently for the first time, the true function of important specialised organs in the worker-bee, and as they are of general interest it has been thought advisable to reproduce them, with a few alterations and additions, as an appendix to the book.

The figures illustrating the text are from drawings and photographs by the writer. Some of them were made to illustrate the original articles in the *British Bee Journal*; others are now appearing for the first time. The drawing of the legs of the honey-bee, shown at Fig. 37, originally appeared in the *Canadian Bee Journal* for July, 1912. The *British Bee Journal* has kindly supplied the blocks of Figs. 3, 5, 6, 16, 17, 22, 24, 25, 29, 30, 31 to 35, 38 to 41, 43, and 44.

The hum of the bees in Ripple Court Apiary is no longer heard by the author, who has entered a wider field of bee work in Canada, but he looks back with pleasure to the happy years spent in that rural spot in the old country, and he takes this opportunity of thanking the British bee-keepers for the generous support they accorded him while there.

F. W. L. S.

Ottawa, Canada.

February 28th, 1913.



[Photo by H. Franklin & Son, Deat.

MR. F. W. L. SLADEN'S FORMER HOME AT RIPPLE, NEAR DOVER. BUILT FROM THE PROFITS DERIVED FROM BREEDING BEES AND QUEENS IN RIPPLE COURT APIARY.



## CONTENTS.

	PAGE
I.—INTRODUCTION ... ..	1
II.—QUEEN-REARING IN NATURE ... ..	2
Queen-Rearing under the Swarming Impulse ...	2
Queen-Rearing to Supersede a Failing Queen ...	4
Queen-Rearing when the Queen is Accidentally Lost ... ..	4
Approximate Duration of Stages in Development of a Fertile Queen-Bee ... ..	4
III.—HOW TO SAVE QUEENS REARED UNDER THE SWARMING IMPULSE ... ..	5
IV.—MODERN QUEEN-REARING ... ..	7
V.—REARING THE QUEENS ... ..	7
Preparing the Cups ... ..	8
Renovating the Cups ... ..	10
Rearing the Queens in a De-queened Colony ...	10
Transferring the Larvæ ... ..	11
Rearing Second and Third Batches of Queens in a De-queened Colony ... ..	16
Combining Queen-Rearing with Artificial In- crease ... ..	17
Rearing Queens in a Colony that is Superseding its Queens ... ..	17
Rearing Queens in a Colony Containing an Ordinary Fertile Queen in a Compartment from which the Queen is Excluded ... ..	18
Methods of Starting the Queen Cells ... ..	20
Other Methods of Raising Queens in a Colony containing a Fertile Queen ... ..	22
Recording Notes ... ..	22
VI.—INCUBATING THE QUEEN-CELLS ... ..	23

	PAGE
VII.—NUCLEI AND FERTILISATION OF QUEENS...	28
Nucleus Hives ... ..	28
Forming Nuclei ... ..	31
Buying Bees to make Nuclei .. ..	36
Fertilisation of the Queen ... ..	36
Drone-Breeding Queens ... ..	39
Management of Nuclei ... ..	40
Baby Nuclei ... ..	42
VIII.—SENDING QUEENS BY MAIL AND INTRODUCING THEM TO COLONIES ... ..	44
Sending Queens by Mail ... ..	44
Queen Candy ... ..	46
Introducing Fertile Queens ... ..	46
Introducing Cage for Pressing into Comb ... ..	46
Candy Introducing Cage ... ..	47
IX.—RACES OF BEES ... ..	48
1. The British Black Bee ... ..	49
2. The Italian Bee ... ..	49
3. The Carniolan Bee ... ..	50
4. The Cyprian Bee ... ..	50
5. The Caucasian Bee ... ..	51
X.—DRONES AND DRONE-REARING .. ..	51
XI.—BREEDING FOR IMPROVEMENT ... ..	53
Crossing and Selection ... ..	53
Mendelism ... ..	54

## APPENDIX.

A SCENT-PRODUCING ORGAN IN THE ABDOMEN OF THE WORKER HONEY-BEE ... ..	73
HOW POLLEN IS COLLECTED BY THE HONEY-BEE AND BUMBLE-BEE ... ..	77



# Queen-Rearing in England.

---

## I.—INTRODUCTION.

The queen being the mother of all the bees in the hive, the bee-keeper finds a supply of queens to be very valuable. He can build up fresh colonies with them, and he can save, or improve, colonies that already exist by introducing young and vigorous queens to those that have lost their queen, or to those in which the laying power of the queen has become impaired through old age. Thus the population of the apiary and its yield of honey can be greatly increased.

Another and more important purpose of queen-rearing is the improvement of the bee. The methods by which domestic animals and cultivated plants have been rendered more useful or more beautiful in the estimation of man, namely, breeding by selection and crossing selected races and varieties, may be applied to bees. In breeding bees for improvement some of the greatest problems in bee-culture, such as disease-resistance, the increase of honey-yield, the improvement of temper, and the reduction of swarming, have been attacked. This important subject is dealt with in Chapter XI.

Bee-keepers who are unable to devote the time and attention to queen-rearing that it needs will find a good and simple method of obtaining a few queens described in Chapter III., which has been made as much as possible complete in itself.

The frame for combs mentioned in this book is the standard frame of the British Bee-keepers' Association (outside dimensions,  $8\frac{1}{2}$  in. deep by 14 in. long, with top bar 17 in. long, which is used throughout the British Isles). Most of the remarks, however, apply equally well to the sizes of frames that have been adopted as standard in other countries. It is advisable to have all the combs which are used in the queen-rearing apiary built from full sheets of foundation wired into the frames.

## II.—QUEEN-REARING IN NATURE.

Queens are reared in Nature under three different conditions:—(1) When a colony is about to swarm; (2) when the queen is failing; and (3) when, through accident, the queen suddenly dies or gets lost.

**Queen-Rearing under the Swarming Impulse.**—In May or June, when the hive is crowded with bees, and there are a large number of young bees being reared, about a dozen queen cells, resembling inverted cups, are formed in the brood-nest, chiefly on the side and bottom edges of the combs. In some colonies these queen cells are, after a time, destroyed, and no swarm eventually issues, but, in others, the queen sooner or later deposits an egg in each queen-cell. If the colony continues to prosper the egg is allowed to remain, and after three days a larva hatches from it.

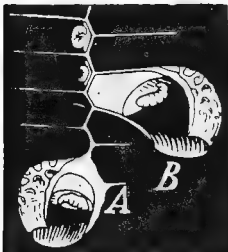

Fig. 1.  
Diagram showing (A)  
Queen-cell built under  
swarming impulse, and (B)  
Queen-cell built after loss  
of queen.

The larva is supplied by the worker bees with a quantity of opaque white jelly, resembling flour paste, called "royal jelly," on which it floats and feeds (Fig. 1, A). At first the amount of royal jelly supplied to the larva is small, but it is soon greatly increased, and there is always much more of it than the larva can consume. Dufour and Schönfeld have shown that the royal jelly is produced in the chyle-stomach.\* It has, therefore, been

named chyle-food. It is chiefly produced by the young bees, which remain in the hive while the older bees do the honey-gathering. The queen-larva grows rapidly, and in five days after hatching it becomes full-grown. The mouth of the queen-cell is then sealed over by the bees with wax, and the larva lines the sealing with a layer of silk. A considerable quantity of the royal jelly is left unconsumed in the base of the cell. If the weather is fine, as soon as

\*See "The Honey Bee," by T. W. Cowan, second edition, pp. 120 to 124.

some of the queen-cells are sealed, the first swarm, consisting of the parent queen, accompanied by a large number of young bees, leaves the hive. The larva, after a short period of rest, changes to a pupa, which develops into a queen, which, seven days after the sealing of the cell, bites a disc off the tip of the cell and creeps out.

The queens are not all reared at exactly the same time, and several days elapse between the maturing of the first and of the last of them. The first hatched queen destroys those that are immature, unless the colony is strong enough to swarm again, in which case she is prevented by the workers from doing so, and she, and often one or two others, leave the hive

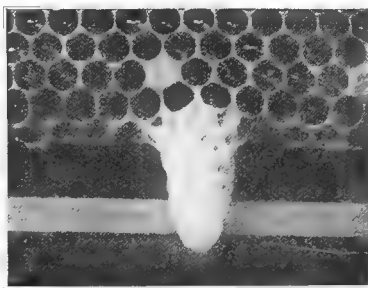

Fig. 2.  
Queen-cell produced under the swarming impulse.

with a second swarm. Third and fourth swarms, accompanied by late hatched queens, may go off a day or two later.

The queens are often forced to remain in their cells by the workers for a day or two after they would naturally hatch, and they are then fed through a hole in the capping just large enough for the passage of the queen's tongue. When a hatched queen meets another, a duel takes place, and the one stings the other to death. Thus, in the end, only one queen remains in each colony or swarm.

If the weather is favourable, this queen makes the first of a series of flights about the fifth day after hatching for the purpose of meeting the drone. The drones are now plentiful, having been reared in large numbers shortly before the swarming season. The period for the queen's flights is between 11.30 a.m. and 2.30 p.m., when the drones are also flying freely. If the weather is favourable, she is fertilised in two or three days, and she usually commences laying about thirty-six hours after fertilisation.

The one impregnation is sufficient for life, and the queen does not again leave the hive unless it is to accompany a

swarm another year. Queen-bees have been known to live as long as five years, but they are often worn out in three.

**Queen-Rearing to Supersede a Failing Queen.**—In the rearing of queens to supersede a queen whose egg-laying powers are failing, fewer queen-cells are started than under the swarming impulse, and they are very lavishly supplied with royal jelly; also the young queens usually emerge, and the surviving one is sometimes fertilised and commences laying before the old one dies. The rearing of some of these queens is sometimes started in the manner described in the following paragraph.

**Queen-Rearing when the Queen is Accidentally Lost.**—Should the queen of a colony die or get lost accidentally, about a dozen larvæ, not more than three days old, which would in the ordinary course develop into workers, are supplied with an abundance of royal jelly, and at the same time their cells are enlarged and formed into queen-cells (Fig. 1, B), with the result that they develop into queens. The explanation of this is that both queen and worker are developed from the female egg, and the worker larva is fed during the first three days of its existence on chyle-food similar to that supplied to the queen larva during the whole term of its existence; but on the fourth day the worker larva is weaned, and a large quantity of honey is added to its food. The nature of the bee is such that this change to a less nourishing diet prevents the development of the reproductive organs, but causes the development of perfect organs for collecting food and for performing the manifold duties of the hive, together with the intelligence necessary to use them; in other words, it makes a worker instead of a queen. Occasionally bees choose larvæ over three days old for rearing into queens; these produce undersized queens which more or less resemble workers.

#### Approximate Duration of Stages in Development of a Fertile Queen-Bee.

Egg	...	...	...	3 days	} 15½ days.
Larva (unsealed)	...	...	5 "		
Sealed queen-cell	...	...	7½ "		
Virgin queen	...	...	6 to 25 "		

### III.—HOW TO SAVE QUEENS REARED UNDER THE SWARMING IMPULSE : A METHOD SUITABLE FOR ALL BEE-KEEPERS.

Bee-keepers who require only a few fertile queens may easily obtain them by saving the queens that are reared naturally under the swarming impulse in their best colonies in the following manner :—

About a week after the first swarm has left the hive the colony is divided into nuclei, each containing one or two of the queen-cells. The best time to do this is when the oldest of the queens is almost ready to emerge. This is generally on the sixth or seventh day after the colony has swarmed, but, if the departure of the swarm has been delayed by unfavourable weather, some of the queens may emerge sooner, and then the operation should be done earlier. The dividing of the colony should not be delayed beyond the seventh day, for, if it is, one or more of the queens is very likely to go off with a swarm, or to destroy her immature sisters. On the other hand, if the operation is carried out much before the sixth day, there is a large amount of brood in the hive, and few bees yet hatched to care for it, so that comparatively few nuclei can, with safety, be made. The work should be carried out about 5 p.m., or, if the day is warm and fine, at 6 p.m., so that no bees can return to the parent hive the same day.

Each nucleus should consist of three combs with the adhering bees, placed in a separate hive and warmly wrapped up, the flight hole being reduced to the size of 2in. by  $\frac{3}{8}$ in. There should be brood and at least one well-formed queen-cell in the central comb, and the other combs should contain plenty of honey. The bees being strongly attracted by the sealed brood and queen-cells, and a large number of them being too young to have taken their first flight, only a few of them will return to the parent hive the next day. There being no eggs or young larvæ in the combs, the brood is not easily chilled. It is, however, important that there should be sufficient bees to keep the queen-cells, and what

brood there is, warm, after all loss of bees has occurred. The nucleus that remains in the parent hive need contain only sufficient bees to cover one or two combs, because of the bees that will return to it from the other nuclei. (See *Forming Nuclei*, page 31.)

Any spare queen-cells may be cut out of the combs and distributed to queenless colonies or nuclei, preferably to those from which a fertile queen has been removed one or two days previously.

Queen-cells and the combs containing them must not be severely jarred or shaken. To find the queen-cells, the bee-keeper should, if necessary, brush the bees from the comb with a feather. In cutting out the queen-cells care must be taken not to damage them. For this purpose, plenty of the surrounding comb should be cut away with them, and those that are joined to one another should not be separated. Very small queen-cells, especially if they are crooked, should be rejected; they are likely to produce undersized queens. Very long and narrow cells are also likely to contain inferior queens; their inordinate length is due to the larva failing to reach at the proper time the stage at which the cell should be sealed, the bees lengthening the unsealed cell. Thick cells of medium length generally contain the best developed queens. The queen can often be seen inside the cell by holding it before a strong light. Before they have time to get chilled, the queen-cells should be inserted, tip downwards, as in nature, between two combs of brood; they should be placed in the warmest part of the brood-nest. They need only be wedged between the combs sufficiently to prevent their dropping down, as the bees will soon fix them securely, but it is always advisable to place each queen-cell in a spiral wire protector (see Fig. 3), which protects its sides from being torn open by hostile bees. The projecting end of the wire is pressed into the middle end of one of the combs in such a way that the queen-cell will hang



Fig. 3.  
Queen-cell Pro-  
tector containing  
Queen-cell.

in the centre of the cluster. A tin cover is slipped through the top of the protector.

Instead of pressing the end of the wire into the comb, I prefer to draw out two or three coils and to attach the end to a cross-piece, as shown in Fig. 4. The cross-piece rests across the top bars of two frames, and the queen-cell hangs from it by the drawn-out wire in the centre of the cluster. The queen-cell is thus easily inserted into, or taken out of, the nucleus without lifting out a frame. The wire itself may be bent to form the cross-piece.



Fig. 4.  
Queen-cell Protector drawn out.

#### IV.—MODERN QUEEN-REARING.

Queens reared under the swarming impulse are, of course, only obtainable from colonies that swarm, and then only during the swarming season, which lasts for about a fortnight in May or June. But, as we have seen, queens are reared from worker larvæ in any colony in which the queen is failing or has been lost. By taking advantage of this fact the queen breeder is enabled to rear queens of any particular strain at any time during the season.

It will have been observed that in the production of a fertile queen there are two distinct stages—(1) the rearing and (2) the fertilisation of the queen. The queen breeder carries on these stages in separate hives. A number of queens are reared in a colony, then they are distributed to nuclei (smaller colonies), one to each nucleus, for fertilisation.

#### V.—REARING THE QUEENS.

It is usually impossible to get queens fertilised before the middle of May, or later than the middle of September. It is, therefore, useless to rear them earlier than May or after the middle of August. Queens are most easily reared and most quickly fertilised in June and July, and the beginner may save himself much trouble and disappointment by confining his operations to these two months.

To rear the queens young worker larvæ of the strain that it is desired to propagate are placed in artificial cups, and are given to a colony from which the queen has been removed, or in which she is failing, or to one in which some of the symptoms of loss or failure of the queen have been artificially produced.

**Preparing the Cups.**—Doolittle appears to have been the first to have made and used artificial cells for the purpose of commercial queen-rearing. His cell-cup is made and fixed in the following manner:—

The tip of a wooden stick (Fig. 5) that has been whittled and sandpapered to the shape and size of the inside of a queen-cell is moistened with water and then dipped into beeswax heated slightly above the melting point, to a depth of about  $\frac{1}{2}$  in., six or seven times. The wax is allowed to solidify between each dip, and each time the stick is dipped a shorter distance. Thus a cup with a thin edge and heavy base is produced. The inside diameter at the mouth of the cup should be barely  $\frac{3}{8}$  in. It is important that the inside surface of the cup should be smooth and round. About a dozen of these cups are fastened by means of drops of melted wax about 1 in. apart on a bar of wood  $\frac{1}{4}$  in. thick and  $\frac{5}{8}$  in. wide. The bar is fixed horizontally in the lower part of a standard frame,

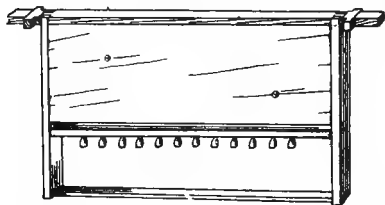

Fig. 6.  
Frame of cups (early style).



Fig. 5.  
Forming  
stick and  
wax cup.

three or four inches from the bottom (Fig. 6). Comb or a block of wood fills the upper part of the frame.

By placing the cups slightly zigzag, a larger number can be fixed on the bar than by placing them in a straight line. The

wax at the point of attachment should be thick, so that when the queen-cells are cut off the bar to be distributed to the nuclei the knife will not enter them.



Wooden cups are now widely used, and they have several advantages over those made of wax. There is no danger of breaking them, and they can be used again and again. They consist of a cylinder of wood, one end of which is hollowed out and lined with beeswax. Various patterns of wooden cups are made and used in America, but they are all too stout for the economical rearing of queens in the cool climate of Britain. Fig. 7 shows the dimensions of a simple form of cup designed by myself in 1902, which fulfils the needed requirements.

This cup is made of a non-resinous and fairly soft wood, such as willow or basswood, and is turned to the dimensions shown. The cups are waxed by pouring beeswax, heated only slightly above the melting point, into them with a spoon; the cup is then immediately turned upside down over the melting pot, and jerked so that the surplus wax drops out. The cup is held a moment longer in the inverted position till the wax in it solidifies. The wax will then be found to have formed a smooth and even layer inside the cup.

For fastening the wooden cup to the bar, a method introduced by G. W. Phillips of fixing a sharp spike or nail-point into the base of the cup, so as to project  $\frac{1}{8}$  in. to  $\frac{1}{4}$  in., is a good one. It is a little difficult for amateurs to fix these spikes satisfactorily into the cups, and I have found that it is easier and more satisfactory to fix them into the bar instead.

In my apiary a special carrier, made as follows, is used, instead of a frame, to carry the queen-cells, because it occupies less room in the hive, an important advantage. Twelve or fourteen fine wire nails,  $\frac{1}{2}$  in. long, are driven  $\frac{7}{8}$  in. apart into a bar  $\frac{1}{4}$  in. thick and  $\frac{1}{2}$  in. wide (Fig. 8), so that the points of the nails project  $\frac{1}{4}$  in. The bar is then nailed to one of the long edges of a board measuring  $\frac{1}{2}$  in. by 4 in. by  $13\frac{3}{4}$  ins. To the opposite edge of this board is nailed a strip  $17$  in. by  $\frac{3}{8}$  in. by  $\frac{1}{2}$  in.; this is the top bar by which the board is suspended in the hive. Small strips  $\frac{1}{8}$  in. thick (pieces of section do very well) are nailed on to either side of the top bar

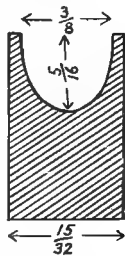

Fig. 7.  
Sladen's Improved Wooden Cup for queen-cells, shown in section.

near the ends to provide the necessary spacing. This carrier may be made from an ordinary division board by sawing a strip 4 in. wide off the lower portion of it.

**Renovating the Cups.**—Cups that have been used are prepared for use again by breaking off the wax out-growth and picking out the more or less dried-up jelly, or the greater part of it, from the inside, with a nail. A wooden stick having its tip rounded to fit the inside of the cup is dipped into a vessel of water, then pressed hard into the cup and twirled, with the result that the inside surface of the cup is rendered perfectly smooth. The water forms

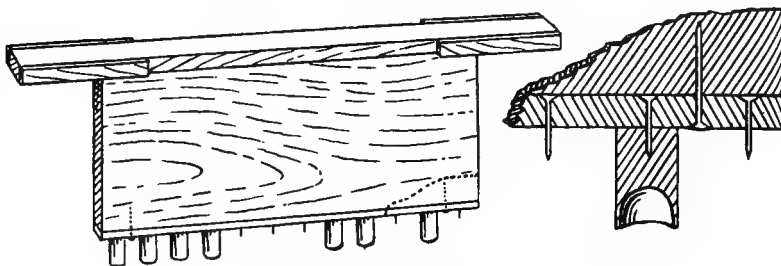

Fig. 8.  
Sladen's carrier for queen-cells.

with the remains of jelly in the cup a milky solution which dries with a glaze which is much appreciated by the bees. To hasten the drying of the cups the excess of water may be shaken out and the cups may be stood out in the sunshine.

**Rearing the Queens in a De-queened Colony.**—An easy and satisfactory way to rear the queens, though not the most economical one, is to employ a de-queened colony and proceed as follows. Other methods will be described later.

Select a prosperous colony containing a fertile queen with the bees covering eight or ten combs, five or more of which contain brood, and in the morning remove the queen and all the combs containing brood, except the two that contain the greatest amount of sealed brood in proportion to the amount of unsealed brood, replacing the combs removed

by others containing honey.\* Leave a space between the two combs of brood for the carrier. About five hours later the colony is ready to receive the larvæ in the cups. If there is no honey flow, it is necessary, for success, that the colony be fed every day, commencing two days before the rearing starts. I find 2lb. of thin sugar syrup (8 pints water to 10lb. sugar), given every evening, to be sufficient.

**Transferring the Larvæ.**—To get the larvæ, we go to the hive containing the queen from which we wish to breed, and looking over the brood combs, we select one that is seen to contain a considerable number of small larvæ of about the right size (see below), preferably one that has not

become dark with repeated use. After having carefully looked for the queen on this comb—if she is there we lift her off into the hive—we give the comb a gentle shake in front of the hive so as to detach the loosely clinging bees, letting them run into the hive, and the rest of the bees we brush off with a twig of spruce.

The comb is now brought indoors, or if the air is still and the temperature is

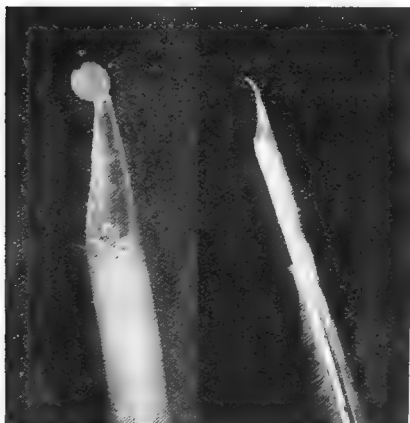

Fig. 9.  
Quill for transferring larvæ.

over 65 degrees the work is done out-of-doors. The comb is placed on a table facing a strong light, and is leaned against a support so as to incline it at such an angle that the light reaches the bottoms of the cells. For transferring the larvæ from their cups, a slender quill is used; one of the stouter wing quills from a domestic fowl

\* It is a good plan to place the surplus combs of brood in a queen-excluded super over a colony in preparation for the formation of the nuclei. (See page 33).

will do very well. The quill is sharpened to a point as broad as that of a "J" pen, but tapering more gradually, the tip to a length of  $\frac{1}{2}$  in. being scraped to make it pliant, and it is turned up as shown in the illustration.

As regards size of larvæ, I find that the best larvæ to take are those that measure about one-half of the side of the hexagon forming the cell, or, expressed in another way, those that are no smaller than a mignonette seed and not quite so large as a lettuce seed. Larvæ that are scarcely larger than the egg are undesirable because the bees often destroy them, probably through failing to notice them, while,

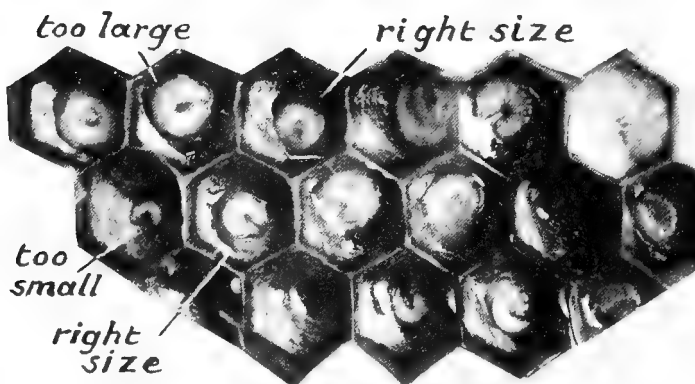

Fig. 10.

Selecting larvæ for queen-rearing. (Magnified about three diameters.)

on the other hand, larvæ that are larger than a lettuce seed produce undersized queens.

If the comb is a new one, a number of larvæ of the right size will probably be found grouped together. The depth of the cells is reduced by shaving their mouths off with a knife. To lift the larva out of its cell the turned-up tip of the quill is brought to the bottom of the cell beside the larva and then scraped sideways over the bottom of the cell under the jelly supporting the larva. When it is brought just sufficiently far under the larva to raise it, the larva is lifted out with as much of the jelly adhering to it as possible and deposited in the centre of the cup.

If one fails to lift a larvæ out on the first attempt it will generally be found difficult to get it up without injuring it, and it is best to leave it and try another.

There is always enough jelly for one to lift and deposit with the larvæ sufficient to form a bed for the latter in the cup, except when the bees are rearing an unusually large amount of brood in proportion to their numbers, and are

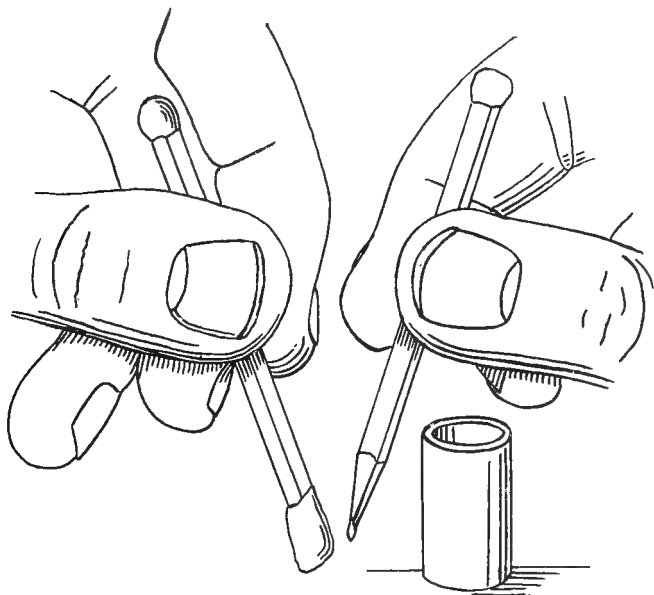

Fig. 11.

Transferring "Royal Jelly" to the Cups on Sharpened Matches.

at the same time very busy in the fields. Then the supply of jelly is so scanty that it is necessary to prime the cups with jelly from an unsealed queen-cell freshly obtained from a hive. Two wooden matches are sharpened to a flat point. One of them is used to thoroughly mix the jelly by stirring it. As much jelly as possible is then brought out on this

match, off which it is picked, in little quantities, on the point of the other match and deposited in the bottoms of the cups. One queen-cell usually contains enough jelly to prime 40 to 60 cups, for only a minute quantity is placed in each cup. A large quantity is worse than useless, for the bees are likely to suck it up and destroy the larva.

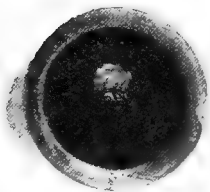

Fig. 12.  
The larva in the Cup.

Sometimes the larvæ of the right size can only be found in a tough old comb and scattered singly among cells containing older brood or pollen. Then some skill is needed to get them out without injuring them. But if one enlarges the mouths of the cells with a pocket knife, and is aided by a good light, practice soon makes even this an easy operation, though not a quick one. It is advisable to give a new comb occasionally and so gradually to work out the old comb.

The larvæ should be given to the bees as soon after they have been placed in the cups as possible, not only because long exposure to the air is liable to chill them—the temperature of the brood nest being about 97 degrees F.—but

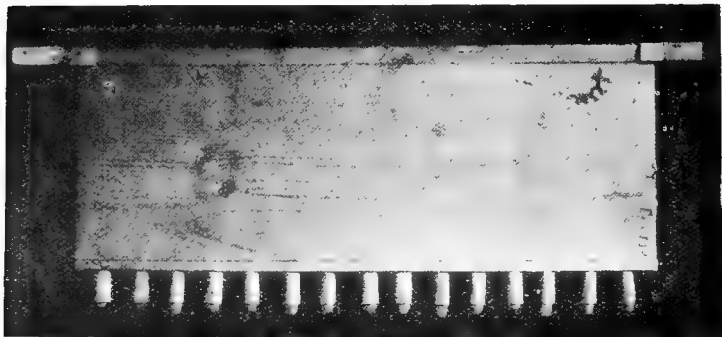

Fig. 13.  
Starting the larvæ.—After 18 hours.

also because it may dry up the jelly. But I have found that on a still day with a temperature of only 65 degrees no harm was done to larvæ that had been exposed for half an hour. Care should be taken not to handle the cups near their mouths with perspiring fingers, nor to puff smoke over them, for the bees are likely to reject them if they detect strange scents in them. It is a good plan to give two carriers carrying altogether 24 to 30 cups to the queen-rearing colony, so as to make allowance for any larvæ that may be destroyed.

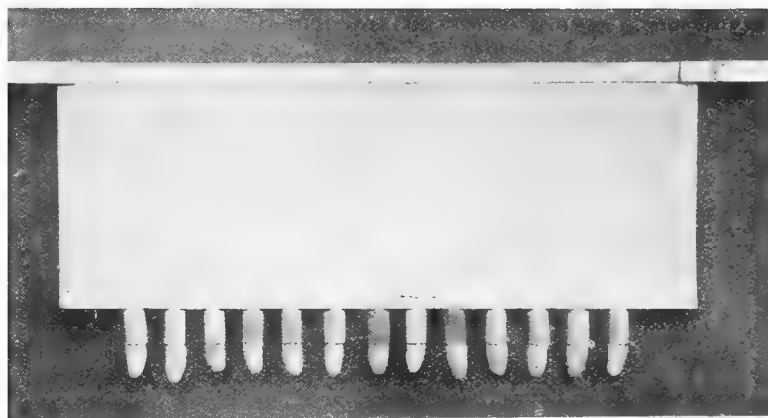

Fig. 14.  
A good batch of sealed queen-cells.

Next morning the cups are examined, and should any be found in which the larvæ have not been bountifully supplied with jelly they are removed, for larvæ that have been starved at the start will develop into undersized and inferior queens.

Although a colony covering eight combs is able to provide as many as two dozen larvæ with sufficient food during the first 24 hours it cannot supply enough food to more than

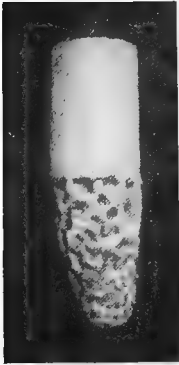

Fig. 15.  
A fine Queen-cell.

about a dozen during the second and third day of feeding, and any above this number must now be removed. They may be given to another colony if one in suitable condition can be found to take them. A colony covering over ten combs may, however, be allowed to rear 20 to 24 queens, provided the two carriers are separated by a comb or two.

The queens will emerge during the tenth or eleventh day after the larvæ were transferred. Consequently, to avoid the risk of a queen getting free and destroying the others, it is necessary to place the cells in separate cages or to distribute them to the nuclei not later than the evening of the ninth day after the larvæ were transferred. How to proceed with this work is explained on pages 6 and 23.

**Rearing Second and Third Batches of Queens in a De-queened Colony.**—As soon as the queen-cells are sealed over, namely, four days after they were started, they may be placed in nursery cages (see page 23) and a second batch of larvæ in cups may be started, any adventitious queen-cells being cut out. Four days later a third batch may be started. But it will generally be found that the bees will reject at the start a larger proportion of larvæ in the second batch than in the first, and a still larger proportion in the third batch, although they will usually rear well those that have been started. This difficulty, if serious, may be overcome by giving them started cells from other colonies. It is not advisable to try to get a de-queened colony to rear a fourth batch of queens, because the bees usually become listless ten or twelve days after their queen has been removed. It now becomes a question what to do with the queenless colony. It may be broken up into a few nuclei, but containing so many old bees it is not well suited for nucleus formation. The best thing to do with it is to give it a fertile queen.



**Combining Queen-Rearing with Artificial Increase.**

—The above method of rearing queens with de-queened bees may be modified so as to combine it with artificial increase, which is sometimes very convenient. For this purpose the colony selected should have at least enough bees to crowd on ten combs. It is moved to a new stand and an empty hive is placed on the old stand. The two combs of sealed brood with the adhering bees and also the bees shaken off two of the other combs of brood, are placed in the new hive, with two or three combs of honey, care being taken to see that the queen remains in the old hive. Two or three hours later the bees in the new hive will be ready to accept larvæ in cups. It is to be noted that although this colony will be reinforced by bees returning from the fields and from the new location, such bees are of hardly any value for queen-rearing, and a colony thus divided should not be allowed to rear more than ten queens. *It is the young bees, many of which will remain with the old queen in the new location, that prepare most of the chyle food, an abundant supply of which is essential for rearing good queens. Consequently, to attempt this method without putting a sufficient number of young bees into the queen-rearing hive will only result in undersized and inferior queens.* A strong colony is also necessary for another reason. Two-thirds of the moved bees are likely to return to the old location. The hive containing the old queen should, therefore, be examined on the evening of each of the first two flying days in order to remove the brood that is not well covered by bees and to place it in other hives where it can be properly cared for.

**Rearing Queens in a Colony that is Superseding its Queen.**—A colony that is superseding its failing queen will accept the larvæ in the cups readily and will supply them with an unusually large amount of jelly. If there is a colony in this condition in the apiary, it should be employed for rearing queens in preference to any other. Queen-cells that already exist on the combs should, of course, be removed; the cups may be primed with the jelly from one of these. If the colony is not strong, combs of hatching brood from other hives should be given to it. Should the old queen linger on the colony can be kept for a long time in condition for rearing successive batches of queens by supplying combs or brood as required.

**Rearing Queens in a Colony Containing an Ordinary Fertile Queen in a Compartment from which the Queen is Excluded.**—Queens may be reared from the larvæ in the cups by a colony containing an ordinary fertile queen by placing them in a portion of the brood-nest from which the queen is excluded by means of the perforated zinc queen-excluder which is commonly used to exclude the queen from the surplus honey chamber.

This is a very good and convenient method, especially when it is desired to rear successive batches, and it is my favourite one.

The queen-rearing compartment may either be in the brood-chamber, or it may be in a super taking brood-combs.

I prefer the brood-chamber, because I find that, worked in the manner that will now be described, it does not require so large a force of bees or so much manipulation.

The brood-chamber should be large enough to take ten or twelve standard frames, one that will take fourteen frames is better still.

To make the queen-excluding partition, an ordinary sheet of queen-excluding zinc is cut into the shape of a division board, with projections at the two top corners, by which it hangs in the hive. It should fit close to the sides and floor. To prevent it from twisting the top and sides may be strengthened with strips of thin wood or metal. The colony chosen for rearing the queens should be a vigorous one, and the bees should be numerous enough to cover at least ten combs.

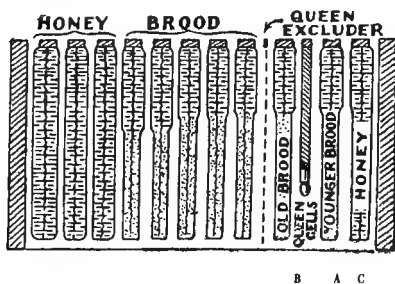

Fig. 16.  
Section of Queen-rearing Hive.

The queen-rearing compartment is prepared the day before the larvæ are given, by selecting two combs containing chiefly sealed and hatching brood from this (or another) hive, and by placing them at one end of the brood-chamber, together with a comb containing honey and pollen,

which is placed between these combs and the wall (Fig. 16). The queen-excluding partition is hung between these combs and the rest of the combs in the hive. To make sure that the queen is not in the queen-rearing compartment, either she must be found, or each comb that is placed in the queen-rearing compartment must previously have all the bees shaken off it into the other part of the hive. The comb of brood which is next the queen-excluder should be the one that contains the most hatching brood. The cups are hung between the two frames of brood.

When rearing successive batches (which can be done every four days by caging the sealed cells, or every three days if the cells are started by other bees), in order to maintain a sufficient amount of brood in the queen-rearing compartment, it will be necessary, at intervals of about eight to ten days, to place in it a comb containing brood from the compartment containing the queen, or, if the colony requires strengthening, from another hive. This comb of brood should be placed at A, Fig. 16, between the queen-cells and the outside comb of honey; the previously-given comb of brood, which now contains only old brood, is then placed at B, between the queen-cells and the compartment containing the queen, and the comb of brood that occupied this position takes the place (C) of the outside comb, which is removed. Thus each comb of brood that is given occupies successively the positions A, B, and C, and is then removed.\*

The colony should be fed every evening unless a decided honey flow is in progress.

Rearing queens in the super is advantageous in the case of very strong colonies that are already working well in the super. All the brood combs, except three or four, may be placed in the super, and if there is a good honey-flow going on their places may be occupied with frames of foundation. This treatment is often effective in preventing swarming, and the brood combs in the super, with the adhering bees, will be in just the right condition for forming excellent nuclei (see

---

\* It is well to remember that it is possible for queens to be reared from the larvæ in the combs that are placed in the queen-rearing compartment, and that should any such queen hatch it will destroy the cells. I used to search regularly for queen-cells on these combs, but having found only one in the course of many years, I have discontinued the practice.

page 33) nine or ten days later, when the queen-cells are ripe and ready for distribution. It is useless to place brood in the super and to try to rear queens there unless the bees are already working in the super, for, if they are not strong enough to do this, much young brood will be destroyed, and few or no queens will be produced.

The bees in the queen-rearing compartment of a hive containing a fertile queen will sometimes destroy or neglect many of the larvæ when given to them in the cups, although they will accept them readily and attend to them well after they have been started. In such cases the larvæ in the cups must first be given to bees that are in a better condition for accepting them, and then when started by these bees they can be given to the queen-rearing colony.

**Methods of Starting the Queen-Cells.**—The best methods of getting the larvæ in the cups accepted may be enumerated as follows:—

(1) *By placing them in a colony that is superseding its failing queen.*

(2) *By giving them to a colony that has been deprived of its fertile queen and most of its brood in one operation from three to twenty-four hours previously, as explained on page 10.*

(3) *By giving them to strong nuclei from which the fertile queen has been removed one, two, or three days previously.* This, although in average cases less effective than method No. 2, has been my favourite method, because in my system of testing queens I have usually had many such nuclei.

(4) *By giving them to bees that have been deprived of their fertile queen and all their brood in one operation, and have then been confined in a box for four or five hours.* Prepare a box (Fig. 17), made to take three combs, covering it with wire-cloth on the underside so as to provide plenty of ventilation, yet not much light, and fitting it with a removable lid *b* containing a slot large enough for the insertion of two carriers and capable of being closed with the strip *d*.

Go to a strong colony about noon, when the bees are flying freely, and after having found the comb carrying the queen and laid it on one side, shake the bees off four or five of the brood combs into the box. Immediately after this

place two combs containing unsealed honey in the box and then cover the box quickly before many bees can escape. A funnel may be found useful for shaking the bees into the box. Place the box in a cool place, and four hours later insert the larvæ in the cups.

It is best to shake the bees off the combs when many are out gathering honey, as then the bees taken will be chiefly young nurse bees. These start the cells better than the older field bees, and they are less restless in confinement. The

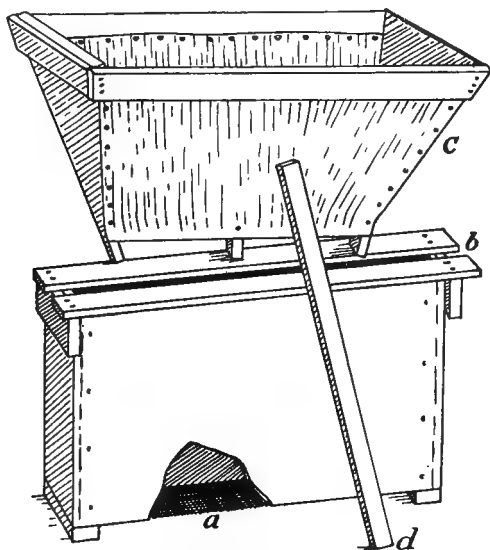

Fig. 17.

Box for confining bees without brood or queen, *a*, portion of side removed to show wire-cloth bottom, *b*, lid, *c*, funnel, *d*, strip of wood to close slot in lid.

inclusion of a few drones with the confined bees does not affect the results. Formerly I employed this method extensively, but finding less laborious methods sufficiently satisfactory I have almost given it up.

Whichever method of starting the cells is employed, the cups should be left with the starting colony over night, and

then, when they are placed in the rearing colony, the imperfectly started ones may be weeded out.

Some colonies accept the larvæ and rear the queens more readily and better than others. Races also show a marked difference in this respect. English black bees and hybrids generally accept larvæ more readily and pay more attention to them than pure Italians.

**Other Methods of Rearing Queens in a Colony Containing a Fertile Queen.**—Several other methods are mentioned by American writers. One of these is to cage the queen in the hive from a few hours before the queen-cells are started until they are sealed, when they in turn are caged.

Another method is to place the queen-cells, as soon as they are started, in a small cage made of queen-excluding zinc. I do not consider this to be a good method, because in testing it in my apiary I find that the queens are smaller, and take rather longer in developing than those reared by the methods already given. This is probably due to the queen-excluding zinc preventing the bees from attending to the queen-cells and larvæ sufficiently.

**Recording Notes.**—The date the batch is started, the name of the queen bred from—I use letters of the alphabet to denote my breeding queens—and the numbers of the hives to which the larvæ are given should be noted in a pocket-book at the time. Should any cups be placed in new hives as the result of the examination made on the next morning, the additional facts are duly noted in the book.

Also, on the fourth day, or later, the cells are caged and placed in a new colony to incubate, a note is made of the number of the hive into which they have been moved. When the cells are distributed to the nuclei this number is crossed out. By consulting the book occasionally one need not be afraid that one will leave a batch too long in a hive, and one knows where to find it at once. Also, a record is preserved of the parentage of all the queens bred.

My system of numbering my hives may be worth mentioning, because it prevents serious confusion being caused by moving the hives about the apiary. It is really the stands, and not the hives, that are numbered. The apiary contains five rows of permanent stands, each consisting of four bricks

on which the hives are placed.\* The stands in the back row commencing from the left are numbered 101, 102, 103, 104, and so on. The stands in the second row are numbered 201, 202, 203, 204, and so on. Similarly those in the third row commence at 301; those in the fourth at 401, and those in the fifth at 501. In an apiary where the numbers of stands in each row does not exceed nine, the numbering of the rows may begin at 11, 21, 31, 51, etc. Should a hive in which rearing or incubating is going on be moved to a new stand its number is altered in the recent entries in the book.

STARTED	PARENTAGE	STARTED AND REARED IN	INCUBATED IN
July 15	C	407, <del>110</del> <del>213</del> 105	<del>302</del>  109
" 19	B	407, 311 105	
" 22	C	<del>304</del> , 102 501	

Fig. 18.

Specimen entries from the Queen-breeder's Note Book.

## VI.—INCUBATING THE QUEEN-CELLS.

A properly-nourished and healthy queen larva has its cell sealed about three and a half days after the larva was transferred to the cup, and from that time until she is ready to emerge, about seven days later, the developing queen requires no other treatment than that the cell containing her should be kept under the conditions of temperature (96deg. to 97deg.)

\* Empty hives are stored under shelter and are not carried out until they are needed. The practice of leaving them amongst the occupied hives was discontinued because it was found that, in the spring especially, they decoyed many bees to their death.

and humidity found in the brood-nest of a normal colony. In fact it is a decided gain to remove the queen-cells as soon as they are sealed and incubate them in cages in such a colony; for as long as they remain uncaged in the queen-rearing colony this cannot well be used for rearing any more queens, and if they are caged there the correct temperature will not be maintained, with the result that the development of the queens is retarded, and they may be affected injuri-

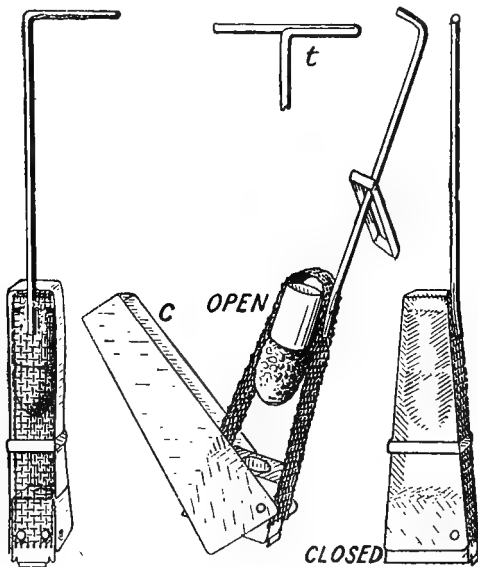

Fig. 19.

Sladen's Combined Incubating and Introducing Cage. The form of top shown at *t* is the best.

ously. Caged queen-cells should always be incubated between combs containing brood in all stages.

Two forms of incubating receptacles have been used in Ripple Court Apiary, the Sladen combined incubating and introducing cage, and the Sladen multiple incubating cage.

The Sladen combined incubating and introducing cage is shown in Fig. 19. It consists of a  $\Omega$ -shaped strip of strong



wire-cloth fastened at the ends to a small block of wood, with a  $\Omega$ -shaped strip of transparent sheet celluloid (*c*) covering both. A stout wire shaft is soldered to the wire-cloth, and is bent at the free end to form a cross piece for hanging the cage between two frames. The celluloid is fixed so that it will swing away in order to permit of the easy insertion or removal of the queen-cell, this being gripped by the wire-cloth. The wire-cloth may be adjusted to clasp queen-cells of any size, not only those built in wooden cups, but also irregularly-shaped ones that may be cut out of the combs. The cells hang about four inches from the top of the comb which is the warmest place. The wooden block has a hole bored through it, and this is filled with soft candy for the queen to eat, should she be allowed to hatch. A tin slide covers the hole underneath, and this is drawn to one side when the cage is used for introducing a queen to a colony. The wooden block is well soaked in hot wax to prevent its absorbing moisture from the candy, and the wire-cloth is coated with varnish to prevent the queens getting poisoned by any salts that may form on the metal. Ten or twelve of these cages can be hung in a row between two combs. They may be placed into or lifted out of the hive one by one without disturbing one another or the frames.

The Sladen multiple incubating cage, which is shown in Fig. 20, is especially useful when large numbers of queens are reared. It consists of a skeleton framework of the size of a standard frame fitted inside with two swinging receptacles made of wire-cloth, containing a number of compartments, separated by partitions of thin wood, each of which is just large enough for the reception of a queen-cell in a cup with sufficient space underneath the cell for the queen to hatch. The cells are prevented from dropping down and filling this space by dents made in the wire-cloth, the partitions being notched to permit the dents to be made deep. In the strip of wood that forms the bases of the compartments are bored little holes to hold soft candy for the queens to feed upon should they be allowed to hatch. This strip is impregnated with paraffin wax to prevent its absorbing moisture from the candy, and a strip of celluloid is nailed on its underside.

The multiple cage is usually kept in one hive throughout the season. The cells are put into it on the fourth day after

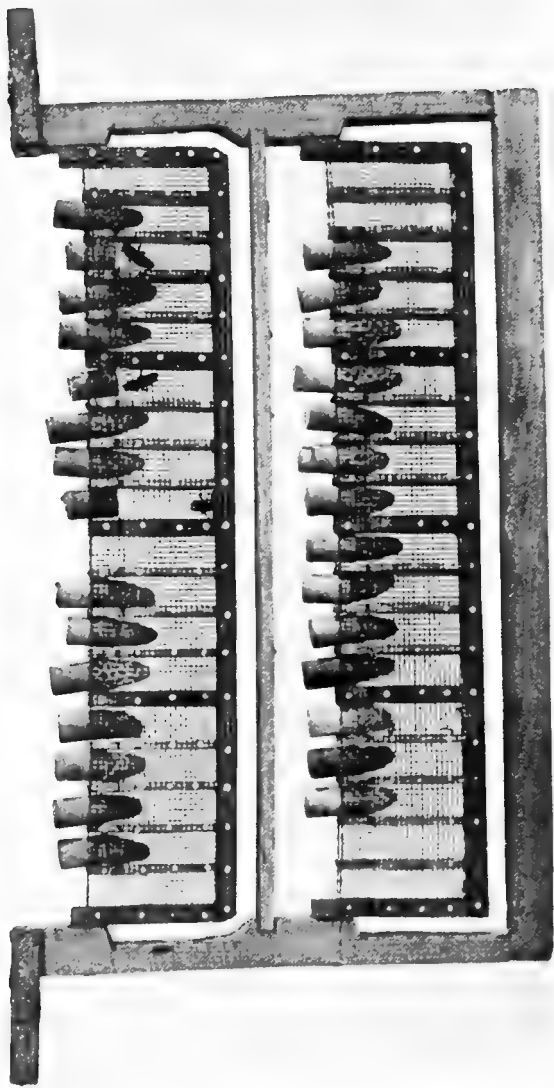

Fig. 20. Sladen's Multiple Incubating Cage.



Fig. 21.  
Size and shape  
of partition in  
Sladen's Multiple  
Cage, showing  
notches.

the larvæ were transferred to the cups, care being taken not to chill or severely jar them. Five days later, viz., on the ninth day after the larvæ were transferred, the cells are distributed to the nuclei, unless virgin queens are wanted. In this case, the little compartments are provisioned with candy, a little ball of soft candy being dropped into the hole at the bottom of each compartment and pressed out flat with the end of a pencil. Of course, the cell has to be temporarily removed to permit of this being done. It is unwise to provision the nursery much before the ninth day, because then the candy is apt to dry up before the queens emerge. The nursery is examined again on the evening of the tenth day after the larvæ were transferred, and if any queens have emerged their cells are turned upside down (see Fig. 20). The same thing is done on the morning of the eleventh day, and if all the queens have not hatched by then, it is done again on the evening of the eleventh day. This

reversing of the cells within about twelve hours of the hatching of the queen is rather important, for, if it is not done a considerable percentage of the queens are likely to die as the result of their creeping again into their cells and being unable to back out. Often, too, they get their antennæ stuck in the viscid jelly in the base of the cell, and sometimes a queen will jam herself between the cell and the wall of the cage. Queens are liable to die if allowed to remain long in the cages, so they should be removed as soon as they are ready. In warm weather a queen is fit to travel twenty-four hours, and in cool weather forty-eight hours after she has hatched. The best age for introducing a queen to a nucleus specially formed to receive her is from one and a half to three days after hatching. It is sometimes a good plan to put a worker or two with the queen as soon as it is seen that she has hatched, but it is a curious fact that these workers very often die, though the queen remains alive.

One of the chief advantages of the cages above described is that they permit of the incubating of a large number of

queens in a very small space, thus conserving heat. Their thickness scarcely exceeds half an inch, and there is no superfluous space in them.

## VII.—NUCLEI AND FERTILISATION OF QUEENS.

A nucleus is a diminutive colony, the use of which to the queen-breeder is to provide a home for the queen, from which she may fly and get fertilised.

**Nucleus Hives.**— Each nucleus may be placed in a separate hive of the ordinary pattern. But if many nuclei are wanted it is more satisfactory to use a special nucleus

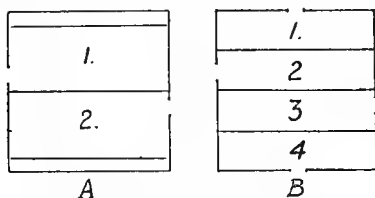

Fig. 22.

Arrangement of Nuclei in Hives, showing best positions for Entrances.

hive made to take two or three nuclei, for then the nuclei help to keep one another warm, occupy less space, cost less to house, and can be more quickly examined and fed. It is, however, important that the entrances should

be some distance from one another to avoid the risk of a returning queen entering another nucleus in mistake for her own.

Fig. 23 shows a pattern of nucleus hive that has been employed in Ripple Court Apiary for some years with most successful results. The hive takes three nuclei, each supplied with three combs. It consists of an ordinary ten-frame brood-chamber divided into three compartments by means of two close-fitting division-boards. The entrances are 2in. long and  $\frac{3}{8}$ in. deep, and are situated as far as possible from one another, being arranged as shown in Fig. 24. The floor consists of three boards nailed on to two strong joists. No plinths are necessary on the lower edges of the brood-chamber. The roof is flat-topped with the sides descending about 2in.; it is covered with zinc or waterproof paper. Brood-chamber and roof are painted

white. The hive is supported on bricks, a brick being placed under each entrance for the bees to alight upon.

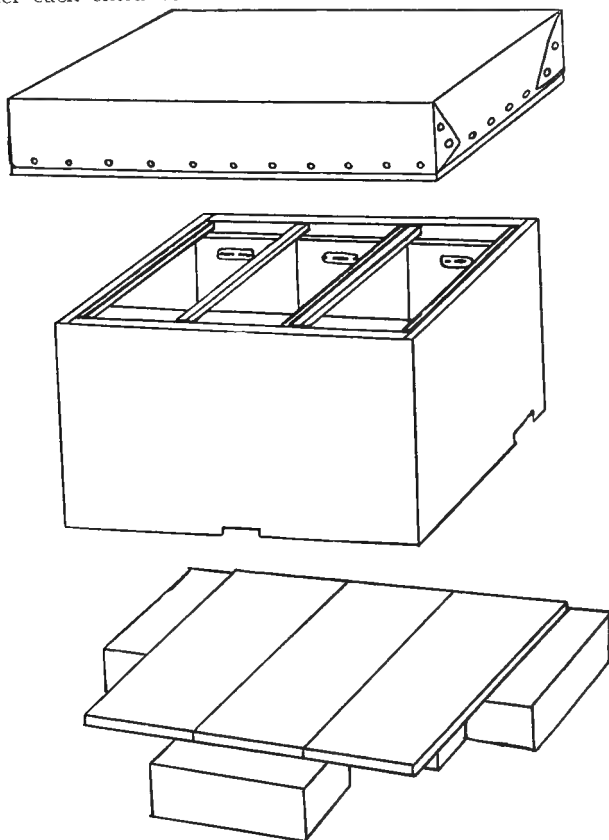

Fig. 23.  
Sladen's Nucleus Hive for three Nuclei.

To facilitate examination the quilt is cut into two pieces, one of them measuring 5in. by 18in. to cover one of the side nuclei, and the other 10in. by 18in. to cover the other two. The brood-chamber measures

15½ in. across, which provides just sufficient room for the nine frames spaced with W. B. C. metal ends, with the two division boards, each ¾ in. thick, and three strips, each 17 in. by ¾ in. by ¼ in., one of which is placed next the division board in each nucleus. These strips are lifted out before manipulation, and so provide room to work.

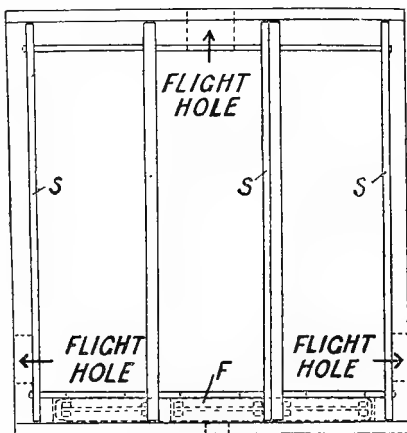

Fig. 24.  
Plan of Sladen's Nucleus Hive.  
s.s.s., Strips. *f*, Feeder in Wall.

A feeder is placed inside the double wall at the back of the brood-chamber. This consists of a deep tin vessel divided into three compartments by wooden strips *b, b*. The feeder is filled

through a hole in the back of the hive by means of a funnel, and the syrup flows into compartments through wire-cloth nailed on to the bottoms of the wooden divisions. The

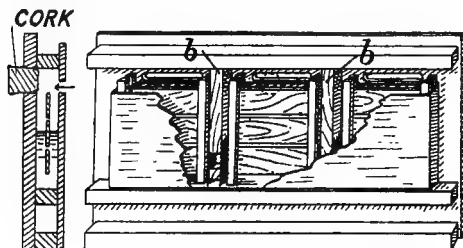

Fig. 25  
Tin Feeder in Sladen's Nucleus Hive.

hole is closed with a cork. Each nucleus communicates with the compartment in the feeder opposite to it through an opening in the inner wall

of the brood-chamber near the top, covered with queen-excluding zinc. A wooden fence made of thin slats nailed to cleats is placed in each feeder for the bees to crawl upon when they

got in to take the syrup. The advantage of this feeder is that the three nuclei are fed at one filling without the necessity of opening the hive.

**Forming Nuclei.**—In forming nuclei it should be borne in mind that *young bees are better than old ones*, both because the young ones are less likely to return to the parent hive, and also because they will live longer. Also, *unsealed brood is undesirable*; it is likely to get chilled and to die, it prevents the bees accepting a virgin, and also it provides the means for rearing another queen, which is sure to be an inferior, indeed a practically worthless one. But brood that is all sealed is desirable, for it strengthens the bees' sense of home and it adds young bees to the population after the nucleus is established, such bees being very valuable should the fertilisation of the queen be long delayed by bad weather. Satisfactory nuclei may, however, be made without any brood at all, but this is only advised when the conditions indicate the probability of early fertilisation.

The nuclei may be supplied either with ripe queen-cells, that is to say, cells from which the queens are shortly due to hatch, or with queens that have already hatched. By introducing hatched queens the queens are old enough to be mated six or less days after the nucleus was formed, whereas if cells are given they are not old enough until at least eight days after formation; also, as the queens are seen before they are given to the nuclei the most desirable looking ones may be selected and the inferior ones rejected. Hatched queens are, however, likely to be killed when introduced to established nuclei, but for newly formed nuclei they are better than queen-cells, because they can be introduced safely, and they form a stronger incentive than queen-cells for the bees of the nucleus to stop in their hive. The return of bees from newly-formed nuclei is indeed one of the difficulties that the queen-breeder has to contend against.

If one has two apiaries situate two miles or more apart, the return of the bees may be entirely avoided by making up the nuclei from colonies in the one apiary and putting them out in the other. The same result may be accomplished if one can establish a mating station two or more miles away from one's apiary.

But often a bee-keeper is compelled to place his nuclei within a few yards of the hives from which the bees are obtained.

One way of preventing many bees from returning is to keep them confined for five days, but this method cannot be recommended unless they can be placed in a cool and dark cellar, for in their efforts to get out they rush about and gorge themselves with food, and, being unable to evacuate the accumulated waste matter, they die, the mortality being specially great amongst the old bees.

It is, however, possible to get bees to remain in the new hive without confining them for any length of time. It has been done in my apiary more or less successfully on many occasions.

The bees are taken from their hive without any queen or any unsealed brood, and confined in a limited space from about 1 p.m. until nightfall, due precautions for the supply of food and air being taken. About four hours after the confinement commenced a virgin two or three days old is run in amongst the excited bees, who accept her immediately. The nucleus is not disturbed for a day or two, and usually very few bees return.

In carrying out this method in the case of nuclei placed in Sladen nucleus hives, each nucleus is made to consist of sufficient bees to cover three combs thinly, or two combs thickly, and it is placed, with three combs, in its compartment occupying one-third of the space in the hive. The combs together contain at least 3lbs. of honey, or syrup—5lbs. is better—and one or two of them, though this is not essential, should contain some sealed brood. Care is taken to see that no eggs, larva, queen-cells, or queens, are included.

While it is possible to succeed in making up such nuclei with bees taken from any hives that can spare them it is much better to select bees that are in the most suitable condition.

The best are obtained by breaking up colonies that have swarmed or have had their queens removed ten or fifteen days previously (all queen-cells having been removed before they could hatch). Advantages derived from making the nuclei from such colonies are that they supply the combs of honey and sealed brood that are wanted, and also that the bees have



grown somewhat idle and forgetful of their old location, and, therefore do not readily return to it.

Unfortunately, colonies in these conditions are not often available, but almost as good results may be got by using combs of brood that have been placed in queen-excluded supers ten to fifteen days before the nuclei are formed, with the adhering bees.\*† In a well-stocked queen-rearing apiary, this is, indeed, the way in which the majority of the nuclei should be formed. It is a good plan to follow for discouraging swarming, two or three combs of brood being taken out of the brood chamber and empty combs supplied in their place.

When nuclei are wanted and no previous provision has been made for forming them, they may be made by shaking the bees off three or four of the brood combs of an ordinary colony, and supplying them with combs of honey, care being taken to see that the queen is not included. It is not wise to mix bees from different hives unless honey drops out of the combs, for if there is no honey flow they may fight and kill one another in large numbers.

As soon as the bees and combs have been placed in the hive a quilt is put on top and the entrance is stuffed with grass to prevent the bees from escaping. The two remaining compartments of the hive are then stocked in the same way. The quilts covering the frames are of thin sacking, obtained by cutting up old American flour bags, and with the grass in the entrance they supply the requisite ventilation. The quilts are held down with a rack—an ordinary section rack does very well. Special care is taken to prevent the confined bees from getting overheated and thus stifled, the hive being shaded from sunshine and, if the temperature is above 70 degrees, or there is no wind, fewer bees are placed in it. If the quilts get thoroughly wet over the spaces between the frames—a little moisture does not matter—it is a sign that the bees are getting overheated and some should be let out.

About 5 p.m. the hive is rapped so as to cause a great humming and the emission of the alluring scent (see page

---

\* The queens may be reared in these supers. See page 19.

† There should be plenty of bees in the super when the brood is put in, or much of the young brood will be destroyed.

73), and then a virgin 36 hours to three days old is run into each nucleus through a hole made in the quilt with the point of a pencil. At the same time a note is made of the parentage and date of hatching of each queen on a card tacked on the inside of the roof. At dusk the grass is removed from the entrances and the rack removed from over the frames, the roof being placed there instead. The reaction of contentment that follows the introduction of the queen after four hours of intense excitement usually lasts through the following day, provided the bees are left perfectly quiet. It is true a few bees fly out in quest of honey, carefully marking the new location, but they never return, and the non-arrival of food-laden bees has a quieting effect on those that remain. Sometimes, however, they get excited and begin flying out in some numbers. This rapid diminution in the population generally causes a panic and stampede, and the bees—even the young ones that have never flown before—desert the hive in a wholesale manner. To guard against such an accident it is best to watch the newly-formed nuclei carefully on the first morning, and if too many bees are seen to be leaving any of them, to immediately re-block its entrance with grass. It is very likely to happen if the queen is less than 36 hours old when introduced, such a queen being often unnoticed. Another cause of the trouble is placing

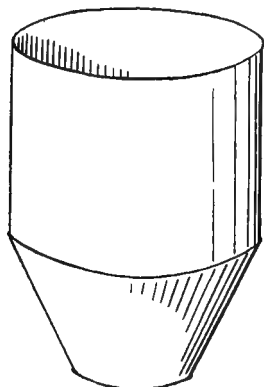

Fig. 26.  
Funnel for shaking bees into a hive.

insufficient bees in the nucleus to fairly crowd it during confinement, for, in this case, the bees are likely to kill the queen when she is introduced, especially if they have been obtained from a hive containing a fertile queen. During the first few days of its existence, the only time of the day when a nucleus should be examined is in the evening. If, on the first evening, any nucleus is found to have lost two-thirds or more of its original strength during the day or to have insufficient bees to cover its brood, it must be reinforced by young

bees shaken into it off a brood comb from another colony. For this purpose it is convenient to use a large funnel.\*

Some nuclei lose hardly any bees. This is frequently the case with nuclei made up from colonies that have been queenless for one or two weeks. With most nuclei, however, there is more or less loss, and if half the bees remain it may be considered fairly good.

After three or four days the initial dwindling ceases, and if the nucleus was supplied with a good deal of sealed brood when it was made up, it will have grown quite strong after it has been established about a week. Such a nucleus may now be broken up into two, by removing about two-thirds of the bees to a new hive in the evening. It is best to remove the queen with the bees if she has not yet made a flight, and to give the parent nucleus a ripe queen-cell.

Weak colonies, or those containing chiefly old bees, may generally be made to produce a nucleus by moving the hive to a new location and putting a new hive containing one of the combs covered with bees in the old location to catch the flying bees. A ripe queen-cell is put into the hive at the old location unless there is a flying virgin, in which case the cell must be given to the portion that is moved.

Excellent nuclei may be made from "second" swarms or casts, that is to say, swarms accompanied by virgin queens. Secure the swarm as soon as it has settled and cage the queens to prevent the swarm absconding. An hour before sunset, if the temperature is as low as about 55 degrees, or at sunset if it is about or above 65 degrees, kill the queens and break the swarm up into a number of little swarms, each weighing about half-a-pound, and run into each swarm a two-day-old virgin. The bees will at first miss their comrades and become restless, but the gathering night will make them settle down, and by the morning all desire to unite will have gone. The number of bees in each nucleus may, if necessary, be equalised by exchanging the frames on which the bees are clustering. One advantage possessed by these little swarms is that they do not require combs of honey or

---

\* It is a remarkable fact that bees thus added to a nucleus, even if taken from a different hive, do not attack the virgin. This is probably because they feel themselves to be strangers. Also, they do not attack the bees of the nucleus, which is too weak to set up opposition.

sealed brood, but may be hived on foundation. If this is done, feeding should commence the first evening.

A prime swarm, that is, one accompanied by a fertile queen, cannot be treated in this way. The bees have an intense affection for their old queen, and as soon as they discover that they have lost her they become frenzied and will kill any virgin that may be substituted, though after a while they will accept queen-cells.

**Buying Bees to Make Nuclei.** — Sometimes one has queens ready but no bees for making the nuclei. It is then worth while to buy bees from an apiary situated two or more miles away. If they are shaken off their combs and so caused to rush about and emit the alluring scent, are supplied with plenty of food and are confined pretty closely for four or six hours, they will accept two-day-old virgins even if they have come from colonies containing fertile queens.

**Fertilisation of the Queen.** — On the fifth day after she has emerged, the queen, provided the weather is favourable, takes short flights between the hours of 11 a.m. and 3 p.m., thus accustoming herself to return to the hive and she is followed, at first hesitatingly, but later with more eagerness, by the drones which are then flying in numbers. Her flights are continued on the next day, when they usually culminate in the marriage flight, which lasts about ten or fifteen minutes.

On this occasion, if the drones are plentiful, the queen is closely followed by a crowd of ardent suitors. The excitement brings more drones, probably attracted by scent emitted by the others, and the air grows thick with them. A comet-like flock of drones is formed with the queen in the nucleus, and it darts about in an erratic manner, assuming all kinds of strange shapes. One of the swiftest and strongest of the drones succeeds in seizing the queen and he flies away with her. When the two separate the drone's organs are torn from him and their torn ends usually protrude from the frequently gaping anus of the queen for some hours. The queen is generally rather exhausted after the ordeal and may alight on a leaf of a tree or a blade of grass to rest and recuperate. Should a dark cloud now happen to obscure the sun and a chilly wind spring up she may become benumbed and never

reach home. Having recovered somewhat, she takes wing and flies off to the hive. Here the bees may already be beginning to show signs of alarm at her long absence, working themselves up into a state of excitement, running in and out of the entrance humming and emitting the alluring scent and also taking short flights. The unwonted stir helps to guide the queen to the hive. She hovers about for a few seconds among the excited bees, and then, having assured herself that the hive is her own, she makes a dash for the entrance and, without tarrying, hurries inside.

The first few hours after fertilisation are a critical period in the life of the queen. She is restless and the workers are excited and seem uncertain how to treat her. The remains of the drone organs which hang as an appendage from her tail seem to irritate them, and they follow her and try to catch hold of it. They may even show hostility to the queen herself, and in extreme cases, which occur chiefly in late summer when food is getting scarce and robbers are inclined to be troublesome, they will actually ball her and even sting her. Sometimes the stings prove fatal, but more often they cause paralysis of one or more of the legs. If it is one of the hind legs that is paralysed the queen is useless and should be killed, but if it is one of the middle or fore legs, she will not be any the worse and the paralysed leg will in time wither and drop off. When the queen is being attacked there is generally a good deal of running out and flying about the entrance, and should this be noticed it is best to open the hive and place the queen in a candy introducing cage (see page 47) with the tin slide drawn so that the bees can liberate her in about 24 hours by eating away the candy. Similar symptoms are shown if the queen is lost.

The appendage, if present, dries up and disappears, the abdomen swells, and on the second day after mating provided honey is coming in and it is not too late in the season, the queen begins laying. A queen mated in September may not begin laying for a week or more, or even until the spring, but one can generally coax her to lay by making the colony stronger by uniting and by regular feeding.

For a queen to get mated as early as the sixth or seventh day after emerging from the cell, the temperature must approach or exceed 70 degrees, there must be little or no

wind, and unless it is very warm, the sun must be shining without much intermission. This combination of weather conditions is rare in many parts of Britain, and consequently the majority of queens are not mated until about nine or ten days after emerging, when it seems they venture to take flight in less favourable weather and also are more attractive to the drones. But I have never known a queen to get mated on a day on which the temperature between 11 a.m. and 3 p.m. was less than 62 degrees, and mating has only taken place at this temperature when the air was perfectly still and sunshine bright and continuous.\* When the British Isles are under the influence of depressions advancing from the Atlantic in quick succession, weather sufficiently good for mating may not come for two or three weeks, especially in the north and west and exposed places on the south coast; while on the east coast several days' delay is often caused by a cool anticyclonic breeze from the North Sea.

Abundance of drones and a good honey flow also favour quick mating, but many cases of failure to get mated that are ascribed to lack of drones are really due to insufficiently favourable weather conditions for, when the weather is perfect, drones will discover queens at a great distance from their hives. When, however, drones are scarce, as in April and September, the weather must be very fine indeed to ensure mating.

The workers grow to dislike a queen that flies out day after day without succeeding in getting fertilised, a state of affairs that takes place during a spell of weather that approaches, but does not quite reach, the standard requisite for mating, and they are very likely to pull her about and to tear her already weather-beaten wings, ultimately damaging them to such an extent that she can fly no more, and then they often kill her and turn her out. It is better that the weather, while bad, should be too bad for her to fly. But she cannot wait indefinitely; for, if she fails to get fertilised within a certain period, she will commence to lay eggs which will produce drones only, and she will lay no others during the rest of her life.

---

\* These data are for British Goldenes. Whether British Black queens would be hardier I cannot say.

**Drone-Breeding Queens.**—The age at which a queen is too old to get fertilised has been stated by several authors to be usually twenty-two days, but Berlepsch and Dzierzon are quoted by Cowan ("The Honey-Bee," 2nd Edition, page 141) as having occasionally found a queen to get fertilised at thirty days old, and in one case at forty-seven days. Several of my British Golden queens have failed to get fertilised within three weeks after hatching and have then, the weather improving, met the drone and become properly impregnated.

A British Golden that emerged on July 19, 1912, when killed and examined on August 28, after forty days of continuous bad weather, was found to be unfertilised, but full of eggs, some large enough to be laid.

To make a *post mortem* examination of a queen for the purpose of ascertaining whether she has been fertilised or not requires no technical skill nor special instruments. Carefully tear apart the abdomen near the tip with the thumb-nail, then squeeze or drag out of the severed portion on to the finger the internal organs, taking care not to crush them. Amongst them will be found a firm globular body about 1-24-in. in diameter, and of a silvery colour. This is the spermatheca, or vessel for containing the millions of spermatazoa supplied by the drone. The silveriness is due to a network of tracheæ which can easily be rubbed off, leaving the spermatheca, which, if the queen is unfertilised, is filled with a perfectly clear fluid and is as transparent as a drop of water; but, if the queen has been fertilised, is cloudy, being filled with countless spermatazoa, which, under the microscope, are seen to be in motion, reminding one of a field of barley in the ear waving in a breeze.

In a considerable number of drone-breeding queens that I have killed and examined it was found that the spermatheca contained spermatazoa, but it was often less densely packed with them than in a normal fertile queen. Such queens may produce drones only or, more often, a mixture of drones and workers. The recovery of queens producing a mixture has been reported, but I have never kept one long enough to confirm this. It is evident that when the spermatazoa are very deficient in numbers, recovery will not be permanent. The only way to tell for certain whether a queen

is a drone-breeder or not is to wait until the brood is sealed over. If the sealing of the cells is flat they contain worker brood, but if it is convex they contain drone brood.

Drone brood in worker cells is also produced by fertile workers in the absence of a queen. When the eggs are laid irregularly, three or more being placed in some cells and none in others, it may be suspected that a fertile worker is present. With some foreign races of bees—Cyprians, for instance—workers will in time become fertile in all hives lacking a fertile queen; but in hives of English or Italian bees fertile workers are rare.

**Management of Nuclei.**—Nuclei require regular attention. They must not be allowed to run short of food, feeding being resorted to when necessary, and continued, if need be, twice a week. During a dearth of honey feeding is valuable for stimulating the queen and drones to fly.

If the queen has got lost or injured, or has become a drone-breeder, a ripe queen-cell must be given in her place as soon as possible. A frame of sealed brood from a nucleus that can spare it should be given to keep up the population. About half-an-hour after a queen gets lost the bees become more or less excited and restless. They start humming, and a few will run or fly out of the entrance and back again. The same symptoms are shown when the queen is balled, and also occasionally, when nothing is wrong. If the hive is rapped or examined the humming develops into a roar. For several days after the queen is lost this roaring may be induced by rapping or examining. A nucleus that does not roar in the least when examined is sure to contain a queen or occupied queen-cells.

When the honey flow begins to decline special precautions have to be taken to guard against robbing. These consist in:—

(1) Keeping the entrances of the nuclei small—pieces of section may be tacked over them to reduce their size to  $\frac{3}{8}$  in. by  $\frac{3}{8}$  in.

(2) Maintaining in each nucleus a sufficient population of bees between the ages of one and three weeks. This is best done by the supply of sealed brood in good time. Very young bees are powerless against robbers and old bees are little better.



(3) Opening the hive as a rule only in the evening during the hour or two preceding sunset. Robbers quickly learn to follow the smoker and will pounce down on a nucleus directly it is opened, and having once gained an entrance, other bees from the robbing hive or hives will soon join them, but darkness puts a stop to their depredations.

Feeding is best done at dusk. In America soft candy is sometimes used instead of syrup, because it causes less excitement. Fresh nuclei should not be formed when the honey-flow is declining or over. Prospectors are sure to be prowling about then, and they are wonderfully quick in discovering a newly-formed nucleus, which, having no spirit to resist, will be completely overcome in two or three hours by the host of robbers which in a trice follow on the heels of the innocent-looking discoverers. Of course, no honey or syrup should be dropped about the apiary, and the door of the honey-house should be kept strictly closed at all times. A solar wax extractor is not desirable in a queen-rearing apiary: the smell of the wax arouses the robbing instinct. Robbers make robbers, and it is much better and easier to prevent the vice beginning than to try to cure it.

The nuclei should be examined at least every tenth day. Examinations should not take place in windy weather, for this may induce balling, and consequently the maiming or killing of queens. The combs, when being examined, should be held over the open hive, so that, if the queen drops off, she will not be lost. A card for notes should be tacked on the underside of the roof of each nucleus hive. On this should be written with an ordinary lead pencil at the time the queen or queen-cell was given, her parentage and the date of emergence, and subsequently every event of importance—for instance, the estimated date at which laying commenced and, if the queen is kept long enough, the colour of the workers she produces, and finally the date she is removed, this being followed by a line drawn across the card.

The queen should not be removed until most of her eggs have hatched, or many of these will perhaps be destroyed. If she can be left in the hive a few days longer, all the better. When she is taken away, a ripe queen-cell, from which the new queen is due to emerge

within a day or two, is given to the nucleus in the queen-cell protector, shown in Fig. 4 and described on page 7, the date she is due to emerge and her parentage being noted on the card. I do not find it satisfactory to introduce hatched virgins to established nuclei. too many are killed.

A convenient way to mark hives that want attention is to place stones on them. In Ripple Court Apiary one stone signifies that the hive should be examined again in two or three days, while two stones indicates queenlessness.

At the end of the season the three nuclei in each hive are united to form one strong colony. I have, however, found no difficulty in wintering a nucleus on three full-sized combs in the mild climate of Dover, provided it is strong and the combs are full of stores. But only two nuclei should be wintered under one roof, for they keep one another warm better than three.

When uniting nuclei at the end of the season it is very important in the case of hybrids at least to see that the combs are fairly full of stores. If they are not, the queen is very likely to be killed. This catastrophe can, however, be prevented by caging her for three days and feeding the colony heavily. I always cage the queen when uniting, not liberating her for three days, and then the uniting can be done as soon as the surplus queens are removed.

**Baby Nuclei.**—Of late years diminutive nuclei on combs less than full size have come into vogue, and if a few simple details in their management are understood and followed, it is possible to get a larger number of queens fertilised in an apiary of given strength and comb area by the use of such nuclei than by the use of nuclei on full-sized combs. It is true that small nuclei can be also kept on full-sized combs, but with miniature hives and frames the cluster is somewhat more compact. As the baby hives are quite small they are very handy for transportation to out apiaries, and especially to isolated mating stations in making attempts to get queens mated by special drones. Indeed, properly packed to prevent the escape of bees, they may even be sent by parcel post.

The chief disadvantage of these baby nuclei is that only a small quantity of brood can be reared in them, and, therefore, they are almost useless for building up into

colonies. Almost every queen-breeder wants bees as well as queens. Then the various disadvantages of having two sizes of frame must also be taken into account. But when there is a pressing demand for queens, a few baby nuclei will prove profitable.

The best size of frames for baby nuclei is half size, so that two combs together will make a full-sized comb. The two half frames fastened together hang like an ordinary standard frame in an ordinary colony, and are there filled with honey and brood. Metal clasps may be used to hold the two half frames together, or they may be hinged together so as to make a folding frame (see Fig. 27), but a folding frame, though convenient, is not so satisfactory as a divisible frame, because it is an advantage to be able to separate the little frames in the nuclei.

Fig. 28 shows a baby nucleus hive that has been used successfully in Ripple Court Apiary for a good many years. It holds two nuclei each on two half frames, with entrances on opposite sides, each measuring  $\frac{1}{2}$  in. by  $\frac{3}{8}$  in. The floor is in one piece with the hive. The nuclei are separated by a close-fitting division board, having spikes

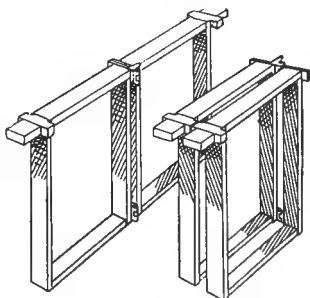

Fig. 27.

Folding Frame for Baby Nuclei.

in the bottom to fix it to the floor, and there is also room on either side for a division board, which does not quite reach the bottom in order to avoid crushing bees during manipulation, together with an extra half inch of space for working. The two nuclei may be united by removal of the central division board. A rack (not shown) is made to hold down the quilt during the confinement of the bees, and a tin feeder, constructed on the same principle as that described on page 36, is encased in the hollow wall supporting the projecting ends of the top bars of the frames.

As many as eight or nine baby nuclei, each on two half frames, may be made from one strong colony. In stocking the hive, sufficient bees should be put in to crowd

on one of the half combs, and it is even more important that the bees should be young, and that there should be plenty of honey and, if possible, sealed brood in the combs than in the case of ordinary nuclei. For the home apiary it would be an advantage to make the baby hive large enough for each nucleus to take an extra half frame if required.

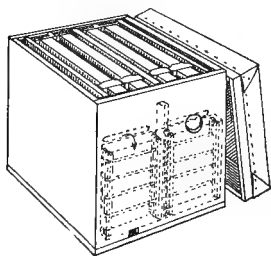

Fig. 28.

Hive for two Baby Nuclei.

A serious disadvantage of baby nuclei occasionally noticed in America is that the bees may leave the hive *en masse* with the queen when she flies out to meet the drone. This, however, has never occurred in my experience in England.

#### VIII.—SENDING QUEENS BY MAIL AND INTRODUCING THEM TO COLONIES.

**Sending Queens by Mail.**—The postal regulations of most countries now allow live bees to be sent by mail, and a great number of queens are distributed in this way every summer. They are sent in small cages, introduced by Benton, containing a special kind of soft candy called “queen candy,” described below. The queen and her attendants will live for several days in one of these cages. Indeed, they will often live for two weeks or more, provided young Italian or hybrid workers of the age at which they are only just distinguishable from adults by their slightly lighter hair, with undistended abdomens, are chosen. If they are not overcrowded, the bees in the cage will stand a temperature up to 90deg., there being always sufficient air for them in the mail bags. Each cage weighs less than two ounces with the candy in it. The queens can therefore be forwarded expeditiously by post to any address at a merely nominal cost.

The cage consists of a block of non-resinous wood—for

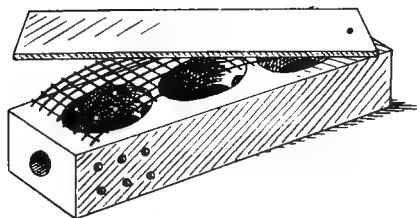

Fig. 29.  
Travelling Cage.

is filled with the queen candy. This hole is lined with wax to prevent the wood absorbing any moisture from the candy. The queen, with her attendants, occupies the two other 1 in. holes, the end one of these having a saw cut, or several little holes, to provide ventilation. A piece of wire-cloth of the kind used in America for screening windows covers the cage, and this is fastened down securely, together with an outer lid or card, by means of a few fine wire nails. It is convenient to insert the queen and her attendants through the end of the  $\frac{3}{8}$  in. hole shown in the figure, each bee being picked up in the fingers by the wings and popped head first into the hole. A small square of tin plate is afterwards tacked over this hole.

In the case of a virgin queen not more than about thirty hours old the workers need not be taken from the same hive as she. But in the case of putting a fertile queen with strange workers, the latter must be caged about four hours beforehand and well fed, and then when the queen is about to be introduced they must be well shaken and made to run about the box until they hum and expose the scent organ. If they continue to do this when the queen is introduced she is safe from attack.

The above travelling cage is perfectly suitable for queens dispatched during summer and autumn, but in March, April and May, when the nights may be cold, and in June also, if the queen is an old one and ovipositing rapidly, she being then in a delicate, easily chilled state, it is better for the queen to be accompanied by about 100 workers in a little box containing a small piece of tough comb filled with sealed

instance, American basswood — measuring 4 in. by  $1\frac{1}{4}$  in. by  $\frac{1}{2}$  in., with three holes of 1 in. diameter bored in it (Fig. 29). The holes are connected by a hole of  $\frac{3}{8}$  in. diameter, bored through them. The 1 in. hole at one end

honey, fastened in a little frame by means of waxed string.

**Queen Candy.**—This useful article is made by kneading finely powdered white cane sugar with warm honey to the consistency of putty. It takes the sugar some days to absorb the honey, so a little fresh sugar should be kneaded in on several successive days. The peculiar property of this candy is that it will retain its moisture for a long time, and yet it is too firm to fall out of shape at ordinary temperatures.

**Introducing Fertile Queens.**—A colony is in the most favourable condition for accepting a strange fertile queen when it has been deprived of its own queen from one to three days previously. Although the queen will sometimes be accepted if she is simply dropped among the bees it is always advisable to employ some method of introducing her that will reduce the risk. The method that is on the whole the most satisfactory and is most extensively employed is to keep the queen in a cage, in which the workers cannot molest her, until she has acquired the scent of the hive, and they have become accustomed to her. Food must, of course, be provided for the queen in the cage. The new queen may be caged in the hive at the same time that the old one is taken out.

**Introducing Cage for Pressing into the Comb.**—This simple and efficient cage (Fig. 30) may be made from a piece of stiff wire cloth (with about twelve wires to the inch)  $2\frac{1}{4}$  in. square, by cutting  $\frac{5}{8}$  in. squares out of each corner, and by bending down the sides so formed. The queen is placed in the cage by herself or with one or two freshly-hatched workers, and the cage is pressed into one of the middle combs so that one or two cells containing unsealed honey are enclosed in the cage. The cage will sink better

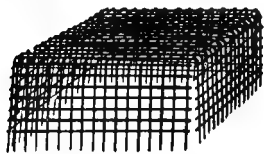

Fig. 30.  
Introducing-cage for Pressing  
into the Comb.

into the comb if two or three strands of the wire are pulled off the edges. In spring a caging of 24 to 36 hours is generally long enough, but in the autumn double that time is often necessary. If, when the hive is opened to remove the cage, the bees are seen to be clustering closely around the cage,

the queen should be left in it longer. After the queen has been liberated the bees should not be disturbed for four or five days.

**Candy Introducing Cage** (Fig. 31).—With this cage (called in America the “Miller” cage) the queen is liberated

by the bees eating through a plug of queen candy on which the queen feeds. The time taken by the bees in eating through this plug is usually about eighteen hours, but it may be lengthened by tacking a slip of pasteboard over the candy. The bees are made aware of the presence of the candy by a pinhole pricked in the pasteboard.

The commencement of the liberation of the queen may be

delayed for any length of time by keeping a strip of tin over the candy. The queen is inserted in the cage by the removal of the wooden block *e*. This cage is made thin enough to be slipped between the combs. The tin strip above *e* rests across the top-bars of two frames. A cage on the same principle is illustrated on page 24.

The travelling cage illustrated on page 45 can be used as a candy introducing cage without taking the queen and workers out, but the presence of the workers slightly increases the risk, and it is better to introduce the queen alone in a fresh cage. If it is not known that the apiary from which the queen has come is free from disease, it is always best to introduce the queen in a new cage with fresh candy.

Other methods that have been successfully employed to reduce risk in introduction are exciting the bees by shaking them or smoking them, stupefying them temporarily with tobacco smoke, and smearing the queen with honey.

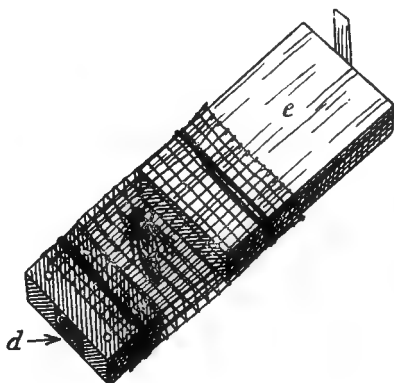

Fig. 31.  
Candy Introducing-cage; *d* Hole for candy; *e* Block which is removed for inserting queen.

A queen should never be introduced to a colony that is short of stores, unless the latter has been fed liberally for several days.

A colony that has been queenless for a long time will not accept a queen so readily as one that has been deprived of its queen or queen-cells only one or two days before. It must be remembered that a colony that has been queenless over ten days will probably have reared a young queen if there were young larvæ in the hive when the old queen was lost. In such a case any queen that might be introduced would certainly be destroyed, unless the young queen was found and removed beforehand. When there is doubt about the presence of a queen in a hive, it is a good plan to give a frame of young brood, and if the bees start forming queen-cells on this it is generally safe to introduce a new queen.

Black bees accept queens more readily than hybrid bees. It is not easy to introduce a black queen to hybrids: even after she has been received she may be attacked and stung, and so killed or paralysed for life.

## IX.—RACES OF BEES.

Of the genus *Apis* three perfectly distinct species are known: *A. dorsata*, *A. florea*, and *A. mellifica*.\* The two first are found in India, Ceylon, and the East Indian Islands,

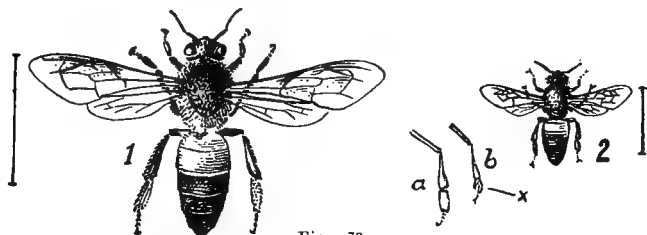

Fig. 32

1. Worker of *Apis dorsata*. 2. Worker of *Apis florea*. a, Posterior leg of drone of *A. mellifica*. b, Ditto of *A. florea*. The lines indicate the actual lengths.

\* *Apis indica*, the bee cultivated in India, is closely allied to *A. mellifica*, and it is doubtful whether it should be regarded as a separate species.



and have not been domesticated. In the winter of 1896-97 I spent a month in India investigating them. *A. dorsata* is larger than our honey-bee, and its comb, which is several feet in length, is suspended, without any covering whatever, from the horizontal limb of a large tree or from an overhanging ledge of rock. Its wax is an article of commerce. *A. florea* is much smaller than our honey-bee, and builds a comb no larger than a man's hand on the branches of shrubs. The drone of *A. florea* has the metatarsus of the hind leg bilobate.

*Apis mellifica* is indigenous to Europe, Asia, and Africa. The following are its most useful varieties:—

**1. The British Black Bee.**—The native bee of the British Isles has the ground colour of the whole body black and has the bands of short white hair on the abdominal segments weak and narrow. In the cool and windy summer climate of the British Isles it is unsurpassed by any other pure race for industry in honey-gathering, working early and late. It also caps its combs beautifully white. It is good tempered if pure, but rather excitable under manipulation, the bees rushing to the corners of the hive like a flock of sheep, but connected with this is the good quality that they are easily detached from their combs by shaking. The queens are not so prolific as those of the other races considered below.

Black bees also occur in France, Germany, and Spain, and a black variety, which the late Mr. W. H. Ashmead, of the U.S. National Museum, told me he believed first came from Spain, has spread over North America. The qualities of all these blacks appear to differ little from those of the British Black bee.

**2. The Italian Bee.**—In Northern Italy and Italian Switzerland there are to be found some very good varieties of bees having the first three segments of the abdomen semi-transparent orange-yellow at the base\* and having broad, pronounced bands of short white hair on each of the segments except the first and the last. The Italian, as these races are called, is very good tempered and quiet under manipulation, clinging tenaciously to its combs, and it defends its

---

\* The yellow on the basal portion of the third segment is often hidden under the overlapping edge of the second segment.

home well from robber bees. Working in temperatures of 75 degrees and over, it is more industrious than the black bee and will travel long distances in search of nectar when flowers are scarce. The queens are more prolific than black queens and the colonies more populous than black colonies. Italians withstand cold winters well; they can also endure great heat in summer and do not die so quickly in confinement as English blacks; but they dwindle in cold springs. Wax moth larvæ do not flourish in their combs. The vast majority of bee-keepers in America, Australia and New Zealand esteem Italians more highly than any other race.

The half-breds produced by Italian queens mated by English black drones are hardy and energetic, and in average seasons in England will yield heavier weights of honey per hive than the blacks, but in damp cold seasons they consume much honey and will starve if not fed. Their temper, too, is rather uncertain, though an experienced bee-keeper can easily manage them.

**3. The Carniolan Bee.**—This is a bee that occurs in Carniola, a small, mountainous province of Austria. The ground colour is entirely black, but the abdominal bands of short white hair are very strongly developed, giving the bee a grey appearance. It is a very good-tempered bee, but in the English climate has been found to be too much given to swarming and to be not such a good honey gatherer as the native bee. In America, however, it has been reported to be a good honey gatherer, but probably most of the reports have been of colonies that were not pure. It caps its comb white. The bees produced by Carniolan queens mated by English black drones are hardy and good honey gatherers.

**4. The Cyprian Bee,** from the Island of Cyprus, is rather smaller than any of the preceding, and has the testaceous bands on the abdominal segments wider. It is quick-tempered. The queens are extremely prolific. The British summer climate is too cold for Cyprians to gather much honey; they also swarm freely. Over a hundred queens are often reared in preparation for swarming. On loss of queen, fertile workers are readily developed. The half-breds produced by Cyprian queens mated by British black drones are industrious and fairly hardy, but very irascible, stinging the operator badly on the least provocation; they continue

to rear brood extensively until quite late in the autumn. Further crossing with blacks is said to produce a very industrious and hardy bee.

**5. The Caucasian Bee** has lately been tried in America, where it has been reported by a few to be the most gentle race of bees known, a good honey producer as a rule, and more prolific than the Italian, but it gathers great quantities of propolis and builds brace combs freely, and the number of its supporters does not seem to be increasing.

**Syrians and Tunisians** are bad propolisers and have other faults.

So far we have considered only the varieties of the honey-bee that occur in nature. But a list of varieties would not be complete without the golden bee, a remarkable breed that has been produced in America by selection for colour from Italians or, some say, a cross between Italians and Cyprians. In this variety the testaceous or golden-yellow colour spreads further over the abdomen than in any European race, giving the bees a striking, and many think, a very handsome appearance. Pure goldens have proved less vigorous than blacks or Italians, and they dwindle badly during long winters and chilly springs. They do not store much honey in the cool summer climate of Britain.

## X.—DRONES AND DRONE-REARING.

During the swarming season, there are in most places sufficient drones for the fertilisation of all queens. The rearing of drones is, however, important, both for fertilising queens by drones of a particular strain, and for getting the queens quickly fertilised before or after the swarming season. After the swarming season, it is possible to get a larger proportion of the queens fertilised by the specially-reared drones than during the swarming season, as these drones can be kept in queenless colonies, or in colonies containing unfertilised queens, for some time after the workers of colonies containing fertile queens have, in accordance with their instinct, turned their own drones out to die.

Dzierson's theory (published about 1845) that the drone is always produced parthenogenetically—*i.e.*, has no father

(although he has a maternal grandfather)—is now generally accepted; this teaches us that it is the characters of the colony that produced the drone's mother that we must expect the drones to transmit. The drone influences his queen and worker progeny very much, and it is of course most desirable that queens of the best strain should be selected for drone-rearing, and also that the drones should be reared under the most favourable conditions. To be of value the drones must be reared in very large numbers and kept in strong colonies.

To rear drones during the natural season (April to June), it is only necessary to place a frame of empty drone comb\* in the centre of the brood-nest of a strong colony. The queen will soon lay drone-eggs in this comb, and the drones reared from these will be flying about a month after the eggs were laid.

Drones are not easily reared late in the season, and in order to have plenty of drones then, the drone-breeding queen should be induced to lay drone-eggs about the end of June or beginning of July, and either she should be removed as soon as her presence is likely to prejudice the rearing or presence of the drones, or the drone-brood, soon after the eggs are hatched, should be given to a queenless colony to be reared; another drone-comb may then be given to the drone-breeding queen. The locality and season will determine the date up to which this work can be continued. If there is no honey-flow, the colonies in which the drone-eggs are laid and in which the drones are reared and kept must be constantly fed. The feeding induces egg-laying, helps to prevent the destruction of drone-brood and drones, and also helps to make the drones fly freely in favourable weather. Virgin queens may be allowed in the colonies containing the drones. To prevent destruction of the drones, these queens, directly they are fertilised, must be removed and other virgins given.

The production of undesirable drones in the queen-rearing apiary may be largely prevented by using full sheets of worker-comb foundation in all hives except those in which it is intended to rear drones. Any drones that may be pro-

---

\* This has larger cells than ordinary worker-comb. Drone-comb foundation can be obtained.

duced by unfertilised queens and by fertile workers, being reared in worker cells, are abnormally small, and their production should be avoided.

## XI.—BREEDING FOR IMPROVEMENT.

**Crossing and Selection.**— All animals that man has domesticated have been more or less improved by breeding. Two methods have been employed, *crossing* and *selection*, and the best results have usually been obtained when they have gone hand in hand, the one followed by the other. Crossing effects a change at once, but it is only by selection that any permanent gain is obtained.

Unfortunately, very little permanent improvement has been yet obtained in the case of bees. This is chiefly due to the difficulty of controlling the mating of the queen. Mating takes place during flight, and a queen may be impregnated by any one out of the thousands of drones flying from colonies of all kinds dwelling within a radius of two or three miles. The obvious way to overcome the difficulty is to get the queens mated in a spot where none but drones of selected parentage are flying within the necessary radius for isolation, which has been estimated at from three to six miles, but no doubt varies under different conditions of temperature and weather. There is probably no spot in Great Britain or Ireland where isolation could be obtained except on high moors, bleak coasts, or islands, where low temperature and strong winds would render mating very precarious. Several mating stations have, however, been lately established, among the mountains of Switzerland, by the Swiss Bee-Keepers' Association, and no doubt Canada, with its vast tracts of unsettled country enjoying high summer temperatures, abounds in suitable places.

In Ripple Court Apiary selection by isolation has, of course, been impossible, but a method of selection by colour, described below under the heading of Mendelism, has been devised and carried out with some success.

The objection may be raised that, considering the

impossibility of knowing which drone out of hundreds a queen may meet, breeding by selection on the male side cannot be properly accomplished. But if we look at the work of plant breeders, we see that a similar uncertainty often exists as to which flower will supply the pollen by which the seed is fertilised. Further, in cases where characters that do not show themselves in the flowers, such as the size, shape, or other qualities of seeds or fruits, are bred for, the selection of flowers is useless. It is only essential that no flower shall be employed that is not of the selected parentage or strain. I think that even were it possible to select single drones for breeding from, it would not be advisable, for we may suppose that the honey-bee depends partly upon natural selection of drones for its vigour and usefulness. It is not asserted that one drone transmits exactly the same characters as another, but this uncontrolled element of variation is reduced to a negligible quantity by the employment of pure stock and continuous careful selection.

**Mendelism.**—Our knowledge of the laws of heredity has lately been much advanced by Mendelism, so named after its discoverer, Gregor Mendel, monk, and afterwards abbot, of Brünn in Austria, who announced its principles in 1865. In any attempt to improve livestock or plants by breeding, a knowledge of Mendelism is of great value.

Mendel made his classic experiments with the common garden pea. In one series of experiments he crossed a tall pea with a dwarf pea, and found that all the resulting hybrids were tall, like their tall parent. He named the character that prevailed in this first generation of hybrids—in this case of tallness—the *dominant*, and the character which disappeared, namely, shortness, the *recessive*. He sowed the seeds from these hybrids, and found they produced tall and shorts in the proportion of three to one. He was able to prove that the tall in the second generation of the hybrids were of two kinds, those that produced tall only, and those that produced tall and shorts in the proportion of three to one, like the tall in the first generation of the hybrids, and also that the latter kind of tall were twice as numerous as the former kind; and that the shorts produced shorts only. Mendel showed that this remarkable train of inheritance was true for six other pairs of characters in the pea, namely,

shape of seed—whether rounded or wrinkled, position of flowers—whether distributed along the stem or terminal, shape of ripe pod—whether inflated or constricted, and colour of seed skin—brown or white, cotyledons—yellow or green, and unripe pod—green or yellow.

The phenomenon of dominance, remarkable as it is, is not the essential part of Mendel's discovery, indeed, it is not present in every case, the first generation of the hybrids being sometimes intermediate in character. We must bear in mind that an individual animal or plant is the product of the union of two germ cells, or *gametes*, as they are called, the one derived from the male parent, and the other from the female parent. Thus an individual is of double origin.

Now the essential part of Mendel's discovery, recognised by the discoverer himself, is that the gametes are pure in respect of either of the characters in each of the pairs of alternative characters we have been considering; in other words, that a gamete can carry one of the characters of a pair, but not both.

In Mendelian language the individual animal or plant is called a *zygote*. If the two gametes that go to make a *zygote* carry the same character, the *zygote* is called a *homozygote*. If they carry opposite characters it is called a *heterozygote*.

By applying this theory to the results obtained by crossing the tall and dwarf peas, we see how perfectly it accounts for them. The individuals of the first generation contain and produce gametes bearing the elements representing tallness and shortness in equal numbers, and the results we get in the second generation are simply due to the segregation of these elements. As Bateson has remarked, the most striking consequence of Mendelian inheritance is the paradox that pure individuals may be bred from impure ones. Once the opposite character has been eliminated the individuals remain pure for any number of generations. Recent investigation suggests that the dominant may owe its dominance to a *factor* which is absent in the recessive; therefore we are not concerned with two opposing factors, but the presence or absence of a single factor. When the heterozygote is intermediate, we have no means of knowing in which of the two pure kinds of individuals the factor resides.

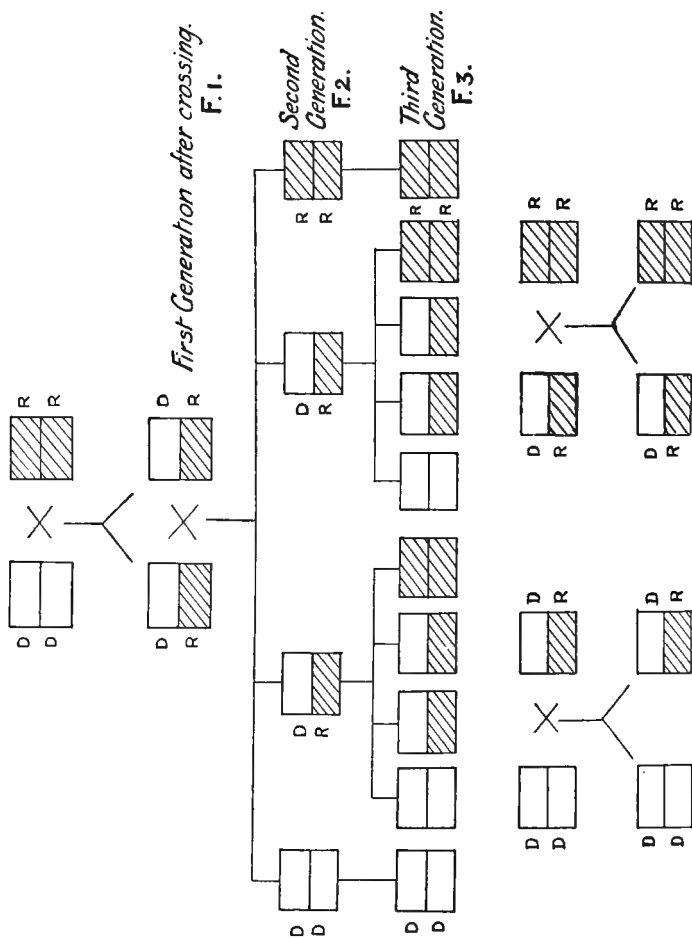

Fig. 33.

Diagram illustrating the Mendelian Scheme of Inheritance.



The Mendelian scheme of inheritance has been found to hold good for a great diversity of characters in plants and animals such as the absence or presence of horns in cattle, the pea comb and the single comb in fowls, the absence or presence of the waltzing habit in mice, and susceptibility or resistance to rust-disease in wheat, to mention only a few.

So far, we have considered the case of only one pair of differentiating characters in an individual, but the same results occur in the case of any number of pairs of characters. In the case of two pairs of differentiating characters we get, in the first generation of the hybrids, individuals all showing the two dominant characters. In the second generation we get nine individuals showing both dominants, three showing one dominant and one recessive, three showing the other dominant and the other recessive, and one showing both recessives. But it is not so easy to trace the results when there are several interacting factors modifying the same part or structure, or when the factors concerned fail to correspond with the characters that appear in the zygote, such as factors for inhibiting or developing colour.

Further complications are met with as the result of the repulsion and coupling of certain factors, including sometimes the factors for sex, the inheritance of which in some cases it appears to be possible to express in Mendelian terms. It is often hard to trace the inheritance of utility characters because they frequently are the result of many factors with differences so fine that they can hardly be recognised.

The study of Mendelism in the bee is hampered by several special difficulties. First, we cannot control mating in the ordinary way. Then there is the parthenogenetic production of the drone, which is likely to have a disturbing effect. Thirdly, the honey-bee is a highly specialised animal, and varies very little. There is some variation in size, the eastern races being smaller than those of the west, but apart from this the colour of the upper or dorsal side of the abdomen is the only visible character that varies strikingly. The variation consists in the extent to which the two colours, yellow and black, displace one another.

Turning our attention, firstly, to the workers, we find that in *Apis indica*, and in the artificial varieties known as golden bees, the yellow extends over the three basal

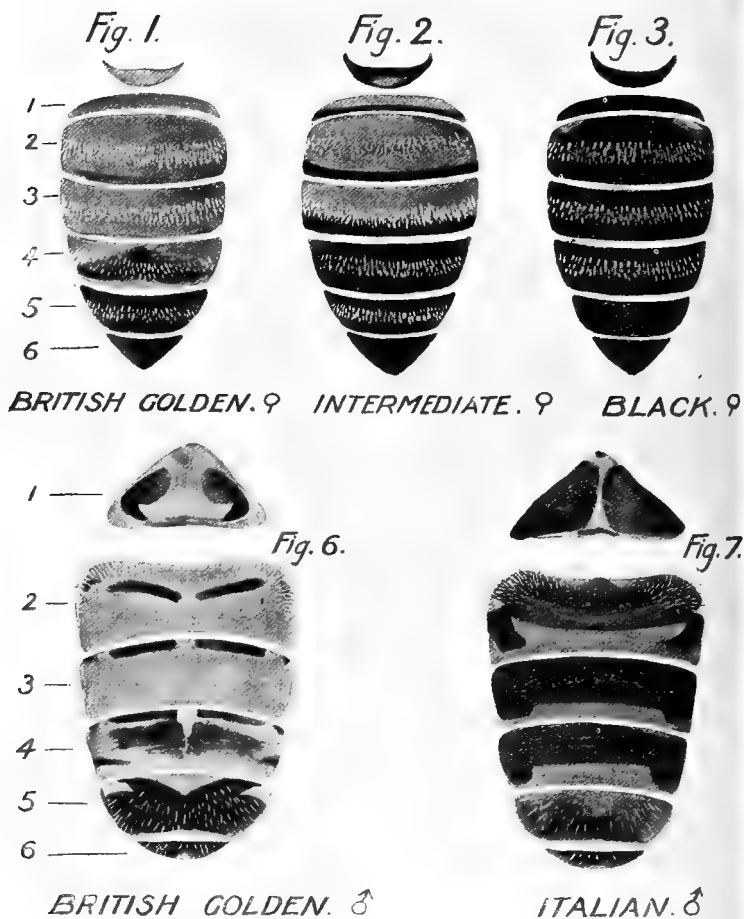

Fig. 34.

Diagram showing Colouring of abdomen of Workers and Drones.

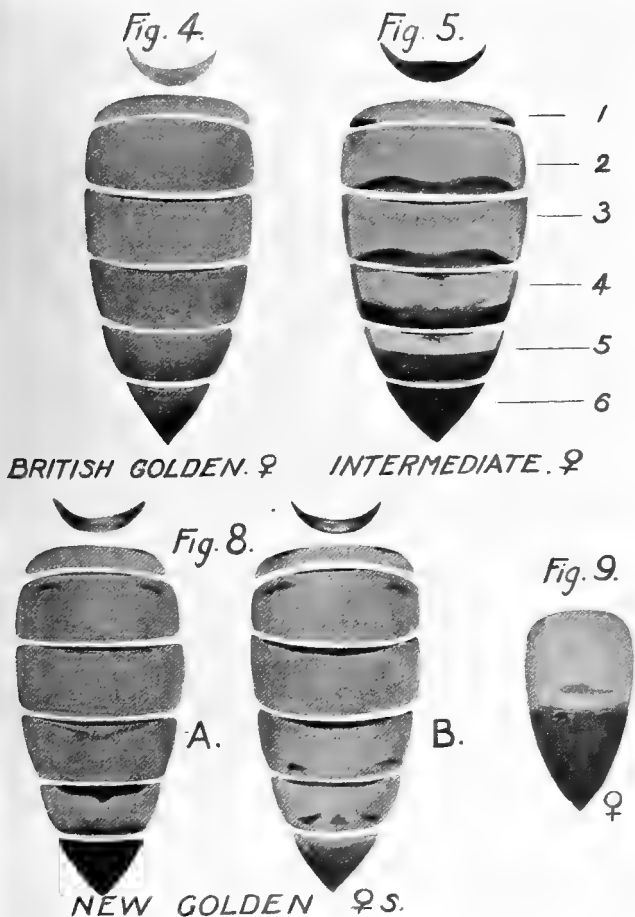

Fig. 34a.  
Diagram showing Colouring of abdomen of Queens.

segments, and more or less of the basal part of the fourth segment. The scutellum on the posterior part of the thorax is also yellow. Extreme goldens, with the fourth segment entirely, and the fifth segment more or less, yellow, have also been bred, but it appears that they do not breed true. In Italians the three basal segments are bordered at the edges with black and the scutellum is darker. Italians from the Swiss Alps have the black bands wider than Italians from the Ligurian Alps, while Cyprians have them narrower. Races with the abdomen entirely black occur in Britain, France, Germany, Malta and other places.

From 1901 to 1912 I was engaged, at Ripple Court Apiary, near Dover, in breeding a golden bee, to which I gave the name "British Golden." This bee was extracted from crosses between English blacks, Italians and American goldens. The golden character was soon isolated, and thenceforward it was found possible to maintain the pure golden breed by breeding from queens that produced all goldens, though, as may be imagined, many of the queens were mated with blacks and produced hybrids. No attempt was made to increase the area of the golden colour. The diagram (Fig. 1 in Fig. 34) shows the colouring of the abdomen of a pure British Golden worker. It is interesting to compare this with Fig 4, which is the colouring of the abdomen of a pure British Golden queen. It will be seen that the yellow in the queen extends much further than in the worker. The factor,\* or factors, that produce a half yellow and half black abdomen in the worker produce an almost entirely yellow one in the queen. There is no difference in the gametes; the difference is merely a fluctuation in the zygote caused by a difference in the quality and quantity of food supplied in the larval stage. Since the work of breeding British Goldens was begun in Ripple Court Apiary, in 1902, a very large number of pure golden queens have been bred; about 1,500 of them were kept until their young workers hatched, and notes were made of the colouring of these. These workers were of two types only, golden and intermediate (see Figs. 1 & 2 in Fig. 34). Not a single black worker was seen. Most queens produced a considerable proportion of each type, but some produced all goldens, and some all intermediates.

---

\* The word "factor" is here used in the Mendelian sense only.

It was evident that the queens that produced all goldens had been mated by a pure golden drone, and this was confirmed by the fact that the all-golden families were most numerous (1) from the matings that took place at the end of each season, namely, in August and September, when most of the drones in neighbouring apiaries had been killed off and only the golden drones in Ripple Court Apiary remained, and (2) from the matings that took place in cool and windy weather, and, therefore, close to the apiary.

Matings of the latter kind I have called by the name of "restricted matings." Most of them did not take place until the queens had been hatched twelve to fifteen days.

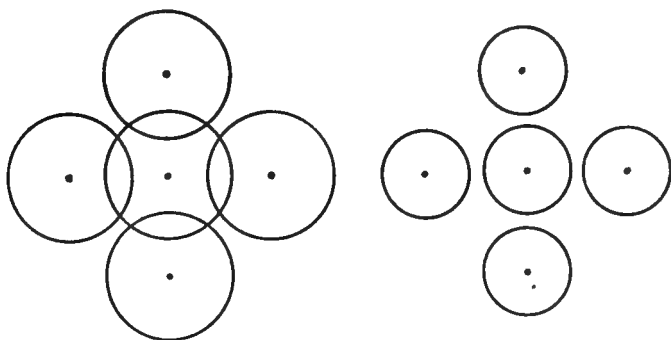

Fig. 35.

Diagram showing how a slightly restricted range of flight may completely isolate an apiary for breeding purposes. The dots represent imaginary apiaries, and the circles ranges of flight. The ranges of flight of queens and drones are not shown separately.

Ripple Court Apiary is a very favourable spot for restricted mating. The surrounding country is rather destitute of trees, and is much swept by cool winds, the prevailing north-easterly and south-westerly winds both blowing off the open sea, which is four and seven miles off in these respective directions. Perfectly calm days are rare. On sunny days in summer, when it is warm inland, the maximum temperature is generally about 5 degrees to 10 degrees lower and the wind stronger than in warm places inland. But there is more sunshine and the nights are warmer than inland.

The apiary is sheltered from wind by a belt of trees and shrubs, chiefly Austrian pine, goat willow, sycamore, and lime. Whichever way the wind blows, there is a sheltered area just outside the apiary in which, I believe, many queens have been mated. No bees are kept within half a mile of Ripple Court Apiary.

There was also evidence to confirm the opinion that the families consisting of all intermediates were the result of the union of the golden queens with pure black drones. Such families were not very numerous from matings that took place in Ripple Court Apiary, but out of five queens mated at a spot nearly two miles from the apiary four produced all intermediates, and one about nine intermediates to one golden.

Among the families that consisted of both goldens and intermediates, which it is reasonable to suppose were the result of mating with heterozygous drones, the two types appeared in varying proportions. A common proportion was about seven goldens to three intermediates, perhaps two to one, but the intermediates were sometimes in excess of the goldens. A case of 90 per cent. intermediates has just been referred to; and, at the other extreme, it may be mentioned that in 1912 I bred from a queen that produced about thirty goldens to one intermediate; the proportion of goldens to intermediates was the same in her queen progeny as in her worker progeny, and this has been so with every queen from which I have bred.

The queen corresponding to the intermediate worker is shown at Fig. 5 (in Fig. 34). Notice that she, too, is somewhat yellower than the corresponding worker, and that her scutellum is black, not yellow, as in the golden queen. The worker offspring of about thirty of these intermediate queens were examined, and in every case they consisted of goldens, intermediates, and blacks, thus proving that segregation of golden from black takes place. The proportions of the three forms varied in different cases, but the intermediates were usually greatly in excess of the goldens and the blacks. In many cases almost every degree of colouration between golden and black appeared, but not in equal numbers.

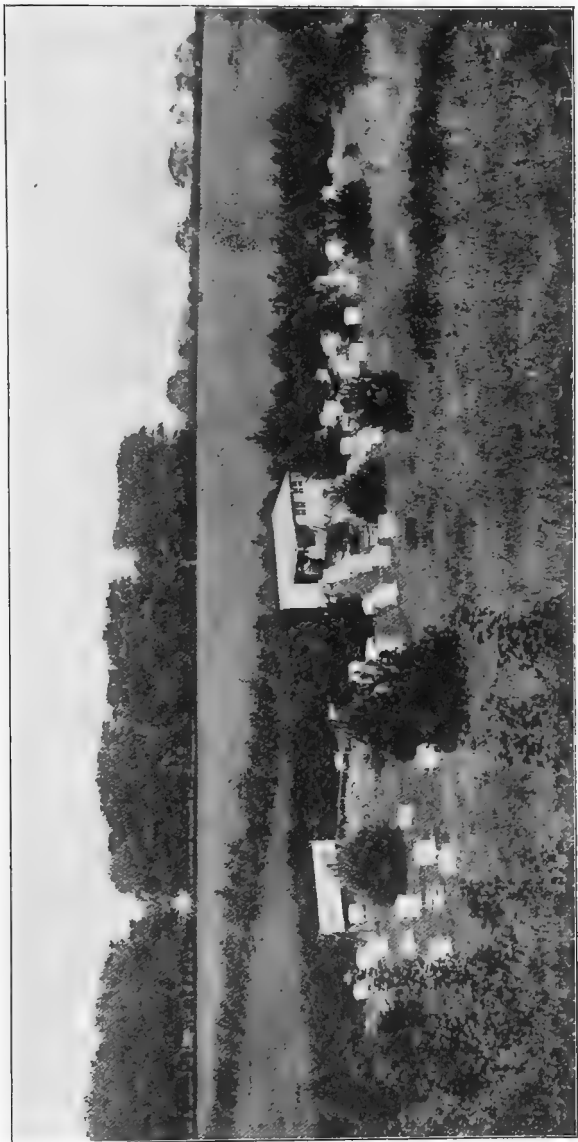

[Photo by H. Franklin & Son, Deal

RIPPLE COURT APIARY, NEAR DOVER.





Out of 475 workers produced by an intermediate queen bred in Ripple Court Apiary in 1912, practically every degree of colour occurred.

Eleven had the first three segments of the abdomen yellow, but the edge of the second segment slightly darkened, more so at the sides, and the third segment narrowly edged with black.

Forty-seven had the second segment narrowly edged with black, the third segment broadly so.

Two hundred and fifty-two had the first segment also narrowly edged with black, and the second and third segments more widely so.

Six had the abdomen black, with a yellow smudge across the second segment.

Sixteen had it black, with a large yellow spot on either side at the base.

Twenty-nine had it black with a small yellow spot on either side at the base.

One hundred and fourteen had the abdomen entirely black.

Out of eighty-three workers produced by a lighter intermediate queen, also mated this season, nearly every degree of colour was found, but the proportions were different.

Six had the first three segments yellow, the third being narrowly edged with black.

Ten had the second narrowly, and in the middle faintly, edged with black, and the black edging of the third segment wider.

Fifty-two had the first segment narrowly edged with black, and the second and third segments more widely so.

One had the first segment tinged with black, and the second segment broadly edged with black.

Six had the abdomen black, but a spot on either side of the second segment at the base yellow.

Eight had the abdomen entirely black.

A few Italian drones were flying in the apiary in 1912 (the first occasion in ten years), and one or both of these queens may possibly have been mated by one, but I do not think it probable.

In trying to analyse all these results, we find ourselves in the dark on a most important point, the drone fathers.

But we can see that they indicate Mendelian inheritance. Indeed, up to a certain point, the simple Mendelian rule seems to be followed. The golden queen mated by the black drone produces the heterozygous intermediate. Mated by the intermediate, she produces goldens and intermediates, but no blacks (see Fig. 33). Again, the intermediate mated by the intermediate produces a small number of goldens, a large number of intermediates, and a small number of blacks. But the appearance of every grade of intermediate in the second generation shows that we are here probably dealing with more than one factor, though, as Punnett has shown in the case of the cross between a "Silky" hen and a "Brown Leghorn" cock, there need not be more than two if it be assumed that they interact on one another in different ways and to different degrees.

It seems unprofitable to speculate further as to the inheritance of the golden and black characters in queen and worker till more evidence has been collected, and we may turn our attention to the more practical question of how far Mendelism can help us in our efforts to improve the bee. A lesson it teaches us—that is, perhaps, of greater immediate value than any other—is that if the characters that we want depend on the heterozygous nature of the heterozygotes, the way to get them is to breed together the two pure homozygotes. Thus from the union golden  $\times$  black we get all intermediates, whereas from the union intermediate  $\times$  intermediate we get only a proportion of intermediates.

Fortunately, hampered as bee-breeding is by great difficulties, the particular union, golden queen  $\times$  black drone, is practically attainable on a large scale, and, more fortunate still, the intermediate produced by it does possess certain qualities that are very desirable. In the first place, as in the case of heterozygotes in many plants and animals, it possesses the added vigour due to the crossing. This vigour shows itself in great energy, hardiness, and industry in honey gathering. The hybrids produce larger average yields of honey per colony than blacks. They are considerably larger than goldens (in both queen and worker) and slightly larger than blacks. With the cross under consideration, golden queen by black drone, which is the

only practicable one in England (the reciprocal cross, golden ♂ by black ♀, being only a chance production), the colonies are very populous because they are headed by golden queens, which are more prolific than blacks. An undesirable consequence of crossing bees is the development of an increased tendency to sting, but in this particular cross the temper is usually good, though it becomes hotter in later generations when the black colour predominates.

Reference has been made to the coupling of factors. Colour characters are often associated with various qualities of a useful nature or the reverse. Punnet states that the National Portrait Gallery furnishes remarkable evidence of this in man. Here the pictures of celebrated men and women are largely grouped according to the vocations in which they have succeeded. It is rare to find anything but *blue eyes* among the soldiers and sailors, while among the actors, preachers, and orators the *dark eye* is predominant, although for the population as a whole it is far scarcer than the light.

In the honey-bee several qualities are associated with the golden and black colours. The goldens are more prolific, they are also less hardy and smaller. They make a peculiar singing sound when they are smoked. These characters I have found inseparable from goldens. It is said that goldens are greater robbers than blacks, and that they distribute themselves more to neighbouring hives, but this I have not proved, and it is certain that they are more often detected doing these things on account of their bright outstanding colour than they would be if they resembled the bees whose hives they enter.

As regards desirable utility characters that are separately inherited, we are not in the near future likely to make much progress in unravelling the factors that stand for them, and even if we could do so, how can we fix them without controlling mating by isolation? In England there seems to be only one way, namely, by getting the character in our golden bee. During the last few years I have been trying to fix certain desirable qualities in my goldens. Having found the desirable quality in a stock, one must be prepared to sacrifice all one's other goldens in order to give it a chance to get fixed.

By, every year, wintering 30 to 50 of the purely mated British golden queens bred the previous year, carefully

comparing their colonies for hardiness and honey gathering in May and June, and breeding queens and drones from the best only, I was able to get some improvement in these directions, and a better bee for crossing with blacks.

A valuable lesson that Mendelism teaches to breeders of all kinds of plants and animals, and one that the bee-breeder must not lose sight of, is that, in the words of Punnett, "every possible variety arising from a cross appears in the second generation if only a sufficient number is raised, and of all these different varieties a certain proportion of each is already fixed." More can be accomplished by a careful analysis and isolation of the individuals of this generation than by years of breeding by selection on the old lines. The fear of losing the original variety by crossing it is unfounded, for it can be recovered in a fixed state with all the superadded vigour that follows from a cross.

We must remember that, underlying Mendelism, is the doctrine elaborated by Weismann: that characters acquired during the lifetime of the individual as the result of changes in treatment or environment cannot be transmitted to the offspring, though it is true environment may and does exert selection in individuals carrying different kinds of gametes. It is, therefore, useless to try to fix acquired characters—fluctuations, as they are called—by breeding, unless the treatment that causes them is always applied, as in the case of worker characters as distinguished from queen characters.

Robbing is generally an acquired character caused by carelessness on the part of the bee-keeper. Bad temper induced by improper handling is another case of an acquired character. Such characters, acquired by accident, need cause us little concern.

Most of the characters in the bee that we wish to improve are in the workers. How, it may be asked, can these be propagated, seeing the workers are sterile? We must do it through their reproductive sisters—the queens. It is comparatively easy to propagate the character if it is recognisable in the queens, even though much changed, as, for instance, the colour character. But we may wish to propagate a character that is not recognisable in the queen, such as industry. We may wish, for instance, to get the queen containing the factors carried by a particularly

industrious worker in a hive where most of the workers are less industrious. Unfortunately, we have no means of discovering such a queen, and characters of this kind that show themselves in individual workers are almost sure to be lost unless we can find them in a large proportion of the workers in a colony. For such characters we are compelled to test our bees in colonies, not as individuals. This is rather a serious limitation, for while we can study the characters of thousands of individual workers, comparatively few colonies are available. On the other hand, the enormous number of workers that a queen produces helps us very much in the study of what gametes she is producing, and as they are always surrounding her and continue to be produced for years, we can study them at leisure.

And here I may make a few remarks on estimating the proportions of the different coloured offspring of a queen. My practice is to do this, if possible, on the twenty-second or twenty-third day after the queen begins to lay. Then only a few hundred of her workers have hatched, and they can be distinguished at once from the other workers in the hive by their downy, soft, and immature appearance. At this stage one can, with practice, estimate fairly accurately almost at a glance the proportions, if only two types are present. Often there is a risk of robbing, and then it is not safe to keep the hive open more than a minute or two. Later, when there are workers in all stages of immaturity, it is less easy to estimate the proportions. It is not usually possible to ascertain the proportions from mature bees until the spring, and then the results may be rendered inaccurate by the presence of bees from other hives. For accurate work it is best to chloroform a few hundred bees, and then pick out the young ones and count out the different varieties of them before they have time to recover.

I should like to say a few words on colour inheritance in drones. Fig. 6 (in Fig. 34) shows a British golden drone. The drone has seven dorsal segments—one more than the worker or queen—but only five of these are seen from above, for the first segment occupies the basal end of the abdomen, and the last one is underneath. I should state that British Golden drones vary a little in the extent of the black on the fourth segment. It is well known that

the drone is produced parthenogenetically, *i.e.*, without sexual union. The production of a male by parthenogenesis is rather unusual in nature. More often, as in Aphids, it is the female that is produced parthenogenetically, and then the species can reproduce itself through several successive generations without fertilisation, and while this kind of reproduction is going on the male disappears completely. But with the bee this is not so. Fertilisation by the drone is needed for each fresh generation of workers and queens. Most of us have proved to our own satisfaction that the drone can be produced parthenogenetically. A colony loses its queen in winter, and a new queen is reared, which fails to get fertilised, with the result that she produces drones only. But are all the drones produced by a *fertilised* queen the result of parthenogenesis? Perez, in 1878, thought not, for on examining 300 drones produced by an Italian queen, fertilised by a French black drone, he found 149 which he thought indicated hybridism. It is clear that if it is true that the drone is always produced parthenogenetically, the queen, provided her gametes are pure, must produce pure drones, no matter what kind of a drone has fertilised her. I have bred drones from about half a dozen of my golden queens every season for some years. Some of these golden queens were producing all golden workers, others certain proportions of intermediates, others all intermediates. Now the drones from the queens producing all golden workers were all golden, as shown in Fig. 6, though they varied a little, as were also the drones from most of the queens producing some or all intermediate workers, but two of these queens produced certain proportions of darker drones. One of these was a queen raised in 1911. The workers she produced were all intermediates. On May 29th, 1912, I examined seventy-seven of her drones; twenty-six had the first four segments largely yellow, ten the fourth segment smudged with black, twenty-seven had only three segments yellow, the fourth segment being black, twelve had only two segments yellow, and two had the abdomen entirely black, with only the edges of the first and second segments yellow. One's first thought in trying to explain this remarkable result is to suspect that the queen was not producing pure golden gametes, but the facts that the queen had the

scutellum and the abdomen almost to the tip yellow, and that a queen thus coloured had never been known to produce a black worker, oppose this view. On the other hand, up to 1908, golden queens, with the scutellum darkened, were occasionally produced, and black workers were often bred from these, indicating they were heterozygous. But latterly the separation between golden and intermediate has been more complete, and such queens have not been produced.

This incomplete separation is additional evidence of the presence of more than one factor for colour. In review of the situation, the production by a golden queen of dark drones cannot be said, in the light of our present knowledge of the inheritance of colour, to upset the universally accepted and apparently well-founded theory that the drone is always produced parthenogenetically, but, in view of the fact that in all our efforts to breed bees this theory plays a leading part in guiding the operations, such cases as this that seem to shake it should receive the fullest investigation. If we could control mating they would be certain to add valuable facts to our knowledge of the inheritance of sex.

Fig. 7 is of an Italian drone bred from a queen received from Bologna. Some of the drones produced by this queen had a more distinct tinge of yellow on the second segment, but none showed so great an extent of yellow as that exhibited by the British golden drone. It was the great variation in the colouring of the Italian drone—some are almost black—that led Perez's critics—for his statement raised a storm of opposition—to reject his idea of hybridism.

The inheritance of colour in the Italian bee is remarkable in two ways. First, the workers all come perfectly true to a colour pattern very like that of the cross between golden and black, though somewhat darker as a rule, and varying in different localities. Secondly, the queens, on the contrary, show immense variation: some are almost as yellow as goldens, though they lack the yellow scutellum and they have at least traces of dark spots on the segments. Others are broadly banded with black and have the last segments black. Are these differences in the queen mere fluctuations, or do they stand for factors in the gametes which do not manifest themselves in the workers?

The breeding true of an intermediate condition of colour such as occurs in Italians has been found to be in accord with Mendelian views in a case where only two factors were concerned, when it was assumed that they interacted on one another in a certain way and to different degrees.

Fig. 8A shows a remarkable colouration found in a British golden, bred in 1912. Fig. 8B shows an unusual colouring in several golden queens reared in August, 1912, from a British golden queen bred the same year, that produced all goldens. Whether these are fluctuations caused by cold or some other agent, or whether they are new colourations, it is not yet possible to say; but I have always been on the look-out for variations in goldens in the direction of darkening, for it is probable that only by isolating such a variation shall we succeed in much improving the hardiness and honey-gathering qualities of goldens. That a chill during the later stages of development darkens the yellow colour and causes the black to spread in queens, every breeder of Italians or goldens knows. Fig. 9 shows a curious and striking distribution of colour that I have obtained in intermediate coloured queens chilled during development.

Till now we have been considering only the ground colour of the abdomen. But there is another character that greatly affects its appearance in the worker, and that is the presence or absence of a pronounced band of short white hair on each segment, except the first and the last. This band is well developed in the Italian bee, but feebly so in the English black bee. The only outstanding difference between the appearance of the English bee and that of the Carniolan is the high degree to which these bands are developed in the latter race. It would be interesting to ascertain if the inheritance of these bands follows Mendelian rules.

I am not without hope that swarming and even stinging may be eliminated by breeding.

In nature, the vast majority of queens are reared in colonies that swarm, but by modern methods of queen-breeding, colonies that never swarm may be bred from. British goldens that had been bred artificially through at least ten successive generations, regardless of swarming, were very uncertain in the way they swarmed. The swarms often issued late in the season and many returned to the hive without



settling. It is possible that this erratic behaviour is the result of the commencement of a disassociation of the units that go to make up the swarming impulse.

“Stingless” bees, in the sense that they do not insert their stings into human beings, are common in Asia, and there seems to be no reason why they should not be acclimatised in Britain or in any other bee-keeping country. When investigating the bees of India, in 1897, I paid a visit to the apiary of native bees kept at the gaol at Darjeeling (altitude 7,000 feet), in the Eastern Himalayas. These bees were always handled without the use of either smoke or veil. I myself examined a hive in this way, and I handled the bees roughly to see if it was possible to get them to sting, but it was not. An angry swarm gathered around my hat and head, and after I had left the hive twenty or thirty bees followed me wherever I went, but I gradually got rid of them by dodging behind bushes.

It would seem that stinging, which is really an act of defence, depends upon two characters, which may be inherited separately, (1) the flying to the molester and (2) the insertion of the sting into him. In our Western bees both of these characters are present, the former one in a modified degree. The Himalaya bees possess only the first. They only threaten to sting. But in honey-gathering they are probably much inferior to the European races.

In conclusion, I would again draw attention to the value of the bee produced in the first generation of a cross between two distinct breeds. When a bee-keeper introduces a new race or breed into his apiary he has two, not one, new bees to study, the pure breed and the half-breed, and in addition the host of varieties that follow in the second and later generations. The generality of bee-keepers do not sufficiently distinguish between pure breeds and half-breeds. The term “Italian,” for instance, is often applied indiscriminately to the young of an imported Italian queen, and the young of her daughters, reared and mated in Britain, and even sometimes to the later generations—in fact, to any bee that shows yellow bands. In this way many observations that have been made about Italians have failed to be of value, and have even been in conflict, one bee-keeper blaming them

for lacking the very qualities that another bee-keeper praises them for possessing.

One of the best qualities of Italians is their undoubted power of resistance to the disease that, in America, is known as "European Foul Brood," and I may now call "melting foul brood" to distinguish it from the ropy form. Whether this most useful quality is shared by the Italian-English half-breds, and, if so, to what degree, it would be well worth while to try to discover. The bee-breeder might succeed, with the aid of Mendelian methods, in separating a highly resistant strain, just as Professor Biffen, of Cambridge, has by this means been enabled to bring out a rust-resisting variety of wheat. We might, perhaps, breed a strain to resist what has proved in some parts of Britain to be a still greater scourge, the "Isle of Wight" disease.

The fixed types of bees that occur in nature in different localities should always be named after the localities from which they come, for variation in appearance is so limited that it often fails to enable one to separate one type from another.

An account of the work of breeding the British golden bee in Ripple Court Apiary was published in the *British Bee Journal* in December, 1909.

Those who wish to know more about Mendelism should read Professor Punnett's book, entitled "Mendelism."

## APPENDIX.

### A SCENT-PRODUCING ORGAN IN THE ABDOMEN OF THE WORKER HONEY-BEE.

It has long been known that bees, under certain conditions, particularly when swarming, will often, in vibrating their wings, make a peculiar hum, and that in so doing they attract their comrades. The attractive power has been supposed to lie in the sound of the hum, but some observations that I have made have led me to the belief that it is at least partly due to a scent which is emitted from a membrane situate between the fifth and sixth dorsal segments of the abdomen. Ordinarily, this membrane is covered by the fifth segment, but whenever the humming takes place it is exposed and the scent is then given off.\* The scent is pungent and suggests a mixture of that of iodine with that of formic acid. When humming and exposing the membrane, the bee stands in a particular attitude, the legs are extended and the tip of the abdomen is much raised, so that the exposed membrane occupies an elevated position. No doubt the vibration of the wings close to the elevated membrane distributes the scent in a very perfect manner.†

I first noticed the scent during the hiving of a swarm in July, 1900, when hundreds of bees were exposing the membrane. In March, 1901, while dissecting the abdomens of several freshly-killed bees, I noticed that one of them gave out the same scent. I then separated the membrane of this specimen with as little of the surrounding integument as possible, and placed it upon a piece of card. Here it emitted the scent strongly for some minutes, whereas the rest of the abdomen had no smell. On repeating the experiment with another abdomen, a similar result was obtained, but I found that not every specimen produced the scent.

By squeezing the abdomen of a freshly-killed bee so that

---

\* A vibration of the wings accompanied by little or no exposure of the membrane takes place at the entrance of the hive in very hot weather. This is evidently for ventilation.

† The legs are extended, the tip of the abdomen raised, and the wings vibrated feebly by the bees that thrust out their stings in alarm when a hive is opened. The sting poison, which gathers in little drops on the tips of the stings, has a strong scent, which resembles that of jargonelle, and has the effect of alarming other bees and inducing them to sting.

the tip is distended, a very good view of the membrane can be obtained (see Fig. 36 A). It is soft and semi transparent. The portion *b* has a milky-white appearance, and under the microscope it appears to be finely rugulose or covered with a large number of minute vesicules. At *c*, where the membrane joins the basal portion of the sixth segment, there is a long narrow channel, the basal part of which is also rugulose.

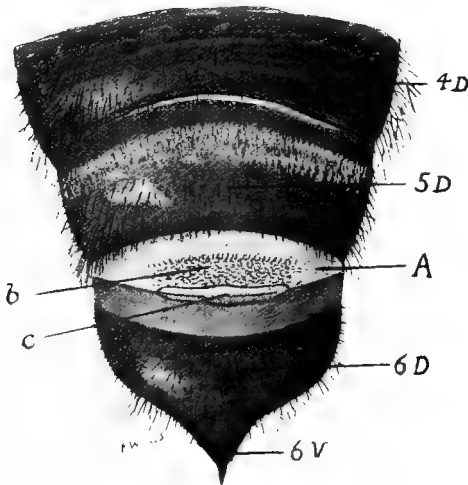

Fig. 36.

Tip of Distended Abdomen of Worker Honey Bee seen from above, enlarged.

4D, 5D, 6D.—Fourth, Fifth and Sixth Dorsal Segments.

6V.—Sixth Ventral Segment.

A.—Membrane. b.—Rugulose portion. c.—Nassanoff's canal.

It is the portion *b* and the channel *c* that are exposed when the bee is humming. It seems probable that the scent is produced by a liquid that is secreted in, and emitted from, the rugulose portion.

The organ in question appears to have been first noticed in the year 1883, when Nassanoff, of Moscow, described it, and an account of his description was sent by Zoubareff to the Swiss *Bulletin d'Apiculture*.

The organ is described as a canal. "At the bottom of this canal a large number of small glands open, each one of which has an oval cell with a well-defined globule. From each cell a duct starts out, and extends to the bottom of the canal." Nassanoff further said that the walls of the duct are of a chitinous texture. He assigned a secretory function to the glands, and suggested that they produced the perspiration. Zoubareff thought that the excess of moisture that is contained in nectar freshly gathered from flowers might be voided by these glands.\*

The humming, accompanied by the exposure of the membrane and production of the scent, takes place under the following several conditions:—

1. In a swarm, before it has settled down in its new hive. Here it is performed very freely, especially by the bees surrounding the queen when the main body of bees is separated from her, also by the bees that are the first to enter the new hive. The scent, when produced by a swarm, is very strong, and the attractive effect of the bees emitting it is very great. This effect is well seen if one removes the queen for about fifteen minutes and then places her in a spot a few yards from where the swarm is. As soon as a few bees discover the queen they settle close to her, and at once commence humming and exposing the membrane.† This soon attracts other bees, and these also hum and expose the membrane, with the result that the whole swarm is quickly drawn to the queen.

2. At the flight-hole of a hive. Here the action is performed either (*a*) by bees that are returning tired or benumbed by cold from the fields to the hive, this being chiefly in the evening or in unfavourable weather; or (*b*) by young bees on returning from their first flight, a number of these usually flying together about midday when weather is favourable; or (*c*) by some of the bees that are returning to their hive after their first flight following a long confinement in the hive, as in winter. In each of these cases the bees have been uncertain as to the exact position of the entrance to their hive, but when they discover it, no matter how feeble

---

\* See "The Honey Bee," by T. W. Cowan, 2nd ed., pp. 94 and 96.

† The queen herself has a strong attractive power, but the attractive power of a body of workers without her can easily be seen.

their condition may be, they will commence to hum and to expose the membrane. This action no doubt excites and warms them. It is usually intermittent, each interval being occupied in taking a few steps towards the interior of the hive; finally the bee disappears inside.

3. In certain artificial operations, such as when bees are being "driven" from one hive into another, or when a number of bees are shaken into a box or on to the alighting board of the hive. (This is one of the simplest ways of demonstrating the phenomenon.)\*

Under all these conditions there is a risk of loss of many bees either by their isolation, which may mean death by cold or starvation, or by their entering by mistake the wrong hive in which they may be killed, and it is the bees that have escaped from these dangers that attract the others still exposed to them; they draw them to the place of greatest safety, either to the queen or to the interior of the hive, or, when these places are not known, to where there is a large number of bees. A result of this arrangement is that when the number of bees in danger of failing to reach the place of safety is increased, these bees are more strongly attracted to it, because the number of those which succeed in reaching it is increased, and so large numbers of bees are not easily lost. A certain number of tired or young bees make themselves attractive as they enter the hive on almost every day when bees are flying, and no doubt during the whole season the loss of a very large number of bees is prevented by this action.

A constant waving of the antennæ during the humming and exposure of the scent-producing organ indicates that the attractive impression is received by the antennæ.†

\* The "roaring" of queenless bees is also accompanied by exposure of the scent organ. Here its use would seem to be to attract the lost queen.

† That the antennæ are used by bees for perceiving smells is shown. I think clearly by the following incident. In May, 1895, I captured a queen of the bee *Psithyrus vestalis* in the act of searching for a colony of the humble-bee, *Bombus terrestris*, in the nest of which *P. vestalis* breeds. I put her into a glass jar in which I had kept some *terrestris* queens for several hours so that the jar had acquired the characteristic odour of this bee. The *Psithyrus* queen showed plainly that she understood that *terrestris* queens had been in the jar for she ran about in great excitement, stroking the interior of the jar with her antennæ, apparently trying to trace the path the queens had taken. After a few minutes hunting she flew out of the jar, but finding she had lost the scent, she returned almost immediately to search again inside.

## HOW POLLEN IS COLLECTED BY THE HONEY-BEE AND BUMBLE-BEE.

### THE PART PLAYED IN THE PROCESS BY THE AURICLE.

All are familiar with the masses of pollen—red, yellow or white as a rule, but occasionally crimson, green, brown or black—that the bees collect and carry home on their legs. Catch a bee and you will see that the mass is attached to the outer side of a certain joint, namely the **tibia** or shank (1, Fig. 37) of the hind legs. The outer side of this joint has its surface smooth and nearly flat. Surrounding it is a wall of stiff bristles (9, 9) which hold in the pollen in the same way that the stakes that the farmer places round his wagon hold in a load of hay. This pollen basket was called by Kirby the **corbicula**.

Let us now turn our attention to the next joint below the tibia, namely the **metatarsus**.\* (2, Fig. 37). This joint which may be described as a rectangular plate, has its upper basal corner produced into a peculiar ear-like process (5, Fig. 37), which Kirby called the **auricle**. The function of the auricle appears never to have been closely studied, though Kirby, on page 210 of his *Monographia Apum Angliæ*, vol. I., published in 1802, suspected that it assisted in "kneading the pollen grains into a paste." Subsequently, however, its use in the honey-bee came to be regarded as forming with the end of the tibia, which is shaped to receive it, a pair of pincers to seize and remove the wax scales that form on the underside of the abdomen and this function is assigned to it in several of the present-day text-books on the honey-bee. In 1911, feeling dissatisfied with this explanation, more particularly because the wax of the bumble-bee, which also possesses the auricle, is soft and sticky, I examined the auricle and the adjoining parts in a worker bumble-bee of the common British species *B. ruderatus* that had been captured in the act of collecting pollen, and I found that the space between the auricle and the end of the

---

\* Called also the *planta* (Kirby), and the *basitarsus* (Cockerell). This is really the first joint of the foot.

**Missing Page**



tibia was crammed with pollen, this substance extending in an unbroken mass into the corbicula. It then occurred to me that the use of the auricle might be to push the pollen into the corbicula, and upon looking for confirmation, I saw a beautiful apparatus for carrying out the work as I had imagined.

An account of this apparatus and how it evidently works, was given in an article of mine, published in the *British Bee Journal* of Dec. 14, 1911, and in the following spring I was able to present further evidence to prove that it is employed in the way there explained. See the *British Bee Journal* of April 11, 1912.\*

We may commence the study of the process of pollen-collecting by noting that the metatarsi of all three parts of legs are clothed on their inner sides with brushes of stiff bristles. Now these brushes occur in the solitary bees as well as in the honey-bee and bumble-bee. Their function is to brush clean the coat of fur that clothes the body, more especially to clean out of it the pollen with which the bee, when it visits the flowers, gets dusted. The brushes on the fore metatarsi are used especially to clean the head and tongue, the brushes of the middle metatarsi to clean the thorax, and the brushes of the hind metatarsi the abdomen. If we catch a honey-bee in the act of collecting pollen we shall find that the brushes on the hind metatarsi are filled with pollen made into a paste with some kind of liquid, and if we taste the pollen we shall be led to conclude, by its sweetness, that this liquid is honey. Passing over, for the moment, the question of how the pollen gets moistened with honey and accumulates on the hind metatarsal brushes, we may ask: How is it transferred from these brushes to the corbicula? Cheshire (*Bees and Bee-keeping*, 1886, Vol. I., page 131) states that the legs are crossed, and the metatarsus naturally scrapes its brush on the upper edge of the opposite tibia, but this I find is not the case. If a

---

\* Dr. D. B. Casteel in a paper published Oct. 4, 1912, as Circular No. 161 of the Bureau of Entomology of the United States Department of Agriculture, entitled *The Manipulation of the Wax Scales of the Honey Bee*, states that the so called wax-pincers have nothing whatever to do with the removal of the wax scales, but that the wax scale is pierced by a few of the stiff spines on the distal end of the metatarsus and is then drawn from its pocket and remains adhering to these spines until removed for mastication. See also *The Anatomy of the Honey-bee*, 1910, by R. E. Snodgrass, p. 68.

bee be watched collecting pollen, it will be seen that the hind legs are never crossed, but that they are constantly rubbed together in a longitudinal direction. At the end of the tibia is a comb (3, Fig. 37). When the legs are being rubbed together the comb of the one leg scrapes the pollen out of the metatarsal brush of the other leg into the receptacle 4, which I have named the **excipula**. The leg, previously bent, is now straightened (see Fig. 38), with the result that the auricle closes on the excipula, compressing the pollen in it and forcing it up over its edge into the

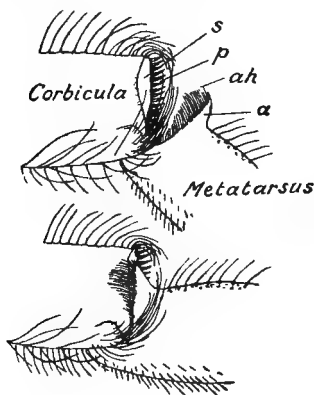

Fig. 38.

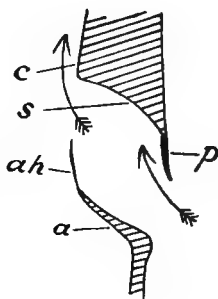

Fig. 39.

Figs. 38 and 39. Diagrams to illustrate the working of the corbicula-loading apparatus in the honey-bee. *p*, comb; *a*, auricle, *ah*, guiding fringe of hairs on auricle; *s*, excipula; *c*, entrance to corbicula.

corbicula at a spot (8) where there is a gap in the surrounding fence of bristles. The auricle bears a fringe of hairs (7) directing the pollen into the corbicula. This process is repeated many times with both legs. The result is that the pollen collects, first at the distal end of the corbicula, then spreads, as it increases, over the floor of the corbicula, and finally rises and swells into a great lump bounded by the surrounding fence of bristles. After the floor of the corbicula has been fairly covered with pollen, further contributions are forced in as a wedge between the

surface of the corbicula and the pollen already collected. This is seen in Fig. 40, which shows a pollen mass in the corbicula of a honey-bee caught early in April, 1912, consisting of white pollen, to which had been added a little orange pollen. It is also indicated in Fig. 42, which is an untouched micrograph of the two loads, cut in half, from the corbiculæ of a worker of a bumble-bee, *Bombus terrestris*, caught on July 23rd, 1912. In the course of loading

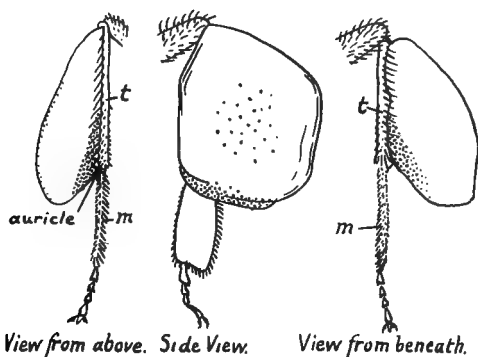

Fig. 40.

Left leg of British Golden Honey-bee loaded with two kinds of pollen.

*t*, tibia bearing the corbicula or pollen-basket. *m*, brush on metatarsus. The clear portions of the loads consist of white pollen (loaded first), the closely dotted portions of orange pollen (loaded later), and the remotely dotted portions of pale orange pollen; the latter, where it is shown detached from the orange, is on the surface only.

up this bee changed from white pollen to yellow or orange, and from yellow or orange to white no less than seven times, and the stratification caused by the successive changes is very instructive.

The bee keeps the growing load in shape by patting it occasionally with the metatarsus of the middle leg. The exact region thus patted is shown in Fig. 40 (middle drawing) as a remotely dotted area consisting of orange pollen added by the patting.

Casteel has lately pointed out that when the pollen grains are small, and the whole mass in the corbicula is well moistened, marks made by some of the corbicular bristles will be seen on the sides of the load. These scratches are transverse in direction, and show that the mass has been increased by the addition of pollen pushed up from below.\*

The bumble-bee is the only bee besides the honey-bee outside the tropics that possesses a corbicula, and she loads it with pollen in essentially the same way as the honey-bee, but the apparatus employed is less specialised. On reference to Fig. 41, it will be seen that the bristles comprising the hind metatarsal brush are arranged, not in rows, but irregularly, as in the solitary bees. The pollen paste is found only in the corner of the brush nearest to the auricle, which is the only part of the brush scraped by the comb. Only the upper end of the comb comes into contact with the brush. The teeth at the lower end of the comb are, in fact, useless, being slender and hair-like (see Fig. 44), whereas in the honey-bee every tooth is well formed (Fig. 45). Indeed, the bumble-bee's comb shows very plainly that the teeth of the comb in both bees are nothing more than specialised hairs. In the bumble-bee the tips of the teeth form a nearly straight line, but in the honey-bee they form a convex curve, thereby making the comb an efficient instrument for combing out the whole of the metatarsal brush. The tibial spurs (Fig. 44, *s, s*) would impede the working of so perfect a comb as that of the honey-bee and, though present in all other bees, are absent in *Apis* and its tropical allies, *Trigona* and *Melipona*. At the base of the comb in each bee is a glabrous or naked area (*g*), which indicates by its width what part of the comb is most used.

In the honey-bee the working surface of the auricle is covered with numerous small pointed teeth (6, Fig. 37) inclining in the direction that the pollen moves, but in the bumble-bee the surface is smooth.

The entrance to the corbicula, named by me the *límen* (8, Fig. 37) is worth a moment's attention. In the bumble-bee its edge is covered with short fluff consisting of fine branched hairs. Further in stand about three stiff bristles

---

\* *The Behaviour of the Honey-bee in Pollen Collecting*, by D. B. Casteel, Ph.D., U.S. Bureau of Entomology, Bulletin No 121, published Dec. 31, 1912.

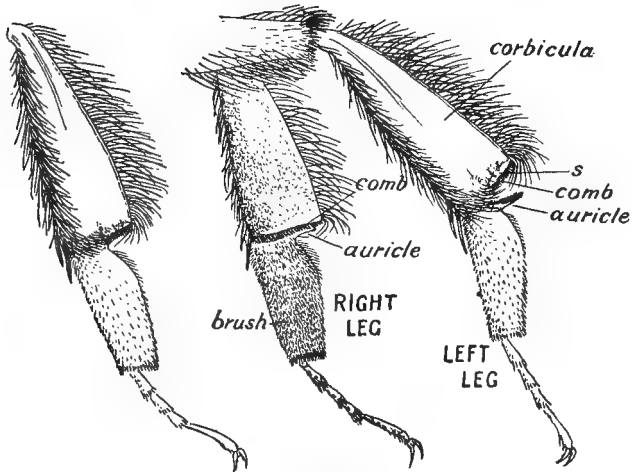

Fig. 41.

Pollen collecting apparatus on the hind legs of the humble-bee (*Bombus terrestris*, queen).



Fig. 42.

Sections through variegated pollen masses from the corbiculae of a worker of *Bombus terrestris*.

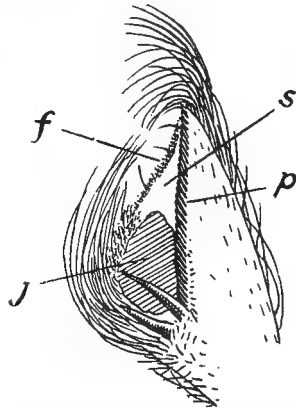

Fig. 43.

*Bombus terrestris*, queen, end of tibia, left hind leg. p, comb or pecten; s, excipula; f, entrance to corbicula; j, juncture of tibia with metatarsus (this is the ball and socket point, the socket being here shown).

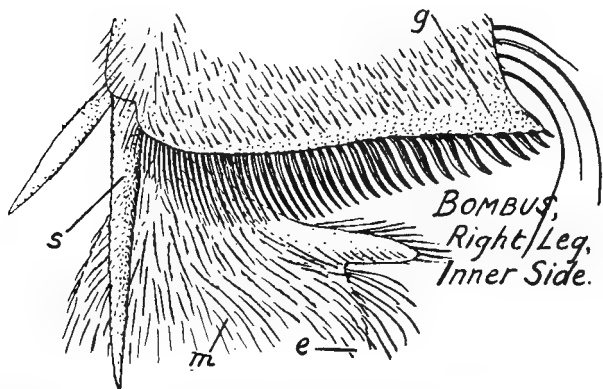

Fig. 44.

Tibial comb of right hind leg of *Bombus terrestris*, worker, inner side. s, inner spur; g, *pars glabrum*; m, metatarsus brush; e, part of metatarsal brush that bears moist pollen.

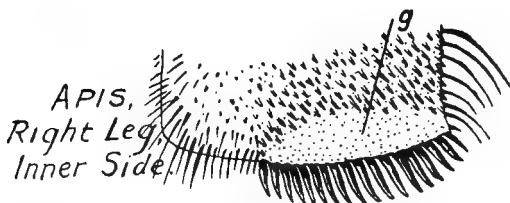

Fig. 45.

Tibial comb of right hind leg of *Apis mellifica*, worker, inner side. g, *pars glabrum*.

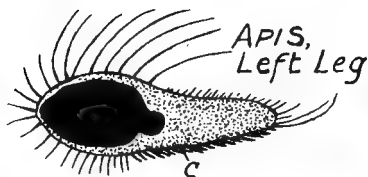

Fig. 46.

Distal end of left tibia of *Apis mellifica*, worker, end view, showing excipula and limen; c, comb.

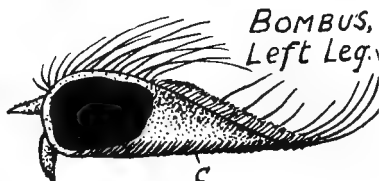

Fig. 47.

Distal end of left tibia of *Bombus terrestris*, worker, end view, showing excipula and limen; c, comb.

leaning towards the entering stream of pollen. These bristles form a means of attachment to the corbicula for the pollen mass before it has grown large enough to be held by the bristles at the sides. In *Apis* the fluff is scanty, and there is only one long impeding bristle (10, Fig. 37). In both bees the entrance to the corbicula is overarched by the bristles on either side (see Figs. 37 and 43). This arch helps to support the accumulated mass of pollen while allowing fresh pollen to pass in freely underneath it.

It is evident that the honey with which the pollen is moistened comes from the mouth. Some authors have supposed that the honey is removed from the mouth on the feet, which are thus rendered sticky, so that the pollen dust clings to them; others that the pollen dust is conveyed to the mouth to be moistened. It is true that I have found occasionally a minute ball of moistened pollen in the mandibles of pollen-collecting bees, but this might be accounted for by the fact remarked by Hommell, and later by Crawshaw and Casteel, that the mandibles are used to some extent in collecting pollen from the flowers. In the case of such flowers as white arabis, wallflower, and red ribes, the pollen is entirely gathered in the region of the mouth.

Casteel, in his recently published paper, *The Behaviour of the Honey-bee in Pollen Collecting*, considers it is extremely difficult to determine with absolute accuracy the essential steps involved in the process of adding moisture to the pollen. He states, however, that the honey from the mouth becomes well distributed over the brushes of all the legs, and that "all of these brushes also transport wet pollen which has come from the mouth parts, and thereby acquire additional moisture. The auricles and the plantæ of the hind legs become particularly wet from this source, since fluid is squeezed from the wet pollen when it is compressed between the auricles and the distal ends of the tibiæ. Dry pollen which falls upon the body hairs becomes moist when brought into contact with the wet brushes or with wet pollen. During the process of manipulation pollen passes backward from its point of contact with the bee toward its resting-place within the baskets."

I have noticed that the pollen on the brushes of the hind legs is much more moist than that on the brushes of the fore

and middle legs. This greater wetness of the pollen on the hind legs may very well be accounted for partly, as Casteel points out, by the squeezing of the pollen between the auricle and the tibia, and partly by the fact that, by the frequent rubbing of the pollen-laden hind legs together with the addition of little or no dry pollen, the moisture is brought to the surface, just as when one works up a ball of dough it becomes sticky and clings to the board and rolling-pin if one does not keep adding flour.

It is well known that the honey-bee collects propolis in its corbiculæ. Thinking it would be impossible for it to pass such a sticky substance through the leg into the corbicula as it does pollen, I exposed a propolised quilt in my apiary to the warm sunshine on a sunny day in March, 1912, and watched to see what would happen. A bee soon alighted, and after making several futile attempts, succeeded in detaching with its mandibles a little bit of propolis. Seizing the fragment in its fore legs, it dashed it into the left corbicula with the left middle leg, and immediately afterwards patted it with the metatarsus of this leg. Further fragments were detached with the mandibles and the bee succeeded in dashing many of them into its corbiculæ in the same manner as before, some of them being conveyed by the left middle leg to the left corbicula, and others by the right middle leg to the right corbicula.

Thus the honey-bee loads its corbicula with propolis in an entirely different way to that in which it loads it with pollen.









