

CORNELL
UNIVERSITY
LIBRARY



FROM

The Dept. of Zoology

Cornell University Library
QL 47.K41

Zoology for medical students:



3 1924 024 761 128

oIn

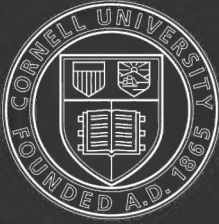

Cornell University Library

The original of this book is in
the Cornell University Library.

There are no known copyright restrictions in
the United States on the use of the text.

ZOOLOGY FOR MEDICAL STUDENTS



MACMILLAN AND CO., LIMITED
LONDON • BOMBAY • CALCUTTA • MADRAS
MELBOURNE

THE MACMILLAN COMPANY
NEW YORK • BOSTON • CHICAGO
DALLAS • SAN FRANCISCO

THE MACMILLAN CO. OF CANADA, LTD.
TORONTO

ZOOLOGY

FOR

MEDICAL STUDENTS

BY

J. GRAHAM KERR

REGIUS PROFESSOR OF ZOOLOGY IN THE UNIVERSITY OF GLASGOW

MACMILLAN AND CO., LIMITED
ST. MARTIN'S STREET, LONDON

1921

PREFACE

THIS volume represents in book form the Lecture course in Zoology for medical students as it has evolved during recent years in the University of Glasgow.

The task of designing and conducting a course in Zoology that will play its proper part in the education of the graduate in medicine is no light one. It is made immensely heavier by certain conditioning factors, above all in the case of our Scottish universities, by the compulsory limitation of the course within a period of ten weeks. This renders it necessary for the teacher to confine himself rigidly to those parts of the subject which can really justify the expenditure upon them of the necessary time from the short period available.

In deciding what portions of the vast science of Zoology satisfy this condition, the teacher has to be guided by certain governing principles. Above all he must have clearly defined in his mind what he regards as the main objects of his course. So far as the present writer is concerned he has kept before him three objects which he believes to be of pre-eminent importance.

I. To awaken and develop, so far as the animal kingdom is concerned, interest in biological science. Medical students are training themselves to be efficient practitioners of a particular department of applied biology. It is of vital importance that they should become inspired at the earliest possible stage in their curriculum with a living interest in the study of the animal body. One of the first endeavours then of the teacher of Zoology should be to cast over the minds of his pupils some of the fascination of the most fascinating of sciences, so that they may pass on their way quickened and inspired by the stimulus of its interest.

II. To lay an adequate foundation for the superstructure of detailed knowledge of the animal body imparted in the courses of Anatomy,

Physiology, and Pathology, with their clinical applications in the later parts of the curriculum.

III. To provide a reasonably up-to-date account of the more important animal parasites, more especially of the pathogenic microbes of animal nature, and of the ways in which they are carried or harboured by members of the animal kingdom other than man.

Of these objects the last mentioned, though seeming at first sight to be very important, is actually of far less importance than the first two; for specialized knowledge of the type indicated can readily be added at a later stage, provided always that a sound foundation of general zoological knowledge has been laid. Many teachers indeed favour its relegation to a special course at a later stage of the medical curriculum. The present writer is on the whole in favour of retaining it in the general course in Zoology: (1) because the later parts of the curriculum are already much complicated by the multiplicity of subjects, and tend to become more and more so with increase of specialization; (2) because various parasitic forms of life are best studied along with their free-living allies; and (3) because many of the animal organisms that would naturally come into such a specialized course can quite well be made use of in the general course.

The course represented by this book is preponderatingly morphological, and this for two reasons. Firstly, because our knowledge of the morphological features of the lower types of animal is much more advanced than our knowledge of their physiology. Secondly, because morphological study affords an intellectual discipline better adapted to the needs of the elementary student than that afforded by physiology. The student observes structural features in the laboratory, and he records his observations in the form of drawings. He receives valuable training in observation and in the interpretation of observations; and he is able to compare what he observes with what he is told or reads. When, on the other hand, he tries to make physiological observations he finds even in the case of the simplest phenomena that behind these phenomena are at work unseen powers and factors, unobservable and yet perhaps all-important. He is taught that particular phenomena are due to metabolism or to some obscure process of a physical or chemical character—but these are, so far as he is concerned, transcendental, and as far beyond his powers of comprehension or criticism as if they were the direct result of supernatural agency.

The general lecture course in Glasgow is accompanied by laboratory work extending over a hundred hours. In great part this follows the usual lines such as are laid down in Marshall and Hurst's Text-book, but a special feature is made of the study of a valuable series of demonstration specimens. This includes the study, under high-power immersion objectives, of such organisms as Trypanosomes, Malarial Parasites, Leishmanias, and Spirochaetes. Experience has shown that students fully appreciate the privilege of being able to examine such preparations for themselves, and that they take the greatest care not to do damage. Opportunities are also given for seeing Trypanosomes, Miracidia, Cercariae, and so on, in the living condition. This demonstration part of the course is regarded as being of special value in arousing and gripping the interest of the student.

Time limitations have made it necessary to exclude the anatomy of the higher vertebrates from the course in Zoology. This has been done with regret for, apart from the intrinsic interest of the comparative anatomy of the higher vertebrates, it is of advantage to the student to obtain a superficial view of mammalian structure—such as he gains by the dissection of a rabbit or rat—before he submerges himself in the minute detail of human anatomy. But time limitations are inexorable, and the time available for the regulation curriculum in medicine being what it is, the indications seem to the present writer clearly to point to the necessity of restricting the anatomical study of the higher vertebrates practically to the anatomy of man. If the student of medicine desires, as he ought, to broaden his anatomical outlook by excursions into the comparative anatomy of the higher vertebrates, these will come most profitably after he has spent some time at human anatomy. In Glasgow special lectures on Vertebrate Morphology for such students are given during the summer term.

Another short supplementary course of lectures deals with the Theory of Evolution—The Evidences of Evolution, Inheritance, Variation, Natural Selection. Attendance at this course is voluntary, and its subject matter is not included in the medical degree examinations, but a large proportion of students attend it after going through the regulation course.

The illustrations in this book have been drawn by my friend, Mr. A. Kirkpatrick Maxwell, to whose artistic skill I am again under a deep debt of gratitude. "Line" has been employed rather than "half-

tone," for the practical reason that line diagrams are more easily copied. So long as examinations retain the place they hold at the present time in university curricula, it may be assumed safely that students will continue to use this method of impressing anatomical facts upon the memory.

In conclusion, I have to express my indebtedness to three friends and colleagues—to Mr. James Chumley and Dr. M. Taylor, who have read the whole volume in proof, and to Dr. J. S. Dunkerly, who has given me the advantage of his advice and criticism as regards the chapter on the Protozoa.

J. GRAHAM KERR.

28th June 1921.

CONTENTS

	PAGE
CHAPTER I	
PROTOZOA	I
CHAPTER II	
METAZOA—INTRODUCTORY REMARKS: COELENTERATA	84
CHAPTER III	
PORIFERA	118
CHAPTER IV	
ANNELIDA	129
CHAPTER V	
THE PARASITIC WORMS	159
CHAPTER VI	
ARTHROPODA	209
CHAPTER VII	
MOLLUSCA	267

CHAPTER VIII

ECHINODERMATA .	PAGE 282
-----------------	-------------

CHAPTER IX

INTRODUCTION TO THE VERTEBRATA: DESCRIPTION OF THE DOGFISH AS ILLUSTRATING THE GENERAL STRUCTURE OF A VERTEBRATE .	291
--	-----

CHAPTER X

FISHES .	347
----------	-----

CHAPTER XI

INTRODUCTION TO TETRAPODA: AMPHIBIA	402
-------------------------------------	-----

CHAPTER XII

AMNIOTA: REPTILIA, AVES .	419
---------------------------	-----

CHAPTER XIII

MAMMALIA	436
--------------------	-----

CHAPTER XIV

ELEMENTS OF VERTEBRATE EMBRYOLOGY	449
-----------------------------------	-----

INDEX	477
-----------------	-----

CHAPTER I

PROTOZOA

IN commencing the study of Zoology it is advisable to do so by making a study in some detail of one particular type of animal, so as to obtain definite and precise data to serve as a foundation for further knowledge. It is also desirable to select as the object of this study some animal possessing the minimum complexity of structure so that the beginner may easily grasp from it what are the fundamental features of animal organization.

Such a creature is the little animal called *Amoeba proteus* which is to be found still surviving on the Earth to-day, as a not uncommon inhabitant of freshwater pools and slowly moving streams, although it represents a relatively very early stage in the evolution of animal life.

AMOEBIA PROTEUS

The Amoeba consists of a minute particle just visible to the naked eye—measuring up to about .6 mm. in diameter—of that substance or mixture of substances which we call **protoplasm** and which Huxley used to speak of as the “physical basis of life”—because the condition which we call **life** occurs, so far as we know, only as an attribute of this substance. Wherever you find life there you find protoplasm. It would be of course of tremendous interest to obtain exact knowledge of the chemical and physical constitution of protoplasm because once this knowledge was obtained it would be but a comparatively small step farther to *produce* protoplasm—to make it in the laboratory. But unfortunately this knowledge has eluded—and probably must for ever elude—discovery, for the very first steps in the investigation—the first steps of chemical analysis—are such that they deprive the protoplasm of its all-important characteristic—that of living—the property which marks it off from all other substances.

It is naturally of interest, though of relatively minor interest, to

inquire as to the composition of the remains of the protoplasm which are left when the life has departed from it. Analysis shows that these consist of a mixture of those complicated substances known to the chemist as **proteins**—compounds of Carbon, Oxygen, Hydrogen, Nitrogen and Sulphur in about the following percentages: C52, O23, H7, N16, S2. Chemists are not yet able to tell us precisely how the atoms of these various elements are united to form the very complex molecules of the various kinds of proteins.

The student of living things is, for the reason indicated above, to a great extent debarred from using what to the Chemist or Physicist is his most powerful instrument of investigation, the method of **analysis**, whereby the complicated subject of investigation is split up into its simpler components and these studied individually. He is therefore driven to make his main stand-by the method of mere observation—in the case of small creatures like *Amoeba* with the aid of the microscope.

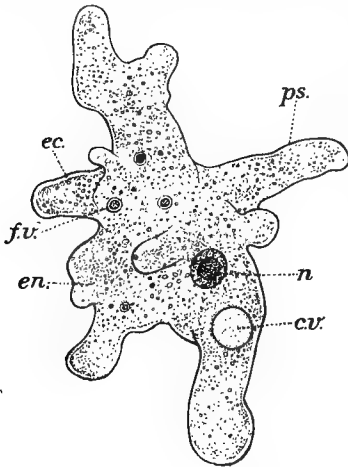

FIG. 1.

Amoeba proteus. *c.v.*, Contractile vacuole; *ec.*, ectoplasm; *en.*, endoplasm; *f.v.*, food-vacuole; *n.*, nucleus; *ps.*, pseudopodium.

When the living *Amoeba* is observed under the microscope it is seen (Fig. 1) to form an irregularly shaped blob of protoplasm—greyish white when seen against a dark background, clouded and finely granular when seen against a light background. The irregularity of form is characteristic and no two specimens are exactly alike.

Examination under a high magnification shows that the blob of protoplasm is not homogeneous but consists of a main larger portion known as the **cytoplasm**, and embedded in this a rounded denser portion—the **nucleus** (Fig. 1, *n*).

The cytoplasm is further seen to consist of a main portion known as the **endoplasm** (Fig. 1, *en*) and a thin superficial layer—the **ectoplasm** (Fig. 1, *ec*). Of these the endoplasm is fluid in its nature and is laden with minute particles which give it its very characteristic granular appearance. By the use of very high magnifications and the application of appropriate tests it can be determined that these granules differ in character. Some are droplets of fat, some are crystals of waste

material (such as Calcium phosphate), some are drops of watery fluid and these when they are of considerable size are known as **fluid vacuoles**. Small bubbles of Carbon dioxide (**gas vacuoles**) are sometimes to be recognized in other kinds of Amoeba but they are exceedingly rare, if they occur at all, in *Amoeba proteus*.

The ectoplasm differs from the endoplasm in that it is less fluid, more highly refracting, without enclosed granules and of a clear glassy appearance. It is usually very thin and its outer surface normally covers itself with a thin coating of slime which is of importance in the creature's movements.

The nucleus is a dense, fairly solid, highly refracting body—colourless like the rest of the protoplasm and showing a characteristic uniformly mottled appearance. This mottled appearance is due to its being composed of two different substances the one denser and more highly refracting than the other. The former, consisting of a complicated mixture of proteins which are specially rich in Phosphorus, is characterized by a special affinity for certain stains or dyes. When the dead Amoeba is subjected to the action of these stains this portion of the nuclear material becomes stained specially deeply and the substance of which it is composed has consequently been given the name **chromatin** to distinguish it from the less deeply staining **achromatin**.

Continued observation of living specimens of *Amoeba* brings out many other points besides those already mentioned. The living Amoeba shows almost constant movement—movement of a kind so characteristic that although it occurs in various other animals it is known technically as amoeboid movement. This movement consists in the pushing out of portions of the body surface into projections known as **pseudopodia**—usually with blunt rounded ends.¹ The pseudopodia are pushed out from any part of the surface indifferently and their tips end freely, never fusing with one another.

If a single pseudopodium is carefully watched during its protrusion it is seen that its centre is occupied by an outwardly rushing stream of endoplasm. The ectoplasm which bounds it may often be observed not to reach quite to the tip—the extending tip being formed of granular endoplasm. Such endoplasm, however, exposed on the surface of the pseudopodium to contact with the water, is seen gradually to lose its granular character and take on the appearance of ectoplasm. In some kinds of *Amoeba* other than *Amoeba proteus* what are termed **eruptive lobopods** are formed. When an eruptive lobopod is protruded what

¹ Pseudopodia with blunt rounded ends are sometimes called lobopods to distinguish them from other types of pseudopodia such as will be mentioned later.

happens is that the ectoplasm ruptures and a quantity of endoplasm wells out at the perforation. This extrusion forms then an extension of the body of the Amoeba composed at first entirely of endoplasm (Fig. 2, A). Very soon however the superficial layer loses its granularity, becomes highly refracting and assumes the characters of typical ectoplasm. Portions of the original ectoplasm covered in and sheltered from contact with the water by the newly formed lobopod gradually fade away, losing the characters of ectoplasm and taking on those of endoplasm (Fig. 2, B). We are taught by such observations as these that ectoplasm and endoplasm are not fundamentally distinct substances, and that the characters which normally differentiate ectoplasm from endoplasm are merely temporary modifications taken on by the surface layer of the cytoplasm as a reaction to its contact with the surrounding water.

The pseudopodia are not permanent organs : they are pushed out

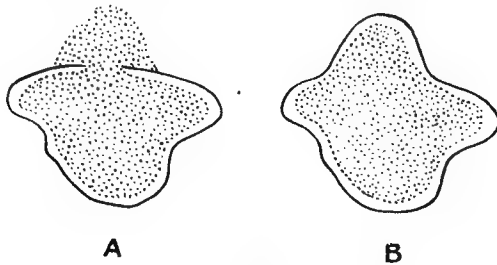

FIG. 2.

Illustrating the formation of an eruptive lobopod.

as has been described and they may be drawn in, apparently by the shrinkage of their containing layer of ectoplasm. Although they may be pushed out from any part of the surface indifferently, their formation is as a rule at any one moment of time taking place more actively on one particular portion of the surface. The result is that, as the pseudopodia are pushed out more actively in one particular direction, the Amoeba undergoes change of position towards that direction, pseudopodia pointing in other directions shrinking in and disappearing. There are few sights more impressive to the eye that has a brain behind it than that of a large healthy Amoeba with its protoplasm actively streaming out into its pseudopodia, carrying on that old world type of movement, just as it in all probability took place at the dawn of evolution when living substance first began to move.

Although the Amoeba can push out its pseudopodia when floating freely suspended in the water it can creep along as a whole only upon a

solid surface. Further the coating of slime over the surface of the ectoplasm is apparently also essential to creeping movement. The actual rate of creeping appears to be anything up to about one to three millimetres in an hour.

Besides the ordinary fluid vacuoles which may be present in the endoplasm there exists a **contractile vacuole**. This makes its appearance—usually towards the part of the Amoeba which is hindmost when it moves—in the form of a small droplet of water which slowly and regularly increases in size till it is about as large as the nucleus. When it reaches its limit of size it is suddenly obliterated and if the water surrounding the Amoeba contains solid particles, *e.g.* of indian ink or carmine, these can be seen to be pushed aside, the water of the contractile vacuole passing out to the exterior. Presently a new droplet appears in the position of the vacuole, and this increases and collapses just as before. There goes on in fact a regular rhythm of expansion (**diastole**) and contraction (**systole**) the complete cycle occupying commonly from 5 to 8 minutes. The contractile vacuole is constantly pumping water from the protoplasm of the Amoeba to the exterior—water no doubt being absorbed by the general surface of the creature to make good the amount withdrawn. The living protoplasm is thus constantly being flushed with watery fluid by the activities of the contractile vacuole. The purpose of this seems to be mainly in connexion with two great functions of living matter—**respiration** or breathing and **excretion** or the getting rid of waste products. The incoming water brings with it supplies of the Oxygen which is essential to all living activity: the outgoing water carries with it the Carbon dioxide and other more complicated waste substances which are constantly being produced by this living activity.

It is said that the fluid from the contractile vacuole exhibits a curious property outside the body of the Amoeba—that of causing bacteria living in the water to **agglutinate** or become clumped together in solid masses, and so rendering them more easily taken in by the Amoeba as food.

The actual process of feeding is difficult to observe for it takes place preferably in the dark or in very faint light. The Amoeba feeds on solid particles of suitable food material such as small plant or animal cells. If the Amoeba comes up to one of these it seems as it were to flow round it (Fig. 3, *f*) sending out extensions of its protoplasm on all sides of the food particle which meet beyond it and enclose it with a small quantity of the surrounding water. The food particle comes thus to be shut up in a drop of water—the **food-vacuole** (Fig. 3, *f.v*)—within the endoplasm of the Amoeba.

Sometimes the food-organism is in the form of a long slender thread as is the case with so many of the simpler water weeds or algae. In such a case the Amoeba goes to work in rather a different fashion. Surrounding the filament it spreads along it and gradually draws it inwards so that eventually the filament is coiled up into a mass within the endoplasm.

Following on the process of **ingestion** in which it is taken into the body of the Amoeba the food particle undergoes a series of changes. If an actively moving organism its movements are seen to continue for some little time within the food-vacuole but presently they cease and the food-

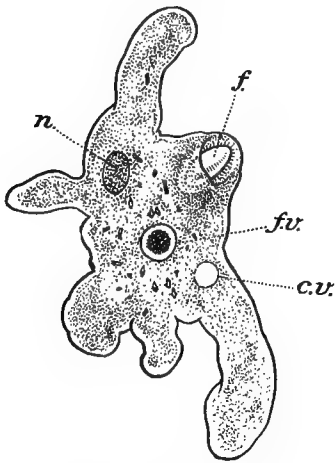

FIG. 3.

Ingestion of a small animal by an Amoeba. *c.v.*, Contractile vacuole; *f*, food-organism in process of ingestion; *f.v.*, food-vacuole; *n.*, nucleus.

organism is evidently dead. Chemical testing at this stage shows that the watery fluid within the food-vacuole has become strongly acid. Acid has been formed, or **secreted** as the technical expression is, by the surrounding protoplasm of the Amoeba and poured into the food-vacuole. This acid secretion has apparently for its sole function the killing of the food-organism.

There now ensues the process of **digestion**. The green vegetable cell, as we assume the food-organism to be, gradually changes colour becoming dark green, yellow, yellowish red, brown, brownish red. The cellulose wall breaks down and the whole body of the food-organism disintegrates. The protoplasm of the Amoeba has secreted into the food-vacuole

digestive ferments. **Ferments** or **enzymes** are a remarkable class of substances produced by the living activity of animals or plants, which have the mysterious power ("catalytic" power) of inducing or hurrying up specific chemical changes in substances with which they are in contact. In this particular case the main ferment at work is one which causes the dead protoplasm of the food-organism to break up into simpler chemical compounds which the living substance of the Amoeba is able to absorb and make use of in building up new protoplasm of its own, for it appears to be the case that living protoplasm is never able simply to add to itself living protoplasm directly. The latter must be killed and digested, *i.e.* broken down into simpler substances, before it can be made

use of for building up additional protoplasm for the animal that feeds on it. An important detail to notice in the case of the Amoeba is that the fluid in the food-vacuole when this digestive ferment is at work is found to have lost its acid reaction and to have become distinctly alkaline. In the fact of its working in an alkaline medium the ferment resembles what is known in the higher animals as the **tryptic** type of digestive ferment. Each type of ferment has an absolutely restricted and specific type of action and it is believed that the breaking up of the cellulose wall of the vegetable cell is brought about by a second ferment quite different from that which digests the protoplasm.

As the process of digestion goes on the contents of the food-vacuole become completely disintegrated. All that can be made use of for building up new protoplasm is absorbed by the living protoplasm of the Amoeba, and there eventually remain in the vacuole only particles of useless debris—**faecal** matter. Finally the food-vacuole is seen gradually to approach the surface: it touches the surface film of protoplasm and bursts, and the Amoeba proceeds on its way leaving the little heap of faecal matter behind.

Before leaving the process of digestion it may be well to accentuate the fact that the killing of the food-organism is an essential preliminary to the process, for it is a remarkable fact that living protoplasm is completely immune to the action of the digestive ferment. Thus the protoplasmic walls of the food-vacuole though in immediate contact with the digestive ferments are completely unaffected by them, because they are alive.

As the Amoeba feeds and keeps on building up new protoplasm it naturally increases in bulk: it **grows**. Now it is fairly clear that, the organization of Amoeba being what it is, prolonged growth would necessarily lead to an impossible state of affairs, for the Amoeba must have a sufficiently great area of surface by means of which it can feed and absorb water and oxygen and get rid of waste products. But the more it increases in bulk the smaller in proportion would become its surface, until soon it would be quite inadequate for the animal's needs. Again, the fluid cytoplasm of the Amoeba would obviously lose all cohesion and be quite unable to retain its form were it to be otherwise than of very small dimensions. Consequently there has to exist in nature some corrective to the process of growth which will ensure the Amoeba's not reaching too large a size for efficiency. This corrective is found in the process known as **fission**, by which the body of the Amoeba becomes nipped across so as to form two individuals.

The process is inaugurated by the nucleus dividing into two and

this process is of the complicated kind known as **mitosis** or karyokinesis, characterized above all by the chromatin becoming condensed in the region of the equator of the nucleus into a definite number of rounded or rod-shaped pieces called **chromosomes**, each of which divides into two halves, these being distributed to the two daughter nuclei. The details of the process are obscure in *Amoeba* and its allies and therefore their description will be held over until we are dealing with a group of animals in which they are more distinct (Chap. V.).

The process of mitosis having been completed (Fig. 4, A-D) the

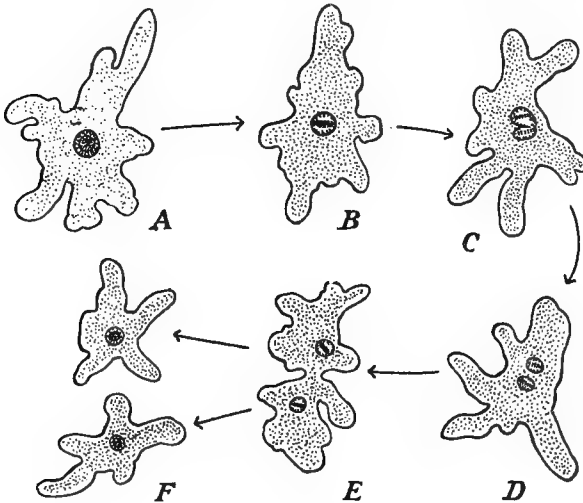

FIG. 4.

Fission of *Amoeba* (nuclear detail after observations by L. A. Carter). A, Amoeba before the onset of fission; B, most of the chromatin has become concentrated in chromosomes about the equator of the nucleus; C, each chromosome has divided into two, the two sets of daughter chromosomes are moving apart and the boundary of the nucleus is becoming indented between them; D, the nucleus has become completely divided into two daughter nuclei; E, the two nuclei have moved apart and the cytoplasmic body of the Amoeba is undergoing constriction; F, the process has been completed.

Amoeba takes on an elongated form and its cytoplasm becomes constricted across between the two daughter nuclei (Fig. 4, E). As the constriction deepens the isthmus connecting the two masses of cytoplasm becomes narrower and narrower until finally it snaps across, leaving in place of the original *Amoeba* two *Amoebae* of half its size which gradually move apart and lead their own lives (Fig. 4, F).

In this process of fission which serves in *Amoeba* as a corrective to the process of growth we see a good example of the simplest of all types of **reproduction**, in which increase in the number of individuals is brought

about by a parent individual simply resolving itself into two daughter individuals. This simple process of fission is not the only method of reproduction occurring in *Amoeba proteus*. During the winter season when conditions are unfavourable to the continued activity of the Amoebae they hibernate in the seclusion of a protective **cyst** which they form round themselves and during this period of seclusion they reproduce by a method other than that of simple fission.

At the commencement of this period of encystment the Amoeba is seen to become sluggish in its movements and there accumulates over its surface a thick mass of sticky slime mixed with particles of debris—derived partly from the mud outside, partly from solid faecal matter which the Amoeba extrudes completely at this time. The Amoeba assumes a spherical shape and now secretes all over its surface a tough membrane, usually in two distinct layers with a space between. The three layers indicated—the outer slimy and the two inner membranous layers—constitute the protective cyst in which the Amoeba hibernates.

During the period of encystment the nucleus of the Amoeba undergoes mitosis repeatedly until there is a large number of nuclei—commonly from 75 to 100—and the cytoplasm now breaks up into as many pieces, each containing a nucleus. When conditions become favourable, in the early spring, these issue from the cyst as so many small Amoebae, which proceed to lead their normal life and gradually grow to the full size.

What has been said up till now regarding *Amoeba* has been ascertained, by the method of simple **observation**, but it is possible to add considerably to the knowledge so obtained by making use of the method of **experiment**, *i.e.* by introducing some sudden change into the conditions under which the Amoeba is living and ascertaining how it reacts to the particular change of conditions. Various kinds of change may be made use of to serve as a stimulus to the Amoeba—mechanical, chemical, thermal, electrical—and so on. Of such it may be said in general that the Amoeba reacts to a really *strong* stimulus of almost any kind by retracting its pseudopodia and assuming a spherical shape. On the other hand a comparatively slight stimulus produces a reaction more or less specific to the particular type of stimulus. As a mechanical stimulus for example one may touch with a needle the edge of the Amoeba on the side towards which it is creeping: the Amoeba reacts by turning aside—altering the direction of its movement. Chemical change has been tried on a kind of Amoeba known as *Amoeba limax*, characterized by the possession of a single blunt pseudopodium (Fig. 5, A). In this case making the water slightly alkaline was found to be followed by a change in the whole form of the Amoeba which protruded a number of slender tapering

pseudopodia and took on the appearance of what was supposed to be a quite distinct kind of Amoeba known as *Amoeba radiosa* (Fig. 5, B). A slight rise in temperature is reacted to by increased activity of movement but if the rise be continued up to about 30° C. the increased activity is only temporary and is followed by gradual slowing and eventually by death. Exposure to a temperature of 35° C. is followed rapidly by retraction of the pseudopodia and death. Reduction of temperature below the normal is followed by a slowing of the movement without any other apparent ill effects. Exposure to intense light is followed by rounding off and death. Even ordinary daylight produces a reaction. If the Amoeba is in a shadow it has been observed to draw back when

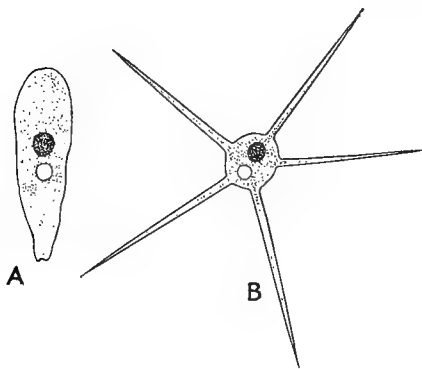

FIG. 5.

Reaction of *Amoeba limax* to slight alkalinity of water. A, before adding alkali (creeping type); B, after adding alkali (floating type).

it comes to the edge of the shadow, and it is only in comparative darkness as a rule that such events of normal life as feeding or fission take place. The Amoeba shows interesting reactions to electrical conditions. If a very weak current of electricity is caused to pass through water containing individuals of *Amoeba limax* they are observed to creep towards the cathode or negative pole. Sudden reversal of the current is

followed by reversal of the movement of the Amoebae.¹ Exposure to the emanations of Radium is soon followed by rounding off and death.

An instructive experiment which has been made on Amoeba is the division of the living creature into two portions (**merotomy**). When the experiment is successfully carried out it is usually found that the smooth slippery nucleus slips to one side of the cutting edge and passes completely into one of the two portions of the cytoplasm. The result of the experiment then is the production of two Amoebas which may be almost exactly alike as regards size but which differ in this respect that one

¹ Such movements of an organism or of parts of an organism in response to specific stimuli are designated in technical language by special names ending in -tropism or -taxis. Thus *chemiotaxis* (chemical stimulus), *phototaxis* or *heliotropism* (light), *galvanotaxis* (electrical), etc.

consists entirely of cytoplasm while the other possesses in addition a nucleus. Subsequent observation shows that this difference as regards the possession of a nucleus is accompanied by striking differences in behaviour. The nucleated portion continues its existence as a perfectly normal Amoeba, performing all the vital functions—moving, feeding, growing, exactly as did the original individual.

The non-nucleated portion may for a little seem to behave much as the other. It may push out pseudopodia; if it does not contain the original contractile vacuole it may form a new one. But its movements are sluggish. It is unable to creep along a solid surface and investigation shows this to be correlated with its being no longer able to form the thin coating of slime which normally covers its surface. Again it may ingest food particles but these are no longer properly digested—the power of secreting the digestive ferments is apparently no longer present. Gradually its activities diminish and within a week or ten days they come to an end in death.

GENERAL REMARKS ON AMOEBIA

Having summarized the main facts regarding Amoeba it will now be convenient to glance back at these facts and see what general lessons are to be learned from them.

Firstly we see that the facts fall into two main categories—facts of structure and facts of living activity or function. These two categories constitute the two primary subdivisions of zoological science: **Anatomy**, which deals with all details of structure, form, etc.—such details in fact as can be gathered from the investigation of the dead body—and **Physiology**, which concerns itself with all the various manifestations of life.

Secondly *Amoeba* provides us with a good example illustrating the conception of what is known as a **cell**—a conception which permeates all biological science. A cell is “a mass of protoplasm containing a nucleus.” An Amoeba consists of a single cell while the body of any of the larger animals is composed of vast numbers of cells derived by fission repeated over and over again from a single original cell—the egg. The cell does not merely enclose the nucleus but while alive its activities are to a great extent controlled by the nucleus. This again is illustrated by *Amoeba* for we have seen how the removal of the nucleus not only stops some of the striking activities of the Amoeba but after a short time renders life itself impossible.

A further point of importance emerges from the experiment in which the Amoeba is cut in two. Careful and continued scrutiny of the nucleated portion shows that its nucleus undergoes a gradual diminution

in size until at last it bears just about the same proportion to the cytoplasm containing it as it did to the original full amount of cytoplasm before any had been cut away. And this appears to illustrate a general principle namely that in any particular type of cell there is a fairly definite normal proportion in size between nucleus and cytoplasm, and it is suspected that the disturbance of this proportion may play an important part in the production of certain abnormal conditions met with in disease.

We have seen that the movements of the Amoeba are of a characteristic type. Now it is an interesting fact that these movements can be produced artificially in non-living substance. It is possible by using special methods to produce extremely fine froth or foam composed of a mixture of slightly rancid oil and watery fluid. Minute droplets of this foam placed in water are seen when watched under the microscope to change their form, "pseudopodia" being pushed out from their surface and the whole droplet changing its position just as a live Amoeba would do. But in the case of these oil droplets the movement is capable of physical explanation. Any drop of fluid immersed in another kind of fluid with which it does not mix is subject to the laws of "surface tension." Its surface layer acts as if it were an elastic membrane always tending to shrink in area: the tendency of the drop therefore is to assume a spherical form—the form in which the proportion of surface to bulk is at its minimum. If a portion of the surface begins to bulge out and form a projecting "pseudopodium" the meaning of the phenomenon is that that particular part has had its surface tension reduced so that it gives way to the internal pressure due to the tension of the surface layer as a whole.

Now there is no reason to doubt that the pushing out of the pseudopodium of a living Amoeba is due similarly to weakening of the surface tension over that particular portion of the Amoeba's surface. But it must be borne in mind that this explanation of pseudopodium-formation while quite satisfactory so far as it goes is not by any means a complete explanation, for when we ask the question why should the surface tension in some particular region undergo the diminution which leads to the pushing out of a pseudopodium the only answer is that it is due to some process involved in the living activity of the cytoplasm regarding the nature of which we are quite ignorant.

It is not merely the extrusion of pseudopodia which can be produced in non-living substance: the same applies to the gradual ingestion of a slender filament. If a drop of chloroform is brought into contact with a fine filament of glass-wool coated with shellac it is found that the surface tension of the chloroform gradually draws the glass filament into the

interior of the drop of chloroform forcing it into a coil. There is again no reason to doubt that the ingestion of the vegetable filament by the Amoeba is brought about by the action of surface tension.

The Amoeba, as we have seen, feeds and the products of digestion are absorbed and built up into new living protoplasm. Although normally this results in increase of bulk, growth, it does not do so necessarily. An Amoeba or other animal may go on absorbing food material and yet show no increase in size. This indicates that in the living body there goes on not merely a process of building up new protoplasm but also a breaking down of the existing protoplasm. While on the one hand relatively simpler substances derived from the food are constantly being built up into the enormously complex living protoplasm, at the same time the living protoplasm is undergoing a process of breaking down into less complicated non-living substances. The sum total of these processes constitutes what is known technically as **metabolism**. It is further customary to distinguish the building up processes by the name anabolism and the breaking down processes by the name catabolism. These names are of practical convenience but the student should guard from the commencement against the fallacy that attaching a long technical name to a phenomenon necessarily implies any increase in our knowledge concerning it. As a matter of fact very little is known regarding the intimate nature of metabolic processes. One of their characteristic features is their accompaniment by oxidation. The catabolic processes in fact are as it were accompanied by a slow process of combustion. In many of the larger animals with active metabolism the temperature of the body is actually raised considerably above that of the surroundings by this process of combustion. In a tiny creature like Amoeba this is not perceptible, but, no doubt, could we test its temperature by a sufficiently delicate and reliable method, we should find that even it is slightly warmed up by its oxidation processes.

In the living creature at any one particular time there may be complete metabolic balance—the anabolic and the catabolic processes simply counteracting one another—or one of them or the other may preponderate. If anabolism preponderates the creature increases in bulk, if catabolism preponderates diminution of the living substance takes place. In the latter event there may be no visible shrinkage in bulk, for the diminution of living substance may be made up for by the accumulation within the body of bulky non-living substance formed by its breaking down.

An important detail in connexion with the metabolism of *Amoeba* has to do with the nature of the food. This must contain ready-made proteins for the Amoeba is quite unable to build up its protein out of

chemically simpler materials. And here we see one of the most striking differences between the animal and the vegetable kingdoms. The typical plant by the aid of its green colouring matter or chlorophyll is able during exposure to daylight to take comparatively simple materials such as carbon dioxide and nitrates and build them up into more and more complex substances culminating in living protoplasm. The typical animal is quite unable to do this : it must have its proteins ready provided for it ; and it will be realized from this that the animal world as it exists to-day is dependent for its continued existence upon the vegetable world—for upon the latter depends ultimately the supply of protein food material.

We have given a description of a particular kind or species of Amoeba—*Amoeba proteus*—but it will have been gathered from such names as *Amoeba limax* and *Amoeba radiosa* that there are other kinds. It is customary in scientific writing when referring to any particular kind of animal to give it two names—to use what is called the **binomial** system of nomenclature developed by the great Swedish naturalist Linnaeus (1707–1778). We may conveniently illustrate this system by the case of animals larger and more familiar than Amoeba such as for example the various “ cats ” large and small which exist as wild animals. Each of the kinds or **species**—such as the lion, the tiger, the leopard, the jaguar, the puma, the tiger-cat, the lynx, the wild cat—is given a special or specific name, while they are also given a common name, indicating that the several species belong to a group corresponding to the idea conveyed by the English word Cat when used as above in the broad sense. Such a group, of higher order than a species, is termed a **genus**, and is given a special generic name. In the particular case under discussion the generic name is *Felis*, while of the various species mentioned the lion is known as *Felis leo*, the tiger as *F. tigris*, the leopard as *F. pardus*, the jaguar as *F. onça*, the puma as *F. concolor*, the tiger-cat as *F. pardalis*, the lynx as *F. lynx*, the wild cat as *F. catus*, and so on with other species. It is usual to print such scientific names, which are regarded as Latin substantive and adjective, in italics, and when it is quite clear what is meant the generic name is commonly contracted down to its initial letter. The use of such names is not due to mere pedantry : it is rendered necessary for purposes of precision by the fact that popular names are liable to give rise to confusion. Thus such a name as “ Crow ” is applied in different English-speaking regions of the world to totally different kinds of birds.

Of the Amoebae a number of species are recognized, differing from

A. proteus in such characters as size, shape of pseudopodia, and so on, but the only ones that call for special mention are a group of species which have taken to a parasitic existence and are therefore of practical interest to medical men. Of these parasitic Amoebae—which are usually now set apart as a separate genus with the name *Entamoeba*—there are three species which are well-known parasites of man. Two of these appear to do no harm, playing the part of scavengers and devouring bacteria, etc.—*E. gingivalis*, a small Amoeba, commonly found creeping about in the mouth, especially in and about teeth which are not kept properly cleansed, and *E. coli* (Fig. 6, B), a sluggishly moving Amoeba common in the large intestine. The third species—*E. histolytica* (Fig. 6, A)—burrows in the wall of the large intestine, devouring and destroying its cells and causing ulceration. In the great majority of cases this ulceration is not sufficient to produce obvious disease, but in other cases where it goes farther it causes dysentery—“Amoebic” dysentery as it is termed to distinguish it from “bacillary” dysentery caused by bacteria—or, it may be, localized abscesses in the liver or, more rarely, in the lung or brain.

E. histolytica is a smallish Amoeba, measuring as a rule when rounded about $20\ \mu$ to $30\ \mu$ in diameter.¹ Under normal conditions in the body it has a limax-like form, without clear distinction of ectoplasm from endoplasm, and glides along with great rapidity. If examined on a glass slide outside the body at ordinary room temperature it, on the other hand, remains in one spot, pushing out broad flat pseudopodia of clear transparent ectoplasm (Fig. 6, A, 1). The endoplasm of *E. histolytica* is finely granular in appearance and usually contains ingested food material—remains of cells of the intestinal wall and, more especially, red blood-corpuscles (Fig. 6, A, 1, e). The presence of these latter is a reliable diagnostic feature distinguishing *E. histolytica* from the harmless *E. coli* which feeds mainly on bacteria.

As was the case with *A. proteus*, reproduction is carried out normally by a simple process of fission. From time to time, however, the Amoebae leave the intestinal wall and make their way into the cavity of the intestine as a preliminary to encystment. They are now much smaller in size: their nucleus is relatively larger: the endoplasm is full of vacuoles and is without blood-corpuscles. As the time of encystment approaches, reserve food material is stored up in the form of one or more

¹ The unit of length commonly used in biological science for small dimensions is the one-thousandth part of a millimetre, usually designated by the Greek letter μ . A convenient rough gauge always at hand is afforded by the red blood-corpuscle of man which is a circular disc measuring normally from $7\ \mu$ to $8\ \mu$ in diameter.

vacuoles containing the starchlike substance **glycogen** (Fig. 6, A, 2, *g*) and rodlike masses of chromatin-like material (Fig. 6, A, 2, *ch*). The Amoeba now rounds itself off and secretes over its surface a thin membranous protective cyst. The cyst is most frequently between $11\ \mu$ and $14\ \mu$ in diameter, but there is a wide range of variation in size, for races

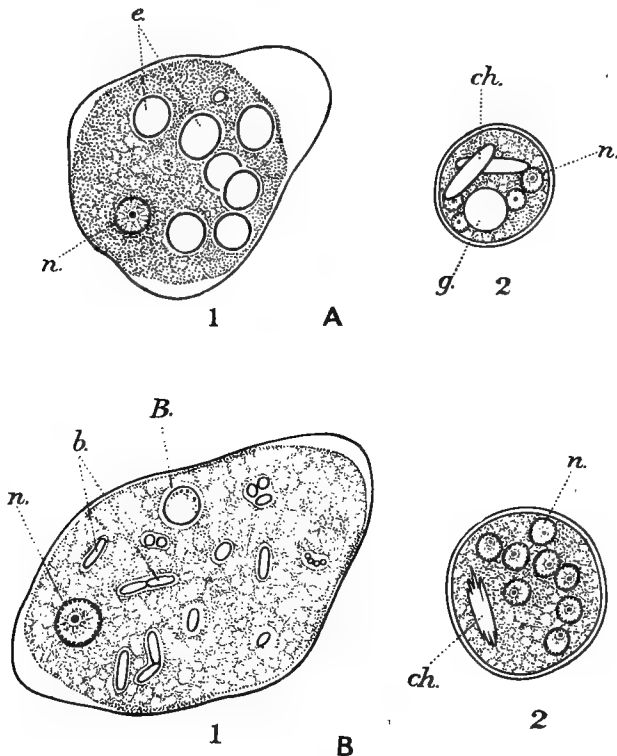

FIG. 6.

Amoebae from the intestine of man. A, *Entamoeba histolytica*; B, *E. coli*.

(From drawings by M. W. Jepps.)

B, ingested vegetable cell (*Blastocystis*); *b*, ingested bacteria; *ch*, chromatin bodies; *e*, ingested blood-corpuscles; *g*, glycogen vacuole; *n*, nucleus.

of the parasite have been found in which the diameter is as small as $5\ \mu$ and others in which it is as large as $20\ \mu$.¹

¹ In the case of *E. coli* there exist similar differences so that, although there is a tendency for the cysts of *E. coli* to be larger than those of *E. histolytica*, mere size does not afford a trustworthy criterion for distinguishing between the cysts of the two species.

The encysted phase is essentially a resting phase in the life-history during which the living activities are slowed down. Apart from the gradual using up of the reserve food-material—first the glycogen and then the chromatoid substance—the only conspicuous activity is division of the nucleus which takes place normally twice in succession so that the encysted amoeba contains 4 nuclei (Fig. 6, A, 2, *n*).¹

The encysted stage serves for the infection of new individuals. The cysts pass away to the exterior. Under conditions of drought the encysted Amoebae very soon die but under cool and moist conditions they retain their vitality for some time, it may be as long as five weeks although as a rule not longer than a fortnight. If swallowed, *e.g.* in drinking water, the cyst is dissolved under the influence of the digestive ferments and the contents set free in the intestine to start a new infection. It does not appear to be definitely established whether the division into four separate uni-nucleate Amoebae takes place before or after being set free from the cyst.

E. histolytica appears to be widely distributed over the earth's surface as a parasite of man, although its presence is more conspicuous in warm climates. When it gains a footing in the human body it is apt to persist for prolonged periods, probably throughout life, unless special measures are taken to get rid of it. And a point of great practical importance is the fact that only a comparatively small proportion of infected individuals—perhaps under ten per cent—betray their infection by recognizable symptoms of disease: for the others, while not recognizable as invalids, yet serve all the while as animated reservoirs or **carriers** of the parasite, disseminating it in the encysted phase and in this way spreading infection.

Apart from the causation of disease it would appear that Amoebae are of practical importance to man in relation to agriculture. Many green plants are dependent upon the existence in the soil of bacteria which prepare for them a supply of nitrates from which they can obtain their supplies of nitrogen. Now these nitrifying bacteria have active enemies in the form of amoeboid and allied creatures which creep about in the soil. Sometimes a rich soil becomes "sick" *i.e.* its fertility becomes greatly diminished although chemical analysis fails to show any evidence of diminished richness. By baking such "sick" soil for a few hours, or by treating it with chloroform vapour it has been found that a marvellous recovery can be induced and it has been suggested that the

¹ It should be noted for purposes of diagnosis that in the case of the harmless *E. coli* an additional division normally takes place so that there are *eight* nuclei within the cyst.

“sickness” is caused by an abnormal increase in number of the amoeboid and other organisms which prey upon the nitrifying bacteria, and that the “cure” is brought about by the killing off in turn of these organisms so that the more highly resistant bacteria are able to multiply till they again reach their normal numbers.

PROTOZOA

SCHEME OF CLASSIFICATION

I. SARCODINA.

A. Rhizopoda.

1, Amoebae. 2, Foraminifera.

B. Actinopoda.

3, Heliozoa. 4, Radiolaria.

II. FLAGELLATA.

III. SPOROZOA.

A. Telosporidia.

1, Gregarinida. 2, Coccidia. 3, Haemosporidia.

B. Neosporidia.

4, Cnidosporidia. 5, Sarcosporidia. 6, Haplosporidia.

IV. CILIATA.

1, Holotricha. 2, Heterotricha. 3, Hypotricha. 4, Peritricha.

Appendix to Ciliata—ACINETARIA.

I. SARCODINA

Amoeba is a characteristic example of the main sub-division or **phylum** of the Animal Kingdom called Protozoa because its members come first in order of simplicity of obvious structure. This phylum includes a vast number of different genera which when compared together and classified are found to fall naturally into certain sub-groups the more important of which are mentioned in the scheme given above. Amoeba itself is placed with a number of its allies in the small group AMOEBAEA, characterized above all by the blunt pseudopodia (lobopods) which do not show any tendency to fuse with one another. Two interesting examples of this group are the genera *Arcella* and *Diffugia*, both common in fresh-water pools. These, unlike *Amoeba* which is naked, shelter their bodies within a portable house or shell, only the pseudopodia projecting beyond its opening. In *Arcella* the shell is composed entirely of

secreted material, somewhat hornlike in appearance, shaped like a concavo-convex lens, and possessing a circular opening in the middle of the concave side. In the case of *Diffugia* the shell or house is on the other hand built up of foreign particles, it may be small grains of sand, or particles of the skeletons of freshwater animals, fitted closely together over its surface and held together by a cement secreted by the animal's protoplasm. An important physiological peculiarity of *Arcella* is that it habitually produces in its protoplasm gas-vacuoles¹ which counteract the weight of the shell. It is said that when the *Arcella* is capsized on to its convex side it is able to right itself by active formation of gas vacuoles which buoy it up and enable it to recover its normal position.

POLYSTOMELLA

Of the FORAMINIFERA it will be convenient to study in the first instance a special example namely *Polystomella* which can be easily investigated in the laboratory. If handfuls of seaweed are plucked from rocks near low-water mark and washed to and fro in a dish of clean sea-water it will be found that numerous grains of "sand" are washed out of the seaweed and sink to the bottom of the vessel. If now the vessel be left undisturbed it will be found after a few hours that some of the apparent grains of sand have crept up the sides of the vessel and are attached to it. They are really living Foraminifera and amongst them one can often recognize *Polystomella* by the characteristic brown colour of its cytoplasm. Examined with a low power of the microscope the *Polystomella* is seen (Fig. 7) to have its body coiled in a flat spiral. It is supported by a shell or **skeleton** composed mainly of calcium carbonate, and divided up into successive chambers which increase in size from the centre outwards—each chamber fitting spoonwise over the chamber on its inner side. Each chamber is filled by a mass of protoplasm the form of which is readily seen on dissolving away the opaque calcium carbonate by means of acid. A characteristic detail which enables one to distinguish *Polystomella* from other and somewhat similar Foraminifera is that the edge of each protoplasmic mass, except those nearest the centre, projects backwards in a row of peglike extensions over its predecessor (Fig. 8, 1 and 7, *p*). The successive masses of protoplasm are not completely isolated from one another: each mass is continuous with its two neighbours by one or more bridges of protoplasm towards its central end. The outer wall of each chamber is perforated by numerous minute pores or

¹ The gas has generally been regarded as carbon dioxide but more recent investigations (Bles) suggest that it is oxygen.

foramina and through these the protoplasm is continued outwards to form a thin layer of **external protoplasm** which ensheathes the whole shell. The shell is therefore not an external shell like that of a snail but an **internal skeleton** completely embedded in living substance. The external protoplasm extends outwards—when the creature is active—into pseudo-

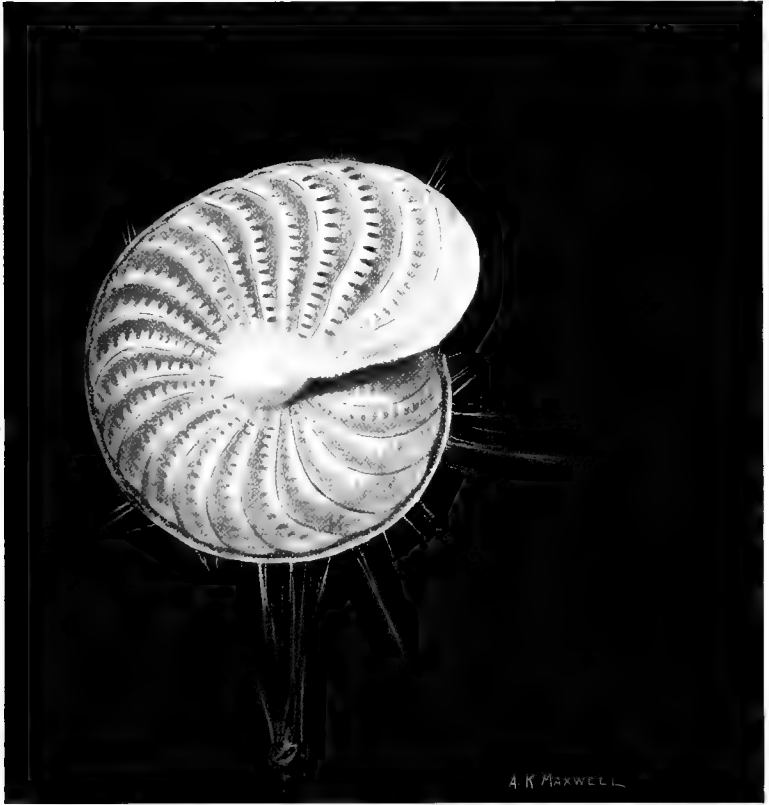

FIG. 7.

Polystomella, alive. Certain of the pseudopodia towards the lower side of the figure are flowing round a particle of food.

podia (Fig. 7) which are however in appearance totally unlike those of *Amoeba*. They are very long slender threads of protoplasm which show a marked tendency to fuse in places with their neighbours. With a high magnification it may be seen that there is a constant slow circulation in the extruded pseudopodium—the cytoplasm streaming outwards along

one side and inwards along the other. While the *Polystomella* can creep slowly along by means of its pseudopodia the most conspicuous function of these organs is in feeding. When a small food organism comes in contact with a pseudopodium it is paralysed and killed, apparently by the action of some virulent poison secreted by the protoplasm of the *Polystomella*. Neighbouring pseudopodia move towards the food-particle and by active streaming movements protoplasm accumulates round the food-particle so that the latter is completely enclosed in a mass of protoplasm at it may be quite a considerable distance outside the main body of the *Polystomella*. Within this the process of digestion is completed and the products of digestion are carried back by the protoplasmic stream into the body of the *Polystomella*.

While any specimen of *Polystomella* shows the general characteristics mentioned so far, the close scrutiny of a large number of individuals after removing the shell by treatment with dilute acid and staining the protoplasm brings out the fact that the individuals belong to two distinct types—in technical language that the species is **dimorphic**. The most conspicuous difference between the two is seen in the size of the **initial chamber** of the shell, *i.e.* the smallest, first formed, chamber right in the centre of the spiral. In the more frequent type (Fig. 8, 1) this (*M*) is spherical in shape and measures from 60 μ to 100 μ in diameter. This is known as the **megalospheric** type. In the other or **microspheric** type (Fig. 8, 7) the initial chamber and its contained mass of protoplasm (*m*) is much smaller—only about 10 μ in diameter. Another characteristic difference is seen in the second chamber which in the megalospheric individual is long, curved and somewhat horn-shaped, while in the microspheric it is somewhat oval. Finally the nuclear arrangements are very different. In the megalospheric individual there is a large “principal nucleus” (*n*) situated just about the middle of the whole mass of protoplasm—*i.e.* if the spiral were straightened out it would have roughly equal amounts of protoplasm on its two sides. Nuclear material is not confined to the principal nucleus for scattered irregularly through the cytoplasm are small particles and irregular shreds of chromatin. Such particles of chromatin occurring outside the limits of a definite nucleus are termed **chromidia**. In the microspheric individual there are also chromidia present (Fig. 8, 7, *chr*), but instead of a single principal nucleus there are numerous small round nuclei which multiply as the *Polystomella* increases in size.

Some of the most striking features of the *Polystomella* have to do with its life-history, and its dimorphism is found to be associated with two different types of reproductive process which occur in that life-history.

If we follow out the fate of the microspheric individual (Fig. 8, 7) we find that it reproduces by a process of multiple fission or **schizogony**

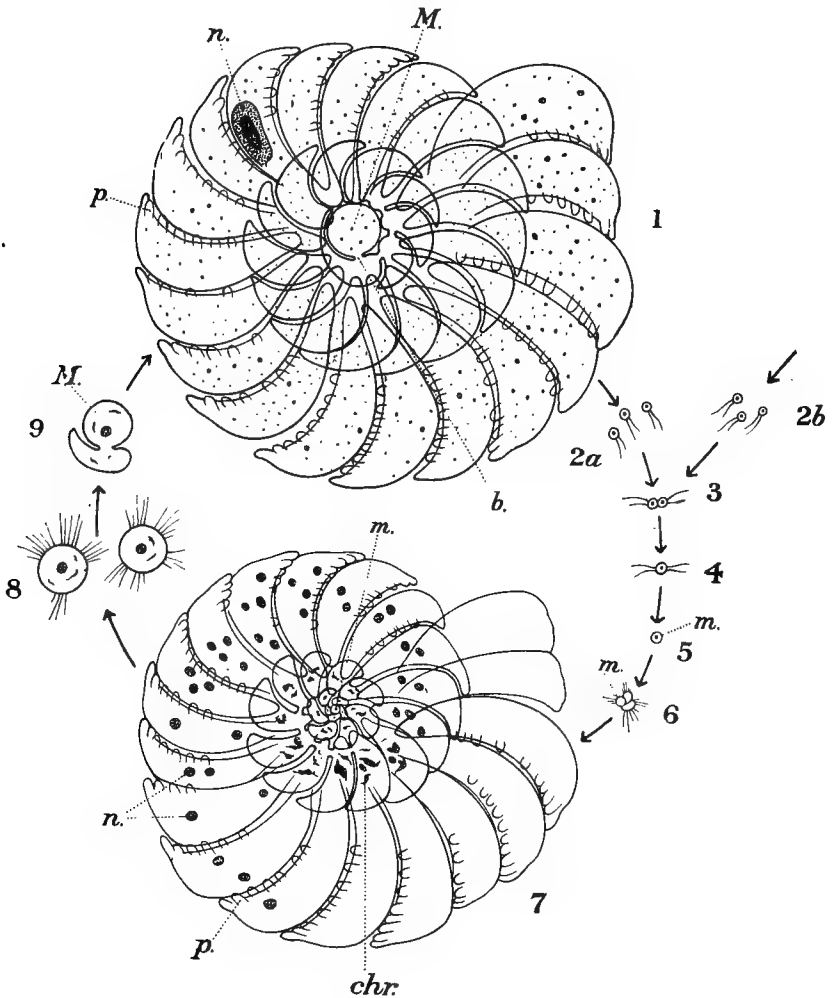

FIG. 8.

Life-history of *Polystomella* according to Lister. 1, Megalospheric individual; 2a and 2b, gametes derived from two different megalospheric individuals; 3 and 4, syngamy; 5, zygote (central protoplasm of new microspheric individual); 6, early stage in growth of microspheric individual; 7, microspheric individual; 8 and 9, young megalospheric individuals derived from 7. b, Protoplasmic bridge; chr, chromidia; M, central protoplasm of megalospheric individual; m, central protoplasm of microspheric individual; n, nucleus; p, peg-like projections of cytoplasm.

i.e. division not into two but into a greater number of new individuals. The nuclei become all broken down into chromidia and the protoplasm streams out into the pseudopodia forming a kind of halo round the now empty shell. New round nuclei, probably formed from chromidia, now make their appearance and the protoplasm divides up into rounded masses each containing a nucleus and chromidia (Fig. 8, 8). These secrete over their surface a thin spherical shell and if measured they will be found to be from 60 μ to 100 μ in diameter. Each of these is a young **megalosphere**. It creeps away by means of its pseudopodia. As it increases in size the protoplasm bulges out and forms the characteristic horn-shaped piece that fills the second chamber (Fig. 8, 9). As growth continues other pieces are added on by a similar process and the spiral form of the complete megalospheric individual is built up chamber by chamber. During the process of growth the nucleus—the principal nucleus—migrates onwards passing from chamber to chamber so as to retain throughout its position about the middle of the whole mass of protoplasm.

As the megalospheric individual approaches its reproductive period the principal nucleus disintegrates entirely into chromidia and then the nuclear material concentrates secondarily to form very numerous small round nuclei. The protoplasm becomes segregated round each of these to form a small cell and this undergoes fission twice in succession so that each original cell is represented by four. A curious quivering movement may be seen in the interior of the shell and presently the contents issue forth as a swarm of minute rounded bodies (Fig. 8, 2*a*) each provided with a nucleus and possessing at one end a pair of fine protoplasmic threads or **flagella** by the lashing movements of which the cell swims actively through the water. Each of these flagellate cells simply dies after a short time unless it happens to come across a similar cell (Fig. 8, 2*b*) derived from the breaking up of another megalospheric individual. If this happens the two cells come into contact by their non-flagellate ends (Fig. 8, 3 and 4), the flagella disappear and the two cells gradually undergo complete fusion, not merely the cytoplasm but also the two nuclei becoming indistinguishably fused together (Fig. 8, 5). The single rounded cell so produced is found by measurement to be about 10 μ in diameter. It is a young **microsphere** and gradually grows into a typical microspheric individual.

In this reproduction by the megalospheric individuals we have an example of a sexual process—of what is known technically as **syngamy**. This process consists essentially of the fusion together, and more especially the fusion of the *nuclei*, of two cells termed **gametes** to form a single cell-

individual known as the **zygote**. In this particular instance the biflagellate cells are gametes, the young microsphere is a zygote.

It is customary to use the expression sexual "reproduction" but it should be realized from the beginning that the sexual act—syngamy—is not in itself reproduction: it is in fact the opposite for it involves not an increase but a decrease in the number of cell-individuals. At the same time it is usual to find the sexual act intimately associated with an increase in the number of individuals. In the case of *Polystomella* as in many others this increase takes place immediately before the act of syngamy—in the production of the very numerous gametes.

Looking back upon the life-history of *Polystomella* we see in it a good example of what is called **alternation of generations**—generations of individuals which reproduce sexually (megalospheric) alternating with others (microspheric) in which the reproduction is asexual *i.e.* unaccompanied by syngamy. We also see why it is that the sexual individuals are much more numerous (about 30 to 1) than the asexual—because in their case enormous wastage takes place owing to the act of syngamy depending on the small chance of (1) two individuals in the same neighbourhood producing gametes at the same time and (2) the gamete from the one happening to come into immediate proximity with a gamete from the other.

The Foraminifera in general are characterized especially by (1) the slender thread-like pseudopodia with their tendency to fuse together into a network, (2) the presence of a shell or skeleton which may be composed of horny, or siliceous (=flinty) or, as is much more usual, calcareous secreted material, or may on the other hand be built up of foreign particles such as grains of sand or fragments of the skeletons of other minute animals, and (3) by the differentiation of the individuals into two types—asexual microspheric and sexual megalospheric.

They are typically marine. Many of them creep about on the bottom or on seaweeds, like *Polystomella*; others are **pelagic** (*i.e.* inhabiting the open ocean), forming an important part of what is known as the **plankton** *i.e.* the drifting population of organisms too small or too feeble to travel about by the activity of their own movements. In the pelagic Foraminifera the cytoplasm commonly contains large numbers of vacuoles filled with a watery jelly of slightly less specific gravity than the sea-water, which serves to keep the specific gravity of the creature approximately the same as that of the surrounding water in spite of its heavy skeleton. These pelagic Foraminifera play an important part in the formation of submarine deposits. They exist in countless myriads in the upper layers

of the ocean water in the warmer regions of the globe and consequently there is as it were a continuous rain of their dead bodies down into the depths. Sinking down with extreme slowness their shells are all the while exposed to the solvent action of the sea-water and in the deepest oceans they have been completely dissolved long before the bottom is reached. In waters of more moderate depth however they reach the bottom and, being protected from further solution by the bottom layer of water becoming saturated with calcium carbonate, they accumulate in the form of a

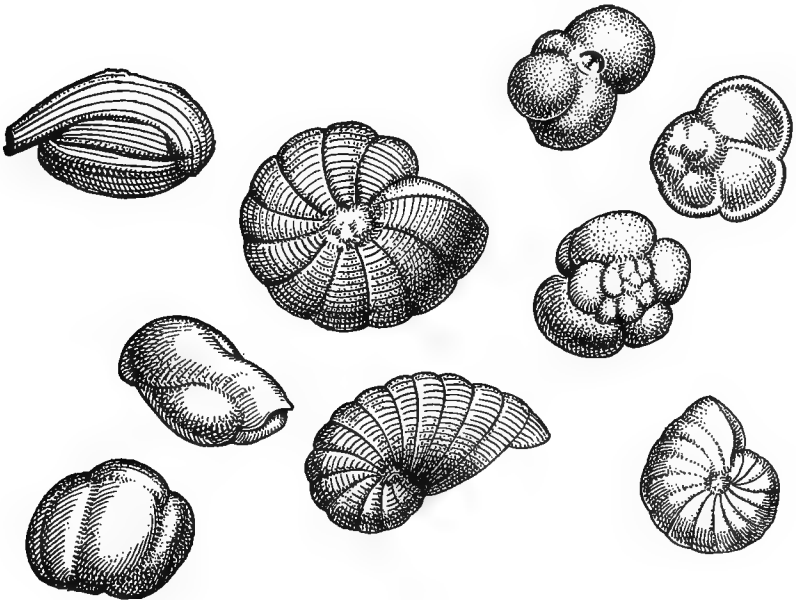

FIG. 9.

Skeletons of Foraminifera.

characteristic greyish foraminiferal ooze—called **Globigerina ooze** from the genus *Globigerina* (see Fig. 9, uppermost figure) which is one of the commonest of these pelagic foraminifera. Foraminiferal ooze has played an important part in the building up of rocks in past geological ages. If a piece of natural chalk be examined by appropriate methods it is found to consist in great part of foraminiferal shells, though these frequently resemble the shells of shallow-water species of the present time rather than pelagic types. Another rock composed of foraminiferal remains is the remarkable Nummulite limestone of Eocene age which stretches in a belt across the Old World from Southern Europe to Japan. This is

composed in great part of coin-shaped discs or **nummulites** ranging up to more than two inches in diameter, each disc being really a huge foraminiferal shell with successive chambers arranged in a spiral, and showing the usual differentiation into microspheric and megalospheric individuals.

There are two groups of organisms—the Mycetozoa and the Proteomyxa—which are not specifically mentioned in the scheme of classification on p. 18 but which must be briefly referred to now.

The MYCETOZOA (Myxomycetes of the botanists) constitute a group which shows such a mixture of animal and vegetable characters that it cannot be said definitely to have taken up either the one line of evolution or the other. Mycetozoa are frequently seen in damp woods forming a beautiful lace-work, often of a bright orange colour, on the surface of fallen and decaying trees. There is no sign of life obvious to the naked eye, except that continued observation shows that the patch of lace-work slowly changes its position. If the network is allowed to spread on to a moist glass slide and examined microscopically it is seen to consist of actively streaming cytoplasm, showing a differentiation into ectoplasm and endoplasm and containing numerous nuclei. Whereas a portion of protoplasm containing a single nucleus is termed a cell, such an undivided mass of protoplasm as this containing a number of nuclei is termed a **syncytium** or plasmodium. It has become advisable to use the former term rather than the latter to avoid confusion owing to the word plasmodium being used also in another sense (see p. 55).

The Mycetozoa are organisms which have given up aquatic existence and become more or less terrestrial, and, correlated with this, they have developed special arrangements for protection against desiccation. When subjected to drought the protoplasm segments up into numerous pieces each surrounded by a protective cyst—the whole forming a hard brittle mass. When conditions again become favourable the cysts soften and the protoplasmic masses creeping out flow together again. When the reproductive period comes on the protoplasm clumps together into compact masses usually supported by secreted stalks attached to bark or other solid substance. These “**sporangia**” are of characteristic shape and colour in the different genera and species. The protoplasm in their interior gives rise to numerous small reproductive bodies or **spores** each enclosed in a hard protective cyst. These spores are blown about by the wind and under favourable moist conditions the protoplasm in their interior issues forth as a minute cell which swims for a time by the movements of a single flagellum but presently takes on an amoeboid character, and undergoes fission a few times. The amoeboid cells so

arising are gametes and the zygotes formed by their fusion give rise to the conspicuous syncytial stage—partly by simple growth accompanied by mitosis, partly by numbers of them crowding together and undergoing fusion.

Under the name *PROTEOMYXA* are frequently grouped together a number of interesting genera of rather uncertain affinities. Two members of the group may be mentioned as being of special interest. *Pseudospora* is frequently encountered in the laboratory during the examination of *Volvox* (see below, p. 38). It has the appearance of a small Amoeba (Fig. 10, A), and is to be seen creeping about in the *Volvox* colonies and devouring the cell-individuals. In a bad epidemic of *Pseudospora* the *Volvox* colonies may be almost entirely destroyed by its ravages. The

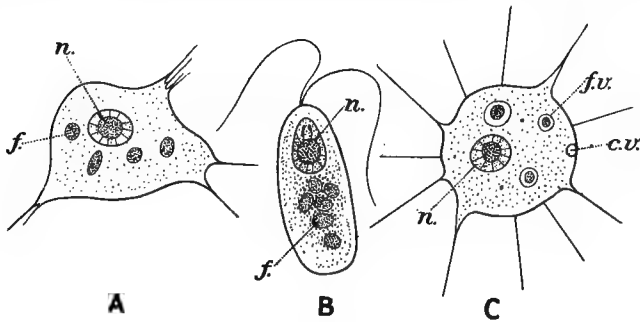

FIG. 10.

Pseudospora (from M. Robertson). A, creeping; B, swimming; C, floating phase. *c.v.*, Contractile vacuole; *f*, food; *f.v.*, food-vacuole; *n*, nucleus.

special feature, apart from its frequent occurrence, which makes it worthy of mention here is its remarkable polymorphism. On occasion it will take on an elongated form of body with two flagella at one end by the movements of which it swims actively through the water (Fig. 10, B). At other times (Fig. 10, C) it will become spherical with fine tapering pseudopodia radiating from it, and superficially placed contractile vacuoles, looking precisely as if it were a member of the group *Heliozoa* to be described below. *Pseudospora* thus illustrates particularly clearly, within the compass of its own life-history, three different physiological types of body which occur independently of one another very commonly in the Protozoa and which are associated respectively with a creeping, a swimming, and a floating habit of life.

Plasmodiophora the other genus is of interest as being the cause of the important disease of Cabbages and Turnips called Finger and Toe

disease from the projecting tumours which develop on the roots of plants affected by it. The life-history begins with a small flagellate, somewhat spindle-shaped, stage which hatches out of a spore. This makes its way into one of the cells of the plant and there grows enormously, forming a syncytium and causing the cell to swell up to an immense size. Eventually the syncytium breaks up into numerous small spores which surround themselves with a protective cyst and which when set free by the rotting of the plant are scattered about and serve to infect other plants.

The Protozoa mentioned up till now are linked together by the character of their pseudopodia, which are soft and frequently branch. This community is expressed by placing them in a group by themselves—the Rhizopoda—separated from the Actinopoda in which the thin tapering pseudopodia radiate stiffly from the body all round. Of the first section of Actinopoda—the HELIOZOA—we will consider first *Actinosphaerium* which is common in freshwater pools and excellently suited for laboratory study.

ACTINOSPHAERIUM

A well-developed *Actinosphaerium* is clearly visible to the naked eye as a round greyish-white spot when seen against a dark background. Under a low magnification it is seen to float freely in the water, spherical in form with stiff pseudopodia radiating out all round making it resemble the conventional figure of the sun and justifying its popular name “Sun animalcule.” As in the floating types of Foraminifera the cytoplasm (Fig. 11) is highly vacuolated, there being a superficial layer of vacuoles of specially large size marking the ectoplasm, while in the endoplasm the vacuoles are much smaller so that it has a more opaque appearance than the ectoplasm. Certain of the vacuoles of the ectoplasm—as many as 15 there may be in a large specimen—are contractile and when at the height of distension (diastole) they may be observed to bulge conspicuously beyond the general surface (Fig. 11, *c.v*).

The pseudopodia are extensions of the ectoplasm and examination with a very high power shows that each pseudopodium is supported by a stiff **axial filament** running up its centre and ensheathed in more fluid cytoplasm which shows slow streaming movement. By careful focusing on the extreme edge of the specimen the axial filament may be seen to extend as far as the outer limit of the endoplasm. The pseudopodia are used in feeding. If a small food-organism touches one it is paralysed and killed almost instantly. It seems to adhere to the pseudopodium which is reinforced by the neighbouring pseudopodia bending over to

its assistance. The pseudopodia then shorten and thicken and the food-particle is drawn down to the surface and finally into a food-vacuole, the ectoplasm closing over it. As the pseudopodium thickens and shortens the axial filament becomes resolved into ordinary fluid cytoplasm. It is therefore not a permanent structure but merely cytoplasm—possibly an extension of the endoplasm—temporarily modified for a special function.

The food-vacuoles pass down into the endoplasm where the digestive processes take place (Fig. 11, *f.v.*). In the endoplasm is also contained the nuclear apparatus which consists not of a single nucleus but of a large number—several hundred there may be in a large specimen. The Actinosphaerium is therefore a syncytium rather than a cell.

The life-history of *Actinosphaerium* shows some important features. Under ordinary circumstances the Actinosphaerium reproduces by a simple process of fission. At certain periods however, occasioned apparently by the onset of unfavourable conditions, a much more complicated process of

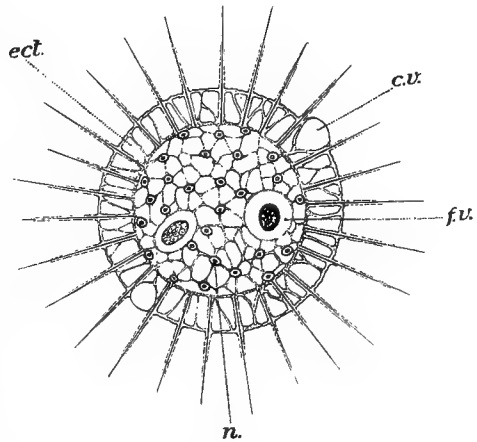

FIG. 11.

Actinosphaerium. *c.v.*, Contractile vacuole; *ect.*, ectoplasm; *f.v.*, food-vacuole; *n.*, nucleus.

reproduction, of a sexual type, takes place. The pseudopodia are withdrawn, the axial filaments disappearing, and the Actinosphaerium surrounds itself with a thick protective jelly-like cyst. The vacuoles practically disappear, and the protoplasm becomes uniformly granular and opaque, laden with minute particles some of which are apparently reserve food-material while others are particles of silica, afterwards used to strengthen the zygote cyst. About nineteen out of every twenty nuclei disappear and the protoplasm segregates round the remaining nuclei to form rounded uninucleate masses which are termed the **primary cystospores**. Each of these secretes a special jelly-like cyst and then within this divides with mitosis into two **secondary cystospores**. The nucleus of each of these undergoes mitosis without however this

being followed by cell-division. One of the two daughter nuclei in each case is simply pushed outside the protoplasm and got rid of. The nucleus which remains behind again undergoes mitosis and again one of the two daughter nuclei is extruded. In the place of each secondary cystospore there is now therefore a uninucleate cell with two extruded nuclei lying outside it. These extruded nuclei simply degenerate and play no further part. The two uninucleate cells on the other hand are soon seen to be gametes, for they undergo syngamy with one another to form a zygote. In the place formerly occupied by a pair of secondary cystospores and at an earlier period by a primary cystospore there is now therefore a zygote. This may be distinguished from a primary cystospore by its smaller size and denser protoplasm and by the cyst round it being thicker and reinforced by minute particles of silica extruded from its cytoplasm. After a prolonged rest, lasting normally for several weeks or months, the zygote—conditions being again favourable—makes its way out and resumes the form of a typical small *Actinosphaerium*.

This sexual reproduction of *Actinosphaerium* is of special interest and importance in two respects. (1) The extrusion of nuclei seen here as an essential integral part of the preparation or **maturation** of the gametes exemplifies a phenomenon very widely distributed throughout the whole Animal Kingdom. (2) On the other hand a glaring exception is seen here to a very general rule in sexual reproduction namely that the two gametes which conjugate together must not be close "blood-relations." We have here a striking example of extreme "inbreeding."

The general features of the Heliozoa are well exemplified by *Actinosphaerium*: the, with rare exceptions, freshwater habitat and the stiff radiating pseudopodia supported by axial filaments are particularly characteristic. The power of secreting particles of silica seen in *Actinosphaerium* during the reproductive period is much more highly developed in other members of the group, some of which form a definite supporting skeleton of silica.

Apart from *Actinosphaerium* the commonest Heliozoan in our freshwater pools is *Actinophrys* which is distinguished by its smaller size, its single centrally-placed nucleus and by the extension of the axial filaments inwards right up to the nucleus.

The group **RADIOLARIA** will be dealt with only briefly, not because they are not of great interest but because on the one hand specimens are not readily available for direct study and on the other hand they are not intimately linked up with medical or other studies of immediate practical importance.

Radiolarians are typically planktonic—floating in the waters of the open ocean. They present a superficial resemblance to Heliozoa through the presence of the slender, radiating, pseudopodia associated with the floating habit but in this case the pseudopodia are usually devoid of any axial filament. The protoplasm is as a rule divided into an outer and an inner portion by a membranous **central capsule** (Fig. 12, *c.c.*) with wide perforations the arrangement of which differs in different members of the group. The internal protoplasm is dense and granular and contains the nucleus. The external protoplasm on the other hand is reduced to a sparse network between large vacuoles containing watery fluid which as in the pelagic Foraminifera serve to bring the creature to the same specific gravity as the sea-water so that it hangs suspended without any tendency to rise or sink. In stormy weather the vacuoles shrink, the specific gravity is increased, and the creature subsides to below the limit of dangerous wave-action.

A most characteristic feature of the Radiolarian is its skeleton, composed as a rule of glassy silica. This may take the form of radiating rods of silica or, in addition to or instead of these, a lattice-work of silica is laid down in the external protoplasm (Fig. 12, *sk*) just below its surface. As growth continues the surface of the external protoplasm becomes further removed from the lattice-work and after a time another lattice-work is laid down, and then another and so on until there may be a number of clear flinty lattice-work shells arranged concentrically one within the other (cf. Fig. 13, left-hand figure). These skeletons of Radiolaria (Fig. 13) are in their marvellous variety of form and pattern amongst the most beautiful of microscopic objects.

There remains to be mentioned a remarkable feature which, though

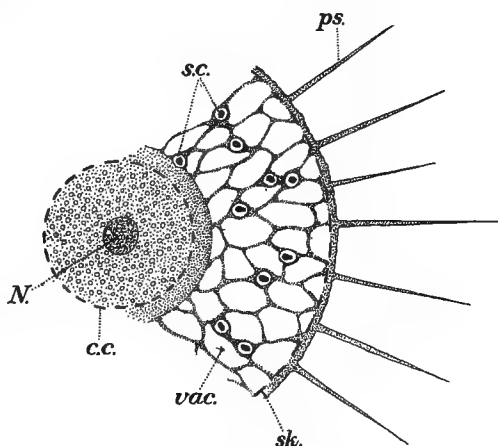

FIG. 12.

Diagram illustrating the structure of a Radiolarian. *c.c.* Central capsule; *N*, nucleus; *ps*, pseudopodium; *s.c.*, symbiotic cells; *sk*, skeleton; *vac.*, vacuole.

not an essential element in Radiolarian organization, is yet very generally to be observed, namely the presence, in the strands of external protoplasm, of numerous little rounded yellowish or greenish cells (Fig. 12, *s.c.*) apparently of extraneous origin which live and multiply sheltered within the body of the Radiolarian. Here we have an excellent example of what is known as **symbiosis**, in contradistinction to **parasitism**. In both cases we have two different types of organism living in close association e.g. the smaller living within or attached to the body of the larger. When the benefit arising from this association is entirely one-sided the biologist

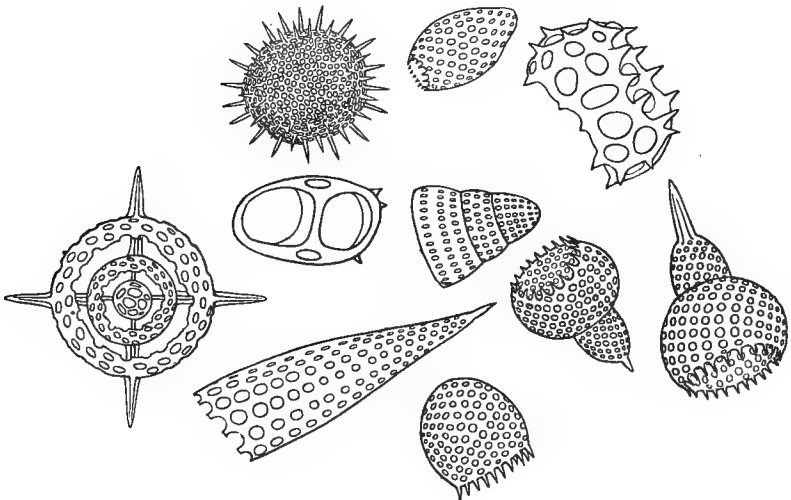

FIG. 13.

Skeletons of Radiolarians.

terms the beneficiary organism a parasite, when on the other hand the benefit is mutual, when the smaller organism makes some return for the hospitality it receives, the two organisms are said to be symbiotic. The small cells living within the body of the Radiolarian receive from it shelter and possibly a small amount of food-material, but on the other hand they contain a colouring matter like that of green plants which enables them to appropriate the carbon dioxide produced in the metabolism of the Radiolarian, retaining the carbon for their own use but setting free the oxygen to be made use of by the Radiolarian, so that we are clearly justified in speaking of these small cells as symbiotic.

Like the pelagic Foraminifera the Radiolaria play an important part

in forming submarine deposits. In their case too the dead and disintegrating bodies rain slowly down through the depths of the ocean. But the silica of their skeleton is much less soluble than the calcium carbonate of the Foraminifera. Consequently in deep regions of the ocean where both Foraminifera and Radiolaria are constantly sinking down from the surface layers the skeletons of the former are removed by solution before they reach the bottom while those of the latter persist and are deposited to form **Radiolarian ooze**. Deposits of fossil radiolarian ooze are found amongst the rocks of various parts of the world, as for example the comparatively modern deposits in Barbados and some of the flinty "cherts" which occur here and there amongst the more ancient rocks.

Glancing back over the Protozoa so far described we note that they possess this great characteristic in common that the outer layer of their protoplasm is soft and can be pushed out to form pseudopodia, and further, that they ingest food in the form of solid particles. These features unite them together in a group—the SARCODINA.

II. FLAGELLATA

In contrast with the Sarcodina the members of the next group—the FLAGELLATA—have the surface layer of their protoplasm more or less condensed to form a smooth bounding layer which is incapable of being pushed out into pseudopodia. We will first review the characters of three different genera of Flagellata which are easily obtained for laboratory study and thereafter consider certain genera which have been discovered within recent years to be of great practical importance as causes of disease in man and domestic animals. Two of the three genera first mentioned are characterized by their bright green colour due to their containing **chlorophyll**, the colouring matter which occurs in ordinary green plants, and the first of them often exists in freshwater puddles in such numbers that the water is throughout quite green and opaque.

EUGLENA

Euglena (Fig. 14) is a comparatively small creature (the commonest species *E. viridis* about 55 μ by 15 μ), somewhat spindle-shaped with one end blunt and the other pointed. Its smooth surface dips inwards close to the blunt end to form a conical **funnel** which expands at its apex into a spherical space—the **reservoir** (Fig. 14, r). From the funnel there

issues a long flagellum originating by a double root from the lining of the reservoir. In the centre or slightly nearer the pointed end is a large rounded nucleus, and close to the reservoir is a contractile vacuole (*c.v*) which expels its water into the reservoir. The animal is bright green in colour, the chlorophyll being situated in rounded discs—the **chromatophores** or chloroplasts (*chr*)—which are arranged in a single layer just below the surface. The chlorophyll is not the only colouring matter. Close to the contractile vacuole and just beneath the surface is a shining orange-red spot—the **stigma** (*s*)—which is physiologically an eye—not an eye which can “see” in the ordinary sense but merely a portion of the protoplasm sensitive to light and enabling the creature to detect from which direction the light is coming.

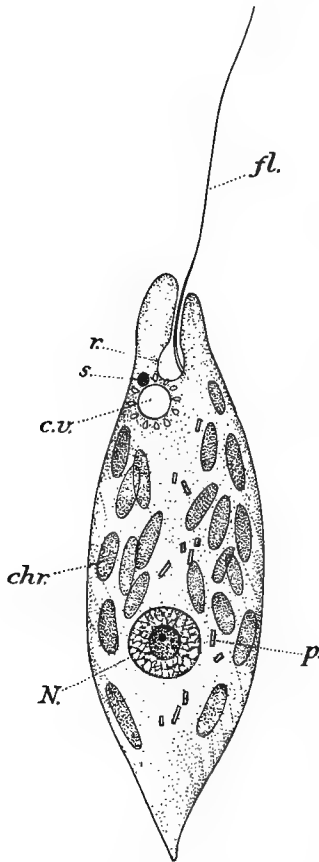

FIG. 14.

Euglena. *c.v*, Contractile vacuole; *chr*, chromatophore; *fl*, flagellum; *N*, nucleus; *p*, paramylum; *r*, reservoir; *s*, stigma.

As regards the life-history one of the chief peculiarities is a negative feature—the absence so far as is known of any process of syngamy. Ordinarily reproduction takes place by fission, the *Euglena* splitting longitudinally from the flagellar end. As a rule the *Euglena* is encysted in a clear jelly during the process and the young individuals surround themselves also with a cyst and then divide again. In this way great masses of jelly are formed with the dividing *Euglenas* contained in it. These, buoyed up by bubbles of gas, often form a conspicuous green scum on the surface of pools.

As regards the physiology of *Euglena* features of special interest are presented by its movements and by its mode of nutrition. The *Euglena* swims by means of its flagellum which is directed forwards and describes a conical or spiral kind of movement in such a way that the body of the *Euglena* is as it were towed after it. Such a type of flagellum is some-

times given the special name **tractellum**. When not swimming the *Euglena* may often be seen performing curious writhing movements so characteristic in appearance that such movement is termed euglenoid when met with elsewhere. The *Euglena* is seen to widen itself out about the middle of its length and then the swollen part gradually narrows again towards the two ends.

The main nutrition of the *Euglena* is like that of a green plant ("holophytic"), i.e. in the presence of daylight and by means of the green chlorophyll carbon dioxide is split up, the oxygen being set free in the form of bubbles while the carbon is elaborated into a substance termed **paramylum** almost identical in chemical and physical characters with starch. In *Euglenas* which have been exposed to light for some time the cytoplasm is crowded with bright shining rods of this substance (Fig. 14, *p*). In correlation with this mode of nutrition the living *Euglena* shows a tendency to swim towards the light ("positive heliotropism") provided it is not too bright. A culture of *Euglena* in the laboratory contained in a glass trough will gradually concentrate towards the end of the trough nearest the window where the light conditions are at their optimum.

The *Euglena* is not entirely restricted to the holophytic type of nutrition. A laboratory culture is found to be benefited by the addition of a little organic food-material in solution and this would appear to indicate that a certain amount of absorption of such food-material can take place through the general surface of the body.

COPROMONAS

Copromonas (Fig. 15) is a small pear-shaped inhabitant of fresh water measuring about 16μ by about 7μ or 8μ . It may usually be obtained in quantity by keeping the contents of the large intestine of a frog or toad in a little water for six or seven days at ordinary room temperature. The shape of the creature is fixed owing to the outer layer of cytoplasm being more condensed and stiffer than is the case with *Euglena*. Close to the narrower end the surface layer is turned inwards to line a long gradually tapering funnel which as it is used for the ingestion of food we may call the **oesophagus** or gullet. The single long flagellum (*f*) projects from the oesophagus and may be traced inwards along its wall to its origin in a deeply staining dot known as the **basal granule**. Close to this latter there is usually to be seen a reservoir (*r*) with a small contractile vacuole (*c.v*). Embedded in the cytoplasm, rather towards the broad end of the creature, is the nucleus (*N*)—

rounded in form and having its chromatin concentrated in a large central mass.

In ordinary movement the flagellum acts like that of *Euglena*—as a tractellum by which the animal is towed along. When moving slowly the spiral or conical movement may be seen to be confined to a small portion of the flagellum near its tip while in more rapid movement the whole flagellum is thrown into action.

The *Copromonas* feeds on bacteria and other small solid particles of food-material which pass down the oesophagus and are ingested by the soft exposed cytoplasm at its inner end. The ingested food-particles soon become surrounded by fluid secreted by the protoplasm and in the food-vacuoles so formed, which usually remain in the neighbourhood of the broad end, the food-material gradually undergoes the process of digestion.

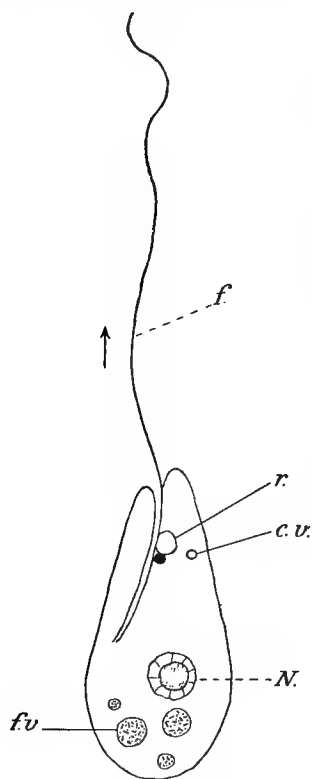

FIG. 15.

Copromonas (after Dobell, from *Lectures on Sex and Heredity*, by Bower, Graham Kerr and Agar). *c.v.*, Contractile vacuule; *f.*, flagellum; *f.v.*, food-vacuole; *N.*, nucleus; *r.*, reservoir.

When a *Copromonas* is kept under favourable conditions it feeds actively and grows and when the limit of size has been reached it proceeds to reproduce, resolving itself into two individuals by a process of longitudinal fission (Fig. 16). The flagellum is drawn in; the nucleus becomes transversely elongated; the basal granule divides into two—a new flagellum sprouting out from each.

A constriction now cuts into the creature from the flagellar end (Fig. 16, 3); the reservoir and the nucleus divide into two and as the constriction deepens the

Copromonas becomes completely divided into two new individuals which presently separate and swim away, the whole process taking about twenty minutes.

This reproduction by fission does not go on indefinitely: at a variable period (two to six days) it is interrupted by the converse process—that of syngamy.

The gametes (Fig. 16, 6) are to all appearance ordinary individuals: they may happen to be slightly different in size (e.g. as in Fig. 16, 7) but this appears to be purely a matter of chance. They become attached

by their flagellar ends, one flagellum is drawn in and the bodies of the two individuals gradually undergo a process of complete fusion (Fig. 16, 7 to 10). While this is taking place the nucleus of each individual divides into two (Fig. 16, 7) one of the two daughter nuclei degenerating: here we have clearly a maturation process comparable with that of *Actinosphaerium* (p. 30). In the case of *Actinosphaerium* a second nuclear division of this kind took place and in *Copromonas* this is apparently represented by the extrusion of one or more small granules of nuclear material from the nucleus (Fig. 16, 8). The two nuclei having thus prepared themselves they approach one another and fuse together (Fig. 16, 10 to 11) to form the single nucleus of the zygote.

The process of syngamy is followed by encystment, either directly (Fig. 16, 11) or after a period during which the *Copromonas* swims about and undergoes fission in the ordinary manner (Fig. 16, short circuit from 9 to 5). The encysted stage here as in other Protozoa is a device for getting through unfavourable conditions. During it the *Copromonas*

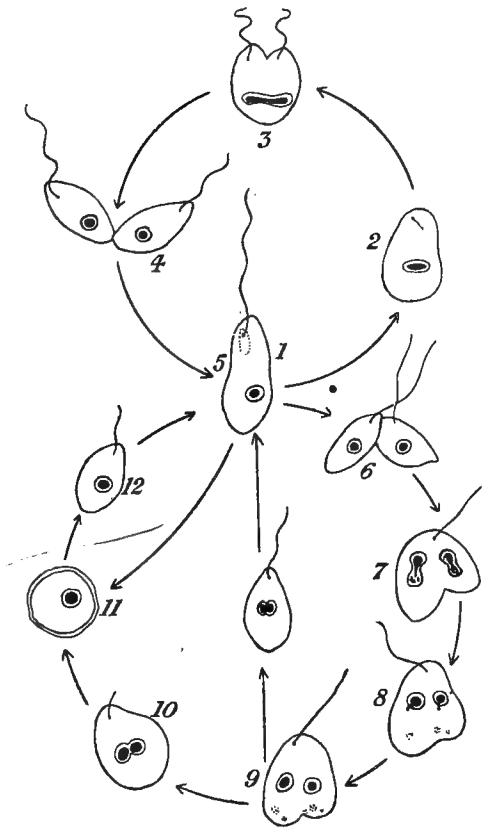

FIG. 16.

Diagram illustrating the life-history of *Copromonas* (after Dobell, from *Lectures on Sex and Heredity*, by Bower, Graham Kerr and Agar). The upper circle of figures (1 to 5) illustrates the process of reproduction, the lower circle (5 to 12) that of syngamy.

is able to withstand such vicissitudes as drying up for a considerable period. The *Copromonas* is no doubt swallowed in this stage by the frog or toad and passing through the alimentary canal is eventually voided in the faeces.

VOLVOX

The genus *Volvox* owes its most conspicuous difference from the flagellates hitherto described to a peculiarity in its method of fission. When the cell-individual undergoes fission the resulting individuals instead of separating and leading an independent existence remain attached together by slender threads of cytoplasm so as to form a **cell-community** or colony.

The cell-community (Fig. 17, A) is spherical or slightly ellipsoidal in shape. It consists of many, it may be several thousand, cell-individuals and is large enough (up to nearly 1 mm. in diameter) to be distinctly visible to the naked eye. Each cell-individual (Fig 17, B) is ellipsoidal in form and is surrounded by a thick jelly-like envelope, the envelopes of the various individuals taking a prismatic form owing to their mutual pressure and together constituting the thick wall of the colony in which the cell-individuals are embedded. Each cell-individual possesses a pair of flagella which project beyond the surface of the jelly into the surrounding water, a pair of contractile vacuoles (Fig. 17, B, *cv*) which contract alternately, and a rounded nucleus (*n*). The greater part of the cell, all except its outer end, is ensheathed in a thin green chromatophore and at one point embedded in the chromatophore near its edge is a bright orange stigma (Fig. 17, B, *st*). Finally each cell-individual is connected with its neighbours by extremely delicate thread-like bridges of cytoplasm (*b*).

During life the projecting portions of the flagella perform active lashing movements by which the colony is propelled along in a characteristic manner which led an examination candidate to describe *Volvox*, correctly if not very clearly, as a creature which "moves in a direction at right angles to that in which it goes." What happens is that the *Volvox* colony rotates and at the same time advances along a line which is roughly the axis of rotation. In other words the movement is somewhat similar to that of a rifle bullet although not so regular. This peculiarity in the movement of the *Volvox* community is correlated with peculiarity of structure in the cell-individuals, for stigmata are present only in the individuals situated in that hemisphere of the colony which is in front as the colony moves, and further the stigma is situated on the side of each individual which is in front. In other words the

stigmata or eye-spots are concentrated both in the colony as a whole and in the cell-individuals towards that pole of the colony which is in

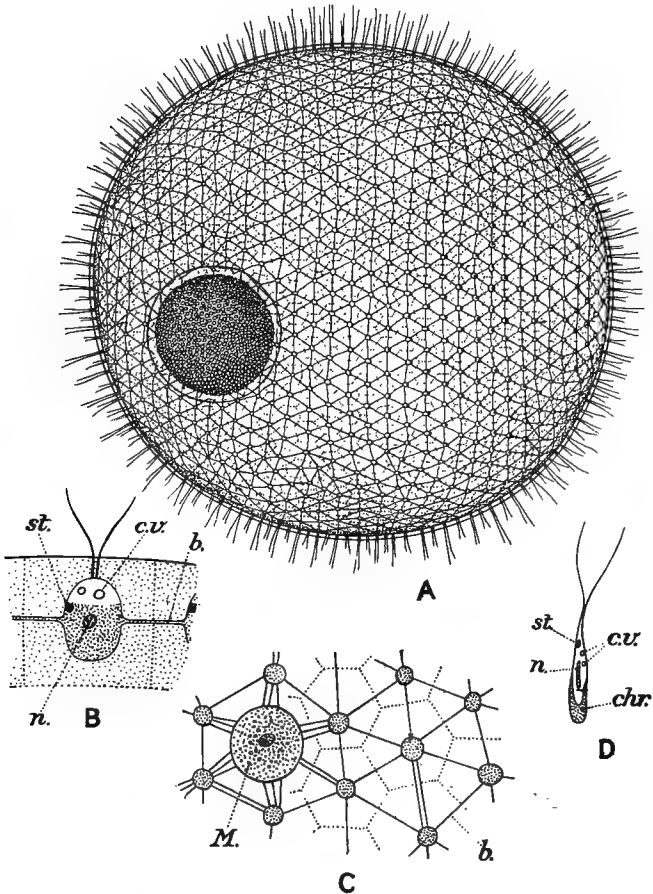

FIG. 17.

Volvox. A, View of a whole colony containing a single daughter-co'ony; B, a single cell-individual very highly magnified; C, part of colony as seen in surface view under a high power; D, a single microgamete very highly magnified. *b*, Protoplasmic bridge; *c.v.*, contractile vacuoles; *chr*, chromatophore of microgamete; *M*, macrogametocyte; *n*, nucleus; *st*, stigma.

front during movement. Putting it crudely and not quite accurately "the eyes look forward."

The features that make *Volvox* a creature of very special scientific interest and importance are connected with the reproductive processes

by which new communities are produced. The first of these processes is an asexual one. Certain cell-individuals from 20 to 35 in number and situated usually in the hinder hemisphere of the colony become distinguished from their neighbours by their larger size. These are special reproductive individuals. As a rule only eight of these proceed to carry out their function. In this event the reproductive cell-individual continues to increase in size and undergoes repeated fission, dividing into two, four, eight, sixteen, and so on, forming a plate of cells which as the process continues curves into the form of a saucer. With increased curvature the saucer deepens to form a cup and finally the mouth of the cup becomes narrowed and eventually obliterated so that it takes the form of a complete sphere. This is a young daughter-colony. It stands out conspicuously in the substance of the mother-colony by its deeper green colour, the green cell-individuals composing the daughter-colony being still in close contact while those of the mother-colony are spaced out by the intervening colourless jelly. The daughter-colony presently makes its way from the wall of the mother-colony into its cavity which is occupied by a very watery jelly, almost pure water, and here it may be seen for some time gradually increasing in size, performing the ordinary movements, and eventually bursting its way out and leading an independent existence.

This is the normal mode of increase of the *Volvox* communities but it does not go on indefinitely. After a time a new, sexual, type of reproduction takes place. This is again inaugurated by the appearance of special reproductive individuals which are in this case **gametocytes** i.e. cells which are destined to give rise to gametes. And when the further development of these is watched they are seen to belong to two different types—male or **micro-gametocytes** and female or **macro-gametocytes**—for here for the first time we find a differentiation of two sexes.

The macrogametocytes (Fig. 17, C, M) are at first very much like the asexual reproductive individuals being like them distinguished from the ordinary cell-individuals by their greater size. They are without flagella. They increase greatly in size, becoming about as large as a daughter-colony is before its cells become pushed apart by the secretion of jelly. They are spherical in shape and are easily recognizable by their dark green colour and their very dense granular cytoplasm which is laden with particles of yolk or reserve food-material. The macrogametocyte undergoes a process of maturation, involving divisions of its nucleus, and thereafter it is capable of syngamy and we speak of it as a **macrogamete** or egg. There are commonly about 30 macrogametes in all developed in a single colony.

The microgametocytes are found in very young colonies and may form a large proportion of all the cell-individuals. Each microgametocyte divides repeatedly by fission, forming eventually a slightly curved disc composed of numerous elongated cells—the **microgametes**. Each microgamete (Fig. 17, D) possesses the same details of structure as the ordinary individual of the colony only the proportion and arrangement of these are different. In shape it is much more slender, one end being drawn out to a fine point and the other rounded. The pointed end is prolonged into the two flagella which are long and powerful. The nucleus is elongated, the stigma well developed, and the chromatophore is situated at the rounded end. When the flagella of the microgametes become active the whole mass is moved about and it may make its way out of the colony. Sooner or later however the microgametes separate and swim away through the water as independent cells. If one of these comes into the neighbourhood of a colony containing a macrogamete it bores its way in and syngamy takes place. The zygote immediately proceeds to surround itself with a clear transparent cyst or shell and the presence of this affords a conspicuous character by which the zygote can be at once recognized and distinguished from a macrogamete. When the colony as a whole dies and disintegrates the zygotes fall down into the mud and remain there within their protective shell or envelope until conditions are favourable for their development into adult colonies.

The study of *Volvox* introduces us to several matters of general biological importance. While the *Volvox* consists of ordinary cell-individuals these are not independent but are linked together into a community which constitutes itself an individual of a higher order. And the cells which form this individual are sharply differentiated into two sets—the ordinary cells and the reproductive cells. The importance of this lies in the fact that here for the first time we find an arrangement that is universal among the higher animals, the body of which invariably consists of a great mass of non-reproductive cells known as the soma, and a special set of purely reproductive cells known as the gonad (see p. 85).

We see also in *Volvox* a differentiation of two sexes. This consists fundamentally of a specialization of the gametes in two different directions. Essential features of the gametes are (1) that they shall have the power of uniting in syngamy and (2) that the resulting zygote shall possess, stored up in its cytoplasm, a sufficiency of yolk or food-material to start the new colony on its way. To facilitate the achievement of the first the gametes are differentiated into (1) a stationary type without flagella, and (2) a highly active type with greatly developed flagella which is

able to swim rapidly. The first type is the macrogamete, female gamete or egg: the second is the microgamete, male gamete, or **spermatozoon**. The yolk or food-material is concentrated in the non-motile female gamete and this leads to these gametes being large in size and therefore few in number; while on the other hand the male gametes are small in size and developed in great numbers.

To prevent inbreeding micro- and macrogametes are not developed in the same colony at one time. They are either developed in separate male and female colonies or the sexual colony is at first male—producing microgametes—and then becomes female later on.

Having passed in review the main features of three illustrative genera of flagellates as seen from the point of view of pure science we will now proceed to study certain genera which are of special practical importance from their having adopted a parasitic mode of life and being thereby in some cases seriously harmful to the welfare of the host in whose body they have taken up their abode.

TRYPANOSOMA

Animals belonging to the genus *Trypanosoma* seem to have been observed as far back as the year 1843 when specimens were found in the blood of the frog by Gruby. It is only within the last two decades however that trypanosomes have excited very special interest owing to the fact that a number of important diseases have been traced to their agency.

A typical trypanosome (Fig. 18) is elongated and somewhat spindle-shaped, one end being rather more pointed than the other. The pointed end is prolonged into a single flagellum (*f*) which is continued back along the side of the body for some distance, it may be throughout almost its whole length. The flagellum from its basal end forwards to the tip of the body lies at some little distance from the surface of the latter, being connected with it by a thin protoplasmic membrane (Fig. 18, *m*). This membrane looks like a kind of fin running along the body, the flagellum forming its thickened free edge: the membrane has a frilled appearance, the flagellum along its edge following a somewhat sinuous course. The cytoplasm of the trypanosome is finely granular: and superficially it is slightly stiffened to form a bounding layer. The nuclear apparatus is very characteristic. Somewhere about the middle of the creature is a conspicuous nucleus (Fig. 18, *n*), rounded or oval in form, with a dense central mass of chromatin (**karyosome**) and smaller masses round the periphery.

Besides this main nucleus known as the **trophonucleus** there is present a small rounded or rod-like particle regarded by some as being also composed of nuclear material and believed to have to do with controlling the movements of the creature. This particle, commonly termed the **kinetonucleus** (Fig. 18, *k*), is in typical cases situated near the "posterior" (non-flagellar) end of the body although its position varies at different stages in the life-history. The flagellum originates close to the kinetonucleus, usually in a small granule (**basal granule**—Fig. 18, *b.g.*).

The trypanosome multiplies by a characteristic process of longitudinal fission in which basal granule (and ? flagellum), kinetonucleus, trophonucleus and protoplasmic body divide in the order named. Whether during this process the flagellum undergoes longitudinal splitting, commencing at its basal end, or whether on the other hand only the basal granule splits and a new flagellum sprouts out from one of the two resulting granules, seems to be still a matter of doubt.

As is the case with *Euglena* there appears to be no process of syngamy in the life-history of *Trypanosoma*.

The Trypanosome is typically a parasite of the blood of a vertebrate. Its conveyance from one host to another is typically carried out through the agency of some blood-sucking animal, such as a blood-sucking fly or flea in the case of terrestrial animals or a leech in the case of those inhabiting water, and, in accordance with this, part of the life-history is specially adapted to existence in the body of this intermediate host.

As an example of a trypanosome life-history we will take that of *Trypanosoma gambiense*—the parasite of sleeping sickness. This is essentially a parasite of mammalian blood, in which when abundant it may be seen readily with a high power of the microscope, wriggling through the fluid and knocking about the corpuscles in its course. When infection takes place the few trypanosomes inoculated into the blood multiply rapidly and they may become very numerous. The numbers in the blood do not remain constant at any maximum but at varying intervals undergo great reduction, all except comparatively few dying off. When the blood is examined at this time, before the trypanosomes again increase

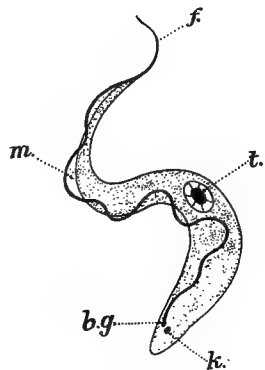

FIG. 18:

Trypanosoma gambiense.
b.g., Basal granule; *f*, flagellum; *k*, kinetonucleus; *m*, membrane
t, trophonucleus.

in number, it is found that the trypanosomes which survive through this "period of depression" are characterized by their short stumpy form (Fig. 19, A). These short stumpy trypanosomes, which are apparently endowed with special powers of resisting unfavourable conditions, are of peculiar practical importance for when a meal of infected blood is taken in by the transmitting insect—the blood-sucking fly *Glossina palpalis*—they alone survive and serve to infect the fly, all the other trypanosomes being killed and digested. It follows that the blood of a particular host is infective *only* when trypanosomes of this short stumpy type are present.

When blood containing them is swallowed by the *Glossina* the trypanosomes multiply actively in the fly's alimentary canal until they fill the whole intestine as a seething mass. Much variation is seen in both size and shape (Fig. 19, B, C, D) but at a period varying from about the eighth to the eighteenth day there begin to make their appearance trypanosomes which are conspicuous by their peculiarly long and slender form (Fig. 19, E). These gradually work their way forwards in the cavity of the alimentary canal and eventually (sixteenth to thirtieth day) make their way into the salivary glands (see p. 231). Here they attach themselves by their flagella to the lining of the gland and sway about within the cavity. They multiply actively, they become shorter in form and many are found to have the kinetonucleus on the flagellar side of the trophonucleus (Fig. 19, G). This is known as the Crithidial type from the name of a genus *Crithidia* which is distinguished from *Trypanosoma* by the position of its kinetonucleus. Amongst the others there also appear stumpy trypanosomes (Fig. 19, H) resembling those of the blood and it is apparently these which, injected into the blood when the *Glossina* bites, serve to start a new infection in the mammalian host. Ordinarily these infective trypanosomes make their appearance in the salivary glands from about the twentieth day after the fly has taken in the infected blood.

It will be noticed from the above life-history that the *Glossina* which serves to carry the trypanosome infection from one mammalian host to another is rendered capable of successfully inoculating the latter by the presence in its salivary glands of the short stumpy type of trypanosome which marks the final stage of the cycle within the fly. Here we have to do with what is known as the **cyclical** type of infection—dependent upon the completion of a definite life-cycle within the intermediate host. This contrasts strongly with what is known as **direct** infection in which a microbe is conveyed directly from one host to another by simple transference. Infection would be direct were individual

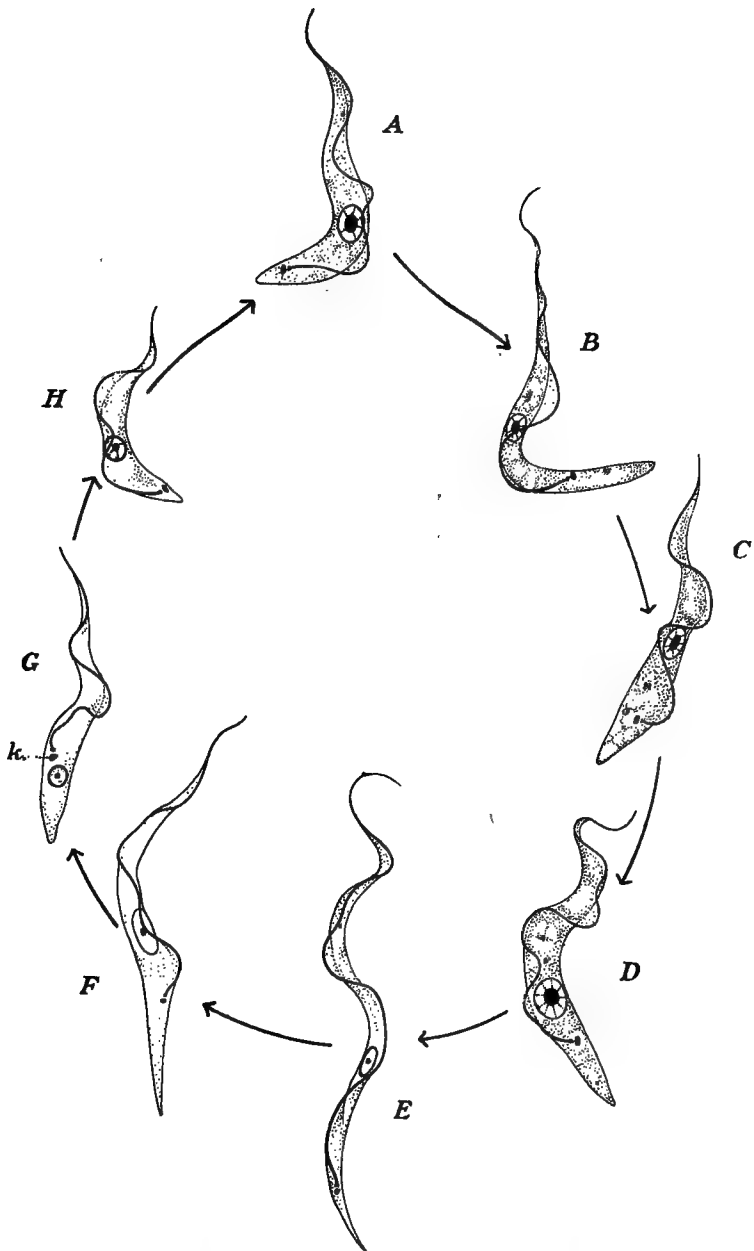

FIG. 19.

Trypanosoma gambiense. Stages in life-history passed in *Glossina* according to M. Robertson. A, Blood-type as ingested by *Glossina*; B, from intestine of fly 48 hours after ingestion; C, from intestine of fly on fifth day; D, from intestine of fly at twentieth day; E, from proventriculus; F, newly arrived at salivary gland; G, crithidial type from salivary gland; H, final type from salivary gland, *h*, Kinetonucleus.

trypanosomes to be sucked up in the infected blood and injected bodily into the blood of the new individual to produce infection therein.

All the detailed knowledge of Trypanosomes is of comparatively recent date. Many species have been described but our knowledge of most of these is very incomplete. In the following list we will confine ourselves to species which are of special interest and importance either practical or scientific.

T. brucei is of practical interest as the cause of Tsetse fly disease of domesticated animals in various parts of Africa, and of special scientific interest as being the species of *Trypanosoma* in which the method of transmission was first discovered. The disease ("Nagana") has long been known as occurring over large districts in Africa and as being invariably fatal to Horses, Asses and Dogs, and usually so to imported Cattle. These districts were known as "fly belts," the disease being associated with the bite of a particular species of fly (*Glossina morsitans*—"Tsetse"). It was suggested by David Livingstone that the disease was due to a living microbe injected into the bite, but the actual proof of this was first given by the experiments of David Bruce, which showed that any individual fly was powerless to cause the disease unless it had previously bitten a diseased animal. This clearly pointed to the poison being not something inherent to the fly but rather something which the fly merely transported from an animal already diseased. The fact that the infectivity of the fly appeared from these early experiments to last only for a period of about 48 hours after it had bitten the diseased animal pointed to the "poison" being really some living organism which was able to survive about the fly's proboscis for a period not longer than 48 hours. This suspicion led to the examination of the blood of diseased animals and in it Bruce duly discovered the trypanosome which we now know as *T. brucei*.

Subsequent research has fully borne out Bruce's discovery, with however an important amplification namely that a fly which has lost its primary or direct infectivity becomes again infective after a period of about 18 days, and apparently now remains so for the rest of its life. In other words there occurs here in addition to the direct infection first observed a cyclical infection which in all probability is the important one.

T. evansi causes a disease ("Surra"), somewhat similar to Nagana, affecting especially Horses and Camels. It probably is transmitted also by a biting fly—possibly a Horse-fly (*Tabanus*) or Stable-fly

(*Stomoxys*)—though this has not so far been absolutely determined. The disease occurs from India to the Malay Archipelago and the Philippines, and in various parts of Africa, while destructive epidemics have been caused by its being carried to Mauritius and Australia.

T. equinum causes the disease known as "Mal de caderas" which occurs in the form of very destructive epidemics amongst the horses of Paraguay and adjoining regions of South America. Dogs are also affected, as well as Tapirs, Carpinchos (Capybaras) and other wild animals. Nothing is known as to the mode of transmission.

T. equiperdum, the cause of the disease known as "Dourine" among breeding horses round the shores of the Mediterranean, differs from the trypanosomes hitherto described in being transmitted directly from one individual to another by sexual contact.

T. lewisi is of interest as being the trypanosome most easily obtained for purposes of study in most civilized countries. It is practically world-wide in its distribution and is to be found in the blood of Rats, especially of young individuals. The intermediate hosts are parasitic insects—especially fleas of various species.

T. gambiense was first observed in 1901 by Forde in the blood of a patient supposed to be suffering from malarial fever in the neighbourhood of the River Gambia. To this new trypanosome the name *T. gambiense* was given by Dutton. Other cases were observed and it was recognized that there existed a definite disease—"Trypanosome fever"—distinct from ordinary malaria. Just about the same time a deadly epidemic had been ravaging the native population of Uganda—a peculiar disease which had long been known on the West Coast as sleeping sickness from the drowsy lethargic symptoms of its later stages. A Commission was sent out by the Royal Society to try and find out the cause of the disease as a preliminary to the devising of means for its prevention or cure. In April 1903 a member of this Commission—Castellani—found a trypanosome in the cerebro-spinal fluid of a sleeping-sickness patient and at once suspected that this was the microbe which caused the disease. Bruce and his colleagues on the Commission confirmed Castellani's discovery and amplified it by discovering that the trypanosomes were invariably present in the *blood* of sleeping-sickness patients, while in the later and more typical stages of the disease they were present also in the cerebro-spinal fluid. The earlier stages of the disease were found in fact to be identical with "Trypanosome fever."

Bruce, the discoverer of the cause and means of transmission of Nagana, being a member of the Commission the suspicion naturally

came into his mind that the trypanosome of sleeping sickness might similarly be transmitted by a Tsetse or other blood-sucking fly. Blood-sucking flies were collected from all over the region of Africa under investigation and the localities in which each species occurred were plotted out on a map. When the distribution of the various species of biting flies was gone into, it was found that the distribution of one species—*Glossina palpalis* a close ally of the Tsetse—corresponded practically exactly with the distribution of cases of sleeping sickness. This was strong presumptive evidence of the correctness of Bruce's suspicion that sleeping sickness was a kind of human "Tsetse-fly disease."

Experiment soon demonstrated the truth of this. It was found that a *Glossina palpalis* which made a meal of infected blood was able to inoculate a monkey with the disease if allowed to bite it within a period of a few days. Thus, as in the case of *G. morsitans* with *T. brucei*, the possibility of direct infection was proved. Just as in the case of Nagana, however, further investigation showed direct infection to be of relatively minor importance. After a period of 20-30 days the fly was found in a certain small percentage of cases to recover its infectivity, the infectivity now lasting for several months if not for the whole life of the fly. This prolonged cyclical infectivity of the fly is associated with the trypanosome undergoing in its alimentary canal the various changes described on p. 44. Our knowledge of these changes is almost entirely due to the work of Miss Muriel Robertson.

It seems fairly clear that the cyclical transmission by *G. palpalis* is that which is of real practical importance in spreading epidemics of sleeping sickness. Direct transmission by the insect no doubt occurs occasionally but probably much more rarely. It must not be forgotten that *T. equiperdum* is conveyed by sexual contact and it is at least a possibility that this may happen occasionally also in the case of sleeping sickness—a possibility the less to be ignored in view of experiments (Hindle) which have shown that *T. gambiense* is able to make its way through thin skin.

For purposes of combating the spread of sleeping sickness three methods at once suggest themselves:—

(1) The segregation of sleeping-sickness patients within fly-proof houses so as to prevent new flies from becoming infected. This method is unfortunately made ineffective by the occurrence of *T. gambiense* as a natural parasite of the Sitatunga antelope (*Limnotragus*) which consequently acts as a persistent reservoir of the trypanosome.

(2) Destruction of the wild antelopes in the neighbourhood of human

settlements. The effectiveness of this will be conditioned by the extent, at present undetermined, to which animals other than antelopes act as natural carriers of the trypanosome.

(3) The local extermination or at least reduction in numbers of the transmitting *Glossina* (see p. 253). The most effective measure to this end is probably the clearing away of shade-giving brush and trees along the margins of rivers and lakes. Low thatched shelters may be constructed over loose dry soil near the water's margin so as to attract the flies of the neighbourhood, and induce them to deposit their pupae where they can readily be collected and destroyed. A further palliative may be found in the encouragement of fowls, Francolins and other scratching birds which are useful for unearthing and destroying the buried pupae.

(4) The withdrawal of the human population from the fly-infested zone along the margin of the fresh water. This, the most practical method, has actually been carried out on a large scale in the Uganda region, and has resulted in a reduction in the number of sleeping-sickness cases to comparatively small dimensions.

Of recent years (1909) "sleeping sickness," of a particularly virulent form, has made its appearance in Rhodesia and East Africa. In this region the transmitting agent is apparently *Glossina morsitans* and it is suspected that the trypanosome concerned is not *T. gambiense* but either a separate species ("*T. rhodesiense*") or a local strain of *T. brucei* which has developed the capacity of living in the blood of man. In either case the outlook is an anxious one owing to the wide distribution of the transmitting insect upon the continent of Africa.

*T.*¹ *cruzi*. In 1907 a new species of human trypanosome—*T. cruzi*—was discovered in Brazil. An interesting feature of the discovery was that the trypanosome was first observed as a parasite in the alimentary canal of a large bug (*Conorhinus*). By experiment it was determined that monkeys became infected with the trypanosome when bitten by the bugs, and the discoverer—Chagas—then proceeded to examine the blood of the human inhabitants of the district (Matto grosso) from which the infected bugs had been obtained. He found that the trypanosome was regularly present in the blood in cases of a severe illness particularly prevalent amongst children of the district. He also was able to make out that the transmission is cyclical, the bug not becoming infective until 10-25 days after sucking infected blood. A striking characteristic of *T. cruzi* is that the process of fission takes place normally not in the blood stream but in the substance of the muscles and other organs, the

¹ Often called *Schizotrypanum* instead of *Trypanosoma*.

trypanosomes drawing in their flagella and assuming a rounded or spindle shape as a preliminary to dividing.

LEISHMANIA

Leishmania. In Assam, Lower Bengal, and occasionally in other parts of India there occurs a somewhat malaria-like fever known as "Kala-azar." In 1900 Leishman discovered the parasitic cause of the disease—in the form of small rounded or oval bodies measuring about $4\ \mu$ by $3\ \mu$ or less, which are to be found embedded in the cytoplasm of the large amoeboid cells of the spleen (Fig. 20, A, L). The true nature

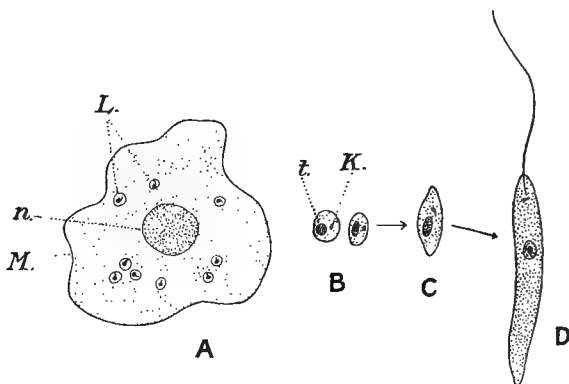

FIG. 20.

Leishmania. A, Large cell from human spleen containing nine parasites; B, two parasites more highly magnified; C, D, stages taken from artificial cultures. K, Kinetonucleus; L, *Leishmania*; M, host cell; n, nucleus of host cell; t, trophonucleus.

of these "Leishman-Donovan bodies" is hinted at by the fact that each when stained with a chromatin stain is seen to have within it two deeply stained structures—a larger rounded and a smaller rod-shaped (Fig. 20, B, t and K)—which clearly recall the trophonucleus and the kinetonucleus of a trypanosome, and Rogers was able to show eventually that when inoculated into certain culture media containing blood, especially if slightly acid, these bodies lengthen out, develop a flagellum and swim about as creatures resembling the genus *Leptomonas* (Fig. 20, D). Nothing definite is known regarding the transmission of the parasite but it has been found to develop into the flagellate form when taken into the alimentary canal of bugs and this suggests that these insects may be the normal intermediate hosts.

Three species of *Leishmania* have been clearly recognized so far :—

(1) *L. donovani*, the parasite of Kala-azar. This species has been found to occur in Dogs and possibly this animal is the normal host of the parasite.

(2) *L. infantum*, which produces an enlargement of the spleen, something like that of Kala-azar, in children in Algiers, Tunis and South Italy.

(3) *L. tropica*, which is found in superficial sores in the skin (Tropical Ulcer, Delhi Boil). As these occur always on exposed parts of the body transmission may in this case be effected by some flying insect. *L. tropica* occurs in Northern Africa and Asia, and appears also to be responsible for an ulcerative disease prevalent in some districts of Paraguay and Brazil and often mistaken for Syphilis or Yaws.

The Flagellata are Protozoa of usually comparatively small size and possessing in the normal adult phase of their life-history one or more flagella by the movements of which they swim. They show a remarkable variety in their form, while of even greater interest is the variety in their mode of nutrition. In attempts to draw a boundary between the animal and the vegetable kingdom a principal factor made use of is the difference in mode of nutrition—an animal typically nourishing itself by the ingestion of complex organic food material (holozoic nutrition) while a plant either builds up its complex organic material out of simpler components as in the case of green plants (holophytic nutrition) or else absorbs products of metabolism or decay by its general surface (saprophytic nutrition). The invalidity of any such general distinction is at once clear from the study of the Flagellata, for here we have an assemblage of creatures undoubtedly closely related together and yet making use of all three types of nutrition.

The great majority of flagellates live free lives in water but many members of the group have taken on a parasitic mode of existence. They are particularly common in the alimentary canal of various animals. Insects such as flies are very prone to harbour them (*Crithidia*, *Leptomonas*, etc.) and it seems probable that such forms as Trypanosomes are to be regarded as primitively insect parasites which with the development of the blood-sucking habit have spread to vertebrates.

III. SPOROZOA

We will commence the study of the Sporozoa by going over in some detail the life-history of two illustrative genera—*Monocystis*, chosen

because it is more easily obtained for laboratory study than any other Sporozoan, and *Plasmodium*, chosen on account of its great practical interest as being the cause of one of the most destructive of all diseases—Malaria.

MONOCYSTIS

Monocystis is a very common parasite of the ordinary earthworm *Lumbricus*. If the body of a freshly killed earthworm be slit open and the body wall pinned out flat so as to display the internal organs there will be seen towards the head end a clump of irregular yellowish-white organs known as the seminal vesicles (Fig. 67, p. 138). If a piece of one of these be pulled off with a pair of forceps and dabbed up and down in a drop of normal saline solution¹ the latter will be made milky by the whitish contents of the seminal vesicle. Examination with the microscope shows these to consist of various stages of the developing microgametes or spermatozoa of the worm. Amongst these a very conspicuous stage is that known as the **sperm-morula**, from its resemblance to a microscopic raspberry or mulberry (*morula*), spherical in shape and having its surface covered by a layer of little rounded bodies destined to lengthen out and become microgametes.

The young *Monocystis* is to be found as a small spherical or ellipsoidal cell embedded within the central protoplasm of the sperm-morula (Fig. 21, A). Within this it grows rapidly, absorbing nourishment from the surrounding protoplasm which becomes stretched out by the growing body of the parasite (Fig. 21, B) until eventually it forms merely a thin film (Fig. 21, C). In the meantime the microgametes of the worm have been going on with their development, each little rounded body becoming first pointed at its outer end and finally drawn out into a fine thread. When this stage has been reached the *Monocystis* is enclosed in a thick furry coat, each hair of which represents a spermatozoon of the worm. Eventually the *Monocystis* becomes freed from its furry coat and presents the appearance shown in Fig. 21, D. It contains a single round nucleus. Its protoplasm is bounded by contractile ectoplasm the surface layer of which is stiffened to form a distinct pellicle. The endoplasm is laden with stored-up food material in the form of highly refracting granules of paraglycogen, a substance allied to glycogen or animal starch, which give the *Monocystis* a snowy white appearance when seen against a black background by reflected light. The portion of the life-history so far described is above all characterized by the active absorption of food, which finds its expression first in growth and later in the storing up

¹ .75% Common Salt (NaCl) in water.

of reserve food material. This phase in the life-history is known therefore as the **trophozoite** phase.

The mature trophozoite lives for a time free in the cavity of the

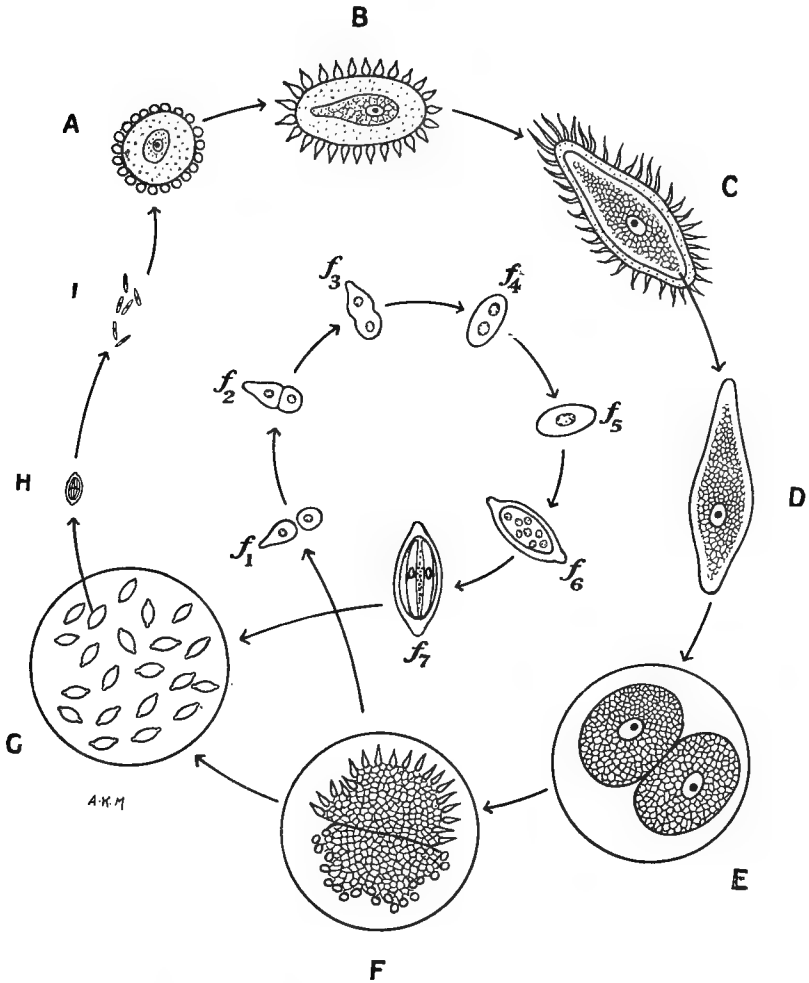

FIG. 21.

Monocystis. A-D, Stages in growth of trophozoite. In D the "adult" trophozoite is seen as it is found free in the cavity of the seminal vesicle; in A, B and C it is seen to be contained in the interior of the sperm-morula; E, gametocytes in cyst; F, formation of gametes; f1-7, details of process of syngamy; G, cyst containing pseudo-navicellae; H, pseudo-navicella free from cyst; I, group of sporozoites free from pseudo-navicella.

[The details of syngamy are such as have been actually observed in *Monocystis*. Probably the whole process resembles that shown in Fig. 22 which is taken from an allied genus, *Stylorhynchus*.]

seminal vesicle and then becomes a gametocyte. Two individuals enter into **association**, rounding themselves off, coming into intimate contact and surrounding themselves with a spherical protective cyst (Fig. 21, E). Each of the two individuals so associated together is a gametocyte. The nucleus of each individual undergoes repeated mitosis, giving rise eventually to a great number of small nuclei which take up their position in the superficial layer of the protoplasm. The latter takes on an irregular lobed shape and eventually each nucleus collects a small quantity of cytoplasm round itself to form a gamete. The gametocyte

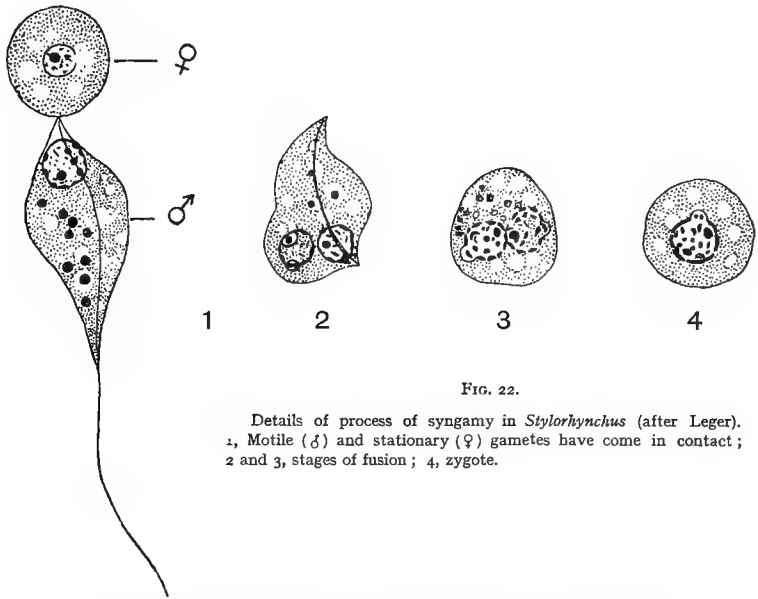

FIG. 22.

Details of process of syngamy in *Stylohrhynchus* (after Leger).
 1, Motile (♂) and stationary (♀) gametes have come in contact;
 2 and 3, stages of fusion; 4, zygote.

this is resolved into (1) an immense number of gametes and (2) a mass of **residual protoplasm** which is left over and disintegrates. A noteworthy feature is that the gametes derived from the two gametocytes differ in shape, the one lot being rounded the other pointed (Fig. 21, F), and may differ very obviously also in size. There now takes place an active quivering movement, the pointed gametes dashing wildly about—an indication that they are provided with a flagellum as is the case with the somewhat different species illustrated in Fig. 22. Syngamy now takes place between pairs of gametes one pointed and one rounded (cf. Fig. 22). In other words—of the two gametes which fuse together one is derived from each gametocyte. In this way (Fig. 21, f1-f5) numerous zygotes

are formed each of which takes on a spindle shape and surrounds itself with a characteristic boat-shaped cyst ("Pseudo-navicella" of microscopists). Within this cyst (Fig. 21, *f6*) the zygote divides with mitosis three times, becoming resolved into eight sausage-shaped bodies, each with a nucleus near its centre, the **sporozoites** (Fig. 21, *f7*). So far as is known nothing more happens during the life of the worm but if the worm dies and its body disintegrates or if it is digested by a bird the cysts are set free, their walls break down, and the "pseudo-navicellae" become distributed through the soil. Presumably when swallowed by an Earthworm the boat-shaped cyst is dissolved, the eight sporozoites are set free (Fig. 21, I) and make their way through the tissues of the worm to the seminal vesicle where they bore into sperm-morulae and start the life-cycle afresh.

PLASMODIUM

There exist probably a number of different species of malarial parasite and of these three have had their life-histories fully worked out. The relatively small differences in detail which mark off the species from one another will be indicated after a general sketch of the life-history has been given (Fig. 23).

As is well known malarial fevers are characterized by the recurrence of febrile attacks at definite intervals such as 48 hours or 72 hours. If a drop of blood taken from a patient at the end of one of his febrile attacks be examined microscopically the parasite will be found in the **amoebula** stage—a minute amoeba-like creature which creeps about slowly in the substance of a red blood-corpuscle (Fig. 23, A). The amoebula nourishes itself at the expense of the corpuscle and increases gradually in size (Fig. 23, B). As it does so a characteristic feature is the appearance within its cytoplasm of minute particles of a dark brown, almost black, pigment—one of the iron-containing pigments known to the chemist as **melanins**, a product of the digestion by the parasite of the red iron-containing pigment of the blood (Haemoglobin—see p. 141). It is also very usual for fluid to accumulate within the amoebula as a conspicuous vacuole which gradually attains to such a size that the parasite assumes the appearance of a signet-ring—the nucleus being pushed to one side (Fig. 23, C). With further growth the vacuole disappears and the parasite occupies the whole of the interior of the corpuscle. The portion of the life-history so far described is the trophozoite phase. The full-grown trophozoite now becomes a **schizont**, i.e. a stage which reproduces by schizogony. Its nucleus divides several times (Fig. 23, D) and the cytoplasm segments into a number of fragments

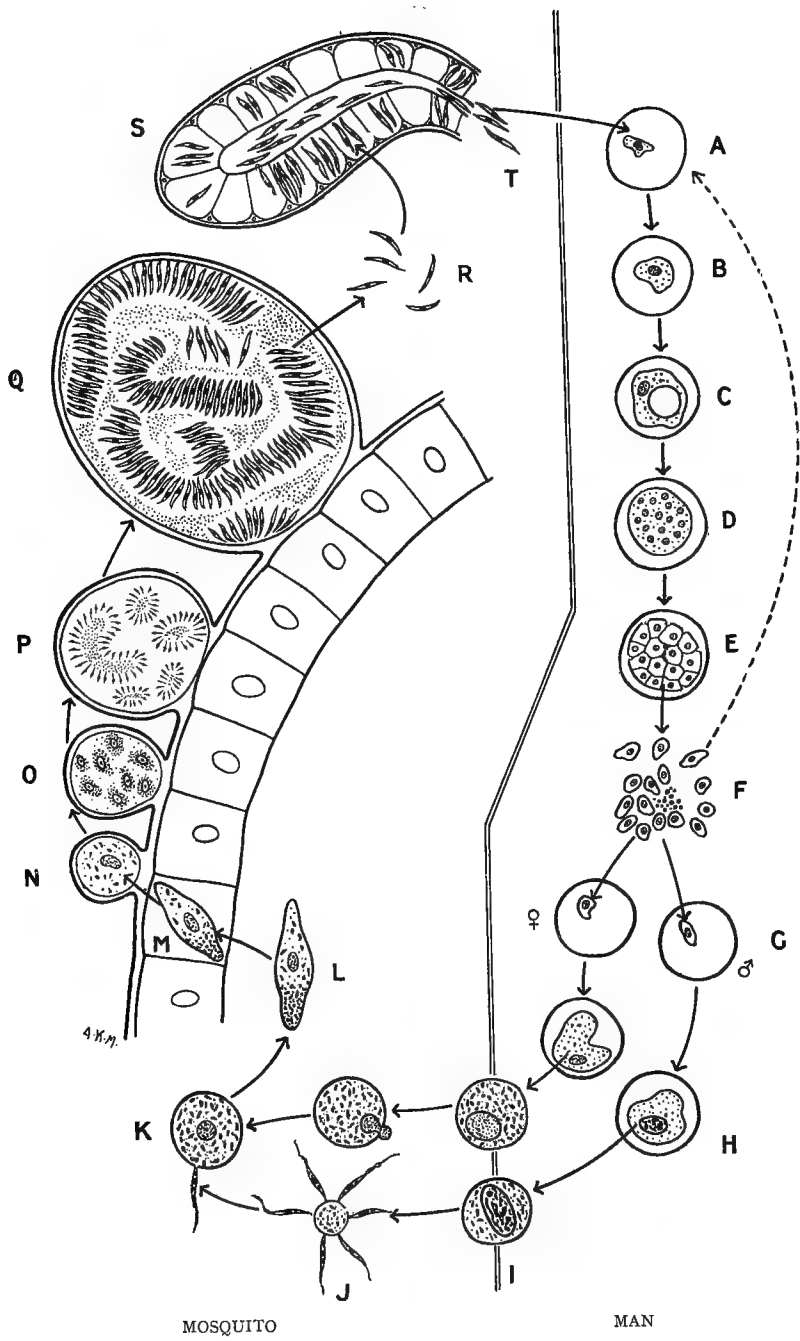

MOSQUITO

MAN

FIG. 23.

Life-history of *Plasmodium*. A-E, Stages of growth and division of schizont within red blood-corpuscles; A, B, young amoebulae; C, "ring" stage; D, schizont with divided nucleus; E, group of merozoites formed by subdivision of schizont; F, group of merozoites set free by rupture of corpuscle—the granules of melanin are left behind in a loose heap: F-A, the dotted line indicates the repetition of the schizogony cycle; G, amoebulae which will become male (δ) or female (\varnothing) gametocytes (H); I, fully developed gametocytes lying free in the blood; J, maturation of the gametes in stomach of mosquito—the upper (\varnothing) is extruding its polar body, the lower (δ) is giving off six slender microgametes. K, syngamy; L, actively moving zygote (ookinete); M, zygote has burrowed into one of the cells of the stomach-wall; N, it has rounded itself into a sphere on the outer surface of the stomach; O, it is increasing in size and dividing into sporoblasts; P, each sporoblast is developing slender sporozoites over its surface; Q, large round mass of sporozoites with residual protoplasm; R, sporozoites set free in blood of the mosquito by rupture of the mass; S, lobe of salivary gland, sporozoites are seen embedded in the cells of the gland while others have penetrated into the central duct; T, free sporozoites as injected into man.

[The schizogony part of the life-cycle (A-F) takes 48 hours in *P. vivax*, 72 hours in *P. malariae*. In *P. falciparum* it is less regular, occupying from 36 to 48 hours. The sporogony part of the life-cycle commonly occupies about 10-12 days.]

(merozoites) each containing a nucleus (Fig. 23, E). The corpuscle now bursts and in its place there remains the group of merozoites (Fig. 23, F) with the melanin granules collected in a little heap, having been extruded from the living protoplasm during the process of schizogony. The merozoites now creep away through the blood as little amoebulae which eventually bore their way into new corpuscles and start the cycle afresh (Fig. 23, F→A). The whole of this part of the life-cycle ending in the process of schizogony takes, in at least two of the species of *Plasmodium*, a definite period (48 and 72 hours respectively) for its completion, and its completion, the setting free of the merozoites, is punctuated by the onset of a febrile attack (Fig. 24) due apparently to some virulent poison or **toxin**, possibly the excretory material of the parasite, being set free in the blood along with the melanin when the corpuscles rupture.

The schizogony cycle goes on being repeated over and over again in the blood of the patient so long as the disease lasts. Its result is **auto-infection**, i.e. the spreading of the infection in the blood-corpuscles of the same individual host. Eventually however certain of the amoebulae which have entered blood-corpuscles are seen to be behaving rather differently from those destined to become schizonts: they are inaugurating a new and very complicated part of the life-history known as the **sporogony** cycle, characterized by the occurrence of a sexual process of syngamy, culminating in the production of sporozoites, and having as its special function the conveyance of the parasite to new host individuals. The amoebulae which start the sporogony (Fig. 23, G) increase in size within the corpuscles but when they reach the limit of their growth are not schizonts but gametocytes which become free from the corpuscle and may be seen as spherical cells (Fig. 23, I) lying free in the fluid of the blood. Two distinct types may be recognized—female macrogametocytes, rather larger, the cytoplasm more deeply staining and laden with particles of stored-up reserve food material, the nucleus situated on one side close to the surface—and male microgametocytes, rather smaller, the cytoplasm staining less deeply, and the nucleus large and central in position.

If blood containing fully developed gametocytes is drawn from the body and allowed to cool upon a slide under the microscope, more especially if moistened by being breathed upon, the gametocytes may be observed within a period of half an hour or so to give rise to gametes (Fig. 23, J). In the case of the macrogametocyte the nucleus becomes constricted across into two parts, one of which is extruded: the macrogametocyte is by this process of maturation converted into a macrogamete. In the case of the microgametocyte the single nucleus becomes

divided so as to produce small nuclei normally about six in number. The cytoplasm now becomes rapidly extended outwards into about six long slender threads into each of which there passes one of the small nuclei also elongated, almost threadlike, in form. These protoplasmic threads lash about violently like so many flagella, eventually tear themselves free from the central mass of cytoplasm—which then degenerates—and swim off actively through the fluid of the blood as so many microgametes. If it comes into proximity with a macrogamete, the microgamete dashes towards it, fuses with it (Fig. 23, K), and becomes drawn in and completely merged with its substance. Complete nuclear fusion

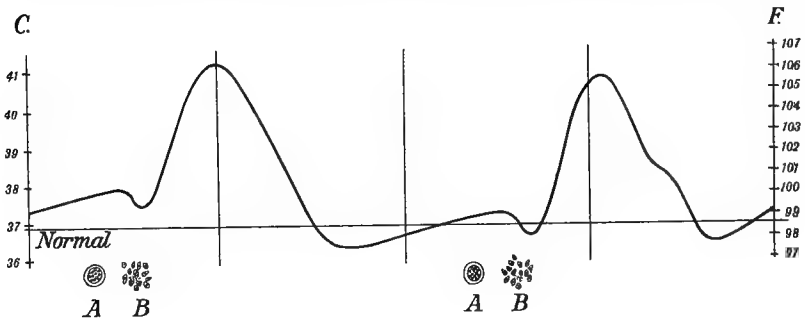

FIG. 24.

Curve showing the fluctuation in body temperature in a person suffering from Malaria caused by *Plasmodium vivax*. The temperature scale on the left is in degrees Centigrade, that on the right in degrees Fahrenheit. The horizontal line indicates normal temperature. The vertical lines are drawn at 24-hour intervals. Parasites (A, schizont; B, group of merozoites) are drawn below the curve to indicate the point about which schizogony takes place.

takes place and there now exists a zygote in place of the two separate gametes.

The fact that these processes of maturation and syngamy are induced by cooling the blood is correlated with the fact that this part of the life-history takes place normally in the body of a cold-blooded insect—a mosquito of the genus *Anopheles* or of one of the genera allied to it. When such a mosquito takes in a meal of malarial blood all the stages of the parasite except the fully developed gametocytes are promptly killed and digested. The gametocytes on the other hand give rise to gametes in the way described, and zygotes are formed by the process of syngamy. The zygote—the superficial layer of whose protoplasm becomes modified to form a distinct thin membrane—soon loses its spherical form, becoming somewhat pointed at each end, and becomes an actively motile zygote or **ookinete** (Fig. 23, L). This creeps about

within the cavity of the stomach of the mosquito, burrows through its wall and just outside the layer of cells which form the greater part of the thickness of the wall again rounds itself off into a sphere (Fig. 23, N). Its nucleus divides several times in succession and the cytoplasm segments into a number of **sporoblasts** each containing a nucleus (Fig. 23, O). Each nucleus now undergoes division a great many times in succession, the small nuclei making their way towards the surface of the sporoblast and a little mass of cytoplasm segregating round each to form a sporozoite (Fig. 23, P). These sporozoites are at first rounded but become spindle-shaped and later much elongated and shaped almost like the microgametes. During the process of sporozoite-formation the spherical mass of sporoblasts undergoes a great increase in size (Fig. 23, Q) and the number of sporozoites into which, with the exception of a certain amount of residual protoplasm, it is ultimately resolved is very vast. Eventually the delicate membrane enclosing the mass of sporozoites ruptures, the sporozoites are set free in the blood of the mosquito (Fig. 23, R), they bore their way through the cells of the salivary glands (Fig. 23, S) into its duct and when the mosquito next bites are injected with its saliva into the blood of the animal bitten (Fig. 23, T). If this be a human being or other suitable creature the sporozoite attaches itself to a red corpuscle, burrows into it, and becoming an amoebula starts the whole life-cycle afresh (Fig. 23, A).

Of the various types of malarial fever in man there are three which are particularly well marked and which have been investigated particularly completely. These are associated with three different species of parasite—*Plasmodium vivax*, *P. malariae*, *P. falciparum*.

P. vivax is the parasite of ordinary Tertian fever or Tertian ague as it used to be called. The period occupied by the schizogony is about 48 hours so that the fever attack occurs every other day (Fig. 24). A distinctive characteristic is the number of merozoites (15-20) composing the group derived from a single schizont (Fig. 25, B).

P. malariae is the parasite of Quartan fever or Quartan ague in which the schizogony cycle occupies 72 hours so that two successive fever attacks with the intervening period occupy four days. In it the number of merozoites arising from a single schizont is usually 6-12, and they often are arranged in a very regular **rosette** (Fig. 25, A).

P. falciparum is the parasite of "Tropical fever." In this case it is difficult to make certain of the exact period occupied by the process of schizogony owing to the fact that the breaking up of the schizonts takes place usually in the capillary blood-vessels of the brain, spleen and other

internal organs and not in the more accessible vessels of the skin. The period is most probably 48 hours ("malignant tertian fever") but it may be some other period or even irregular. The merozoites are usually 8-15 in a group and a marked diagnostic feature is the form of the fully developed gametocytes which until they become free from the corpuscle are sausage-shaped ("crescents," Fig. 25, D).

One of the unpleasantly interesting characteristics of malaria is its liability to recur in an individual who may have been apparently free from the disease for a prolonged period—several years—and who has not been exposed to any possibility of re-infection. It is clear that this must be due to some of the parasites lurking on within the body after the great majority have died off. It is most probable that during the periods of apparent health a few parasites are all the while going on

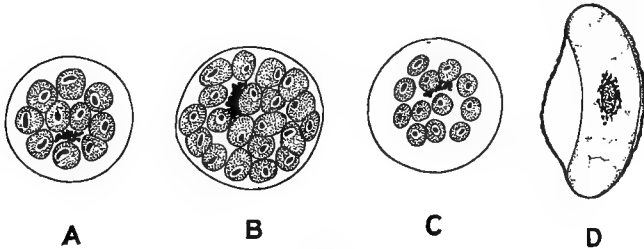

F.G. 25.

Malarial parasites showing characteristic differences between different species. A-C, Schizogony in *Plasmodium malariae* (A), *P. vivax* (B), and *P. falciparum* (C); D, gametocyte of *P. falciparum* enclosed within remains of blood-corpuscle.

with the normal cycle of schizogony—the total numbers never becoming large enough to cause obvious symptoms—although on the other hand it has been suggested that it is one particular phase of the parasite, namely the macrogametocyte, that is endowed with special powers of resistance and is capable of remaining for long periods dormant, awaiting the onset of favourable conditions, when it bursts into activity, behaves as if it were a schizont, and starts off the infection of large numbers of corpuscles.

It will be of interest before leaving the subject of the malarial parasites to note the names of the chief workers by whom our present knowledge has been built up. The foundation of this modern knowledge may be said to be the discovery by Lankester in 1871 of the first protozoan parasite of a blood-corpuscle—the genus *Drepanidium* or *Lankesterella* as it is now called—in the blood of the frog. The special foundations of our knowledge of the malarial parasites of man were

laid by Laveran (1880) who observed for the first time quite a number of the stages in the life-history—amoebula, merozoites, gametocytes. He even observed the formation of microgametes though he interpreted them as flagella and looked on their development by the “flagellated body” as an abnormal process. Laveran definitely held that these various appearances which he observed were stages in the life-history of a parasitic organism and that that organism was the actual cause of malarial disease, but for a long period his views met with little acceptance. In 1895 Ronald Ross fed mosquitos on the blood of a malarial patient containing “crescents” and observed the formation of the “flagellated body” within the insect’s stomach. In 1897 a most important step was made by MacCallum, who observing a parasite of the malarial type in the blood of a “crow” saw the process of syngamy take place before his eyes and consequently rendered clear the meaning of Laveran’s “flagellated body.” Meanwhile Ross was continuing his investigations in India. On feeding mosquitos (1897) with malarial blood containing crescents he as a rule got no result, but in one kind of mosquito with dappled wings he observed the parasites after 4 to 5 days lying embedded in the wall of the stomach, in the form of round cells containing the characteristic melanin pigment. Ross concluded that he had now found the normal insect host of the parasite, and although he does not name the mosquito it is clear from his description that it belonged to the genus *Anopheles*. Circumstances interfering at this point with his work on human malaria Ross carried on his experiments with a malarial parasite (*Proteosoma*) of Birds and was able (1) to show that in this case the transmitting insects were mosquitos of the genus *Culex* and (2) to work out practically the whole sporogony cycle. The working out of the corresponding details in the parasite of human malaria within the body of the *Anopheles* is due in great part to Grassi and his Italian colleagues (1898) and the final completion of the life-history may be said to have been achieved by Schaudinn (1902) who was able to observe the sporozoite actually attacking the blood-corpucle.

The group Sporozoa includes a great variety of Protozoa which are linked together by certain common features. They always live as parasites within the bodies of other animals. They are, in the full-grown condition, without cilia or flagella. Their surface protoplasm is condensed to form a thin pellicle without any openings and correlated with this they feed by simply absorbing nourishment through the general surface of the body. They fall naturally into two main groups according as to whether the reproductive processes are distributed through the

trophic part of the life-history, i.e. through the period of active feeding, or are concentrated into a special period at the end of the trophic stage. These two main groups are known as the Neosporidia and the Telosporidia.

A. TELOSPORIDIA

(1) GREGARINIDA. This group includes *Monocystis*. In it the trophozoite is at first intracellular, living embedded in the protoplasm of the host, but it is to be noted that the cell containing it is never a blood-corpuscle. The parasite becomes free from the host-cell before sporogony takes place and the number of sporozoites enclosed within one cyst or capsule is usually eight. The gregarines occur as parasites in most of the main groups of invertebrate animals except possibly the Mollusca.

(2) COCCIDIA. These occur as parasites in Arthropods (*e.g.* Centipedes), in Molluscs (especially Gasteropods and Siphonopods) and in Vertebrates (*e.g.* Rabbit). The trophozoite in this case remains throughout a more or less spherical intracellular parasite, growing within the host-cell and gradually destroying it. When fully grown it becomes a schizont and divides into merozoites which infect new cells and in this way great destruction of tissue may take place, resulting sometimes in the death of the host. Even without this a limit is reached in the activity of the schizogony process and sporogony takes place (also intracellular), gametes being formed which conjugate to form zygotes. The spherical zygote surrounds itself with a stout cyst which shelters it when it passes away from the protection of the host's body. Within this cyst the zygote divides into sporozoites the number of which differs in different members of the group. The sporozoites are set free when the cyst is swallowed by a suitable host and burrowing into host-cells start the life-cycle afresh as young trophozoites.

(3) HAEMOSPORIDIA. In this group—exemplified by *Plasmodium*—the trophozoite is for a time at least amoeboid and intracellular—the host-cell being usually the red blood-corpuscle of a Vertebrate. Reproduction takes place by schizogony, followed after a time by sporogony—the zygote giving rise to sporozoites which become free instead of remaining shut up within a cyst. Typically the sporogony or sexual cycle is gone through in the body of an intermediate host such as some species of blood-sucking insect.

Parasites closely allied to those which cause malaria in man occur in various mammals and other vertebrates. In Birds there occur commonly species of *Plasmodium*—sometimes separated off as a different genus under the name *Proteosoma*—and *Haemoproteus* in which latter

the gametocyte has a very markedly crescentic form. These species of *Proteosoma* and *Haemoproteus* are of historical interest for as already indicated it was in them that the process of syngamy was first observed (*Haemoproteus*) and the details of the sporogony cycle first worked out (*Proteosoma* of Indian Birds).

A group of parasites of great practical importance are those which are grouped under the generic name *Babesia* or *Piroplasma* (Fig. 26). These are small amoeboid parasites of red blood-corpuscles, commonly rounded or oval in form. Within the corpuscle they reproduce by fission so that commonly two occur together within a single corpuscle and sometimes four or eight. Whether or not a sexual or sporogony cycle occurs and whether or not there is an actively swimming flagellate phase are questions not as yet satisfactorily answered.

The best-known species of *Babesia* (*B. bovis* or *B. bigeminum*) is that which causes the very destructive disease of Cattle known by such names as Texas Fever—North America, Tristeza—Spanish America, Redwater Fever (*i.e.* Haemoglobinuria)—Australia. The life-history of this parasite was first blocked out by Smith and Kilborne (1893) in North America.

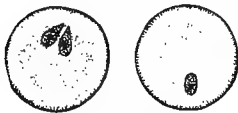

FIG. 26.

Babesia. Two red blood-corpuscles of a mammal infected with *Babesia*. In the corpuscle on the left the parasite has undergone fission into two.

The disease is endemic in various regions in the Southern States and Mexico. Cattle driven northwards during the warm season from these infected areas were found to infect pastures through which they were driven. Two important peculiarities were observed in this infection. (1) The herds of cattle were found gradually to lose their power of infecting new pastures as they were driven further and further northwards. (2) It was found that a newly infected pasture did not communicate the disease until at least 30 days had elapsed since the passage of the infective herd. Both of these puzzling peculiarities were explained when the mode of transmission of the parasite was worked out.

Transmission is carried out through the agency of intermediate hosts—Ticks (see p. 257) of the genus *Rhipicephalus* or *Boophilus*, the precise species being different in different parts of the world.

If, and only if, infected blood is taken in by an *adult female* Tick certain pear-shaped individuals of the *Babesia* leave the blood-corpuscles, put out long slender radiating pseudopodia, and wander away through the tissues of the Tick's body, some of them reaching the ovary and creeping into the substance of the eggs which become thus infected.

The tick at length drops off the animal whose blood it has been sucking and proceeds to deposit its eggs amongst the grass. These eggs, already infected while in the body of the parent, develop into infected ticks and these creep up on to grass blades and patiently wait for the opportunity of attaching themselves to an animal. Should this happen the animal bitten is inoculated with the *Babesia*, which occurs in the salivary glands of the infected tick in the form of swarms of "sporozoites." The details of the life-cycle within the body of the tick which culminates in the formation of these sporozoites is not yet completely worked out.

Besides the parasite of Texas Fever a number of other closely allied species are known. In various parts of Europe a similar parasite has been found in the blood of cattle and may be the same species. In South Africa practically all cattle have in their blood *B. mutans*, while occasionally a somewhat similar parasite—*Theileria parva*—causes destructive epidemics ["East Coast Fever"—South and East Africa, Central Asia, Japan, etc.]. Other species of *Babesia* occur in Dogs, Sheep, Horses, Mice, and other mammals. A conspicuous feature of the disease (Piroplasmosis or Babesiosis) is the destruction of red blood-corpuscles and the consequent passing away of the red colouring matter of the blood in the urine (Haemoglobinuria), and it is further a general characteristic that the transmission of the parasite is carried out through the agency of Ticks, in the body of which the parasite goes through a complicated and as yet not completely worked out cycle of developmental changes.

B. NEOSPORIDIA

The remaining members of the Sporozoa differ from those hitherto mentioned in the feature that reproductive processes go on throughout the period of active feeding and growth instead of being relegated to a point in the life-history subsequent to this. They are hence grouped together under the special heading Neosporidia.

(4) CNIDOSPORIDIA. Under this heading are grouped together a number of Sporozoa characterized by the fact that their spores possess peculiar bodies known as **polar capsules** (Fig. 27). A polar capsule is a pear-shaped hollow structure containing in its interior a spirally coiled hollow filament which can be instantaneously shot out so as to perforate any soft surface with which the spore is in contact and in this way anchor it in position. The extrusion of the filament commonly takes place in the alimentary canal of some animal that has swallowed the spore, and the spore thus is held in position attached to the lining of the alimentary

canal should it happen to have been properly situated in relation to this lining at the moment extrusion occurred.

A. Myxosporidia. This, the first sub-section of the Cnidosporidia, includes a number of common parasites of fish—usually harmless but occasionally causing destructive epidemics. They are to be found creeping about amongst the tissues of the body or within its cavities such as the urinary bladder or the gall bladder. They are more or less Amoeba-like organisms which creep by lobopods but which do not feed by them—nourishment being absorbed in solution by the general external surface. There is a distinct clear transparent ectoplasm and a granular endoplasm containing numerous nuclei. Within the endoplasm are produced the spores—by complicated processes, accompanied by sexual

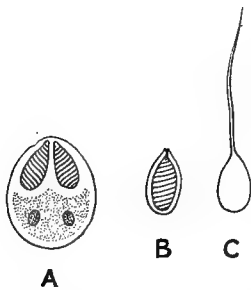

FIG. 27.

Cnidosporidia. A, Spore with its two polar capsules; B, a separate polar capsule; C, a polar capsule with its tube extruded.

fusion of nuclei, which need not be described in detail. Normally the process of spore-formation goes on continuously but it may be concentrated in particular seasons. Thus in *Myxidium*—a bright orange-coloured parasite found creeping about on the lining of the urinary bladder of the Pike—the process is almost confined to the summer months while in winter the creature reproduces actively by separating off bud-like outgrowths from its surface.

B. Microsporidia. This group includes a number of very small intracellular parasites occurring occasionally in Fishes but far more usually in Arthropods. Some of them are of practical interest as causing destructive epidemics in animals of economic importance (*Nosema bombycis*—Silkworm disease, *N. apis*—Bee disease). They are distinguished from Myxosporidia by their possessing only *one* polar capsule and filament.

(5) SARCOSPORIDIA. This group includes a number of intracellular parasites of the higher vertebrates, especially mammals, which are extremely common but the life-history of which is still very imperfectly known. The young parasite in the form of an amoebula makes its way into the interior of a muscle-fibre and absorbing nourishment grows actively, becoming eventually free from the muscle-fibre and taking the form of a long tendinous-looking thread or tube, reaching a length of it may be 16 mm. (Sheep) or even 50 mm. (Roe-deer). The parasite becomes enclosed in a distinct envelope which extends into its interior dividing it up into numerous chambers.

Within these there are formed enormous numbers of crescent-shaped spores.

These threads or tubes ("Miescher's tubes") are distinctly visible to the naked eye, and are common in butcher-meat. Sheep and Pigs are nearly always more or less infected, the parasites being particularly frequent in the muscular wall of the alimentary canal especially the oesophagus. A virulent toxin is commonly formed in the substance of the parasite but it is only in exceptional cases, as in the species found in the Mouse, that marked pathological symptoms are produced.

Nothing is known definitely as to the normal means of transmission though mice can be infected experimentally by feeding them on infected muscle. The fact that spores sometimes—possibly by bursting of the cyst—find their way into the circulating blood indicates at least the possibility of there being a blood-sucking intermediate host.

(6) HAPLOSPORIDIA. In this group are included a number of comparatively simple but still very insufficiently known parasites. They typically begin their existence as an amoebula which may reproduce repeatedly by fission but which eventually increases greatly in size, becomes multinucleate, and breaks up into numerous spores. These spores are simple in structure and are without the polar capsules which are so characteristic of the Cnidosporidia.

Some cause disease, sometimes very destructive epidemics, in Fish; one is found in a rare type of tumour of the nose in Man (*Rhinosporidium*), while others live within the bodies of various kinds of animals without producing any obvious pathological disturbance.

IV. CILIATA

The last great division of the Protozoa the CILIATA or INFUSORIA includes a vast assemblage of species showing wonderful variety in form and in the details of their structure. Included amongst them are the most complex and highly organized of all the Protozoa: some indeed—being unicellular—may be said to be the most complicated and highly organized individual cells known. We shall commence their study by considering in detail a very common member of the group, *Paramecium*, specimens of which are commonly to be seen in the form of minute white specks, just visible to the naked eye, gliding slowly about in fresh water in the neighbourhood of decaying organic matter.

Observed under the microscope a *Paramecium* is seen to have the form shown in Fig. 28. The body is limited by ectoplasm of remarkable complexity in which four layers can be distinguished. The outermost

of these—the **pellicle**—forms a tough membrane which bounds the surface of the creature and gives it its definite form. In a Paramecium which has been allowed simply to dry up on the microscope slide it may be seen that the surface of the pellicle is not absolutely smooth but is

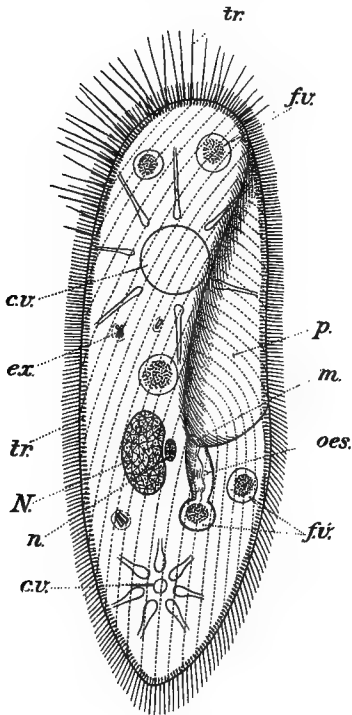

FIG. 28.

Paramecium. *c.v.*, Contractile vacuole surrounded by star of tributary vacuoles; *ex*, excretory crystals; *f.v.*, food vacuoles; *m*, mouth; *N*, macronucleus; *n*, micronucleus; *oes*, oesophagus; *p*, peristome; *tr*, trichocysts (some at the upper end of the figure have exploded).

sculptured into a minute honey-comb pattern. Beneath the pellicle is a layer of protoplasm which shows a fine striation in a direction perpendicular to the surface, and beneath it in turn is a layer characterized by its containing numerous shining spindle-shaped bodies also arranged with their long axes perpendicular to the surface. These bodies—the **trichocysts** (Fig. 28, *tr*) have a remarkable function. If the surface of the Paramecium be irritated the trichocysts suddenly explode, each losing its spindle form and taking that of a fine needle or filament. The exploding trichocysts, shooting out into the water all round, surround the Paramecium with an impenetrable entanglement which effectually keeps off the attacks of assailant organisms. The fourth or innermost layer of the ectoplasm consists of a spongy protoplasm in the meshes of which water collects from the fluid endoplasm. As the water in this layer increases in quantity it collects especially in two groups of radiating tubular channels situated respectively about half-way between the centre

and each end of the Paramecium. The water in the radiating channels collects towards their inner ends, and then slowly drains out of the channels into a central drop (Fig. 28, *c.v.*). When this has attained to its full size it suddenly discharges to the exterior, showing itself thereby to be a contractile vacuole. The process of expansion (diastole) and

contraction (systole) of the contractile vacuole is repeated rhythmically at intervals—commonly about five minutes, but varying with circumstances and with the individual.

The complexities of the ectoplasm are not exhausted by the features already mentioned: there remains one of its most characteristic features namely that it projects outwards in the form of innumerable little protoplasmic hairs or **cilia**. Each cilium is actively movable, being able to bend suddenly in a definite direction and then recover slowly. The cilia are present in enormous numbers, one arising from the centre of each of the little dimples that give the ectoplasm its honeycomb surface. The cilia work in unison, the rapid bending taking place in the same direction towards one end of the body. The result of the movements of the cilia, like thousands of little paddles, is to cause the Paramecium to glide slowly through the water, one definite end—that which is above in Fig. 28—being normally in front, although the movement is capable of reversal.

The endoplasm of the Paramecium is, so far as visible structure is concerned, comparatively simple. It is very fluid; it is granular in appearance—the granularity being due to the presence of minute particles of various kinds, such as excretory matter or reserve food-material. In the living Paramecium the endoplasm shows a slow circulation within its bounding layer of ectoplasm.

Embedded in the endoplasm lies the very characteristic nuclear apparatus. This consists of a large **macronucleus** (or meganucleus, Fig. 28, *N*)—kidney-shaped, and serving to carry out the ordinary nuclear function of controlling the general processes of metabolism—and a small rounded **micronucleus**¹ (Fig. 28, *n*) lying usually in the concavity of the surface of the macronucleus. So far as is known the micronucleus becomes functionally active only at the period of reproduction, in which process it plays a very important part.

The fact that the fluid endoplasm is enclosed within a comparatively stiff ectoplasm gives the Paramecium its definite form—rather elongated, slightly pointed towards the ends, the front end rather less pointed than the hinder one, and somewhat flattened. A broad shallow valley—the **peristome** (Fig. 28, *p*)—starts from one edge of the Paramecium near its front end and extends somewhat diagonally backwards across about one-half of its width. The somewhat oblique position of the peristome and especially of its hinder boundary causes the water pressure on the surface of the Paramecium as it glides along to give it a movement of

¹ In *P. caudatum*. *P. aurelia* a very similar species, also common, possesses two micronuclei.

rotation about its long axis which is very characteristic. At the hinder limit of the peristome is an opening—the **mouth** (Fig. 28, *m*)—at the edges of which the pellicle is turned inwards to form a wide somewhat curved and tapering tube—the **oesophagus** or gullet—which dips down into the endoplasm and is cut off sharp at its inner open end. During the life of the Paramecium a rapid flickering may be observed within the gullet. This is caused by the movements of the **undulating membrane**—a thin protoplasmic curtain (formed of a row of large cilia adhering together side by side) down which there pass in rapid succession waves of movement just like those produced on a large scale by moving one end of a curtain backwards and forwards. The undulating membrane performs an important part in the feeding of the Paramecium. Minute food particles such as Bacteria are whirled round by a vortex produced by the cilia of the peristome into the neighbourhood of the mouth where they are caught by the indraught due to the movements of the undulating membrane. They are carried down the gullet, collecting at its lower end and being forced into a drop of water which bulges from the inner end of the gullet into the fluid endoplasm. This drop (Fig. 28, *f.v*) increases in size as more and more water is forced into it until at length it detaches itself like a soap-bubble from the end of a pipe and passes away into the endoplasm as a typical food-vacuole. As it is carried round in the slow circulation of the endoplasm, much of the water of the vacuole is absorbed by the surrounding endoplasm, so that the vacuole diminishes in size. Acid is secreted into the vacuole to kill the food-organisms and this acid phase is succeeded by an alkaline one in which the food-material is attacked by the digestive ferments, the products of digestion being absorbed while the indigestible detritus is left as faecal material. Finally the vacuole approaches the surface and bursts to the exterior at a point between the mouth and the hinder end at which there is a definite small opening (**anus**) in the pellicle, the faecal matter being in this way got rid off.

The life-history of *Paramecium*, while of much less complexity than that of some of the Protozoa already described, is of great importance especially in relation to its reproductive processes. A healthy Paramecium, isolated and provided with abundant food, grows rapidly and as in the case of *Amoeba* this increase in size finds its corrective in a process of fission, the Paramecium becoming gradually constricted across into two individuals which for a time remain connected together end to end but eventually separate. Preparatory to this constriction the two nuclei divide—the macronucleus by a simple process of constriction, the micronucleus by a mitotic process—so that the young individuals are

provided each with a macro- and micronucleus like the parent. The two parental contractile vacuoles become the anterior vacuoles of the two new individuals. The mouths of the young individuals arise by division, of that of the parent. The original gullet persists as the gullet of the anterior young individual, while an outgrowth from it forms that of the posterior.

The two new individuals so arising proceed with their growth and presently repeat the process of fission. Under favourable conditions fission takes place at more or less regular intervals (*e.g.* about once in twenty-four hours) until it may be several hundred generations have been produced. In time however the interval between successive fissions becomes prolonged and eventually fission fails completely to take place. This loss of the power to divide is accompanied by general enfeeblement of the vital processes. There has come about a condition of **senility** or **depression** which unless counteracted will lead to the death of the whole culture. The process may be counteracted and new vigour given to the culture by various stimuli—such as changes of food or other factors in the environment—and if this corrective is applied in time the Paramecia go on dividing with renewed vigour and the onset of senility is deferred.

Amongst such antidotes to senescence the most important perhaps in nature is the process of syngamy. At a period before the onset of senescence the Paramecia develop a tendency to conjugate. Syngamy does not take place readily between individuals of an isolated culture such as has been described, in other words between closely related individuals. But if two broods are mixed together there comes about an epidemic of syngamy when the individuals are ripe. After this has taken place an isolated individual kept under favourable conditions will be found to be rejuvenated and to have regained its full powers of fission.

The minute details of the process of syngamy in *Paramecium* are of much interest owing to the striking peculiarity that the division of the gametocyte into separate gametes has become suppressed except in so far as the nuclei are concerned and the process of syngamy is no longer a process of fusion of complete cell-individuals but only of nuclei.

Two individuals (=gametocytes) become attached together by their oral surfaces and in this position may be seen swimming about in a normal manner. The micronucleus of each individual undergoes mitosis twice. Of the four nuclei so arising three degenerate and no longer function. The fourth on the other hand divides once again by mitosis and the two nuclei so arising are the functional gamete nuclei. We may take it that probably all four nuclei were once functional, each

dividing into two gamete nuclei, and that the whole individual (gametocyte) gave rise to eight gametes. In *Paramecium* as we now know it however three of the four nuclei have ceased to function and the division into distinct gametes has also disappeared from the life-history.

Of the two functional gamete nuclei in each individual one passes across into the other individual—the pellicle disappearing temporarily over part of the surfaces in contact to allow of this interchange taking place. The two nuclei now in each individual undergo fusion to form a zygote-nucleus, the gap in the pellicle is repaired and the two individuals—usually spoken of as **exconjugants**—separate. During the processes so far described the macronucleus has remained without change but it now begins to degenerate, it gradually breaks up into fragments which are digested by the cytoplasm, its rôle having come to an end with the process of syngamy.

Each exconjugant starts life provided with a single nucleus the zygote-nucleus which has arisen in the way described. In some allies of *Paramecium* the zygote-nucleus divides into two, one of which becomes the definitive micronucleus while the other rapidly increases in size to become the macronucleus. In *Paramecium* itself the process while essentially similar is obscured by repeated nuclear divisions followed by the degeneration of certain nuclei and is consequently unsuited for description in detail in an elementary book.

The group Ciliata contains a vast assemblage of different kinds of Protozoa which are classified into four sub-groups the scientific names of which are indicative of characteristic differences in regard to the cilia.

I. HOLOTRICHA. This section is characterized by the body being covered with a fairly uniform coating of short cilia. It is exemplified by the genus *Paramecium*.

II. HETEROTRICHA. Here also there are cilia distributed over most of the body surface but in this case the cilia round the edge of the peristome are greatly enlarged and concentrated into groups the cilia in each of which are fused together to form a **ciliary plate**. A good example of this section is the trumpet-shaped *Stentor* common in fresh water (Fig. 29, A). Interesting peculiarities of *Stentor* in detail are the presence of pseudopodia at its narrow end (*ps*) by which it attaches itself to the surface of water-plants or stones, the curious beaded (“moniliform”) macronucleus (*N*) and numerous small micronuclei (*n*), and the power of contracting itself with great rapidity into a rounded form. This last peculiarity is associated with the fact that special strands of ectoplasm have become highly specialized for the function of contraction (**myonemes**).

III. HYPOTRICHA. In these (Fig. 29, C) which usually resemble *Paramecium* in their general form, the cilia have disappeared except on the oral surface and here they have become restricted to localized tufts and fused together. At the edge of the peristome they form ciliary plates like those of *Stentor* but in addition to these there are a number of stout pointed structures—each formed of a group of fused cilia—on the tips of which the creature runs about as on so many legs. The movements of the Hypotricha as they run hither and thither on some solid surface in an apparently purposeful manner form perhaps their

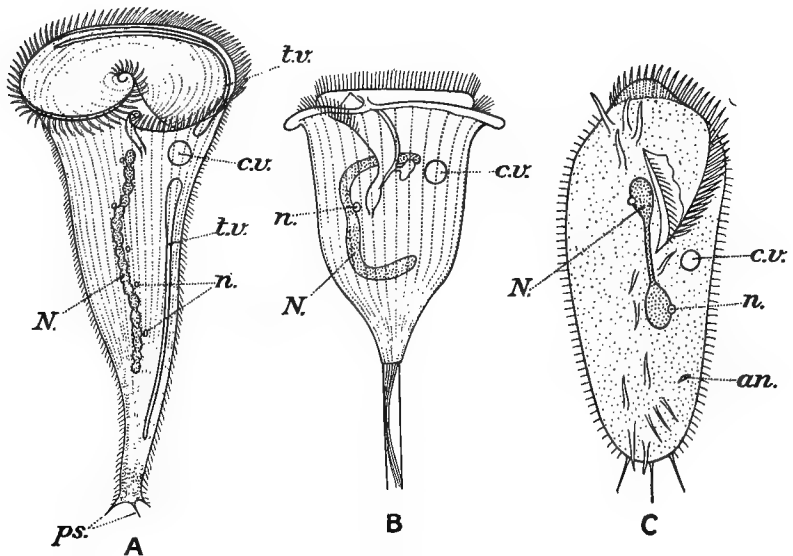

FIG. 29.

Examples of Ciliata. A, *Stentor*; B, *Vorticella*; C, *Stylonychia*. an, Anus; c.v., contractile vacuole; N, macronucleus; n, micronucleus; ps, pseudopodia; t.v., tributary vacuole.

most striking characteristic. Two common members of the group are *Stylonychia* (Fig. 29, C) with its dumb-bell-shaped macronucleus and two micronuclei and *Kerona* which may often be observed running up and down on the surface of *Hydra* (see p. 87).

IV. PERITRICHA. Here the ciliary coating is still more reduced—there being only a spiral of ciliary plates round the edge of the peristome with sometimes a circle of small cilia in addition. A well-known example is *Vorticella* (Fig. 29, B)—the Bell animalcule—which may often be found attached to freshwater plants. The general shape is that of a bell—the handle prolonged into a slender **stalk** by which the creature is attached

and the mouth occupied by a slightly convex **disc**, surrounded by a groove deepened at one point into a funnel-shaped recess (the **vestibule**) which is continued down into the gullet and into which opens the anus. Disc, groove and vestibule make up the peristome, and the row of cilia runs round the disc and down into the vestibule round which it twists in the form of a continuous undulating membrane like that in the gullet of *Paramecium*. The macronucleus of *Vorticella* (Fig. 29, B, N) is elongated and is usually bent into a more or less horse-shoe shape, and there is a single small micronucleus (*n*). A contractile vacuole is present (*c.v*) which empties itself into a little pocket-like recess in the wall of the vestibule—the reservoir.

The *Vorticella* is extremely sensitive and at the slightest shock the body contracts to a spherical shape the disc being drawn down and the outer lip of the surrounding groove contracting over it while the stalk becomes coiled into a close spiral. As in the case of *Stentor* contraction is brought about through the agency of highly developed myonemes. In the stalk when extended a single myonemic band may be seen running throughout in a spiral course; when this contracts it tends to straighten and the stalk containing it assumes on the contrary a spiral twist.

Another member of the Peritricha should be mentioned as it may be observed by the student during his work on *Hydra*. This is *Trichodina*, a curious disc-shaped ciliate which occasionally may be seen gliding about on the surface of a *Hydra*. Like *Kerona* it is found only as a parasite of *Hydra* and other aquatic animals.

ACINETARIA

As an appendix to the Ciliata may be mentioned the group ACINETARIA or Suctorina, comprising creatures which have given up the actively moving habit and have undergone characteristic modifications in correlation with their sedentary mode of life.

The typical Acinetarian (Fig. 30, A) consists of a mass of protoplasm, commonly pear-shaped or in the form of a somewhat triangular disc, attached to the solid substratum by the narrow end which is more or less prolonged to form a stalk. The complex structure of the ectoplasm seen in the typical actively moving ciliate has disappeared. At the attached end the ectoplasm is connected with the substratum by secreted material—which may be looked on as ectoplasm that has lost its organized structure—and it is this which may take the form of a long stalk. In some cases the material of the stalk is continued upwards so as to

form a kind of cup enclosing and protecting the greater part of the body of the creature. In the endoplasm are the nuclear apparatus (macro- and micronucleus) and contractile vacuole as in ordinary Ciliates.

In the sedentary Acinetarian the cilia have disappeared but there are present other projections of the protoplasm which constitute its most characteristic feature: these are the **sucking tubes**. Each of these, which looks like an extremely slender pin projecting from the body, is really a very fine straight tube with a slightly expanded trumpet-shaped end (Fig. 30, *t*). The wall of the tube is a prolongation of the stiff ectoplasm while the interior contains fluid. The tubes vary in

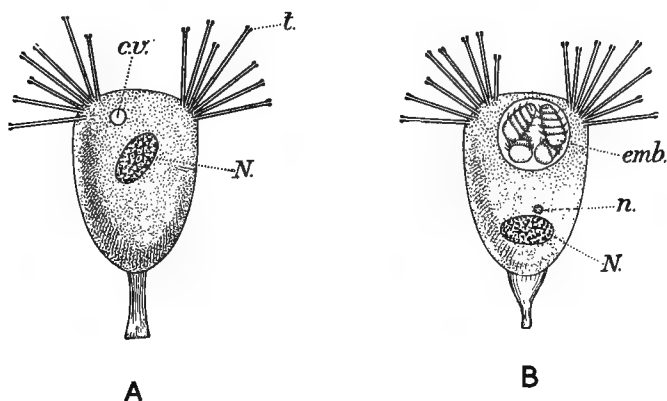

FIG. 30.

Acinetaria. A, *Tokoparyia*; B, *Acineta*, showing young ciliated stage. *c.v.*, Contractile vacuole; *emb.*, embryo; *N*, macronucleus; *n*, micronucleus; *t*, suctorial tube.

number in different Acinetarians from one up to a large number, when many are present they may be either scattered irregularly or as in the genus *Acineta* collected into clumps.

The function of the sucking tubes is seen if a small Ciliate knocks up against them. It adheres to the end of the tube and its protoplasm is gradually sucked down through the tube into the endoplasm of the Acinetarian where a food-vacuole forms round it and it is gradually digested.

That the conclusion which may be drawn from the presence of the characteristic Ciliate type of nucleus that the Acinetaria are modified Ciliates is correct is shown by the study of their life-history—for the young stage is provided with cilia and swims about like an ordinary Ciliate. The young creature arises as a kind of bud, as a projecting piece

of the parental body which projects either outward from the free surface or inwards into a special brood-cavity in which it remains for some time before being set free (Fig. 30, B).

Again the process of syngamy in the life-history of the Acinetaria agrees closely with that of the typical Ciliata.

It is interesting to note that some of the Acinetarians have taken on a parasitic mode of life: sometimes they are parasitic in the adult condition on Hydroids (*Ophryodendron* on Marine Hydroids); more commonly the young stage alone is parasitic, burrowing in some cases into the body of other Acinetarians (*Tachyblaston* in *Ephelota*). An intermediate step towards the parasitic condition is shown by numerous genera whose habit is epizoic, i.e. which live attached simply to the surface of other aquatic animals such as Hydroids, Crustacea, etc., without actually absorbing nourishment from them.

Before leaving the subdivisions of Protozoa it is necessary to glance at two groups of organisms the relationships of which are rather uncertain but which have come into prominence of recent years in connexion with the causation of disease.

THE SPIROCHAETES

The first of these includes a variety of creatures which may be called by the general name Spirochaetes. These resemble somewhat in general appearance very slender Trypanosomes and although formerly grouped together as one genus *Spirochaeta* are now usually subdivided among a number of separate genera. For the sake of simplicity we shall here adhere to the older practice—mentioning parenthetically the newer generic names.

A spirochaete is as already indicated somewhat like a very slender and usually very minute trypanosome. The thread-like body shows in the dead specimen a number of undulations from side to side but owing to the minute size it is difficult to be certain as to whether these are merely bends from side to side as in a trypanosome or, as is more probable, the turns of a cork-screw spiral. When alive the movements are very characteristic, the spirochaete swimming rapidly in the direction of its length for a short distance and then reversing its movement.

It is again difficult to make sure whether this movement consists, like that of a trypanosome or an eel, of movements of flexure from side to side, or merely of a rotatory movement of the spiral about its long axis.

There does not appear to be any concentration of the particles of nuclear material, which are scattered throughout the body, to form a definite nucleus. Reproduction takes place so far as is known simply by transverse fission.

The first Spirochaetes to be discovered and described—so far back as 1833 (Ehrenberg)—were free living creatures but the species of greatest practical interest have taken on a parasitic mode of life. One group of these (*Cristispira*) are found in the alimentary canal of Oysters and other Pelecypoda (p. 267) and being of relatively large size and easily obtainable are especially convenient for laboratory study. They may be nearly always found in the “crystalline style” of freshly collected specimens of the common fresh-water mussel (*Anodonta*).

Of special human interest are the spirochaetes—of very minute size—which live as parasites in the body of man and other vertebrates. Certain of these (*Spiroschaudinna*) inhabit the blood and cause fever, e.g. in fowls and geese or in man. In man the disease produced is the well-known Relapsing or Intermittent Fever which occurs in various parts of the world.

The common relapsing fever of tropical Africa is associated with the presence, in the blood, of *S. duttoni*—a spirochaete measuring about 14 μ in length. Infection is carried by a species of Tick—*Ornithodoros moubata*—common in huts and camping grounds. When infected blood is swallowed by this animal the spirochaetes instead of being digested multiply rapidly and spread throughout its body. The infected tick apparently does not inoculate the spirochaetes into a new individual directly by its bite as one might expect. What happens is that excretory material containing spirochaetes exudes from its anal opening and, spreading over the surface of the skin, gets into the wound.

Amongst other tissues the eggs of the tick are penetrated by spirochaetes, with the result that the young ticks of the next generation are infected and are capable both of causing infection themselves and of passing on the infectivity to their progeny.

The type of Relapsing Fever once common in Western and still occurring in Eastern Europe is brought about by the presence of a different species of spirochaete (*S. recurrentis* or *obermeieri*) which may be distinguished from *S. duttoni* by its smaller size (7-10 μ). Observations carried out in Northern Africa on what appears to be the European type of Relapsing Fever have shown that the infective agents here are not Ticks but Lice. When the louse has ingested infected blood the spirochaetes gradually disappear from its alimentary canal and at the end

of 24 hours are no longer to be detected. However they again make their appearance after an interval of about eight days and are to be found in abundance up till about the nineteenth day all through the haemocoel or body cavity of the louse. From about the nineteenth day the spirochaetes undergo a gradual reduction in numbers until apparently they eventually disappear completely and finally. It is during the period mentioned (eighth to nineteenth day) that infection is liable to be conveyed—not by the bite of the louse, but only in the event of its body being crushed and its infected blood rubbed into a scratch or coming in contact with some part of the skin, such as that covering the surface of the eyeball, through which the spirochaetes are able to make their way.

Spiroschaudinmia icterohaemorrhagiae is the microbe of epidemic jaundice. It is apparently normally a parasite of the Rat, passing away in the urine and infecting wet soil from which it gains access to the human body either directly through the skin or by being swallowed.

The last type of spirochaete to be mentioned (*Treponema*) is that which is the causative agent of the human diseases Syphilis and Yaws.

The parasite of Syphilis (*T. pallida*) was discovered by Schaudinn in 1905 and is a minute spirochaete averaging about 7μ in length, the body tapering off at each end into a delicate flagellum-like extension. It is transmitted directly from one individual to another by intimate contact without the intervention of any intermediate host. It multiplies rapidly and invades all parts of the body including the reproductive cells, or embryo if present in the uterus, so that the offspring when born is already infected.

The tropical skin disease known as Yaws or "Framboesia tropica" is believed also to be due to a spirochaete (*T. pertenue*, discovered by Castellani) closely resembling the spirochaete of syphilis. Infection takes place by direct contact, the parasite gaining entrance to the body through any small abrasion or wound of the skin.

Spirochaetes are by no means restricted in man to the specific diseases that have been mentioned. They are common inhabitants of the mouth and in the septic condition of the gums known as Pyorrhoea alveolaris are found in enormous numbers and in great variety, as may be gathered from Fig. 31.

Various of the spirochaetes are of very minute size, and in this connexion an important observation was made by Schaudinn the discoverer of the parasite of syphilis. He found in the excretory tubes of mosquitos spirochaetes which reproduced so rapidly by fission that the ultimate

products were no longer individually visible even under the highest powers of the microscope. The practical interest of this is in connexion



FIG. 31.

Preparation from a bad case of *Pyorrhoea alveolaris* as seen under very high magnification, showing spirochaetes of various species as well as other organisms (after Drew and Griffin). 1, 2, Flagellates; 3-7, Spirochaetes (3, *S. biccatis*; 4, *Treponema vitreum*; 5, *T. microdentatum*; 6, *T. microdentatum*; 7, *S. refringens*); 8, various Bacteria; 9, *Leptothrix* (vegetable) filaments. [Two specimens of *Entamoeba gingivalis* are also visible.]

with diseases due to "invisible germs." Thus Yellow Fever has been proved to be due to a germ: the germ has never been seen but yet it has been roughly measured, for by filtering infected fluid through a

series of porcelain filters of graduated degrees of fineness it can be determined that the germs, as indicated by the infectivity of the fluid, pass through the pores of one particular filter of the series while they are stopped by the next. Lastly it has been shown that the transmitting agents of the disease are mosquitos of the genus *Stegomyia* (p. 250), which if allowed to bite a patient during the first three days of the disease become about twelve days later capable of inoculating the disease into a new individual. Schaudinn's observation then gives a clear hint as to the advisability, in investigating such a disease as Yellow Fever, of bearing in mind that the culprit organism may be a minute spirochaete and that it may be found to lurk in such unexpected nooks in the mosquito's body as the excretory tubes.

Along with Yellow Fever in this connexion we may bracket Dengue Fever and Pappataci Fever. The former—a widely distributed disease in warm regions—is transmitted by mosquitos, including the species responsible for Yellow Fever. Pappataci or Sand-fly Fever, a common fever in the countries round the Mediterranean, is spread by the small Midge or Sand-fly *Phlebotomus*. If this fly takes in infected blood from a patient during the first 24 hours of an attack it becomes after an interval of from seven to ten days itself capable of passing on the infection.

CHLAMYDOZOA

A number of diseases (*e.g.* Smallpox, Scarlet Fever, Hydrophobia, Trachoma, Foot and Mouth disease), affecting especially the ectodermal tissues (p. 129) and apparently also due to microbes so minute in size as to pass through ordinary bacterial-filters, are characterized by the presence within the cells of curious rounded inclusions the staining reactions of which resemble those of achromatic nuclear material. These bodies have been given by pathologists different names in the different diseases in which they have been observed—Guarnieri's bodies, Mallory's bodies, Negri's bodies, Prowazek's bodies and so on—and they have been interpreted as being intracellular parasites of protozoan nature. There is a general tendency now however to regard these bodies not as actual parasites but as being material formed by the host-cell in response to the disturbing effects of parasites. The actual parasites on this view are minute rounded dot-like objects which may be observed within the cell-inclusions. That these are living organisms is indicated by their frequently being observed in process of division into two, going through a dumb-bell-shaped stage. As these bodies tend to become enclosed in a sheath (the cell-inclusion) they have been given the name CHLAMYDOZOA and they are

regarded by many as being the actual causal agents of the disease. Regarding the details of their structure and life-history we are still ignorant.

PROTOZOA AND DISEASE

In the course of this chapter various protozoan parasites have been mentioned as the causative agents of harmful diseases of man and other animals, and the student is apt to get into the habit of thinking of such parasitic protozoa as being necessarily and naturally associated with disease. As a matter of fact however there is reason to believe that the production of disease is by no means a natural characteristic of such protozoan parasites: disease is caused rather when the parasite finds itself in some host other than that which is normal to it.

When some particular species of protozoan parasite is introduced into the body of a host animal this latter may behave towards the parasite in any one of three different ways.

I. It may show itself to be **repellent**: the intruding organism is rapidly killed and destroyed.

II. It may show itself to be **tolerant** towards the particular type of parasite: the latter continues to live and reproduce but without increasing to such an extent as to cause perceptible interference with the health of the host.

III. It may show itself to be **susceptible**: the parasite not only lives and multiplies but it increases to such an extent as to upset to a less or greater extent the normal living activities of the host—in other words it produces disease.

Now under natural conditions, individuals or strains of individuals which are in any degree susceptible towards such protozoa as are liable to be introduced into their blood, are through this handicap being constantly eliminated in the intense struggle for existence. Consequently we find in Nature that the vast majority of individual animals in any particular locality show little or no susceptibility towards such protozoa of that neighbourhood as are likely to gain access to their bodies: they are either tolerant or repellent towards them.

It will be readily understood that the development of tolerance on the part of the host will be helped by Nature acting on the parasite—for it is clearly to the advantage of the parasite that it should be able to live within the body of the host without causing its disease or death. Strains of parasites will tend to flourish and increase in proportion as they are readily tolerated by the host, while strains of parasites towards which a particular species of host animal is markedly susceptible will stand a

much poorer chance of persisting as a parasite of that particular host animal.

While there thus comes about in Nature a kind of equilibrium between the host animals and the parasites of a particular region that equilibrium is liable to be upset by (a) the introduction of new host animals into that region, or (b) the introduction of new parasites. There are then brought into contiguity with one another hosts and parasites between which Nature has had no time to bring about the elimination of susceptibility and there are now liable to occur violent outbreaks of disease, lasting until the particular species of host animal is completely exterminated or on the other hand, a condition of tolerance or repulsion has been gradually brought about by the weeding out of the more susceptible and the survival of the less susceptible strains.

Such disturbances of equilibrium occur doubtless frequently in Nature but particularly striking examples have come about through the action of man.

The white man colonizes parts of the world infected by the parasite of Malaria and he suffers greatly from the attacks of the malarial parasite towards which the aboriginal negro inhabitants have become tolerant, while continuing to act as carriers or reservoirs of the disease. Again he introduces domesticated animals into regions in which they fall victims to epidemics of Trypanosomiasis or Piroplasmosis caused by parasites which spread to them from the native animals in which they live without causing any obvious disease.

Or again it may be the parasite rather than the host which is transported into unaccustomed regions. Such seems to have been the case with sleeping sickness, which has long existed on the West Coast of Africa but which, conveyed up the course of the Congo by carriers, developed among the natives of Uganda into an epidemic of the greatest violence as compared with the comparatively feeble outbursts on the West Coast where susceptibility had been in the course of time gradually diminished.

BOOKS FOR FURTHER STUDY

I. GENERAL TEXT-BOOKS

Minchin. Introduction to the Study of the Protozoa.

Doflein. Lehrbuch der Protozoenkunde.

II. SYSTEMATIC WORK FOR THE IDENTIFICATION OF
FREE-LIVING PROTOZOA

Kent, Saville. Manual of the Infusoria.

III. BOOKS DEALING WITH PARASITIC PROTOZOA

Brumpt. Précis de Parasitologie.

Manson. Tropical Diseases.

Castellani and Chalmers. Manual of Tropical Medicine.

CHAPTER II

METAZOA—INTRODUCTORY REMARKS

IN the phylum Protozoa we had to do with single cells living independently. The individual cell multiplies from time to time, by fission or otherwise, but the cells so arising separate and lead an independent existence like the parent. In all the members of the animal kingdom outside the Protozoa—commonly grouped together under the name METAZOA—the life-history commences with a stage in which the individual is a single cell—a zygote—which as in the case of the Protozoa multiplies by a process of fission repeated over and over again, but in this case the successive generations of cells produced by the process of fission do not break apart and lead an independent existence. On the contrary they remain as a coherent mass of cells which, in correlation with the repeated fission of its component cells, exhibits growth in size. Just as in the case of the Protozoa, the process of fission slackens off in due course, so that the cell-mass does not increase in size indefinitely but merely attains to a more or less definite full-grown size. This mass of cells forms the body of the Metazoon, an individual of a higher order than the cell-individual seen in the Protozoa, for it is composed of a mass of cells which cohere together and have their individualities merged in that of the whole.

In a typical simple Protozoon the cell-individuals are unspecialized; each is just like its forebears. In the body of the Metazoon on the other hand the successive generations of cells which come into existence during the building up of the fully developed body become more and more specialized: they gradually lose the primitive unspecialized character of their zygote ancestor and, with the loss of the unspecialized ancestral character, they lose for the most part their capacity for conjugating in a process of syngamy with other cell-individuals. At one or more points in the body however there remain nests of cells which do not become side-tracked on any path of specialization for particular

functions but which, as they go on multiplying by fission, retain the ancestral unspecialized character and with it the capacity for conjugation. These cells, whose function it is to provide the living substance for subsequent individuals, form collectively what is known as the **gonad**, while the remaining, much larger, portion of the body forms what is termed the **soma**. A highly important point to realize about the living substance of the gonad is that so far as we know it is without that great characteristic of most living substance that in due course it dies a natural death. Any piece of the gonad may in the process of syngamy be passed on to a new individual, and this may be repeated so far as we know through an unlimited number of generations, so that the substance of the gonad is potentially immortal. Of course by far the greater part of it is not in practice actually immortal, for it is dependent for its existence upon the soma in which it lives and when this dies it suffers what may be called an accidental death.

The body of the Metazoon, composed as it is of myriads of cells, reaches a relatively enormous size, and the specialization characteristic of the somatic cells is intimately linked up with needs imposed by this great increase in size. To support the soft semi-fluid living protoplasm, and prevent it from collapsing into a shapeless mass, portions of the cells, or masses of whole cells, are specialized to form hard supporting substance or **skeleton**. To enable the individual to move, certain tracts of cells in immediate relation to the parts of the skeleton are specialized for contractility, forming the **muscles**. To deal with impressions from the outer world, to bring about appropriate movements through the muscular system, and in general to control the various living activities, the several regions of the body are linked together by the **nervous** system. The outer surface of the body—through which the minute Protozoon takes in its nourishment, gets rid of its waste products, and carries out its respiratory exchange of gas with the surrounding medium—becomes hopelessly inadequate to carry out these indispensable functions in the bulky Metazoon, and in consequence we find three other important developments. An increase of surface for the taking in of nourishment (and the getting rid of faecal material) is obtained by a part of the surface being prolonged into the interior of the body in the form of a more or less tubular **alimentary canal**. A system of finer tubes or vessels arises, through which nourishment and oxygen are distributed to the various tissues of the body and carbon dioxide and other waste products carried from them—the **blood** system or **vascular** system. Another system of tubular channels are developed, the walls of which have for their special function the extracting of the poisonous waste products from the blood and the

passing them away to the exterior—the **renal** or **nephridial** system. And finally there exist in the bodies of most Metazoa hosts of permanently mobilized **amoebocytes**—cells which retain a more or less amoeboid character, which are able to creep about actively and to attack, and either destroy or transport to a position in which they are harmless, noxious particles which have found their way into the body such as for example invading microbes.

The individual cell of the Metazoon, just as the whole individual Protozoon, may be said to be aquatic in its habit, for in order to live it has to be in contact with watery fluid. The whole body then of the Metazoon is permeated, all its intercellular chinks are filled, by watery fluid, forming an **internal medium** just as the water forms the external medium for a free-living Protozoon. This internal medium however is vastly more complex in chemical composition than ordinary water, for into it are discharged the various products of the metabolism of the living protoplasm. Just as the myriads of cells which constitute the body show obvious specializations of form and structure, so also there exist less obvious peculiarities in their metabolism. Consequently the substances which find their way into the internal medium from the various types of cell are by no means identical but have their own special peculiarities. These various substances, contributed each in its normal proportion, constitute, with the water into which they are discharged, the enormously complicated internal medium of the body. Every living cell in a particular species of animal is adapted to life in an internal medium of specific composition, and if any particular organ or tissue fails to contribute its quota, or contributes it in abnormal proportion, then the resulting abnormality in composition of the internal medium is apt to have harmful—it may be disastrous—effects on the health of the whole body.

COELENTERATA

SCHEME OF CLASSIFICATION

I. HYDROZOA.

A. Hydrida.

B. Hydromedusae.

(1) Gymnoblastera (Anthomedusae).

(2) Calyptoblastera (Leptomedusae).

C. Acalephae.

II. ACTINOZOA.

A. Alcyonaria.

B. Zoantharia.

The simplest members of the Metazoa, in which most of the peculiarities mentioned above as characteristic of the typical Metazoa have not yet made their appearance, constitute the phylum Coelenterata. Amongst these in turn some of the very simplest are the HYDRIDA exemplified by the genus *Hydra*.

HYDRA

Hydra is the common little "fresh-water polyp" which inhabits ditches, ponds, lakes, all over the world.

When in its normal condition (Fig. 32, A) it is tubular in form—one, closed, end of the tube adherent to some solid object such as a water-plant or stone, the other with a minute pore—the mouth (M)—situated at the apex of an **oral cone**. The mouth is closed and practically invisible except when it is distended during the taking in or rejection of food material. Round the base of the oral cone are attached about six to eight delicate threadlike (really tubular) **tentacles** (Fig. 32, A, *t*). To study the structure of the Hydra in detail it is necessary to treat specimens with some substance such as Acetic acid which will loosen the cohesion of the cells and allow them to be broken apart by tapping on the

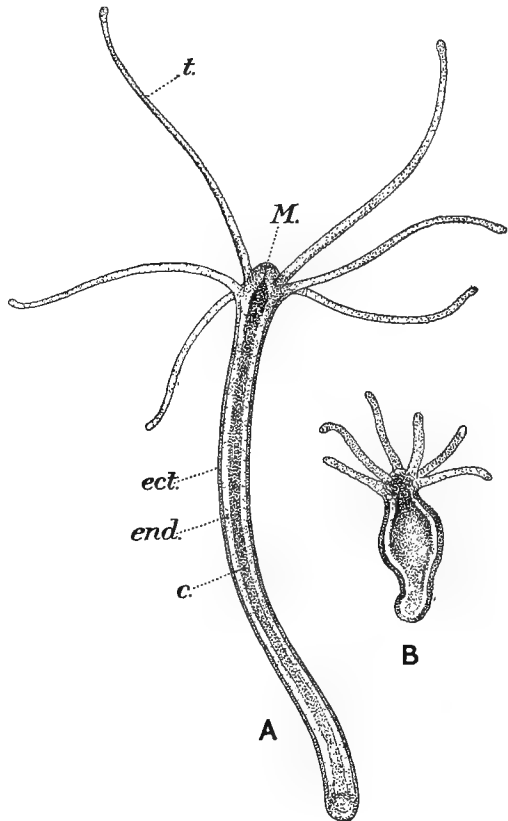

FIG. 32.

Hydra. $\times 12$. A, Partially extended; B, contracted. (From Graham Kerr's *Primer of Zoology*.) *c*, Coelenteron; *ect*, ectoderm; *end*, endoderm; *M*, mouth; *t*, tentacle.

of the cells and allow them to be broken apart by tapping on the

coverslip, and to cut other specimens into fine slices or **sections** for examination under the microscope.

The Hydra as already indicated is tubular, its cavity (Fig. 32, A, *c*) being known as the **coelenteron**. The coelenteron communicates with the exterior at the mouth: it extends up to the tip of each tentacle where it ends blindly. The coelenteron is surrounded by the body wall consisting of two layers of cells, an outer **ectoderm** (Fig. 32, A, *ect*) and

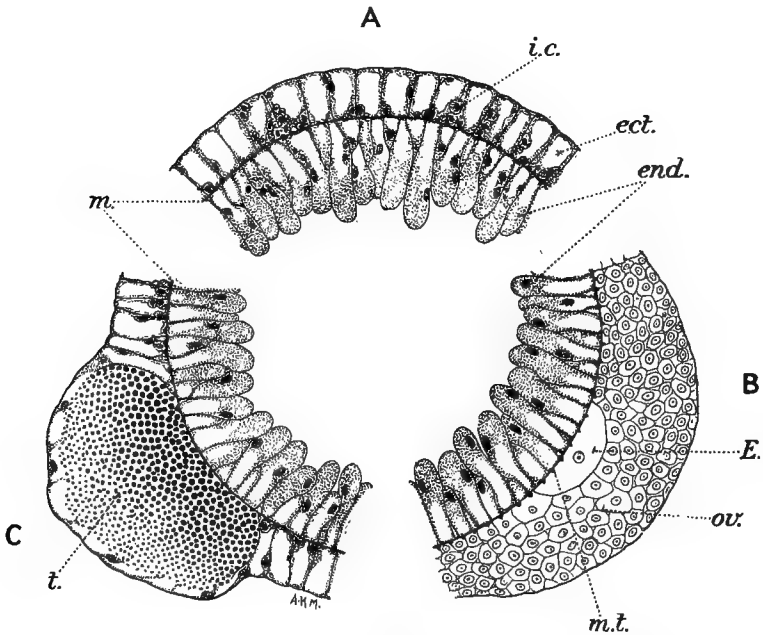

FIG. 33.

The structure of *Hydra* as seen in transverse sections. $\times 150$. A, Normal structure; B, early stage of ovary; C, testis. *ect.*, Ectoderm; *E.*, egg; *end.*, endoderm; *i.c.*, interstitial cells of ectoderm; *m.*, mesogloea; *m.t.*, muscular tail of ectoderm cell, lying in close contact with mesogloea and seen here in transverse section; *ov.*, ovary; *t.*, testis.

an inner **endoderm** (*end.*), separated by an apparently structureless membrane—the **mesogloea** (Fig. 33, A, *m.*). The ectoderm (Fig. 33, A, *ect.*) is in great part made up of tall columnar-shaped cells which taper off towards their inner ends and there pass into two tail-like prolongations which being in line with one another resemble the crosspiece of a letter **T** (Fig. 34, A). This crosspiece is in great part composed of protoplasm which, like the myoneme of a Protozoon, is specialized in the direction of extreme contractility.

A layer of cells arranged side by side is what is technically known as an **epithelium**. A cell of the type just mentioned is termed a **myo-epithelial** cell, for not only does it form with its neighbours an epithelium, but in the presence of its contractile tail it represents an early stage in the evolution of a muscle-cell. In the case of the ectoderm the myo-epithelial cells are so arranged that the contractile tails run lengthwise, so that when they contract the Hydra shrinks up into a short squat form (Fig. 32, B). The tails lie in close contact with the outer surface of the mesogloea and in transverse sections under a very high magnification they look like irregular tags projecting from the mesogloea (Fig. 33, *m.t.*). The myo-epithelial cell of the ectoderm (Fig. 34, A) is normally almost filled by a large fluid vacuole, the protoplasm being so distended as to form merely a thin wall surrounding the vacuole and containing the nucleus embedded in its substance. At the extreme outer end of the cells the protoplasm is slightly condensed so as to form a protective **cuticle** over the external surface of the Hydra. On the flattened base of the Hydra the myo-epithelial cells are without cuticle and in place of a large fluid vacuole their protoplasm contains numerous droplets of secreted material—a sticky cement which is extruded at the outer end of the cell and helps to attach the Hydra to the substratum. Here we for the first time meet with a **gland-cell**—a cell specialized for the formation of some particular substance or **secretion** which is passed out from the body of the cell to serve some particular function.

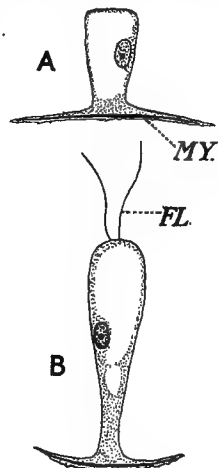

FIG. 34.

Isolated myo-epithelial cells of *Hydra*. A, From the ectoderm; B, from the endoderm. (From Graham Kerr's *Primer of Zoology*.) FL, Flagellum; MY, contractile strand.

The spaces between the tapering inner ends of the myo-epithelial cells are occupied by comparatively undifferentiated rounded **interstitial cells** (Fig. 33, *i.c.*). These are cells which have remained as it were in a young condition, not having developed the various peculiarities characteristic of the myo-epithelial cell. Certain of these cells are destined to give rise to very remarkable cells termed **cnidoblasts** which play an important part both in defence and in the capture of food.

The fully developed cnidoblasts are most numerous in the tentacles. Each (Fig. 35, A) is a somewhat oval-shaped cell prolonged into a stiff protoplasmic hair called a **cnidocil** (*cn*) which projects freely beyond

the surface of the tentacle into the surrounding water. The most remarkable feature of the cnidoblast is the **nematocyst** (*nem*) which fills up a great part of its interior. This is a hollow flask or bulb the neck of which tapers off into an extremely fine tube open at its free end (Fig. 35, C). Round the neck of the bulb are arranged three sharp blades. In the nematocyst as observed within the cnidoblast the fine tube, including the neck with its blades, is turned outside in and lies in the interior of the bulb, the tube being coiled up into a spiral. The rest of the cavity of the bulb is filled with fluid, apparently of a virulently poisonous kind.

Besides the cnidoblasts such as that which has been described there exist others, more numerous, smaller in size

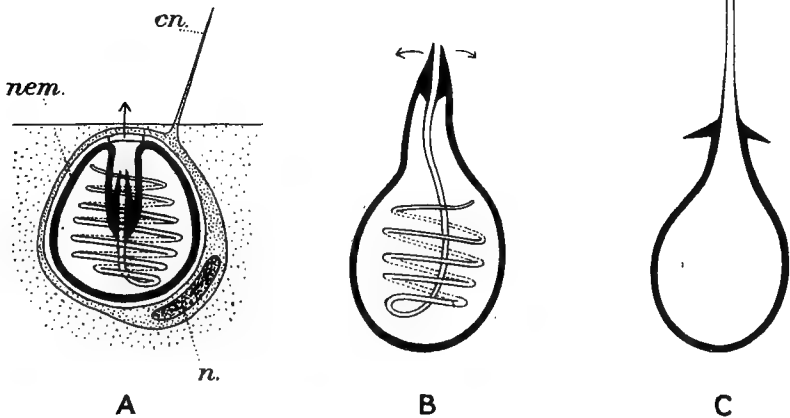

FIG. 35.

Cnidoblast and nematocysts. A, Unextruded; B, early stage of extrusion; C, extrusion complete. *cn*, Cnidocil; *n*, nucleus; *nem*, nematocyst.

and containing nematocysts of slightly different shape and unprovided with blades.

The cnidoblasts are originally interstitial cells which gradually form the nematocyst in their interior. They then creep away from their point of origin, usually though not always into the tentacle, burrow their way into the substance of an ordinary ectoderm cell and there settle down, pushing their cnidocil beyond the surface of the host cell into the surrounding water. In a normal ectoderm cell of the tentacle there is usually a group or battery of cnidoblasts, a larger one in the centre and a circle of smaller ones round it.

The nematocyst is a powerful offensive organ. If any small organism swimming through the water blunders up against the cnidocil this acts like a trigger and causes the nematocyst to discharge, the thin tube being violently everted so as to pierce the body of the organism, an opening being made for it by the three blades as they swing outwards. The movements of the animal pierced by the nematocyst, at least if it be small, are paralysed—and it is assumed that a virulent poison is injected through the tube.

As regards the mechanism by which the explosion is brought about, a hint is got from the fact that nematocysts which have been freed from their cnidoblast commonly explode instantly when they come in contact with water. This suggests that the fluid within the nematocyst is of such a nature as to cause very rapid diffusion of water inwards through the nematocyst wall if this is in contact with water, the increased pressure so set up bringing about the discharge of the nematocyst. Possibly what happens is that on the cnidocil being touched the protoplasm of the cnidoblast shrinks back and exposes the outer surface of the nematocyst to the action of the water.

The cells which constitute the gonad of *Hydra* are also derived from interstitial cells. The gametes show well-marked sexual differentiation; the portions of gonad which give rise to the small actively motile microgametes are termed **testes**, those which give rise to the large non-motile macrogametes or eggs are termed **ovaries**. The testes when present are in the form of conical or rounded thickenings of the ectoderm, varying in number and most usually situated towards the upper end of the Hydra: the ovaries, fewer in number, are spherical in shape and are situated rather towards the basal end. Hydra is **hermaphrodite**, i.e. the same individual may develop both ovaries and testes, but as a rule the ovaries develop later than the testes.

The study of sections shows that the young gonad is formed by a heap of actively multiplying interstitial cells. In the case of the testes (Fig. 33, C) they keep on multiplying until there are formed enormous numbers of minute round cells each of which becomes a slender microgamete with a long vibratile tail and a small rounded "head."

The earliest stages in the development of the ovary are precisely like those of the testis but presently a few cells begin to grow rapidly in size at the expense of the others. One of these (Fig. 33, B, E) eventually shoots ahead of the others, ingesting the bodies of its neighbours in Amoeba fashion, and not merely grows to a relatively enormous size but in later stages loads up its cytoplasm with reserve food material or yolk. This cell after it has undergone a process of maturation by the

formation of two polar bodies (see below, p. 185) constitutes the macrogamete.

The endoderm of the Hydra, even in the living specimen examined as a whole under a low power of the microscope, shows a striking difference from the ectoderm in that it is distinctly coloured, green or brownish according to the species, whereas the ectoderm is colourless. The endoderm (Fig. 33, A, *end*) is composed mainly of a layer of myoepithelial cells (Fig. 34, B) considerably larger than those of the ectoderm and differing from them also in other details. The muscular tails are arranged not longitudinally but circularly, so that when they contract they cause the Hydra to assume an attenuated threadlike form, increasing greatly in length. The end of the cell next the coelenteron is rounded and in many cases carries flagella (Fig. 34, B) which by their constant lashing cause food and other particles to be swirled about in the fluid of the coelenteron. In a Hydra which has been starved the endoderm cells contain large vacuoles. In a well-fed specimen on the other hand these are inconspicuous while there occur scattered about in the protoplasm numerous deeply staining **protein-spheres**—composed of stored-up food material—while there are also present clumps or isolated granules of brown excretory substance.

Amongst the ordinary endoderm cells there occur, especially in the region of the oral cone, occasional gland cells—squat-shaped cells, without muscular tails, and containing droplets of secretion in their cytoplasm.

As regards the physiology of the Hydra we have to notice first its process of feeding. A small food organism such as a Water-flea caught and paralysed by the nematocysts of the tentacles is drawn to the mouth, which opens to receive it, and slowly passed into the coelenteron. In the latter its digestible portions gradually disintegrate under the influence of digestive ferments passed into the cavity by the gland cells. Here we have a process of digestion taking place not within the substance of a cell (intracellular), as was the case in the Protozoa, but in a space bounded by cells (intercellular), the dissolved products of digestion being absorbed by the cells bounding the space. The process of digestion throughout the Metazoa is for the most part intercellular. In the case of *Hydra* however there still persists a certain amount of intracellular digestion, for fragments of disintegrated food are ingested bodily by the inner ends of the endoderm cells and their digestion completed within the cytoplasm of the cell.

In the case of the green Hydra the endoderm is infested with numerous symbiotic chlorophyll-containing Flagellates to which the bright green

colour is due, and in correlation with this the animal seeks the light necessary to the functioning of the chlorophyll, while the brown Hydroids seek rather the shade.

The movement of the Hydra from place to place may be a slow gliding movement carried out by small pseudopodia pushed out by the ectoderm cells of the base, or a more rapid movement in which the Hydra attaches itself by similar pseudopodial extensions of the ectoderm cells of its tentacles while it temporarily detaches its basal end from the substratum to re-attach itself elsewhere.

When living under favourable circumstances and well supplied with food the Hydra multiplies actively by an asexual process of **budding**. A little pocket-like outgrowth comes to project from the body, it increases in size and gradually takes on the form of a small Hydra, a circle of tentacles sprouting out from its end and a mouth perforation developing between them. Finally it becomes constricted off at its base as an independent Hydra just like the parent except that it is smaller in size. When the budding process is very active a number of buds may be present on the parent at one time, and the buds may have secondary buds sprouting out from them so that there is formed a continuous mass of Hydra individuals forming a sort of colony. Such a condition however is only temporary and before long the mass separates into its constituent individuals which proceed to lead a free independent existence.

Budding is not the only method by which the Hydra is capable of multiplying asexually. Occasionally—though very rarely—it may be observed to reproduce by fission, the Hydra dividing lengthwise into two, the process commencing at the oral end and slowly spreading downwards towards the base.

After a more or less prolonged period during which the multiplication of the Hydra is entirely asexual there comes a time when gonads make their appearance—the season differing in different species of *Hydra*. Probably we may safely say that the appearance of the gonads is associated with the onset of conditions in some way unfavourable to the life of the particular species.

The fully developed ovary forms a conspicuous rounded mass projecting from the body of the Hydra, its interior filled by the large spherical egg or macrogamete. The testis forms a rather more pointed projection of a whitish colour. When fully developed, examination with the high power of the microscope shows a wild commotion going on in its interior, due to the active movements of the microgametes. Eventually the wall of the testis ruptures and the microgametes disperse through the water. The overwhelming majority are wasted—this is a general characteristic

of male gametes—but if one reaches an ovary containing a ripe macrogamete, it penetrates this and syngamy takes place.

The zygote or fertilized egg now proceeds to undergo the process of **segmentation**—consisting of fission repeated over and over again. This results in the formation of a **blastula**—a mass of cells forming a sphere and arranged in a single layer round a central cavity. As development proceeds cells derived from the cells of the wall drop into the cavity and eventually fill it. The mass of cells, or the embryo ¹ as we now call it, is at this stage solid and consists of two distinct layers of cells—those which formed the wall of the blastula and those which fill its cavity. These are the two primary cell-layers of the individual—the ectoderm and the endoderm.

The embryo now comes to be enclosed in a protective chitinous shell, secreted by the ectoderm and differing in appearance in different species of *Hydra*. It drops off the parent and remains in the mud at the bottom of the water for it may be a prolonged period until conditions again become favourable. When this happens the embryo, apparently by the secretion of a digestive ferment to soften the shell, makes its way out and gradually develops into a typical small Hydra.

HYDROMEDUSAE

It is instructive to compare with *Hydra* those animals grouped together under the name HYDROMEDUSAE, in which the life-history is somewhat more complicated than it is in *Hydra*. It is also a characteristic feature of this group that while asexual reproduction by budding takes place the individuals so arising do not as a rule become separate but remain throughout life connected together in the form of a community or colony.

OBELIA

A good illustrative example of the Hydromedusae is the common marine genus *Obelia*. To the naked eye a colony of *Obelia* looks like a bit of whitish thread creeping over the surface of a seaweed or stone or shell and giving off at intervals little branches which project freely into the water. Each of these branches can be seen with a magnifying lens to be bent in a characteristic zigzag manner and to give off from the outer

¹ An embryo is a young developing individual, which is contained within the body of the parent or within a protective shell or other envelope. A larva is on the other hand a young developing individual, differing in form from the adult, but *not* contained within the body of the parent or other protective envelope.

side of each bend what looks like a tiny conical sherry-glass mounted on a stalk (Fig. 36, *h*). In this conical receptacle there resides an individual of the colony—a **polyp** or **hydroid** individual, so called because in the main features of its organization it agrees with *Hydra*. The body wall is composed of the same layers as in *Hydra*; there is a large oral cone with a wide mouth (Fig. 36, *o.c.*), and a ring of tentacles like those of *Hydra* except that they have a solid core of much vacuolated endoderm cells, the coelenteron not extending into them. The body of the polyp is continued downwards as a tube composed of the same layers and this in turn joins the thread-like **stolon**—similar in structure—similar in structure—which meanders over the surface of the stone or seaweed.

The cuticle is greatly developed in *Obelia* forming a thick horny protective layer—the **perisarc** (Fig. 36, *ps*). This covers the whole surface of the colony and its branches. At the base of the polyp the perisarc loses its intimate contact with the cells of the ectoderm and expands to form a wide cup—the **hydrotheca**—which surrounds the polyp (Fig. 36, *h*). Here and

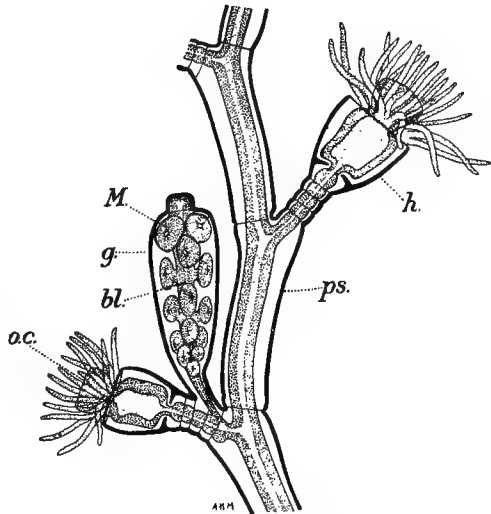

FIG. 36.

Obelia. Portion of hydroid colony. $\times 25$. *bl*, Blastostyle; *g*, gonotheca; *h*, hydrotheca; *M*, medusa bud; *o.c.*, oral cone; *ps*, perisarc.

there in the angle between a hydrotheca and the stem of the colony there is present a vase-shaped **gonotheca** (Fig. 36, *g*). This, like the ordinary hydrotheca, contains an individual of the colony but one very different from the ordinary hydroid polyp. This individual—the **blastostyle** (Fig. 36, *bl*)—is somewhat piston-shaped, its end being in the form of a flattened disc without trace of tentacles or mouth opening. Its special function is that of reproducing by budding, and numerous buds may commonly be seen projecting from its surface. In their young stage, as may be seen towards the lower end of the blastostyle, the buds are just like those of *Hydra* but the older buds (Fig. 36, *M*), visible

near the upper end of the blastostyle, are seen to be developing into something very different from a hydroid polyp. Eventually the fully

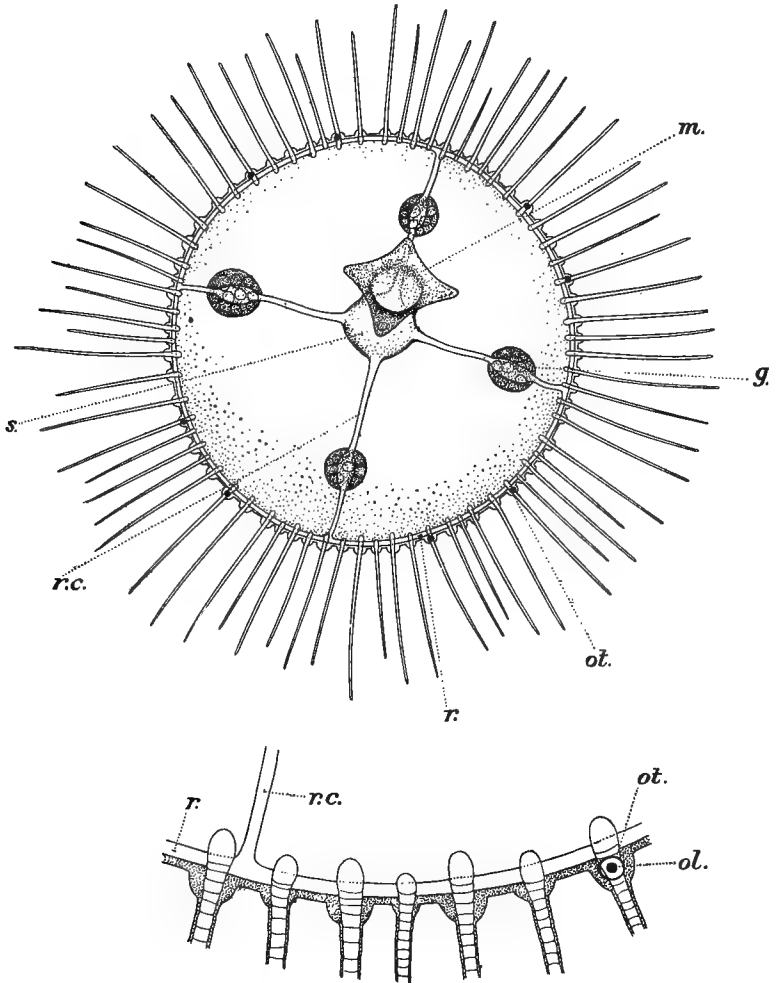

FIG. 37.

Obelia. Medusa seen from below. $\times 30$. The lower figure represents a small portion of the margin of the umbrella more highly magnified. *g*, Gonad; *m*, manubrium with mouth; *ol*, otolith; *ot*, otocyst; *r*, ring canal; *r.c.*, radial canal; *s*, stomach.

developed bud breaks off, makes its way to the exterior through the opening at the top of the gonothea, and is now seen to be not a hydroid

but a small jelly-fish or **medusa** (Figs. 37 and 41, D). This swims about, feeds and grows, and when fully developed has the following structure.

The larger part of the body is concavo-convex, somewhat umbrella-like, in form and is technically known as the **umbrella**. In the centre of the concave surface, in place of the umbrella handle, is a short thick projection—the **manubrium** (Figs. 37 and 41, D, *m*). From the edge of the umbrella extends a fringe of fine threadlike tentacles. Study of the minute structure of the medusa shows it to be composed of the same layers as the hydroid, only the mesogloea is greatly thickened forming in any ordinary jelly-fish the mass of clear jelly from which the creature gets its popular name.

The ectoderm covers the whole external surface and it shows a distinct advance in evolution from that of *Hydra*. More especially on the lower concave surface of the umbrella the myo-epithelial cells have their contractile tails much more strongly developed so as to form powerful muscles, arranged concentrically with the edge of the umbrella. By means of these the medusa makes the familiar pulsations, opening and shutting, by which it swims through the water. Further we find distinct rudiments of a nervous system. Here and there scattered through the ectoderm are **sensory cells** (Fig. 38, *s*), tall and slender in shape, bearing at their outer end a fine **sensory hair** of protoplasm which projects freely into the surrounding water and serves to receive impressions from the outer world. The sensory cells are prolonged at their inner end into a protoplasmic thread—a **nerve-fibre** (*a.f*) which joins with many others to form a **plexus** or network lying near the inner limit of the ectoderm all over the creature's body. Here and there such a fibre may be traced to a cell lying in the deep layers of the ectoderm (Fig. 38, *g.c*), or beneath it entirely—a **ganglion-cell**, probably to be interpreted as a sensory cell which has become withdrawn from the surface. Sometimes it is possible to trace another nerve fibre (Fig. 38, *e.f*) passing away from the ganglion cell and leading to a muscle cell (*m*). Here we have an excellent example of a nervous mechanism of the simplest possible type, consisting of a **nerve centre**—in this case a single ganglion cell—and in relation with it a sensory or **afferent** path along which come messages or impulses from

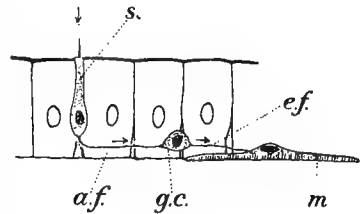

FIG. 38.

Illustrating the nervous mechanism of Medusae. *a.f*, Afferent (sensory) nerve fibre; *e.f*, efferent (motor) nerve fibre; *g.c*, ganglion cell; *m*, muscle cell; *s*, sensory cell.

a sensory or perceptive apparatus, and a motor or **efferent** path along which impulses are sent from the nerve-centre towards a muscle to make it contract.

At eight points on the margin of the umbrella there is present a special collection of sensory cells forming a sense-organ, in this case an **otocyst** or primitive ear, an organ not for hearing but for performing the far more ancient function of otocysts, that of perceiving change of position in relation to the vertical. The otocyst (Figs. 37, *ot*, and 39) is a rounded sac situated on the lower side of the rounded swollen base of a tentacle. The wall of the otocyst is very thin consisting of two layers of greatly flattened cells, a covering layer of ectoderm, and a lining layer. Of the lining cells some have not the flattened form characteristic of the majority. The most conspicuous of these is a large club-shaped

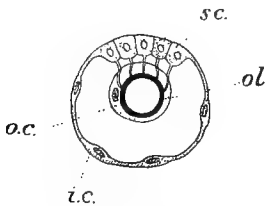

FIG. 39.

Otocyst of *Obelia*, highly magnified, seen from above. *i.c.* Undifferentiated cells lining cavity of otocyst; *o.c.* cell which secretes otolith in its interior; *ol*, otolith; *s.c.* sensory cells.

cell which projects into the cavity and the end of which is weighted by a large spherical mass of very dense calcium carbonate, the **otolith**, secreted within its cytoplasm. The otolith (Fig. 39, *ol*) in its containing cell (*o.c.*) rests lightly upon sensory hairs which project from a patch of 4-7 sensory cells (*s.c.*) into the cavity of the otocyst.

It is clear that the action of gravity upon the dense, relatively heavy, otolith will cause it to bear down upon the sensory hairs which support it. It is clear further that the strain upon the sensory hairs will be altered if the position of the medusa be changed, e.g. if it be tilted up on edge. It is apparently in this way that the otocyst conveys to the medusa the information that its position has become abnormal.

The coelenteric cavity is small in comparison with the bulk of the medusa, having been for the most part obliterated by the great development of mesogloea. Right in the centre of the medusa a portion of the cavity remains patent, forming what is usually termed the **stomach** since in it the main digestion of the food takes place (Figs. 37 and 41, *s*). This communicates with the exterior by a wide four-rayed mouth at the end of the manubrium. It also extends outwards towards the edge of the umbrella as four tubes, the **radial canals** (Figs. 37 and 41, *r.c.*). These are connected as are the ribs of an ordinary umbrella by a thin membrane—in this case representing coalesced portions of the endodermal roof and floor of the coelenteron. Around its extreme outer margin

the coelenteric cavity is again patent forming the **ring canal** into which the radial canals open at their outer ends (Fig. 37, *r*).

The medusa is the sexual phase in the life-history of *Obelia*. It possesses gonad (Figs. 37 and 41, *g*) in the form of testes or ovaries which form four conspicuous pear-shaped or rounded masses hanging down from the lower (concave) surface of the umbrella, immediately beneath the radial canals. Each is situated, as in the case of *Hydra*, in the thickness of the ectoderm.

Obelia affords an excellent example of alternation of generations—generations of sexual individuals (in this case Medusae) being intercalated amongst others which are not sexual (in this case the individuals of the colony).

TUBULARIA

It is interesting to compare with *Obelia* another common marine Hydrozoon—*Tubularia*.

Here again colonies are formed by a process of budding, consisting of hydroid individuals which however differ from those of *Obelia* in various details, some unimportant, some important. Amongst the former are the much greater size of the polyps, and the fact that a second set of smaller tentacles are present situated close to the tip of the oral cone and immediately surrounding the mouth (Fig. 40). The most important fact is that in *Tubularia* there is no hydrotheca surrounding and protecting the body of the polyp, the horny perisarc (*ps*) being restricted to its cylindrical stalk and stopping short of the swollen body of the polyp. Such a

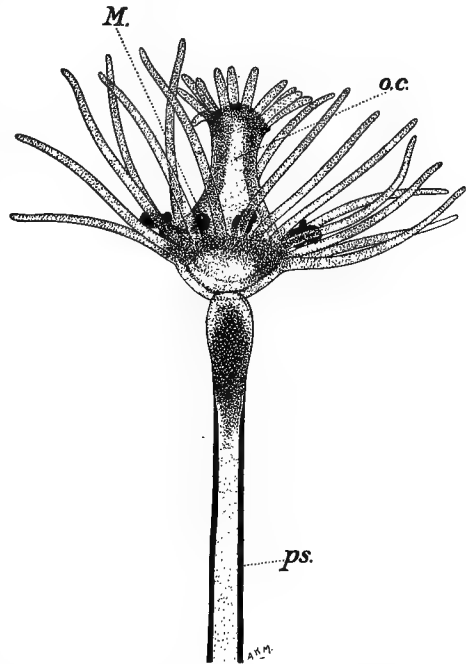

FIG. 40.

Tubularia, upper portion of a single polyp. $\times 17$.
M, young medusa bud; *o.c.*, oral cone; *ps*, perisarc.

type of hydroid without a hydrotheca is said to be **gymnoblasic**, in contradistinction to the **calyptoblasic** type in which a hydrotheca is present.

Tubularia belongs to a group in which the Medusae (Fig. 41, B) show important differences from those of *Obelia*. (1) They are deep bell-shaped instead of saucer-shaped; (2) the gonad (*g*) is situated not

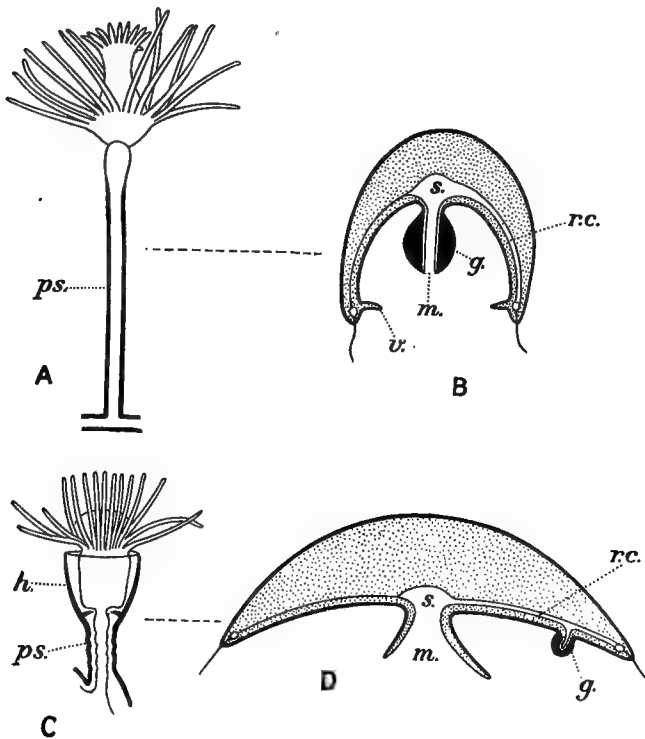

FIG. 41.

Diagram to illustrate the distinguishing features of A, Gymnoblasic polyp; B, Anthomedusa; C, Calyptoblasic polyp; D, Leptomedusa. *g*, Gonad; *h*, hydrotheca; *m*, mouth; *ps*, perisarc; *r.c.*, radial canal; *s*, stomach; *v*, velum. [In Figs. B and D the right half of the figure is in the plane of a radial canal: the left half is in a plane between two radial canals.]

on the under surface of the umbrella but on the outer surface of the manubrium; (3) the sense-organs when present are usually in the form not of otocysts but of simple eyes. Such a type of medusa is known as an **Anthomedusa** (Fig. 41, B) in contradistinction to the **Leptomedusa** (Fig. 41, D) as exemplified by *Obelia*. In the genus *Tubularia* the medusoid generation is apparently commencing to degenerate, as the

medusae—budded off in this case by the ordinary polyps round the base of the oral cone (Fig. 40, *M*)—never become completely free but remain attached to the parent, looking eventually like minute bunches of grapes surrounding and sometimes hiding the oral cone almost completely. But though they never become free their structure is still clearly anthomedusan—they develop gonad on the surface of the manubrium, and the young hydroid individuals arising from the zygotes go on with their development within the shelter afforded by the umbrella.

Tubularia and *Obelia* illustrate two main types of structure and life-history found within the group Hydromedusae which is consequently divided into two sub-groups named, accordingly as the Hydroid or the Medusoid structure is regarded as more important :

- (1) GYMNOLASTEA or ANTHOMEDUSAE
 exemplified by *Tubularia*
 and (2) CALYPTOLASTEA or LEPTOMEDUSAE
 exemplified by *Obelia*.

The group contains a great variety of different genera and species, including many of our commonest marine animals, and constituting a large proportion of what were known to the older naturalists as Zoophytes.

ACALEPHAE

The third subdivision of the Hydrozoa, the Acalephae, includes the ordinary large jelly-fish or medusae such as are commonly seen swimming in the sea or cast up on the shore. One of the commonest of them, *Aurelia*—easily distinguished by the bright purple colour of the gonad which is in the form of four conspicuous ring-shaped or horseshoe-shaped masses—may be taken as an example of the group.

The general shape is similar to that of a Leptomedusa but there are characteristic differences in detail. The size is much greater. The four angles of the mouth are drawn out into long frilled structures. The radial canals (Fig. 42, *r.c.*) are sixteen in number and those opposite the angles of the mouth ("per-radial") as well as those exactly midway between them (inter-radial) branch as they pass outwards, while the eight alternating with these (adradial) retain their simple unbranched character. The stomach bulges outwards in the form of four rounded pockets, inter-radial in position, and the ovaries or testes are in the form of four horseshoe-shaped thickenings of the endoderm of the floor of these pockets (Fig. 44, *I, g.*). Probably for the purpose of bringing the sea-water

with its supplies of oxygen into close proximity to the gonad the lower surface of the umbrella is tucked inwards to form a **subgenital pit** (Fig. 44, I, *s.p.*), which remains freely open to the sea-water by a wide circular opening while the roof, separating it from the stomach and giving rise to the gonad on its upper or gastral surface, is comparatively thin. The gonad takes on as already mentioned a bright purple colour and the

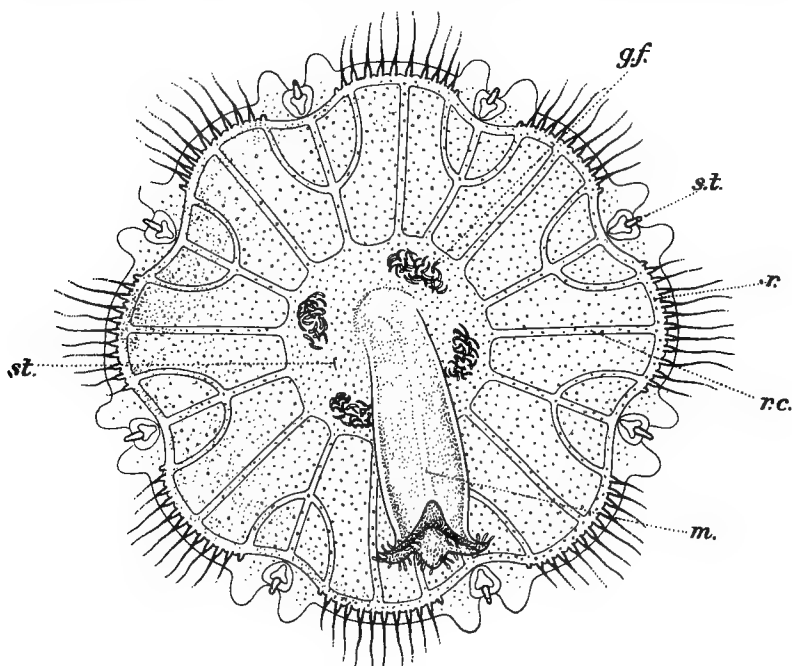

FIG. 42.

Aurelia, young specimen viewed from below. $\times 16$. *g.f.* Group of gastral filaments; *m.* manubrium with mouth opening at tip; *r.* ring canal; *r.c.* radial canal; *s.t.* sensory tentacle; *st.* stomach. [In the young specimen the angles of the manubrium have not yet grown out into long arms; the projecting pouches of the stomach and the gonads have not yet appeared; and the branching of the branched radial canals is not so complex as it is in the adult.]

gametes shed from it pass into the cavity of the stomach and thence to the exterior by the mouth opening. Within the curve of the gonad there project from the floor of the stomach a row of somewhat tentacle-like **gastral filaments** (Figs. 42 and 44, I, *g.f.*). The endoderm covering these is crowded with gland-cells which probably secrete digestive ferment: their presence constitutes a characteristic feature of the *Acalephae*.

The sense-organs (Fig. 42, *s.t.*) are highly characteristic: they are eight in number, situated round the margin of the umbrella per-radial and inter-radial in position, and are really tentacles which have become much shortened and modified to form sense-organs. Each is traversed by a tubular cavity continuous with the ring-canal and lined with endoderm. The somewhat swollen end of the tentacle is occupied by a solid mass of endoderm cells continuous with the lining of the tube already mentioned and the cells forming this secrete numerous masses of calcium carbonate so that the end of the tentacle is heavily weighted.

In *Aurelia* the sensory tentacle projects freely, although it is sheltered by a hood-like arrangement, but it is interesting to note that in some other medusae similar sense-tentacles come to be surrounded by a wall-like

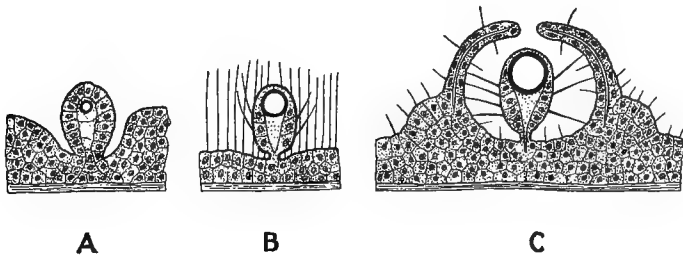

FIG. 43.

Illustrating the enclosure of a sensory tentacle within an otocyst in a Medusa—*Rhopalonema*. (After O. & R. Hertwig.) In the younger stages (A and B) the tentacle projects freely. In the later stage shown in C it is in process of being enclosed. In still later stages the opening of the otocyst becomes completely obliterated.

upgrowth which eventually arches over and causes them to be completely enclosed in an otocyst (Fig. 43).

As in the Hydromedusae so also in the Acalephae a polyp phase occurs in the life-history, but it is small and inconspicuous as compared with the medusoid phase. The eggs are fertilized within the stomach by microgametes which have come in from the exterior and the zygotes so formed pass out through the mouth opening and along the groove extending from it along the arm-like prolongations of the angles of the mouth. Here they become lodged in pocket-like outgrowths of the groove in which they proceed with their development. The zygote undergoes a process of segmentation which results in a spherical blastula. One wall of this becomes tucked within the other very much as one hemisphere of a child's indiarubber ball may be pushed within the other (Fig. 44, A). In this way is reached a very important stage of development known as

the **gastrula** (Fig. 44, B). The characteristic features of the gastrula are : (1) that its shape is cup-like, (2) that it has a simple internal cavity

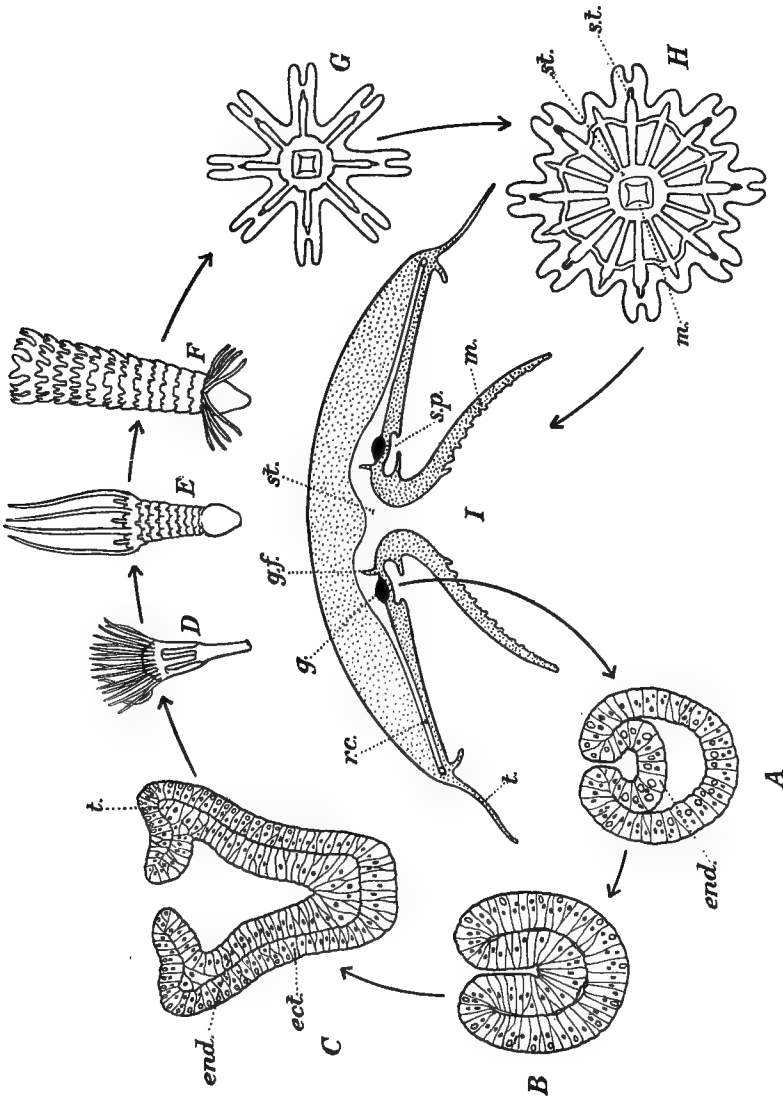

FIG. 44. *Aurelia*, life-history. A, B, C, longitudinal sections through gastrula stages; D, E, F, Strobila; G, H, Ephyra; I, vertical section through adult. [A, B, and C are more highly magnified than the other figures.] *end.*, Ectoderm; *eccl.*, endoderm; *g.*, gonad; *gf.*, genital filament; *m.*, manubrium; *r.c.*, radial canal; *s.p.*, subgenital pit; *st.*, stomach; *t.*, tentacle.

—the **archenteron**—which communicates with the exterior by a single opening—the primitive mouth or **protostoma**, and (3) that its wall consists

of two layers of cells, an outer ectoderm and an inner endoderm. It will be seen that the gastrula in its fundamental characteristics agrees with *Hydra*: the differences are rather differences in detail—the cup-like body being in *Hydra* deepened to form a tube, the mouth being narrowed into a minute pore, the body-wall being prolonged to form the tentacles, and the component cells being specialized for different functions. The fundamental similarity which underlies these superficial differences justifies the statement that the gastrula phase in the development of an animal is in fact simply a temporary hydroid phase.

In the case of *Aurelia* the gastrula undergoes a series of modifications which culminate in a condition very much like that of *Hydra* even in detail. The gastrula assumes a tubular form and the mouth becomes narrowed into a minute pore (Fig. 44, C). It makes its way out of the shelter in which it has developed so far and swims away through the water by means of powerful cilia which have developed from its ectoderm. The free-swimming larva presently attaches itself by its closed end to some solid body, very often the frond of the large Tangle or Oar-weed (*Laminaria*), and gradually takes the form of a little greyish-white creature which was supposed by the older naturalists to be simply a marine species of *Hydra* and given the name *Hydra tuba* (Fig. 44, D). Features which distinguish it from the true *Hydra* are the larger number of tentacles and the fact that the endoderm undergoes an increase in area by forming four folds which project into the coelenteron as four longitudinal ridges.

This hydroid stage in the development of *Aurelia* is known as the **scyphistoma** stage. The scyphistomas may sometimes be observed during the autumn in untold myriads, dotted about on the fronds of *Laminaria*, in our quiet sea-lochs.

The scyphistomas feed actively, grow, and multiply by budding during the autumn months but during the early winter a change begins to come over them. Ring-like constrictions encircle the body and gradually deepening divide it into a pile of saucer-shaped structures one over the other (**strobila** stage—Fig. 44, E and F). The margins of these saucer-shaped bodies grow out each into eight lobes, while the scyphistoma tentacles upon the uppermost one degenerate and disappear. Finally the saucer-shaped pieces break off one by one and swim away as little star-shaped medusae (**ephyra** stage—Fig. 44, G) each with eight lobes radiating outwards. Careful examination of the ephyra shows it to be, notwithstanding its star shape, a young *Aurelia* medusa, for in a little recess at the end of each of the eight arms there may be recognized the characteristic sensory tentacle just like that of the adult (Fig. 44, H, *s.t.*). The ephyrae grow rapidly, the spaces between the rays becoming gradually

obliterated by specially active outward growth so that the nearly circular outline of the adult is attained.

Besides *Aurelia* the group Acalephae includes a number of other common and conspicuous Medusae. *Cyanea* is the common stinging jelly-fish familiar to bathers. In this case the threadlike tentacles round the margin of the umbrella are very long—it may be several feet in length, and they are richly provided with large and powerful nematocysts the discharge of which into the skin produces the stinging sensation.

The more important of the features which mark off the Acalephae from the Hydromedusae are (1) the greater size and conspicuousness of the Medusa stage of the life-history; (2) the endodermal position of the gonad; (3) the presence of gastral filaments; and (4) the presence in the polyp stage of four longitudinal folds of the endoderm. This last-mentioned feature is of special interest from its foreshadowing a condition seen in a much higher degree of development in the Actinozoa.

The three types of Coelenterate so far dealt with—the Hydra-like forms (Hydrida) without any medusoid phase in their life history, the Hydro-medusae, and the Acalephae—are included in the first of the two main subdivisions of the phylum Coelenterata, the HYDROZOA. Apart from the frequent occurrence of the Medusa type of structure, the two special distinguishing features of the Hydrozoa are that in the polyp stage the mouth opening is situated at the outer end of the projecting oral cone and the coelenteron is a continuous cavity throughout, although it may be slightly encroached on by inwardly projecting folds of endoderm (scyphistoma).

The remaining Coelenterates are grouped together as the ACTINOZOA. Of these we shall take as our first example the genus *Alcyonium*.

ALCYONIUM

The orange or pale yellow or pale flesh-coloured colonies of this animal, of an irregularly lobed shape which has suggested the popular name "Dead Men's Fingers," are to be found attached to rocks and stones from about low-water mark downwards. A specimen removed from the water (Fig. 45, A) shows no obvious sign of life, but if placed in fresh sea-water there will gradually protrude from its surface numerous semi-transparent polyps showing it to be a colonial organism (Fig. 45, B). The protruding portion of the polyp (Fig. 46) is somewhat cylindrical

in shape and at its free end has a slit-like "mouth" surrounded by a circle of eight tentacles each of which is pinnate in form. The mouth opening leads into a flattened tube, the **stomodaeum** (Fig. 46, *st*), which hangs down into the coelenteron and opens into the latter at its truncated lower end. This stomodaeum corresponds with the oral cone of the Hydrozoa, but here, instead of projecting outwards, it has become as it were inverted into the interior of the polyp. It is therefore *lined* with ectoderm. Along one edge the cavity of the stomodaeum dilates to

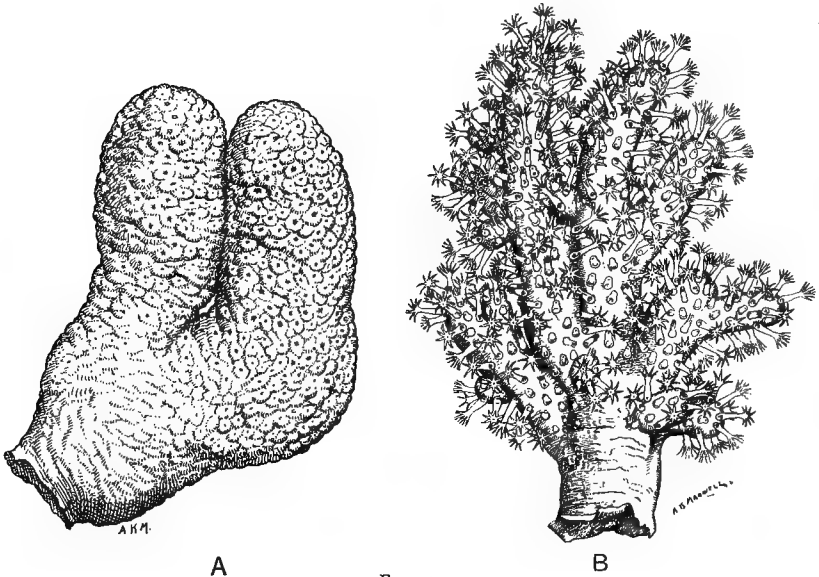

FIG. 45.

Alcyonium. $\times \frac{2}{3}$. A, Colony as found cast up on the shore (*A. digitatum*); B, colony with polyps extended (*A. palmatum*).

form the **ciliated** groove (Fig. 47, A, *c.g.*), the cells along the floor of which carry powerful flagella and serve to pump fresh sea-water into the coelenteron. The stomodaeum does not simply hang freely in the coelenteron but is slung up by eight delicate membranes, the **mesenteries**, which radiate out from the stomodaeum to the outer wall (Fig. 47, A, *M*). These mesenteries are covered, as are all surfaces abutting on the coelenteric cavity, by endoderm: each is formed of two layers of endoderm cells with an interposed layer of mesogloea. Along the surface which faces the ciliated groove (often called the "ventral" surface) each mesentery possesses a longitudinal thickening of its endoderm, caused

by a special development of longitudinally running muscles (Fig. 47, *m*): these are largest on the pair of mesenteries next the ciliated groove and are smaller and less conspicuous on those furthest removed from it.

The mesenteries are prolonged downwards beyond the truncated end of the stomodaeum and are then attached only by one—the outer—edge to the body wall, the opposite margin projecting freely into the

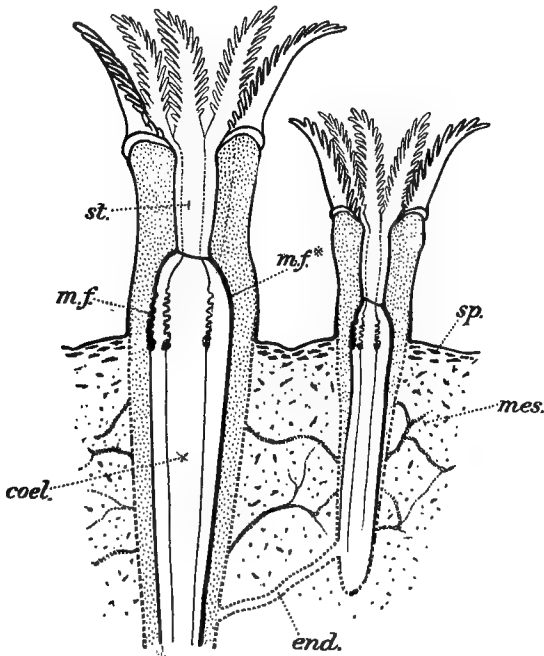

FIG. 46.

Alcyonium. Vertical section through part of colony. *coel*, Coelenteron; *end*, endodermal tube connecting coelentera of two neighbouring polyps; *m.f.*, mesenterial filament; *m.f.**, dorsal, uncoiled, mesenterial filament; *mes.*, mesogloea; *sp.*, spicule; *st.*, stomodaeum.

coelenteron (Fig. 47, B). The free edge is thickened to form a conspicuous thread—the **mesenterial filament** (*M.f.*).

The coelenteric cavity of the projecting portion of the polyp is prolonged downwards into the substance of the colony, the mesenteries being also prolonged downwards. In the case of the two mesenteries furthest from the ciliated groove (“dorsal” mesenteries) the mesenterial filament is straight, is continued right down into the basal part of the coelenteron, and is covered with cells bearing powerful cilia which beat

in such a way as to produce an upward current of water towards the stomodaeum. In the case of the six other mesenteries the mesenterial

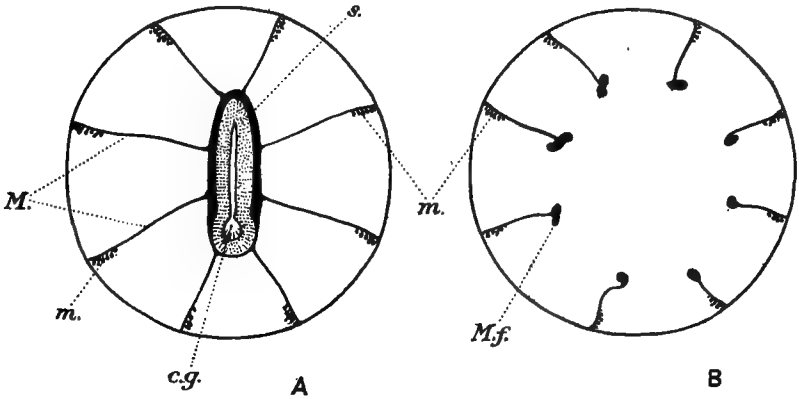

FIG. 47.

Alcyonium: transverse sections. A, through stomodaeum; B, slightly below stomodaeum. *c.g.*, Ciliated groove; *M.*, mesenteries; *m.*, muscle; *M.f.*, mesenterial filament; *s.*, stomodaeum.

filament is much folded, forming a little skein-like mass; it extends only for a short distance down the free edge of the mesentery and its epithelial covering is crowded with gland-cells, which secrete the digestive ferment. Below the level of the mesenterial filaments these six mesenteries show during the winter months little rounded swellings near their free edge. These swellings are the young ovaries or testes, which are consequently endodermal in position as they are in the *Acalephae*.

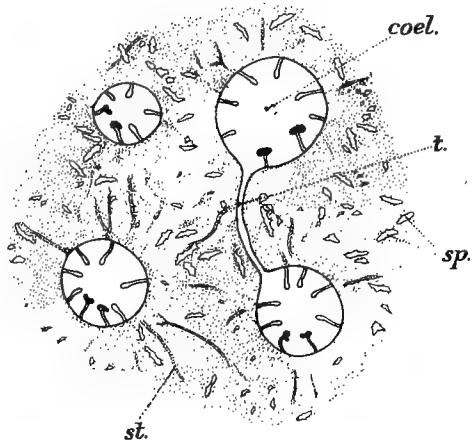

FIG. 48.

Portion of section through *Alcyonium* colony parallel to surface. *coel.*, Coelenteron with the eight mesenteries, the two dorsal ones showing mesenterial filaments (black); *sp.*, spicules; *st.*, strands and *t.*, tubes of endoderm connecting the walls of the various coelentera. The dotted groundwork of the figure represents the matrix of mesogloea.

The ectoderm covers the outer surface of the polyp and of the colony in general: the endoderm lines the coelenteric spaces. Between the two layers of cells are extensive regions filled

with stiff translucent mesogloea which gives solidity to the colony as a whole. This mesogloea forms a kind of packing between the various coelentera (Fig. 48) and it is further traversed by a coarse network composed of tubes (*t*) and strands (*st*) of endoderm which link up the various coelentera with one another. The mesogloea is further colonized by numerous amoeboid or mesenchyme cells which have wandered into it from the ectoderm. These immigrant ectoderm cells are functionally **scleroblasts**, i.e. their function is to produce skeleton. They settle down in the mesogloea and secrete **spicules** (Fig. 48, *sp*) of calcium carbonate of a characteristic thorny appearance though they vary much in their shape. These spicules are specially crowded together in the surface layer of the colony converting this into a harsh protective rind and giving the surface its characteristic colour.

ALCYONARIA

The group Alcyonaria includes a great variety of marine creatures agreeing with *Alcyonium* in their main features—the number (8) and shape (pinnate) of the tentacles, the eight mesenteries each with a muscular thickening on its ventral face, the presence in the mesogloea of a spicular skeleton formed by immigrant ectoderm cells, and as a rule the formation of a colony by a process of budding.

Before leaving the group it will be well to notice one or two interesting departures from the condition seen in *Alcyonium* as regards the skeleton.

The well-known “Red Coral” is formed by an Alcyonarian named *Corallium*, the colonies of which differ conspicuously from those of *Alcyonium* in their being slender and much branched, and in their bright red colour due to the colour of the spicules. In *Alcyonium* the spicules are specially crowded together towards the surface of the colony: in *Corallium* a similar crowding together takes place along its axis, where however the spicules become actually cemented together to form a solid rod-like mass which is “Red Coral.”

Another Alcyonarian the colonies of which have slender branches supported by an axial skeletal rod is *Gorgonia*, but in this case an interesting difference exists in the mode of formation of the skeletal rod. The young commencing colony secretes a plate of horny material between its base and the substratum to which it is attached. As the colony grows, more material is added by the secretory activity of the basal ectoderm, so that the plate becomes converted into a little hillock, still more is added till it forms a cylindrical pillar, and this being added to continuously becomes gradually converted into a long rod over

which the substance of the colony is stretched like a glove over a finger. Spicules—often brilliantly coloured—are present as usual but, as will have been gathered, they take, in *Gorgonia*, no part in the formation of the axial rod.

ZOANTHARIA

This group includes the ordinary sea-anemones, so commonly seen in rock pools or attached to the piles of piers. While agreeing in their

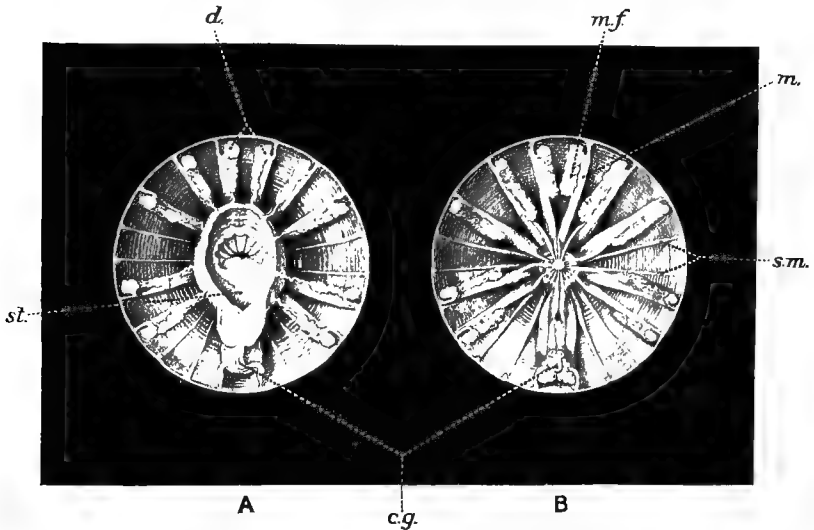

FIG. 49.

A Sea-anemone (*Peachia*) bisected transversely. A, Upper; B, Lower half. *c.g.*, Ciliated groove; *d.*, directive mesenteries; *m*, muscle of mesentery; *m.f.*, mesenterial filament; *s.m.*, muscles of secondary mesenteries; *st.*, stomodaeum.

general structure with Alcyonarian polyps they show characteristic differences in detail.

The individual polyps are normally of much larger size and as a rule they do not form colonies. They may reproduce asexually by budding or by a process of fission from above downwards but the individuals so arising separate from one another and lead an independent existence.

The tentacles instead of being pinnate are simply conical: instead of being eight in number they are numerous, and commonly arranged in several rows. The stomodaeum is usually provided with two ciliated grooves, on opposite sides, although in some of the more primitive anemones there is only a single ventral groove as in the Alcyonarians (Figs. 49 and

50, *A, c.g.*) The stomodaeum is slung up to the body-wall by mesenteries showing the same characteristics—muscles (*m*), mesenterial filaments (*m.f.*), gonad—as in the Alcyonarians but these mesenteries show characteristic differences in their arrangement. They are more numerous and are distinguishable into different sets—**primary mesenteries**, which at their inner edge are attached to the wall of the stomodaeum, and others (secondary, tertiary, etc.—Figs. 49 and 50, *s.m.*) much smaller, which extend inwards only a short distance and do not reach the stomodaeum. Of primary mesenteries the number is from twelve upwards. They are arranged in couples and in each couple the muscular thickenings

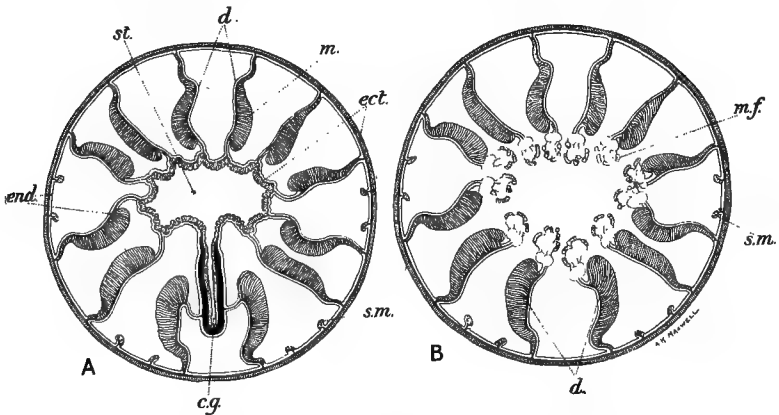

FIG. 50.

Transverse sections through a simple Sea-anemone (*Peachia*). A, Through stomodaeum; B, below stomodaeum. *c.g.*, Ciliated groove; *d.*, directive mesenteries; *ect.*, ectoderm; *end.*, endoderm; *m.*, muscle; *m.f.*, mesenterial filament; *s.m.*, secondary mesentery; *st.*, stomodaeum. The mesogloea is indicated by a black line.

face towards one another, except in the case of the **directive** mesenteries, the couple which support the ventral ciliated groove and the couple directly opposite, which support the dorsal ciliated groove if there is one. In the case of these directives the muscles are borne not on the inner but on the outer surface, i.e. they face away from one another (Fig. 50, *d.*).

The ordinary sea-anemone attaches itself temporarily, the attachment being aided by cement secreted by the gland-cells of its base. While as a rule this cement is imperceptible it may on the other hand form a distinct horny layer, as happens in *Adamsia*, an anemone which commonly lives symbiotically on shells inhabited by Hermit Crabs. Finally in a large subdivision of the Zoantharia the secreted mass, composed of

calcium carbonate and bulky in amount, forms a characteristic external skeleton—**coral**.

These zoantharian corals show a wonderful variety of form and size and complexity. In the simplest type there is first laid down a thin flat plate of calcium carbonate between the base of the polyp and the solid substance, rock or shell, on which it rests (Fig. 51, *th*). Along radiating lines, alternating with the mesenteries, the secretion becomes more active so that ridges are formed which increase in height and become thin vertical plates—the **septa** (cf. Figs. 52 and 53). A circular ridge is formed connecting the septa near their outer ends, and this also increasing in height forms the rim of a cup or **theca** in which the polyp rests (cf. Fig. 52, A). Very often a mound of calcium carbonate is deposited in the centre from which the septa radiate, and this increasing in height becomes the **columella**. It is important to bear clearly in mind that all this calcium carbonate is laid down by the outer surface of the ectoderm of the base of the polyp, so that it is strictly speaking entirely outside the living substance; it is an external skeleton or **exoskeleton**, although its various parts are closely ensheathed by the polyp floor which is pushed upwards as they increase in height.

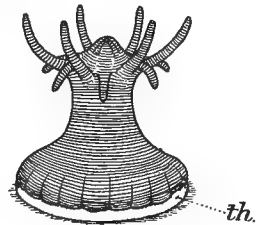

FIG. 51.

A young Coral-polyp (*Astroides*). (After Lacaze-Duthiers.) *th*, Calcareous plate forming the commencement of the theca.

The simplest type of coral is a simple cup or theca with radiating septa (Fig. 52, A) but there exist many complications of this simple type, due for the most part to peculiarities in processes of asexual reproduction. Coral polyps, unlike ordinary anemones, very usually form communities or colonies by processes of budding or fission. By budding a tree-like colony may be built up of numerous conical thecae, each containing an isolated polyp, as in the case of *Lophohelia* (Fig. 52, B), masses of which are sometimes drawn up on fishermen's long lines off our western and northern coasts. In other cases the polyps do not become completely separated but remain in continuity. In this case the layer of living tissue between the polyps (**coenenchyme**) goes on secreting calcium carbonate on its basal surface and consequently the individual thecae instead of being quite separate are connected together by an intervening solid mass (Fig. 52, C). Again in other cases a process of imperfect fission takes place. The polyp becomes much drawn out so that it is band-shaped instead of circular as seen from above, but there is no attempt at division into separate

polyps except that the mouth opening becomes divided up into a row of separate openings. In such a case the individual thecae instead of being circular are elongated (Fig. 52, D and E) and in extreme cases they become very greatly drawn out and pursuing a tortuous course give the mass of coral an appearance resembling that of the human brain ("Brain Corals"—Fig. 52, F).

In the Mushroom coral (*Fungia*—Fig. 53) a reproductive process recalling that seen in the strobilization of the scyphistoma takes place, the rim of the cup-shaped theca spreading out trumpet-fashion (Fig. 53, B)

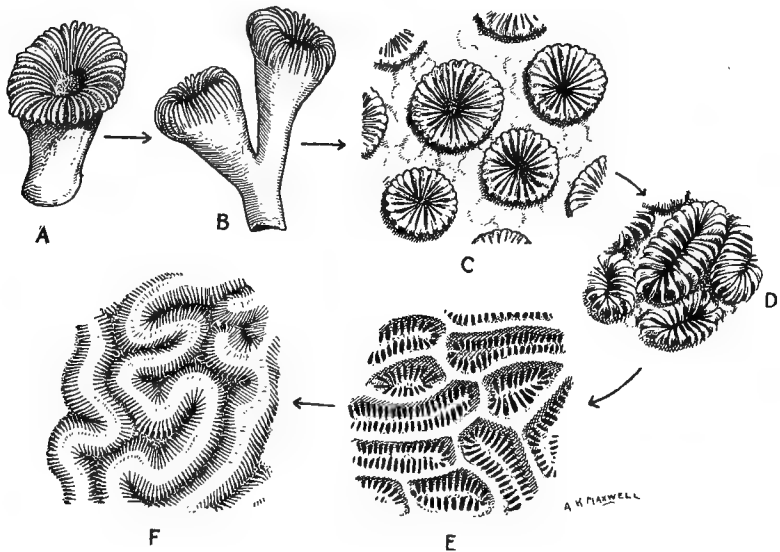

FIG. 52.

Zoantharian Corals. A, *Caryophyllia*; B, *Lophohelia*; C, *Solenastrea*; D, *Dichocaenia*; E, *Favia*; F, *Macandra*.

and eventually forming a flat disc which with the upper part of the polyp separates off and becomes independent, the process being repeated over and over again. The adult *Fungia*, cut off in this fashion, lies loose on the sea bottom, the theca being a flat disc with the septa radiating outwards on its upper surface (Fig. 53, C).

Many corals, including some of the commonest branching corals or Madrepores, are what is termed **perforate**—the wall of the theca being perforated by numerous openings which give it a spongy character. In such a case the addition of calcium carbonate to the rim of the theca is interrupted by tubular connexions between the main wall of the polyp

lying inside the theca and its flap-like extension which overhangs the lip and reaches for some distance down its outer surface. It is the interruptions in which lie these tubular connexions that show as foramina in the dry skeleton.

The ACTINOZOA, exemplified by the Alcyonaria and the Zoantharia, are clearly marked off from the Hydrozoa by a number of features which they possess in common. Their general form of body is of the polyp type: there is no medusoid phase in their life-history. The individual polyp is larger in size and more complex in structure than is that of the Hydrozoan. The part of the body corresponding to the oral cone of the Hydrozoan is turned inwards so as to hang down in the coelenteric cavity as the stomodaeum. The stomodaeal wall is sus-

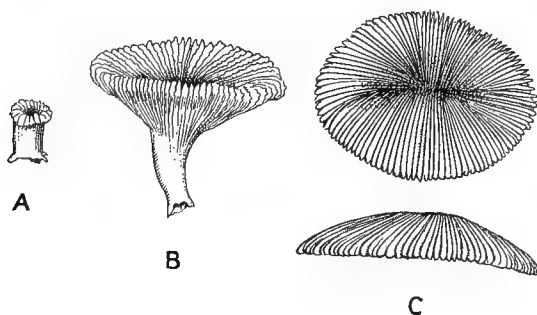

FIG. 53.

Mushroom Coral—*Fungia*. A and B, young fixed stages; C, adult condition. (A and B after Bourne.)

pended from the body-wall by the mesenteries—thin vertical partitions of mesogloea, the deep recesses between which are lined with endoderm. The endoderm on the face of the mesentery develops prominent longitudinal bands of muscle: it also develops the gonad. Finally, when a skeleton is present this is normally not in the form of thickened cuticle (perisarc) but in the form either of isolated spicules secreted in the mesogloea by immigrant cells from the ectoderm or of a mass of secretion formed underneath the ectoderm of the base.

The phylum COELENTERATA, the more important subdivisions of which have been dealt with in this chapter, includes what are on the whole the most nearly primitive members of the Metazoa. They are above all characterized (1) by the possession of a general internal cavity, the coelenteron, which has not yet become subdivided into a separate

enteron or alimentary canal and coelome or body-cavity, and (2) by the fact that the coelenteron communicates with the exterior by a single opening—the primitive mouth (**protostoma**).

The body-wall of the coelenterate consists of the two primary layers of cells, ectoderm and endoderm, separated by the jelly-like or membranous mesogloea. This latter is primarily a secretion formed by the activity of the two layers of cells bounding it but where it becomes bulky, as in the umbrella of the Medusa or the ground-substance of the colony of the Alcyonarian or the body-wall of the Anemone, it usually becomes colonized by cells of the primary cell-layers (most usually of the ectoderm) which have taken on an amoeboid character and wandered into it. These cells, which collectively constitute the **mesenchyme**, are of importance in connexion with the subsequent evolution of the Metazoa, for in many of the more highly evolved groups of animals the mesenchyme forms a large proportion of the entire bulk of the body and becomes specialized to form important tissues.

The two primary cell-layers are especially interesting in the coelenterate from the fact that they display to us incipient stages in the evolution of the muscular and nervous systems.

The myo-epithelial cell like that of *Hydra* is apparently the starting-point for the evolution of the muscle fibre as it occurs in the more complex animals. In such a comparatively actively moving coelenterate as a medusa the myo-epithelial cells on the under surface of the umbrella frequently have their cell-body reduced to the nucleus, with a small quantity of cytoplasm round it, lying beside the greatly enlarged contractile cross-piece. The myo-epithelial cell has in such a case actually become a **muscle fibre**.

The coelenterate nervous system consists of the scattered sensory cells, the ganglion-cells which have sunk inwards and lost their sensory hair, and the plexus or network by which sensory and ganglion-cells are linked together. As has already been indicated the Medusae show an advance in the evolution of their nervous system in the aggregation of sensory cells into groups so as to form definite sense-organs. Another feature of the Medusae is that they show a tendency for ganglion-cells also to be concentrated together in the neighbourhood of the margin of the umbrella to form **nerve centres**. In the Acalephae such a nerve centre is developed in the neighbourhood of the attached base of each sensory tentacle. From these centres emanate the stimuli that bring about the contraction of the muscle fibres and hence the rhythmic pulsations of the umbrella. If the tentacles with a small adjacent portion of the umbrella are carefully excised from the living *Aurelia* its pulsations

stop. If the umbrella is cut into eight sectors each with an uninjured nerve centre the eight sectors go on pulsating but they soon "lose step" with one another owing to the loss of continuity of the nerve plexus which linked them together into a single co-ordinated whole. In the Hydromedusae the nerve centre forms a continuous ring. In the polyp type of coelenterate with its less complex structure we do not find either definite sense organs or definite nerve centres, although in the Anemones an approach to the development of nerve centres is expressed by the tendency for ganglion-cells to be especially numerous in the region of the mouth and tentacles.

BOOKS FOR FURTHER STUDY

I. GENERAL TEXT-BOOKS

- Sedgwick.** Student's Text-Book of Zoology, Vol. I.
Hickson. The Cambridge Natural History, Vol. I.
Delage and Hérouard. Zoologie concrète, Tome II.

II. SYSTEMATIC WORKS FOR THE IDENTIFICATION OF SPECIMENS

- Hincks.** British Hydrozoa.
Mayer. Medusae of the World.
Gosse. Actinologia britannica.

CHAPTER III

PORIFERA

THE phylum PORIFERA (Sponges) is constituted by a group of organisms comparable in the degree of complexity of their structure with the Coelenterata but which are pretty clearly not Coelenterates. They appear to have arisen as a side branch during the evolution of the animal kingdom and to have sprouted out from the Protozoan stem quite independently of the Coelenterata. The essential characters of the group are most easily demonstrated by the study of young specimens of the comparatively simple **Ascon** type of sponge exemplified by the genus *Leucosolenia*, specimens of which may be found attached to overhanging rocks or stones or seaweeds near low-water mark on almost any coast.

LEUCOSOLENIA

The *Leucosolenia* has essentially the character of a tube one or two millimetres in diameter and whitish in colour. The tube is at first simple, as shown in the illustration (Fig. 54), but it becomes complicated by the development of lateral or basal outgrowths which may lead in the first case to the formation of complex tree-like masses, and in the second to the formation of colonies of "individuals" connected by a stolon which creeps over the surface of the substratum.

At its attached end the tube is closed while at its free end it opens by a wide opening—the **osculum** (Fig. 54, *os*).

The microscopic study of thin sections (Fig. 55) shows the wall of the sponge to be composed of two layers—an inner **gastral** and an outer **dermal** (Fig. 55, D). Of these the inner is the simpler for it is composed of a single layer of cells, all alike. These, the **choanocytes** or "collar-cells," are highly characteristic. Each is somewhat flask-shaped, contains a rounded nucleus rather nearer its free end, and is prolonged into a single powerful flagellum which projects inwards towards

the centre of the cavity of the sponge. These flagella beat actively and keep up an outwardly flowing current of water through the osculum. The most peculiar feature of the choanocyte and that which gives it its name is the presence of a thin soft membrane of protoplasm—the **collar**—which projects from the margin of the free end of the cell, forming a kind of tube or funnel, of which the axis is occupied by the flagellum. The protoplasm of the collar shows active streaming movements by which food-particles coming against and adhering to the collar are carried down into the cell-body. The collar can be retracted completely into the cell-body and as a consequence may be invisible in sections not prepared very carefully. The choanocytes line the whole cavity of the sponge except a region in the neighbourhood of the osculum which is floored in by the **sieve-membrane**—a thin perforated membrane stretching straight across the cavity of the sponge some little distance internal to the osculum (Fig. 54, *s.m.*).

The dermal layer consists of a matrix of clear jelly, resembling the mesogloea of the Coelenterates, with which are associated several types of cells. Covering the whole external surface and extending inwards at the osculum as far as the sieve-membrane is the **dermal epithelium** (Fig. 55, *d.e.*)—a layer of closely fitting polygonal cells

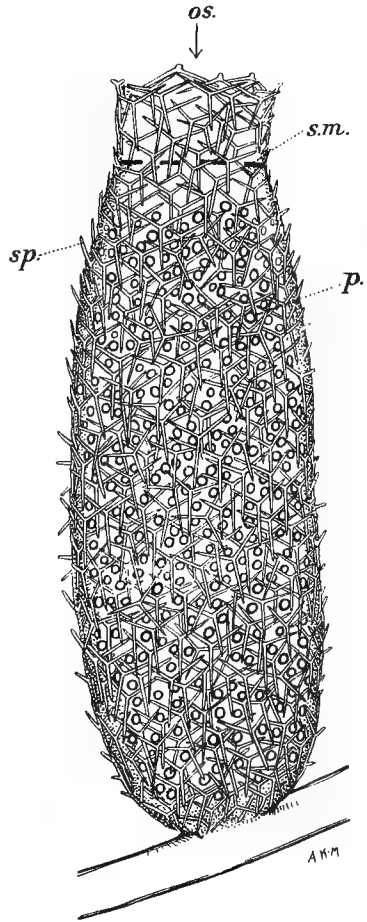

FIG. 54.

A young Ascon sponge. $\times 60$. *os.*, Osculum; *p.*, pore; *s.m.*, sieve-membrane; *sp.*, spicule.

so flattened out as to appear in section merely as a fine line with a dot here and there in its course representing a nucleus. In some of the allied sponges, though not in the genus *Leucosolenia*, these cells are highly contractile and

when the sponge shrinks up under unfavourable conditions the shrinkage is brought about by the contraction of the dermal epithelial cells. Dotted about at intervals in the dermal epithelium are modified cells known as **porocytes** (Fig. 55, *pc*). Each of these, instead of being thin and plate-like, extends inwards throughout the thickness of the dermal layer and, emerging between the choanocytes, comes into direct relation with the water in the cavity. When the sponge is fully expanded

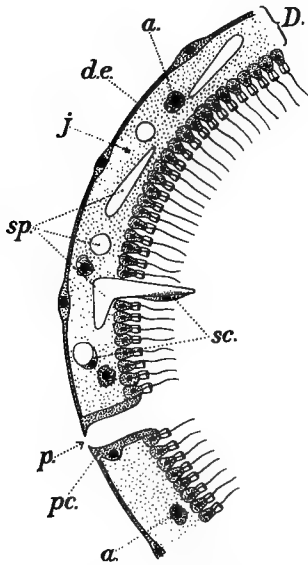

FIG. 55.

Diagram illustrating the structure of an Ascon as seen in a transverse section. *a*, Amoebocyte; *D*, dermal layer; *d.e.*, dermal epithelium; *j*, jelly; *p*, pore; *pc*, porocyte; *sc*, scleroblasts; *sp*, spicules.

the porocyte concentrates its protoplasm peripherally so that it forms a tubular sheath round an axial cavity which opens on the one hand on the external surface of the sponge and on the other into the gastral cavity. These temporary intracellular openings through the body-wall of the sponge are the **pores** (Fig. 55, *p*) and it is through them that there takes place the indraught of water necessary to replace that which passes out through the osculum.

Other cells of the dermal epithelium become modified as scleroblasts. These take on an amoeboid character, wander into the jelly, and there settle down to form the spicules which compose the skeleton of the sponge. These spicules are needles of calcium carbonate with an axial core and thin external sheath of organic material. The first formed spicules are simple needles (**monaxon** spicules—

Fig. 58, A, two lower figs.) but later

on there are formed numerous three-rayed (**triradiate**) spicules each of which represents a group of monaxon spicules radiating from a point (Fig. 58, A, upper fig.).

The mode of formation of these compound triradiate spicules is characteristic. Three scleroblasts approach one another and arrange themselves in trefoil fashion. The nucleus of each cell divides, and between the two nuclei a fine needle-like spicule makes its appearance. The three spicules become continuous centrally so as to form the three rays of the compound triradiate spicule. Each ray lies between two

more or less distinct though closely apposed cells, formed by the cytoplasm of the original scleroblast clumping together round the two nuclei. As the two spicule-forming cells keep on depositing more and more calcium carbonate on the spicule they wander apart, one passing towards the tip of the ray, the other remaining at its base. Eventually the apical cell disappears and after a time the basal cell wanders out and takes its place at the tip of the ray (Fig. 55, *sc*).

One of the rays of the triradiate spicule commonly differs in length from the other two, the whole spicule having a Y-shape. The spicule has a definite orientation, the unpaired ray, forming the stem of the Y, being arranged longitudinally and pointing away from the osculum (Fig. 54). In accordance with the cylindrical form of the wall of the sponge in which they are embedded the two equal rays are not exactly in the same plane and they may be slightly curved.

Of the cells which leave the dermal epithelium and wander into the jelly a third set are characterized by their retaining a to-all-appearance undifferentiated amoeboid character. These amoebocytes (Fig. 55, *a*), which are found scattered irregularly through the jelly, play an important part in the life of the sponge. They serve for the transport of food and excretory material, and it is some of them that function as the gonad. In the latter case the cell rounds itself off and either divides over and over again to form a mass of microgametes, or simply increases in size and stores up reserve food material or yolk, becoming a single egg or macrogamete.

The above description has dealt with the genus *Leucosolenia* but young Ascons collected for practical work will often be found to belong to another genus—*Clathrina*. While agreeing in its main features with *Leucosolenia*, *Clathrina* presents certain differences in detail which serve for its identification. (1) The individual tubes and their branches tend to undergo fusion together so as to form a kind of network; (2) the nuclei of the choanocytes are close to their basal or attached end; and (3) all three angles between the rays of the three-rayed spicules are equal.

GRANTIA

The Ascon is one of the simplest types of Sponge. A good idea of the way in which sponge structure becomes more complicated is obtained by the study of another very common type of sponge—the **Sycon** type—exemplified by the genus *Grantia* (Fig. 56). While built up of precisely the same elements as the Ascon, the Sycon differs in its usually larger size and more complicated arrangement of these elements. Simple

Ascons like *Leucosolenia* frequently undergo an imperfect kind of budding, the body-wall growing out into tubular pockets which radiate out at right angles to the long axis of the sponge. Now in a typical Sycon the whole surface is beset by such outgrowths in close contiguity with one another (Fig. 57, B). At their free ends the outgrowths are fused more or less together so as to present a continuous surface broken by small openings which lead into the spaces between the original outgrowths, these spaces being now known as the **inhalent canals** (Fig. 57, C, *i.c.*). These canals, being as it were parts of the outer world enclosed between the outgrowths, are lined with ordinary dermal epithelium similar to that covering the rest of the outer surface. The pores in the Sycon are restricted to the walls of the inhalent canals and are consequently not visible when the sponge is viewed from the outside (Fig. 57, C). The interior of the Sycon is divided into a **central cavity** (*c.c.*) and **radiating chambers** (*r.c.*), the latter representing the cavities of the outgrowths. Finally the choanocytes are found only in the radiating chambers, the central cavity being lined with a simple thin epithelium like that covering the external surface.

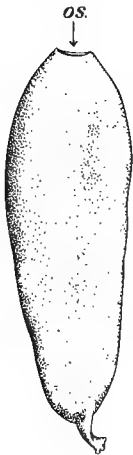

FIG. 56.

Grantia. × 6.
os, Osculum.

Apart from the differences that have been mentioned the Sycon type of sponge agrees with the Ascon: here again the body-wall is composed of the same elements—gastral layer with its choanocytes, and dermal layer with its jelly, its dermal epithelium, its porocytes, amoebocytes and scleroblasts.

The PORIFERA are, with the exception of a few genera, marine in habit. They vary greatly in size and form—the differences in general appearance being due in great part to imperfect processes of budding and fission: e.g. the sponge may reach a relatively large bulk and numerous oscula scattered over its surface betoken so many incompletely separated individuals. Internally the differences have to do mainly with differences in the spaces, which are referred to collectively as the **canal-system**. In the Ascons there is just the single gastral cavity (Fig. 57, A); in the Sycons there is the central cavity and the radiating chambers to which the choanocytes are restricted (Fig. 57, B and C); in still other sponges the chambers containing the choanocytes become small and rounded in form while their communications with inhalent canals and with central cavity become drawn out into more or less complicated tubular channels.

Throughout the group we find the two main layers of cells, gastral and dermal, and everywhere we find the various types of cells which occur in the Ascon. There are characteristic differences in the shape of the spicules and their chemical composition as will appear later.

A number of different sponges, mostly inhabitants of fresh water, although some of them are marine, possess an interesting adaptive arrangement by which they are enabled to tide over periods of unfavourable conditions, such as winter in a cold climate, or the dry season in a warm one. This consists in the development of what are known as **gemmules** and the process is well seen in our common fresh-water sponges. As the period of unfavourable conditions comes on, amoebocytes which have stored up in their cytoplasm large quantities of yolky reserve

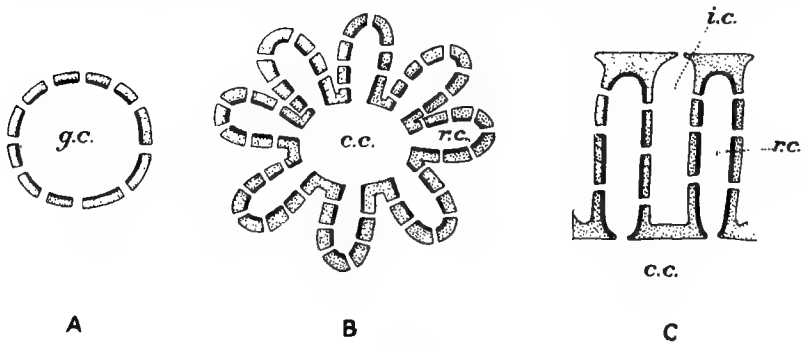

FIG. 57.

Diagrammatic transverse sections of the Ascon (A) and Sycon (B, C) types of sponge. The layer of choanocytes is represented by the heavy black line, the dermal epithelium by a thin line, and the jelly by fine dots. *c.c.*, Central cavity; *g.c.*, gastral cavity; *i.c.*, inhalent canal; *r.c.*, radiating chamber.

food-material congregate together in more or less spherical clumps, usually rather less than half a millimetre in diameter and conspicuous to the naked eye from the yellowish colour due to the yolk. Round these spherical masses which are the gemmules there collect other cells of a glandular nature, and apparently by the activity of these the gemmule becomes surrounded by a tough capsule. External to this spicules are collected together to form a further protective envelope. As conditions become more and more unfavourable the ordinary cells of the sponge die away and eventually there is left simply the sponge skeleton with the gemmules scattered through its meshes. This condition persists until conditions again become favourable when the gemmules hatch out, their cells become distributed through the substance of the sponge, they multiply actively and, becoming differentiated in various directions,

provide the sponge with a complete new cell-outfit such as it had during the preceding season.

The Porifera are classified as follows into three main subdivisions :

I. CALCAREA

This subdivision includes the Ascon and Sycon types which have already been described. It is characterized above all, as indicated by its name, by the fact that the spicules are composed of calcium carbonate. As regards shape the triradiate spicules are particularly characteristic but besides these there are commonly present straight or curved monaxon spicules, and four-rayed spicules derived from the triradiate by the addition of a small fourth ray which projects inwards into the gastral

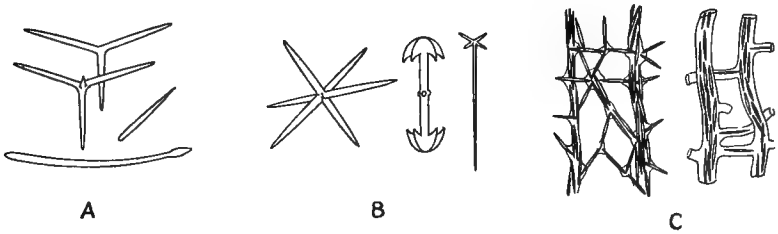

FIG. 58.

Skeleton of Sponges. A, Calcareous spicules (*Leucosolenia*); B, siliceous spicules (*Hyalonema*); C, siliceous spicules with spongine (*Pachychalina* and *Chalina*).

cavity (Fig. 58, A; Fig. 55). The general plan of structure is primarily that of the Ascon but complication may take place to a less or greater extent along the lines indicated on p. 122.

II. HEXACTINELLIDA

The Hexactinellids are for the most part deep-sea sponges: the general plan of their structure is somewhat Sycon-like: their most striking feature and that which gives them their name is the nature of their spicules. These latter are composed of clear glassy silica, in the form of three axes intersecting one another at right angles so as to give when all three axes are equally developed a spicule with six equal rays (Fig. 58, B). Very commonly the six rays are not developed equally—e.g. a single ray may be reduced or absent as in the right-hand spicule of Fig. 58, B, or the four rays in one plane may be reduced so as to produce a spicule which has the deceptive appearance of being monaxon. Finally particular

rays may grow out at their ends or elsewhere into spikes, knobs or other projections as e.g. the middle spicule of Fig. 58, B.

Well-known members of the group Hexactinellida are illustrated by Figs. 59 and 60.

Fig. 59 represents the "Glass Rope Sponge," characterized especially by the tuft of gigantic spicules, looking like a piece of rope of spun glass, by which the sponge is rooted in the mud (Fig. 59, *r.s.*). Each of these rooting spicules possesses at its free end an anchor-like arrangement of recurved hooks which sometimes represent four reduced rays while at other times they appear to be secondary outgrowths. An interesting feature commonly seen in specimens of *Hyalonema* is the presence of small symbiotic anemones, attached to the portion of the root tuft which was not buried in the mud (Fig. 59, *an.*).

Fig. 60 illustrates the "Venus's Flower Basket" sponge—*Euplectella*—often brought as a curiosity from the East. Here the body of the sponge forms a cylindrical tube, closed at the top by a sieve-plate. The wall of the sponge is supported by a beautiful trellis-work formed of fused spicules, the strands of the trellis-work—longitudinal, circular, right-handed, and left-handed spirals—being so arranged as to meet the stresses to which the wall of the sponge is subject. When the sponge develops in situations where there is a prevalent current pressure in one direction the cylinder takes on a correlated curvature as in the specimen figured, the concavity of the curve facing the current. Further strengthening of the sponge may be brought about by the development of spiral flanges projecting from the surface as in the specimen figured (Fig. 60).

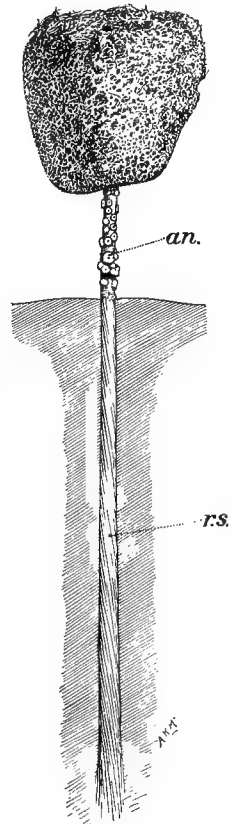

FIG. 59.

Skeleton of *Hyalonema*.
an. Small anemones (*Palythoa*) growing on portion of root above the surface of the mud ;
r.s. root spicules.

III. DEMOSPONGIAE

The Demospongiae comprise a great variety of sponges including most of the common and more conspicuous genera. The canal system

is usually complicated, small rounded chambers containing choanocytes communicating with two sets of tubular channels the one inhalent the other exhalent.

The spicules are composed of silica and are either tetraxon—with four rays diverging from a point at equal angles—or monaxon. The



FIG. 60.

Skeleton of *Euplectella*.

latter are frequently united into a continuous framework—not however by actual fusion between the siliceous substance of the spicules as is the case with the Hexactinellids—but by the interposition of a peculiar cement substance allied to silk in its chemical composition and known as **spongine**. In various members of the group an interesting modification of the skeleton has come about by the increase in amount of the cement substance and a corresponding reduction of the siliceous spicules

(Fig. 58, C). The final stage in this process is exemplified by the ordinary Toilet sponges¹ in which the spicules have completely vanished, leaving behind them the spongine framework. The Toilet sponge as purchased is simply this skeletal framework from which the protoplasmic tissues have been removed by putrefaction or maceration.

Amongst the Demospongiae are included the few genera, such as *Spongilla* and *Ephydatia*, which have forsaken the sea and live in fresh water. It is more especially these which have developed the power of forming gemmules.

Zoologists are very generally inclined to regard the Porifera as a group which has arisen in the course of evolution from the Protozoa independently of the Coelenterata and other Metazoa.

They take this attitude for two reasons amongst others. (1) The early stages in the development of the few types of sponge in which they have been investigated are peculiar and do not provide any evidence to show that the osculum of a simple sponge corresponds to the primitive mouth of the coelenterate. (2) Perhaps the most striking characteristic of the Porifera is

afforded by the choanocytes—a type of cell which, if it occurs at all, is of the greatest rarity in other Metazoa. Now there is a special section of the Protozoa, known as the Choanoflagellata, in which the cell individual is identical with a free-living choanocyte. Further a special genus of Choanoflagellata is known (*Proterospongia*—Fig. 61) in which a number of cell individuals remain associated together as a community. Some of these remain typical choanocytes while others, embedded in a jelly-like secretion, become amoebocytes. In *Proterospongia* we see actually existing a creature which may reasonably be interpreted as representing a first

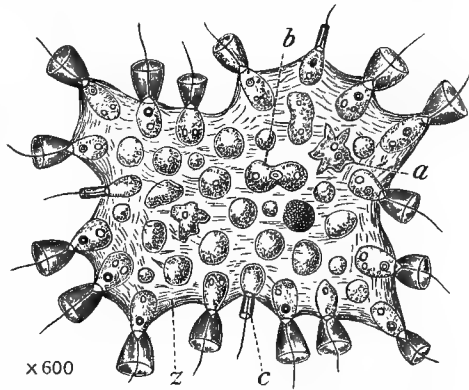

FIG. 61.

Proterospongia. $\times 600$. (From *The Cambridge Natural History*—after Saville Kent.) a, Amoebocyte; b, cell-individual undergoing fission; c, cell with small collar; z, jelly.

¹ These belong to the genera *Euspongia*—the finer-textured sponges, and *Hippospongia*—the coarser sponges, in which the body of the sponge is traversed by numerous wide branching channels in addition to the normal canal system.

stage in the evolution of choanoflagellate Protozoa in the direction of the Porifera.

BOOK FOR FURTHER STUDY

GENERAL TEXT-BOOK

Minchin. Porifera, in Lankester's Treatise on Zoology.

CHAPTER IV

ANNELIDA

IN the simple metazoan type represented by *Hydra* we saw that the body consists of the two primary cell-layers or epithelia—the ectoderm and the endoderm.

In the slightly more complex type represented by the sea-anemone the body still consists for the most part of the two primary layers but there are now apparent two advances in detail. (1) The endoderm bulges outwards to form the lining of the recesses or pockets lying between the mesenteries and (2) the mesogloea, the jelly-like material lying between the two primary layers, has become colonized by cells which have wandered into it by amoeboid movement. These immigrant amoebocytes constitute a new element in the structure of the body known as the **mesenchyme**.

In the still more complex type of structure characteristic of the great majority of the more highly evolved animals, grouped together under the common name COELOMATA, we find each of the two peculiarities just mentioned showing further development. The endoderm pockets have become separated off to form a body-cavity, known as the **coelome**, surrounding a central tubular **enteron** or alimentary canal. The lining of these coelomic cavities, originally part of the endoderm, is now distinguished from the definitive endoderm (lining the enteron) under the name **mesoderm**: it gives rise to the greater part of the muscles of the body and of the excretory and reproductive organs.

The mesenchyme again has become much more abundant. Indeed in the more bulky animals mesoderm and mesenchyme are responsible for by far the greater part of the body. Apart from the nervous system, which may be of considerable bulk, the ectoderm is confined to a thin layer covering the surface of the skin while the endoderm is similarly confined to a thin layer lining the alimentary canal.

Not only has the mesenchyme increased greatly in quantity: it

has also become highly specialized in various directions. Much of it forms packing or **connective tissue** and special tracts of this may become hardened and stiffened to constitute the skeleton. Other tracts of it form the blood-system. A large section of the mesenchyme remains on the other hand comparatively unspecialized as a mobile defence force to the body. Its cells retain the character of amoebocytes, creeping about among the tissues of the body, performing scavenging and other important functions and remaining permanently mobilized, ready to concentrate and attack alien organisms, such as disease-producing microbes, which have found their way into the body.

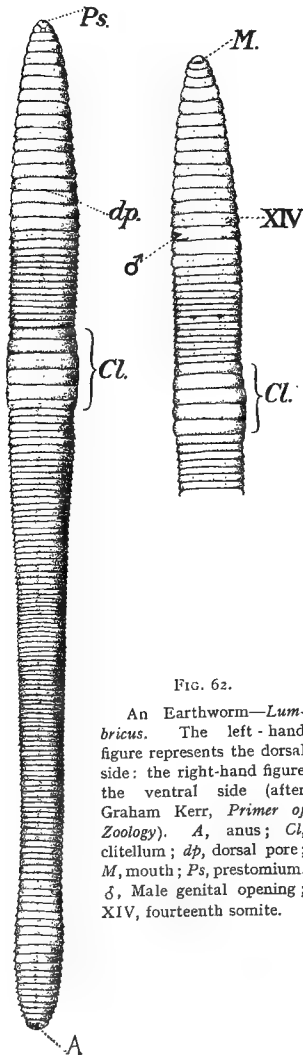

FIG. 62.

An Earthworm—*Lumbricus*. The left-hand figure represents the dorsal side: the right-hand figure the ventral side (after Graham Kerr, *Primer of Zoology*). A, anus; Cl, clitellum; dp, dorsal pore; M, mouth; Ps, prestomium. ♂, Male genital opening; XIV, fourteenth somite.

LUMBRICUS

The general features of the phylum ANNELIDA are conveniently studied in a large earthworm of the genus *Lumbricus* which, though not so unspecialized as are some of the marine annelids, has the advantage of being almost everywhere obtainable and of being thoroughly suitable for dissection.

The general appearance of the creature (Fig. 62) is familiar to every one — rounded in section, pointed towards the front or head end, flattened from above downwards towards the hinder end. The upper or **dorsal** side is darker in colour, the lower or **ventral** side is paler, and is somewhat flattened. Sharply marked

circular grooves on the surface of the body divide it into a large number of segments or **somites**. The general surface is covered with a thin, translucent, somewhat iridescent, cuticle which is apt

to strip off when the dead worm has been for some time submerged under water in the dissecting dish. Projecting slightly from the surface of the body are minute stiff bristles or **chaetae**. Of these there are in each somite eight, arranged in four pairs in a transverse row round the ventral half of the segment. They are most easily detected in the posterior flattened portion of the body and may be felt

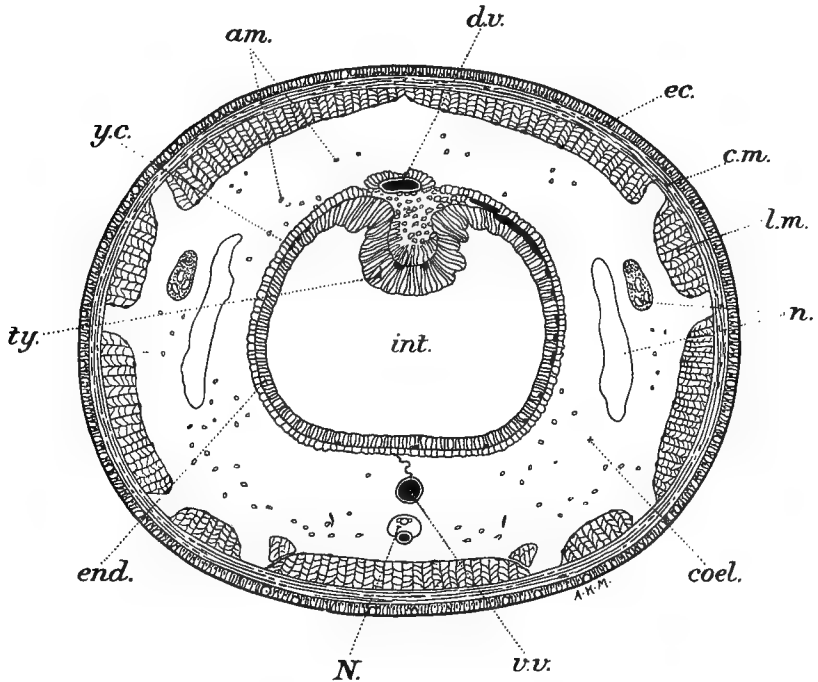

FIG. 63.

Lumbricus, transverse section about the middle of the body. *am*, Amoebocytes; *c.m.*, circular muscles; *coel.*, coelome; *d.v.*, dorsal blood-vessel; *ec.*, epidermis; *end.*, endoderm; *int.*, intestine; *l.m.*, longitudinal muscles; *N.*, ventral nerve-cord; *n.*, nephridium; *ty.*, typhlosole; *v.v.*, ventral vessel; *y.c.*, yellow cells.

[The cavities of blood-vessels are shown in black.]

by a sensitive finger passed along the surface of the body, or seen with the aid of a lens.

At the front end of the earthworm is the wide mouth opening (Fig. 62, *M*), overhung by a fleshy projecting lobe—the **prestimium** (*Ps*). At the extreme posterior end of the body is a vertical slit—the **anus** (*A*) or posterior opening of the alimentary canal.

Finally, if the worm be sexually mature, a distinct pale coloured and somewhat saddle-shaped swelling (Fig. 62, *Cl*) is seen encircling the

body, except on its ventral side, towards its anterior end. This thickening is the **elitellum**; it varies somewhat in position in different species of earthworm (Somites XXXII-XXXVII in *L. herculeus*, one of our commonest large earthworms) and as will be seen later it performs an important function in connexion with reproduction.

The body-wall of the worm is, as may be seen by examining transverse sections with the microscope, of complicated structure (Fig. 63). Externally is the ectoderm or **epidermis** (Figs. 63 and 64, *ec*) a layer of epithelium, the individual cells of which are columnar in shape and have the superficial layer of their cytoplasm condensed to form the cuticle which passes uninterruptedly from cell to cell. Here and there may be

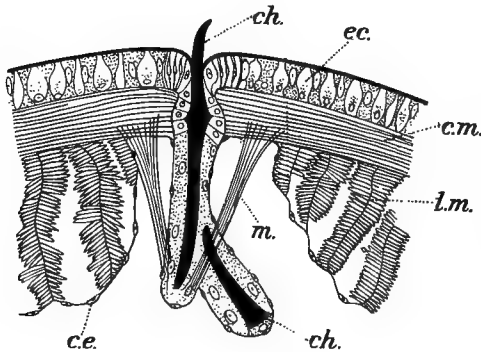

FIG. 64.

Portion of transverse section of an earthworm passing through a chaeta (after Vejdovsky). *c.e.*, Coelomic epithelium; *c.m.*, circular muscles; *ch.*, chaeta; *ec.*, epidermis; *l.m.*, longitudinal muscles; *m.*, muscle for moving chaeta. [The cuticle is indicated by a thick black line.]

seen a gland-cell—its cytoplasm laden with drops of secretion, its nucleus situated deep down towards its inner end, and its outer end tapering off to a comparatively narrow tip which is devoid of cuticle. The cuticle is thus incomplete, or perforated by a minute pore over each gland-cell, so that the secretion passes away readily on to the outer surface of the skin which it serves to

keep moist. Should the section pass longitudinally through a chaeta (Fig. 64) it may demonstrate the interesting fact that the chaeta is simply a small patch of cuticle enormously thickened so that it projects on the one hand outwards beyond the general surface and, on the other, downwards into the thickness of the body-wall. The inwardly projecting part of the chaeta is ensheathed in an epidermal pocket—the **chaeta sac**—and the chaeta is in fact the cuticle secreted by the epidermis forming the chaeta sac. Chaetae are liable to be worn out and shed, and in order to provide for this contingency a young reserve chaeta is formed by an outgrowth of the main chaeta sac (Fig. 64). If the main chaeta is lost, the reserve chaeta commences to grow actively and soon takes its place.

The greater part of the thickness of the body-wall is occupied by muscle fibres, which are arranged in two sharply defined layers, an outer layer of circular (*c.m*) and an inner layer of longitudinal fibres (*l.m*). The latter have a very characteristic appearance in a transverse section, owing to the contractile substance of each fibre being arranged in a curious pinnate pattern. When the longitudinal muscles contract they cause the body of the worm to shorten and thicken, while on the other hand the circular muscles by their contraction cause the body to diminish in diameter and consequently to increase in length. Amongst and around the muscle fibres is a small amount of packing or connective tissue, and finally the inner face of the body-wall is lined with a layer of extremely thin flat cells—the **coelomic epithelium** (Fig. 64, *c.e*).

The body-wall, the structure of which has been described, forms an outer tube and within this there runs from end to end of the worm an inner tube which is the enteron or alimentary canal (Fig. 63, *int*). The wall of this is composed of elements similar to those which constitute the body-wall only arranged in reverse order. Internally is a layer of columnar epithelium—the endoderm (*end*), outside this is a layer of circular and then a layer of longitudinal muscle fibres—both very thin, and finally a layer of coelomic epithelium (*y.c*). The tube so constituted is seen on slitting open the body-wall of the worm to consist of several regions of distinctive appearance (Fig. 65, A).

The **buccal cavity**—the cavity of the mouth (*b.c*)—leads into the somewhat ellipsoidal **pharynx** (*ph*) of characteristically furry appearance owing to the presence of numerous slender muscles which radiate out from it to the body-wall. These muscles when they contract serve to dilate the pharynx and in this way produce a sucking action by which food particles are drawn in through the mouth. The pharynx is continued back by a slender tube—the **oesophagus** or gullet (*oes*)—which about segment XIV dilates to form the somewhat conical **crop** (*c*). This in turn opens into the **gizzard** (*g*), about the same size as the crop but differing from it in its walls being thick and hard, due to the exaggerated thickness of the muscular layers. The gizzard stretches through about three somites and then is continued onwards as the **intestine** (*int*) which extends without further change to the anus at the hind end of the body. The intestine is of characteristic appearance, its wall is thin and sacculated, it has a brownish-yellow colour, owing to the peculiar nature of the coelomic epithelium covering it, and along the mid-dorsal line its wall projects inwards as a prominent fold—the **typhlosole** (Fig. 63, *ty*).

The main functions of the enteron are concerned with the ingestion, digestion, and assimilation, of the food. The food drawn into the

pharynx is passed onwards by what are termed **peristaltic** contractions of the enteric wall, waves of constriction—produced by the contraction

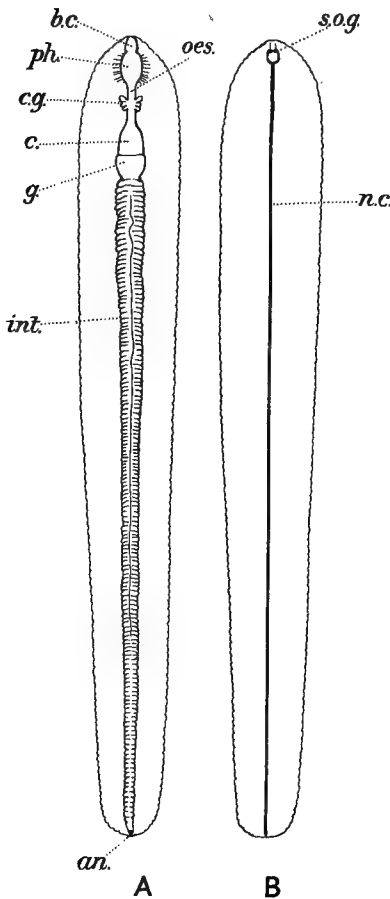

FIG. 65.

Dissections of *Lumbricus*, seen from the dorsal side. A, to show alimentary canal; B, to show central nervous system. *an*, Anus; *b.c.*, buccal cavity; *c.*, crop; *c.g.*, calciferous glands; *g.*, gizzard; *int.*, intestine; *n.c.*, nerve-cord; *oes.*, oesophagus; *ph.*, pharynx; *s.o.g.*, supra-oesophageal ganglia.

in succession of the circular muscles — passing tailwards and pushing the contained food in the same direction. In the gizzard, where the muscular coat is specially developed, the food undergoes a process of grinding into pulp. The food during its onward progress is subjected to the action of various secretions. The actual process of digestion is mainly carried out in the intestine and the digestive ferments are produced by gland-cells which are scattered about in the endoderm and pour their secretions into the intestinal cavity. In the region of the oesophagus (about segments X-XII) special collections of gland-cells are found in three pocket-like outpushings of the enteric wall (Fig. 65, A, *c.g.*). These are the **calciferous** glands, so called from the nature of their secretion — calcium carbonate — which gives the glands a very characteristic white chalky appearance. The function of this secretion is apparently to neutralize the free acid so frequently present in the soil which the worm ingests.

Between the enteric wall and the body-wall is the wide body-cavity or coelome (Fig. 63, *coel*), divided into numerous compartments—one to each somite—separated by thin transverse membranous partitions or septa, and

filled with a watery **coelomic fluid** in which creep about numerous amoebocytes (*am*). These amoebocytes constitute the mobile defence force alluded to on p. 130, they are physiologically **phagocytes**, i.e. their function is to devour and destroy noxious foreign particles such as bacteria which may have penetrated into the body of the worm. The coelomic cavities are bounded all round by the coelomic epithelium already mentioned. For the most part this consists of very thin flat cells, but on the outer surface of the intestine, and also over the surface of some of the blood-vessels, these are modified as **yellow cells** (Fig. 63, *y.c.*)—compactly shaped cells whose cytoplasm deposits within itself granules of yellowish-brown excretory material which gives the cell its characteristic colour. As the amount of this excretory substance increases

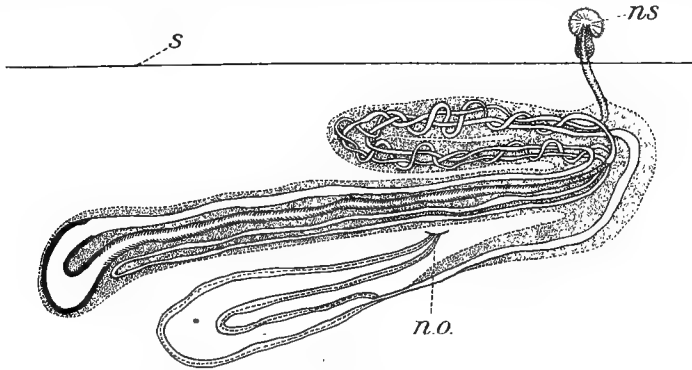

FIG. 66.

A nephridium of the Earthworm (after Maziarski). *n.o.*, External opening; *ns*, nephrostome; *s*, septum.

the cell-body may become so clogged up that life is no longer possible, the cell becomes moribund, it dies and disintegrates, and its remains are partially disposed of by the phagocytes, partly conveyed to the exterior by other means presently to be mentioned.

A typical coelomic compartment is not completely closed but communicates with the outer world by three openings. Two of these are paired and form the kidney tubules or renal tubules—known technically as the **nephridia** (Fig. 67, *n*).

Of these nephridia there is a pair in each somite except the first three and the last. The nephridium is a coiled slender tube (Fig. 66). At its inner end it communicates with the coelomic cavity by a richly ciliated coelomic funnel or **nephrostome** (Fig. 66, *ns*) while at its outer it opens (*n.o.*) on the surface of the body somewhat ventrally and laterally. The

nephridium is really embedded in the septum, the substance of which it causes to bulge freely into the neighbouring cavities—the funnel into the compartment in front of the septum, the main part of the nephridium into the compartment behind. The portion of nephridium next the external opening consists of a tubular bladder or reservoir with muscular walls—a favourite haunt of small parasitic nematode worms. The remainder, apart from the funnel, consists of a protoplasmic strand containing scattered nuclei, through which passes backwards and forwards, folded twice upon itself, a tubular cavity, varying in diameter in different regions and bearing over great parts of its inner surface actively moving cilia.

The function of the nephridium is a renal or excretory one and it performs this function in two ways. (1) The wall of the nephridium is richly supplied with blood by numerous vessels, and as the blood circulates through these, the protoplasm of the nephridial wall extracts from it the nitrogenous waste products of metabolism and passes them on into the tubular cavity. (2) The cilia of the nephrostome cause a slow current of the watery coelomic fluid to set outwards through the funnel and down the cavity of the tube. This current serves to carry away excess of coelomic fluid and small particles of disintegrated yellow cells which may be floating about in it. The outgoing stream also incidentally assists the first-mentioned function, inasmuch as it serves to flush out the excretory substances passed into the cavity of the nephridium by the activity of its wall.

The other communications between the coelome and the exterior are much simpler than those afforded by the nephridia, being in the form of direct openings in the mid-dorsal line known as the **dorsal pores** (Fig. 62, *dp*). The dorsal pore is situated close to the anterior boundary of the somite, immediately behind the septum, so that its external opening lies in the groove which demarcates its somite from that immediately in front of it. A dorsal pore occurs in each somite except the first ten. Light is thrown on the function of the dorsal pores if a small drop of some irritating substance is placed on the skin of a live worm. Drops of milky coelomic fluid are seen to exude from the dorsal pores in the neighbourhood so as to wash away the irritant. If the irritating substance be a little drop of a culture of some irritating bacterium the amoebocytes in the exuded drop of coelomic fluid attack the bacteria and ingest them. No doubt the dorsal pores play an important part in the protection of the skin against the attacks of bacteria or other injurious organisms by allowing free egress for coelomic fluid containing the defensive amoebocytes.

The body of a Metazoon like the earthworm, composed of myriads of cells all descended from one ancestral cell (the Zygote), is comparable with a brood of Protozoa derived from a single ancestor. As in the case of the Protozoon the process of syngamy when it takes place must as a rule take place between cell-individuals not belonging to the same brood. Ordinarily this is ensured by the gametes, the only cell-individuals capable of conjugating, being specialized into two different kinds—micro- and macrogametes—one of each being necessary for the process of syngamy, and by the gametes of any one individual being all of the one type. Occasionally however we find a particular species of animal in which the individuals are hermaphrodite—producing both male and female gametes. In such cases the possibility of conjugation is commonly guarded against in one of the following two ways. Either the male and female gametes develop at different periods, so that at any one time the individual is functionally of only one sex, or more or less complicated topographical arrangements exist whereby the two sets of gametes are kept rigidly apart. *Lumbricus* is hermaphrodite and it belongs to the second of these two categories.

The gonad consists, as is typically the case in animals which possess a coelome, of localized thickenings of the coelomic epithelium. Of these there are six, one pair of ovaries and two pairs of testes. The ovaries (Fig. 67, *ov*) are situated on the posterior face of the septum between somites XII and XIII, near its ventral edge and close to the median plane. When fully developed they are small pear-shaped bodies, attached by their base to the septum and tapering off into a fine filament which hangs freely into the coelome of somite XIII. Microscopic examination shows that this terminal filament is composed mainly of the eggs which have reached their full size and are ready to drop off into the coelome. The broader attached end is composed of small cells, which multiply actively and which have not yet assumed the characteristics of the fully formed gametes. The testes (Fig. 67, *t*) are very small lobed bodies which project back into the coelome of somites X and XI from the septa which bound these compartments in front. They are small and inconspicuous, partly owing to the coelomic space into which they project being filled with a dense mass of gametes in all stages of development. These various stages can be seen by examining a drop of the milky mass with the microscope. The earliest stages as shed from the testis are rounded cells. The nucleus of the cell divides and the cytoplasm becomes constricted into two halves which however remain connected by a thick bridge of cytoplasm. The processes of division of the nuclei and constriction of the cytoplasm are repeated over and over again, the end

result being a large number of small rounded blobs of cytoplasm each containing a nucleus and all connected together by a common mass of protoplasm in the centre. The central cytoplasm has increased much in size and forms a large spherical mass the surface of which is covered by the little round masses already mentioned so that the whole looks like a minute raspberry or mulberry. This stage is the sperm-morula referred to on p. 52 (see Fig. 21, A). With further development the small

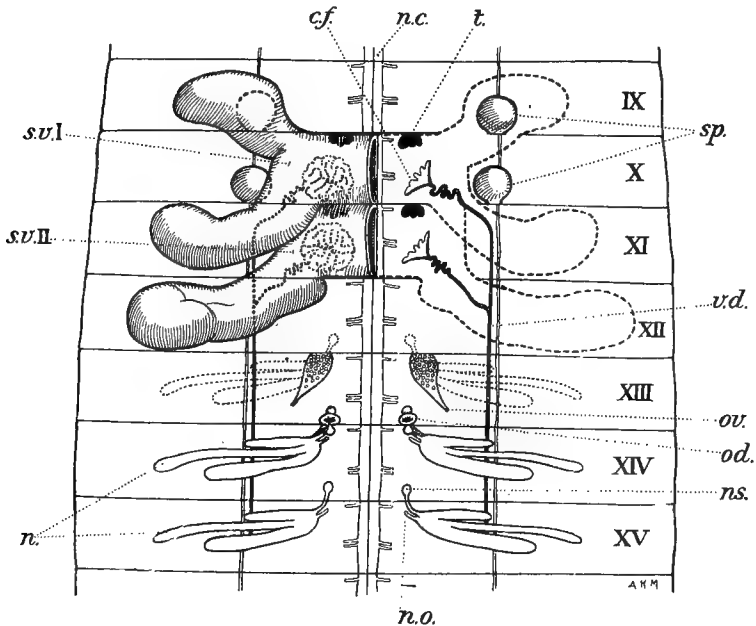

FIG. 67.

Lumbricus. Plan of genital organs, nephridia, etc. *c.f.*, Coelomic funnel of male genital duct; *n.*, nephridium; *n.c.*, nerve-cord; *n.o.*, external opening of nephridium; *ns.*, nephrostome; *od.*, coelomic funnel of oviduct; *ov.*, ovary; *sp.*, spermathecae; *s.v.I.*, anterior seminal vesicle; *s.v.II.*, posterior seminal vesicle; *t.*, testis; *v.d.*, vas deferens.

rounded bodies become pear-shaped, their outer ends becoming pointed. Later on they become drawn out into fine filaments, the inner thicker portion composed of the condensed nuclear material, the outer composed of cytoplasm highly contractile and capable of active flexure from side to side. Finally they break off as complete microgametes or spermatozoa and swim actively by the movements of their contractile "tails."

The spermatozoa like the eggs lie in the cavity of the coelome but, in correlation with their small size and active movements, they are

imprisoned in a special chamber which becomes cut off from the main cavity of the somite. This chamber is the **seminal vesicle**.¹ A seminal vesicle is formed in each of the somites (X and XI) in which testes are present (Fig. 67, *s.v.I.* and *s.v.II.*). Each is like a rectangular box walled in by thin membrane, the anterior and posterior walls being simply portions of septa. As the quantity of developing microgametes within the vesicle increases in amount the walls of the vesicle bulge outwards at their lateral angles forming large pouches, three on each side, which pushing the septa in front of them project into the cavities of neighbouring somites and in a dissection form the most conspicuous parts of the vesicles. Of these lateral pouches the anterior vesicle forms two pairs—one from each angle—while the posterior vesicle forms only a single pair—which are however the largest—from its posterior angles.

From the coelomic cavity the gametes find their way to the exterior through the paired **genital ducts**. These are simplest in the case of the female organs. The duct—**oviduct** (Fig. 67, *od*)—is in this case a short somewhat trumpet-shaped tube opening by a wide funnel-like mouth through the septum bounding somite XIII on its posterior side, and passing outwards and tailwards to open to the exterior by a minute slit on the ventral surface of somite XIV. The trumpet-shaped coelomic funnel of the oviduct bulges backwards on its inner side into segment XIV as a rounded pocket—the **receptaculum ovarum**—in which eggs accumulate and remain for a time before passing to the exterior.

The male gametes reach the exterior on each side by a slit-like opening with tumid lips on the ventral surface of somite XV (Fig. 62, ♂). The genital duct can be traced forwards from this as a straight slender tube—the **vas deferens** (Fig. 67, *v.d*)—very inconspicuous except when filled with spermatozoa—more or less embedded in the inner layers of the body-wall. Into the anterior end of this there opens a **vas efferens**, a slender contorted tube which comes to it from the anterior seminal vesicle and, one segment further back, a similar vas efferens comes from the posterior vesicle. Each vas efferens communicates with the cavity of the vesicle by a very wide **ciliated funnel** (Fig. 67, *c.f*), the wall of which is deeply frilled, folded backwards and forwards, so as to break up the mouth of the funnel into a system of very fine chinks. These chinks are so narrow that the sperm-morulae and other stages in the development of the microgametes are effectively prevented from passing out, whereas the

¹ This name has unfortunately come into practically universal use. The earlier naturalists more correctly applied the name *testis* to the whole cavity full of developing microgametes instead of restricting it to the small mass of germ-cells still attached to the lining of the cavity.

hairlike mature microgamete can readily pass down the chinks and so to the exterior.

There remain to be mentioned as accessory reproductive organs the two pairs of **spermathecae** (Fig. 67, *sp*). These are inpushings of the body-wall in the grooves between somites IX and X, and X and XI, which form spherical pockets projecting forwards into the cavity of somites IX and X respectively, and which functionally serve as receptacles in which microgametes received from another worm are stored until needed for the process of syngamy. When filled with spermatozoa they are conspicuous by the brilliant white appearance due to reflection of light from the surfaces of the dense nuclear portions of the innumerable microgametes.

The complicated arrangement of organs which has just been described has for its object the production of zygotes—new individuals in the unicellular stage. When the worm is about to lay its eggs the gland-cells of the clitellum become active and produce a liquid secretion which spreads over the surface of the clitellum and there hardens to form an elastic membrane encircling the clitellar region of the body like a piece of stretched indiarubber tubing. The worm next proceeds by writhing movements to work itself backwards out of this elastic sheath. As the sheath passes over somite XIV the macrogametes (commonly about four in number) from the two receptacula are passed outwards so that they lie between the sheath and the body. At the level of somites XI to IX mature microgametes from the spermathecae—received it will be remembered from another worm—are squeezed out into the same space. Finally as the worm withdraws its head end from the elastic sheath the ends of the latter close up and it forms a small lemon-shaped **cocoon**. Each egg or macrogamete within the cocoon is fertilized by a microgamete and one or more of the zygotes so produced proceeds to develop into a new individual, the remainder degenerating.

The earthworm possesses a well-developed blood-system. Of the vessels the two most conspicuous are longitudinal—the **dorsal vessel** (Fig. 63, *d.v*), more or less hidden amongst the yellow cells on the dorsal surface of the alimentary canal, and the **ventral vessel** (*v.v*) suspended by a thin membrane underneath the alimentary canal. These vessels are connected by large hoop-like vessels in about five somites (VII to XI) towards the front end of the worm, which from their function are known as the **hearts**. Connected with these main blood-vessels are numerous smaller vessels which divide into smaller and smaller branches and lead eventually into a network of extremely fine, thin-walled, **capillary** blood-vessels in which the blood is brought into

extremely close relations with the living protoplasm of the various organs of the body. The capillary network is well seen in the wall of the alimentary canal, immediately outside the endoderm, where it is concerned with the taking up of the products of digestion, in the wall of the nephridium where it is concerned with excretion, and immediately beneath the epidermis where it is concerned with respiration. From the capillary network the blood drains away into small vessels which uniting together in a branched system return it eventually into the main vessels.

The blood is propelled onwards by waves of peristaltic contraction of the walls of the larger vessels. These are particularly accentuated in the hearts, in which the peristaltic waves pass downwards from dorsal to ventral end. The hearts being situated towards the head end of the worm it follows that the blood-stream passes forwards in the dorsal vessel, ventralwards in the hearts, and tailwards in the ventral vessel.

The blood itself consists of small irregular or rounded cells floating in a copious fluid or **plasma**. The latter is coloured "blood-red" owing to its carrying in solution the same iron-containing colouring matter—**haemoglobin**—as gives the red colour to the blood of Vertebrates. This substance haemoglobin is intimately concerned with the process of respiration. It has a great affinity for oxygen and if brought into relation with it at once combines with it to form **oxyhaemoglobin** characterized by its bright red colour. The oxygen and the haemoglobin in this compound are combined in a very loose fashion and are readily torn apart. It is this chemical characteristic that enables the haemoglobin to perform its great physiological function, that of acting as a vehicle for the oxygen so necessary for the metabolism of all the living protoplasm of the body. As the blood circulates through the capillary network of the skin the haemoglobin combines with the oxygen which diffuses in from the outer air. The oxyhaemoglobin so formed is then whirled away in the blood-stream until, somewhere in the interior of the body, coming into the neighbourhood of tissues hungry for oxygen, it breaks up, sets free its oxygen, so that it can be appropriated by the tissue, and passes onwards as reduced haemoglobin until it undergoes re-oxygenation on again passing near the surface of the body.

There finally remains to be mentioned the nervous system which serves to control the activity of the worm and to knit together its constituent parts into a coherent and functional whole. The most important change which we see when we compare higher stages in the evolution of the nervous system with lower consists in the greater centralization of control, correlated with greater concentration of ganglion-cells, so

that a **central** part of the nervous system becomes more and more sharply marked off from a **peripheral** portion which, composed mainly of nerve-fibres, serves merely to convey the nerve impulses to or from the nerve centres. In this respect the nervous system of the earthworm shows a very marked advance on that of a Coelenterate, inasmuch as the central portion of the nervous system is sharply marked off and comparatively highly developed. It consists firstly of a longitudinal strand—the **ventral nerve-cord**—which runs throughout the length of the worm in the mid-ventral line and immediately internal to the body-wall (Fig. 65, B, *n.c.*, and Fig. 63, *N*). In each somite the cord is slightly swollen—these swellings or **ganglia** being simply portions of the cord in which there is a specially marked aggregation of ganglion-cells. From each ganglion there pass off to each side slender **nerves**, i.e. bundles of nerve-fibres, some of which are motor, connected with the muscles of the body-wall, while others are sensory, ending in sensory cells in the epidermis.

Secondly, in addition to the ganglia of the ventral cord there are present a pair of ganglia (**cerebral**, or **supra-oesophageal** ganglia—Fig. 65, B, *s.o.g.*), which lie side by side, dorsal to the pharynx and close to its front end. These are continuous with one another through a thick **commissure** or bridge of nerve-fibres, while each is also continued at its outer side into a **circum-oesophageal** commissure which curves round the side of the alimentary canal and is continued ventrally into the first ganglion of the ventral cord. From the cerebral ganglion on each side there passes forwards a conspicuous little nerve consisting mainly of sensory fibres connected with sensory cells in the epidermis of the prestomium, this latter being an extremely sensitive organ by which the worm, so to speak, feels its way when burrowing through the earth.

The study of the Earthworm serves to illustrate a number of important general principles of animal structure. The Coelenterates and Sponges are creatures either **sessile** in habit (i.e. fixed in one spot) or capable of only comparatively sluggish and indeterminate movements. The worm on the other hand moves about actively and its movements are determined in relation to the structure of its body—one particular end always going in front under normal circumstances, and one particular side being above. Correlated with this type of movement, the body of the creature has undergone adaptive evolution in its general structure. It has become elongated in the line of movement. Its two ends have become differentiated—though not so markedly as in many other worms

—into an anterior or head end, carrying the mouth, the sensitive pre-stomium and the cerebral ganglia, and a posterior end carrying the anus. Again, the side which is normally uppermost (dorsal side) is differentiated from the side which is normally below (ventral). The general symmetry of the worm is **bilateral**, i.e. with the right and left side alike and equal, in contradistinction to such creatures as Hydroids or Medusae in which there is **radial** symmetry. Such bilateral symmetry is usual in animals which move actively forwards, while radial symmetry on the other hand is associated with a sessile or drifting habit. Lastly the worm affords a good example of **metamerism** or **metameric segmentation**, i.e. the subdivision of the body into successive somites, each a repetition of the others in its main structural features—body-wall with dorsal pore and chaetae, coelomic compartment, pair of nephridia, nerve ganglion, etc.

Portions of an animal (or of different animals) which are morphologically equivalent, built up out of the same elements, are said to be **homologous**. Thus the fore-limb is homologous in the various types of vertebrate—the fore-leg of a lizard, the wing of a bird, the fore-leg of a dog, the wing of a bat, the flipper of a whale, the arm and hand of a man—these, in spite of their dissimilarity in appearance and in function, are homologous, for they correspond in structure and have arisen in evolution from the fore-limb of the common ancestor. This adjective homologous must be carefully distinguished from **analogous** which is used to express functional not structural correspondence. Thus the wings of a Fly and a Bird are analogous organs for they serve the same function but they are not homologous for there is no structural or evolutionary correspondence.

Again, a nephridium of one worm is homologous with that of another. Even within the body of the same animal organs may be homologous, e.g. organs on one side of the body are homologous with their fellows on the other. Or in the case of a metamericly segmented creature they may be homologous with their representatives further forward or back in the series. In this case the expression **serial homology** (or homodynamy) is used: thus the individual somites of the worm are said to be serially homologous.

The last great difference between the worm and the coelenterate is that whereas the latter has, interposed between the two primary layers of cells, a mere structureless mesogloea, with at the most a few scattered immigrant cells, the worm has on the other hand interposed between ectoderm and endoderm the complicated arrangements of tissue constituting the mesoderm and mesenchyme. From the worm upwards, throughout the animal kingdom, these constitute, as indicated at the

commencement of this chapter, by far the greater part of the bulk of the body—in fact everything except the thin layer of endoderm lining the

alimentary canal, the thin ectoderm or epidermis covering the outer surface, and the nervous system. In the worm and in the large variety of animals grouped together as the Coelomata the mesoderm is excavated to form the coelomic body-cavity. This may be defined as “a body-cavity lined by mesoderm, communicating with the exterior by nephridia and developing the gonad from its lining epithelium.”

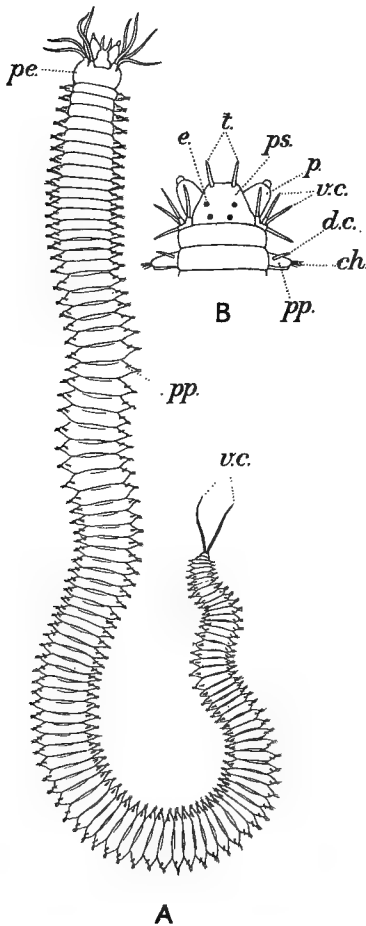

FIG. 68.

Nereis. A, View of entire worm from the dorsal side (after M'Intosh); B, enlarged view of head region of a different species of *Nereis* to show details. *ch*, Chaetae; *dc*, dorsal cirrus; *e*, eye; *p*, palp; *pe*, peristomium; *pp*, parapodium; *ps*, prestomium; *t*, prestomial tentacles; *uc*, ventral cirri.

The phylum ANNELIDA is subdivided into three sections (1) Polychaeta, (2) Oligochaeta, (3) Hirudinea.

I. POLYCHAETA

The general features of the Polychaeta are well illustrated by *Nereis*—the Ragworm (Fig. 68)—of which several species are common round our coasts under stones or amongst sandy mud. The first striking difference in appearance from *Lumbricus* is afforded by the presence of numerous rude leg-like projections—the **parapodia** (*pp*)—arranged down the sides of the body—a pair to each somite. If a thick transverse section of the worm is made so as to show a parapodium from its anterior or posterior side (Fig. 69) it is seen that the parapodium is bilobed—the dorsal lobe being the **notopodium** and the ventral the **neuropodium**.

At the base of each of these lobes there projects from the surface of the body a tentacle-like projection or **cirrus**—known respectively as the notopodial cirrus (*d.c.*) and the neuropodial cirrus (*v.c.*). Further each lobe has embedded in it a bundle of numerous chaetae, larger and projecting further beyond the surface than those of *Lumbricus*. One of the chaetae near the centre of each bunch is thicker and stouter than the rest. It is known as the **aciculum** (Fig. 69, *ac*) and its main function appears to be to act as a support to the parapodium.

At the front end of the *Nereis* there is a more pronounced development of head than is the case in *Lumbricus*. The prestomium is larger and more highly developed (Fig. 68, B, *ps*). A pair of **prestomial tentacles** (*t*) project from it in front while embedded in its dorsal wall

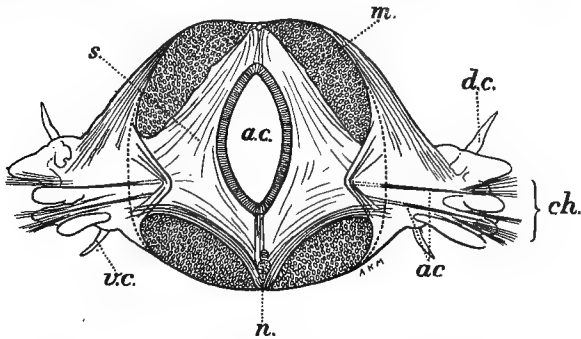

FIG. 69.

Isolated somite of *Nereis*. *a.c.*, Alimentary canal; *ac*, acicula; *ch*, chaetae; *d.c.*, notopodial cirrus; *m*, longitudinal muscle; *n*, nerve-cord; *s*, coelomic septum; *v.c.*, neuropodial cirrus.

are two pairs of eyes (*e*). On each side there projects a **palp** (*p*), a tentacular structure with a large base into which the terminal portion can be retracted telescope-fashion. Immediately behind the prestomium is the **peristomium** (Fig. 68, A, *pe*), representing two somites fused together, in correlation with which it bears four cirri on each side instead of only two; it has no projecting parapodia.

There are various features of interest to be noted in connexion with the reproductive phenomena of the Polychaetes. In *Nereis* itself the adult worm in some species assumes when sexually mature a peculiar change of form which before the life-history was understood caused it to be regarded as a separate genus to which the name *Heteronereis* was given. In the heteronereid condition the hinder part of the body, in which alone are gametes developed, becomes modified, its parapodia becoming enlarged and flattened, while chaetae of a curious

paddle-like form may make their appearance. These modifications of the parapodia have to do with the fact that the *Nereis* at this stage gives up its bottom-frequenting habit and swims about freely so as to distribute the gametes over a wider area. With the assumption of the pelagic habit there comes about another modification very usual in pelagic animals namely a great increase in the size of the eyes.

In an allied family of Polychaetes, the Syllidae, to which a number

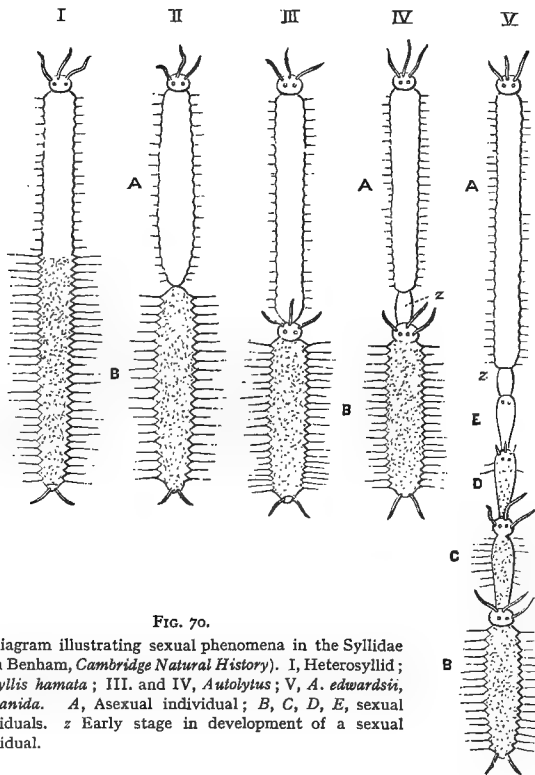

FIG. 70.

Diagram illustrating sexual phenomena in the Syllidae (from Benham, *Cambridge Natural History*). I, Heterosyllid; II, *Syllis hamata*; III. and IV, *Autolytus*; V, *A. edwardsii*, *Myrianida*. A, Asexual individual; B, C, D, E, sexual individuals. z Early stage in development of a sexual individual.

of common marine worms belong, there occur similar modifications, carried in some cases much further than in *Nereis*. In the simplest case (Fig. 70, I) what takes place is very much the same as in *Nereis*, a heterosyllid condition being assumed in which the hinder part of the body containing the gametes takes on an appearance markedly different from that of the front part. In exceptional species of *Syllis* (*S. hamata*) after the heterosyllid condition has been reached there makes its appear-

ance, just in front of the sexual region, a constriction of the body which gradually deepens so that the whole of this portion of the body becomes completely separated off (Fig. 70, II). This latter retains its vitality for some time, wriggling about and distributing the gametes. Another species of *Syllis* (*S. hyalina*) behaves in the same way as *S. hamata* but in this case the separated-off portion after a few days develops a definite head region so that it now forms a complete sexual individual. In various species of *Autolytus* the sexual individual develops its head before it separates off (Fig. 70, III) and further the process is repeated—new sexual individuals being produced in succession, each after its predecessor has separated off. In certain exceptional cases sexual individual No. 2 (Fig. 70, IV, z) develops before No. 1 separates off and this leads up to the condition met with in old specimens of *A. edwardsii* where as many as six new sexual individuals may be recognizable before the first-formed one has become detached (Fig. 70, V). In a closely allied genus, *Myrianida*, chains of as many as thirty sexual individuals have been observed—the youngest and least developed one in front—attached to the hinder end of the original individual. This latter is of course asexual, developing no gametes, though it may be said to reproduce asexually by the production of the new sexual individuals at its hinder end.

These reproductive peculiarities which find their climax in *Myrianida* are of special interest from their parallelism with phenomena characteristic of one of the great groups of parasitic worms dealt with in the next chapter—the Tapeworms or Cestoda.

While *Nereis* exemplifies satisfactorily a typical member of the Polychaeta there occur within the group many variations in details of structure. A general idea of the kind of variations met with is got by examining a few common marine genera. One of the features which is particularly apt to depart from the normal is the dorsal or notopodial cirrus. In *Cirratulus*, common amongst mud and sand under stones near low-water mark, the dorsal cirri are long and threadlike, twisting actively about in the live animal and functioning as gills. In *Eunice*—found in burrows in sand near low-water—the dorsal cirrus also functions as a gill but here it develops side branches so as to have a feathery appearance. In *Polynoe*—one of the commonest genera of marine worms—the back is covered by overlapping plates or **elytra**, each of which is really the greatly expanded tip of a notopodial cirrus which has grown out in mushroom fashion all round (Fig. 71, A, *d.c.*). In *Aphrodita*—the “Sea-mouse” to give it its somewhat absurd popular name—an

unusually bulky worm which attracts attention, when cast up on the shore, by the magnificent iridescence of its long chaetae, there exist quite similar elytra to those of *Polynoe* (Fig. 71, B, *d.c.*), only in this case they are not visible in surface view, being hidden away under curious tough felt. The nature of this is seen by studying a transverse section of the worm like that shown in the diagram (Fig. 71, B). It is seen that the notopodium does not project from the surface but its position is indicated by its chaetae. Of these there are three different sets. Furthest out are the long fine iridescent chaetae (1), which give the creature its characteristic appearance. To the inner side of these are short stiff black chaetae (2), and amongst these are produced the third set of chaetae

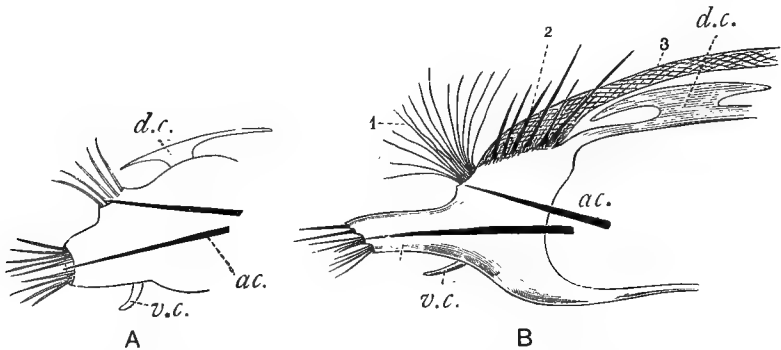

FIG. 71.

Diagram to illustrate the parapodium of *Polynoe* (A) and *Aphrodita* (B) (from Benham, *Cambridge Natural History*). *ac.*, Acicula; *d.c.*, dorsal cirrus; *v.c.*, ventral cirrus. 1, Iridescent chaetae; 2, stiff black chaetae; 3, felt.

which break up into their constituent fibres and become felted together to form a roof (3) which covers over the elytra.

In many cases the Polychaete shows peculiarities clearly related to peculiarities in its mode of life. For example *Tomopteris* lives a pelagic existence, swimming about in the surface waters of the sea. Its parapodia are long and paddle-like: their chaetae have disappeared except two on each side at the head end. As in so many pelagic creatures the body has developed a glassy transparency which makes it almost absolutely invisible when alive in the sea-water. Many Polychaetes live in burrows, such as the ordinary Lug-worm (*Arenicola*) which is responsible for the numerous heaped-up sand castings so commonly seen on flats of sandy mud between tide-marks. In it the parapodia are reduced in size so as to be quite inconspicuous and the neuropodium and notopodium are some distance apart. A number of the notopodia

carry conspicuous branched gills. These may be situated near the middle of the body—about a dozen pairs, the exact number differing in different species—or they may extend right back to the hinder end of the body as is the case with two species. A remarkable feature of *Arenicola*, very unusual amongst Polychaetes, is its possession of a pair of otocysts, lying one on each side close to the circum-oesophageal commissure and consisting of a tubular invagination of the outer surface, dilated at its inner end into a rounded cavity full of fluid and containing little grains of sand which act as otoliths.

Another very common inhabitant of sandy shores is *Terebella* which not only burrows in the sand but gives its burrow a certain degree of permanence by lining it with grains of sand, fragments of shell or even small pebbles, cemented together by secretion produced by conspicuous patches of gland-cells on the ventral surface of the anterior segments. In *Terebella* there is present a transverse row of long thread-like tentacles projecting from the dorsal surface of the prestomium. Each has a ciliated groove along its ventral side. When building its tube of sand-grains the *Terebella* stretches out its tentacles over the surface of the sand and grains are caught up and carried by ciliary movement along the groove in towards the head of the worm where they are built on to the edge of the tube. Normally the *Terebella* extends its tube so that it projects slightly above the surface of the sand, ending off in irregular branched threads of sand which often form conspicuous tufts studding the surface of the sand near low-water mark.

In the genus *Pectinaria* also a tube is built up of sand grains cemented together, in this case with great regularity, so as to form a slightly curved tapering "house" which the animal carries about with it. The tube is open at both ends the hinder opening being plugged by the flattened posterior end of the worm and the wider anterior opening being guarded by stout golden chaetae springing in a row from each side of the second segment.

Finally there exist a large series of Polychaetes which are still more intimately adapted to a tube-dwelling habit; the parapodia are in these greatly reduced, as is the prestomium with its tentacles, while on the other hand the palps are greatly enlarged, forming branched plume-like and often beautifully coloured gills. In *Serpula* and its allies the tube is composed of calcium carbonate with a slight organic basis of conchiolin (see p. 268) and a branch of one of the gills forms a conical stopper which plugs the mouth of the tube when the animal withdraws, as it does with lightning rapidity. A very common Serpulid is *Pomatoceros triqueter*, which forms the white tubes, with a longitudinal

ridge projecting into a spike over the opening, so frequently seen winding over the surface of stones and shells on the seashore. Another is the tiny *Spirorbis*, whose tube, coiled into a flat spiral, is so common on seaweeds and rocks. In this case the stopper is hollowed out to form a brood-cavity in which the eggs undergo part of their development. The genus *Sabella* and its allies resemble the Serpulids in their general character. One of their interesting features is their intense sensitiveness to light impressions—a shadow falling on the expanded worm causing it at once to draw back into its tube. This sensitiveness is due to sensory cells in the epidermis of the gills and in some of the allied genera such cells become clumped together to form definite and complicated eyes which show as round black dots on the gill. The genus *Sabella* itself lives embedded in mud, its vertical tube of mud grains projecting upwards beyond the general surface. Large worms of this genus a foot or so in length may be frequently found a little below low-water mark, e.g. in meadows of sea-grass in quiet bays and sea lochs.

DEVELOPMENT OF POLYGORDIUS

As an example of the mode of development of the marine annelids we will take the case of the little marine worm *Polygordius* a member of a small group of worms which on account of their very simple and primitive character are usually separated off from the typical Polychaetes as a group by themselves—the Archannelida.

At sexual maturity the body of the *Polygordius* breaks up and sets free the gametes, male or female as the case may be. Syngamy takes place in the sea-water and the zygote undergoes the usual process of segmentation giving rise to a blastula. The gastrula stage is reached by a process of invagination similar to that of *Aurelia* except that a relatively much smaller portion of the blastula-wall becomes involuted to form the archenteron. The opening of this, the protostoma, becomes elongated, taking on an elliptical shape, and then it narrows in the middle, its outline becoming that of a dumb-bell. Finally the side lips of the opening come together and completely fuse so that the elongated opening is now represented by two distinct openings some distance apart. Of these openings one persists as the mouth while the other, though it closes temporarily for a short time, is represented by the anus. Consequently these two openings in *Polygordius* are to be regarded simply as the end portions of the original protostoma, and there is reason to suspect from hints given us by the study of the development of various other animals that this represents the way in which the

mouth and anal openings of the more complicated animals in general have arisen in evolution—as the isolated and persisting ends of an elongated primitive mouth or protostoma of the type still existing at the present day in such an animal as a sea-anemone.

The young *Polygordius* gradually takes on the form of a very characteristic type of larva known as a **trochosphere** (Fig. 72, A). This is rounded in form, slightly pointed at its anal or posterior end, and pro-

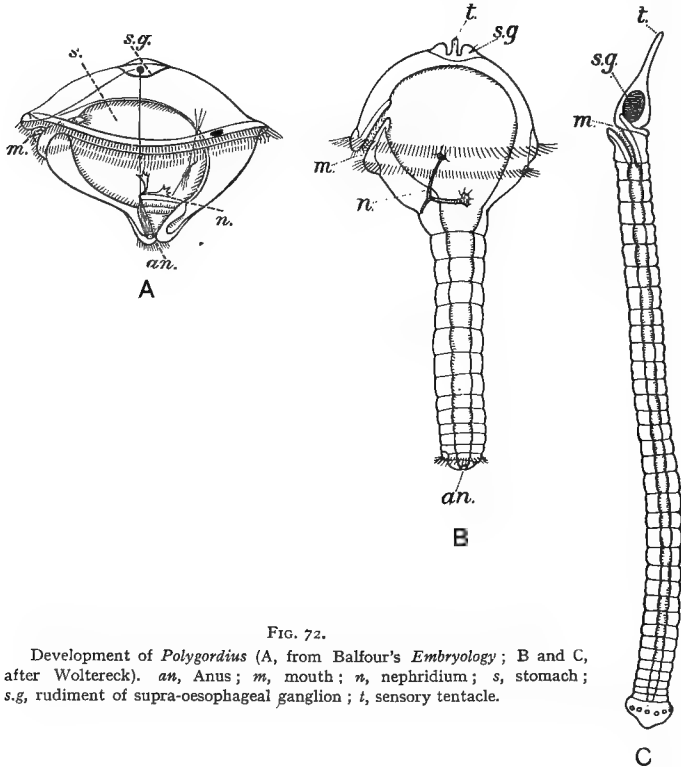

FIG. 72.

Development of *Polygordius* (A, from Balfour's *Embryology*; B and C, after Woltereck). *an.*, Anus; *m.*, mouth; *n.*, nephridium; *s.*, stomach; *s.g.*, rudiment of supra-oesophageal ganglion; *t.*, sensory tentacle.

jecting slightly round the equator. On one side (ventral) is the mouth opening (*m*) leading into the T-shaped alimentary canal. The middle part of this is dilated to form a stomach (*s*) while the oesophagus between the stomach and the mouth is lined by an ingrowth of ectoderm and is consequently stomodaeal in nature. The lining of the alimentary canal is ciliated, while on the outer surface there are powerful cilia round the equator, arranged in a double (pre-oral) band in front of the mouth and a row of smaller (post-oral) cilia behind the mouth, by the movements

of which the larva swims. At the apex of the dome-shaped pre-oral portion of the larva, which subsequent development proves to be the anterior end, there is a cushion-like thickening of the ectoderm (*s.g*) representing the nerve-centre or brain of the larva. Certain of the cells forming this project into the water as long sensory hairs, looking like stiff cilia and probably to be regarded as cilia which have lost their original motor function and taken on a new sensory one. Between the endoderm and ectoderm there is a wide space containing mesoderm cells, some scattered and others forming a compact band on each side. There is also present on each side a nephridium (*n*) of the primitive type known as **protonephridium** which instead of having an open nephrostome at its inner end is provided with the peculiar structures known as "flame-cells" which will be described in the next chapter (p. 161).

The trochosphere becomes converted into the fully formed adult in the way indicated by Figs. 72, B and C, the region round the anus growing out rapidly to form the body of the worm, while the main mass of the trochosphere becomes the head region. In fact the trochosphere larva might be described as the precociously developed and free-swimming head of the *Polygordius* !

The species of *Polygordius* which occurs in the North Sea and round the west coast of the British Isles shows a curious peculiarity in its development in that the trunk portion of the worm remains for a time folded up in concertina fashion within the body of the trochosphere.

In the typical Polychaeta the course of development is in general much as in *Polygordius*. There is typically a trochosphere larva although this may be modified in details such as its shape and more especially the arrangement of its cilia.

The main characteristics which serve collectively to mark off the Polychaeta as a distinct group of annelids are (1) the marine habit ; (2) the presence of groups of chaetae usually embedded in distinct parapodia ; (3) the well-developed head region usually provided with tentacles, palps, or other projections ; (4) the separate sexes ; and (5) the occurrence of a free-swimming larval stage.

II. OLIGOCHAETA

The group Oligochaeta includes the true Earthworms, of which a large number of species and genera are known, and also a number of

genera which are aquatic, living in the mud at the bottom of fresh water or, in a few cases, of the sea in close proximity to the coasts.

The general characteristics of the group are well exemplified by *Lumbricus*—the most important being the reduction in the number of the chaetae, the disappearance of the parapodia, tentacles and cirri, and the hermaphroditism with its correlated complexity of the reproductive organs. It is also characteristic, as is usually the case with groups originally marine which have taken to a fresh-water or terrestrial existence, that the active free-swimming larval stage has been eliminated from the life-history, early development taking place within the cocoon.

III. HIRUDINEA

As an example of the group Hirudinea it will be convenient to examine the ordinary leech used in medicine—belonging to the genus *Hirudo*. The leech is a somewhat flattened worm measuring commonly about 3 to 5 inches in length although varying greatly according to the state of extension or contraction of the body.

The colour is green or brown with dark mottlings. The whole body is marked off superficially into narrow rings or **annuli**, about 95 in all. At the hind end of the body is a powerful round **posterior sucker**, while at the front end the muscular lips of the wide mouth opening form an **anterior sucker**. There are no traces of parapodia or chaetae.

The alimentary canal of the leech is of special interest in its adaptations to the peculiar feeding habits—the food being blood, which can be obtained only at long and uncertain intervals. In the buccal cavity arranged in radiating fashion are three small saws (Fig. 73 A, *j*), each with a curved edge set with numerous small teeth of hard chitinous material. The saws are provided with muscles by which they can be rotated backwards and forwards so as to make a characteristic 3-rayed cut in the skin of the animal attacked. The buccal cavity leads into the pharynx (*ph*), ellipsoidal in shape and of furry appearance due to the radiating muscles which pass from its surface to the body-wall. These by their contraction cause the cavity of the pharynx to dilate and in this way bring about a sucking action through the mouth. The pharynx leads, with scarcely any intervening oesophagus, into an enormous crop furnished on each side with ten or eleven blindly ending pockets or **caeca** (*c*). These are least clearly marked in front, while on the other hand the hindmost caecum on each side is very large. The crop serves merely as a reservoir for the ingested blood, the actual digestion being carried out in the intestine (*int*)—the narrow tubular portion of the

alimentary canal which passes from crop to anus. The intestine is at its front end somewhat funnel-shaped, then it becomes slightly dilated, bulging outwards as a pair of small rounded caeca (*d.g.*). Behind these it forms a straight narrow tube which finally dilates somewhat to form

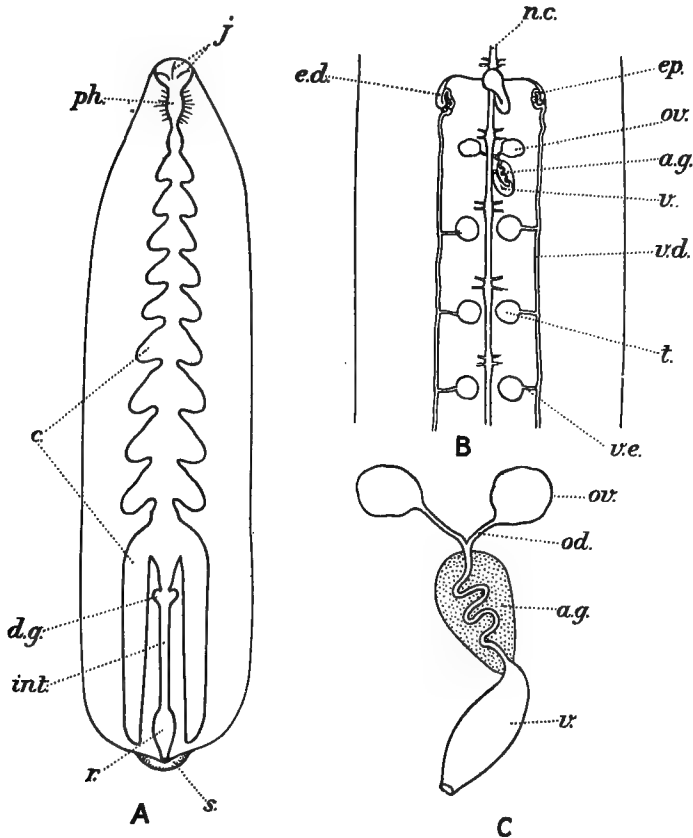

FIG. 73.

Hirudo. A, Alimentary canal; B, reproductive organs; C, enlarged view of female organs spread out in one plane. *a.g.*, Albumen gland; *c*, caeca of crop; *d.g.*, digestive caecum; *e.d.*, ejaculatory duct; *ep.*, epididymis; *int.*, intestine; *j.*, jaws; *n.c.*, nerve-cord; *od.*, oviduct; *ov.*, ovary; *ph.*, pharynx; *r.*, rectum; *s.*, posterior sucker; *t.*, testis; *v.*, vagina; *v.d.*, vas deferens; *v.e.*, vas efferens.

the rectum (*r.*), terminating in the anal opening, situated on the dorsal surface just in front of the posterior sucker.

The alimentary canal is as usual provided with definite glandular arrangements. Projecting from the wall of the pharynx are numerous

slender pear-shaped or club-shaped cells of great size. These are unicellular glands which discharge their secretion into the cavity of the pharynx, so that it mixes with the blood as it is being ingested. This secretion has the remarkable property of preventing the coagulation of blood, and owing to its presence the blood taken into the crop remains perfectly fluid and unclotted for weeks or even months, so that it can slowly pass onwards into the intestine to undergo the process of digestion. The actual digestive ferment is apparently secreted by the lining cells of the two rounded intestinal caeca (*d.g.*).

A characteristic feature of *Hirudo*, as of the majority of leeches, lies in the fact that the coelome is to a great extent obliterated, the open coelomic body-cavity seen in other annelids being replaced by a dense spongework. Here and there the cavity persists in the form of fluid-containing spaces or sinuses, one of which encloses the nerve-cord ventrally while another runs longitudinally in a dorsal position. Round the limit of the coelome, immediately underlying the body-wall, is a network of small tubular cavities characterized by the dark pigment in the tissue surrounding them—the **botryoidal** tissue.

A remarkable peculiarity of the coelomic fluid of *Hirudo* is that it is coloured red by the presence, in solution, of haemoglobin—the red iron-containing pigment which is present in the blood of various animals. It would appear from this that the coelomic fluid has in the leech taken over functions normally pertaining to the blood. The spongework of coelomic spaces with their contained coelomic fluid seem to have replaced the blood system functionally and in correlation with this the original blood-system seems to have to a great extent disappeared. Along each side of the body of the leech there runs a conspicuous lateral “blood-vessel” with contractile muscular walls but this communicates freely with the coelomic spaces and is filled with coelomic fluid and the probability seems to be that even it is not a true blood-vessel but merely a coelomic sinus with specially muscular wall.

The leech possesses normally seventeen pairs of nephridial tubes, the internal funnel of which is broken up into a spongework of fine pores and is contained in a special little coelomic cavity. Just before perforating the body-wall the nephridium dilates to form a bladder, spherical in shape when distended. The opening to the exterior is a minute pore situated laterally and on the ventral side of the leech. It can most easily be detected by the drop of fluid which oozes from it when the surface of the leech is carefully dried and the animal subjected to slight pressure. An important point to notice is that the nephridial openings over the greater part of the body occur on each fifth annulus—an indication of

the fact that a group of five of these annuli corresponds to a single complete somite of a Polychaete or Oligochaete.

The leech is hermaphrodite, the gonad being formed from the lining of little spherical coelomic chambers—nine (sometimes ten or eleven) pairs of testes (Fig. 73, B, *t*) situated ventrally on each side of the mesial plane, and a single pair of rather smaller rounded ovaries (*ov*) situated further forward. Ovaries and testes occur in successive somites, i.e. at a distance of five annuli from one another. As regards ducts, each ovary is prolonged into a slender oviduct (Fig. 73, C, *od*)—one or other of which passes under the ventral nerve-cord. The two ducts unite to form an unpaired oviduct which winds from side to side in the substance of a transparent-looking albumen-gland (*a.g*) and on emerging from this bends forward on itself and is continued as the thick-walled muscular vagina (*v*) to the median external opening. The eggs before being laid accumulate in the vagina and the inner portion of this organ is consequently sometimes termed the uterus.

Each testis is continued outwards into a minute vas efferens (Fig. 73, B, *v.e*) and these open at right angles into a longitudinal duct—the vas deferens (*v.d*). This extends forward to the level of the somite next in front of the ovaries where its lining becomes highly glandular. This glandular portion of the vas deferens is coiled into a compact mass—the **epididymis** (*ep*). Beyond this its wall becomes thick and muscular (ductus ejaculatorius—*e.d*): it then is continued towards the middle line as a very narrow tube and opens into the swollen inner end (“prostate”) of a thick muscular tube—the penis—which can be pushed out through the male opening. This like the female opening is unpaired and in the mid-ventral line, the two openings being five annuli (= one somite) apart.

The eggs of the leech, fertilized in the vagina or uterus, are deposited in a cocoon, measuring about 25 mm. by 15 mm., secreted on the surface of the somites in the neighbourhood of the female opening, though this portion of the ectoderm is not so thickened as to form a conspicuous projecting clitellum as is the case in the earthworm. A thick outer spongy layer of the cocoon is said to be deposited secondarily by the action of the lips and to be formed possibly by the pharyngeal glands. The cocoon is deposited in damp earth near the water margin.

The nervous system of the leech is arranged on the same general plan as that of *Lumbricus*, the only important difference being that the ganglia at the two ends of the ventral nerve-cord are crowded together and fused. Thus the circum oesophageal commissures pass ventrally into a ganglionic mass representing the first five ganglia of the ventral

cord fused together, while at the hinder end a group of seven ganglia are similarly fused. Sensory cells are scattered through the epidermis; here and there these are clumped together in definite sensory papillae which are seen regularly arranged on the outer surface of the body and at the front end five pairs of these on the dorsal surface of the following annuli—1, 2, 3, 5, 8—are converted into eyes. These can be clearly seen as black spots if the front end of a pale-coloured specimen is held close to a lamp so that the light shines through it.

The Hirudinea as a group are annelids which have become specialized in adaptation to their bloodsucking semiparasitic habits. They are characterized by their suckers—the anterior one for fixing the lips round the incision which they make in the skin of their prey, the posterior for adhering. The development of the posterior sucker at the hinder end, where during the growth of an ordinary annelid new segments are added to the body, serves to bring this increase in the number of somites to an abrupt stop after a more or less definite number (not exceeding 34) has been reached.

The somites themselves have become far less distinct than they are in the other annelids—in external view owing to the absence of chaetae and parapodia and to the superficial subdivision of most of the somites into annuli, in internal structure owing to the spacious coelomic cavity with its division into distinct compartments having become converted into a continuous spongework. A characteristic difference in detail is that in the Leeches the original paired genital openings have been shifted into the middle line so as to become unpaired.

Included in the group Hirudinea are a number of different genera. One of these—*Acanthobdella*, found attached to fresh-water fishes in the great lakes of Northern Russia—is of great interest from the evolutionary point of view, being as it is a link which serves to connect up the Leeches with the other annelids, for it possesses on its first five somites perfectly typical chaetae and its coelome is still a spacious body-cavity divided up by about twenty incomplete transverse septa.

Amongst the Leeches more closely allied to the medicinal Leech (*Hirudo medicinalis*) are the genera *Aulostoma*, the Horse Leech, which commonly leaves the water to devour earthworms—its favourite food, *Haemadipsa*, the unpleasant Land Leech of the tropics, and *Nepheleis* one of our commonest small fresh-water Leeches, which feeds on worms and molluscs.

Another set of Leeches are characterized by the saws having disappeared and a protrusible proboscis having taken their place. Amongst these are *Pontobdella*—a large marine leech which attacks Skates and

Sharks, *Branchellion*, also usually a parasite of Elasmobranch fishes, which has developed branched gills along the side of its body, and *Clepsine* a common fresh-water leech which instead of surrounding its eggs with a cocoon carries them about attached to the ventral surface of the body and broods over them.

A point of practical importance to bear in mind about leeches is that being bloodsuckers they are liable to serve as the intermediate host for protozoan blood parasites: they have already been shown to act as such in the case of various trypanosomes of fresh and salt water fish.

The Polychaeta, Oligochaeta and Hirudinea are the three main subdivisions of the phylum ANNELIDA or segmented worms. The phylum is characterized by a well-marked assemblage of characters.

Chaetae are usually present—local exaggerations of the cuticle. The central nervous system is in the form of a ganglionated ventral cord connected with supra-oesophageal ganglia. A coelomic body-cavity is present, with paired nephridial tubes. The alimentary canal traverses the entire length of the body—mouth and anus being situated normally at its opposite ends.

The body is metamericly segmented, being divided into a series of homologous somites in which are repeated such organs as chaetae, coelomic compartment, nephridia, nerve-ganglion. And in correlation with forward determinate movement the front end of the body shows more or less marked differentiation to form a head in which is situated the mouth and in which are concentrated nerve-centres and sensory cells.

Finally in the case of those annelids which retain the ancestral marine habit there is commonly a free larval stage of the trochosphere type.

BOOK FOR FURTHER STUDY

I. GENERAL TEXT-BOOK

The Cambridge Natural History, Vol. II.

CHAPTER V

THE PARASITIC WORMS

IN this chapter we shall digress from the Coelomata to deal with three groups of worms—the Trematoda, the Cestoda and the Nematoda—the evolutionary relationships of which with the other groups of the animal kingdom are quite obscure but which are of special interest in view of their mode of life as parasites within the bodies of other animals.

TREMATODA

An excellent example of this important group of parasites is the Liver-fluke—*Fasciola* (or *Distoma*) *hepatica*—which inhabits the bile-ducts of the sheep and is the cause of “Liver Rot,” a source of considerable loss to sheep farmers in marshy, badly drained, districts.

A fully developed fluke (Fig. 74, H) is a flattened leaf-shaped creature about 30 mm. in length. It is covered by a distinct tough cuticle with innumerable backwardly projecting points so that any relative movement taking place between it and the surrounding tissue tends to make the fluke slip forwards. At the pointed anterior end is the small opening of the mouth, situated at the bottom of a muscular cup—the anterior or **oral sucker** (*o.s.*). A little way behind the posterior limit of the pointed front portion, and right in the middle line of one of the flat surfaces, is a second, larger, **ventral sucker** (*v.s.*) by which ordinarily the fluke adheres to the wall of the bile-duct in which it lives.

The mouth-opening leads into a flask-shaped muscular pharynx by which the blood on which the fluke feeds is sucked in and forced onwards into the intestine. This latter constitutes the remaining and by far the larger portion of the alimentary canal. The intestine has the form of a much elongated Π —the pharynx leading into the curved portion and the straight limbs running back parallel to one another towards the hind end of the body where they end blindly. Each limb gives off numerous

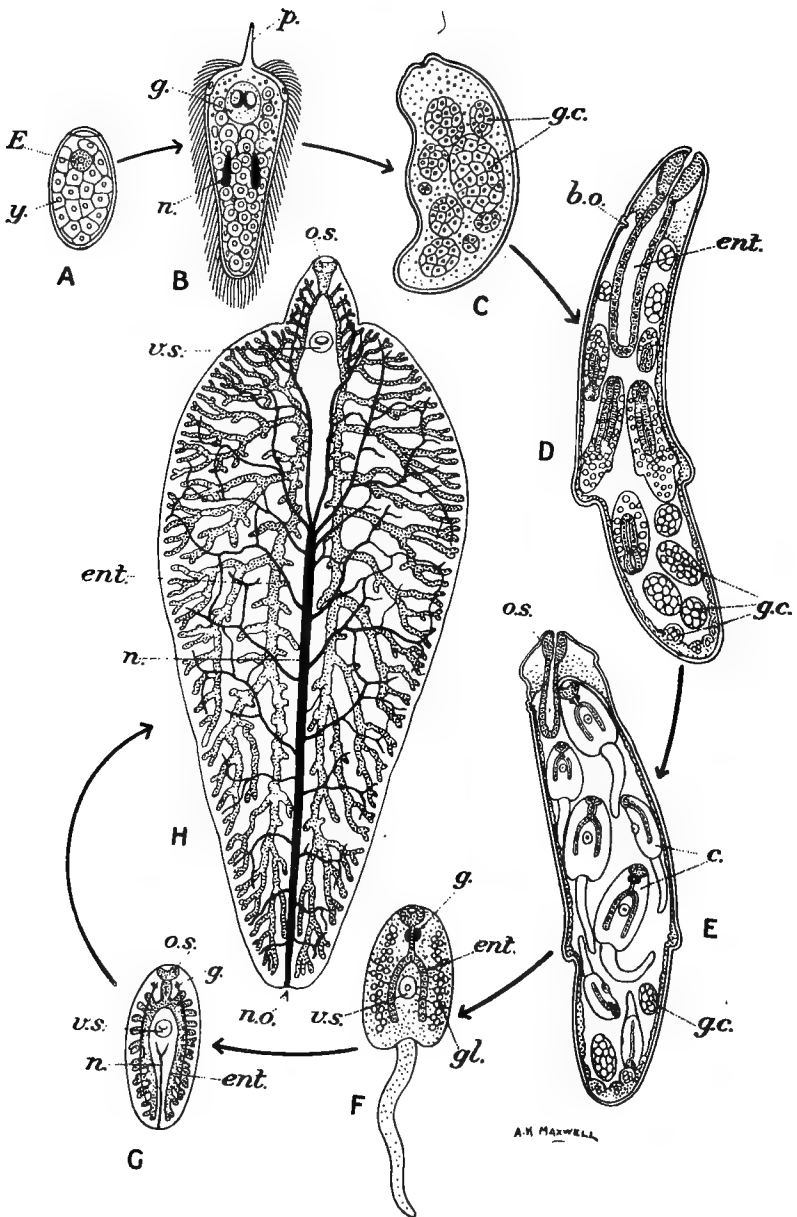

FIG. 74.

Life-history of *Fasciola hepatica*. A, "egg"; B, miracidium; C, sporocyst; D, E, rediae; F, cercaria; G, tail-less encysted stage; H, adult (neither reproductive organs nor nervous system are shown). *b.o.*, Reproductive opening of redia; *c.*, cercaria; *E*, egg; *ent.*, intestine; *g.*, nerve-ganglion; *g.c.*, germ-cells; *g.l.*, cyst-producing gland-cells; *n.*, nephridium (only a few of the main branches of the excretory network are shown); *n.o.*, nephridial opening; *o.s.*, oral sucker; *p.*, proboscis (extruded); *v.s.*, ventral sucker; *y.*, yolk-cells.

branches on its outer side and these, branching again, fill up a great part of each half of the body with blindly ending branches.

There is no trace of coelomic body-cavity, the interval between the alimentary canal and the body-wall being filled up with a cellular sponge-work (**parenchyma**), with fluid in its meshes. Connected with this is the excretory system,—very different from the corresponding system of the annelids. Running along the median axis of the body in its posterior two-thirds is a wide tube, the main excretory duct (Fig. 74, H, *n*). This opens to the exterior by a pore at the hinder edge of the fluke. Communicating with the main duct is a complicated network of fine excretory tubes which traverse the parenchyma in all directions. Hanging on to the tubes composing this network are numerous somewhat pear-shaped cells (cf. Fig. 75, A) which if examined in the live condition with a high power of the microscope attract attention by the curious flickering in their interior like that of a candle-flame. These are what are called **flame-cells**. Each consists of a tube in communication with the general excretory network. The free end of the tube is blocked up by a mass of soft protoplasm containing a nucleus, and bearing a tuft of large cilia or flagella which project from it down the cavity of the tube. It is the movement of these flagella that gives the characteristic flickering appearance. The waves of flexure passing down the flagella from base to tip tend to set up a negative pressure within the closed end of the tube which causes the watery fluid from the parenchyma meshwork to be drawn into the tube through the protoplasmic plug and then sent onwards through the tubular network to the exterior. The function of the flame-cells is to keep draining away the excess of fluid in the meshes of the parenchyma, and in some animals in which observation is easier than it is in the fluke it is possible to determine that the activity of the flame-cell is closely related to the pressure of fluid, for diminution of this pressure, for example by letting some of the fluid escape through a small puncture of the body-wall, causes instant cessation of the flagellar movement, which commences again as the pressure is re-established.

The nervous system as in all internal parasites is very simple—a collar with three ganglia round the anterior part of the alimentary canal sending back two long trunks towards the hind end of the body: and there are no special organs of sense.

The fluke is hermaphrodite and, as so often happens in such cases, the reproductive organs are exceedingly complicated (Fig. 76). They are also of great size, as is again very usual in parasites where there is as a rule enormous wastage through the great majority of young that are produced failing to reach a new host.

The ovary (Fig. 76, *o*) is a much branched organ, lying usually in the right (sometimes however the left) half of the body, about a quarter of the distance from front end to hind end. It is continued towards the mid-line of the body as a simple tube—the oviduct. While the ovary produces the functional macrogametes, there is present also a great mass

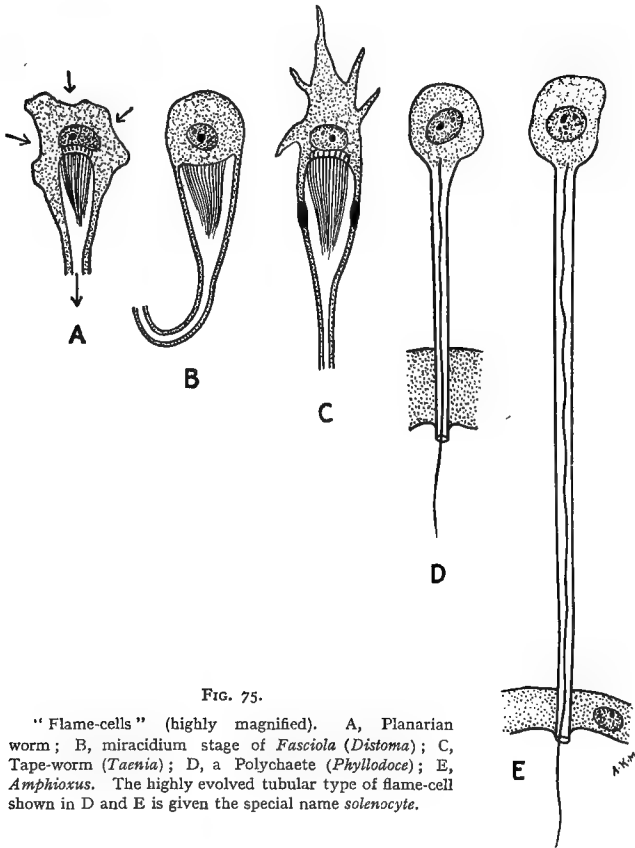

FIG. 75.

"Flame-cells" (highly magnified). A, Planarian worm; B, miracidium stage of *Fasciola* (*Distoma*); C, Tape-worm (*Taenia*); D, a Polychaete (*Phyllodoce*); E, *Amphioxus*. The highly evolved tubular type of flame-cell shown in D and E is given the special name *solenocyte*.

of female gonad which may be said to have degenerated, its cells being no longer functional macrogametes but being simply **yolk-cells** destined to provide the zygote with a supply of food material. This degenerate gonad is in the form of innumerable little spherical **yolk-glands** (*y.g.*), arranged in a broad band round the whole margin of the body except its extreme front end. In the fresh specimen this band is of a dark colour, the yolk being dark greenish, but when the fluke is kept in spirit

for some time this colouring matter is dissolved out. From each yolk-gland there passes a minute yolk-duct and these join together to form a main yolk-duct running along the zone of yolk-glands near its inner

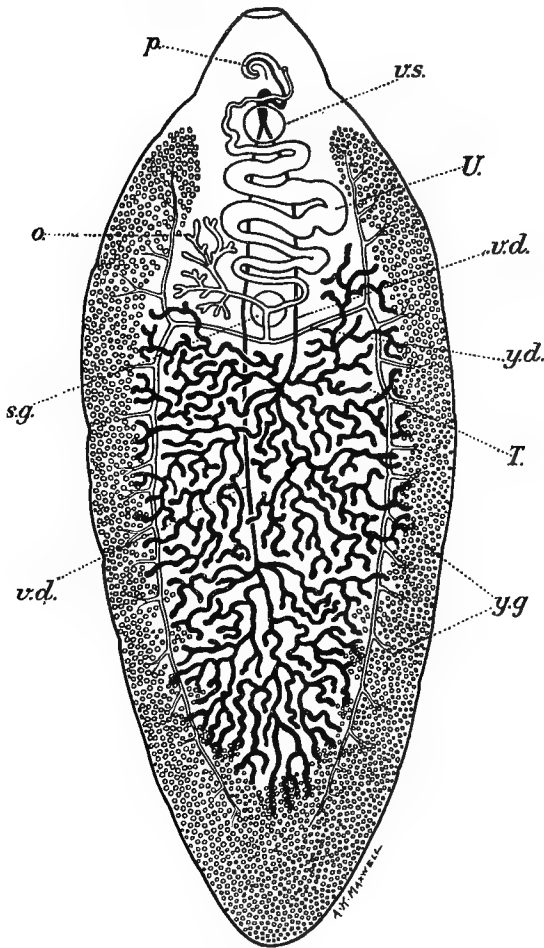

FIG. 76.

Fasciola hepatica—genital organs, seen from the ventral side. *o*, Ovary; *p*, penis; *v.s.*, ventral sucker; *s.g.*, shell-gland; *T*, testis; *U*, uterus; *v.d.*, vas deferens; *y.d.*, yolk-duct; *y.g.*, yolk-glands.

margin. Just about the level of the hinder end of the ovary a transverse yolk-duct (*y.d.*) starts off from the longitudinal duct, passes to the middle line, and is continued into its fellow. Where the two meet they are continued directly forwards as a short median yolk-duct which at its

front end joins the oviduct. At the point of junction the macrogametes from the ovary meet the yolk-cells from the yolk-glands and they come together into little packets, one gamete to a number of yolk-cells, each enclosed in a horny-looking egg-shell ellipsoidal in shape and with a detachable lid at one end (Fig. 74, *A*). The substance of the egg-shell is generally believed to be secreted by the **shell-gland** (Fig. 76, *s.g.*), a spherical body with fuzzy surface which surrounds the point of junction of yolk-duct and oviduct.

From the shell-gland the female duct is continued onwards as a wide winding tube, the **uterus** (*U*), most of which is usually filled with eggs. Towards its termination it becomes much narrowed and it opens to the exterior at a point not quite half-way from the ventral sucker to the mouth.

The male organs are much less complicated than the female. The testes (*T*), two in number, are greatly branched organs lying one in front of the other, in the region of the body bounded in front by the transverse yolk-duct and externally by the zone of yolk-glands. From each testis there passes forwards a slender tube—the vas deferens (*v.d.*), that of the anterior testis lying on the left side. The two vasa deferentia unite in the neighbourhood of the ventral sucker and form the expanded seminal vesicle and this is continued onwards as a very fine tube, the ejaculatory duct, which opens to the exterior close to the female opening. The terminal part of the ejaculatory duct has thick muscular walls and can be pushed out at the external opening forming the penis (*p*).

The Liver-fluke has a very complicated and interesting life-history (Fig. 74). The fertilized eggs (*A*) are laid within the bile-ducts, down which they pass and eventually, after it may be accumulating for a time in the gall-bladder, reach the intestine and so the exterior. Should the egg fall on dry ground no further development takes place, but if it fall into water there hatches out from it in the course of a few weeks—the exact period varying with the temperature, being shorter in summer and being prolonged by cold wintry weather—a larva of a characteristic kind known as a **miracidium** (Fig. 74, *B*). The miracidium is a small creature (about $\cdot 12$ mm. in length) looking to the naked eye as it swims about not unlike a Paramecium. When examined under the microscope it is seen to be in outline somewhat like the adult fluke. Its body is covered with powerful cilia except just at the front end where there is a conical **proboscis** (Fig. 74, *B*, *p*) which can be retracted and thrust out. A little way behind the proboscis is a distinct nerve-ganglion (*g*) and embedded in this a characteristic α -shaped eye. Further back in the body there

is present on each side a flame-cell (Figs. 74, B, *n*; and 75, B). Conspicuous amongst the parenchyma which fills the interior are numerous reproductive cells—the **germ-cells**.

The miracidium swims actively hither and thither but normally dies after a short life of about eight hours unless it comes across a small water-snail of a species (*Limnaea truncatula*) common in marshy districts. The miracidium is able to detect the presence of a snail in its neighbourhood and is indeed able to follow up its track on the mud. It approaches the snail and attaches itself to its soft skin by its proboscis, a *Limnaea* which has been attacked by many miracidia being given a furry appearance through the miracidia hanging on to it by their probosces. In such a case the snail may be killed, but more usually it is attacked only by one or a few miracidia and does not suffer serious damage. The miracidium after attaching itself bores through the skin of the snail, makes its way into the body-cavity and eventually takes up its position in the large blood spaces in the roof of the lung. Here it loses its shape, the nerve-ganglion and eye degenerate and it becomes a mere bag (**sporocyst**—Fig. 74, C) containing the germ-cells. The latter undergo repeated division, giving rise to large masses (*g.c*) at first rounded in form but gradually becoming elongated. Each of these gradually takes on the form of the next stage of the life-history, known as the **redia** (Fig. 74, D)—a worm-like creature with two short stumps projecting from its body one on each side towards its hinder end. At the front end is the mouth which leads through a muscular pharynx into a short simple blindly-ending intestine (*ent*). The interior of the body is filled as before with parenchyma containing scattered masses of germ-cells (*g.c*) and near the head end is a single reproductive opening (*b.o*). The rediae when fully formed make their way out of the remains of the sporocyst and wander through the tissues of the snail where they are found especially in the liver. The germ-cells within the rediae commonly develop into a new generation of rediae, but the germ-cells of this second generation develop not into rediae but into a type of larva known as a **cercaria** (Fig. 74, E, *c*, and F). The cercaria is a somewhat tadpole-shaped creature with an ellipsoidal body and a tail, by the flapping movement of which the cercaria is able to swim. There is a mouth at the front end, surrounded by a sucker and leading into a pharynx which opens into the intestine of characteristic \cap -shape (Fig. 74, F, *ent*). A ganglionic nerve-ring (*g*) surrounds the alimentary canal in the region of the pharynx. Towards each side of the body is a mass of gland-cells (*gl*). The space between these organs is filled with parenchyma. Finally about the middle of the body is a second sucker—the

ventral sucker (*v.s.*). If we ignore the tail it is clear that the structure of the cercaria is merely that of the adult fluke in a comparatively simple and undeveloped condition. The cercariae, whether produced from the first generation of rediae as they sometimes are or from a later generation as they more usually are, make their way out of the body of the parent redia and finally out of the snail, swimming away with a characteristic jerky motion.

Presently they drop off their tails and creep about in leech-like fashion by means of their suckers, shooting out the body to a considerable length and then shortening it. Under normal circumstances the cercaria creeps up on to a blade of grass and adhering to this by its ventral sucker proceeds to encyst, surrounding itself with a clear secretion produced by the conspicuous gland on each side of its body.

Within the cyst the cercaria goes on slowly developing, the features of the adult fluke becoming more and more distinctly recognizable (Fig. 74, G), but the development is not completed unless the blade of grass with its adherent cyst is cropped by a sheep. In this event the cyst is digested and the young fluke set free in the sheep's alimentary canal: it wanders up into the bile-duct and there in due course attains to its adult form and sexual maturity.

The TREMATODA are essentially parasites, and the group is characterized by the following combination of structural features—the unsegmented body with usually at least a ventral sucker for attachment to the host, the thick cuticle, the forked blindly-ending intestine, and the hermaphrodite reproductive organs.

The group is divided into two sub-groups, the Monogenea and the Digenea.

The DIGENEA, or digenetic Trematodes, are given this name from the fact that the parasitic portion of their life-history is divided between two distinct host-animals as is the case with *Fasciola*—the sexual phase inhabiting usually the alimentary canal of a Vertebrate, while the asexual generations (rediae, cercariae) infest Molluscs. In some cases a second Vertebrate host may be introduced into the life-cycle, the cercaria making its way into the body of a fresh-water fish and there encysting.

There exist a great variety of Trematodes in the group Digenea, inhabiting various Mammalian hosts, and many of these are liable, as is the case with *Fasciola hepatica*, to find their way occasionally into the bodies of human beings. A few are normal and dangerous parasites of man.

SCHISTOSOMA (BILHARZIA)

One of the most important parasites of man is a small distomid named *Schistosoma* (or *Bilharzia*) which lives in the veins of the body and produces serious disease, the symptoms differing according to the particular region of the body affected. The most conspicuous peculiarity of the genus *Schistosoma* as compared with *Fasciola* is that the flattened body has its edges curved towards the ventral side so as to take the form of a cylinder, the wall of which is interrupted ventrally by a longitudinal slit bounded by the edges of the body. The two sexes are strikingly different in appearance (**sexual dimorphism**) the female being longer and of much smaller diameter. When sexually mature the female apparently lives permanently in contact with the male, gripped firmly between the incurved edges of the latter's body (Fig. 77, A). The adult worms live in the venous blood-stream and are often particularly conspicuous in the branches of the hepatic portal vein which run in the mesentery.

Our knowledge of the life-history of *Schistosoma* has been greatly extended by the researches of Leiper carried out during the period of the Great War and prompted by the dangers involved in the presence of large masses of European troops in *Schistosoma*-infected regions such as Egypt. We are now able to trace the life-history in its main outlines and this will here be done in the case of *Schistosoma haematobium*.

The eggs are deposited in the blood-stream, especially in the small veins of the bladder. The egg (Fig. 77, B, 1) is somewhat ellipsoidal in form, about 80μ in length, and the shell is prolonged at one end into a sharp pointed spine. No further development takes place unless it reaches the exterior, and this it does normally by being passed from the small blood-vessels of the bladder-wall into the cavity of that organ—the sharp spine perforating the vessel wall and the egg probably being forced out by the muscular contraction of the bladder-wall during the final stages of the bladder being emptied. The urine in the bladder thus comes to contain eggs along with a certain amount of blood, the latter affording a conspicuous symptom (haematuria) of the disease.

Further development of the egg is dependent upon its reaching fresh water. After a variable period there hatches out a ciliated miracidium (Fig. 77, C), elongated in form, possessing at its front end a solid vestige of alimentary canal (*a.c.*), and on each side of this a large gland-cell (*g.*). Near the centre of the body is a nerve-ganglion (*n.g.*) and on each side a tortuous slender nephridial tube with two flame-cells (*n.*).

The miracidium may live for a few hours but is incapable of

continuing its life-history unless it encounters a water-snail—usually one of the various species of *Isidora* (= *Bulinus*). In the liver of the snail the *Schistosoma* takes the form of a long more or less tubular sporocyst, and the germ-cells in the interior of this, which were already

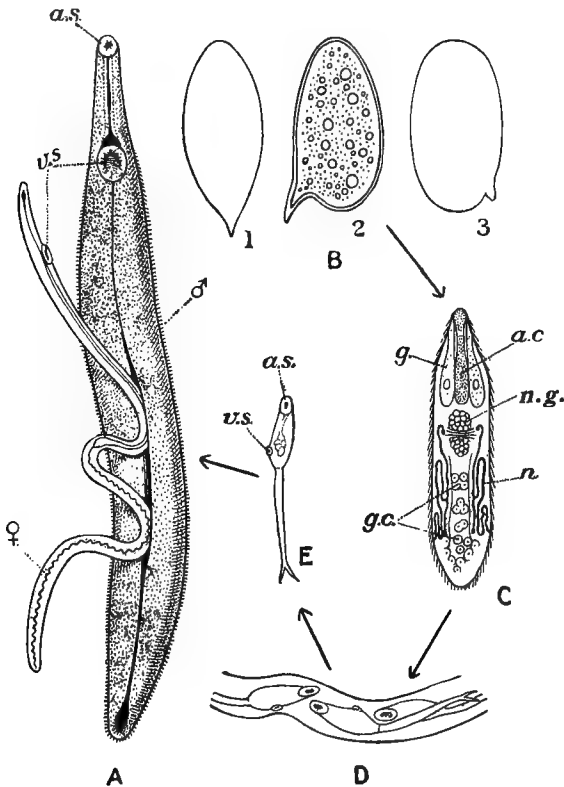

FIG. 77.

Schistosoma. A, Ventral view of adult male with the female in position between the infolded edges of its body; B, eggs of (1) *S. haematobium*, (2) *S. mansoni* and (3) *S. japonicum*; C, miracidium; D, sporocyst; E, cercaria. B and C are more highly magnified than the other stages. a.c., Alimentary canal (vestigial); a.s., anterior sucker; g, gland-cell; g.c., germ-cells; n, nephridium; n.g., nerve-ganglion; v.s., ventral sucker.

recognizable in the miracidium stage (Fig. 77, C, g.c.), develop into cercariae (Fig. 77, D and E) with forked tails.

These cercariae are not capable of remaining alive in the free state for more than about 40 hours, but if within this period they come in contact with the warm skin of a mammalian host they cast off their tails

and burrow through the skin into a lymphatic or blood-vessel. They are carried round in the blood-stream and normally settle down for a time in the liver, whence as sexual maturity approaches they migrate to their definitive home, e.g. the veins of the mesentery.

S. haematobium while best known in connexion with Egypt—where in places as many as 90 per cent of the population are infected—occurs also all over the continent of Africa where conditions are favourable and extends into Asia at least as far as Persia. It has apparently been introduced into Australia, and as a result of the Great War there will doubtless take place a wide extension of its distribution in parts of the world where suitable climatic conditions are combined with the presence of water-snails capable of acting as hosts to the sporocyst stage. When once established in a particular district it will be difficult to get rid of owing to small mammals such as rats and mice being able to play the part of warm-blooded host. Freedom from infection in such a district can only be assured by taking precautions against infected water coming in contact with the skin. Even getting the feet wet by walking through swampy ground may communicate infection as the cercariae are able to penetrate wet stockings. If water containing cercariae is taken into the mouth they are liable to penetrate the lining of the mouth and so reach the blood: those actually swallowed are in all probability killed by the digestive juices of the alimentary canal. Water used for drinking or washing should be freed from cercariae by the use of an efficient filter, by boiling, by the use of a chemical disinfectant such as sodium bisulphate (·1 %), or by keeping the water stored for 48 hours before use so as to allow any cercariae to die off. In the case of stationary camps and settlements the last-mentioned method of sterilizing the water so far as *Schistosoma* is concerned is obviously the simplest and most practical.

S. mansoni occurs also in Egypt and other parts of Africa, as well as in Tropical America and the West Indies. While agreeing in its general features with *S. haematobium* it differs in certain details. The sharp spine is situated not at the end of the egg-shell but at one side (Fig. 77, B, 2), and the eggs are usually set free not in the bladder but in the intestine, causing dysentery-like symptoms.

The sporocyst stage is found not in *Isidora* but in the flattened disc-shaped water-snails of the genus *Planorbis*.

S. japonicum occurs in China, Japan and the Philippines. The eggs are—as is the case also with the adult—rather smaller than those of the

other species, and the spine which is small and inconspicuous is lateral in position (Fig. 77, B, 3, and Fig. 90, D). The eggs reach the exterior by way of the intestine as in *S. mansoni* and the sporocyst stage is passed in a water-snail *Hypsobia* (= *Katayama*) with a long pointed conical shell.

As regards other flukes parasitic in man note should be taken of three, normally inhabitants of Eastern Asia but liable to be carried to other parts of the world by immigrants.

CLONORCHIS

Slender-shaped Liver-flukes which are placed in this genus are frequent parasites in China and Japan and cause serious damage to the liver. They reach a length of from 6 mm. to 20 mm. The fresh-water snail into which the miracidium bores is apparently a *Melania* and the cercariae find their way into the bodies of various fresh-water fish where they remain encysted amongst the connective tissue and muscle until swallowed by the mammalian host. The latter is commonly a man, dog, cat or pig.

PARAGONIMUS

A common and destructive parasite of man (as of dogs and cats) in China, Korea and Japan, this fluke may occur in various organs of the body but its favourite haunt is the lung, in which as it grows in size it forms large cavities. It measures up to about 12 mm. in length and is thick-bodied, nearly circular in cross section. The eggs pass away in the sputum to which they give a characteristic brown colour. The life-history is of the normal type, the incriminated water-snail being a *Melania*, except that as in *Clonorchis* the cercaria enters an intermediate host before encysting. Normally this appears to be a fresh-water crab, but as these are not commonly used as food by man in districts where the parasite is common the suspicion is entertained that some other animal, possibly a fresh-water fish, may take the place of the crab.

FASCIOLOPSIS

This parasite, which inhabits the intestine of the pig and of man in Eastern Asia—from India to China and the Malay Archipelago—is mainly of interest from its being the largest fluke known to occur in man, reaching a length sometimes of 75 mm. Its life-history is uncertain.

CESTODA

The Cestoda or Tape-worms are like the Trematodes essentially a group of parasites but they are marked off from the Trematodes by very distinctive features, particularly by the elongated tape-like form of the body with suckers or other organs of adhesion at the "head" end, by the absence of an alimentary canal, and by the fact that the body becomes subdivided into successive pieces known as **proglottides** which recall the chain of sexual individuals of such a Polychaete as *Myrianiida*, each proglottis possessing in itself a complete set of reproductive organs. Further there is present a characteristic larval phase in the life-history known as the **cysticercus** or Bladder-worm which inhabits a different host from that inhabited by the adult.

TAENIA

A typical Tape-worm of the genus *Taenia* (Fig. 78) possesses the following features. The body is greatly elongated and flattened except towards the "head" end, and it is divisible into two regions—a short **scolex** (Fig. 78 A, *S*) with a rounded "head" by which the worm hangs on to the lining of the intestine of the host animal, and a flattened main portion formed of a chain of usually numerous—it may be hundreds—of proglottides. The tip of the scolex is formed by a more or less pronounced conical portion, the **rostellum** (Fig. 78, B and C, *r*), which at its base widens out into the "head." At the periphery of the "head" are four large rounded muscular **suckers** (Fig. 78, B and C, *s*) while arranged in a circle round the base of the rostellum are numerous recurved **hooks** (*h*). The shape and arrangement of these hooks show characteristic differences in different species.

The surface of the body is covered by a well-developed but permeable cuticle through which the tape-worm absorbs nourishment from the digested food-material of its host amongst which it lives. Remaining as it does alive and healthy amongst the digesting food of its host the tape-worm naturally remains quite unaffected by the digestive ferments which bathe its surface. The internal organs are surrounded by a packing of **parenchyma**, through which are scattered numerous small rounded **calcareous bodies**. There is no trace of coelomic body-cavity, or of alimentary canal, or of blood system.

The nephridial organs are of the same type as those of the Trematoda, a network of fine tubular channels traversing the parenchyma and bearing scattered flame-cells. This excretory network drains into a

main longitudinal excretory tube which runs along each side of the body, passing uninterruptedly through the chain of proglottides. The two tubes are connected in ladder-like fashion close to the hinder limit of each proglottis and in the last proglottis of the chain the transverse connecting channel opens to the exterior.

The nervous system consists of numerous sensory cells connected with a network or plexus of nerve fibres lying just below the epidermis, this network being connected in turn with a series of longitudinal trunks

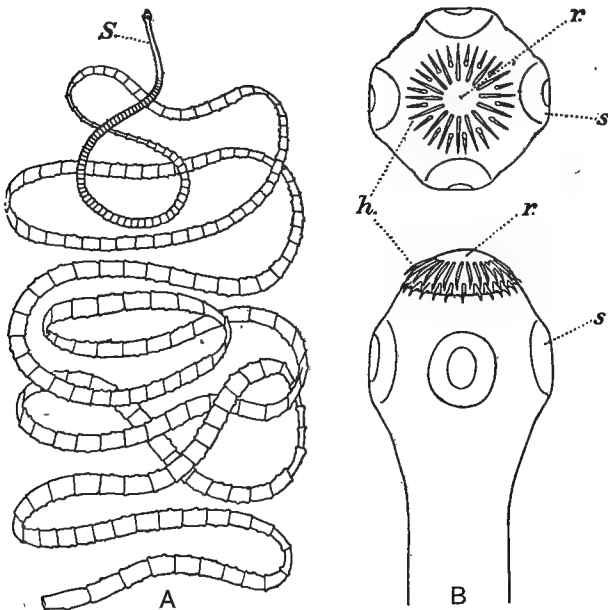

FIG. 78.

Taenia serrata. A, Complete tape-worm; B, scolex in side view; C, scolex, end view. *h*, Hooks; *r*, rostellum; *S*, scolex; *s*, sucker.

lying at a deeper level. Of these longitudinal trunks there are ten, two of which, situated laterally, just external to the main excretory duct, are larger than the others. The longitudinal trunks are connected by numerous irregular commissures of which there is a specially complicated arrangement in the "head" region.

The reproductive organs are hermaphrodite and of much complexity. The male gonad consists of numerous small spherical testes (Fig. 79, A, *t*) scattered throughout the parenchyma, each having a slender tubular vas efferens connected with it. The vasa efferentia become joined to-

gether into larger and larger channels, terminating eventually at the inner end of a main transversely-running vas deferens (*v.d.*), which functions as a seminal vesicle for storing the spermatozoa and opens into a crater-like recess, common to it and the female opening, and situated at the apex of a small projection, or papilla, at the margin of the proglottis. In successive proglottides the genital papillae are quite irregularly on one side or the other. As in the case of the fluke the terminal portion of the male duct is muscular and can be protruded.

The female portion of the gonad consists (1) of an ovary (Fig. 79, A, *o*) of a somewhat dumb-bell shape, arranged transversely across the

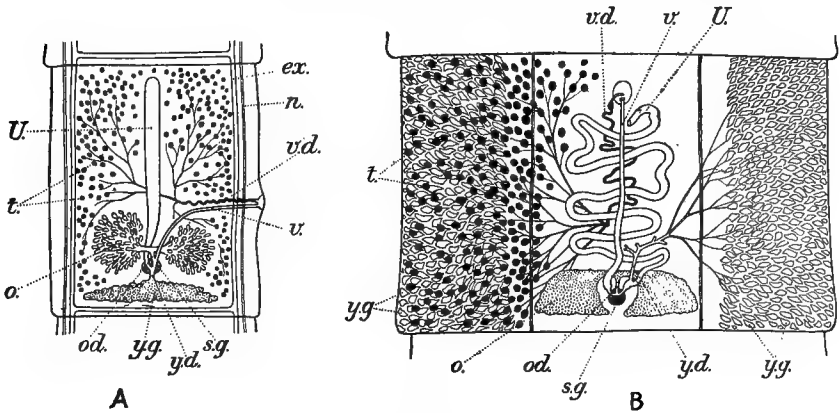

FIG. 79.

Illustrating the arrangement of the genital organs in a sexually mature proglottis of A, *Taenia* and B, *Bothriocephalus*. *ex.*, excretory canal; *n.*, nerve-cord; *o.*, ovary; *od.*, oviduct; *s.g.*, shell-gland; *t.*, testes; *U*, uterus; *v.*, vagina; *v.d.*, vas deferens; *y.d.*, yolk-duct; *y.g.*, yolk-glands. (In B for the sake of clearness the testes are omitted in the right half of the figure and the yolk-ducts in the left half.)

proglottis in its posterior half, the swollen ends projecting into numerous little tags, and (2) a lobed yolk-gland (*y.g.*), also situated transversely but nearer to the posterior boundary of the proglottis. From the middle of the ovary there slants backwards the oviduct (*od.*) which joins the yolk-duct. From the latter in turn there passes forwards, along the middle line of the proglottis, a long blindly-ending pocket, the uterus (*U*). Surrounding the junction of uterus and yolk-duct is a rounded shell-gland (*s.g.*). The main female duct, formed by the union of yolk-duct and oviduct, slants forwards and eventually runs transversely, parallel to the seminal vesicle, towards the external opening as the vagina (*v.*).

Microgametes received in the vagina unite with the macrogametes coming from the ovary by way of the oviduct and the resulting zygotes, with yolk-cells from the yolk-duct, become encased in shells by the activity of the shell-gland and then pass forwards into the uterus in which they accumulate. The accumulation of eggs brings about changes in the appearance of the uterus which are very characteristic. Its side walls become gradually distended to form pockets which gradually increase in length, becoming irregularly branched as they do so, until they almost reach the lateral boundary of the proglottis. Eventually the greater part of the whole proglottis is occupied by the branches of the uterus (Fig. 80, A and B), the other reproductive organs shrivelling up and becoming quite inconspicuous.

This condition, in which the proglottis is little more than a packet of zygotes or fertilized eggs, is found in the hindmost proglottides in the chain, i.e. the oldest proglottides, for the proglottides originate, just as do the sexual individuals of *Myrianida*, by being cut off from the hinder end of the asexual portion or scolex. Eventually the old proglottis, full of eggs, is dropped off. It passes to the exterior with the faeces of the host : it may show signs of life for some time but before long it dies and disintegrates and the eggs are scattered abroad, nothing more happening unless the egg is swallowed by the appropriate host animal.

CESTODE LIFE-HISTORIES

Taenia serrata, one of the commonest tape-worms of the dog, affords an excellent example of the typical cestode life-history. The further development of the egg takes place if, and only if, it be swallowed by a rabbit. In this event there hatches out within the alimentary canal a small rounded larva, provided with six sharp blades by means of which it cuts its way into the wall of the alimentary canal. Eventually it reaches the blood and is carried off in the blood-stream towards the liver. It apparently usually leaves the blood-vessel within that organ and then may migrate for some distance before it finds a suitable spot, such as the lining of the body-cavity, in which to settle down.

It now grows into the cysticercus or bladder-worm—a semi-transparent lemon-shaped vesicle about the size of a pea and full of clear fluid. Through the wall of the vesicle can be seen shimmering an elongated whitish body which projects inwards from one pole. In a well-infected rabbit many of these bladder-worms may be seen scattered about in the lining of the body-cavity. If a fresh bladder-worm be slightly squeezed between the fingers the whitish structure within it shoots out, and it

is now seen to be a typical scolex, with suckers and hooks, which had been inverted into the interior of the cysticercus.

If a live bladder-worm is swallowed by a dog the scolex becomes everted within its alimentary canal and attaches itself to the lining by means of its hooks and suckers. The vesicle is digested off and the scolex proceeds to grow in length and bud off the chain of proglottides so that it assumes the characters of the typical tape-worm.

Taenia caninum, another common tape-worm of the dog and also of the cat, is often separated from *Taenia* as a distinct genus *Dipylidium* owing to conspicuous differences. Each proglottis has not the typical rectangular form but rather approaches the elliptical—the lateral boundaries bulging outwards. Further, each proglottis contains a double set of reproductive organs, each with its own openings situated in a little notch which is conspicuous in the middle of each lateral edge. In this case the cysticercus is of very minute size and is often termed a cysticercoid. The minute size is correlated with the fact that this phase of the life-history is passed in the body of a dog-louse (*Trichodectes*) or flea (*Pulex*). Its occasional occurrence in the human flea is perhaps responsible for the fact that this tape-worm occurs occasionally, though rarely, in the human being.

Taenia coenurus is a tape-worm which occurs not uncommonly in Sheep-dogs. The bladder-worm stage is remarkable for its great size (up to 2 inches, or even more, in diameter) and for the fact that it produces from its lining not a single scolex but very many scolices which are visible as distinct little white grains through the translucent wall. This bladder-worm occurs in the sheep and a favourite situation for it is the brain where it produces the disease known as sturdy or staggers.

Among the Cestodes commonly occurring in Man there are four species with which the student should make himself familiar.

Of these the commonest in Britain and America and other beef-eating countries is *T. saginata* (Fig. 80, B), a tape-worm which quite usually reaches a length of thirty feet and sometimes much more. A peculiarity of this species is that the scolex is without hooks, while on the other hand the suckers are unusually large and powerful. The shed proglottides—which are what the medical man is most likely to come across—are readily differentiated from those of the next species by the number (20-35 on each side) and slenderness of the branches of the uterus.

The cysticercus stage (*C. bovis*) occurs amongst the muscles of the ox ("measly" beef).

Taenia solium (Fig. 80, A) is a common tape-worm of pork-eating countries. It measures from six to nine feet in length, has well-developed hooks, and its uterus in the old proglottis possesses on each side only relatively few (seven to ten) and relatively stout branches. The ovary

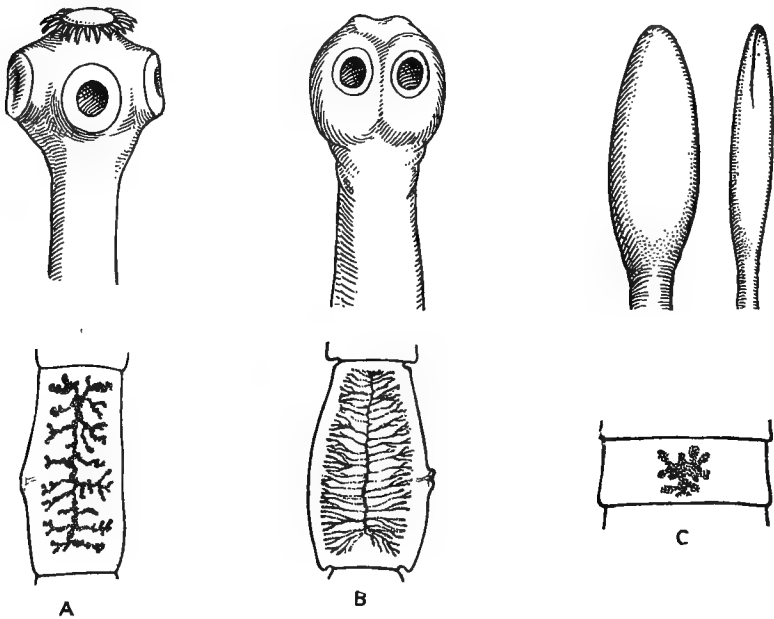

FIG. 80.

Three important human tape-worms (A, *Taenia solium*; B, *T. saginata*; C, *Bothriocephalus*): illustrating the more conspicuous distinguishing features of the scolex (upper row of figures) and of the old proglottis (lower row).

in addition to the main lobe at each end possesses a small branch near the middle.

The bladder-worm (*Cysticercus cellulosae*) occurs normally amongst the muscles of the pig but has been found in various other animals—dog, cat, rat, even in man himself.

Taenia echinococcus occurs not uncommonly in the dog in various parts of the world. It is more frequent than elsewhere in Iceland, Australia, and the stock-raising portions of South America. Its most

striking feature is its very small, almost microscopic, size—the whole worm, which consists of a scolex and 3 or 4 proglottides, measuring only about 2.5 to 6 mm. in length. In correlation with this minute size the tape-worm usually occurs in the dog's intestine not singly or, only as a few individuals but in enormous numbers together. The bladder-worm phase of the life-history occurs in various animals, especially ox, sheep, and pig and occasionally in man. Whereas the tape-worm stage is extraordinarily small, the bladder-worm on the other hand is relatively enormous, reaching sometimes a diameter of 7 inches. As in the case of *T. coenurus*, the wall of the bladder-worm produces not one merely but a large number of scolices, and in this case pocket-like ingrowths of the wall are formed which become separated off, drop into the cavity as secondary bladders, and go on actively producing crops of scolices. Ordinarily the surrounding tissues of the host endeavour to protect themselves by enclosing the bladder-worm in tough connective tissue, the whole forming one variety of what the surgeon terms **hydatid cysts**—easily identified as a rule when large by drawing off the contained fluid and searching it for hooks or complete scolices.

The bladder-worm of *Taenia echinococcus* is a very dangerous parasite, both from the large size to which it may grow within some important organ such as the liver, and also owing to the small size of the proglottis which renders it liable to be swallowed complete with its numerous contained eggs, each of which may develop into a bladder-worm.

Fortunately it is not common in most localities. Where a dog is infected the shed proglottides or their disintegrated remains are liable to get mixed up with the fur; thence they get on to the animal's tongue and are then ready to be deposited, when the animal licks a plate or a hand, in a position from which they may readily be transferred to the mouth of a human being.

BOTHRIOCEPHALUS

B. latus (Fig. 80, C) is again one of the large tape-worms—reaching a length of thirty feet. The genus *Bothriocephalus* is readily distinguished from *Taenia* by the fact that the "head" is somewhat lance-shaped, is without hooks, and possesses only two suckers, each in the form of a longitudinal slit along the side of the head. The mature proglottides are much broader in proportion to their length than in *Taenia*, and the reproductive openings are situated not on one side of the proglottis but in the mid line of its flat surface. The small bladder-worm occurs amongst the muscles of various fresh-water fish,

more especially the burbot (*Lota*) and perch (*Perca*). Consequently it occurs as a parasite of man in regions where fresh-water fish form a staple article of diet.

Tape-worms live in the intestine of the host amongst the digesting food and they nourish themselves by absorbing the products of digestion but although they reach a relatively large size it is difficult to believe that the amount of food which they purloin from the host can in itself be of any appreciable importance. Where actual pathological effects are produced by them, as in the case of the severe anaemia sometimes produced by *Bothriocephalus latus*, this would appear to be due to the metabolism of the tape-worm producing a toxin which is absorbed into the blood of the host.

The mode of infection by the various species of Cestoda will have become clear from their life-histories. In general it may be said that infection with the larval (bladder-worm) stage is brought about by swallowing the egg, while infection with the adult (tape-worm) stage is brought about by swallowing the scolex contained in the bladder-worm. Consequently the precautions to be taken against infection are in the case of the first mentioned such as are dictated by ordinary cleanliness, in particular the prevention of possibly infected animals from licking the skin or dishes used for food, and in the case of the second care that fish or meat is sufficiently cooked to destroy any larval cestodes that may be present in it.

NEMATODA

An excellent example of the nematode worms is afforded by the genus *Ascaris* which is a common parasite in the intestine of the horse and pig.

ASCARIS

The adult *Ascaris* (Fig. 81) is a cylindrical worm tapering towards its two ends and measuring in the female of *A. megalocéphala*, the species found in the horse, as much as 390 mm. in length: the male is smaller, about 180-200 mm. Apart from its smaller size the male is easily distinguished by the tail end of the body being curled in a ventral direction. The surface of the body is covered with a smooth cuticle; the skin is devoid of pigment; the body shows no trace of division into somites, and there are no parapodia or other conspicuous projections.

The body-wall of the *Ascaris* when examined in microscopic sections is found to possess many interesting features (Fig. 82). The cuticle (*c*)

covering the surface is very thick, and it is underlaid by the epidermis or ectoderm (*ep*) which is in the form of a syncytium or plasmodium, a continuous sheet of protoplasm containing scattered nuclei. At four points in the transverse section—in the dorsal line (*d.l.*), the ventral line (*v.l.*) and the two lateral lines (*l.l.*)—the epidermis is seen to be greatly thickened, so as to traverse the whole thickness of the body-wall. Of these thickenings of epidermis the dorsal and ventral are comparatively narrow, while the two lateral are broad. In the latter towards their inner end a round opening can be seen (*ex*) which is the cavity of the excretory tube cut in transverse section. This is a very remarkable organ, quite unlike the nephridium of the annelid. It forms a straight tube consisting of a greatly elongated single cell, hollowed out into tubular form, and traversing nearly the whole length of the body. At its hinder end the tube ends blindly, while in front it unites with its fellow to open by a minute pore in the mid-ventral line near the front end of the body (Fig. 81, *n*).

Also connected with the epidermis is the nervous system of the *Ascaris* which is of a comparatively simple character. Anteriorly a nervous ring encircles the alimentary canal and from this there pass back six longitudinal nerve strands embedded in the epidermis. Two of these lie in the substance of the dorsal and ventral line respectively while two others lie on each side, just dorsal and just ventral to the outer end of the lateral line.

As in parasites generally, there are no eyes or otocysts or other highly developed organs of sense.

The space between the inwardly projecting shelves of protoplasm forming the dorsal, ventral, and lateral lines is occupied by the muscular system (Fig. 82, *m.e*)—of special interest in the Nematoda from its consisting of a single layer of large myo-epithelial cells. Each of these cells is widest towards its inner end where it bulges into the body-cavity, and is narrower towards its outer end where it fits in amongst its neighbours. The surface layer of protoplasm in the outer portion of the cell is modified to form the specially contractile substance. The inner end of the cell tapers off into a protoplasmic tail (*t*), which may

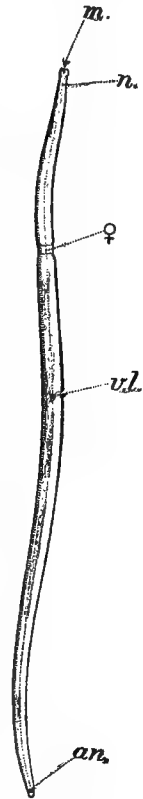

FIG. 81.

Female *Ascaris* as seen from the ventral side. *an.*, Anus; *m.*, mouth; *n.*, excretory opening; *v.l.*, ventral line; ♀, genital opening.

be looked on as a very primitive kind of nerve, as it passes straight to the dorsal or ventral line and forms a direct bridge connecting the longitudinal nerve trunk with the myo-epithelial cell.

Traversing the axis of the body is the alimentary canal which is very simple in structure in correlation with the fact that the *Ascaris* lives amongst food-material which is digested for it by its host. The mouth

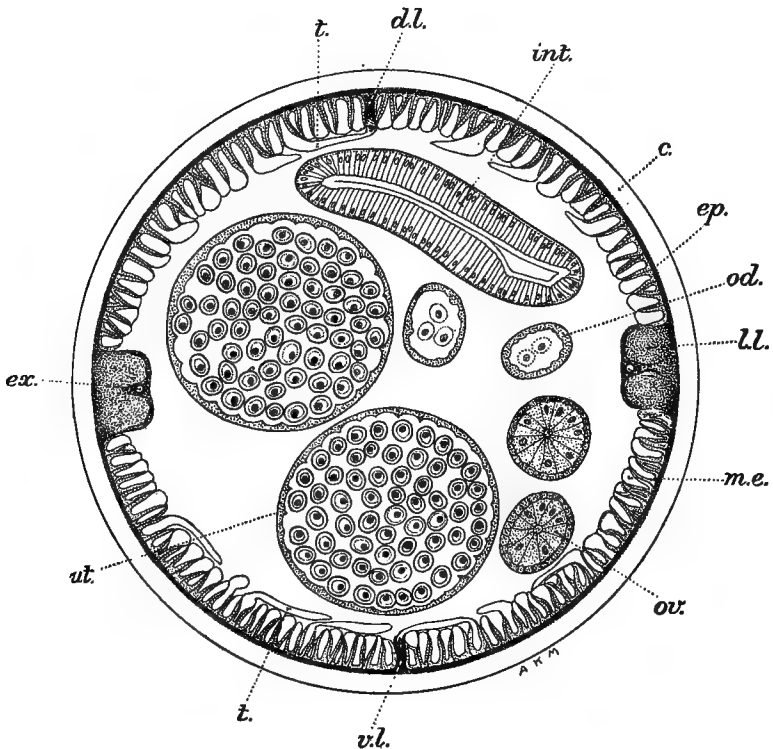

FIG. 82.

Ascaris (♀), transverse section. *c*, Cuticle; *d.l.*, dorsal line; *ep.*, epidermis; *ex.*, excretory tube; *int.*, intestine; *ll.*, lateral line; *m.e.*, myo-epithelial cell; *od.*, oviduct; *ov.*, ovary; *t.*, tail of myo-epithelial cell; *ut.*, uterus; *v.l.*, ventral line.

(Fig. 81, *m*) is a small pore at the tip of the body, surrounded by three roundish lobes arranged like a trefoil, one lobe being dorsal and the other two ventral. The mouth leads into a short pharynx with thick walls and this in turn leads into the thin-walled intestine which passes without a break to the anus—a transverse slit on the ventral side close to the posterior end of the body (Fig. 81, *an*). The wall of the intestine (Fig. 82, *int*)

consists of a simple layer of tall epithelial cells, bounded both externally and internally by a distinct cuticle-like membrane.

There is no layer of coelomic epithelium covering the surface of the alimentary canal and it is indeed quite uncertain whether the body-cavity through which the alimentary canal runs is really a true coelome at all.

Towards the anterior end of the worm the body-cavity contains four remarkable structures known as the **phagocytic organs**, which can be distinctly seen as dark shadows if the fresh worm is held close to a strong light. In a dissection they are seen as small fluffy objects, of a pinkish or brownish colour, lying between the alimentary canal and the body-wall. Although arranged in two pairs the members of each pair are not exactly opposite one another but are arranged obliquely. Microscopic examination shows that each organ consists of an enormous cell, the body of which extends into tree-like branches which serve to anchor it to the body-wall and the intestinal wall. Both cytoplasm and nucleus of the cell are converted into a stiff material so that the cell and its branches are fairly rigid. This cell serves a mainly supporting function, its branches acting as supports to numerous little blobs of protoplasm which are perched all over them. These protoplasmic blobs are actively phagocytic, i.e. they serve to ingest solid particles of a harmful nature which may come to be in the fluid of the body-cavity.

The reproductive organs of *Ascaris* are of a characteristic type. In the female the external genital opening (Fig. 81, ♀) is a small pore, situated mid-ventrally in a slightly marked shallow groove which encircles the body at a very variable position in the anterior half or third of its length. This opening leads into a vagina and this at its inner end bifurcates to form the two uteri. Each uterus is a thick tube of considerable length, normally packed with eggs (Fig. 82, *ut*). The eggs are enclosed in thick shells of distinctive appearance (Fig. 90, B) and of extraordinary impermeability so that they may remain alive for many months after the adult is placed in a strong preserving fluid such as formalin. The uterus is continued into the oviduct (Fig. 82, *od*) a much narrower tube which normally contains scattered eggs without any shell—the eggs not yet having been fertilized—and this in turn is continued into the actual gonad. The gonad of the nematode is of very characteristic appearance, consisting of a greatly elongated thread which tapers off at its end into an extremely fine, freely ending, filament. In transverse section (Fig. 82, *ov*) the gonad shows an equally characteristic arrangement of genital cells radiating out from a solid core of protoplasm known as the **rachis**. As the gonad merges into the

oviduct this rachis breaks down so that the cells now lie loose in the cavity.

In the male the arrangement is similar as regards the most important points—the arrangement of the cells round a rachis and the direct continuity of the thread-like gonad with the tubular duct. But there is only a single gonad or testis in the male. Its duct serves as a seminal vesicle, in which the microgametes accumulate, and this opens not directly to the exterior but into the floor of the alimentary canal near the anus. The terminal piece of the alimentary canal into which the male duct opens has on its dorsal side two curved forwardly-projecting pockets each of which secretes a strong chaeta. These chaetae can be protruded through the genito-anal opening and are inserted into the external genital opening of the female at the time the microgametes are transferred.

GAMETOGENESIS AND FERTILIZATION

The reproductive organs of *Ascaris* are of special interest and importance from the fact that their study provided the foundation for much of our present-day knowledge regarding the origin and development of the gametes and their union in the process of syngamy or fertilization. We shall now make use of them in giving a description of these processes.

It has already been indicated that one of the chief characteristics of mitotic nuclear division is the concentrating of the nuclear material or chromatin into special little masses named chromosomes. What has not been mentioned, so far, is that the number of these chromosomes in the dividing nucleus is as a rule fixed and definite in the cells of any particular species of animal. This holds even for the period when the individual consists of a single cell or zygote. But seeing that the zygote itself arises in syngamy by the fusion of two gametes it necessarily follows that the gametes must contain each only half the normal number of chromosomes.

It thus comes about that there are two chromosome numbers characteristic of the species (1) the number characteristic of the ordinary cells of the body—known as the **diploid** number and (2) the number—half as great as the former—characteristic of the gametes and known as the **haploid** number.

The characteristic (diploid) number of chromosomes in a particular species of animal may be very large, as many as 168 in a little fresh-water crustacean (*Artemia*), while on the other hand it may be comparatively small. In *Ascaris megalocephala* the number is only four (in the case

of a particular variety of this species only *two*) and the smallness of this number is one of the main factors which have facilitated the following out of the details of the processes involved in gametogenesis and fertilization.

The study of sections through the long thread-like gonad of *A. megalcephala* shows its cells to be in a state of active multiplication, and each mitotic nucleus presents the diploid number of chromosomes—four (Fig. 83, A). This holds down to a certain level in the gonad but then there comes a remarkable change, as from now onwards each mitotic nucleus shows only two, i.e. the haploid number of chromosomes. Further, each individual chromosome has undergone a complication of its structure and has now the appearance of a bundle of four beaded rods in close apposition (Fig. 83, B). Each of these complex chromosomes is known as a **tetrad** from its quadripartite nature.

The reduction of the number of chromosomes from diploid to haploid—**meiosis** as it is termed—a necessary forerunner to the process of syngamy, is clearly a phenomenon of great importance and the interesting question arises—How is the reduction brought about?

A possible explanation readily suggests itself. It will have been noticed in Fig. 83, A, that the four chromosomes present before meiosis are split longitudinally. Now if these chromosomes were to become shortened and straightened and then come together side by side in pairs they would clearly give rise to the haploid number of tetrads. That this is a correct explanation is testified by a rare abnormality which has been observed in which two of the rods composing the tetrad were distinctly different in length from the other two.

Its correctness is also testified by much evidence derived from creatures other than *Ascaris* and the view is therefore now generally accepted that the reduction in number of the chromosomes is brought about by their coming together in pairs. This process of coming together is known as **syndesis**.

MALE (Fig. 84, left-hand figures)

The appearance of the tetrads is the inaugural phase of a mitotic division. The external boundary of the nucleus disappears and a spindle

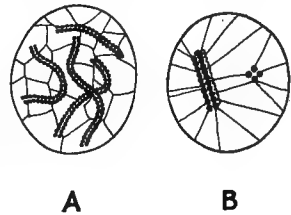

FIG. 83.

Nuclei from the testis of *Ascaris*. A, before and B, after the formation of the tetrads. (The right-hand tetrad in B is seen in end view.)

is formed (Fig. 84, A) having at each of its poles a minute, deeply-staining, particle, the **centrosome**. The two tetrads lie at the equator of the spindle and each becomes split apart into two halves—**dyads**—which gradually

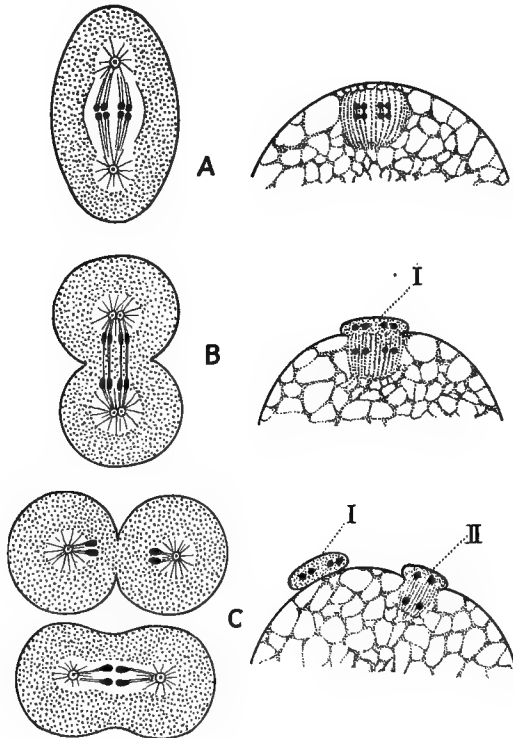

FIG. 84.

Maturation of the gametes in *Ascaris*—male on the left and female on the right (after Brauer and Boveri). A, Commencing first meiotic division—the two tetrads are seen at the equator of the spindle—a centrosome is present at each pole of the spindle in the male but not in the female. B, The first meiotic division nearly complete, the two daughter cells—each containing two dyad chromosomes—are equal in size in the male but very unequal in the female. C, Second meiotic division. In the male each of the two cells resulting from the preceding division is dividing, the upper cell being shown at a later stage than the lower. Each cell contains two monads and a centrosome. In the female the daughter cells are again very unequal ("Egg" and second polar body). I, first polar body; II, second polar body. (In B—left hand fig.—the centrosome at each pole of the spindle has precociously divided into two, in preparation for the second mitosis.)

recede from one another towards the poles of the spindle, possibly owing to the contraction of spindle fibres attached to them (Fig. 84, B). As the dyads move apart a constriction appears round the equator of the cell which gradually deepens until the cell-body is completely divided

into two. It will be noted (1) that each of the daughter cells contains two, i.e. the haploid, number of chromosomes and (2) that each individual chromosome is a dyad.

Each of the two cells repeats the process of mitosis. A spindle is again developed, having at its poles centrosomes arising by the division of the original centrosome, and the two dyad chromosomes arrange themselves at its equator (Fig. 84, C, lower half), and become split into their two constituent halves which move apart towards the poles of the spindle as **monad** chromosomes. The cell-body becomes as before constricted into two cells—each of which again contains the haploid number of chromosomes, these being now monad or single in their nature, together with a centrosome (Fig. 84, C, upper half).

Thus the original cell from which we started is now represented by four cells. Each of these cells (**spermatids**) gradually takes on the form of a functional microgamete or spermatozoon. This (Fig. 86, 4) is quite unlike the spermatozoa of most animals in appearance, being somewhat conical in shape with a rather expanded base of soft protoplasm, by the amoeboid movement of which the spermatozoon creeps. Within this lie the two chromosomes and the centrosome, while the apical portion is filled by a clear glassy body of unknown function.

FEMALE (Fig. 84, right-hand figures)

In the ovary just as in the testis there is a special level at which the mitotic nuclei show chromosomes tetrad in structure and haploid in number. The cells are larger owing to the cytoplasm being distended by large granules of reserve food-material or yolk. As mitosis commences a spindle makes its appearance as in the male with the two tetrad chromosomes at its equator, but this spindle is devoid of centrosomes and it is situated close under the surface of the cell, with its axis in a radial direction, i.e. perpendicular to the surface (Fig. 84, A). Each tetrad splits apart into two dyads and then the cell divides but instead of the two daughter cells being of approximately equal size, one of them is reduced to the smallest dimensions, consisting of hardly more cytoplasm than is just sufficient to contain the two dyads. This tiny cell is known as the **first polar body** (Fig. 84, B, I).

The mitotic process is repeated in the large cell. Each dyad becomes rotated through a right angle so that it takes up a radial position: its constituent monads move apart towards the poles of the spindle. The cell as a whole divides, and again one of the two daughter cells

is quite tiny—forming the **second polar body** (Fig. 84, C, II)—while the large cell is now the macrogamete or mature egg.

Occasionally the smaller of the two cells formed by the first division, i.e. the first polar body, also divides with mitosis into two daughter cells each containing two monads—but as a rule this division is suppressed. Its exceptional occurrence is however of importance for in such a case we see clearly the fundamental identity of the processes at work in the male and female gonad. In each case the cell in which the reduced number of (tetrad) chromosomes makes its appearance gives rise by two mitotic divisions in rapid succession to a set of four cells each containing the reduced number of chromosomes monad in character. These two divisions, associated with the reduction in the number of chromosomes, are known as the first and second **meiotic or maturation divisions**.

The conspicuous difference between the two sexes is a comparatively superficial one, namely that in the male each one of the four cells resulting from the meiotic divisions becomes a functional gamete, while in the female only one does so, the other three being the reduced, functionless polar bodies.

Here we have come in touch with the most characteristic difference between the gametes of the two sexes throughout the animal kingdom. The female gamete is relatively large in size, frequently containing a store of reserve food-material or yolk, and is incapable of active movement: whereas the male gamete is relatively small, without stored food-material, and active in its movements. The fact that three out of each four potential macrogametes degenerate is no doubt an adaptive arrangement facilitating the increase in size of the fourth, necessary to enable it to contain a sufficient store of yolk.

The act of syngamy between the two gametes, the “fertilization of the egg” to use the older name, takes place in the cavity of the uterus, into which a supply of microgametes has been passed by the male through the external genital opening.¹ A single microgamete attaches itself by its broad end to an egg (Fig. 85, A) and the nuclear material from it passes, together with the centrosome, into the cytoplasm of the egg. The two nuclei which now are in the cytoplasm—the original egg nucleus (N) and the immigrant sperm nucleus (n)—undergo a gradual increase in size, the two chromosomes in each becoming lengthened out into slender meandering filaments. Eventually

¹ For the sake of clearness we describe the processes of maturation and syngamy in their logical sequence but as a matter of fact in *Ascaris* the two processes overlap, the formation of the polar bodies being delayed until after the microgamete has entered the egg (cf. Fig. 85, A).

the two nuclei are absolutely identical in appearance (Fig. 85, C). The two nuclei gradually approach one another, the centrosome—surrounded

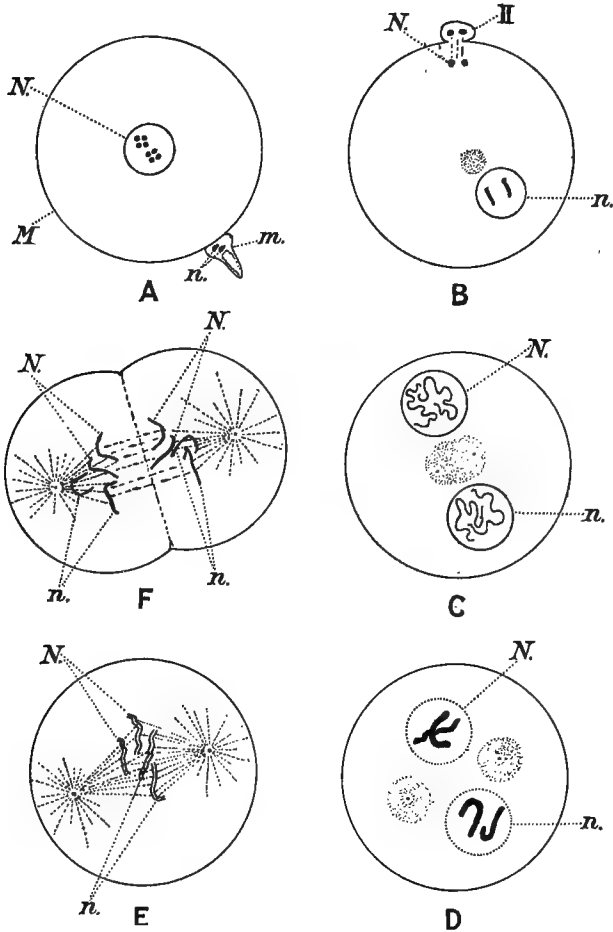

FIG. 85.

Diagram illustrating syngamy in *Ascaris megaloccephala*. A, Commencing fusion of microgamete with the egg before formation of polar bodies; B, formation of second polar body; C, two gamete nuclei alike, each chromosome drawn out into a long thread; D, shortening of chromosomes, separation of centrosomes; E, mitotic spindle with split chromosomes; F, division of zygote into two daughter cells. *M*, Macrogamete; *m*, microgamete; *N*, egg nucleus; *n*, sperm nucleus; *II*, second polar body.

by an area of deeply staining cytoplasm—lying between them. The centrosome divides into two—the two gradually receding from one another. Meanwhile the two chromosomes of each nucleus become greatly shortened

up so as to take the form of stout curved rods (Fig. 85, D). The boundaries of the two nuclei disappear so that the chromosomes lie free in the cytoplasm, and a spindle makes its appearance, fibres passing from the chromosomes which lie about its equator to each centrosome and radiating out from the centrosome into the surrounding cytoplasm. Each chromosome splits longitudinally (Fig. 85, E) and its two halves slowly recede towards opposite poles of the spindle (Fig. 85, F). Thus there travel towards each pole four daughter chromosomes, two of which (n) are of paternal origin—derived from the sperm chromosomes, two (N) of maternal—derived from the egg chromosomes. The egg now becomes surrounded by a furrow round its equator which gradually deepens until the egg is completely divided into two daughter cells. This division is the first step in the development of the new individual, the first step in the process known as the **segmentation** of the egg. The important point to notice is that the chromosomes in each of the two daughter cells or **blastomeres** are diploid in number, and are half of paternal and half of maternal origin. Throughout subsequent development, as the blastomeres divide over and over again to form the immense mass of cells constituting the adult body, the process of splitting is repeated at every mitosis, so that each cell in the body contains nuclear material derived equally from the two parents.

When eventually, in the gonad of the new individual, the process of syndesis takes place there is reason to believe that the two chromosomes that come together are one of paternal origin and one of maternal. The evidence on which this belief is based comes not from *Ascaris* but from other animals but it is possible to indicate in a few words its nature.

It has been possible by detailed study of the chromosomes of various animals to determine that any particular species is characterized not merely by the definite *number* of its chromosomes but also by definite characters of the individual chromosomes. Thus in the developing gametes the haploid group is constant not merely in its number but in its composition. It is made up of a definite assemblage of chromosomes showing small differences in size and shape which make it possible to recognize them individually and to label them with definite designations, such as letters of the alphabet. Thus supposing the haploid number is six it may be possible to distinguish a, b, c, d, e, f, each characterized by definite shape and size. In each haploid group we find the same set of chromosomes recurring—each recognizable by its special peculiarities. It follows that after syngamy there is present in the diploid group a double set of chromosomes—2a, 2b, 2c, 2d, 2e, 2f. The corresponding chromosomes—the two “a” chromosomes for example—are known technically

as **homologous chromosomes**, and it is obvious that in each homologous pair one chromosome is paternal in origin and the other maternal.

Now when syndesis occurs it is found in cases such as I have described that the two chromosomes that come together are always homologous. We are justified then in defining syndesis in general as the pairing or coming together of the homologous chromosomes.

We have seen how, in *Ascaris*, the process of syndesis is the inaugural phase of the first meiotic division and how in the course of the two meiotic divisions each tetrad becomes resolved into its four constituent monads. It is clear that in this latter process there take place (1) separation of the two chromosomes which came temporarily together in syndesis and (2) separation of the two halves into which these chromosomes were already split before syndesis took place.

In *Ascaris* it is difficult to decide by actual observation what is the order in which these two separations take place, but—judging by the analogy of many other animals in which the matter has been worked out decisively—we are justified in regarding it as probable that they take place in the order named. In other words the retreat of the homologous chromosomes from one another after their temporary apposition takes place in all probability in the first of the two meiotic divisions.

We have described the more conspicuous features of the processes of maturation and syngamy in *Ascaris* but it is now necessary to say something about a complication in detail—difficult to observe but of great importance—which has been discovered in the course of recent research.

The kernel of the discoveries in question consists of the fact that while the macrogametes are all alike, the microgametes on the other hand are divisible into two distinct types, one of which produces a male and the other a female zygote when it fuses with a macrogamete. We are consequently brought directly into touch with one of the great problems of zoological science—the determination of sex.

It turns out that the cell of the testis which shows the two tetrad chromosomes possesses in addition to these a small **sex chromosome** (Fig. 86, 1, α). This may be distinct or, as is much more frequently the case, it may be unrecognizable through being fused with one of the large tetrads. Now when this sex chromosome is traced through the two meiotic divisions it is found that in one or other of these divisions it passes bodily over to one of the two daughter cells instead of being divided between them. Thus in Fig. 86, A, 2, it is seen that the sex chromosome has passed bodily over into the upper cell in the first meiotic division. It becomes however shared between the two daughter cells in the second

meiotic division, so that of the four resulting microgametes two are provided with sex chromosomes while two are without.

The same end-result is arrived at in Fig. 86, B, although here it is the second meiotic division in which the sex chromosome passes over bodily.

A sex chromosome occurs also in the egg before meiosis but in this case it is distributed in the ordinary manner at each division and one is therefore present in every ripe macrogamete.

Syngamy taking place at random between large numbers of microgametes and macrogametes will clearly result in the formation of two types of zygote in approximately equal numbers—the one type differing

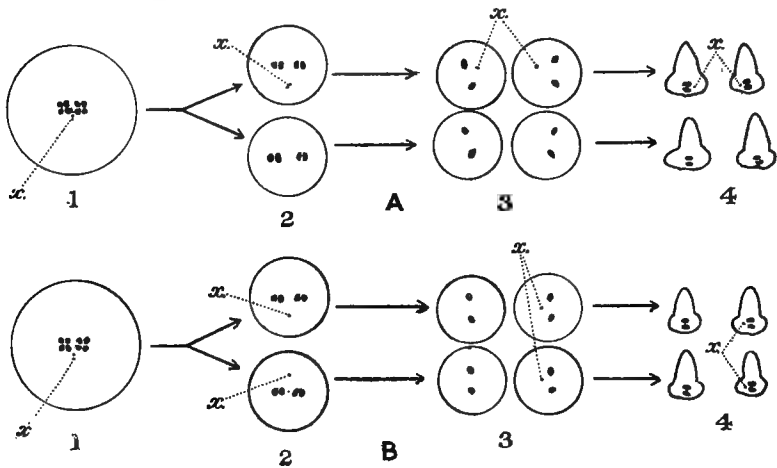

FIG. 86.

Diagram showing the behaviour of the sex chromosome (x) during the meiotic divisions in the male *Ascaris*. A, Sex chromosome remains undivided in the first meiotic division; B, sex chromosome remains undivided in the second meiotic division.

from the other in having an extra sex chromosome brought in by the microgamete. It follows that the adult individuals into which the zygotes develop will similarly be divided into two types the one differing from the other in the fact that each of its cells contains two sex chromosomes in place of one. The former are the female individuals, the latter the male: and the sex of the individual would appear to be the result of pure chance—according as the macrogamete is fertilized by a microgamete containing the extra sex chromosome or by one which is devoid of it.

It will be seen that the recognition of these additional facts concerning the sex chromosome involves an emendation of the statement on p. 182 that in *A. megalcephala* the diploid number of chromosomes

is four. To make the statement complete we must say the diploid number of chromosomes is in the male $4 + x$ and in the female $4 + 2x$, x being the inconspicuous sex chromosome.

DIFFERENTIATION OF SOMA FROM GONAD

Another series of phenomena of great general interest which have been worked out more fully in *Ascaris megalocephala* than in any other animal have to do with the marking off of those cells which constitute the soma from those of the gonad. In *A. megalocephala* this has been found to occur at the earliest possible stage of development—when the zygote has divided into its first two blastomeres. As these commence the next mitosis a difference becomes apparent between them. In one the process is perfectly normal, the four chromosomes undergoing longitudinal splitting precisely as in the first mitosis. In the other blastomere however before the chromosome splits it undergoes transverse segmentation. The swollen club-shaped ends of the chromosome drop off, while the more slender central portion segments up into a number of little pieces (Fig. 87, I, left-hand nucleus). It is only these small pieces which undergo the splitting process and enter into the composition of the nuclei of the two daughter cells. The club-shaped ends are simply left lying in the cytoplasm, by which they are gradually digested and destroyed. The result is that in the four-blastomere stage (Fig. 87, II) two cells have nuclei with the full amount of chromatin while the other two have nuclei with greatly diminished amount of chromatin. With this diminution in the amount of chromatin the last-mentioned two cells have become **somatic cells**. Throughout the numerous subsequent mitoses during the course of development the descendants of these cells remain with nuclei relatively poor in chromatin.

When the two blastomeres (of the 4-cell stage) whose nuclei contain the full amount of chromatin undergo mitosis one of the two repeats the process of eliminating the club-shaped ends of its chromosomes, so that two more somatic cells are produced, while the other cell divides normally so that there are again in the 8-cell stage two cells with the full amount of chromatin.

Exactly how often this process of diminution of the chromatin is repeated in normal cases—whether three times as in the figure, or four times or five times—is not absolutely determined, but in any case the end-result, when it has taken place for the last time, is that all the cell-nuclei of the embryo have undergone, or in the case of one nucleus are undergoing, the process of diminution so that one nucleus alone retains

the four unmodified chromosomes. This latter cell (the thick arrow at the top of Fig. 87 points to it) is the **primordial germ-cell**, the ancestor of all the cells that constitute the gonad of the individual.

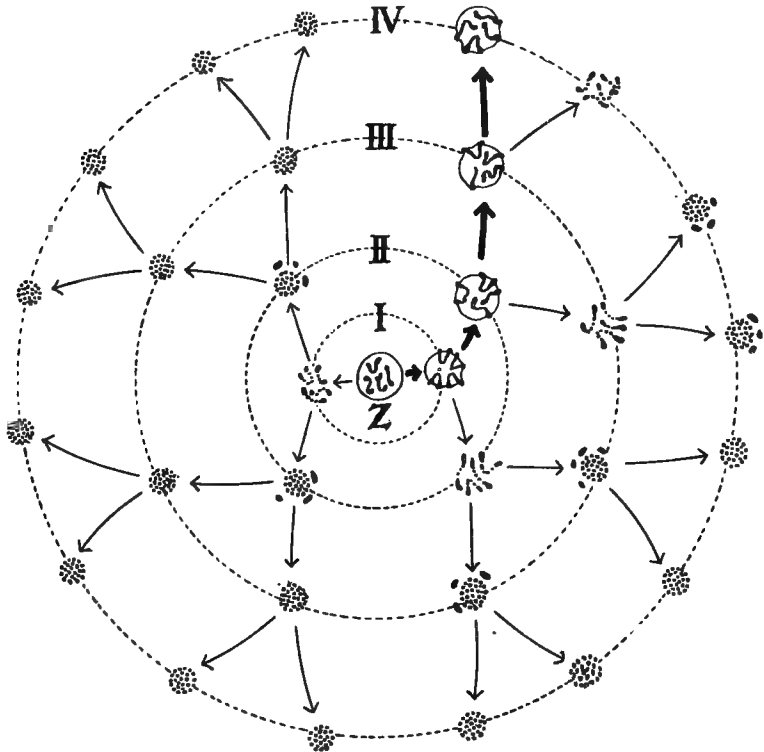

FIG. 87.

Diagram to illustrate the nuclear differentiation of soma from gonad in *Ascaris megalocephala*. Z represents the zygote-nucleus with its four chromosomes. I, II, III, IV represent successive generations of nuclei descended from the original zygote-nucleus. I—two nuclei, those of the first two blastomeres. That on the left (somatic) shows the commencement of the process of chromatin diminution. II—4-cell stage. The two nuclei on the left have undergone diminution: the cast-off ends of the chromosomes are seen outside the nuclei. Of the two nuclei on the right the lower shows commencing diminution. III—8-cell stage. Of the eight nuclei, six (somatic) have undergone diminution, one (to the right) is commencing diminution, and the remaining one retains the four chromosomes unaltered. IV—16-cell stage. Of the 16 nuclei, 14 (somatic) have undergone diminution, and of the remaining two (above and to the right) one (somatic) is commencing diminution while the other retains the normal four unmodified chromosomes. The last mentioned is the primordial germ-cell—the ancestor of all the cells of the gonad.

During subsequent development the cells go on dividing with ordinary mitosis—vast numbers of cells poor in chromatin forming the complicated soma of the adult: vast numbers of others with the full amount

of chromatin constituting the gonad and eventually developing into functional gametes in the way already indicated.

The phenomena that have been described are of much importance in relation to the known facts of heredity. In the first place it may be recalled how the study of the Protozoa brought out the fact that the nuclear material of the cell plays an important part in governing and controlling its vital activities.

When we study the phenomena of inheritance in animals in general, one of the most striking features of these phenomena is seen to be that, on the whole, the two parents contribute in equal parts to the characters of the offspring. It is clear in a large proportion of cases that the total inheritance of the young individual is already contained within the zygote, for this may go through the complete course of its development into the new individual under conditions which render it impossible that any moulding influence can be exercised by the parent. Consequently the inheritance must have been brought into the zygote, and brought in in equal parts, by the two gametes. Therefore the material basis of inheritance, the special substance whatever it is that carries inheritable qualities, must be contributed to the zygote in equal quantities by the two gametes. These two gametes may of course be enormously different in their size, for example in a bird the macrogamete may be millions of times the size of the microgamete—but the evidence of *Ascaris*, and also of many other animals, indicates that, in spite of superficial differences in the size of the two gametes, there is one element contributed in approximately equal parts by the two gametes, namely the chromatin of the nucleus apart from the sex-chromosome. As there is so far no evidence to prove that this holds for any other substance, the presumption is obviously very strong that the chromatin is the vehicle which carries the hereditary qualities.

Another striking feature of heredity is the way in which it permeates every portion of the body. In any part of the body, in any tissue, a feature may make its appearance which has clearly been inherited from one or other parent. But we have already seen how the ordinary chromosomes of the zygote, derived half of them from one parent and half from the other, are at each one of the countless mitoses which take place during the development of the individual accurately split into two halves, one going to the one daughter cell and one to the other, so that the metabolism of every resultant cell is controlled by chromosomes half of paternal origin and half of maternal. Clearly this fits in perfectly with the idea that the chromatin is the bearer of heredity.

Still another point. One of the striking features of heredity is that

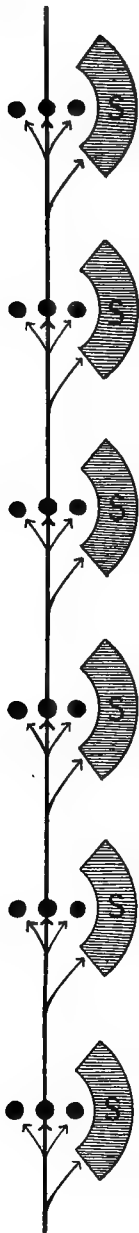

expressed in the familiar statement that "Acquired" characters, or to use a preferable expression *Impressed* characters, are not inherited. By this is meant that characters impressed upon the soma during its life, such as local injuries caused by wounds or disease, or changes in size of an organ brought about by increased or decreased use, are not passed on to the descendants. This fact, at first sight remarkable, becomes less puzzling when we see in *Ascaris* how the cells of the soma become marked off at the very earliest possible stage of development as a race of cells apart from those of the gonad and never give rise to true reproductive cells. The latter, the cells which will develop into the individuals of succeeding generations, are in fact not derived from the soma upon which the character was impressed, but are rather persisting portions of the ancestral reproductive substance or gonad from which that soma itself was derived.

There is indeed a continuous streak of gonad—the **germ track** as it is called—which comes down through the ages in any chain of descent and the somas or bodies of successive individuals are simply shed-off or side-tracked portions of this (Fig. 88). The soma is not the parent of the gonad, it is merely the foster parent or nurse which has charge of its portion of gonad—conveying it about, protecting, and nourishing it.

In the last few pages we have made use of *Ascaris megalocephala* for illustrating some of the basic facts of **cytology**—the department of biology which concerns itself with the detailed study of cells—relating more especially to the reproductive cells. These facts are of the greatest importance and we will therefore emphasize them by a few additional comments.

(1) It will be recalled that the study of the Protozoa taught us to regard the nucleus of a cell as that portion of its protoplasm or living substance in which is concentrated control over its living activities.

FIG. 88.

Diagram illustrating the side-tracking of soma from gonad. The diagram represents a portion of the germ-track passing through individuals of six successive generations. Each group of three black circles represents the gonad of an individual, enclosed within its soma (S).

(2) As has already been indicated it is a general characteristic of heredity that, upon the average, the inherited qualities of the individual are derived equally from the two parents. If therefore inherited qualities have a material basis this must consist of a substance derived in approximately equal amounts from the two parents. *Ascaris* has shown us that there is one such substance (and there is no evidence of any other) namely the substance of the ordinary chromosomes. We are therefore justified in the belief that this substance is the material basis or "vehicle" of heredity. It is necessary that we should guard ourselves from forming too definite a conception of this chromatin as a substance of fixed chemical and physical constitution. We should regard chromosomes primarily as portions of the living substance or protoplasm in which certain living activities are concentrated. The physical and chemical features—staining properties, high refractive index and so on—which make the chromosomes recognizable by the sense of sight are to be regarded as relatively superficial accompaniments.

(3) Syngamy, involving the union of two nuclei, is necessarily accompanied by meiosis, to keep the chromosome number constant and prevent it from being doubled at each successive syngamy.

(4) Syndesis, the temporary pairing of homologous chromosomes, is apparently an essential part of the process of meiosis. Its primary meaning is probably to make use of the existing mechanism of mitosis for transferring entire chromosomes—instead of split halves—to the two daughter cells, thus ensuring that the latter shall contain only the haploid number. While we have there the probable primary meaning of syndesis it is well to bear in mind that in such a case as *Ascaris* where the two homologous chromosomes lie in close apposition side by side their proximity to one another may provide the opportunity for possible exchange of substance between the two chromosomes, or for the exercise of mutual influence in more obscure ways.

(5) The fact that maternal and paternal chromosomes are alike distributed during the course of development to every cell in the body is an important bit of confirmatory evidence to the conclusion, already stated under (2), that the substance of these chromosomes affords the material basis for heredity.

(6) In the process of mitosis, which is the almost universal mode of nuclear division all through the animal kingdom, perhaps the most characteristic feature is the remarkable longitudinal splitting of the chromosomes. In fact we might define the mechanism of mitosis as a mechanism for the accurate splitting of the chromosome into two halves and the distribution of these two halves to the two daughter cells.

Now the general occurrence of this longitudinal splitting would appear to carry with it a very interesting logical conclusion namely that the substance of the chromosome is not homogeneous throughout its extent, but differs in quality from point to point along its length. Only on this assumption does it become clear why the chromosome splits longitudinally—namely in order that every quality spaced out along its course may be equally shared between the two daughter chromosomes.

In relation to the phenomena of heredity we appear then to be justified in the belief that not only are hereditary qualities in general carried by the chromosomes but that different hereditary qualities are localized in different portions of the individual chromosome.

(7) In the description of the mitotic process reference has been made to the centrosomes and to the fibrils which constitute the spindle. The student should guard himself against regarding these as discrete structures apart from the cytoplasm. They are to be regarded rather as special local modifications of the cytoplasm, its constituent particles undergoing temporary re-arrangement under the stress of some unknown physical influence, in somewhat similar fashion to that shown by iron-filings in a magnetic field. The centrosome would appear to be the centre from which this influence, whatever it may be, radiates.

(8) Sex chromosomes were first observed in insects and even to-day by far the greater number of clearly-worked-out cases belong to this group of animals, most of our knowledge having been accumulated by American cytologists. Apart from Insects and Nematodes they have been observed in many other cases scattered through the animal kingdom. The case of *Ascaris* shows us how sex chromosomes even when present may be unrecognizable through being fused with ordinary chromosomes and we may take it as probable that a similar explanation accounts for their unrecognizability in other types where they appear to be absent and that the presence of such chromosomes is really a general characteristic of the sexual differentiation of gametes.

In cases where sex chromosomes are definitely known to occur they exhibit differences in detail, in numbers and so on, which need not be gone into in this book.

The main lessons which the sex chromosome phenomena of *Ascaris* teach us are these :

- (a) That in the animal in question the microgametes consist in equal numbers of two different classes,
- (b) That these two classes differ from one another in the fact that they produce, when they undergo syngamy, zygotes of opposite sexes, and
- (c) That the male-producing type is characterized by the fact that it

extrudes the sex chromosome bodily in one or other of the two meiotic divisions.

Care must be taken not to attribute necessarily any active sex-determining rôle to the sex chromosomes: the present state of our knowledge does not justify any such conclusion. All that we are strictly justified in saying is that the extrusion of the sex-chromosome in one type and its non-extrusion in the other provides us with a kind of label indicative of a deep-seated sex-producing difference between the two sets of microgametes.

Whether the existence of two different sex-producing types of microgametes is to be regarded as the normal cause of the determination of the sex of the sexually-produced individual throughout the animal kingdom is a question to which a definite answer must wait for future research. Probability appears on the whole to point to this answer being in the affirmative.

(9) Lastly we have seen how the "germ track" is continuous from generation to generation—the bodies of the successive individuals in a chain of descent being as it were "side-tracked" from it. Here we are in touch with one of the most impressive ideas in biological science namely that the living substance of each creature existing on the earth to-day is continuous right back through the eternal past with the living substance which first came into existence in the dawn of the evolution of living things.

Various nematode worms are liable to occur as parasites of man and we will now survey the life-histories of a few of the more important of these.

TRICHINA

T. spiralis, the female of which measures about 3-4 mm. in length and the male about 1.5 mm., is apparently primarily a parasite of the rat, although it is liable to spread to many other animals including man. The worms reach maturity in the small intestine. After the act of fertilization the male dies while the female grows rapidly to its full length, bores into the intestinal wall and settles down there in the connective tissue. At about the sixth day the birth of young commences: it continues during several weeks, a single female producing many thousands of young larvae.

The larvae, which measure about .1 mm. in length, pass along the lymph spaces and a large proportion of them eventually reach the blood-stream and are by it distributed through the body. These larvae are small

enough to pass easily through the capillary network but when they find themselves traversing the capillaries of a muscle—particularly if it be one of the more active muscles such as the diaphragm—they bore their way out of the capillary and pass in amongst the muscle fibres. After spending some time, it may be several days, migrating through the muscle, the young worm curls itself up into a spiral and settles down in a resting condition between the muscle fibres (Fig. 89), the connective tissue round it reacting to its presence by enclosing it in a lemon-shaped cyst about .4 mm. in length.

Within its cyst the young *Trichina* may retain its vitality for many

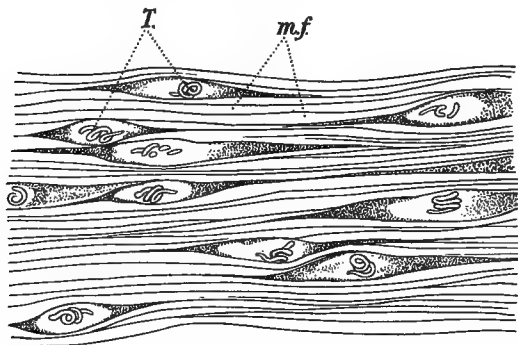

FIG. 89.

Larval *Trichinae* encysted in muscle. $\times 26$. *mf*, Muscle fibres; *T*, *Trichinae*.

years but this is unusual and as a rule after a few months or years the cyst undergoes calcification.

No further development takes place unless the muscle containing the *Trichina* is swallowed by a suitable animal. When this happens the young worm is set free by the digestion of the cyst: it rapidly—within from one to two days—attains to sexual maturity and the life-cycle is started afresh.

Pigs are particularly liable to become infected, probably through eating the flesh of an infected rat, and then the infection is liable to be conveyed to man by his eating insufficiently cooked pork or ham containing the encysted worms. As the infection is liable to be a heavy one, resulting in the presence of many millions of young worms within the body, severe symptoms of disease (**trichinosis**) are produced—more or less cholera-like symptoms during the intestinal stage, and high temperature accompanied by severe muscular pains during the period of migration.

An important duty of public health authorities consists in the systematic inspection of pork and ham, especially when imported from abroad, to make sure that it does not contain encysted *Trichinae*.

ASCARIS

A species of *Ascaris* (*A. lumbricoides*), resembling that already described in detail but rather smaller in size (δ 15-25 cm., ♀ 20-40 cm.), is a common parasite of man all over the world. Normally it inhabits the small intestine though it may wander into other parts of the body. Its presence in the alimentary canal may be determined by the eggs

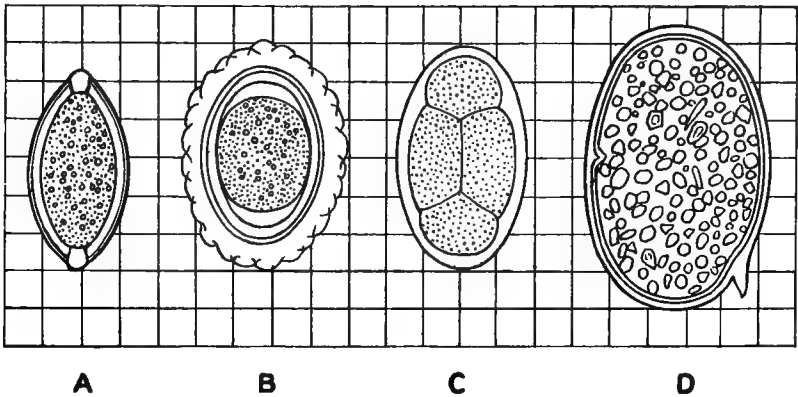

FIG. 90.

Eggs of parasitic worms from the intestine of Man. They are drawn as resting on a slide ruled in squares with lines $10\ \mu$ (i.e. .01 mm.) apart. A, *Trichocephalus* (the commonest egg of the four); B, *Ascaris*; C, *Ancylostoma*; D, *Schistosoma japonicum*.

in the faeces (Fig. 90, B). These eggs are ellipsoidal and are enclosed in a thick envelope with knobbed surface measuring about $60\ \mu$ in length. They do not normally show any signs of developing until they reach the exterior where in moist earth the eggs segment and give rise to embryos. If swallowed by a human being these hatch out in his alimentary canal and in about five weeks are sexually mature and producing eggs.

TRICHOCEPHALUS

Trichocephalus (Fig. 91) is a very common and as a rule harmless inhabitant of the alimentary canal of man, where it is found most frequently in the caecum. It measures about 40-45 mm. in length in the

male and 45-50 mm. in the female, and it is easily recognized by the fact that the anterior portion of the body forms a fine filament which is threaded through the intestinal lining and serves to anchor the worm in position. The eggs, of an elongated ellipsoidal form and measuring about 52μ in length by 23μ in width (Fig. 90, A), pass to the exterior and if the soil is moist go on developing to an advanced embryonic stage. If swallowed at this stage—which may last for a prolonged period—the young worms hatch out in the alimentary canal of their new host and in about a month are mature and producing eggs.

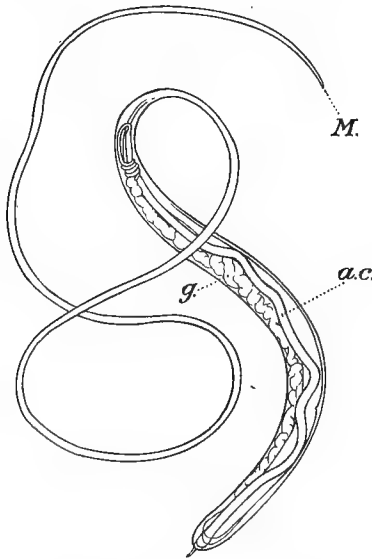

FIG. 91.

Trichocephalus trichiura ♀ × 6. a.c., Alimentary canal; g, uterus; M, mouth.

OXYURIS

O. vermicularis is a small nematode (♂ 3-5 mm., ♀ 10 mm.) which occurs in the large intestine of man and is the usual cause of the complaint popularly known as "worms" in children. The female when ready to deposit the eggs travels down the intestine towards the anal opening and the eggs are deposited either on the skin or in faecal matter. If swallowed there hatches out from the egg a young worm which develops into an adult like the parent.

ANCYLOSTOMA

The Miner's Worm or Hook-worm (*Ancylostoma duodenale*) although small in size (♂ about 10 mm., ♀ about 12-13 mm.) is yet a very dangerous parasite of man, for it is liable to occur in the small intestine in enormous numbers and cause profound anaemia. It occurs in practically all the warmer parts of the world and is particularly prevalent in Egypt and some parts of India, and in the Southern States of North America. In colder climates it is apt to be introduced and flourish amongst workmen where the necessary conditions of warmth and moisture are present, as in tunnels and mines. In mining districts its appearance should always be borne in mind as a possible danger.

Apart from the general features characteristic of a small nematode the most striking characteristics are two. (1) The mouth opening (Fig. 92, A) has become shifted on to the dorsal surface of the head, and there project into its cavity upon each side two strong recurved spines. A little further back there projects upwards from the floor of the cavity a pair of flat cutting blades. (2) In the male (Fig. 93) the edges of the anal opening project into a conspicuous thin flap on each side which serve to grip between them the body of the female.

The mature worms are to be found especially in the small intestine, holding on by their hooks and feeding on the lining epithelium and the underlying connective tissue with its capillaries.

The eggs (Fig. 90, C), ellipsoidal in shape and enclosed in a delicate shell measuring about $60 \mu \times 37 \mu$, are laid in the intestine and pass to the exterior amongst the faeces. If conditions are favourable—the ground being moist and the temperature warm (25° - 35° C.)—the egg hatches out within a couple of days as a small larva about a quarter of a millimetre in length. These larvae have pointed tails and show certain resemblances to another genus *Rhabditis* from which fact they are often spoken of as the Rhabditis-stage. The larva feeds actively on faecal matter, grows to about double its original length, and casts off the outer layer of its cuticle. This process of moulting is repeated but this time the shed cuticle remains as a loose membranous sheath round the body of the worm. The worm now—a week to ten days old—has lost the Rhabditis characteristics; it ceases to feed and becomes sluggish in its movements but is capable of remaining alive for several months so long as it is kept wet. It is this stage, after the second moult, that is alone capable of infecting a new mammalian host.

This may take place through the worm simply being swallowed, for example in drinking water or among insufficiently cleaned vegetables. But Looss discovered by a personal accident that the *Ancylostoma* may find its way to its destination by a much more circuitous route. While carrying on investigations in his laboratory in Cairo he let fall on his hand a

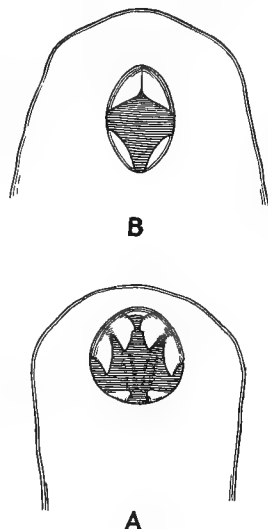

FIG. 92.

Enlarged view of dorsal side of head end of A, *Ancylostoma* and B, *Necator*, to show the buccal cavity.

drop of water containing numerous *Ancylostoma* larvae. Within a few minutes a burning sensation and a distinct reddening of the skin became apparent and he found that the larvae had disappeared into the skin, leaving their empty cuticular sheaths behind. An experimental repetition upon the skin of a limb an hour before amputation disclosed the larvae

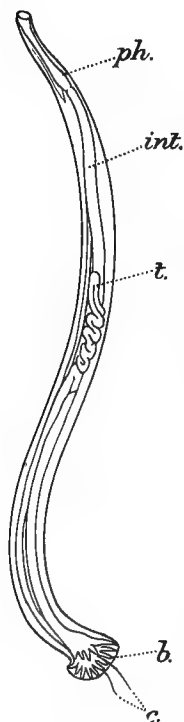

FIG. 93.

Ancylostoma duodenale,
 $\delta \times 10$. *b*, Projecting
 flap; *c*, chaetae; *int.*, in-
 testine; *ph*, pharynx;
t, testis.

in the act of burrowing through the skin, their entry being as a rule by way of the hair follicles. The exact route from the skin to the intestine was determined by experiments on puppy-dogs with another species of *Ancylostoma* (*A. caninum*). It was found that the larvae make their way into the blood-stream either directly through the veins of the skin or by way of the lymphatics. Carried round the circulation they reach the lung and there bore their way out of the blood-vessel into the pulmonary cavity. From this they migrate up the trachea or windpipe and thus reach the oesophagus en route for the intestine. There is no reason to suppose that the *Ancylostoma* of man differs in these migrations from that of the dog.

It is very surprising to find in an intestinal parasite like *Ancylostoma* the existence side by side of two distinct modes of infection, one of them the simple method which we should expect in the case of a parasite of the alimentary canal by ingestion through the mouth, the other by the unexpectedly roundabout route through the skin. The suspicion suggests itself that in *Ancylostoma* we have to do with a parasite which formerly inhabited not the alimentary canal but the connective tissue, obtaining access to it by boring through the skin, but which has comparatively recently become a parasite of the alimentary canal, not yet however having had time to get rid entirely of its former habit of entering the body through the skin.

After reaching the intestine, by whichever route, the *Ancylostoma* rapidly reaches sexual maturity and the first eggs make their appearance in 8-10 weeks.

In localities where *Ancylostoma* is prevalent the obvious precautions to take are (1) to avoid drinking or using for kitchen purposes water that may possibly contain living larvae, and (2) to avoid letting the skin come

in contact with moist soil possibly contaminated with faecal matter. In mines in temperate climates, whither the parasite may be brought by infected immigrants, the chief precaution to be taken to prevent it from establishing itself is strict sanitary control, to avoid the possibility of eggs becoming scattered about the ground in faecal matter: keeping the temperature down below 25° C. by efficient ventilation, and efficient drainage are also when practicable of importance.

NECATOR

Over many parts of Africa, India, the West Indies and the warmer parts of the American continent (extending into the Southern States of North America) there occurs, either alone or associated with *Ancylostoma*, another Hook-worm which is placed in a distinct genus—*Necator*. While agreeing with *Ancylostoma* in the main features of its structure and life-history *Necator* can be distinguished by certain details. It is slightly smaller (♂ 8 mm., ♀ 10 mm.): the head is bent more sharply towards the dorsal side than is the case with *Ancylostoma*: and the two recurved teeth are replaced by a flat cutting plate (Fig. 92, B) which meets its neighbour in the middle line.

DRACUNCULUS

The Guinea Worm—*Dracunculus*¹ *medinensis*—is a well-known parasite of man, as well as of the dog and various other mammals, in suitable localities throughout the warmer parts of Africa and Western Asia. It has also been introduced into Fiji and here and there in tropical America.

The parasite lives in the connective tissue of the host, the male being comparatively small (22 mm., Leiper) but the female reaching a length of up to about 120 cm. with a thickness of a little under 2 mm. The full-sized female, about a year old, is practically filled by the enormously dilated uterus containing millions of eggs, the alimentary canal degenerating especially in its hinder portion and the anal opening becoming completely occluded.

After fertilization has taken place the male apparently dies. The female, as the embryos within the eggs develop, slowly migrates towards some portion of the host's skin which is liable to be wet—ordinarily towards the foot or ankle, but in the case of water-carriers accustomed to carry water in skins or other vessels upon their backs or heads towards

¹ Sometimes called by the older name *Filaria medinensis*.

that portion of the body. The head of the worm bores towards the surface and the epidermis rises up over it as a blister which presently bursts, forming a small ulcer with the opening of the burrow in which the worm lies in its centre.

If now the ulcer comes into contact with cold fresh water the worm contracts the muscular wall of its body and forces out a portion of its uterus, which immediately bursts and exudes a drop of milky-looking fluid, containing myriads of young worms coiled up in spiral form. These larvae measure usually from .5 mm. to .75 mm. in length, are somewhat flattened, and have the hinder end of the body drawn out into a fine point.

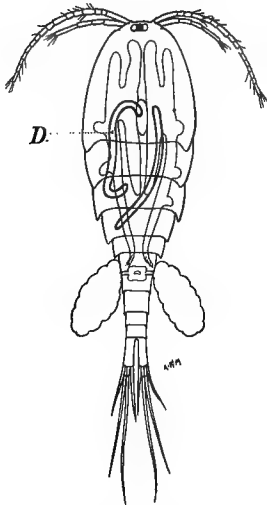

FIG. 94.

Cyclops, ♀ containing two
Dracunculus larvae (D).

Contact with the water rouses the larvae to activity. They uncoil themselves and swim away rapidly. They are capable of remaining alive for a period of up to three days but do not proceed with their development unless within that period they find their way into the interior of a small fresh-water crustacean—*Cyclops* (Fig. 94). According to the older accounts the young *Dracunculus* bores its way into the body of the *Cyclops* between the hard plates covering its abdomen. More recent observers state that it has to be swallowed by the *Cyclops*, and that within a period of from 6 to 24 hours it has bored its way through the wall of the alimentary canal and taken up its position in the blood-spaces (haemocoel) of the crustacean.

Within the body of the *Cyclops* various changes in detail take place and after about five weeks the larva is ready for transference to its mammalian host. This takes place apparently by the infected *Cyclops* being swallowed in drinking water.

The obvious precaution to take against infection with *Dracunculus* is to see that all drinking water is either filtered, heated, or otherwise treated, so as to destroy the *Cyclops*. Where the individual is already infected the superficial ulcer should be doused with cold water at intervals until—after 2 to 3 weeks—the uterus is completely emptied. The body of the worm may then slowly be drawn out by winding it round a stick, an inch or two at a time, or it may be killed *in situ* by injecting

into it a little corrosive sublimate solution. In the latter case the dead remains of the worm are gradually destroyed by the living activities of the surrounding tissue.

FILARIA BANCROFTI

This is a slender thread-like worm, the female about 100 mm. in length and the male about 40 mm. It occurs as a parasite of man in widely distributed localities throughout the Tropics and inhabits the lymphatic spaces. The young when born pass into the lymph and have a very characteristic appearance. They are about .3 mm. in length and each is enclosed in a loosely-fitting tubular membranous sheath closed at each end in which it lashes actively backwards and forwards. The sheath is simply the egg-shell which has entirely lost its rigid character and become quite soft. The young worms pass from the lymph into the blood in which there may be several millions present without producing any apparent ill-effects on the health of the host.

When the blood of an infected person is examined microscopically in the ordinary way—by taking a drop from the skin—the worms are found to present an extraordinary periodicity. During the day they may be completely absent. Towards sundown they begin to make their appearance and during the evening their numbers undergo a rapid increase, until between 10 and 12 o'clock the blood is swarming with them. Then they gradually decrease again in numbers until by 7 or 8 A.M. they have almost entirely disappeared.

This periodic appearance and disappearance of the worms was a great puzzle until Manson established the fact that during the hours of daylight they do not pass out of existence but merely frequent the deep vessels of the body, congregating in the great arteries and more especially in the lungs, in which organ they collect in the capillaries as well as in the larger vessels. The migration from these deeper vessels into the vessels of the skin turns out to be an adaptive arrangement, correlated with the fact that part of the life-history is passed in the body of night-flying mosquitos of various species.

When blood containing the young worms is taken in by a mosquito, the worms continue their active movements within the sheath. The sheath is now restrained in its movements by the viscid contents of the mosquito's alimentary canal and after a while the worm, butting against now one and now the other end of the sheath, breaks its way out of it. It soon (within six to twelve hours) bores through the wall of the alimentary canal and takes up its position amongst the muscles of the

thorax, its form becoming shorter and somewhat sausage-like. Here it remains for some time, growing to a length of about 1.6 mm., and then makes its way to the proboscis.

Although in many cases no ill effects upon the health of the host are apparent as a result of infection with *Filaria bancrofti* it is believed that this parasite is really the cause of those swellings of the lower parts of the body known in medicine as *Elephantiasis arabum*. This disease agrees closely in its geographical distribution with *Filaria bancrofti*: its direct cause appears to be obstruction of the flow of lymph and it is believed that this obstruction is due to the presence of the filaria. As regards the precise method by which the obstruction is brought about—it is believed by some to be due to inflammatory change in the lining of the lymph-spaces, brought on by the presence of the parasite, while by others it is attributed to actual blocking of the lymph stream either by groups of adult parasites or by their eggs. In exceptional cases the female lays eggs of which the shells have not become soft and extensible as happens normally, but have on the contrary remained hard and rigid. Whereas the natural slender larva in its soft membranous sheath readily passes through the narrow chinks of the lymphatic glands such abnormal eggs retaining their ellipsoidal form are liable, on account of their much greater diameter, to stick in the lymphatic gland and thus obstruct the lymph-flow (Manson).

FILARIA LOA

This parasite occurs in tropical West Africa (also Uganda), living preferably in the connective tissue under the skin, in which it creeps actively about. Sometimes it attracts particular attention by traversing the front of the eye-ball. The adult female measures about 45-60 mm. in length, the male about 25-30 mm. The young are born in a sheath formed by the softened egg-shell, as in the case of *F. bancrofti*, and they also find their way by lymph channels into the blood. They are about the same size as the young of *F. bancrofti* (about 250-300 μ in length) but may be distinguished by their shorter sheath and by the less regular curvature of the body. They are also at once distinguishable by their habits, for they migrate to the superficial vessels of the skin during the daytime, on which account they were formerly usually known under the name *F. diurna*, while the young of *F. bancrofti* were known as *F. nocturna*. This difference in habit is due to the fact that the transmitting insect is in this case not a night-flying mosquito but a biting fly of the genus *Chrysops* (Leiper) which is active by day.

FILARIA PERSTANS

This is a common parasite in Western Tropical Africa, the Congo, Uganda, Algeria, Tunis and in British Guiana, inhabiting the connective tissue, particularly in the mesentery and lining of the body-cavity. The female measures 70-80 mm. in length, the male about 45 mm. The young reach the blood as in the two preceding species but can at once be distinguished by their smaller size (200-230 μ) and by their being without a sheath. There is no periodicity in their appearance in the superficial blood-vessels, and this, as well as the lesser frequency of this parasite in natives who wear no clothes, suggests that possibly the transmitting insect in this case may be a louse or a flea (Christy).

STRONGYLOIDES

Female individuals of *S. stercoralis*—small worms slightly over 2 mm. in length—occur as parasites in the lining of the intestine of man in many of the warmer parts of the world. In some cases of intestinal trouble the parasites are apt to be particularly numerous though it is not believed that they are the actual cause of disease. The eggs, which apparently develop without being fertilized (**parthenogenesis**), give rise to minute larvae which make their way into the cavity of the intestine and after growing to about .75 mm. in length pass out to the exterior in faecal matter. If conditions are favourable (moisture and a temperature of 25°-35° C.) they develop into Rhabditis forms with separate sexes. The eggs from these develop into larvae which are at first Rhabditis-like but which gradually take on the form of the parasitic Strongyloides. If now they reach the intestine of man directly through the mouth, or possibly also as in *Ancylostoma* by boring through the skin, they develop into adult females like those from which the life-cycle started.

The combination of features that we find in the typical Nematodes—the thick cuticle, the absence of colour, the relatively inefficient movements, the absence of sense-organs, the simple alimentary canal, the large numbers of eggs—make it clear that they constitute a group which has been evolved as parasites. A survey of the group shows however that many of its members have emancipated themselves to a less or greater extent from simple parasitism within a single type of host.

I. Amongst the forms dealt with in this chapter *Trichina* remains

throughout its existence completely parasitic, passing from one individual host to another simply by bodily transference in the encysted condition.

II. In *Ascaris*, *Trichocephalus*, *Oxyuris*, the eggs pass to the exterior and lead for a time a free existence but they complete their development only if taken in by a second individual host.

III. In *Ancylostoma* not merely the egg stage, but the young worms themselves are for a time free-living, but a return to the host is necessary for them to complete their development. In *Dracunculus* a similar condition is found, with the additional complication however that the free stage makes its way into a second or intermediate host, of a species different from the principal host: while in *Filaria bancrofti*, *F. loa*, and *F. perstans*, the whole of the part of the life-history free from the principal host is passed within the body of the secondary host.

IV. In *Ascaris nigrovenosa*, a common parasite in the lung of the ordinary Frog, the young which pass to the exterior become sexually mature and one or more generations of free-living individuals occur before the return to the host. A somewhat similar life-history occurs in the human parasite *Strongyloides stercoralis*.

V. In *Anguillula* and its allies—small nematodes which occur commonly in soil, in flour-paste, in vinegar (exhibited sometimes by showmen under the microscope as “eels” in paste or vinegar)—the parasitic phase has become completely eliminated from the life-history.

BOOKS FOR FURTHER STUDY

Brumpt. Précis de Parasitologie.

Manson. Tropical Diseases.

Castellani and Chalmers. Manual of Tropical Medicine.

CHAPTER VI

ARTHROPODA

A. Terrestrial Arthropods breathing air by tracheal tubes.

I. PROTARTHROPODA—*Peripatus*.

II. MYRIAPODA—Centipedes, millipedes.

III. INSECTA—Insects.

1. Aptera (Primitively wingless insects)—*Machilis*, *Lepisma*.

2. Orthoptera—Cockroaches, Earwigs, Locusts, Grasshoppers, Praying Insects (*Mantis*), Stick- and Leaf-Insects (Phasmidae).

3. Hemiptera—Bugs, Green fly (*Aphis*).

4. Neuroptera—Dragon-flies, May-flies, Termites.

5. Coleoptera—Beetles.

6. Hymenoptera—Bees, Wasps, Ants, Ichneumon-flies.

7. Lepidoptera—Butterflies and Moths.

8. Diptera—Flies.

Aphaniptera—Fleas ; Anoplura—Lice ; Mallophaga—"Biting Lice."

B. Mainly terrestrial Arthropods possessing book-like breathing organs.

IV. ARACHNIDA—King-Crab (*Limulus*), Scorpions, Spiders, Mites, Ticks.

C. Aquatic Arthropods breathing by gills.

V. CRUSTACEA—Lobsters, Prawns, Shrimps, Crabs, Sand-hoppers, Slaters (Wood Lice).

The phylum Arthropoda includes, as will be gathered from an inspection of the foregoing table, an immense variety of creatures—the known species greatly exceeding in number those of all the other phyla put together. The beauty and variety of their colouring and form, and the

ease with which they can be preserved, make them special favourites of collectors, while many members of the group are of directly practical importance to mankind by providing food material, or by destroying crops and manufactured articles, or by causing bodily injury by bites or stings, or by acting as carriers of disease-producing microbes. In this book only the barest outline of the characters of the phylum will be attempted.

The general plan of structure of the Arthropod is a further development of that seen in the Annelid. Here again the body is metamerically segmented and the individual segment carries a pair of appendages: but these appendages are longer and more slender and in general much more highly evolved than the stump-like parapodia of the Annelid. Here again, in correlation with the mode of movement, the front end of the body is specialized to form a head: but the head has reached a far higher degree of complexity than that of the Annelid. The central nervous system with its ventral chain of ganglia and its supra-oesophageal ganglionic mass is clearly of the same type as that of the Annelid.

But the Arthropoda have diverged from the annelidan type of structure so as to develop peculiarities of their own. Two of these are of fundamental importance.

(1) The cuticle, which in the Annelid is thin and membranous except where it undergoes local thickening to form a chaeta, has in the Arthropod become greatly exaggerated to form an armour coating, composed of the nitrogen-containing substance **chitin**, covering the entire surface of the body and forming an admirable protection against the attacks of other organisms—including disease-producing microbes. We may probably take it that the development of this protective coat has been one of the chief factors—if not *the* chief factor—in enabling the Arthropods so successfully to hold their own in the struggle for existence. As will become apparent in the course of this chapter, the development of the rigid exoskeleton has also brought in its train important secondary results which find their expression in peculiarities of structure, function, or life-history.

(2) The other fundamental feature of arthropodan organization which calls for mention at this point is that the coelome has shrunk up to hardly recognizable vestiges, its place as body-cavity being taken by a loose spongework filled with blood and continuous with the cavity of the heart. This spongework represents the network of blood-vessels, which have lost their definite tubular form and become widened out into indefinite irregular spaces. Such a type of body-cavity—formed of

degenerate blood-vessels—is spoken of as a **haemocoelic** body-cavity¹ in contradistinction to the coelomic body-cavity such as is present in Annelids.

There remains to be mentioned a third—less fundamental but still very characteristic—feature of arthropodan structure, namely, that one or more pairs of the appendages in the neighbourhood of the mouth are modified as jaws or other organs connected with the act of feeding. This peculiarity, which no doubt found its commencement in evolution in the fact that these appendages, like other parts of the body, are ensheathed in hard exoskeleton well adapted for crushing the food, is so characteristic that a name expressing it—e.g. **GNATHOPODA**—would really be preferable to the more commonly used name for the phylum—**Arthropoda**.

As will have been gathered, the Arthropods appear to be descended

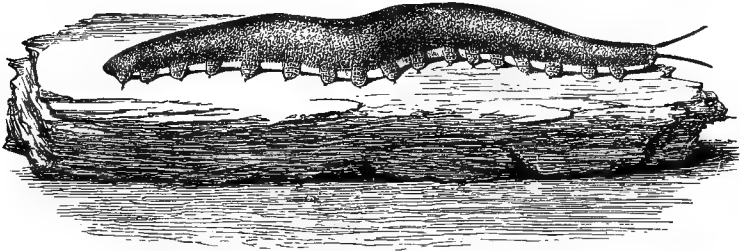

FIG. 95.

Peripatus (from Sedgwick: *Cambridge Natural History*).

from annelid-like ancestors: the primitive form of the body is in consequence elongated and worm-like, as may still be seen in *Peripatus* (Fig. 95), or in the Myriapoda, or in the larvae of various insects (Fig. 97, A). In the more highly developed types of arthropod, on the other hand, the body has become more compact and has also become differentiated into distinct regions. Thus in an insect one may recognize distinct **head**, **thorax** and **abdomen**, marked off from one another by more or less distinct constrictions, while in a typical crustacean, such as a Lobster or Crayfish (Fig. 102), one may similarly distinguish **cephalo-thorax** and abdomen. In the Arachnids there may be three main body-regions distinguishable—the **prosoma**, **mesosoma** and **metasoma**—as in the Scorpions (Fig. 99), or only two—prosoma and **opisthosoma**—as in the case of *Limulus* (Fig. 98) or of the spiders. In the Arachnida and

¹ From haemocoele—a term sometimes applied to the whole system of spaces in the animal body containing blood, i.e. the cavities of the blood-vessels.

the Crustacea the extreme hinder end of the body may be marked off from the rest as a **telson** (Figs. 98, 99, 102, *t*): in the Scorpion this forms the sting and encloses a poison gland which opens close to its tip—the whole constituting a hypodermic syringe for the injection of venom.

Some of the most characteristic features of the Arthropods are associated with the great development of the cuticle over the surface of the body. This has, as already mentioned, become greatly thickened while it has become hardened and stiffened by its conversion into chitin,¹ which in the case of the Crustacea is rendered still harder and more rigid by its becoming infiltrated by calcium carbonate.

This development of the cuticle would naturally tend to interfere with two of the most important vital activities of the animal—(I) movement and (II) growth, and some of the most striking secondary characteristics of the group have their functional significance in the eliminating or at least counteracting this interference.

I. The increase in hardness and thickness of the cuticle is not con-



FIG. 96.

Section through joint of an arthropod's exoskeleton.

tinuous over the whole surface. Along certain lines it remains thin and flexible, and these portions of cuticle are folded in below the general level (Fig. 96). The result of this arrangement is that the rigid armour is divided by joints at which the edges of the rigid portions can approach or recede from one another, and in this way flexibility is given to the whole and movement rendered possible. The degree to which this jointing of the exoskeleton is carried out is directly related to (1) the thickness and hardness of the exoskeleton and (2) the need for flexibility in the particular part of the body. Thus it is specially marked in the case of the limbs, and the jointed character of the limbs is regarded as so salient a characteristic of the phylum that it has been made use of in giving the group its technical name Arthropoda.

II. During the earlier part of an animal's life, as it progresses towards the adult condition, it as a rule undergoes (1) a gradual increase in size and (2) a gradual change of form. In the typical Arthropod both of these processes are interfered with by the presence of the rigid exoskeleton. Although, as in other groups, the amount of living substance in the body undergoes a gradual increase during the earlier stages of the life-

¹ See below, p. 216.

history, there is under normal conditions no possibility of increase in the volume of the body, ensheathed as it is in inextensible armour. And change of form is similarly impossible. These difficulties are met by the developing Arthropod undergoing periodical moults or **ecdyses**, at which it sheds its complete suit of cuticle. A new cuticle is developed underneath the old and this remains for a brief period soft and extensible, so that before it becomes hard and rigid the animal is able to undergo a rapid increase in bulk. The Arthropod therefore grows in a succession of spurts, one at each ecdysis, instead of by a continuous process.

So also with the change of form. At each ecdysis a slight change takes place and the sum of these comparatively slight changes makes up the, frequently great, total change in form from the young up to the adult condition.

METAMORPHOSIS

In some of the most highly evolved Arthropods—e.g. those included in certain orders of Insects—there has come about an interesting further development, in that the two processes—increase in size and change in form—instead of keeping step with one another have become concentrated in different parts of the life-history, practically the whole of the change in form taking place at the last two ecdyses, while the increase in size takes place in the preceding part of the life-history. In such cases the change in form at the last two moults is so striking in amount that it is given the special name **metamorphosis**.

An excellent example of metamorphosis is afforded by any ordinary Butterfly or Moth (Fig. 97). Here the earlier parts of the life-history are passed as a Caterpillar larva (Fig. 97, A), of elongated worm-like form, which feeds voraciously and grows actively¹ without showing any conspicuous change in form. On the completion of the penultimate moult, however, the creature is found to have undergone an extraordinary change in form, having become a resting **pupa** or chrysalis (Fig. 97, B). In this stage the creature is somewhat spindle-shaped: there are no legs or other appendages projecting beyond the general surface, although careful inspection reveals appendages plastered down to the body and absolutely immovable and useless: there is no mouth or anus. There is, in fact, no obvious sign of life except it may be an occasional slight bending of the body. After a more or less prolonged pupal period the last ecdysis takes place, and again an extraordinary change in form is to be seen—the creature becoming now an **imago** or

¹ The skin has reverted to the soft extensible condition like that of a worm, so that the growth of the caterpillar is no longer restricted to sudden spurts.

perfect insect (Fig. 97, C), fitted for active movement and provided with wings, legs, and other appendages.

Investigation of the details of internal structure of the insect shows

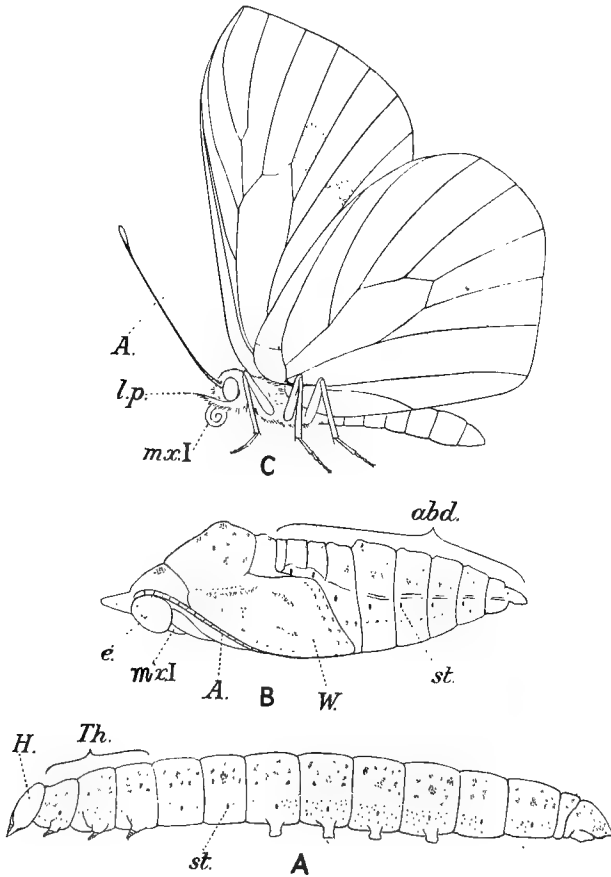

FIG. 97.

Life-history of a Cabbage Butterfly (*Pieris*). (From Graham Kerr's *Primer of Zoology*.) A, Larva (Caterpillar); B, pupa or chrysalis; C, Imago or adult. A, antenna; *abd.*, abdomen; *e*, radiate eye; *H*, head; *lp*, labial palp; *mx.I*, first maxilla; *st*, stigma; *Th*, thorax; *W*, wing.

that many of these undergo quite as profound an alteration during metamorphosis as does the external form.

It would appear to be a common feature of all animals except the simplest that there is constantly taking place during the period of active

life a certain amount of **cell-replacement**. Individual cells, or groups of cells, worn out by their activities become moribund, die, and are replaced by substitutes—cells which lag behind in their development and retain their juvenile characteristics until their services are needed, when they rapidly complete their development and take the place of their worn-out predecessors. A conspicuous example of this process has already been alluded to on p. 135—that of the yellow cells of *Lumbricus*, but it is probable that its occurrence, although in less conspicuous form, is a common characteristic of living tissues.

In the process of metamorphosis we have to do not merely with the concentration of change of bulk and change of form in a particular stage of the life-history but also with a similar concentration of this process of cell-replacement. The reinforcing cells are either scattered or in certain parts of the body form definite, easily recognizable patches, to which the old-fashioned name “imaginal discs” is still commonly given. Apart from the blood, the nervous, and the reproductive systems, the process of cell-replacement is to a great extent held back until the time of metamorphosis, when there sets in a process of wholesale disintegration of the tissues (**histolysis**)—their cells becoming moribund, dying, and disintegrating, and their remains being devoured by amoebocytes. At the same period the replacement cells burst into activity, multiply rapidly and undergo tissue specialization, until by the end of the pupal period they have provided a complete new outfit of tissues and organs, replacing those which have disintegrated and, it may be, differing greatly from them, in correlation with the changed functions which they will have to perform in the new life of the perfect insect.

It has been established in the case of some insects that the epidermis behaves in a different fashion at metamorphosis. In its case the cells do not die and become replaced by others: the cells of the larva appear to persist in the adult. This is apparently rendered possible by their possessing the power of recovering their juvenile activity by the extrusion from their inner ends of a quantity of chromatin which is at once ingested by amoebocytes. This process of **rejuvenation** of cells by the elimination of, presumably effete, chromatin is not at all understood: it appears to be of not infrequent occurrence in the animal kingdom, and it is probably the expression of a phenomenon of very deep biological significance.

Apart from the general effects which have been so far alluded to, the chitinous exoskeleton of the arthropod has definite functions of its own.

(1) It forms a magnificent protective envelope to the soft living protoplasm of the body, guarding it from mechanical violence, from

desiccation, from the effects of harmful substances, and from the attacks of other organisms.

(2) It serves as a skeleton in the ordinary sense, supporting the soft tissues and giving firm attachments for the muscles by which movements are carried out.

(3) Formed as it is of chitin—a compound of carbon, hydrogen, oxygen, and nitrogen—it constitutes so much waste, or excretory, nitrogenous material which, instead of being got rid of as soon as formed, is deposited in the cuticle and cast off periodically at the ecdyses. It thus plays an important part in the function of nitrogenous excretion.

• While the hard jointed exoskeleton is highly characteristic of the typical arthropod, yet under certain conditions it is liable to revert to a thin flexible condition. Thus in Hermit Crabs this has happened on the hinder, abdominal portion of the body, which is kept tucked snugly away in the shelter of a Gasteropod (p. 267) shell. Again, in arthropods which have assumed parasitic habits the same may happen over the whole surface of the body.

APPENDAGES

The limbs of the Arthropoda are primitively numerous, arranged in pairs, one to each segment of the body, and alike. But it has been a characteristic feature in the evolution of the phylum that the appendages towards the hinder end of the body have tended to become reduced and indeed to disappear entirely. Thus in the prawns and shrimps the abdomen possesses small but comparatively well developed appendages which are used for swimming: in the lobsters and crayfishes (Fig. 102, B) these have become further reduced in size: in male crabs—in which the abdomen is carried bent forwards beneath the cephalo-thorax—they have been reduced to the verge of disappearance, except the front two pairs, which have been preserved owing to their performing a sexual function. In the female crab the whole series has been preserved from reduction, in this case also owing to their having a sexual function—for the eggs are carried about cemented on to the bristles which project from these appendages.

In the tracheate division the same tendency is seen. In *Peripatus* (Fig. 95), or in a Myriapod, the series of appendages extends without any reduction in size to the hinder end. In the most primitive insects—such as the “Silver fish” (*Lepisma*), sometimes imported with sugar boxes, or the little *Machilis*—which may often be seen running about

actively on rocks and walls near the sea—the abdominal appendages are reduced to small simple vestiges. In the embryo of the higher insects the same vestiges may be seen, but in the adult they have disappeared completely so that the abdomen is limbless.

In the Arachnida we find the same tendency, although some of the abdominal appendages may persist in the Spiders in the form of little finger-like organs for the manipulation of the threads of the web, or, as will be shown later, in the form of special breathing organs.

The persisting appendages show in each of the three main subdivisions of the Arthropoda modifications in relation to differences in function which afford extraordinarily interesting studies in morphology.¹ We will sketch these modifications in outline, keeping the three subdivisions separate and so avoiding the comparison—which the present writer believes to be fallacious—of the individual appendages, and still more of parts of appendages, in one group with those in another. While avoiding such comparisons in detail, it is important to bear in mind that all three groups present the common feature already alluded to, that the jaws used for masticating the food are modified appendages.

APPENDAGES OF THE ARACHNIDA

Within this group the series of appendages is seen in its least modified form in *Limulus* (Fig. 98, B). The first pair of appendages, the **chelicerae** (I), are small nippers placed just in front of the mouth. The nipper at the end of the appendage is formed by the penultimate segment being prolonged into a kind of prong alongside the terminal segment. The terminal segment can be pressed strongly against this prong so as to take a tight grip of any object between them. A nipper constructed in this fashion is known technically as a **chela**, and a limb possessing it is described as **chelate**. The next five limbs on each side (Fig. 98, B, II-VI) are large walking legs. In the female these are all chelate except the last: in the male, however, II is without a chela and ends in a stout swollen claw. VI is provided near its tip, in both sexes, with a number of flat plates which the king-crab uses in burrowing into the sand.

These appendages (II-VI) are arranged round the sides of the mouth.

¹ The word **morphology**—invented (1807) by Goethe, poet and naturalist—is used to designate the philosophical side of anatomy. Anatomy deals with the “unmitigated facts” of structure: it becomes morphology as soon as the attempt is made to correlate these facts of structure with underlying principles—such as, above all, evolutionary history.

The basal segment of each is enlarged to form a stout blade with stiff spikes or bristles projecting from it. This blade-like development is known as a **gnathobase**, and the development of a gnathobase is one of

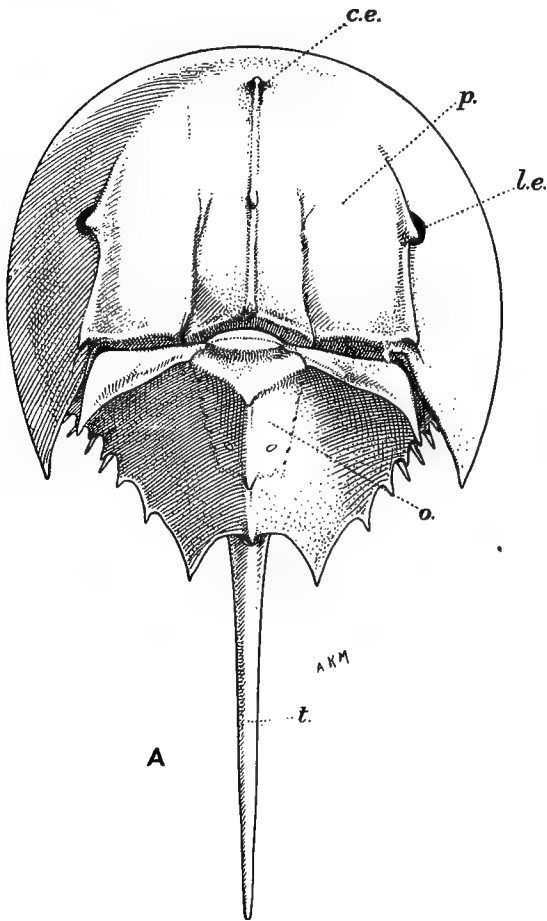

FIG. 98.

A King-crab (*Limulus*), female. A, dorsal view. *c.e.*, Central eye; *l.e.*, lateral eye; *o.*, opisthosoma; *p.*, prosoma; *t.*, telson.

the most characteristic of the modifications of the arthropod limb for purposes of mastication. The seventh appendages (Fig. 98, B, VII) are a pair of stout rod-like organs called **chilaria**, just behind the mouth. The eighth appendages (VIII) are flattened plates, continuous with one

another across the mesial plane and forming the **genital operculum**, the genital openings being situated on their posterior face. Appendages IX-XIII are also plate-like structures very much like the genital oper-

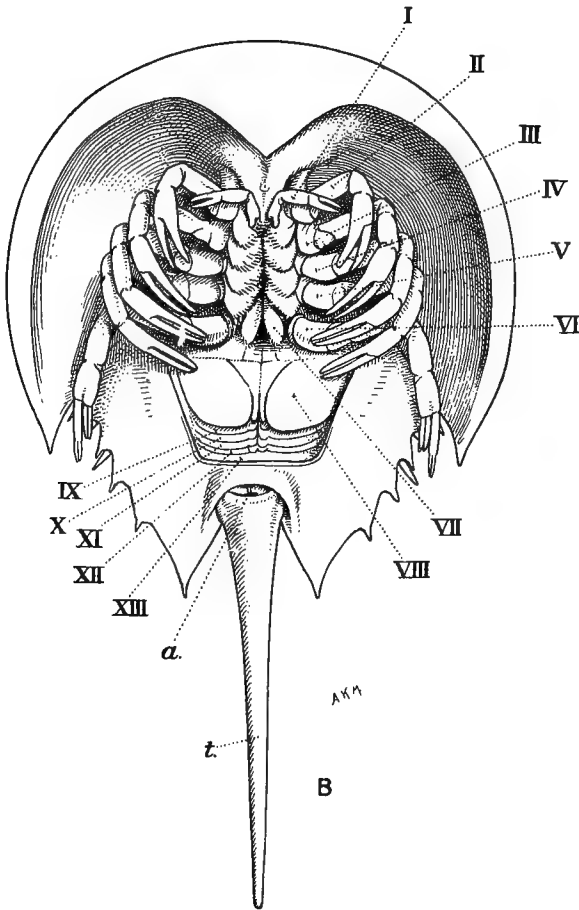

FIG. 98.

A King-crab (*Limulus*), female. B, ventral view. I, Chelicera; II-VI, walking legs; VII, chilarium; VIII, genital operculum; IX-XIII, respiratory appendages; *a*, anus; *t*, telson..

culum, differing from it, however, in that each carries on its posterior surface an arrangement of thin flat plates, lying over one another like the leaves of a book (Fig. 101, A). These **gill-books** are the breathing organs of the *Limulus*, each leaf containing blood and possessing a very

thin chitinous wall which allows ready respiratory exchange of gas between the blood within and the sea-water without.

The SCORPIONS are Arachnids which have forsaken the sea and taken to a terrestrial existence, and their appendages, while agreeing exactly

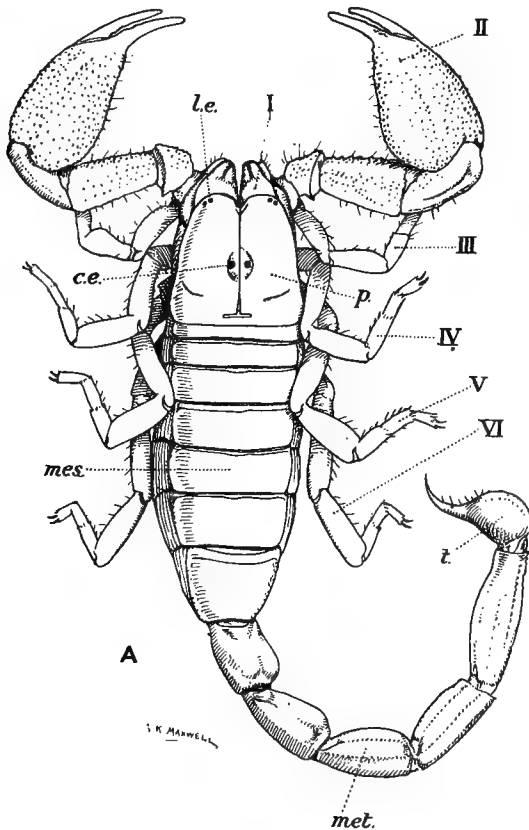

FIG. 99.

A Scorpion. A, dorsal view. *c.e.*, Central eyes; *l.e.*, lateral eyes; *mes.*, mesosoma; *met.*, metasoma; *p.*, prosoma; *t.*, telson. I, Chelicera; II, pedipalp; III-VI, walking legs.

as a series with those of *Limulus*, show interesting modifications in detail (Fig. 99). The first appendages (I), as in *Limulus*, are small chelicerae, and the next five (II-VI) are walking legs. These are more slender than those of *Limulus* and, excepting II (**pedipalp**), which is stout and chelate, possess a sharply clawed foot. The pedipalps are of special

interest as showing the very first beginning of the modification of an appendage for purposes of mastication—the basal segments (Fig. 100, II) being especially stout and strong, being attached to the body in close proximity to one another, and being movable in such a way as to be squeezed together and crush any food substance between them. The

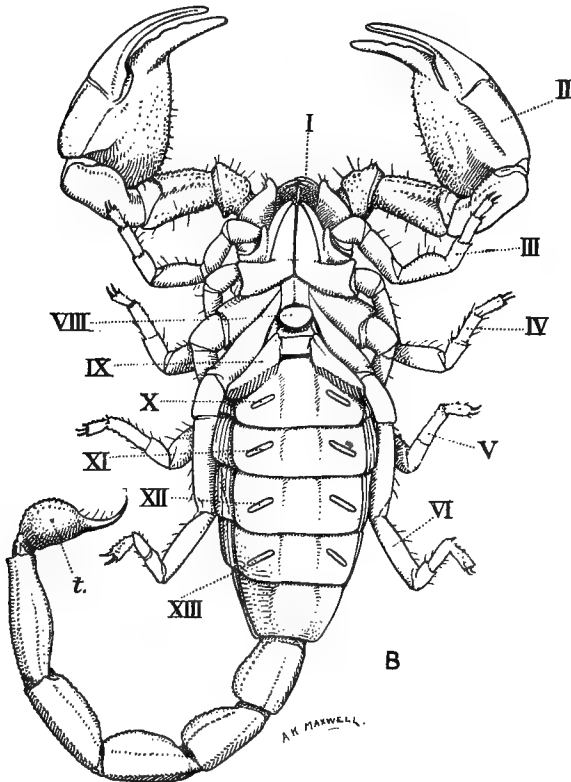

FIG. 99.

A Scorpion. B, ventral view. I, Chelicera; II, pedipalp; III-VI, walking legs; (VII, missing in adult); VIII, genital operculum; IX, pecten; X-XIII, openings of lungs. *t*, Telson.

succeeding two pairs of appendages (III and IV) are also adapted for mastication, but here the specialization has gone a step further, the basal segment of each projecting forwards as a stout blade, with a cutting edge on its mesial side, which can be brought against its neighbour like the blade of a pair of bone forceps. The seventh appendages, corresponding to the chilaria of *Limulus*, are completely absent in the adult, but it is

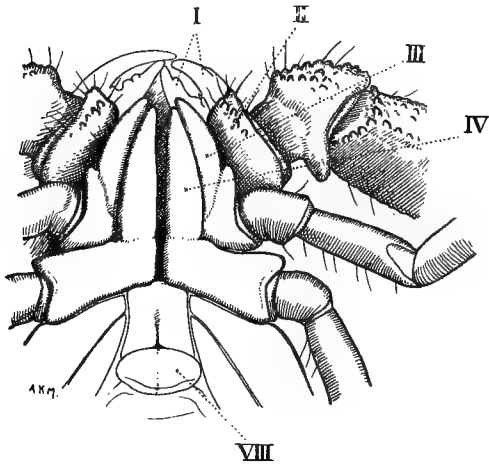

FIG. 100.

Scorpion—enlarged view of the bases of appendages II–IV. The reference line points in II, III and IV to the basal segment modified for crushing and cutting the food.

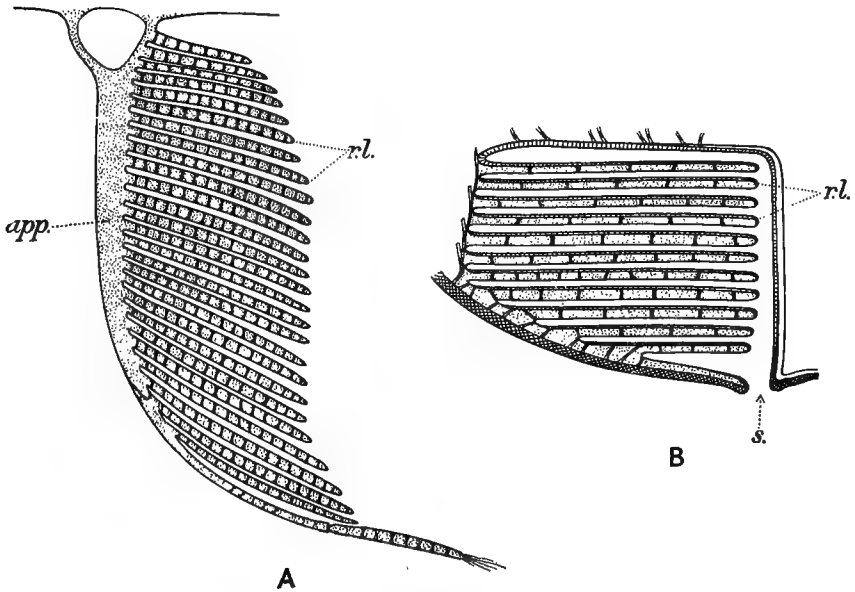

FIG. 101.

Longitudinal section through breathing organ of (A) *Limulus* ; (B) Scorpion.
app., Appendage ; *r.l.*, respiratory lamellae ; *s.*, stigma.

interesting to note that in the young embryo they duly make their appearance as small rudiments although they fail to proceed with their development. The eighth appendages form a genital operculum (Fig. 99, B, VIII) as in *Limulus*, only greatly reduced in size. The ninth appendages are curious comb-like organs (**pectines**—Fig. 99, B, IX) the function of which is unknown. Appendages X-XIII appear to be completely absent in the adult, and in about the position where each of them should be there is present a narrow somewhat obliquely-placed slit (**stigma**—Fig. 99, B, X-XIII) which leads into one of the breathing organs or **lungs**. Each lung is a small chamber into the cavity of which there project backwards from its anterior wall an arrangement of thin leaves (**lung-book**) like those of the gill-book of *Limulus* (Fig. 101, B). A fascinating light is thrown on the evolutionary history of these lungs by the study of their mode of development in the young Scorpion embryo, for it is found that in place of each lung there exists for a time a definite limb rudiment, which develops projecting plates on its posterior surface, agreeing exactly with the rudiments of the gill-book in the young *Limulus*. In the Scorpion however as development goes on the limb rudiment with its gill-book ceases to project and becomes flush with the neighbouring surface, while the leaves project into a depression of the surface, which gradually deepens to form the lung cavity.

APPENDAGES OF CRUSTACEA

To illustrate the series of appendages of the Crustacea we may take those of the Fresh-water Crayfish (*Astacus*).¹ The appendage is seen in its least modified form about the middle of the abdomen, say the third or fourth of the six abdominal segments (Fig. 102, B). Shaped like an inverted Y, it consists of a basal portion the **protopodite**, which bears at its end two diverging branches, an outer, the **exopodite**, and an inner, the **endopodite**, each tapering to a point and divided up into numerous segments. At each end of the abdomen the appendages are modified: at the hinder end the last of the series, while showing the same three parts as the typical appendage, has these parts broadened out into **flat** plates which when spread out in the same plane as the flat plate-like telson (Fig. 102, A, *t*) form with it an expanded kind of fin, the possession of which enables the animal to shoot rapidly backwards in the water by violently bending its abdomen in a ventral direction. At the front end

¹ Failing specimens of this animal the common Lobster (*Homarus*) or the Norway Lobster (*Nephrops*) may be studied: they agree with *Astacus* in all their main features.

of the abdomen the first two pairs of abdominal appendages (Fig. 102, B, a_1 and a_2) are, as already mentioned, modified in the male for sexual purposes, while in the female they are so reduced in size as to have almost disappeared.

In the region in front of the abdomen the appendages are stout 7-jointed

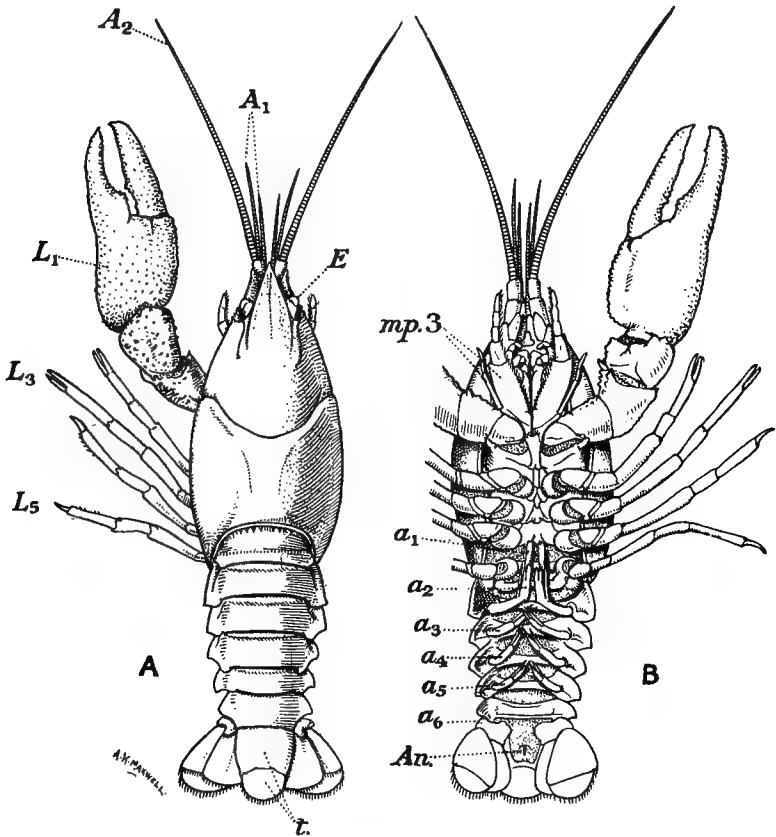

FIG. 102.

Dorsal (A) and ventral (B) views of a male Crayfish. A_1 , First antenna (antennule); A_2 , second antenna; a_1 - a_6 , abdominal appendages; An , anus; E , eye; L_1 - L_5 , walking legs; $mp.3$, third maxilliped; t , telson.

walking legs—five pairs. In the young Norway Lobster, which is a free-swimming larva, these appendages show the same three component parts as the abdominal appendage, but as development goes on the exopodite disappears, the walking leg of the adult consisting entirely of

protopodite (2 segments) and endopodite (5 segments). The larger basal segment of the protopodite carries attached to its outer surface (1) a flattened plate, the **epipodite** (Fig. 103, *L4*, *ep*), prolonged into numerous slender processes which constitute a breathing organ or gill, and (2) a tuft of fine chitinous threads (*t*). The three front pairs of walking legs differ from that which has been described in the fact that they are chelate, and in the case of the front pair (**chelipeds**) the chela is much enlarged (Fig. 102, *A*, *L1*).

The series of appendages in front of the chelipeds and extending to the level of the mouth is constituted by six pairs—the third **maxillipeds** (Fig. 103, *Mp.3*), the second maxillipeds (*Mp.2*), the first maxillipeds (*Mp.1*), the second **maxillae** (*Mx.2*), the **maxillulae** or first maxillae (*Mx.1*), and the **mandibles** (*M*)—characterized by loss of the primitive locomotor function of the limb and specialization in connexion with the act of feeding, specialization which reaches its height in the appendages nearest to the mouth. Thus the endopodite and exopodite are reduced in varying degrees as will be seen in Fig. 103.

In the case of the first maxilliped and the two pairs of maxillae, flattened plate-like gnathobases have grown out from the inner side of the protopodite, and in the mandible the limb has come to

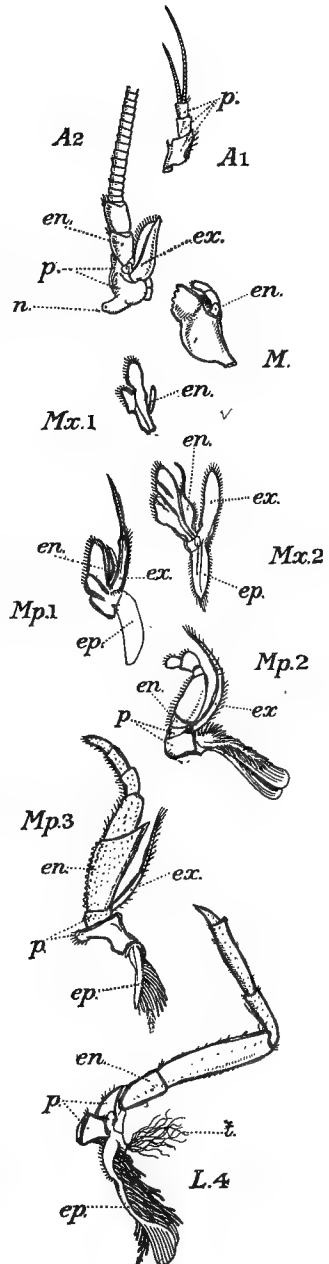

FIG. 103.

Appendages of Crayfish as seen from the ventral side. *A1*, First antenna; *A2*, second antenna; *en.*, endopodite; *ep.*, epipodite; *ex.*, exopodite; *L4*, fourth walking leg; *M*, mandible; *Mp.1*, first maxilliped; *Mp.2*, second maxilliped; *Mp.3*, third maxilliped; *Mx.1*, first maxilla; *Mx.2*, second maxilla; *n.*, external opening of nephridium; *p.*, protopodite; *t.*, chitinous threads.

consist almost entirely of a massive gnathobase, the rest of the limb being represented by a small 3-jointed endopodite (Fig. 103, *M*, *en*) which acts as a palp or sensory organ. In the appendages anterior to the second maxilliped the gills have disappeared, but the plate-like epipodite is still present on the first maxilliped and the second maxilla. In the latter the epipodite is continuous with the exopodite which is also plate-like in character, the two together constituting what is known as the **scaphognathite** (Fig. 103, *Mx.2*, *ep.* + *ex*).

The scaphognathite performs an important function in respiration. It lies in the front portion of a chamber into which project the gills, covered in and protected by a flap-like downgrowth of the dorsal body-wall—the **branchiostegite** or gill-cover. During life the scaphognathite performs rhythmic movements of such a kind as to draw a current forwards through the chamber so that the water bathing the respiratory surface of the gill undergoes constant renewal.

In front of the mouth lie two pairs of **antennae**. These are prolonged into one (second antenna) or two (first antenna or antennule) long, tapering, many-jointed filaments which are crowded with sensory cells and clearly function as organs of sense. They naturally recall to memory the sensory tentacles borne by the prestomium of the annelid, but the study of their development shows that they are quite different in their nature. The antennae of arthropods are true appendages which have become shifted forwards, so as to lie in front of the mouth, and taken on a purely sensory function.

APPENDAGES OF INSECTA

As has already been remarked, the insects are normally without appendages on the abdomen. In the thoracic region there are present three pairs of highly developed walking legs each terminating in a foot or tarsus consisting of a number (5 or less) of small segments, the terminal one carrying a pair of claws. Between the claws there may be present a cushion-like pad, the surface of which produces a sticky secretion enabling the insect to creep on smooth vertical or inverted surfaces.

The appendages in the neighbourhood of the mouth are modified in connexion with the act of feeding and—in correlation with the great differences between different types of insects in the nature of their food and the manner of feeding—great differences exist between the mouth appendages of different insects. Thus in the Bees the mouth-appendages are adapted for collecting pollen and nectar from flowers; in the Mosquitos

they form a miniature case of surgical instruments for piercing the skin and obtaining a supply of blood; in the Butterflies and Moths they form a long tubular siphon which can be lowered into the depths of deep flower corollas to suck up the nectar from their inmost recesses. And yet a careful comparison of these various types of feeding equipment show them to be composed of the same elements, the same series of appendages, modified to varying extents in size and form so as efficiently to perform their particular type of function.

A relatively unspecialized set of insect mouth appendages is to be found in the group Orthoptera, of which the Cockroach or "Black

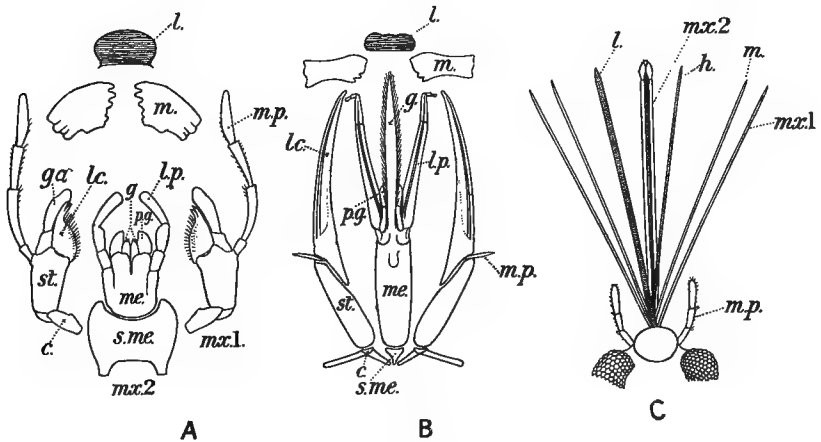

FIG. 104.

Mouth appendages of three different types of Insect. A, Cockroach (*Periplaneta*); B, Bumble-Bee (*Bombus*); C, female Mosquito (*Culex*). *c*, Cardio; *g*, glossae or ligula; *ga*, galea; *h*, hypopharynx; *l*, labrum; *lc*, lacinia; *lp*, labial palp; *m*, mandible; *m.p*, maxillary palp; *me*, mentum; *mx.1*, first maxilla; *mx.2*, second maxillae (labium); *p.g*, paraglossa; *s.me*, submentum; *st*, stipes.

Beetle" is an example (Fig. 104, A). There are here three pairs of such appendages—the mandibles (*m*), the first maxillae (*mx.1*) and the second maxillae (*mx.2*). Of these the mandible is simply a gnathobase, ensheathed in very dense chitin with a sharp serrated inner edge: there is no palp on the mandible in insects. The first maxilla is much more complicated: its basal joint (cardo—*c*) carries an elongated piece (stipes—*st*) and this in turn bears at its end two lobes, an inner, claw-like and with stiff bristles—the lacinia (*lc*), and an outer, soft and cushion-like—the galea (*ga*). This appendage is provided on its outer side with a jointed sensory **maxillary palp** (*m.p*). The second maxillae can be seen to be composed of the same set of elements as the first

maxillae, but here the two appendages have undergone fusion across the mesial plane to form the **labium**. The two cardines are completely fused to form the submentum (*s.me*). The two stipites have fused except just at their tips to form the mentum (*me*) and each of them carries its inner and outer lobe—here called respectively glossa (*g*) and paraglossa (*pg*). On each side of the labium is a small **labial palp** (*l.p*). In addition to the foregoing portions, which can be readily correlated with corresponding portions of the first maxillae, there is present a conspicuous soft tongue-like **lingua** (sometimes called hypopharynx) which springs from the base of the labium on its anterior side, just behind the slit-like mouth opening.

Finally there is present the **labrum** (*l*)—a plate-like flap of exoskeleton hanging down in front of the mouth and differing in nature from the mouth parts hitherto described in that it has nothing to do with the true appendages.

An examination of the mouth parts of one of the bees, such as a common bumble-bee (*Bombus*—Fig. 104, B) shows that here again is the same set of mouth parts. The chief differences are in the maxillae. In the second maxillae or labium the glossae are fused together to form a long tongue—the **ligula** (*g*)—used for licking up the pollen and traversed along its hinder surface by a deep groove, nearly converted into a tube by its edges meeting, up which nectar is sucked. The paraglossae (*pg*) are reduced but the labial palps (*l.p*) have their two basal joints much elongated and hollowed out along their median surface into a deep groove. When the two palps are approximated together the soft and delicate ligula lies safely protected in these grooves. In the first maxilla the lacinia (*lc*)—shaped like the blade of a scythe—is the most conspicuous part, while a small maxillary palp (*m.p*) is also recognizable.

In the Mosquitos the females—which alone suck blood—possess the array of mouth appendages shown in Fig. 104, C. The labium (*mx.2*) is elongated and is given a trough-like form by a wide and deep groove which traverses its anterior surface and serves to contain and protect six delicate piercing stylets. Of these four represent the two mandibles (*m*) and the two first maxillae (*mx.1*).¹ The remaining two are the unpaired labrum (*l*) and hypopharynx (*h*). Of these the former is provided with a deep, nearly closed-in, groove along its hinder surface so that it forms practically a tube up which the blood is sucked.

When not in use these piercing organs lie within the groove of the labium. When the mosquito bites the end of the labium is pressed against the skin and it becomes bent upon itself, while the stiff stylets,

¹ A maxillary palp is present (*m.p*) which in the females of some genera, such as that figured, is much shorter than in others.

remaining straight, pass onwards into the skin guided between two finger-like lobes (labella) at the end of the labium.

In the male mosquito the mandibles have disappeared and the hypopharynx has become fused with the labium.

In the House-fly (*Musca*) and its allies, which belong to the same order (Diptera) as the mosquitos, the mouth-parts are adapted entirely for sucking. Mandibles and first maxillae (except the palp) have entirely disappeared, while the labium forms a large conspicuous proboscis, the surface of its broadened-out end (labella) traversed by a system of deep channels by which fluid is drawn in to the mouth when the proboscis is moved, after the manner of a vacuum cleaner, over a surface on which soluble food matter is present.

In the Butterfly or Moth the mouth-appendages are practically reduced to the labial palps—conspicuous hairy-looking organs (Fig. 97, C, *l.p.*)—and the first maxillae (*mx.I.*). The latter are greatly elongated and are deeply grooved along their mesial surface, so that when fitted together they form a long tubular siphon. When at rest this is coiled up in a spiral under the insect's head, as shown in Fig. 97, C, but it can be uncoiled and lowered into the recesses of a deep tubular flower corolla.

In the Insects there is only a single pair of antennae.

WINGS

In the Insects, and in them alone among the Arthropoda, there occur normally in the adult stage **wings**. Of these there are usually two pairs, attached to the hinder two of the three segments which make up the thorax. These wings have nothing to do with the series of true appendages: they are flaps of skin rendered stiff by the two layers of stiff cuticle on their upper and lower surfaces, except at their base where the cuticle remains flexible so as to admit of free up and down movements. The two layers of the wing are in close contact except along a branched system of **nervures** along which blood-spaces and tracheal tubes (see below, p. 232) are interposed between the two layers. The arrangement of the nervures of the wing is very constant within the limits of particular groups, e.g. families or genera, while on the other hand characteristic differences occur between different groups. Consequently the neuriation of the wings is made much use of by entomologists in classifying insects.

The wings show characteristic differences in their general appearance

in the various orders or main subdivisions of the insects. In the Dragon-flies, May-flies, Termites and other insects commonly grouped together as Neuroptera the two pairs of wings are membranous and much alike. In the Hymenoptera (Bees, Wasps, Ants) both pairs of wings are again membranous, but the hinder wings are smaller and are attached to the fore-wings by numerous little hooks which project from the front edge of the hind-wing and hook over the hind edge of the fore-wing. Fore- and hind-wing on each side thus act as if they were a single continuous structure. In the Diptera (ordinary flies, Mosquitos, Midges) the fore-wings are membranous while the hind-wings are converted into curious club-shaped organs of unknown function called **halteres**.

In the Lepidoptera (Butterflies and Moths) the numerous little bristles scattered over the surface of the wing have taken the form of overlapping scales to which the colours of the wings are due. In the Orthoptera (Cockroach, Locust, Grasshopper, Earwig) the front wings have lost their function in connexion with flight: they have become thick and horny and serve as wing-covers to protect the delicate membranous hind-wings when these are not in use. In the Hemiptera the two pairs of wings may be thin and membranous (*Aphis*—Green fly) but more usually the fore-wings are thickened and protective as in the Orthoptera, only in this case the thickening of the wing is often more conspicuous in its basal portion (many Bugs). The protective modification of the fore-wings finds its greatest development in the Coleoptera or Beetles where they are greatly thickened and are known as **elytra**.

Wings are thoroughly characteristic of the group of Insects. Among those which are without them we have to distinguish between those in which the loss of wings is probably to be regarded as a secondary development—such as insects inhabiting small islands in the ocean and insects that have adopted a parasitic mode of life—and those which probably represent a primitive wingless stage of insect evolution (Aptera: such as *Lepisma* and *Machilis*).

The wings of insects arise in the embryo as flat flaps of skin which may grow out from the surface but much more frequently arise in the recesses of deep pockets of the skin, the "imaginal disc" corresponding to each wing having sunk deep below the surface. As regards their evolutionary origin we are still pretty much in the dark, but there is some reason to suspect that the extensions of the body-surface which now function as wings were primitively respiratory in function. In the aquatic larvae of certain insects (May-flies) there are present flat plate-like gills on the abdominal segments which present a striking resemblance in structure to wings and there is a tendency to revert to the view,

which was discredited for a time, that wings may have evolved out of such "tracheal gills" on the thoracic segments which have become more and more freely movable so as to function as organs of propulsion.

The alimentary canal of the Arthropoda is characterized by the tendency of the cuticle of the outer surface to be prolonged inwards as a protective lining. This is brought about by an ingrowth of ectoderm at the mouth end forming a stomodaeum and a similar ingrowth at the anal end forming a **proctodaeum**. It is a quite usual feature in animals for the tubular alimentary canal to have such an ectodermal section at each end. But in the Arthropoda these tend to be more highly developed than in other groups—stomodaeum and proctodaeum encroaching more and more, while the original endoderm-lined alimentary canal or **mesenteron** undergoes a corresponding shrinkage. This shrinkage is well exemplified by the case of the Crayfish or Lobster, where careless dissection commonly results in the alimentary canal breaking through the short mesenteric portion owing to this being devoid of the tough cuticular lining elsewhere present.

In the Insects there are usually "salivary" glands opening in the neighbourhood of the mouth. No doubt these originally fulfilled a function in connexion with the preparation of the food for digestion, but in special cases they have become specialized for other functions. Thus in blood-sucking insects the irritating secretion helps to promote the flow of blood to the wound. In the larvae of various insects the secretion is silk.

The haemocoelic character of the body-cavity has already been alluded to as a highly characteristic feature of the Arthropoda. It may be that the degeneration of the blood-vessels to form such a body-cavity arose in evolution in relation to a peculiar type of respiratory system—that found in the insects. In these arthropods the process of respiratory exchange with the external medium takes place through parts of the cuticle which have not undergone the thickening occurring elsewhere but have remained extremely thin. Wherever in the animal kingdom there are such portions of the surface specially devoted to respiratory exchange it is usual for the progress of evolution to bring about increase in the area of these respiratory surfaces. Most usually this increase is brought about by the surface sprouting out into more or less elaborately branched projections—the gills. In the insects the increase on the other hand has been brought about by growth of the surface not outwards but inwards. Each respiratory patch has come to dip down as a deep pocket into the interior of the body, and this pocket has had its lining enormously

increased by its developing into a complicated tree-like arrangement of branching tubes. These tubes or **tracheae** branch all through the body, their very fine terminal twigs ending blindly in immediate relation with the living protoplasm of the various tissues. Except in the case of the fine ultimate twigs the tracheae are kept open by a kind of spiral spring formed by a spirally running thickening of their cuticular lining.

In performing its breathing movements the insect compresses the contents of its body by muscular action. This compresses the tracheae, forcing the air in their interior out through the external openings or **stigmata** situated in a row along the sides of the body (Fig. 97, A, *st*). When the muscles relax, the spiral thickening of the tracheal lining causes the tracheae to resume their former volume and they are filled by an inrush of fresh air through the **stigmata**.

Whereas, therefore, in the Annelid worm the necessary supplies of oxygen are conveyed to, and the excreted carbon dioxide conveyed away from, the living tissues by the circulating blood, in the insect on the other hand the conveyance takes place in gaseous form in the tracheal tubes. In other words the tracheal tubes perform what is in the annelid one of the main functions of the blood-vessels, more especially of the capillary blood-vessels, and the suspicion is aroused that here may be the factor which has inaugurated the degeneration of the arthropodan capillaries and finer vessels. This idea goes against the commonly accepted belief that the arthropods were primitively aquatic animals, but it is supported by the fact that *Peripatus*—by far the most nearly primitive of the existing arthropods—is terrestrial and breathes by means of tracheae.

The spongy packing tissue between the spaces of the haemocoel is in the insects charged with droplets of fat which give it a snowy-white colour. This tissue is known as the “fatty body” of the insect. What its special function is, whether it fulfils a purely physical one in protecting the tissues from too great cooling by the constant indraught of air through the tracheae or on the other hand performs some more complicated rôle in metabolism, is not yet certainly determined.

In certain insects, such as the beetles known as fire-flies, particular localized masses of fatty-body are specialized as light-producing or photogenic organs. The light is apparently produced by the oxidation of a special substance formed in the metabolism of the organ. And in correlation with this the photogenic organs possess a very rich supply of tracheal tubes. The pale-greenish light most commonly produced is remarkable for its economical character, the proportion of the energy wasted as non-luminous rays being extraordinarily small as compared

with light produced by artificial means. The emission of the light appears to be under the control of the nervous system, there being probably some special mechanism for controlling the access of air to the light-producing cells. Physiologically the significance of these organs is connected with sexual attraction. In many cases the light is not a continuous glow but is emitted in long or short flashes: as is well known such an intermittent light is more efficient in attracting attention than is a steady glow. Further, the female sex is in some cases distinctly recognizable by the longer duration of the flash.

The sexual attraction of this naturally-produced light is merely a special case of the well-known "attraction towards light" shown by many insects. And this in turn rests on the fact that an insect in the presence of light proceeding from one localized source tends to assume an attitude in which its head is directed towards the source of light so that its two eyes receive the impression equally. To put it crudely and not quite accurately it "faces" towards the direction from which the light-impression comes. This tendency is well brought out in Fig. 105, a record made in tropical South America twenty-five years ago. The author sat at work in the evening by the light of a lamp on his left hand. Numerous homopterous insects alighted on the sheet of paper on the table in front of him. Each insect within a few seconds of its flopping down on the table rapidly adjusted its position and remained stationary with its long axis pointing towards the lamp, as indicated by the arrows of the diagram. It is obvious that an insect can fly only in the direction in which its head points: consequently if it adjusts itself during flight so that its head points towards the light it necessarily flies towards the light. As regards the insect's orientating itself towards the light there is in the author's opinion no scientific justification for excluding the action of psychical factors as is done by some physiologists.

The excretion of nitrogenous waste products is carried out in *Peripatus* by numerous pairs of nephridia. In the more typical arthropods the continuous series of nephridia is no longer present but the last survivors of the series are still distinctly recognizable in the Crustacea and the Arachnida. In the more lowly organized Crustacea they form what are known as the **shell glands**—opening at the base of the second maxilla—while in the more highly developed Crustacea such as the Crayfish, Lobster, or Crab, they form the **green glands**—opening at the base of the second antenna. In the Arachnida they form what are called **coxal glands** opening at the base of the fifth appendage. In the Insects they are no longer recognizable, there being here numerous blindly ending

excretory tubes (**Malpighian tubes**) opening into the alimentary canal near the front limit of the proctodaeum.

In connexion with the disappearance of the nephridial tubes during the evolution of the Arthropoda it should be remembered that in this phylum the function of excretion is carried out to a great extent by the skin, waste nitrogen being contained in the chitin which covers the

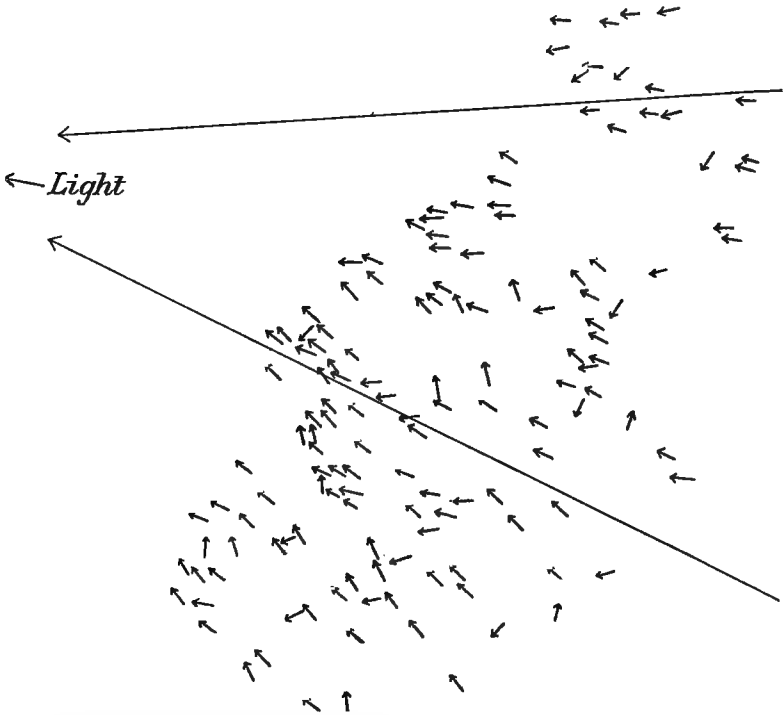

FIG. 105.

Record of the position of about 200 homopterous insects which alighted on a sheet of paper and then orientated themselves towards a lamp.

The thick arrows indicate the position of the long axes of the insects' bodies: the two fine lines indicate the direction of the source of light.

surface and is got rid of at each ecdysis. Furthermore the coloured pigments which are often present in the exoskeleton are excretory substances: for example, in the group to which our common Cabbage Butterflies (*Pieris*) belong the characteristic white pigment is impure uric acid, while the orange and yellow pigments are derivatives of uric acid. The Arthropod then has developed the habit of depositing its nitrogenous excretory material in insoluble form on the surface of its

body and shedding it periodically, instead of passing it off in solution by means of its nephridial tubes. It is probable that the development of this habit in the Arthropoda has had much to do with bringing about the reduction of the primitive nephridial tubes.

In the blood-system of the Arthropoda the most important feature is that already alluded to, namely that what would normally be the finer blood-vessels have become greatly dilated, forming a system of irregular spaces which constitute the haemocoelic body-cavity. The blood is driven through these spaces by the beating of the heart, which is here a development of the dorsal blood-vessel—extending it may be through a great part of the entire length of the body or being on the other hand shortened down into a compact organ.

Whatever be its shape the heart of the Arthropoda always shows this striking peculiarity that its walls are perforated by slits or *ostia* by which its cavity is in free communication with the body-cavity round it. The explanation of this peculiar circumstance lies of course in the fact that the body-cavity consists really of blood-spaces instead of being coelomic in its nature—and therefore isolated from the blood-system—as it is in most types of animal.

The blood is as a rule practically colourless but sometimes it is of a bluish colour owing to its containing in solution a bluish copper-containing substance Haemocyanin, possessing the same affinity for oxygen as Haemoglobin has (p. 141) and serving like the latter as a “vehicle” for oxygen.

The nervous system of the arthropod is constructed on the same general plan as that of the annelid. It has, however, reached a higher stage of evolution: the ganglion cells show a higher degree of concentration, the ganglia of the ventral cord being more distinct and in particular the supra-oesophageal ganglia or brain having reached a higher level of size and complexity of structure. This latter advance is correlated with (1) the great development of sense-organs in the head region; (2) the crowding together of the appendages and their associated nerve-centres around and in front of the mouth; and (3) the general tendency, apparent in the evolution of groups of animals which move actively with one definite end in front, for the control of the activities of the body as a whole to become more and more concentrated in the front portion of the central nervous system.

The fact that the general surface of the body consists not of soft living protoplasm but of hard chitin involves necessarily peculiarities in the sensory apparatus by which impressions are received from the outer world. Distributed more or less generally over the surface are **sensory**

bristles—fine hair-like projections of the cuticle ensheathing a prolongation of one or more underlying sensory cells. The function of these sensory bristles appears in many cases to resemble the sense of touch ; in other cases, more especially those of the antennules of Crustacea and the antennae of insects, they would appear to have to do with a sense which detects differences in chemical composition of the surrounding medium, like our senses of smell and taste ; but in all probability the actual kinds of sensation with which they are concerned are such as we can form no conception of, as they are not included within the limits of human sensory experience.

Just as is the case with the sensory cells of Coelenterates, so we find also in the Arthropoda the occasional occurrence of aggregations of these sensory bristles in special, more or less closed-in, depressions of the surface forming otocysts. An excellent example of the arthropodan otocyst is to be seen in the Decapoda (Lobsters, Crayfish, Prawns) where it is situated in the base of the first antenna, and forms a chamber which remains open to the exterior by a narrow slit guarded by bristles. From the floor of the chamber there project into its cavity a group of specially developed Γ -shaped sensory bristles, on the top of which rest a number of otoliths. In cases where the otocysts become completely closed the otoliths are secreted by the otocyst wall, but in the animals now under consideration where the otocyst remains open to the exterior the otoliths are grains of sand which the animal itself inserts into the cavity.

At each ecdysis the entire lining of the otocyst with the contained sand-grains is shed and consequently a new supply of otoliths has to be inserted before the organ can function. This has rendered possible a fascinating experiment to demonstrate the function of the otocyst. After ecdysis had taken place a prawn was provided not with ordinary sand but with fine iron filings—to which it duly helped itself. In ordinary circumstances the iron "otoliths," under the pull of gravity, served exactly as the ordinary grains of sand. When, however, a powerful electro-magnet in the immediate neighbourhood of the animal was brought into action, the result was the same as if the direction of gravity had been suddenly altered and the animal immediately heeled over, away from the direction of the magnet.

Of the sense organs of the Arthropoda the most interesting are the eyes which are normally present in the head region. An eye consists primarily, like any other sense organ, of an aggregation of sensory cells. These differ from the ordinary type of sensory cell in the fact that they are not provided with a sensory hair but have a portion of their cyto-

plasm highly specialized for carrying out the primary function of the eye, namely the conversion of light waves of the ether into living impulses. These specially modified portions of cytoplasm, characterized by their glassy transparency, are known as **rods**—from their shape in some of the better-known types of eye.

In the Arthropoda there exists great variety in details of eye structure, but amongst this variety there stand out two main types of structure (1) the simple or **camera** type of eye and (2) the “compound” or, better, **radiate** type.

The simple eye (Fig. 106, A) consists primarily of a biconvex thickening of the cuticle—the **lens** (*l*)—clear and transparent and serving to condense the light upon an underlying clump of sensory cells—the **retina** (*r*). The latter is usually displaced inwards, so as to be in the neighbourhood of the focus of the lens, by a mass of transparent cells constituting the **vitreous body** (*v*). When the eye has its retina displaced inwards in this fashion it no longer serves merely for the detection of light, and thus distinguishing between light and dark, but provides the means for producing a definite sensory picture of the external world.

The radiate eye is of a fundamentally different type—characterized above all by the fact that the retina is subdivided up into a number—it may be a vast number, many thousands—of **retinulae**, commonly arranged in radiating fashion owing to the fact that they are normal to the surface of the head and that this surface is strongly convex. Each retinula (Fig. 106, B) consists of a group or bundle of elongated sensory cells (*R*), the portion of cytoplasm of each cell next the axis of the bundle forming the rod (*r*) while the deep end of the cell is prolonged into a nerve fibre (*n.f*).

Between the outer ends of the retinulae and the cuticle with its underlying layer of cells is the vitreous body. This typically undergoes a subdivision similar to that of the retina, there being at the outer end of each retinula a **vitrella**, a group of (commonly 4) vitreous cells (*v*). The portions of these cells next the axis of the group are fused together and of a glassy transparency, constituting the **crystalline cone** (*c.c*).

Each vitrella is separated from its neighbours by cells (*p*) containing black or dark brown pigment. These together constitute a tubular channel through which the light rays reach the retinula—each retinula receiving its light only through the one of these tubes which is in line with itself.

In the more highly developed radiate eyes the cuticle covering its surface has undergone a subdivision corresponding with that of the underlying structures, the portion overlying each vitrella having become

convex outwards and, it may be, inwards as well. The cuticle is thus

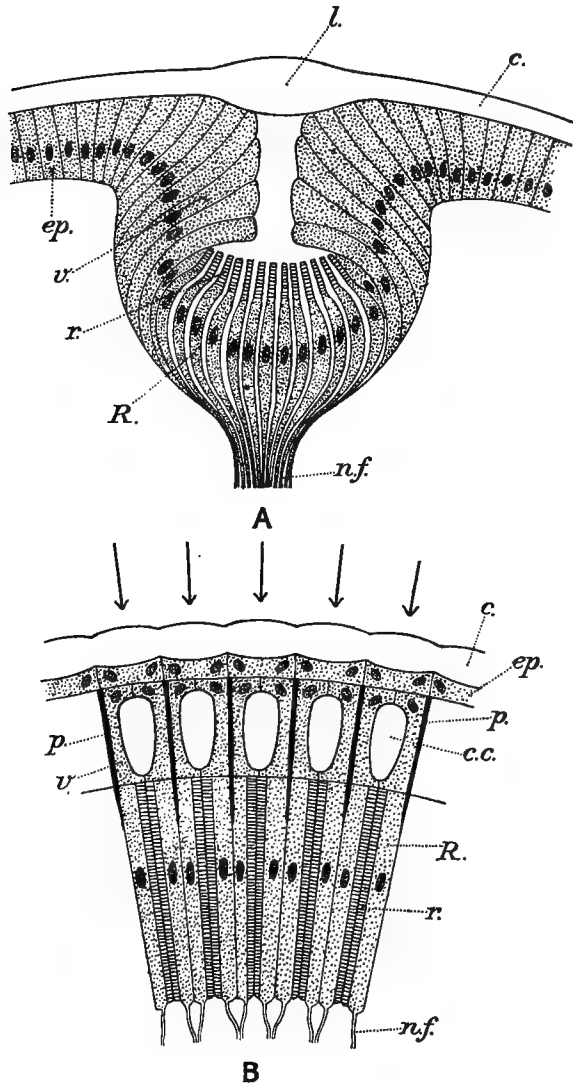

FIG. 106.

Illustrating the structure of the simple (A) and radiate (B) types of eye of the Arthropoda. *c*, Cuticle; *c.c.*, crystalline cone; *ep*, epidermis; *l*, lens; *n.f.*, nerve fibre; *p*, pigment-cell; *R*, retinal cell; *r*, rod; *v*, vitreous cell.

divided up into numerous little lenses the function of which apparently

is to ensure that the only rays that reach the individual retinula are those whose direction is approximately that of its own axis. All other rays, coming in at a considerable angle to this axis, are shunted off into the pigment cells and there absorbed.

It is clear that in this radiate type of eye we have to do with an organ that carries out the function of vision in a manner totally different from that of the more usual camera type of eye—where an image is formed, as in a photographic camera, by a lens and then cast upon a sensitive screen—the retina. The vision of the radiate eye is of what is called the mosaic type, there being formed not a continuous optical image but a collection of separate light impressions from the outer world, each coming in along the axis of a vitrella.

A definite mechanism exists for the weaving together of these separate impressions, for the group of nerve fibres which pass brainwards from each retinula separate from one another and then become collected into new groups, the fibres composing which, although the same in number as those of the original group, are derived not from a single retinula but from a group of neighbouring retinulae.

In spite of the existence of this mechanism for weaving together the isolated impressions into a continuous whole it is quite incredible that that impression can, as a representation of the outer world, be otherwise than exceedingly crude compared with that given by the camera eye. In all probability the special efficiency of the radiate eye lies not in forming a picture but in the detection of objects close at hand which are in motion relatively to the eye, either because the object is itself moving or because the arthropod is moving with regard to it. The same effect will be produced if the arthropod while remaining in one spot rotates its head—as a Dragon-fly may be seen to do when on the outlook for mosquitos.

ARTHROPODAN TYPES OF SPECIAL INTEREST

The main subdivisions of the phylum Arthropoda have been indicated on p. 209. While there is no necessity for the elementary student to go into the details of the classification of the group it is of importance that he should have a general idea of the features of special interest in connexion with various types of arthropod.

I. The group PROTARTHROPODA comprises the genus *Peripatus*—to the morphologist the most important of all arthropods, for it has lingered on until the present day as the sole representative of those annelid-like creatures that were gradually developing the characteristics of arthropods.

Peripatus (Fig. 95, p. 211) still retains the elongated worm-like form of body with simple stump-like appendages similar in character throughout the length of the body, the soft muscular body-wall without marked thickening of the cuticle, and the nephridia distributed in pairs segmentally throughout the length of the body. On the other hand it has developed the typical arthropodan characteristics that a pair of appendages have become converted into jaws and that the coelomic body-cavity has shrunk up and been replaced by a haemocoelic body-cavity filled with blood and in free communication with the interior of the heart by means of ostia. It possesses also the arthropodan character that it breathes by tracheal tubes. Further, although the number of segments in the body as indicated by the appendages differs in different species and even, to a less extent, in different individuals of the same species, this number remains fixed throughout the life of the individual from an early stage of embryonic development.

Peripatus is then on the balance of its structural features to be classed as an Arthropod. That it is a very primitive arthropod is shown—apart from the annelidan features already mentioned—by the relatively feeble elaboration of the head region. Only a single pair of appendages have become modified as jaws; there is none of that crowding together of appendages in the neighbourhood of the mouth and their modification for different functions that is so striking in the typical arthropod. Nor is there the correlated crowding together of the corresponding nerve-ganglia to form a complex brain.

Over fifty species of *Peripatus* are known, distributed in seven different centres in the warmer parts of the world (Mexico and West Indies to Rio; Congo; Malaya; South Africa; New Britain; Australasia; Chile). Such wide discontinuous geographical distribution is a feature commonly met with in ancient types of animal.

Peripatus lives in damp localities and during the day is to be found lurking under logs, bark or stones. It may be recognized by its general shape, its velvety skin, and its habit of ejecting sticky slime from the ends of the appendages next behind the jaws.

II. Under the name MYRIAPODA are included a number of groups of terrestrial arthropods which still retain the elongated form of body without differentiation into distinct regions but which in other respects are highly developed arthropods. They are exemplified by the carnivorous Centipedes and the vegetarian Millipedes. The former possess poison glands opening at the tip of the fourth pair of mouth appendages which have the form of claw-like poison-fangs. In the case of the large tropical centipedes the bite may be dangerous to man.

III. The INSECTA represent the highest stage of arthropod evolution. In fact as regards the high degree of evolution both of physical structure and of psychical development, which finds its expression in intelligence and in complexity of social organization, certain of the insects rank with certain of the vertebrates as the most highly evolved animals at present existing. The most nearly primitive members of the group are classed together as the Aptera, which have not yet developed wings, and which appear to possess, in some cases, vestiges¹ of appendages upon the segments of the abdomen.

The ORTHOPTERA include a large variety of well-known insects as may be gathered from the table on p. 209. They constitute one of the less highly evolved orders of insects: their mouth appendages are of the comparatively undifferentiated type seen in the Cockroach (p. 227): they do not undergo metamorphosis, the change in form from young to adult taking place in a series of small steps corresponding with the ecdyses. Some of them, such as Cockroaches ("Black Beetles"), Earwigs, and the migratory grasshoppers commonly called "Locusts," are of economic importance from the damage they do. Others, such as many of the true Locusts, Praying Insects, and Stick- and Leaf-insects, are of special scientific interest from the beautiful protective resemblance which they show in form and colour to such natural objects as leaves or sticks which form their normal background.

The HEMIPTERA, or Rhynchota, are easily recognizable by the fact that the labium forms a long, usually jointed, proboscis which when not in use is folded back beneath the thorax. As in the blood-sucking Diptera the labium is traversed on its anterior side by a deep groove which serves to contain and protect the sharp piercing stylets formed by the mandibles and the first maxillae. The group includes two sections which differ in the character of the wings. In the subdivision Homoptera the two pairs of wings are as a rule alike. They include the Cicadas, perhaps the noisiest of insects, in which in the males a special area of exoskeleton on each side of the hinder part of the thorax can be thrown into rapid vibration by muscular contraction so as to produce a characteristic sound, in some species like the whistle of a railway engine. The Greenflies or Aphides, including *Phylloxera*, a North American aphid which

¹ It is of advantage to be precise in the manner of using the two words rudiment and vestige. The two terms agree in that each means a small-sized representative of an organ. The difference is that the first is used for an organ on the up-grade of evolution, the second for one on the down-grade. Thus the representative of the wing in the embryo of a bird is a rudiment: the reduced remnant of the wing in a running bird, such as a Kiwi, is a vestige.

introduced into France caused immense destruction to vines, and the Coccidae or Scale-insects also belong to this group. In the Coccidae special secretions are commonly produced by the skin of the adult female: white wax, shellac, cochineal, are examples of such secretions of economic value. In the second section of the Hemiptera—the Heteroptera—in which the fore-wings are protective, are included a large number of insects which normally suck the juices of plants but which in some cases have developed the blood-sucking habit. The bed-bug (*Cimex* or *Acanthia*) with a very thin flattened body of a brownish colour and the Benchucas of South America (*Conorhinus*) are bugs which are important to man both by their unpleasantness and by the fact that they play a part in spreading protozoan microbes (pp. 49, 50). From the form of their body they are able to hide in very narrow crevices in walls and furniture and are consequently difficult to eradicate. Thorough fumigation or “gassing” is the most effective means of dealing with badly infested houses.

The group NEUROPTERA, which is now usually broken up into a number of independent groups but is retained here for the sake of simplicity, includes a large number of insects with biting mouth-parts and with two pairs of similar membranous wings, the nervures of which usually form a network of small meshes.

The Termites are well known from the fact that they commonly live in immense communities with highly complex social organization and marvellous differentiations of the individuals for different functions in the community. The most remarkable of these differentiations is that the reproductive functions are concentrated in a single pair of individuals, the king and queen. In some species, especially among the tropical African termites, the queen attains to a gigantic size owing to the great development of the ovaries, and during adult life continues to lay eggs, sometimes at the rate of about one per second. Although the actively reproductive individuals are only a single pair there exist also reserve individuals to take their place in case of accident. These reserve individuals normally remain in an immature state but the community is able in case of emergency, by some unknown method of treatment, to bring about sexual maturity and qualify the reserve individual to take the place of the original king or queen.

Termites, as is suggested by the popular name “white ants”—misleading, as they have nothing to do with the true ants—have their cuticle for the most part thin and transparent, allowing the white fatty body to show through it. In correlation with this transparent nature of the body-wall termites habitually avoid the light: they live within nests

and galleries constructed of the faecal remains of woody matter passed through the alimentary canal, or of earthy material. Some species do much damage in tropical countries by excavating woodwork until nothing is left but a thin outer shell.

Many of the Neuroptera such as the dragon-flies, may-flies, and caddis-flies have aquatic larvae and in such cases the life of the mature fly (imago) may be very short. The adult flies often form favourite food of fresh-water fish (Perlidae—"stone-flies"; Ephemeridae—may-flies, "duns," "spinners"; Sialidae—alder-flies; Phryganeidae—caddis-flies). As is well known to fishermen the last ecdysis, resulting in the emergence of the adult fly, is liable to occur in large numbers of individuals about the same time. Over tropical rivers (New Guinea, Paraguay) what looks like a thick snowstorm may sometimes be observed, caused by the emergence from the water of myriads of snowy-white may-flies.

The COLEOPTERA or Beetles may be said to be the predominant order of insects at the present day. About 150,000 species have already been catalogued. The typical beetle possesses clearly marked characteristics. The thickness and hardness of the chitinous exoskeleton reaches here its maximum development. The anterior wings are purely protective in function, forming the thick elytra the edges of which fit accurately together along the middle line of the back. The mouth-parts are of the biting type and the life-history shows well-marked metamorphosis—the larva being a grub or maggot, and the pupa usually having a soft cuticle and showing distinctly the appendages and other external features of the adult.

Some beetles do damage by attacking crops, stored grain, timber, furniture, but for the most part the Coleoptera are insects which do not come into any important direct relation to man.

The HYMENOPTERA are especially characterized by the hooking together of the fore- and hind-wing on each side so that they work as if they were a single continuous wing. The mouth-parts are adapted for biting, licking and sucking. In the female the hind end of the body carries long slender projecting pieces which form an **ovipositor** for depositing the eggs in crevices or in holes bored by it for the purpose. In the Bees, Wasps and Ants, the ovipositor has given up its original function and become a weapon—the sting. The poison (Formic Acid) which adds pain to the wound possibly served as an antiseptic secretion when the ovipositor performed its original function. In the life-history of the Hymenoptera there is well-marked metamorphosis, the larva being a grub and the pupa showing clearly the projecting appendages and other features of the adult.

The Hymenoptera represent a very high grade of insect evolution, both in their structure and in their psychical features. The latter is specially apparent in those members of the group (bees, ants) which live in complex social communities. Here, as in the case of the termites, those types which have made a success of communal life show an intense specialization of the individuals for different functions in the community. Here again we see in the Bee a restriction of the reproductive function, in so far at least as the female sex is concerned, to a single individual—the queen. The ordinary females in the community are kept from attaining sexual maturity by being fed with different food and these sterile undeveloped females are the workers of the community. More than one female may receive the food necessary for sexual development, but in such a case the first queen that reaches the adult condition proceeds to sting the others to death. This is apparently not the only way in which sexual development is controlled. The males or drones are produced from eggs which develop by parthenogenesis, i.e. without being fertilized, and it is believed that the queen, whose spermatheca has been filled with spermatozoa during the first flight, is able voluntarily to prevent or to allow access of the spermatozoa to the eggs as they are being laid.

In the case of the Ants the community consists of functional males and females provided with wings, and wingless undeveloped females which may be differentiated into ordinary workers and “soldiers.” In particular species various extraordinary types of specialization are found. Thus in certain ants which feed on honey (*Myrmecocystus*, etc.) some of the individuals are differentiated as honey-pots, taking in surplus honey until the abdomen is swollen out into a large globe, and hanging on to the roof of a special store chamber in the nest. Again in *Colobopsis* certain of the workers have enormously swollen heads which serve as animated stoppers to the galleries leading to the nest.

Among the Hymenoptera are included the Gall-flies which deposit their eggs in the tissues of plants, the presence of the egg or of the larva that develops from it stimulating the plant tissue to produce a gall or tumour having a quite definite specific appearance according to the species of Gall-fly. The Ichneumon-flies deposit their eggs on or in the bodies of other insects, usually the larvae of Lepidoptera, and play a great part in keeping the numbers of these insects in check.

A common feature of the Hymenoptera is that the first segment of the abdomen is fused with the thorax: in many members of the group

the portion of abdomen immediately behind this first segment is constricted to form a slender "waist," which therefore does not mark, as one might have expected, the boundary between abdomen and thorax. In certain of the Wasps this waist is very long and slender. These wasps frequently exhibit very interesting habits inasmuch as they store the nests in which they lay their eggs with spiders, or caterpillars or other insects, which they have completely paralysed by stinging, so that the young wasp on hatching finds ready at hand an abundant supply of fresh, indeed living, food. In some cases it has been observed that the wasp is able with great skill to insert the sting straight into the main nerve-ganglia of the victim so as to ensure its complete paralysis.

The Formicidae or Ants in their large and complex communities show, in addition to the high degree of specialization already alluded to, a highly complex social organization and many wonderful abilities and habits. Some of the South American ants inhabiting districts liable to inundation construct special refuges in trees to which they retire during the floods. *Oecophylla* in Ceylon uses its own larva, with its silk-glands opening at the head end, as an animated tube of cement to fasten together the edges of leaves curled into tubular shelters. *Polyergus* of Europe and America raids the nests of certain other ants and carrying off their larvae and pupae rears them as slaves: they have in the course of ages become so dependent on their slaves as to have actually lost their power of feeding their own young. Another common European ant of the genus *Lasius* keeps domesticated aphides which provide it with sweet honey-dew. *Atta*, a large black ant of the American continent, cuts disc-like pieces out of the leaves or petals of trees which it conveys into underground excavations and there uses as a nutritive medium on which to cultivate a particular species of fungus. The ants are able in some way to modify the growth of the fungus so that it forms spongy masses which serve as food for the community. The ants of the American genus *Eciton* are remarkable from the fact that the community does not form a permanent abode but merely temporary camps in hollow trees, under logs, or in other suitable situations. Normally the community is on the march, spreading over a considerable area of ground and consuming everything eatable it encounters.

The main features of the LEPIDOPTERA—Butterflies and Moths—have already been mentioned under such headings as wings, mouth-parts, and metamorphosis. In the larva glands, probably corresponding with the salivary glands of other insects, open on a projecting papilla about the middle of the labium. The secretion as it issues from the gland hardens

to form a thread of silk, and in various species including the ordinary silk-worm—the larva of the Moth *Bombyx mori*—the larva fashions this thread into a cocoon with which it surrounds itself before entering on the pupal stage.

Of the main orders of insects it is the DIPTERA that is of the greatest importance to the student of medicine. The most conspicuous characteristic is the reduction of the hind-wings to the club-like inconspicuous halteres. In the life-history metamorphosis takes place. The larva may be in the form of a grub or maggot, living amongst decaying plant or animal matter, or leading a parasitic existence. In other cases the larva is aquatic, the details of the more or less elongated body differing in different cases (see e.g. Fig. 107). The many species of Mosquitos¹ or gnats are grouped together under the name Culicidae. They feed commonly on plant juices but in the female, which alone sucks blood, a meal of blood is apparently essential for the complete growth and maturation of the eggs.

In marshy districts in the tropics, e.g. in tropical America, mosquitos may exist in such numbers as to make life almost intolerable to freshly arrived human beings, although fortunately immunity is eventually developed to the poison of their bite. The main objectionableness of mosquitos resides, however, not in the irritation caused by their bite² but in the fact that they are the transmitters of various disease-producing parasites. In this connexion there are two specially important types to be distinguished, represented respectively by the genus *Culex* and the genus *Anopheles*—both of them common in warm and temperate climates. As the anopheline type is responsible for transmitting the parasite of malaria it is important to be able to distinguish it from the culicine type. The correct identification of the species of mosquitos is a matter for specialists but there are certain conspicuous peculiarities which usually enable one to recognize an anopheline mosquito at a glance. The most conspicuous of these is the attitude assumed by the mosquito either when at rest or when about to bite. The culicine mosquito assumes the attitude shown in the right-hand figure at the top of Fig. 107: the abdomen is nearly parallel to the substratum; the head and proboscis is

¹ Mosquito is the ordinary Spanish word for a small fly, although in English it has come to be used in a restricted sense for the long-legged gnats called in Spanish Zancudo.

² The intense irritation caused by the injection of the mosquito's salivary secretion is due not to any poison excreted by the mosquito, but to the presence of symbiotic fungi belonging to the group Entomophthorineae which live in three pocket-like diverticula of the oesophagus and are passed into the wound along with the salivary secretion when the mosquito bites.

bent down at an angle. The anopheline mosquito on the other hand (top left-hand figure) has its abdomen tilted up at an angle to the solid surface so as to be practically in line with the proboscis, the insect

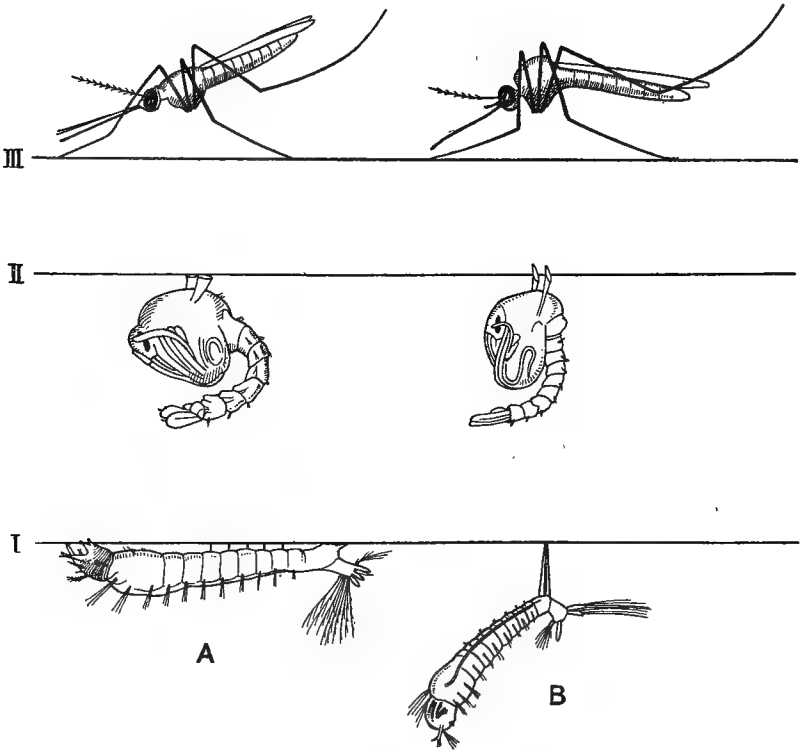

FIG. 107.

Diagram to illustrate the life-history of *Anopheles* (A) and *Culex* (B). (Based on a diagram by Nuttall, in Hindle's Blood-sucking Flies.)

Note (1) that the adult female *Culex* has very short maxillary palps whereas in *Anopheles* of both sexes, as in the male *Culex*, they are as long as the labium;

(2) That in the pupa of both genera the respiratory openings or stigmata are situated at the ends of paired trumpet-shaped projections from the thorax; and

(3) That in the larva of *Culex* the stigmata are situated at the tip of a tubular projection from the eighth segment of the abdomen, and further that the natural position of this larva is hanging downwards from the surface-film of the water, while that of the larva of *Anopheles* is horizontal immediately beneath the surface-film.

having consequently the appearance of standing on its head. Other characteristic differences which are of use in distinguishing between anopheline and culicine mosquitos in different phases of their life-history are shown in Fig. 107.

MOSQUITO CONTROL

Malaria—one of the most debilitating and widely spread of all diseases, and Yellow Fever—one of the most dangerous, not to mention lesser diseases, being spread entirely by the bites of mosquitos it follows that keeping down the numbers of these insects to the minimum, in regions where natural conditions favour their existence, is an insistent need. Its successful accomplishment may indeed be an essential condition to the continued existence of a white community in a particular locality.

It is in warm climates where mosquitos carry on their life-history throughout the year that their control is especially necessary. In regions of wide-spreading tropical swamps it is of course out of the question to think of exterminating mosquitos entirely, but even in such places much may be done to diminish their numbers within actual human settlements owing to the fact that normally mosquitos do not travel any great distance.

What renders the problem of mosquito control a practical one is the fact that the earlier and normally much longer portion of the life-history is passed in the form of a larva (Fig. 107, I) or pupa (Fig. 107, II,) which lives in water but has to breathe air by means of a pair of stigmata, situated in the pupa of *Anopheles* and in the larva and pupa of *Culex* at the end of projections from the body. The line of action indicated therefore is to take measures (1) to ensure, if possible, that bodies of water suitable for the larvae and pupae shall not exist in the immediate neighbourhood of human habitations, and (2) should such be in existence to render them uninhabitable by the mosquito larvae and pupae. The latter object may be attained most easily by covering the surface of the water with a thin film of oil which blocks up the stigmata and renders it impossible for the young mosquito to breathe. The oil¹ may be sprayed on to the surface of pools two or three times a week, or allowed to drip from a tin or drum with a small hole plugged with cotton waste.

Oiling is merely temporary in its effects and in the case of permanent settlements more definitive measures are required. All unnecessary collections of water which may afford suitable breeding grounds for

¹ Any cheap oil. Its efficiency is said to be much increased by the addition of "larvacide" prepared in the following way. Carbolic Acid (150 gallons) is heated to nearly boiling point and Resin (150-200 lbs.) stirred in till dissolved. Solution of Caustic Soda (30 lbs. in 6 gals. water) is then added and the whole stirred for about five minutes. If a little of the larvacide is added to a little water it should emulsify: if it does not do so it should be heated further until it does (Jacobs).

mosquitos should so far as possible be abolished. Care should be taken not to allow old tins or other vessels to lie about on the ground. Pools should be drained and permanent springs where water oozes out should be covered with gravel or cinders.

Accumulations of water which cannot be abolished should be rendered inhospitable to the mosquito larvae. Large pools round lakes should be opened up so as to allow free access of insect-eating fish. Open ditches should be kept free from water-weeds which afford shelter to the larvae. Water butts should be covered in with sacking or wire gauze, an overflow being provided some inches lower down to ensure that the water level shall not rise up to the screen and so become accessible to the egg-laying mosquitos.

In cold temperate climates the malaria problem is less insistent, the long cold season allowing the majority of malarial patients to recover sufficiently to be no longer infective to mosquitos that bite them. In Britain Malaria or "Ague" is in normal times of little importance but at particular periods, especially after great wars, epidemics are liable to be started by the arrival in the country of large numbers of persons infected with the parasite who serve in turn to infect the local anopheline mosquitos. Of these there are three species of *Anopheles*—*A. maculipennis*, *A. bifurcatus* and *A. plumbeus*.

A. maculipennis is the most important species of the three, as it is common and frequents the neighbourhood of houses. It begins to deposit its eggs in the spring in weed-grown ditches and ponds in the neighbourhood of houses. A point to be noted is that this species is normally tided over the winter season not, as is usual, in the larval condition but in the adult stage—fertilized females hibernating in warm cowsheds, stables or other outhouses where they may readily be found hanging on to the roof. These hibernating females are not entirely inactive for they take advantage of occasional warm sunny days to get a meal of blood. It is obvious from what has been said that the numbers of *A. maculipennis* in such a cold temperate climate as that of Britain are controllable (1) by the destruction of the hibernating females by fumigation or whitewashing and (2) by removing the vegetation from ditches and ponds near houses.

A. bifurcatus, whose larvae frequent the mud at the bottom of ditches and winter in that condition, and *A. plumbeus*, whose larvae have been found usually in holes in trees, are more elusive as regards control measures but they are of much less practical importance than *A. maculipennis*.

No special attention has been drawn so far to the obvious advisability

of guarding against the bites of infective mosquitos. In regions where mosquitos are abundant it is quite impossible when leading an ordinary out-of-door life to avoid altogether being bitten. But it should be remembered that only a small proportion of mosquitos are infective and consequently *any* reduction in the number of bites means a reduction in the chance of infection. The hours of sleep should be passed in the shelter of an efficient mosquito net, properly used, and for persons on night duty in the midst of swamps it is worth while to smear the exposed parts of the skin with some oil repellent to mosquitos and other biting insects¹ although such mixtures are themselves apt to cause much irritation to persons with delicate skins. In the case of regions where malaria is not of normal occurrence the immigration of numerous malarial patients makes it of importance to take measures to reduce the chance of their infecting the local mosquitos. Such patients should be prevented so far as possible from settling in fen lands and other low-lying districts where mosquitos are more numerous than elsewhere, and patients actually in such districts should during their attacks be kept in the seclusion of mosquito nets or gauze-screened rooms.

Stegomyia, the genus concerned in the spread of Yellow Fever and Dengue Fever, is controlled by the methods already mentioned, but it should be remembered that mosquitos of this genus are particularly prone (1) to breed in water-butts, old tins and other receptacles, and (2) to haunt the interior of houses and ships. In the latter case they are best cleared out by fumigation,² care being taken to paper up all chinks, to leave the room or cabin sealed up for three hours, and to *burn* the apparently dead mosquitos.

The CHIRONOMIDÆ include a large variety of Midges. The genus *Chironomus*, one of the commonest, has a worm-like aquatic larva which in some species is coloured red by haemoglobin ("Blood-worms"). In the genus *Culicoides* or *Ceratopogon* the female is blood-sucking and is in fact the commonest type of blood-sucking midge or "sand-fly." In some regions these midges are even more annoying than mosquitos, for owing to their small size ordinary wide-meshed mosquito-nets are no protection against them, and owing to their occurring in swarms, not every night but only occasionally, immunity to their poison is not developed so readily as in the case of mosquitos.

¹ E.g. Oil of Cassia 1 part, Red Oil of Camphor 2 parts, Lanoline or Vaseline or Salad Oil 4-5 parts (Howlett).

² One pound of sulphur per thousand cubic feet of room. Burn in an iron pan moistened with spirit.

The PSYCHODIDÆ include *Phlebotomus* a small black "Sand-fly" or midge which may be recognized by its sharp almost flea-like darts from side to side, and by the characteristic fashion in which it holds up its wing when biting. It is the transmitting agent of "Sand-fly Fever" or "Three-day Fever" or "Pappataci Fever" (p. 80).

The TIPULIDÆ include *Tipula*, the Daddy-long-legs, the underground larva of which ("Leather-jacket") does much damage to crops.

The SIMULIIDÆ include the very blood-thirsty midges or sand-flies of the genus *Simulium*, with large clear wings, which occur occasionally in swarms in Britain and in some warmer climates form a great pest.

The TABANIDÆ include the many species of Gad-flies, Horse-flies and Clegs. The common noiseless light-footed "Cleg" belongs to the genus *Haematopota*. The genus *Chrysops*, in which the eyes are often golden-green and the wings partially dark in colour (Widow Fly or Viuda of Spanish America), is incriminated as the transmitter of *Filaria loa* (p. 206).

The SYRPHIDÆ include many of the most abundant kinds of flies. Some of them present a remarkable mimicry of Bees and Wasps, and these have possibly given rise to the ancient legend of Bees coming forth from decaying matter such as carcasses.

The MUSCIDÆ include a number of the most abundant types of fly, some of them of practical importance in connexion with the spreading of disease. They are characterized by their short three-jointed antennae with a jointed, sometimes feathery, bristle projecting from the terminal segment.

The common large House-fly (*Musca domestica*, identified by the four dark lines which run along the dorsal surface of the grey thorax), world-wide in its distribution, does a certain amount of useful work as a scavenger, but any good that it does in this way is far overbalanced by the harm that it does in spreading diseases of the alimentary canal such as Typhoid, and where large numbers of non-immune human beings are crowded together under conditions favourable to the microbes of such diseases its control becomes of the greatest practical importance.

The eggs, to the number of about 800 from a single female, are deposited in rotting material or preferably in fresh faeces of horse or man. After about twelve hours¹ the larva, a slender white grub or maggot rounded at its hinder and pointed at its front end, hatches out. The larva grows rapidly to a length of about 12 mm., and after about 5-8 days crawls into a dry spot and metamorphoses into the pupa, and

¹ These time periods are greatly shortened by warmth and lengthened by cold.

after about 5 days in this stage the adult fly emerges. About 7-10 days later the female begins to lay eggs.

It is during the adult phase that the fly becomes a source of danger. Catholic in its tastes it is at one moment wandering about amongst and feeding on human faeces, at another wading in the jam on a tea-table, at another creeping about food in course of preparation in a kitchen. Human faeces are liable to be crammed with microbes of diseases of the alimentary canal, such as Diarrhoea, Typhoid, Cholera, Dysentery, and such microbes taken into the alimentary canal of the fly are apt to remain alive and even in the case of bacteria to multiply within it. The fly when feeding, especially when feeding on sugar or other soluble material, exudes from time to time a drop of clear fluid from its mouth and both this and the faeces of the fly are liable to infect the food on which they are deposited. Portions of faecal material containing microbes are also liable to adhere to the feet or other parts of the fly and to be left behind when it wades in jam or other food-material. Such disease germs lying in wait in food-material are obviously liable to infect with disease human beings who swallow them.

It is clear that House-flies constitute a distinct menace to health, and therefore that their numbers should be kept down to the minimum about human habitations. The adult flies should be destroyed by fly-papers, "tangle-foot,"¹ or poison.² But here again, as is the case with mosquitos, the most effective measures are those directed against the earlier stages of the life-history. The all-important thing is to prevent the accumulation of garbage, fresh manure, or faecal matter in places accessible to flies and in the neighbourhood of habitations. Such materials are preferably incinerated: if they have to be accumulated, the accumulations should be buried under at least two feet of earth.

The genus *Fannia* (or *Homalomyia*) includes the small House-fly (*F. canicularis*) and the Latrine fly (*F. scalaris*), distinguishable from *Musca* by their smaller size, the greater overlap of the wings when at rest, the plain (not feathery) bristle of the antenna, and the fact that two nervures

¹ Heat together 62 parts of resin, 26 of castor oil, and 12 of honey. Dip skewers or iron wires in this and leave about. When well covered with flies incinerate them in a flame and recoat the wire.

² Sodium arsenite 1 lb. (or Cooper's Sheep-dip Powder 3½ lbs.), sugar 10 lbs. (or treacle 2 gals.), water 10 gals. Owing to its very poisonous character it is well to colour this solution with some distinctive dye. Cloths moistened in it may be hung up; or bottles of it may be left standing about with wick dipping into the solution.

Another good fly poison consists of 3 per cent Formaline in sweetened milk or water. Leave about in rooms during the night in saucers, taking care that no other fluid is available for the flies to drink.

run parallel to the tip of the wing, whereas in *Musca* they converge so as nearly to meet. These flies are both very common, but they are probably of less importance from the health point of view as they are less apt to interfere with human food. The larvae, recognizable by the pointed projections from the sides of the body, are occasionally found as parasites in the intestine of man.

The Blue-bottles or Blow-flies (*Calliphora*) and the Green-bottle (*Lucilia*), which normally deposit their eggs on dead meat and fish, are well-known flies, and both are liable on occasion to lay their eggs in uncovered wounds.

Among the Muscidae there are also included a number of blood-sucking flies. The common biting Stable-fly, *Stomoxys*, is usually mistaken for a House-fly, which it closely resembles in general appearance, apart from the straight pin-like proboscis projecting forwards from its head. Closely allied to *Stomoxys* is the African genus *Glossina* (Tsetse), recognizable by the wings when at rest lying flat one over the other and projecting back beyond the tip of the abdomen. As already indicated, the various species of *Glossina* are of great practical importance from their acting as intermediate hosts for disease-producing trypanosomes. The Glossinas are readily attracted by moving bodies; they are active during the day; and like mosquitos they avoid white surfaces—so that white garments are desirable in Tsetse-infested districts. The egg develops within the uterus of the parent and there is eventually brought forth a fully developed larva which is deposited on loose soil into which it at once burrows and pupates. Deep shade and a certain amount of moisture are essential to the well-being of the Glossinas, and consequently something can be done towards keeping down their numbers in the neighbourhood of settlements by clearing the zone along the margins of lakes and rivers of trees and brushwood.

The OESTRIDÆ are remarkable from the fact that the larvae are parasitic on vertebrates: the adult fly as a rule does not feed, the mouth parts being reduced to functionless vestiges. *Gastrophilus* deposits its eggs on the fore-parts of horses, and when licked off and swallowed they develop into "bots," peculiar larvae surrounded by rings of hooks which hang on to the lining of the stomach, often in great numbers. *Hypoderma* similarly deposits its eggs on the body of cattle, but in this case the larva ("warble") takes up its position under the skin of the back. These warbles when numerous do much damage to hides by the perforations through which they make their way out. Occasionally they occur in man, and in South America they are in places regarded popularly as the larvae of a large moth!

In the genus *Oestrus* the egg is retained within the body of the mother until it has developed into a young larva. This is deposited in the neighbourhood of the nostrils and finds its way into the frontal sinuses—irregular cavities in the skull communicating with the nose—where it passes its larval existence.

In all these Oestridae the larva makes its way out of the body before it assumes the pupal condition.

The last subdivision of the Diptera calling for special mention is that of the HIPPOBOSCIDÆ, the adults of which are blood-sucking. They show a tendency to pass their time creeping about among the feathers or hair of their host instead of alighting on it merely for short periods when feeding. Correlated with this we find in different members of the group less or more marked reduction of the wings, culminating in such forms as the Sheep-keed (*Melophagus*), in which they have entirely disappeared, the creature spending its whole life among the wool of the host. Such cases are of interest as illustrating how members of a group of animals characterized by great activity and freedom of movement may become transformed in the course of evolution into highly specialized parasites whose life is confined entirely to the body of their host.

Having dealt with the eight main orders of insects we now come to three less conspicuous groups, the members of which are entirely parasitic in habit, and in correlation with this are wingless and in other ways modified in structure.

The Fleas (APHANIPTERA or Siphonaptera) are especially characterized by the shape of the body, being greatly compressed from side to side, instead of being depressed dorsiventrally as is the case with other flattened insects. The mandibles are long piercing styles, and between them is an unpaired piercer which may be hypopharynx or labrum.

There are many species of flea, each having its favourite host but being often quite ready to bite animals of other species. In the case of the ordinary human flea (*Pulex irritans*) the small whitish worm-like larva lives in dust, especially under carpets. Where large numbers of eggs have been deposited and where the resulting fleas have had no opportunity of being carried away by human beings, as in deserted huts or camping grounds, they may accumulate in myriads. Persons camping in such spots may develop a high temperature from the bites of hundreds of fleas. After a time, as in the case of other biting insects, a considerable degree of immunity is developed to the irritation caused by the bite of the flea. For keeping away fleas the most effective safeguard is the frequent washing of floors as the insects in question cannot

stand water. In order to get rid of larvae already existing some disinfectant such as cresol should be added to the water (1 in 20).

Of the ordinary fleas those of the Rat (especially *Pulex*, or *Xenopsylla cheopis*—the common rat-flea of the tropics) are of special importance, for plague is normally a disease of rats, and fleas feeding on infected individuals become themselves infective and capable of inoculating human beings by their bite. Fleas, in fact, are the regular means by which plague is spread both from rat to man, and from one human being to another.

A peculiarly modified flea which gives trouble in dry tropical regions is the jigger or chigoe (*Sarcopsylla penetrans*). In this case the fertilized female burrows into the skin, preferably of the toe, until completely hidden except the tip of the abdomen. The abdomen eventually becomes greatly distended reaching the size of a small pea. The eggs are shed to the exterior, and if the stockings are not frequently changed the larvae may undergo their complete development therein and the feet become infested by a large number of jiggers. The jigger under normal circumstances does not cause pain, the sensation being a mere slight itching feeling, but there is always a chance of sepsis being set up by some microbe getting into the wound. Consequently care should be taken when extracting the jigger to use iodine or some other efficient antiseptic.

Jiggers are common in the warmer parts of the New World, infesting the feet of human beings and also of dogs. Introduced into West Africa they have spread across the continent, and will no doubt in time establish themselves in all tropical countries.

The Lice (ANOPHLURA) are small soft-skinned insects which live on the skin of mammals. Two species—(1) *Pediculus humanus*, with its two varieties the Head Louse (“*P. capitis*”) and the Body Louse (“*P. vestimenti*”), and (2) the Crab Louse (*Phthirus pubis*)—are common parasites of man where uncleanly conditions prevail. Any one whose occupation takes him into proximity to uncleanly persons is liable to be attacked by these pests and these attacks are now known to be not merely unpleasant but dangerous, as it has been clearly shown that lice are responsible for the spread of Typhus, “European” Relapsing Fever and Trench Fever. The infection is as a rule not conveyed by the microbe being injected with the salivary secretion. The microbes gain access to the body through abrasions caused by scratching or other breaks in the skin. And in the case of trench fever dried excreta from the insect, such as may readily be blown about as dust, are capable of causing infection if they get into wounds of the skin.

The MALLOPHAGA or Biting Lice include a large number of parasites

of Birds and Mammals. As the name indicates they have a general resemblance to Lice but unlike these animals they have mouth parts adapted for biting, not for sucking blood. A species of *Trichodectes* is one of the common parasites of the Dog and, as will be remembered, it acts as host for the cysticeroid stage of the tapeworm *Dipylidium caninum*.

IV. The ARACHNIDA include a number of very different-looking types of animal, all of them adapted to an air-breathing terrestrial existence with the exception of the King-crab (*Limulus*). The fact that the lungs of the air-breathing arachnids in early stages of their development resemble, as mentioned on p. 223, the appendage-borne gill-books of *Limulus* leads us to conclude that the ancestors of the lung-breathing arachnids of to-day passed through an aquatic phase of evolution, whatever their habit may have been at a still earlier period of evolutionary history.

The XIPHOSURA are represented at the present day by the King-crab (*Limulus*), which lives on sandy bottoms in shallow water off the eastern coasts of North America and Asia—an interesting example of the discontinuous geographical distribution often met with in ancient types of animal life.

The SCORPIONIDEA include the many species of scorpion, insect-eating creatures of nocturnal habit, found in all warm countries. They are of practical interest from the conversion of the telson into a sting by which poison is injected into the prey. The sting is also made use of for defence—e.g. when a foot is incautiously thrust into a boot into which a scorpion has retired for the day, and the effects of the poison may be serious.

The ARANEAE are the Spiders, recognizable by the plump soft-skinned opisthosoma attached to the prosoma by a narrow "waist." They also are provided with poison-glands, but these open at the tip of the first pair of appendages (chelicerae). The poison is powerful and the bite of several species in different parts of the world is credited with serious effects even to man. One of the characteristic structural features of the spiders is the complicated arrangement of silk-glands which fill up a large part of the opisthosoma. The silk is used for the construction of egg-bags, nests, or more or less elaborate webs for the capture of flies. The different silk-glands differ in the quality of their product and in the case of the more elaborate webs the last portion to be constructed is in the form of a fine thread carried round and round the web in a polygonal pattern and composed of a highly elastic core with a coating of very

sticky secretion which runs together into tiny droplets studded along the course of the thread.

The PHALANGIDEA include a great variety of creatures, some of them exceedingly common and usually mistaken for long-legged spiders. They are easily distinguished from the true spiders by there being no constricted "waist" between the prosoma and the opisthosoma.

The ACARINA, including the Mites and Ticks, is the subdivision of the Arachnida which is of the greatest practical importance—many of them leading a parasitic existence on other animals or plants. As in the preceding group there is no marked "waist"; the mouth-parts are usually adapted for sucking. Tracheal tubes are present in the larger Acarines but in many of the small-sized mites, in which the cuticle is very thin and the ratio of surface to volume relatively great, the respiratory exchange takes place through the general surface of the body and there are no special breathing organs.

A few of the mites have an elongated worm-like shape. Some of these live on the leaves of plants, producing galls or causing distortion of the leaves, as is the case with *Eriophyes* or *Phytoptus*, common on the leaves of the black currant: others are parasitic on animals as e.g. *Demodex*, the "Blackhead," a common parasite in the hair-follicles of the face of man.

The Sarcoptidae include the Itch-mites of the genus *Sarcoptes* which inhabit the skin of mammals, causing the diseases known as Mange and Scabies or Itch. Where large numbers of human beings are crowded together, as they are liable to be on active military service, Scabies is liable to spread and affect a large proportion.

The adult mite burrows along in the substance of the skin. The female is fertilized in the burrow, and in the course of its life, which lasts at least three weeks, it deposits 20-50 eggs. After $2\frac{1}{2}$ - $3\frac{1}{2}$ days the egg gives rise to a six-legged larva, and this in $1\frac{1}{2}$ -3 days to the eight-legged pupal or "nymph" stage. After 1-2 days the sexual stage is reached.

There are various other genera allied to *Sarcoptes*. *Tyroglyphus* is the cheese-mite, while *Glyciphagus* sometimes becomes a serious pest through its infesting in myriads household furniture. The latter mite is exceedingly difficult to get rid of, for even fumigation or "gassing" with the most poisonous gases is apt to leave in inaccessible crannies a few survivors which are sufficient to start a fresh invasion.

The Ticks (Argasidae and Ixodidae) are much larger than the other mites: they may reach an inch in length when distended with blood. When undistended the body is flattened. The mouth-parts are adapted for sucking: an unpaired "hypostoma" and a pair of chelicerae are

provided with recurved hooks, and these organs when thrust into the skin of the host give a firm attachment. If the tick is forcibly pulled off, these organs are left behind in the skin and may continue to cause irritation for weeks. A tick should therefore be induced to detach itself by applying to its body a small drop of oil which will get into its stigmata and usually cause it to release its hold.

The majority of ticks are grouped together as the IXODIDÆ: they are recognizable by a stiff chitinous plate which covers in the male the greater part of the dorsal surface, and in the female the fore part, all the hinder portion being enclosed in tough leathery skin. *Ixodes* is the common sheep-tick.¹ *Boophilus* and *Rhipicephalus* are of practical importance as transmitters of *Piroplasma* or *Babesia* (p. 64).

The Argasidae are without the stiff chitinous plate on the dorsal surface and the body bulges forwards so as to conceal the head region in a view from the dorsal side. *Ornithodoros*, common about native huts and camping spots in tropical Africa, is the transmitter of African Relapsing Fever (p. 77).

The Tarsonemidae are very minute mites which cause injury to plants. A species of *Tarsonemus* has been found recently infesting the tracheal tubes of Bees suffering from "Isle of Wight" disease, and is believed by its discoverers to be the cause of the disease.

The Trombidiiidae include the red Harvest mites the larval stage of which ("Harvest bug"; Bête rouge; Bicho colorado) is apt to get on to the skin of human beings in grassy country and causes intolerable itching by its bite.

V. The CRUSTACEA include a vast variety of arthropods adapted to an aquatic existence. In correlation with this the function of breathing is carried out by gills—thin-walled projections of the body-surface springing as a rule from the appendages. And very commonly some of the appendages are, during at least part of the life-history, modified for swimming. The cuticle is usually stiffened by the deposit, within its substance, of salts of lime. The life-history commonly involves great changes in form between the larval and the adult phase, but these changes are brought about in successive steps without that re-organization of practically the whole body that occurs in the metamorphosis of insects.

A conspicuous feature which usually enables a crustacean to be recognized at a glance is afforded by the presence of *two* pairs of antennae.

The Crustacea are commonly classified in two main groups, the Mala-

¹ The latter name is sometimes erroneously applied to the "sheep-keed" (p. 254).

costraca—including the larger and more familiar types such as Lobsters, Crabs, Sand-hoppers, and “Slaters”—and the Entomostraca, constituted by less conspicuous creatures smaller in size and simpler in structure. It has, not unnaturally, been customary to regard the Entomostraca as representing an earlier phase in the evolution of the Crustacea, but there is much to be said for the contrary view which would regard their simpler structure as being a secondary acquirement correlated with their diminution in size. A strong argument in favour of this latter view is that modern investigations have shown a very striking agreement between the Malacostraca, the Insecta, and the Arachnida, in the number of segments of which the body is built up. There is no agreement between the different species of *Peripatus* or of the Myriapoda as to the number of body segments, so these animals represent an intermediate phase in evolution between the Annelid with its indefinite number of segments, and the Arachnid or Insect with its fixed number of segments. If the Malacostraca had arrived at their definite number of segments by an independent evolutionary path it seems improbable that the resulting number of segments would agree with that arrived at by the Arachnids and Insects. It is therefore tempting to lean towards the, admittedly heretical, view which would regard Insects, Arachnids, and Malacostracous Crustaceans as being all of them modern representatives of a common ancestral type of arthropod in which the number of body-segments had become definite. The Entomostraca, in which the number of segments shows great variation, would be regarded not as having retained the primitive indefiniteness but as having secondarily lost the constancy in number of segments possessed by the ancestors common to them and the other Arthropods.

The most familiar members of the MALACOSTRACA are those which are grouped together under the name DECAPODA—including the Lobsters, Shrimps, Prawns, Hermit-crabs, and Crabs. They are characterized by the possession of a flap-like outgrowth of the body-wall (**carapace**) which grows back from just behind the head and covers in the entire thoracic region with its gills on each side. They possess the array of appendages already described for the Crayfish. They usually pass, during the earlier stages of their life-history, through a characteristic larval stage known as the **zoaea**, provided with long spine-like outgrowths from the head and carapace (Fig. 108).

In certain of the Decapods interesting and characteristic modifications of the abdominal region are seen. In the Hermit-crab this portion of the body is thrust into an empty Gasteropod (p. 267) shell and in correlation with this its cuticle has reverted to a soft membranous condition,

its shape has become lop-sided, and the appendages of the abdomen are reduced in importance except the sixth of the left side which forms a kind of hook for holding on to the columella of the shell. In the ordinary crabs the abdomen is carried permanently tucked forwards underneath the cephalothorax and in correlation with this and its loss of function in swimming it has become greatly reduced in size in the adult although in the *Zoea* stage it is of full size (Fig. 108).

In the *ISOPODA*, characterized by the form of their body, flattened from above downwards, and the *AMPHIPODA*, where the body appears to be compressed from side to side so that the animal lies on its side when taken from the water, there is no carapace. Among the *Isopoda* are a number of genera which have taken to a terrestrial existence, although

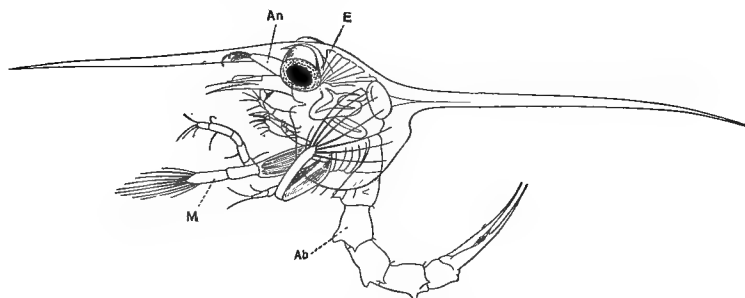

FIG. 108.

Zoea of a Crab (*Corystes*). $\times 24$. (After Gurney, from *The Cambridge Natural History*.)
Ab, Third segment of abdomen; *An*, First antenna; *E*, eye; *M*, first maxilliped.

a damp atmosphere is still essential to their life. Many of these Slaters or Wood-lice are of interest in that they have developed on their flat abdominal appendages fine tubular ingrowths of cuticle which, like the tracheae of insects, serve for breathing air. Other members of the group have taken to living parasitically upon other crustaceans and in some of these the adult female loses all resemblance to a crustacean, being little more than a bag of eggs, although in its young stages its character is clearly recognizable.

The *ENTOMOSTRACA* include an immense variety of crustaceans of which only the chief types can be mentioned. Amongst the *BRANCHIOPODA* are included a number of very common short-bodied creatures, sometimes termed Water-fleas, belonging to such genera as *Daphnia* and *Simocephalus*, which from the small size and transparency of their tissues are excellently suited for demonstrating the essential facts of crustacean structure under the microscope.

The body of the female *Daphnia* or *Simocephalus* (Fig. 109) is flattened from side to side, and all except the head is enclosed between the flaps of the carapace which forms a kind of bivalve shell. The abdomen, which when at rest is bent forwards but which can be suddenly straightened out, terminates in a pair of sharp claw-like extensions immediately dorsal to which is the anal opening. Of appendages there are present a pair of first antennae, reduced to small vestiges in the female; large

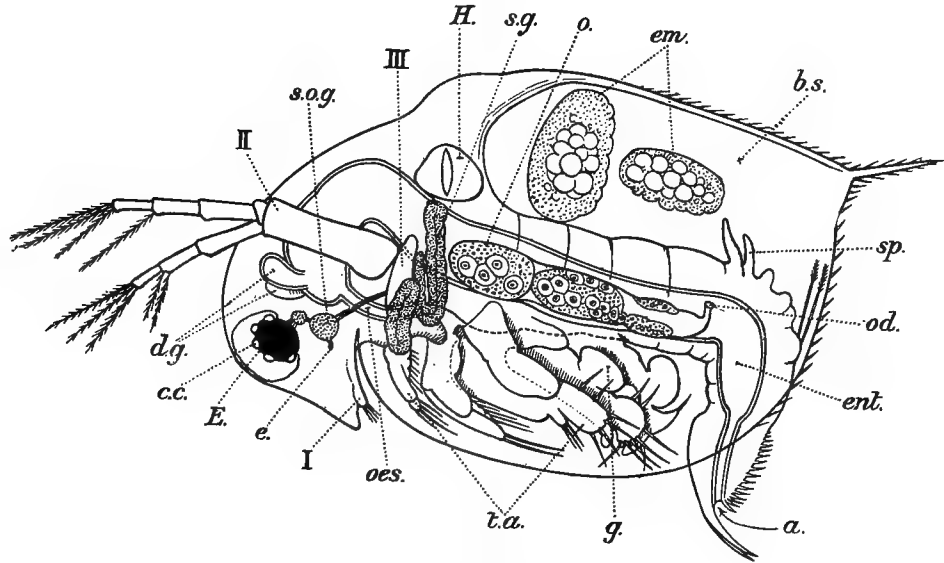

FIG. 109.

Daphnia, adult female. $\times 40$. *a*, Anus; *b.s.*, brood space between dorsal surface of abdomen and carapace; *c.c.*, crystalline cone; *d.g.*, digestive glands; *E*, radiate eye; *e*, simple eye; *em.*, embryos; *ent.*, intestine; *g*, gill; *H*, heart; *o.*, ovary; *od.*, opening of oviduct; *oes.*, oesophagus; *s.g.*, shell-gland; *s.o.g.*, supra-oesophageal ganglion; *sp.*, spikes which prevent embryos from falling out of brood space, in the natural position their points are close to the inner surface of the carapace; *t.a.*, thoracic appendages. I, First antenna; II, second antenna; III, mandible.

second antennae; large L-shaped mandibles; small (first) maxillae; and five pairs of flattened thoracic limbs. The latter possess extensions of their surface of two different types. Round their edges they extend into closely set bristles which make them more efficient for driving a respiratory current of water through the cavity enclosed by the carapace. In addition each possesses a rounded thin-walled bulging of its surface through which respiratory exchange takes place, although no doubt this takes place also through the entire inner surface of the carapace. In the abdominal region the limbs have completely disappeared.

Laboratory specimens are best fed with cultures of green flagellates as such specimens become especially transparent and the alimentary canal stands out distinctly with its green contents. The chief point of interest about the alimentary canal is that its digestive glands, of which as is usually the case in Crustacea there are a pair, are in the form of simple pocket-like outgrowths of the enteric wall. In such a crustacean as a Crayfish or Lobster on the other hand although the corresponding glands are at first simple and pocket-like they become subdivided up so as to form in the adult a complex mass of blindly ending tubes.

The haemocoelic nature of the body-cavity is readily recognizable under the microscope as the blood-corpuscles can be seen driven through its spaces by the beating of the heart. These creatures are of interest in connexion with the history of medical science for it was by observations upon their blood-corpuscles that some of the first steps were made in the scientific investigation of the process of **inflammation**—which plays such a great part in the process of healing—by the Russian zoologist Metchnikoff. He observed how the sharp needle-like spores of a disease-producing fungus *Monospora* swallowed by *Daphnia* perforate the wall of its alimentary canal but on reaching the surrounding haemocoel are at once attacked, ingested, and destroyed by the blood-corpuscles (phagocytes).

The nervous system is of the normal arthropodan type although only the head portion is clearly visible in the specimen when viewed as a whole. The radiate eyes, which have become fused together and sunk beneath the surface, are conspicuous and show the crystalline cones very clearly under the microscope. In addition to them there is a simple unpaired eye recognizable as a small speck of black pigment at the tip of the supra-oesophageal ganglion or brain.

The ovary is an elongated organ lying alongside the alimentary canal and opening on the side of the abdomen into the space between it and the carapace. The eggs when laid pass into this space and remain there during their development, being kept from falling out by spike-like projections from the dorsal surface of the abdomen.

The reproductive phenomena are of special interest. During the greater part of the summer season male individuals are very rare and the females reproduce parthenogenetically. At seasons of the year, however, when climatic conditions are liable to become unfavourable—in autumn when the cold weather approaches and during the early summer when pools are liable to dry up—males (distinguishable by their smaller size, their larger first antennae, and their more rapid and less jerky movements) appear in numbers and the females produce so-called

“ winter eggs ” which are larger, richer in yolk, and devoid of the capacity of developing without fertilization. The fertilized winter eggs after going through the early stages of segmentation become dormant and remain so throughout the period of unfavourable conditions. When ecdysis takes place they remain within the shed cuticle which round the brood-space becomes much thickened and dark in colour. The rest of the shed cuticle breaks away and the two winter eggs are left within a sort of protective case (the **ephippium**) formed by the thickened and dark-coloured portion of the cuticle. These egg-cases float about on the surface, or lie in the mud if the water dries up, and when conditions again become favourable—i.e. in the spring in cold climates—each egg hatches out as a female. These females give rise parthenogenetically to other parthenogenetic females and it is only after several generations that occasional males begin to make their appearance.

The COPEPODA are represented typically by the genus *Cyclops* (see Fig. 94, p. 204) a common inhabitant of fresh water. They have normally a pear-shaped body, without carapace or radiate eyes, and the developing eggs are carried about by the female in the form of rounded masses, usually one on each side, attached to the abdomen.

The young Copepod passes through the well-defined type of larva known as a **nauplius**—a short-bodied larva (cf. Fig. 110) possessing three pairs of appendages by the movements of which it swims. These larval appendages persist as the first three pairs of appendages of the adult—first antennae, second antennae, and mandibles—so that we may regard the nauplius as the precociously developed head region of the individual, the remainder of the body being added on during the later stages of development.

The genus *Cyclops* has already been mentioned as serving as host to the young larva of *Dracunculus* (p. 204). The group Copepoda includes a large number of other genera inhabiting the sea or fresh water and constituting a large proportion of the plankton or drifting fauna. They provide an important food-supply for fish and they play a large part in producing the “ phosphorescence ” of the sea, the actual production of light in such cases being apparently due to some obscure chemical reaction between the sea water and secreted material produced by the skin.

Various Copepods have taken to a parasitic mode of life, infesting especially the gills and skin of fish. Some of these have become extraordinarily modified in structure so as to be quite unrecognizable from their general appearance as Copepods or even as Crustaceans. Even when the adult is modified in this way, however, a clue to the relationships of the creature is afforded by its young stages, there being a typical nauplius larva.

The CIRRIPIEDIA are a group of Crustacea which have entirely given up the free-living existence, being attached to rocks, to floating objects, or to the bodies of other animals, and in correlation with this the bodily structure is greatly modified in the adult—although here again there is a typical nauplius larval stage (Fig. 110, A). The nauplius swims about and after a few days ecdysis takes place accompanied by a considerable change in form. It is now (Fig. 110, B) known as a “Cypris” larva— from its resemblance to the members of the group Ostracoda (p. 266): its body is enclosed in a bivalve carapace, and there are six pairs of

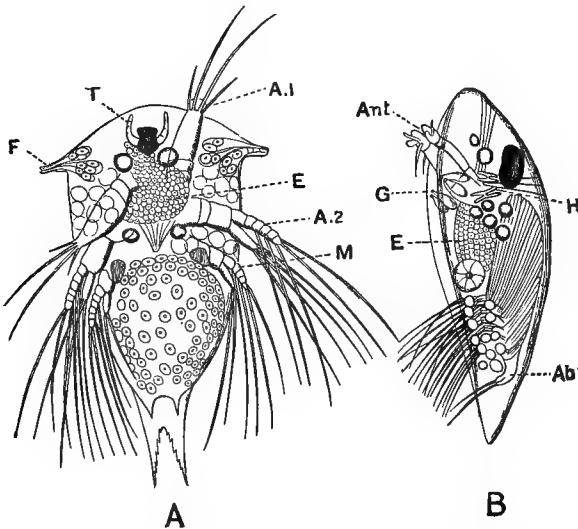

FIG. 110.

Nauplius (A) and Cypris (B) stages of *Sacculina*. \times about 70. (From Geoffrey Smith in *The Cambridge Natural History*, vol. iv.) A.1 and Ant, First antenna; A.2, second antenna; Ab, abdomen; E, undifferentiated cells; F, horn-like projection; G, glands; H, tendon; M, mandible; T, tentacles.

Y-shaped thoracic legs by the movements of which it swims. The first antenna carries a flattened disc upon which opens the duct of a cement gland producing a sticky secretion. When the Cypris larva swims up against a solid object it is apt to adhere to it and it may be observed apparently struggling to free itself, making as it were several steps with its sticky antennae, until at last its attempts cease and it remains fixed in position. The cirripede now gradually takes on its adult form. It remains attached to the solid object by its head end: the body is enclosed in a carapace-like fold of skin termed the mantle; the compound eyes disappear and the six pairs of swimming legs are replaced by much

longer, tapering, two-branched and many-jointed, appendages which serve by their rhythmic movements to drive floating food-particles towards the mouth. The mantle becomes strengthened by the formation of strong white calcareous plates. In the ordinary Barnacles or Acornshells (*Balanus*), the white shells which are seen in numbers on almost every rock just below high-water mark, the form of body is conical but in the pelagic stalked barnacles (*Lepas*), which live attached to floating objects, the head region becomes much elongated to form a stalk on the free end of which the body is borne.

Various Cirripedes are parasitic in habit. Some of these—like the large barnacles found embedded in the skin of whales—are comparatively little modified, but others, such as *Sacculina*—a common parasite of crabs—show the most extraordinary modification, the (hermaphrodite) adult looking simply like a rounded bag projecting from the under side of the abdomen of the host with root-like processes for the absorption of nourishment branching amongst its internal organs. Here, however, as in so many other similar puzzles in the animal kingdom the key to the true relationships of the creature is at once given by the study of its development, which shows (1) that the egg develops into a perfectly typical nauplius larva, thus demonstrating it to be a member of the Crustacea and probably of the Entomostraca and (2) that the nauplius becomes transformed into a Cypris larva and so demonstrates that it belongs to the Cirripedia.

Phenomena of very great general interest and importance have been observed in connexion with the influence of these parasitic cirripedes upon their hosts, the metabolism of the host being upset in some peculiar way that influences the sexual characteristics. The two sexes in Crabs are normally recognizable at a glance, owing to the fact that in the male the abdomen is narrow and devoid of appendages except a pair in front modified for purposes of fertilization, while in the female the abdomen is broad and provided with four pairs of appendages for the attachment of the eggs. Now in males infested with *Sacculina* it is found that a large proportion take on the appearance of females and their testes degenerate. After the *Sacculina* dies and disappears the gonad may become again functional—with the remarkable peculiarity that it may now produce eggs as well as spermatozoa: the whole constitution has been caused to swing towards femaleness by the influence of the parasite. Conversely in an infected female the constitution is caused to swing away from femaleness as is shown by the abdominal appendages diminishing in size but there is here no assumption of characters normally belonging to the other sex.

The last subdivision of the Crustacea, the OSTRACODA, deserves mention for certain genera such as *Cypris* and *Candona* are exceedingly common in fresh water. Some of these are remarkable for the fact that the male sex is believed to have completely disappeared, reproduction being entirely parthenogenetic. They are small creatures and are easily recognized by the bivalve carapace similar in appearance at the two ends.

BOOKS FOR FURTHER STUDY

- The Cambridge Natural History**, Vols. IV. (Crustacea and Arachnida), V. and VI. (Protarthropoda, Myriapoda and Insecta).
Calman. Crustacea, in A Treatise on Zoology, edited by Sir Ray Lankester, Pt. vii. fascicle 3.
Hindle. Blood-sucking Flies.

CHAPTER VII

MOLLUSCA

- I. GASTEROPODA—Snails, Slugs, Whelks.
- II. SIPHONOPODA (or Cephalopoda)—Cuttlefish, Squids.
- III. PELECYPODA (or Lamellibranchiata)—Mussels, Oysters, Clams.

THERE can hardly be a contrast more striking than that between the typical Arthropods, with their hard, jointed bodies and their active movements, and the typical Molluscs or Shellfish, with their soft fleshy bodies and extremely sluggish movements—and yet as will be seen later there are certain fundamental features of structure in which the two groups are alike.

In examining the external appearance of the mollusc one is at once struck by the absence of two conspicuous arthropodan features—the segmentation of the body and the possession of paired appendages. It is only in two of the most ancient types of mollusc, represented respectively by *Chiton*—the most ancient existing type of Gasteropod, and *Nautilus*—the most ancient existing type of Siphonopod, that we find traces of segmentation present—hinting to us that the far back ancestral creatures from which the molluscs of to-day are descended had in all probability segmented bodies.

The mollusc possesses typically a definite head region at the tip of which is the mouth and which carries a pair of eyes. The Gasteropod (Fig. 111, A) has usually also one or two pairs of tentacles, the epidermis covering which is crowded with sensory cells. In the Siphonopod the head region extends into numerous sticky tentacles (*Nautilus*—Fig. 112), or into a circle of eight or ten long arms (Fig. 111, B) carrying numerous powerful suckers by which the animal grasps its prey or, when at rest, holds on to its rocky substratum.

The mollusc like the arthropod possesses a hard exoskeleton, but this instead of covering the entire surface is confined to the skin of

the dorsal side of the body, known as the **mantle**, where it is greatly thickened and calcified, forming the characteristic **shell**. Correlated with the presence of the rigid shell dorsally this portion of the body-wall has little development of muscle. Ventrally on the other hand there is a great development of muscle, forming one of the most characteristic organs of the mollusc—the **foot** (Fig. 111, *F*).

The shell is composed typically of three distinct layers. Externally is an uncalcified layer—the **periostracum**—well seen in fresh-water mussels. This uncalcified cuticle in the mollusc is composed not of ordinary chitin but of a somewhat different substance—**conchiolin**, resembling silk in its composition. Next to the periostracum is the thickest layer—the **prismatic layer**—composed of practically pure calcium salts (mainly carbonate) arranged in minute prisms perpendicular to the surface of the shell. Lastly and internally is the thin **nacreous layer** composed of the same calcium salts deposited in very fine sheets, one over the other. These sheets cropping out all over the surface form extremely minute ridges which cause interference between the rays of light reflected from the surface and so produce in many cases the beautiful iridescence which gives this layer its popular name “mother-of-pearl.” As the mollusc grows the shell is enlarged round its edge by the mantle adding on to the periostracum and prismatic layers, while additional deposits of nacreous layer are formed by the activity of the mantle all over the inner surface of the shell. Occasionally small pockets are formed in the outer surface of the mantle, e.g. round some intruding parasite such as a larval Trematode or Cestode, and if such a pocket becomes closed in its cavity becomes filled with concentric layers of nacre forming an isolated rounded mass—a **pearl**. Pearls are liable to occur in many different molluscs, mostly Pelecypoda, including the common mussels (*Mytilus*) and fresh-water mussels (*Anodonta*, *Unio*), but the finest and most abundant specimens are obtained from the Pearl oyster of tropical seas (*Avicula*).

The shell shows great variety of form, the most primitive probably being a simple shallow dome covering the dorsal surface. In two of the main groups—the Gasteropoda and the Siphonopoda—this dorsal surface bulges out greatly, forming the **visceral hump** which contains most of the internal organs of the body. To accommodate this the shell is drawn out into a long cone, and to avoid unwieldiness the cone grows in such a lopsided manner as to form a tightly coiled (usually right-handed) spiral which may be anything between perfectly flat, as in some of our common fresh-water snails (*Planorbis*), and a long slender tapering screw (*Turritella*). In some cases the visceral hump does not continue to fill

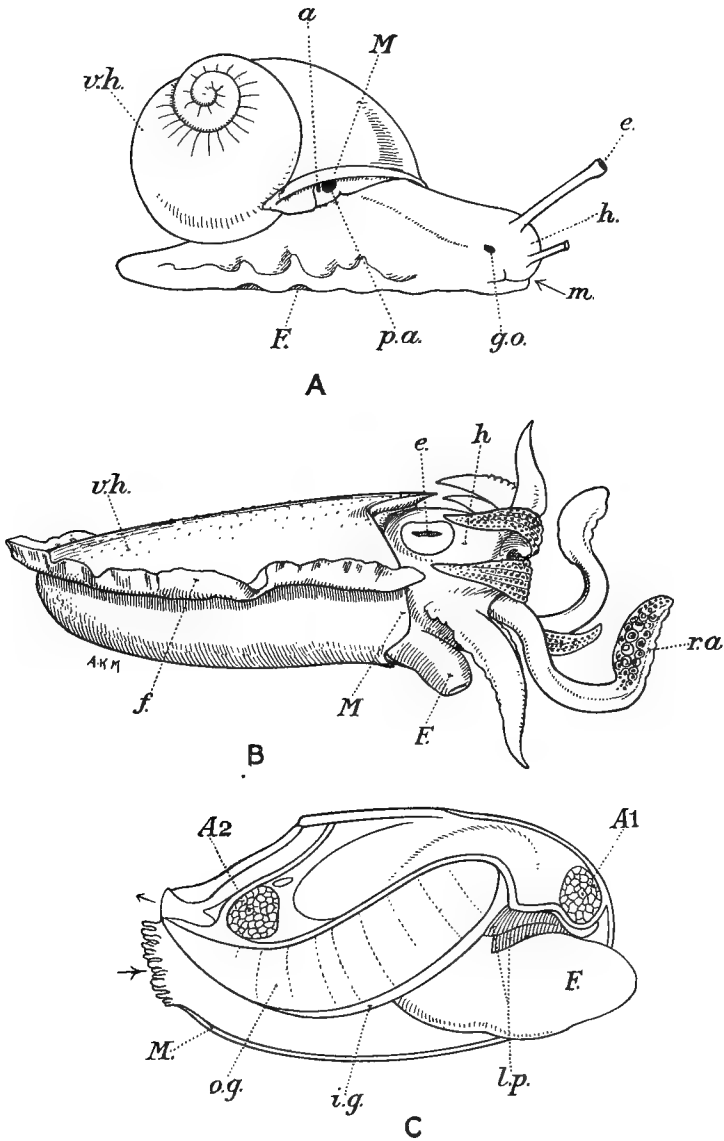

FIG. III.

The three chief types of Mollusc. A, a Gasteropod (*Helix*); B, a Siphonopod (*Sepia*); C, a Pelecypod (*Anodonta*). *A1*, Anterior adductor muscle; *A2*, posterior adductor; *a*, anus; *e*, eye; *F*, foot; *f*, fin; *g.o.*, genital opening; *h*, head; *i.g.*, inner gill; *l.p.*, labial palp; *M*, mantle-flap; *m*, mouth; *o.g.*, outer gill; *p.a.*, pulmonary aperture; *ra*, retractile arm; *vh.*, visceral hump.

the complete cavity of the shell but shrinks back from its apical portion, leaving a space. In the Siphonopoda this has become a fundamental characteristic of the group. These molluscs have become specialized for an active swimming existence and the space between the visceral hump and the apex of the shell becomes filled with gas secreted into it which serves to reduce the specific gravity of the creature to approximately that of the water in which it lives, so that it does not have to expend muscular energy in constant exertion to keep itself from sinking. In most of the existing Siphonopods the shell has become greatly modified and enclosed within the body, as in the spongy Cuttle-bone, as it is called, of the ordinary Cuttlefish (*Sepia*), but the wonderfully archaic Pearly Nautilus (*Nautilus*), which though it dates back to extremely ancient times (Silurian period) still lingers on to the present day in the Indian and Pacific Oceans, shows us what the Siphonopod shell was primitively like. It is a long cone coiled into a flat spiral. During its formation the apex of the visceral hump periodically shrinks back from the shell and then, having come to rest for a time, proceeds to cover itself with a layer of shell which forms as it were a floor to the deserted portion of the shell-cavity. The result is that in the fully developed Nautilus the cavity of the shell consists of a series of chambers separated from one another by the successive floors or partitions (Fig. 112). It is only the last or outermost of these chambers that is filled by the visceral hump. The others are occupied merely by secreted gas, except that a thin prolongation of the visceral hump, called the **siphuncle** (Fig. 112, *s*), is continued through them and the intervening partitions.

In the Pelecypoda (Fig. 111, C) the shell is bivalve. Along the mid-dorsal line the substance of the shell undergoes no calcification but continues throughout its thickness to consist of conchiolin which forms an elastic cushion—the **hinge-ligament**—connecting together the two halves or valves of the shell, lying one to the right and one to the left side of the body. Usually the two valves are approximately equal, but in many Pelecypoda which have adopted a sedentary habit, resting on one side of the body, as does the Oyster, the shell becomes lopsided—the valve that is below being deeper and that which is above flatter.

The region of the dorsal surface which forms the mantle extends normally on to a kind of flap or skirt—the **mantle-flap**—hanging down all round and covering in a recess (the **mantle-cavity** or pallial cavity) in which are situated a set of important features—anus, nephridial openings and gills, together constituting the **pallial complex**. The mantle-cavity is not equally deep all round: it is comparatively shallow except in the neighbourhood of the pallial complex, and this pallial

complex shows interesting differences in position and in the arrangement of its details in the different groups of molluscs. A relatively primitive condition of the pallial complex is seen in the ordinary Siphonopods and, less distinctly, during the young stages of development of ordinary Gasteropods. The deep portion of the mantle-cavity (Fig. 113, A, *m.c.*) lies on the posterior side of the visceral hump and contains the pallial complex which consists of the anus in the centre (*a*), the two nephridial openings one on each side of this (*n*), and beyond the nephridial opening

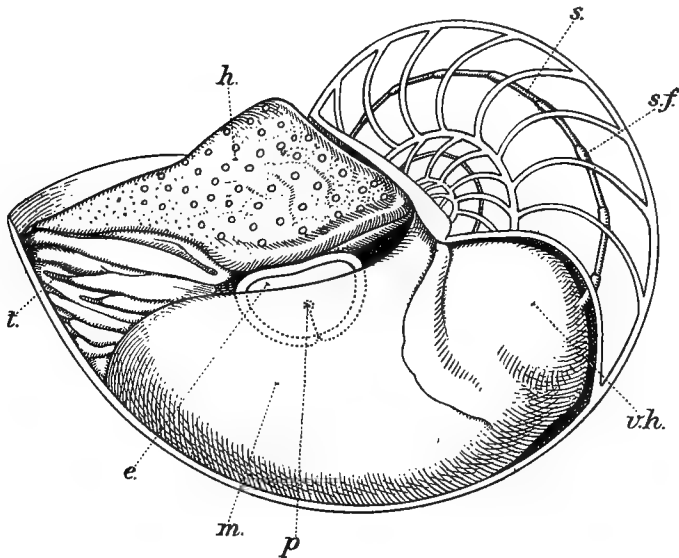

FIG. 112.

Nautilus: the left side of the shell has been removed. *e*, Eye; *h*, hood; *m*, mantle-flap; *p*, pupil; *s*, siphuncle; *s.f.*, siphonal funnel; *t*, tentacle; *v.h.*, visceral hump.

on each side a gill (*ct*). The gill, termed in the Mollusca a **ctenidium**, is a feather-shaped organ, with a central axis carrying on each side thin plate-like outgrowths filled with blood which are the actual breathing organs, and are consequently spoken of as the **respiratory lamellae**.

In the ordinary adult Gasteropod a remarkable change has come over the pallial complex. In order apparently to escape interference by the foot, which is greatly developed and extends back in such a way that it would obstruct the free inflow and outflow of water, the deep part of the mantle-cavity containing the pallial complex has become shifted

forwards round the right side of the body towards the head (Fig. 113, B). The pallial complex is now anterior to the visceral hump and it has

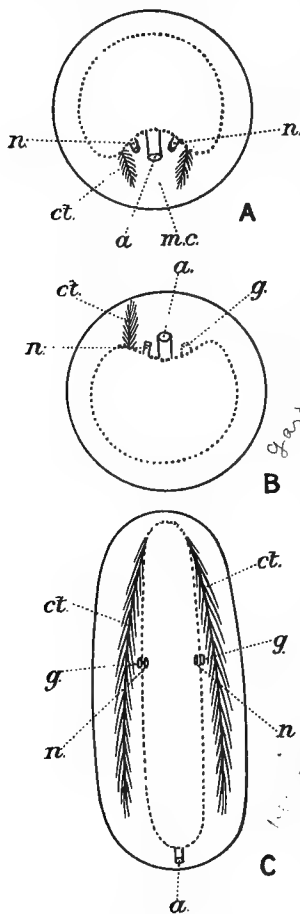

FIG. 113.

Plan of pallial complex as seen from above. A, primitive arrangement; B, Gasteropod; C, Pelecypod. The inner boundary of the mantle-cavity is indicated by a dotted line. *a*, Anus; *ct*, ctenidium; *g*, genital opening; *m.c.*, deep part of mantle-cavity; *n*, nephridium.

become reversed in position, its original right side being now on the left. The pallial complex has also lost its original symmetry, the original left ctenidium having disappeared while the original left nephridium has lost its original function and now serves as the genital duct. The persisting ctenidium (Fig. 113, B, *ct*) also commonly loses its original symmetry, the respiratory lamellae disappearing from its left side so that it takes the shape of a comb rather than that of a feather. In some of the more familiar Gasteropods—the snails and slugs—which have taken to breathing air, the deep part of the mantle-cavity functions as a lung. Its original opening to the exterior has been narrowed down to a small round hole on the right side (Fig. 111, A, *p.a*); the ctenidium has disappeared and its respiratory function has been taken over by a rich network of blood-vessels developed over the inner surface of the mantle. In some of our marine Gasteropods living between tide-marks such as the common little Periwinkles or “Wilks” (*Littorina*) the first steps in a similar evolution may be seen, for although the ctenidium is still present and functional a rich network of blood-vessels for aerial respiration has developed in its neighbourhood.

In the Pelecypoda, while the pallial complex retains its primitive symmetry, it has become much changed in other respects through the great modification of the ctenidium. The Pelecypoda are molluscs which have given up active browsing or predatory habits and have taken to subsisting on minute particles of food material floating in the water such as bacteria

and other microscopic vegetable or animal organisms. Further they are commonly burrowing in their habits. For both of these reasons they require special arrangements whereby supplies of water can be drawn through the body. Such an arrangement is provided by the ctenidia which have become modified in a characteristic fashion, well seen in an ordinary marine mussel (*Mytilus*). In the first place the ctenidium has become greatly enlarged and its basis of attachment has been shifted forwards to a point near the front end of the body (Fig. 113, C), the ctenidium extending back along the side of the body: in correlation with this alteration in size and position of the ctenidium the deep portion of the mantle-cavity containing it is now paired and lateral in position, being covered in by the large mantle-flap lining the valve of the shell. In the second place the axis of the ctenidium, instead of hanging freely, has become laid up against the roof of the mantle-cavity and completely fused with it, so as to form a longitudinal ridge from which hang down the "respiratory lamellae." In the third place these last-named structures are no longer correctly described as "lamellae," for each one has become lengthened out into a fine filament. From the axis of each ctenidium there hang down into the mantle-cavity two rows, an inner and an outer, of these respiratory filaments, each one bent upon itself into a V-shape. The filaments are richly ciliated and hang down parallel to one another and in close apposition, the ciliary movement being such as to draw a constant stream of water from the mantle-cavity, through the narrow slits between adjacent filaments, into the cavity enclosed by the descending and ascending portions of the filaments, whence it passes out to the exterior at the hind end of the mantle-cavity. In the ordinary mussel the filaments are not merely in close proximity: they are held in position by remarkable arrangements known as **ciliary brushes**. Here and there, facing one another at adjoining positions on two neighbouring filaments, is a patch of stout long stiffish cilia which have to a great extent lost their power of movement. When two such patches come in contact the cilia show slight movement which causes the two sets of cilia to become insinuated in amongst one another so that they interlock and are held together like the bristles of two brushes which have been knocked together. The result is that the ctenidium in the undisturbed position has the appearance of two plate-like structures (Fig. 111, C), an inner (*i.g.*) and an outer (*o.g.*), formed of the inner and outer row of V's respectively—an appearance which finds expression in the technical name Lamellibranchiata frequently used instead of Pelecypoda. In *Mytilus* the plate-like arrangement is readily disturbed, the plates falling apart into their constituent filaments,

but in the majority of Pelecypoda this is not so, for the ciliary brushes have become replaced by bridges of solid tissue which knit the filaments together into a permanent palisade or lattice-work.

The large mantle-flaps which hang down on each side of the Pelecypod meet along their ventral edges when the shell is closed. Commonly there is present at the posterior end of the creature a space between the two mantle-flaps, divided more or less distinctly into two parts, a ventral and a dorsal: these serve respectively for the indraught of water into the mantle-cavity caused by the ciliary movement of the gills and for its exit, and are hence known as the **inhalent** and **exhalent** openings (Fig. 111, C, *i* and *e*). When these openings are, as is frequently the case, demarcated by complete fusions of the mantle-edges their lips may be prolonged into tubular **siphons**. These siphons—inhalent and exhalent—vary greatly within the group, in their length which may be relatively enormous as in *Teredo*—the “Ship-worm”—whose burrows, often seen in bits of timber washed up on the shore, are traversed throughout their length by the siphons, and in the degree to which the two siphons are independent or on the other hand fused together throughout a less or greater extent of their length.

The foot is seen in what is probably its primitive form in the Gasteropoda (Fig. 111, A, *F*) where it forms a flat creeping sole such as may be seen in the case of an ordinary snail or limpet. In the Pelecypoda the flat sole has been lost except in a few of the most archaic and the lower boundary of the foot is now a blunt edge while the outline as seen from the side is somewhat like that of a ploughshare (Fig. 111, C, *F*). This type of foot is in fact used for ploughing through sand or mud, the Pelecypod type of mollusc being specialized for a burrowing existence. In the most primitive Siphonopod—*Nautilus*—the foot has become tongue-shaped and is rolled on itself, one edge overlapping the other so as to form a funnel-shaped **siphon**. In the ordinary Siphonopods the inrolled edges become in the course of development completely fused together so as to make the funnel completely tubular (Fig. 111, B, *F*). The wide inner end of the funnel lies within the deep part of the mantle-cavity, the mantle-flap fitting round it, and in the typical Siphonopods being temporarily fixed to it by special fasteners. The mantle-flap is muscular and the Cuttlefish is able to make it contract suddenly so as to force the water contained in the mantle-cavity outwards through the siphon in the form of a sudden jet, and cause the animal to shoot violently back through the water.

As regards the alimentary canal the most characteristic and peculiar feature is a curious tongue-like organ present in the pharynx of Gastero-

pods and Siphonopods and capable of being protruded at the mouth and used for rasping off food material. The surface of the tongue is covered with a ribbon of conchiolin, known as the **radula**, the surface of which carries numerous tooth-like spines arranged in transverse rows. The character, grouping, and numbers of the teeth in each row differ in different groups of the molluscs in question, and in the case of the Gasteropoda the **radular formula**—an arrangement of figures expressing the number and grouping of the teeth—is made use of in defining the characteristics of the various subdivisions of the group. These radulae when dissected out and freed from adhering soft tissues with the aid of caustic potash make interesting microscopic preparations. The teeth at the front end of the radula gradually become worn down and ineffective through use and special arrangement exists to compensate for this. At its hinder end the radula is continued along the floor of the **radular sac**—a blindly ending extension backwards of the floor of the pharynx. At the hind end of this active formation of cuticle is constantly going on by which the radula is there added to. As this new formation goes on the radula is gradually paid out by the radular sac, travelling forwards over the surface of the tongue at a rate just sufficient to make up for the wearing away in front. In the Pelecypoda—in correlation with their feeding on minute floating particles—the radula has completely disappeared. The food particles are drawn into the mantle-cavity in the inhalent current caused by the ciliary movements of the gills, and they are then collected and driven into the mouth by special organs known by the somewhat misleading name **labial palps** (Fig. 111, C, *l.p.*). The large crescentic mouth is bounded by a dorsal and a ventral lip which in the middle hardly projects at all but which towards each end increases in depth till it forms a large triangular flap. The dorsal and ventral flap on each side are closely apposed to one another: on their apposed surfaces are richly ciliated channels which lead towards the mouth opening, and in these a current of water, laden with food particles, passes inwards to the mouth. In the most archaic group of Pelecypoda—the Protobranchiata (so called from their retaining in an unmodified form the primitive feathery ctenidium)—the two apposed labial palps on each side have become lengthened out to form a tube which can be protruded far beyond the limits of the mantle-cavity and worked over the surface of the sand, drawing in food-particles after the fashion of a minute vacuum-cleaner.

The alimentary canal of the mollusc forms a long tube which winds about and is more or less distinctly dilated to form a stomach into which there open the ducts of a pair of large digestive glands—the so-called

liver. Typically in the Pelecypoda and in some of the more primitive Gasteropods there is formed in a glandular recess of the stomach, or commencement of the intestine, a curious glassy-looking body—the **crystalline style**—apparently a condensed mass of digestive ferment and of practical interest as being the haunt of the large Spirochaetes mentioned on p. 77. In the typical Cuttlefishes there opens into the intestine close to the anus a very large gland—the **ink-sac**—which secretes the dark brown pigment known to artists as sepia. When alarmed the Cuttlefish allows some of the secretion to pass into the mantle-cavity, whence it is blown out through the siphon as an opaque cloud behind which the creature is able to escape unseen.

The body-cavity of the mollusc like that of the arthropod is haemocoelic in its nature—a large part of the blood system having degenerated into a system of irregular spaces filled with blood and traversed by a sparse spongework—the remnants of the vessel walls and other solid tissues.

The coelome has become reduced to two relatively small cavities—the **pericardiac cavity** which surrounds the heart and in the more primitive molluscs is still traversed by a small part of the intestine, and the **genital coelome**—the cavity of the ovary or testis.

There is some reason to believe that primitively each of these cavities communicated with the exterior by a pair of tubular nephridia, but in the course of the evolution of the Mollusca these nephridia have undergone extensive modification. Those originally belonging to the genital coelome have completely disappeared except in *Nautilus* and in some of the more primitive Gasteropods (*Chiton*), in which they function as genital ducts. On the other hand the right nephridium associated with the pericardiac coelome establishes a connexion with the ovary or testis in some of the lower Gasteropods and serves for the exit of the reproductive cells, while in the more highly evolved members of the group it loses its original connexion with the pericardiac cavity and becomes simply the genital duct. In the Pelecypoda it would appear, judging from the more primitive forms (Protobranchia), that both nephridia leading from the pericardiac cavity once served as genital ducts. In the majority of existing Pelecypods, however, the opening from the ovary or testis has been shifted outwards along the course of the nephridium until it now lies outside the nephridium altogether on the external surface of the body.

The molluscan nervous system shows a particularly characteristic arrangement in the ordinary Gasteropods. Here (Fig. 114, A) there are three pairs of large ganglia clustered round the oesophagus—the **cerebral**

or supra-oesophageal dorsal in position (*c*), the **pedal** ventral (*p*), and the **pleural** somewhat lateral (*pl*). Uniting these ganglia are commissures, cerebral, pedal, cerebro-pedal, cerebro-pleural, and pleuro-pedal. Further there is a long pleural commissure—the **visceral loop** (*v.l.*)—on the course of which there are typically three smaller ganglia—a **visceral** and two **parietal**. An important point to notice is that each of the latter is linked on to the ctenidium of its side by a small nerve passing to it from the **osphradium**—a special sense organ situated at the base of the ctenidium. Connected with all the ganglia that have been mentioned are peripheral nerves uniting them with the regions of the body which they innervate. Thus the cerebral ganglia are linked up with the organs of the head, the pedal with the foot, and the pleural with the mantle.

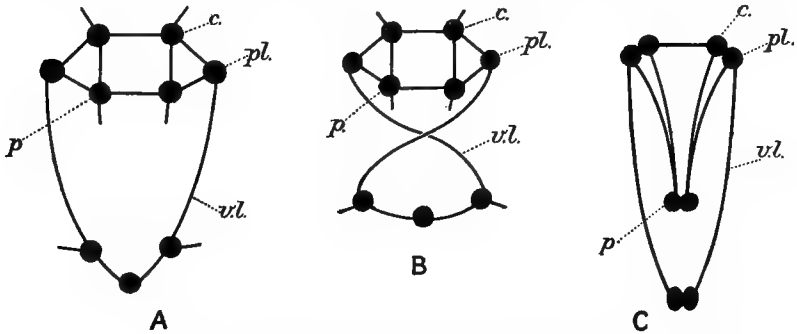

FIG. 114.

The central nervous system of Mollusca. *A*, Gastropod (euryneurous); *B*, Gastropod (streptoneurous); *C*, Pelecypod. *c*, Cerebral (supra-oesophageal) ganglion; *p*, pedal ganglion; *pl*, pleural ganglion; *v.l.*, visceral loop.

A typical nervous system such as the above is well seen in one of the ordinary fresh-water snails (*Limnaea*)—air-breathing Pulmonates which have taken to an aquatic existence—except that in them the visceral loop is quite short so that the visceral and parietal ganglia lie close to the other ganglia. In the majority of gastropods the visceral loop is long and the nerve joining the parietal ganglion to its osphradium being relatively short the parietal ganglion attached to the originally right ctenidium has had to accompany this ctenidium in its shifting during the rotation of the visceral hump. The result is that the originally right parietal ganglion is now on the left, and that the originally right half of the visceral loop has been carried over the left half in X-shaped fashion (Fig. 114, *B*). This is the twisted or **streptoneurous** condition of the visceral loop which is contrasted with the primitive untwisted or **euryneurous** condition. Streptoneury occurs as stated in

the great majority of gasteropods. Euthyneury is found in the Pulmonata in which the loop is too short to be twisted and it is also found in an interesting group of gasteropods—the Opisthobranchiata—in which the pallial complex has become shifted backwards again along the right side of the body so that the loop has been untwisted.

While the above-described condition of the nervous system with its distinct ganglia is found in the majority of existing gasteropods it is probably not primitive. In the Mollusca as in other groups the evolution of the nervous system has been marked by gradually increasing concentration from a primitive more diffuse condition, and in fact when we examine the most primitive gasteropods such as *Chiton* we find the central nervous system consisting of broad strands with ganglion cells scattered over their surface instead of being concentrated into definite ganglia. In the Pelecypoda (Fig. 114, C) there is usually a set of ganglia resembling that of a Euthyneurous gasteropod except that the cerebral and pleural ganglion on each side are fused into a single ganglionic mass. Of the Siphonopods the most primitive, *Nautilus*, has a nervous system of broad strands like those of *Chiton*, while the others have their ganglion cells concentrated into rounded ganglionic masses resembling somewhat though less distinct than those of Gasteropods.

The molluscs have, except in the region of the shell, soft sensitive skins with scattered sensory cells. In addition they have masses of sensory cells concentrated together to form definite sense organs—eyes, otocysts, osphradia. Of these the eyes are of special interest, for whereas some members of the phylum—the Cuttlefishes—possess eyes which are amongst the most complicated and most highly developed known, others such as the ordinary Limpet (*Patella*) possess eyes in the very earliest stages of evolution. Either the comparative study of the structure of the eye in the adults of different molluscs, or on the other hand the study of the various stages in the embryonic development of one of the more complicated eyes like that of the Cuttlefish, serves to give us a wonderfully clear and complete picture of how these organs have gradually become perfected in the course of evolution.

In the Limpet (Fig. 115, A, 1), the eye consists of a localized thickening of the epidermis (the retina) containing numerous slender sensory cells sensitive to light and continued at their inner ends into nerve fibres: this sensory thickening of the epidermis dips down below the surface in the form of an open pocket. In the "Silver Willie" (*Trochus*—Fig. 115, A, 2) the eye shows a slight evolutionary advance, the pocket being in this case distended to form a hollow vesicle, with a narrow opening

to the exterior, and filled by a clear mass of transparent jelly-like secretion—the vitreous body (*v*). In *Murex* (Fig. 115, A, 3) a further advance has been made—the cavity of the vesicle being now completely shut off from the exterior. The interior of the vesicle is filled with homogeneous vitreous substance but a large rounded portion towards the external surface is marked off from the rest by its greater density so as to form a lens (*l*).

Study of the successive stages in the development of the more complicated eye of the Cuttlefish (Siphonopoda) provides a corresponding

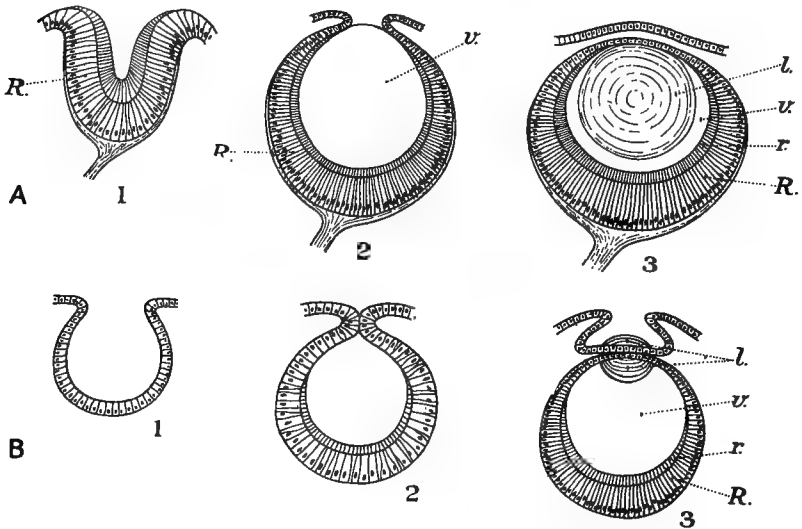

FIG. 115.

The evolution of the eye in Molluscs as illustrated by comparative anatomy (A) and embryology (B). A1, *Patella*; A2, *Trochus*; A3, *Murex*. B1, 2, 3, stages in development of the eye of a Siphonopod. *l*, Lens; *R*, retina; *r*, rod; *v*, vitreous body.

record of its evolution. In an early stage the eye is in the form of a simple depression of the epidermis (Fig. 115, B, 1); in later stages the opening of this depression becomes gradually narrowed, and its cavity becomes filled with vitreous secretion (Fig. 115, B, 2); finally the eye forms a completely closed vesicle (Fig. 115, B, 3). In most Siphonopods the eye does not remain in this *Murex*-like stage but proceeds to further complications which need not be detailed here but which culminate in a degree of complexity similar to that of the eye of the higher vertebrates. It is remarkable that in *Nautilus*, the most archaic of existing Siphonopods, the eye remains throughout life in a stage intermediate between

those of Fig. 115, B, 1 and 2. The retina here lines a deep cavity communicating with the exterior by a minute pore (Fig. 112, *p*).

In the simpler of these types of molluscan eye there can be no question of vision in the ordinary sense of the term—they distinguish merely between light and shade. The rounded mass of vitreous body serves in the first instance merely to render the eye more sensitive by concentrating the light upon the retina, but with the development of a lens the formation of an image becomes possible and an incipient capacity for short-sighted vision is acquired (Land-snails). In *Nautilus* the small opening takes the place of a lens, as in a "pin-hole camera," rendering possible a picture of surrounding objects. And finally the highly complicated eye of the typical Cuttlefish provides for a highly developed sense of sight with power of accommodating the vision to objects at varying distances. As in the case of a fish the eye is normally focused for objects near at hand but special muscles are present whereby the lens can be drawn closer to the retina so as to focus more distant objects.

The molluscs with the rarest exceptions (*Chiton* and its allies) possess a pair of otocysts, associated as in other cases with the balancing of the body in relation to gravity. As elsewhere each otocyst is formed from a sensory thickening of the ectoderm which sinks below the general surface and, except in the most archaic Pelecypoda, loses its communication with the exterior. As a rule the otocysts are situated close to the pedal ganglia but as their nerve-fibres have been traced to the cerebral ganglia it would appear that they belonged originally to the head region and have become secondarily shifted into that of the foot, retaining their primitive nervous connexion with the ganglia of the head region.

The last type of molluscan sense-organ is the **osphradium**—a patch of sensory epithelium in the neighbourhood of the ctenidium. It is believed to have to do with testing the water that bathes the surface of the ctenidium but the exact nature of this function is quite obscure. The osphradium is best seen in the Gasteropoda where it is connected by nerve-fibres with the visceral loop.

While the Mollusca are typically marine animals, a considerable number of Pelecypoda and Gasteropoda have taken up their abode in fresh water and a number of Gasteropods (Snails and Slugs) have become terrestrial. Some of these latter have in turn reverted to the aquatic habit (Water-snails), retaining however for the most part their terrestrial habit of breathing air by means of their lung.

The chief direct interest of the Mollusca to medicine centres in the pelecypodan habit of drawing into the body minute floating particles. Disease-producing bacteria such as Typhoid bacilli drawn into the body

are apt to remain alive in it and to accumulate, if they are numerous in the water. Oysters, Mussels, and other edible Pelecypoda living in waters polluted by drainage containing such disease germs are consequently liable to be a source of serious danger to persons eating them in an uncooked condition. If kept in pure sea-water the molluscs soon lose their infectivity.

BOOK FOR FURTHER STUDY

Sedgwick. A Student's Text-book of Zoology, Vol. I.

CHAPTER VIII

ECHINODERMATA

SCHEME OF CLASSIFICATION

- I. ASTEROIDEA—Starfish.
- II. OPHIUROIDEA—Brittle-stars.
- III. ECHINOIDEA—Sea-urchins.
- IV. HOLOTHUROIDEA—Sea-cucumbers, Trepangs.
- V. CRINOIDEA—Crinoids, Encrinites.

THIS phylum is one which seems to lie quite off the main track of the evolution of the animal kingdom: it is of comparatively little economic or medical importance and it might justifiably be omitted from such a text-book as this. The group, however, contains creatures, such as Starfish and Sea-urchins, which are familiar objects of the sea-side, and it is further of such interest both morphologically and physiologically as to make at least an outline sketch desirable. Material for such an outline is provided by the common starfish (*Asterias*, Fig. 116, A), which is easily obtained and easily dissected.

The most conspicuous feature of the starfish is that which gives it its name—its radiate symmetry—five **arms** projecting outwards from a central portion or **disc**. There are two distinct surfaces, a lower or **oral** surface with the mouth in its centre, and an upper **aboral** or **apical** surface with the very minute anus (Fig. 116, A, *a*) near its centre. From the mouth there passes outwards along the oral surface of each arm a deep groove—the **ambulacral groove**—from which there project numerous little cylindrical semi-transparent **tube-feet** (*t.f*), each with a round sucker at its end, by the co-ordinated movement of which the starfish is able to draw itself slowly along a solid surface. The region bearing the tube-feet, which in other Echinoderms need not necessarily have the form of a groove as it has in the starfish, is termed an **ambulaerum** and from this

the portion of surface on which they are present—in the starfish the oral surface—is termed the **ambulacral surface** as opposed to the **abambulacral** surface on which tube-feet are absent.

The features mentioned so far may be observed in any species of starfish—except that the number of rays though usually five is in a few cases greater: they are in fact characteristic of the Asterozoa in general. The other subdivisions of the Echinodermata have characteristic differences. Thus in the Ophiuroids (Fig. 116, B) and the Crinoids (Fig. 116, E) the rays are more distinctly marked off from the disc: the Crinoids are typically attached to the substratum by a long slender **stalk** (*s*) which projects from the centre of their apical surface: the Echinoids (Fig. 116, C) and Holothurians (Fig. 116, D) have lost their star shape and become

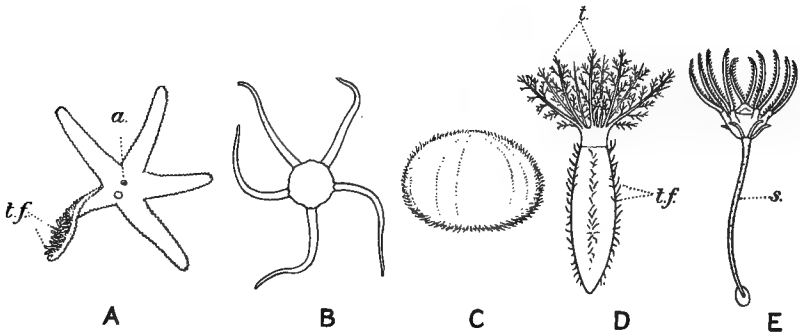

FIG. 116.

The chief types of Echinoderm. A, A Starfish; B, a Brittle-star; C, a Sea-urchin; D, a Holothurian; E, a Crinoid. *a*, Anus; *s*, stalk; *t*, oral tube-feet; *t.f.*, tube-feet.

rounded or elongated—the rays being as it were withdrawn into the disc—and the abambulacral surface has shrunk away almost to nothing, the ambulacra stretching from the mouth right up to the neighbourhood of the apical pole.

A characteristic feature of the Echinoderm is its skeleton. In the Starfish this is in the form of plates and bars (“ossicles”) of calcium carbonate embedded in the body-wall. On the abambulacral surface these form an irregular network: on the oral surface they are arranged more regularly especially in the region of the ambulacral groove over which they—the **ambulacral ossicles**—are arranged like the rafters of a roof. Scattered over the surface—though not so well marked in *Asterias* as in many other Echinoderms—are ossicles which project outwards as **spines**—hence the name Echinodermata, i.e. spiny skinned. Some of these spines have undergone an interesting modification, having

become grouped in pairs and possessing muscles so arranged that the two spines can be pulled together and function as minute forceps or pincers. These organs—the **pedicellariae**—may be seen in large numbers along the edge of the ambulacral groove and again, forming rounded clumps, round the base of the ordinary spines. Their function appears to be to keep the surface of the starfish free from foreign particles, minute animals, etc. : they clutch these readily and pass them on.

In the other groups of Echinoderms we find characteristic differences in the skeleton. In the Ophiuroids, Crinoids, and Echinoids, it is more highly developed than in the Asteroids. In the Ophiuroids the ambulacral ossicles have become converted into compact “vertebrae” which occupy a great part of the thickness of the arm and are jointed together so as to form a chain freely flexible in a horizontal plane, by the movements of which the Ophiuroid pushes itself along. To bring about these movements strong muscles pass on each side from one vertebra to the next, and if removed from the water the Ophiuroid is apt to go through a characteristic performance, contracting the muscles on both sides of the arms at once with the result that they rupture and the arms drop apart into numerous fragments, thus justifying the English name Brittlestar. In the Crinoid the stalk is composed for the most part of pentagonal or circular skeletal blocks arranged in a row. While at the present time only a few genera and species of Crinoids survive, they flourished exceedingly during earlier geological periods (Carboniferous, Liassic), attaining to a great size and to great numbers both of species and individuals : their stalk ossicles are amongst the most familiar of fossils in the limestones of these ages.

In the Echinoids the ossicles are large plates closely jointed together, forming the well-known **test** or shell of the Sea-urchin. During life the plates of the test though apparently fitting together edge to edge are really separated by a thin layer of living tissue, this arrangement rendering possible the growth of the individual plates along their edges and as a consequence the increase in size of the test as a whole. In the Echinoids the spines are greatly developed, being long and usually slender, and in correlation with this both tube-feet and pedicellariae are correspondingly lengthened.

In contrast with the groups mentioned the Holothurians show a greatly reduced condition of the skeleton, the individual plates in the body-wall being reduced to minute spicules—sometimes of beautiful and characteristic shape—and thus the body-wall instead of being rigid is flexible, of a tough leathery consistency.

The alimentary canal of the starfish is comparatively short, passing

straight from mouth to anus, but it shows an unusual degree of differentiation. The mouth leads into a large baggy portion (Fig. 117, *s*), usually called the stomach, which is capable of being pushed out at the mouth and wrapped round the mollusc which serves the starfish as food.

The stomach leads into a flattened pentagonal **pyloric sac** (Fig. 117, *p.s*) each angle of which is continued as a tubular prolongation into the arm and bifurcates to form two large glandular caeca (Figs. 117 and 118, *p.c*), extending nearly to the tip of the arm. These secrete digestive ferment which passes into the pyloric sac. From the pyloric sac there passes to the anus the very short intestine (Fig. 117, *int*) and the wall of this bulges outwards to form two irregular **rectal caeca** (*r*)—apparently also

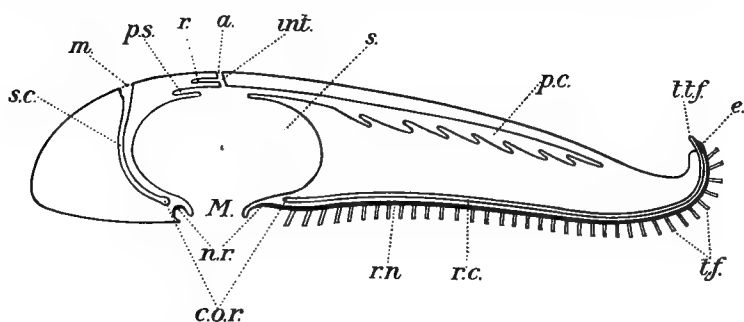

FIG. 117.

Vertical section through a starfish. *a*, Anus; *c.o.r.*, circum-oral ring of hydrocoele; *e*, eye; *int.*, intestine; *M*, mouth; *m.*, madreporite; *n.r.*, circum-oral nerve ring; *p.c.*, pyloric caecum; *p.s.*, pyloric sac; *r.*, rectal caecum; *r.c.*, radial canal of hydrocoele; *r.n.*, radial nerve; *s.*, stomach; *s.c.*, stone canal; *t.f.*, tube-feet; *t.t.f.*, terminal tube-foot bearing eye at its base.

glandular in function. In *Asterias*, as already indicated, the anal opening (*a*) is very small: in some other starfishes it has disappeared altogether, and in the group of Ophiuroids this has become the normal condition—the alimentary canal being reduced to the stomach into which the mouth opening leads. In the other groups of Echinoderms the alimentary canal, while showing less marked division into different parts than in the Asteroids, has become elongated and tubular in form. In the typical Echinoids a new complication has made its appearance in the development of five powerful teeth, meeting in the centre of the mouth and provided with a very complicated arrangement of skeletal structures described long ago by Aristotle and called by him the “lantern” of the Sea-urchin. It is still commonly spoken of as “Aristotle’s lantern.”

A characteristic feature of the Echinoderms is the extremely complicated subdivision of the coelomic cavity. In the primitive condition the arrangement is simple, three pairs of coelomic sacs being budded off the endoderm, but in the adult these have undergone curious lop-sided developments in adaptation to the radial symmetry of the body so that the original simple paired arrangement has become completely unrecognizable.

The formation of gonad is restricted to a single one of the coelomic cavities, which takes on the form of a ring round the anus and sprouts out into ten radiating tubes towards the bases of the arms. The gonad is in the form of a thickening of the epithelium which extends along the various portions of the genital coelome. The gonad never becomes functional except at the tips of the ten radiating canals already mentioned, at each of which it swells up to form a much lobed testis in the male or ovary in the female. As it matures the ovary or testis sprouts out towards the surface and develops an opening to the outside at the base of the arm through which the eggs or sperms pass out. In an ordinary dissection the functional ovaries or testes are conspicuous, but all the rest of the gonad and the cavities associated with it can only be worked out by the examination of microscopic sections.

The most remarkable development of the coelome is what is called the **hydrocoele**—sometimes still called by the old name “water-vascular system”—which has to do functionally with the movement of the tube-feet. The hydrocoele of the fully developed starfish consists of the following parts. Round the mouth opening there is a somewhat pentagonal **circum-oral ring** prolonged along each arm as a **radial canal** (Figs. 117 and 118, *r.c.*). From the radial canal pass off numerous side branches each of which communicates with a tube-foot and where it does so is guarded by a valve that allows fluid to pass towards the tube-foot but not in the opposite direction. The tube-foot (Figs. 117 and 118, *t.f.*) is almost cylindrical in form and terminates in a sucking disc: its walls are comparatively thin and contain muscle fibres which run in a longitudinal direction. At its inner end the tube-foot is continued into a round bulb—the **ampulla** (Fig. 118, *a*)—which projects into the main coelomic cavity of the arm. The ampulla possesses in its wall circular muscle fibres by which it can be compressed.

The functioning of the tube-foot takes place as follows. The muscles of the ampulla contract and the coelomic fluid contained in it is forced into the tube-foot which is consequently pushed out. On its tip coming into contact with a solid object special muscle fibres in the terminal disc contract and cause it to take a cup shape so that it adheres to the solid

object. The longitudinal fibres in the wall of the tube-foot then contract so that it shortens and pulls the body of the starfish towards the point of attachment.

For the efficient working of the tube-feet it is clearly necessary that the hydrocoele should be distended with fluid: but it is also clear that, the walls of the tube-feet and ampulla being comparatively thin, a certain amount of loss of fluid must take place by a process of filtration through them. A special mechanism is therefore necessary to compensate for this loss of fluid. On the aboral surface of the starfish and situated

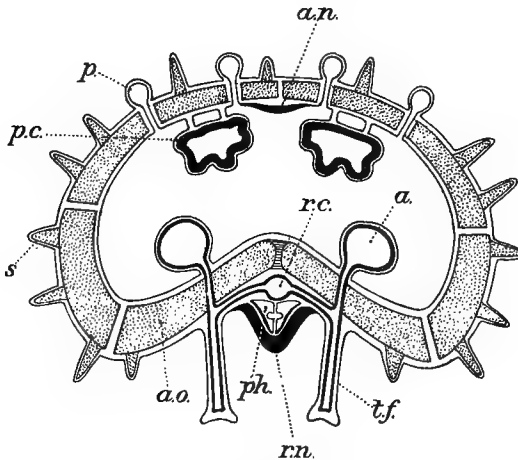

FIG. 118.

Transverse section through arm of a starfish. (Simplified from Lang.) *a*, Ampulla; *a.n.*, aboral (apical) nerve; *a.o.*, ambulacral ossicle; *p*, papula (gill); *p.c.*, pyloric caecum; *ph.*, periaermal space; *r.c.*, radial canal of hydrocoele; *r.n.*, radial nerve; *s*, spine; *t.f.*, tube-foot.

interradially—i.e. in the angle between the axes of two adjacent arms—is a conspicuous ossicle (Figs. 116, A, and 117, *m*), its surface indented by meandering grooves dotted along the bottom of which are minute pores. This ossicle is the **madreporite**. From its under side there passes downwards to the circum-oral ring of the hydrocoele a tube (Fig. 117, *s.c.*) known as the **stone-canal** from the fact that its walls are so infiltrated with calcium carbonate as to have a hard stony consistency. This stone-canal is lined with epithelium carrying powerful cilia or flagella, the beating of which causes a slow downward current—water being drawn in by the pores of the madreporite and propelled onwards to the ring canal and thence to the rest of the hydrocoele to make up for the loss of fluid.

The fluid of the hydrocoele is, as will have been gathered, nearly pure sea water, but it is inhabited by amoebocytes which are budded off into it by nine little pockets of the inner wall of the circum-oral ring known as **Tiedemann's bodies**: these are arranged in pairs between each two rays except that the stone-canal occupies the position of one of them. No doubt the fluid, in addition to the amoebocytes, receives various chemical products of the metabolism of the surrounding tissues.

In other Echinoderms we find a hydrocoele of the same general type as that of *Asterias* while differing in details. Thus the circum-oral ring has often attached to it—even amongst Asteroids—five “Polian vesicles” looking like large ampullae. In Holothurians (Fig. 116, D) the tube-feet tend to degenerate over most of the body but a circle round the mouth are greatly enlarged, and in some cases branched in a tree-like fashion (Fig. 116, D, *t*): they are used for collecting food and passing it in to the mouth.

The nervous system of the Echinoderms is on the whole remarkable for its very primitive character. Towards the inner surface of the soft ectoderm there exists a diffuse nervous network like that of a coelenterate which serves to link together the various parts of the surface into a coherent whole. In a Sea-urchin it is easy by rotating a cork-borer or apple-corer against the hard test to make a circular break in the continuity of the network and then it is seen that the spines within the isolated area no longer move in co-ordination with those outside it. Special concentrations of the network, constituting an incipient central nervous system, form a circum-oral nerve ring (Fig. 117, *n.r.*) and a radial nerve (Fig. 117, *r.n.*) running out from this along each ambulacrum. This central nervous system can easily be displayed in a starfish by pressing apart the tube-feet from the centre towards each side of the ambulacral groove and then scraping them off. By examining a thin transverse section of the arm through a microscope it is seen clearly that the central nervous strands are simply ectodermal thickenings and that they retain their primitive superficial position (Fig. 118, *r.n.*).

In other Echinoderms, except the Crinoids, the nerve strands lose the superficial position. What corresponds to the ambulacral groove becomes as it were closed in and converted into the **epineural space** and the nerve strand is found on the roof or inner wall of this.

A remarkable peculiarity of Echinoderms is that in addition to the ordinary nervous system derived from the ectoderm they possess an accessory one developed from the coelomic lining. In the transverse section through the arm of *Asterias* (Fig. 118) there are seen between the ectodermal radial nerve on the one hand and the radial canal of the

hydrocoele on the other a pair of coelomic canals known as the **perihæmal spaces** (*ph*), somewhat triangular in section and separated by a vertical partition. The floor of each of these, which lies in contact with the radial ectodermal nerve, is thickened and each of these thickenings is a coelomic nerve strand (*c.n*). As they approach the mouth the two perihæmal spaces with their nerve strands diverge from one another and are continued into those of the neighbouring arm. In addition to these the lining of the main coelome of the arm is thickened along its aboral line and this thickening is also partly nervous though not entirely so, part of it being formed of longitudinal muscle fibres which serve to bend

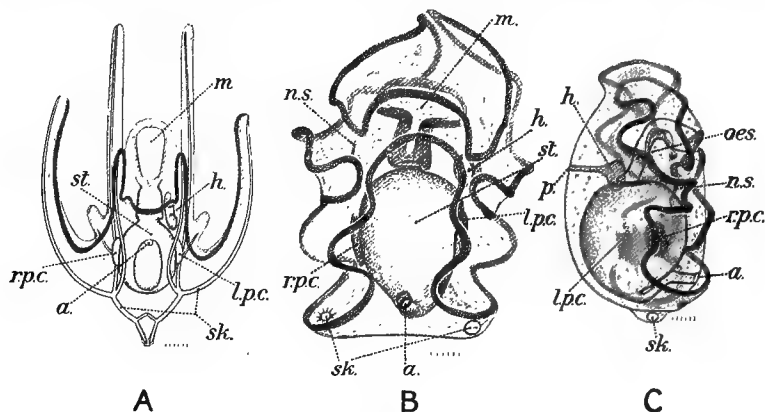

FIG. 119.

Echinoderm larvae. A, Brittle-star (*Ophiura albida*); B and C, Holothurian (*Synapta*). A and B are seen from the ventral side, C from the right side. The scales show hundredths of a millimetre. *a*, Anus; *h*, hydrocoele; *l.p.c.*, left posterior coelome; *m*, mouth; *n.s.*, nervous system; *oes*, oesophagus; *p*, external opening of hydrocoele; *r.p.c.*, right posterior coelome; *sk*, skeleton; *st*, stomach. The band of cilia is shown in dark tone.

up the end of the arm as in Fig. 117. In the Crinoids this ("apical") portion of the coelomic nervous system is greatly developed and controls the movements of the arms.

The Echinoderms show a very slight development of special sense-organs. In the starfish there are present only eyes, of comparatively simple structure, one at the tip of each arm, upon the swollen base of the single tube-foot in which the hydrocoele ends (Fig. 117, *t.t.f*). The eye shows in the living starfish as a bright orange-red spot which is exposed to view owing to the tip of the arm being tilted upwards through the action of the muscle already mentioned. Although the eyes are the only definite organs of sense there are present numerous ordinary sensory

cells scattered through the ectoderm and particularly abundant on the tube-feet, all of which may be said to function as simple sensory organs.

The Echinoderms are typically radially symmetrical, and as radial symmetry is a characteristic of animals that are sedentary or at least not in the habit of moving actively in one particular direction we may assume with considerable probability that the various Echinoderms as we now know them have evolved out of ancestors sedentary in habit as is the case still with the great majority of Crinoids. In studying the development of the Echinoderms we find however that the great majority pass through a larval stage in which they swim freely and, in correlation with this, show a temporary bilateral symmetry.

These Echinoderm larvae while showing certain resemblances to the trochosphere of Annelids exhibit conspicuous peculiarities of their own. The most striking of these is the localization of the cilia on the surface of the body into a band which undergoes a great increase in length either by assuming a tortuous course over the surface of the body as in the Holothurian larva shown in Fig. 119, B and C, or by being carried out on slender prolongations of the body as in the Ophiuroid larva shown in Fig. 119, A. The precise modifications differ in the different subdivisions of the phylum, the end result being a set of larval forms of very characteristic shape and, especially when seen alive, of great beauty. Such Echinoderm larvae exist in great swarms during summer and autumn in quiet inlets of the sea such as the sea-lochs of Western Scotland, and they are easily collected by dragging slowly through the surface waters a tow-net of fine muslin or silk-gauze of the kind used for sifting flour.

BOOK FOR FURTHER STUDY

Sedgwick. A Student's Text-Book of Zoology, Vol. III.

CHAPTER IX

INTRODUCTION TO THE VERTEBRATA: DESCRIPTION OF THE DOGFISH AS ILLUSTRATING THE GENERAL STRUCTURE OF A VERTEBRATE

SCHEME OF CLASSIFICATION

CEPHALOCHORDA—*Amphioxus*.

CYCLOSTOMATA—Lampreys (*Petromyzon*) ; Hagfish (*Myxine*) and Borers (*Bdellostoma*).

ELASMOBRANCHII—Sharks and Dogfish ; Rays and Skates.

TELEOSTOMI—

I. Crossopterygii—*Polypterus*, *Calamichthys*.

II. Actinopterygii—

A. Ganoidei—Sturgeons (*Acipenser*), Garpike (*Lepidosteus*), Bowfin (*Amia*).

B. Teleostei—Herring, Salmon, Carp, Catfish, Eel, Pike, Cod, Perch, Flounder, Sole, and the great majority of ordinary fishes.

DIPNOI—Lungfish (*Lepidosiren*, *Protopterus*, *Ceratodus*).

AMPHIBIA—Urodela (Newts, Salamanders), Anura (Frogs, Toads), Apoda or Gymnophiona.

REPTILIA—Rhynchocephalia (*Sphenodon*), Lizards (Lacertilia), Snakes (Ophidia), Tortoises and Turtles (Chelonia), Alligators (Crocodylia), and many interesting extinct groups known from the fossil remains of their skeletons.

AVES—Birds.

MAMMALIA—Mammals, including all Vertebrates with hair and milk-glands—from the Duckbill and Opossums and their allies up to and including Man.

A GLANCE through the list given above will show that the phylum Vertebrata includes a large proportion of the most familiar and best-known

members of the animal kingdom. The phylum is of particular human interest and of special importance to the student of medicine, for it includes Man, and the study of its more archaic members affords many clues to the evolutionary history of the organs met with in the human being.

The Vertebrata are on the whole of relatively great size as compared with the invertebrates, and as they are of active habits this largeness of size involves comparatively great complexity of structure. Amongst this complexity certain features stand out as specially characteristic of the typical vertebrate.

The central nervous system is, as in the annelid or arthropod, concentrated into a longitudinal nerve-cord but this is characteristically tubular, being perforated longitudinally by a **central canal**. A striking physiological difference between the vertebrate and the annelid or arthropod, and one which has had a profound influence on the evolution of the phylum, is that the side of the body along which the nerve-cord runs—the **neural** side—is uppermost in the normal position of the body instead of being underneath, next the ground, as it is in a typical annelid or arthropod. Consequently all these features of structure—and they are very many—which are adaptations to the ordinary position of the body, are in a sense reversed as compared with the condition in annelids or arthropods. When the terms dorsal and ventral are used in regard to a vertebrate they refer simply to the position of the body normal to this phylum. The neural surface of a vertebrate is dorsal, that of an annelid is ventral.

The large size of the vertebrate and its activity of movement involve as in the arthropod the presence of a well-developed skeleton and the division of this into movable pieces, but whereas in the arthropod the skeleton is an exoskeleton, developed completely external to the living substance, in the vertebrate on the other hand it is an **internal skeleton**. This is built up of three elements (1) the **notochord**—a longitudinal elastic rod of cells split off from the neural (dorsal) surface of the alimentary canal; (2) blocks of the modified connective tissue known as gristle or **cartilage**—in which the rounded cells are embedded in a stiff translucent matrix possessing the chemical peculiarity that it gives rise to gelatine when acted on by boiling water under pressure; and (3) **bone**—also a modified connective tissue in which the cells are branched and the matrix heavily infiltrated with salts of calcium.

The muscular system of the vertebrate consists for the most part—in at least early stages of development—of longitudinal fibres arranged on each side of the body in segmental blocks or **myotomes**.

A well-developed body-cavity—coelomic in its nature—is present but it has lost the segmentation which is so pronounced a feature in the annelids.

The renal organs are nephridial tubes which, however, open not directly to the exterior but into a longitudinal duct on each side which in turn opens at its hinder end into the terminal part of the alimentary canal.

The wall of the pharyngeal region of the alimentary canal is perforated on each side—during at least the young state if not throughout life—by a series of **gill-clefts**, the lining of which forms in the lower aquatic vertebrates the main organ for respiratory exchange with the surrounding medium.

The fundamental plan of the blood-system of vertebrates is similar to that of annelid worms—a dorsal and a ventral longitudinal vessel

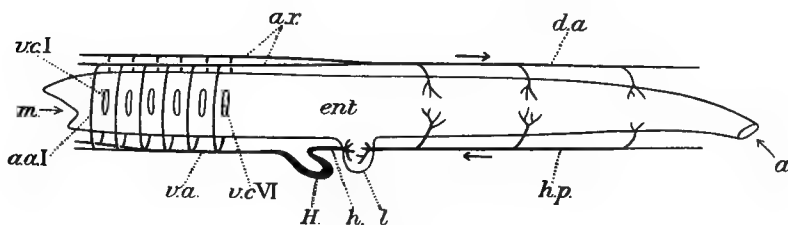

FIG. 120.

Diagram illustrating the arrangement of the main blood-vessels in the vertebrata. *a*, Anus; *a.a.I*, first aortic arch; *a.r.*, aortic roots; *d.a.*, dorsal aorta; *H*, heart; *ent*, enteron; *h*, hepatic vein; *h.p.*, subintestinal vein; *l*, liver; *m*, mouth; *v.a.*, ventral aorta; *v.c.I* and *VI*, visceral clefts.

being connected by hoop-like vessels round the sides of the alimentary canal. The main longitudinal vessel on the neural side (i.e. in this case the dorsal side) is the **dorsal aorta** (Fig. 120, *d.a.*); the ventral vessel is known as the **subintestinal vein** in its hinder portion (*h.p.*), while its front part lying beneath the pharynx is the **ventral aorta** (*v.a.*). The portion of ventral vessel immediately behind this is enlarged and forms the **heart** (*H*). The hoop-like vessels are distinct only anteriorly where they form the **aortic arches** (*a.a.*) passing from ventral aorta to dorsal aorta between consecutive gill-clefts.

STRUCTURE OF THE VERTEBRATA AS ILLUSTRATED BY THAT OF AN ELASMOBRANCH FISH

A general idea of the organization of a vertebrate is best got by the study of one of the comparatively archaic shark-like fishes such as the

Spotted Dogfish (*Scyllium*—Fig. 121, A) or the Spiny Dogfish (*Acanthias*—Fig. 121, B).

The form of the body is that of an elongated spindle, gradually tapering off towards the posterior end. The crescentic mouth is situated on the ventral side of the head: the anus or cloacal opening is situated ventrally, in *Scyllium* about the middle of the length of the body, the tail region behind it being about as long as the head and trunk regions lying in front of it. The body is prolonged outwards in the form of flattened projections—the **fins**—and these are distinguished as unpaired fins lying in the median plane of the body, and paired fins which project laterally.

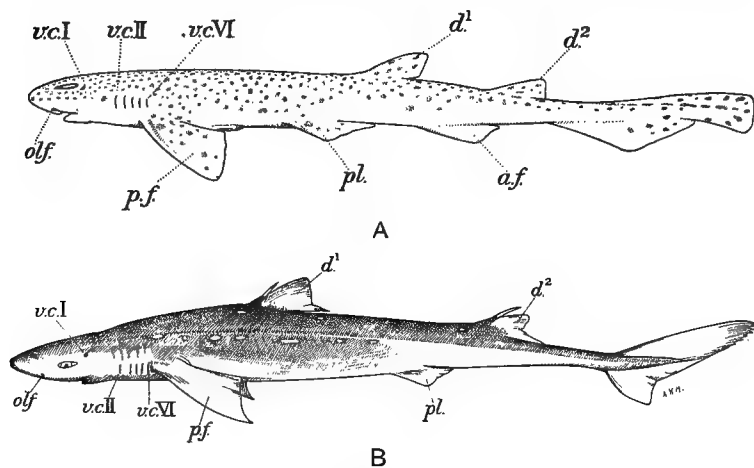

FIG. 121.

A, *Scyllium*; B, *Acanthias*. *a.f.* Anal fin; *d¹* and *d²*, dorsal fins; *olf*, olfactory organ; *p.f.* pectoral fin; *pl.*, pelvic fin; *vc.I*, spiracle; *vc.II* and *vc.VI*, second and sixth visceral clefts.

Of the latter there are two pairs, an anterior—the **pectoral** fins (*p.f.*)—and a posterior pair, situated at the sides of the cloacal opening—the **pelvic** fins (*pl.*). The median fins are in the young embryo in the form of a continuous fin-fold extending along a great part of the dorsal edge of the body, round the tip of the tail, and then along the ventral edge nearly to the anal opening. With further development large stretches of this fin-fold disappear while the intervening portions, increasing greatly in size, persist as the unpaired fins of the adult. Of these we distinguish two **dorsal** fins (*d*), an **anal** fin (*a.f.*—absent in *Acanthias*), and a **caudal** or tail fin. The last mentioned, which is better developed in *Acanthias* than in *Scyllium*, is unsymmetrical or **heterocercal**, this asymmetry affording a conspicuous difference in appearance between these shark-like fishes

and the ordinary fishes in which the caudal fin is symmetrical—its upper and lower halves being alike so far as external appearance is concerned.

The surface of the body of the Dogfish, as of any other typical vertebrate, is covered by a protective **skin** consisting of the persistent ectoderm or epidermis resting upon the **dermis**, a layer of connective tissue toughened by strong fibres running through it in all directions. It is this latter layer which gives to the skin of many vertebrates, especially when tanned and converted into leather, its remarkable toughness. The epidermis consists of several layers of cells. The cells of the innermost layer are in a state of active growth and multiplication while those of the outer layers are more or less degenerate, flattened in form and

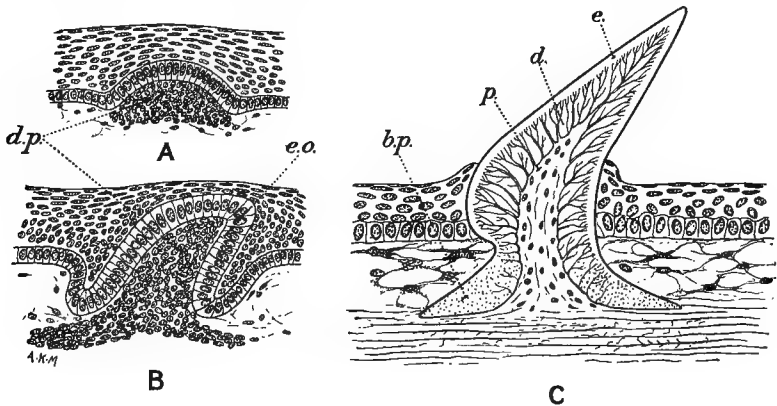

FIG. 122.

Placoid scale, as seen in longitudinal section. A and B, Early stages; C, fully-developed scale. *b.p.*, Basal plate; *d.*, dentine; *d.p.*, dermal papilla; *e.*, enamel; *e.o.*, enamel-organ; *p.*, pulp.

having their cytoplasm and nucleus stiffened and horny, so that they form a protective layer covering in the soft active cells of the deeper layers.

The skin possesses a highly characteristic skeleton in the form of **placoid scales**, of the greatest possible interest for in them we see, making its appearance for the first time in the series of existing vertebrates, the **bony tissue** which is destined to play such an important part in the skeleton of the higher vertebrates.

The placoid scale (Fig. 122, C) consists primarily of a hollow backwardly projecting spine composed of a special variety of bony tissue named **dentine** (*d.*). This is distinguished by the following characteristics: (1) that its cells (**odontoblasts**) are arranged side by side in a single layer lining the inner surface of the spine, (2) that calcification of the matrix

takes place only on the outer side of this layer of cells, and (3) that the branching processes of the cells radiate outwards through the calcified matrix as long, extremely slender threads of protoplasm. In sections through a dry scale the position of these protoplasmic threads is indicated by empty spaces commonly known as the dentinal tubules.

The outer surface of the spine is covered by a layer of especially hard calcified material (*e*) in which the terminal portions of the odontoblast processes are more or less obliterated. This probably corresponds to the substance known in the higher vertebrates as **enamel**.

The cavity of the spine is occupied by the **pulp** (*p*)—a prolongation of the ordinary connective tissue of the dermis, with its irregular cells, its uncalcified matrix, and its blood-vessels and nerves.

The basal edge of the cone of dentine is prolonged as a rule into a **basal plate** (*b.p*) lying in the dermis, by which it is fixed firmly in position. In this the regularity of arrangement seen both in the cells and in the calcified matrix of the true dentine tends to disappear, and the condition approximates more to that of ordinary bone such as occurs in the higher groups.

When the development of the placoid scale is traced out in the embryo it is found to make its first appearance as a concentration of the cells of the dermis close under the cuticle-like **basement-membrane** upon which the epidermis rests. This is succeeded by the formation of a dome-shaped and, later, oblique and pointed dermal papilla projecting outwards into the thickness of the epidermis (Figs. 122, A and B, *d.p*). The superficial cells of this papilla take on a regular arrangement along the inner surface of the basement-membrane and become the odontoblasts, while the layer of epidermal cells immediately contiguous with them assume an elongated columnar shape and are known collectively as the **enamel-organ** (Fig. 122, B, *e.o*). The portion of basement-membrane intervening between odontoblasts and enamel-organ becomes replaced by a cone of gradually increasing thickness—the dentine, over the surface of which the enamel makes its appearance. As regards the precise origin of dentine and enamel there is much divergence of opinion. The dentine is undoubtedly formed by the odontoblasts, i.e. it is of dermal origin: the main point of doubt regarding it is whether the calcified substance is to be interpreted as composed of secreted material passed out of the odontoblast into the intercellular spaces or on the other hand as being formed by the bodily conversion of the protoplasm of the odontoblast. While the former view is more generally accepted the present writer rather favours the latter.

Regarding the enamel the question is whether it is to be looked

upon—as it usually is in the higher animals—as being produced by the ectoderm cells of the enamel-organ or on the other hand as being simply the outer layer of dentine specialized and modified, possibly under the influence of the enamel-organ. The present writer considers the latter view to be on the whole the more probable.

Placoid scales of the type just described are scattered over the whole surface of the body, the spines projecting backwards. Shark's skin specially prepared (shagreen) is used for rasping, and the corresponding adjective "chagrined" is used in a figurative sense!

In the case of *Acanthias* there exists in front of each dorsal fin a powerful defensive spine which is capable of inflicting severe wounds: this is simply a placoid scale with its spine much enlarged.

The alimentary canal is a longitudinal tube leading from the mouth to the anal or cloacal opening. Apart from greater complexity in detail the wall of the alimentary canal is constructed on the same fundamental plan as that of the earthworm. Its inner surface is lined by a layer of endodermal epithelium: its outer surface is covered by the coelomic or peritoneal epithelium: while interposed between these layers is a muscular coat by which the peristaltic movements are brought about. Immediately external to the endoderm is a rich network of blood-vessels concerned with the absorption of the food.

The crescentic mouth leads into the buccal cavity which is in great part stomodaeal in its nature, representing a space on the ventral side of the head which has been floored in by a forward growth of the lower jaw. The cavity is consequently in part lined by enclosed portions of the outer skin. The roof of the buccal cavity for the most part is simply the skin of the ventral surface of the head: while on the floor of the cavity the outer skin extends inwards all round over the lower jaw. These enclosed portions of outer skin carry the usual armature of placoid scales. Over the greater part they are small or absent (*Scyllium*) but along a line just within the margin of the mouth opening there is a band of enlarged scales with prominent recurved spines. These are the **teeth** and here we come into touch with a fascinating conclusion of vertebrate morphology—that the teeth are simply specialized placoid scales. In the teeth of one of the higher vertebrates, e.g. a Man, we see the last persisting traces of the coating of placoid scales which covered the surface of the body in a far back ancestral stage.

That the teeth are in truth placoid scales can be demonstrated readily enough in *Scyllium* by making sections through the lower jaw when the typical tooth and the typical placoid scale outside are seen to be members

of a continuous series (Fig. 123): the fact receives further demonstration from the study of development which shows that early stages of the two organs are identical in appearance.

A remarkable arrangement is present whereby the teeth as they become worn down or broken off are replaced by new teeth. The tooth-bearing strip of skin covering the jaw is bounded all along its outer edge by a line along which gradual absorption of the skin is taking place.

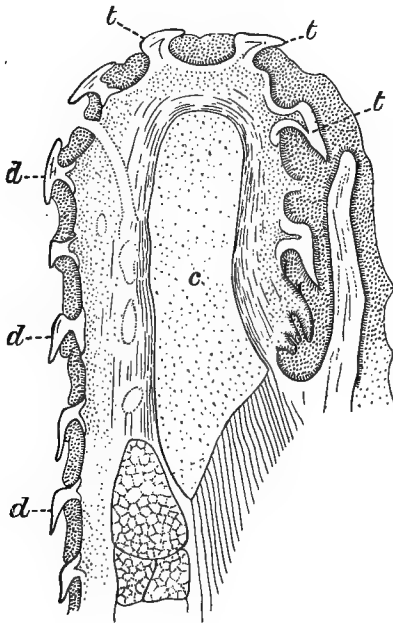

FIG. 123.

Transverse section through lower jaw of an embryo Dogfish (*Scyllium*) showing the gradual transition between placoid scales and teeth. (*The Cambridge Natural History*, vol. vii.; from Gegenbaur.) *c*, Cartilage of lower jaw; *d*, placoid scales; *t*, teeth.

It is bounded similarly along its inner margin by a formative zone, dipping deep down into the lining of the mouth, along which active growth of the skin is taking place. The result of this arrangement is that the tooth-bearing strip of skin is throughout the life of the creature undergoing a gradual outward movement, sliding as it were with extreme slowness over the jaw surface. The rate of this movement is nicely adapted to the normal rate of wear and tear of the teeth. A new tooth arising in the formative zone travels slowly outwards and after about the average period of usefulness it reaches the absorptive zone and is shed.

The thin marginal portions of the fins, both median and paired, are supported by numerous tough rays or filaments of horny appearance. These originate in the embryo in close relation with the basement membrane underlying the ectoderm and are therefore to a certain extent cognate with the placoid scales.

The pharynx, into which the buccal cavity is continued, is characterized in the Dogfish, as in all other Vertebrates during at least a portion of their developmental history, by the presence of the **gill-clefts** or branchial clefts. Of ordinary branchial clefts there are five pairs, each cleft being vertical in position and passing outwards through the entire

thickness of pharyngeal and body wall, there being no intervening coelomic space in the adult in this region. The external openings, which become somewhat restricted in dorsiventral extent as development proceeds, are seen arranged one behind the other along the side of the body just in front of and slightly dorsal to the pectoral fin (Fig. 121, *v.c.*). The five clefts are separated from one another by four **gill-septa**.

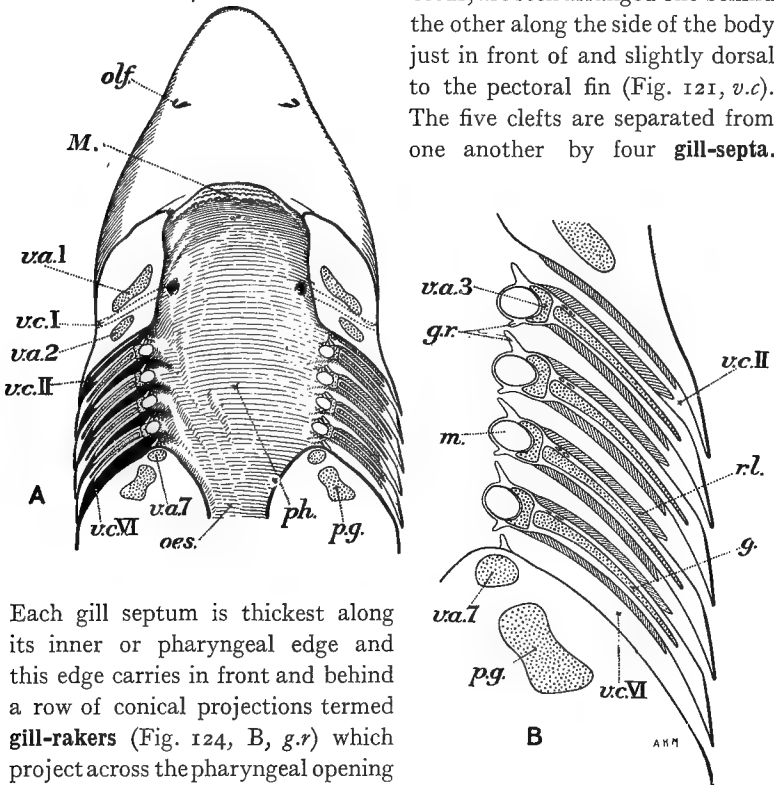

FIG. 124.

Each gill septum is thickest along its inner or pharyngeal edge and this edge carries in front and behind a row of conical projections termed **gill-rakers** (Fig. 124, B, *g.r.*) which project across the pharyngeal opening of the cleft and serve to prevent blocks of food material from passing outwards into the cavity of the cleft. In *Acanthias* both the anterior and the posterior row of gill-rakers are well developed: in *Scyllium* those of the posterior row are inconspicuous.

A, Horizontal section through gill-clefts of *Acanthias*. B, portion of similar section showing gill-clefts of left side on a larger scale. *g*, Gill ray supporting the septum; *g.r.*, gill-rakers; *M*, mouth; *m*, muscles of branchial arch; *oes*, oesophagus; *olf*, olfactory organ; *p.g.*, pectoral girdle; *ph*, pharynx; *r.l.*, respiratory lamella; *v.a.*, cartilage of visceral arch; *v.c.*, visceral cleft.

The actual respiratory surface through which gaseous interchange takes place between the blood and the water is afforded by the flat face of the septum on each side. In accordance with this the specially respiratory portions of this surface are provided with a rich network of

capillary blood-vessels (hence the bright red colour of the gills of a fish). Further the surface has its area increased by its growing out into flattened strap-like projections continuous with the septum along one edge and having the other edge free. These are the **respiratory lamellae** (Fig. 124, B, *r.l.*).

There are numerous lamellae radiating outwards upon each face of each gill-septum. Lamellae are also present upon the anterior wall of the first branchial cleft but there are none upon the posterior wall of the last cleft.

The septum is continued outwards past the outer ends of the lamellae and is eventually bent in a tailward direction, forming a valvular flap over the external opening of the gill-cleft immediately behind the septum. The effect of the presence of these valvular flaps is, while permitting the exit of water through the external opening of the cleft, to prevent its entrance.

In front of the series of ordinary gill-clefts is a modified cleft known as the **spiracle** (Figs. 121 and 124, *v.c.I.*), a short wide tube opening externally just behind the eye. The study of development shows this to be homologous with the other clefts : it is simply number I of the series : and a few vascular ridges (**pseudobranch**) upon its anterior wall indicate the persistent remains of the lamellae which were once present. The fact that spiracle and branchial clefts form a continuous series of homologous openings is expressed in the common name **visceral clefts**. The individual visceral clefts are designated by numbers, commencing from the anterior end of the series.

The live Dogfish keeps pumping sea-water over the respiratory lamellae by rhythmic breathing movements. The pharyngeal region is dilated by the action of appropriate muscles upon the skeleton of that region of the body. During this process water is drawn into the pharyngeal cavity through the slightly opened mouth and the spiracle, the external openings of the clefts being closed by the pressure of the water against the valvular flaps already mentioned. The pharyngeal region is now rapidly contracted, the mouth being closed and a valve being drawn across the opening of the spiracle, and the water rushes out through the gill-clefts, raising up the valvular flaps as it does so.

The pharynx is continued by a wide and short oesophagus (Fig. 125, *oes*) into the J-shaped stomach (*st*) the distal¹ limb of which is shorter and narrower than the proximal. At the **pylorus**, where the stomach passes into the intestine (*int*) the muscular wall of the alimentary

¹ In anatomical description the adjectives proximal and distal are used in the sense of "nearer" and "further."

canal is thickened to form a ring-shaped or **sphincter** muscle, known as

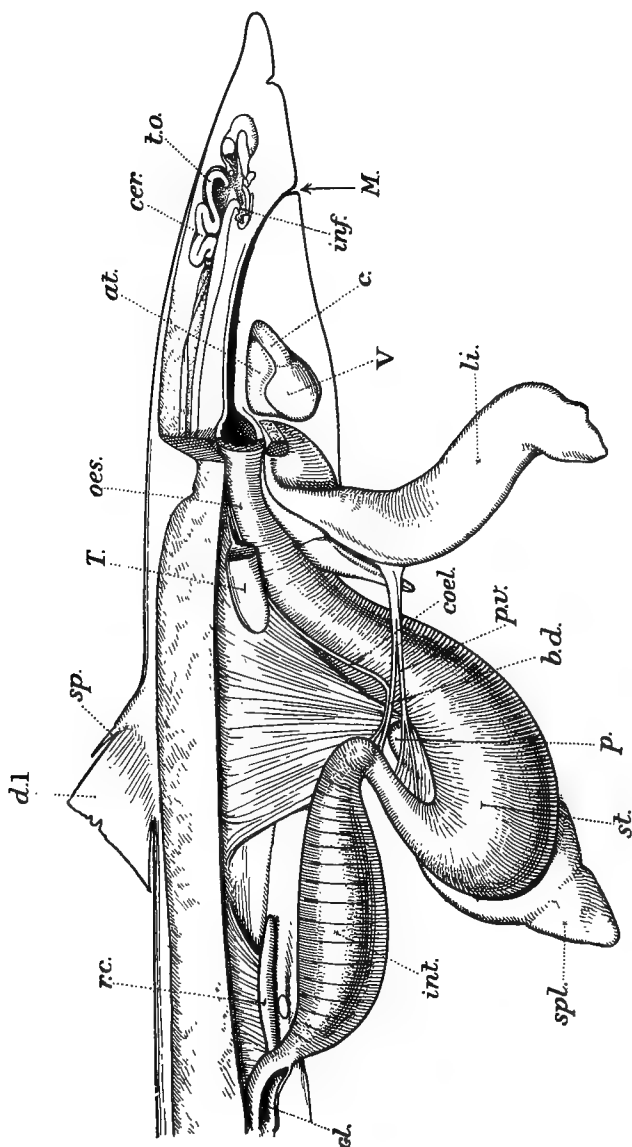

FIG. 125.

Acanthias, view of dissection from the right side. *at*, Atrium; *b.d.*, bile-duct; *c*, conus; *cer.*, cerebellum; *cl*, cloaca; *coel.*, coeliac artery; *d1*, first dorsal fin; *inf.*, infundibulum; *int.*, intestine; *li.*, liver; *M.*, muscle; *oes.*, oesophagus; *p.*, pancreas; *p.v.*, pyloric valve; *r.c.*, rectal caecum; *sp.*, spine; *spl.*, spleen; *st.*, stomach; *t.*, testis; *l.o.*, optic lobe; *V.*, ventricle.

the **pyloric valve**, by the contraction of which the passage of food can be prevented. The intestine, which is the main seat of the digestive

process, is short and wide and is provided with a remarkable **spiral valve**, the lining of the canal projecting inwards right to the centre as a broad spiral shelf round which the food is forced to travel as it passes onwards through the intestine. The physiological significance of this organ is obviously to increase the digestive area of intestinal lining with which the food is brought in contact. On the other hand it is also of morphological interest as it appears to be a reminiscence of a time when the primitive vertebrates possessed a long intestine coiled into a spiral. The wide part of the intestine containing the spiral valve is succeeded by a short narrow portion—the **rectum**—and this in turn by the terminal portion or **cloaca** (*cl*).

The primary function of the alimentary canal—the digestion and assimilation of the food—necessitates its being provided with glands for the secretion of digestive ferments and other substances concerned in these processes. As in the case of the Earthworm numerous gland-cells are scattered throughout the endodermal lining. Other gland-cells are congregated together in localized outgrowths of the enteric wall, forming bulky glands. Of these the most conspicuous is the **liver** (Fig. 125, *li*) which is indeed the most bulky organ in the coelomic cavity. The liver is a compact organ possessing two main lobes, a right and a left, and in the case of *Acanthias* a small intermediate lobe in addition. It consists of a mass of fine anastomosing tubules and its secretion drains by a duct—the **bile-duct**—into the intestine close to its front end. Connected with the bile-duct is a reservoir—the **gall-bladder**—which in *Scyllium* is embedded in the left lobe of the liver and almost completely hidden from view, and in *Acanthias* is partially ensheathed in the small intermediate lobe.

From its relation to the alimentary canal there can be little doubt that the vertebrate liver was originally a digestive gland, but although its secretion—the **bile**—still plays a certain part in digestion, particularly in breaking up fat into finely divided particles, the digestive function has in the modern vertebrate become less conspicuous owing to the rise in importance of other functions. One of these is the excretory function. Various waste materials are extracted from the blood and got rid of in the bile, some of them deeply coloured pigments which give the bile a characteristic yellow or green colour. Again the liver is the chief seat of formation of the important nitrogenous waste substance **urea**. This is formed in the metabolism of the nitrogenous products of protein digestion brought from the intestine by the blood of the portal vein: it is then passed back into the blood-stream to be carried to the kidneys and there got rid of. Another important function is that of acting as

a temporary store-house for carbohydrate or starchy material. After a meal the carbohydrate absorbed from the food is transported to the liver in the blood-stream, in the form of dextrose or grape-sugar. As the blood passes through the capillary network of the liver the carbohydrate is extracted from it by the activity of the liver-cells and stored up in their cytoplasm in the form of **glycogen**—a substance of the same chemical composition as starch but apparently possessing some slight difference in physical constitution. The carbohydrate, which reaches the liver in a large instalment after each meal, is doled out again to the circulating blood as it is required for the metabolism of the tissues.

The other bulky gland associated with the alimentary canal is the **pancreas** (Fig. 125, *p*), an elongated organ of a characteristic whitish colour¹ lying in the bend between stomach and intestine and opening into the latter near its front end by the **pancreatic duct**. In *Acanthias* the pancreas is remarkably variable, being in some cases large and well developed, while in others it is so slightly developed as to be hidden from view in the thickness of the intestinal wall.

The pancreas is the most important of the digestive glands in existing vertebrates. Its secretion is strongly alkaline and contains a number of powerful digestive ferments, each with its specific rôle in the digestion of some particular type of food material. Thus one type of ferment (tryptic) is concerned with the digestion of protein, another with that of fat, another with that of starch, and so on. By the action of these ferments the various food substances in the cavity of the intestine are reduced to soluble form and made ready for absorption by the intestinal lining.

A glandular thick-walled caecum—the **rectal gland** (Fig. 125, *r.c*)—opens into the rectum on its dorsal side.

Along with the glandular appendages of the alimentary canal already mentioned there must be grouped the remarkable organ known as the **thyroid gland**, although in the adult vertebrate it has no longer any obvious connexion with the alimentary canal. This makes its appearance in the embryo as a median pocket-like downgrowth of the floor of the pharynx, between the level of the first and second gill-clefts. The connexion with the pharynx becomes narrowed and finally obliterated, and the closed sac so formed becomes divided up into a large number of small spherical vesicles, embedded in a framework of connective tissue. The lining of these vesicles produces a clear colloid secretion which accumulates in the cavity of the vesicles, the original outlet to the

¹ As seen in the "sweetbread" of the kitchen.

pharynx having been lost: the thyroid in its completed form is an excellent example of what is known as a **ductless gland**.

As already indicated the cells of the body are adapted to what may be called an aquatic existence, to life in an internal watery medium—very complex in composition owing to its containing in solution many and varied products of the metabolism of the various tissues. It is essential to the health of the body that this complexity should be approximately normal, the various components being present in definite proportions, although slight divergences from the normal may be harmless and indeed may be of definite use in stimulating particular organs or tissues to special activity. Thus an exceedingly slight increase in the amount of carbon dioxide in the internal medium is at once followed by increased activity in the respiratory movements so as to facilitate respiratory exchange. Again there is produced in the metabolism of the lining cells of the anterior portion of the intestine an obscure substance to which the name secretin has been given: the presence of food in the alimentary canal causes this to be produced in increased quantity: and its presence in increased quantity in the internal medium, especially in the circulating blood, at once brings on increased secretory activity on the part of the pancreas—so that pancreatic juice is provided for the digestion of the food.¹

The primary function of a gland is the extraction of some specific substance or substances from the circulating blood—i.e. from the internal medium, and the passing it on, by way of the duct, to the exterior or to some cavity in the body. It is, however, characteristic of the living body that such action is always to a certain extent reciprocal, never absolutely one-sided. In some cases the reciprocal action is very obvious, as for example in the case of the respiratory exchange between a tissue-cell and the blood. Oxygen passes from the blood to the tissue-cell and conversely carbon dioxide passes away from the tissue-cell into the blood. In other cases the exchange between blood and cell is markedly unequal, the process being very active in the one direction and comparatively sluggish in the other. Such is the case in an ordinary gland where the exchange from blood to gland-cell is conspicuous, giving rise to the ordinary secretion, while the exchange from gland-cell to blood is comparatively inconspicuous and obscure, giving rise to what is called an **internal secretion**.

Although small in amount and obscure in nature these internal secretions may be of high physiological importance: they frequently

¹ Such substances in the internal medium which bring about a specific reaction are commonly given the special name of **hormones**.

constitute contributions to the internal medium of the body which are of the greatest moment to its healthy metabolism. Thus in the case of the pancreas, in addition to the obvious secretion already alluded to, there is believed to be produced some obscure contribution to the internal medium the presence of which in normal proportion is essential to healthy carbohydrate metabolism, its absence causing carbohydrate to accumulate in the blood in the form of sugar. Now in the ductless glands it is the production of these internal secretions which has become the predominant function of the organ. In the case of the thyroid the ordinary secretion is still produced but it no longer finds an exit into the alimentary canal: the really important product is an obscure internal secretion which passes from the gland into the internal medium by way of the blood circulating through its capillaries. Abnormal proportion of this internal secretion is known from investigations on the higher vertebrates to cause serious disturbance of healthy metabolism, interfering with mental and sexual development and with the growth of tissues, particularly skeletal tissues. The disease known as "goitre" in human beings is caused in this way: enlargement of the thyroid and interference with its function being apparently brought on by infection by some unknown microbe inhabiting drinking water in certain regions. And the children born of a mother with goitre are apt to show the condition of mental and physical deficiency known as "cretinism."

Another ductless gland associated with the alimentary canal is the **thymus**. This arises in the form of a series of outgrowths from the epithelium lining the visceral clefts, close to their dorsal ends. The several outgrowths fuse together, lose their connexion with the pharynx and form an inconspicuous organ lying along the jugular vein. The internal secretion produced by the thymus, whatever its nature may be, would appear to be of special importance during the period of growth as it commonly shrinks as a vertebrate approaches its adult size.

There is evidence, as will appear later, that the vertebrates are descended from ancestors which possessed a coelomic body-cavity divided up into segmentally arranged compartments like those of an annelid worm, each compartment formed by the fusion of an originally separate right and left half. In the modern vertebrate, however, this segmentation disappears except as regards the dorsal portion of each compartment. In this the cavity becomes obliterated, while the epithelial lining undergoes an immense thickening and becomes converted into longitudinal muscle-fibres—each fibre running only the length of a single segment. These segmentally arranged blocks of muscle-fibres—known as **myotomes**

—originally dorsal in position, spread downwards in a ventral direction, interposing themselves between the more ventral part of the coelome and the surface of the body, so that the whole of the side of the body becomes muscularized down to the mid-ventral line. In a fish the somewhat Σ -shaped myotomes are easily seen if the skin is stripped off a portion of the body: they form the flakes into which a cooked piece of fish readily divides.

In this arrangement of the main muscles in the form of segmental blocks of longitudinal fibres we have one of the most fundamental characteristics of the phylum Vertebrata. In the fishes throughout life the main part of the muscular system remains in the form of typical myotomes. In other types of vertebrate—e.g. in a man or a bird, where the myotomes become during development broken up into pieces, displaced in position and obscured in various ways—they are still apparent in perfectly typical condition during early stages of development.

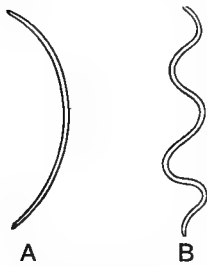

FIG. 126.

Lateral curvature of the body: (A) as it would take place if the muscle fibres extended from end to end of the body; (B) as it takes place with the longitudinal muscles subdivided into successive segments.

This fundamental arrangement of the vertebrate muscular system is also of great physiological interest, for such an arrangement is clearly intended for the production of movement like that of an Eel when it swims: it indicates to us that the primitive vertebrate swam by waves of lateral flexure passing backwards along the body. It is obvious that if the individual fibres extended the whole length of the body, contraction of those on one side would simply bend the body in a single curve towards that side (Fig. 126, A). The division of the longitudinal muscles into short segments renders it possible on the other hand for restricted portions of the body to be bent to one side or the other irrespective of what may be happening in other portions. Further, by the muscle segments being caused to contract in order from the head-end backwards, a succession of waves of curvature (Fig. 126, B) may be passed back along the body, the mechanical effect of which will be to push the body forwards. This is what happens when an Eel swims and the universal presence of these segmental blocks of muscle in early stages in the development of all vertebrates affords strong evidence that the type of movement described was the primitive mode of movement in the common ancestors of existing vertebrates.

The fins, both paired and unpaired, are provided with special muscular

arrangements of their own; but these are originally simply prolongations from the ends of the myotomes which sprout out into the fin rudiments and become eventually separated off from their parent myotomes.

The more ventrally situated portion of the coelome or **splanchnocoel** has in the Dogfish, as in all typical vertebrates, completely lost all trace of segmentation. It forms even in young stages a continuous cavity from end to end. In the later stages of development, however, a secondary division of the **splanchnocoel** takes place into a small anterior chamber containing the heart—the **pericardiac** cavity—and a main portion containing the greater part of the alimentary canal—the **peritoneal** cavity. In the Dogfish and its allies, though not in the higher vertebrates, these cavities remain connected with one another by a slender **pericardio-peritoneal canal** which extends back from the pericardiac cavity, just dorsal to the heart, and opens into the **splanchnocoel** by an inconspicuous slit on each side on the ventral surface of the oesophagus (Fig. 134, *ppc*).

As already mentioned there is reason to believe that the coelomic cavities were originally paired, consisting of left and right halves. It is characteristic of the vertebrate that, while these two halves become completely continuous with one another across the mesial plane on the ventral side of the alimentary canal, they remain separated from one another on its dorsal side by a thin membranous partition. This is the mesentery, which serves to sling up the alimentary canal to the roof of the peritoneal cavity and incidentally constitutes a bridge by which blood-vessels and nerves pass to the enteric wall.

The Vertebrate, like the Annelid, possesses numerous pairs of nephridial tubes, but they show this distinctive peculiarity that, instead of opening independently on the surface (Fig. 127, A), the whole series of tubes on each side of the body opens into a longitudinal duct which in turn opens posteriorly into the cloaca or hinder portion of the alimentary canal (Fig. 127, B). The whole complex of tubes on each side of the body is termed the **archinephros** and the longitudinal duct is termed the **archinephric duct** (Fig. 127, B, *a.n.d.*). Comparing the available stages in the evolution of vertebrates, as disclosed to us by different stages of individual development and by the arrangements in adult members of the various subdivisions of the phylum, it is seen that the archinephros has in the course of evolutionary history undergone modifications of a characteristic kind. In its individual development the vertebrate develops from the head end backwards, segmentally arranged organs developing serially one after the other. Consequently we should expect the tubes of the archinephros to appear in regular sequence, one after the other from the

anterior end of the organ backwards. As a matter of fact this sequence does occur, but its regularity is interfered with by a tendency of the tubes to develop in batches. First a few tubules at the front end of the series develop one after the other—constituting what is termed the **pronephros** (Fig. 128, B, *pn*). In those vertebrates which have a larval stage the tubules of the pronephros become greatly enlarged, so that it is able to overtake the whole excretory needs of the individual during this stage. The tubules which would develop in the next succeeding segments do not make their appearance—being unnecessary owing to the great development of the tubules in front of them. It is only when it comes to be the turn of a segment further back in the series to develop a tubule

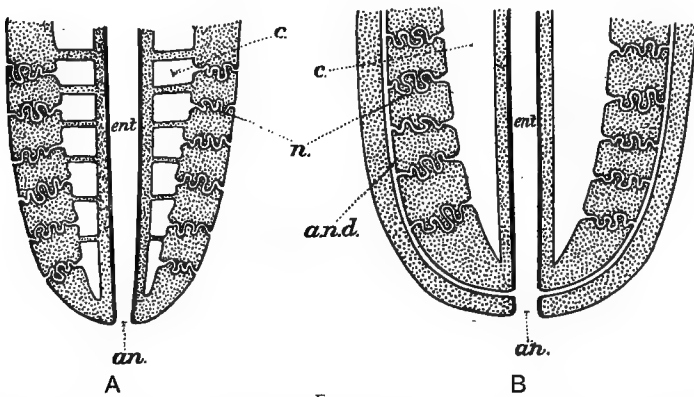

FIG. 127.

Diagram illustrating the arrangement of the nephridial tubes of Annelids (A) and Vertebrates (B). *an* Anal opening; *a.n.d.* archinephric duct; *c*, coelome; *ent*, enteron; *n*, nephridium.

that the tubule actually makes its appearance. Successive tubules now go on developing right back to the hinder end of the coelome, and the whole of these constitute the **opisthonephros** (Fig. 128, B, *op*). The opisthonephros takes on the excretory function hitherto performed by the pronephros, and the latter, no longer required, rapidly dwindles away. The opisthonephros forms the functional excretory organ or kidney of the fishes and other lower vertebrates.

In the higher vertebrates, from the Reptiles onwards, the opisthonephros becomes again differentiated into two portions—an anterior—the **mesonephros**—which loses its excretory function in the adult and becomes related to the reproductive process—and a hinder portion—the **metanephros** (Fig. 128, D, *mn*)—composed of the hinder tubule or tubules which become immensely enlarged and added to by the development of

new generations of tubules, associated with and opening into them, until they form the bulky kidney of the adult.

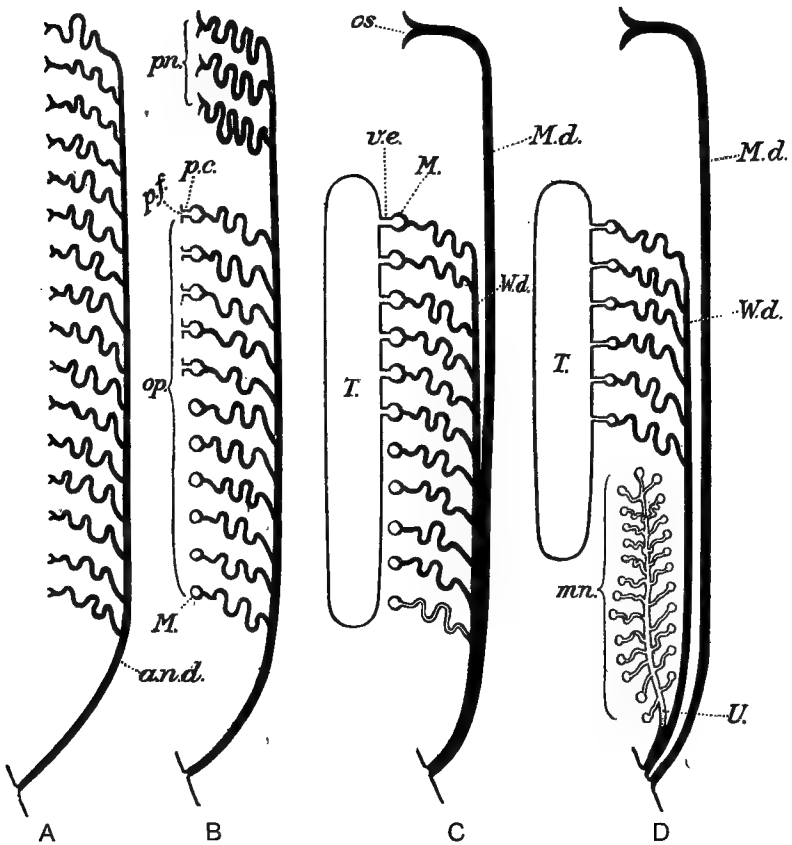

FIG. 128.

Diagram to illustrate the evolution of the nephridial organs of vertebrates. A, Supposed primitive condition. B, A group of tubules in front have become differentiated as the pronephros from the remainder which constitute the opisthonephros, while the portions of splanchnocoel immediately adjacent to the nephrostomes have become partially or completely separated off from the main splanchnocoel as the cavities of the Malpighian bodies. C, Certain of the Malpighian bodies are connected with the testis, their tubules serving to transmit the male gametes; the pronephros is reduced to a single greatly widened tubule which forms the internal funnel of the oviduct; the archinephric duct is splitting into the Wolffian duct continuous with the opisthonephric tubules and the Müllerian duct (oviduct) continuous with the persisting pronephric tubule. D, The hindmost tubule has sprouted to form a large tree-like mass of tubules—the metanephros, while its backward continuation is splitting off as the ureter from the Wolffian duct or vas deferens. The opisthonephric tubules connected with the testis form the epididymis. *a.n.d.*, Archinephric duct; *M.*, Malpighian body; *M.d.*, Müllerian duct; *mn.*, metanephros; *op.*, opisthonephros; *os.*, internal funnel of oviduct; *p.c.*, peritoneal canal; *p.f.*, peritoneal funnel; *pn.*, pronephros; *T.*, testis; *U.*, ureter; *v.e.*, vas efferens; *W.d.*, Wolffian duct.

Primitively the nephridial tube of the vertebrate opens at its inner end by a funnel-like nephrostome from the coelomic body-cavity or splanchnocoel. One of its primitive functions is to get rid of the fluid passed into that cavity by the coelomic lining. In correlation with this the portion of coelomic lining facing the nephrostome develops greatly increased powers of secreting coelomic fluid: it also becomes increased in area, bulging into the coelomic cavity as a rounded swelling—the **glomerulus**—and receives a special blood supply, a branch from the aorta breaking up into a network in the interior of the glomerulus, in close contact with the secretory epithelium.

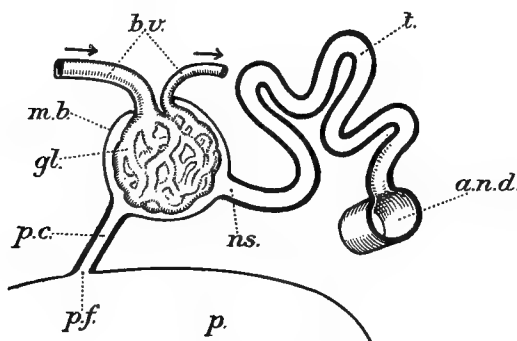

FIG. 129.

Diagram of renal tubule of vertebrate with its Malpighian body. *a.n.d.*, Archinephric duct; *b.v.*, blood-vessels—afferent and efferent; *gl.*, glomerulus, network of vessels closely ensheathed by epithelial covering; *m.b.*, Malpighian body; *ns.*, nephrostome; *p.*, peritoneal cavity; *p.c.*, peritoneal canal; *p.f.*, peritoneal funnel; *t.*, tubule.

In the case of the pronephros the glomeruli are very large and undergo fusion together, so that the group of pronephric tubules on each side has a large compound glomerulus projecting into the coelomic cavity towards them. In the opisthonephros on the other hand the small individual glomeruli remain separate and the portion of coelome immediately surrounding each one of them becomes more or less completely separated off from the main splanchnocoel. Consequently each glomerulus in the opisthonephros is surrounded by a narrow space enclosed by a membranous wall, the whole constituting what is known as a **Malpighian body**. Where a communication remains between the cavity of the Malpighian body and the main splanchnocoel this communicating channel is called the **peritoneal canal** (Figs. 128, B, and 129, *p.c.*) and its splanchnocoelic opening the **peritoneal funnel** (Figs. 128, B, and 129, *p.f.*).

Important changes also take place in connexion with the longitudinal

ducts, changes associated with the need of separating off the path by which the reproductive cells reach the exterior from that taken by the highly poisonous excretory products. These changes are seen with particular clearness during the individual development of the Dogfish and its allies. The archinephric duct undergoes a longitudinal splitting from before backwards into a **Wolffian duct** (Fig. 128, C and D, *W.d.*), into which open the tubules of the opisthonephros, and a **Müllerian duct** (*M.d.*), into which opens what remains of the pronephros—a single greatly dilated tubule. The Wolffian duct serves for the conveyance (1) of the urine or excretory fluid from the kidney and (2) also, owing to the presence of a connexion with the testis to be described presently, of the microgametes or spermatozoa. The Müllerian duct is functional only in the female: it functions as the oviduct, the greatly enlarged pronephric nephrostome at its anterior end allowing the eggs to pass into it from the splanchnocoel.

The gonads of the vertebrate are originally, like those of the Earthworm, simple thickenings of the coelomic (peritoneal) epithelium, although here in correlation with their great increase in size there necessarily comes about also a great increase in complexity of detail.

What has been said so far refers to the urino-genital organs of the Vertebrata in general, and it is now necessary to describe the arrangements as they occur in the Dogfish in particular.

Both ovaries and testes are originally two in number, but in the case of the former only one (the right) becomes functional, the other disappearing. The functional ovary (Fig. 130, B, *O*) is a large organ attached to the dorsal wall of the peritoneal cavity by a thin fold of peritoneal lining (**mesovarium**). Its appearance is very characteristic owing to the eggs, as they approach maturity, storing up in their cytoplasm enormous quantities of reserve food-material or yolk, so that each forms a large yellowish sphere bulging out from the surface of the ovary. The egg is eventually shed into the peritoneal cavity and is carried forwards, in a way not yet fully worked out, into the funnel-like opening of the Müllerian duct (Fig. 130, B, *M.d.*).

In the male the gametes, instead of being shed freely into the peritoneal cavity, pass into a cavity in the interior of the testis (Fig. 130, A, *T*)—a paired body slung up to the dorsal wall of the peritoneal cavity by the thin membranous **mesorchium**—and thence by a group of fine tubular **vasa efferentia** (*v.e.*), situated at the front end of the testis, into the front end of the opisthonephros.

The kidney (Fig. 130, *op*) is an opisthonephros—the pronephros

appearing only as a small rudiment in the embryo. The opisthonephros is much elongated in form, lying dorsally, immediately outside the peritoneal cavity along practically its whole length. The actual renal

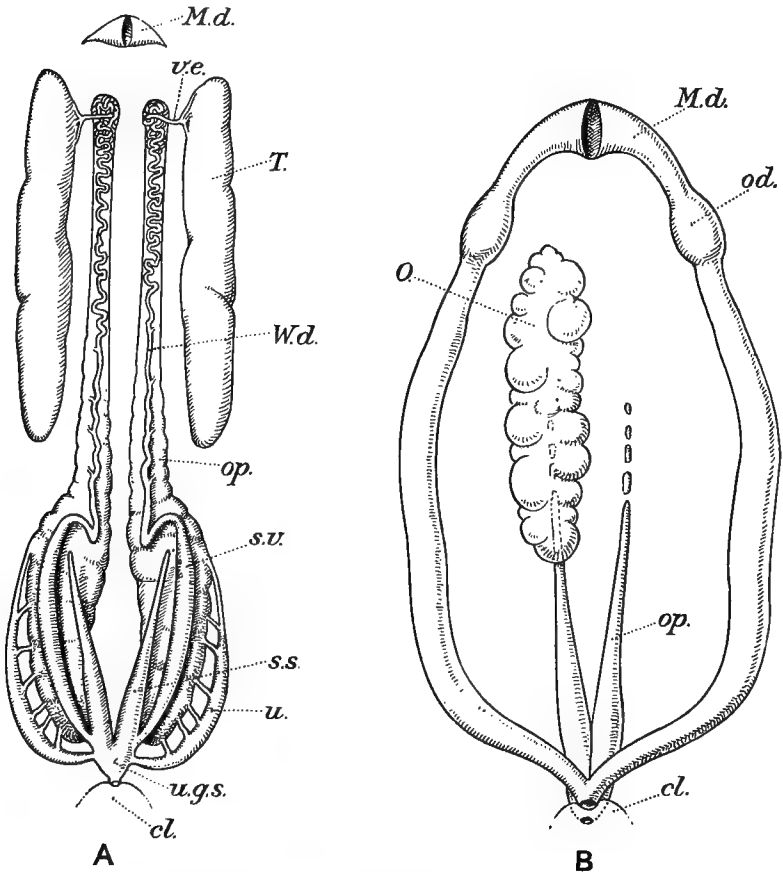

FIG. 130.

Diagram of urino-genital organs of the Dogfish (*Scyllium*), as seen from the ventral side. A, male; B, female. *cl.*, Cloaca; *M.d.*, Müllerian duct; *O.*, ovary; *od.*, oviducal gland; *op.*, opisthonephros; *s.s.*, sperm-sac; *s.v.*, seminal vesicle; *T.*, testis; *u.*, ureter; *u.g.s.*, urino-genital sinus; *v.e.*, vasa efferentia; *W.d.*, Wolffian duct.

function is carried out mainly if not entirely by the hinder half of the organ, the anterior half being in the female reduced to an inconspicuous and vestigial condition, while in the male, where this front portion of the opisthonephros is concerned in the reproductive function, the reduction in size is less marked.

The Müllerian duct or oviduct, a wide and conspicuous tube (Fig. 130, B, *M.d*) in correlation with the large size of the eggs, runs back along the roof of the peritoneal cavity from its funnel, situated on the edge of a suspensory membrane ("falciform ligament") lying in front of the liver, to the hind end of the cavity where it unites with its fellow of the opposite side before opening into the cloaca (Fig. 130, B, *cl*). A peculiarity of the Dogfish and some of its allies is that the funnels of the two oviducts are merged together into a single opening. A portion of the duct near its anterior end is swollen up to form a somewhat ellipsoidal body—the **oviducal gland** (Fig. 130, B, *od*). The secretion of this is deposited round the egg during its passage, so as to enclose it, together with a small quantity of albumen or white, in a shell of horny consistency and of a characteristic pillow-case shape, with the four corners drawn out into elastic tendrils which at the time the egg is laid are coiled round seaweeds so as to anchor it in position.

In the male Müllerian ducts make their appearance just as in the female, but in this case they gradually atrophy so that in the adult all that remains is the peritoneal opening, leading into a tapering pocket upon each side representing the anterior end of the duct (Fig. 130, A, *M.d*).

The Wolffian duct is in the female a simple straight tube which runs back along the ventral side of the opisthonephros, becoming considerably dilated posteriorly and uniting with its fellow before opening into the cloaca at the tip of a small papilla situated immediately behind the opening of the oviducts. In the male the arrangement becomes much more complicated. The fused posterior portion of the ducts—the **urino-genital sinus** (Fig. 130, A, *u.g.s*)—is much larger and it bulges forwards on each side as a pointed projection known as the **sperm-sac** (*s.s*). The main portion of the duct, lying in front of this, pursues an extremely sinuous course along the ventral face of the anterior half of the opisthonephros, receiving as it does so the collecting tubes or terminal portions of the tubules of this part of the kidney. Posteriorly it becomes straight and at the same time much dilated forming the **seminal vesicle** (*s.v*). The collecting tubes of the posterior, functionally renal, part of the opisthonephros no longer open directly into the Wolffian duct but lead into a separate urinary duct ("ureter"—Fig. 130, A, *u*) which opens independently into the posterior fused portion of the ducts (urino-genital sinus).

Finally it must be noticed that in the male a portion of the pelvic fin on its inner side is modified to form a **clasper** which functions in the conveyance of the microgametes into the cloaca and oviduct of the female. The microgametes make their way by active swimming

movements up the cavity of the oviducts, and the actual process of syngamy takes place towards the upper end of the tube before the egg has become enclosed in its shell.

The skeleton of the vertebrate is, as already indicated, an internal skeleton, and we can recognize within the phylum three distinct phases in its evolution which may be distinguished as (I) the notochordal, (II) the cartilaginous, and (III) the osseous or bony phase. Of these three phases the first is found in the Dogfish, as in the majority of vertebrates, only in the developing embryo. It is represented by a simple elastic rod—the notochord—lying along the dorsal side of the body immediately ventral to the central nervous system, and extending from just behind the tip of the infundibulum back practically to the tip of the tail. The notochord is of the greatest possible morphological importance, for the skeleton of every vertebrate, even the highest and most complicated, passes through a stage in which it consists of a simple notochord.

The notochord is endodermal in origin and is at first a simple rod of endodermal cells (Fig. 131, A) separated off from the dorsal wall of the embryonic alimentary canal. The superficial cells of this rod form on their surface a strong cuticular membrane—the **primary sheath** (s.I)—which invests the notochord from end to end. As the embryo develops the notochord increases actively in length and in thickness, and this growth is brought about mainly by the great increase in volume of its constituent cells, due to their developing large vacuoles in their interior. This does not apply, however, to all the cells, for those on the surface of the notochord remain unvacuolated, forming a layer of **notochordal epithelium** (Fig. 131, B, *n.e.*). These cells continue to form cuticular substance but now, instead of being thin and membranous, this is thick and jelly-like and is known as the **secondary sheath** (C, s.II).

There now makes its appearance a new type of skeletal tissue—cartilage (see p. 292)—which is destined to form the whole of the complicated fully developed skeleton with the exception of the placoid scales and the notochord.

The spinal cord, which as has already been indicated lies immediately dorsal to the notochord (Fig. 132), is covered over by a kind of tunnel of connective tissue (Fig. 131, C, *c.t.*): in the tail-region a similar tunnel, but in a reversed position with its apex downwards, shelters the great blood-vessels—the caudal artery and vein. It is in the walls of these tunnels that the cartilage first makes its appearance in the form of paired blocks in immediate proximity to the sheath of the notochord. These blocks form the rudiments of what are known as the **neural arches**

(dorsal—Fig. 131, C, *n.a.*) and the **haemal arches** (ventral—Fig. 131, C, *h.a.*) respectively. The appearance of these blocks of cartilage is followed by the occurrence of a remarkable process by which the whole secondary sheath of the notochord becomes converted into a cylinder of cartilage. Certain cells of the arch rudiments assume an amoeboid character, forsake their original position, creep towards the primary sheath, bore their way through it, apparently by the secretion of a digestive ferment, and, finding themselves in the secondary sheath (Fig. 131, C, *c.c.*), distribute

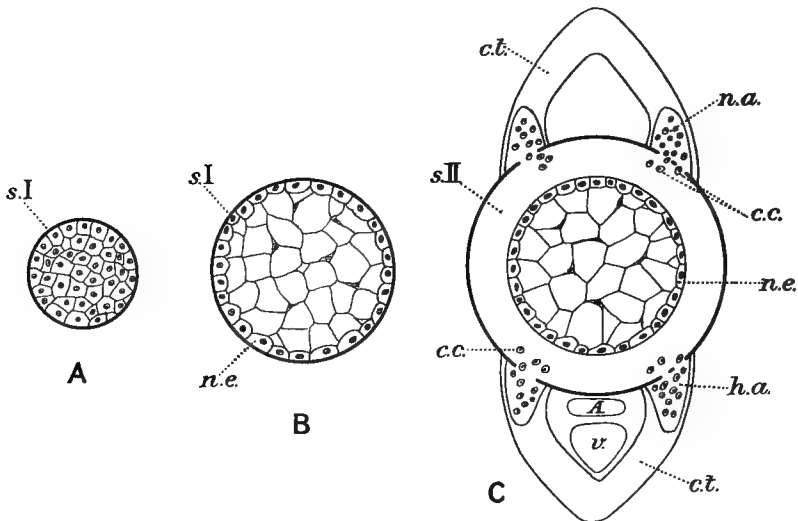

FIG. 131.

Diagrammatic transverse sections through the notochord of a Dogfish (post-anal region) at three different stages of development. A, Dorsal aorta (caudal artery); *c.c.*, cartilage cells; *c.t.*, connective tissue arches; *h.a.*, cartilaginous haemal arch rudiment; *n.a.*, cartilaginous neural arch rudiment; *n.e.*, notochordal epithelium; *s.I.*, primary sheath; *s.II.*, secondary sheath; *v.*, caudal vein.

themselves throughout its substance and there settle down—re-assuming the character of typical cartilage cells and in turn so influencing the substance of the sheath as to cause it to take on the typical characteristics of cartilage matrix. By this remarkable immigration of cartilage cells from the neural arches the whole substance of the secondary sheath becomes converted into cartilage.

The wall of this at first homogeneous cylinder of cartilage becomes thickened at regular intervals, the ring-shaped thickened portions growing inwards so as to constrict the notochord which fills the interior of the cylinder until in the centre of the thickening the notochord is reduced

to a comparatively thin thread. In the skate it becomes interrupted entirely. The thickening of the cartilaginous wall of the cylinder dies away anteriorly and posteriorly and is separated from the next thickened portion by a ring of unthickened cartilage which gradually loses its original character and becomes converted into tough fibrous tissue. In this way the originally continuous cylinder of cartilage becomes segmented up into a series of pieces known as vertebral **centra**, bound together by strong **intervertebral ligaments**. It will be understood that each centrum has externally the form of a short cylinder, and that it contains two deep

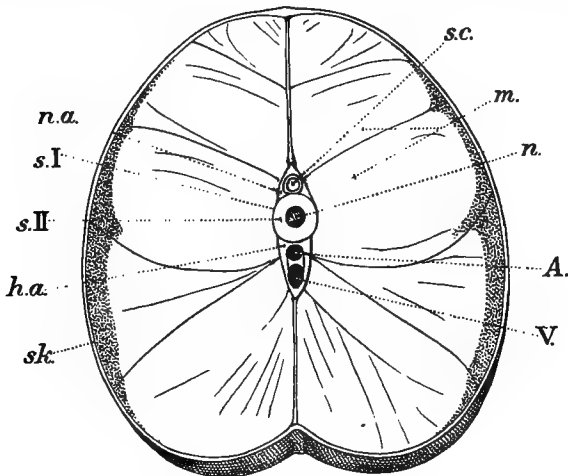

FIG. 132.

Transverse section through front portion of tail region of *Acanthias*. A, Dorsal aorta (caudal artery); h.a, haemal arch; m, myotomes separated by thin septa of connective tissue; n, notochord; n.a, neural arch; s.I, primary sheath; s.II, secondary sheath; s.c, spinal cord; sk, skin; V, caudal vein.

cavities—one anterior and one posterior—in the form of two cones arranged apex to apex and opening into one another at the point where the two apices meet. Such a vertebral centrum with a conical cavity at each end is termed **amphicoelous** and this form of centrum is characteristic of all ordinary fishes. In the fresh condition the conical cavities are not empty but are filled by the notochord which traverses them.

At their distal ends the neural arch rudiments gradually extend until they meet in the mesial plane over the spinal cord (Fig. 132) and the apical portion so formed continues its outward growth to form a **neural spine**.

An interesting point to be noticed in the Dogfish and in various other

lowly organized vertebrates is that throughout the greater part of the vertebral column there are two neural arches—an anterior and a posterior—corresponding to each centrum. In other words in a given length of vertebral column there are twice as many neural arches as there are centra. This appears to be the primitive condition but in the more highly evolved vertebrates the anterior arch has apparently disappeared leaving only a single neural arch corresponding to each centrum.

In the tail region the haemal arch rudiments behave very much as those of the neural arches, complete haemal arches being formed, prolonged into haemal spines. Further forward on the other hand, where the small space enclosing the caudal artery and vein is replaced by the large peritoneal cavity, the arch rudiments never meet ventrally but merely spread out some distance in the body wall. Their terminal portions become segmented off to form the **ribs** while their basal portions continuous with the centrum are termed **transverse processes**.

A necessary property of the vertebral column is its flexibility, so as not to interfere with the flexure of the body from side to side in swimming, and this flexibility is ensured by its being segmented up into the individual vertebrae. When traced forwards towards the head region, where the presence of the brain demands rigidity instead of flexibility, the segmentation of the vertebral column becomes more and more obscured. The brain is enclosed and protected in a cartilaginous **cranium** (Fig. 133, *Cr*), complete as regards its floor and side-walls but incomplete dorsally. The floor represents a continuation forwards of the series of vertebral centra, while the side walls in at least the hinder part represent a continuation forwards of the series of neural arches, but in so far at least as the adult Dogfish is concerned practically all trace of demarcation of the individual arches has disappeared.

At the sides of the vertebrate head are the three pairs of special sense-organs—the olfactory organ or nose, the eye, and the otocyst or ear—and each of these is enclosed in a protective capsule of cartilage. In the case of the two sense-organs which do not require to be freely movable, namely the olfactory organ and the otocyst, their protective capsules are firmly fused with the cartilaginous cranium—the **olfactory capsule** (Fig. 133, *olf*) in front and the **auditory capsule** (Fig. 133, *aud*) behind.

In addition to the true cranium with its sense-capsules there is present in the head region a characteristic arrangement of skeletal structures embedded in the wall of the buccal cavity and pharynx. These form the skeleton of the visceral arches—the masses of tissue lying between the successive visceral clefts. Primitively this skeleton consists of a series of hoop-like rods of cartilage embedded in the visceral arch near

its inner edge (Fig. 124, B, *v.a*) and bearing externally the slender tapering gill-rays (*g*) that support the thin part of the gill-septum. The originally continuous hoop-like cartilage becomes segmented into a number of pieces as may be seen in Fig. 133 (3, 4, 5, 6, 7). While in the case of the branchial arches the details of this differentiation are of minor importance, in the case of the mandibular and hyoid arches on the other hand some of them have an important bearing upon the morphology of vertebrates in general and therefore must be alluded to.

The first visceral arch or mandibular arch lies between the mouth

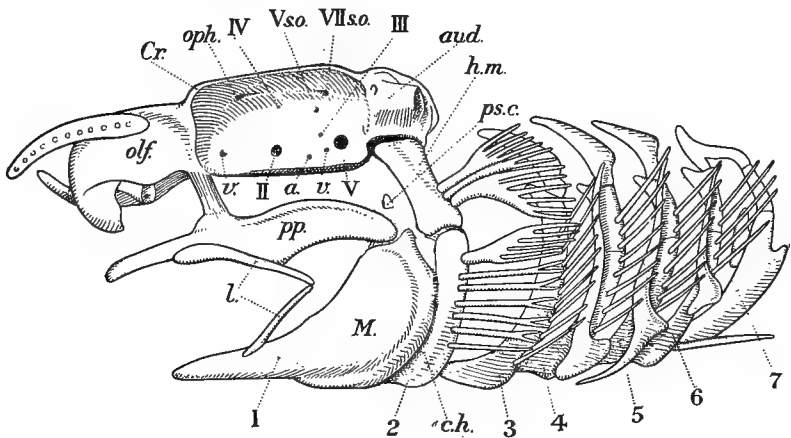

FIG. 133.

Cartilaginous skeleton of head and visceral arches of *Scyllium*, as seen from the left side. (After W. K. Parker.) *a*, Artery; *aud.*, auditory capsule; *c.h.*, ceratohyal; *Cr.*, chondrocranium; *h.m.*, hyomandibular; *l.*, labial cartilages; *M.*, Meckel's cartilage; *olf.*, olfactory capsule; *oph.*, olfactory capsule; *pp.*, palatopterygoid cartilage; *ps.c.*, pre-spiracular cartilage; *Vs.o.*, *VIIso.*, superficial ophthalmic nerves; *v.*, vein.

Roman numerals indicate foramina for cranial nerves; Arabic numerals, skeleton of visceral arches.

and the spiracle. The upper portion of the cartilage, next the cranium, is reduced to a functionless vestige—the prespiracular cartilage—lying just in front of the spiracle. The ventral portion on the other hand becomes much enlarged, supports the lower edge of the mouth with its teeth, and forms the lower jaw or **Meckel's cartilage** (Fig. 133, *M*). This Meckel's cartilage is of great interest as it is the primitive lower jaw of the vertebrate and is always present during early stages of development even in vertebrates in which the lower jaw of the adult is composed of bone and different in its morphological nature. The primitive upper jaw of the vertebrate—which is also seen typically in the Dogfish (Fig. 133, *pp*)

—consists of an outgrowth of cartilage at the dorsal end of Meckel's cartilage which spreads forward immediately over the mouth, supporting the upper set of teeth, and becoming segmented off so that its connexion with Meckel's cartilage forms a freely movable joint. There is thus brought about the hinged jaw-apparatus, enabling the mouth to be opened and closed, that is one of the characteristic features of the typical vertebrate.

The skeleton of the second or hyoid visceral arch—lying between the spiracle and the first branchial cleft—becomes modified to a much less extent. The main feature to notice is that its upper portion (hyomandibular) becomes considerably enlarged in correlation with the fact that it plays an important part in supporting the lower jaw which is bound to it by strong ligaments. Here we have a feature that is characteristic of several types of fish, and such a type of skull or head-skeleton—in which the hyoid arch takes part in the suspension of the jaws from the cranium—is termed **hyostylic**.

It will be noticed in Fig. 133 that the gill-rays attached to the hyoid arch are particularly large and strong and that most of them are branched. This is correlated with the fact that the visceral arch in question (II) is comparatively bulky, not being reduced to a thin septum as is the case with the arches further back in the series.

The two small cartilages "l" in Fig. 133 are termed labial cartilages: they are embedded in the edges of the mouth and are probably of no particular morphological significance.

The thin marginal parts of the fins are supported by the horny fin-rays mentioned on p. 298. The central layer of the thicker parts of the fins is occupied by cartilaginous rays, rods of cartilage, more or less regularly parallel, and most commonly subdivided into segments. In the ventral lobe of the caudal fin these cartilaginous fin-rays are simply the prolonged haemal spines and this hints to us that the cartilaginous rays of the median fin system in general have been evolved out of prolonged haemal or neural spines. Except in the ventral lobe of the caudal fin, however, the cartilaginous fin-rays are no longer in continuity with the arches of the vertebrae nor do they even correspond with them in number or position.

In the paired fins the cartilaginous fin-rays are attached at their inner ends to stout basal cartilages (*cf.* Fig. 164, D), and these in turn are jointed on to the limb-girdle—a stout bar of cartilage embedded in the body-wall which serves as a firm base of attachment for the skeleton of the fin. The pelvic fin is simplified in structure as compared with the pectoral and has only a single large basal cartilage instead of three.

The limb-girdle is seen in its least modified form in the **pectoral girdle** which in the adult Dogfish remains in a condition probably departing very little from that of the ancestral vertebrate. It forms a hoop-like cartilage, the right and left halves of which are continuous across the mesial plane ventrally but not dorsally. In each half a smooth joint-surface—the **glenoid** surface, serving for the attachment of the fin skeleton—serves as a landmark between the dorsal or **scapular** region and the ventral or **coracoid**.

In the **pelvic girdle** we distinguish similarly between a dorsal **iliac** and a ventral **ischio-pubic** region but in the Dogfish the former is reduced to a mere knob of cartilage—the girdle consisting simply of a transverse bar, representing the continuous ischio-pubic portions of the two sides, and carrying the limb skeleton close to its outer end.

As will have been gathered the main skeleton of the Dogfish is in the cartilaginous phase of evolution. In many parts it is given increased rigidity by the deposition of salts of lime in its intercellular matrix but this calcified cartilage never becomes replaced by true bone. Bony tissue is entirely confined to the placoid structures in the skin.

The Heart is in an early stage of its development simply an enlarged portion of the ventral vessel which, owing to its increase in length, its ends being fixed, has taken a somewhat **S-shaped** curvature. As development goes on certain portions of the primitive tubular heart become dilated and modified, with the result that in the completed heart four distinct chambers may be distinguished. Of these the posterior (Fig. 134, *s.v*), which receives the blood returned from the tissues of the body, is the **sinus venosus**. This opens forwards into a very large chamber with a thin wall like itself—the **atrium** (*a*). This opens downwards into a rounded chamber—the **ventricle**—characterized by the much greater thickness of its walls, composed of masses of muscle-fibres with **intervening chinks**. The ventricle opens in front into the **conus arteriosus** (*c*)—a slightly tapering tube with thick muscular walls which is continued forwards directly into the ventral aorta (*v.a*).

In the primitive tubular heart the contractions of its muscular walls by which the blood is propelled onwards are in the form of simple waves of contraction which pass along its length from behind forwards. As the tube becomes segmented into the four chambers the originally continuous wave becomes modified, and the portion of wall belonging to each chamber tends to contract by itself, the contraction of the several chambers still taking place in the original sequence, (1) sinus venosus, (2) atrium, (3) ventricle, and (4) conus.

The heart is rendered efficient as a pump by being provided with valves which ensure the blood passing always in the same direction and prevent **regurgitation**, i.e. the passing backwards of the blood in the wrong direction. Two of these, in the form of flaps opening downwards, are present in the atrioventricular opening. Six others—semilunar or **pocket-valves** (Fig. 134, *p.v.*)—are situated in the conus, arranged in two circles of three valves each. They may also be described as being arranged in three longitudinal rows of two valves each, and this is a better mode of description for it draws attention to an important morphological fact. The study of development shows that in the embryo each row of valves is represented by a longitudinal ridge. After the ventricle

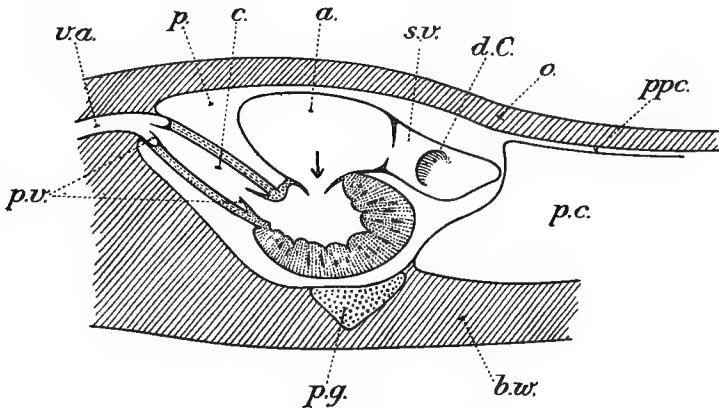

FIG. 134.

Diagrammatic sagittal (i.e. longitudinal, vertical, median) section through heart of a Dogfish (*Acanthias*). *a.*, Atrium; *b.w.*, body-wall; *c.*, conus arteriosus; *d.C.*, duct of Cuvier; *o.*, floor of oesophagus; *p.*, pericardial cavity; *p.c.*, peritoneal cavity; *p.g.*, pectoral girdle; *p.v.*, pocket-valves; *p.p.c.*, pericardio-peritoneal canal; *s.v.*, sinus venosus; *v.a.*, ventral aorta.

has contracted and driven the blood forwards the wall of the conus contracts and jams the three ridges together so as completely to obliterate the cavity and effectually prevent any sucking back of the blood into the ventricle as it expands. As development goes on the greater part of each ridge flattens out and disappears but two portions persist in a modified form as the two pocket-valves. Hence the fact that these are in line with one another. Each pocket-valve is shaped like a watch-pocket opening in a headward direction. As the blood passes forwards the pocket-valves flatten against the wall of the conus and interpose no resistance to the blood-stream, but the moment any sucking back of the blood commences the pockets open out and their edges coming together block the cavity.

This phenomenon observed during the development of the Dogfish and other vertebrates—the conversion of longitudinal ridges into rows of pocket-valves—appears to be the repetition of a process which has taken place during the evolution of this phylum, and one readily sees the physiological advantage of replacing a complicated muscular and nervous apparatus, with its greater liability to failure through pathological interference, by an apparatus purely mechanical and automatic.

The blood passing forwards from the heart is distributed throughout the tissues by a system of vessels to which the early anatomists gave the name **arteries**, meaning literally air-tubes, owing to the fact that at death the strongly muscular walls of these vessels commonly contract and drive the blood out of them so that when opened they contain only air. This expulsion of blood from the arteries at death gives them a characteristic pale colour in a dissection, in striking contrast with the deep colour of the veins which as a rule remain gorged with blood.

Before sketching out the arrangement of the main arteries in the Dogfish it is advisable to have a clear grasp of the general plan of arrangement of the main arterial trunks in the region of the vertebrate pharynx as these are of particular morphological importance (cf. Fig. 120, p. 293).

(1) Of aortic arches the normal number is six and these are denominated according to the visceral arch in which they are situated—I, II, III, IV, V, VI or Mandibular, Hyoid, First Branchial, Second Branchial, and so on. Where the arch is provided with gills the aortic arch is not a wide-open channel throughout but has intercalated in its course the capillary respiratory network. The ventral portion of the arch, supplying this network, is known as the **afferent** branchial vessel while the dorsal portion which drains the blood from the network is known as the **efferent** vessel. Of the aortic arches the first (Mandibular) is in most vertebrates a transitory structure in the embryo and soon disappears: the second (Hyoidean) also usually disappears or becomes much modified.

(2) There is a tendency for the main longitudinal vessels—dorsal and ventral aorta—to undergo a process of splitting from before backwards into right and left halves which with growth become displaced outwards so as to remain in comparative proximity to the gill-clefts. This is clearly an arrangement for the economy of tissue by diminishing the length of the afferent and efferent vessels.

(3) The paired vessels arising by this process of splitting are continued forwards into the head as the **carotid arteries**. The prolongations

of the paired portions of the ventral aorta are known as the ventral or **external carotids**: those of the paired portions of the dorsal aorta or **aortic roots** are known as the dorsal or **internal carotids**.

The arterial system of *Scyllium* is illustrated by Fig. 135. The ventral aorta supplies five pairs of afferent branchial vessels (II-VI) and of these V and VI have become approximated together at their origin from the ventral aorta while II and III have gone a step further and become completely fused throughout a great part of their length. Such fusions and alterations of position are common in the vascular system of vertebrates and are potent factors in bringing about differences between the vascular arrangements in closely allied creatures. The carotid and efferent systems of vessels in *Scyllium* undergo complicated changes during the course of development, leading to an arrangement in the adult which is of interest to specialists rather than to general students of vertebrate morphology and which therefore need not be further described here.

The efferent vessels pour their blood into the dorsal aorta which retains the unsplit condition and this is continued back, immediately ventral to the vertebral column, to the tip of the tail in which region of the body it is known as the **caudal artery** (Fig. 132, p. 316, *A*). The dorsal aorta by its branches supplies with oxygenated blood the whole of the trunk and tail regions. Numerous paired branches (**parietal arteries**) pass to the wall of the body, sending branches to the kidneys (**renal arteries**): a pair of **subclavian** arteries supply the pectoral fin, a pair of **iliac** arteries the pelvic fins.

Important unpaired branches pass out ventrally in the substance of the mesentery to supply the alimentary canal. Of these in the Dogfish there are four, the **coeliac** artery (liver, part of stomach, part of pancreas, anterior end of intestine), the **anterior mesenteric** (intestine, branches to genital organs), the **lieno-gastric** (spleen, part

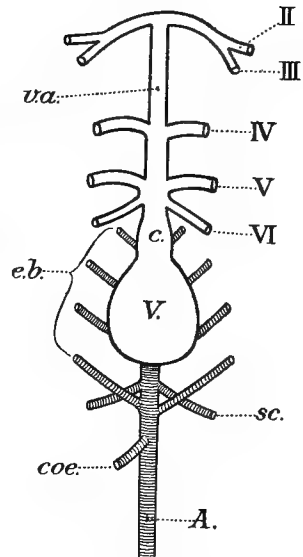

FIG. 135.

Illustrating the arterial system of the Dogfish (*Scyllium*). *A*, Dorsal aorta; *c*, conus arteriosus; *coe*, coeliac; *e.b.*, efferent branchials; *sc*, subclavian; *v.a.*, ventral aorta. The roman numerals indicate the ventral portions of the several aortic arches (afferent branchials).

of stomach, part of pancreas) and the **posterior mesenteric** (rectal gland).

The main arterial trunks divide up into finer and finer branches and the terminal twigs lead into the network of capillaries which traverses

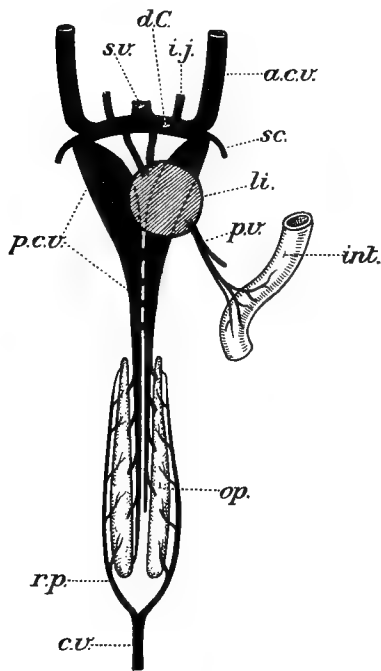

FIG. 136.

Diagram illustrating the arrangement of the main venous trunks in a Dogfish (*Scyllium*). *a.c.v.*, Anterior cardinal; *c.v.*, caudal; *d.C.*, duct of Cuvier; *i.j.*, inferior jugular; *int.*, intestine; *li.*, liver; *op.*, opisthonephros; *p.c.v.*, posterior cardinal; *p.v.*, hepatic portal; *r.p.*, renal portal; *s.v.*, sinus venosus; *sc.*, subclavian. The hepatic veins are indicated as two simple vessels passing from liver to sinus venosus, their dilatation and approximation not being shown.

all the living tissues of the body and serves to bring the circulating blood into intimate relation with the living protoplasm. From the network of capillaries the blood is drained off and returned to the heart by the system of vessels known as **veins**. The venous system of the adult Dogfish is of greater morphological importance than the arterial, for in its general plan it shows an arrangement which is clearly repeated in the young embryonic stages of the higher vertebrates and which may therefore safely be regarded as very primitive.

of the blood circulating through the capillary network of the kidney comes to it by the **renal portal** (*r.p.*), the two renal portals being formed by the bifurcation of the **caudal vein** (*c.v.*) or main vein of the tail region which lies immediately underneath the caudal artery (Fig. 132, p. 316, *V*).

The blood from the intestine reaches the heart by a special set of

The sinus venosus is continued outwards on each side as a large vein—the **duct of Cuvier** (Fig. 136, *d.C.*), named after Cuvier the great French pioneer of Comparative Anatomy. The duct of Cuvier conveys to the heart the blood from a large **anterior cardinal vein** (*a.c.v.*) which extends back from the head region dorsal to the gill-clefts, and a **posterior cardinal vein** (*p.c.v.*) which drains the blood forwards from the kidney. By far the greater part

The sinus venosus is continued outwards on each side as a large vein—the **duct of Cuvier** (Fig. 136, *d.C.*), named after Cuvier the great French pioneer of Comparative Anatomy. The duct of Cuvier conveys to the heart the blood from a large **anterior cardinal vein** (*a.c.v.*) which extends back from the head region dorsal to the gill-clefts, and a **posterior cardinal vein** (*p.c.v.*) which drains the blood forwards from the kidney. By far the greater part

veins other than those mentioned so far. The numerous small veins which collect the blood from the intestinal wall join together to form larger and larger trunks until at last the whole blood-stream is collected together in a single great vessel known as the hepatic portal vein, or shortly the **portal** vein (Fig. 136, *p.v.*). This passes forwards to the liver where it breaks up into branches supplying the capillary network of that organ. From this there pass away in turn efferent veins which eventually join up to form a pair of **hepatic** veins opening into the sinus venosus. It is thus clear that the blood collected from the intestine, which after a meal is laden with absorbed food material, has, before it reaches the heart, to pass through the capillary network of the liver, and it is while it does so that the carbohydrate is extracted from it to be stored up temporarily, as has already been mentioned, in the form of glycogen.

Apart from the above-mentioned features of the venous system, which are all of primary importance, a number of other details will be gathered from an inspection of the diagram. In *Scyllium* the anterior cardinal, posterior cardinal and hepatic veins are greatly dilated and are commonly spoken of as sinuses. In the case of the two last mentioned the right and left sinus are in contact with one another along the mesial plane and their cavities communicate freely through gaps in the intervening partition. In *Scyllium* the anterior cardinal sinus extends into the orbit so that the eyeball and its muscles are bathed with blood. This orbital sinus communicates with its fellow by a narrow vein through the floor of the skull (Fig. 133, posterior opening marked *v*). There opens into the duct of Cuvier on each side a small "inferior jugular" vein (*i.j*) which comes from the floor of the mouth along the outer side of the pericardiac cavity. Into the posterior cardinal sinus there open (1) at its extreme front end the **subclavian** vein (*sc*) from the region of the pectoral fin, and (2) further back the **lateral** vein from the body-wall and (3) still further back and ventrally the **genital** sinus from the ovary or testis.

Within the system of vessels there circulates the blood. This consists of a watery fluid (**plasma**) which carries in suspension cells belonging to two very different types. The first of these (**leucocytes**, "white corpuscles") are small amoebocytes: the others (**erythrocytes**, "red corpuscles") are cells which have lost their amoeboid character, the cytoplasm having become stiffened into the form of a flattened elliptical disc, and are impregnated with the remarkable iron-containing pigment haemoglobin which gives the red colour to the blood. This substance is remarkable above all for its peculiar affinity for oxygen. In the presence of oxygen it immediately combines with it to form a compound—oxyhaemoglobin—distinguished by its brighter red colour. The

combination of the oxygen and the haemoglobin is a very loose one and is readily broken up. This chemical peculiarity of haemoglobin adapts it admirably to the function which it performs in the body, that of serving as a vehicle for the conveyance of oxygen throughout the living tissues. Passing through the capillary network of the respiratory organ the haemoglobin becomes oxidized by oxygen from the external medium and the blood as a consequence takes on the bright scarlet characteristic of arterial blood. Each corpuscle whirled onwards in the blood-stream retains its complement of oxygen until at last it is brought, in the capillary network, into the immediate proximity of tissue hungry for oxygen: there the combination is dissolved, the oxygen is retained by the tissue, while the haemoglobin is borne away in the now dark-coloured venous blood, eventually to reach again the respiratory surface where the cycle is started afresh.

The blood serves also for the transport of other substances, such as food materials, and carbon dioxide and other excretory products, but in their case it is not known what special mechanisms, if any, exist for the purpose.

The walls of the blood-vessels are not absolutely impermeable. Plasma oozes out and leucocytes wander out by their own activity. The colourless blood so constituted is known as **lymph**: it fills all the chinks of the body and is in immediate relation to all the living protoplasm: it forms the internal medium in which the various cells live. The lymph is constantly being returned to the blood by definite channels known as **lymphatics**, which open into the venous system at definite points, and the walls of these may be in places thickened and muscular and form rhythmically contractile **lymph hearts**—but in the Dogfish the arrangements of this lymphatic system have not up to the present been completely mapped out.

Before leaving the vascular system the **spleen** must be mentioned. This is in the Dogfish a large organ of a dark red colour fitted round the bend of the stomach. It is really a kind of sponge-work, the meshes of which are filled with blood. Its precise functional significance is not yet understood.

The activities of the various organs of the vertebrate are controlled and co-ordinated through the agency of a very complicated nervous system.

The central nervous system consists fundamentally of a tube—the **neural tube**—with very thick walls and a very narrow cavity (central canal). The greater part of the length of the tube is comparatively

slender and is known as the **spinal cord** while the portion at the anterior end is much enlarged and forms the **brain**.

The neural tube originates as a localized thickening of the ectoderm along the dorsal side of the embryo known as the **medullary plate**. This grows actively and, its central portion being held down by adhesion to the notochord, its edges curve upwards and form the **medullary folds**, bounding a trough-like **neural groove**. With continued growth the folds arch in towards one another so that the opening of the groove narrows to a slit and eventually disappears, the edges of the folds undergoing complete fusion. In this way the neural groove is converted into the closed **neural tube** which soon loses its connexion with the external ectoderm.

An important point to appreciate is that the surface of the central nervous system which faces inwards towards the central canal is that which originally was part of the external surface of the ectoderm.

The spinal cord in its fully developed condition is still tubular in form but its cavity, the central canal, is relatively minute while its wall has become enormously thickened and greatly complicated in structure. The inner portion is crowded with ganglion cells ("grey matter") while the outer part consists for the most part of longitudinally running nerve-fibres ("white matter").

From the spinal cord there pass off at intervals—a pair corresponding to each pair of myotomes—large bundles of nerve-fibres known as the **spinal nerves**. Each of these arises from the spinal cord by two roots, a dorsal and a ventral (Fig. 137, *d.r* and *v.r*). The dorsal root shows a distinct swelling on its course, the **spinal ganglion** (*s.g*). Each root is composed of nerve-fibres but these show important and characteristic differences in the two roots. A fibre belonging to the ventral root if traced into the spinal cord will be found to originate in a ganglion-cell with branched projections from its body situated towards the ventral side of the spinal cord (Fig. 137, *M*). In the opposite direction such a nerve-fibre passes outwards along the nerve trunk and eventually terminates in a muscle-fibre (*m*): it is clearly a motor or efferent nerve-fibre.

A nerve-fibre belonging to the dorsal root on the other hand is found to have a spindle-shaped ganglion-cell (Fig. 137, *S*)—pear-shaped in the higher vertebrates—intercalated on its course and situated in the spinal ganglion. Peripherally this nerve-fibre is connected not with a muscle-fibre but with a sensory nerve-ending in the skin or elsewhere. It is clearly a sensory or afferent fibre. Traced inwards from the ganglion-cell it is found to enter the spinal cord and to be continued in a T-like

manner up and down the spinal cord. From the longitudinal portion of the fibre cross-pieces (collateral fibres—Fig. 137, *col*) pass off at intervals, which divide up into fine branches in intimate relation with a motor ganglion-cell. The question whether there is actual continuity of substance between the terminal twigs of the collateral and the cytoplasm of the motor-cell or merely intimate contact is a particular case of one of the most disputed problems regarding the structure of the vertebrate body. While the obvious evidence in the way of observed fact has up to the present failed to give a clear demonstration of such continuity there is still a minority of investigators, including the present writer,

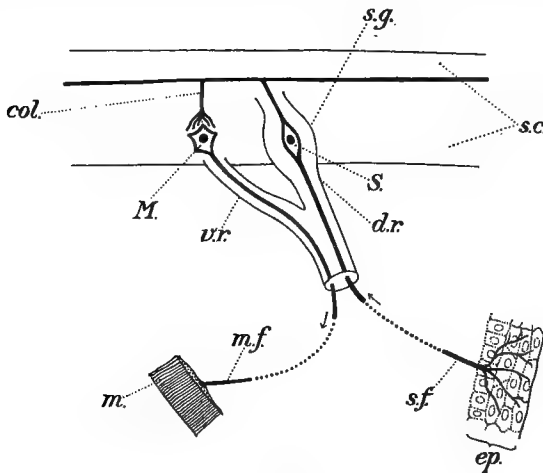

FIG. 137.

Diagram showing the relations of a spinal nerve to the spinal cord. *col*, Collateral branch of sensory fibre; *d.r.*, dorsal root; *ep.*, epidermis; *M*, motor ganglion-cell; *m.*, muscle-fibre; *m.f.*, motor-fibre; *S*, sensory ganglion-cell; *s.c.*, spinal cord; *s.f.*, sensory fibre; *s.g.*, spinal ganglion; *v.r.*, ventral root.

who regard such continuity as probably existing though it may be almost impossible to demonstrate.

The arrangement of ganglion-cells and nerve-fibres just described is of physiological interest inasmuch as it affords us a glimpse of the type of nervous mechanism concerned in the production of **reflex movements**—involuntary and immediate responses in the form of movement to particular sensory stimuli. A glance at the diagram will show how a sensory message from the skin may readily influence the motor-cell by way of the collateral and so arouse it to its particular form of activity, that of sending out a motor impulse to bring about contraction of the muscle-fibre.

The brain of the vertebrate is for descriptive purposes divided into the undermentioned regions, but it must be distinctly understood that the brain is a fundamentally continuous whole and that the division into the portions named is purely secondary, having come about with the gradual specialization of particular parts of the brain for particular functions.

CEREBRUM	{	HEMISPHERES. THALAMENCEPHALON. MESENCEPHALON.
RHOMBENCEPHALON	{	CEREBELLUM. MEDULLA OBLONGATA.

The **MEDULLA OBLONGATA** (Fig. 138, A, *m.o*) is a direct forward prolongation of the spinal cord, from which it differs in three well-marked features: (1) Its diameter is greater, (2) the portion of central canal within it is greatly expanded forming the **Fourth Ventricle**, (3) its roof is degenerate, being a thin membrane devoid of ganglion-cells and nerve-fibres and having closely apposed to its outer surface a rich network of blood-vessels—a so-called **choroid plexus**. Physiologically the great importance of the medulla oblongata lies in the fact that in its side-walls and floor are situated the masses of ganglion-cells which form the special nerve-centres (“nuclei”) belonging to those nerves of the head region which are of the greatest importance to life.

The **CEREBELLUM** (Fig. 138, A, *c*) is simply the front portion of the roof of the fourth ventricle which, instead of degenerating into a membranous condition as does the rest, forms a thick transverse band stretching across from side to side. As development goes on this transverse band undergoes very active growth in an antero-posterior direction, with the result that it bulges outwards and forms in the adult a very large and conspicuous portion of the brain, overlapping the brain regions immediately in front and immediately behind it. Functionally the cerebellum appears to be concerned especially with the co-ordination of the contraction of the various muscles of the body, i.e. with securing that the various muscles contract in such a way as to work together for the production of appropriate movement of the body as a whole.

Of the **MESENCEPHALON** (“mid-brain”) the most conspicuous portions are two rounded bulgings of its roof (Fig. 138, A, *op.l*)—the **optic lobes**, partially hidden in dorsal view by the cerebellum—which contain ganglion-cells concerned with the sense of sight.

The **THALAMENCEPHALON** (Fig. 138, A, *th*) possesses this feature in common with the medulla oblongata that its roof is, at least in parts,

degenerate and membranous, with a choroid plexus of blood-vessels closely apposed to it. Its cavity, the "third ventricle," is a narrow vertical slit, on each side of which is a thick lateral wall known as the optic **thalamus** and composed for the most part of sensory nerve-fibres on their way from the eye towards the optic lobe.

From the posterior portion of the roof of the thalamencephalon there projects a slender tubular outgrowth which stretches forwards and ends blindly close to the skin of the dorsal surface a little in front of the hemisphere region.

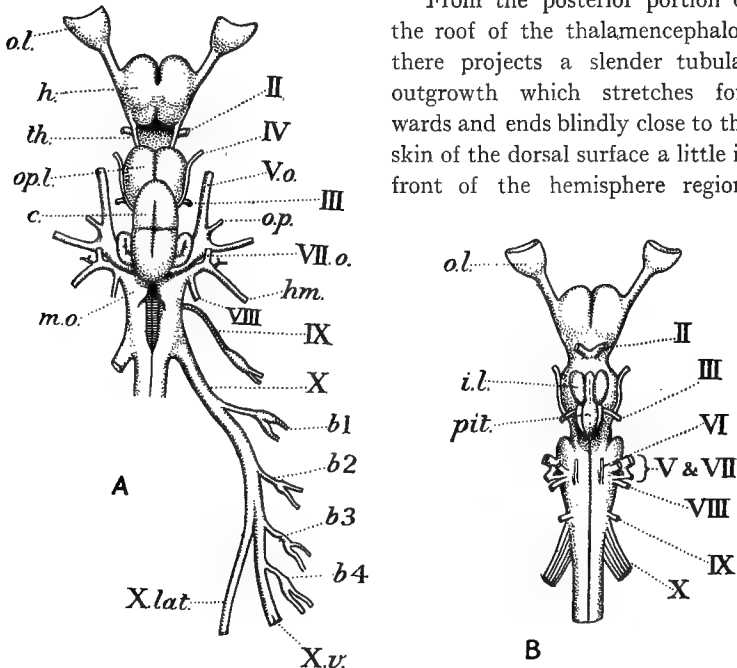

FIG. 138.

Brain of *Acanthias* with the cranial nerves (after Purser). *c*, Cerebellum; *h*, hemisphere region; *hm*, hyomandibular branch of VII; *i.l.*, inferior lobe; *m.o.*, medulla oblongata; *ol.*, olfactory bulb; *o.p.*, deep ophthalmic branch of V; *opl.*, optic lobe; *pit.*, pituitary body; *th*, thalamencephalon. II, Optic nerve; III, oculomotor; IV, pathetic; V, trigeminal, V.o, its superficial ophthalmic branch; VI, abducent; VII, facial, VII.o, its superficial ophthalmic branch; VIII, auditory; IX, glosso-pharyngeal; X, vagus, *b1*, *b2*, etc., its branchial branches, *X.lat.*, its lateral line branch, *X.v.*, its visceral branch.

This is the **pineal organ**—of great interest from the fact that in most vertebrates it functions as a ductless gland while in a few members of the group it takes the form of a third eye. It will be referred to in this connexion later on.

The floor of the thalamencephalon dips downwards into a large backwardly projecting pocket—the **infundibulum**. The side-walls of this are thickened to form the **inferior lobes** (Fig. 138, B, *i.l.*) while its terminal

portion grows out into irregular projections surrounded by blood-sinuses and forming the **saccus vasculosus**.

Attached to the ventral surface of the infundibulum is the **pituitary body** (Fig. 138, B, *pit*), elongated in shape in an antero-posterior direction. This, although in the adult condition it appears to be a part of the brain, is in reality of quite independent origin. It originates as a pocket-like ingrowth of the ectoderm on the ventral side of the head. This grows inwards underneath the brain and presently becomes isolated from the outer skin, forming a closed sac immediately underlying and apparently forming part of the infundibulum. Whereas the pituitary body would appear to have been originally a gland opening either into the buccal cavity or close in front of it, its function is in the typical modern vertebrate that of a ductless gland. Its contribution to the internal medium is clearly of importance since in the higher vertebrates disease of the pituitary is accompanied by disturbances of the general metabolism which find their expression in peculiarities of growth (acromegaly) and eventually in serious disease, and in Tadpoles it has been found that the absence of its internal secretion paralyses the activity of the chromatophores of the skin.

The **HEMISPHERES** are in the typical vertebrate a pair of bulging outgrowths from the wall of the thalamencephalon close to its front end. Each of them contains a cavity, the **lateral ventricle**, which is simply a prolongation of the third ventricle and remains throughout life connected with it by a small opening, the **Foramen of Monro**, named after Monro ("secundus") of Edinburgh, one of the great pioneers of vertebrate anatomy. The wall of the hemisphere contains ganglion-cells especially associated with the sense of smell and it is regarded as a portion of the brain which has been evolved specially in connexion with that sense.

The most marked peculiarity of the Hemisphere region of the Dogfish (Fig. 138, A, *h*) is that in this animal the paired condition is obscured, the two hemispheres being continuous across the mesial plane, instead of being separated by a cleft as is the case with most vertebrates.

The portion of hemisphere wall lying next to the olfactory organ or organ of smell comes to bulge out into a somewhat T-shaped olfactory lobe. The cross-piece of the T contains the ganglion-cells immediately connected with the organ of smell and is known as the **olfactory bulb** (Fig. 138, *o.l*) while the narrower stalk (olfactory or bulbo-olfactory tract) consists mainly of nerve-fibres passing back to a second set of ganglion-cells within the body of the hemisphere (**olfactory tubercle**).

The various subdivisions of the brain as enumerated above are commonly grouped into either three or two primary divisions. The older division into three—**FORE-BRAIN** (=Thalamencephalon or Primary fore-brain + Hemispheres or Secondary fore-brain), **MID-BRAIN** (=Mesencephalon) and **HIND-BRAIN** (=Cerebellum + Medulla oblongata)—rests mainly on the fact that in some of the vertebrates of which the development has long been familiar, e.g. the Birds, the brain becomes at a very early period of its development marked off by slight constrictions into portions lying one behind the other which give rise to fore-, mid- and hind-brain respectively. The more modern custom of regarding the primary subdivisions of the brain as two in number—Cerebrum and Rhombencephalon—is based especially on the work of anatomists but it is also supported by the embryology of some of the more primitive vertebrates in which the Cerebrum becomes marked off from the Rhombencephalon long before it shows a subdivision into fore-brain and mid-brain.

From the brain there pass off ten pairs of **cranial nerves** which are found with hardly any modification through the series of vertebrates right up to the highest. They are as follows :

- I. OLFACTORY.
- II. OPTIC.
- III. OCULOMOTOR.
- IV. PATHETIC.
- V. TRIGEMINAL :
 1. Ophthalmic.
 2. Maxillary.
 3. Mandibular.
- VI. ABDUCENT.
- VII. FACIAL :
 1. Ophthalmic.
 2. Buccal.
 3. Palatine.
 4. Hyomandibular.
- VIII. AUDITORY.
- IX. GLOSSO-PHARYNGEAL.
- X. VAGUS :
 1. Visceral.
 2. Lateral.

OLFACTORY.—The First Cranial nerve consists of nerve-fibres passing from the organ of smell to the ganglion-cells of the olfactory bulb. It is a purely sensory nerve, devoted entirely to the sense of smell. In the

Dogfish it can hardly be said to exist as a discrete nerve, owing to the olfactory organ and olfactory bulb being practically in contact, the diffuse nerve-fibres passing across directly from one to the other.

OPTIC (Fig. 138, II).—The Second Cranial nerve is also purely sensory. It is the nerve of sight and conveys impulses from the eye in towards the brain. It is a very thick nerve and passes into the floor of the thalamencephalon. In some fishes the right and left nerves cross like an X, the nerve from the right eye passing towards the left side of the brain and conversely. In the Dogfish and in the great majority of vertebrates the crossing (**optic chiasma**) is of a much more complicated character, some fibres passing from the eye to the opposite side of the brain, some to the same side of the brain: others pass from one eye to the other eye, and still other fibres pass outwards in the one root from the brain and then double back into the brain by the other root.

OCULOMOTOR, ABDUCENT, PATHETIC.—The Third, Fourth and Sixth cranial nerves may conveniently be taken together. They are all motor nerves which supply the muscles of the eyeball. The eyeball of the vertebrate is contained within a socket—the orbit—in which it can be freely moved so as to direct it in one direction or another. These movements are carried out by muscles one end of which arises from the wall of the orbit while the other is attached to the surface of the eyeball. Throughout the whole series of vertebrates with functional eyes the muscles attached to each eyeball are precisely the same and are six in number. Four of these radiate out from a point on the inner wall of the orbit to opposite sides of the eyeball. These are the **Recti** and they are individually named, from their position in the human body, External (Fig. 139, *e.r.*—in the Dogfish posterior in position as the eye looks outwards instead of forwards), Internal (*i.r.*), Superior (*s.r.*) and Inferior Rectus (Fig. 139, B, *inf.r.*). The other two muscles pass from the anterior wall of the orbit to the upper and lower side of the eyeball respectively and are known as the **Superior Oblique** (*s.o.*) and the **Inferior Oblique** (Fig. 139, B, *i.o.*).

PATHETIC (Fig. 138, IV).—The Fourth cranial nerve serves simply as the motor nerve for the Superior Oblique muscle. It is accordingly of relatively small size and is peculiar among the cranial nerves in that it arises from the *roof* of the brain—in the angle between cerebellum and mesencephalon.

ABDUCENT (Fig. 138, B, VI).—The Sixth nerve similarly is the motor nerve of a single eye-muscle—the External Rectus. It also is of very small size: it arises from the ventral surface of the medulla oblongata.

OCULOMOTOR (Fig. 138, III).—The Third nerve supplies the four remaining eye-muscles—Superior, Inferior and Internal Rectus and the Inferior Oblique. It arises from the mesencephalon towards its ventral side.

TRIGEMINAL (Fig. 140, V).—The Fifth nerve is the largest of the cranial nerves in the Dogfish. It is given the name Trigeminal in vertebrates from the characteristic fact that it divides into three main branches, known as the Ophthalmic (I), Maxillary (II), and Mandibular (III) divisions of the nerve.

Of these branches the ophthalmic passes forwards through the cavity of the orbit and is distributed eventually to sensory cells in the skin on the dorsal side of the snout. In *Acanthias* it divides into two, a ventral

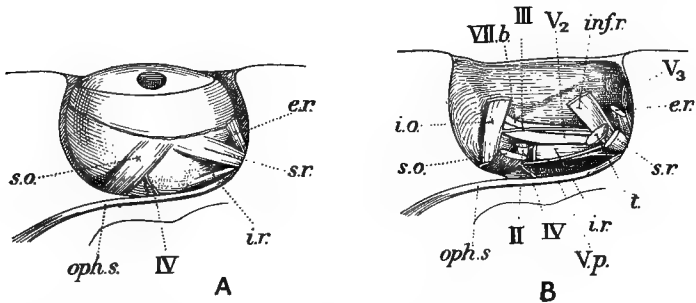

FIG. 139.

Dogfish (*Acanthias*). View of right orbit with the eyeball and its muscles. A, eyeball in position; B, eyeball removed. *e.r.*, External rectus; *i.o.*, inferior oblique; *i.r.*, internal rectus; *inf.r.*, inferior rectus; *oph.s.*, superficial ophthalmic nerves; *s.o.*, superior oblique; *s.r.*, superior rectus; *t.*, supporting table for eyeball; II, optic nerve; III, oculomotor (branch to inferior oblique); IV, pathetic; V, trigeminal (*p.*, deep ophthalmic branch; *z.*, mandibular branch; *3.*, maxillary branch); VII*b.*, facial (buccal branch).

deep ophthalmic branch (Fig. 140, *Vd.o*) which passes forwards beneath the superior rectus muscle and a **superficial ophthalmic** (Fig. 140, *Vs.o*) lying more dorsally, along the mesial wall of the orbit, and enclosed in a common sheath with the similarly named branch of VII. In *Scyllium* there is no separate deep ophthalmic branch.

The maxillary (Fig. 140, *Vmx*) and the mandibular (*Vmn*) divisions of the trigeminal, which in *Scyllium* are fused together into a common trunk for some distance, pass respectively to the upper and to the lower side of the mouth. The maxillary, purely sensory, is distributed to the skin of the roof of the mouth and the ventral side of the snout, while the mandibular carries the motor fibres for the muscles connected with the lower jaw together with sensory fibres for the same region.

The trigeminal nerve issues from the brain at the side of the medulla oblongata near its anterior limit (Fig. 138, B).

FACIAL (Fig. 140, VII).—The Seventh nerve also arises from the side of the medulla oblongata, close behind the Fifth (Fig. 138, B). The main stem of the nerve (**Hyomandibular**, Fig. 140, VII hm) passes out towards the spiracle, over which it forks very much in the same way as the main stem of the trigeminal does over the edge of the mouth, except that here the anterior branch is greatly reduced. This trunk is mainly motor, supplying various muscles connected with the lower jaw and hyoid arch. It is of evolutionary interest from the fact that in man the muscles

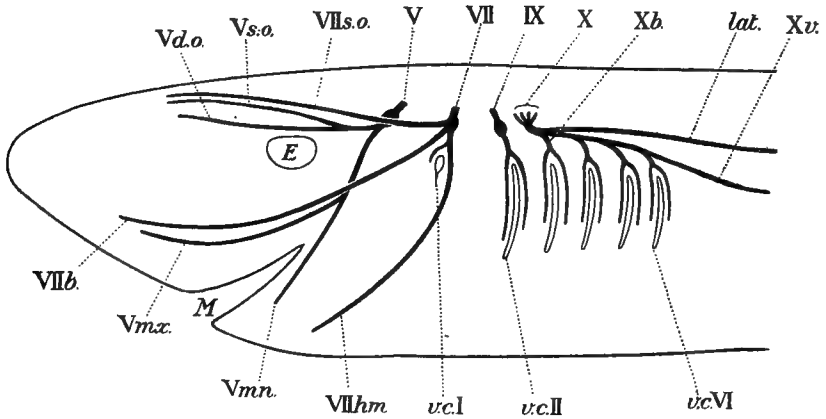

FIG. 140.

Diagram illustrating the arrangement of certain of the cranial nerves in the Dogfish. *E*, eye; *lat.*, lateral line nerve; *M*, mouth; *v.c.*, visceral cleft. *V*, Trigeminal; *Vd.o.*, deep ophthalmic branch; *Vmn.*, mandibular branch; *Vmx.*, maxillary branch; *Vs.o.*, superficial ophthalmic branch; *VII*, Facial; *VIIb.*, buccal branch; *VIIhm.*, hyomandibular branch; *VIIs.o.*, superficial ophthalmic branch; *IX*, Glosso-pharyngeal; *X*, Vagus; *Xb.*, first branchial branch; *Xv.*, visceral branch.

supplied by this nerve have become spread over the face so that it controls the complicated musculature of facial expression.

The slender **Palatine** branch (not shown in Fig. 140) passes diagonally outwards and forwards across the floor of the orbit: it is purely sensory and is distributed to the roof of the mouth.

The two remaining branches are associated with remarkable sense organs of the skin belonging to the lateral line system (see below, p. 345).

The **Buccal** branch (Fig. 140, VII b) is distributed along with the maxillary division of the trigeminal, from which it is indistinguishable through a great part of its length, and is the nerve of the organs of the lateral line system on the lower surface of the snout and below the eye.

The **Superficial Ophthalmic** branch (Fig. 138, A, VII σ and Fig. 140, VII $s.o$) runs along the inner wall of the orbit, dorsal to the similarly named branch of the trigeminal which it accompanies in its distribution. In *Acanthias*, as already indicated, the two superficial ophthalmic nerves (V and VII) are enclosed in a common sheath. It innervates the lateral-line sense-organs on the dorsal surface of the snout.

AUDITORY (Fig. 138, VIII).—The Eighth nerve is the nerve of hearing. It is formed of branches from the various parts of the otocyst which are collected into a short thick trunk and enters the side-wall of the medulla oblongata in close proximity to the Fifth and Seventh nerves.

GLOSSO-PHARYNGEAL (Figs. 138 and 140, IX).—The Ninth nerve arises from the side of the medulla oblongata, well down towards the ventral surface and some distance behind the auditory. It passes outwards and backwards through the cartilage of the auditory capsule and forks over the first ordinary gill-cleft, just as the hyomandibular does over the spiracle. Its anterior branch is sensory while the posterior branch is also motor, supplying muscles connected with the first branchial arch.

VAGUS (or Pneumogastric—Figs. 138 and 140, X).—The Tenth nerve gets its name Vagus (wandering) from the wide extent of its distribution; although a cranial nerve it is not confined to the head but extends far into the trunk region. It arises from the side of the medulla oblongata by a number of roots which converge in a fan-like manner to form a common trunk. This (**visceral trunk**—X v) passes back supplying the stomach and neighbouring parts of the alimentary canal and also the heart. Four **branchial** branches (Fig. 138, b_1 , b_2 , etc.) pass off from the visceral trunk to supply the walls of the last four gill-clefts: each forking over the cleft in precisely the same manner as the glosso-pharyngeal over the first cleft. This fact taken in conjunction with the numerous roots leads to the conclusion that the vagus really represents not a single cranial nerve but a series of nerves, each equivalent to the glosso-pharyngeal, which have become fused together.

In addition to these branches there is the **lateral** branch (Fig. 140, *lat*) which arises by its own root dorsal to the root of the glosso-pharyngeal. It accompanies the visceral branch for some distance and then passes backwards along the side of the body to the tip of the tail, lying deeply embedded in the muscle and giving off at intervals twigs to the sense-organs of the lateral line.

In the fact that it is the sensory nerve of the lateral-line organs the lateral branch of the vagus recalls the buccal and superficial ophthalmic divisions of the facial, and the interesting discovery has been made that

all these nerves are connected with a common nerve-centre lying in the medulla oblongata and in close relation to the centre of the auditory nerve. Physiologically they form a group of nerves by themselves, and it is quite conceivable that, as some zoologists believe, the nerve-fibres composing them formed originally either an independent cranial nerve or a portion of the auditory but have in the course of evolution come to be subdivided up and incorporated in other cranial nerves.

We may take it that in the Vertebrata as in other groups the skin was primitively provided with sensory cells scattered throughout its ectoderm: and in this phylum as elsewhere we find special aggregations of such sensory cells to form sense-organs devoted to the perception of some special type of impression from the outer world. The simplest of these organs of special sense in the Dogfish is the olfactory organ or organ of smell.

OLFACTORY ORGAN.—This organ commences in the embryo as a slightly thickened patch of ectoderm on the ventral surface of the head on each side. This thickening becomes gradually sunk down beneath the general surface, its opening becoming narrowed but never completely closed. The ectoderm lining the cavity so formed becomes crowded with sensory cells and a great increase in the area of the sensory epithelium is obtained by its projecting into the cavity in the form of a number of thin, almost leaf-like, folds. In *Scyllium*, though not in *Acanthias*, the olfactory organ is connected with the mouth by a deep groove, the edges of which almost meet.

EYE.—While the olfactory organ is relatively simple the eye on the other hand reaches the utmost extreme of complexity in its structure, and this fact is not surprising if the marvellous function performed by the eye is borne in mind—the formation in the first place of an optical picture of the external world and then the translating of this into symbols composed of nerve impulses which can be duly interpreted by the brain so as to form a correct mental picture.

The eye of the vertebrate is of the camera type, comprising the two essential and primary components: a lens for the formation of the image and a sensitive surface—the retina—for the reception of that image.

The lens (Fig. 141, *l*) is composed of a mass of metamorphosed cells, the protoplasm of which is converted into somewhat horny material of glassy transparency and is in the Dogfish as in many other creatures inhabiting water—a comparatively highly refracting medium—practically spherical in shape.

The retina (Fig. 141, *R*), the function of which is the translation of

the optical image thrown on it by the lens into terms of nerve-impulses, is of extraordinarily complicated structure and the details even in our present imperfect knowledge of them are too complex to be gone into in an elementary text-book. The general structure is as follows. There is a layer of sensory—in this case **visual**—cells of the slender columnar form so common in sensory cells. Instead of an ordinary sensory hair each of these carries at its free end a rod—a column of highly specialized cuticular material, alternate transverse layers of which present a dimmer and a more transparent appearance. It is apparently the substance of this rod, composed of peculiarly modified cytoplasm, that possesses the extraordinary property of converting waves of light into living impulses. The layer of visual cells is underlaid by a thick mass of ganglion-cells, of various different types and linked up together in highly complicated fashion, and then eventually, on the surface of this furthest from the rods, there emerge the nerve-fibres which collect together to form the optic nerve. The complicated mass of ganglion-cells and visual cells is supported by special straight cells, with much frayed out cell-body composed of stiff cytoplasm, which traverse the retina at intervals in a direction perpendicular to its surface. Closely abutting on the face of the retina bearing the rods is a layer of cells (**pigment layer**), polygonal in shape as seen in surface view, their cytoplasm laden with black melanin pigment. These cells during exposure to bright light push out numerous pigment-laden pseudopodia into the spaces between the rods while in faint light these are withdrawn.

One at first sight extraordinary feature of the percipient part of the vertebrate retina is that it is reversed in position from what we should expect—the visual cells with their rods pointing not towards the lens, i.e. in the direction from which the stimulus comes, but away from it (Fig. 141, *r*). It follows that the light rays in order to reach the rods have first to traverse all the rest of the retina, and in accordance with this the retina of the vertebrate is absolutely transparent.

The lens and retina are enclosed within the eyeball—a protective capsule composed of very tough connective tissue. The greater part of this has a characteristic white opaque appearance and is known as the **sclerotic** (Fig. 141, *s*). It contains in the Dogfish a layer of cartilage. On its outer side a circular portion of the capsule loses its opacity and becomes absolutely clear and transparent—the **cornea** (Fig. 141, *C*). The space between the sclerotic and the pigment layer of the retina is occupied by a spongy layer known as the **choroid** (Fig. 141, *ch*), very rich in blood-vessels and laden with melanin pigment. The outer edge of the cup-like arrangement formed by the choroid with its lining of

retina is bent inwards to form the **iris** (Fig. 141, *i*) a kind of diaphragm surrounding a circular opening the **pupil** (*p*) behind which the lens is situated.

The inner layer of the choroid is in the Dogfish laden with silvery-looking flakes of guanin: this strongly reflecting layer is the **tapetum**. A similar layer on the outer side of the choroid is the **argentea**: it is

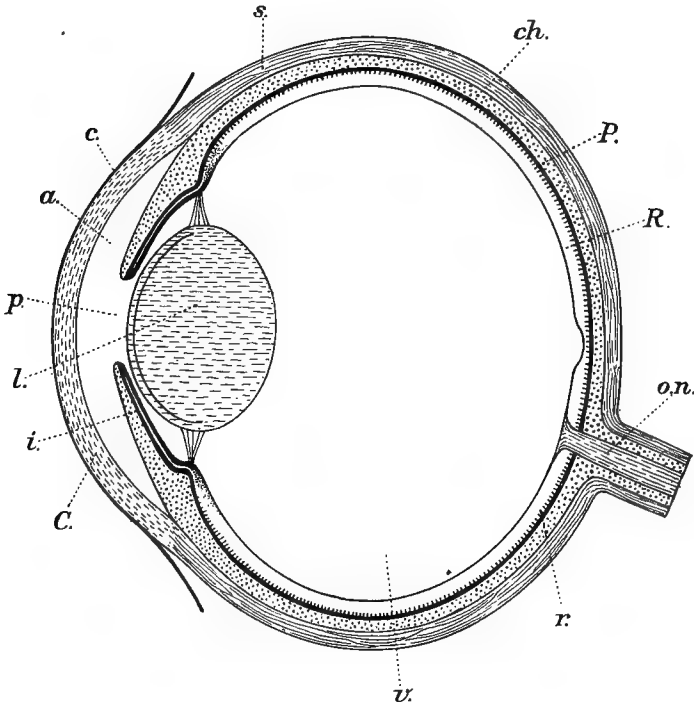

FIG. 141.

Illustrating the structure of the eye of a vertebrate. *a*, Aqueous humour; *c*, conjunctiva; *C*, cornea; *ch*, choroid; *i*, iris; *l*, lens; *o.n.*, optic nerve; *P*, pigment layer; *p*, pupil; *R*, retina; *r*, layer of rods; *s*, sclerotic; *v*, vitreous body.

this which gives the shining metallic appearance to the iris as seen from without.

The eyeball retains its shape owing to its cavity being tensely filled—in the portion lying between iris and lens on the one hand and cornea on the other—with a watery fluid: the **aqueous humour** (Fig. 141, *a*)—and in the larger portion lying between lens and retina with a clear jelly—the **vitreous body** (Fig. 141, *v*)—containing a few scattered cells.

The eyeball is contained within the orbit. Its somewhat flattened

outer side is in close contact with the external epidermis which is continued over it as a thin transparent layer—the **conjunctiva** (Fig. 141, *c*).

A protective flap of skin grows partially over the eyeball from below and another from above. These are the **eyelids**.

The eyeball is connected with the brain by the thick optic nerve (Fig. 141, *o.n*) formed by nerve-fibres which converge from the inner surface of the retina towards a point near its centre to form a solid nerve-trunk which passes straight through the wall of the eyeball and is continued on through the orbit towards the brain.

DEVELOPMENT OF THE EYE.—One of the most fascinating chapters in vertebrate embryology is that dealing with the development of the eye. Any student possessed of an elementary acquaintance with the methods of cutting sections can follow out the main steps in the process for himself on material obtained from hen's eggs which have been incubated from about 1½ days onwards. On this account the description here will deal with the eye of the Bird which, however, agrees in all its main features with that of the Dogfish.

The retina with its stalk the optic nerve is simply a projecting and specialized portion of the wall of the brain. It will be recalled that the brain is the dilated anterior portion of the neural tube, and that its cavity is a portion of the outer world which has been enclosed in the formation of the tube: the inner surface of its wall is part of the original outer surface of the body which has been tucked inwards.

Inspection of a fowl embryo from an egg which has been incubated about a day and a half (see Fig. 192, p. 459) shows that the brain has assumed a **T-shape**—the fore-brain projecting on each side so as to be in contact with the outer skin. The projection mentioned is the **optic rudiment**. The connexion of this with the central part of the brain (thalamencephalon) becomes relatively narrowed and is now known as the **optic stalk**. The outer end of the rudiment becomes gradually tucked into its interior so that the rudiment takes the form of a double-walled **optic cup** (Fig. 142, B and C). The tucking-in process is not confined to the outer end of the rudiment but is continued along its ventral side on to the optic stalk. The cup therefore is not complete but has a gap along its ventral wall—the **choroid fissure**, and the optic stalk is no longer round in section but **∩-shaped**. Of the two layers of the optic cup wall the inner (*r*) gradually thickens and undergoes complicated changes in detail and becomes the functional retina. It is now apparent why the rods in the fully developed retina point away from the lens, for it is this surface of the retina which is next the enclosed portion of the outer world that forms the cavity of the brain: in other

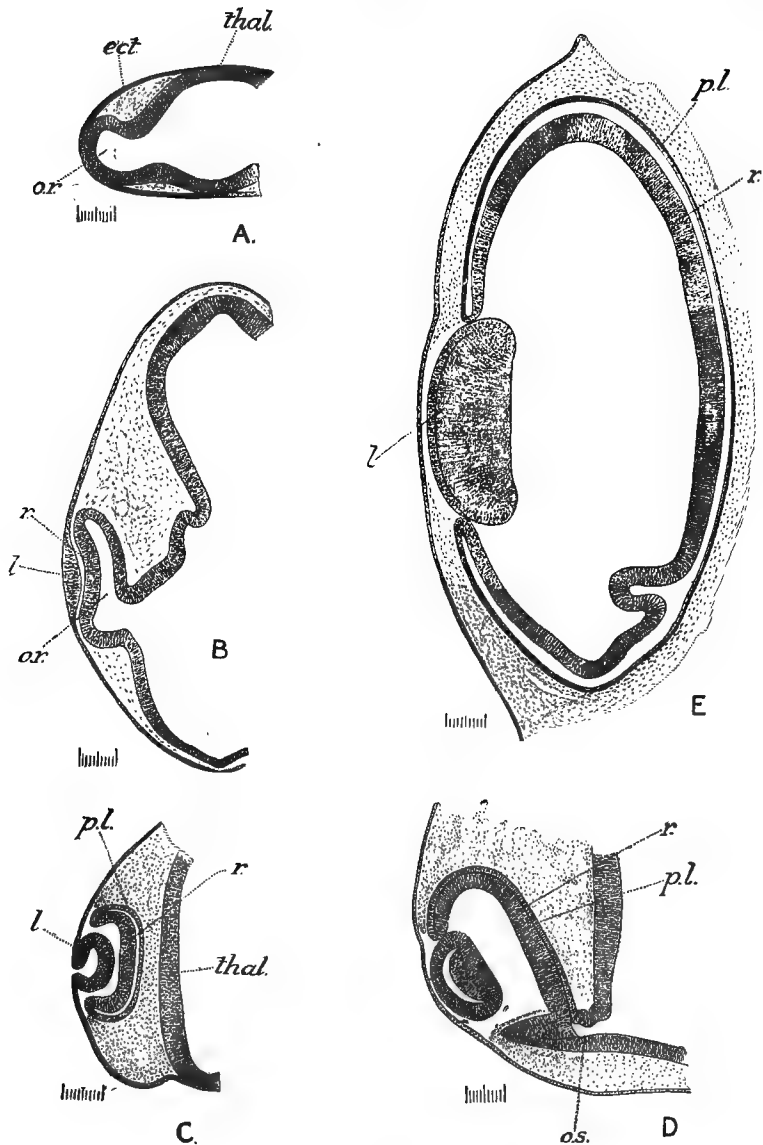

FIG. 142.

Development of the eye as seen in transverse sections of Fowl embryos. A, Latter half of second day of incubation; B, end of second day; C, $2\frac{1}{2}$ days; D, 3 days; E, latter half of fifth day. *ect*, External ectoderm; *l*, lens; *or*, rudiment of eye; *o.s.*, optic stalk; *pl*, pigment layer; *r*, retina; *thal*, wall of thalamencephalon. [The gap below the lens in D is due to the section passing through part of the choroid fissure. Each division of the scales represents $\cdot 0r$ mm.]

words it was originally part of the outer surface of the body, whose normal characteristic it is to be provided with sensory cells pointing outwards. The outer wall of the optic cup becomes the pigment layer (*p.l.*): its cells degenerate and become laden with pigment, and the same applies to *both* layers of the cup in the inturned portion of its rim which lines the iris.

While these developmental processes are taking place the lens has made its appearance. It arises not from the brain-wall but from the external ectoderm. The portion of this in contact with the outer end of the optic rudiment becomes slightly thickened (Fig. 142, B, *l*). As the optic rudiment becomes converted into the optic cup this thickened piece of ectoderm sinks below the surface, lining a cup-shaped cavity the opening of which to the exterior becomes gradually narrower (Fig. 142, C, *l*) until it finally disappears and a closed vesicle is formed, isolated from the external ectoderm. This vesicle is the lens rudiment. With further development it grows rapidly in size and its cavity becomes obliterated by the cells that form its inner wall growing out into a long slender columnar shape. It is these elongated cells, their protoplasm converted into transparent material, that form practically the whole of the lens, the outer wall persisting merely as a thin layer of epithelium coating its outer surface (Fig. 142, D and E).

While the two primary constituents of the eye, Retina and Lens, arise in the way indicated, the outer layers of the eyeball arise simply from the mesenchyme or embryonic connective tissue which becomes concentrated round them. The non-cellular contents of the eyeball—the aqueous humour and the vitreous body—are apparently secreted by the surrounding cells, in the case of the latter probably by the retinal cells.

It will be remembered that in early stages a gap was present in the wall of the optic cup—the choroid fissure. The nerve-fibres which develop on the inner surface of the retina are continued along this surface by way of the gap mentioned on to the involuted portion of the surface of the optic stalk and along it to the brain. As development goes on the choroid fissure becomes a narrow slit and eventually its edges undergo complete fusion. This is how the optic nerve in the adult eye plunges through the retina: it is situated in the position formerly occupied by the bottom of the choroid fissure.

Otocyst.¹—The otocyst of the Dogfish, as of vertebrates in general, arises in much the same fashion as the olfactory organ. A piece of the outer ectoderm on each side of the medulla oblongata becomes thickened and depressed below the general surface, its opening becoming relatively

¹ “Membranous labyrinth” of human anatomy.

constricted so that a sac or vesicle is formed, lying beneath the ectoderm and communicating with the exterior by a narrow tubular channel. This sac is the otocyst. With further development the otocyst undergoes a complicated process of modelling whereby it takes on the form shown in Fig. 143. The most striking feature in this process is that the wall of the dorsal portion of the otocyst comes to project as three prominent plate-like structures arranged in planes perpendicular to one another. These plates become obliterated except along their outer edges, the marginal portion of each persisting as a tube curved in the form of

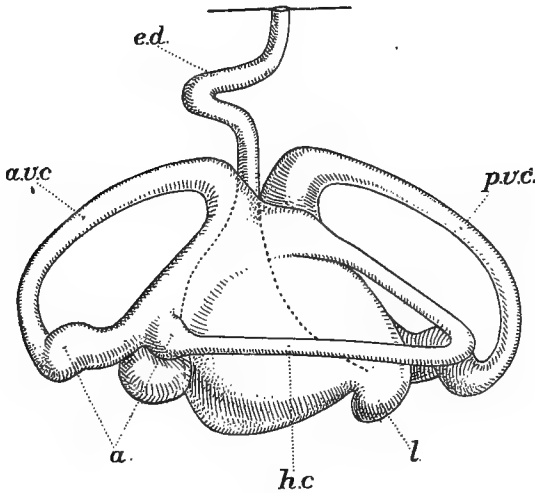

FIG. 143.*

View of the left otocyst of a Dogfish (*Acanthias*) as seen from the left side (after Retzius). *a*, Ampulla; *a.v.c.*, anterior vertical canal; *e.d.*, endolymphatic duct; *h.c.*, horizontal canal; *l*, lagena; *p.v.c.*, posterior vertical canal.

an arch and opening into the main cavity of the otocyst at each end. These are the **semicircular canals** and they are named according to their position—external or horizontal (Fig. 143, *h.c.*), anterior vertical (*a.v.c.*) and posterior vertical (*p.v.c.*). While the planes of the three canals are perpendicular to one another, the plane of the anterior vertical of one side of the body is parallel to that of the posterior vertical on the other side. Each canal becomes dilated at one end to form a rounded swelling—the **ampulla** (Fig. 143, *a*). These remarkable semicircular canals are an arrangement for the more perfect carrying out of the primary function of otocysts—the balancing of the body and the perceiving of changes of position. The existence of three canals in planes at right angles is to

render possible the analysing of a movement of rotation into its components in these planes and its detection whatever its direction may be.

The cavity of the otocyst including the canals is filled with a watery fluid—the **endolymph**. Suppose the Dogfish whose left otocyst is pictured in Fig. 143 as seen from a point away on the animal's left turns sharply to the right, then it is clear that the external semicircular canal will be carried round in its own plane in the direction indicated by the left side of the page. As the endolymph within the canal possesses inertia the lining of the canal will as it were rub over the surface of the stationary fluid. But certain of the lining cells—in the ampulla—possess large sensory hairs which project freely into the endolymph. These as they are dragged through the fluid will be bent and stimulated just exactly in the same way as if they were stationary and the fluid were rushing over them in the opposite direction. In this way a sensation of turning to the right side is produced. It is clear that rolling movements of the body will similarly be detected by the vertical canals and that in fact *any* rotatory movement will give rise to a sensation by the combination of effects on the different canals.

Another point to notice is that prolonged turning movement say to the right will overcome the inertia of the endolymph. This latter will be set in motion and then if the turning movement be suddenly stopped the inertia of the endolymph will keep it moving for some little time and, rushing over the sensory hairs, it will produce a sensation the same as if the body were rapidly turning in the opposite direction. It is in this way that dizziness is produced when a turning movement continued for some time is suddenly stopped.

From the lower corner of the otocyst there projects a bluntly pointed pocket—the **lagena** (Fig. 143, *l*), with sensory cells of a somewhat different type in its lining. This lagena marks the first appearance in evolution of a portion of otocyst devoted to a new sense—that of hearing—and it is destined during the evolution of the higher vertebrates to become an organ of great complexity known as the **cochlea**.

There are two points that should be noted in regard to which the otocyst of the Dogfish and its allies differs from that of the higher vertebrates. In the latter the body of the otocyst becomes deeply constricted across into a dorsal portion the **utricle**, with which the canals are connected, and a ventral portion the **sacculus**, which carries the lagena. In the Dogfish the division of the otocyst into those two parts is less complete, the two cavities still communicating by a long slit-like opening. Further, in vertebrates above the Dogfish group the tubular connection with the outer surface becomes nipped across and the tubular

endolymphatic duct of the Dogfish is replaced by a blindly ending **endolymphatic sac**.

In the lower part of the otocyst are contained large otoliths—masses of small crystals of calcium carbonate lightly bound together by organic material and readily disintegrating into their constituent particles.

As will have been gathered, the otocyst is enclosed within the cartilage of the auditory capsule. The narrow space between otocyst wall and cartilage is occupied by lymph (**perilymph**) and is traversed by occasional fine strands of connective tissue.

LATERAL-LINE SENSE-ORGANS.—Whereas the three pairs of sense-organs described so far are found throughout the whole series of verte-

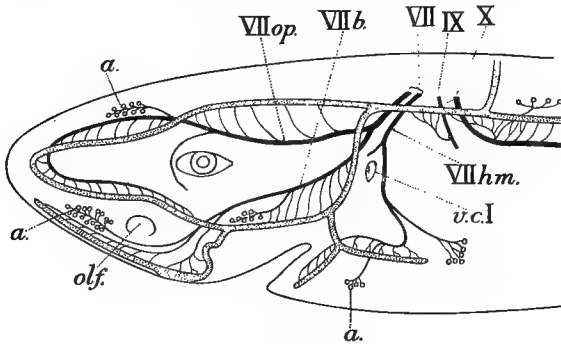

FIG. 144.

Diagram showing the arrangement and nerve supply of the lateral-line sense-organs in a shark (after Ewart). The sensory canals are dotted; the ampullae are shown as small circles; the nerves are shown in black. *a*, Ampullae; *olf.*, olfactory organ; *v.c.I*, spiracle; VII, facial; VII_{op}, superficial ophthalmic branch of facial; VII_b, buccal branch of facial; VII_{hm}, hyomandibular branch of facial; IX, glossopharyngeal; X, vagus.

brates, those now to be described—the sense-organs belonging to the lateral-line system—are peculiar to the lower, water-inhabiting, vertebrates. These sense-organs are small in size, very numerous and are dotted over the surface of the body and head. Each organ consists of a small clump of sensory cells, known as a neuromast, the cells being of the usual columnar shape with a projecting sensory hair at their outer end. Primitively these sense-organs are on the surface of the body but as a rule they become sunk beneath the surface and are found in the adult at the dilated inner ends (**ampullae**) of deep pits, or along the bottom of a groove which may become covered in to form a tube (**sensory canal**) running along parallel to the surface and retaining at intervals a communication with the exterior. The cavity of the tube or pit is kept

open by a clear jelly which is secreted into it by the glandular activity of certain of its lining cells.

The sense-organs may be divided into two sets—(1) those of the sensory canal type which are arranged in rows and (2) those of the ampullary type which occur in clumps.

Of the first type the main row forms the lateral line which stretches back along the side of the body practically to the tip of the tail. The groove containing the sense-organs has become covered in to form a tube with openings to the exterior at intervals. In *Acanthias* the groove remains throughout life as an open groove for some distance from its posterior end. The lateral-line canal is continued in the head region by the system of canals shown in Fig. 144. The arrangement and nerve supply of the various canals will be gathered from the figure. The ampullary type of sense-organ is found in a number of clumps in the head region, each clump including a very much greater number of organs than are shown in the figure. The pits at the bottom of which these organs are situated become so deep as to form long unbranched tubes opening on the surface of the head by conspicuous pores.

As regards the function of these organs of the lateral-line system it must be remembered that it is always impossible to understand exactly the nature of a sense which we do not possess ourselves, but there is some evidence in favour of this sense being akin to that of hearing and of its serving to detect vibrations in the water of a frequency too low to produce a continuous sound.

CHAPTER X

FISHES

ELASMOBRANCHII. Sharks, Dogfish ; Skates, Rays ; (Holocephali).

TELEOSTOMI.

Crossopterygii. *Polypterus*.

Actinopterygii.

Ganoidei. Sturgeons, *Lepidosteus*, *Amia*.

Teleostei. Ordinary Fish.

DIPNOI. Lung-fish.

Appendix.

1. Cephalochorda. *Amphioxus*.

2. Cyclostomata. Lampreys (*Petromyzon*) ; Hagfish (*Myxine*), Borer (*Bdellostoma*).

IN scientific as in everyday language there are grouped together under the name FISHES those lower vertebrates that are specially adapted to a swimming existence. They are linked together by a number of common features. Their paired limbs are in the form of fins and they possess also unpaired fins with skeletal supports. They retain throughout life open gill-clefts and use them for respiration. The spiracle does not become modified in relation with the sense of hearing as is the case with terrestrial vertebrates. The main muscles of the body retain their primitive segmentation into myotomes throughout life.

A few different genera of fish show the remarkable structures known as **electric organs**. These are, with one possible exception, composed of modified muscles. Muscle in general may be said to be living substance, specialized for the function of contraction. When it actually functions the obvious thing that happens is the change of form—shortening and thickening—of the muscle, but accompanying this is a much less conspicuous subsidiary phenomenon namely the production of a slight electric disturbance. Now in electric organs the primitively predominant

function of contraction has been reduced while the primitively subsidiary rôle of producing electric disturbance has become predominant.

The typical fishes fall naturally into three sharply defined main groups — Elasmobranchii, including Sharks and Rays, Teleostomi, including the vast majority of fish, and Dipnoi or Lung-fish.

Of the ELASMOBRANCHII the structure of a typical example has been described in detail in Chapter IX. The main features which together serve to mark off the Elasmobranchs from other fishes are: (1) the placoid scales, (2) the restriction of bony tissue to the scales—the main skeleton being entirely cartilaginous, (3) the separate gill-openings, (4) the absence of a lung or air-bladder, (5) the persistent external opening of the otocyst, (6) the large richly-yolked eggs. With these are associated two important features common to other archaic types of fish, namely the presence of a spiral valve in the intestine, and the presence of a rhythmically contractile conus arteriosus provided with pocket-valves.

Apart from interesting extinct types the group includes the modern sharks and dogfish. The largest of all fish are the Basking-sharks or Sail-fish (*Selache maxima*) which reach a length of 35-40 feet and, like the whales among mammals, feed on small pelagic animals. These fish are provided with greatly elongated horny gill-rakers set close together like the teeth of a comb and forming an efficient mechanism for straining off food-organisms from the water as it rushes out through the gill-clefts. In correlation with this peculiar method of feeding the teeth are much reduced in size. Almost equally large is the ferocious *Carcharodon*, which reaches a length of over thirty feet. In this case the teeth are broad flat triangular blades with finely serrated edges. Judging from the size of occasional teeth dredged up from the bottom of the Pacific and others from recent geological deposits it would appear that sharks of this genus have attained in the past a length of as much as ninety feet.

Besides the typical sharks (Selachii) the group includes the skates and rays (Batoidei) modified in accordance with their habit of swimming along the sea-bottom. In them the body is much flattened from above downwards, the tail region is comparatively degenerate, while on the other hand the pectoral fins are enormously enlarged, forming the greater part of the whole body. The ordinary gill-clefts open on the lower surface of the body but the spiracle, which serves for the indraught of the water of respiration, is situated on the dorsal surface so that mud is not drawn in with the respiratory current.

In the skates a spindle-shaped mass of muscle on each side of the

tail-region has been converted into a feeble electric organ. In the Electric Ray on the other hand—to which the Romans gave the name *Torpedo*, still used as the generic name—much larger masses of muscle, connected with the branchial arches, have become converted into an electric organ capable of giving powerful shocks.

Usually included within the limits of the Elasmobranchii are a number of strange, mostly deep-sea, fish grouped together under the name Holocephali—the last survivors of an ancient group of fishes dating from Palaeozoic times. They are comparatively rare fish except one species, belonging to the genus *Chimaera*, which is common off the west coast of North America.

The Holocephali agree in their general structure with the other Elasmobranchs but they show decided peculiarities of their own. The notochord persists throughout life and there are no vertebral centra developed. The tail is protocercal. The upper jaw undergoes complete fusion throughout its length with the cranium so that the lower jaw articulates directly with the cranium (**autostylic** skull). And, as in the more highly evolved fishes about to be described (Teleostei), the spiracle is obliterated, the outer ends of the gill-clefts have become confluent into a single (opercular) opening, and the cloaca has become flattened out so that the nephridial and genital ducts open on the external surface independently of the intestine.

Of the Teleostomatous fishes it will be convenient to consider first the TELEOSTEI, the group which includes the great majority of existing fishes and nearly all of those familiar in ordinary life. Among all vertebrates the teleostean fishes stand out pre-eminent in their adaptation to, and specialization for, a swimming existence.

The general form of the body may depart from the ordinary "fish" shape (Fig. 145) by being "depressed," i.e. flattened in a dorso-ventral direction as is the case with the Skates amongst Elasmobranchs, or it may be "compressed," flattened from side to side, as in a Bream or as—to an extreme extent—in the flat-fishes or Pleuronectidae, or it may be much drawn out in length as in the Eel.

There is an equipment of fins, similar in general arrangement to that of Elasmobranchs. The caudal fin, while fundamentally similar to that of the elasmobranch, has developed a superficial difference by assuming a secondarily symmetrical (**homocercal**) form (Fig. 146, E and F). That this symmetry is merely superficial is shown by the internal structure—the tip of the vertebral column not being continued out through the central line of the tail but being distinctly tilted upwards. In cases where the tail loses its importance as a propelling organ it is apt to

revert to the primitive pointed (**protocercal**) condition (Fig. 146, A) which occurs normally in fishes during early stages of development and is found persisting in the adult in some of the more archaic groups of fish to be dealt with later.

A point to be noted specially is that the fins of fish—apart from the caudal fin—are by no means fixed permanently in position but in the course of evolution tend to undergo slow shifting so as in any particular phase of evolution to be in the position in which they can be used to best advantage, having regard to the habits and general form of the body. An extreme illustration of this mobility of the fins during evolution is afforded by the pelvic fin of such a fish as the Cod or

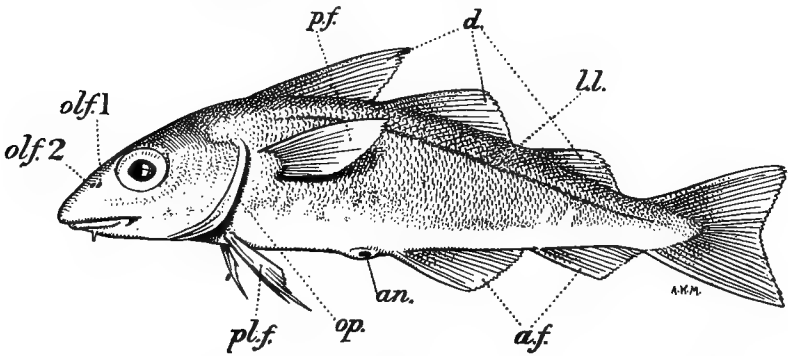

FIG. 145.

A Teleostean Fish—Haddock (*Gadus aeglefinus*). *a.f.*, Anal fins; *an.*, anus; *d.*, dorsal fins; *ll.*, lateral line; *olf.1* and *2*, olfactory openings; *op.*, opercular opening; *p.f.*, pectoral fin; *pl.f.*, pelvic fin.

Haddock which has become shifted so far forwards as to be “jugular” in position—well in front of the pectoral fins (Fig. 145, *pl.f.*).

The skin of the Teleost is specialized for the diminution of “skin-friction”—the friction between its surface and the surrounding medium which constitutes the main obstacle to the passage of a solid body through water. To minimize this the epidermis has scattered through it innumerable gland-cells which secrete an exceedingly slippery mucus and thus lubricate the surface of the body.

Beneath the epidermis there are normally present scales of a more highly evolved type than the placoid scales of the Elasmobranch. These **cycloid** scales (Fig. 147) are very thin plates of peculiarly tough bone, which overlap like slates on a roof and are consequently able to slide over one another so as not to interfere with the flexibility of the body. The growth of the fish is accompanied by increase in size of the individual

scales—by the addition of new bone especially round their edges—the total number of the scales remaining constant.

In the case of teleostean fishes inhabiting regions with well-marked differences between the seasons there is frequently evidence of the growth of fresh bone being affected by these differences. During the winter, when metabolism is less active, growth is slower and the calcareous matrix of the bone formed is more dense; during summer growth is more rapid and the bony material is less dense. This periodicity affects the scales as well as the bones in general. In many cases the surface of the scale projects in the form of fine concentric ridges (Fig. 147, B) or other pattern, and in the portions of the scale formed during the summer these ridges are more widely spaced out (*S*) while in those formed during the winter they are more closely crowded together (*W*). As a consequence such scales when examined under the microscope are seen to bear a record of their age, somewhat analogous to that afforded by the annual rings of a tree-trunk, and these scale records are made practical use of in fishery investigations, more especially in the case of fresh-water fish of cold temperate climates such as the Salmon. The record conveys other information than the mere age. Where the act of spawning brings about a great diminution in the bulk of the body this is apt to cause the edges of the scales to project and become frayed and worn, and on the return to normal conditions when the growth of the scale is again active the new lines of growth follow the worn and irregular outline which remains registered in the scale as a more or less distinct “spawning mark” (Fig. 147, B, *s.m.*).

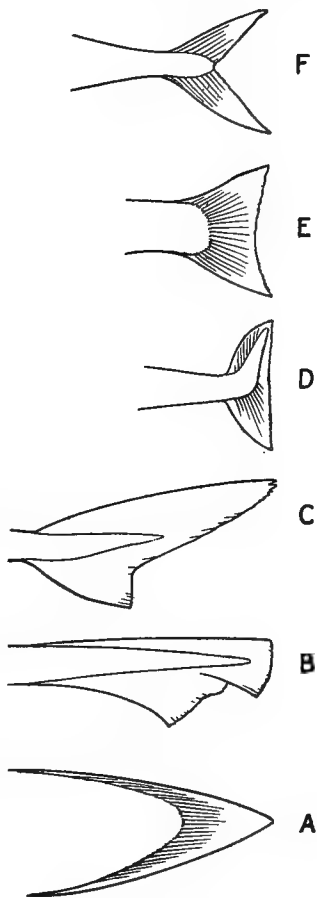

FIG. 146.

The tails of fishes. A, *Ceratodus* (Dipnoi); B, *Scyllium*, and C, *Acanthias* (Elasmobranchii); D, *Cladoseleache* (fossil Elasmobranch); E, Trout, and F, Mackerel (Teleostei).

The scales differ much in size in different teleosts. In particular cases they become greatly reduced in size (Eel) or even completely disappear (many Siluroids, see p. 363). In other cases the bone formation in the skin becomes continuous over large areas, forming great plates of bone articulated together to form a rigid coat of mail as in many of the tropical Siluroids or Cat-fish.

Of much greater importance however is the fact that in the teleostean fishes the formation of bone is no longer restricted to the skin. The

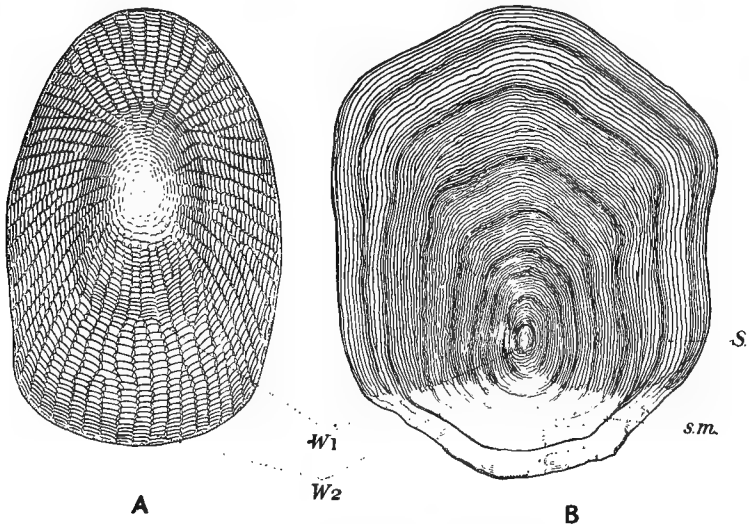

FIG. 147.

Zones of growth in scales of Teleosts. A, Haddock at commencement of its third summer (after Stuart Thomson). B, Salmon of ninth summer. S, Widely spaced lines of growth indicating active metabolism on return to sea after spawning; s.m., spawning mark; W₁, growth lines of first winter; W₂, growth lines of second winter.

capacity of forming bone has spread down into the substance of the body, infecting especially the layer of connective tissue adjacent to the surfaces of the cartilaginous skeleton. The result is that the cartilage becomes ensheathed and strengthened by a layer of the harder and more rigid bone, in the form of numerous more or less flattened **investment bones** or "membrane bones" applied close to the surface of the underlying cartilage. The process does not stop here for the bone-forming connective tissue tends to eat its way into and actually replace the underlying cartilage, giving rise to **replacement bones** or "cartilage bones."

In a typical teleostean fish then the cartilaginous skeleton, constructed on the same plan as that of the Elasmobranch, becomes ensheathed and to a great extent replaced by bone. The extent to which actual replacement takes place differs in different teleosts. Different steps in the process are well seen in comparing the skull of a Salmon with that of a Cod. In the Salmon the skull appears in external view to be composed of a complicated array of bones, named for the most part after bones that occupy roughly corresponding positions in Man and other terrestrial vertebrates, but if these bones are removed there is found underlying them a massive and well-developed cartilaginous cranium, only small portions of which are replaced by bone. In the Cod on the other hand while a similar array of investment bones are seen on the surface of the skull, the cartilaginous cranium is found also to be replaced so completely by bone that one would naturally describe the Cod's skull as being entirely bony although as a matter of fact small portions remain still cartilaginous. On the whole we may say that the predominant characteristic of the adult teleostean skeleton as compared with that of the Elasmobranch is that while constructed on the whole of corresponding parts arranged on the same plan it is composed of bone instead of cartilage.

A conspicuous difference between the Teleost and the typical Elasmobranch is seen in the external opening of the gills, there being here in place of the series of separate openings a single large **opercular opening** on each side, bounded in front by a large gill-cover or operculum (Fig. 145, *op*). The meaning of this difference is rendered apparent by making a horizontal cut backwards from the angle of the mouth. It is then seen (Fig. 148) that there are actually five separate gill-clefts opening outwards from the pharynx but that the outer portions of these clefts have been thrown into one by the disappearance of the greater part of the gill septum, the thickened pharyngeal edge of which alone persists. A result of this is that the respiratory lamellae, instead of being attached to the gill septum along almost their whole length, are attached only at their inner ends, their outer portions hanging freely (Fig. 148, B, *r.l.*, and Fig. 149). While this change has come over the gill septa belonging to the branchial arches, it does not take place in the case of the hyoid arch. On the contrary the valvular flap formed by its outer portion, which in the Elasmobranch covered over only the first branchial cleft (Fig. 124, p. 299), is now greatly enlarged, covering in the whole series of clefts behind the hyoid arch. This enlarged hyoidean valvular flap is known as the **operculum** (Fig. 148, A, *op*).

The Spiracle or first cleft, though it appears as a rudiment in the

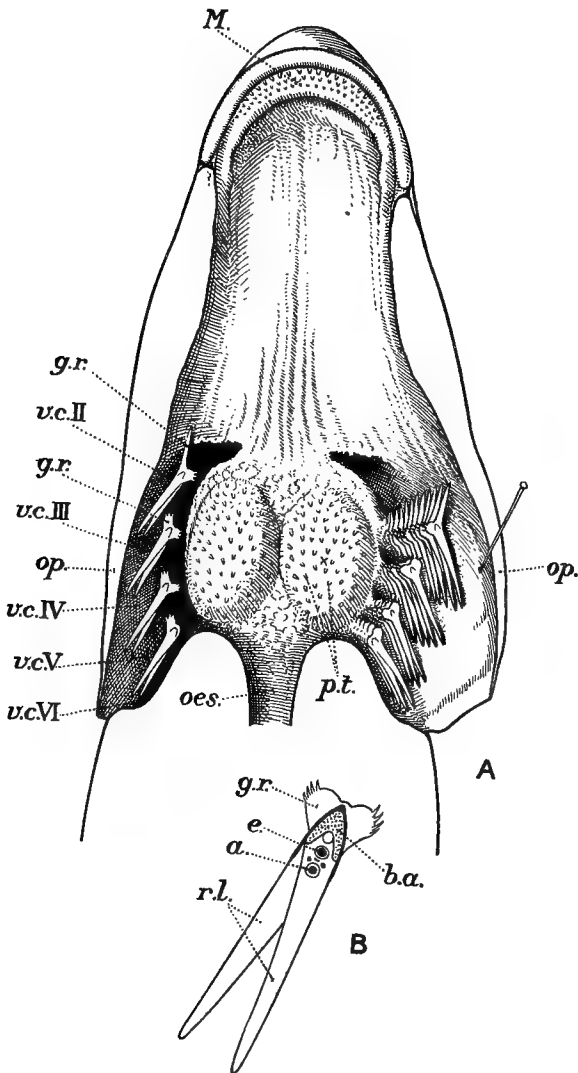

FIG. 148.

A, Horizontal section through gill-clefts of Haddock; B, a single branchial arch from A shown on a larger scale. *a*, Afferent vessel; *b.a.*, branchial arch; *e*, efferent vessel; *g.r.*, gill-rakers; *M*, mouth opening with teeth; *oes*, oesophagus; *op*, operculum (that of the left side has been pulled outwards to display the gills more clearly); *p.t.*, pharyngeal teeth; *r.l.*, respiratory lamellae; *v.c.* II-VI, visceral clefts.

embryo, never becomes functional or even perforate so far as is known in Teleosts.

The breathing of the fish is carried out by characteristic movements which ensure the respiratory lamellae being bathed by a fresh stream of water. The pharynx is dilated by the action of muscles attached to the skeleton of the branchial arches and water is thus drawn in through the widely open mouth, the operculum at the same time being sucked in against the body-wall so as to prevent any indraught through the opercular opening. After the pharynx is filled in this way the branchial musculature brings about a contraction which tends to force the water out again. The mouth is closed, the closure being completed by valvular flaps within the lips. Thus no water passes forwards through the mouth opening. It all passes backwards, the operculum opening so as to allow a free exit. The rhythmic repetition of these respiratory movements causes a continual pumping of water in at the mouth, over the surface of the lamellae and out by the opercular opening.

In connexion with the respiratory region of the alimentary canal there exists in the typical Teleost a characteristic organ known as the **air-bladder** or swim-

bladder. This arises during development as a pocket-like outgrowth of the wall of the alimentary canal, as a rule near the mid-dorsal line though sometimes well to one side or the other. The outgrowth reaches a large size, extending tailwards immediately dorsal to, but outside, the splanchnocoel (see Fig. 154, D, p. 367). Commonly an outgrowth of the air-bladder wall bulges forwards towards the head, so that the original connexion with the alimentary canal, now narrow and tubular (**pneumatic duct**), is attached not to the headward end of the

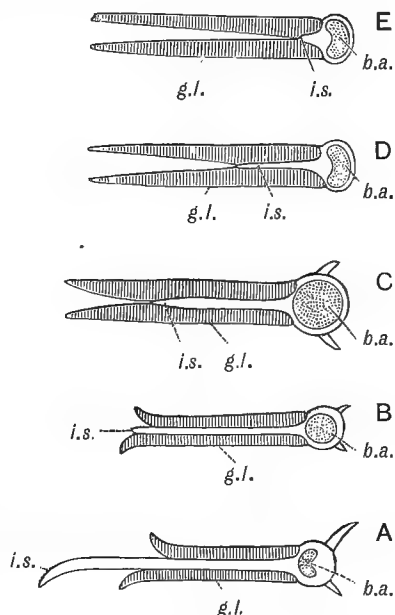

FIG. 149.

Illustrating the relations of the respiratory lamellae and gill-septa in an Elasmobranch (A), a modified Elasmobranch—*Chimaera* (B), a Sturgeon—*Acipenser* (C), and two different Teleosts (D and E). (From Boas, *The Cambridge Natural History*, vol. vii.). *b.a.*, Skeleton of branchial arch; *g.l.*, respiratory lamellae; *i.s.*, gill-septum.

air-bladder but to its ventral side. Varied modifications of the form of the air-bladder occur. It may be constricted into two or three portions lying one behind the other: it may give rise to more or less tubular outgrowths. In some cases a tubular outgrowth on each side in front extends to the neighbourhood of the otocyst, its wall forming a portion of the otherwise rigid boundary of the cavity enclosing the otocyst with its perilymph. In many Teleosts the air-bladder retains throughout life its communication with the alimentary canal (**physostomatous** condition—Fig. 154, p. 367, D) but more usually this communication becomes obliterated and the air-bladder forms a completely closed cavity (**physoclistic** condition—Fig. 154, E). Apparently this closure has come about in the course of evolution independently in several different cases so it is no longer customary to regard fishes in which it has happened as forming a natural group by themselves (“Physoclisti”).

Functionally the air-bladder is of great interest. In some few physostomatous Teleosts the lining of the organ is provided with a rich network of blood-vessels,¹ air is swallowed into the air-bladder, and it fulfils an important respiratory function. As will emerge later there is reason to believe that here we have to do with a persistence of, or a reversion to, the primitive function of the organ. Where there is a close relation with the otocyst the air-bladder probably aids in the detection of vibrations in the water. A wave of compression reaching the fish, and causing a slight inward displacement of the wall of the air-bladder over a great part of its surface, will tend to give an increased displacement to the much smaller portion of wall in contact with the perilymph and sheltered from the external pressure.

The main function of the air-bladder in a typical teleost is neither respiratory nor auditory: it is to act as a float. It used to be thought that it helped the fish to sink or rise in the water: by muscular contraction of the body-wall the gaseous contents of the air-bladder were compressed, the specific gravity of the animal's body was increased and it sank. On the other hand relaxing the musculature of the body-wall allowed the gas to expand, the specific gravity was diminished and the fish floated upwards. Modern investigation has shown that the mode in which the air-bladder carries out its hydrostatic function is much more complicated than it would be on this simple theory. In the first place the air-bladder is an organ not for altering the specific gravity of the fish but for keeping it constantly the same as that of the water in which it is swimming, counteracting the changes that would otherwise be

¹ The air-bladder of teleosts receives its blood from various branches of the dorsal aorta.

produced in its specific gravity by changes of level and consequent changes in pressure. It is obvious that if a fish swims downwards it becomes subjected to greater and greater pressure due to the superincumbent water; the gas in its air-bladder will be more and more compressed by this pressure, and the specific gravity of the fish will increase. If it started by being of exactly the same specific gravity as the water, it will become relatively heavier and heavier as it swims downwards and will consequently tend to sink. Conversely if it swims upwards the gas in its air-bladder under the diminishing pressure will expand more and more, and it will tend to be carried helplessly up to the surface. It is the function of the air-bladder to counteract these inconveniences and dangers by keeping the body of the fish precisely at the specific gravity of the surrounding water, so that it floats at one level without requiring to expend muscular energy in combating a tendency either to float upwards or to sink downwards. This is achieved not by muscular action but by alteration of the actual quantity of gas in the air-bladder. The compression due to increased pressure is met by increasing the amount of gas; the expansion due to diminished pressure is met by reducing the amount of gas. The first-mentioned process, the increase in the amount of gas, is clearly brought about by the activity of the wall of the air-bladder, for it takes place in physostomatous fishes which are prevented from taking in air at the surface, and in physoclistic fishes where the air-bladder has no longer any opening. It might be, and actually was at one time, supposed that the additional gas is provided by a simple process of diffusion from the blood circulating in the wall of the organ. That this is not the case, however, became apparent when analyses were made of the gas in the air-bladder. This is found to consist of the ordinary gases of the atmosphere but by no means in their ordinary proportion. In fishes from considerable depths in the sea there is usually a very high proportion of oxygen—ranging it may be up to more than 90 per cent. Now the ordinary processes of diffusion could not bring about a concentration of oxygen higher than that in the blood itself. In fact were gas containing this high percentage of oxygen in a cavity of the body subject to the ordinary laws of diffusion, the tendency would be rather for it to diffuse away until the oxygen pressure was no greater than that of the oxygen in the blood and other fluids of the body. The process at work then must be no mere physical process of diffusion but something definitely vital which can force gas into the cavity of the swim-bladder in spite of a high pressure of the same gas already within the cavity. As a matter of fact the process seems to be entirely analogous to the process of secretion in a gland: the air-bladder is in a sense a

large gas-gland. The actual process of secretion is carried out not by the entire lining of the organ but by patches of special glandular epithelium known as **red bodies** or **red glands** from their highly vascular character. These reach their highest development in the physoclistic fishes. In these the columnar glandular epithelium of the red gland, the cells of which secrete bubbles of gas like the gas vacuoles of Protozoa, dips down into deep crypts between which pass up loops of blood-vessel. These show a very remarkable arrangement, both the afferent and the efferent vessel of each loop being broken up for a considerable distance into a number of fine parallel channels. Such subdivision of blood-vessels into a number of channels appears to be a safeguard against occlusion of the vessel through great pressure. Well-known examples of the same phenomena are seen in the blood-vessels of Whales which break up to form what were called by the older anatomists *retia mirabilia*. It is obvious that the wall of the air-bladder in a fish will be subjected to great pressure if it swims for some distance upwards before the expansion of the contents of the air-bladder is corrected. The gas-glands of the fish are under the control of the nervous system and one of the first striking bits of evidence indicating that their mode of action is analogous to that of ordinary glands is the fact that interference with their nerve supply produces exactly the same results as it does in the case of such typical glands as those of the stomach in one of the higher vertebrates—severing the branches of the vagus which supply them bringing about a cessation of their activity.

Diminution in the amount of gas is brought about by a process of absorption ; and in the more highly developed air-bladders the absorptive power is concentrated in a special portion of the lining of the air-bladder termed the **oval**. This is a highly vascular area covered by epithelium which appears to have the power of absorbing gas from the cavity of the air-bladder and of passing it away in solution into the blood. The regulation of its effect is brought about by a muscular arrangement resembling the iris-diaphragm of a microscope which more or less completely closes over it so as to separate its surface from the gaseous contents of the organ.

It remains to inquire how the mechanism of the air-bladder is awakened into activity. The lining of the organ contains numerous sensory-cells and it is probably messages from these to the central nervous system which arouse a reflex activity, either secretive or absorptive as may be required.

As regards the region of the alimentary canal behind the pharynx

there are one or two peculiar features to be noted. The spiral valve has disappeared from the intestine, although slight vestiges of it persist in a few cases. In correlation with this a secondary lengthening of the intestine has taken place so that it takes a tortuous course through the splanchnocoel in striking contrast with the condition in an Elasmobranch. In the region of the pylorus a varying number of glandular more or less finger-shaped outgrowths of the wall of the alimentary canal are found—the **pyloric caeca**. Finally there is a well-marked tendency for the cloaca—the terminal part of the alimentary canal into which open the renal and genital ducts—to become flattened out so that anus, genital and renal openings come to be situated on the external surface one behind the other.

The renal organ of the teleost is an opisthonephros. The right and left organs with their ducts are at first separate but as development goes on fusion takes place which may affect only the hinder portion of the ducts or may spread to the hinder portion of the renal organs themselves.

The reproductive organs show a peculiarity highly characteristic of the group—namely that the wall of the gonad is continued backwards as a simple tubular prolongation which functions as its duct and opens to the exterior by an opening common to the two ducts between the anal and renal openings. The probable evolutionary origin of these genital ducts of the Teleostei forms an interesting problem in morphology. The general relations of the ducts are very similar in the two sexes but the probability seems to be that this likeness is secondary and that the ducts of the male and female have arisen in evolution in quite different ways.

In the elasmobranch the eggs are of large size and as a consequence relatively few in number. In the typical teleost on the other hand the eggs have become greatly reduced in size and greatly increased in number. At the same time they are without the elaborate envelopes secreted by the oviducal wall that are present in the elasmobranch. Apparently in correlation with the fact that a long glandular oviduct is no longer needed for the formation of such envelopes the Müllerian duct of the teleost has become much reduced in length. The ovary has developed the peculiarity that the eggs set free from its surface fall not into the main splanchnocoel but into an enclosed space formed either by the lower edge of the ovary becoming fused to the body-wall (Fig. 150, B) or by an ingrowth of the surface of the ovary becoming covered in by its edges meeting (Fig. 150, A). In either case the cavity

so formed becomes continuous with the wall of the oviduct so that in the teleost the eggs never pass into the peritoneal cavity at all.

As regards the evolutionary origin of the male duct we obtain, as will be seen later (p. 378), interesting hints from some of the more ancient types of fish.

The blood-system of the teleost is arranged on the same general plan as that of the elasmobranch, the only difference that need be mentioned being that the two posterior cardinal veins tend to become approximated together and to undergo fusion to form a single **interrenal** vein which passes forwards between the two kidneys. An important and striking difference in detail is seen in the structure of the heart. In the elasmobranch the portion of the primitive heart or cardiac tube lying between the ventricle and the anterior boundary of the pericardiac cavity constitutes the rhythmically contractile *conus arteriosus*. In a few

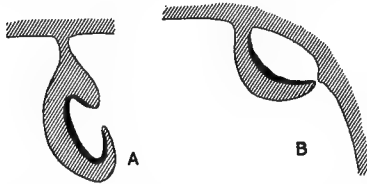

FIG. 150.

Diagrammatic transverse sections illustrating the developing ovary of Teleostean fishes. A, Perch, Stickleback; B, Carp.

aberrant teleosts such as the Tarpon (*Megalops*) the muscular, rhythmically contractile, character has become restricted to a comparatively short portion next the ventricle which, however, still contains two valves to represent each of the original three longitudinal rows of pocket-valves. In the typical teleost the rhythmically contractile part of the conus has disappeared entirely and the original three longitudinal rows of pocket-valves are each reduced to a single valve, the three forming a circle round the ventricular exit. The whole of the cardiac tube lying between this and the anterior limit of the pericardiac cavity has lost those features which entitled it to be regarded as physiologically a chamber of the heart—the presence of a thick layer of striped muscle fibres in its wall, and the fact that it is rhythmically contractile. It has on the other hand approximated in character to the ventral aorta, its wall being composed for the most part of tough connective tissue containing numerous elastic fibres. In the majority of teleosts this anterior non-contractile portion of the cardiac tube is considerably thickened forming what is called the **aortic bulb**¹—differing from the typical muscular conus in its whitish colour.

¹ Students of human anatomy should take care not to be confused by the term *bulbus cordis* which is applied in human anatomy to what comparative anatomists call the *conus arteriosus*.

As regards the nervous system, the brain (Fig. 151) shows two striking differences from that of the elasmobranch. There is a large well-developed cerebellum (*c*) which projects back as a somewhat tongue-shaped organ over the roof of the fourth ventricle. If, however, the brain is cut through with a sharp knife in the sagittal plane it is seen that a forward continuation of the cerebellum dips inwards underneath the optic lobes, encroaching upon the cavity of the mid-brain. This is known as the **valvula cerebelli**. Whereas in the elasmobranch the cerebellum as it grows in length bulges outwards, in the teleost on the other hand only its posterior or tailward portion bulges outwards, its anterior portion bulging inwards into the ventricular cavity so as to form the valvula cerebelli.

There is reason to suspect that a somewhat similar though more extensive modification has taken place in the region of the hemispheres. The portion of brain-wall which in the typical vertebrate bulges out to form the hemisphere appears to be represented in the teleost by a solid thickening which projects into the cavity of the anterior portion of the brain from its floor (Fig. 151, *c.s.*) and is covered over by a thin membranous roof (*pr.*).

The last feature which need be mentioned is that the optic lobes are of relatively enormous size in most teleosts (Fig. 151, *op.l.*)—in correlation with the very high development of the eyes.

The Teleost possesses the same outfit of sense organs as the Elasmobranch. The eyes, apart from their large size, show an interesting peculiarity in regard to their focusing arrangements. A projection from the choroid known as the **falciform process** penetrates the vitreous body in the neighbourhood of the optic nerve and passes in a meridional direction towards the lens, to the equator of which it is attached by a curious bulb (the "campanula Halleri"). The falciform process is provided with longitudinal muscle fibres which by their contraction pull the lens nearer the retina so as to focus more distant objects—the eye when in a state of rest being focused for objects close at hand. Here we have

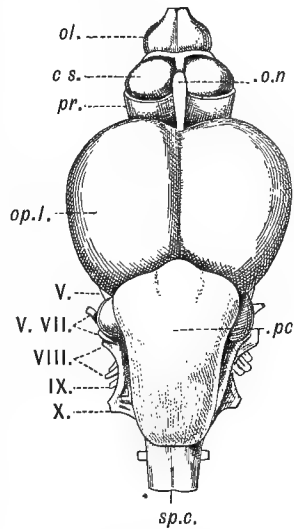

FIG. 151.

The brain of a teleost (Salmon). (From Wiedersheim, *The Cambridge Natural History*, vol. vii.) *c*, Cerebellum; *c.s.*, solid mass projecting into cavity of fore-brain; *ol.*, olfactory lobe; *op.l.*, optic lobe; *pn.o.*, pineal organ; *pr.*, thin roof of fore-brain, partially removed; *sp.c.*, spinal cord. Roman figures indicate cranial nerves.

two striking differences between the eye of the teleost and that of a Mammal such as Man in which (1) the eye when at rest is focused on distant objects and (2) **accommodation** (change of focus) is brought about not by displacement of the lens but by a change in its curvature.

The olfactory organ of the Teleost has become shifted on to the dorsal surface of the snout and its external opening is usually divided by a cross bridge into two. For comparison of these two openings with those in the higher vertebrates (see p. 389) it must be borne in mind that the shifting on to the dorsal surface causes a reversal in the position of the openings, that which is anterior in the original position coming to be in the teleost posterior.

The otocyst has lost its communication with the exterior. The large otolith in the saccule is usually very hard and dense and in many cases shows distinct zones of growth like those of the scales so that it may be used for age-determination.

The group Teleostei includes as already mentioned the great majority of modern fishes: they constitute one of the predominant groups of vertebrates existing at the present day and they represent the highest evolutionary attainment in the way of specialization for an aquatic existence. The group is subdivided into a large number of families of which a few of the more important must be mentioned.

The Mormyridae are a group of African fresh-water fishes noteworthy in two respects: (1) the brain is of greater proportional size than in any other lower vertebrates and (2) the group includes two genera (*Mormyrus* and *Gymnarchus*) possessing small electric organs in the tail region.

The Clupeidae include a number of important food-fish such as the Herring, Sprat, Pilchard, Anchovy and Shad. "Sardines" are young Pilchards, and "Whitebait" consists mainly of the fry of Herrings. A point of much economic importance is that the eggs of the Herring instead of floating freely in the water, as is the case with most marine food-fish, are "demersal," i.e. they lie on the bottom, adhering to one another and to stones—so that they are liable to destruction by heavy trawls scraping over the bottom of the sea.

The Salmonidae include the various kinds of Salmon, Trout, Charr, Whitefish, Grayling and Smelt. Many of them have taken to fresh water either as permanent residents or as temporary visitors for the purpose of spawning (Salmon, "Sea-trout"). The name **anadromous** is applied to fish which ascend rivers in order to spawn.

The Characinidae include a great variety of fresh-water fish of the African and South American continents. Amongst them are the Salmon-

like "Dorado" of the Río de la Plata and the ferocious Serrasalmo ("Piranha," "Palometa") of South American rivers.

The Gymnotidae include the most powerful of the electric fishes—the Electric Eel (*Gymnotus*) of tropical swamps in the basins of the Amazon and Orinoco. A mule touching one of these fish as it wades through a swamp may be brought down instantaneously by the shock.

The majority of the fresh-water fishes of the Northern Hemisphere belong to the family Cyprinidae—for example the Carp, Dace, Chub, Roach, Minnow, Bream, Loach. Many are vegetarian feeders and as a rule they are not of much value as food for man.

The family Siluridae corresponds roughly with what are popularly called "Cat-Fish," perhaps from the sensory tentacle-like "barbels" in the neighbourhood of the mouth. There are no cycloid scales, bony tissue being either absent in the skin of the general surface of the body or, at the other extreme, forming large bony plates which articulate together so as to form a rigid armour coat.

Included in the group is the powerful electric fish *Malopterurus* of tropical Africa and Egypt, in which the electric organ is unique in being a development of the skin. It is innervated by a special nerve on each side of the body, consisting of a single gigantic nerve-fibre enclosed in a thick insulating sheath (medullary sheath), dividing into an immense number of branches, and originating in a large ganglion-cell situated in the spinal cord near its front end.

The Siluroids inhabit for the most part fresh water and the group is widely spread over the surface of the earth.

The Anguillidae have long snake-like bodies. The scales are much reduced in size (Common Eel—*Anguilla*) or entirely absent (Conger-eel—*Conger*). The pelvic fins have disappeared.

Until comparatively modern times the life-history of the eel formed an unsolved puzzle, fully ripe specimens of the common eel being unknown. It is now known that the eel is **catadromous**, i.e. it descends the rivers into the sea to spawn. As sexual maturity approaches the eels wander down the rivers and having reached the sea continue their migration, in the case of European eels, westward towards the spawning grounds which are situated in the West Atlantic, south of Bermuda. The eggs develop into pelagic larvae differing greatly from the parent eel in appearance, the body being greatly flattened from side to side and much deepened in a dorso-ventral direction. They are of a glassy transparency and colourless, the blood even being devoid of haemoglobin. Such larvae were formerly classified together as a genus by themselves and given the name *Leptocephalus*. The *Leptocephalus* larvae drift

eastward with the ocean currents and on nearing the coasts of the old world they metamorphose into young eels or "elvers." These work their way along the coasts and crowd up into fresh waters, there to spend their lives until the approach of sexual maturity.

The Gadidae include a number of the most important marine food-fishes such as the Cod, Haddock, Whiting, Pollack or Lythe, Coal-fish or Saithe—all species of *Gadus*; the Hake (*Merluccius*) and Ling (*Molva*). The Burbot (*Lota*) is a fresh-water representative of the family.

The Percidae (Perch), the Mullidae (Red Mullet), the Labridae (Wrasse), the Scombridae (Mackerel, Tunny), the Xiphiidae (Sword-Fish), the Zeidae (John Dory) all include well-known fish.

The Pleuronectidae or Flat-fishes include a number of important food-fish such as the Halibut, Plaice, Flounder, Dab, Lemon Sole, Turbot and Sole. They are of special morphological interest from the asymmetry which they develop during their growth. In the young stage they are symmetrically shaped and swim in the normal position, dorsal side above. The body becomes gradually more and more compressed from side to side and the young fish take to swimming on one side along the bottom. In some species it is the right side which is underneath, in others the left, in still others either side indifferently. In the head region growth takes place with greater activity on the lower side and this causes much distortion, the eye of the lower side becoming gradually displaced upwards so that both eyes come to be situated on the same side of the body. Chromatophores or pigment-cells make their appearance and these crowd together near the upper surface of the body giving it a colouring resembling that of the background, while the under side, without pigment-cells, is pure white. That the definitive position of the chromatophores is a reaction to light has been demonstrated by rearing young flat-fish in an aquarium with an opaque lid and lighted through its glass bottom: this resulted in fish which were reversed as regards their coloration, the under side being pigmented, the upper white.

The small family Trachinidae should be mentioned as it contains the Weevers of the European coasts—well known for the poisonous wounds inflicted by their sharp dorsal and opercular spines. The poison is secreted by special glands at the base of the spines.

Along with the highly evolved modern teleostomes there still exist at the present day remnants of earlier stages in their evolution in the form of a few odd genera which have lagged behind in evolutionary progress. Of these there are first to be mentioned the *CROSSOPTERYGII*, which during the ancient times of the Old Red Sandstone and the Coal period

were one of the predominant groups of fishes but are now on the verge of extinction, being represented by only a couple of genera—*Polypterus*, found in the great river-basins of Africa which drain into the Atlantic and Mediterranean, and *Calamichthys* which is restricted to the rivers of tropical West Africa.

Polypterus (Fig. 152) is a graceful fish, perhaps the most conspicuous feature of which is its coating of rhomboidal scales, closely fitted together, each covered on its surface with a shining layer of enamel-like modified dentine to which it is fashionable, though in the present writer's opinion unnecessary, to apply the special term ganoin. Such scales are known technically as **ganoid**. The fins, both median and paired, show characteristic peculiarities. The former, at first continuous along the dorsal side of the body and round the tip of the protocerical tail (Fig. 155, D), becomes in its dorsal portion divided up into a number of separate

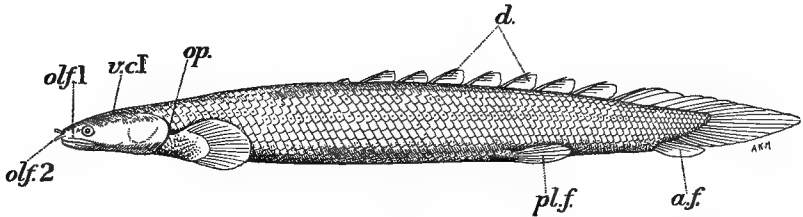

FIG. 152.

Polypterus. *a.f.*, anal fin; *d.*, dorsal fins; *olf.1* and *2*, olfactory openings; *op.*, opercular opening; *pl.f.*, pelvic fin; *v.c.I*, spiracle.

small dorsal finlets (Fig. 152, *d*): hence the generic name *Polypterus*. The pectoral fins are again of a special type known as **crossopterygian**—from the fact that the thin portion of the fin forms a kind of fringe round the edge of a thick, fleshy, scale-covered basal lobe—in contrast with the **actinopterygian** type seen in the great majority of fishes where there is no such fleshy lobe.

As regards the alimentary canal the first thing to notice is that the mouth opening has in the adult, as is the case in the Teleostei, become shifted from the ventral side of the head to the tip of the snout. Into the buccal cavity there opens in the middle line of its roof a gland which can be recognized as the pituitary body. This therefore retains a very primitive condition in *Polypterus*. The branchial apparatus resembles in its main features that of a teleost but on the other hand it retains the primitive feature that the spiracle is still an open cleft. Its outer narrow slit-like and valvular opening may be seen on the dorsal surface of the head (Fig. 152, *v.c.I*).

One of the most interesting points about the Crossopterygians is the clue they give to the evolutionary origin of the air-bladder so characteristic of the modern teleosts. We find in fact in *Polypterus* in place of a typical air-bladder a deeply bi-lobed **lung** corresponding with that of the higher vertebrates (Fig. 153). This arises in the form of a pocket-like downgrowth of the floor of the pharynx which grows backwards as a pair of horn-like projections—commonly termed the right and left lung. The original communication with the cavity of the pharynx remains as a

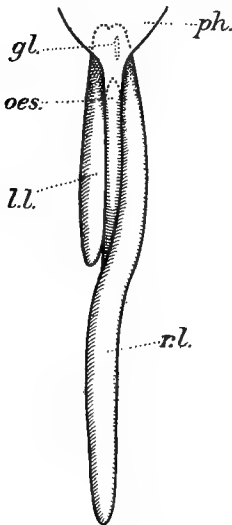

FIG. 153.

Polypterus, dorsal view of lung. *gl.*, Glottis; *l.l.*, left lung; *oes.*, oesophagus; *ph.*, pharynx; *r.l.*, right lung.

longitudinal slit—the **glottis** (Fig. 153, *gl.*)—near the mid-ventral line. Each lung forms a smooth thin-walled sac provided with a network of capillary blood-vessels which enable respiratory exchange to take place between the blood circulating in the network and the air in the lung. The living *Polypterus* visits the surface of the water at short intervals and swallows air which passes through the glottis into the lung; if it is prevented from reaching the surface by wire netting it drowns.

There are certain details about the lung apparatus of *Polypterus* which should be particularly noted for their bearing upon the evolutionary explanation of the teleostean air-bladder.

(1) The apparatus is certainly homologous with the lungs of the higher animals. This is demonstrated by its possessing the three fundamental characteristics of the vertebrate lung: (a) it is in its earliest stages in the form of a mid-ventral outpushing of the floor of the pharynx, (b) it receives its blood supply by a **pulmonary artery** arising from the sixth aortic arch and (c) it is innervated by a special pulmonary branch of the vagus.

(2) While undoubtedly homologous it shows certain differences from the typical lung, associated with the fact that in the adult *Polypterus* it becomes strongly lop-sided—the right lobe or the right lung, to use the ordinary nomenclature, increasing greatly in length (Fig. 154, B, *r.l.*) while the left (*l.l.*) lags relatively behind in its development. In an aquatic creature the lung, filled as it is with air, necessarily acts as a float; and in *Polypterus*, where the body is covered with a coating of

relatively very dense and heavy scales and where the rest of the bony skeleton is also very dense, this action must be peculiarly important. But this floating effect necessitates that the lung apparatus as a whole must be approximately symmetrical about the mesial plane as otherwise the creature would be tilted over on one side. Now in *Polypterus* the original symmetry is lost through the relatively greater increase in the size of the right lung. As a corrective to this the hinder portion of the right lung, having no left lung to balance it, loses its right-hand position and grows back along the mid-dorsal line (Fig. 153, *r.l.*). This hinder portion of the right lung then lies mesially, while the front portion, balanced by the small left lung, retains its primitive right-hand position. It is clear that if the left lung were to continue to shrink still further in relative size, to the verge of complete disappearance, a larger and larger proportion of the right lung would take up a mid-dorsal position until the whole became mesial. A condition would thus be reached identical with

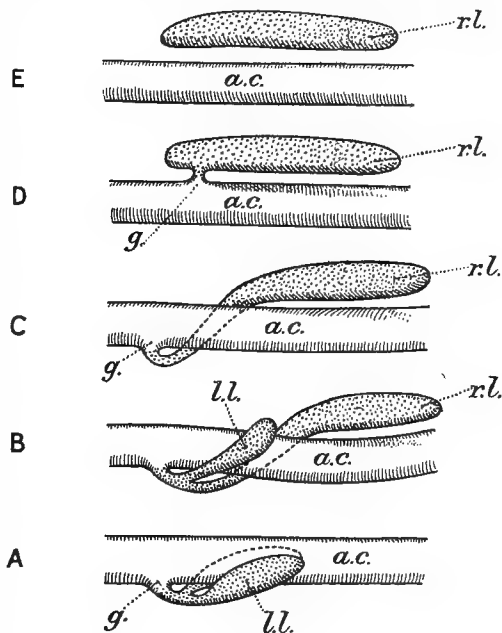

FIG. 154.

Diagram illustrating the lung in Fishes; as seen from the left side. A, Primitive symmetrical arrangement; B, *Polypterus*; C, *Ceratodus*; D, physostomatous Teleost; E, physoclistic Teleost. *a.c.*, Alimentary canal; *g.*, glottis; *l.l.*, left lung; *r.l.*, right lung.

that of the air-bladder of a teleost except that the air-bladder would still communicate round the right side of the alimentary canal with a ventrally placed glottis. That this reasoning is correct is indicated by one of the lung-fishes (*Ceratodus*, p. 375) which actually possesses such an arrangement (Fig. 154, C). To attain to the arrangement of a physostomatous teleost all that is now needed is for the communication between air-bladder and glottis to become shortened, as on the principle of economy of tissue—one of the great principles of animal development—we should expect it to do. For this would involve the glottis becoming

displaced round the right side of the alimentary canal until it was dorsal and so in the closest proximity to the air-bladder (Fig. 154, D).

The typical lung is innervated, as has been mentioned, by pulmonary branches from the two vagus nerves. Now in *Polypterus* with the great increase in size of the right lung a share in its innervation has been handed over to the pulmonary branch of the left vagus, the main trunk of which is continued backwards *dorsal* to the alimentary canal to be distributed over the left-hand portion of the right lung. This curious arrangement of the pulmonary nerves in *Polypterus* is of great importance for understanding the arrangement in the Lung-fishes.

The intestine of the Crossopterygii is short and it retains the spiral valve seen in the Elasmobranch. An interesting detail is the presence of a pyloric valve in the form of a spout-like projection of the stomach into the commencement of the intestine, for if the space round this spout were to become divided up into a number of separate pockets opening into the commencement of the intestine at their hinder ends we should have an arrangement like the pyloric caeca of the teleost, and it has been suggested that these very characteristic organs have so arisen in evolution.

The kidney of the Crossopterygian during the larval stage is a pronephros, with as a rule two tubules on each side, but in the adult the place of this is taken by an opisthonephros which retains the relatively primitive elongated slender form.

There are two ovaries: the eggs are numerous and small in size, about 1 mm. in diameter, and the oviducts are short Müllerian ducts—pointing to the probability that the ancestors of teleostean fishes also possessed typical Müllerian ducts.

The testis is of special morphological importance. In the young larva it forms an elongated ridge of the coelomic lining but only a comparatively short portion at the front end becomes functional. The hinder and much longer sterile portion has in the adult the appearance of a simple duct and it functions as such, and it is only on examining its minute structure and development that it becomes apparent that it is really a degenerate portion of the testis. It opens at its hind end into the duct of the opisthonephros.

The skeleton of *Polypterus* is in the adult very completely bony.

In connexion with the blood-system the only point requiring special mention is that the conus arteriosus remains muscular and that it possesses in its interior numerous pocket-valves arranged in longitudinal rows.

Turning to the nervous system we should naturally look at those parts of the brain that in the Teleost show specially striking peculiarities, namely the cerebellum and the hemispheres. Both of those show in-

teresting features. The cerebellum is large and well developed, but it is hardly visible when the brain is viewed as a whole, for it is completely involuted into the interior of the brain, there being not only a valvula cerebelli as in the teleost but the hinder portion being similarly involuted backwards into the fourth ventricle. So also with the hemisphere region: the thalamencephalon is prolonged forwards, and the side walls of the anterior portion, corresponding to the hemispheres, are much

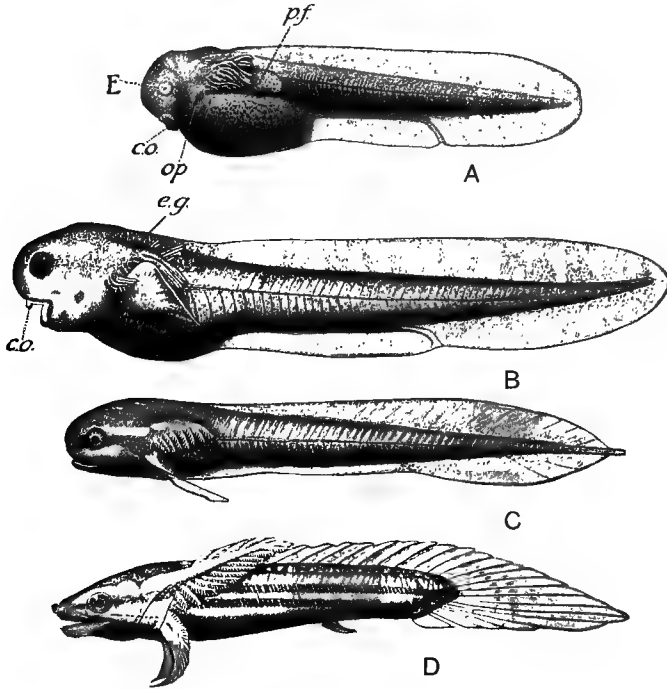

FIG. 155.

Larval stages of *Polypterus*. (From Graham Kerr's *Embryology*, after drawings by Budgett.) A, stage 31; B, 33; C, 36; D, larva 30 mm. in length. *c.o.*, Cement-organ; E, eye; *e.g.*, external gill; *op*, operculum; *p.f.*, pectoral fin. (A, B $\times 11$; C $\times 8$.)

thickened and bulge inwards so as to be completely concealed in external view. This modification clearly paves the way towards the condition in the typical Teleost where the corresponding brain-material forms a solid mass projecting inwards into the cavity of the brain.

The Crossopterygians of to-day are the surviving remnants of a group of extremely archaic vertebrates and consequently it is of much interest to inquire how they develop. The young *Polypterus* passes through the characteristic larval stages shown in Fig. 155. The most striking feature

is the presence of two types of organ which we have not met with hitherto—**external gill** and **cement-organ**. The former, shown at the height of its development in Fig. 155, D, is a feathery projection from the hyoid arch, richly supplied with blood by the second aortic arch which loops out into it. It forms the main respiratory organ of the larva but completely disappears before the adult condition is reached. The cement-organ is a gland producing a sticky secretion by means of which the young *Polypterus* hangs on to water-plants or other objects. It is conspicuous in early larval stages (Fig. 155, A, *c.o*) but soon disappears without leaving a trace behind. The organ contains a deep pit opening at its tip and lined by glandular epithelium, and embryological study brings out the remarkable fact that this glandular epithelium is originally a part of the endodermal lining of the alimentary canal which grows out into a pocket and becomes continuous with the outer ectoderm while it loses its primitive connexion with the alimentary canal. There is clearly some interesting evolutionary secret underlying this peculiar mode of development.

More closely allied to the modern teleosts than are *Polypterus* and *Calamichthys* are the few more or less archaic genera which are grouped together as the GANOIDEI or actinopterygian ganoids. These include the ordinary Sturgeons (*Acipenser*—Fig. 156), which make their way up the rivers of the Northern Hemisphere to spawn, and the ovary or “roe” of which is well known as caviare; the Shovel-bill Sturgeon (*Polyodon*) of the Mississippi; and *Psephurus* of the Yang-tze-Kiang. The Garpike (*Lepidosteus*—Fig. 157) and the Bowfin (*Amia*—Fig. 158) of North American fresh-water lakes are also included in the Ganoidei.

The chief interest of these fishes lies in their retention of various features characteristic of Elasmobranchs and Crossopterygians. In the Sturgeons the mouth retains its primitive ventral position: in all the tail is more or less markedly heterocercal. In the Sturgeons the skeleton is cartilaginous, except that there are well-developed plates of bone in the skin and that the cartilaginous cranium is reinforced by bony plates applied to its surface. In *Amia* and *Lepidosteus* the cartilage of the skeleton becomes as extensively replaced by bone as in a typical teleost. So far as the vertebral column is concerned ossification has gone further in *Lepidosteus* than in any other fish, the centra having come to fit closely into one another, the convex anterior face of the centrum fitting into the concave posterior face of the next vertebra behind it (**opisthocoeleus**) whereas in the teleost the centra are amphicoelous, with intervening spaces occupied by persistent notochord. In *Lepidosteus* there are ganoid scales

resembling in general appearance those of *Polypterus*, while in *Amia* the scales have become cycloid. A physostomatous air-bladder is present but an interesting relic of its ancestral history is seen in the fact that in



FIG. 156.

Acipenser. $\times \frac{1}{2}$. (From Bashford Dean.)

Amia it still receives its blood from typical pulmonary arteries, though it is to be noted that their arrangement has become modified in the same direction as was seen in the nerves of the right lung of *Polypterus*—

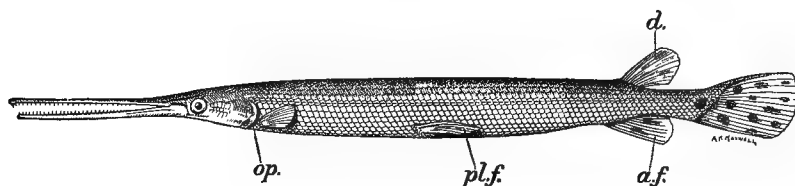

FIG. 157.

Lepidosteus. $\times \frac{1}{3}$. a.f., Anal fin; d., dorsal fin; op., opercular opening; pl.f., pelvic fin.

the left pulmonary artery passing direct to the left side of the air-bladder and the right artery direct to its right side.

In the Sturgeons an open spiracle is still present but it has disappeared

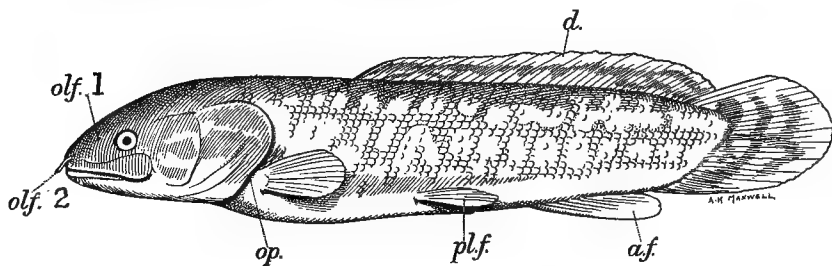

FIG. 158.

Amia. $\times \frac{2}{3}$. a.f., Anal fin; d., dorsal fin; olf. 1 and 2, olfactory openings; op., opercular opening; pl.f., pelvic fin.

in the other actinopterygian ganoids. The post-spiracular gill-clefts are covered in by an operculum and there are no external gills at any period of development. As regards the rest of the alimentary canal—there is in the Sturgeons a well-developed spiral valve but in *Amia* and

Lepidosteus only the hind end of this persists as a short vestige. In the Sturgeons again the anterior portion of the cardiac tube retains the form of a rhythmically contractile conus arteriosus containing longitudinal rows of pocket-valves, while in *Amia* the rhythmic contractility and the presence of pocket-valves has become restricted to a comparatively short stretch at the ventricular end, thus leading up to the condition seen in the modern teleost (p. 360).

The tubular connexion between the pericardiac and peritoneal cavities existing in the Elasmobranch is to be found also in the Sturgeon.

Most species of *Acipenser* are anadromous, but the other ganoids are permanent residents in fresh water. The larvae possess cement-organs similar in their nature to those of *Polypterus*.

The three genera *Lepidosiren*, *Protopterus* and *Ceratodus* — grouped together under the name DIPNOI—are the last survivors of an extremely

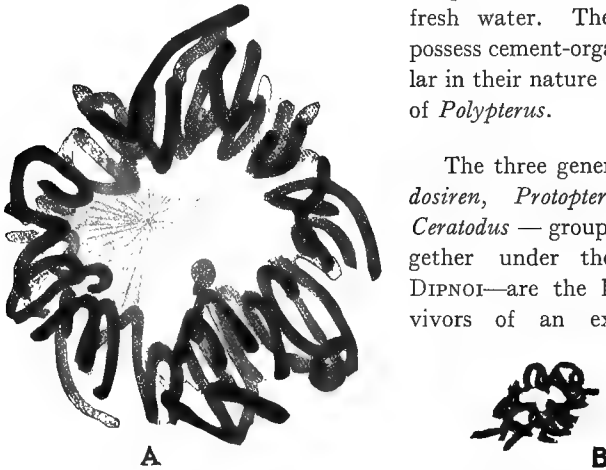

FIG. 159.

Mitosis in *Lepidosiren*—A, and a mammal—B (from Agar). The figures are drawn to the same scale

archaic group of vertebrates which flourished along with Elasmobranchs and Crossopterygians during the remote palaeozoic periods of geological history. They are of great scientific interest from their mixture of features that appear to have been relatively primitive characteristics of the vertebrate phylum with others that foreshadow developments that have taken place in the more highly evolved vertebrates. One of the three genera—*Lepidosiren*—possesses another feature that renders it of much scientific importance, namely that its nuclei and their constituent chromosomes are of a size unequalled in any other vertebrate, indeed so far as is known in any other animal (Fig. 159). This renders it peculiarly adapted for the investigation of the minute details of nuclear structure and one of the most important studies of these details in the repro-

ductive cells, on which the phenomena of inheritance depend, has been made by Agar upon *Lepidosiren*.

The group Dipnoi, represented during ancient geological periods by probably numerous genera and species, distributed widely over the earth's surface, is to-day on the verge of extinction, being represented only by the three surviving genera mentioned above. These afford an excellent example of the discontinuous geographical distribution already alluded to as often characteristic of the present-day representatives of ancient groups of animals, for they inhabit respectively the swamps of tropical South America (*Lepidosiren*), and of tropical Africa (*Protopterus*), and the Burnet and Mary Rivers of Queensland (*Ceratodus*). The first of these to become known to science was *Lepidosiren*, two specimens of which were brought from Brazil in 1837. The creature remained a great rarity until the 'nineties of last century when its scientific investigation in its native swamps was seriously taken up. *Protopterus* became known very soon after *Lepidosiren*—a preserved specimen in the College of Surgeons' museum in London, brought from the River Gambia, attracting the attention of Owen. For many years *Protopterus* was the best known of the existing Lung-fishes owing to the fact that specimens contained in the dry-season cocoon were frequently sent home to Europe as curiosities. It was, however, not till 1900 that the eggs and larvae were first obtained (by Budgett). The name *Ceratodus* was coined originally for the unknown and supposedly extinct possessor of certain curious fossil teeth which occur in the Rhaetic rocks of Aust Cliff near Bristol. In the year 1869 similar teeth (Fig. 161, A) were observed in the mouth of an undescribed fish sent from Queensland to the Sydney museum, and it was realized then for the first time that *Ceratodus* still existed alive in that remote region. The eggs and larvae of *Ceratodus* were first discovered in 1884 by Caldwell, and their complete investigation, by Semon and his colleagues, followed some years later.

The three surviving Lung-fishes (Fig. 160) possess somewhat cylindrical bodies, stoutest in *Ceratodus* (A) and most slender in *Lepidosiren* (C), tapering off gradually into the compressed tail which retains the primitive symmetrical protocercal form, although in many of the extinct members of the group the tail of the adult was heterocercal, no doubt in correlation with their being more active and skilled swimmers. The mouth is in the adult at the tip of the head. The two pairs of limbs are in *Ceratodus* clumsy pointed paddles of a type (archipterygial) which was predominant among palaeozoic fishes (Elasmobranchs, Crossopterygians, Dipnoi). In the adult *Protopterus* and *Lepidosiren* the limbs have become slender and degenerate.

The scales of the Lung-fish are rounded and overlap like the cycloid scales of Teleosts. They are largest in *Ceratodus*, smallest and deeply buried in the skin in *Lepidosiren*.

The teeth are in the young *Ceratodus* (Fig. 161, B) simple pointed cones like those of a young shark, but as they develop irregular strands of bone spread out from their bases so that they are connected together into groups (Fig. 161, C). With further development the spongework of modified bone which connects the denticles of each group increases in extent and compactness, assumes a ridged form, and constitutes the

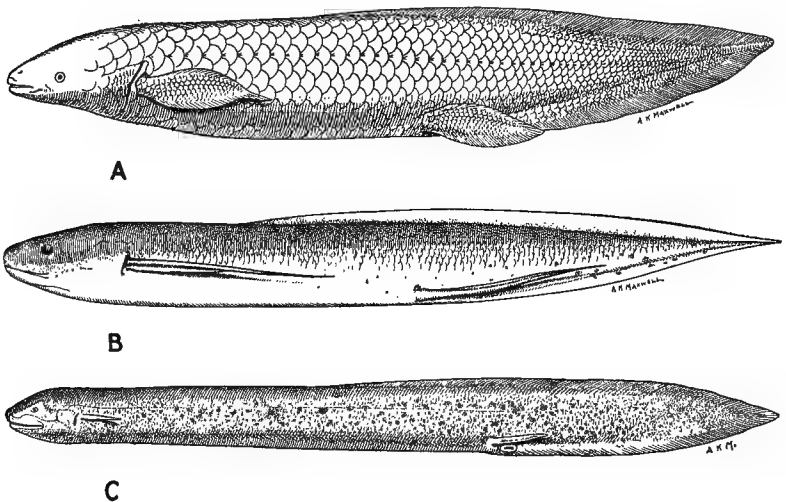

FIG. 160.

Lung-fishes. A, *Ceratodus*; B, *Protopterus*; C, *Lepidosiren*.

characteristic "tooth" of the adult (Fig. 161, A, *t*), the sharp points of the original denticles soon disappearing.

The branchial apparatus is of the usual fish type—the spiracle having disappeared and the remaining clefts being overlapped by an operculum. In *Lepidosiren* the respiratory lamellae are reduced to irregular little projections.

The feature of the Dipnoi which probably in great part accounts for their having been able to survive, in spite of the pressure of competing and more highly evolved fishes, is the high development of the lung as a breathing organ. In the young Dipnoan the lung arises in normal fashion as a downgrowth from the floor of the pharynx which grows backwards, and in the case of *Lepidosiren* and *Protopterus* forks to form

a right and a left lung. An important point which has emerged from the study of its development is that for a time it shows a distinctly lop-sided arrangement as in *Polypterus*, the morphologically right lung being larger than the left. Correlated with this the lung apparatus as it grows backwards becomes twisted round the right side of the alimentary

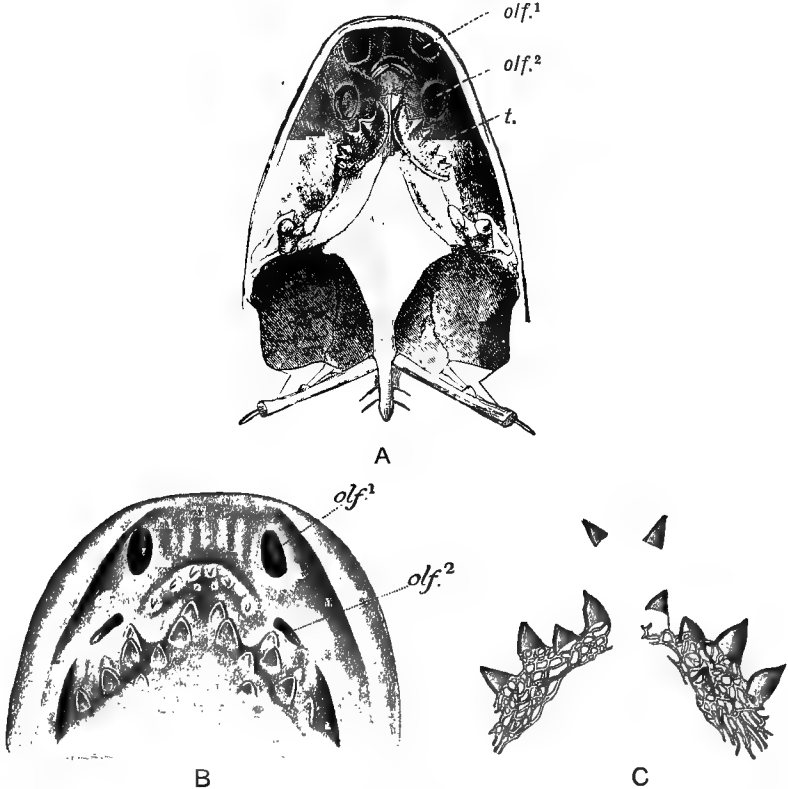

FIG. 161.

Ceratodus. A, Ventral surface of skull of adult; B, roof of mouth of young specimen; C, teeth of roof of mouth of a young specimen. (A, from Zittel's *Palaeontology*, after Günther; B and C, from Graham Kerr's *Embryology*, after Semon.) *olf.1*, Anterior naris; *olf.2*, posterior naris; *t*, compound tooth.

canal until it lies completely dorsal and reversed in position, the original right lung being now on the left side. In *Lepidosiren* and *Protopterus* the lagging behind of the original left lung is only temporary, it soon goes ahead actively with its growth and the two lungs come to be equal in size. In *Ceratodus*, however, no such recovery in the growth activity of the original left lung appears to take place: on the contrary it

dwindles away and eventually all trace of it is lost, there being a single air-bladder—the persistent right lung—precisely as in a teleost except that its cavity communicates with that of the alimentary canal, round the right side of the latter, by means of the still ventral glottis (Fig. 154, C, p. 367). The blood supply of the Dipnoan lung is by a pair of typical pulmonary arteries arising from the sixth aortic arch, and that of the left side still curls round the ventral side of the alimentary canal to the right side, thus marking out the track of the lung as it became twisted from its original ventral to its definitive dorsal position. We should expect the pulmonary branch of the left vagus nerve to pursue the same course but as a matter of fact it crosses the right in an X-like manner dorsal to the alimentary canal—a fact which seemed to constitute an insoluble morphological puzzle until the investigation of *Polypterus*, in which the lung retained a condition assumed to be ancestral to that of the lung-fishes, showed that in that stage of evolution a direct dorsal connexion had already been established between the right lung and the left vagus.

It is now possible to construct out of the facts that have been mentioned in connexion with the several groups a fairly complete history of the evolutionary changes undergone by the lung of fishes (see Fig. 154, p. 367).

It had at an early stage of its evolution, as shown by the early stages of development in Crossopterygians and Lung-fish, the form of a bilobed pocket of the ventral wall of the pharynx: i.e. it was identical with the lung of terrestrial vertebrates (Fig. 154, A). As evolution proceeded the left lung underwent reduction in size and this allowed the right lung to twist round the alimentary canal into a dorsal position: this stage is still represented in the adult *Polypterus* and in the young Lung-fish (Fig. 154, B). With the complete disappearance of the left lung the right assumed a completely dorsal and median position except that its duct still passed down the right side of the alimentary canal to the ventrally placed glottis: this stage is perpetuated in the adult *Ceratodus* (Fig. 154, C). Economy of tissue now led to the shortening of the duct so that the glottis came to be dorsal in position: this stage is seen in physostomatous teleosts (Fig. 154, D). Finally the duct became nipped across, giving the condition seen in physoclistic teleosts (Fig. 154, E).

The lung or air-bladder of the Dipnoan necessarily fulfils a hydrostatic function, but it also functions as a breathing organ, so efficient that during the dry season—when the water-pools are charged with putrefying vegetation and the water consequently useless for gill breath-

ing (*Ceratodus*), or when on the other hand the waters have completely dried up and left the lung-fishes ensconced in their burrows in the dry mud (*Lepidosiren*, *Protopterus*)—it is able to meet the entire respiratory requirements.

The digestive part of the alimentary canal is comparatively short and as in Elasmobranchs and Crossopterygians there is a spiral valve. In the young larva (Fig. 162) the endodermal rudiment of the intestine is coiled in a corkscrew spiral. The turns of this later become fused together, a last vestige of the spiral twisting remaining as the spiral valve in the interior. This mode of development suggests the probable evolutionary meaning of the spiral valve occurring in so many archaic vertebrates, namely that it is a last reminiscence of a common ancestor of existing vertebrates in which the intestine was relatively long and spirally coiled.

The kidney of the Lung-fish during larval stages is a pronephros, usually with two tubules on each side when at the height of its development. In the adult this is replaced by a long narrow opisthonephros, the ducts of which fuse together at their hind ends to form a dilated bladder or caecum opening into the cloaca on its dorsal side.

The male reproductive organs are of special interest. The testes are somewhat cylindrical bodies which stretch through the greater part of the length of the peritoneal cavity. Towards their posterior ends they narrow suddenly into a sterile portion and in *Lepidosiren* there pass off from this a series of about half a dozen vasa efferentia which communicate with certain of the tubules close to the hind end of the kidney. In *Protopterus* the general arrangement is similar but here the vasa efferentia are reduced to the last one of the series on each side. In the latter animal the spermatozoa pass from the anterior functional part of the testis back in turn through the slender sterile portion, the vas efferens, the kidney tubule, to the kidney duct and so to the cloaca.

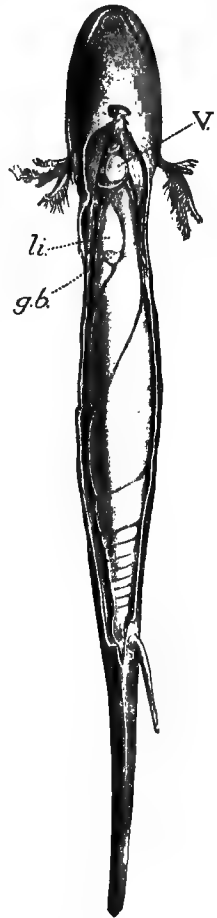

FIG. 162.

Dissection of a larva of *Lepidosiren* showing the spiral coiling of the enteric rudiment. *g.b.*, Gall-bladder; *li*, liver; *V*, ventricle.

The special morphological importance of these arrangements lies in the fact that they demonstrate to us how the peculiar arrangement of the testis and its duct in the Teleostei may have come about in the course of evolution from the more primitive arrangement in which the testis communicates with the opisthonephros through a number of vasa efferentia scattered throughout its length, an arrangement still persisting in such a ganoid as *Lepidosteus* or *Acipenser*. The stages in the process are illustrated in Fig. 163: the degeneration of the hinder end of the testis to form a sterile portion, the restriction of vasa efferentia to

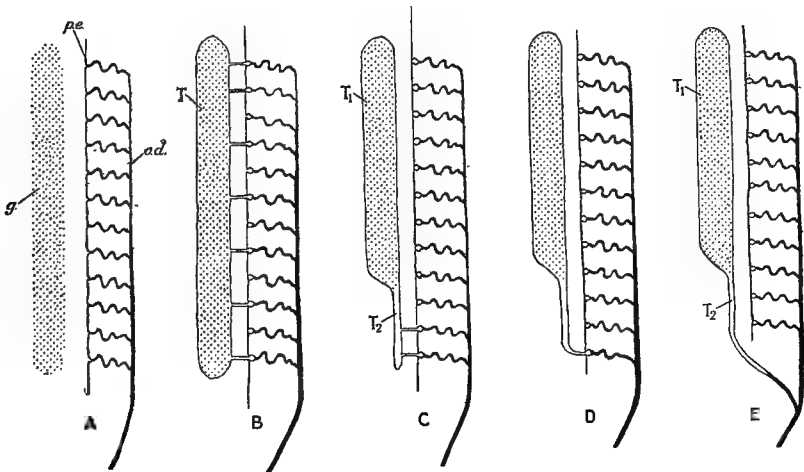

FIG. 163.

Relations of testis and opisthonephros in fishes. A, Hypothetical primitive condition in which the sperms were shed into the peritoneal cavity and passed out by the kidney tubules; B, *Acipenser* in which vasa efferentia are scattered over the length of testis and kidney; C, *Lepidosiren* in which vasa efferentia are reduced to a few connected with the sterile hinder part of testis; D, *Protopterus* in which the vasa efferentia are reduced to a single one at the extreme hind end of testis; E, Teleost in which a kidney-tubule is no longer recognizable as forming part of the channel from testis towards the exterior. *g*, Diffuse gonad; *o.d.*, Wolffian duct; *p.e.*, peritoneal epithelium; T, testis; T₁, functional part of testis; T₂, sterile part of testis.

this portion, the final reduction of the series of vasa efferentia to the hindmost one of the series, and the simplification of the path of the spermatozoa (sterile part of testis, vas efferens, kidney tubule) so as to form a simple short tube leading from the functional part of the testis into the kidney duct.

The skeleton of the Lung-fishes shows one or two extremely archaic features. Thus the notochord persists throughout life and, although its sheath becomes converted into a cylinder of cartilage as in Elasm-

branches, there is no segmenting up of the cartilage to form centra: it remains continuous, except in a short portion near its posterior end.

Again the protocercal tail is supported by a skeleton of a very primitive type consisting of parallel rays of cartilage, each segmented into three pieces, which are simply elongated neural and haemal spines. In the other groups of fishes in which the tail has attained to a higher grade of evolution the supporting rays have become crowded together and modified so that at least on the dorsal side their relation to the vertebral arches is no longer apparent.

The paired fins or limbs again show a type of skeleton which there is much reason to believe is the most archaic and most nearly primitive

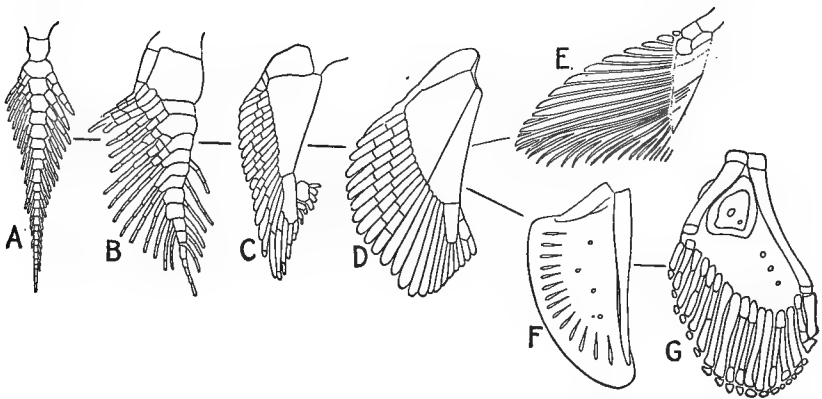

FIG. 164.

Skeleton of the pectoral fin of various fishes. A, *Ceratodus*; B, *Pleuracanthus*; C, embryo Dogfish; D, *Acanthias*; E, Fossil shark (*Cladoseleche*); F, *Polypterus* larva; G, *Polypterus*. The outer or pre-axial side of the limb is to the left, except in A.

type of limb skeleton existing in any living vertebrate. The skeleton (Fig. 164, A) consists of a segmented tapering rod of cartilage, attached to the limb girdle by its base, and bearing on each side a series of segmented cartilaginous rays. The main reasons for regarding this **biserial archipterygium**, as it has been called, as the most nearly primitive of existing types of limb skeleton are the following: (1) It occurs in the paddle of *Ceratodus*—a relatively clumsy, inefficient type of limb, obviously in a very low grade of evolution as a propelling organ compared with the thin flat fins, with muscles concentrated towards the base, found in the other fishes. (2) As we trace the main groups of fishes—Elasmobranchii, Teleostomi and Dipnoi—back in geological history we find that in early ages this was the predominant type of limb in all three groups. Consequently we are forced to conclude either (a) that this type of limb

was really primitive, and common to the ancestors of all three groups, or (b) that it had been evolved independently in the three groups. But we cannot suppose the latter would have happened unless this form of fin were a peculiarly efficient one—in which case it is conceivable that limbs of a different type might have independently become gradually moulded into this form in the different groups—and we know that it is *not* an efficient type of fin, both from what can be observed in the living *Ceratodus* and because we know that in the course of ages it has become completely supplanted in the more successful groups of fishes—the Elasmobranchs and the Teleostomes—by the other type of fin.

(3) There is no great difficulty in interpreting the other types of limb skeleton on the hypothesis that they have been evolved out of a biserial archipterygium. Thus in the ancient sharks of the family Pleuracanthidae (Fig. 164, B) the pectoral fins had become laid back alongside the body and, in correlation with this, the lateral rays on the side next the body had disappeared except a few towards the tip. At the same time the axis had become stouter and its component blocks of cartilage larger and fewer. The condition in a young Dogfish (Fig. 164, C and D) is readily correlated with that of *Pleuracanthus*—the axis now completely embedded in the body-wall, the inner set of rays completely gone except for a few vestiges near the tip in the young embryo, the outer set of rays on the other hand much enlarged and forming the whole support of the projecting part of the fin. Even the fin-skeleton of *Polypterus* (Fig. 164, G) is readily derived from the archipterygium when the condition in the young larva is taken into account (Fig. 164, F) for it is very easy to read into the continuous plate of cartilage of this stage with its radiating slits, the plan of the archipterygium modified in a similar way to that just indicated for the sharks.

Taking these various points into consideration it is impossible to avoid the conclusion that the fin-skeleton of *Ceratodus* is really extraordinarily archaic and that it is in fact a persistence of the ancestral type from which other existing types of fin-skeleton have been evolved.

In the other two existing Lung-fishes, in correlation with the narrowing of the limb, the lateral rays of the skeleton have become reduced (*Protopterus*) or have disappeared completely (*Lepidosiren*).

A considerable amount of reinforcement of the original cartilaginous skeleton by the formation of bone takes place in the Dipnoi. Neural and haemal arches, limb girdles and cranium become in great part ensheathed in, or replaced by, bone. The jaw skeleton calls for special notice. The skeleton of the hyoid arch does not here, as it does in the

Elasmobranch, play any part in suspending the lower jaw. The upper part of the cartilaginous mandibular arch becomes incorporated in the cranium, forming a support to which Meckel's cartilage articulates directly. Here we have probably the most nearly primitive mode of attachment of the lower jaw to the cranium and we may speak of it as the **protostylic** arrangement. The palatopterygoid cartilage or primitive upper jaw skeleton has practically disappeared from development (Agar), and we may probably attribute this to the precocious development of the bony trabeculae connected with the tooth bases, which spread rapidly

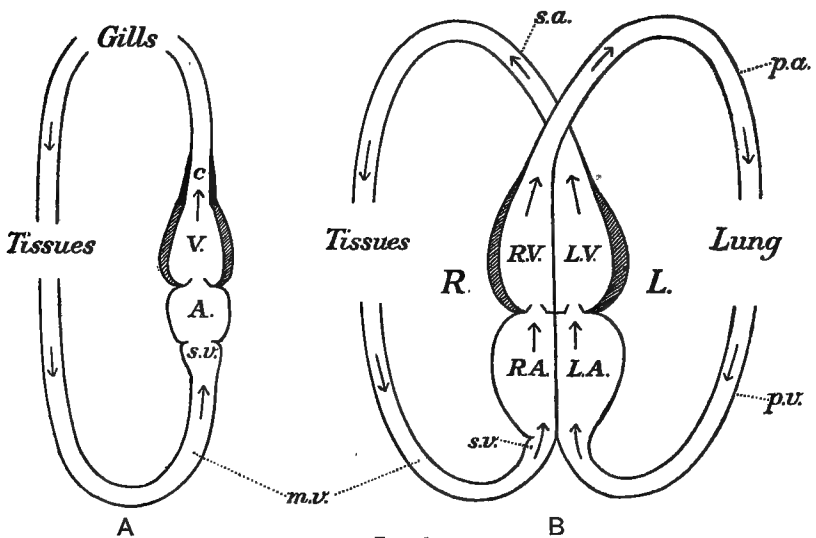

FIG. 165.

Diagram illustrating the essential differences between the "single" (A) and "double" (B) types of circulation. *A*, Atrium; *c*, conus arteriosus; *L.A.*, left auricle; *L.V.*, left ventricle; *m.v.*, main vein returning blood to heart; *p.a.*, pulmonary artery; *p.v.*, pulmonary vein; *R.A.*, right auricle; *R.V.*, right ventricle; *s.a.*, systemic aorta; *s.v.*, sinus venosus; *V*, ventricle.

and form a bony upper jaw continuous with the tooth base, so that a cartilaginous upper jaw is no longer necessary.

In the Dipnoi we find for the first time what is known as a **double circulation**, i.e. one in which a special circuit is arranged for taking the blood through the respiratory organ instead of this latter being simply intercalated in the course of the general circulation.

In a single circulation such as that of a fish the blood passes from the ventricle (Fig. 165, A, *V*) towards the respiratory organs, in this case the gills, and after traversing these and becoming oxygenated it is

carried by the arterial trunks to the tissues and from these it passes back through the veins to the atrial portion of the heart (*A*).

In the typical double circulation the heart has become divided into right and left halves, isolated from one another by a longitudinal septum—the atrium being divided into a right and left **auricle** (Fig. 165, B, *R.A* and *L.A*), the ventricle into a right and left ventricle (*R.V* and *L.V*) and the conus being split into two tubes which twist round one another in spiral fashion.

The blood starting from the left ventricle passes by the **systemic aorta** (*s.a*) and the arteries which branch off from it to the tissues; it then passes back towards the heart through the veins (*m.v*) and eventually arrives via the sinus venosus in the right auricle. From this it passes by the right auriculo-ventricular opening into the right ventricle and then onwards by way of the pulmonary artery (*p.a*) to the lung. There it is oxygenated and it then passes back to the heart by the **pulmonary vein** (*p.v*), arriving in the left auricle. Passing from this through the left auriculo-ventricular opening into the left ventricle it starts again on its journey towards the tissues.

We thus have two distinct circuits—a systemic and a pulmonary—the one concerned with the circulation through the general tissues, the other with the circuit through the lung, the two circuits crossing one another in the region of the conus. The pumping the blood through the two circuits is effected by the ventricles and as might be expected the left ventricle, having to force the blood through the longer and more complicated circuit involved in the blood supply of the general tissues, is provided with thicker and more muscular walls than the right ventricle which has only to force the blood through the shorter and simpler pulmonary circuit.

The special interest of the Lung-fish heart lies in the facts (1) that it shows us for the first time in the series of vertebrates—though not as yet in absolutely completed form—the modifications characteristic of the double circulation and (2) that it affords valuable evidence as to how these modifications came about in evolution. Taking *Lepidosiren* as our type we find that the atrium is divided into a right and left auricle by a more or less spongy partition (Fig. 166, *s.A*), incomplete at its ventral edge next the atrio-ventricular opening, so that in this neighbourhood the cavities of the two auricles are still in continuity. The partition lies to the left of the opening from the sinus venosus (*s.v*) so that the blood from this chamber of the heart, i.e. the blood which has returned by way of the veins from the general tissues of the body, flows into the right auricle. The blood from the lung on the other hand

brought back to the heart by the pulmonary vein—which opens to the left of the partition—arrives in the left auricle. The ventricular portion of the heart is also divided into a right and a left chamber by a vertical partition (*s.V*) which is simply a continuation of the atrial or auricular septum. This also is not quite complete, an open space remaining at its anterior edge through which the right and left ventricles remain in continuity. The blood from the left auricle when it contracts passes down the left side of this septum into the left ventricle, that from the right auricle passes into the right ventricle.

The splitting of the conus is in the Lung-fishes in an incipient condi-

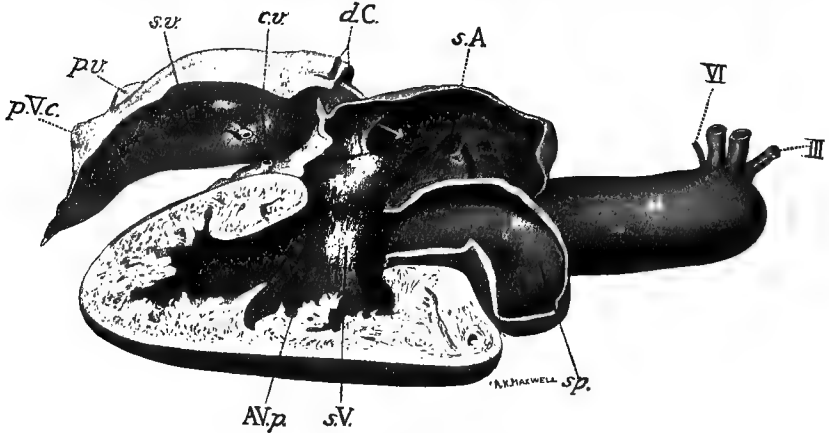

FIG. 166.

Heart of *Lepidosiren* with the right side removed. (After J. Robertson.) *AV.p.*, atrio-ventricular plug; *c.v.*, coronary vein (cut); *d.C.*, ducts of Cuvier; *p.v.*, pulmonary vein; *p.V.c.*, posterior vena cava at its opening into the sinus venosus; *s.A.*, atrial septum; *s.V.*, ventricular septum; *s.v.*, sinus venosus (its opening into the right auricle indicated by an arrow); *s.p.*, spiral valve; *III*, *VI*, aortic arches cut near their ventral ends.

tion and gives valuable clues as to the manner in which this splitting has come about during the evolution of vertebrates. It will be remembered that in Elasmobranch fishes the conus arteriosus contains pocket-valves arranged in longitudinal rows, each row arising from an at first continuous longitudinal ridge which bulges into the cavity of the conus and later segments up into the separate valves. In *Ceratodus* the conus similarly contains longitudinal rows of valves, but in one of these the individual valves are greatly enlarged and form solid blocks in continuity with one another, so as to constitute a large and prominent ridge projecting into the cavity. In other words this row of valves besides having become exaggerated in size may be said to have reverted towards the original condition of a continuous ridge. In *Lepidosiren* an

advance has been made from the condition seen in *Ceratodus*. In the hinder part of the conus the same longitudinal ridge (Fig. 166, *sp*) is seen projecting dorsalwards from the floor of the conus and dividing its cavity incompletely into a right and a left half—continuous when the ventricle contracts with the corresponding halves of the ventricular cavity, owing to the hinder edge of the ridge and the front edge of the ventricular septum becoming approximated together. In the headward portion of the conus a second ridge makes its appearance running along the opposite side of the cavity. It faces the first ridge and the edges of the two are closely approximated and overlap slightly so that the cavity of this portion is practically completely divided into two. As the conus passes forwards into the very short ventral aorta actual fusion takes place so that the two ridges now form a perfectly continuous septum. The two cavities separated by this septum lie not right and left as they did at the cardiac end of the conus but dorsal and ventral, owing to the conus in the middle part of its length having become folded on itself in a peculiar manner. The cavity which is ventral at the front end of the conus is that which is on the left hand at the cardiac end, i.e. it is a continuation of the cavities of the left ventricle and left auricle, the cavities which are filled with oxygenated blood returned from the lung: it may be termed the **systemic cavity** of the conus. The other cavity, lying dorsal to it and continuous with the cavities of the heart containing venous blood, is the **pulmonary cavity** of the conus.

The horizontal floor separating systemic and pulmonary cavities is continued into the ventral aorta and gradually slopes dorsalwards at its headward end, so as to merge into the roof of the ventral aorta. The pulmonary cavity of the ventral aorta thus becomes obliterated at its front end by its floor becoming coincident with its roof.

The ventral aorta is greatly shortened, and the four aortic arches (III-VI) spring from it close together on each side. The horizontal floor which as already mentioned divides the cavity into a systemic and pulmonary portion passes into the roof at a level just between arches IV and V, so that arches III and IV arise from the ventral (systemic) cavity, arches V and VI from the dorsal (pulmonary) cavity. Arches V and VI join together before opening into the aortic root dorsally and the pulmonary artery branches off from the short common portion so formed.

It follows from the arrangements which have been described that the oxygenated blood reaching the heart by the pulmonary vein and the de-oxygenated blood reaching the heart by the sinus venosus have before them two distinct routes. The former is poured into the left auricle and

passes thence through left ventricle, systemic cavity of the conus, and aortic arches III and IV to the aortic roots and so on to the tissues of the body generally. The blood from the sinus venosus on the other hand passes by way of right auricle, right ventricle, pulmonary division of the conus, and arches V and VI, into the common vessel formed by the junction of these. From this it drains away into the pulmonary artery and so to the lung, only an insignificant proportion passing on into the aortic root.

There is thus in *Lepidosiren* a perfectly recognizable double circulation, but the two circuits, pulmonary and systemic, have not as yet become completely shut off from one another. A considerable admixture of the two blood-streams must still take place owing to the splitting of atrium, ventricle and conus into two halves being not yet complete.

The venous system of the Lung-fishes is also of great interest for we find in it for the first time an arrangement of the main venous trunks in the hinder part of the body that occurs in all the higher vertebrates and also a clear indication of the manner in which that arrangement has come about in the course of evolution. In the typical fishes, as in *Scyllium*, the blood from the kidneys and posterior region of the body is carried forwards towards the heart by a pair of posterior cardinal veins which open anteriorly into the outer ends of the ducts of Cuvier. In the higher vertebrates on the other hand this holds only for early stages of development: in the adult the posterior cardinals are reduced or absent in the region in front of the kidneys and the blood passes directly to the sinus venosus by a large new unpaired vein known as the **posterior** (or in Man "inferior") **vena cava**, which arises in the embryo by sprouting out from the veins of the liver. It is in regard to the evolutionary origin of this important vein of the higher vertebrates that the Lung-fishes give us a clue.

There are present in *Lepidosiren* and *Protopterus* the same main venous trunks, as in *Scyllium*. The caudal vein divides into the two renal portals which run forwards along the outer edge of the kidneys. After traversing the kidneys the blood is collected by the two posterior cardinals which pass forwards, communicating with one another here and there by cross channels, to the outer ends of the ducts of Cuvier. Anterior cardinal and subclavian veins also open into the duct of Cuvier. Into the sinus venosus opens the hepatic vein from the liver.

The important new feature of the venous system is correlated with the fact that the kidneys are much elongated and that the tip of the liver has come into intimate contact with the front end of the right kidney. Complete fusion has taken place between the tissues of the two organs

and this fusion has extended to their blood-vessels, their venous channels having come to communicate with one another. As a result of this arrangement, blood flowing forwards in the right posterior cardinal vein when it reaches the level of the front end of the kidney has before it two alternative routes by which it can reach the heart—the original somewhat circuitous route by way of posterior cardinal vein and duct of Cuvier, and a new route direct to the sinus venosus through the venous channels of the liver and the hepatic vein. Very naturally, as it seems, the latter direct route has tended in the course of evolution to supplant

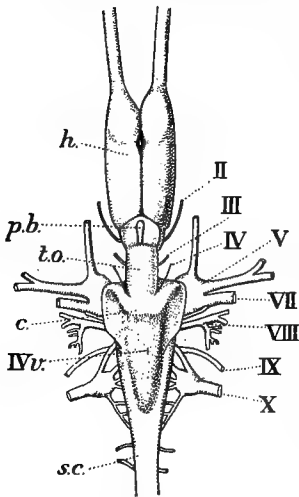

FIG. 167.

Dorsal view of brain of *Lepidosiren*.
c Cerebellum; *h*, hemisphere; *p.b.*, pineal body; *s.c.*, spinal cord; *t.o.*, roof of mesencephalon; *IVv.*, roof of fourth ventricle. Roman figures indicate cranial nerves.

the former. The anterior portion of the right posterior cardinal vein has dwindled away while a wide direct channel has developed through the liver substance, continuous behind with the renal portion of the posterior cardinal and in front with the enlarged hepatic vein. It is this vein, draining the blood from the right kidney and the liver substance, which we now call by the name posterior vena cava.

It has been mentioned that the renal portions of the right and left posterior cardinal veins communicate here and there. These anastomoses are of much importance for they pave the way for a further step in evolution whereby the blood from the left kidney as well as that from the right drains into the posterior vena cava, and the anterior portion of the left posterior cardinal dwindles away just as the right had

done in the Lung-fish. In the higher vertebrates this step foreshadowed in the Lung-fish has actually taken place.

The chief peculiarities of the brain of the Lung-fishes are these. In correlation with the simplicity of the creature's movements the cerebellum remains very slightly developed, in the form of a slight transverse thickening of the brain roof (Fig. 167, *c*). In correlation with the small size of the eyes and comparatively feeble vision the roof of the mesencephalon shows hardly any thickening to form optic lobes (*t.o.*). And finally, perhaps in correlation with the high development of the sense

of smell, the hemispheres (*h*) are of great size—relatively larger than in any other group of vertebrates except the higher mammals such as Man (Fig. 168, *c.H*). Not only are the hemispheres of large size but they show an advance in complexity which is of much interest from its foreshadowing conditions characteristic of the higher vertebrates. One of the chief of these characteristics is that the ganglion-cells in the wall of the hemisphere become arranged in definite layers forming what is known as a **cortex**. Now in *Lepidosiren* the examination of transverse sections through the wall of the hemispheres shows that there already exists a layer of ganglion-cells foreshadowing the cortex of the higher vertebrate (Elliot Smith).

A feature of this archaic type of brain of importance to the student

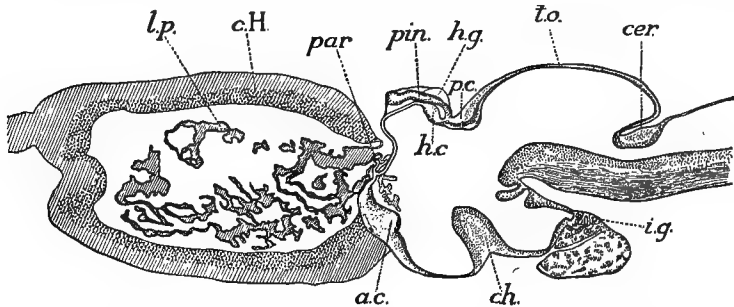

FIG. 168.

Brain of *Lepidosiren* as seen in longitudinal vertical sections. *a.c*, Anterior commissure; *c.H*, hemisphere; *cer*, cerebellum; *ch*, optic chiasma; *h.c*, habenular commissure; *h.g*, habenular ganglion; *i.g*, infundibular gland; *lp*, lateral plexus; *pc*, posterior commissure; *par*, paraphysis; *pin*, pineal body; *lo*, roof of mesencephalon.

is that it shows with peculiar distinctness the main brain-regions which in the higher vertebrates tend to become difficult to recognize but are here spread out diagrammatically in a longitudinal series one behind the other as is shown in Fig. 167. Study of a sagittal section through such a brain (Fig. 168) is peculiarly instructive, showing as it does the main constituent regions of the brain in their primitive relations to one another and at the same time displaying in clear detail features that form important landmarks in brain topography.

In such a section we see at its hinder end the medulla oblongata with its thick floor and membranous roof, the latter becoming thickened anteriorly to form the cerebellum (*cer*). In front of this in turn the brain-roof bulges upwards to form the roof of the mesencephalon (*lo*) its anterior limit indicated by an important landmark—the **posterior commissure** (*pc*). In front of this lies the roof of the thalamencephalon,

the pineal body (*pin*) projecting forwards from it. On each side of the pineal body, and therefore slightly outside the plane of the section, the brain-roof thickens to form the **habenular ganglion** (*h.g.*), the two ganglia being connected by the **habenular** (or "superior") **commissure** (*h.c.*) which lies in front of the root of the pineal body. Apart from the habenular ganglia the roof of the thalamencephalon is in great part thin and membranous. The floor of the thalamencephalon is seen to dip downwards and backwards to form the infundibulum, the solid mass fused with its tip being the pituitary body. The cavity of the infundibulum is demarcated in front by a prominent transverse ridge (*ch*)—the optic chiasma. The deep recess in front of the chiasma is the optic recess. The front wall of the thalamencephalon is traversed by a large and important mass of nerve fibres, forming a bridge between the two hemispheres and known as the **anterior commissure** (*a.c.*), and just above this the brain-wall projects outwards in the median plane as the **paraphysis** (*par*)—an organ of unknown significance.

The hemispheres, like the habenular ganglia, are paired organs and would not therefore appear in a strictly sagittal section, but to make Fig. 168 complete the hemisphere (*c.H*) is shown as it would appear in a section somewhat to one side of the mesial plane. It will be seen that the hemisphere contains a wide cavity—the lateral ventricle—and that the wall enclosing this is of fairly uniform thickness. In particular it will be noticed that the roof (**pallium**, or mantle of the hemisphere) is thick and well-developed.

It has already been mentioned that certain parts of the brain-wall—namely the roof of the Third and Fourth ventricles—are reduced to the form of a thin membrane. The object of this would appear to be to facilitate diffusion-processes between the lymph filling the cavities of the central nervous system (cerebro-spinal fluid) and the blood, as a rich network of blood-vessels (choroid plexus) lies in close apposition to these thin portions of brain-wall. Now in the case of the hemisphere a small portion of its wall, close to its hinder end, similarly assumes this form and together with its plexus of blood-vessels bulges inwards into the hemisphere and eventually forms a complex and irregular **lateral plexus** (*l.p.*), with a very large area of surface through which diffusion can take place. Clearly we have here an arrangement for ministering to the needs—respiratory, nutritive and excretory—of the hemisphere wall.

As shown in the figure an extension of the lateral plexus projects back into the third ventricle. In the higher vertebrates this is continuous across the mesial plane and is termed the *velum transversum*.

The Lung-fishes possess the same equipment of sense organs as the

other fishes. The olfactory organ calls for special mention as its mode of development shows features that are of importance in relation to conditions met with in the higher vertebrates. As in other cases the olfactory organ is morphologically an ingrowth of the ectoderm of the lower surface of the head in front of the mouth. In the larva of *Protopterus* the opening of this becomes elongated and then assumes the outline of a dumb-bell, the central portion becoming narrow and slit-like (Fig. 169, B, *olf*), and finally becoming obliterated so that the cavity of the organ now has two separate openings (Fig. 169, C, *olf*¹ and *olf*²). Here we have established for the first time what in the higher vertebrates

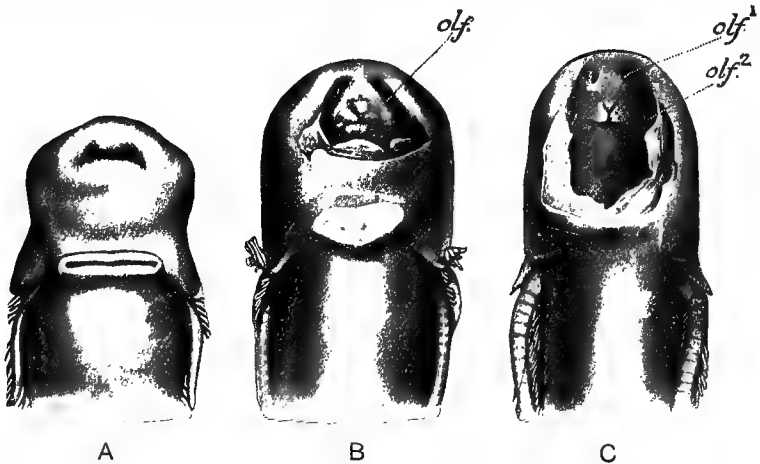

FIG. 169.

Roof of mouth in larvae of Lung-fish (*Protopterus*) to show the division of the olfactory opening into anterior and posterior nares. *olf*, Undivided olfactory opening; *olf*¹, anterior naris; *olf*², posterior naris.

are termed the anterior (or external) and the posterior (or internal) **nares**. In these higher vertebrates the ridge forming the anterior boundary of the buccal cavity passes between the two openings on each side so that the external naris is left on the outer surface of the head while the internal naris is enclosed within the buccal cavity. Terrestrial vertebrates are enabled by this arrangement to breathe through the nose: the Lung-fish, however, has not got this length. It breathes through the mouth and uses the new arrangement of its olfactory organ merely as an adjunct to its sense of smell, for so-to-say sniffing the water—more especially in its search for food.

The Lung-fishes deposit their eggs amongst water-plants (*Ceratodus*) or in burrows at the bottom of the swamp (*Lepidosiren*, *Protopterus*).

In the latter case the male parent remains on guard in the burrow. In *Lepidosiren*, where the gills are inefficient and degenerate and pulmonary respiration essential to life, a unique arrangement is found whereby the male is freed from the necessity of deserting its charge and going to the surface to take in a breath of air. This consists in the hind limb becoming converted into a temporary gill with long respiratory filaments richly supplied with blood. These filaments sprout out at the commencement of the breeding season and then rapidly atrophy when no longer required. In rare cases (Fig. 170) the pectoral limb undergoes a similar modification. The egg develops into a larva of a type closely resembling that of the next group—the Amphibia.

The larva (Fig. 171), except in *Ceratodus*, is provided with four external gills on each side, projecting from visceral arches III, IV, V and VI. Each gill is when fully developed pinnate in form, is richly supplied with blood—the aortic arch being diverted out into it in the



FIG. 170.

Male *Lepidosiren* showing respiratory limbs.

form of a loop, and it is provided with muscles by which it can be flicked actively so as to renew the water in contact with its surface. In all these three features the external gills agree with those of Cross-opterygians and Amphibians. The external gills are the main organs of breathing during larval life but they eventually, sooner (*Lepidosiren*) or later (*Protopterus*), disappear completely.

One of the most interesting problems connected with the evolutionary history of the Vertebrata is that of the origin of the two pairs of limbs which constitute such a characteristic feature of the group. How did the limbs make their first appearance; from what pre-existing organs have they evolved? Whatever was the function of the forerunners of the limbs we are probably justified in believing (1) that they were organs which projected beyond the general surface of the body and (2) that they were freely movable by means of muscles. Now the external gills are the only organs of archaic vertebrates which fulfil these conditions satisfactorily. There is some reason to believe that there were present in the primitive vertebrate a series of external gills extending back behind the region of the body which in the modern vertebrate is concerned with the function of respiration. And it has been suggested that

two pairs of these external gills have survived in the modern vertebrates owing to their having developed supporting and locomotor functions in place of their original respiratory one and that these have evolved into the two pairs of limbs. This interesting problem is gone into in detail

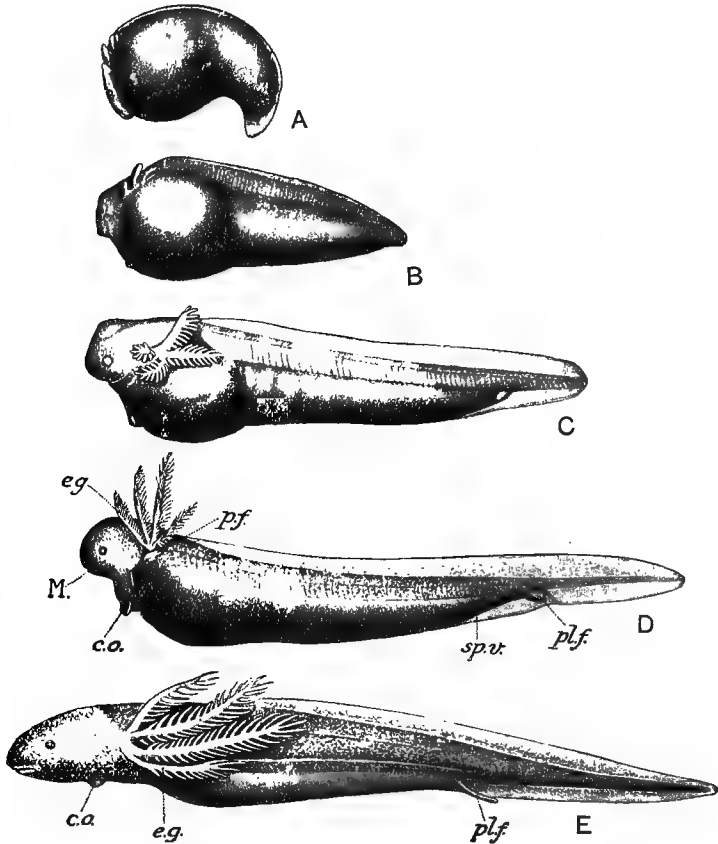

FIG. 171.

Larval stages of *Lepidosiren*. c.o, Cement-organ; e.g, external gill; M, mouth; p.f, pectoral fin; pl.f, pelvic fin; sp.v, spiral valve of intestine. (A-D $\times 3$; E $\times 2.5$).

in my *Embryology* and all that need be said here is that in my opinion the balance of probability is on the side of this "external gill" hypothesis being actually the true theory of the evolutionary origin of the vertebrate limbs.

Except in the case of *Ceratodus* the dipnoan larva also possesses a characteristic cement-organ (Fig. 171, D, c.o.)—a large cushion-like structure

under the throat and therefore behind the mouth instead of in front as it is in the ganoids. In the Lung-fish the cement-organ develops out of a local thickening of the ectoderm so that any connexion with the endoderm—which once existed unless we assume that the cement-organ here is not homologous with that of ganoids—has completely disappeared. Like the external gills the cement-organ is a purely larval structure which disappears later without leaving a trace behind.

In addition to the typical fish of the groups Elasmobranchii, Teleostomi and Dipnoi there must be included in this chapter two groups of creatures, more lowly organized than the true fishes, which are often looked upon as fish in an early stage of evolution but which the present writer regards rather as owing their simpler structure to degeneration and reversion. These groups are the Cephalochorda and the Cyclostomata.

The group CEPHALOCHORDA is formed for the reception of *Amphioxus*

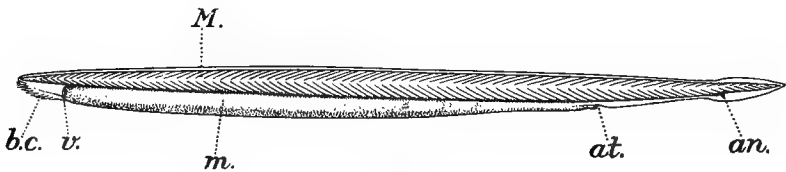

FIG. 172.

Amphioxus. *an*, Anus; *at*, atriopore; *b.c.*, fringe of buccal cirri bounding opening of stomodaeum; *M*, myotomes; *m*, metapleure; *v*, velum.

—a creature that has excited much interest in zoological speculation through its being regarded as a link between vertebrates and “invertebrates.” Although this claim can no longer be allowed *Amphioxus* remains a creature of much interest from its remarkable mixture of features that are indicative of degeneration or specialization for its peculiar mode of life with others that appear to mark a retention of, or a return to, exceedingly archaic conditions.

Amphioxus is a small marine creature measuring about 2 inches in length, pointed towards each end, and somewhat flattened from side to side (Fig. 172). It lives embedded in the sand, making an occasional aimless excursion into the superjacent water but soon sinking down again and showing none of the purposeful wandering from place to place directed by definite psychic activity that is seen in an ordinary fish. In correlation with this the highly differentiated head-region with its equipment of sense-organs and jaws—so conspicuous a feature of the typical vertebrate—is here entirely absent.

Such movement as takes place is carried out in the primitive vertebrate fashion by lateral flexure of the body. In correlation with this the longitudinal muscles are segmented into myotomes—of a simple V-shape, and the edge of the body is extended slightly into a ridge although it is only in the (protocercal) tail region that this is so thin and flat as to be worthy of being called a fin. There is no trace of paired fins but throughout the anterior portion of the body the surface bulges out on each side ventrally to form the **metapleure** (Fig. 172, *m*) enclosing in its interior a large lymph space.

The buccal cavity or stomodaeum is a gaping funnel-like opening on the ventral side anteriorly. It is fringed by a number of slender tentacles or cirri and its lining, especially posteriorly, carries powerful flagella which serve to drive a current of water with floating food-particles back into the pharynx. The boundary between stomodaeum and pharynx is formed by a vertical partition—the **velum** (Fig. 172, *v*)—perforated by a circular opening from whose lips there project back into the pharynx a circle of twelve velar tentacles.

The pharynx is exceedingly large in *Amphioxus* and presents striking peculiarities related in all probability to the nature of the food—microscopic particles floating in the sea-water. The gill-clefts are exceedingly numerous, the series apparently being added to throughout life by the addition of new clefts at the posterior end. Further each cleft, at first rounded in form, becomes split into two by a tongue-like downgrowth from its dorsal wall. The clefts also become greatly elongated in a dorso-ventral direction, forming exceedingly narrow slits, through which water is drawn by powerful cilia on their edges, but which do not permit food-particles to pass. Along the mid-ventral line the pharyngeal floor forms a longitudinal groove or gutter, the lining epithelium being partly ciliated, partly glandular, secreting sticky mucus which passes into the cavity of the pharynx and serves for the entanglement of food-particles. This glandular organ—the **endostyle**—has, as we shall see later, had an interesting fate in the evolution of the more typical vertebrates. The shreds of sticky secretion, laden with food-particles, are carried dorsalwards by ciliary action until they reach a longitudinal groove lying along the roof of the pharynx. The cells lining this are also ciliated and the movement of their cilia produces a current by which the mucus and food-particles are slowly carried tailwards into the intestine.

The intestine is a simple straight tube, somewhat dilated in front to form the “stomach,” which passes back and opens by the anus—situated not in the mesial plane as is most usual in vertebrates but on the left side (Fig. 172, *an*). Close to its front end the floor of the

“stomach” grows out to form a pocket which extends forwards for some distance on the right side of the pharynx. This pocket is of great morphological interest for it represents the liver of the typical vertebrates which in *Amphioxus* retains through life the simple pocket-like form that in other vertebrates is found only in the early stages of its development.

We have seen how in the Teleostomes and Lung-fish the external openings of the gill-clefts become covered in by the opercular flap so that they no longer open on the outer surface of the body but open into the opercular cavity. In analogous fashion the numerous gill-slits of *Amphioxus* open into an extensive cavity called the **atrium** which opens to the exterior by a mid-ventral opening—the **atriopore** (Fig. 172, *at*).

The coelome is in the pharyngeal region reduced to small remnants, its place being in great part occupied by the atrium, but in the intestinal region it is seen surrounding the alimentary canal in normal fashion. The nephridia are short squat organs opening into the atrium near the dorsal ends of the gill-slits. They are unique amongst vertebrate nephridia in two respects: (1) that at their coelomic ends they are provided not with open nephrostomes but with numerous solenocytes (Fig. 75, E, p. 162), and (2) that they do not open into a common longitudinal duct.

Combined with this highly abnormal condition of the nephridia themselves we find in *Amphioxus* complete absence of the genital ducts seen in normal vertebrates. The testes, or ovaries, form segmentally arranged masses which as they increase in size bulge into and finally burst into the atrial cavity, the gametes passing to the exterior through the atriopore. Some of the most important features of *Amphioxus* have to do with its embryology and these will be referred to later in Chapter XIV.

The blood of *Amphioxus* is colourless: the general arrangement of the vessels is on the lines normal to the vertebrate. The chief peculiarity to be noted is that there is no special concentration of the contractility of the sub-pharyngeal vessel in the region of the normal heart but that there are such concentrations at the ventral end of each aortic arch—each arch having developed a special little bulb-like heart of its own.

A notochord is present, enclosed in a thin sheath, and extending from end to end of the body. The peculiarity that it extends to the tip of the head, in which *Amphioxus* is unique, is expressed in the group-name Cephalochorda. The connective tissue of the body—very sparse—acts as a skeleton in places, forming tough envelopes round the notochord and central nervous system, and forming septa between the

myotomes and clear supporting blocks of the median "fin," but there is no modification of the connective tissue to form cartilage or bone. Slender rods of chitin-like material support the pharyngeal wall between the gill-slits, and others support the buccal cirri.

The nervous system possesses the normal vertebrate character of a thick-walled tube, with very small central cavity, lying dorsal to the notochord. But it presents the quite peculiar feature that it is not swollen at its anterior end to form a brain projecting forwards beyond the tip of the notochord. In *Amphioxus* the central nervous system comes to an end some distance behind the tip of the notochord and the only suggestion of brain about it is that the central canal expands to form a considerable cavity at its front end recalling the ventricular cavity of the brain. This cavity frequently dips down ventrally in a manner highly suggestive of the infundibulum and we are probably justified in suspecting that the brainless character of *Amphioxus* is a secondary acquirement, the once-present brain having atrophied, leaving only the ventricular cavity as an indication of its previous existence. Such reduction of the brain during the evolutionary history of *Amphioxus* is readily understandable when we bear in mind (1) the passive method of obtaining the food, and (2) the absence of the great organs of sense.

The group CYCLOSTOMATA includes the lowly and degenerate fishes known as Lampreys (*Petromyzon*—Fig. 173, A) and Hagfish or Borers (*Myxine*—Fig. 173, B; *Bdellostoma*). While the Cyclostomes are primarily marine the Lampreys are anadromous and some species have become permanent inhabitants of fresh water. These fishes further show the remarkable peculiarity, unique amongst vertebrates, of being partially parasitic in their habits, and it is this parasitism which has brought in its train general degeneration and at the same time various specializations of structure.

The general form of the body is eel-like, with a median fin varying in the extent of its development in different genera and continuous posteriorly round the tip of the protocercal tail. There are no paired fins. Another important negative feature of the Cyclostomes is the complete absence of anything of the nature of scales. The skin is soft and glandular, and the Myxinoids possess along each side of the body ventrally a row of very large epidermal glands (Fig. 173, B, g) which produce a sticky glutinous slime. This is produced at will in enormous quantities; it consists of very fine threads and no doubt is valuable as a protection from the attacks of enemies.

The alimentary canal commences with a stomodaeum or buccal cavity

which never develops a hinged jaw apparatus and consequently remains permanently gaping. It is this peculiarity that is expressed in the name Cyclostomata.

The lining of the buccal cavity, and also the piston-like tongue situated within it, bears remarkable spine-like teeth. These are in their structure quite unlike the teeth of any other vertebrate—each consisting simply of a hollow cone of hard cornified epidermal cells (Fig. 174, s).

The pharynx—at the commencement of which is a velum (Fig. 175, v)—carries out as in other vertebrates the function of breathing, but it

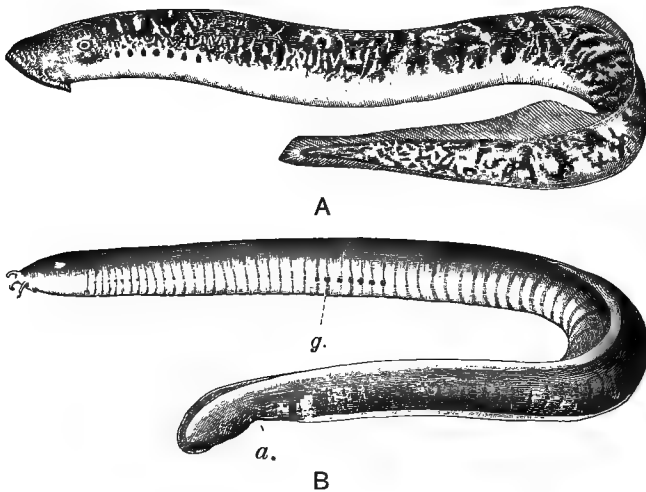

FIG. 173.

Cyclostomes. A, *Petromyzon*—the Lamprey (after Starr Jordan); B, *Myxine*—the Hagfish (from *The Cambridge Natural History*). a, Anus; g, mucus-gland.

shows striking peculiarities, some characteristic of the group as a whole, others characteristic of one or other of its subdivisions. Of the former the chief is that the gill-clefts instead of being literally clefts are rounded sacs, opening internally from the pharynx and externally to the outer surface of the body, the area of respiratory surface being increased by the lining of the sac projecting into its cavity in the form of prominent ridges.

In *Bdellostoma*, or in the larva of *Petromyzon*,¹ these branchial sacs lead straight from pharynx to exterior, but in *Myxine* and in the adult

¹ Known as the *Ammocoetes* larva—having been given the generic name *Ammocoetes* before it was recognized as the larval stage of *Petromyzon*.

Lamprey this arrangement has undergone important modification. In *Myxine* the short tube which normally connects each sac with the exterior has become considerably elongated, and the successive tubes have had their openings shifted backwards along the surface of the body so as to become coincident, at a point on the ventral surface of the body considerably behind the position of the last sac. Consequently a *Myxine* shows not a row of separate gill-openings along each side of its pharyngeal region but merely a single pair of such openings approximated together and situated well behind the region of the pharynx.

In the adult Lamprey the pharynx has become divided longitudinally

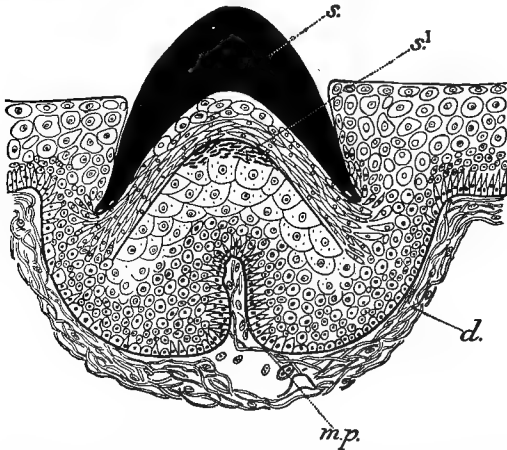

FIG. 174.

Section through tooth of Lamprey (after Warren). *d*, Dermis; *m.p.*, dermal papilla; *s*, functional tooth; *s¹*, new tooth forming to replace *s*.

into a smaller dorsally placed tube continuous with the oesophagus and serving for the passage of food, and a wider ventral respiratory tube (Fig. 175, *r.t.*), carrying the internal openings of the gill-sacs (*v.c.*) and ending blindly at its hinder end. The whole arrangement is very much the same as would come about in an *Amphioxus* if the dorsal ciliated groove which serves for the backward transmission of the food were to become constricted off from the main portion of the pharynx lying below it.

There is another point of great interest about the pharyngeal region of the Lamprey. During the *Ammocoetes*-stage an endostyle is present like that of *Amphioxus* and serving the same function. When, however, the metamorphosis into the adult condition takes place the endostyle becomes constricted off from the pharynx, so as to form a closed sac

lying underneath the pharynx and into which the gland cells continue to pour their secretion. The endostyle has become converted into a ductless gland and that ductless gland is clearly recognizable as the thyroid. Here then by the development of the Lamprey we have light thrown upon the evolutionary history of this organ. The thyroid gland of the Vertebrata would appear to be the persistent and modified endostyle of the ancestral vertebrates in which the secretion was used in connexion with feeding.

As regards the remainder of the digestive tube all that need be said is that it is relatively very simple and undifferentiated. In the ordinary

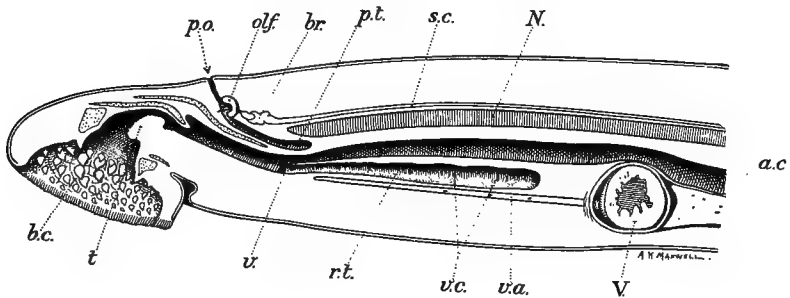

FIG. 175.

Sagittal section through head region of a Lamprey (*Petromyzon*). *a.c.*, Alimentary canal; *b.c.*, buccal cavity; *br*, brain; *N.*, notochord; *olf*, olfactory organ; *p.o.*, pituitary opening; *p.t.*, pituitary tube; *r.t.*, respiratory tube; *s.c.*, spinal cord; *t*, tongue; *V*, ventricle; *v*, velum; *v.a.*, ventral aorta; *v.c.*, internal openings of gill-sacs.

River Lamprey it becomes partially degenerate and non-functional in the adult.

The coelome shows in the Myxinoids the unique peculiarity that there is no demarcation of pericardiac and peritoneal cavities.

The renal organ of the adult Cyclostome consists of an elongated opisthonephros which, however, in the Myxinoids shows a remarkably simplified condition—the individual tubules having become greatly thickened and shortened, so that instead of being intermingled to form a compact kidney they stand out perfectly distinct, appearing as short wide diverticula from the longitudinal duct. The ovary or testis is single and sheds its gametes into the splanchnocoele whence they pass by a minute opening (**genital pore**) through the side wall of the urino-genital sinus into its cavity and thence to the exterior. The morphological meaning of these genital pores is obscure but they may perhaps best be regarded as Müllerian ducts which have gradually become shorter

and shorter, dwindling away until eventually nothing remains but their opening into the urinogenital sinus.

The skeleton of the Cyclostomes shows an interesting mixture of primitive features and features which are clearly specialized. The notochord never becomes replaced by a vertebral column but persists throughout life. Cartilaginous neural arches make their appearance in the Lampreys but they never become completed dorsally. In the Myxinoids they are represented by a continuous plate of cartilage in the tail region, continued into fin rays which support the median fin. Similar fin rays are present in the Lampreys but here they are separate from the neural arches owing to the latter being incomplete dorsally. The cranium is an open trough of cartilage.

The cartilaginous branchial arches instead of being separate hoops have become in the Lampreys joined together to form a continuous basket-work. This is an adaptation to the peculiar method of breathing, rendered necessary by the fact that the ordinary ingress for water—the mouth—is liable to be blocked when the Lamprey is adhering to any solid body. Water is expelled from the pharynx through the gill-openings as in other fishes by muscular contraction of the pharyngeal region. In this process the elastic basket-work is compressed; but as soon as the muscles are relaxed it regains its volume, dilates the pharynx, and so causes an inrush of water through the gill-openings. The Lampreys are unique amongst vertebrates in this feature that the gill-openings serve for inspiration as well as expiration. In the Myxinoids, in which this mode of breathing does not occur, the branchial skeleton has become reduced to inconspicuous vestiges.

The blood system of the Cyclostome is arranged on the same general plan as that of other fishes. The most conspicuous peculiarity is to be found in the venous system—the right and left cardinal veins approaching the mesial plane and undergoing fusion in the neighbourhood of their opening into the duct of Cuvier. This fusion is followed by the complete disappearance of the left duct of Cuvier, so that the whole of the blood from the cardinal veins passes into the heart through the right duct.

The brain is in the Lampreys comparatively primitive as regards its general features. It is much elongated, it is only slightly enlarged as compared with the spinal cord, and its various regions lie in a straight line one behind the other. The membranous non-nervous character of the brain roof which in the Dogfish is seen in the thalamencephalon and medulla oblongata occurs here in the region of the mesencephalon as well. The cerebellum is reduced to a small transverse ridge. The thalamencephalon has two outgrowths from its roof, one in front of the

other—the name pineal being given to the posterior one while the other is termed the **parapineal** or parietal organ. Each of these forms an imperfect eye-like organ, its superficial wall being clear and transparent and its deep wall being retinal in structure, with rods projecting into the cavity of the organ and with nerve-fibres passing from it away towards the brain.

The Myxinoid brain is remarkably different from that of the Lampreys: it is much thicker as compared with the spinal cord and much shorter: in both aspects it is less primitive than that of the Lamprey. The pineal organs are much less developed and there is no trace of eye-like structure.

The pituitary organ of the Cyclostomes is remarkable for the fact that it retains throughout life its opening on the outer surface of the

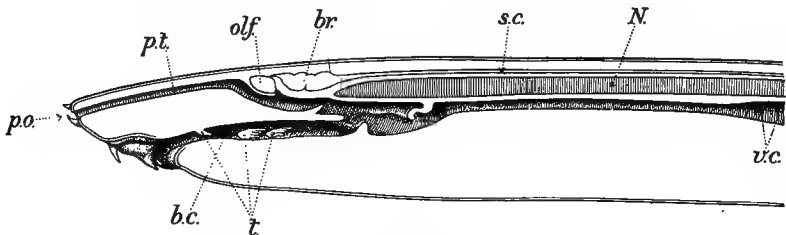

FIG. 176.

The head and anterior part of the body of *Bdellostoma* cut in the sagittal plane to show the relations of pituitary tube and buccal cavity. *b.c.*, Buccal cavity; *br.*, brain; *N.*, notochord; *olf.*, olfactory organ; *p.o.*, pituitary opening; *p.t.*, pituitary tube; *t.*, teeth; *v.c.*, internal openings of gill-sacs.

skin. In *Bdellostoma* the opening is situated at the tip of the head (Fig. 176, *p.o.*) but in the Lampreys it becomes, during the course of development, shifted in a dorsalward direction until it comes to be situated right up on the dorsal side of the head—a considerable distance from the front end (Fig. 175, *p.o.*). In the Lampreys the pituitary organ retains its blind end posteriorly but in the Myxinoids it comes to open into the posterior portion of the buccal cavity (Fig. 176), forming a channel through which the creature takes in the water for respiration.

The great organs of sense have marked peculiarities. The olfactory organs become involved in the ingrowth of ectoderm which gives rise to the pituitary organ and are carried in with it, so that in the adult the olfactory organ (the right and left being fused together) forms simply a kind of pocket on the dorsal or hinder wall of the pituitary tube a little way within its external opening. The eyes in the Myxinoids never complete their development: they remain sunk beneath the skin as more or less embryonic non-functional rudiments. The otocysts also

are comparatively undeveloped, the semicircular canals being reduced to two in the Lampreys and one in the Myxinoids.

Making a general survey of their features we see that these Cyclostomes are a remarkably interesting group of vertebrates. They present an interesting medley of characters—some primitive, some specialized, some doubtful. Among the first we may group the negative features—that the notochord never becomes replaced by a segmented vertebral column, that the cranium does not extend back beyond the origins of cranial nerves IX and X, that the pituitary ingrowth never becomes separate from the outer skin, that in the Myxinoids the pericardiac portion of the coelome does not separate from the peritoneal. Of positive features there is the occurrence of a velum, and in the young Lamprey of an endostyle as in *Amphioxus*.

As specialized features we may interpret the saccular gills, the modifications of the branchial skeleton, the simplification of the kidney in the Myxinoids.

Very doubtful features are the absence of scales and of paired limbs. It is natural to regard their absence as primitive, to regard the Cyclostomes as persisting survivors of the ancient vertebrates which had not yet evolved scales or limbs. But we have seen that in other groups (e.g. Siluridae) a scaly covering may disappear without a trace : we shall see similarly that in vertebrates with elongated bodies it is quite a characteristic feature that their limbs tend to become reduced and eventually to disappear entirely. And there is no convincing evidence that this has not happened in the Cyclostomes.

BOOKS FOR FURTHER STUDY

The Cambridge Natural History, Vol. VII.

Starr Jordan. A Guide to the Study of Fishes.

Goodrich, Fishes, in Lankester's Treatise on Zoology, Part IX.

CHAPTER XI

INTRODUCTION TO TETRAPODA: AMPHIBIA

THE two preceding chapters have dealt with vertebrates adapted to a swimming existence. The remaining members of the phylum—grouped together under the general name TETRAPODA—are on the other hand adapted for progression upon a solid substratum.

The primitive form of body of the tetrapod is probably represented fairly closely by such a creature as a Newt (Fig. 177, A). The pectoral limbs have become shifted back from the head region, the intervening space forming a **neck**, and the hinder portion of the body extends backwards into a tail which remains of the protocercal type. The most characteristic feature, however, of the Tetrapoda is that expressed in their name, the limbs being in the form not of fins but of **legs**, terminating in **feet** which are subdivided up into radiating toes or **digits**, normally five in number. Nothing is definitely known as to the evolutionary origin of this type of limb. The fashionable argument has been that terrestrial vertebrates have evolved out of fish and that therefore legs have evolved out of fins: and many attempts have been made to show precisely how this has come about and how the various skeletal elements in a leg are to be homologized with those in the paired fin of a fish. Such attempts have not led to any general agreement and in fact they appear to be based upon fallacious reasoning, the probability being that existing terrestrial vertebrates have not evolved out of any one of the existing "fish" types, in which the paired limbs are highly specialized for swimming. The probability would rather appear to be that the typical fish and the typical tetrapods of to-day have evolved along diverging lines of specialization from a common ancestral type of primitive vertebrate in which the limbs were neither highly specialized for swimming (fins) nor highly specialized for movement on a solid substratum (legs). These unspecialized limbs were in all probability not far from the simple styliform type still seen to-day in the young

Lepidosiren (Fig. 178). In the initial phases of the specialization of such limbs for terrestrial progression two processes would naturally be especially marked: (1) the spreading out of the tip of the limb to form a foot and (2), in correlation with the increasing rigidity of the supporting

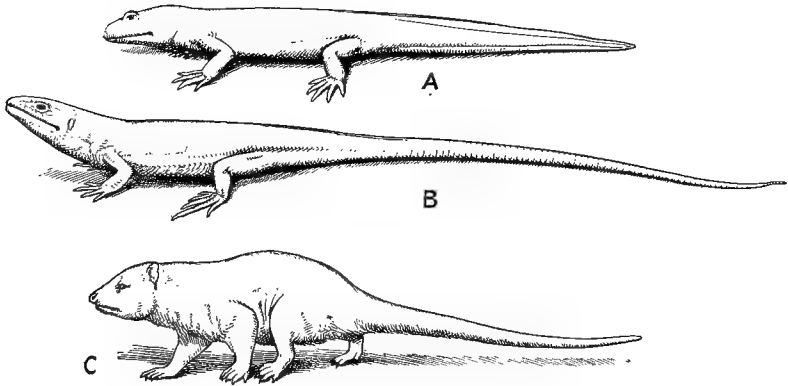

FIG. 177.

Showing the correspondence in general form of the body in the three main subdivisions of the Tetrapoda. A, an Amphibian (a Newt—*Triton*); B, a Reptile (a Lizard—*Lacerta*); C, a Mammal (a thick-tailed Opossum—*Didelphys crassicauda*).

skeleton, the concentration of the at first diffuse flexibility into definite localized **joints**. As regards the first of these it is obvious that the spreading out of the foot into diverging digits with more or less independent movement would make for closer fitting to the solid substratum and consequently firmer support.

As regards the establishment of joints it is of interest to note that when

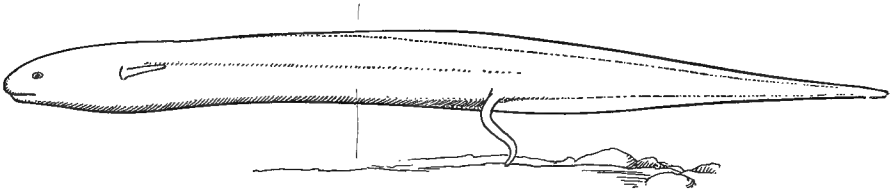

FIG. 178.

Young *Lepidosiren*, showing the flexure assumed by the hind limb when the animal is pushing itself along.

young *Lepidosiren*s are watched clambering about amongst the water-weeds their still flexible hind limbs may be seen to take on a curvature like that shown in Fig. 178—a type of curvature exactly such as would give rise with increasing rigidity of the supporting skeleton to joints at the two points of maximum curvature corresponding to the knee and

ankle—in other words to the type of jointing actually characteristic of the tetrapod hind-limb. We may take it that the hind-limb was the more important in pushing the body forward and it is probably in correlation with this that the fore-limb shows a simpler jointing—the flexure in the wrist region being less marked than that in the ankle.

The limb of the tetrapod is supported by a well-developed bony skeleton which, while showing endless differences in detail, correlated with variations in function, is arranged on a common general plan

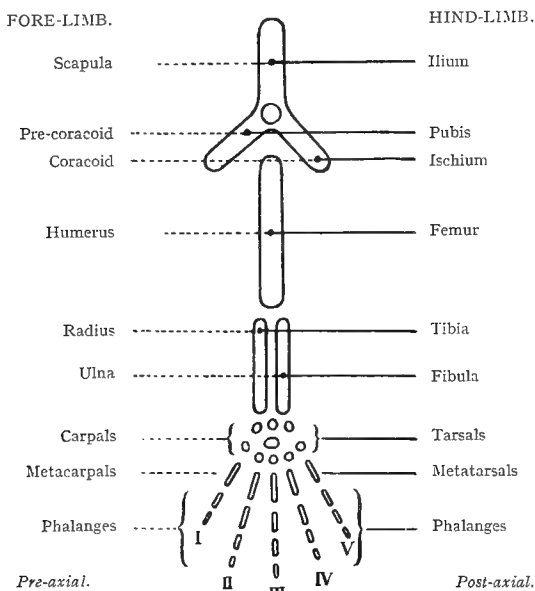

FIG. 179.

Diagram of limb-skeleton of a Tetrapod.

throughout the Tetrapoda. This common plan is shown diagrammatically in Fig. 179. There is a general correspondence between the elements that go to build up the skeleton of the pectoral and the pelvic limb respectively although different sets of names have been allocated to the individual elements as is indicated in Fig. 179.

It should be mentioned that in describing the details of the tetrapod limb it is customary to suppose the limb to be placed in a position corresponding to that of the human arm when extended at right angles to the long axis of the body, with the palm of the hand facing forwards. The straight line passing outwards along the centre of the limb to the

tip of the middle finger is taken as the axis of the limb. The headward margin of the limb in this position is said to be its **pre-axial** margin while the opposite margin is said to be **post-axial**. The thumb is thus the pre-axial digit: the little finger the post-axial. When the digits are indicated by numbers the numbering starts from the pre-axial side: thus the first digit is the thumb, the fifth the little finger.

Each half of the limb-girdle has the form of an inverted Y with a more or less rounded joint surface at the junction of the three branches for the attachment of the limb-skeleton. The single dorsal branch of the girdle is termed in the case of the fore-limb the scapula, in the hind-limb the ilium. Of the two ventral branches the anterior is termed in the fore-limb the precoracoid, in the hind-limb the pubis: the posterior branch is termed in the fore-limb the coracoid, in the hind-limb the ischium.

The pelvic girdle is given firmness by the dorsal end of the ilium bearing against one or more ("sacral") vertebrae, while in the case of the pectoral girdle the tips of the coracoid and precoracoid are attached to the sternum or breast-bone.

The limb of the tetrapod is differentiated into three regions represented in the human being respectively by (1) the upper arm or thigh, (2) the forearm or leg and (3) the hand or foot (cf. Figs. 177 and 180) and each of these has its characteristic skeletal supports, the whole constituting what has been termed the **cheiropterygium** (Huxley) in contradistinction to the "ichthyopterygium" or type of skeleton found in the paired fins of fish.

Articulating directly with the limb-girdle is a long bone—the humerus (fore-limb) or femur (hind-limb). To the end of this (elbow- or knee-joint) are attached two other long bones—the radius and ulna in the case of the fore-limb, the tibia and fibula in the case of the hind-limb. These bones are primitively parallel to one another but the primitive splay-footed condition of the fore-limb tends to become modified by its foot being rotated inwards so as to be more directly underneath the body, and this causes the radius to be twisted round in front of the ulna so as to lie across it in X-fashion.

In the foot itself there is first a group of small bones forming the carpus (=wrist) or tarsus (=ankle). Beyond these are the metacarpals or metatarsals and beyond these in turn are the phalanges contained within the digits—usually two in number in the case of the first digit and three in the others.

AMPHIBIA

SCHEME OF CLASSIFICATION

- I. URODELA (Tailed Amphibians).
Cryptobranchus, Amphiuma, Amblystoma, Salamandra, Triton, Necturus, Proteus, Siren.
- II. APODA (or Gymnophiona—Burrowing, legless Amphibians).
Coecilia, Hypogeophis, Epicrionum.
- III. ANURA (Tailless Amphibians—Frogs and Toads).
Rana, Bufo, Hyla.

The Amphibia form the first subdivision of the Tetrapoda. What may be regarded as the normal form of body is that exemplified by a Newt (*Triton*—Fig. 177, A). From this the Apoda and the Anura have departed in different directions. The former (Fig. 180, B) have taken

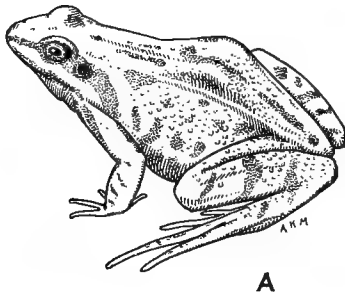

A

to a burrowing mode of life like that of an Earthworm, and in correlation with this the body has become very long and cylindrical, bluntly pointed at each end, and the limbs have completely disappeared except for minute and transient vestiges in the embryo. In the Anura—Frogs and Toads (Fig. 180, A)—on the other hand the body has become specialized for leaping: the hind-



B

FIG. 180.

Aberrant types of body-form in the Amphibia. A, leaping type (Frog—*Rana*); B, burrowing type (one of the Apoda—*Hypogeophis*).

limbs have become greatly developed, their attachment has become shifted far forwards so as to shorten the trunk region, while the tail, large and protocercal in the larva or tadpole, atrophies and disappears completely as the adult form is reached.

The skin has, except for inconspicuous vestiges in a few members of the group, lost all trace of the scales present in the fishes. Its surface is soft and smooth, and is kept moist by the secretion of

numerous epidermal glands. The superficial horny layer of the epidermis is better developed than in fishes and is shed at intervals, being replaced from beneath by a new horny layer. In one or two cases (e.g. in the aquatic toad, *Xenopus*, of South and West Africa) certain of the toes (I, II and III of the hind-foot) have their tips ensheathed in hard, dark-coloured, hollow cones formed by local exaggeration of the horny layer. These are the first representatives of the **claws** which become so conspicuous in the higher tetrapods.

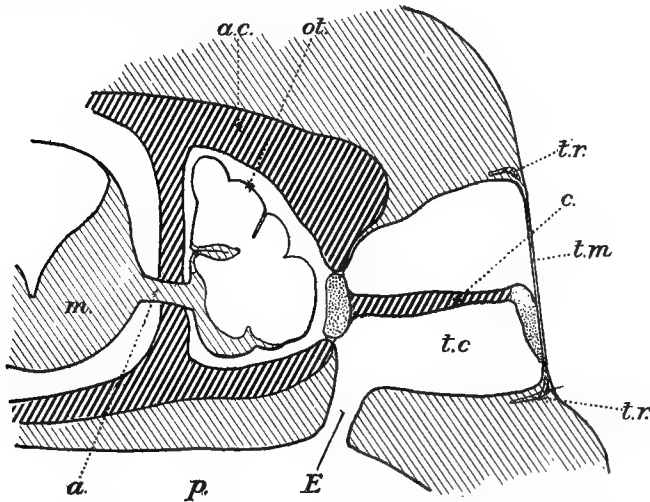

FIG. 181.

Diagrammatic transverse section through one side of the head of a frog, passing through the tympanic cavity. *a*, Auditory nerve; *a.c.*, auditory capsule; *c*, columella; *E*, Eustachian tube; *m*, medulla oblongata; *ot.*, otocyst; *p*, cavity of pharynx; *t.c.*, tympanic cavity; *t.m.*, tympanic membrane; *t.r.*, skeletal ring within which the tympanic membrane is stretched.

The pharynx develops gill-clefts just as in the fishes. Of these the post-spiracular clefts remain functional during the aquatic larval stage but as a rule become completely obliterated later, being covered in by an opercular flap the free edge of which becomes completely fused with the body. The spiracle shows in the Anura among existing Amphibians a remarkable modification in connexion with the sense of hearing which has persisted during the evolution of the higher vertebrates. The gill-pouch becomes dilated at its outer end to form a wide cavity—the **tympanic cavity** (Fig. 181, *t.c.*)—closed in from the exterior by a thin tensely stretched membrane—the **tympanic membrane** or ear-drum (*t.m.*). This membrane is thrown into vibration by sound waves and its vibrations are carried across the cavity by a stiff rod (*c*)—the **columella**—

to a small opening in the skeletal wall enclosing the otocyst. The original communication with the pharynx remains open as the **Eustachian tube** (*E*) which serves to keep the air-pressure equal on the two sides of the ear-drum so as to permit of its free vibration.

The lung-apparatus of the Amphibian consists of a symmetrical right and left lung of relatively small size, lying in the peritoneal cavity and communicating with the pharynx by a ventrally placed glottis. The amphibian method of lung breathing is well seen in an ordinary frog. The mouth is shut, the external nares open, and the floor of the mouth is raised and lowered rhythmically by muscular contraction, an important part being played by the mylo-hyoid—a thin sheet of muscle which passes across from the lower jaw of one side to that of the other. In this way air is passed in and out of the buccal cavity through the olfactory organ. At longer intervals the external nares are closed by a valvular arrangement and now when the floor of the mouth is pressed upwards the glottis opens and the air is forced back through it into the lungs. When pressure is relaxed the air is expelled again through the glottis by the elasticity of the distended lung-wall.

It may be mentioned parenthetically that the respiratory processes of the adult frog are not confined to the lung. The moist skin of the body is richly supplied with blood and active respiratory exchange takes place through it. The same happens with the vascular lining of the buccal cavity which as has been mentioned is rhythmically filled with fresh air. In some of the Salamanders this buccal respiration has become accentuated to such a degree as completely to replace pulmonary breathing and the lungs have in the adult entirely disappeared.

In Amphibians which possess lungs we find that these differ much in their degree of complexity. In a Newt the lung is a simple thin-walled sac with a rich capillary network—an excellent object for observing capillary circulation through the microscope. The newt is killed by destroying the brain and spinal cord and then carefully opened and laid on a microscope slide in normal salt solution, the lung being drawn out to one side so as to permit the microscope to be focused upon it.

In a Frog the lining of the lung is no longer smooth but projects out into numerous little recesses or pockets so as to enlarge the area of the respiratory surface. In a Toad (*Bufo*) the development of these recesses is carried much further, so that the wall of the lung assumes a spongy character.

In those Amphibians which have a well-developed "neck" region the unpaired portion of lung next the glottis is drawn out into a long

tube—the **trachea**. This divides towards its hind end into two branches—the **bronchi**—terminating in the two lungs in the restricted sense.

In many of the Amphibia the wall of the trachea with its cartilaginous supports is modified in the region next the glottis to form a **larynx** or voice-producing organ, the actual sound being produced by the vibration of folds of the laryngeal lining (vocal cords) projecting into its cavity. The sound produced is loudest in the males of various species of Frogs and Toads and its volume is in many cases increased by resonating chambers (croaking sacs) which develop as outgrowths of the buccal lining. The sound differs greatly in quality in different species and in many of those inhabiting the tropics consists of highly musical notes and trills.

As regards the rest of the alimentary canal the only feature that need be mentioned is the appearance of an important new organ—the **allantois**—a thin-walled pocket projecting from the ventral wall of the alimentary canal close to its hinder end and functioning as a urinary bladder in which the secretion of the kidneys accumulates. As will be seen later the precociously developed and enlarged allantois plays a very important part in the embryos of vertebrates above the Amphibia.

The coelomic arrangements show, as compared with those of fishes, an advance which is maintained throughout the higher vertebrates, in that the pericardiac cavity has become as it were telescoped back into the peritoneal cavity, while its bounding wall has become thin and membranous. Consequently the heart of an amphibian or any higher vertebrate appears to lie in the general peritoneal cavity, ensheathed in a thin smooth membrane—this latter being in reality the wall separating the pericardiac from the peritoneal cavity.

The kidney during larval life is a pronephros the number of whose functional tubules varies from about a dozen in the Apoda down to two in Urodeles. In the adult this is replaced by the opisthonephros. In the common Frog (*Rana*) a remarkable peculiarity is found in the adult inasmuch as the ciliated peritoneal funnels which stud the ventral surface of the kidney lose their connexion with the Malpighian bodies and come to open into the venous spaces (belonging to the posterior cardinal vein) lying between the tubules. Here we have an arrangement for returning coelomic fluid from the peritoneal cavity back into the blood—a phenomenon which we find again in the Mammalia though in them it is carried out in a different fashion by means of the lymphatic system.

The eggs are shed from the ovaries into the peritoneal cavity and pass thence by typical Müllerian ducts—usually long and convoluted and provided with glandular lining which secretes protective envelopes round the eggs in their passage.

The spermatozoa pass from the testis through vasa efferentia forming an irregular network into the Malpighian bodies or tubules of the opisthonephros and thence by the Wolffian duct to the cloaca and exterior. In different members of the Anura there occur interesting differences in the relations of the network of vasa efferentia to the testis and kidney, there being a tendency for the number of vasa efferentia to undergo reduction and for those that persist as well as the tubules with which they communicate to become shortened and widened so as to make the route of the spermatozoa from testis to Wolffian duct as simple and direct as possible. The final stage of this modification is seen in *Discoglossus*, in which the testis is continued into the Wolffian duct by a single direct channel which has emancipated itself entirely from the rest of the kidney. The whole type of modification is precisely like that seen in the Lung-fish, with the striking difference that in the Anura the persisting vasa efferentia are at the headward end of the kidney whereas in the Lung-fish they are at the hinder end.

A conspicuous feature in the dissection of a typical amphibian is due to the fact that the anterior portion of the ovary and testis degenerates and forms a **fatty body** in which there is stored up, in the form of fat, reserve nourishment to be drawn upon by the functional part of the gonad while it is preparing for the activity of the breeding season.

In the Amphibians there are to be found for the first time the compound organs known as **suprarenals**. These are slender organs of a bright yellow colour lying along the ventral (Anura) or mesial (Urodela) surface of the opisthonephros. The study of its development shows that the suprarenal is a complex formed by the fusion of two original separate elements. The first of these—known as the “medullary substance” in mammalian anatomy—is derived from the sympathetic ganglia and its substance is characterized by taking on a deep yellow or brown colour when treated with salts of chromic acid. The other element—the “cortical substance” of mammalian anatomy—is derived on the other hand from thickenings of the peritoneal epithelium between the two kidneys and is characterized by its cells containing numerous granules of fat-like material. Although the suprarenal complex makes its first appearance in the Amphibians it should be noted that its components are already recognizable as low down the scale as in Elasmobranchs although there they never become united together into a compound organ.

The suprarenal is an important ductless gland, the “medullary substance” making an important contribution to the internal medium in

the form of adrenalin, an excess of which causes smooth muscle fibres, such as those of the small arteries, to contract and in this way brings about an increase in the pressure of the blood by increasing the peripheral resistance to its flow.

The heart of the Amphibians may be illustrated by that of the Frog (*Rana*) which is commonly studied by the student of medicine both in the course of Zoology and that of Physiology.

The heart (Fig. 182) consists of the four usual segments: sinus venosus—a thin-walled somewhat triangular chamber situated dorsally, atrium—divided by a thin membranous partition into right and left auricles (Fig. 182, A, *r.a* and *l.a*), ventricle (*V*)—undivided, and conus arteriosus (*C*)—incompletely divided into systemic and pulmonary portions by a longitudinal spirally twisted septum (*s.c*).

The atrial portion of the heart has a thin wall strengthened by bundles of muscle fibres. In the left auricle these tend to take on a parallel arrangement, running longitudinally; in the right they interlace, running in all directions. More especially in the right auricle these muscles tend to become free from the auricular wall except at their ends, running straight across the cavity in the position of chords to the curvature of the wall, instead of following the curvature throughout their length. This modification in the position of the muscle bundles, a common phenomenon in the evolution of the heart, clearly renders them more effective. The interauricular septum (Fig. 182, A and C, *s.a*), a thin, usually complete, membrane traversed by slender muscle bundles and by two branches of the vagus nerve containing sympathetic fibres (see p. 417), occupies an oblique position—the degree of obliquity differing in different individuals—so that the right auricle extends ventrally well over towards the left side of the heart.

In a recess on the dorsal wall of the right auricle, a short distance from the septum, is situated the opening from the sinus venosus in the form of a transverse slit (*s.o*) guarded by the two sinu-auricular valves, anterior and posterior.

In the roof of the left auricle close to the attached edge of the septum and slightly headward of the sinus opening is the rounded opening of the pulmonary vein (*p.v*).

The cavities of both auricles are continued through the wide atrio-ventricular opening into the undivided cavity of the ventricle. The opening is guarded by four atrio-ventricular valves—two large (dorsal and ventral—Fig. 182, C, *a.v.D* and *a.v.V*) and two small (right and left—Fig. 182, C, *a.v.R* and *a.v.L*). Each valve is in the form of a thick

flap-like structure attached to the heart-wall along its headward edge. From the free edge of the valve and also from its outer surface pass

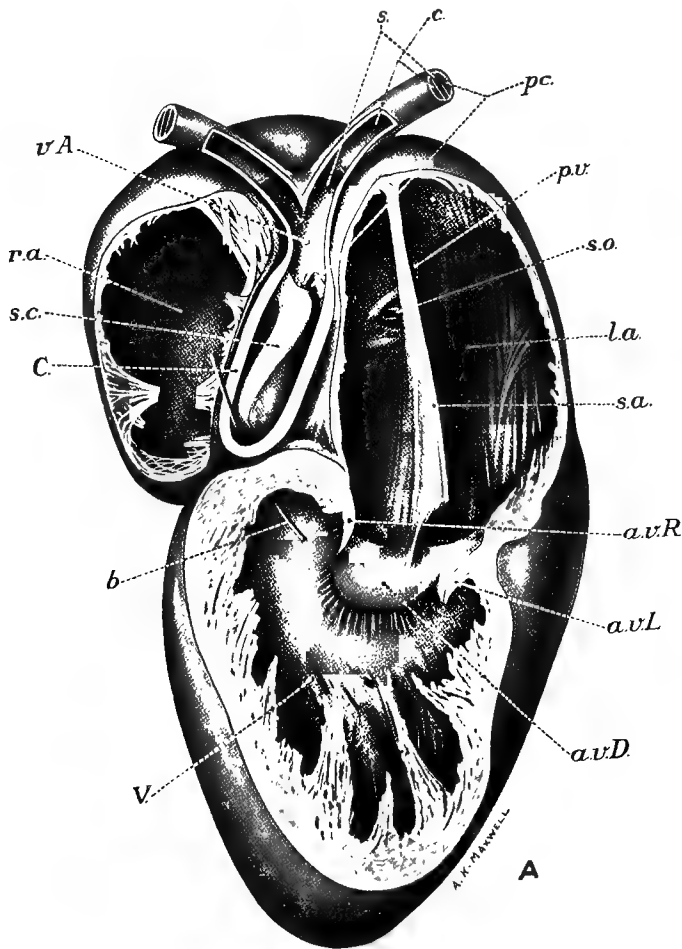

FIG. 182.

Heart of the Frog. A, General dissection from the ventral side. *a.v.D*, Dorsal atrio-ventricular valve; *a.v.L*, left ditto; *a.v.R*, right ditto; *b*, bristle passed from ventricle into conus; *C*, conus; *c*, carotid; *l.a.*, left auricle; *p.v.*, opening of pulmonary vein; *p.c.*, pulmo-cutaneous; *r.a.*, right auricle; *s.*, systemic cavity; *s.a.*, atrial septum; *s.c.*, septum of conus; *s.o.*, opening from sinus venosus; *V*, ventricle; *v.A.*, ventral aorta.

scattered cords of connective tissue to the ventricular wall which serve to limit the movement of the valve.

The atrial septum at its ventricular end terminates in a concave free edge which merges dorsally and ventrally into the substance of the large atrio-ventricular valve, its line of attachment dividing the free face of the valve into a larger right-hand and a smaller left-hand portion.

The wall of the ventricle shows a much greater thickness of muscle-bundles than that of the atrium. They run in all directions through the ventricular cavity, forming a thick open spongework which leaves only a comparatively small part of the cavity at its headward end unencroached upon. Towards the left this open space has on its headward side the wide atrio-ventricular opening, while on the extreme right is the much smaller opening leading into the conus (Fig. 182, A, b).

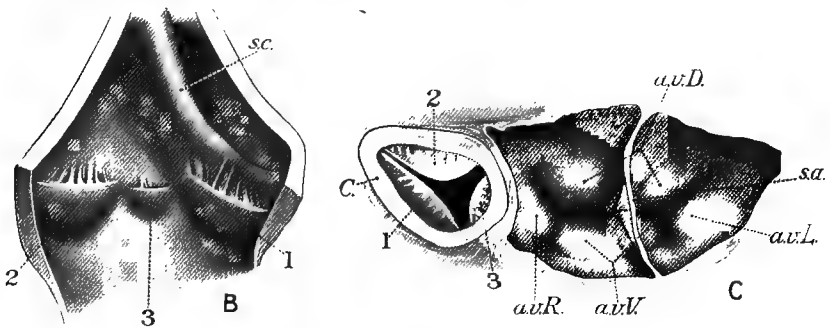

FIG. 182.

Heart of a Frog. B, Ventricular end of conus slit open to show the pocket-valves; C, atrio-ventricular valves (closed), etc., as seen in a heart cut transversely through the auricles and conus and viewed from the headward side. *a.v.D*, Dorsal atrio-ventricular valve; *a.v.L*, left ditto; *a.v.R*, right ditto; *a.v.V*, ventral ditto; C, conus; *s.a.*, atrial septum; *s.c.*, septum of conus; 1, 2, 3, pocket-valves at ventricular end of conus.

The conus arteriosus runs obliquely from its ventricular end in a headward direction and towards the left. Into the cavity of the conus projects the thick spiral ridge (Fig. 182, A and B, *s.c.*). This describes a right-handed spiral, its line of attachment to the conus wall commencing at its ventricular end by being ventral, and ending up at its headward end by being on the right.

The headward end of the spiral ridge is excavated to form a large pocket-valve, and there are two other smaller ones, making a circle of three pocket-valves at the headward end of the conus. Another circle of three pocket-valves guards the entrance to the conus at its ventricular end (Fig. 182, B and C, 1, 2 and 3).

The conus arteriosus is continued into the ventral aorta (*v.A*) which

is exceedingly short in the frog. Its cavity is divided into a ventral systemic and a dorsal pulmonary portion by a horizontal partition. This is continued at its cardiac end into the cavity of the large pocket-valve, and it lies in the same plane as the front end of the spiral septum seeing that the attachment of the latter to the conus wall is on the right side. If this description has been followed it will be realized that the dorsally placed pulmonary cavity of the ventral aorta is continuous with that part of the conus cavity which at its headward end is dorsal but at its cardiac end, owing to the spiral twist of the septum, on the right. Consequently we will call this part of the conus cavity "pulmonary" and the portion on the other side of the septum "systemic." This systemic cavity of the conus is continuous at its headward end with the systemic cavity of the ventral aorta.

At its headward end the ventral aorta becomes paired and each branch gives off in the adult frog three aortic arches—III (Fig. 182, A, c), IV (*s*) and VI (*pc*)—which are, however, firmly bound together for some distance so as to look in an ordinary dissection like a single vessel. An important detail is that arch VI is continuous with the dorsal or pulmonary cavity of the ventral aorta, while arches III and IV are continuous with the ventral or systemic cavity.

Having mastered the structural details of the heart it is possible to follow its mode of functioning. The two auricles become gradually distended with blood: the right auricle with venous blood received from the tissues by the sinus venosus, the left with arterial blood from the pulmonary vein. When the atrium has become fully distended its walls contract and the blood is forced through the atrio-ventricular opening into the ventricle—the venous blood from the right auricle tending to occupy the right side of the ventricle, the arterial blood from the left auricle tending to occupy the left side. The deep recesses in the spongy wall of the ventricle help to keep the two kinds of blood from mixing. When the ventricle has become distended with blood it too contracts. The first result is the closure of the atrio-ventricular opening, the valves being forced up into what in the diagram would be a position at right angles to the page—the connective tissue threads ("chordae tendineae") checking their movement when the opening is closed (Fig. 182, C). The ventricular cavity is now completely enclosed except as regards the opening into the conus, the blood rushes forwards through this, flattening the pocket-valves against the conus wall. It first fills the systemic part of the conus into which the opening leads, and distending the wall of the conus lifts it well clear of the edge of the spiral septum, so that the pulmonary cavity becomes also filled with

blood. This first blood to pass into the conus will clearly be that which was in the neighbourhood of its ventricular opening—the blood which was in the right part of the ventricle, i.e. venous blood. Of the three pairs of aortic arches the blood first passes into that in which the resistance is least—the sixth pair of arches leading to the comparatively short and simple circuit of vessels in the lungs. The lungs therefore receive venous blood.

The wall of the conus now itself contracts ; it is forced against the edge of the spiral septum and as a result the pulmonary cavity is isolated and the blood coming into the conus has now only two possible routes before it. Of these it again chooses that with the lowest resistance through the fourth (systemic) arches which lead to the greater part of the body. The third arches which form the roots of the carotid arteries offer the highest degree of resistance to the passage of blood, being provided with special blocking valves in their interior to ensure this. The result is that it is only the last of the blood from the ventricle—the arterial blood from its left side—that, after the resistance in the fourth arches reaches its maximum through their being filled with blood, passes into the carotid vessels and so to the brain. It follows then that just as the blood poorest in oxygen is sent to the lungs so that richest in oxygen is sent to the brain.

Comparing the heart of the frog with that of the lung-fish (*Lepidosiren*) it is to be noticed that it shows certain features which are found in the heart of the more highly developed tetrapods. (1) It has assumed the general form characteristic of the higher vertebrates. (2) The atrial septum is complete. (3) The conus arteriosus has become greatly shortened so as to straighten out the double fold present in the lung-fish and convert it into a regular spiral twist (as shown by the spiral course of the longitudinal ridge in its interior).

On the other hand the heart of the frog is further removed from that of the higher vertebrates than is that of *Lepidosiren* in the fact that the ventricle is undivided. Correlated with this is the quite peculiar method of directing the streams of arterial and venous blood to their respective destinations.

In the Amphibia in general the heart is constructed on the same plan as that of the frog—with various differences in detail. In the Urodela and Apoda the atrial septum is incomplete and in the same groups there is a well-marked tendency to reduction of the spiral septum of the conus. In the newts (*Triton*) it is found in some cases to have reverted to the condition of a longitudinal row of separate elements while in others it

has disappeared entirely. The latter is the case in various other Urodeles and also in the Apoda.

The arterial system is laid down on the same general plan as in the Fishes, there being a series of six aortic arches which undergo modifications of the same general type as will be described under the heading Reptilia.

The venous system is also laid down on the same general plan as in the lung-fish. There is a well-developed posterior vena cava which drains both the kidneys and which over the greater part of its extent has lost its original sheath of liver-substance.

The duct of Cuvier in the adult amphibian as in the adults of the higher vertebrates is termed the **anterior vena cava** (in Man the superior vena cava).

The primitively irregular lymphatic spaces have in the amphibians become more sharply defined. In the terrestrial Frogs and Toads large lymph cisterns are provided immediately beneath the skin. Others of the lymph spaces have become definite lymphatic vessels which serve to return the lymph to the blood-vessels. Where they open into the veins the lymphatic vessels may be provided with a rhythmically contractile muscular wall forming **lymph-hearts** which pump the lymph into the blood-stream.

The skeleton of the Amphibia is in great part bony. The notochord becomes replaced by a chain of vertebrae—ranging in number from over 250 in some of the Apoda down to seven—the smallest number known to occur in any vertebrate—in the African toad *Hymenochirus*. The vertebrae are at first cartilaginous—the cartilage *not*, however, invading the secondary sheath: the centra may be amphicoelous but more usually they fit together by rounded joint surfaces, the concave surface being behind (opisthocoelous—Salamanders) or in front (procoelous—Anura). The ribs in the Amphibia are very short.

There is a well-developed cartilaginous cranium strengthened by investing and replacing bones to which names are given corresponding with those used in the higher vertebrates. The skeleton of the visceral arches becomes in Tadpoles converted into an elaborate basket-work which acts, like the gill-rakers in Fish, to prevent food-particles from passing into the gill-cleft. In the adult, however, it becomes degenerate and simplified, forming a broad, flat, plate-like “hyoid apparatus” which supports the floor of the mouth.

Correlated with the mode of progression the base of attachment of the limb-skeleton to the trunk has been strengthened. In the case of the pectoral limb this has been brought about by the expansion of the

girdle. In the Urodeles the coracoid portions of the girdle are broad flat plates of cartilage which overlap one another. In most of the Anura the two halves of the shoulder girdle meet ventrally without overlapping and the line of their junction is prolonged forwards and backwards as a skeletal structure analogous with the sternum or breast-bone of higher vertebrates.

In the pelvic girdle the increased firmness is attained in different fashion through the tip of the iliac bone being attached to the tip of the transverse process of one or sometimes two **sacral** vertebrae. In the Anura, in correlation with their specialization for leaping and in order to bring the thrust of the hind-legs well forwards, the attachment of the pelvic girdle is relatively far forward, there being commonly only eight pre-sacral vertebrae and in *Hymenochirus* only five. In these Anura the portion of vertebral column behind the sacrum has degenerated and become converted into an unjointed rod of bone.

The brain of the amphibian with its large hemispheres and feebly developed cerebellum resembles that of the lung-fish. In the Amphibia we see for the first time a conspicuous **sympathetic** nerve-trunk—a longitudinal trunk lying just external to the dorsal aorta and aortic roots, bearing at intervals masses of ganglion cells (**sympathetic ganglia**) each connected with a spinal nerve by a little bridge of nerve-fibres (“*ramus communicans*”). The sympathetic nervous system is concerned with the control of the muscular coat of blood-vessels and alimentary canal. Thus in the case of the blood-vessels the muscular coat is kept in a state of tonic contraction so that the vessels are of medium calibre. By intensifying the control the calibre is reduced, by slacking it the calibre is increased. In this way the blood-supply to the various parts of the body is regulated.

A remarkable peculiarity exists in the otocyst of the Anura, the wall of the endolymphatic duct sprouting out and fusing with its fellow to form an irregular thin-walled sac full of otolithic particles and overlying the fourth ventricle. This sac continues to grow, spreading ventrally and also tailwards along the dorsal side of the spinal cord. Special outgrowths sprout out along the course of the spinal nerves and form the “*calcareous bodies*,” conspicuous chalky-white sacs which surround the spinal ganglia, the colour being due to the otolithic particles in their interior.

The Amphibia are of special interest from the extent to which they have been able to emancipate themselves from the ancestral watery medium and become terrestrial. They have never been able to do so completely however. A moist skin is essential to their life and

consequently they cannot stand an absolutely dry atmosphere. And they still possess a larval stage, fish-like in structure, which inhabits the water.¹ In the Urodele the larva presents a striking resemblance to a young *Lepidosiren* or *Protopterus* and is provided with external gills belonging to visceral arches III, IV and V. In the Anura the larva is a "Tadpole," the body from the anus forwards being greatly broadened. This broadening of the body is associated with the great length of the spirally coiled intestine.

Parallel to the edge of the mouth the tadpole normally possesses a number of fine-toothed **oral combs** which it uses for fraying out its food. Each tooth of the comb is built up of a series of hollow cones fitting into one another, each cone being a cornified cell. Each column of cones is constantly being added to at its base to make up for the loss of the apical cone which is shed when worn out. The teeth of the innermost row, along the margin of the mouth, are bigger and stronger than the others and instead of being spread apart they are in contact and fused together so as to form a horny beak.

¹ Various anurous amphibians have developed interesting arrangements whereby this particular difficulty—the need for an aquatic environment during early stages—has been more or less completely circumvented. A short account of these will be found in the writer's *Embryology*.

BOOK FOR FURTHER STUDY

Gadow. The Cambridge Natural History, Vol. VIII.

CHAPTER XII

AMNIOTA

REPTILES AND BIRDS

THE remaining groups of vertebrates have become purely terrestrial : they have completely emancipated themselves from the primitive aquatic environment. In rendering this possible a great part has been played by certain reproductive arrangements which constitute a common character linking them together into a group known as the AMNIOTA. The essential feature is that the time of hatching is delayed until those stages which in an amphibian would be passed through in the water have been completed in the seclusion of the egg. This has been rendered possible by a number of adaptive modifications :

- (1) The egg is enclosed in a hard or tough protective shell,
- (2) The egg contains an abundant supply of stored-up food-material or yolk which will serve for the nourishment of the embryo during the prolonged period before hatching,
- (3) The body of the developing embryo comes to be enclosed in a water-jacket known as the **amnion** which serves to protect its soft and delicate body from the dangers of knocks and jars, and
- (4) In order to accommodate the poisonous urinary secretion, which is no longer able to diffuse away into the surrounding medium, there takes place an immense hypertrophy of the allantois, and, incidentally, the vascular wall of this organ lying close under the egg-shell is able to meet the respiratory needs of the embryo.

The detailed description of these developmental features will be reserved for Chapter XIV.

REPTILIA

1. RHYNCOCEPHALIA—*Sphenodon*, the sole survivor of a comparatively archaic group of reptiles. It is restricted to certain islands in the Bay of Plenty, New Zealand.

2. LACERTILIA—Lizards, "Blind-worms."

3. OPHIDIA—Serpents.

4. CHELONIA—Tortoises, Turtles.

5. CROCODILIA—Crocodiles, Alligators.

For convenience there are grouped along with existing Reptiles a large number of extinct vertebrates. These reptile-like creatures reached their maximum development during the Jurassic period. Their remains show wonderful variety of form, and adaptation to special modes of progression—swimming (Ichthyosaurs, Plesiosaurs), bipedal running and leaping (Dinosaurs), flying (Pterosaurs). Some of them reached a gigantic size, such as *Diplodocus* which attained to over 80 feet in total length.

Our knowledge of these extinct creatures is practically limited to the bony skeleton. Of all the other important systems of organs we know nothing. We do not even know whether the covering of the body was dry and horny or soft and glandular, nor whether the early stages in development were of the highly specialized type characteristic of the Amniota. Consequently when we speak of them as extinct reptiles we use that term in a somewhat loose sense.

Restricting the term to existing reptiles we may say that they are the first subdivision of living vertebrates which have proved themselves entirely successful colonists of the dry land. They owe their success primarily (1) to the developmental adaptations already alluded to and (2) to the fact that the epidermis forms on its surface a thick dry horny layer which is highly effective in impeding evaporation from the body-surface.

The primitive form of the tetrapod body is departed from but little in the case of *Sphenodon*, the Crocodiles, and most of the Lizards (Fig. 177, B, p. 403). On the other hand in the Chelonians the trunk region has become squat and short, while in the Snakes it has become greatly lengthened and the limbs have completely disappeared. It is of great interest that a number of different types of Lizard are at the present time to be, so to speak, caught in the act of evolving in this same direction. Thus in the genus *Chalcides*, an obvious lizard common round the shores of the Mediterranean, the body is very elongated and the limbs very small, and in particular species the number of toes has been reduced from 5 to 3 while in one species they have disappeared entirely, the

whole limb being reduced to a tiny conical vestige. In still other lizards, such as the "Blind-worm" or "Slow-worm" (*Anguis*) and *Amphisbaena*, a lizard which has taken to burrowing like an earthworm, the limbs have disappeared entirely and the whole appearance has become snake-like or worm-like.

The skin of the reptile provides one of its most conspicuous characteristics. The dry horny epidermis, practically devoid of glands, is given flexibility by being subdivided up into scales—the highest degree of flexibility being attained by the scales overlapping like those of a teleostean fish (Lizards, Snakes). But it must be borne in mind that the scale of the reptile is in its nature essentially different from that of a fish—the former being a plate of cornified epidermis with a backing of tough dermis, while the latter is a plate of bone, the epidermis covering it being thin, soft and glandular. Horny claws are present on the digits.

The horny covering layer of the skin is shed from time to time. In the Rattlesnakes the portion ensheathing the tip of the tail remains for a time loosely attached to the body, a chain of these loose pieces constituting the "rattle." Various other poisonous snakes make their presence known by causing the tip of the tail to vibrate rapidly amongst dry grass or twigs, and the special arrangement of the Rattlesnake marks a further stage of evolution of this habit.

In connexion with the alimentary canal the first thing to be noticed is that in all terrestrial vertebrates there are special glands opening into the buccal cavity and serving by their fluid secretion to keep the mouth lining moist. In some of the reptiles the secretion has become highly poisonous. In one of the Lizards (*Heloderma*—of Mexico, New Mexico, and Arizona) this applies to a series of glands opening near the bases of the grooved teeth of the lower jaw. It is, however, amongst the snakes, particularly the Vipers (including the Puff Adder of Africa, the Adder of Europe and Asia, the Moccasin-Snake or Copper-head of the United States, the Fer-de-lance and *Vivora-de-la-Cruz* of South America, and the Rattlesnakes of North and South America) that the poison-apparatus reaches its highest development.

In these snakes there is on each side a functional poison-fang. Each of these is a much elongated, sharply pointed tooth with a deep groove along its anterior face. In the true Vipers this groove is closed in to form a canal except at its two ends, close to the base and close to the tip of the tooth respectively. The fang is mounted upon the maxillary bone and this, which bears no other functional teeth, is compact in form, being greatly shortened in an antero-posterior direction. It is suspended from the skull by a hinge-joint at its dorsal end, about which it can swing

freely parallel to the sagittal plane. Right at the other (hinder) end of the skull is another bone capable of a similar swinging movement. This is the long slender quadrate bone to the lower end of which articulates the lower jaw. A long bony strut, composed of pterygoid bone (behind) and transverse bone (in front), connects the lower portion of the quadrate with the lower part of the maxilla, with the result that these two bones are compelled to move in harmony like the two connecting pieces in a pair of parallel rulers. When the mouth is closed the quadrate swings back till nearly in line with the long axis of the head: the maxilla swings back similarly so that the poison-fang is laid back under the roof of the mouth. When, however, the mouth is opened the quadrate swings forward and the maxilla moves in harmony with it and the poison-fang is erected, ready to strike.

The base of the poison-fang is enclosed in a special sheath of soft tissue, the cavity of which opens freely into the opening at the base of the fang. Into this same sheath opens the duct of the poison-gland. This latter is the gland known as the parotid: it lies at the side of the head posteriorly and its presence has much to do with giving the broad appearance of the hind part of the head, contrasting with the comparatively narrow neck region just behind it, so characteristic of vipers. The poison-gland lies in close contact with the muscles used in biting and the contraction of these, pressing on the gland, squeezes out the poisonous secretion and causes it to flow forwards into the tooth.

The poison-fangs are peculiarly liable to injury and in correlation with this there exists behind each fang a series of young fangs to replace it. But it is not necessary that the fang should be broken or lost to induce the replacement. In the European Adder during active life the fangs are replaced at fairly regular intervals.

Although the broad head, sharply marked off from the neck, is conspicuous in the Vipers it is not so in all poisonous snakes and is therefore not to be trusted in forming a judgement as to whether or not an unknown snake is poisonous. The Cobras (*Naja*) of Asia and Africa, the Krait (*Bungarus*) of India, the Tiger Snake (*Notechis*) and the Death Adder (*Acanthophis*) of Australia, the Coral Snake (*Elaps*) of America, and the marine snakes, are well-known examples of poisonous snakes which have not got this distinctive feature.

As is the case with all the Amniota the visceral clefts, although they duly make their appearance in the embryo, never develop gills. The respiratory organs are lungs and these differ greatly in the degree of their development in different reptiles. In many of the small lizards they are no more complex than those of a frog—the lung lining growing

out merely into shallow sacculations. On the other hand in the larger reptiles, such as the Crocodiles and the large Turtles, the outgrowths of the lung lining are greatly increased in length and their walls project into secondary sacculations, the whole forming a thick respiratory sponge-work surrounding a comparatively narrow tubular central cavity or **intra-pulmonary bronchus**.

A point of general interest is that tetrapods in which the body has become much elongated in form commonly show the same asymmetry of the two lungs as occurs in the Crossopterygians or the young Lung-fish—the left lung being reduced in size. This is well shown by the various reptiles that have assumed a snake-like form. The asymmetry may be comparatively slight as in the Boa, or the left lung may disappear entirely as in the Adder. In the latter, as in various other snakes, a further modification has taken place—in that the hinder part of the right lung has become smooth and thin-walled and has lost its respiratory function.

In the Chameleons also parts of the lung-wall have lost their respiratory function, but here these parts of the lung take the form of pocket-like outgrowths which the Chameleon is able to blow up with air when alarmed. Such outgrowths of the lung are of much morphological interest for they foreshadow remarkable developments characteristic of the lung of Birds.

In Fish and Amphibians the lungs are filled by air being forced into them from the mouth. In Reptiles on the other hand we find for the first time “costal respiration” taking place, air being drawn into the lungs by movements of the ribs. In the Chelonians where this is impossible, the ribs being fixed in position, air is drawn in by the flattening of a curved sheet of muscle forming a floor underneath the lungs.

The allantoic bladder, in spite of its great size in the embryo, disappears as a rule during the development of the reptile, although in Chelonians and Lizards part of it persists as a functional urinary bladder in the adult.

As regards the coelomic organs the chief point to notice is that the nephridial organs have assumed the condition characteristic of the Amniota in general. The pronephros appears merely in the embryo as an inconspicuous vestige. The opisthonephros is differentiated into mesonephros and metanephros. The mesonephros functions as kidney during the developmental stages but in the adult its place as such is taken by the metanephros, and what remains of the mesonephros fulfils a purely sexual function. It lies in contact with the testis, forming the **epididymis**, and its tubules serve to convey the spermatozoa into the Wolffian duct or vas deferens.

In the heart of the reptiles the most interesting advance has to do

with the conus arteriosus. It will be recalled how in the headward portion of the conus of the lung-fish (p. 384) the cavity becomes divided into a dorsal pulmonary and a ventral systemic portion by the meeting and fusing of the right and left longitudinal ridges. In the reptile a similar subdivision of the cavity of the conus takes place in the embryo, but it affects the whole length of the conus and not merely its front end. Further the systemic cavity becomes also subdivided longitudinally into a right and a left cavity. The conus thus contains three cavities and, owing to the conus becoming shortened and having its flexure straightened out as in the Amphibia, these cavities twist round one another in a right-handed spiral—the pulmonary cavity starting at its cardiac end by being on the right side, and ending up at its headward end by being dorsal. In some reptiles, e.g. Chelonians, a further step is taken, the longitudinal septa becoming split so that the conus is now resolved into three distinct vessels, twisted round one another in a right-handed spiral and forming the roots of the main arteries.

During these changes in structure the conus also undergoes physiological change for it ceases to contract rhythmically, its striped muscle becoming replaced by smooth. The conus has in fact ceased to exist as a constituent chamber of the heart and has become incorporated into the arterial system.

The atrium is completely divided into right and left auricle in the reptiles, but the ventricle shows only the beginnings of a septum, except in the Crocodiles, where it is complete. Of the three cavities, or three vessels, which represent the conus two originate from the ventricle on the right side of the septum, namely the pulmonary and the left systemic, while on the other hand the right systemic arises on the left of the septum.

The arterial system is laid down in the embryo on the same general plan as in fishes but as development goes on there takes place a process of gradual modification by which the original arrangement becomes completely transformed. The general characters of this modification as it takes place in a typical reptile is illustrated in Fig. 183, in which the vessels shaded in the drawing are those present in the adult, while those shown merely in outline are portions of the embryonic arterial system that disappear in the course of development.

In the first place it has to be noted that the longitudinal subdivision of the cavity of the conus extends forwards into the hinder part of the ventral aorta, this also becoming resolved into three cavities or three separate vessels—pulmonary, left systemic and right systemic—continuous with those of the conus (*p*, *l.S*, *S*).

Of the aortic arches the ventral portions of VI persist as the right

and left pulmonary arteries (*r.p* and *l.p*) while the portion of conus and ventral aorta out of which they open forms the common pulmonary artery (*p*). The dorsal part of arch VI persists in some cases (Lizards and Chelonians) as a **duet of Botallus**, or a vestige of it may remain as a solid strand, but more usually it disappears entirely.

Arch V is greatly reduced in all amniotes, having either disappeared entirely from development or being at the most recognizable as a fleeting and transient vestige. A clue to the tendency of this arch to disappear is given by the lung-fish (p. 384), in which arches V and VI are seen both to originate from the dorsal (pulmonary) cavity of the ventral aorta. It is clear that the more blood passes into arch VI the less will be left for arch V, and consequently the advancing evolution of the lung and its taking off a greater proportion of the available blood will naturally be accompanied by a reduction of arch V.

Arch IV is the **systemic arch** which is responsible for the blood-supply to the hinder

part of the aortic root and through it to the dorsal aorta. That of the left side is continuous with the left systemic cavity of ventral aorta and conus (Fig. 183, *l.S*) and therefore like the pulmonary artery receives venous blood from the right side of the ventricle. That of the right side on the other hand receives arterial blood from the left side of the ventricle through the right or main systemic portion of ventral aorta and conus.

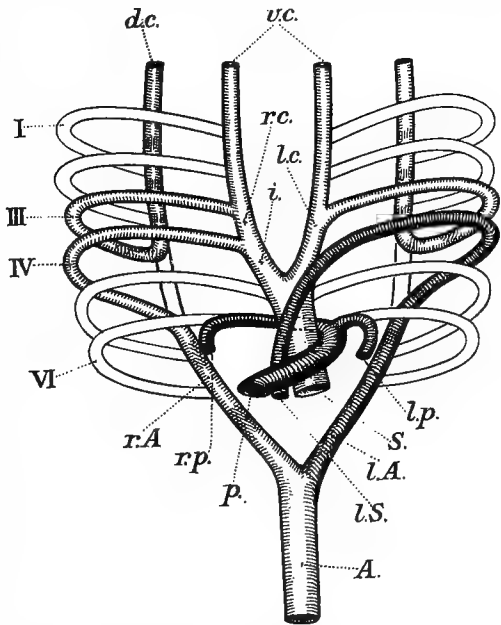

FIG. 183.

Diagram illustrating the arterial system of a reptile as seen from the ventral side. Those portions of the embryonic aortic arches which are no longer present in the adult are represented in outline. *A*, Dorsal aorta; *l.c*, left (common) carotid; *d.c*, dorsal carotid; *i*, innominate; *l.A*, left aortic root; *l.p*, left pulmonary; *l.S*, left systemic; *p*, pulmonary; *r.A*, right aortic root; *r.c*, right (common) carotid; *r.p*, right pulmonary; *S*, systemic; *v.c*, ventral carotids.

[The darkly shaded vessels receive venous blood from the right side of the ventricle.]

Arch III persists on both sides and supplies blood to the portion of aortic root lying in front of it (isolated except in most Lizards by the disappearance of the portion of aortic root lying between arches III and IV) and this in turn is continued forwards to supply the brain as the dorsal or internal carotid artery (Fig. 183, *d.c.*). As development goes on the arch as a rule becomes straightened out and in the adult there is nothing to show that the proximal portion of this artery was originally an aortic arch.

Arches II and I disappear entirely.

The anterior paired portions of the ventral aorta are continued forwards into the head as the ventral or external carotid arteries (*v.c.*). The portion immediately behind arch III becomes the common carotid artery (*r.c.* and *l.c.*) while the portion on the right side behind Arch IV becomes the innominate artery (*i.*).

The skeleton in the reptiles is well ossified in the adult. Its most striking peculiarities occur in the Chelonia where the trunk is enclosed in a rigid box composed of plates of dermal bone and attached to the deeper parts of the skeleton. The dome-like dorsal portion is the carapace, the flatter ventral portion the plastron. This bony box is overlaid by horny epidermal plates ("tortoise-shell") which do not, however, agree in form or number with the underlying plates of bone. These are not shed—as is the usual fate of the horny layer of the epidermis—but grow during the life of the animal both in area and in thickness. The ribs are firmly fixed to the inner surface of the carapace.

The brain in the reptiles is still small in size and simple in structure although it shows an advance on the condition in Amphibia. In the hemisphere region the pallium is thinner than in amphibians but shows greater complexity in its minute structure, distinctly foreshadowing the cortex of the mammalian brain. The most interesting feature occurring in the reptilian brain is seen in *Sphenodon* and in various lizards, in which the pineal body forms an eye, provided with a retina and a more or less distinctly developed lens. This pineal eye lies immediately beneath a transparent patch of skin, within a small hole in the roof of the skull (parietal foramen). As there are indications of eye-structure in the pineal organs of other vertebrates (Lampreys), and as various extinct amphibians possessed a very large parietal foramen presumably for the accommodation of a well-developed pineal eye, some zoologists believe that the pineal organ of vertebrates in general is to be regarded as representing the degenerate remains of an ancestral eye. Others, including the writer of this book, taking into account that many cases are known in the animal kingdom of nervous structures exposed to the

action of light developing visual organs secondarily, regard the visual character of the pineal organ as being a secondary acquirement evolved independently in the various vertebrates that possess it.

BIRDS

The Birds (AVES) are in many respects the most highly evolved of existing vertebrates. They seem clearly, as indicated both by the structure of modern birds and by the structure of the oldest known bird *Archaeopteryx* (Lithographic Stone of the Jurassic Period), to be descendants of reptilian ancestors which developed the power of flight.

The general form of body is characteristic: the large round head prolonged into a pointed face region, the relatively long flexible neck, the long fore-limbs with the degenerate hand serving merely as an attachment for feathers, the much modified hind-limbs with a greatly elongated ankle region, and the tail reduced to a small stump.

The act of flying, involving as it does great muscular exertion, necessarily implies intensely active metabolism and this in turn leads to such a production of heat that the temperature of the body is raised to a height considerably above that of its normal surroundings. Birds are therefore warm-blooded, or **homoiothermic**, to use a more precise term—the important point being not merely that the temperature is higher than that of the surrounding medium but that it remains approximately constant at one level, instead of rising and falling with the external temperature as is the case with the lower—**poikilothermic**—vertebrates.

With this physiological peculiarity is correlated a characteristic change in the covering of the body. The scales of the ancestral Reptile have become as it were frayed out to form fluffy **feathers** which, with the air entangled amongst them, form an admirable non-conducting coat and greatly impede the loss of heat from the body-surface.

A typical feather (Fig. 184, A) has a highly complicated structure. The central axis is distinguishable into (1) the hollow **quill** or calamus (*c*), embedded in a socket or follicle of the skin, perforated at its tip by a minute opening (inferior umbilicus) into which projects a papilla of the dermis provided with blood-vessels and nerves, and containing in its interior a series of little horny caps fitting one over the other, and (2) the **rachis** (*r*), white in colour and quadrangular in section. The rachis supports the vane or vexillum—a flattened expansion formed of numerous **barbs** (*b*), parallel and adherent to one another, and attached to the rachis at a high angle. Each barb carries two rows of **barbules** which spring from it very much as the barbs do from the rachis. The distal

row of barbules are provided with hooklets (hamuli) which hook over the proximal barbules belonging to the next barb, and it is this which causes the barbs to cohere together to form the flat vane. When these hamuli are not present the feather is downy—the individual barbs remaining loose. This condition is usually to be seen in the barbs nearest the quill (Fig. 184, A).

From near the base of the rachis there springs the after-shaft or hyporachis (*as*), like a small replica of the rachis and vexillum. This varies greatly in size and in the Ostrich or Emu is of practically the same size as the rachis and vane.

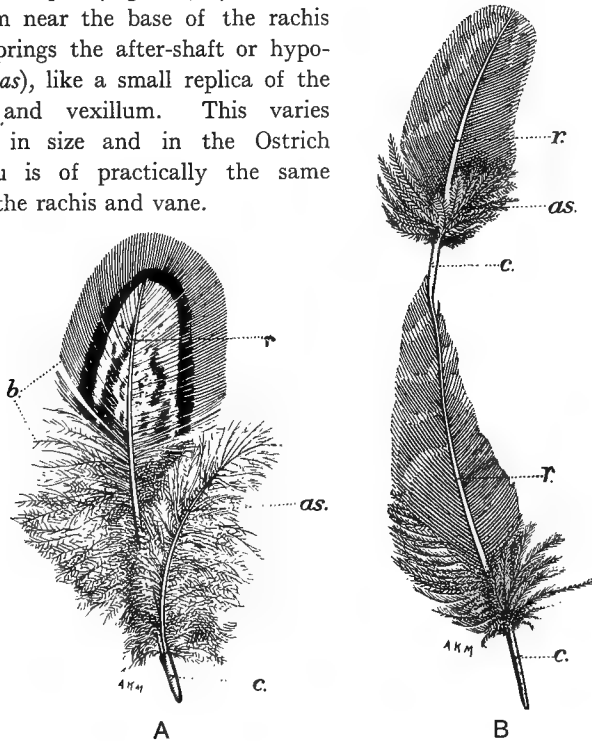

FIG. 184.

A, Contour feather from a fowl, seen from the inner side; B, abnormal feather from a Golden Pheasant in which the process of shedding at the preceding moult has not taken place. *as*, After-shaft; *b*, barbs; *c*, quill; *r*, rachis.

The feather in the early stages of its development resembles the rudiment of a reptilian scale but during subsequent stages undergoes complicated changes which need not be described. As development goes on it becomes sunk in its follicle and growth takes place at its inner end. The growth of the feather takes place in spurts at the periods of moulting. At this period the growing zone close to the tip of the quill becomes active, the feather rapidly increases in length, and the pre-

existing portion is pushed out of the follicle. As this happens it breaks off and is shed.

It follows that the successive "feathers" that develop from the same follicle at successive moults are as a matter of fact not separate individual feathers but merely successive portions of a single continuous structure. Fig. 184, B, illustrates an interesting abnormality in which two of these successive instalments of feather retain their continuity, the distal portion having failed to become detached at the preceding moult.

The first instalment of feather developed from each follicle differs from its successors in being a **down** feather, a short quill bearing a crown of barbs which are not arranged in one plane and are not coherent but free and fluffy. The coating of down-feathers is succeeded by the ordinary coats formed mainly of overlapping **contour** feathers like that described.

In particular regions of the body occur feathers more or less modified in character. Along the edge of the wing are the specially long and stiff flight feathers (remiges) divided into the primaries, attached to the hand region, and the secondaries, attached to the forearm. In these the posterior series of barbs are considerably longer than the anterior, so that the air pressure causes them to bend upwards during the downward beat of the wing so as to bring about a forward thrust to the body.

Another set of large stiff feathers are the tail-feathers or rectrices, most usually 12 in number, which play an important part in steering the bird and in checking its flight when alighting.

Types of feather more highly modified are the filoplumes, scattered about amongst the ordinary feathers, in which the vexillum is greatly reduced in size; and the bristles, frequently found at the base of the beak, or occupying the place of eyelashes, in which the vexillum has disappeared entirely.

Well-developed claws are present on the toes, but in the case of the wing the degeneration of the digits has been accompanied by the disappearance of claws. It is of evolutionary interest to note that the ancient and relatively primitive bird *Archaeopteryx* possessed well-developed claws on all three digits of its wing and that they turn up not unfrequently (to the number of 2 or 1) in various modern birds. In the curious South American bird, *Opisthocomus*, the young bird is able to clamber about quite actively by means of the two claws on its wing.

As is the case in Reptiles so also in the Birds the glands of the skin—so numerous in Fish and Amphibians—are greatly reduced in number. In a typical bird in fact the only well-developed gland of the outer skin

is the single or paired **preen-gland**—the secretion of which is used for oiling the feathers. In most birds this is situated on the dorsal surface near the root of the tail: in the ordinary fowl and its allies on the side of the head just behind the ear.

The oldest known fossil birds (*Archaeopteryx*—Jurassic, *Ichthyornis* and *Hesperornis*—Cretaceous) possessed well-developed sharp conical teeth, but in existing birds these have disappeared entirely, having been replaced functionally by the horny beak. Up to the present time no undoubted tooth vestiges have been found in bird embryos although such may very possibly await discovery in some of the more primitive birds.

In correlation with their intensely active metabolism Birds possess a very highly developed respiratory apparatus—the lungs attaining to the highest grade of evolution known in the animal kingdom. In the young developing bird there sprout out from the ventral wall of the lung pocket-like outgrowths comparable with those of Chameleons. In the bird, however, these outgrowths reach an immense size, becoming great **air-sacs** with very delicate membranous walls which insinuate themselves amongst the organs of the peritoneal cavity. The air-sacs are five in number on each side and are named according to their position in the body (1) cervical, (2) inter-clavicular (the right and left becoming fused together), (3) anterior thoracic, (4) posterior thoracic and (5) abdominal.

Functionally the air-sacs are not directly respiratory, their walls being non-vascular. They act as accessory organs to the respiratory process, constituting a kind of bellows by which air is forced in and out of the lung in the restricted physiological sense. The body-wall enclosing the peritoneal cavity of the bird is traversed by a characteristic arrangement of the skeleton. Dorsally is the vertebral column, its thoracic and abdominal portions being rendered rigid by its constituent vertebrae being fused together. Ventrally is the broad rigid sternum or breast-bone. Laterally sternum and vertebral column are connected by the highly-elastic >-shaped ribs with flat overlapping **uncinate processes**.

The bird is able by contracting the muscles of its body-wall to draw the sternum towards the vertebral column, bending the elastic ribs as it does so. This lessens the volume of the peritoneal cavity, compresses the air-sacs, and forces air from them outwards through the lung. When, on the other hand, the muscles are relaxed, the elasticity of the ribs forces the sternum in a direction away from the vertebral column, the peritoneal cavity recovers its volume, and air is drawn back into the air-sacs through the lung. The act of expiration is consequently in the

bird brought about by muscular contraction, that of inspiration simply by the passive elasticity of the skeleton.

The lung itself in the restricted sense undergoes during its development great complication in its minute structure. In all other vertebrates the respiratory surfaces of the lung are in the form of blindly ending pockets. In the bird on the other hand the originally blindly ending pockets become joined up by their tips to form continuous channels. In the fully developed lung these are very complicated, the main intrapulmonary bronchus giving off side branches, these in turn giving off numerous **parabronchi** arranged parallel to the surface of the lung, and the parabronchi communicating with an intricate network of exceedingly fine **air-capillaries** in the closest possible relation with the blood-capillaries—the two sets of capillaries with their very thin dividing walls constituting a quite unrivalled mechanism for respiratory exchange between the air and the blood. While the main fact is clear enough that the bellows-like arrangement of the air-sacs provides for the passage of air inwards and outwards through the cavities of the lung, it is not yet definitely worked out in detail by what arrangements the air-stream is deflected through the air-capillaries.

The lung of the bird, apart from the air-sacs, is of relatively small size and is moulded closely to the inner surface of the body-wall. Its connexion with the pharynx is by way of a long trachea which forks at its hinder end into the two bronchi. Both trachea and bronchi are strengthened by cartilaginous rings. At the pharyngeal end these are somewhat modified to form a larynx but it is eminently characteristic of the birds that the organ of voice is not the larynx but a special organ, the **syrix**. This is formed by modifications, differing in degree in different types of bird, of the tracheal tube in the region where it divides into the two bronchi. Parts of its wall are reduced to thin membranes, the tension of which can be varied by special muscles, and the voice is produced by these being thrown into vibration by the air-current.

The most conspicuous function of the air-sacs has already been dealt with but there is also an important accessory function. During the expansion of the air-sacs in the bird embryo their walls come at numerous points into contact with the bones of the skeleton and where this happens the bony tissue is absorbed and the air-sac wall burrows its way along the axis of the bone, taking the place of the marrow. In this way the bones of the bird are rendered **pneumatic** and the available amount of bony substance is used to the greatest advantage in the construction of large hollow, instead of small solid, bones. This fact that the bones of the skeleton are traversed by air-spaces in communication with the lung

explains how it is that a wounded bird with a broken bone projecting from its body can sometimes go on breathing when an attempt is made to suffocate it by compressing the mouth and nostrils.

The birds possess a very characteristic type of stomach. The oesophagus is highly glandular and somewhat dilated at its posterior end to form the **proventriculus**. This opens into the rounded stomach, which is also glandular but in which the secretion is of a quite peculiar kind, in that it spreads over the inner surface and hardens into a tough horny protective coat. The wall of the stomach is very thick and muscular and the organ acts as a gizzard for grinding up the food, the process being aided by stones which the bird swallows, while the inner surface is protected from injury by the horny secretion already mentioned.

The metanephros of the bird is elongated, closely fitted in between the transverse processes of the sacral vertebrae, and its secretion is noteworthy for the small proportion of water it contains. The excess of water appears in the bird to pass to the exterior mainly as vapour in the expired air from the lungs.

In the reproductive system the main feature is the asymmetry, the right ovary and oviduct being reduced and non-functional. This is probably correlated with the very great size of the bird's egg and its rigid shell, and the dangers that would arise from two such eggs passing to the exterior synchronously.

The heart shows complete division of the ventricle, the right ventricle being wrapped as it were round the left as may be seen in a cross-section. The conus undergoes the same division by a primary septum as in the reptile but there is no further subdivision of the systemic cavity. This latter feature is correlated with the fact that in the bird (Fig. 185) the left systemic aortic arch has disappeared, and no doubt this disappearance we may in turn correlate with the increasing perfection of the lung entailing a large and larger proportion of the available blood in the right ventricle being drawn off into the pulmonary artery (cf. Fig. 183).

The ventral or external carotids (Fig. 185, *v.c.*) are throughout the greater part of their length reduced to insignificant vestiges, the entire blood-supply to the head passing by way of the dorsal or internal carotids (*d.c.*). These arteries become approximated together immediately ventral to the vertebral column of the neck and in many birds they become completely fused into a single vessel. When this happens a further development may take place through the disappearance of the hinder, unfused portion of the artery either on the right (Grebe, Quails, Woodpeckers, ordinary perching birds) or on the left side (African Bustard) so that the blood for the head region is derived entirely from the left or the right side.

Birds, along with Chelonians and Crocodiles and a few mammals, are characterized by the blood-supply to the pectoral limb being provided by a **secondary subclavian** artery. The original or primary subclavian artery is a branch of the dorsal aorta or aortic root. In the animals just mentioned the blood-vessels in the limb rudiment establish a secondary connexion with the ventral end of the third (carotid) aortic arch, and this secondary channel usurps the place of the original channel of supply to the limb, forming the (secondary) root portion of the subclavian artery while the original root disappears.

In the venous system the main point to notice is the disappearance of the renal portal system which was so conspicuous in the lower vertebrates. Originally there is such a system in the bird also, but during the course of development the proportion of blood reaching the tubules by way of the renal portal becomes less and less as compared with that which comes direct from the dorsal aorta. The advantage of this is readily understandable when we bear in mind the superiority of the aortic blood both in composition (arterial) and in pressure.

Some of the peculiarities of the bird's skeleton have already been alluded to. The skeleton is very highly ossified. The flexibility of the neck is heightened by the peculiar saddle-shaped joint surfaces of the

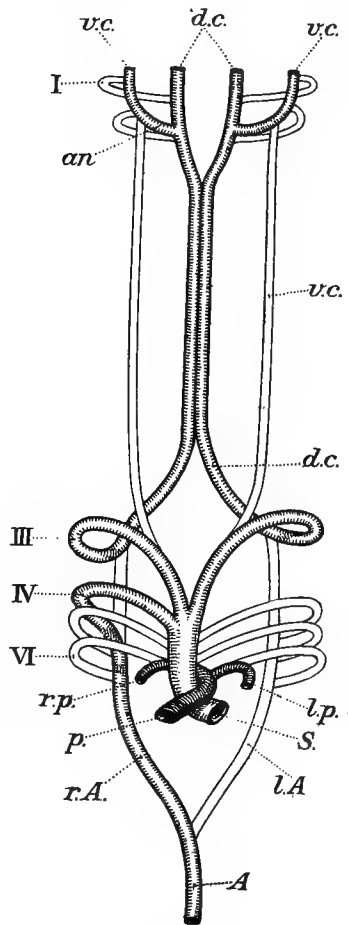

FIG. 185.

Diagram illustrating the arterial system of a bird as seen from the ventral side. Those parts of the primitive arterial system which are no longer present in the adult are drawn in outline. A, Dorsal aorta; an, anastomotic vessel; d.c, dorsal carotids; l.A, left aortic root; l.p, left pulmonary; p, pulmonary; r.A, right aortic root; r.p, right pulmonary; S, systemic; v.c. ventral carotid.

centra. At the other end of the vertebral column the tail region is reduced to a short stump, although

Archaeopteryx shows us that birds originally possessed long tails like those of lizards.

In the skull a conspicuous feature is the large rounded cranium, enclosing the brain and continued forwards into an elongated face region, its individual bones completely fused together in the adult. The face region is connected with the cranium dorsally by a thin flexible layer of bone, while on each side it is continued back as a chain of slender bones (maxilla, jugal, quadrato-jugal) to the ventral end of the movable quadrate. The bony palate or roof of the mouth is prolonged backwards into the elongated palatine and pterygoid bones—the latter at their hind ends also being attached to the ventral end of the quadrate. The special functional meaning of these arrangements is that they allow the upper jaw to be tilted upwards when the mouth is opened, the quadrate swinging forwards, and the palatine and pterygoid sliding forwards along the smooth prephenoid bone of the base of the cranium.

As might be anticipated from the peculiarly modified limbs, the limb-girdles show characteristic features. The pectoral girdle is based upon the very large sternum which projects ventrally as a prominent flat keel that serves for the origin of the large depressor muscles of the wing. In the running birds (Ostrich, Kiwi), where the wings have become reduced, the keel of the sternum also has disappeared. The girdle itself consists of a strong coracoid attached at its ventral end to the sternum, and a slender scapula or shoulder-blade. What correspond to clavicles meet ventrally and fuse to form the characteristic **furcula** or "merry-thought" bone. Scapula, coracoid and furcula at their meeting-point bound a rounded foramen through which, as over a pulley, there passes the tendon of the supra-coracoid muscle. This muscle, originating from the sternum and having the end of its tendon attached to the dorsal side of the humerus, plays an important part in raising the wing during flight.

In correlation with the very high grade of evolution reached by the birds both in their general structure and in their habits we find that they show a high stage of development of their nervous system. The eyes are of relatively enormous size and of the greatest complexity of structure. The otocysts are also highly developed and the lagena forms a curved cochlea devoted to the very acute sense of hearing. The cerebellum, in correlation with the complexity of movement, is large and complicated. The optic lobes are of great size—in association with the large size of the eyes. The hemispheres are large but the pallium—the portion which reaches its highest development in the mammals—is thin and comparatively inconspicuous.

From the evolutionary point of view Birds may be regarded as very highly developed flying reptiles. Their perfection as fliers dominates their whole structure. The first steps in the evolution of their power of flight are beyond our ken but the present writer regards it as probable that birds evolved out of aquatic reptiles, the fore-limbs becoming modified first for a kind of sub-aqueous flight similar to that of a Penguin. The modification of the scaly coat to form the fluffy plumage would be correlated with two separate functions (1) the protection of the body from cold and (2) the ensuring the most rapid return to the surface of the water after the pursuit of the fish which formed the creature's food. The initial stages of aerial flight would consist of flapping along the water's surface and the enlargement of the feathers of wings and tail would help this movement and at length make purely aerial flight possible.

CHAPTER XIII

MAMMALIA

SCHEME OF CLASSIFICATION

PROTOTHERIA, egg-laying mammals, restricted at the present day to Australia and New Guinea.

Ornithorhynchus, Echidna.

METATHERIA, mammals in which the retention of the young within the uterus is much less prolonged than in the ordinary mammals.

Opossums (N. and S. America), Australian Marsupials.

EUTHERIA, typical mammals.

Edentata (Ant-eaters, Sloths and Armadillos of the New World; Scaly Ant-eaters and Aard-vark of the Old World); Proboscidea (Elephant); Hyracoidea (Cony); Ungulata (Horse, Tapir, Rhinoceros, Hippopotamus, Pig, Camel, Deer, Giraffe, Ox, Sheep, Antelope); Sirenia (Manati and Duyong—highly specialized aquatic mammals); Cetacea (Whales); Carnivora (Cats, Dogs, Bears, Seals); Rodentia (Beaver, Rats, Cavies, Porcupine, Rabbit); Insectivora (Hedgehog, Mole, Shrew); Cheiroptera (Bats); Primates (Lemurs, Monkeys, Apes, Man).

Later portions of the medical curriculum will be devoted to intensive study of structure and function in Man—a typical example of the group Mammalia—and this chapter will consist merely of a few introductory remarks upon the general characteristics of the Mammalia.

While the Mammalia in the general plan of their organization have perhaps not reached such a high level of specialization as have the Birds there are three features in which they stand pre-eminent amongst vertebrates. The first of these is brain-power: in no other group of vertebrates is there anything like the high degree of psychical development found in the mammals; in no other group is there such skilled brain-

control and co-ordination of complex movement of the body. The second feature is the unrivalled height to which viviparity has evolved in the Mammalia, the early, relatively helpless, stages being passed within the body of the mother, the young individual forming as it were a constituent part of an adult individual with its full equipment for holding its own in the struggle for existence. The third feature is that within the limits formed by the general characteristics of the group there exists a remarkable variety of specialization for very different modes of life. These specializations are associated more especially with different types of movement—running (Ungulates), burrowing (Mole), climbing (Sloths, Monkeys), flying (Bats), swimming (Sirenia, Cetacea).

What may be termed the normal form of body of the mammal (Fig. 177, C, p. 403) does not differ widely from that of the lower Tetrapoda but an important advance is seen in that the mammal carries its body well clear of the ground instead of merely shuffling along its surface.

As in Reptiles and Birds the skin is provided with special developments of the horny layer, in this case **hair**. On the other hand the mammal differs from the Reptile or Bird and resembles rather the Amphibian in the fact that its skin is richly provided with epidermal glands.

A hair is a thin fibre-like extension of the horny layer of the epidermis. To give it firmness the underlying portion of the deep, active, growing, layer of the epidermis (Malpighian layer) becomes sunk down into the dermis so that the hair projects from a deep socket or follicle. The main function of the hair is to serve, with the air intervening between the individual hairs, as a non-conducting coat to lessen the loss of heat from the surface of the body. It serves also an important function in giving the mammal the colouration characteristic of the species. As a rule this is of such a kind as to render the animal inconspicuous when in its natural environment and under natural illumination from the sky. The pigmentation of the individual hairs is commonly such as to counteract the brighter illumination of the upper surface of the body and the less bright illumination of the lower surface, and in this way to flatten out the relief of the body when seen under normal illumination (Thayer's principle). The continuity of surface may also be broken up by strongly marked parti-colouring—as in the Zebra—while in the smaller mammals the fur helps to blur the sharpness of outline of the body.

The hairs, projecting out beyond the general surface of the body, form as it were outposts for the reception of tactile impressions and we find, as we should expect, that their bases are provided with sensory

nervous connexions. In particular cases the tactile function of hairs may become developed to a very high degree as may be demonstrated by the intolerable sensation produced by bringing a vibrating tuning fork into contact with one of the hairs of the moustache in man, or one of the "whiskers" of a cat.

The hairy coating shows various divergences from the normal. In aquatic mammals it tends to become reduced. In the whales it has disappeared altogether except for a few vestiges in the neighbourhood of the mouth, its heat-retaining function being taken over by the greatly developed layer of fat in the dermis (blubber) which possesses the important advantage over hair of having a lower specific gravity. In man the hairy coat has degenerated in correlation with the adoption of artificial heat-retaining coverings. In a few mammals some of the individual hairs become enormously enlarged so as to form defensive weapons (*Echidna*, Hedgehog, Porcupine).

The skin of the normal, terrestrial, mammal is provided with an abundance of epidermal glands and these are specialized in relation to three functions.

(1) In relation to the heat-retaining function each individual hair is kept dressed with the secretion of **sebaceous glands** opening on the inner surface of the hair-follicle.

(2) In relation to homoiothermy—the constancy of body temperature—certain glands are specialized for the purpose of counteracting to the needful extent the heat-retaining properties of the hair, according as the temperature gradient between the body and the external air varies in steepness—whether owing on the one hand to changing intensity of metabolism and therefore of heat-production within the body, or on the other to changes in external temperature. These glands are the **sweat-glands**: they produce a watery secretion which diffuses over the surface of the body and by its evaporation produces a cooling effect. In aquatic mammals the sweat-glands naturally tend to disappear, and the same has happened in a few terrestrial mammals. In the Dog for example they have disappeared for the most part except on the soles of the feet, and their cooling function has to be carried out by other means, by increasing the activity of breathing—"panting" causing a great increase in the amount of air drawn into the lungs and sent out again with a load of surplus heat.

(3) In relation to the function of nourishing the progeny certain epidermal glands (**mammary glands**) have become specialized for the secretion of milk. These are crowded together into paired masses (mammae) on the ventral surface of the body, the number of which

bears a rough relation to the number of young produced at one birth by the particular species of animal.

The epidermis of the mammal is underlaid by a dermis containing a great development of strong fibres running in all directions which give it the peculiar toughness characteristic of leather.

Such are the main features characteristic of the skin of mammals. There occur very many special developments of interest. Horny epidermal scales may cover the general surface of the body (*Manis*) or parts of it (tail of Rat). The claws may be modified as hoofs or nails. The bony horns of the Ruminants, such as the Cow, Sheep and Goat, are encased in a special horny sheath. The horn of the Rhinoceros, on the other hand, is horny and epidermal throughout. The transverse ridges across the palate grow out in one of the groups of Whales into flat plates of horn (whale-bone) which fray out at their edges into a fibrous mass that serves as a strainer to strain off from the sea-water the minute animals (plankton) upon which the whale subsists.

In the alimentary canal of the mammal one of the most conspicuous characteristics is the high degree of specialization of the teeth. It will be remembered that in the Dogfish there are arrangements for replacing the teeth as they become worn out, there being, so to say, numerous generations of teeth developed one after the other. Now it is highly characteristic of the mammal that a single set of teeth—termed the **permanent dentition**—remain functional during the greater part of the life of the individual. The immediately preceding generation is as a rule represented by a set of functional teeth present for a short period in the young animal and known as the **milk dentition**. The numerous other dentitions have been completely eliminated as functional organs, although in various mammals recognizable microscopic vestiges of a “pre-milk” and a “post-permanent” dentition have been found.

This reduction in the succession of the teeth has been accompanied by great advances in their individual structure. Whereas in the lower vertebrates the teeth are as a rule similar in form and structure (homodont) they are in the typical mammal specialized for different functions, those in front being flattened chisel-like cutting teeth (**incisors**), the next being conical pointed tearing teeth (**canines**), and the hinder ones being grinders. The more anteriorly placed grinders, usually distinguishable from the hinder ones by their simpler form and by the fact that each of them is preceded by a milk-grinder, are termed **pre-molars**, while the hinder ones, more complex in form and without milk predecessors, are termed **molars**.

The greatest complexity in form occurs in the grinder teeth. The crown of the tooth—the part projecting from the jaw—has its surface

raised to form knobs (bunodont, e.g. Pig), or ridges (lophodont, e.g. Rhinoceros), or crescentic elevations (selenodont, e.g. Sheep). As these projections are worn down by use the opposing surfaces of the upper and lower grinders are kept irregular by the differing resistance to wear afforded by the harder enamel and the softer dentine. Where the grinder-teeth are exposed to particularly great wear and tear owing to the harsh nature of the food (e.g. Horse, Elephant) the crown part of the tooth may be greatly exaggerated in relative size, the projecting ridges being of great depth and in this case they are protected from the danger of being broken off by being embedded in a matrix of bone (cement). Such teeth with specially deep crowns are termed **hypodont** to distinguish them from ordinary short-crowned (**brachyodont**) teeth.

As a rule the mammalian tooth reaches a definitive size after which it ceases to grow and its pulp cavity has its originally widely-open communication with the underlying tissue constricted to a comparatively small pore. Where, however, the tooth is subject to great wear and tear it is usually only at a late period that this shutting off of the pulp cavity takes place: it remains widely open for a prolonged period during which the tooth continues to grow in length (incisors of Rodents such as the Rabbit or Beaver or Rat).

The alimentary canal shows well-marked differentiation into distinct regions—buccal cavity, pharynx, oesophagus, stomach, and intestine. The gill pouches present in the embryo soon disappear except the first which remains as the Eustachian tube and the tympanic cavity. There is a well-developed larynx functioning as the organ of voice. The intra-pulmonary bronchus divides within the lung in a complicated tree-like manner, the ultimate twigs ending in minute chambers termed **infundibula**, the walls of which bulge out into **alveoli** lined with a rich network of capillary blood-vessels. The air-channels in the lung of the mammal thus end blindly as in other vertebrates with the exception of birds. The stomach is usually a simple dilatation of the alimentary canal but in some cases (Ruminants) it forms a series of chambers specialized for different functions. The most conspicuous peculiarity of the intestine is that its hinder portion (large intestine) is dilated and greatly increased in length to form a reservoir in which the faecal material accumulates. In all except the very lowest mammals the cloaca becomes split into a ventral portion continuous with the urinogenital sinus and a dorsal portion continuous with the rectum. The original cloacal opening thus comes to be represented by two distinct openings—urinogenital and anal—which are separated by a considerable space—the **perineum**. As in other terrestrial vertebrates there are well-developed salivary glands

opening into the mouth, the secretion of which serves to keep its lining moist as well as to play a preliminary part in the process of digestion.

It is characteristic of the mammal that the forwardly projecting portions of the splanchnocoele, containing the lungs and lying one on each side of the pericardiac chamber with the heart, become separated off as **pleural cavities**. Between the two pleural cavities and the intervening pericardiac cavity in front and the main peritoneal cavity behind there is interposed a characteristic transverse partition—the **diaphragm**. This is strongly convex on its headward side and concave on its tailward side: it is highly muscular—the fibres being arranged radially and passing at their inner ends into a sheet of tendon forming the central part of the diaphragm. The result of this structural arrangement is that contraction of the muscle-fibres of the diaphragm serves to flatten it, thus increasing the space upon its headward side and drawing air into the elastic lungs to occupy that space. Thus we have in the mammal the diaphragmatic method of inspiring air into the lungs in addition to the costal method.

The kidney of the mammal is a compact metanephros, so characteristic in form as to have given rise to the common adjective “kidney-shaped.” The ureters commonly open into the stump of the allantois which persists as a urinary bladder. Both ovaries and testes commonly become displaced in a tailward direction from their original position and the testes in most mammals pass, either temporarily during the breeding season or permanently, into a thin-walled pocket termed the scrotum. The urinogenital sinus is in the male prolonged as the urethra through the penis, but in the female the diminutive equivalent of this organ is, except in a few cases (e.g. rodents, mole), not traversed by the urethra.

The Müllerian duct of the mammal is differentiated into three portions, known respectively as Fallopian tube or oviduct in the restricted sense, uterus, and vagina. It is also usually the case in the mammal that the two Müllerian ducts show a tendency to undergo fusion in the mesial plane. In the Metatheria this approximation (Opossum) or actual fusion (other Marsupials) takes place at the level of the inner end of the vagina, but in the Eutheria the fusion involves the outer ends of the Müllerian ducts, extending inwards for a distance that differs in different mammals. Thus in the Rabbit the two vaginae are completely fused to form a single channel while the two uteri remain quite distinct; in the majority of mammals the two uteri also undergo fusion for a part of their length so as to form a “bicornuate uterus”; while in Man they fuse so completely as to form a pyriform uterus with the Fallopian tube opening into it on each side.

Both atrium and ventricle are in the mammal completely divided into right and left chambers. The conus and the cardiac end of the ventral aorta become split completely into two vessels (Fig. 186)—the pulmonary artery (*p*) and the systemic aorta (*S*) which course round one another in the customary spiral fashion. The modifications undergone

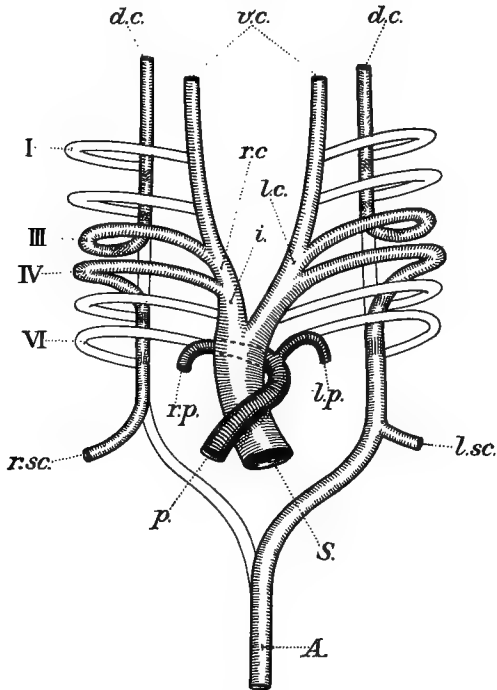

FIG. 186.

Diagram illustrating the arterial system of a mammal as seen from the ventral side. Portions of the embryonic arterial system which are no longer present in the adult are drawn in outline. *A*, Dorsal aorta; *d.c.*, dorsal (internal) carotid; *i.*, innominate; *l.c.*, left (common) carotid; *l.p.*, left pulmonary; *l.sc.*, left subclavian; *p.*, pulmonary; *r.c.*, right (common) carotid; *r.p.*, right pulmonary; *r.sc.*, right subclavian; *S*, systemic; *v.c.*, ventral (internal) carotid.

[NOTE.—The growth of the neck between arches III and IV brings about a wide separation of these arches in the adult, with a corresponding lengthening of the common carotid arteries.]

by the main arterial trunks of the embryo are on similar lines to those already described for the Reptilia but there is one striking peculiarity of the mammal, namely that the aortic root of the right side completely disappears from the point at which it gives off the subclavian artery (Fig. 186, *r.sc.*) backwards to the point at which it joins its fellow to form the unpaired dorsal aorta. It follows that in the mammal as in the

bird the unpaired dorsal aorta receives its blood-supply entirely from one side of the body: only in the mammal this is the left side whereas in the bird it is the right. A comparison of Figs. 186 and 185 will show however that the arrangement in the mammal is by no means a simple reversal, as regards right and left, of that in the bird. For in the bird the entire fourth aortic arch on the left side has disappeared together with the whole of the aortic root lying on the tailward side of that arch, while in the mammal the fourth arch of the right side and a large part of the right aortic root have been saved from disappearance by the presence of the ("primary") subclavian artery branching off from the aortic root. In the bird on the other hand the primary subclavian is no longer present having been replaced by a new ("secondary") subclavian which branches out from the region of the ventral end of Arch III.

Inspection of the two figures mentioned also teaches another interesting evolutionary lesson for it is seen that the arrangement in the bird is clearly a development of that seen in the typical reptile, brought about by the disappearance of the left systemic aorta, while the arrangement characteristic of the mammal seems equally clearly to have evolved out of a condition less advanced than that of the typical reptile, a condition in which the systemic portion of conus and ventral aorta had not yet become split longitudinally into a right and a left half.

In the descriptive anatomy of man and other mammals the whole extent of vessel from the left ventricle to the dorsal aorta is spoken of as the "arch of the aorta," and in a typical mammal this gives off in succession three branches—the innominate, the left common carotid and the left subclavian arteries—the relations of which to the primitive scheme are made clear by Fig. 186. In various members of the group Mammalia departures are made in detail from the typical arrangement. Thus the left subclavian may take its origin further forward and have a portion in common with the left common carotid so that one may speak of a left innominate artery in addition to the normal (right) innominate. Or the right subclavian may arise directly from the main systemic aorta so that there is no innominate artery but a pair of symmetrical common carotids. Again in such a case the two common carotids may for a considerable distance form an unpaired so-called primary carotid, and finally the two subclavian arteries may originate symmetrically from this unpaired trunk. All such departures from the more typical arrangement are of interest as illustrating the ways in which blood-vessels are liable to vary.

The venous system of the mammals is characterised by the well-developed posterior vena cava draining the blood from both kidneys, by

the elimination of a functional renal portal circulation even as a rule from early stages of development, and in many mammals (Edentates, Whales, Carnivores, Primates) by remarkable asymmetry which develops in the region of the anterior venae cavae. These latter vessels (ducts of Cuvier) show in such mammals the usual paired symmetrical condition during early stages. Later however a cross connexion arises between the right and left anterior cardinal veins a little in front of their opening into the ducts of Cuvier. This channel gradually enlarges so as to drain the whole of the blood from the left anterior cardinal vein into the corresponding vein of the right side close to its opening into the right duct of Cuvier. At the same time the left duct of Cuvier undergoes gradual reduction until eventually it is represented merely by a short stump (coronary sinus) into which open the veins of the wall of the heart.

A striking peculiarity of the mammals is that except in the embryo the red corpuscles are not complete cells but merely non-nucleated discs, circular and biconcave in form except in the Camels where they are elliptical.

The lymphatic system reaches a high stage of development in the mammal there being well-developed lymphatic vessels, provided with muscular walls like the blood-vessels and draining into the venous system by a longitudinally placed thoracic duct lying on the left side. The lymphatic vessels at particular points break up into a spongework (lymphatic glands) in which active multiplication of leucocytes takes place. Here and there in the course of the lymphatic vessels, as is also the case with veins, there are valves which ensure that the flow shall take place in the right direction but the lymphatic hearts which occur in the lower vertebrates have disappeared entirely in the mammals.

In the adult mammal the cartilaginous elements of the skeleton become almost entirely replaced by bone, the individual bones usually containing marrow in their interior,—either yellow and fatty or red in colour. It is in this last-mentioned red marrow that the chief formation of new erythrocytes in the adult mammal takes place.

Instead of being separated by smooth joint surfaces as is the rule in the lower tetrapods, the adjacent vertebral centra are in the mammal (except in rare cases, as in the neck of Ungulates) united together by **intervertebral discs** of tough fibrous tissue. The vertebral column shows marked differentiation into regions—cervical (usually 7 vertebrae), thoracic or dorsal, lumbar, sacral, and caudal. The ribs are long and well developed in the thoracic region, and the anterior ones reach the sternum which is divided up into a number of segments.

The cartilaginous cranium of the embryo becomes almost entirely replaced by bone : it is only in the neighbourhood of the external nares that cartilage persists to any considerable extent. The individual bones of the skull remain as a rule separated until late in life by irregular sutures. The general form of the skull resembles rather that of the Amphibian than that of the modern Reptile : in particular the cranial cavity extends right forward to the neighbourhood of the olfactory organ whereas in the typical modern reptiles and birds the two orbits are approximated close to the mesial plane, remaining separated by a thin **interorbital septum** into which the cranial cavity does not extend. Further, in correlation with the great development of the cerebral hemispheres, the cranial roof bulges upwards and the nasal region of the skull has the appearance of being rotated downwards in relation to the cranial cavity.

In *Echidna* and in the embryos of ordinary mammals the skull articulates with the first vertebra by a single transversely elongated joint surface (**occipital condyle**) but in the typical mammal the central part of this disappears so that in the adult there are two separate condyles one on each side.

A striking characteristic of the mammalian skull is afforded by the apparent absence of the quadrate—the large and conspicuous bone with which the lower jaw articulates in reptiles and birds. Its disappearance is associated with a remarkable change that has taken place in the auditory region. The columella—the bony strut which in the amphibians and reptiles transmits the vibrations of the tympanic membrane across the tympanic cavity to the contents of the auditory capsule—is replaced functionally in the mammal by a chain of three separate bones—**malleus**, **incus** and **stapes**. It is commonly held by vertebrate morphologists, on the ground mainly of their method of development in the embryo, that this chain of ossicles has not arisen in evolution as we should expect by a simple process of segmentation of the originally continuous columella but by the absorption into the tympanic cavity of two bones originally outside it, namely the quadrate (incus) and a small bone at the cranial end of the lower jaw in the reptiles—the articular (**malleus**). If this extraordinary theory is correct, and the great majority of morphologists accept it, it necessarily follows that the lower jaw has in the course of mammalian evolution developed a new articulation with the skull to replace its original articulation by way of the quadrate.

Another characteristic feature of the mammalian skull indicative of a high degree of adaptation to a warm-blooded terrestrial existence

is that the lining of the nose grows out to form complicated recesses between which remain thin partitions supported by bone and covered with sensory epithelium underlaid by a rich network of blood-vessels to warm the inspired air. In the dried skull the thin layers of bone supporting these partitions are seen as more or less complicated scrolls and spongeworks of bone known as **turbinals**—almost blocking up the nasal cavities in many of the mammals which breathe particularly cold air, e.g. polar bears and seals.

It is also characteristic of the mammal that the communication between the nose and the mouth becomes shunted backwards towards the glottis. This is brought about by the dorsal portion of the buccal cavity, into which open the posterior nares, becoming separated off by a floor—the “hard palate”—formed by the meeting of shelf-like bony ingrowths from the premaxillae, maxillae and palatine bones. It is of interest that a precisely similar displacement backwards of the communication between nose and mouth has taken place in the crocodiles amongst reptiles, though here it has been carried to a still further extent than in mammals.

In particular cases the limb skeleton of the mammal is greatly modified in correlation with the specialization of the limb for particular modes of progression: as in the simplified flipper of the whale, the wing of the bat with its immensely elongated slender digits for the support of the thin wing-membrane, or the foot of the horse with its solitary remaining toe—but on the whole the limb skeleton is characterized by a much lower degree of specialization than that of the bird. It has as a rule not departed very widely from the general plan of pentadactyle limb illustrated on page 404. It is characteristic of the typical mammals that the coracoid portion of the shoulder girdle has become reduced to an insignificant vestige, the “coracoid process,” which projects from the scapula. In those mammals in which it is necessary the function of the coracoid to prevent the scapula from being drawn down towards the sternum by muscular contraction is carried out by the clavicle or collar-bone.

The Brain of the mammal exhibits the same main regions as that of other vertebrates, There are various differences in detail. In correlation with the complicated co-ordinations of muscular contraction involved in the movements and balancing of the body the cerebellum is highly developed. Its superficial layers grow actively in area and become in consequence richly folded: its lateral portions are much enlarged (cerebellar hemispheres) and are connected together by a large ventrally

placed transverse commissure (**pons varolii**). In the mid-brain the optic lobes are small and each is divided into an anterior and a posterior portion (**corpora quadrigemina**).

But the great characteristic of the mammalian brain lies in the immense development of the cerebral hemispheres, in which is concentrated the general control of the subsidiary nerve-centres as well as the psychic activity. This high development of the hemispheres is indicated in the first place by their size and by the great area of their surface layers. Their size is such that they extend right back to the cerebellum, covering over the thalamencephalon and mesencephalon so that these parts of the brain are no longer visible in surface view. Where the size of the body is relatively great the surface layers of the pallium, growing rapidly within the confined space limited by the cranium, become thrown into characteristic folds or convolutions (gyri) separated by deep fissures or clefts (sulci). Thus while in an adult Opossum the hemisphere is smooth, in the Kangaroo it is convoluted. Or amongst the Primates the small Marmosets (*Hapale*) have smooth hemispheres while in the larger Primates they are convoluted.

The high degree of development of the mammalian hemisphere is still more apparent in the elaboration of its minute detail. The study of this shows that it is above all the pallium that is highly developed. The cortex in a lowly organized vertebrate like a lung-fish occupies only a restricted portion of the pallium and is concerned with the olfactory sense. In the mammal on the other hand its outer and inner (i.e. lateral and mesial) portions, now known respectively as the pyriform lobe and the hippocampus, are caused to recede from one another by an immense increase in the intervening portion which in the mammal comes to form by far the greater part of the cortex and is known as the **neopallium**. Whereas the cortex appears originally to have been associated entirely with the sense of smell the neopallium on the other hand is associated with the three other senses—vision, hearing, and touch—a special area of cortex being devoted to each of these. The tactile area is especially large and a particular portion of it shows a further specialization for the control of the movements of the body—each portion of the body having its own special part of this motor area of the cortex allocated to it. It will readily be understood how this localization of function is of the greatest importance in medicine, for it renders possible the exact location of a disturbing factor within the cortex—such as for example the presence of a tumour—by a study of its disturbing effect upon the movements of the particular parts of the body.

The cerebral cortex would appear also to be the seat of the psychic

activities of the mammal. This is shown in the case of man by the fact that the faculty of language, which is simply a particular aspect of thought, is located in definite regions of the cortex. The study of localized injury of the cortex through accident or disease has brought out the fact that a particular part of the auditory region is responsible for dealing with thought expressed in spoken words, and a part of the visual area with thought expressed in written or printed characters; while on the other hand definite motor areas are charged with the conversion of thought in the other direction into in the one case spoken language and in the other written.

Along with the specialization of various regions of the cortex in relation to special functions there has taken place *pari passu* a higher and higher perfection of nervous connexion between the various parts so that they remain linked together in the most intimate way as a functional whole. Thus the various parts of the hemisphere are linked together by countless association fibres: they are also linked with other subsidiary centres in the brain or spinal cord of whose activities they have assumed control: and they are linked up with their fellows on the opposite side of the brain by elaborate transverse commissures such as the immense corpus callosum which links together the neopallium of one hemisphere with that of the other.

CHAPTER XIV

ELEMENTS OF VERTEBRATE EMBRYOLOGY

THE Vertebrate like other animals begins its individual existence as a unicellular zygote formed by the coming together of two gametes, and this becomes gradually converted into the multicellular adult by a complicated series of developmental processes. These should be studied first in the case of *Amphioxus*, for it is in this animal that at least the earlier phases of development are to be found taking place in the simplest and least modified fashion.

The macrogamete or egg of *Amphioxus* is a relatively minute spherical cell about $\cdot 1$ mm. in diameter which is shed into the atrial cavity and passes thence through the atriopore to the exterior where syngamy takes place as a rule at once, myriads of microgametes having become disseminated through the sea-water synchronously with the emission of the eggs by the females. The act of syngamy is followed by segmentation. The zygote nucleus undergoes mitosis and a deep valley or furrow encircles the egg, gradually deepening and dividing the egg into two halves each of which rounds itself off into spherical form (Fig. 187, B and C). Careful study has shown that these two first blastomeres represent the right and left halves of the new individual.

Each blastomere now becomes subdivided by a precisely similar furrow or valley in a plane at right angles to that of the first—the result being that there are now four blastomeres (Fig. 187, D). These two first furrows are **meridional**: in other words they resemble in position the meridians of a terrestrial globe, passing through the upper or apical pole of the egg. There now appears a **latitudinal** furrow—corresponding in position to a parallel of latitude a little above the equator of a terrestrial globe—so that the egg consists now of four smaller blastomeres towards the apical pole, and four rather larger towards the opposite pole (Fig. 187, E). Other furrows make their appearance on the surface of the blastomeres and gradually deepening divide them into two, and as this process goes

on the egg becomes resolved into a large number of cells arranged in a single layer so as to form the wall of a spherical blastula (Fig. 187, I). It will be noticed that these cells are not absolutely uniform in size :

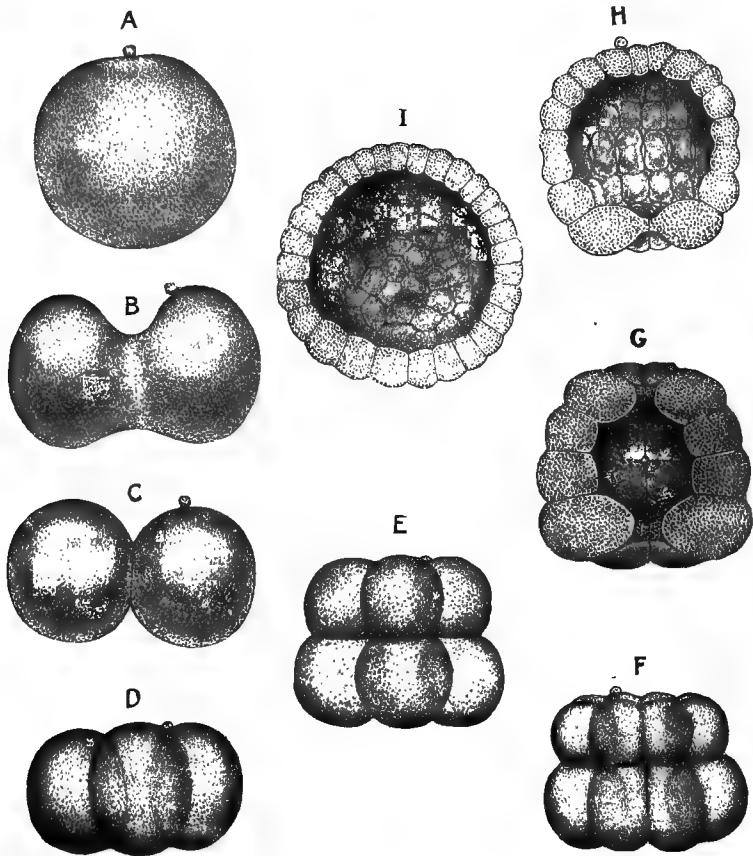

FIG. 187.

Segmentation of the egg of *Amphioxus*. (After Hatschek.) The second polar body is seen adhering to the surface of the egg in the neighbourhood of the apical pole.

those towards the apical pole are distinctly smaller than those towards the opposite pole. These latter possess cytoplasm of a more granular character—the granules consisting of minute particles of reserve food-material or yolk.

There now ensues the process of gastrulation by which the blastula becomes converted into a gastrula (Fig. 188). This process is initiated

by a flattening of the thick yolk portion of the blastula wall (A). The flattened portion gradually becomes invaginated, or in other words it curves inwards (B, C, D), to form a cup-shaped gastrula (E, F). The wide mouth of the gastrula becomes gradually reduced to a small opening—the **blastopore** (Fig. H)—the portion of the gastrular rim which later stages show to be anterior, or headward, in position gradually extending backwards so as to roof in the gastrular cavity. The blastopore marks the hinder end of what will be the dorsal surface of the larva.

At this stage there are present only the two primary layers of cells — ectoderm covering the outer surface and endoderm lining the gastrular cavity or archenteron. The mesoderm however now begins to make its appearance and the mode in which

it does so in *Amphioxus* is of great importance inasmuch as it has in all probability departed less from the primitive method than is the case with any other vertebrates and on that account gives us important clues to

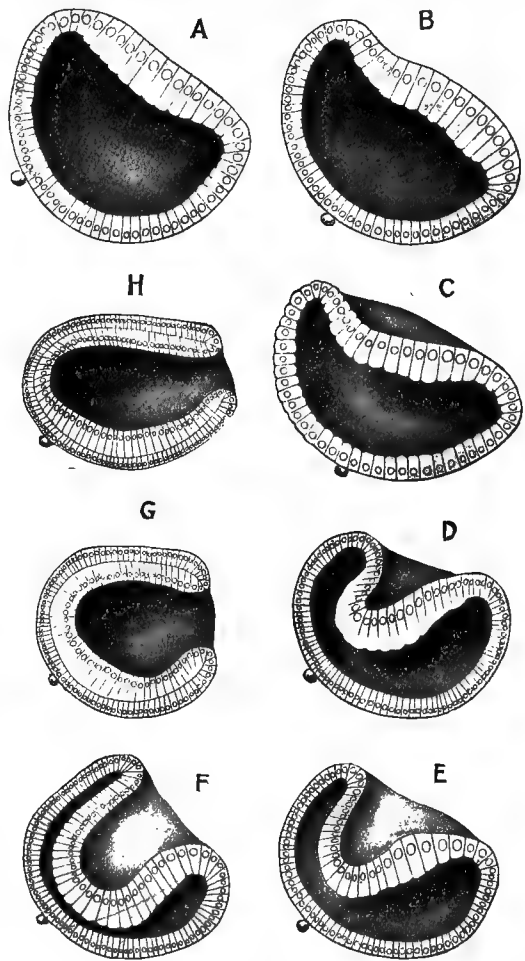

FIG. 188.

Gastrulation in *Amphioxus*. (From Graham Kerr's *Embryology*.) The second polar body is still adherent to the surface of the egg in the neighbourhood of the original apical pole. The individual figures are viewed from what is seen later on to be the left side of the *Amphioxus*, the dorsal side being above and the head end pointing towards the left side of the page.

the interpretation of the process as observed in other vertebrates. The most important point is that in *Amphioxus* during its early development the mesoderm passes through a stage in which it consists of pocket-like projections of the endoderm, arranged in a row along each side of the body (Fig. 189, B). As development proceeds these **enterocoelic pockets** as they are termed become gradually nipped off from the endoderm so

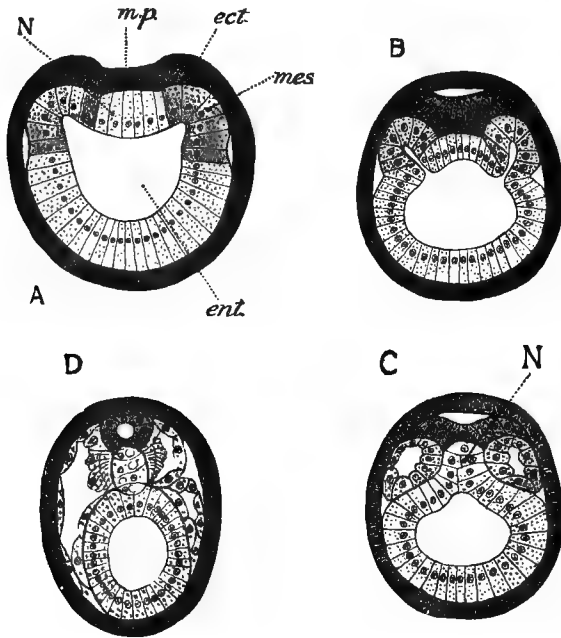

FIG. 189.

Transverse sections of young *Amphioxus* illustrating the origin of the mesoderm. (After Hatschek. *ect.*, Ectoderm; *ent.*, enteric cavity; *m.p.*, medullary plate; *mes.*, mesoderm; *N*, notochordal rudiment. The dark tone indicates ectoderm, the pale tone endoderm, and the medium tone mesoderm.

as to form closed compartments (Fig. 189, C). Each of these compartments is a mesoderm segment, and its cavity is a coelomic cavity.

By these phenomena in the development of *Amphioxus* we are taught two important lessons in the morphology of vertebrates, namely (1) that the coelome is enterocoelic in origin, its mesoderm wall being derived from part of the endoderm and (2) that the coelome is at an early stage in its development divided into successive compartments as is the case in an annelid worm.

Before proceeding further with the mesoderm we may note that the notochord originates from a longitudinal ridge of endoderm which separates off in the mid-dorsal line (Fig. 189, C), and that the central nervous system originates as usual from a thickening of the ectoderm (Fig. 189, A, *m.p*) which becomes converted into a neural tube by a process differing slightly in detail from that characteristic of other vertebrates (Fig. 189, B, C, D).

Each mesoderm segment becomes subdivided (Fig. 189, D, right side of fig.) into a ventral portion (lateral mesoderm) and a dorsal portion (myotome). Of these the former gives rise to the lining of the splanchnocoel, the cavities of successive segments opening into one another by the disappearance of the intervening walls. By extension downwards to the mid-ventral line the splanchnocoel becomes eventually continuous across the mesial plane ventral to the alimentary canal.

The inner wall of the myotome becomes much thickened and is eventually converted into a thick mass of longitudinally-running muscle fibres which retains the name myotome in the adult. In this process the coelomic cavity of the myotome becomes completely obliterated. Unlike what happens in the case of the lateral mesoderm the myotomes retain their individuality so that even in the adult the longitudinal muscles consist of distinct blocks one behind the other. Originally the myotomes lie completely dorsal to the lateral mesoderm but as development proceeds they extend down towards the mid-ventral line, insinuating themselves between the lateral mesoderm and the outer skin and so muscularizing the more ventral parts of the body-wall.

The more typical vertebrates are distinguished from *Amphioxus* by the fact that the egg contains a much greater amount of yolk and is consequently of much greater size. This yolk is so much dead inert material which tends to clog and obstruct the living activities of the cytoplasm. Consisting of greatly condensed food-material it is of relatively high specific gravity and tends to gravitate towards the lower or abapical pole of the egg: consequently we find that its interference with the normal processes of development is least in the neighbourhood of the apical pole and greatest towards the opposite pole, where its interference is more marked in accordance with the greater proportion it bears to the living cytoplasm in which it is embedded.

The effects produced upon the early stages of development by an increased proportion of yolk in the abapical portion of the egg are well illustrated by the three ganoid eggs shown in Fig. 190. In the Sturgeons (Fig. 190, A) the egg measures from 2 mm. to 2.8 mm. in diameter. The cytoplasm in the neighbourhood of the apical pole has disseminated

through it fine granules of yolk while at increasing distances from the apical pole the yolk becomes more coarsely granular and also more abundant, the intervening cytoplasm becoming more and more sparse. The delaying effect of the preponderating amount of yolk in the abapical portion of the egg finds expression in a prolonging of the intervals between successive divisions. The result is that the blastomeres of the abapical region of the egg divide more slowly and are therefore of markedly larger size than those of the apical region. The segmentation of the egg in such a case is said to be **unequal**.

In the case of *Amia* (Fig. 190, B) the proportion of yolk in the abapical portion of the egg preponderates still more, and the rapidity of segmentation is still more delayed, the meridional furrows that make

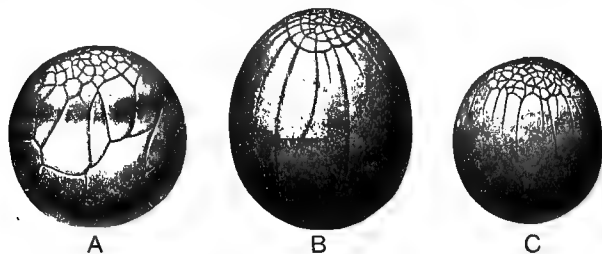

FIG. 190.

Ganoid eggs in course of segmentation. A, *Acipenser*; B, *Amia*; C, *Lepidosteus*.
(After Bashford Dean, Eycleshymer, and Whitman.)

their appearance at the apical pole spreading downwards with extreme sluggishness.

Finally in *Lepidosteus* (Fig. 190, C) the proportion of cytoplasm to yolk in the abapical hemisphere is so reduced as to render segmentation impossible. The furrows spreading downwards from the apical pole never extend much beyond the equator, and all the abapical portion of the egg remains unsegmented—a mass of yolk with only the sparsest remnants of cytoplasm between its granules.

In *Lepidosteus* therefore the process of segmentation is incomplete, or **meroblastic** as it is termed technically, in contradistinction to the complete or **holoblastic** segmentation exemplified by the other types that have been mentioned.

The process of segmentation results in a stage corresponding to the blastula stage of *Amphioxus* but peculiarities in the segmentation process bring about peculiarities in the blastula and these in turn bring about peculiarities in the process of gastrulation. In the egg with markedly unequal segmentation the part corresponding to the large-celled portion

of the blastula, which in *Amphioxus* becomes invaginated to form the endoderm, is enormously increased in thickness and it is physically impossible for it to be invaginated within the relatively minute small-celled portion of the blastula. Consequently we find with increasing proportion of yolk in the abapical region of the egg that the process of invagination becomes less and less conspicuous, its place being taken by a greater and greater activity in the process of overgrowth by the headward portion of the gastrular rim or lip. In the more heavily yolked eggs still another process becomes apparent namely **delamination**, the small-celled portion of the egg's surface gradually extending by the addition to it of small cells split off from the large yolky cells of the abapical region. The result of these various processes acting together is that the egg with unequal segmentation eventually has its large-celled portion (endoderm) completely enclosed within a covering of small cells (ectoderm) just as is the case in the completed gastrula of *Amphioxus*.

In the various groups of lower vertebrates we find illustrated in varying degrees these modifications of the processes of segmentation and gastrulation brought about by the presence of yolk. In *Amphioxus* as already indicated these modifications are seen at their minimum. A series such as *Polypterus*, a Lamprey, a Newt (*Triton*) or Frog (*Rana*), a Lepidosiren, shows increasing degrees of this modification. In the large egg of the Gymnophiona the segmentation of the abapical part of the egg is delayed to such an extent that the early stages of segmentation give the impression of a meroblastic egg. In the Elasmobranchs the egg is still larger and richer in yolk and we find a typical meroblastic condition. In the Teleosts, in correlation probably with the great wastage of their eggs, the eggs have become greatly increased in number and correspondingly decreased in size and therefore in yolk-content. However, the proportion of yolk to living cytoplasm is unaffected and consequently the teleostean egg retains the typical meroblastic character.

The special advantage of a store of yolk in the egg is that it enables the young individual to live for a more or less prolonged period upon its capital, so to say, and thus postpone the period when it has to enter into the active struggle for food and for existence. It is able to pass through in seclusion and comparative safety that period of its life that would otherwise be passed as a larva fending for itself. In such a case as that of *Lepidosiren* (p. 389) the larval stages are passed through in conditions which do not depart markedly from the normal and in which all the living activities of the young animal are carried on in normal fashion except that it is free from the necessity of obtaining food. In such a case as that of *Scyllium* or a Skate (*Raja*) on the other hand the seclusion

from the outer world is much more complete, the young animal being imprisoned within an egg shell, and in such cases the development becomes modified—the larval characteristics tending to disappear while features adaptive to an embryonic condition make their appearance.

It is in the Tetrapoda that we find, correlated with their assumption of a land existence, the most interesting modifications of the developmental process. The Amphibia as a group have not succeeded in emancipating themselves entirely from the ancestral aquatic environment. They as a rule still require to pass through a fish-like larval stage in the water.¹ But the Reptiles, Birds and Mammals have succeeded in becoming permanent denizens of the land. The developmental arrangements which have played a main part in enabling them to do this may best be illustrated by running over the main features in the development of a typical Bird such as an ordinary fowl. It is easy to obtain eggs that have been incubated for a definite number of hours and to examine their contents by opening them in normal saline solution heated to about blood temperature.

The macrogamete or egg in the strict sense is the yellow or “yolk” of everyday language. It is a gigantic spherical cell packed with reserve food-material or yolk, its superficial layer condensed to form a thin cuticle—the **vitelline membrane**. The living cytoplasm through the greater part of the egg is sparse to vanishing point but at the upper or apical pole there remains a little cap of cytoplasm—the **germinal disc**—which shows up distinctly by its white colour against the deep yellow of the rest of the egg. In the germinal disc lies the nucleus.

When shed from the ovary the egg is sucked into the trumpet-like coelomic end of the oviduct within which, if spermatozoa have been received from the male, it is fertilized. The egg proceeds down the oviduct, propelled by the contraction of its muscular walls. As it passes onwards it becomes enwrapped in clear jelly-like secretion—the **albumen** or “white” (Fig. 191, *alb*)—secreted by the oviducal lining and taking a characteristic shape—the pressure of the oviducal wall as it forces the egg onward giving the mass of albumen a more or less pronounced pointed or conical form, while on the other side of the egg the albumen bulging into the relaxed portion of the oviduct takes on a rounded form. The broad end of the hen’s “egg” is then the end which was directed

¹ A sketch of various interesting adaptive arrangements which have tended to lessen the dependence of various species of Amphibia upon the presence of water during early stages of their development will be found in *Lectures on Heredity and Sex*, by Bower, Graham Kerr, and Agar, or in the present writer’s *Embryology*.

towards the external opening in its passage down the oviduct. Along the long axis of the mass of albumen—from the vitelline membrane to each pole—there passes a denser less transparent strand of albumen known as the **chalaza** (Fig. 191, *ch*). The chalazae represent early formed portions of the albumen which preceded and followed after the egg in its passage along the oviduct. During this passage the egg rotates slowly on itself and the inner ends of the chalazae being attached to the vitelline membrane these structures are given a characteristic twist in opposite directions. The chalazae serve to keep the egg in the midst of the albumen while allowing it to rotate freely about the long axis of the mass of albumen. As the germinal disc is in a position which is practically equatorial in relation to this axis, or in other words it is as far as possible from this axis, and as further the cytoplasm forming it is of less specific gravity than the dense yolk, it follows that the germinal disc always comes to be uppermost if the egg in its albumen is rolled over, and is hence during incubation always next the warm body of the hen.

After the egg has traversed the albumen-forming region of the oviduct it receives a thin layer of a different type of secretion which forms a thin tough fibrous membrane—the

shell-membrane (Fig. 191, *s.m.*)—and finally on the surface of this is deposited a layer of calcium carbonate which hardens to form the porous **egg shell**. At the broad end of the “egg” the shell-membrane splits into two layers and as the albumen shrinks in volume during the course of development these two layers separate forming the **air space** (Fig. 191, *a.s.*) in which air, diffused in through the pores of the shell, accumulates in preparation for the young chick taking its first breath into its lungs.

In an egg kept under ordinary conditions a similar accumulation of air is brought about by the shrinkage of the white due to evaporation and hence the housewife’s dislike to an egg which by an active tilting up of its blunt end when submerged in water shows that its air-space is large.

As might be expected the segmentation is meroblastic, confined to the protoplasm of the germinal disc. The details of this process, which takes place as the egg passes down the oviduct, need not be gone into

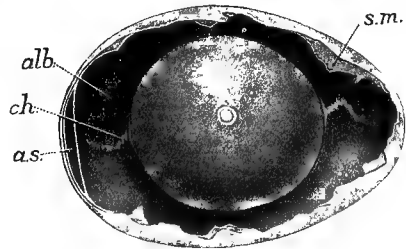

FIG. 191.

Egg of the Fowl, which has been laid without being fertilized. *a.s.*, air-space; *alb*, albumen; *ch*, chalaza; *s.m.*, shell membrane. In the centre—at the apical pole—is seen the germinal disc with the “Nucleus of Pander”—a mass of white yolk—showing through it.

but the result of it is that the germinal disc is converted into a mass of small cells—the **blastoderm**—which gradually increases in area so as to spread over the surface of the yolk. The first obvious signs of differentiation make their appearance towards the end of the first day of incubation when the central portion of the blastoderm (the **pellucid area**) becomes marked off by its translucency from the surrounding **opaque area**. The pellucid area, at first circular, becomes shaped like the outline of a pear and along the axis of this towards the narrow end runs a dim streak marked by a narrow groove along its centre—the **primitive streak** and the **primitive groove** respectively. The study of microscopic sections of this stage shows that the blastoderm consists in its central portion of two distinct layers of cells. Of these the outer, consisting of columnar cells closely fitted together, is the ectoderm, while the inner gives rise in great part to endoderm. The primitive streak is seen to be a region of active proliferation of the ectoderm. Active cell-division is taking place and the cells so arising spread outwards on each side between the two primary layers as a sheet of mesoderm. In certain parts the primitive streak shows complete cellular continuity with the endoderm as well as with the ectoderm and the study of the blastoderm of Reptiles gives a clue to the meaning of this for there are indications that the primitive streak marks the position of the opening of the gastrula which in the vertebrates has taken on a long slit-like form and then become obliterated by fusion of its lips.¹

Towards the end of the first day of incubation the ectoderm of the pellucid area becomes raised up into a crease or fold in the form of a long \cap , the open end of the \cap embracing the front end of the primitive streak. This fold is commonly spoken of in the plural as the medullary folds although the two folds are really quite continuous in front. The study of transverse sections shows that the folds mark the edge of the thickened area of ectoderm constituting the medullary plate—the first rudiment of the central nervous system. As development proceeds the medullary folds become more prominent and then arch inwards towards one another and meet and fuse so that the medullary groove lying between them becomes closed in to form the neural tube.

In an egg opened at about the middle of the second day of incubation (Fig. 192) the neural tube which has meanwhile increased considerably in length is seen to be closed in except in its hinder portion. Further its anterior portion has become distinctly dilated to form the rudiment of the brain, the hinder more slender portion giving rise to the spinal

¹ For discussion of this interesting theory see the present writer's *Embryology*, p. 493.

cord. The main regions of the brain are beginning to be marked off and in many embryos two distinct constrictions mark off thalamencephalon, mesencephalon and rhombencephalon. The brain as a whole has a

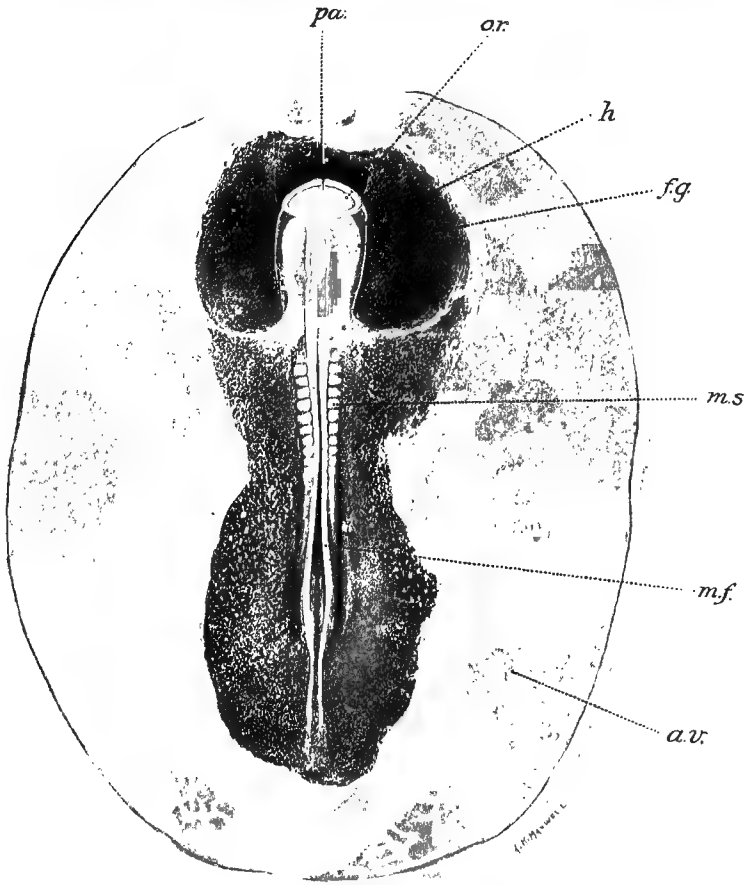

FIG. 192.

Blastoderm with Fowl embryo with about 10 or 11 mesoderm segments. *a.v.*, Vascular area; *f.g.*, fore-gut; *h*, head; *m.f.*, medullary fold; *m.s.*, mesoderm segment; *o.r.*, optic rudiment; *pa*, proamnion—a part of the blastoderm into which the mesoderm has not yet spread.

characteristic hammer shape, the wall of the thalamencephalon projecting laterally on each side to form the optic rudiment (Fig. 192, *o.r.*).

Important changes have taken place in the mesoderm. The originally single sheet of mesoderm has, except towards its outer boundary and in

the region adjacent to the neural tube, split into two layers separated by a space containing fluid. This space is the coelome (Fig. 193, *splc*). The outer or **somatic** layer of the mesoderm is applied closely to the ectoderm to form with it the body wall or **somatopleure** (Fig. 193, *som*) while the inner or **splanchnic** layer is applied to the endoderm, forming with it the primitive gut wall or **splanchnopleure** (*spl*). The mesoderm adjacent to the neural tube is much bulkier than it is elsewhere, and this portion undergoes a process of segmentation into successive blocks lying one behind the other—the embryonic myotomes (Fig. 193, *my*). These increase in number, new myotomes being added on at the hinder end of the series.

The portion of the embryo containing the brain, i.e. what will become the head region, bulges well above the general surface and is marked

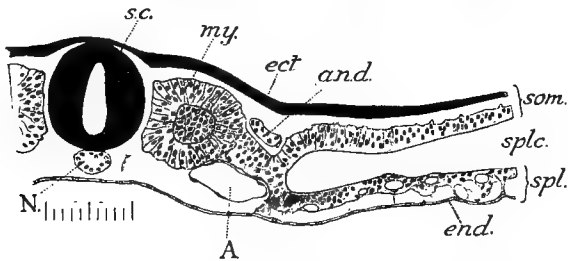

FIG. 193.

Transverse section through Fowl embryo of the second day (15 myotomes). A, Paired dorsal aorta; *a.n.d.*, archinephric duct; *ect*, ectoderm; *end.*, endoderm; *my*, myotome; N, notochord; *s.c.*, spinal cord; *som*, somatopleure; *spl*, splanchnopleure; *splc*, splanchnocoelome.

off by the blastoderm being tucked in underneath it in front and at the sides. Into this head rudiment there projects forwards a wide tube of endoderm (Fig. 192, *f.g*) which has been tucked off from the general endoderm in precisely the same way as the ectoderm forming the outer wall of the head rudiment has been tucked off from the general ectoderm. This tube of endoderm is the rudiment of the anterior portion of the alimentary canal or **fore-gut**. Immediately underneath the fore-gut is a narrower tube bifurcating at its hind end like a Λ . This is the rudiment of the heart, and the two branches into which it divides at its hinder end are the two **vitelline** veins which return the blood from the surface of the yolk. By this time the heart is usually commencing to grow actively in length with the result, owing to its being fixed at each end, that it bulges out on the embryo's right side. About the commencement of the second day of incubation the inner portion of the opaque area (Fig. 192, *a.v*) begins to assume a characteristic mottled appearance due

to localized thickenings of the splanchnic layer of mesoderm. These thickenings—the **blood islands**—gradually spread and become joined together into a network. This is the rudiment of a network of blood-vessels which has for its function the absorbing of food-material from the underlying yolk: the portion of opaque area in which the network is present is known as the **vascular area**. During the conversion of the strands of the at first solid network into blood-vessels the superficial cells of the strand become converted into the wall of the vessel while the enclosed cells become loosened from one another—fluid accumulating between them—and become the blood itself. The network of the vascular area is continued across the pellucid area to the vitelline veins into which the blood drains on its way back to the heart, but in the region of the pellucid area it is much less conspicuous, the network in this region forming only the thin walls of the vessels with fluid contents but without the opaque masses of corpuscles.

In an egg that has been incubated for nearly three days the embryo has the appearance depicted in Fig. 194. The blastoderm has now spread over about half the surface of the egg while the vascular area has also extended and is now much more conspicuous, the vessels being distended with bright red circulating blood. The yolk is assuming a much more fluid consistency than it had in earlier stages and the albumen is diminishing in amount. A striking change has come over the head region which, owing to its dorsal side growing more actively than its ventral, has become bent ventralwards into a kind of retort shape and, in correlation with this, has become twisted over so as to lie on its left side. Looking down upon the embryo in the opened egg one consequently sees the head region in side view, from its right side, while the portions of the embryo further back are still seen in dorsal view. The main regions of the brain are now quite distinct—the rhombencephalon with its thin membranous roof, the rounded bulging mesencephalon, and the thalamencephalon. In an embryo slightly more advanced than that figured there would be visible the rudiment of the pineal body—a median finger-like projection of the roof of the thalamencephalon—and of the hemispheres—laterally placed bulgings of its wall near its anterior end.

By this time the amnion has made its appearance. It originates as a fold of the somatopleure which rises up all round the body of the embryo and then grows inwards, overlapping the embryonic body so that the latter becomes gradually covered in as the opening bounded by the rim of the amniotic fold becomes smaller and smaller. In the three-day Fowl embryo the amniotic opening may still be seen (Fig. 194, *a.e*) and

it will be noticed that it is situated not over the centre of the embryonic body but towards its hind end—indicating that the growth of the amniotic

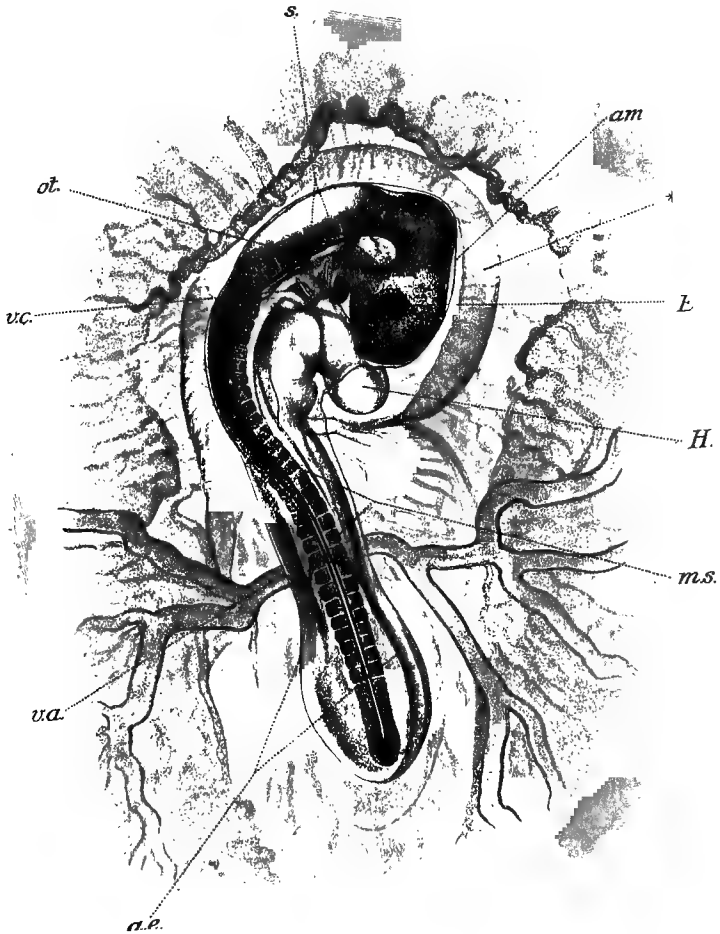

FIG. 194.

Third-day Fowl embryo viewed as a transparent object. *a.e.*, Edge of amnion; *am*, amnion; *E*, eye; *H.*, heart; *m.s.*, mesoderm segments; *ot.*, otocyst; *s.*, indications of pre-otic mesoderm segments (?); *v.a.*, vitelline artery; *v.c.*, visceral cleft II; * portion of splanchnopleure bulging downwards into the yolk, forming a recess in which lies the head of the embryo.

fold does not take place at an equal rate all round. As a matter of fact it first appears and grows most rapidly at the head end—forming a hood which grows back over the head region. The hinder and then the

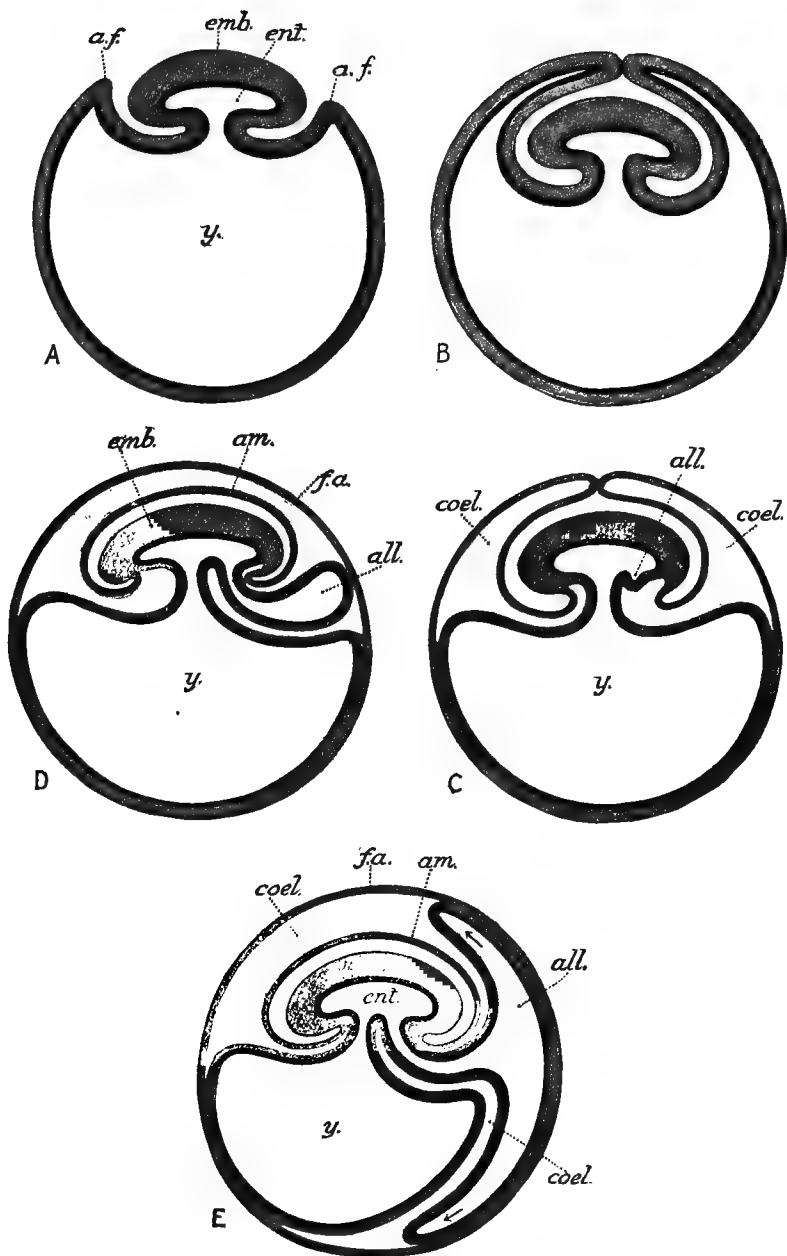

FIG. 195.

Diagram illustrating the evolution of amnion, etc. *a.f.*, Amniotic fold; *all.*, cavity of allantois; *am.*, amnion; *coel.*, coelome; *emb.*, body of embryo; *ent.*, cavity of enteron; *f.a.*, false amnion; *y.*, cavity of yolk-sac.

lateral portions of the fold appear later and develop more slowly. When the amniotic opening has completely disappeared the result is that the body of the embryo is covered in by two membranous roofs. Of these the inner, formed of the inner layer of the original amniotic fold, is the amnion in the strict sense ("true amnion," Fig. 195, D, *am*), while the outer formed from the outer layer of the original fold is known as the **false amnion** (*f.a*). The latter is simply continuous without a break with the rest of the somatopleure which extends outwards towards the limit of the blastoderm.

The cavity of the amnion, like other spaces in the developing egg, is full of secreted watery fluid and it forms a little tank in which in later stages the delicate body of the embryo floats, protected from injury by the sudden jars to which under terrestrial conditions eggs are exposed.

As regards the evolutionary origin of the amnion nothing is definitely known but on the whole it seems most probable that it arose through the body of the embryo, increasing in size within the confined space limited by the egg envelopes, being forced down in amongst the yolk, the surface of the blastoderm bulging up all round (Fig. 195, A). The network of blood-vessels in the blastoderm naturally performs a respiratory function, gas-exchange taking place between the blood in them and the external atmosphere. Consequently there would be a tendency towards increase in area of the blastoderm, and the bulging inwards over the surface of the embryo would tend to increase to the utmost limit until at last the amniotic opening would be obliterated (Fig. 195, B). With the splitting of the mesoderm to form the coelome the splanchnopleure would be withdrawn from the amniotic fold and the latter would now be a fold merely of somatopleure (Fig. 195, C).

Towards the end of the third, or early in the fourth, day the blood system assumes very interesting conditions. The heart is still in the form of a tube and its contraction, beautifully visible in the egg opened under warm salt solution, takes the form of waves which pass from behind forwards along its length. The tube no longer bulges simply towards the right but shows a double curvature, something like an S, the dorsal limb of which is destined to give rise to the atrium (Fig. 196, A, *at*) and the ventral to the ventricle (Fig. 196, A, *V*).¹ The latter is continued forwards as a short ventral aorta which gives off on each side three or four aortic arches (Fig. 196, A, I-III) between which are gill clefts. Dorsally the aortic arches of each side open into an aortic root and these are continued back into the unpaired dorsal aorta. In front the aortic root passes forwards into the head as the dorsal carotid

¹ Compare with the Elasmobranch heart as shown in Fig. 134, p. 321.

artery (Fig. 196, A, *d.c.*). From the hinder portion of the dorsal aorta which becomes again paired there passes straight out on each side a large **vitelline** artery (*v.a*) to supply the network of the vascular area.

Into the atrial portion of the heart there opens on each side a short vessel (*d.C.*), formed at its dorsal end by the meeting of two vessels one of which comes from the region of the kidney and the other from the head. Of these the short vessel is clearly the duct of Cuvier, that coming from

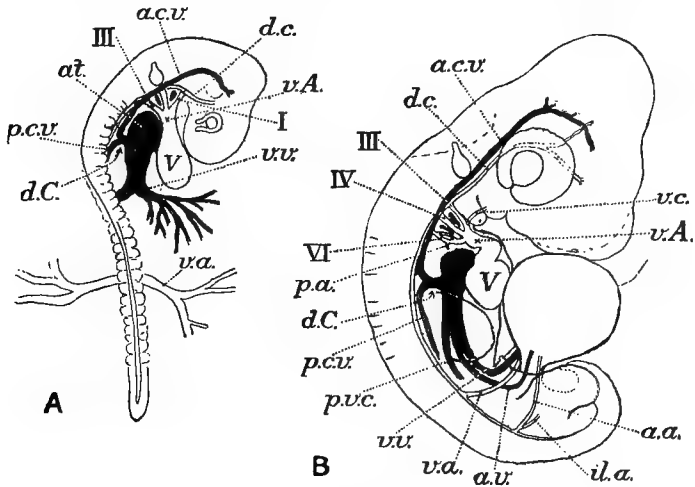

FIG. 196.

Diagram showing the main parts of the vascular system as seen in a Fowl embryo during the third day (A) and the fifth day (B). *a.a.*, allantoic artery; *a.c.v.*, anterior cardinal vein; *at.*, atrium; *a.v.*, allantoic vein; *d.C.*, duct of Cuvier; *d.c.*, dorsal carotid; *il.a.*, iliac artery; *p.a.*, pulmonary artery; *p.c.v.*, posterior cardinal vein; *p.v.c.*, posterior vena cava; *V*, Ventricle; *v.A.*, ventral aorta; *v.a.*, vitelline artery; *v.c.*, ventral carotid; *v.v.*, vitelline vein; I-VI, aortic arches.

the kidney (*p.c.v.*) the posterior cardinal vein, and that from the head (*a.c.v.*) the anterior cardinal.

The vitelline veins are present as before (*v.v.*) and form by their fusion the hinder end of the cardiac tube or heart.

It is naturally of great interest that in this early stage in the development of a Bird—one of the most highly evolved vertebrates—the heart should be in the extremely primitive form of a simple contractile tube, that there should be present typical aortic arches and typical gill clefts though these are never meant to carry out their primitive function, and finally that the main veins in the body should be precisely the same as those of a typical fish.

During the fourth day the allantois makes its appearance. At this time the splanchnopleure extends downwards over the surface of the yolk. Along the mid-line of the embryo, immediately under the notochord, a groove-like portion is tucked off from the rest. This groove is continued forwards and backwards as a blindly ending tube. The whole forms the rudiment of the alimentary canal (Fig. 195, A, *ent*) which therefore at this stage consists of three portions—an anterior tubular fore-gut, a posterior tubular hind-gut and an intervening mid-gut which opens freely below into the cavity filled with yolk—the **yolk-sac** (Fig. 195, A, *y*). The allantois arises as a pocket-like median downgrowth of the floor of the hind-gut (splanchnopleure) near its hinder end (Fig. 195, C, *all*). It becomes conspicuous during the fourth or fifth day as a rounded bladder projecting into the wide coelomic space. In a six-day egg the allantois has increased much in size and is coming in contact with the inner surface of the somatopleure (Fig. 195, D, *all*). Against this with further growth it flattens itself, taking on a mushroom-like shape and extending outwards all along its edge in close apposition to the somatopleure (Fig. 195, E). The somatopleure is now in close contact with the shell membrane over a great part of its extent, what is left of the diminishing albumen lying down in the lowest part of the cavity of the egg shell. The mesoderm covering that part of the allantois lying next the somatopleure has meanwhile become richly vascular, being supplied by a large **allantoic artery** (Fig. 196, B, *a.a*) and its blood draining into an allantoic vein (*a.v*) on each side.

This highly vascular outer wall of the allantois, which eventually as the chick increases in size comes to lie in close apposition to the inner surface of the shell, separated from it only by the very thin intervening layer of somatopleure, is the respiratory organ of the developing chick until it takes its first breath of air into its lungs just before hatching. The blood-vessels seen branching over the inner surface of the pieces of egg-shell from which a bird has hatched are those of the allantois, for it is a remarkable fact that the allantois, like the amnion and the greater part of the somatopleure, is of use only in the developing embryo and is discarded at hatching.

It should not be forgotten that the primary function of the allantois is that of a urinary bladder. In a terrestrial animal with its egg enclosed in a hard shell there is no possibility of the poisonous secretion of the kidneys diffusing away into the surrounding medium and consequently it is necessary to keep it stored in one spot where it will not injure the tissues in general.

The development of the Fowl affords a good example of the lower

grade of adaptation to a purely terrestrial existence occurring in the eggs of the majority of Reptiles and Birds, characterized (1) by the enclosure of the egg in elaborate protective envelopes, (2) by the development of an amniotic water-jacket to protect the embryo from jars, and (3) by the hypertrophy of the precociously developed allantois to serve in the first place as a reservoir for the renal secretion and in the second as a breathing organ. The higher grade of adaptation is found in the typical Mammal, where the egg instead of being laid is retained within the genital duct of the mother and leads therein a parasitic existence, so that the young individual instead of, on the one hand, having to fend for itself as in the lower vertebrates with free-living larvae, or on the other hand developing in the not absolutely safe shelter of the egg-shell, forms as it were, for the time being, simply a portion of an adult individual with completely developed powers of looking after itself. Correlated with this change in the conditions of development the egg of the mammal itself has greatly diminished in size, a supply of yolk being no longer necessary, and the elaborate protective envelopes so conspicuous in the reptile or bird have been reduced to the verge of disappearance. The allantois instead of performing a merely respiratory function performs a nutritive one as well, playing a principal part in the formation of a complicated organ—the **placenta**—for the extraction of nourishment from the mother.

We will illustrate the peculiarities of the mammalian type of development by the case of the Rabbit.

The egg is a spherical cell about $\cdot 1$ mm. in diameter. It is fertilized in the upper part of the oviduct and as it passes onwards undergoes the process of segmentation. In correlation with the disappearance of the yolk the segmentation has reverted to the holoblastic type. The egg divides into two, four, eight, and so on, the blastomeres being approximately equal. Eventually a solid sphere of cells is formed, consisting of an inner mass of rather more granular-looking cells enclosed in an outer layer ectodermal in its nature but given the special name **trophoblast** from the fact that its physiological activities are devoted to the absorption of nourishment. The egg now begins to increase rapidly in size, and takes the form of a vesicle distended by fluid and walled in by the layer of trophoblast, with the inner mass of cells adhering to its inner surface at one pole. The **blastocyst**, as the hollow vesicle is now called, becomes more and more distended with fluid, the trophoblast cells become broader and thinner while the inner mass of cells also becomes extended out into a comparatively thin layer covering, in the neighbourhood of the apical pole, the inner surface of the trophoblast over a considerable area. This layer of "inner-mass" cells now becomes differentiated into two layers—

an outer of more columnar cells in immediate contact with the trophoblast, and an inner of flatter cells, this latter extending beyond the margin of the columnar cells so as to come also into direct relation to the trophoblast. The blastocyst at this stage when observed as a whole is seen to form a clear-looking vesicle with a dim patch in the neighbourhood of one pole, this dim patch being the portion of the vesicle wall which has the "inner-mass" cells apposed to it. As will have been gathered all of this dim area except its marginal portion consists of three layers of cells. Of these the innermost is endodermal and the two outer ectodermal. Of the latter the outermost is part of the trophoblast while the middle layer will become the ordinary ectoderm covering the body of the embryo and the amniotic folds. Towards the margin of the dim patch only two layers of cells are present—trophoblast and endoderm. The portion of trophoblast in the central three-layered portion is sometimes given a special name—Raubert's layer: it disappears later and plays no part in further development.

The body of the embryo develops in the dim patch of blastocyst wall very much in the same way as it does in the blastoderm of the bird—primitive streak, medullary folds and so on making their appearance and going through a similar set of changes. In the case of the amnion a difference in detail is seen in the fact that it is here the tailward portion of the amniotic fold that develops most rapidly so that the amnion spreads over the body of the embryo from the tail end forwards.

During the early stages in its development the egg travels slowly down the genital duct but this progress ceases as it becomes distended, and towards the close of the seventh day the blastocyst becomes anchored to the uterine wall by fine tags or villi which sprout out from the surface of the trophoblast and burrow into the lining epithelium of the uterus. These villi are scattered irregularly over the surface of the blastocyst but there is a special development of them over a somewhat U-shaped area embracing the hinder end of the embryonic body. This special aggregation of tags or villi with the thickened cushion of trophoblast from which they spring is termed the **ectoplacenta** and it forms the foundation for the development of the true placenta.

The general arrangement of the parts in the blastocyst about ten days after fertilization is very much the same as in the Fowl's egg during the early days of incubation. We see the same layers of cells, the same parts of the neural rudiment, the amnion, the allantois. There is a large cavity with the endoderm spreading round it exactly like the yolk-sac of the Bird: in fact it clearly *is* the yolk-sac: but here it contains only watery fluid and no trace of yolk. Even had we no other

evidence we should be justified from this fact alone in concluding that the mammals have evolved out of ancestral forms in which as in Reptiles the egg was large and provided with abundant yolk.

The portion of somatopleure against which the allantois flattens itself is that which bears the ectoplacenta. The latter, composed throughout the greater part of its thickness of syncytial cytoplasm containing scattered nuclei, eats its way into the epithelium lining the uterus (Fig. 197, *E*) so that it comes into immediate relation with the underlying connective tissue. This is richly supplied with blood, there being, in place of capillaries, large irregular sinuses full of maternal blood (Fig. 197, *V*). The protoplasm of the ectoplacenta (*e*), as it burrows into the

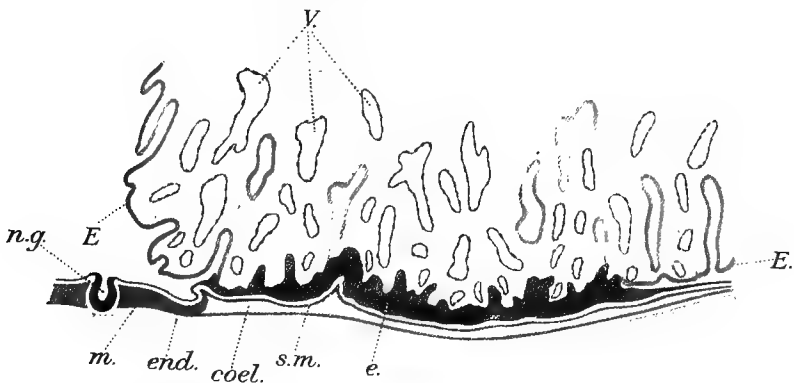
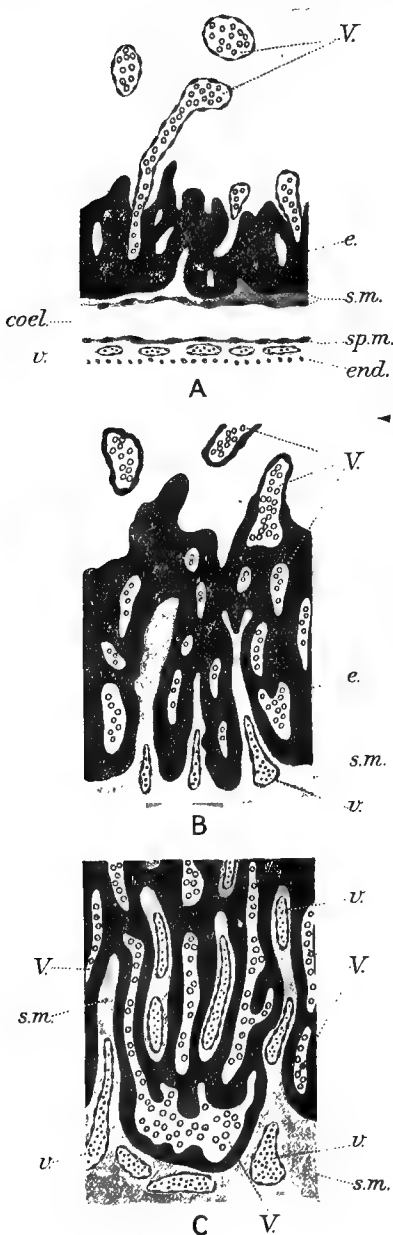

FIG. 197.

Section through part of blastocyst of Rabbit ($8\frac{1}{4}$ days) with the adjoining part of the uterine wall. (Simplified from Duval.) *coel.*, Coelome of embryo; *E*, uterine epithelium; *e*, ectoplacenta; *end.*, endoderm of embryo; *m.*, myotome; *n.g.*, neural groove; *s.m.*, somatic mesoderm; *V*, maternal blood-vessels of uterine wall.

substance of the uterine wall, tends to follow especially along the course of these maternal vessels, ensheathing them and destroying the original walls of the vessels so that the latter are now replaced by new walls formed of ectoplacenta (Fig. 198, A and B, *V*). While the ectoplacenta is invading the uterine wall in the way described, it has itself been invaded on its embryonic face by upgrowths from the underlying mesoderm formed by the fusion of the somatic mesoderm with the splanchnic mesoderm covering the allantois (Fig. 198, B). This intrusive mesoderm is richly supplied with blood from the allantoic vessels.

The placenta now takes on a distinctly columnar appearance when observed in microscopic sections, the wide tubular maternal blood sinuses (Fig. 198, C, *V*) with their wall of ectoplacental protoplasm alternating with masses of embryonic connective tissue (*s.m.*) containing



blood-vessels (*v*). The final important step in the development of the placenta is that the ectoplacental protoplasm becomes thinned out into a barely recognizable film and in places disappears entirely and the same happens to the connective tissue surrounding the embryonic blood vessels. When this stage has been reached the embryonic blood-vessels are in immediate contact with the maternal blood in the large sinuses, the two streams of blood—embryonic and maternal—being separated only by the very thin wall of the embryonic vessels, with it may be sparse remnants of ectoplacenta and connective tissue, through which oxygen and food-material readily pass from maternal blood into embryonic, and carbon dioxide and other excretory products in the opposite direction.

The placenta when completely formed is a large discoidal cushion composed partly of uterine lining and partly of embryonic tissue. It is connected

FIG. 198.

Diagrams illustrating the development of the placenta of the Rabbit. (Based upon Duval.) A, ninth day; B, tenth day; C, twelfth day. Each diagram represents a small portion of ectoplacenta, with the adjacent embryonic and maternal tissue. The ectoplacenta is shown in dark tone, embryonic connective tissue in medium tone, and maternal (uterine) connective tissue in pale tone. *coel.*, Coelome; *e.*, ectoplacenta; *en1*, embryonic endoderm; *s.m.*, somatic mesoderm; *sp.m.*, splanchnic mesoderm; *V*, uterine blood-vessels; *v.*, embryonic blood-vessels.

with the body of the embryo by the slender stalk of the allantois, which becomes much elongated and is enclosed along with the stalk of the yolk-sac in a tubular sheath of somatopleure; continuous on the one hand with the amnion and on the other with the body of the embryo. This somatopleural tube is known as the **umbilical cord**. At birth this is severed and the placenta together with the lining of the rest of the uterus is shed a little later as the **after-birth**.

It has already been pointed out that the general arrangements in the Rabbit blastocyst correspond closely with those in an early stage in development of the bird but that an important difference exists inasmuch as the yolk-sac is empty of yolk. As the body of the embryo increases in size the upper wall of the yolk-sac becomes pressed down against the lower and about the fourteenth day the latter begins to disintegrate and eventually disappears completely. When this process is accomplished a large proportion of the blastocyst surface consists of endoderm, exposed by the disappearance of the lower wall of the yolk-sac, and this probably plays a part in the nourishment of the embryo, absorbing food-material from the fluid within the uterus and passing it on to the body of the embryo by the rich network of blood-vessels in its mesodermal coat. These blood-vessels—constituting the vascular area—are confined to the upper wall of the yolk-sac, the mesoderm coating of the yolk-sac never extending beyond its margin.

Having now sketched the main peculiarities in the development of a Bird and a Mammal it will be of interest to take a more general view of these peculiarities in the Amniota as a whole. The mode of development seen in the Fowl holds not only for other birds but for the great majority of Reptiles. But it is of much interest to notice that even within the group Reptilia there are occasional genera which have become viviparous, the egg undergoing its development within a uterus. This holds for various snakes (e.g. the Adder—*Vipera*) and Lizards (e.g. *Chalcides*). Wherever this happens, and where in consequence vascular surfaces of embryo and mother come into close apposition, we might expect that the apposed surfaces would tend to come into still more intimate relations and develop something of the nature of a placenta to facilitate respiratory exchange between the embryonic and maternal blood-streams. This actually happens—to an extent differing in the different Reptiles in question, e.g. in *Chalcides tridactylus*, a common Lizard of Southern Europe, a definite allantoic placenta is formed while placental formation takes place in addition over the surface of the yolk-sac, the embryonic surface in each case closely interlocking with the lining of the uterus.

Amongst Mammals the Prototheria have not yet reached complete viviparity. The egg is comparatively large (3-4 mm. in *Echidna*) and is laid at a time when the embryo is still at a relatively early stage of development. In *Echidna* the mother transfers the egg to the pouch, where it remains until hatching takes place. In *Ornithorhynchus* the egg is deposited at the inner end of the burrow but nothing is known yet as to whether there is any incubation.

In the Metatheria matters have advanced a stage further. The egg has now lost nearly all its yolk and is reduced nearly to the size of the Eutherian egg. Development goes on for a considerable time within the uterus and in a few cases simple placental arrangements are developed from allantois and yolk-sac but the young when born are at a far less advanced stage of development than in the Eutheria. They attach themselves to the teats, situated as a rule within a pouch but sometimes freely exposed, and hang on to them continuously for a prolonged period while they go on with their development. In the small pouchless Opossums they remain with the mother, holding on by curling their tails round hers, long after there is any apparent necessity, and she presents a remarkable spectacle, almost hidden under the burden of a numerous family of young approaching herself in size.

In the Eutheria the most perfect condition of viviparity is reached. The placenta shows interesting differences in the different groups of Eutheria. These differences have to do in the first place with the general form and relations of the placenta. The allantois, instead of merely taking a somewhat mushroom form and giving rise to a discoidal placenta as in the Rabbit, may continue to spread all round its edge so that eventually the entire blastocyst wall is lined by allantois, very much as is the case in the Bird except that in the mammal it is commonly only the mesodermal covering of the allantois that becomes extended in this way, the primitive cavity with its endodermal lining being reduced or entirely absent. When such extension of the allantois or of its mesodermal sheath has taken place the villi over the whole surface of the blastocyst may become vascularized and converted into placenta, instead of merely the localized patch seen in the Rabbit. We thus get what is termed a **diffuse** placenta—such as occurs in the Pig or the Horse. Further modifications arise by secondary localization of placenta formation. Thus in the **cotyledonary** placenta found in Ruminants the placental structure is restricted to numerous little cushions or buttons scattered irregularly over the surface of the blastocyst—their location predetermined by special patches of the uterine lining. In the **zonary** placenta of the Cat, Dog, and other Carnivora, on the other hand, the

placenta forms a broad band round the equator of the blastocyst—the polar portions being clear of placenta.

Apart from these differences in general arrangement there are interesting differences in the degree of elaboration of the placenta in detail, more especially as regards the degree of intimacy of union between the embryonic and the maternal parts of the placenta. In the less highly evolved condition such as occurs in many diffuse placentas the embryonic villi simply fit into recesses or crypts of the uterine wall, lined by ordinary uterine epithelium, from which at birth they are withdrawn. Such an arrangement is not fitted for anything like so perfect an interchange between the maternal and the embryonic blood-streams as the arrangement seen in the Rabbit but the lesser degree of efficiency of the placenta in this respect is compensated for by the presence in the uterine cavity of a nutritive fluid—uterine milk as it has been called, containing protein, fat, and carbohydrate food-material secreted by the uterine epithelium, as well as blood extravasated from the uterine wall—which is absorbed by the trophoblastic covering of the blastocyst.

The more highly evolved types of placenta involve extensive interference with the normal uterine lining and in such cases the lining is shed and replaced by a new lining after each birth and it was formerly customary to attach great importance to this fact in classifying the various types of placenta, a sharp distinction being drawn between (1) “deciduate” placentas in which such shedding of the uterine lining with the placenta attached to it took place after birth and (2) “indeciduate” placentas where at birth the embryonic part of the placenta was simply withdrawn, leaving the uterine lining comparatively uninjured.

Apart from the readily understood absence of yolk, and its natural consequences the diminution in size of the mammalian egg and its reversion to the holoblastic type of segmentation, the most striking feature in the embryology of the typical mammal is the development of the body of the new individual from the “inner mass” of cells. What is the meaning of this inner mass of cells which we find in no vertebrate outside the group of mammals? How has it originated in evolution?

The answers to these questions appear to depend upon two facts. (1) The *bulk* of the young developing vertebrate is controlled by limiting factors, such as the rigid egg-shell in the case of a bird, or the necessity of not interfering with the health of the containing maternal body in the case of the mammal. (2) A certain amount of free space has been made available in the interior of the mammalian blastocyst by the disappearance of the yolk.

As a result of these two conditioning factors the portion of blastocyst

wall destined to give rise to the body of the embryo, in which is therefore concentrated the greatest developmental activity, is hindered in the increase in area which would be the normal result of its growth and in consequence it has found accommodation by bulging inwards and giving rise to the inner mass.

If this is a true explanation of the nature of the inner mass we should expect that this might become apparent through the inner mass opening out and resuming its primitive condition as a part of the blastocyst wall in the event of the restrictions upon its extension becoming lessened in later stages of development. This actually happens and some of the most striking peculiarities in the early development of particular types of mammal are due to the great differences in the length of the period

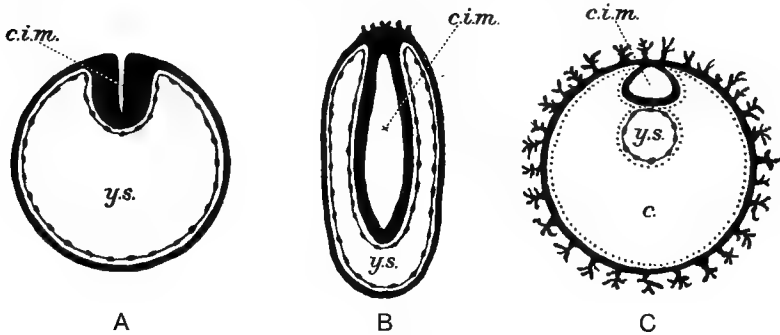

FIG. 199.

Diagrammatic sections through blastocyst of *Tupaia* (A), Mouse (B), and Man (C). (A, after Hubrecht; C, after Bryce.) *c.*, Coelome (precociously developed); *c.i.m.*, cavity of inner mass; *y.s.*, cavity of yolk-sac.

during which the expansion of the portion of blastocyst wall under discussion is restricted.

In a relatively primitive insectivorous mammal *Tupaia* a cavity develops in the ectodermal portion of the inner mass at a very early stage (Fig. 199 A, *c.i.m.*), and this presently comes to open to the exterior and the whole inner mass opens out so as to form simply a part of the blastocyst wall in the manner we should expect. In the Rabbit the same condition is attained at an early period, though here there is no trace of the "opening out" process, the mass simply spreading outwards into a thin layer. In a Vole (*Arvicola*) as in *Tupaia* a space makes its appearance in the interior of the inner mass but the flattening out process is delayed until a period after the amniotic folds have made their appearance. The meeting of these folds isolates the amniotic

cavity from the remainder of the space in the interior of the inner mass.

In the Mouse there is still greater delay, for the ectodermal part of the inner mass remains solid until a period corresponding to that in the Vole when the amniotic folds have already met. It is only then that two cavities develop, one over the other, along the centre of the inner mass. These two cavities become for a time continuous (Fig. 199, B), but eventually the lower part becomes separated off to form the definitive amniotic cavity while the upper portion becomes obliterated.

It seems clear from the few known early stages of Human development, such as the Bryce-Teacher blastocyst, that in Man also the amniotic cavity arises as a closed space within the inner mass. A striking feature in the early blastocyst of Man and of Apes (Fig. 199, C) is the great reduction in the size of the yolk-sac (*y.s.*), correlated with a precociously developed wide coelomic space (*c.*) separating it from the wall of the blastocyst.

It will have been gathered that in the Amniota in general the young individual during its embryonic development is enclosed in a water jacket, the amnion, and that this in turn is enclosed within an outer wall of somatopleure constituted by the false amnion and its continuation, with the inner surface of which may be fused to varying extents the allantois and yolk-sac. All these structures are referred to collectively as the embryonic membranes or foetal membranes of the amniote. Within these the young individual undergoes gradual development and growth until at last they are ruptured and it is set free. This process of hatching takes place in birds and in most reptiles long after the egg has passed from the body of the mother: in *Echidna* it takes place within the pouch; in the typical mammal it takes place within the uterus.

A long time before the young animal breaks its way out from the foetal membranes muscular movement commences, and in the majority of amniotes, in which sharp claws are present, the movements of the limbs would be liable to tear the delicate amnion and thus bring about the death of the embryo. As was discovered by Agar this danger is guarded against by a beautiful adaptive arrangement; the concavity of the claw being filled up during the period of embryonic existence by a smooth rounded cushion which renders it quite incapable of injuring the amnion.

INDEX

References to **Figures** in **Clarendon** type.

- Acalephae, 101-106
Acanthia, 242
Acanthias, **294**
Acanthobdella, 157
Achromatin, 3
Aciculum, 145
Acineta, **75**
Acinetaria, 74
Acipenser, **371**
"Acquired" characters, 194
Actinophrys, 30
Actinopoda, 28
Actinopterygian, 365
Actinosphaerium, 28-30, **29**
Actinozoa, 115
Adamsia, 112
Afferent nerves, 97
Agglutination, 5
Air-bladder, 355-358, **366, 367, 376**
Air-capillaries, 431
Air-sacs, 430
Agriculture, amoebae in, 17
Ague, 60
Albumen, 456
Alcyonaria, 110
Alcyonium, 106-110, **107, 108**
Alimentary canal, 85, 129
Allantois, 409, 466, 467
Alternation of generations, 24, 99
Ambulacrum, 282
Amia, **371**
Ammocoetes, 396 (foot-note)
Amnion, 419, 461, **463**
Amoeba, 1-18, **2, 6, 8, 10**
Amoebaea, 18
Amoebic dysentery, 15
Amoebocytes, 86
Amoeboid movement, 3, 12
Amoebula, 55
Amphicoelous, 316
Amphioxus, **392**
 development, 449
Ampulla, 286
Anabolism, 13
Anadromous, 362
Analogy, 143
Anatomy, 11
Ancylostoma, 200, **201, 202**
Annelida, 158
Annulus, 153
Anodonta, **269**
Anopheles, 59, **247**
Antenna, 226
Antennule, 226
Anthomedusa, 100
Ants, 244, 245
Anus, 131
Aphides, 241
Aphrodita, 147
Appendages (arthropoda), 216-230
Aptera, 241
Arcella, 18
Archenteron, 104
Archinephric duct, 307
Archinephros, 307
Archipterygium, 379
Arenicola, 148
Aristotle's lantern, 285
Arteries, 322, **425, 433, 442, 465**
Arthropoda, 209
Ascaris, 178-197, **179, 199**
Ascon, 118, **119**
Asexual reproduction, 24
Association, 54
Astacus, **224**
Asterias, 282
Astroides, 113
Atrium, 394
Auditory capsule, 317
 ossicles, 445
Aulostoma, 157
Aurelia, 101-106, **102, 104**
Auto-infection, 58
Autolytus, 147
Autostylic skull, 349

Babesia, **64**
Barnacles, 265
Basal granule, 35, 43
 plate, 296

- Basement-membrane, 296
 Bee, 244
 disease, 66, 258
 Bilateral symmetry, 143
 Bile, 302
Bilharzia, 167-170, **168**
 Binomial system, 14
 Birds, 427-435
 Blackhead, 257
 Bladder, urinary, 409, 441, 466
 Blastocyst, 467, 473, **474**
 Blastoderm, 458
 Blastomeres, 188
 Blastostyle, 95
 Blastula, 94
 Blood, 85, 235, 325, 394
 circulation, **381**
 islands, 461
Bombus, 228
 Bone, 292, 295, 352
 Bot, 253
Bothriocephalus, **176**
 Botryoidal tissue, 155
 Brain, 327, 329, **330**, 361, 368, **386**, **387**,
 395, 399, 426, 446, 458, 461
Branchellion, 158
 Branchiostegite, 226
 Bronchus, 409
 Buccal cavity, 133
 Budding, 93
 Bumble-bee, 228
 Butterfly, **214**, 229
- Caecum, 153
 Calcarea, 124
 Calciferous glands, 134
 Calyptoblastic, 100
 Canal-system, 122
 Capillary blood-vessels, 140
 Carriers of microbes, 17
 Cartilage, 292
 Catabolism, 13
 Catadromous, 363
 Cell, 11, 215
 Cement-organ, 370, 391
 Centipedes, 240
 Central capsule, 31
 Centrosome, 184, 196
 Cephalothorax, 211
Ceratodus, **374**
Ceratopogon, 250
 Cercaria, 165
 Cerebro-spinal fluid, 388
 Cestoda, 171
 Chaeta, 131
 Chalaza, 457
 Chalk, 25
 Cheiropterygium, 405
 Chela, 217
 Chelicera, 217
 Cheliped, 225
- Chemotaxis, 10
 Chilaria, 218
 Chitin, 210, 234
Chiton, 278, 280
 Chlamydozoa, 80
 Choanocytes, 118
 Choroid plexus, 388
 Chromatin, 3
 Chromatophores, 34
 Chromidia, 21
 Chromosomes, 8, 182, 188, 195
 Chrysalis, 213
Chrysops, 251
 Cicada, 241
 Cilia, 69
 Ciliata, 67-74
Cimex, 242
Cirratulus, 147
 Cirrus, 145
Clathrina, 121
 "Cleg," 251
Clepsine, 158
 Clitellum, 132
 Cloaca, 302
Clonorchis, 170
 Cnidoblast, 89, **90**
 Cnidocil, 89
 Cnidosporida, 65
 Cockroach, 227
 Cocoon (*Lumbricus*), 140
 Coelenterata, 115
 classification, 86
 Coelenteron, 88
 Coelome, 129
 Coelomic epithelium, 133
 fluid, 135
 Coenenchyme, 113
 Coleoptera, 243
 Collar-cell, 118
 Columella (coral), 113
 (ear), 407
 Conchiolin, 268
 Connective tissue, 130
Conorhinus, 49, 242
 Contractile vacuole, 5, 28, 68
Copromonas, 35, **36**, **37**
 Coral, 113
Corallium, 110
 Cortex, cerebral, 387, 447
 Coxal glands, 233
 Cranial nerves, 332-337
 Cranium, 317
 Cretinism, 305
 Crop, 133
 Crossopterygian, 365
 Crustacea, 258
 Crystalline cone, 237
 style, 276
 Ctenidium, 271
Culex, **247**
Culicoides, 250

- Cuticle, 89, 132
Cyanea, 106
 Cyclical infection, 44, 46, 48
 Cycloid scales, 350, **352**
Cyclops, **204**, 263
 Cyst, 9
 Cysticercus, 171
 Cystospore, 29
 Cytoplasm, 2

Daphnia, **261**
 Delamination, 455
 Delhi boil, 51
 Demersal, 362
 Demospongiae, 125
 Dengue fever, 80
 Dentine, 295
 "Depression," 71
 Dermal epithelium, 119
 Diaphragm, 441
 Diastole, 5
Didelphys, **403**
Diffugia, 18
 Digestion, 6, 92
 Digestive ferment, 7
 Dimorphism (*Polystomella*), 21
 Diploid, 182
 Diptera, 246
Dipylidium, 175
 Direct infection, 44
 Directive mesenteries, 112
Distoma, 159, **160**
 Dogfish, 294-346
 Dorsal, 130
 Dorsal pores, 136
 Dourine, 47
Dracunculus, 203
Drepanidium, 61
 Ductless gland, 304
 Dyads, 184

 Ecdysis, 213
 Echinoderm larvae, **289**, 290
 Ectoderm, 88
 Ectoplacenta, 468
 Ectoplasm, 2
 Eel, 363
 Efferent nerve-fibre, 98
 Electric organs, 347, 348, 362, 363
 Elephantiasis, 206
 Elytra, 147, 230
 Embryo, 94 (foot-note)
 Enamel, 296
 Endoderm, 88
 Endoplasm, 2
 Endopodite, 223
 Endostyle, 393, 397
Entamoeba, 15, **16**
 Enteron, 129
 Enzymes, 6
 Ephippium, 263

Ephydatia, 127
 Ephyra, 105
 Epidermis, 132
 Epididymis, 156, 423
 Epipodite, 225
 Epithelium, 89
 Eruptive lobopods, 3, **4**
 Erythrocytes, 325
Euglena, 33, **34**, 35
Eumice, 147
Euplectella, 125, **126**
Euspongia, 127 (foot-note)
 Eustachian tube, 408
 Eutheria, 436, 472
 Euthyneury, 277
 Excretion, 5
 Exopodite, 223
 Exoskeleton, 113, 210, 212, 215, 267
 Eye, 236, 238, **279**, 337-342, **339**, **341-361**,
 400, **459**
 Eye-muscles, 333

 Faecal matter, 7
Fasciola, 158-166, **159**, **163**
Fasciolopsis, 170
 Fatty body, 232, 410
 Feathers, 427
 Ferments, 6
 Fertilization, 186, **187**
Filaria, 205
 Fin-skeleton, 298, 319, **379**
 Finger and Toe disease, 27
 Fins, 294
 Fire-flies, 232
 Fission, 7
 Amoeba, **8**
 Hydra, 93
 Flagellata, 33-51
 Flagellum, 23
 Flame-cells, 161, **162**
 Fleas, 254
 Fluid vacuoles, 3
 Food of animals, 13
 Food-vacuole, 5, 29, 70
 Foot (mollusca), 274
 Foot and Mouth disease, 80
 Foraminifera, 19
 Fore-gut, **459**, 460
 Fumigation, 250
Fungia, 114, **115**
 Furcula, 434

 Gadfly, 251
 Gall-bladder, 302
 Galvanotaxis, 10 (foot-note)
 Gamete, 23
 Gametocyte, 40
 Gametogenesis, 182
 Ganglion, 142
 Ganglion-cell, 97
 Ganoid, 365

- Gas vacuoles, 3, 19
 Gastral filaments, 102
 Gastrula, 104, **451**
 Gemmule, 123
 Genital pore, 398
 Genus, 14
 Germ-track, 194, 197
 Gill-books, 219, **222**
 Gill-cleft, 298, 396
 Gill-rakers, 299
 Gill-rays, 318
 Gill-septum, 299
 Gills, 231, **299**, 353, **354**, **355**
 external, 370, 390
 Gizzard, 133
 Gland, 302
 Gland-cell, 89
 Globigerina ooze, 25
 Glomerulus, 310
 Glossa, 228
Glossina, 253
Glossina morsitans, 46, 48, 49
Glossina palpalis, 44, 48
 Glycogen, 16
 Gnathobase, 218, **222**
 Goitre, 305
 Gonad, 41, 85, 137, 188, 192
 Gonothea, 95
Gorgonia, 110
Grantia, 121, **122**
 Green gland, 233
 Gregarinida, 63
 Growth, 7, 13, 212
 Guarnieri's bodies, 80
 Gymnoblasic, 100
- Haemal arch, 315
Haematopota, 251
 Haemocoel, 211 (foot-note), 231, 235
 Haemocyanin, 235
 Haemoglobin, 141, 155
Haemoproteus, 63
 Haemosporidia, 63
 Hair, 437
 Halteres, 230
 Haploid, 182
 Haplosporidia, 67
 "Harvest-bug," 258
 Heart, 320, **321**, 360, 368, **383**, 394, 412,
 423, 432, 464
 Heliotropism, 10 (foot-note)
Helix, **269**
 Hemiptera, 241
 Hemispheres (brain), 331, 361, 369, 387,
 447
 Heredity, 193, 196
 Hermaphroditism, 91, 137
 Heterocercal, 294
 Heteronereis, 145
 Heterotricha, 72
 Hexactinellida, 124
- Hippospongia*, 127 (foot-note)
 Hirudinea, 157
Hirudo, 153-157
 Histolysis, 215
 Holoblastic, 454
 Holophytic nutrition, 35
 Holotricha, 72
 Homocercal, 349
 Homodynamy, 143
 Homiothermic, 427
 Homologous chromosomes, 188
 Homology, 143
 Homoptera, 241
 Hormones, 304 (foot-note)
 House-fly, 229, 251
Hyalonema, **125**
 Hydatid cysts, 177
Hydra, 87-94, **88**
 "Hydra tuba," 105
 Hydrida, 106
 Hydrocoele, 286
 Hydroid, 95
 Hydromedusae, 94-101
 Hydrophobia, 80
 Hydrotheca, 95
 Hydrozoa, 106
 Hymenoptera, 243
 Hyoid arch, 319
 Hyostylic, 319
Hypogeophis, **406**
 Hypopharynx, 228
 Hypotricha, 73
- "Imaginal discs," 215
 Imago, 213
 Impressed characters, 194
 Infection, direct and cyclical, 44, 46, 48
 Inflammation, 262
 Infusoria, 67
 Ingestion, 6
 Inhalent canals, 122
 Inheritance, 193, 196
 Ink-sac, 276
 Insects and disease, 43, 46-51, 59, 62, 77,
 78, 80, 246, 251, 253, 255
 and light, 233
 Internal medium, 86, 304
 Internal secretion, 304
 Interstitial cells, 89
 Intervertebral ligaments, 316
 Intestine, 133
 Itch-mite, 257
- Jigger, 255
- Kala azar, 50
 Karyokinesis, 8
 Karyosome, 42
Kerona, 73
 Kidney, 311
 Kineto-nucleus, 43

- Labial palp, 228
 Labium, 228
 Labrum, 228
Lacerta, 403
 Lamprey, 396
Lankesterella, 61
 Larva, 94 (foot-note)
 Larynx, 409
 Lateral line organs, 345
 Leeches, 157
 Leishman-Donovan bodies, 50
Leishmania, 50
 Lepidoptera, 245
Lepidosiren, 374, 390, 391, 403
Lepidosteus, 371
 Leptomedusa, 100
 Leucocytes, 325
Leucosolenia, 118-121, 119
 Lice, 255
 and disease, 77, 255
 Light (insects and), 233
 Ligula, 228
 Limb-girdles, 320, 405
 Limb-skeleton, 379, 404
 Limbs, evolution, 390, 402, 420
Limulus, 218, 219, 256
 Lingua, 228
 Liver, 302, 394
 abscess, 15
 Lobopod, 3 (foot-note)
Lumbricus, 130-144
 Lung, 366, 367, 374, 408, 422, 440
 Lung-book, 223
 Lung-fish, 372
 Lymph, 326, 416
 Lymphatic glands, 444
- Macrogamete, 40
 Macronucleus, 69
 Madrepore, 114
 Madreporite, 287
 Mal de caderas, 47
 Mallory's bodies, 80
 Malpighian body, 310
 tubes, 234
 Mammals, 436-448
 Mammary glands, 438
 Mandible, 225
 Mandibular arch, 318
 Mange, 257
 Mantle, 270
 Manubrium, 97
 Marsupials, 436
 Maturation of gametes, 30, 37, 58, 182-186
 Maxilla, 225
 Maxillary palp, 227
 Maxilliped, 225
 Maxillula, 225
 "Measly" beef, 176
- Measurement, microscopic, unit of, 15
 (foot-note)
 Meckel's cartilage, 318
 Medullary folds, 327, 458
 plate, 327
 Medusa, 96-99
 Megalosphere, 63
 Meganucleus, 69
 Meiosis, 183
 Meiotic divisions, 186
 Melanin, 55
 Meroblastic, 454
 Merotomy, 10
 Merozoites, 58
 Mesenchyme, 116, 120
 Mesenterial filament, 108
 Mesenteron, 231
 Mesentery, 107
 Mesoderm, 129, 452, 460
 Mesogloea, 88, 110
 Mesonephros, 308
 Mesosoma, 211
 Metabolism, 13
 Metamerism, 143
 Metamorphosis, 213, 214
 Metanephros, 308, 441
 Metasoma, 211
 Metatheria, 436, 472
 Metazoa, 84, 137
 Microgamete, 41
 Micronucleus, 69
 Microsphere, 23
 Microsporidia, 66
 Midge, 250, 251
 "Miescher's tubes," 67
 Miracidium, 164, 167
 Mites, 257
 Mitosis, 8, 187, 193, 195, 372
 Monads, 185
 Monaxon spicules, 120
Monocystis, 52, 53
 Morphology, 217 (foot-note)
 Mosquito, 227, 228, 246, 247
 Mosquitos and disease, 59, 62, 80, 248
 Mouth appendages of insects, 227
 Movement, amoeboid, 3
 euglenoid, 35
 Müllerian duct, 311, 359, 441
Musca, 229, 251
 Muscle, 85, 116, 306
 Mussels and disease, 281
 Mycetozoa, 26
 Myo-epithelial cell, 89, 179
 Myoneme, 72
 Myotomes, 305, 453, 460
Myrianiada, 147
 Myriapoda, 240
Mytilus, 273
Myxidium, 66
Myxine, 396
 Myxosporidia, 66

- Nacre, 268
 Nagana, 46
 Names of animals, 14
 Nares, 389
 Nauplius, 263
Nautilus, 267, 270, **271**, 274, 276, 279
Necator, 203
 Negri bodies, 80
 Nematocyst, **90**
 Nematode life-histories, 197-208
 Neopallium, 447
 Neosporidia, 65
 Nephridia, 86, 135, 233, 394
 Nephridial organs of vertebrates, **308**,
 309, **310**
 Nephrostome, 135
Nereis, **144**
 Nerve centre, 97, 116
 commis sure, 142
 fibre, 97
 ganglia, 142
 loop, **277**
 plexus, 97
 Nervous system, 85, 141
 Nervures, 229
 Neural arch, 314
 spine, 316
 tube, 326, 458
 Neuropodium, 144
 Neuroptera, 242
Nosema, 66
 Notochord, 292, 314, 394
 Notopodium, 144
 Nucleus, 2
 Nummulites, 26
 Nutrition in animals and plants, 51

Obelia, 94-99, **95**, **96**, **100**
 Odontoblasts, 295
 Oesophagus, 133
 Olfactory capsule, 317
 organ, 337, 362, **389**, 400
 Oligochaeta, 152
 Ookinete, 59
 Operculum, 353
 Opisthocoeelus, 370
 Opisthonephros, 308, 398
 Opisthosoma, 211
 Oral cone, 87
 Orthoptera, 241
 Osculum, 118
 Osphradium, 277
 Ostium, 235
 Otocyst, **98**, **103**, 236, **343**, 417
 Otolith, 98, 362
 Ovary, 91, 311
 Oviducal gland, 313
 Oviduct, 139, 311, 359
 Ovipositor, 243
Oxyuris, 200
 Oysters and disease, 281

 Pallial complex, 270, **272**
 Pallium (brain), 388, 434
 Palp, 145
 Pancreas, 303
 Pappataci fever, 80
 Paraglossa, 228
 Paraglycogen, 52
Paragonimus, 170
Paramecium, 67-72, **68**
 Paramylum, 35
 Parapodium, 144
 Parasitism, 32, 265
 Parthenogenesis, 207, 244
 Pearls, 268
Pectinaria, 149
 Pectines, 223
 Pedicellariae, 284
 Pedipalp, 220
 Pelagic, 24
 Pellicle, 68
 Pericardiac cavity, 307, 398, 409
 Pericardio-peritoneal canal, 307
Peripatus, **211**, 240
 Perisarc, 95
 Peristaltic contraction, 134
 Peristome, 69
 Peristomium, 145
 Peritoneal canal, 310
 cavity, 307
 funnel, 310, 409
 Peritricha, 73
Petromyzon, **396**
 Phagocytes, 135
 Phagocytic organs, 181
 Pharynx, 133
Phlebotomus, 251
 Photogenic organs, 232
 Phototaxis, 10 (foot-note)
Phylloxera, 241
 Phylum, 18
 Physiology, 11
 Pineal organ, 330, 400, 426
Pivoplasma, **64**
 Pituitary body, 331, 365, 400
 Placenta, 467, **469**, **470**
 Placoid scale, **295**
 Plankton, 24
Plasmodiophora, 27
 Plasmodium, 26, 179
Plasmodium, 55-62, **56**, **61**
 species, 60, **61**
 Pleuronectidae, 364
 Poikilothermic, 427
 Polar bodies, 185
 capsules, 65, **66**
 Polychaeta, 152
Polygordius, development, 150
Polynoë, 147
 Polyp, 95
Polypterus, **365-369**
Polystomella, 19-24, **20**, **22**

- Pomatoceros*, 149
 Pore, 120
 Porifera, 122
 Porocyte, 120
 Pre-otic = anterior to otocyst
 Prestomial tentacles, 145
 Prestomium, 131
 Primitive streak and groove, 458
 Primordial germ-cell, 192
 Proctodaeum, 231
 Proglottis, 171
 Pronephros, 308
 Prosoma, 211
 Protarthropoda, 239
 Protein, 2
 Proteomyxa, 27
Proteosoma, 63
Proterospongia, 127
 Protobranchiata, 275
 Protocercal, 350
 Protonephridium, 152
 Protoplasm, 1
Protopterus, 374
 Protostoma, 104, 116, 150
 Protostylic, 381
 Prototheria, 436, 472
 Protozoa, classification, 18
 and disease, 81
 Prowazek's bodies, 80
 Pseudobranch, 300
 Pseudo-navicella, 55
 Pseudopodia, 3
Pseudospora, 27
 Pupa, 213
 Pyloric caeca, 359
 Pylorus, 300
 Pyorrhoea, 78, 79
- Quartan fever, 60
- Rachis, 181
 Radial canal, 98
 Radial symmetry, 143
 Radiating chambers, 122
 Radiolaria, 30, 31, 32
 Radiolarian ooze, 33
 Radula, 275
Rana, 406
 Rats and disease, 78
 Rauber's layer, 468
 Reaction to stimulus, *Amoeba*, 9
 Receptaculum ovarum, 139
 Rectum, 302
 Recurrence of malaria, 61
 "Red coral," 110
 Redia, 165
 Red-water fever, 64
 Relapsing fever, 77
 Renal portal, 324, 385, 433
 Residual protoplasm, 54
 Respiration, 231, 390, 408, 423, 430
- Retina, 237
 Retinula, 237
Rhinosporidium, 67
 Rhizopoda, 28
 Rhynchota, 241
 Ribs, 317
 Ring canal, 99
 Rod, 237
 Rostellum, 171
 Rudiment, 241 (foot-note)
- Sabella*, 150
 Saline solution, normal, 52 (foot-note)
 Salivary glands, 231
 Sand-fly, 250, 251
 fever, 80
 Sarcodina, 18-33
Sarcoptes, 257
 Sarcosporidia, 66
 Scabies, 257
 Scales, 295, 350, 352, 421
 Scaphognathite, 226
 Scarlet fever, 80
Schistosoma, 167-170, 168
 Schizogony, 22
 Schizont, 55
Schizotrypanum, 49 (foot-note)
 Scleroblasts, 110, 120
 Scolex, 171
 Scorpion, 220, 221, 256
Scyllium, 294
 Scyphistoma, 105
 Sea-anemones, 111
 Sebaceous glands, 438
 Secondary subclavian, 433
 Secretion, 6, 89
 Segmentation of body, 143
 of egg, 94, 188, 450, 454, 467
 Seminal vesicle, 139, 313
 Sense-organ, 98
 Sensory bristles, 236
 cell, 97
 nerve-fibre, 97
 tentacle, 103
- Sepia*, 269
 Serial homology, 143
Serpula, 149
 Sessile animals, 142
 Sex, 41, 197
 chromosomes, 189, 190, 196
 Sexual dimorphism, 167
 reproduction, 24
 Shagreen, 297
 Sheep-ked, 254
 Shell-gland, 164, 233
 Sieve-membrane, 119
 Silk, 246
 Silkworm disease, 66
Simocephalus, 260
Simulium, 251
 Siphuncle, 270

- Skeleton, 85
 Sleeping-sickness, 43, 47-49
 Smallpox, 80
 Snakes, 421
 Social insects, 242, 244
 Solenocyte, 162, 394
 Soma, 41, 85, 191-194
 Somatic mesoderm, 460
 Somatopleure, 460
 Somite, 130
 Species, 14
 Spermatheca, 140
 Spermatids, 185
 Spermatozoon, 42
 Sperm-morula, 52, 138
 Sperm-sac, 313
 Spicules, 110, 124
 Spiders, 256
 Spinal nerves, 327, 328
 Spiracle, 300
 Spiral valve (intestine), 377
 Spirochaetes, 76-80, 79
Spirorbis, 150
Spiroschaudinmia, 77
 Splanchnic mesoderm, 460
 Splanchnocoel, 307
 Splanchnopleure, 460
 Spleen, 326
Spongilla, 127
 Spongine, 126
 Spore, 26
 Sporoblasts, 60
 Sporocyst, 165, 168
 Sporogony, 58
 Sporozoa, 51-67
 Sporozoites, 55, 60
 "Staggers," 175
Stegomyia, 250
Stentor, 72, 73
 Stigma, 34, 223
 Sting, 243
 Stolon, 95
 Stomodaeum, 107
Stomoxys, 253
 Stone-canal, 287
 Streptoneury, 277
 Strobila, 105
Strongyloides, 207
 "Sturdy," 175
 Surgeon, 371
Stylonychia, 73
Stylorhynchus, 54
 Subclavian artery, 433, 443
 Subgenital pit, 102
 Suctoria, 74
 Suprarenal, 410
 Surra, 46
 Sweat-glands, 438
 Swim-bladder, 355-358
 Sycon, 121
 Syllidae, 146
 Symbiosis, 32, 92
 Symmetry of the body, 143, 290
 Sympathetic nervous system, 417
 Syncytium, 26, 179
 Syndesis, 183, 189, 195
 Syngamy, 23, 30, 37, 54, 59, 71, 186, 187, 190
 Syphilis, 78
 Syrinx, 431
 Systole, 5

Taenia, 171-177, 172, 176
 Tape-worms, 171-178
 Teeth, 297, 374, 375, 397, 421, 439
 Telosporidia, 63
 Telson, 212, 223
 Temperature in malaria, 59
 Tentacles, 87
Terebella, 149
Teredo, 274
 Termites, 242
 Tertian fever, 60
 Testis, 91, 311, 368, 377, 378
 Tetrads, 183
 Texas fever, 64
 Theca, 113
 Thymus, 305
 Thyroid, 303, 398
 Ticks, 257
 and disease, 64, 65, 77, 258
 Tiedemann's bodies, 288
Tokophrya, 75
Tomopteria, 148
 Toxin, 58
 Trachea, 232, 409
 Trachoma, 80
 Tractellum, 35
 Transverse process, 317
Treponema, 78
Trichina, 197, 198
Trichocephalus, 199, 200
 Trichocysts, 68
Trichodina, 74
 Triradiate spicules, 120
 Tristeza, 64
Triton, 403, 408
 Trochosphere, 151
 Trophoblast, 467
 Trophozoite, 53
 "Tropical fever," 60
 ulcer, 51
Trypanosoma, 42-49, 43, 45
 species, 46
 Trypanosome fever, 47
 Tryptic ferment, 7
 Tsetse, 46
 Tube-feet, 282
Tubularia, 99, 100
 Tympanum, 407
 Typhlosole, 133

- Umbilical cord, 471
 Umbrella, 97
 Urea, 302
 Urino-genital sinus, 313
 Uterus, 164
- Vacuole, 3
 contractile, 5, 28, 68
 Vas deferens, 139, 311
 Vas efferens, 139, 311, 410
 Vascular system, 85
 Veins, 324, 385, 399, 433, 443, 465
 Velum, 393, 396
 Vena cava, 385
 Ventral, 130
 Vertebral centrum, 316
 column, 316, 416
 Vertebrata, general characters, 292
 Vestige, 241 (foot-note)
 Visceral clefts, 300
 hump, 268
 Vitelline arteries, 465
- Vitelline membrane, 456
 veins, 460
 Vitrella, 237
 Vitreous body, 237
Volvox, 38-42, 39
Vorticella, 73
- Warble, 253
 Wings (insects), 229
 Wolffian duct, 311, 410
- Yaws, 78
 Yellow cells, 135
 Yolk, 453, 455
 Yolk-cells, 162
 Yolk-glands, 162
 Yolk-sac, 466, 468
- Zoaea, 259, 260
 Zoantharia, 111-115
 Zygote, 24

THE END

TEXT-BOOK OF EMBRYOLOGY

With Illustrations. Medium 8vo.

VOL. I

INVERTEBRATA

BY

PROFESSOR E. W. MACBRIDE, F.R.S.

31s. 6d. net.

“This work at once takes a place in the foremost rank of embryological studies. It will prove indispensable to all earnest students of zoology.”—*The Lancet*.

“The book reaches and maintains a very high level, and the need for such a work has long been felt by the student of biology in this country. It has the outstanding merit of being concise, easily followed, and readable throughout. . . . Prof. MacBride is to be congratulated on producing a book that will be indispensable to the senior student and any one else who wishes to become familiar with the facts and teachings of invertebrate embryology.”—*Science Progress*.

VOL. II

VERTEBRATA

WITH THE EXCEPTION OF MAMMALIA

BY

PROFESSOR J. GRAHAM KERR

31s. 6d. net.

“Prof. Kerr has rendered a great service to scientific students by the publication of this volume, a volume which undoubtedly will take a high rank among modern text-books of zoological science.”—*Nature*.

LONDON : MACMILLAN AND CO., LTD.

TEXT-BOOK
OF
EMBRYOLOGY

VOL. II.—*continued.*

“Professor MacBride, who wrote the volume on Invertebrates, carried out his work with complete success, displaying powers of clear exposition and a balanced judgment with regard to theory. Professor Graham Kerr’s systematic exposition of the facts is admirable, and, as he has been able to choose many of his examples from his own investigations, he has a right to speak with authority. The volumes are a great testimony to the exactness and comprehensiveness of British morphological science.”—*The Times.*

VOL. III

MAMMALIA

BY

THE LATE RICHARD ASSHETON, Sc.D., F.R.S.

Completed by F. H. A. MARSHALL, M.A., ScD.,
and J. T. SAUNDERS, M.A.

[*In preparation.*]

Crown 8vo. 5s. net. With Illustrations.

LECTURES ON SEX AND
HEREDITY

DELIVERED IN GLASGOW, 1917–1918

BY

PROF. F. O. BOWER, Sc.D., PROF. J. GRAHAM KERR, M.A.,
and PROF. W. E. AGAR, D.Sc.

“Excellent little book. . . . No one who has a natural interest in living things, but has had no systematic training in biology, can fail to find these lectures interesting.”—*Nature.*

“In these lectures the leading facts relating to sex in animals and plants are set out with a simplicity and breadth of view which should commend them to a wide circle of readers.”—*Journal of Education.*

LONDON: MACMILLAN AND CO., LTD.

