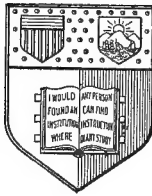


# The James Way





New York  
State College of Agriculture  
At Cornell University  
Ithaca, N. Y.

---

Library

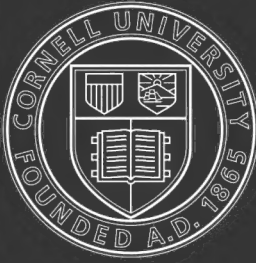
CORNELL UNIVERSITY LIBRARY



3 1924 051 998 809







# Cornell University Library

The original of this book is in  
the Cornell University Library.

There are no known copyright restrictions in  
the United States on the use of the text.

<http://www.archive.org/details/cu31924051998809>



*The*  
JAMES WAY

A book showing how to  
build and equip a practical  
up to date Dairy Barn

---

*Published by*

The James Manufacturing Co.  
Fort Atkinson, Wisconsin.

---

1919

72  
J3  
101-7

# The James Way

CATALOG No. 27.

**T**HIS edition is issued November 1, 1919, and is subject to change without notice.

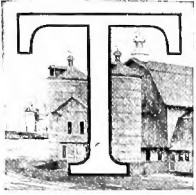
The James Manufacturing Co. reserves the right to make changes or improvements at any time without any obligation to install same on equipment previously sold.

For the convenience of readers, a complete index at the end of the book has been provided.

## JAMES MANUFACTURING CO.

Fort Atkinson, Wis.	Elmira, N. Y.	Fort Dodge, Iowa
Minneapolis, Minn.		Chicago, Ill.
Broadway and Ward Ave. N. E.		175 West Jackson Blvd.
New York City		Philadelphia, Pa.
101 Park Ave.		The Bourse Bldg.

# Foreword



HIS book is issued as a practical guide to him who is interested in or should interest himself in the better building and better equipment of barns—particularly dairy barns.

It has been the privilege of the James Manufacturing Company to originate sanitary dairy barn equipment ideas that make it easy to maintain the conditions of cleanliness in the stable required by law; equipment that not only helps in keeping the barn clean but effects great savings of labor, time and feed, forces cows to give more milk and prevents in many ways losses by accidents and disease.

How this equipment accomplishes such results is told in this volume. Whatever faults this book may have, I believe it has at least one merit—that every word in it is true. I know that there has been no intentional exaggeration or misstatement in any way. The facts are plenty good enough.

From the very beginning of this business, we have been called on by customers and prospective customers for information and advice, not only regarding the arrangement of the floor space, but also the design of the dairy barn throughout. In order that we might serve our customers, we early established a Barn Planning Department for the benefit of all who might be interested in the building of good barns. This Department has rapidly grown from year to year until it has now become a great clearing house of ideas relating to the improvement of dairy and other farm buildings.

As a part of this service we publish the following pages regarding dairy barn construction; not with any thought that these pages cover the subject comprehensively, but rather as a bird's-eye view of the general subject with specific suggestions on the more important points.

The subject matter and the drawings apply to the conditions in territory where cows are housed over night and in cold or bad weather; but we are also in position to advise as to barns in warmer climates.

If you do not find in this book the information you desire regarding barn construction, I hope you will feel perfectly free to write this Company or write me personally and we shall be glad to do what we can to help you solve your barn problems.

Experienced members of our organization make frequent journeys to various sections of the country. When letters asking for advice are received by us, it is often possible to have one of these competent men call in person, without expense to you, to help solve the barn questions that are troubling you. We are glad to do this whenever possible.

The business has now grown so large that I am no longer able to give personal attention to every detail; and if at any time you feel that you are not getting the service you desire, or if there is anything not entirely pleasing to



IRG CO.  
UIPMENT

JAMES MANUFACT  
SANITARY DAIRY BARN

OFFICE

Elmira, N.Y. Plant



you in your transactions with us, I shall appreciate it as a very real and personal favor if you will write me regarding it.

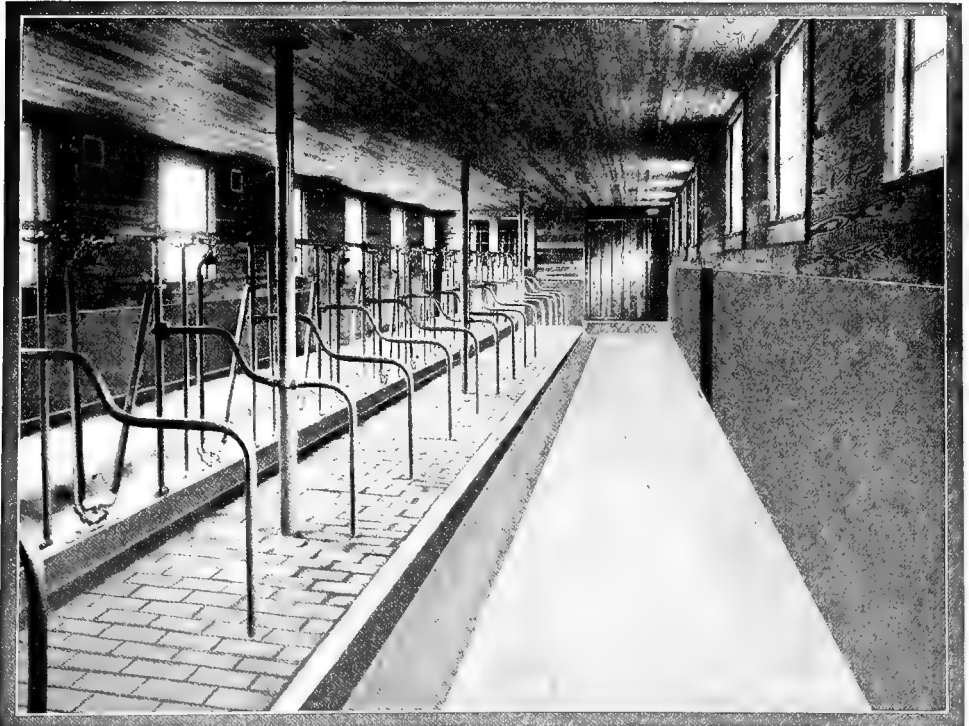
It is my desire, and the desire of every member of this organization, to be of real service in the betterment of dairy barn conditions. If we are not measuring up to our opportunity, we shall certainly appreciate criticism as a friendly act.

It is difficult to cover such a big subject thoroughly and satisfactorily even in a book of this size. Individual problems are oftentimes the most easily solved by personal consultation; and many dairymen, often from far away sections of the country, have told us that the information obtained by personally visiting our plant has saved them many times the expense of the journey.

I wish to extend a very cordial invitation to you also to visit our factory at Ft. Atkinson or at Elmira, and to assure you of a welcome when you come.

Yours very sincerely,

*H. James*

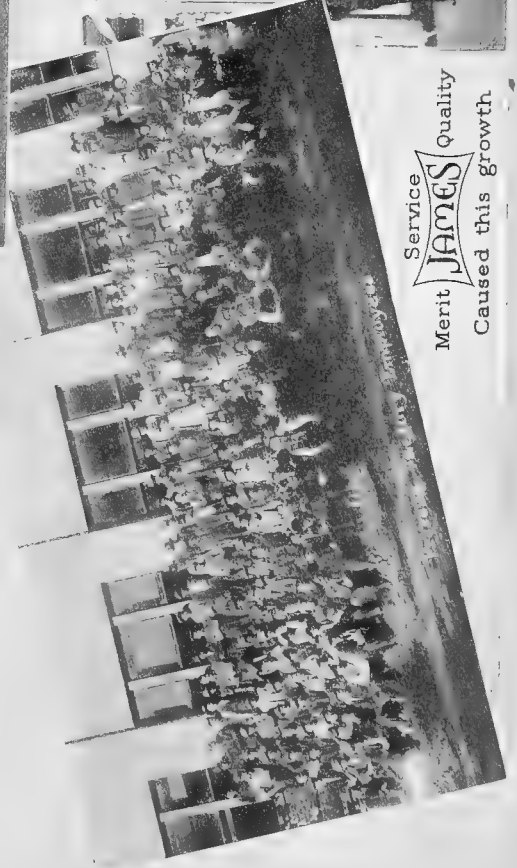




First building on site  
1906



Employees 1907



Employees 1914



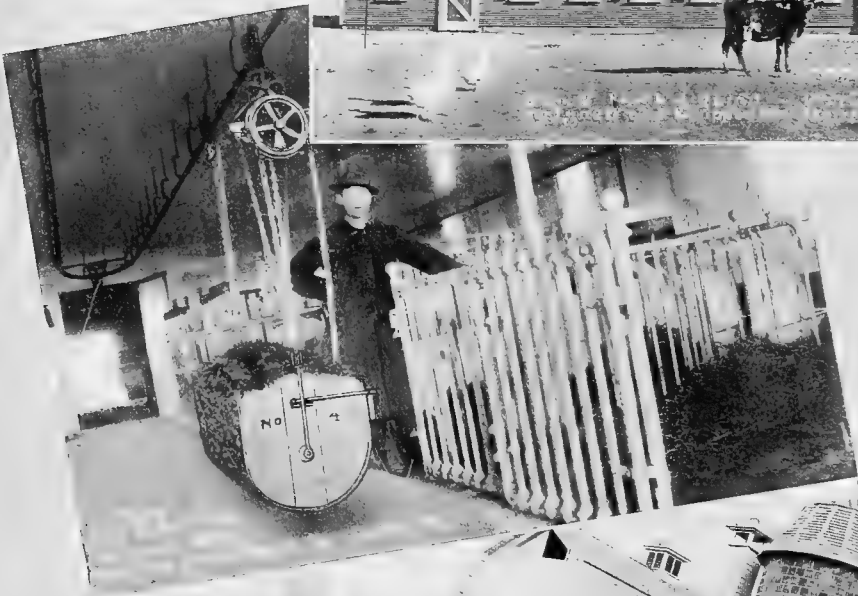
Officers and Office employees

Service  
Merit **JAMES** Quality  
Caused this growth





The Home Plant, Ft. Atkinson, Wis.

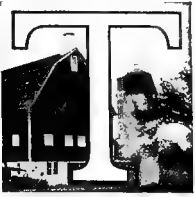


Barn of Borden Condensed Milk Co. Equipped the James Way.  
Racine Wisc.



Borden Condensed Milk Co. Equipped the James Way.

# Building a Dairy Barn



THE proper and economical erection of a dairy barn requires greater foresight and more careful planning than is usually given the subject.

The dairy barn is your factory—your workshop—in use almost daily throughout each year.

If the barn is not built right—if it is not correctly planned—it may result in losing money for you every day. A barn once built is not easily moved or altered in size, shape or arrangement; hence the vital importance of making certain that the barn is correctly designed before it is built.

Mistakes in building have a very unpleasant habit of forcing themselves upon a man's attention after it is too late to rectify them. The most thorough investigation, study and thought before building is necessary to forestall errors that would later prove extremely expensive.

Wrong location of posts—inconvenient arrangement of feed bins and feed rooms—incorrect arrangement of carrier tracking—or the wrong design of framing may compel you to take more steps, do more work, and pay out more money for help each day throughout the life of the barn.

A silo or a door in the wrong place—poor arrangement of equipment—ventilating intakes or outtakes improperly installed—mistakes in size of stall floors, gutters, passages and alleys—even these small items may be a source of daily expense.

A barn correctly designed and built is right in every little detail—it is a constant money maker, because it will save time, labor and feed each day.

It will add to the value of your farm, and get you a better price for it when you want to sell, for the average farm buyer looks at the improvements first. The farm with a convenient, practical barn will sell at a higher price than another farm of equal fertility, with a more costly but inconvenient and poorly arranged barn.

The right plans will not only give you a better barn from the standpoint of looks, from the standpoint of convenience in handling the daily chores, and in comfort for the cows—but it need cost you no more than the same size barn poorly designed and inconveniently arranged.

A good stable also adds to the selling value of your cows because it shows them off better, makes them healthier, finer looking, and better producers.

If you intend to build a new barn or remodel an old one, you are, of course, anxious to avoid the expensive mistakes of poor plans, carelessly and hastily made.

This can only be done by studying the entire matter carefully for yourself, and getting all the suggestions and help you can from others who have had wider experience in the planning of dairy buildings.



Our Barn Planning Department has not only designed hundreds of the practical dairy barns of the country, but thousands of barn plans are being submitted to them yearly for their criticism and suggestions. Because of this wide experience, some of the things we have learned regarding barn building may be of interest and help in the planning of your barn. This book is published in the hope that it may help you and other dairymen to secure better barns for the money you have to invest.

There are many points on which dairymen differ with regard to barn construction—differing conditions of climate, territory and purpose, making each barn almost an individual proposition.

The barn that meets the needs of one man in Wisconsin may be totally unsuited to the requirements of his next door neighbor or to the needs of a farmer in Tennessee.

The amount of money available for building, the kind of dairy farming to be carried on, the site, character of building materials most convenient, and many other points known only to the owner himself, require consideration. Nevertheless, there are certain fundamental conditions common to most dairy barns, and with the above in mind it is our purpose to give general information that is most interesting to prospective builders.

## Fundamentals

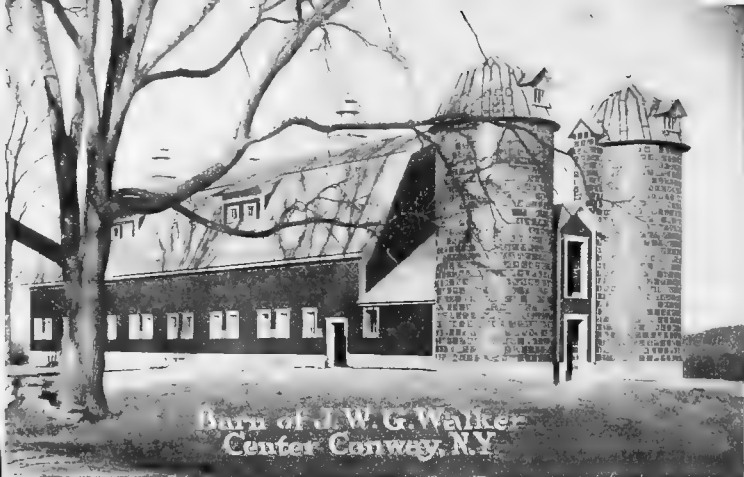
In order that the dairy barn may become as big a profit maker as possible, certain fundamental elements must be remembered. The most important items to be considered are cleanliness; cow comfort and cow health; convenience for the workman in handling the daily chores, and economy of construction.

The dairy barn is a place where human food is produced. For the protection of the public health, and for the well-being and comfort of your cows—as well as to meet the requirements of those who buy your products—the first great essential to be kept in mind is cleanliness.

By use of the proper construction, and by carefully planning the arrangement of the stable, this point may be cared for without excessive increase in cost of building, or in cost of operating the plant.

Since contented, healthy cows produce more milk, the things that please the cow and insure her health and comfort must likewise receive thoughtful attention.

If the arrangement of the barn is planned rightly, plentiful lighting, abundant ventilation and easy disposal of the litter will be provided—all floor space will be used economically and to the best advantage—and the number of steps necessary in doing the daily chores will be reduced to the minimum.



Barn of J. W. G. Walker -  
Center Conway, N.Y.



Concrete Yard - Barn of  
Dennis Ziegler, Waunakee Wis.



Sheltered on the summer



Sheltered Yard - Barn of  
Dr. Enoch Perry, Harsha, Wis.

In many a case careful planning has cut the labor of caring for the cows squarely in half, at the same time keeping the stock cleaner, healthier, more contented, and the barn in a more sanitary condition.

### How to Build Most Cheaply

To secure these desirable results the cost of the barn need not be extravagant; what the building will cost depends more than all else on the care with which it is planned in advance and the thought that is given to the actual construction. In our experience it has been no uncommon thing to see one man with the "know how" build a barn *at 20 or 30 per cent less cost than another*, although the barn accommodates the same number of cows; and *the first gets a handsomer building, more convenient and better arranged*.

Regardless of who designs the barn, it is well to submit the final plans to several contractors, getting bids from each. By having as many sets of blue prints and specifications as there are contractors figuring on the barn, you can safely let the contract to the lowest bidder, because the successful bidder must follow directions as to workmanship, construction and material.

### The Site

Even before plans are drawn, the exact location of the barn should be decided, because the site chosen may alter the plans considerably.

The barn should, if possible, run north and south, as this will permit sunlight to reach all points within, at some time during the day. Sunlight is the best of all disinfectants—the easiest and most certain method of destroying germs of tuberculosis and other diseases.

The barn should be so located that a sheltered yard may be provided to the south of the building.

Consideration must also be given to the appearance from the highways; the position of surrounding buildings; and the location of hills, trees and hedges for windbreaks. Where there is more than one barn the buildings should be arranged as conveniently as possible, to lessen the labor of caring for the stock.

The location should be such that the yard will have natural drainage or can be so graded that the surface water will run away from the barn. A cow will keep herself fairly clean if given a chance, standing in filth only when compelled to do so to secure food or water or protect herself from flies. If the yard is kept dry and clean it will make much easier the task of keeping the cows clean, as well as promote the health and comfort of the cattle.

Many farmers are solving the barnyard problem by covering with six inches of broken stone, placing cinders or gravel on top, a little slope being



Dairy Barn Equipped for Economy  
University of Wisconsin  
Creamery and Dairyery



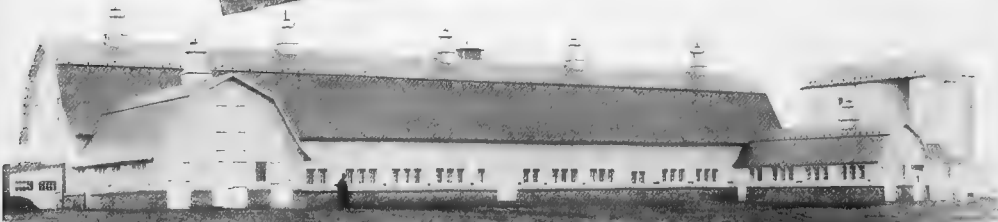
Barn of E. D. Howe  
Marquette, Me.



Friends Hospital, Boston, Pa.  
Designed and Equipped the Same Way



Barn of Dr. Erach Howe  
Hingham, Wis.



How this Barn was Built without Partner Windows  
Friends Hospital, Boston, Pa.  
Designed and Equipped the Same Way



given to provide drainage. Occasionally a barnyard is seen that is made of concrete, which has the great advantage of being very easy to keep clean.

### Size of Barn

The next thing to be determined is the size of barn needed to accommodate the animals and provide the necessary storage capacity.

Experience has proven certain measurements of stalls, mangers, gutters and passageways to be the most practical. With these measurements and information as to present and prospective size of farm, kind and number of head of stock, system of farming and number of acres in crops, the size of barn required can be quickly figured out.

In almost every case the most satisfactory results are secured by placing the cows in two rows; in the average barn the stalls, gutters and alleys make thirty-four feet inside the most convenient and practical width. For certain purposes the barn is sometimes made slightly wider, but with few exceptions thirty-four feet is best.

It is quite true that this width is not the most economical when the relation of wall space to floor is considered, but any loss in this direction is more than made up in the ease with which the stable work can be performed. The two-row arrangement also permits better ventilation and better lighting.

Individual circumstances must determine whether the barn is to be one-story, a story-and-a-half, or full two stories. The one-story barn is often preferred where barns already built are to be used for storage purposes. The story-and-a-half type provides considerable storage room, particularly if baled hay is used.

The full two-story barn gives far greater storage capacity in proportion to cost.

Roof, floor and stable walls cost practically the same whether the building be low or high, and about the only additional expense to secure the greater capacity is the cost of the second-story walls, which is comparatively small.

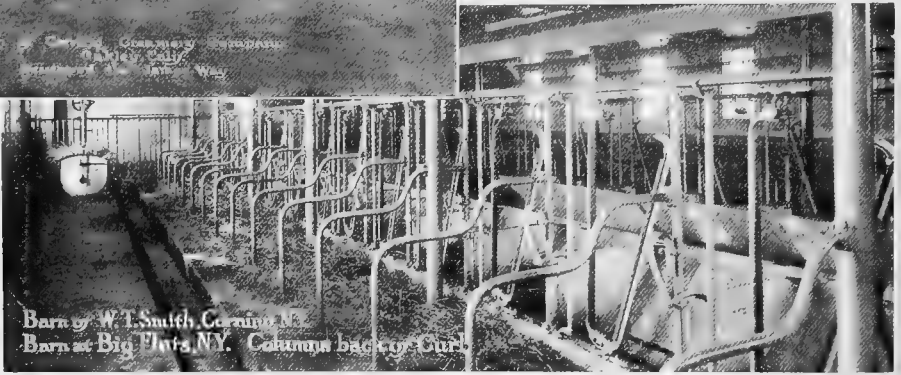
A tight ceiling in the stable does away with the principal objection to storage above the cows.

### Appearance of the Barn

Barns can be well designed, good looking and practical without additional expense. Such barns will add to the attractiveness of the farm, and make it worth more to any prospective purchaser.

Correct designing—the right lines—has more to do with the pleasing appearance of the barn than any other one thing, although the exterior finish and the relation of other buildings must be considered.

Properly proportioned dormer windows break the monotony of the roof, and add greatly to the appearance of the building.



These dormers also serve the more important purpose of giving light and ventilation to the haymow. You know what it is to mow hay on a hot summer's day, and can readily appreciate the value of ventilation and light in that part of the building.

The ventilators can also be made to add to the appearance of the barn if they are correctly designed, and they can be made to aid in the ventilation of the mow, as well as of the stable.

## The Walls

The average height of the stable ceiling should be from eight feet six inches to nine feet, at the walk behind the cows. Of course, as the floor is usually built, this means that the height will be about ten inches less at the feed alley.

A greater height than nine feet calls for more heat to keep the stable comfortable, and is of no advantage in other ways.

As the dairy section extends from the warm south to the cold northwest, the construction should be modified to meet conditions.

In the south, a wall of one layer of siding, tongued and grooved, or battened, is sufficient for warmth, while at the northern extreme, one or more dead air spaces are needed. The barn must be planned according to the climate.

In the south, barns may be built without wooden sides, canvas curtains being provided to keep out the little chill that is sometimes present.

On the other hand, it is almost impossible to keep the stable on the Dakota prairie sufficiently warm when a blizzard is blowing.

When building a concrete basement, the door header should never be placed lower than the mudsills. To do so might make it difficult to put in a carrier outfit, excepting by breaking out the concrete so as to allow the track to pass.

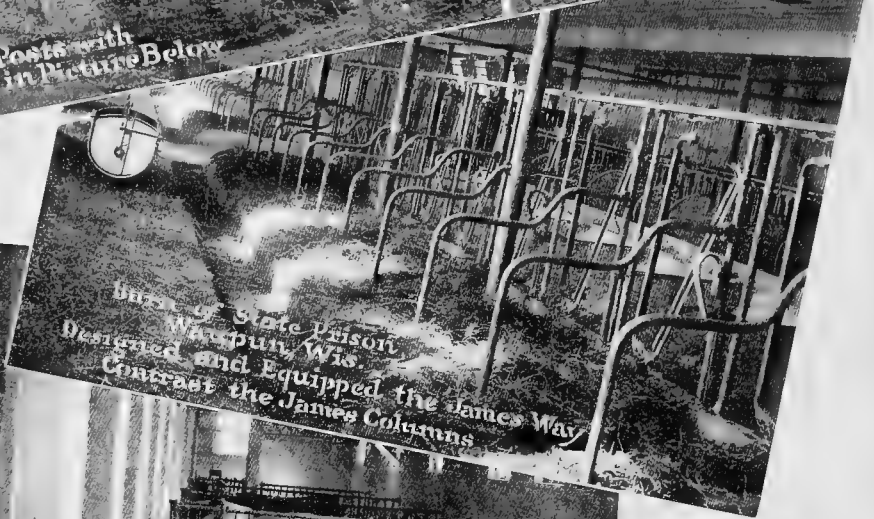
## Posts or Columns

In the planning of the barn, one of the most serious considerations is the arrangement of the posts or columns. These should always be located about six inches in the clear back of the curb, in line with the stall partition; or else just back of the partition.

If a post is located in the stall frame, it interferes with the proper construction of the cement curb; if ahead of the stall frame it interferes with the manger or the alley; if located other than in a line with the stall partition it takes up room out of the stall.



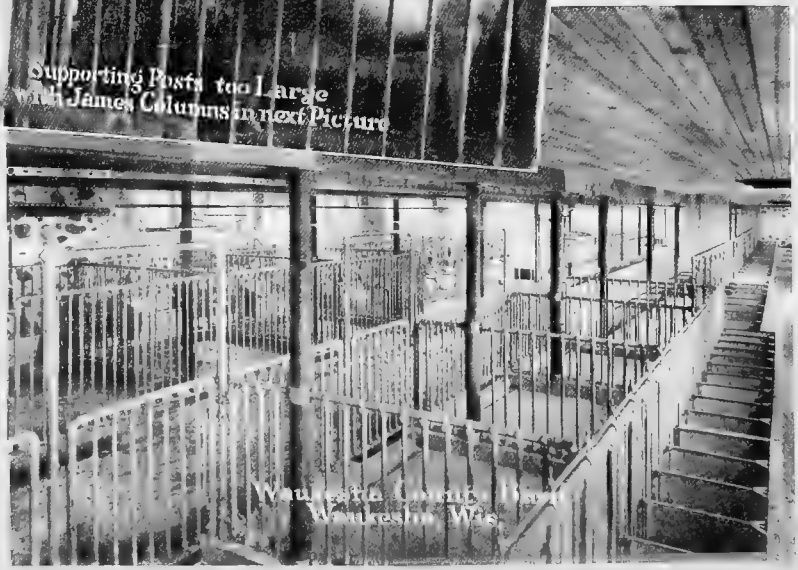
Contrast Posts with Columns in Picture Below



Interior of State Prison  
Waupun, Wis.  
Designed and Equipped the James Way  
Contract the James Columns



Supporting Posts too Large  
Contrast with James Columns in next Picture



Waukesha County Jail  
Waukesha, Wis.

A post six inches back of the stall frame does not interfere with making the curb; or just back of the partition does not interfere with the installation of the equipment.

Dairymen and farmers are finding the James Steel Columns (filled with red granite, torpedo washed sand and Portland cement) far better supports for the barn than wood.

They occupy one-third the space, are fireproof, interfere less with light and with the circulation of air, are neater, more up to date in appearance and are more durable, costing less in the long run than wood. There is absolutely no objection to columns in the stable, providing they are properly located. Columns are less expensive than the trussing required if they are dispensed with—at the same time they leave the haymow clear of obstructions.

The 4½-inch James Column for example, has a safe carrying capacity equivalent to an oak or yellow pine post 6 in. x 8 in.; or a white pine post 8 inches square.

A 4½-inch James Column has a cross section area of 15.9 sq. in. as compared with 48 sq. in. cross section of the oak or yellow pine post, or 64 sq. in. of the white pine post referred to in the above paragraph.

Thus it will be seen that the James Column of equal strength takes practically only one-fourth to one-third the space occupied by the wood posts.

## Stable Floors

A good stable floor should be impervious to water that it may be sanitary; it must be easy to clean; comfortable for the cow; and durable in service. It should not rot nor wear out, nor be expensive to construct.

The old-style wood floor had the merit of being warm and easy on the feet of the cattle. It is long since out of date, however, because it soon gets foul, rots out quickly, and becomes unsanitary; is high in first cost; and its life is short—three to five years being the usual life of a wooden floor.

The two materials now widely used for stable floors which can be recommended are concrete and cork brick.

Concrete floors have proven very satisfactory in most ways, meeting every requirement for the dairy barn floor, with one exception—it has been found injurious to cows to stand or lie on its cold, hard surface.

The problem is solved by using concrete for the entire floor, covering the stall floor with cork brick, the cracks being filled with cement. The surface is easily kept clean, is impervious to moisture, warm and easy on the feet of the cattle.



Banks, Traverse City  
State Hospital Mich.  
Equipped the James Way



## Material for Concrete Floors

The dirt floor of the stable should be as level as possible, thoroughly tamped and well wet, so that no settling will occur.

It is advisable, before laying the concrete, to spread a foundation of porous material, such as gravel, cinders or sand, evenly on the surface and thoroughly tamp. The depth of this porous foundation will depend upon the drainage of the soil. Where a fill of earth has been provided, this foundation need not be more than four inches thick.

## Thickness of Concrete Floor

The usual thickness of a stable floor is four inches concrete grout with  $\frac{1}{2}$  inch to 1 inch thick facing on top of the concrete grout.

## Proportions of Materials

A mixture of one part of Portland cement, two and a half parts sharp, coarse, clean sand, and five parts coarse, clean gravel is used; for the upper  $\frac{3}{4}$ -inch facing one part of Portland cement, two parts sharp coarse clean sand. No loam, dust, vegetable matter or clay should be allowed in the material, as it tends to form a layer over the face and keeps the cement from binding it into a solid mass.

## Mixing the Concrete

The water used should be fresh and clean, free from any acids or strong alkalis. The water should not be put in the mixer with a hose, but should be measured, and when the proper consistency has been found, use exactly the same amount for each batch.

The concrete should be mixed in batches. All materials should be first thoroughly mixed dry, after which the water is added and the mixing continued until the concrete is uniform.

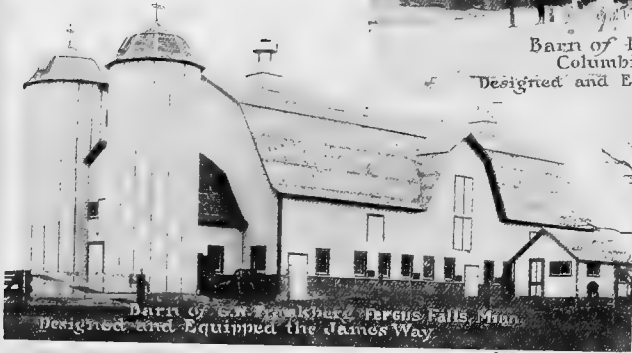
## Gutter

A properly constructed gutter is very essential to insure strict sanitation. It should have vertical sides, at least four inches deep, to break the spatter, and make it easy to clean with an ordinary shovel. The size of gutter which has proven most satisfactory is sixteen inches wide, six or seven inches deep on the stall side and four inches deep on the other. Often the alley back of the cow is pitched just a trifle, so that the liquid manure and flushing water will run back into the gutter.

Mangers and gutters should be provided with drainage, to be used only for washing out—never for the purpose of removing the manure.



Barn of D.V. Whiteleather  
Columbia City Ind.  
Designed and Equipped the James Way



Barn of S.W. Frankburg, Ferris Falls, Minn.  
Designed and Equipped the James Way



Barn of John L. Last, Last, Pa.  
Equipped the James Way



Wm. F. K.  
Charlie M.  
Equipped the James Way



Barn of S.P. Stevens, H. S. Pitt



Most dairymen now consider it the best practice to preserve the fertilizing value of liquid manure by the use of absorbents, such as cut straw, shavings, etc.

The method of handling liquid manure by draining into a cistern is no longer considered favorably, because of the difficulty in handling.

## Plank Frame Barns

There are many types of dairy barns, with many modifications of each type. But of late years the plank frame barn, in one form or another, has become the most popular.

Since its construction is not as well known as some of the other types, we are devoting space to this special class of buildings. The principal reasons for the building of the plank frame barn are:

1. The fact that it saves in cost of lumber.
2. It provides far more storage room in the hayloft.
3. Is much more easily built than any other type, if the correct method of erection is followed.

In building the plank frame barn, ordinarily no piece of timber is used thicker than two inches. Girders, trusses, purlines and tie plates are built up of two or more  $1\frac{5}{8}$ -inch to 2-inch planks, four to twelve inches wide if barn is not wider than forty feet.

With the scarcity of heavy timbers and their consequent high cost, it is worth while for farmers to study this newer method of framing.

With the old-style heavy timber framing, the cutting of the mortise and tenon joints required much skill and labor. Since a truss, like a chain, can be no stronger than its weakest point, many of the heavy timber frames are not as strong as they may appear—the joints being only as strong as the thickness of the timber in the tenon.

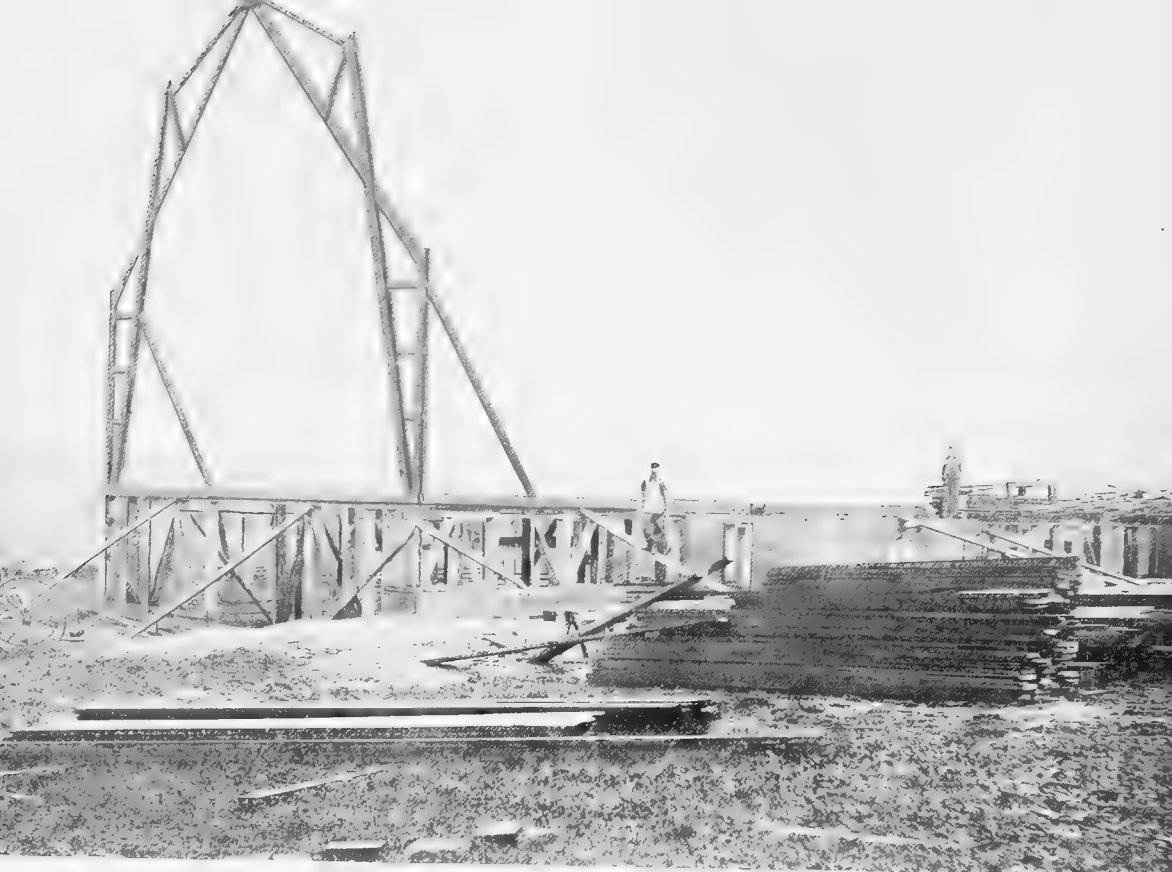
The girders built up of planks retain the full strength of all of the timber, and are as satisfactory as the solid timber girders of the same area.

The use of modern hay carrying machinery calls for barns with open centers. In the plank frame barn there are no cross beams nor heavy supporting timbers to interfere with such machinery.

With this style of framing one man can do as much work in mowing away hay as three with the old-style frame, there being no obstructions to interfere with and delay the work and it not only requires less help to put the hay into the barn, but it requires less labor to take it out.

This open loft also provides far more storage space.

The photographs and blue prints herewith should make the method of building the plank frame barn quite clear; and if you could see such a barn



in process of construction, you would realize that this type of barn is so easy to build that a skilled carpenter is hardly required to do the work.

H. A. Bennett, Ridgewood, N. J., writes: "We have built a dairy barn from the plans which you prepared for us, and must say that we are well pleased with the plank frame barn; the erection of it was very cheaply done as to labor, and we saved lots of heavy lifting, besides the economy in construction of the plank frame cannot be compared with the old heavy timber frame."

No scaffolding of any kind whatever is needed, and if the right method of raising the trusses is followed, no difficulty will be experienced.

The first step, of course, is the excavation for the foundations, and good practice requires that this extend below the frost line.

Sometimes the first story is built of concrete or stone. Where this is done, the ventilating intake flues may be of tile or galvanized pipe, set in place and the concrete poured or the stone laid around them.

Many object to the concrete wall, however, on the ground that it transmits too much moisture. It is also somewhat more difficult and more expensive to set window frames and intake flues in the stone wall than in frame construction.

The way preferred by many is to build the foundation of tile, stone or concrete to the window bases, completing the first story with a frame wall—2 x 8s or 2 x 10s forming the studding up to the ceiling. With such a wall it is easy to set in the window frames; and the space between the studding gives room for the proper installation of the ventilating intake flues, tapping the outside for the register face, and the inside for the complete register.

By using the joists or other timbers for the concrete forms, the cost of lumber for this special purpose can be saved.

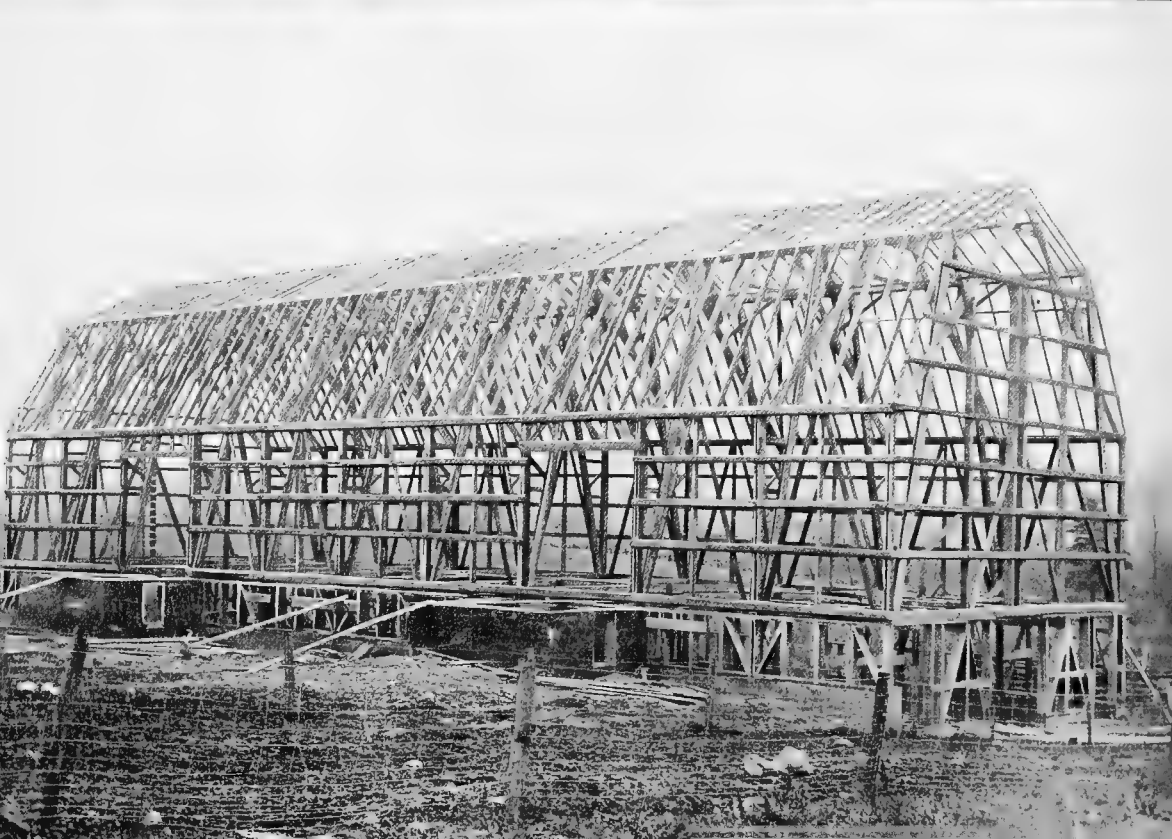
Experience makes it clear that where anything but tile or wood is used for the wall or foundation extended to window level, it must be furred out to give the necessary dead air space. Only in this way can such walls be made satisfactory.

After the foundation is in and the frame for the first story wall completed, the columns are next put in place, the proper footings for same having been provided. It is important that the footings be of ample size; if they are not, the building may settle, cracking the concrete floor and doing other damage.

Steel columns being used, the bottom of the column should be two to six inches below the finished floor line, depending on the method of finishing the floor. When these columns are in place the girders may be laid.

As suggested before, there are two kinds of girders—one of solid timber, the other continuous built up from two-inch planks.

The latter are usually preferable, being stronger because any defects in the lumber are apt to be better distributed. Care must be used to so stagger



the joints that the girder has uniform strength; the spacing of the joints depending on the distance between supporting posts and on certain other conditions.

The foundation, the frame of the first-story wall, supporting columns and girders all being in place, the floor joists are next put in.

Then a temporary floor of loose boards is laid on the joists, so that the workmen can move about freely while raising the trusses into place.

The plans will show exactly how to cut and put the first truss together—which will look like Illustration 1, page 26. When this first truss is completed, it may be laid out on the floor, and all the other trusses may then be built exactly like it, one on top of the other, thus insuring absolute accuracy.

When all the trusses necessary have been finished, the first truss is placed in position at one end of the barn.

This is usually done by placing the feet of the truss at the places where they are to rest when in position; with the top of the truss toward the center of the barn. Blocks are then spiked to the joists at the proper points, so as to keep the feet of the truss in place while being raised; the feet of the truss resting against these blocks and pivoting on them.

A gin pole (shown in Illustration 3) is erected at the end of the barn in the center, leaning at an angle of about 45 degrees toward the center of the barn; a block and tackle is rigged, the rope passing over the gin pole and attached to the upper parts of the truss. A horse or team is hitched to the block and tackle, and the truss quickly raised to position.

A gang of men can do the same work, but the horse or team is cheaper. A few men with guy ropes are necessary, to steady the truss while being raised.

As soon as this first truss is up, it is braced in position temporarily, as in Illustration 1. The second truss is then raised in like manner, and as soon as it is up the girts are added, as shown in Illustration 2.

Then one after the other the trusses are put in place, the girts being spiked on as you go along. The last two trusses, when laid in position for raising, will project over the end of the barn. The projecting portion is supported by temporary props, which are removed when the truss is being raised. The end girts can be added at any time convenient.

How much simpler than the old-time barn raising, when heavy timbers were in common use. No longer is there need for getting together thirty to forty men for the raising of a medium-sized barn! Today, a half-dozen men will put up the plank frame in less time than thirty or forty could in the old days.

To put on the plates no scaffolding is needed, since it is not difficult to climb up on the truss itself.

Next the purlines are put in place, raised to position with block and tackle.



Barn of William J. Smith  
Linn, Wis.



Barn of Elmer  
Roberts, Wis.



Barn of John Cramer, Monona, Wis.

Before putting on the rafters and cornice, the siding is nailed on; it can be done more conveniently before the rafters and roof boards are in place, there being nothing to interfere with nailing on the boards under the cornice.

### Light

The manner in which a barn is lighted is of importance. A dark barn is bad in several ways. The most important objections are, that it is difficult to keep clean, and is unhealthful. Make the barn sunny, for sunlight is Nature's greatest disinfectant, and of material assistance in keeping the cows healthy. There should be an abundance of windows.

As a rule, four square feet of glass should be provided for each animal in the barn. In cold climates, the windows should be a single sash of what is known as double-glazed windows. Do not run windows crosswise. The vertical window is far preferable.

With a rectangular barn, it is well to have the long way north and south. This will admit more direct sunlight to the stalls for the greater part of the day. Windows placed in the north side of a barn are of little service, for they admit no direct sunlight, which is necessary to destroy bacteria. South windows are always excellent, but, unless numerous, do not admit so much light to all parts of the barn as when placed on both east and west sides.

The position of windows is a matter of importance. Buildings with thick walls require larger windows to admit the same amount of light. It is best to place windows the long way up and down, for they will admit more light than when placed horizontally. They should be flush on the inside, to prevent accumulation of dust.

A single-sash window hung at the bottom is more practical than the double-sash, as the single-sash window can be dropped at the top, and the air as it enters is forced to the ceiling, thereby preventing drafts.

### Silos and Silage

Sizes.—As a matter of convenience in helping select the size of silo required, we give below, list of regular sizes the capacities, and number of stock that can be fed.

Dimen- sions	Tons Capacity	No. of cows it will keep for 6 mos., 40 lbs. per day	Dimen- sions	Tons Capacity	No. of cows it will keep for 6 mos., 40 lbs. per day	Dimen- sions	Tons Capacity	No. of cows it will keep for 6 mos., 40 lbs. per day
8x20	19	4	12x24	50	13	14x30	83	23
8x24	22	6	12x26	54	14	14x34	93	26
10x20	28	7	12x28	57	15	16x22	81	23
10x22	31	8	12x30	60	16	16x24	86	25
10x24	34	9	12x34	68	19	16x26	95	26
10x26	37	10	14x22	62	17	16x28	102	29
10x30	43	12	14x24	67	19	16x30	108	31
12x20	40	11	14x26	72	21	16x34	110	31
12x22	45	12	14x28	78	22	16x38	122	33



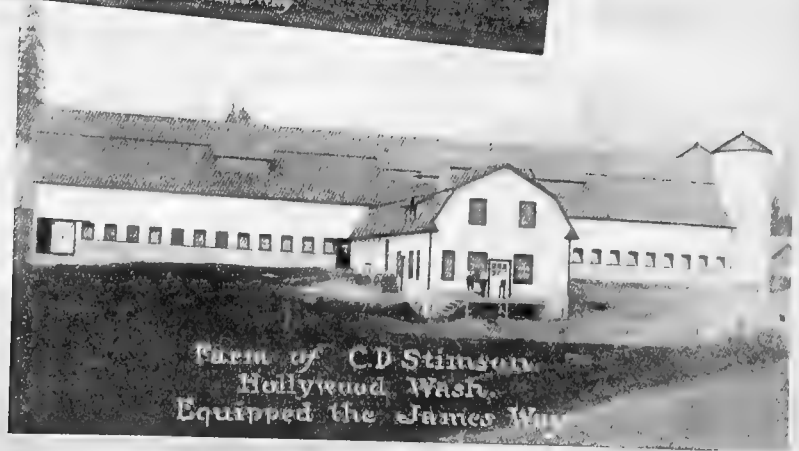
Equipped the James Way



Hog Barn at Broad Lawn Farm  
Newtown Square, Pennsylvania  
Equipped the James Way

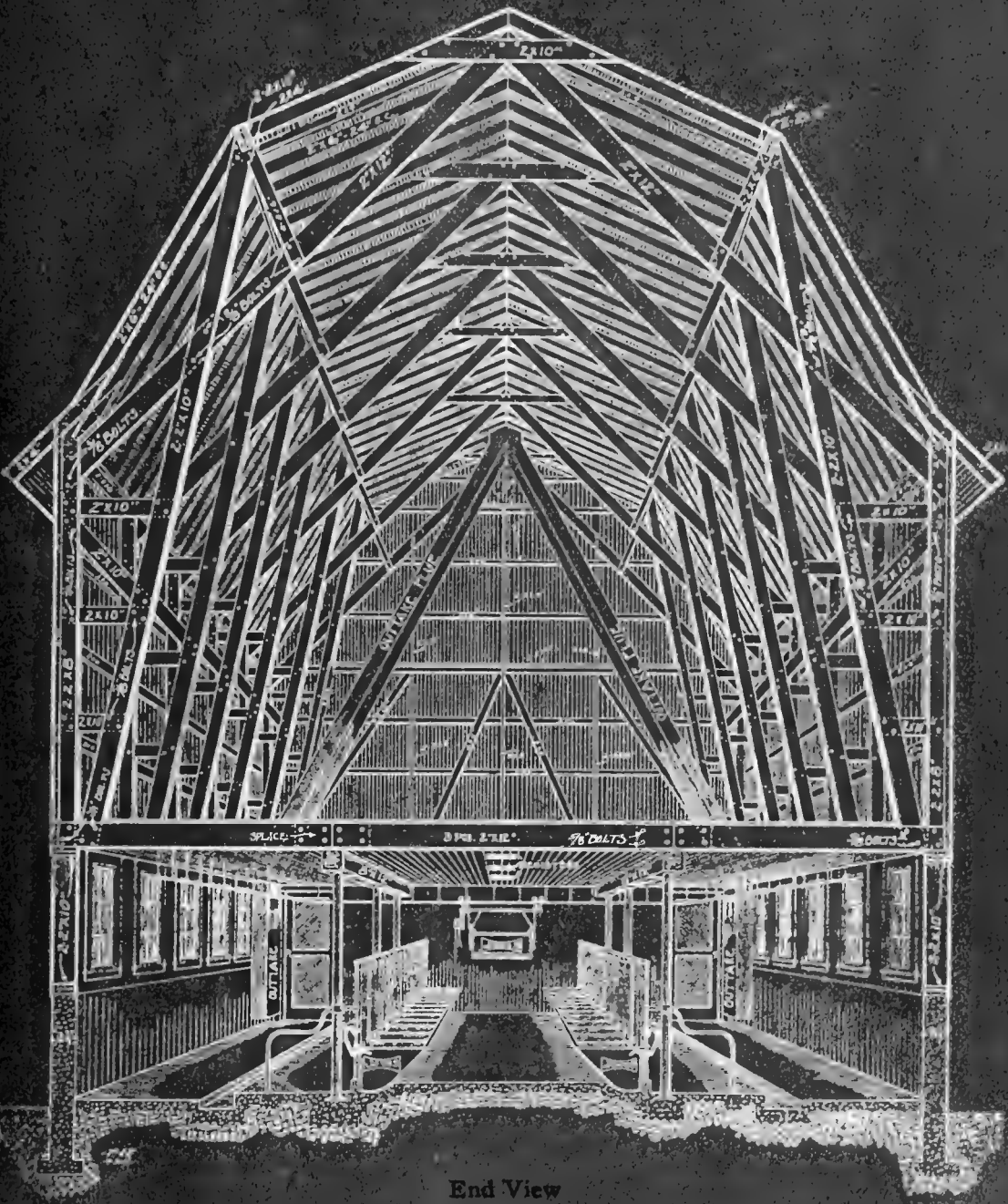


Equipped the James Way



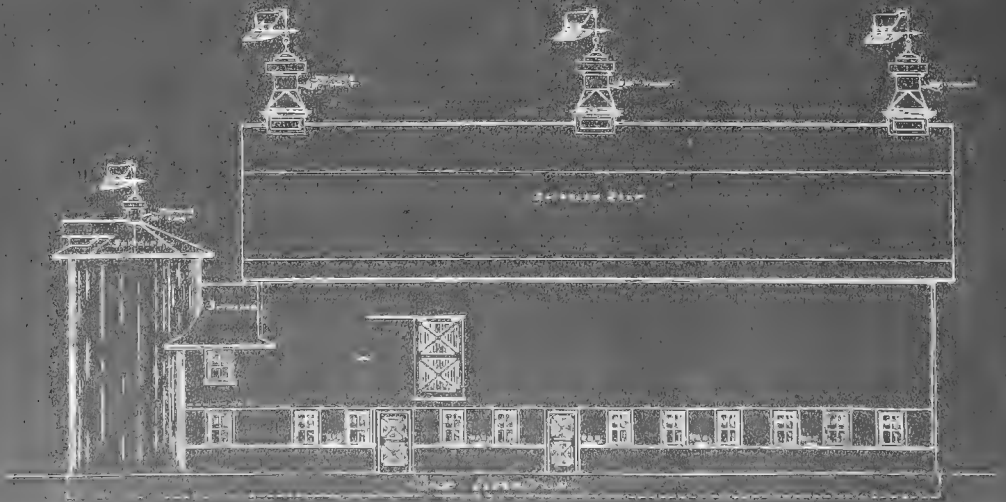
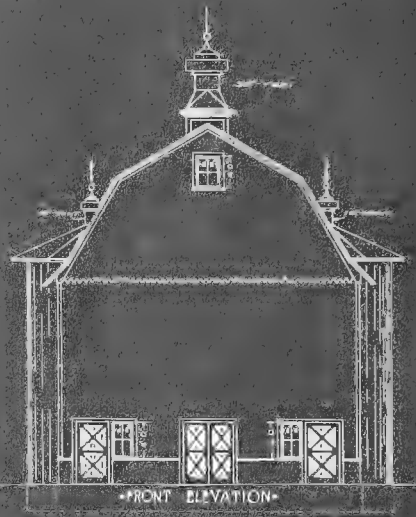
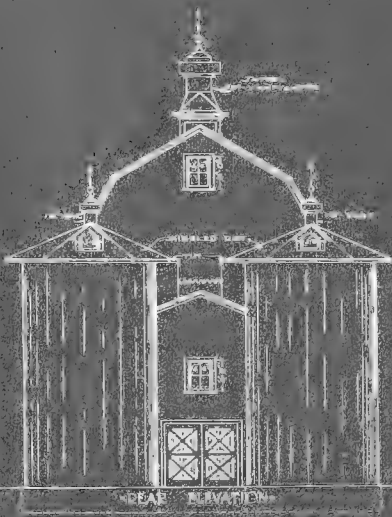
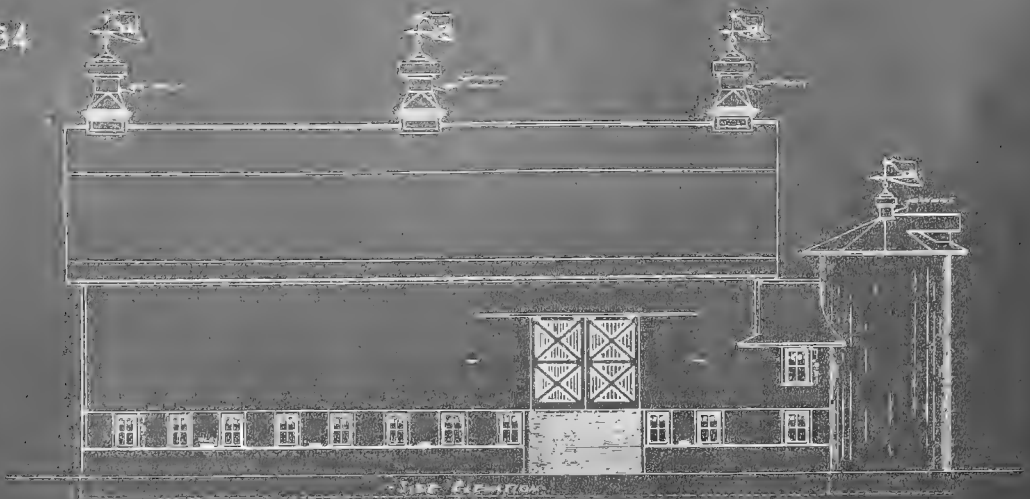
Farm of C.D. Stinson  
Hollywood Wash.  
Equipped the James Way





End View

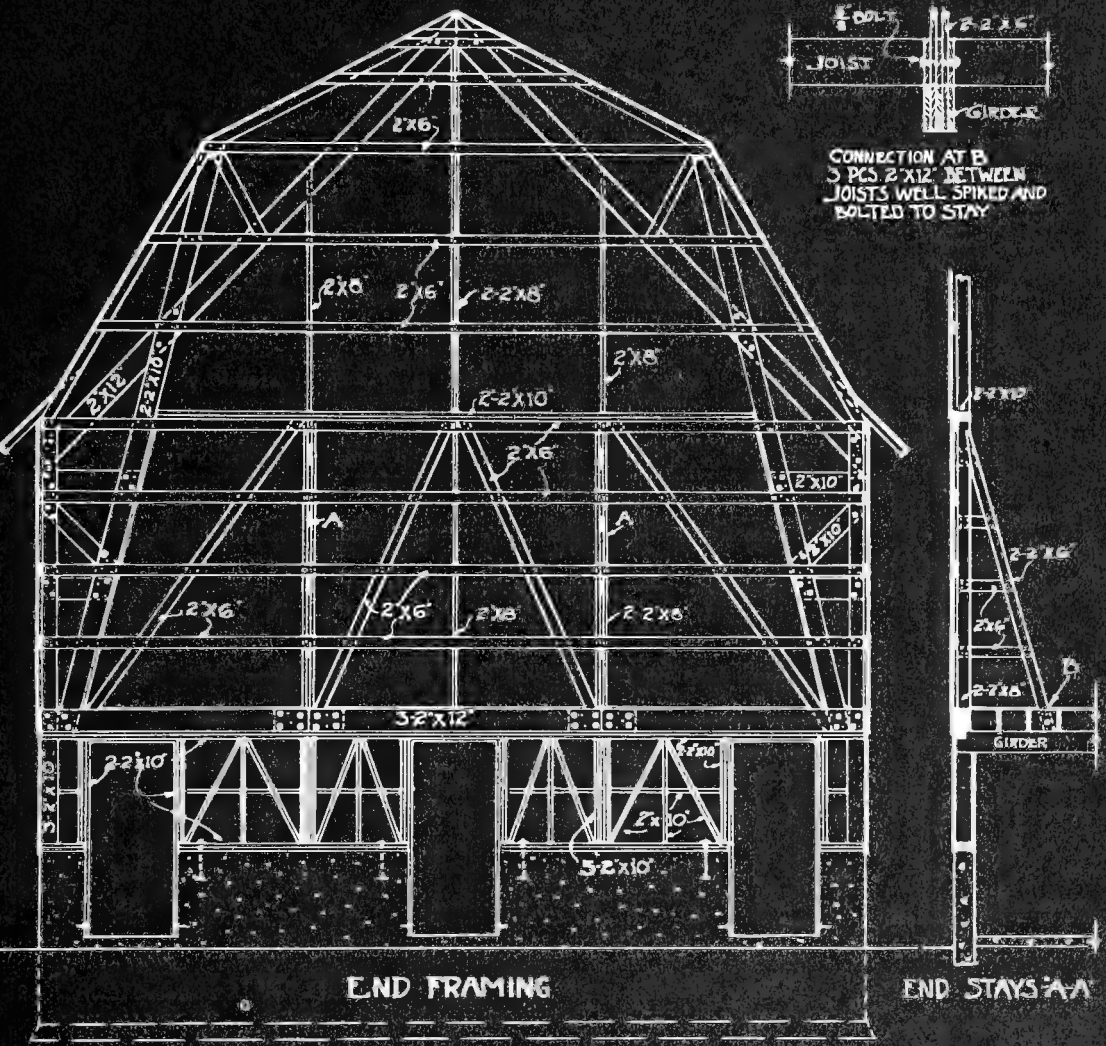
Plank Frame Construction



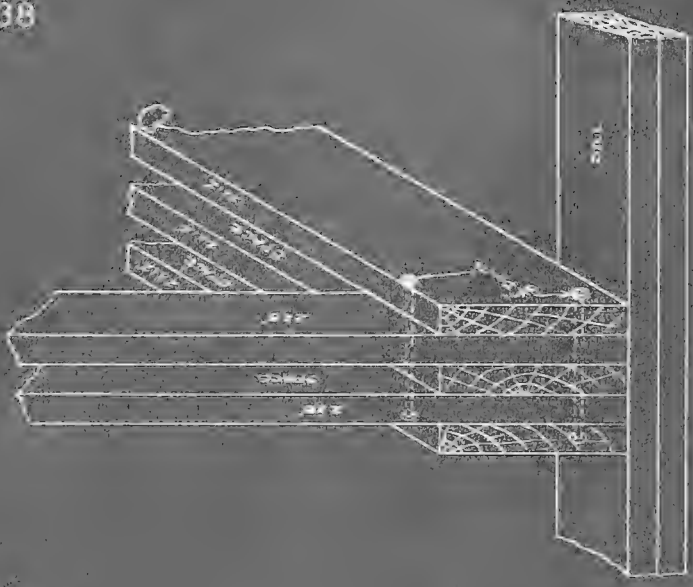








Plank Framing

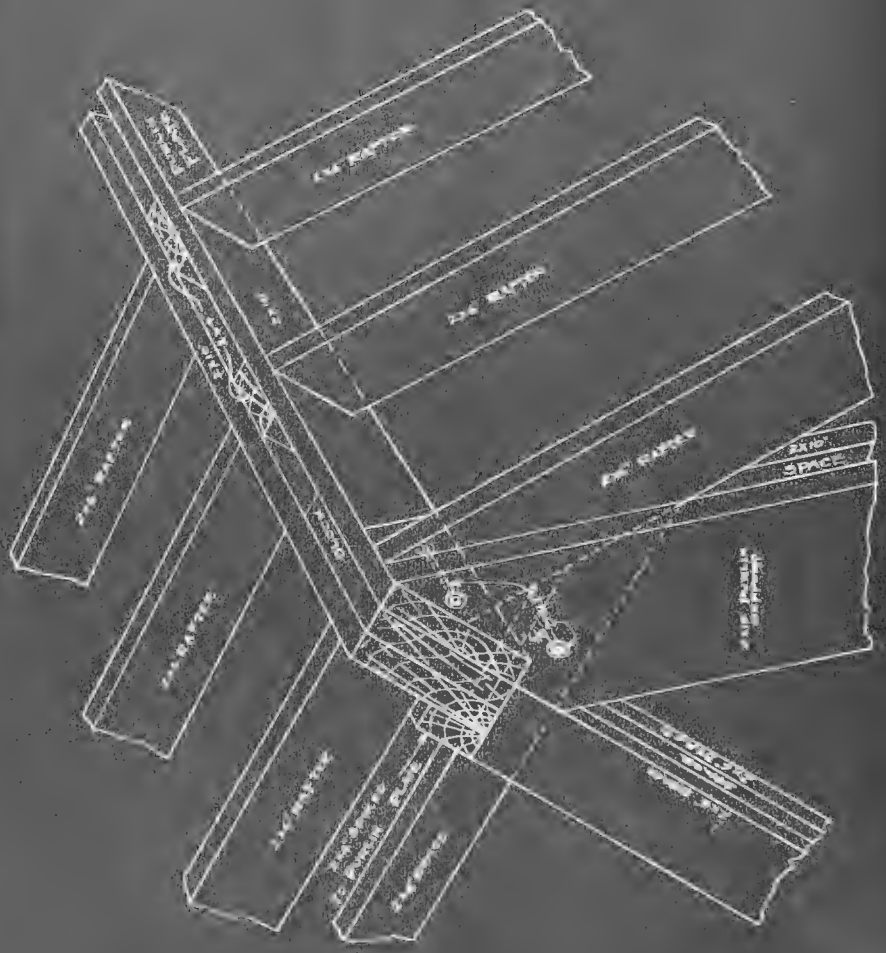


DETAIL OF THE PLATE AT  
BOTTOM OF TROUSSES

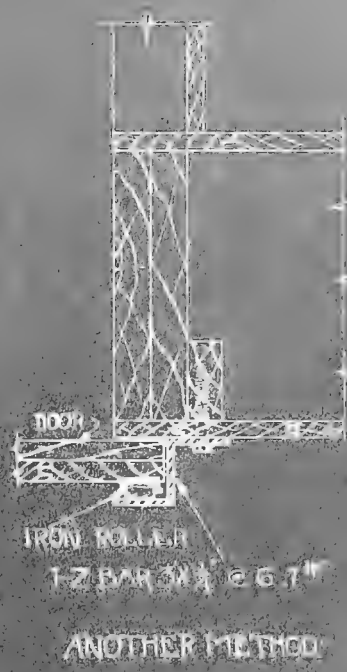
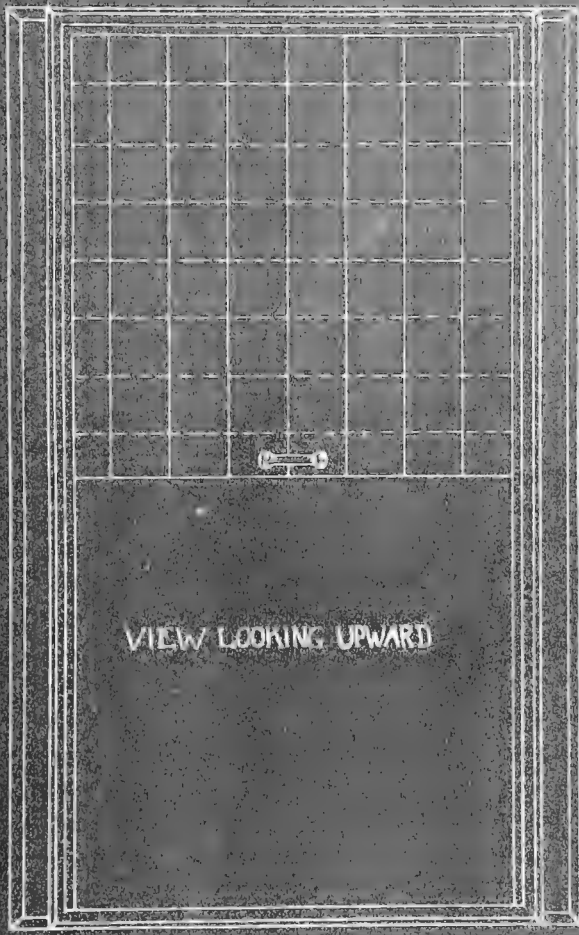
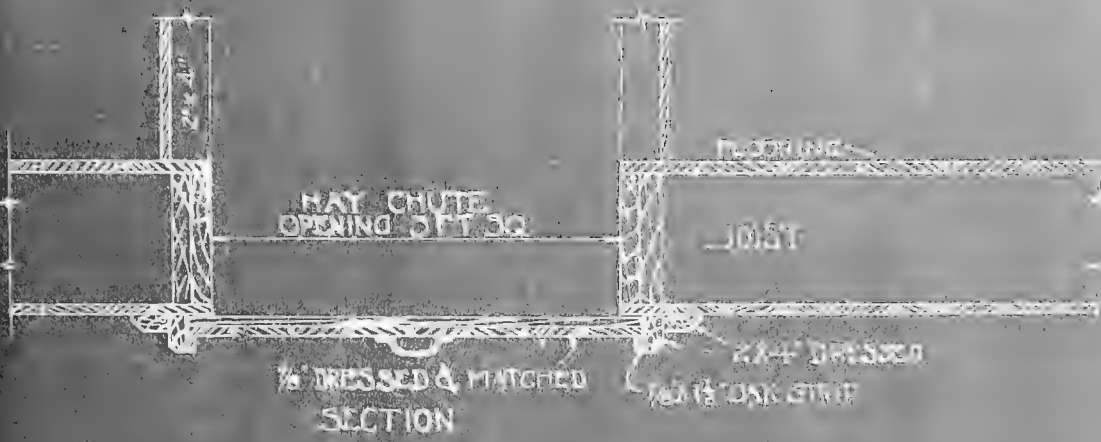
For Plank Frame Construction



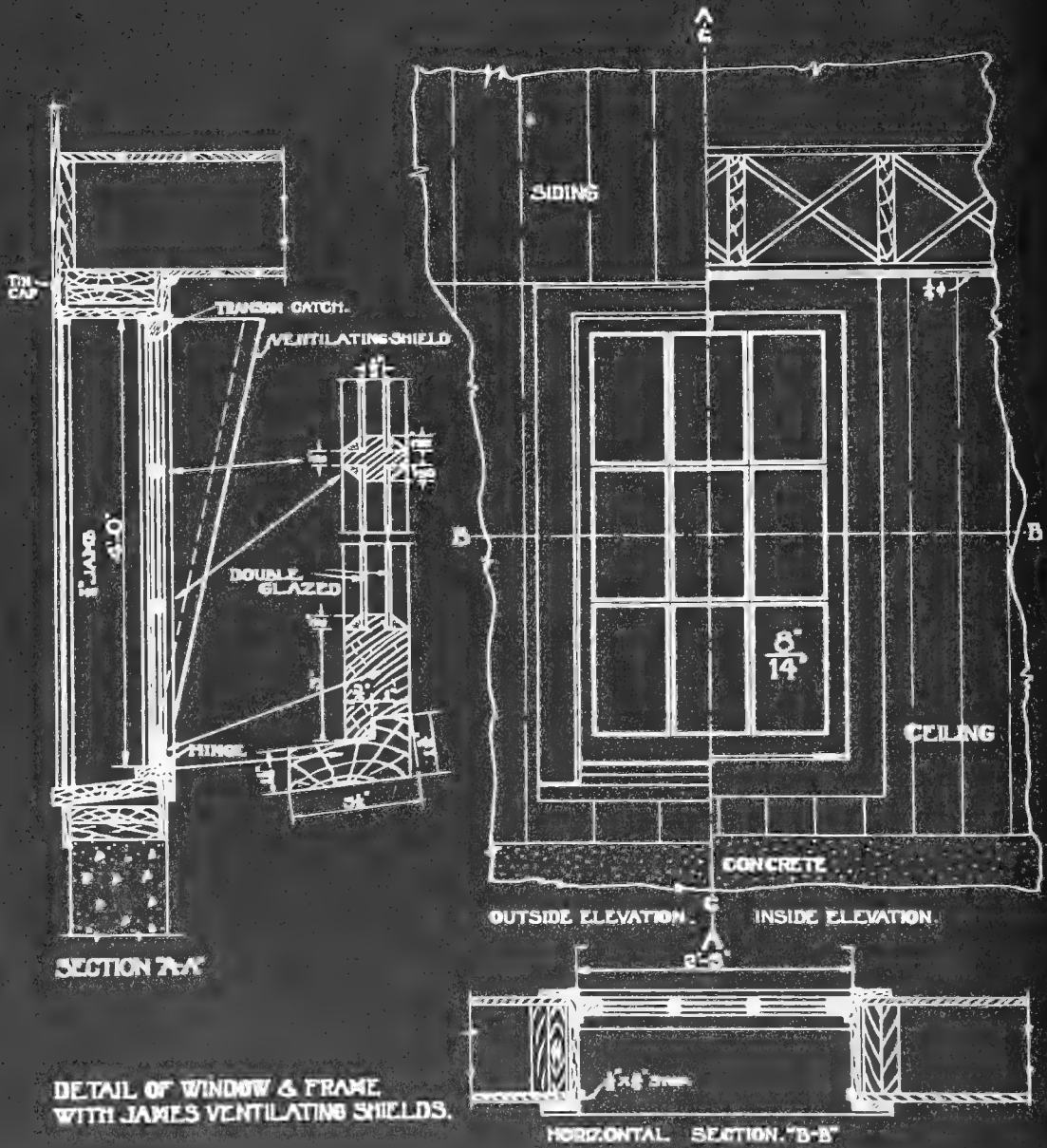
DETAIL OF CONNECTION



DETAIL OF PURLIN PLATE, ETC



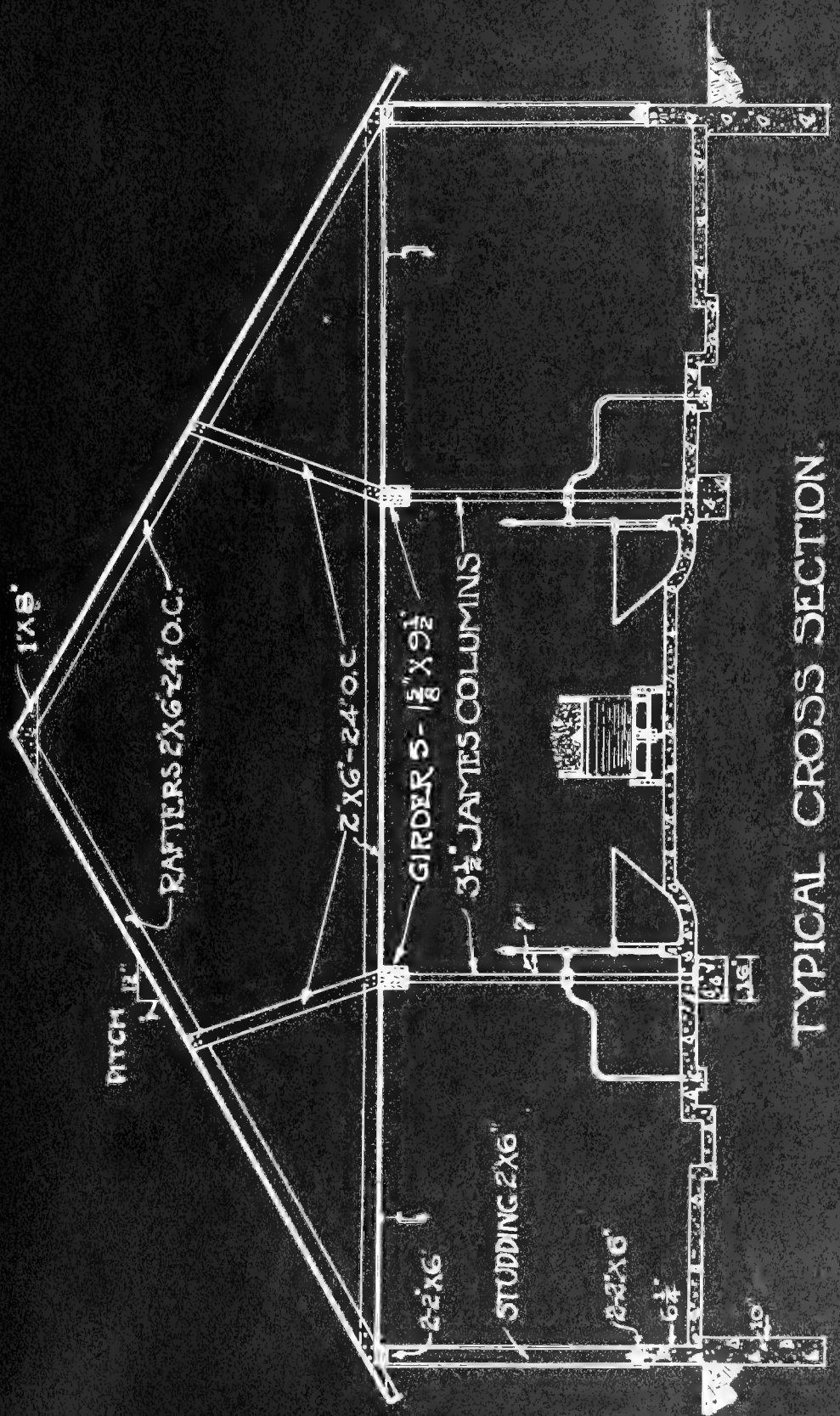
SLIDING DOOR FOR HAY CHUTE OPENING IN CEILING.



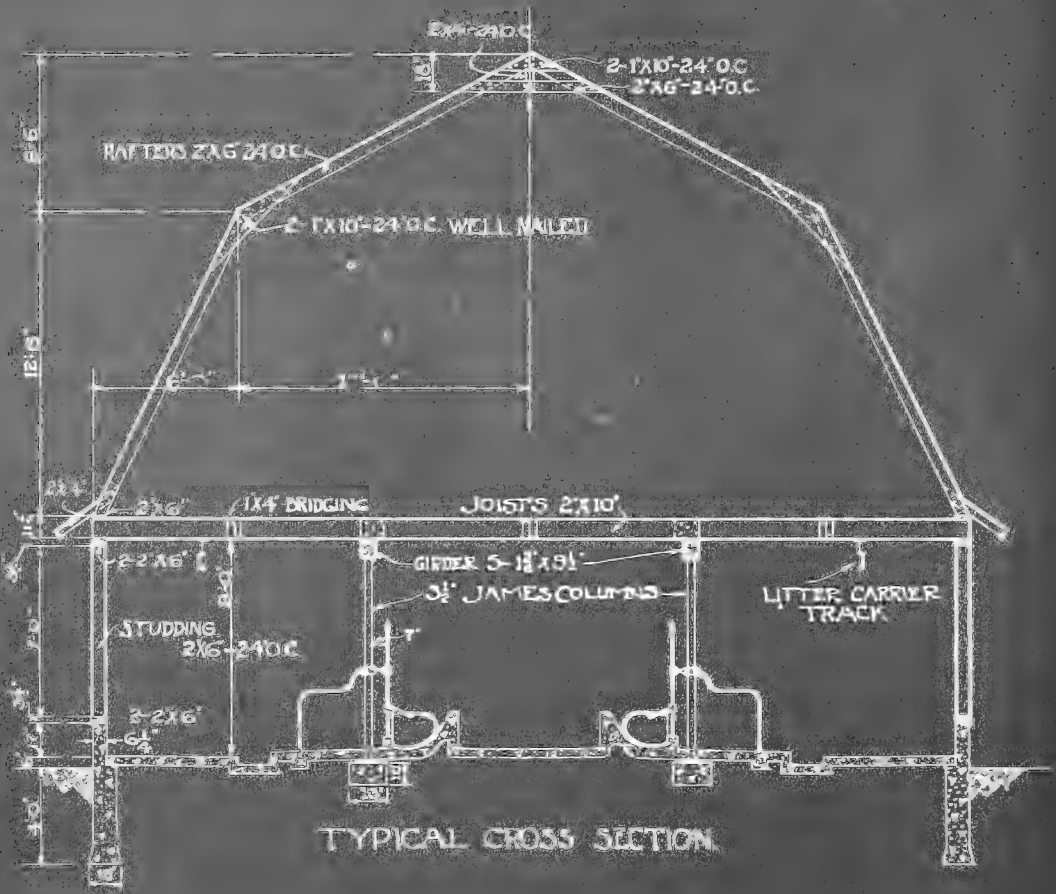
DETAIL OF WINDOW & FRAME WITH JAMES VENTILATING SHIELDS.

HORIZONTAL SECTION "B-B"



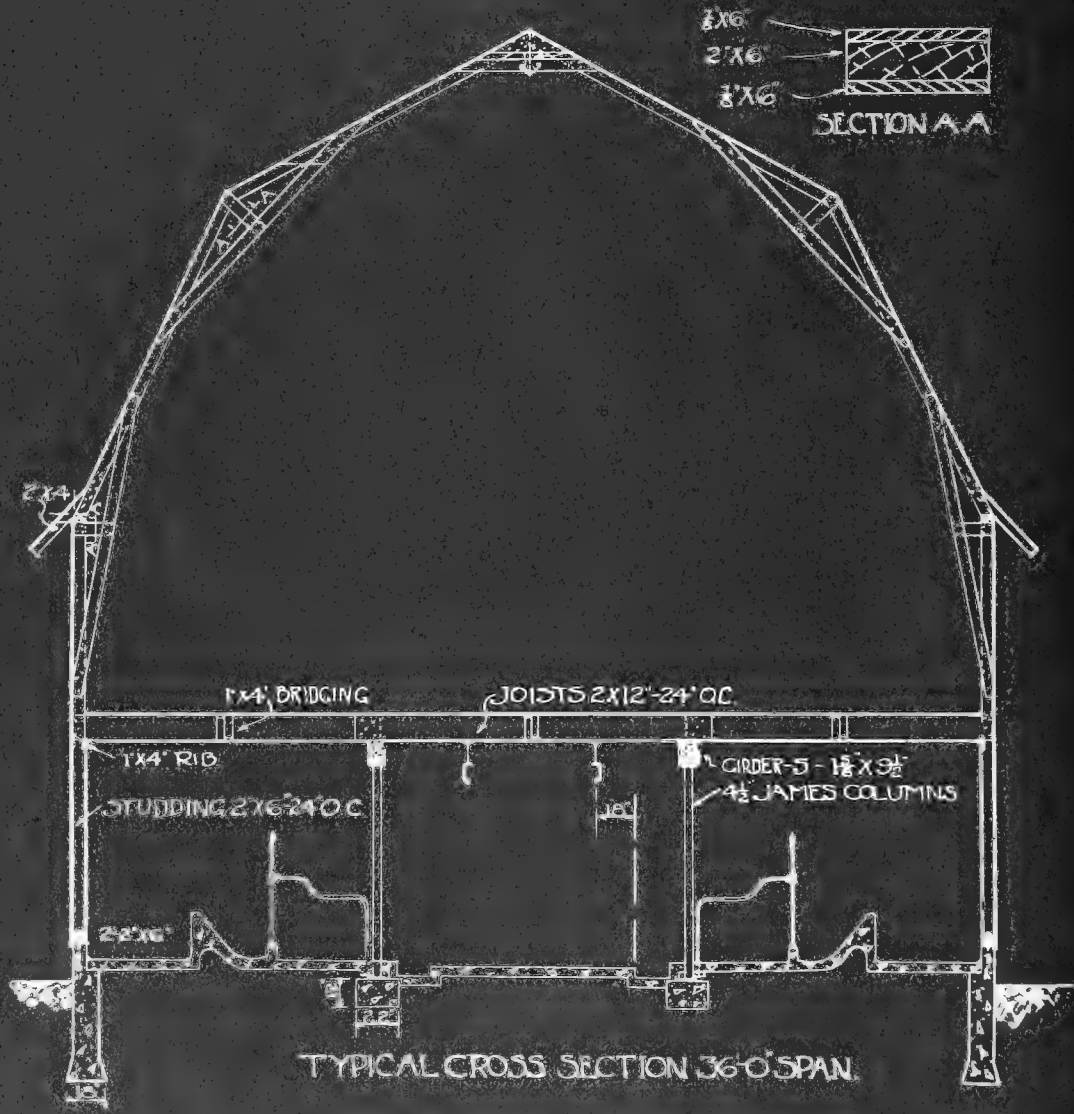


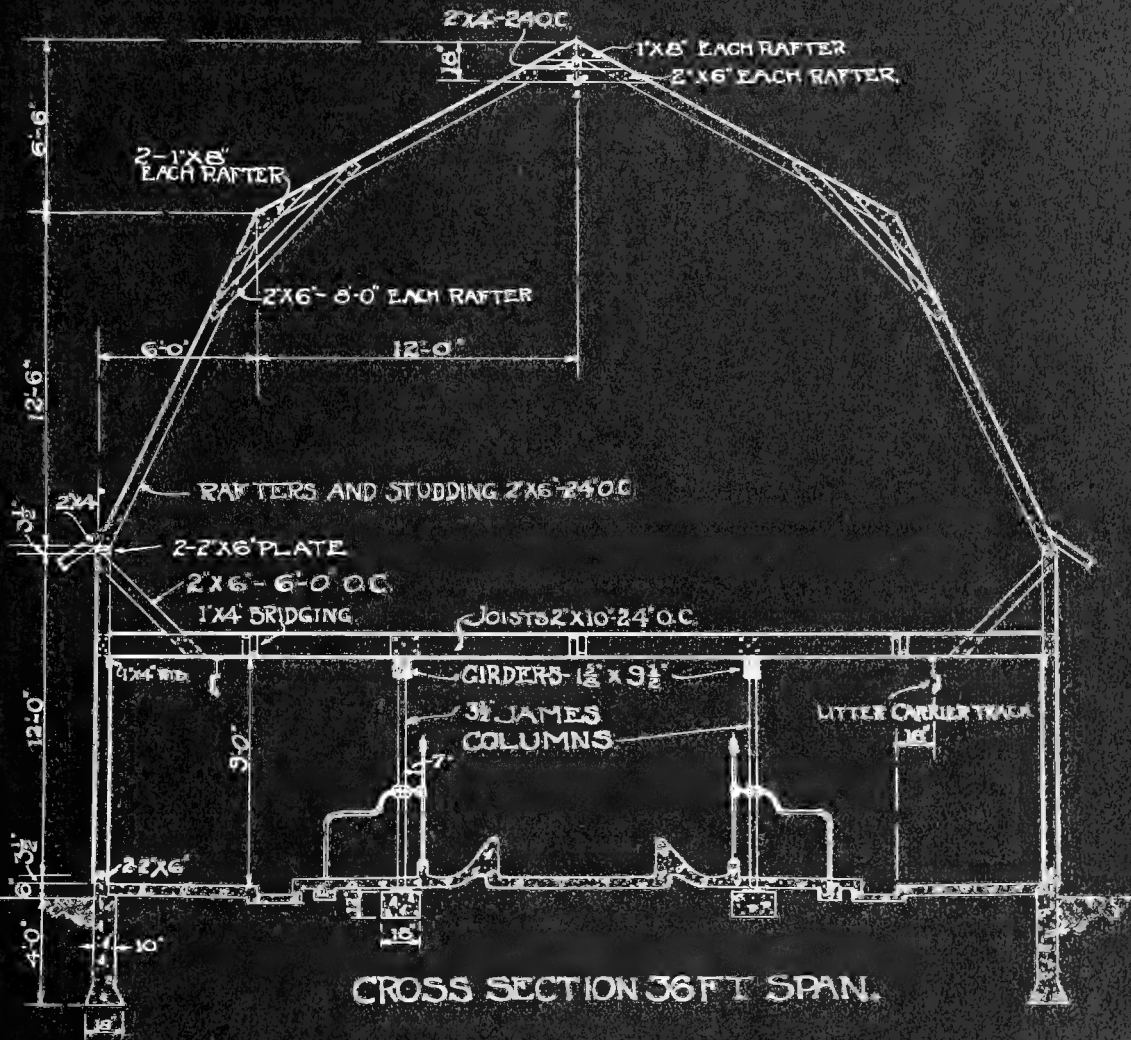
TYPICAL CROSS SECTION



One-Story Barn

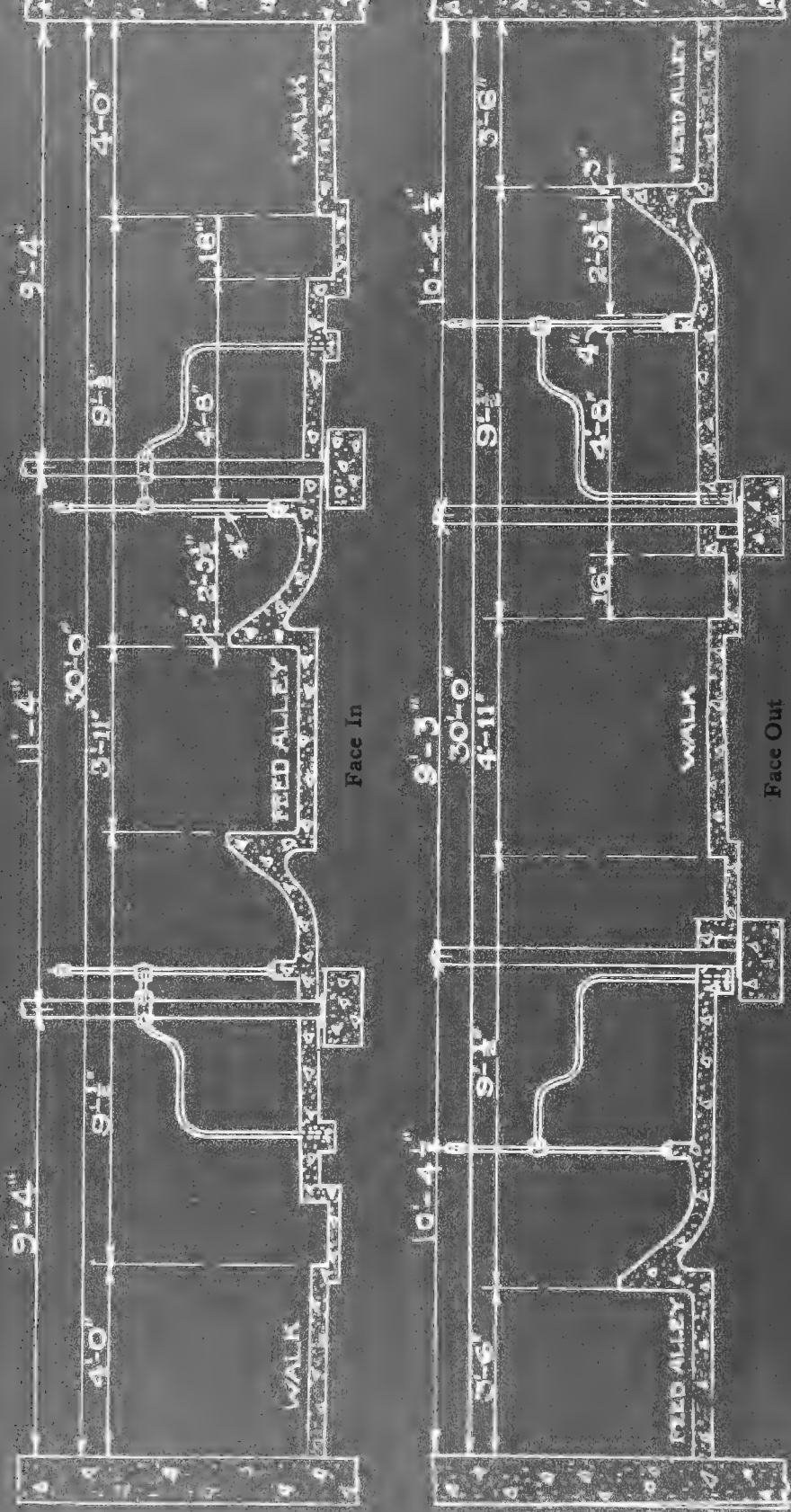




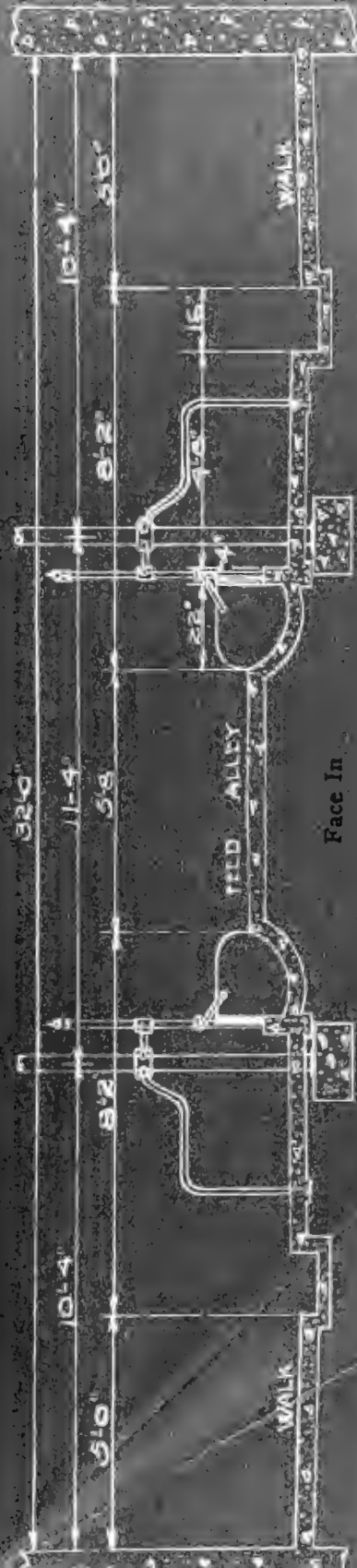




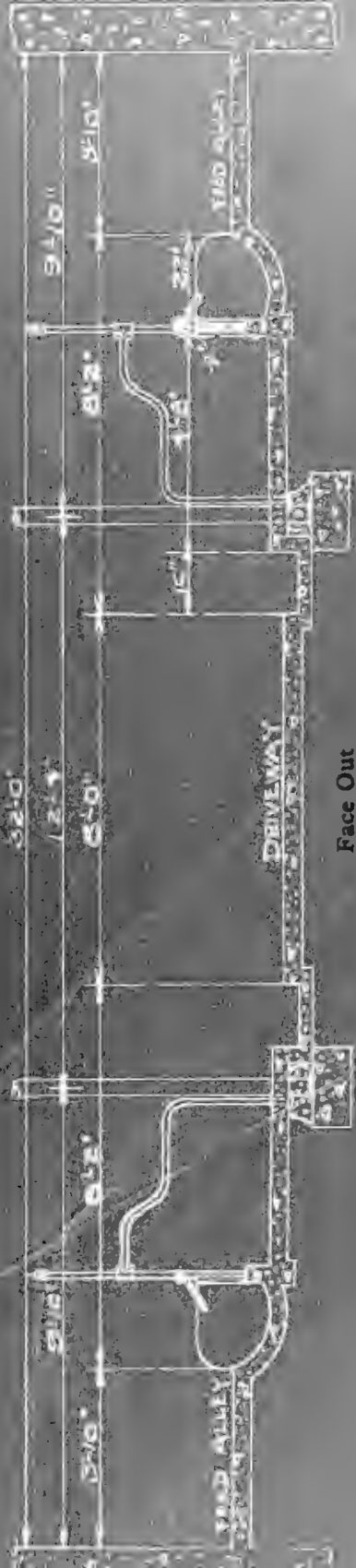
Cross Section — Dimensions, 30-ft. Barn



32-ft. Barn

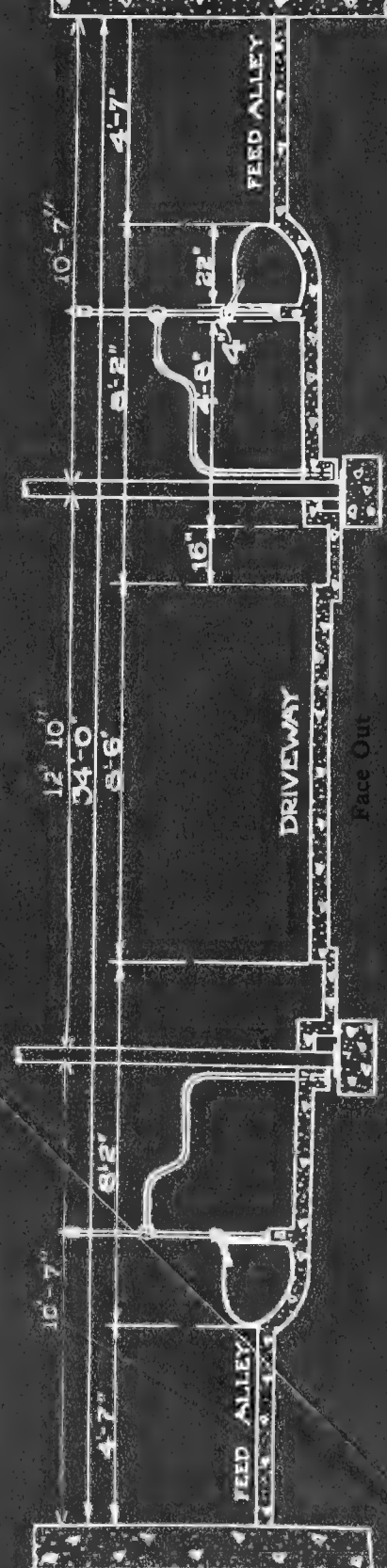
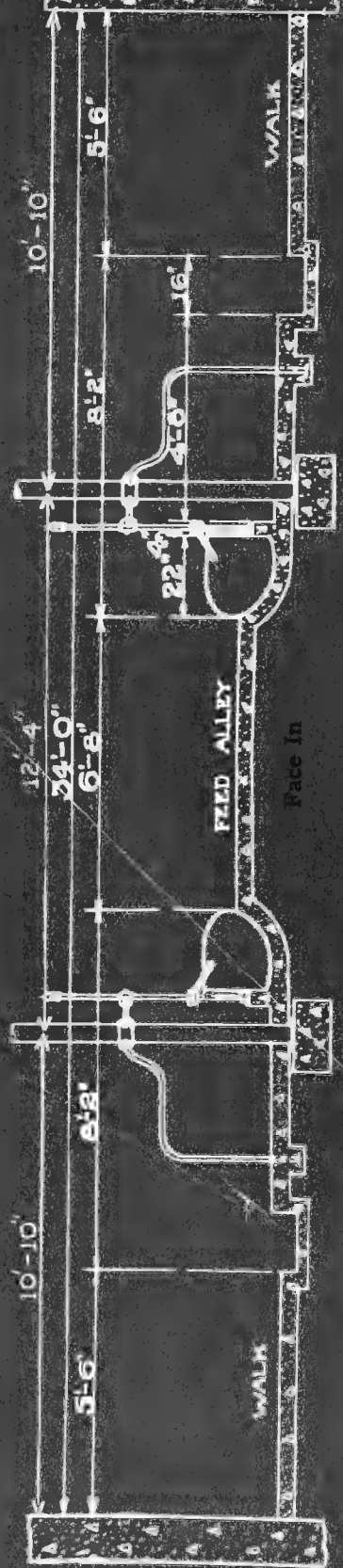


Face In



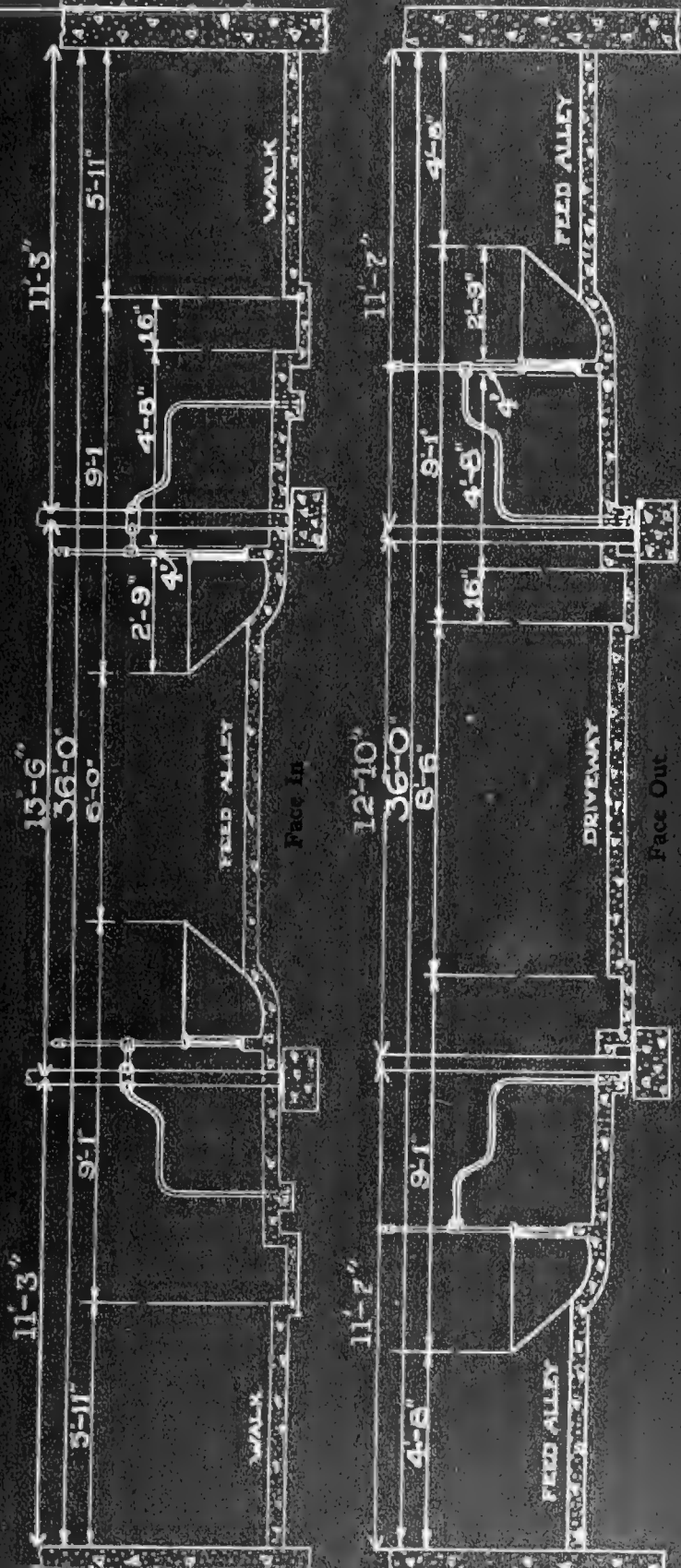
Face Out

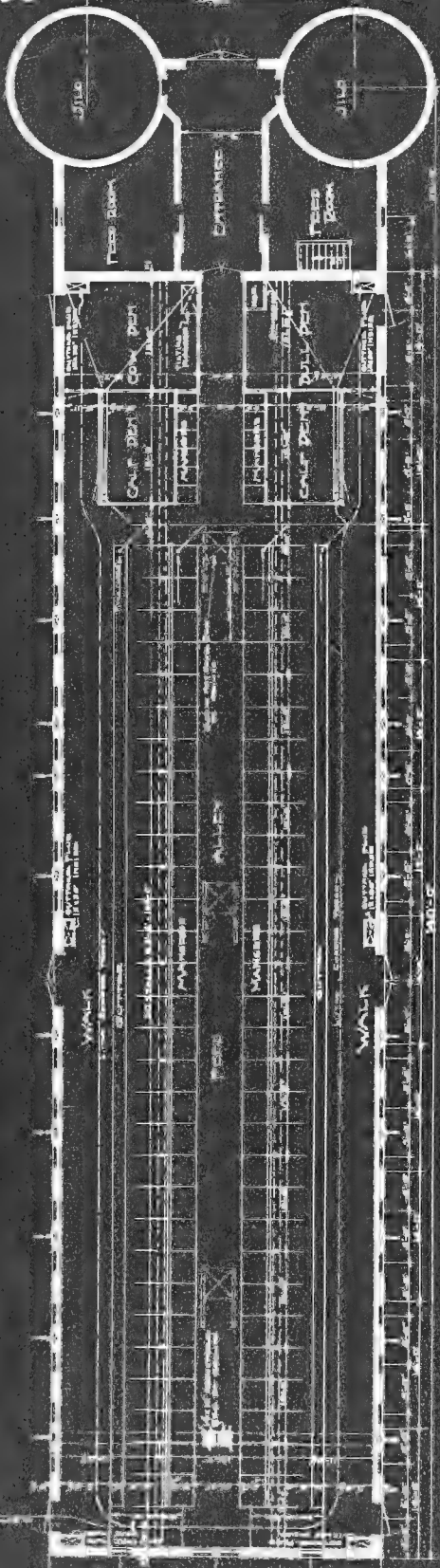
34-ft. Barn



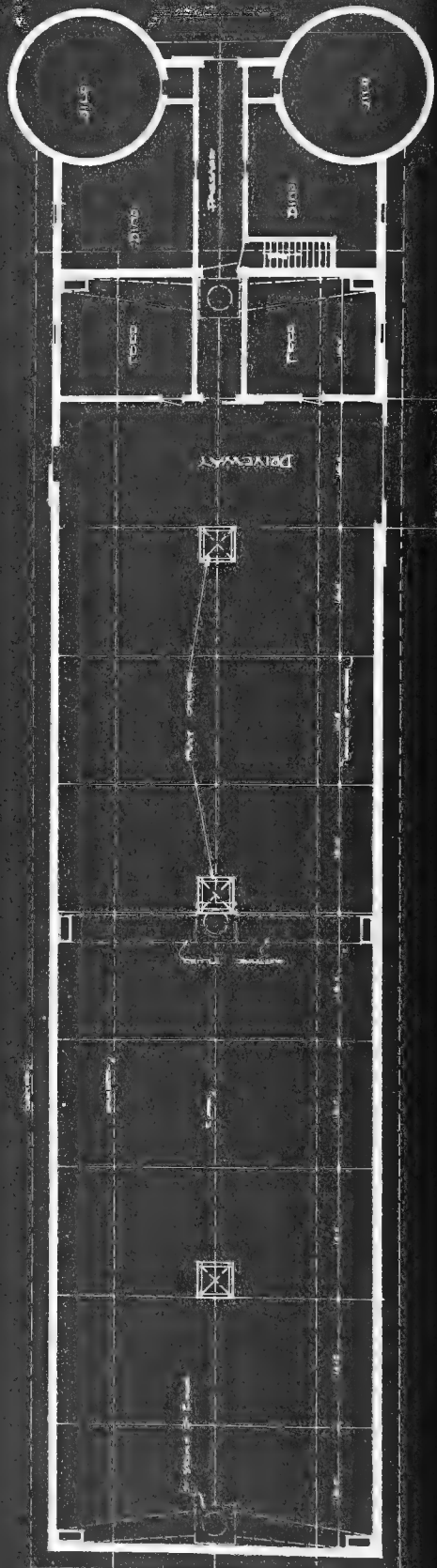


30-ft. Barn

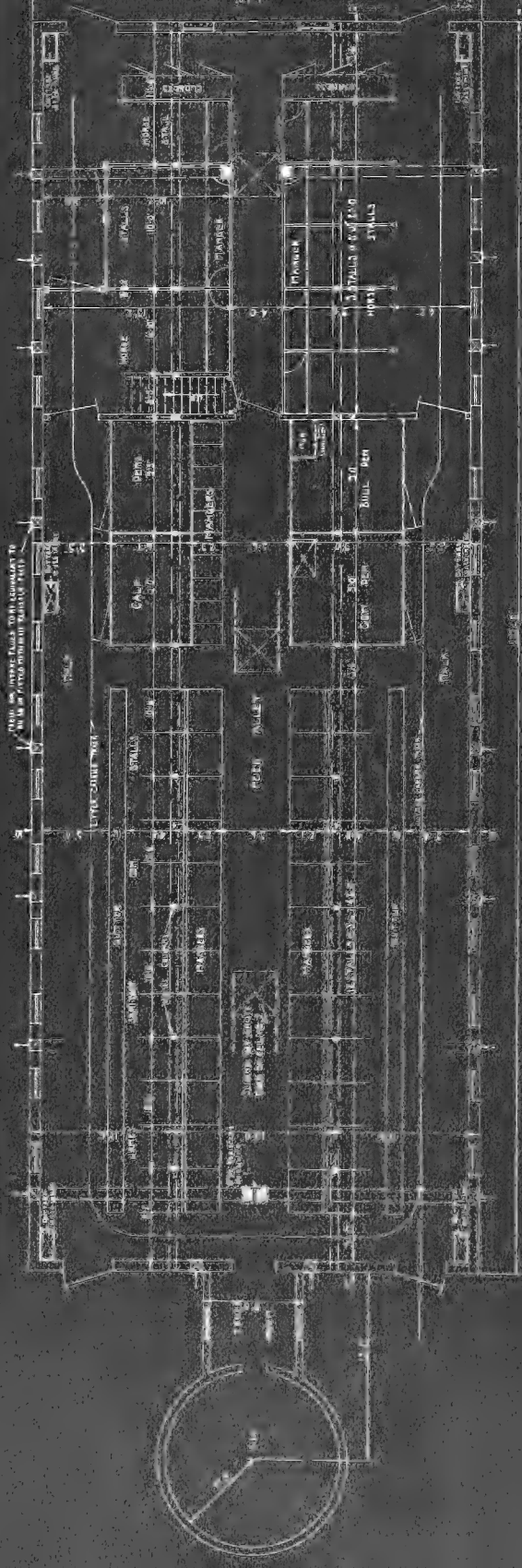




First and Second Floor Plans  
A Typical Barn







Floor Plan of a Typical Barn

# Ventilation

**R**IGHT here at the start, get this fact fixed in your mind—that VENTILATORS ON YOUR BARN DO NOT NECESSARILY MEAN THAT YOUR BARN IS VENTILATED.

—and remember this point too—that SOME ventilation is not *enough* ventilation.

Just look at the fallow, sickly people who live in city tenements. They are getting SOME air, but they are not getting ENOUGH.

Study a map showing where the tuberculosis cases are located—you will find these same tenements, hotbeds of the disease—all because of the lack of ENOUGH oxygen—PURE AIR—VENTILATION.

Just look at yourself with your rugged constitution, strength and vitality, in comparison with the city office man. You can see that *some* ventilation is *not* enough, either for men or animals.

As long as you hope to make a cent of profit in the dairying business you should remember this fact—that *milk and butter fat production depends absolutely and completely on cow health and vitality.*

So it is nothing less than a sacrifice of success and profit to supply your barn with anything less than a GREAT ENOUGH QUANTITY of FRESH, PURE, DUSTLESS AIR.

Every dairyman is constantly studying to supply the proper milk-making ration, yet health and proper digestion depend, first of all, on the adequate supply of fresh air, constantly.

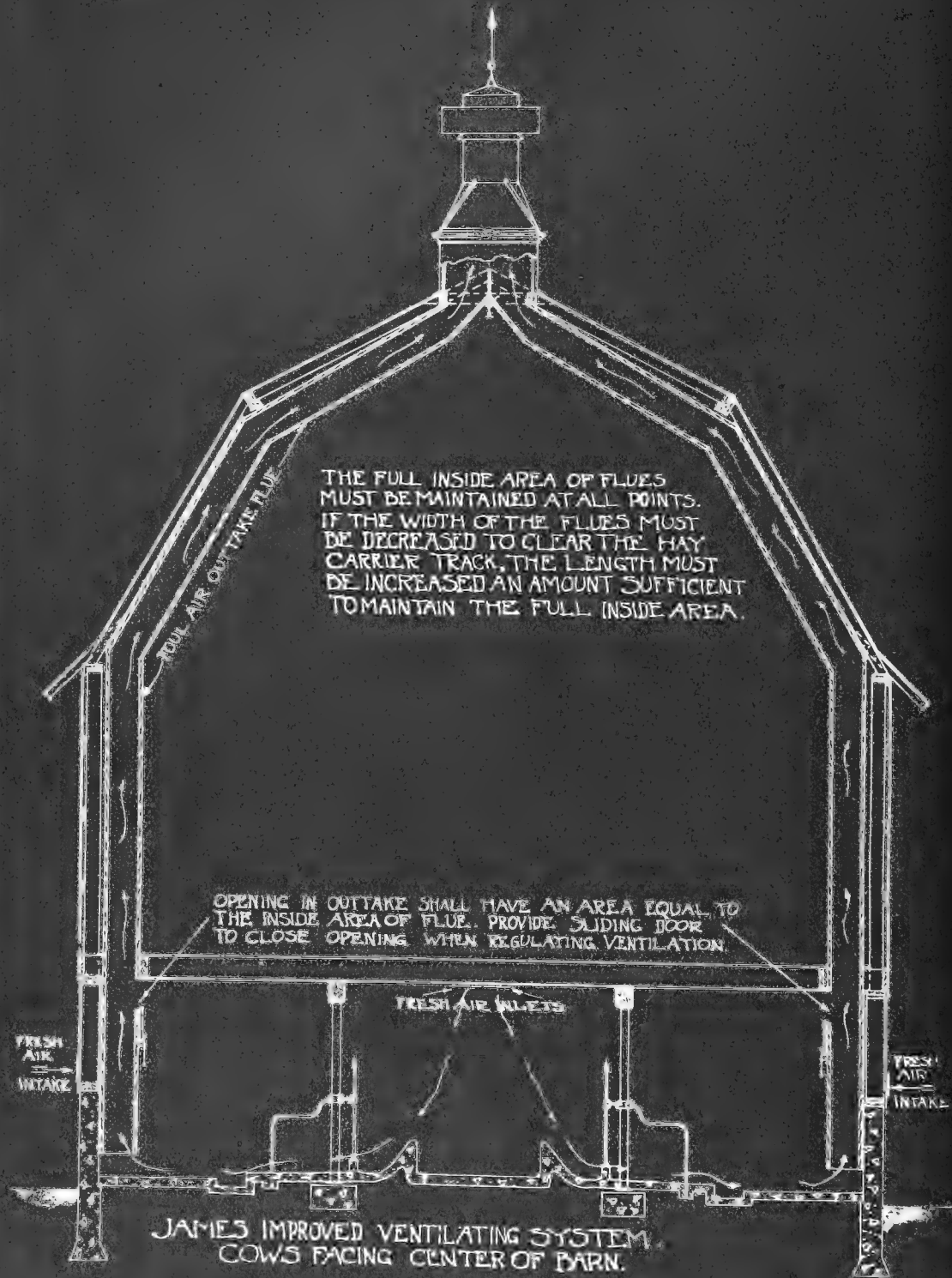
Every dairyman is on the look-out for cow-tuberculosis—he will go to extremes to prevent it—yet do you realize that the only treatment and cure for tuberculosis is fresh air? That is the way the medical authorities treat people in Sanitariums—make them live out doors! It is the same disease in cows, so you can be sure that abundance of fresh air, the only known cure for tuberculosis, is also the best preventive. The right barn ventilation is your best protection.

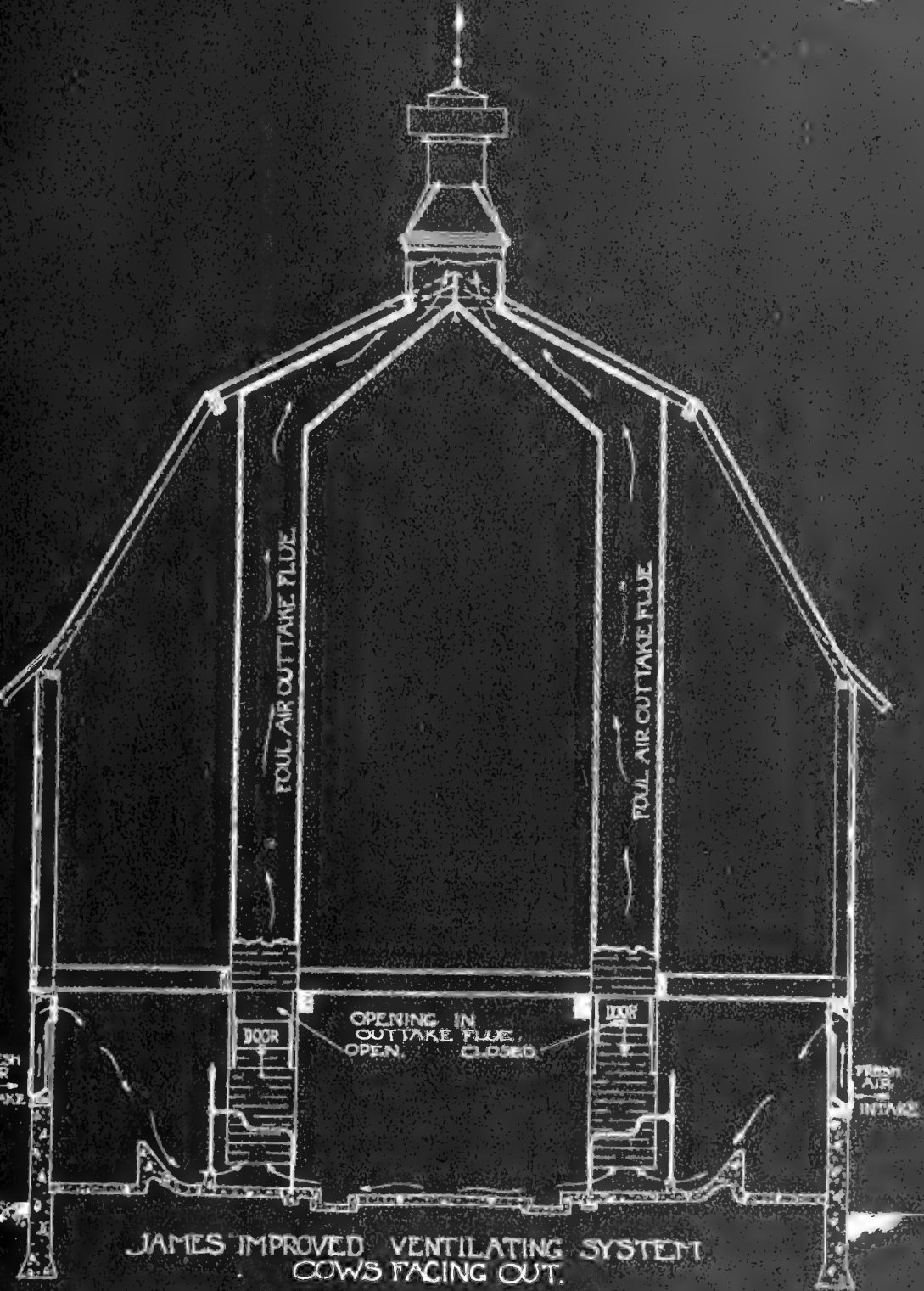
You have made an investment in your barn, and moisture is the one thing that is causing decay through the entire structure, and deterioration of hay and other forage. The moisture laden air breathed out from thirty cows will saturate the air of the barn with one and one-third barrels of water daily, to say nothing about moisture from other sources. *Correct ventilation takes out excessive moisture.*

That white coating which you see on harnesses, buggy tops and barn beams is ammonia carbonate, formed by the carbonic acid gas from air which has been breathed uniting with the ammonia vapors from manure. It rots everything. *Real barn ventilation takes ammonia carbonate out of the barn.*

Don't rest content in the belief that your barn is ventilated. Cupolas and ventilators on top of your barn do NOT mean ventilation inside your







FOUL AIR OUTTAKE FLUE

FOUL AIR OUTTAKE FLUE

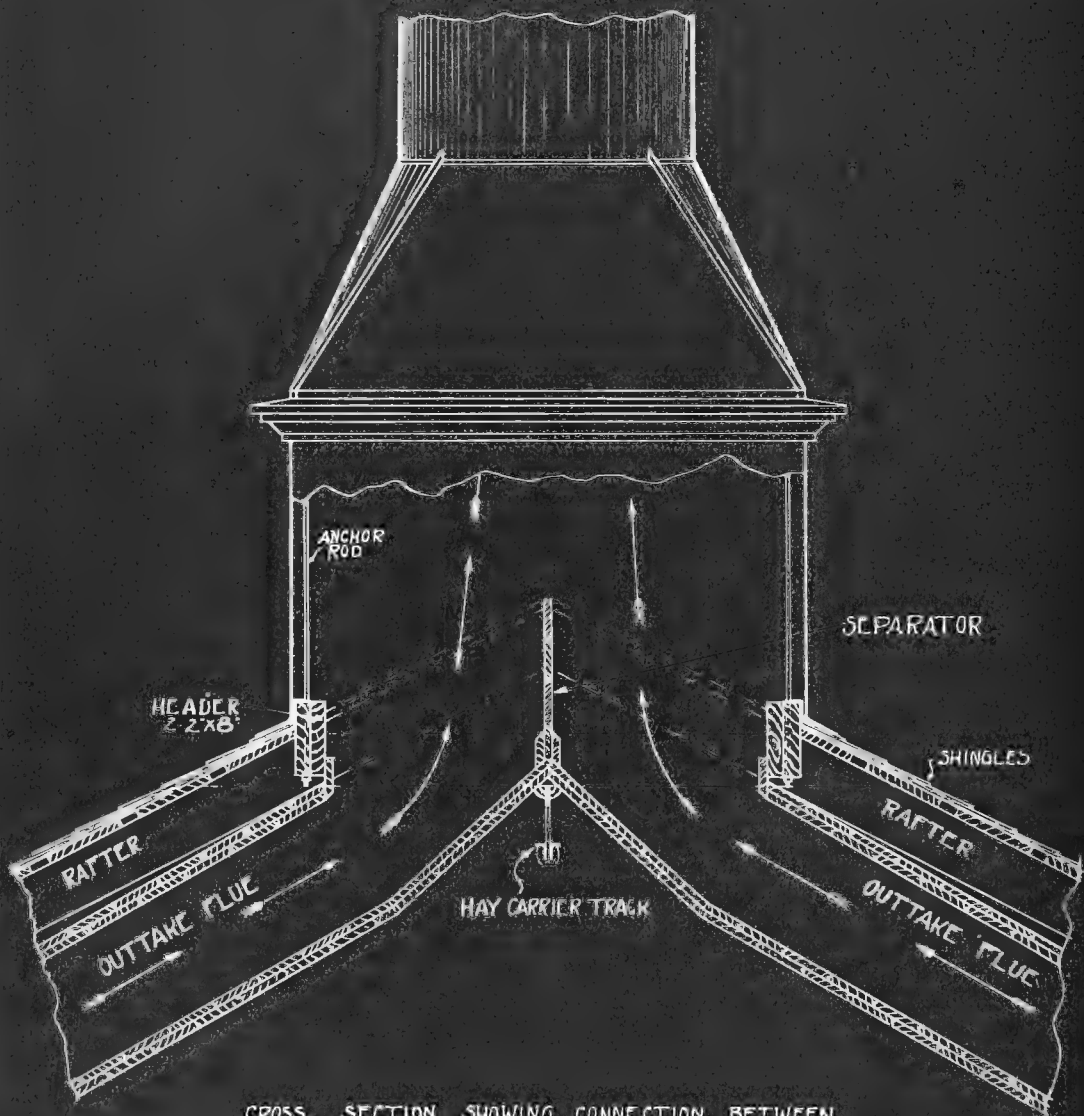
DOOR

OPENING IN CUTTAKE FLUE,  
OPEN.      CLOSED.

DOOR

FRESH AIR INTAKE

JAMES IMPROVED VENTILATING SYSTEM  
COWS FACING OUT.



CROSS SECTION SHOWING CONNECTION BETWEEN  
OUTTAKE FLUES AND BASE OF VENTILATOR.

NOTE- IF THE BASE IS NOT ENTIRELY COVERED BY THE  
OUTTAKE FLUES THE SPACE REMAINING MUST BE  
BOARDED UP TIGHT SO THAT NO AIR CAN ENTER  
FROM THE HAY LOFT.



barn. That's the WRONG IDEA that is costing dairymen of America thousands of dollars in decreased milk production, losses from disease, in depreciation of barns, equipment, hay, feed and in spontaneous combustion fires.

A cold barn does not mean a well-ventilated barn either. Foul, moisture-saturated air gets just as cold as pure air.

THE VENTILATORS THEMSELVES ARE ONLY PART OF THE VENTILATING SYSTEMS.

Your barn is not ventilated unless it is supplied with the right amount of pure air per animal—unless the entire volume of air in the entire barn is renewed constantly.

—and it is not rightly ventilated unless the warmth is kept in the barn, while the foul air and excessive moisture, floating dust and germs are expelled—unless every part of the barn from basement to haymow is kept free from foul air, gases and damaging moisture.

Your barn is not rightly ventilated unless this complete ventilation is accomplished without strong drafts and air currents, which not only fail to give complete ventilation, but keep harmful dust afloat in the barn. All the air must be completely changed, not merely stirred up.

No Sir—just cupolas, or ventilators by themselves, will never give real ventilation. *There's got to be a system behind the ventilator.*

The health laws of every state demand a certain number of cubic feet of fresh air per person in schools, churches, theaters, etc.—and it takes expert engineers to provide it. It is no easy, simple task—it is no easier with barns. It takes the same expert engineering.

Yet while the ventilators are only part of a system—the EFFICIENCY of the WHOLE system depends on them.

Cupolas and ventilators without a properly designed system are of no ventilating worth. You can't just buy a ventilator and supply your need. That's a big point to remember.

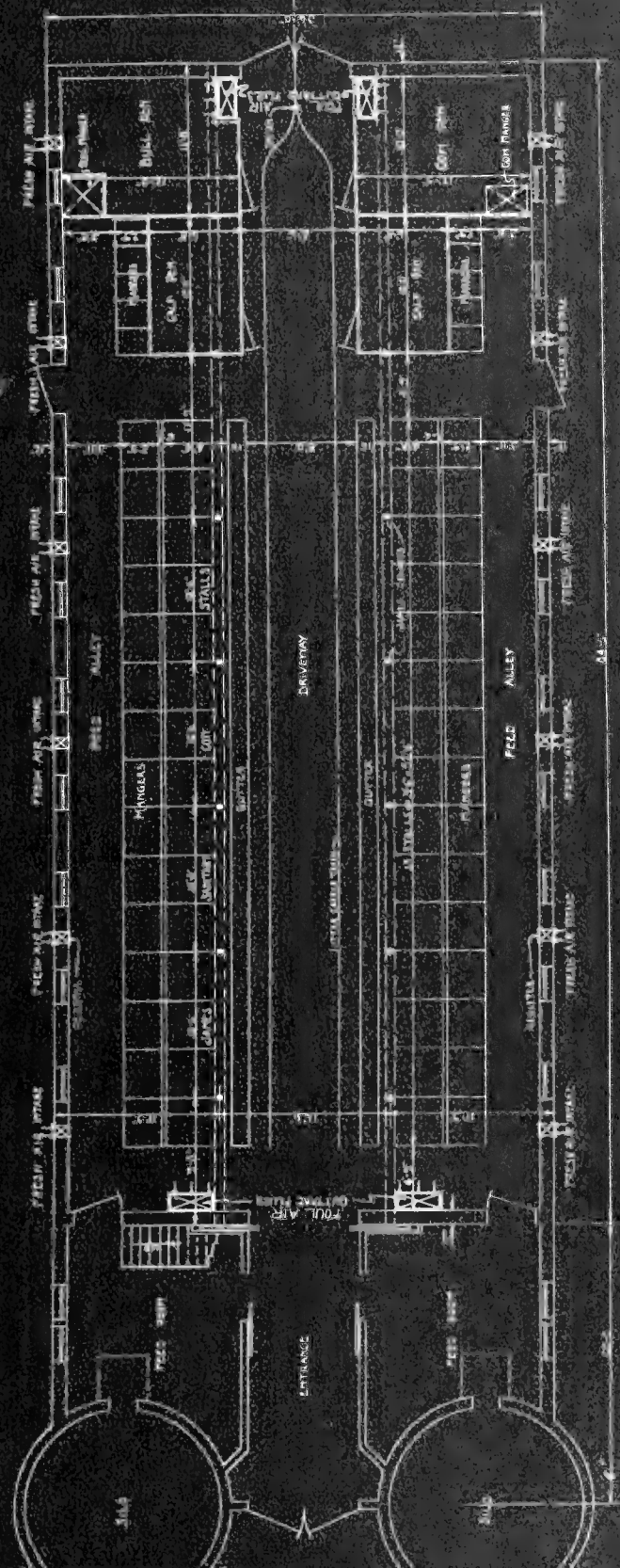
Yet, with the properly designed system, you still must take great pains in selecting the right ventilator. If your ventilator doesn't release the proper volume of air, your system doesn't work. It's the old case of no chain being stronger than its weakest link.

Correct barn ventilation is only possible when you have both a correctly designed ventilating system, and a correctly designed ventilator. The lack of either one will prevent proper barn ventilation.

Now let's study this matter of ventilation carefully and get a thorough understanding of it.

Ventilation is the process of creating and regulating diffused air currents, removing foul air and introducing sufficient pure air into a building, so that a certain standard of purity healthful to man and beast is at all times maintained.



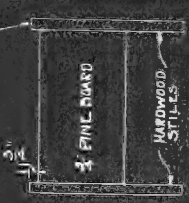


ARRANGEMENT OF INTAKES AND OUTTAKES  
COWS FACE OUT.

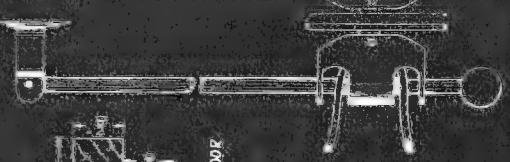
THE SHIM OR CONTINGENT IS PLACED IN AN AREA EQUIVALENT TO THE INSIDE AREA OF FLUE.



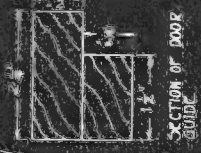
SECTION OF DOOR AND HARDWOOD STILE



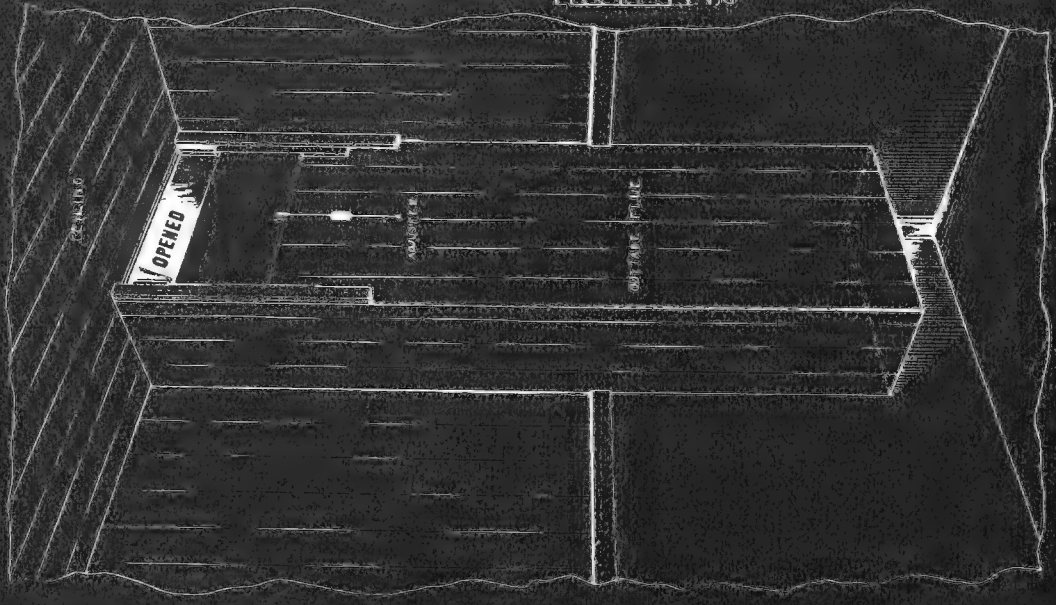
SLIDING DOOR



DOOR ADJUSTER



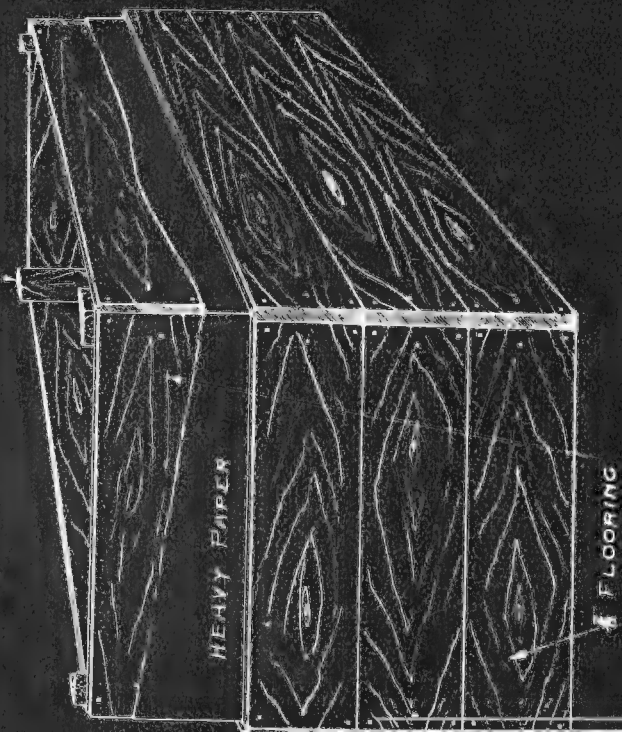
SECTION OF DOOR GUIDE



OUTTAKE FLUE WITH OPENING & DOOR AT CEILING



SECTION OF DOOR AND HARDWOOD STILE



DETAIL SHOWING CONSTRUCTION OF OUTTAKE FLUE

A man can live forty days without food and seven days without water.

He can live but a few minutes without AIR.

A cow can live longer than a few minutes without PURE air; but the more impurities there are in the air she breathes, the greater will be the tax upon her health and upon her ability to produce milk—the greater will be the tax upon her vitality and upon life itself. In poorly ventilated barns, the air is breathed over and over again, and becomes poisonous; cows in such a stable become less able to resist disease, and cannot recover from diseases as easily.

Air, water and food are the three great essentials of life, and of the three AIR may fairly be considered the most important, because it is the FIRST great life-sustaining element for all animals.

How necessary pure air is to life and to the maintaining of vitality and energy is well illustrated by many interesting items cited by writers on the subject.

Near Naples, Italy, is the famous Dog Grotto, which is filled to a certain height with carbon dioxide, the same element that is thrown off by the lungs. So powerful is this carbon dioxide, or rather so powerful is the lack of oxygen because of its presence, that a dog brought into the grotto is rendered insensible within a few minutes. This experiment is often performed, on payment of a small fee, for the amusement of travelers.

The effects of breathed air have been frequently tested in schools where for a short time the ventilation had been cut off. The pupils at first complained of being cold, and it was found necessary to raise the temperature from 70° to 80° Fahr. before the occupants of the room were warm. This no doubt was due to the reduction in vitality owing to the impurity of the air and a lack of oxygen in the lungs. After the ventilation had been cut off for twenty or thirty minutes, the pupils began to complain of headache.

Everyone knows how quickly impure air in a room—a church or lecture hall, for instance—will cause a person to become sluggish and drowsy, and how it destroys energy.

In our histories at school, we used to read of the Black Hole of Calcutta, where, in 1756, 146 prisoners were confined in a cell 14 ft. 10 in. by 18 ft., having but two small windows—all but 23 dying during the night, for lack of oxygen.

### How Much Air Does a Cow Need?

One writer vividly illustrates the vital importance of PURE air to the animal by pointing out what a task it would be to carry fresh air to a cow in a 3-gallon pail, as one might carry water. To supply a cow in this way,





would require  $5\frac{1}{3}$  full pails of fresh air each minute, or a total of 7,680 pails each twenty-four hours.

This amount of fresh air would contain 3 pails of carbon dioxide; after the cow breathed the air it would contain  $307\frac{1}{3}$  pails of carbon dioxide; and almost a pail of water would be given off by the cow through her lungs and pores.

A cow consumes TWICE the WEIGHT of pure air that she does of FOOD AND WATER COMBINED.

Can you realize what an amount that is?

Pile up a day's ration of hay and silage and grain; beside it put the pails of water a cow will usually drink in a day.

The WEIGHT of that food and water equals just about ONE-HALF the WEIGHT of the air the cow requires during the twenty-four hours. And that is figured on the basis of pure, fresh air at that.

To phrase it in another way:

The average cow requires for six months' rations about  $2\frac{1}{2}$  tons rough feed,  $3\frac{1}{2}$  tons silage, 1 ton concentrates and  $13\frac{1}{2}$  tons water, a total of  $20\frac{1}{2}$  tons, or 41,000 lbs.

For the same period, the cow requires 82,000 lbs. of air, or 41 tons.

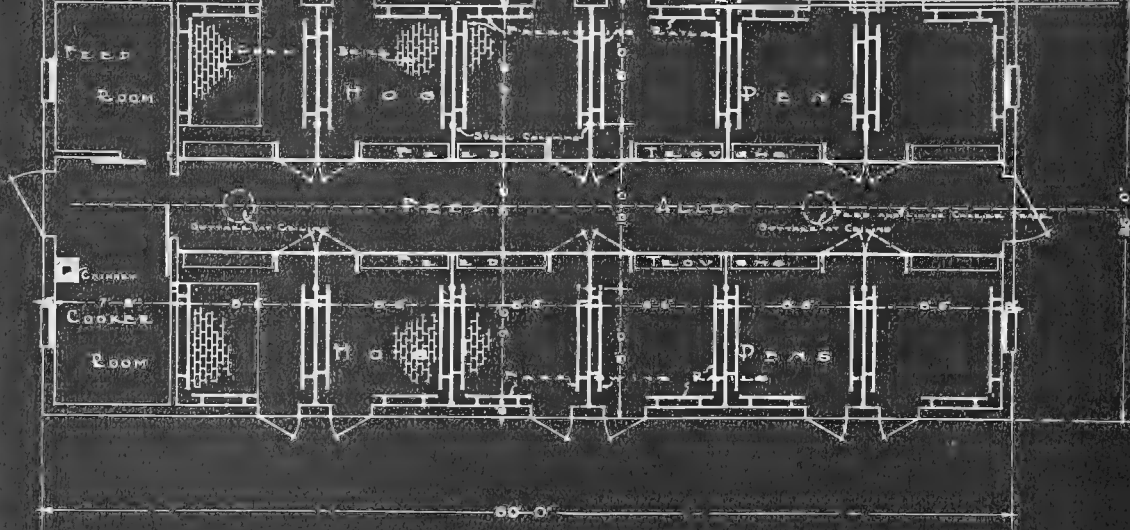
The  $20\frac{1}{2}$  tons of feed each, above mentioned, for 20 cows would fill 40,000 cu. ft., or the loft of a barn 36 ft. x 60 ft. with 14-ft. side posts and gambrel roof.

The 41 tons of air each for 20 cows would fill the loft of such a barn 36 ft. wide with 14-ft. side posts and gambrel roof, 10 miles long.

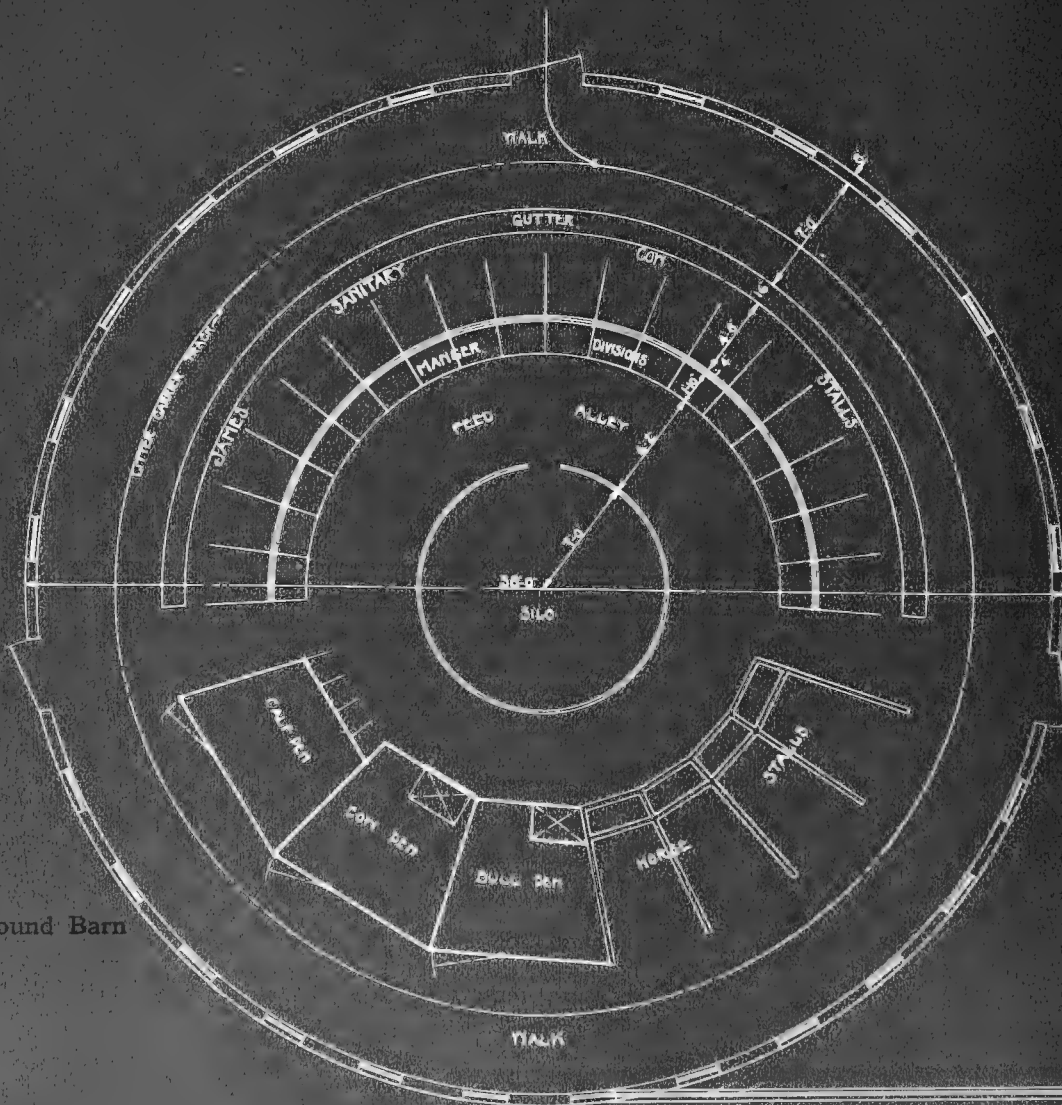
The scientists tell us that air is not a simple substance, but consists of a mechanical mixture of the gases oxygen and nitrogen with about 1 per cent by volume of argon. Atmospheric air of ordinary purity almost always contains a little carbon dioxide together with more or less vapor of water, and a very active form of oxygen known as ozone. The average composition of air is given as follows:

Oxygen .....	20.588
Nitrogen .....	76.765
Carbon Dioxide.....	0.039
Water .....	1.686
Argon and other constituents.....	0.922
	<hr/>
	100.00

The air as thrown off by the lungs at 90 to 98 degrees Fahr. is nearly saturated with water, and contains from 3 to 5 per cent carbon dioxide; hence, it is from 1 to 3 per cent lighter than the air inhaled.



Hog Barn Floor Plan



Round Barn



The following table shows the approximate effect of respiration on the composition of air:

	Entering Air	Respired Gases
Oxygen, per cent of volume.....	20.59	15.74
Nitrogen and other constituents.....	77.68	75.29
Carbon Dioxide .....	0.04	4.00
Water .....	1.69	4.97
	<hr/> 100.00	<hr/> 100.00

It is the oxygen that is the energy and life-producing element; without it there can be no animal life. Oxygen is not to be considered as having any properties as a food, but is rather the necessary element which makes it possible to assimilate and utilize the food.

While the air is in the lungs, the oxygen which is imparted to the tissues acts upon the carbon of the blood, forming chemical compounds which are thrown off in respiration; this process resulting in the production of heat and energy so necessary to life.

A similar process occurs with the burning of coal or wood in the stove.

The oxygen of the air unites with elements in the fuel to produce that energy we call heat, and the same waste products are formed—carbon dioxide, ammonia gas and water vapor.

This waste—the smoke and the ashes—must be removed from the stove, and oxygen supplied—or the fire will cease to burn.

In the same way, the respired or breathed air *must* be removed from the stable, and fresh air supplied, so that the cow may have *oxygen* on which to live and supply the energy necessary to produce milk.

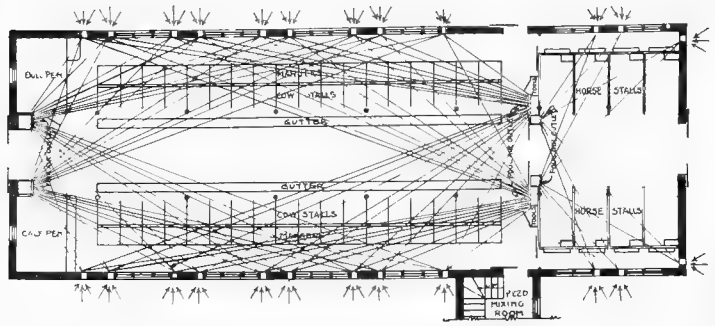
If the stable were air-tight, and no fresh air introduced, the cow would die, just as the fire choked with ashes will soon go out, though it may be plentifully supplied with good coal or wood.

Fortunately no stable is air-tight; but in the colder states of the north, most stables are built as tight as possible, to insure warmth for the cows.

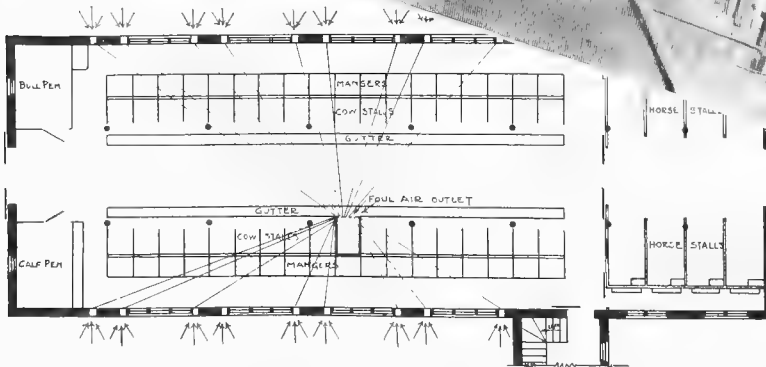
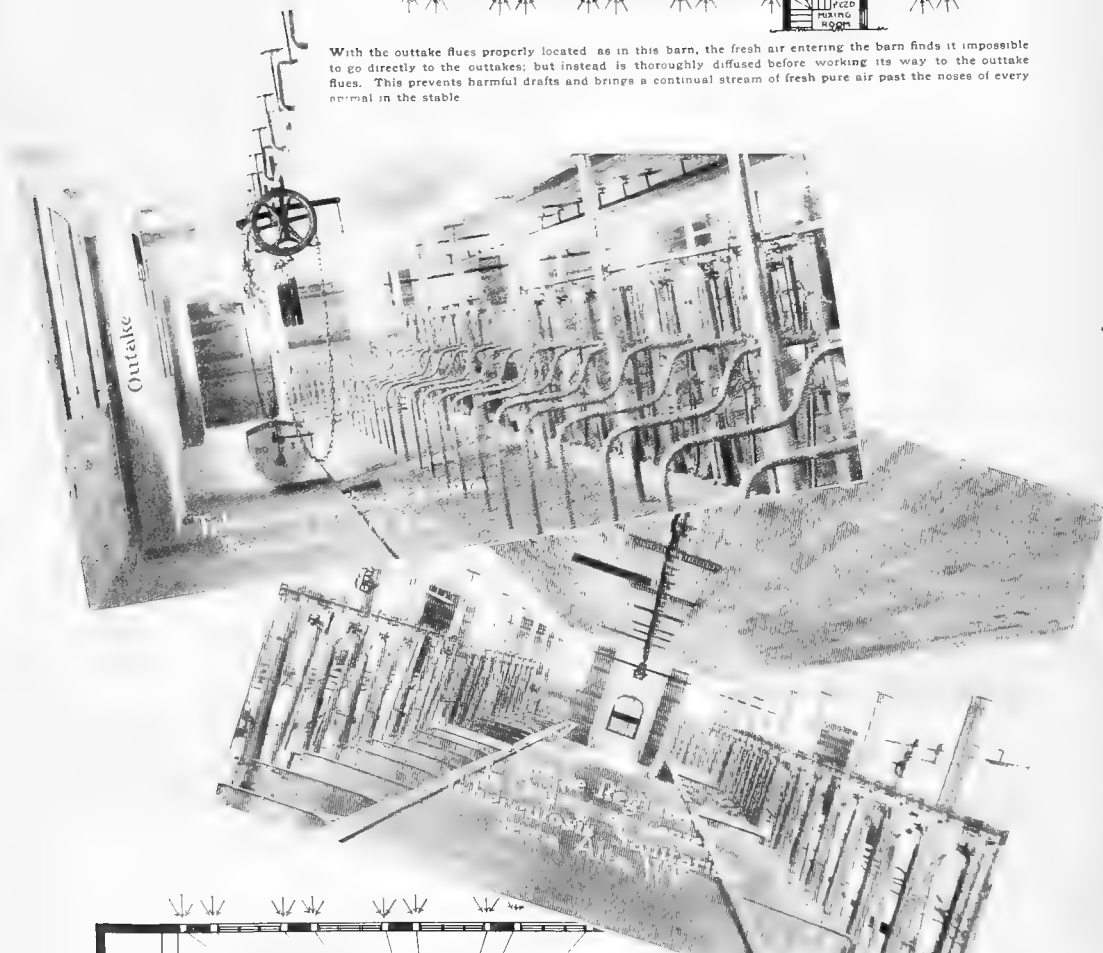
Conditions in this respect are rapidly improving; but even today very few stables, comparatively, provide sufficient ventilation—enough *oxygen*—to enable the cows to make the most milk possible from the feed and water they consume.

In all such cases, providing plenty of fresh, pure air will result in greater milk yields.

Actual experiments have proven that cows stabled in ordinary barns without adequate ventilation, will give more milk when the proper ventilation is provided; and when the operation of the ventilating system is stopped, their milk yields will immediately decrease to the former amount.



With the outtake flues properly located as in this barn, the fresh air entering the barn finds it impossible to go directly to the outtakes; but instead is thoroughly diffused before working its way to the outtake flues. This prevents harmful drafts and brings a continual stream of fresh pure air past the noses of every animal in the stable.



This illustrates an incorrect location of outtake flue. The tendency of the air is to take the most direct route to the outtake flue; with the outtake so located, there would be many places in the barn where the foul air would remain stagnant, and a certain proportion of the animals in the barn would be forced to breathe foul air over and over.

Not only is oxygen more necessary to life than food and water—not only does the lack of sufficient oxygen reduce the milk yield—but it affects the health and vitality of the animal, making her less able to resist disease.

Now, out-of-doors the cow gets all the pure air, all the *oxygen she needs*. But it is far different in the winter time, when she is confined to the barn.

In many barns, the cows must breathe the same air over and over, excepting for the small proportion which may leak in from outside through cracks and through the occasional opening of a door.

To get the most milk possible from his cows and to make more profits, the owner must in some way bring plenty of pure air to the cow's nostrils.

Since air is the most important element in maintaining life and energy—since a cow consumes twice the weight of air that she does of food and water combined—and since air costs absolutely nothing—the owner of cows can afford to study this matter carefully, and make certain that his animals are being fed *all the oxygen they need*.

The water vapor present in breathed air must also be removed from the barn.

The moisture thrown off by the average cow in twenty-four hours amounts to  $11\frac{1}{2}$  pounds, or  $1\frac{2}{5}$  gallons of water.

Thirty cows will load the air in the stable with  $1\frac{1}{3}$  barrels of water daily.

If that amount of excess moisture is permitted to stay in the barn, the results are harmful not only to the cows but to the barn itself, rotting the sills and timbers and shortening the life of the building.

This excess moisture in the stable air causes that disagreeable “steaming” so noticeable in many barns on cold days.

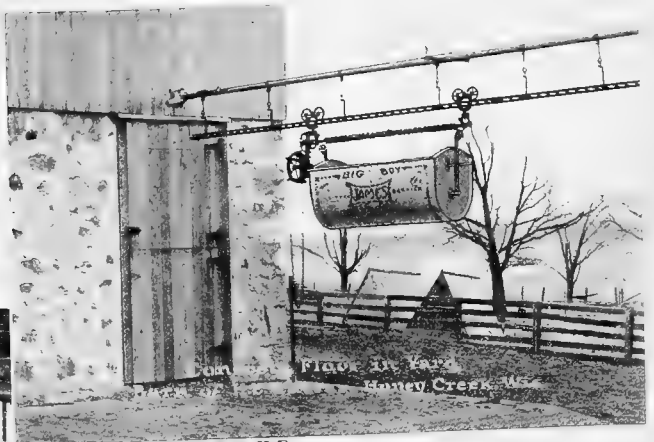
This “steaming” is a sure sign that the moisture is not being carried off by the ventilating system, that the air in the stable is not being changed with sufficient frequency to keep it fresh and pure.

If the ventilating system used in the barn is a successful one, all this moisture will be promptly removed; but if there is too slow a change of air this moisture will remain in the barn, condensing on walls and ceiling, making the harness damp and frosty and the hay heavy and wet.

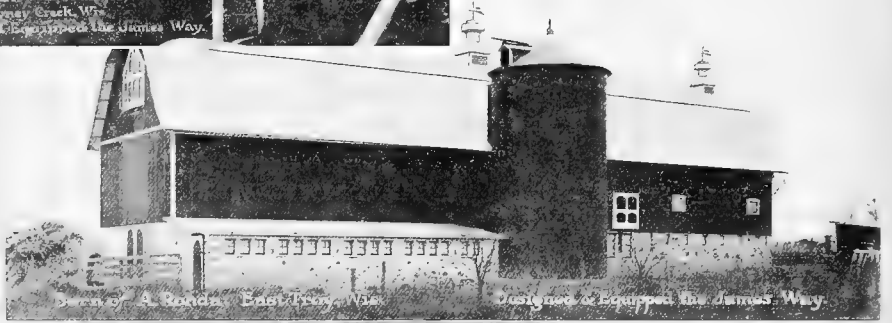
## How to Ventilate the Barn

With the right system of ventilation, the stable may be kept comfortable at all times, yet the air will be pure and free from odors.

Some think that the opening of the haychutes provides proper ventilation. While this may effect a sufficient change of air in the stable, it does it at the expense of heat, making the barn cold; removing all of the warmest air which is at the ceiling.



John H. E. Calkins  
Honey Creek, Mo.  
Designed and Equipped by James Way.



Design of A. F. Jones, Honey Creek, Mo. Equipped by James Way.



Design of H. E. Calkins  
Honey Creek, Mo.  
Designed and Equipped by James Way.



Design of H. E. Calkins

Another objection is that the warmer air of the stable coming in contact with the cold air in the haymow condenses the moisture. The moisture and some of the foul elements of the air from the stable are deposited on the hay, and is fed again to the cows.

If any cow in the herd has tuberculosis this may be a very serious matter. The germs of tuberculosis and other diseases have no power of locomotion themselves, but are readily carried on particles of dust. With the right method of ventilation these particles of dust, carrying the disease germs, would be conveyed through the outtake flues out of the barn and into the open air and sunlight, where they quickly perish.

If the air with its load of germ-carrying dust is taken into the haymow much of the dust with the germs of tuberculosis and other diseases will be deposited in the hay, and being again fed to the cows may have disastrous results in the spreading of disease.

To provide the immense amount of fresh air required by the cows in the barn, careful provision should be made when planning and building the barn. It is, however, not difficult with most old barns to install a satisfactory system of ventilation.

The only practical way in which oxygen can be brought to the cow's nostrils and foul air removed is by correct ventilation, and this requires:

1. That there be a continuous change of air in the stable, so that at no time will there be too much air that has been once breathed. *Authorities set 3¼% of air once breathed as the limit.*
2. There must be no stagnant spots of foul air at any place in the stable—the pure air must be thoroughly diffused throughout the barn, supplying fresh air to each and every cow.
3. This complete change of air and its thorough diffusion throughout the barn must be accomplished without excessive loss of heat.
4. No harmful drafts should strike the cows.

### James Improved Ventilating System

This problem, to a large degree, has been solved by the James Improved Ventilating System. It must be remembered, however, that the science of ventilation, especially as applied to the dairy barn, is by no means perfect. There are factors affecting ventilation that are not yet well understood, and it is not possible for anyone to guarantee 100 per cent efficiency in all cases.

In the James Improved System, the principles of ventilation proven necessary by the investigations of Prof. F. H. King of the University of Wisconsin, and other scientific investigators, are made use of, together with certain improvements developed by Mr. James and his associates. This system may be briefly explained as follows:

Warm air and moist air rise.



Barn of State Prison  
Waupun Wis  
Designed and Equipped the James Way



Barn of R. S. Miller  
Clare Mich. 1910  
Designed and Equipped the James Way



Barn of J. S. Clough  
Warren Pa.  
Designed and Equipped the James Way



The foul air is ordinarily removed from the barn at the floor through one or more outtake flues, the principal reason for so doing being to prevent undue loss of heat, as oftentimes happens when the foul air is removed at the ceiling.

The air at the inside opening of the outtake being warmer than the air out-of-doors, starts an upward current in the flue, just as the kindling of a fire in the stove starts a draft that gradually becomes strong.

This movement is also assisted to some extent by the wind blowing across the top of the outtake, just as a chimney has a stronger draft when the wind is blowing hard.

However, if dependence is placed on the difference in temperature between the air in the stable and that out-of-doors, the system will not always work satisfactorily in the warmer weather.

The James ventilator has been developed to increase the air movement, and make more certain the uniform operation of the ventilating system.

This is accomplished by taking full advantage of the power of the wind, creating a suction that exerts a powerful pull on the air in the outtake flue.

Scientific tests by a competent engineer, as well as tests in actual use in dairy barns, have proven that with this principle in ventilators, 30 to 65% better ventilation is secured as compared with the old wooden cupola and the ordinary ventilators on the market.

Although it is usually desirable to remove foul air from the floor level in order to conserve the heat, it is sometimes found that this method fails to remove enough of the moisture.

That moist air rises is evidenced by the fact that steam, which is air 100% saturated with moisture, always rises. The moisture in a barn will, therefore, tend to collect at the ceiling.

An opening in the outtake flue should be provided at the ceiling to remove this moisture, on days when it is excessive, this opening to be the same size as the opening at the floor, and provided with a slide that it may be opened or closed as conditions may require.

This opening at the ceiling may also be used to remove the warm air in warm weather.

## The Intakes

Every foot of foul air removed from the stable will, of course, be at once replaced by an equal amount of fresh air. The fresh air enters at the ceiling through intakes in the walls of the stable, the inlets of which in the outside of the wall are located about halfway between floor and ceiling. The purpose of this is to "trap" the heat within the stable. The warm air being lighter than cold, cannot get out through the intake flues.



The air at the ceiling being warmest, the fresh air is gradually warmed as it descends.

Where the cows face out, air enters from the side wall near the ceiling; where the cows face in, the air is brought to the center of the barn and enters the stable through the ceiling.

Thus the fresh air always reaches the cows' noses before passing over the gutter, the outtakes being so located that the foul air is drawn out from the rear of the cows. See page 54, 55, 58 and 59.

This principle is a James idea.

By the proper spacing of the intakes and the correct location of the outtakes fresh air is so thoroughly diffused before reaching the cows that no harmful drafts are created, as often occurs when opened windows are used for ventilation.

There are many details, however, that must be observed in order that the system be fully efficient.

Essentials for the success of the system are covered in the following paragraphs:

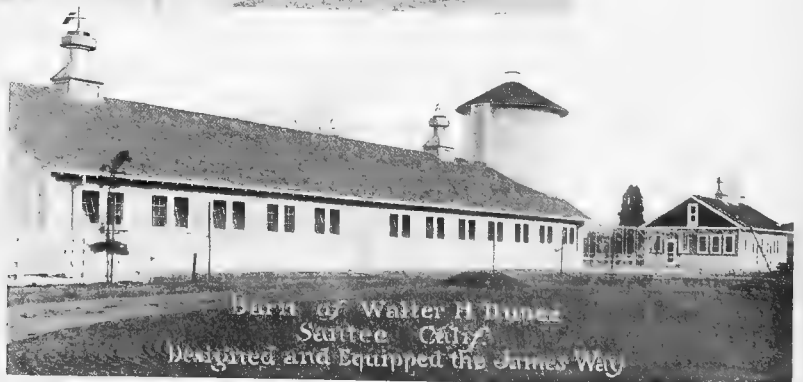
1. The barn walls and ceiling should be as nearly air-tight as possible, consistent with economy; they should also be good non-conductors of heat.

2. The air should be made to enter and leave only through the flues designed and arranged for that purpose; in order that the heat lost may assist in ventilating the barn, haychutes, stairways and other openings should be kept closed.

3. The flues through which the foul air is taken from the barn should be of a warm, air-tight construction, so protected as not to hinder the draft by allowing the outgoing air to cool too rapidly. The foul air flues should be at least twenty-five feet in height; the opening into the flue being about one foot from the floor, in order that the coldest air may be removed, and with an opening of like size at the ceiling for the removal of moist air, should moisture at any time become excessive. These outtake flues should be as straight as possible, with the proper capacity to insure a sufficiently rapid change of air. Outtake flues built on the outside of the barn are unsatisfactory.

4. The fresh air flues, to be most effective should be air-tight, having their inlets outside of the barn, about midway between floor and ceiling and their openings into the stable within eight inches of the ceiling when the stalls face out. Fresh air intakes should be not more than twelve or fourteen feet apart, and should have a joint capacity exceeding that of the foul air outtakes.

5. If the cows face the center of the barn, the fresh air should enter the stable through the ceiling at the center through pairs of registers—one for each side of the barn—the registers in each pair being separated. If the cows face



out, the fresh air should enter through the walls at the ceiling. This brings the fresh air to the cows' noses before it has any chance of being contaminated by passing over the gutters.

6. The foul air outtakes should be so located as to insure a thorough diffusion of the fresh air throughout the stable, leaving no "dead" spots of foul air at the ends, sides or center of the barn.

7. The outside opening of the outtake flue must be properly capped. We have for many years been engaged in the designing of dairy barns which have called for systems of ventilation; and during these years we have been called on to examine hundreds of barns in which the ventilation was not working properly. Very frequently the trouble has been traced to an improperly constructed cupola.

The most frequent fault found is the tendency to make the cupola too small. If the cupola is too small, the system will not work satisfactorily, regardless of how carefully the balance of the system may be installed.

Another frequent difficulty is found in making the cap too low, smothering the draft.

And sometimes trouble is caused by going to the other extreme, making the cap too high, so that the wind blows down the outtake flues, forcing the air out through the intake flues.

One is apt not to understand just how large a ventilator should be unless the subject has been studied very carefully; and when a cupola is home-made, or purchased in a local shop, one is likely to underestimate the size required.

8. Ventilators of correct construction should be used in connection with the system, to secure the added benefit of a forced draft or suction to pull foul air out of the barn. These ventilators should be properly connected to the outtake flues. See page 56.

9. When the barn does not contain the number of animals for which it is designed, the intakes may be partially closed, so as to restrict ventilation to an amount proportioned to the number of cattle in the barn. This is sometimes necessary in a partially filled barn, to keep it from getting too cold. There must, however, be enough cows in the stable to generate sufficient heat to maintain the difference in temperature between the stable and out-of-doors to secure the most efficient ventilation.

### Degree of Ventilation Necessary

Authorities differ as to the amount of air to be provided in a stable, but at the present time they seem well united in considering that when it does not contain over  $3\frac{1}{4}$  per cent of air once breathed, fairly good ventilation would be provided.



Designed and Equipped the James Way



Barn Designed and Equipped  
Silo, Kaeine W. and  
The James Way

MANGLE  
DIVISION  
OF THE  
JAMES  
WAY

Equipped the James Way



Barn of Carl Thompson  
Designed and  
Equipped the James Way



The need of a continuous and sufficient supply of fresh air cannot be over-estimated. To secure good ventilation we have arbitrarily assumed:

1. That the flow of air in a square outtake flue will have at least an average velocity in the flue of 250 feet per minute, without mechanical forcing or the aid of heat other than from the animals in the space ventilated.

2. That the standard of purity of fresh country air contains no more than four parts carbon dioxide in 10,000, and the standard of purity to be preserved in the space ventilated be not over 17 parts of carbon dioxide in 10,000.

3. That average relative humidity of fresh country air is 65% or less.

To secure this air movement, the number of cubic feet of air required per head per hour would be as follows:

TABLE 1:

	Cu. Ft. Per Hour Per Head	Assumed Weights Per Head	
For Horses .....	4,924	1,200 pounds	
For Cows .....	3,953	1,100 pounds	
For Swine .....	1,510	160 pounds	
For Sheep .....	929	100 pounds	
For Hens .....	37	3 pounds	

With different weights per head, the amounts of air would change in proportion.

### How to Figure Sizes of Flues

To ascertain cross section area of outtake flue required to supply this amount, it is necessary to consider speed of air movement through the flue. The area of cross section depends in great degree upon height of the outtake. If outtake is short, it must have a sufficiently larger cross section to compensate for less velocity of air current in the flue, always associated with short flues.

The air movement in outtake flues is also directly affected by difference in temperature and wind velocity; and therefore may vary from 250 to 500 feet per minute.

A ventilating system should be designed of ample capacity to supply the required change of air under most adverse conditions, and provisions made for throttling when the air is moving too rapidly.

Assuming a velocity of 295 ft. per minute for flues 30 ft. high, and 250 ft. for flues 20 ft. high, the size outtake for one cow is arrived at as follows:

Table 1 gives 3953 cu. ft. as amount of air for one cow per hour. Assuming an air movement of 295 feet per minute or 17,700 cu. ft. per hour, the cross section area of outtake to supply one cow per hour is  $3953 \div 15,000 = .223$  sq. ft., or 32.11 sq. in.

Assuming a short outtake with velocity of 250 feet per minute or 15,000 feet per hour, the cross section area for one cow will be  $3953 \div 15,000 = .263$  sq. ft., or 37.87 sq. in.

For 20 cows, the cross section area of 20 ft. outtake flue would be  $37.87 \times 20 = 757.4$  sq. in. or a flue about 20 in. x 38 in. For 30-ft. flue  $32.11 \times 20 = 642$  sq. in., or a flue 20 in. x 32 in.



Barn of State Tuberculosis Sanitarium,  
Terra Alta, W. Va.  
Designed and Equipped the James Way.



Barn of St. Mary's  
Memorial Hospital  
Washington, D. C.  
Designed and Equipped the James Way.



The size outtake for other stock can be arrived at in similar manner.

The combined area of fresh air inlets must equal the combined area of the outtake flues. A number of small intakes gives better results than a few large ones. The smaller intakes, properly placed, give more uniform distribution of fresh air and keep the stable temperature more uniform at all points. If intake flues are made too large, they create harmful drafts. The most practical and efficient size for intake flues, in most cases, is from 80 to 100 sq. in. each, cross section area.

The number of intake flues required can be determined by dividing the combined area of the outtake flues by the size of one intake flue. For example, if the combined area of the outtake flues is 1120 sq. in. and the intakes are made 80 sq. in. each, it will require  $1120 \div 80 = 14$  intakes.

### Registers

As nearly as conditions permit, the effective area of a register or register face should equal the cross section area of the intake with which it is used.

TABLE 2:

Size of Register Face, Inches	Effective Area Square Inches	Size of Register Face, Inches	Effective Area Square Inches	Size of Register Face, Inches	Effective Area Square Inches
6 x 8	32	10 x 10.	66	8 round	33
6 x 10	40	10 x 12.	80	9 round.	41
6 x 12	48	10 x 14	93	10 round	51
6 x 14.	56	12 x 12	96	11 round	62
8 x 8	42	12 x 14.	112	12 round	74
8 x 10	53	14 x 14.	130	14 round	100
8 x 12	64	6 round	19		
8 x 14	75	7 round	25		

### Cubic Feet of Space per Animal

It should be distinctly stated that in matters of ventilation it is cubic feet of air rather than cubic feet of space which should be provided, and in the construction of stables, the amount of space need only be so much as is required to permit ample room and freedom for the animals.

Thirty cows should not be housed in a space much less than 42 x 33 feet, with ceiling 8 feet in the clear. In warm climates there is no objection, except the matter of cost, to high stables, but when it is cold, high ceilings permit warm air to rise so far above the animals as to leave the stable cold at the floor.

### Essentials of a Ventilating Flue

A good ventilating flue should have all the characteristics of a good chimney. It should be constructed with air-tight walls, so that no air can enter except from the stable. Its interior surfaces must be smooth, and it should rise above the highest portions of the roof, so as to get the full force of the wind. It is better to have it nearly straight, when possible, and it should have an ample cross section area. In case of a slight angle in the flue, the cross section area should be increased, to offset the friction loss. Stronger currents through the ventilators will be secured by making one or more larger ones than where many small ones are provided, and it is usually best to have as few as possible. *yet not leave the impure air in distant parts of the stable.*



Barn of P. H. Merrett, Hillsdale, Wis.  
Equipped the James Way.



Barn of A. R. Flick - La Salle, Ill.  
Equipped the James Way.



Barn of H. E. Chase - Framingham, Mass.  
Equipped the James Way.



## Openings to the Ventilator

The outtake flue should be properly coupled to the ventilator and reach within one foot of the stable floor, so that air may come up the shaft from that level. This is very important, in order that the coldest air at the floor be removed during the winter, rather than the warm air at the ceiling. The bottom opening should be made as large as the least cross section of the outtake flue. An opening of the same size should be provided at the ceiling, however, that moist air may be removed when conditions so require.

This opening at the ceiling also provides for the escape of warm air when the stable is too warm, and when it is desired to force the ventilation at the expense of the heat developed by the animals. Both these openings should be provided with regulating valves, so that either or both may be partly or completely closed.

## Entrance for Fresh Air

It will be noted from the different cuts shown, that in all cases the fresh air enters at the ceiling. This is for the purpose of mixing it with the warmest air of the stable, so as to raise its temperature before it falls to the floor. In this way the heat which is rising to and is resting under the ceiling is saved. The entering fresh air forces the foul air down and absorbs the excess moisture, whence it can be carried off by the outlet flue.

Provision is further made for the air to enter the intake outside midway between floor and ceiling, so as to prevent the warm air being drawn out at these places by suction, or to pass out directly as it would if they opened directly through the walls.

## Construction of Flues

A good form of ventilating flue is made of two layers of number one matched stuff,  $\frac{7}{8}$ -inch thick, with building paper or deadening felt between, to make it as nearly as possible a perfect non-conductor, thus preventing rapid cooling of the air in the flue. This form of construction also makes the flue airtight, which is essential, for every hole and crack lessens the ventilating power.

These openings should be placed on both sides of the stable, if possible, in order to take advantage of the wind pressure that increases the draft. It is better to have many small openings than a few large ones, because the cold air is better distributed, lessening drafts. All intake flues should be equipped with registers, so the air is at all times in control of the party in charge. Intake flues may be made of galvanized sheets or wood.

Intake flues should be insulated with a dead air space of one inch, as shown in illustrations A and B on page 62. Unless so insulated, the cold air flowing through the intake flue will condense the moisture of the warmer air of the barn, and the wall and ceiling along the intake flue will be covered with moisture or frost.



Barn Planning Department  
Fort Atkinson, Wisconsin



# James Barn Plan Service

THE James Barn Planning Department is maintained for the benefit of our customers and others interested in the remodelling or the building of good barns.

Whether you intend to build, remodel, or just make alterations or additions—either now or later on—the experience, special knowledge, advice and counsel of this Department is at your service.

The James barn planning service has saved hundreds of dollars each for other dairymen; and if you will take advantage of the benefits which it offers you, you also will save money in the building of your barn.

This department is under the supervision of Mr. W. D. James, now known as the leading authority in the United States on the designing of dairy barns. Mr. James was born and raised on a dairy farm. A lifetime's practical experience has made him thoroughly familiar with every phase of the dairy business, from the cleaning of the barn to the handling of the profits. This, with his experience as a dairy barn designer, and as an inventor and manufacturer of dairy barn equipment, makes his advice of great practical value.

Associated with him in work for our customers is a competent architect and engineer who has had unusual experience as consulting engineer in architectural work, giving special attention to ventilation, reinforced concrete, steel work and structural design.

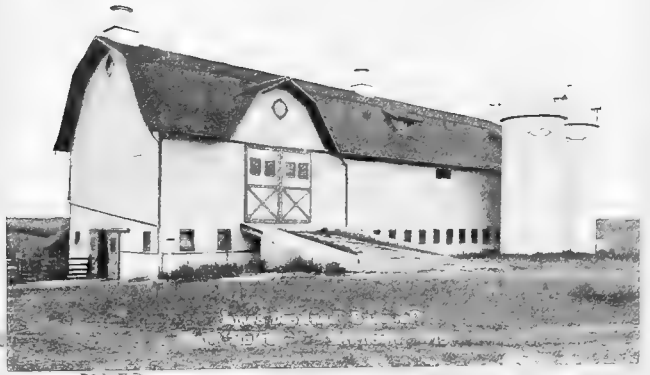
Another architect with years of experience in the planning, building and remodelling of dairy barns, a number of competent draftsmen and several men in charge of various divisions of the field force, complete the office staff of the Barn Planning Department.

In the field are some sixty or more experts whose work takes them daily into dairy barns in every part of the United States, consulting on remodelling and other barn problems, drawing preliminary plans and reporting to the office on new ideas and unusual conditions.

For years, Mr. James and these many assistants have made a careful study of dairy barns—not only how they should be equipped—but how they should be remodelled, constructed, lighted, ventilated, drained—how they should be designed and arranged to be most profitable to the owner.

They have personally visited tens of thousands of dairymen, have inspected their barns, and consulted with them regarding the features most essential to practical dairy stables. And they have talked with large numbers of other practical dairymen on the same subject at dairy shows and fairs.

Every year they furnish plans from which are remodelled or built hundreds of splendid dairy barns and are called upon to solve the barn problems of other thousands of farmers through correspondence and personal consultation in our office and on the farm.



Barn of Charles Blake Belvidere, Ill.



James Designed Barn of Harry Leam Winneconna Wis



Thus the James Barn Planning Department has become a great national clearing-house of ideas on barn building and remodelling.

*JAMES barn plans represent all the biggest and best ideas in all the best barns built in every section of the country.*

We incorporate in the barns we design the most valuable suggestions obtained from the thousands of plans which come before us yearly for our inspection and criticism; so that JAMES service represents not only the original work of James experts, but a knowledge of barn conditions everywhere.

The barns we recommend are plain, practical barns, believing the money is better spent to secure greater space, and better arrangement and convenience inside, rather than on a showy exterior. At the same time James designed barns are well proportioned and pleasing in appearance.

Whether building or remodelling you are offered the benefit of this special knowledge and long experience free of cost and without obligation on your part, excepting that we make a charge when complete plans and specifications are ordered.

We invite you to write us, submitting your ideas or telling us your problems; we may be able to make suggestions that will save you money, just as we have saved money for thousands of your brother dairymen.

The James Manufacturing Company,  
Fort Atkinson, Wis.

2187 East 83d Street,  
Cleveland, Ohio.

"I want to say that I am highly pleased with the plans and specifications as prepared by your architectural department. They are complete even to the smallest detail, and every suggestion or direction which I left with you has been noted. In fact when I remember the multitude of points we considered in our several conversations, I have to wonder how you did it so well.

If your equipment has the same high quality as the service of your architectural department, it will indeed be very satisfactory."

Yours truly,  
W. H. WHITACRE.

"Gentlemen:—The Barn Plans I received from you were very complete indeed. The Builders had no difficulty in following them and must say they were very satisfactory in every particular. The ventilating flues I did not get complete last fall but put them in this summer and they work fine. If they do the work of keeping out the moisture in the cold weather I will be more than pleased for the extra expense of putting them in. I want to thank you for the suggestions you gave me as they enabled me to have a Barn that is a joy and pleasure"

P. O. LEARY, Waterville, Minn.

G. H. Love, B. S., Principal Holmes County Agricultural High School, Goodman, Miss., writes:

"The plans and specifications which you made for us were complete in every detail. I took the High School boys and built the barn with all its equipment except the cutting of the framing, and I am no architect. We have the most modern and best equipped Dairy Barn in the State for its size, and, as said, the Agricultural High School boys did all the work. Our new barn is the center of attraction for all visitors. In fact great numbers of people from this and adjoining counties have made special trips here to the Agricultural High School for the sole purpose of seeing the Dairy Barn, and all are more than pleased with the equipment."

D. M. Dunning, President of the Auburn Savings Bank, Auburn, N. Y., writes:

"Replying to yours of the 15th inst., would say that the barn erected by me this year under your plans, etc., gives entire satisfaction in every way.

"Among a number of large barns erected in this vicinity this year it stands out pre-eminent as a specimen of beauty and architecture, one of the other owners remarking recently 'it has certainly got me skun a mile.'

"Thanking you and grateful for your assistance, believe me,

Very truly yours,  
D. M. DUNNING."



Wm. Larsen Columbus, Wis.



Time Designed Barn of Wm P. Bolden, Balkshus, NY



Barn of Aiken Bros. Waukesha, Wis.



Fleet Dairy Farms Carville, Ill.



H. C. Prange of Sheboygan, Wis., writes: "Replying to your favor of Nov. 15th beg to say, yes, your plans were more than complete. The builder could follow them easily.

"I am frank to say that I can highly recommend your Architectural Service Department."

Nadeau Brothers, Nadeau, Mich., say: "The plans you furnished us for the dairy barn were entirely satisfactory, and worked out as well as we expected, and with the instructions given in your book in regard to putting up the bents made the erection very easy, and our carpenter had no trouble in following out the plans. The barn has proven very satisfactory and the ventilation appears to be perfect, as we have gone through one winter and there was no sign of moisture or frost in the building."

W. A. Schaefer, Minot, N. Dak., writes:

"Received your letter today and seeing you want to know if the plans were complete must say they were in every detail and the carpenter had no trouble in following them. Furthermore he said they were the most complete plans he ever used. And I can say that I have one of the best barns and up to date that there is in this locality. Furthermore all the contractors that figured on the barn said they had seldom seen so complete plans as they were."

PHILADELPHIA, PA.

The James Manufacturing Co.  
Fort Atkinson, Wis.

Gentlemen:—The new fire proof dairy barn which I recently erected on my dairy farm near Reading from plans made by you, has been very much admired.

I am very much pleased with your equipment and can most heartily recommend it as well as your services.

Yours truly,

D. W. DIETRICH.

James A. Craig of the Janesville Machine Company, Janesville, Wisconsin, writes: "I can state frankly that the equipment that I purchased of your Company this year is entirely satisfactory and that the plans you furnished me were very complete, and we had no trouble at all in erecting the barn and equipment in accordance with the plans and specifications submitted by you."

Rosendale, Wisconsin.

Now that we are nearly done with our remodeling job I am in a position to tell you that in my opinion the James equipment is the most sensible, practical and neat appearing equipment that has come under my observation. In connection therewith I also wish to express my appreciation of the high standard of service and the many courtesies shown me by your firm and your Mr. Clark *in assisting me in the plans and layout of the work.*

If at any time I can reciprocate in any way I assure you that it will be a very great pleasure.

JAMES R. HATCH.

THE UNITED STATES OF AMERICA  
**PANAMA-PACIFIC INTERNATIONAL EXPOSITION**  
 SAN FRANCISCO, MCMXV.

CELEBRATING THE 50th ANNIVERSARY OF THE PANAMA CANAL  
 THE INTERNATIONAL EXPOSITION OF 1915

**GRAND PRIZE**  
 upon

JAMES MANUFACTURING COMPANY  
 2065 Mission, Berkeley  
 for Complete Sanitary Dairy Farm Equipment

*Frank*  
 1000 14th St. S.W. Wash. D.C.

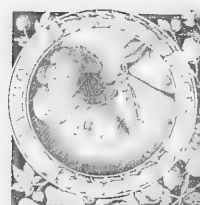
*John C. Banta*  
 1000 14th St. S.W. Wash. D.C.

*Wm. Hallmark*  
 1000 14th St. S.W. Wash. D.C.

*Challinor*

*Walter Gray*

*W. H. Hallmark*



ART SCIENCES

MANUFACTURES

TRANSPORTATION



EDUCATION

AGRICULTURE

MINING



PANAMA

10

10

THE UNITED STATES OF AMERICA - PANAMA-PACIFIC INTERNATIONAL EXPOSITION - SAN FRANCISCO, CALIFORNIA, 1915



## James Equipment Wins Grand Prize

The highest award that could possibly be given on complete dairy barn equipment came to the James Manufacturing Company from the Great Panama-Pacific International Exposition at San Francisco.

In the order of their importance the awards at this Exposition are: Grand Prize, Medal of Honor, Gold Medal, Silver Medal, Bronze Medal, and Honorable Mention.

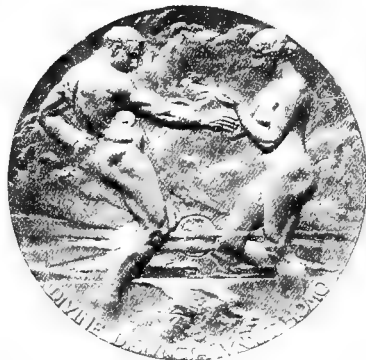
James equipment received the Grand Prize—an award given to but one concern in each line—a recognition that means more than all the others combined, the most eagerly sought award that could be bestowed by the Superior Jury.

Experts of the dairy world had already placed their seal of approval upon James equipment. Its merit—its complete service and high quality—were conceded long before the Exposition opened its gates.

Now this approval is made official by judges eminently competent to perform so important a service for the dairy interests of the country.

In addition to the Grand Prize, Gold Medals (the highest awards covering the specific articles) were awarded the James sanitary cow stalls, stanchions, bull pens, feed carriers, milk can carriers, feed trucks, and litter carriers.

A reading of the following pages will show clearly the reasons for the granting of the Grand Prize and the Gold Medals to James equipment.





IMP BEAUTY 7th

IMP DAVIS 2nd

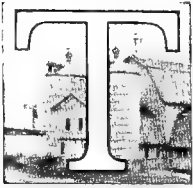
IMP

IMP

IMP

JAY  
MILKING  
MACHINES  
L. S. JAY & CO.  
PHILADELPHIA

# Making Dairy Profits Bigger



THE purpose of the following pages is to show you the easiest way of keeping your cows and their stalls clean; how to save feed and to increase the milk yield; how to keep your cows comfortable while in the barn; how to save bedding; how to improve the health of your cows; lessen the need of hired help and make it easier to get and keep hired help when you need it; make it easier to keep the boys on the farm and to avoid some of the expensive accidents, like abortion caused by strain, and the ruining of a cow by a neighboring cow stepping on her udder; how to save work and save time in the daily chores about the barn; and how to make of the dairy stable a modern, up-to-date food factory of which you may be proud.

In showing you how these things may be accomplished, we wish to emphasize the fact that in reality it will cost you nothing to achieve these ends, excepting the investment of a certain sum of money for a year or two.

The experiences of our customers prove conclusively that James equipment almost invariably pays for itself the first year; but if it paid for itself within three years most men would regard it as an exceptionally good investment.

## Saves Time and Work

The dairy farmer, with his daily round of monotonous tasks in the barn, finds the labor situation one that he must solve if he is to stay in business. One solution is to make machinery do the work—or do as much of it as possible.

James equipment saves work at every turn—when you are putting the cows in the barn and when you are turning them out; when feeding and watering; when milking; when caring for the calves and sick cows; when handling the herd bull; and it saves a very great amount of time when cleaning out the barn and grooming the cows.

By using the James alignment device, the cows are kept lined up at the rear, so that most of the manure falls in the gutter; the floor of the stall is kept clean, the cows do not get covered with filth, and thus a great amount of labor in cleaning the cows and stalls is saved.

The manure carrier cuts squarely in two the labor of cleaning out the barn; with a manure carrier and a spreader, the manure can be taken from the gutter and put on the field with but the one handling—the lifting of the manure from the floor into the carrier tub.

The drinking cups are a tremendous time-saver. A recent investigation among 59 herds disclosed the fact that on the average James cups save  $3\frac{1}{2}$  minutes per cow per day, or about 11 hours per cow, per year. At 25c per hour this would total a saving of \$2.75 per cow, per winter, saved by drinking cups alone.



IMPERIALITY 7

POP DAISY 2

IMPERIALITY 7

IMPERIALITY 7

IMPERIALITY 7

IMPERIALITY 7

JAMES  
SPANISH STEEL  
ESTABLISHED 1850  
JAMES SPANISH STEEL CO.  
P.O. BOX 1000  
PHILADELPHIA, PA.

LOW CLEANLINESS  
LOW CLEANLINESS

The feed truck saves many miles of travel from feed bin to cow.

The ventilator saves time and labor by keeping the air in the stable fresh and pure, so that cows keep in health and less time is lost in caring for sick and diseased animals.

Cow pens, calf pens, bull pens, hog pens, all cut down tremendously the time and work necessary in caring for the stock.

In the hog barn the swill-carrier, and the swinging front panel which keeps the hogs out of the trough until it is filled, save time, labor and bother.

The milk-can carrier is a big time saver in the handling of the milk.

Complete cow stalls save time when putting the cows in the barn and in turning them out; the triple curve stall partition saves time by preventing injury to cows by having a neighbor cow step on the udder; the manger saves time in the feeding; the swinging surestop saves time when putting the cows into the stalls; and the stanchion saves time by keeping the cows tied securely although in perfect comfort.

Even such little items as the scraper, the bull staff, the calf pail-holder, are real time savers.

## Saving Feed

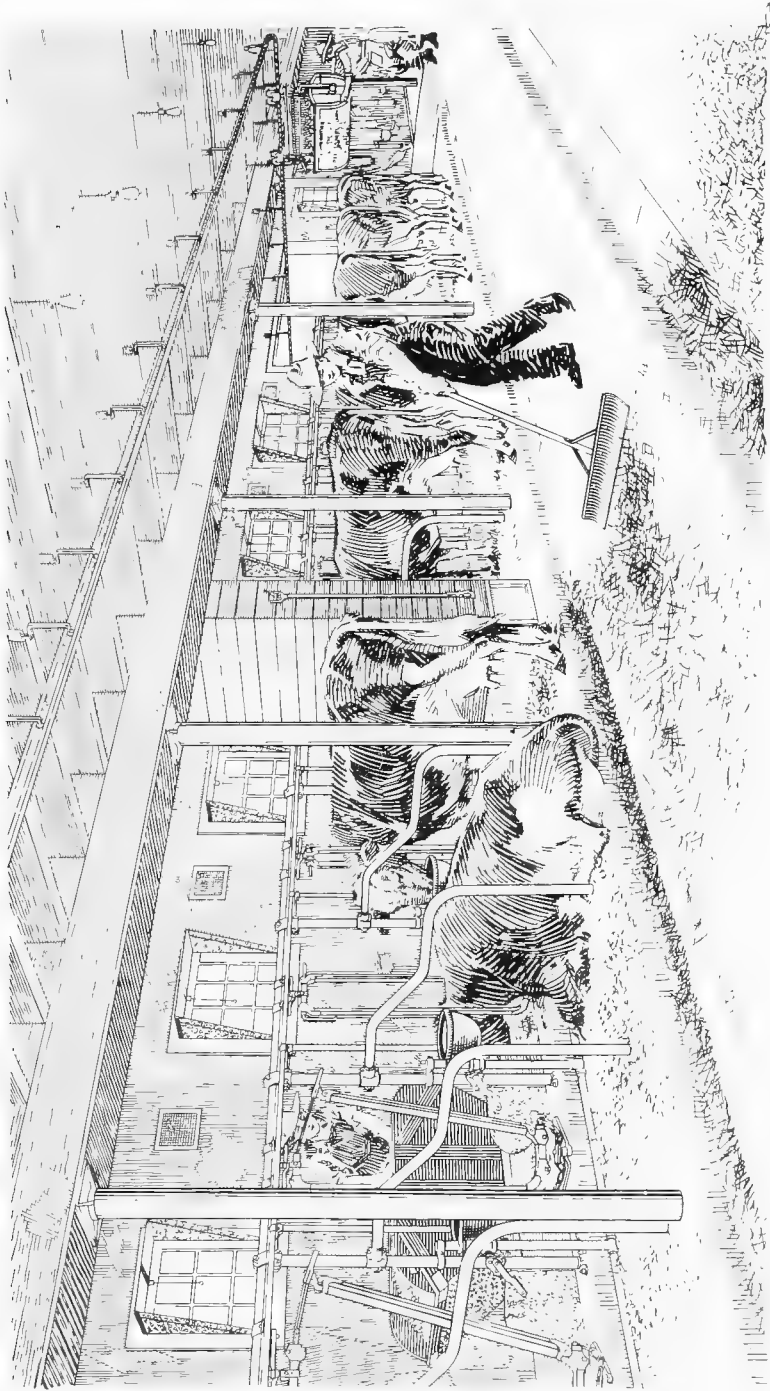
During the past few years, the cost of feed has advanced greatly, and in spite of all that may be done by learning how to use cheaper feeds, it is of great importance that the cow get the benefit of every ounce that is given her.

That's where James equipment comes in again as a money-saver. The high level curb made possible by the James Double Chain Hanger on the stanchion, together with the James Complete Manger, prevents the cows from wasting feed.

Not only that—it makes it possible for you to feed each cow just the amount of feed and just the combination of feeds, that you think she ought to have to produce the best results. Each cow has her own feeding compartment, and a fast-eating cow can't rob a slow-eating neighbor. This prevents one cow getting too much and another too little, with a consequent waste of feed and injury to the cows.

In a letter, Charles Helms of Rose Lawn, Wis., mentions another way in which James equipment saves feed, and others have spoken to us of this same point. He says: "James equipment gives the cows comfort, so they require less feed."

Proper ventilation and correct methods of watering made possible by the James ventilators and the James drinking cups also save feed. When the air is pure and the cows have plenty of water they require less feed per hundred pounds of milk produced.



## Comfort Increases Milk Yield

This matter of cow comfort is extremely important, for the way in which a cow is fastened in the stall has much to do with her milk-producing ability.

The cow that is cramped, uncomfortable, fretted with various annoyances, cannot do her best in making milk.

The cow is comfortable in the James stall; her movements are not cramped in the least; having plenty of head room at the front of the stall she can lie down naturally, and turn her head to card herself, reaching all the way back to her flank on either side. She is almost as free as though in the open yard, yet is tied securely.

How much this matter of cow comfort has to do with milk yield is indicated by the testimony of A. L. Canniff & Sons, Juneau, Wisconsin, who say: "Before we remodeled our building our cattle averaged 32 pounds of milk daily; after we remodeled the building they averaged 39.4 pounds of milk daily, all conditions being equal with the exception of the James Steel Equipment we installed. We attribute this gain of 7.4 pounds to the solid sanitary comfort which our cattle received from the James steel equipment.

The Telling Belle Vernon Dairy Company, Cleveland, Ohio, also report along this line as follows: "The increase in milk per cow was from an average of 19 pounds to an average of 25 pounds (6 pounds increase) per day, at the end of about 3½ months after the installation of James equipment, all other conditions being equal."

H. R. Lobdell, Mukwonago, Wisconsin, says: "Just a few days ago we were forced to take out of our barn part of our milking cows and put them in an adjoining barn with the old wooden stanchions for a few days. They were fed just the same feed and given just the same care but fell off several pounds of milk, per cow, by the end of ten days. They were brought back and at the end of twenty days had gained back to their normal production. I am quite sure that the loss was caused principally by the loss of the comfort of the better equipment and the better barn. The difference was very noticeable in more ways than one."

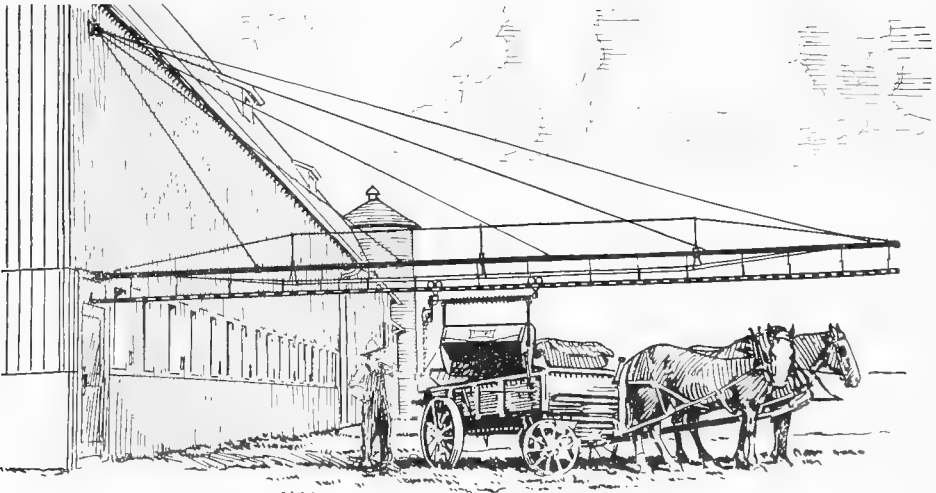
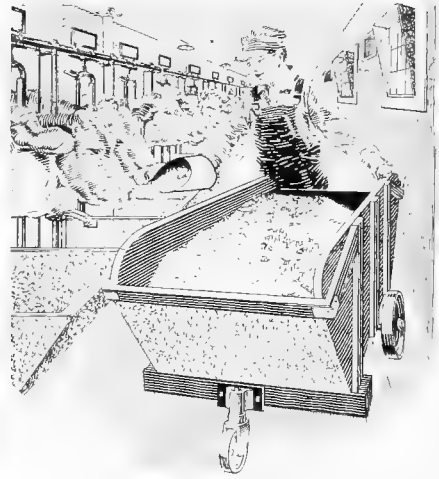
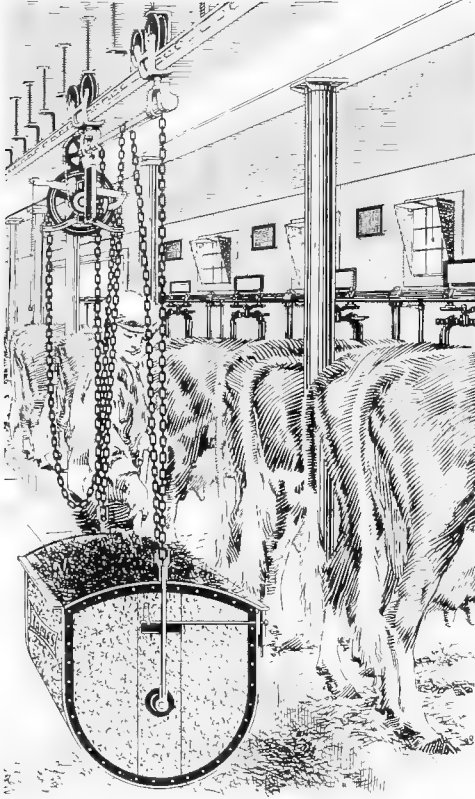
Drinking cups were not in use in any of these cases, therefore it seems fair to assume that the greater comfort and greater freedom of the cow in the James stall was responsible for the increased yield.

Certain it is that cows will produce more when comfortable and will produce less when uncomfortable, distracted or fretted. No other stall equals the James in cow comfort and cow freedom.

## Improves Health of Cows

The cleanliness afforded the cows by the use of James equipment, and the sanitary conditions in the barn made possible, helps maintain better health in the herd—and better health, of course, means more milk, with less money spent doctoring sick cattle.





The James cups giving the cows plenty of water at all hours of the day or night improve digestion and keep the animals in better condition; James ventilators help to keep the stable air fresh and pure; the drinking cups and the manger divisions help to prevent spread of disease through the water and the feed; and the triple curve stall partition helps prevent injury to udders.

You will note from the pictures how little the stalls interfere with light, that there is very little surface on which dust and disease germs can accumulate, and the air has free circulation throughout the barn.

### Saves Bedding

A. G. Abbott, of Wadsworth, Ohio, says that James equipment saves him money "because less straw is required for bedding."

In a stall without a manger, a cow oftentimes tries to get feed which is out of her reach. In straining for it, her hind feet may slip and push the bedding back into the gutter.

Then, too, James equipment, by keeping the manure in the gutter where it belongs, and not on the standing platform or the cow's flanks, lessens the amount of bedding required.

With the cows in James Stalls, the bedding does not have to be changed as often, and this becomes an item worth consideration in the course of a year.

### Higher Prices for Milk

Many dairymen who are selling milk direct to the housewives have discovered another very important feature of James equipment—its use as a means of getting more customers and a bigger price per quart.

People in the towns and cities generally know that milk is one of the best of foods. It is true they do not realize that at the usual prices, it is the cheapest of foods, but this is a fact which can quite readily be demonstrated to them.

The consumption of milk could readily be increased—perhaps doubled—if people fully appreciated its real food value and its cheapness.

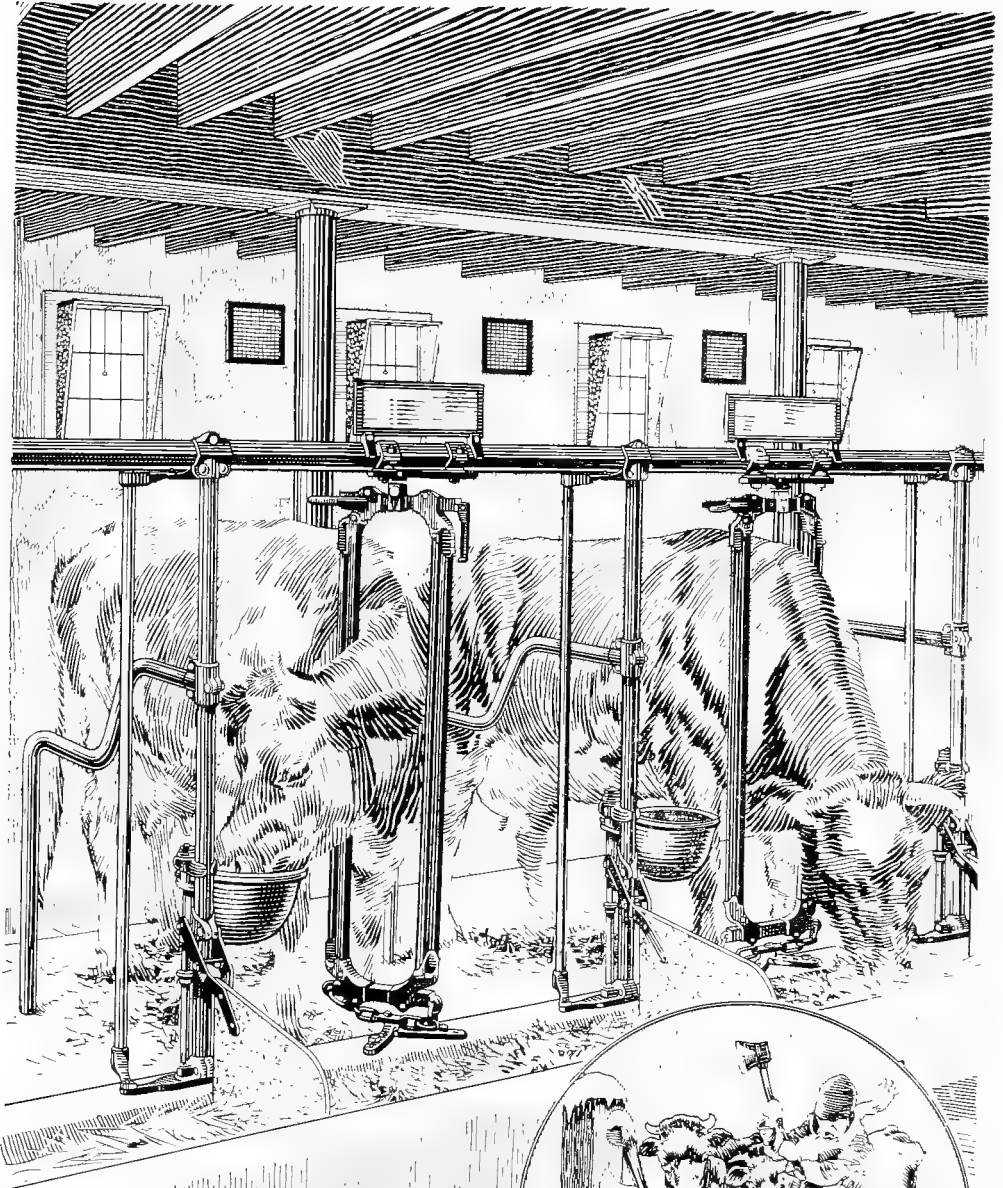
But even without any education on that point, people in towns and cities would gladly use more milk and willingly pay a higher price if they felt sure of the purity and cleanliness of the milk furnished them; and dairymen can increase their business and profits by advertising CLEAN milk.

Read this experience of a practical dairyman as an illustration of what can be accomplished along this line:

Mr. Franklin C. Bron, of Tiverton Four Corners, R. I., wrote us:

"In my opinion, James equipment will last a lifetime, and it saves me money on a big basis. It has increased my business 100 per cent, as I have been recommended by the Board of Health and doctors of Fall River to receive fifteen cents per quart for my milk. The James equipment secured me the highest score by the Fall River Board of Health, which was 97 points for sanitary conditions, the next party to me scoring 73. That amounts to something, as Fall River is a very strict city on milk. I am doing a very good business, and I claim it all through the James equipment."

# The JAMES WAY



The James Way



The Old Way

## Increases Milk Yield

Cow comfort is not the only feature of James equipment that increases milk yield.

Drinking cups, as shown in a recent investigation of 28 herds where milk records were kept, increased milk yields 2.45 lbs. per day per cow, average. This amounts to 490 lbs. a year which at \$3.50 per 100 has a value of \$17.

Besides this, increased milk yields result through less sickness in the herd, and fewer damaged udders.

## Less Need of Hired Help

James equipment lessens your need of hired hands in two ways: It cuts down the amount of work to be done and it makes barn work so much easier that it becomes a task not too great for children's strength.

Mr. S. P. Stevens, of Bartlett, Illinois, says of his experience: "By actual test, two men can better and more quickly care for 90 cows in our new barn outfitted complete by you than the same two men could care for 44 head on the cement floor barn with ordinary equipment we previously used."

Everywhere it is the same story—that James equipment cuts barn work squarely in two. You know how much time is required to do your own barn work and can figure for yourself just what that saving amounts to each year in actual money, or in actual time saved for you.

## Keep the Boys on the Farm

For many years the boys have been leaving the farm and population has been rapidly moving from country districts to cities and towns; in many sections even before the war it had become very difficult to get hired men.

Though wages on the farm have steadily increased and the work made more attractive, the apparently greater opportunity and the allurements of the city continue to draw from the rural population, making it harder every year to obtain the help needed.

James equipment does away with the most disagreeable features of barn work, makes a boy's job of what used to be shirked by all the men, and makes so attractive the work of caring for the cows that the young folks like to do it.

There is plenty of hard labor and enough disagreeable features in farm life at the best; if you do not take advantage of the modern conveniences and labor-saving devices and make dairy farming as pleasant and attractive as working in factory or office, it is to be expected that the boys will become dissatisfied and seek their life work in the towns and cities.

## Be Proud of Your Food Factory

A dairy barn is a factory in which human food is manufactured. James equipment makes possible cleanliness and sanitation, and transforms it into

an institution which you are pleased and proud to have inspected by visitors.

Not only that, but a James equipped barn shows off your cattle to best advantage and helps to get higher prices for any of them that you sell.

### Figure the Savings in Your Own Barn

We have tried to show you in a general way how James equipment will save and make money for any dairyman, whether he has three cows or three hundred, although we have said very little on some points because they are fully covered in pages farther on in this book, but we believe we have said enough to prove our case.

Now take your pencil and figure for yourself the saving in your own barn.

Take the matter of labor, for instance. Thousands of dairymen tell us that James equipment cuts squarely in two the work of caring for the cows.

The saving in time with a herd of 30 cows, for example, is not less than 30 minutes in cleaning out the barn, with a saving of at least 30 minutes in other chores aside from watering. According to the average of reports from 59 herds, James drinking cups save 3 minutes per cow per day, or a total of 90 minutes in a herd of 30 cows. This would bring the total saving up to  $2\frac{1}{2}$  hours per day.

Be conservative; figure labor at 25c an hour. Two hours and a half would be the equivalent of  $62\frac{1}{2}$ c, which in the 200 days or so that cows are kept in the barn totals \$125 per year. This is \$4.50 per cow.

If boys are doing the work—and with James equipment they can do the chores as easily as a man—the saving would be even greater.

Even on this basis and disregarding all other savings and profits brought about by James equipment, a James outfit would pay you a big profit.

Now turn back and re-read the letters of Mr. Canniff, of Telling Belle Vernon Company, and Mr. Lobdell, who speak of the greatly increased milk flow resulting from the cow comfort features of James equipment. They tell of an increase of 7 lbs. per cow, and so on. Be conservative; figure the increase as a result of the greater cow comfort as 1 lb. per cow per day. This is 200 lbs. per cow per year which at \$3.50 is worth \$7.

Add this to the \$4.50 saving in labor. Total \$11.50.

Now, turn over to the section of the catalog telling about drinking cups. In those pages you will find ample proof that James cups bring about big increases in milk yields. Among other proofs is an investigation among 28 herds in which milk records were kept, showing an increase of 2.45 lbs. per cow per day.

Be conservative again. Figure 2 lbs. per day. This is 400 lbs. per year which at \$3.50 is worth \$14.

Add this to the saving in labor (\$4.50) and the increased milk flow resulting from cow comfort (\$7.00). Total \$25.50.

The records of scores of dairymen also show that James cups save on

the average at least 56c per year, per cow, in fuel through doing away with the old bothersome tank-heater.

Add this to the saving in labor, the increase in milk yield, and we have a total of \$26.06.

Now, estimate how much feed your cows waste every day by nosing it back into their stalls, how much feed is wasted by the fast-eating cow taking feed she does not need from a cow that eats more slowly. Assume that James equipment saves only a fourth instead of all this waste in feed.

Add that to the saving in labor and fuel and the increase in milk yield.

Now estimate, if you can, what it is worth to you in dollars and cents to insure better health for your cows by reason of sanitary conditions in the barn; avoiding disease by being able to keep your cows clean, dry and comfortable; how much it is worth to prevent accidents that might cause abortion and the ruin of valuable cows by having their udders tramped on by neighbors or by cows leaving the barn.

If that is worth anything to you, add your estimated saving from this source to the saving of labor, the increased milk yield, the saving of fuel and the saving of feed.

Now, total this up—leave out of consideration all profit received through securing more customers and better prices if you operate a milk route; don't take into account the satisfaction of maintaining a sanitary, model dairy barn; forget about the better prices you receive when you come to sell cows because of their showing off to better advantage in James stalls; omit from your figuring the benefit received by making it easier to get and keep hired help (for hired help prefers every time to work in a barn equipped the James Way); give no thought to what it may be worth to you in helping to keep the boys on the farm; and disregard the protection given you, your hired men and family by having a safe way to handle the bull.

If you figure it carefully you will know our customers are far within the truth when they say that James equipment pays for itself the first year.

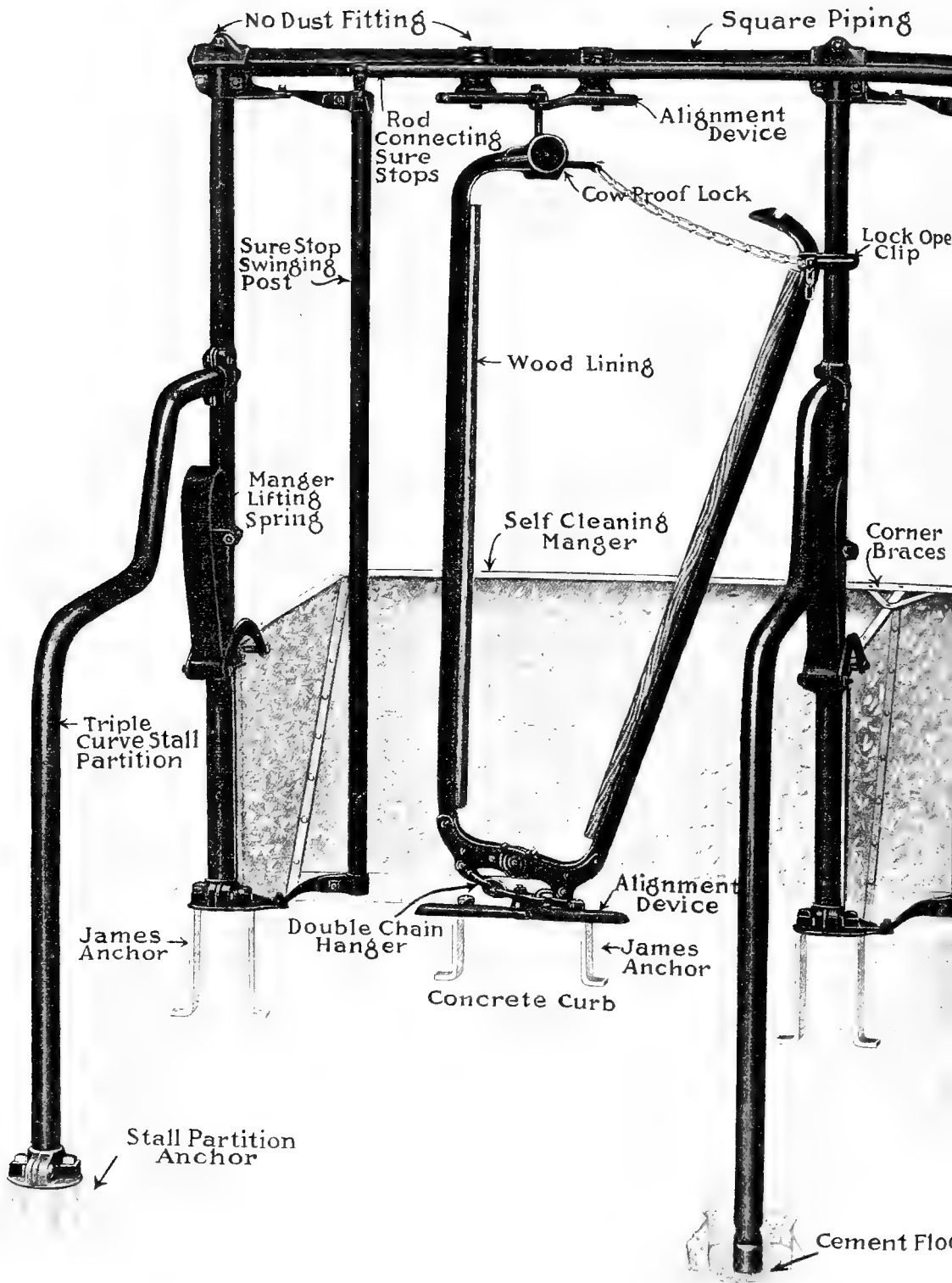
Now, don't you see that whether you buy James equipment or not, you are paying for it anyhow?

*If you haven't James equipment, you pay out the money anyway, in unnecessary cost of caring for the cows in the barn, in wasted feed, in extra help, loss of time, ruined udders, milk that you don't get that you might just as well have had, in needless doctor bills for the cows, and by other losses and waste that would be prevented by James equipment.*

So long as you are paying out this money anyhow, why not have James equipment to show for it?

Why not take this money that is being expended each year without getting anything permanent in return for it, and change it into this James Way investment that will pay for itself the first year and thereafter give you a large increase in your income?

Can you afford not to modernize your barn the James Way?



No Dust Fitting

Square Piping

Rod Connecting Sure Stops

Alignment Device

Cow Proof Lock

Sure Stop Swinging Post

Lock Open Clip

Wood Lining

Self Cleaning Manger

Corner Braces

Manger Lifting Spring

Triple Curve Stall Partition

Alignment Device

James Anchor

Double Chain Hanger

James Anchor

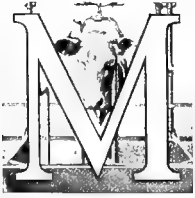
Concrete Curb

Stall Partition Anchor

Cement Floor



# Special Features of James Stalls



OST folks have been used to thinking of a cow stanchion or a cow stall as merely a convenient means of tying the cow. Of course, that is the first purpose—and a stanchion or a stall that permits the cow to get loose in the barn loses most of its value.

James Stalls and Stanchions do tie the cows, all right—tie them so they can't get loose until they are turned loose—but they are far more than mere cow ties.

James Stalls and Stanchions insure profit-making comfort for the cow; increase the yield of milk; keep the stalls and the cows clean; save labor, time and feed; aid in preventing tuberculosis and other diseases; make it easier to disinfect the barn when that task is necessary; prevent accidents that might cause abortion or ruined udders; improve the health of the cows; save bedding; show off the cows better to prospective buyers; and make it easier to get and keep good hired help.

The various savings effected by James Stalls and Stanchions total large enough in a year or two to more than pay the initial cost; and these savings are made possible by the special James features, without which the stall would remain merely a cow tie.

You should, therefore, study carefully the following pages that you may understand clearly what each of these special features will do for you, and how it operates. It will be well worth your while for it will help you to choose wisely the stall that is best suited to your purposes and that will pay you the biggest profit on your investment.

None of these special features are in any sense "fads," but are practical devices that have been developed from actual experience on the dairy farm, to meet the needs of certain classes of dairy farmers.

It may be that your proposition is one that does not call for the installation of all the special features, but that you may select those special features that will help you most to increase your earnings, we have described them as fully as possible, and show illustrations of them in actual use.

## James Sure Stop Swinging Post

(PATENTED)

When the James Stall was invented, it consisted of a swinging stanchion, a stall frame and the stall partition.

Of course, the object of the swinging stanchion was to permit the cow to move her head freely, to rest her head in a natural position when lying down, and to card herself on either side without interference; and to do this required as much room at the head of the stall as at the rear.

$\frac{7}{16}$ " x 2" Carriage Bolt →

↑  
 $\frac{5}{16}$ " x 1" C. B.

↑  
 $\frac{7}{16}$ " x 1 $\frac{1}{2}$ " C.B.

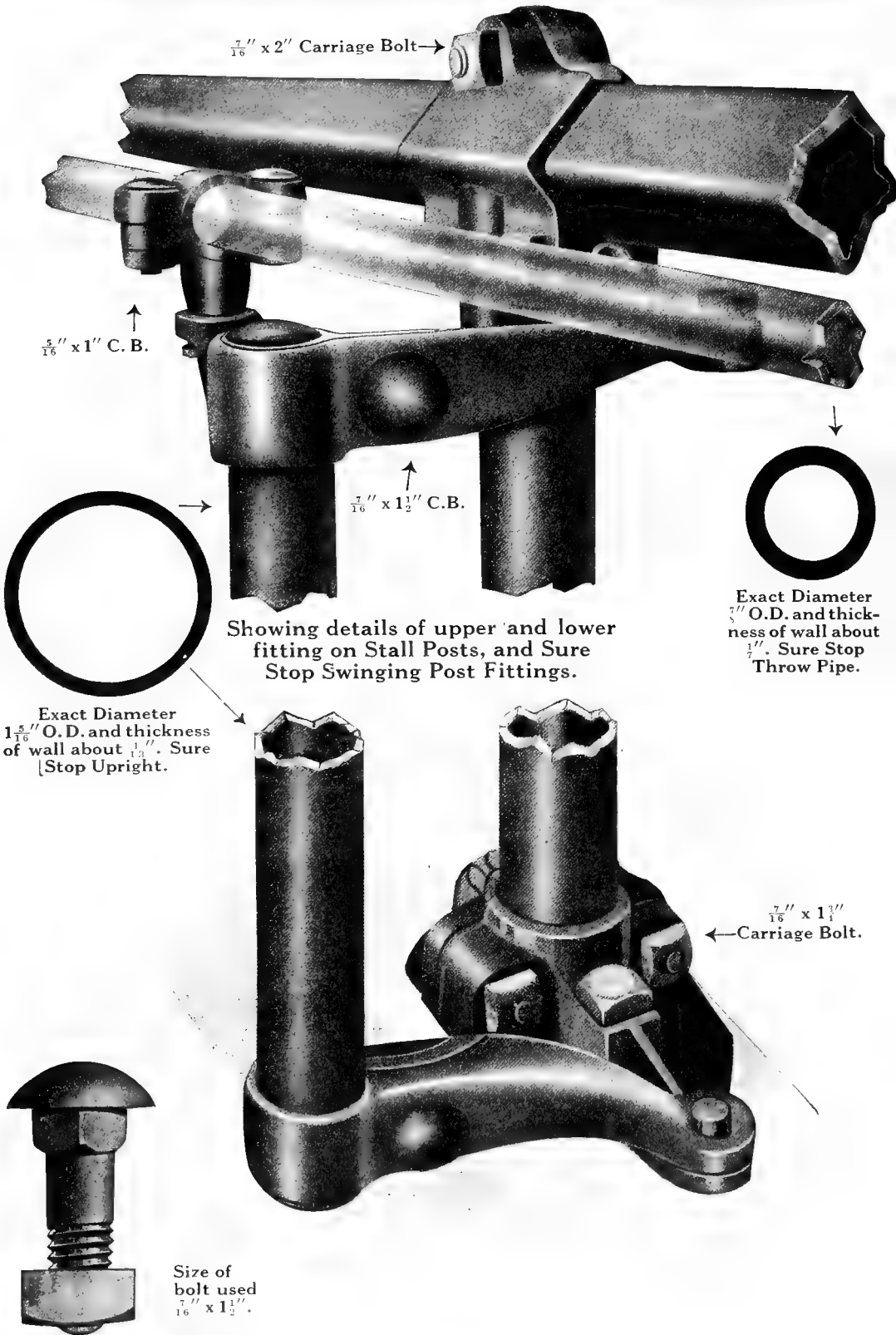
↓  
Exact Diameter  $\frac{7}{8}$ " O.D. and thickness of wall about  $\frac{1}{4}$ ". Sure Stop Throw Pipe.

Showing details of upper and lower fitting on Stall Posts, and Sure Stop Swinging Post Fittings.

Exact Diameter  $1\frac{5}{16}$ " O.D. and thickness of wall about  $\frac{1}{32}$ ". Sure Stop Upright.

←  $\frac{7}{16}$ " x 1 $\frac{1}{4}$ " Carriage Bolt.

Size of bolt used  $\frac{7}{16}$ " x 1 $\frac{1}{2}$ ".



It soon became evident that in giving the cow this freedom and comfort, another difficulty had been encountered.

It is cow nature, when entering the stall, to put her head in the wrong place if she can. And it seems to be human nature for many hired men to sometimes lose patience and abuse the cow. And the owner pays for it with less milk in the pail.

The problem was simply this: A rigid stop was needed between the stationary bar of the stanchion and the stall post, when the stanchion was open; but this stop must not be there when the stanchion was closed.

So the James Sure Stop Swinging Post was devised, and most efficiently has it accomplished the purpose.

The James Sure Stop Swinging Post and Lock Open Device steer the cow's head right into the open stanchion—saving time and trouble.

But when the cow is locked in the stanchion, the sure stop post can be swung back out of the cow's way—giving her plenty of head room so that she can card herself on either side and lie down naturally.

When the stanchions are open, ready for the cows to enter, the attendant, by the simple throwing of a bar, closes the open spaces on one side of the stanchions for an entire row of stalls, no matter how many. It works so easily, a child can handle it.

As soon as the cows are locked in the stanchions, by the same easy movement, all the swinging posts are swung back against the stall partitions, entirely out of the cow's way, giving her unobstructed freedom of movement. She has just as much room at the head of the stall as she has at the rear—and she needs it.

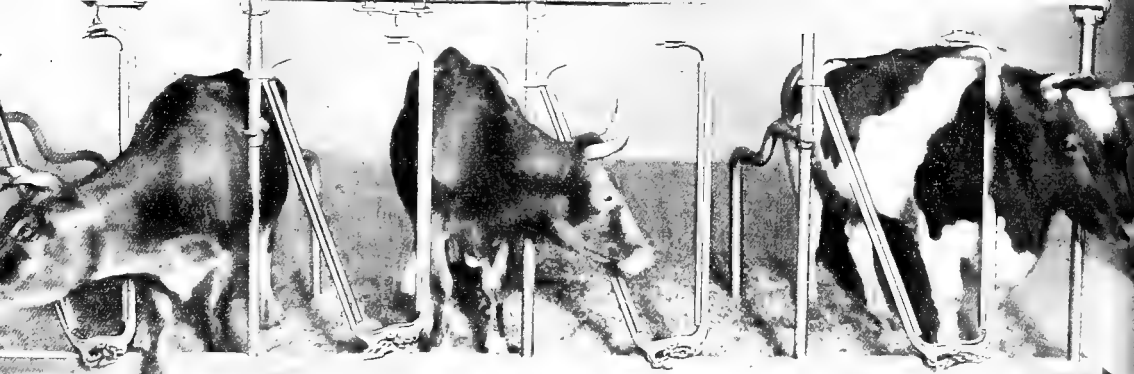
With the James Stall of 3 feet 6 inches in width, the cow has head room of 40 inches, 20 inches on each side of the center of the stanchion.

## The Lock Open Device

The Sure Stop Swinging Post, of course, closes the opening only on the side of the stationary bar of the stanchion; the open arm of the stanchion serves as a stop on the other side.

To prevent the stanchion from swinging when the cow is entering, James Steel Stanchions are furnished with a U-shaped Lock Open Clip which engages the frame of the stall.

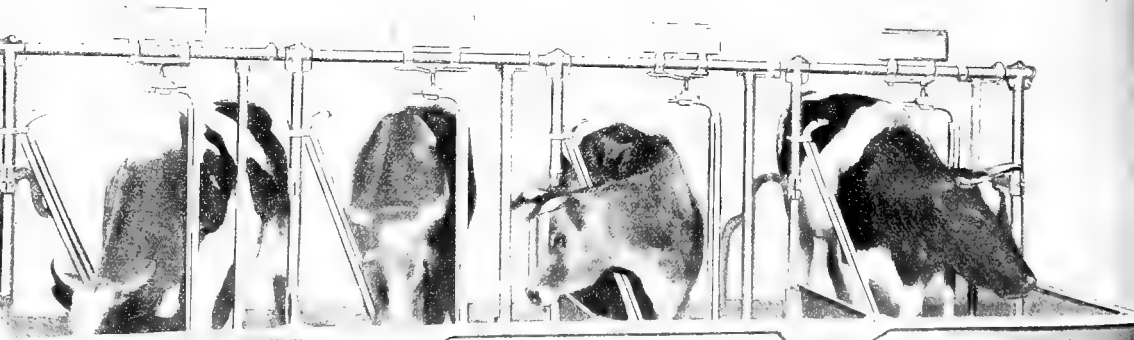
The wood stanchions are furnished with a Chain Lock Open Device which accomplishes the same purpose.



Lack of Sure Stops Causes Loss of Time and Trouble



Rigid Sure Stops Give the Cow Too Little Room

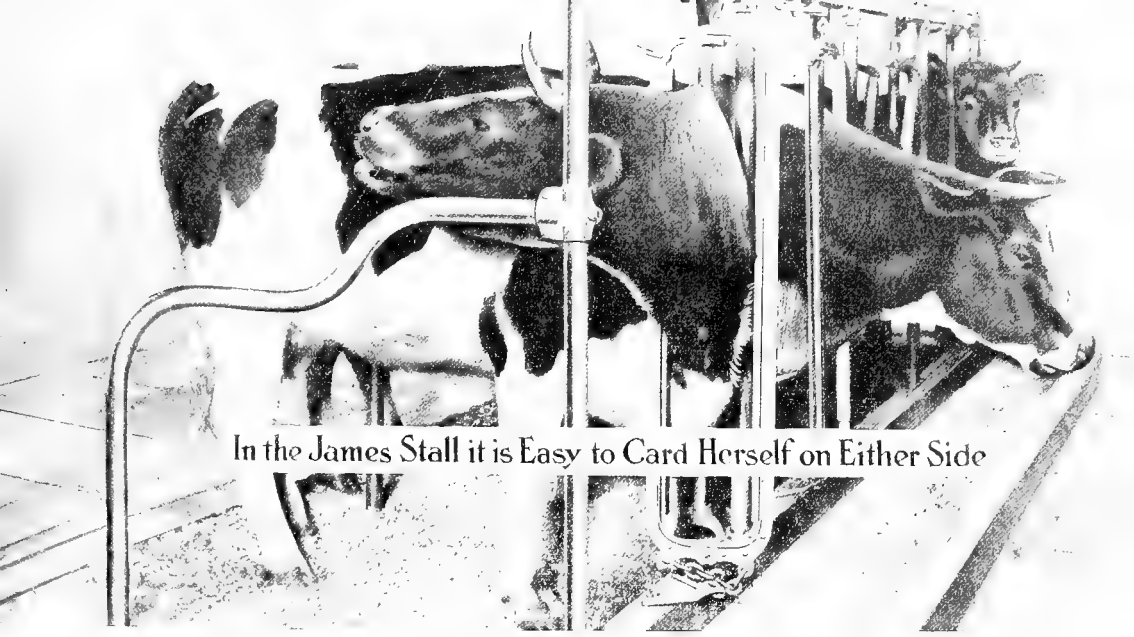


JAMES

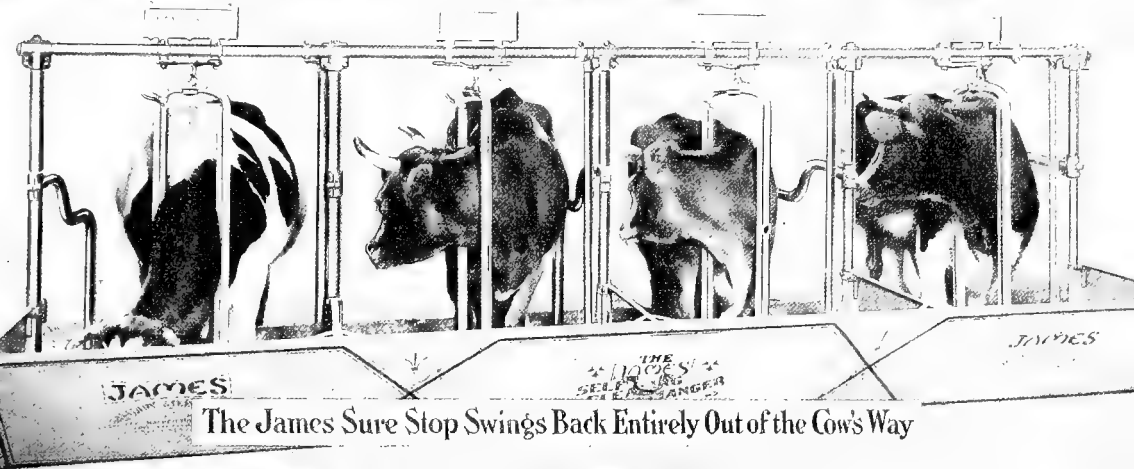
THE SURE STOP  
SELF-LOCKING  
CLEAN MANGER

JAMES

Sure Stop and Lock Open Device Steer the Cow Right



In the James Stall it is Easy to Card Herself on Either Side



The James Sure Stop Swings Back Entirely Out of the Cow's Way





James stalls give the cow as much room at the head as at the rear.

## Wood Linings Are Necessary

The wood linings of the James Steel Stanchions add to the cow's comfort, and, of course, thus tend to increase the milk yield.

The iron or steel, while perhaps actually no colder than wood, feels colder to the touch.

The reason is that steel is a good conductor of heat—it absorbs heat much more readily than wood and gives off heat more rapidly.

Hence when steel comes in contact with the cow's neck, it feels cold and actually does tend to chill the cow because it is continually absorbing heat from her—heat which you furnish feed to supply.

Wood, on the other hand, takes up heat very slowly, being a non-conductor, and hence does not chill the cow.

A little experiment that will illustrate this fact may be made by simply taking hold of a steel pipe in the barn with one hand and placing the other hand on wood.

Note how long the steel will continue to absorb heat, chilling the hand, and how quickly the wood warms to the hand, ceasing almost at once to absorb heat.

Wood linings never become charged with frost—they are absolutely necessary in a metal stanchion if the comfort of the cow is to be considered.

The wood linings of the James Stanchions are made of birch, thoroughly seasoned for two years, carefully milled, shaped and polished; then dipped in oil and kept in the factory six months before used.

Linings are carefully fitted to the steel tees and securely attached.

## The James Double-Chain Hanger

(PATENTED)

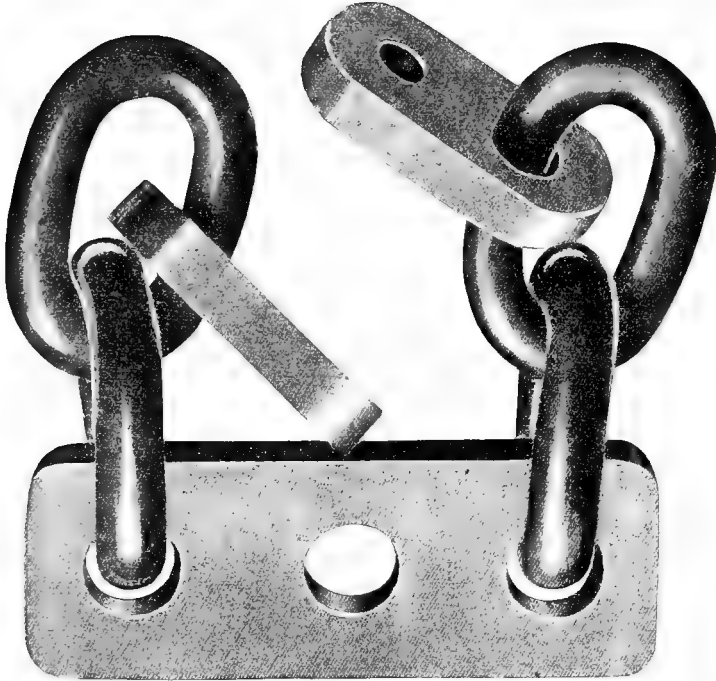
The James Double Chain Hanger enables the dairyman to save money when putting in the concrete floor and rounded curb—saves feed all the time—and lessens labor in taking care of the cows.

When building the curb, a great deal of labor and material is saved if the curb can be built level all the way through the barn. It takes time and wastes material to cut away the curb in each stall; for the wood concrete form must be cut to the shape of the opening desired, and this spoils the lumber for other purposes.

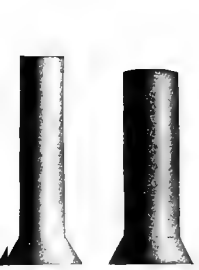
Besides, the cutaway curb disfigures the stall and opens wide a door for great waste of feed.

Before the invention of the James Double Chain Hanger, it was not possible to build the curb level, high enough to prevent the waste of feed without





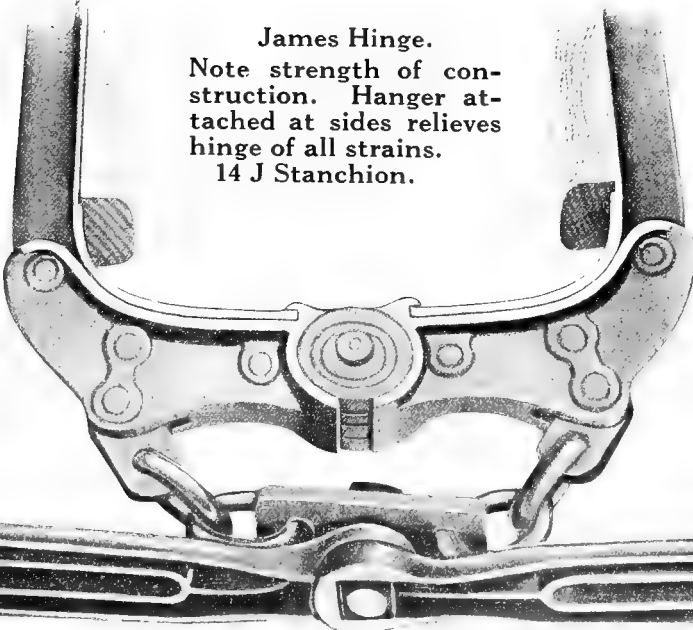
Actual size of James Double Chain Hanger Links.  
Links  $1\frac{1}{8}$ " long inside  $\frac{3}{8}$ " diameter.



Actual size of rivets used.

$\frac{1}{4}$ " x  $1\frac{5}{32}$ " and  
 $\frac{5}{16}$ " x  $1\frac{1}{16}$ "

James Hinge.  
Note strength of construction. Hanger attached at sides relieves hinge of all strains.  
14 J Stanchion.



Actual size of rivet in hinge.

lifting the stanchion so high that it seriously interfered with the cow's comfort when lying down.

To solve this difficulty the James Double Chain Hanger was invented.

It permits the building of a level curb, six inches high, preventing the cow from nosing the feed out of the manger, back under her feet.

At the same time, the stanchion hangs low enough so that the cow's head will be not over 10½ inches above the stall floor when lying down, which is the cow's natural position; and the stanchion has sufficient play to permit the cow to rise without bruising her shoulders.

The Double Chain Hanger also prevents objectionable side play of the stanchion, preventing the cow reaching over into her neighbor's manger.

This James invention accomplishes another important improvement, by separating the chain hanger from the hinge.

The old way was to attach the chain hanger to the hinge itself, thus weakening the stanchion at the point where the greatest strength was required. The hinge got all the strain and leverage, and in time, like a piece of wire bent back and forth, would break.

The James Double Chain Hanger is attached like tugs to a hame—the strain all comes on the side bars of the stanchion and not on the hinge itself.

The links of the James Double Chain Hanger are hung in such a way that it is impossible for the chain to kink, causing wear and a weakening of the links. Where a slack single chain is used the links will oftentimes buckle and kink, just as the links of a watch chain will kink when held slack between the hands and then given a quick jerk. The buckling throws great strain and wear on the misplaced links.

Another advantage of the Double Chain Hanger is the absence of noise.

The Double Chain Hanger is furnished with flat steel links and washers at the points where attached to the alignment irons and the stanchion. The flat steel link lessens friction and resists wear.

## The Hinge

As "a chain is no stronger than its weakest link" so a stanchion is no stronger than its vital part—the hinge.

The hinge in the James 14J Stanchion is almost everlasting. It is a two-piece, interlocking, continuous hinge of best malleable, with a very wide bearing surface which gives it remarkable strength.

It has many times the strength actually necessary; and with the hanger chains so attached as to relieve the hinge of all undue strains, absolute assurance is given that the hinge will withstand the most severe use.

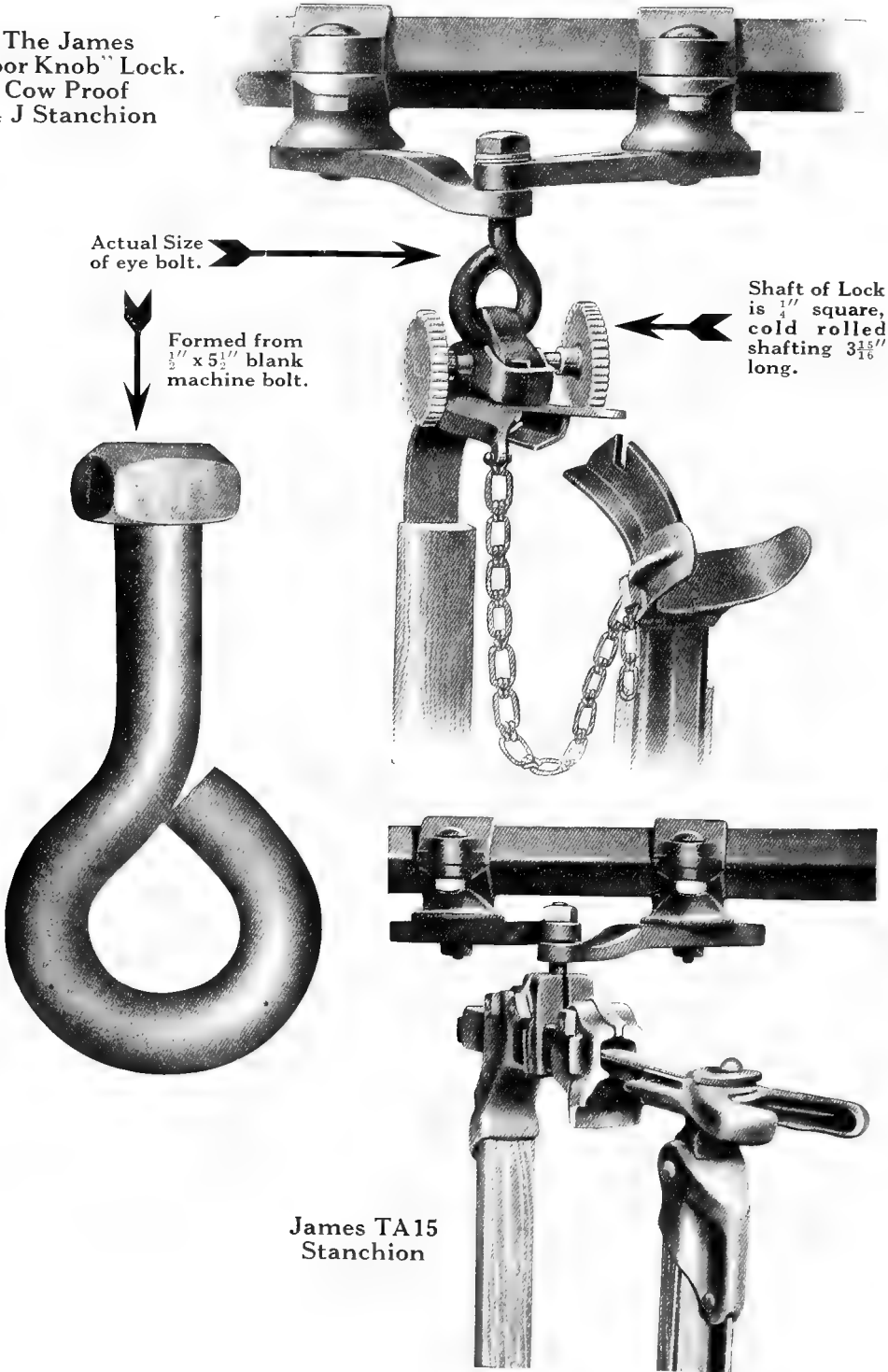
The hinges used in other James Stanchions are different in design but equally strong and efficient.

The James  
"Door Knob" Lock.  
Cow Proof  
14 J Stanchion

Actual Size  
of eye bolt.

Formed from  
 $\frac{1}{2}$ " x  $5\frac{1}{2}$ " blank  
machine bolt.

Shaft of Lock  
is  $\frac{1}{4}$ " square,  
cold rolled  
shafting  $3\frac{15}{16}$ "  
long.



James TA15  
Stanchion

## The Cow-Proof Locks

If a stanchion is to be worth anything at all, its lock must be cow-proof.

A stanchion that a cow can open is a source of danger and a constant cause of trouble.

Only a man who has had the experience knows how big a nuisance a stanchion lock can be when it is not right; for it takes but a very little time for a cow, loose in the barn, to do a lot of damage.

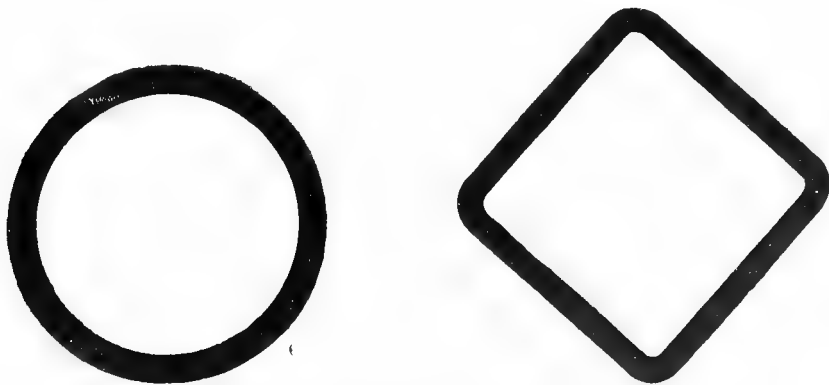
The James Locks are guaranteed to be right in every way, cow-proof—yet easily opened by an attendant even when wearing heavy mittens or gloves. May be opened quickly from the front or from the rear of the stall. Simply slamming the stanchion shut locks it securely.

These James Locks open easily even though the cow throws her weight against the stanchion—yet no cow can open it.

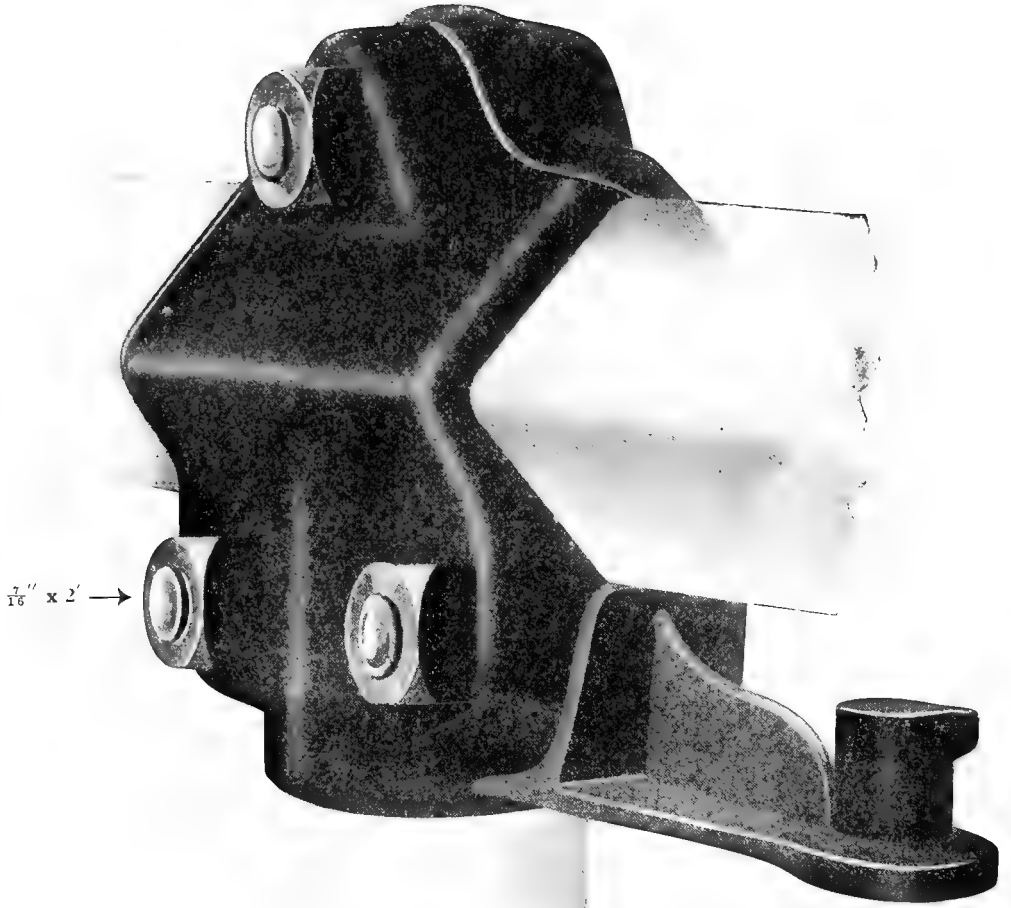
They are safety locks from every standpoint. For economy and efficiency they are in a class of their own and have had much to do with the supremacy of the James Stanchions.

## Stall Frame

The James Stall Frame is made of standard weight pipe,  $1\frac{5}{8}$ -inch outside diameter for the uprights, thickness of wall .14-inch, subject to the usual variation of 5 per cent under or over. The horizontal of the frame is of the same material,  $1\frac{1}{2}$  inches square, thickness of wall .125 inch, subject to variation named above. The square pipe prevents the alignment device from twisting, even when the bolts on the fittings are not drawn tight. If a round pipe were used for the horizontal, the alignment device would twist, dropping the stanchion enough to cause the eye bolt to wear.



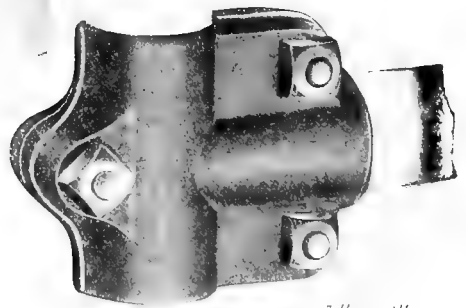
Exact diameter and thickness of wall of Stall Post  
and square horizontal pipe



$\frac{7}{16}'' \times 2'$  →



Actual size bolt  
 $\frac{7}{16}'' \times 1\frac{3}{4}''$



$\frac{7}{16}'' \times 1\frac{3}{4}''$   
Carriage Bolt

## James Sanitary Fittings

(PATENT APPLIED FOR)

All fittings on James Steel Stalls are malleable, of the sanitary type, with overlapping flanges, held together with cut thread bolts of ample size.

The illustrations on page 114 show how the edges of the two pieces of the fitting overlap in such a way that when drawn together by tightening the bolts, no openings are left in which dust can collect.

The openings at the ends of the horizontal square pipe, the ends of the Sure Stop Posts and of the rod connecting the sure stops are also closed with a malleable, sanitary ornament.

The ordinary malleable casting has rough fins or gate marks (where the casting is poured). These are ground smooth on all James fittings.

## James Stall Partitions

A prominent veterinarian tells us:

"Not a week passes but that I am called to treat a cow with a badly injured teat or udder, having been stepped on when lying down, by the cow next to her."

The Telling-Belle Vernon Dairy Company, Cleveland, Ohio, after speaking of the increase in milk yield and saving in labor say:

"Aside from this we have had no damaged udders since the installation of your equipment which of itself is a tremendous saving in the production of certified milk. Formerly, we had to take out many cows, some permanently and others for varying lengths of time, owing to injuries received by adjoining cows stepping on the udders."

George Steiner, Lomira, Wisconsin, writes: "I have not had a teat stepped on like with the old stalls. The James outfit over the old style is better in dozens of ways already mentioned in your book 'The James Way' and to make mention would be needless repetition."

Mr. Chas. F. Welter, Kaukauna, Wisconsin, states: "I wouldn't take double the price I paid for the James stalls and stanchions if I couldn't get any more. The stalls are worth a good lot to save the cows' udders, as in the old way I had two cows that each lost one teat by having been stepped on by another cow."

You yourself have doubtless known many a valuable cow thus ruined.

No careful dairyman will be without stall partitions. They are invaluable protection for both cow and milker, if the partition be of the proper design.

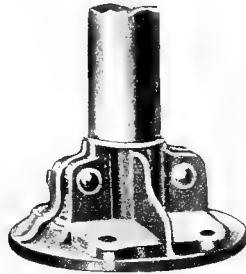
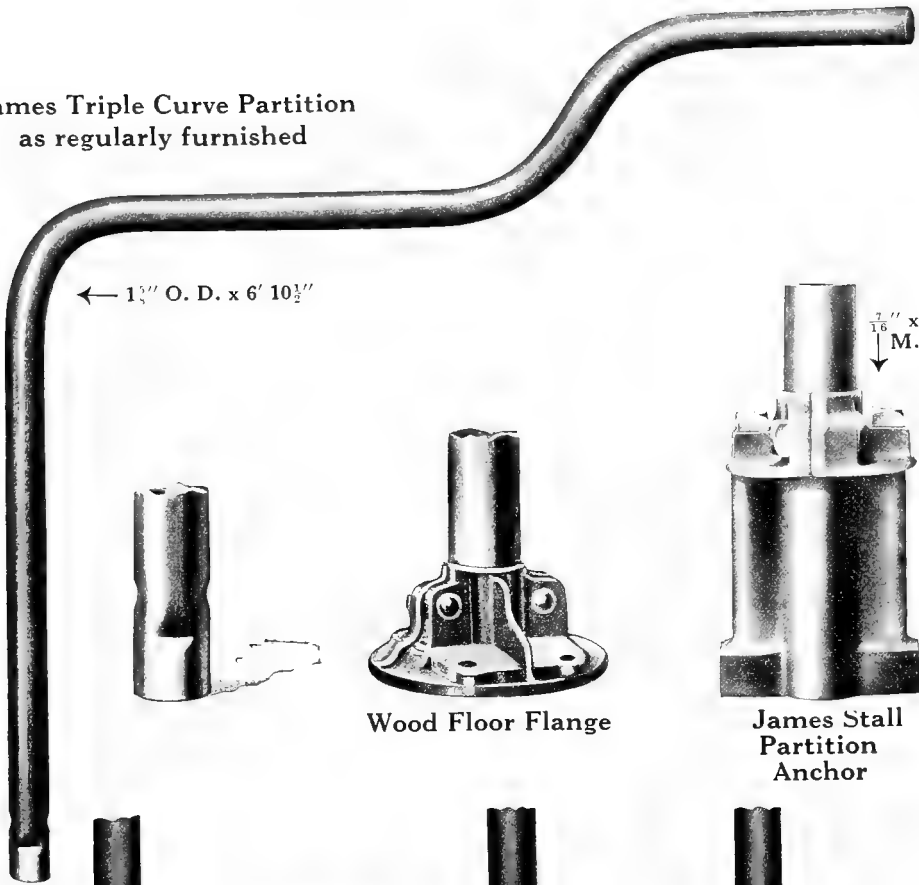
A partition that is too short or that is not of the right shape to afford protection to the cow is, of course, merely a brace for the stanchion frame and is an encumbrance to the stall.

With such a partition, the cow, when lying down, is exposed in a way that a neighbor may tramp on her udder. This happens not only in stalls without any partitions but in stalls where the partitions are short and incomplete.

And, of course, if the partition does not protect the udder of the cow, it will not protect the milker from the cow behind him.

The James Triple Curve Stall Partition, on account of its length and peculiar shape, makes such injuries impossible. It protects both the cow and the milker, at the same time bracing the stanchion frame and doing away with all ceiling posts and supports; keeps the cow from moving away from the

**James Triple Curve Partition  
as regularly furnished**

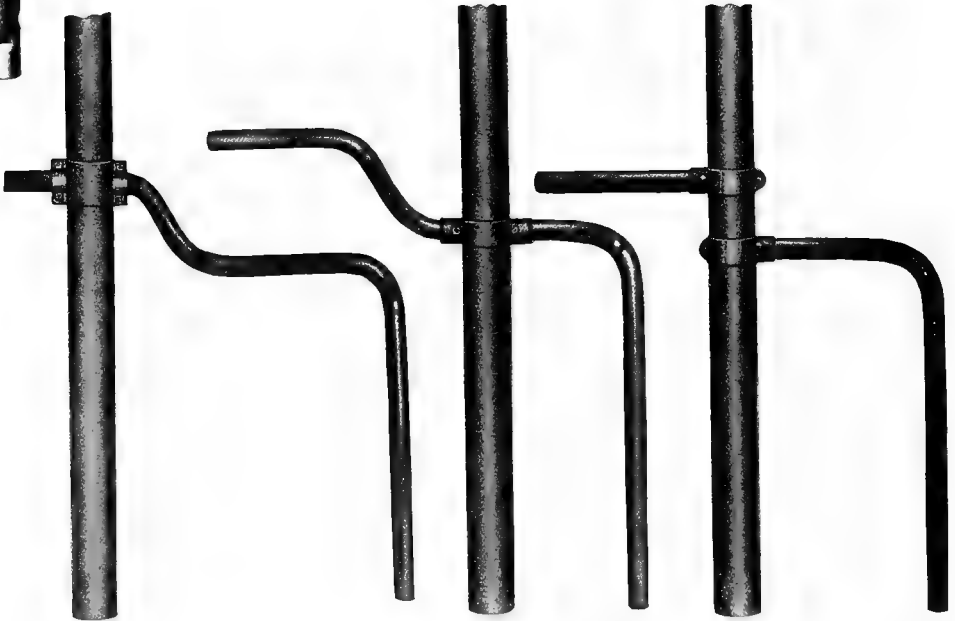


**Wood Floor Flange**



**James Stall  
Partition  
Anchor**

7/16" x 5 1/2"  
M. B.



Extra charge is made for necessary fittings to attach partitions to steel columns 3 1/2", 4 1/2" or 5" in diameter and for cutting partitions to fit. Clamps for other sizes of columns than listed must be made up special from forgings and splicing of clamps, for each of which an extra charge is made.



milker; prevents her from swinging around so that the litter falls on the platform; and prevents two cows from lying down in such a position as to prevent a cow in between them from lying down at all.

The downward curve of the James Stall Partition permits the cow to turn her head and leave the stall more quickly and easily than she can with the single radius partition.

James Partitions are of piping  $1\frac{5}{8}$  inches outside diameter, the length being 3 feet 6 inches. They will neither bend nor break. Length of pipe from which the partition is made is 6 feet  $10\frac{1}{2}$  inches. Furnished with both wood and steel stalls. Fastens to wood stanchion frame with hook bolts and to steel frame with our special malleable fittings. Height of partition can be regulated to suit the breed of cows, by setting partitions deeper in the concrete for the smaller cows.

## James Stall Partition Adjustable Anchors

(PATENTED)

Some have argued that the stall partitions will rust just where they leave the cement floor and for that reason they desired a stall partition anchor that would enable them to replace the partition, or enable them to reset it in the floor.

Others have wanted stall partitions so made as to enable them to adjust the height of the partition to suit the size of the cows occupying the stalls.

We have developed an adjustable anchor that we can recommend, believing that it will withstand every strain and fulfill its purpose perfectly.

James Anchors permit a 5-inch adjustment of the partition up and down in the cement floor, so that the partitions can be set higher or lower at will.

This is done by simply loosening the bolts which clamp the fitting to the partition and the bolts which clamp the partition tee to the stall post; raising or lowering the partition as desired; then tightening the nuts again.

Should you want to remove the partition entirely, you can do it quickly and easily; and it is just as simple a matter to replace it or put in a new one.

Should the partition ever rust at the floor line, the James partition anchor will save you the cost of a new partition; simply loosen the bolts, lower the partition until the anchor gets a grip on the solid metal, tighten the bolts, and your partition is good for many more years of life.

If you want to change the height of the partition to suit the size of some new cows you have purchased, it will take you but a moment—if you have the James anchors.



**Alignment Adjusted for Short Cow.**



**Alignment Adjusted for Long Cow.**

## James Alignment Device

(PATENTED)

The James Alignment Device permits the adjustment of the stanchion forward or backward in the stall, lengthening or shortening the stall to fit the cow. It aligns all the cows—long, short and medium—at the rear, so that manure falls in the gutter instead of on the standing platform.

It keeps the stall clean, hence keeps the cow clean, and saves work in the cleaning of the cow and the stall; lessens the amount of bedding required; and insures a bigger yield of milk because the clean, dry stall affords the cow greater comfort and promotes better health.

The barn is more easily kept in a sanitary condition; and the labor item is reduced to the minimum and the appearance of the barn vastly improved.

If you want to get a line on the labor saving effected by the alignment device, just figure out the time required to groom your cows each day and what that time costs you. You will then better appreciate the fact that the alignment device is the greatest improvement ever made to promote cleanliness of the cow and sanitary condition of the barn and milk.

The James Alignment has seven adjustments, providing not only for seven sizes of cows, but also providing for the same cow in seven stages of growth. It has an adjustment of 10½ inches in all.

The James Alignment Device is patented and because other manufacturers have no right to manufacture or sell such a device they sometimes attempt to persuade purchasers that this valuable feature of the James Stall is worthless—that it will not accomplish its purpose.

There is one convincing answer to all their arguments.

That answer is, the James Alignment Device *is* doing all we claim in thousands of dairy barns right now. It *is* saving time and labor for the fortunate owner; it *is* keeping the cows clean.

You need not take our word for it—read the following letters received from dairymen who are using the James Equipment.

And remember—we also have hundreds of similar letters from owners just as enthusiastic that we will gladly send you. If you want to see them, send us a postal card, asking for these letters; then, should you wish, write to any of them, enclosing a three-cent stamp; you will get an answer.

B. C. Settles, Palmyra, Mo., says: "After a thorough trial of the James Stalls with my cows last winter I want to say there never was a time that I had to clean any manure off their udders."

Edward Van Alstyne, Kinderhook, N. Y., writes us: "I have two-year-old heifers standing side by side with full-aged cows, and both stand just over the drop."

Read this from C. J. Orn, of Barron, Wis.: "James Equipment keeps my cattle clean at all times, and therefore saves time for the men taking care of the herd. Cows also milk more when comfortable."

And this from W. E. Colwell, Kittanning, Pa.: "I find the James Stalls save me money, and my cows have never done better than they have this winter; my cows are all as clean as in summer."

Another letter from Mr. J. W. Breyfogle, Three Rivers, Mich., comments thus: "The Alignment Device saves me time and money. While you take time to wash five or six cows I can milk half that number; since I have had the James stanchions I have not washed the cows, yet they are perfectly clean and ready to milk."



Burn of F. P. LANSING  
Copenhagen, N.Y.



Barn of N. J. Boyd  
Equipped the farm  
Equipped the farm

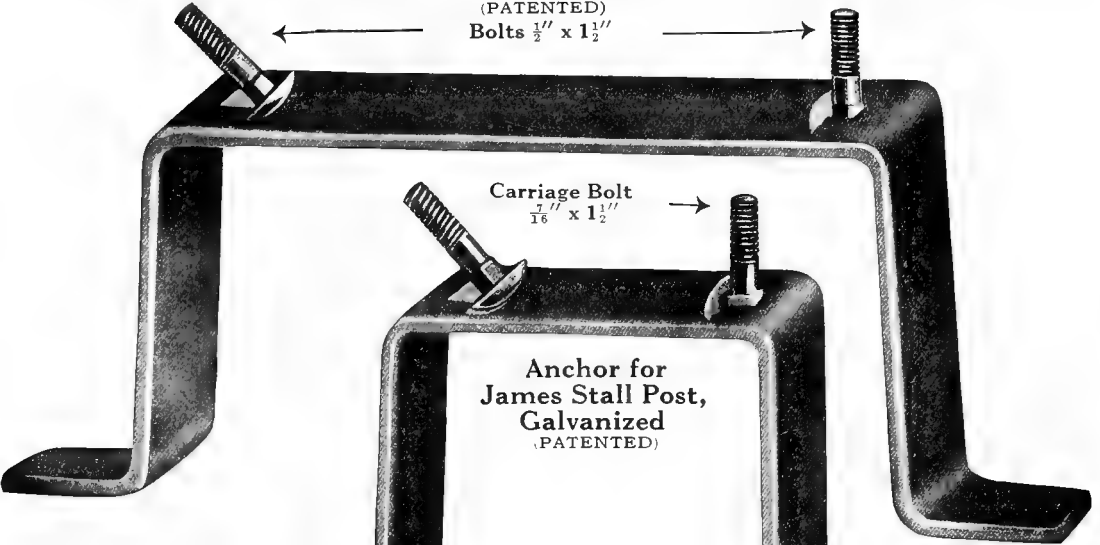


Equipped the farm  
Equipped the farm



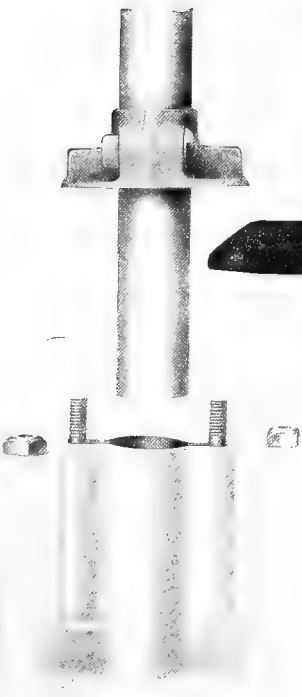
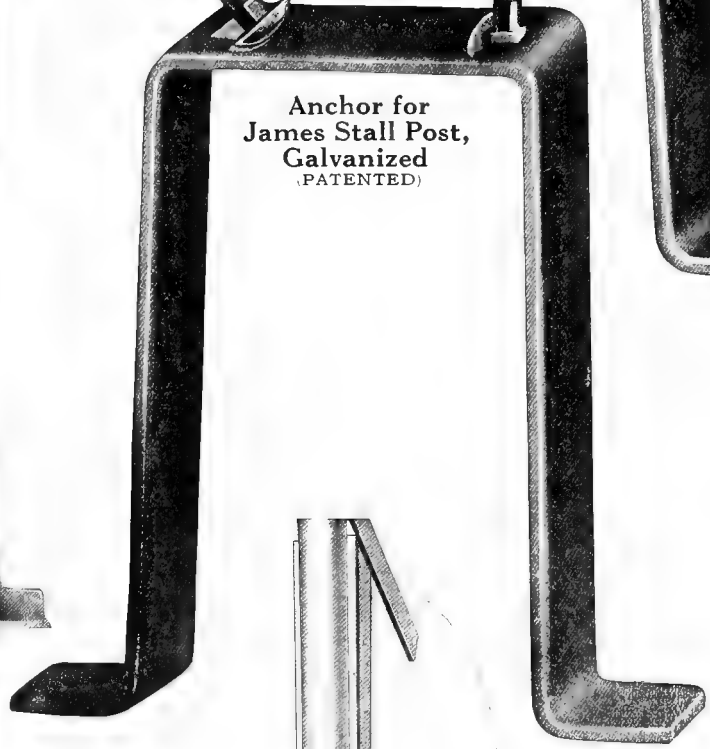
Barn of J. J. Boyd  
Equipped the farm  
Equipped the farm

Anchor for James Stanchion Galvanized  
(PATENTED)  
Bolts  $\frac{3}{8}$ " x  $1\frac{1}{2}$ "

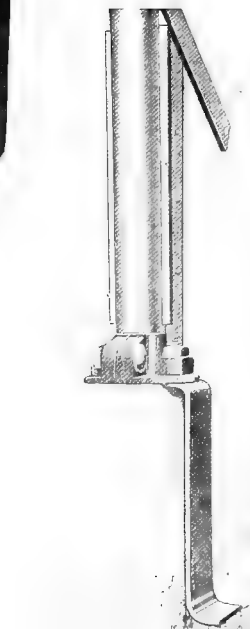


Carriage Bolt  
 $\frac{7}{16}$ " x  $1\frac{1}{2}$ "

Anchor for  
James Stall Post,  
Galvanized  
(PATENTED)



James Anchor  
for Stall Partition  
(PATENTED)



## The Easy James Way of Erecting Barn Equipment

The pictures on the following pages tell an interesting story of the greatest advance in barn equipment, since the time Mr. James first originated the essential features of the cow stall.

It is a plan that reduces the whole proposition of erection to one of absolute simplicity.

This James idea makes so simple and so easy the setting up of cow stalls, and bull, cow and calf pens, that no experience is needed.

It enables any man who is building or remodeling a barn to go right ahead with the cementing of the floor, without waiting for the arrival of the equipment itself.

No delays—no grief while waiting for equipment—no concrete men idle because the material isn't on the ground or because some necessary parts have been lost in transit.

### You Can Start Cementing Tomorrow

The identical principles of barn building and barn equipment that we—as originators—have been presenting to the dairy world from year to year remain as they were.

All the basic ideas that have brought success to barn owners are preserved.

We simply make James Equipment better than ever before by providing a new and easy way of setting it up—a way that makes it unnecessary for you to hire skilled help—a way that makes it unnecessary to delay your cement work or other building operations a single day.

### James Anchors Only Thing Needed

When ready to begin cementing the floor, all you need to have on hand in the way of barn equipment is the required number of James Anchors.

If your cement men are ready to go to work, have them come ahead.

You will be ready for them—The James Way—because you need only James Anchors to begin work.

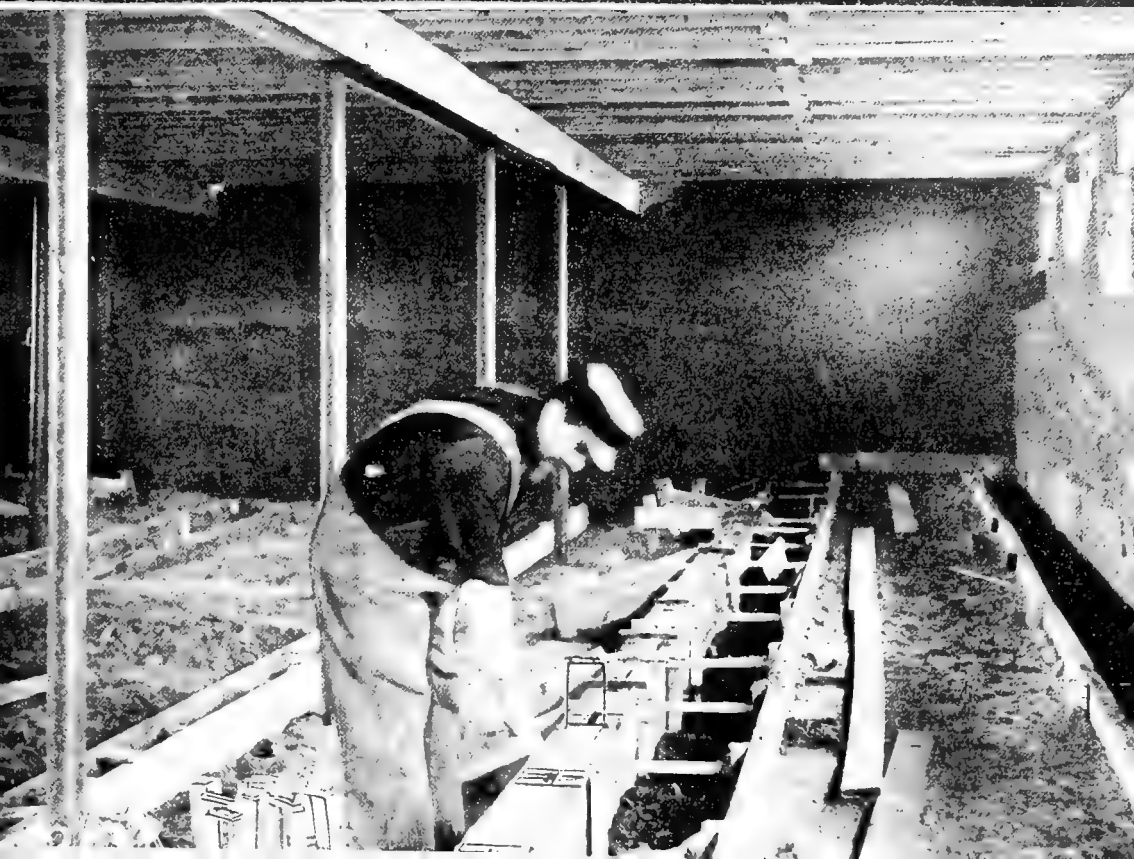
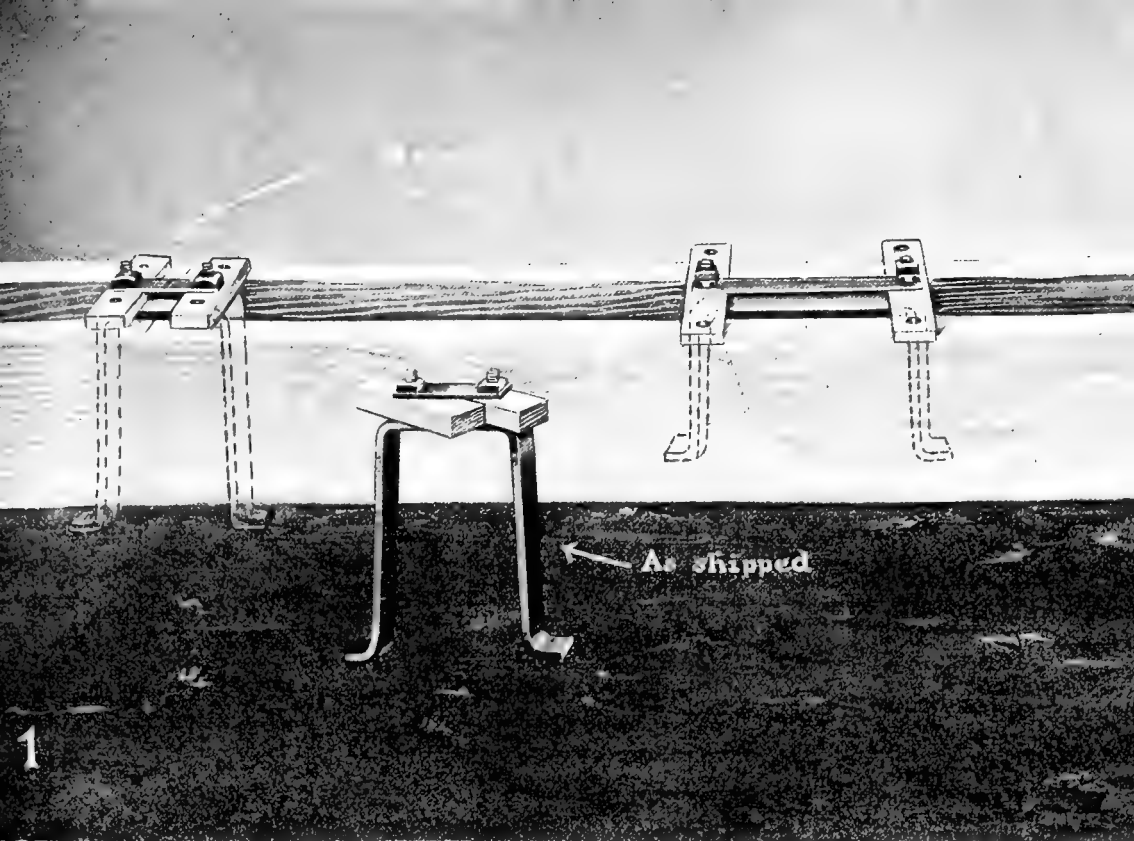
The anchors when you receive them, have templates (anchor spacers) attached—the templates being scored and marked, with nail holes already drilled.

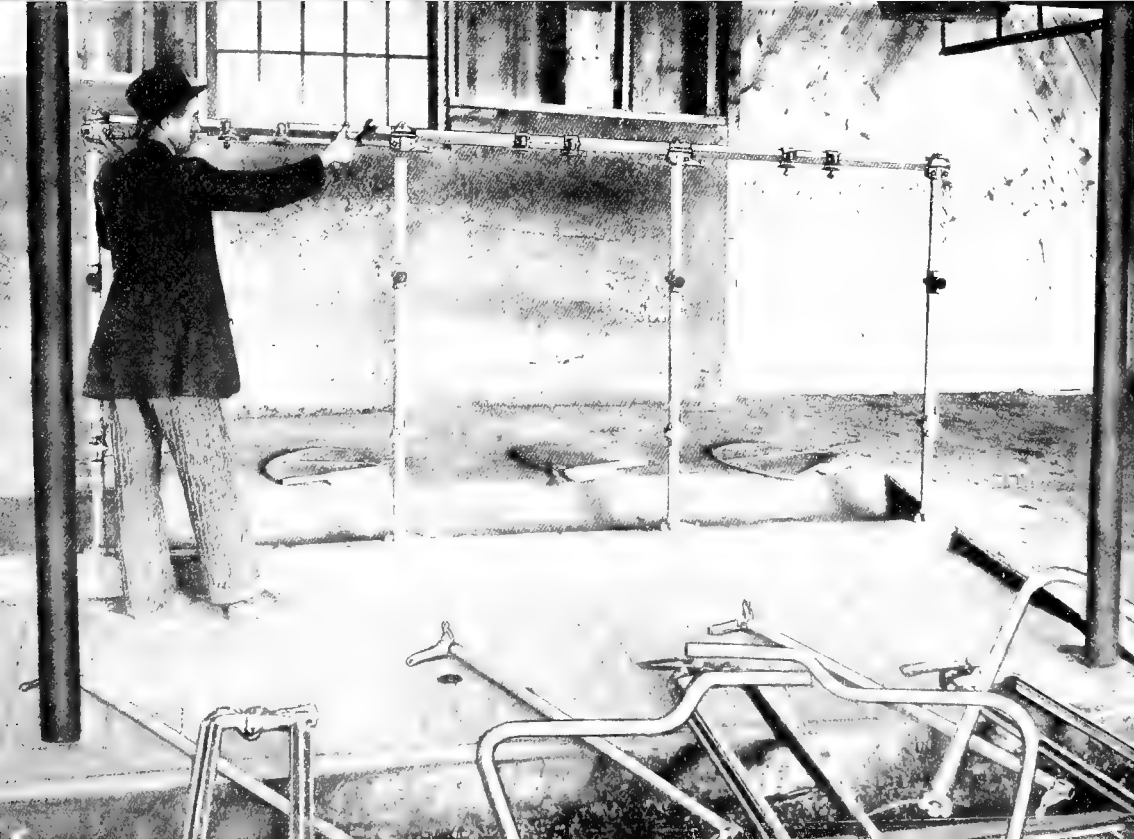
You mark off the proper spacing on the form for the concrete curb, according to simple directions furnished with each job.

The anchors—which later are to hold the stall posts and stanchions—are set in the form at the proper points, nailed in place and the form filled with concrete.









You can then go ahead finishing up the cement floor. The stalls and pens may be set up at any time later when most convenient.

When the concrete is set, the templates are removed and thrown away and the stalls may be quickly bolted into place.

On account of the shape of the anchors the curb is less liable to be cracked by the expansion and contraction of the metal than it is when the upright pipe extends through the concrete curb.

## Assembled Stalls—Knocked Down for Easy Handling and Convenience in Erection

No boxes filled with small parts—no long lists of little pieces—no complicated directions—no difficult checking to see whether you are short anything.

Instead, the equipment reaches you assembled—the fittings bolted in their proper places on the stall frame. To put the stall together, you simply loosen the bolts in the tee fittings, insert the uprights, stall partitions and other parts of the stall—then tighten the nuts.

You can't go wrong in erecting James Equipment. No expert help is needed. One man can do it all, and the work of erecting is so simplified that it takes but a very short time.

## Quick Shipment of Anchors

You can get the anchors immediately—by express if you need them at once—From Fort Atkinson, Elmira, Minneapolis, Wright Ziegler Co., Boston, De Laval Dairy Supply Co., San Francisco, or from some nearby distributing point.

For the convenience of our customers and to provide quick service, stocks of James Anchors will be carried in many places throughout the United States.

Almost without exception, regardless of where you live, it will be possible to deliver the anchors to you at your express station within twenty-four hours, should you need them that quickly.

## Setting Up the Stalls

Even in the pictures it is difficult to show how simple it really is to set up the James stalls and pens. All the fittings are put in place on the stall posts, partitions, horizontal bars, sure stops and sure stop connecting rods at the factory, before shipment. You have no searching to do for proper parts—no lost parts—everything is simplified so that a boy can understand it all.

Picture No. 1 shows the anchors with templates attached set in the concrete curb form, ready for the concrete to be poured.

No. 2 shows anchors in place and the form filled with concrete.



No. 3 shows a man attaching stall posts to the bolts in the anchors in the concrete curb.

No. 4. The square horizontal pipe is next put in place on the stall posts and the nuts tightened.

No. 5. Attaching the stall partitions—one end being bolted to the stall, the other imbedded in the floor, or bolted to the partition anchor, if the anchor is used.

No. 6. The stanchion is easily attached to the anchor provided for that purpose, and to the fittings on the square horizontal pipe.

No. 7. The sure stop swinging posts are quickly hung on pins which form part of the fitting at the top and at the bottom of each stall post. This is more clearly shown on page 114.

No. 8. The rod connecting the full line of sure stops is easily attached to the sure stop posts.

No. 9. The manger division is easily put in place.

No. 10. When complete manger is ordered, the manger lifting springs are put in place on the stall posts before leaving the factory.

No. 11. The manger is shipped knocked down for convenience in handling. The manger front and manger partitions may be quickly bolted together without difficulty and manger attached to the hinge fittings on the stall posts.

No. 12 shows how the manger and stall look when complete.

## Erecting Pens

Setting up the James Pens is just as simple, it being necessary to set only the panel supporting posts and gate posts in the tubular anchors and bolt the panels to the posts.

Herman Olson, Cambridge, Wisconsin, says: "James equipments are unbeatable; with the high-class materials and carefully adjusted fittings, it really is a pleasure to install them according to the blue print directions, as everything goes together so precisely correct with the diagram."

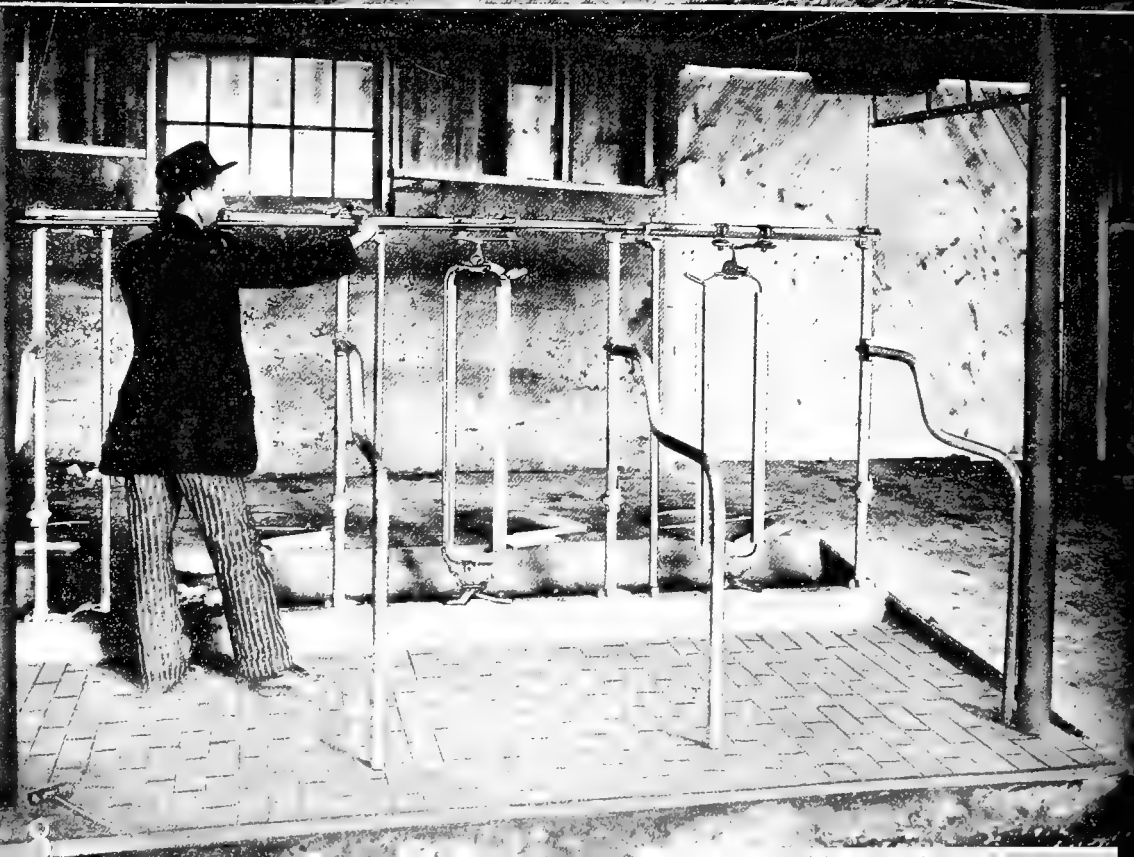
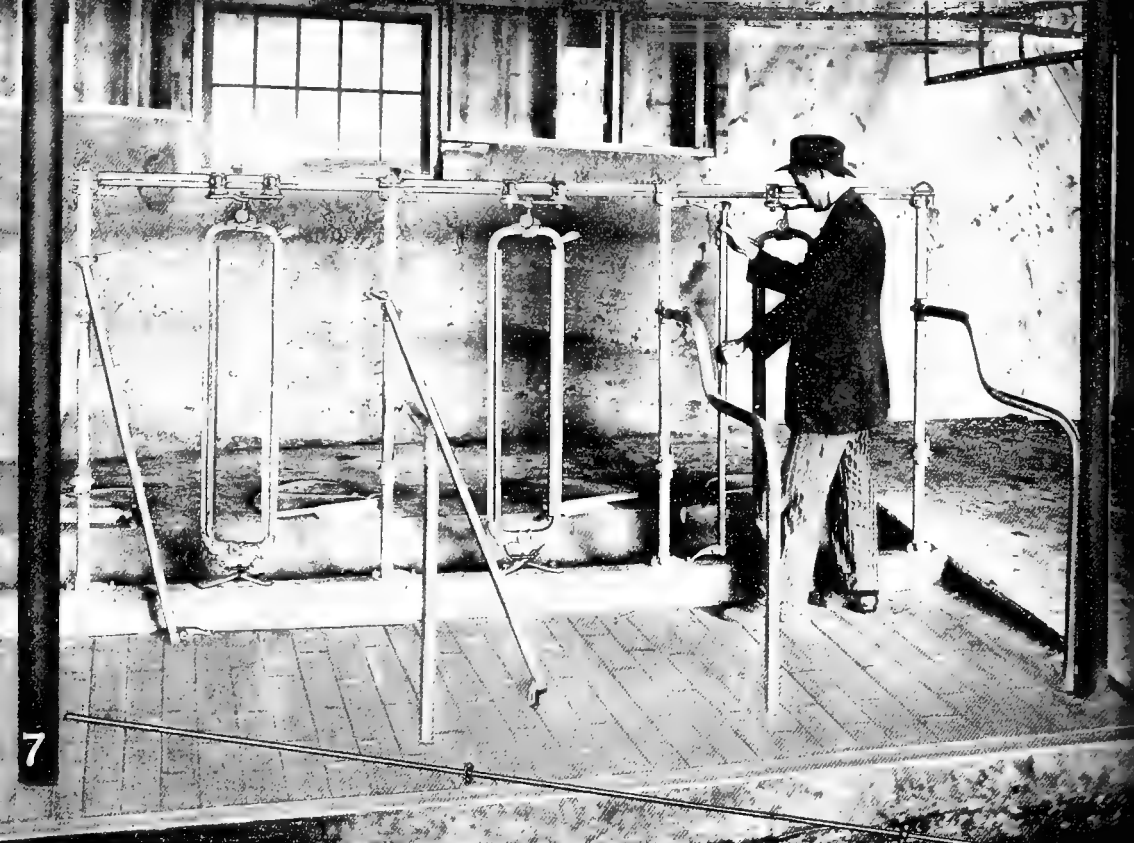
Mr. George Steiner, Lomira, Wisconsin, writes: "I am a James booster all the time because I have faith in the goods and the Company and everything fits according to the plan to a dot. A neighbor bought another kind of equipment and nothing fits. The plan was not a plan at all. It was a fake."

Robert J. Porter, Harmarville, Pa., says: "My father bought the James sanitary stalls and he is very well pleased with them. I am 16 years old and I put them all up myself without the help of anyone. The day they came, I went to the station and got them and had all but the mangers on before he saw them. I followed your directions and found it very easy and am mighty proud of them for they certainly are great."

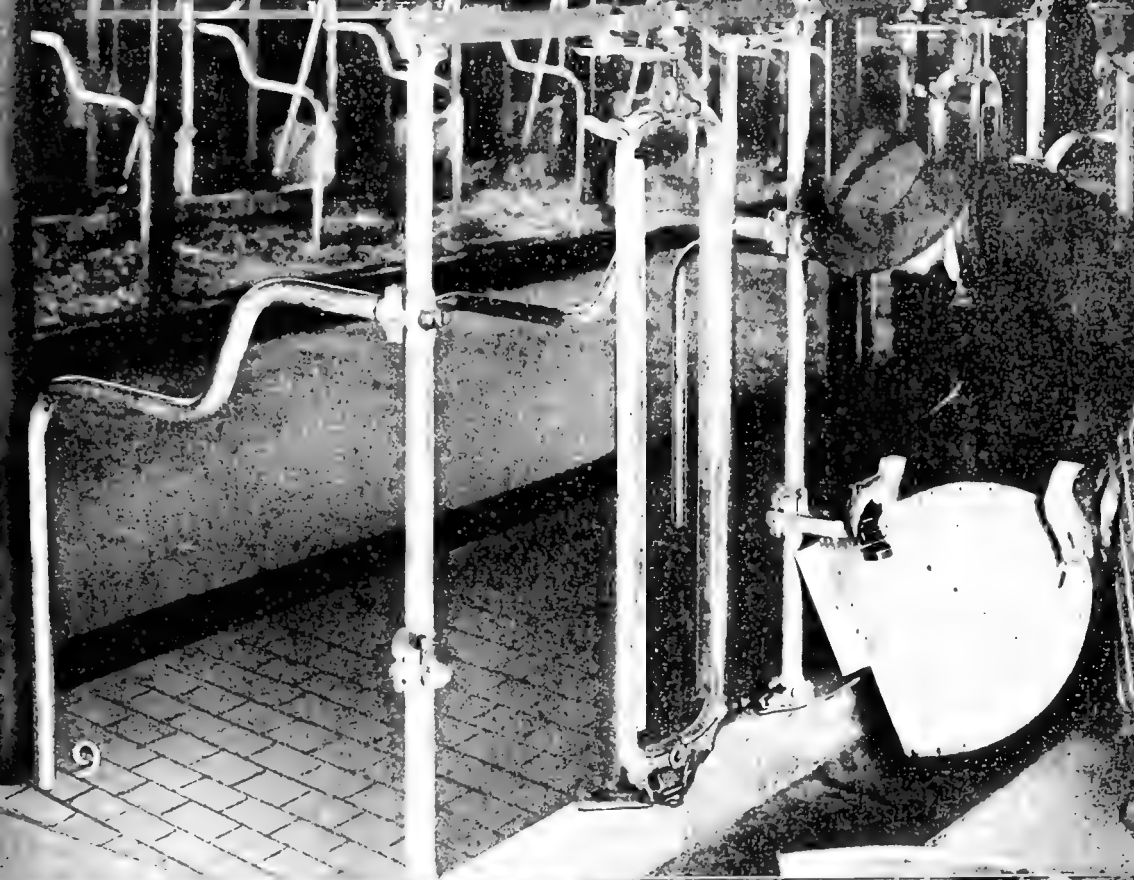
## How James Equipment is Finished

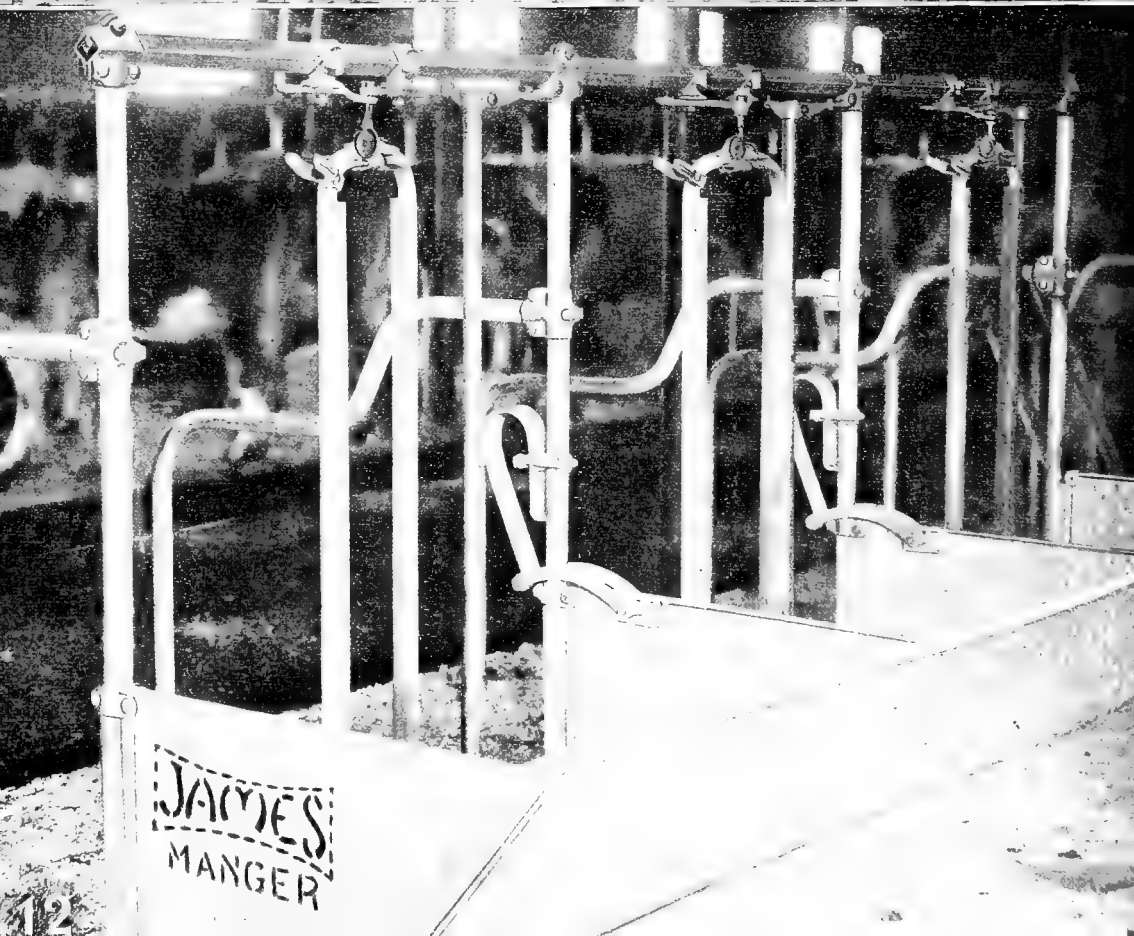
All metal parts of James stalls, stanchions and pens, are first mechanically cleaned, removing scale, grease and foreign matter, thoroughly preparing the material for painting.











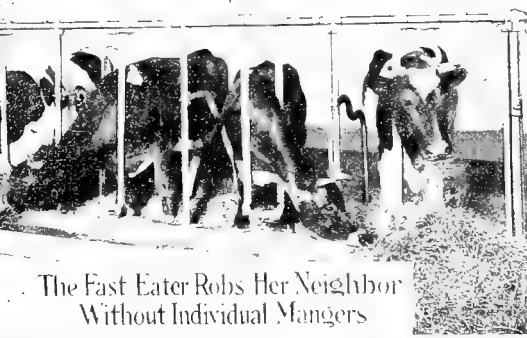
It is then finished with the best gray protective enamel made expressly for us under our own formula, based upon a thorough investigation, numerous tests and research work for the best enamel to be used on dairy barn equipment. After applying this enamel on the clean metal, it is thoroughly baked for two hours at a high temperature.

The elastic yet hard surface of the enamel, baked on, gives a lasting protection—one that will resist blows without flaking off. The color of the finish is known as battleship gray, this color being most suitable because it gives a handsome finish that will not soil easily, helps to make the barn brighter, and has exceptionally high protective qualities.

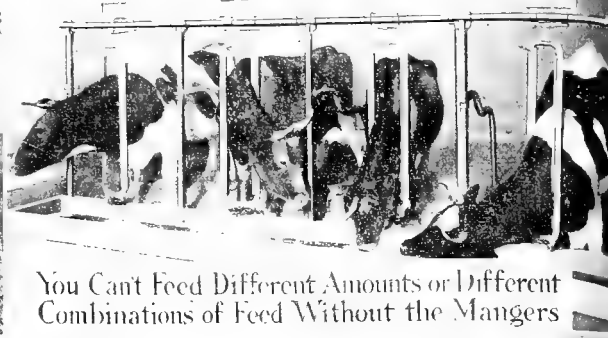
With each shipment sufficient paint is sent to cover all marks or scratches received in shipment.

Our experience has shown that the electro galvanizing is not satisfactory; and the hot process of galvanizing, on account of the heat required, makes the malleable iron parts brittle. The surface also is not smooth and is less easily kept clean. We, therefore, recommend the enamel, baked on.

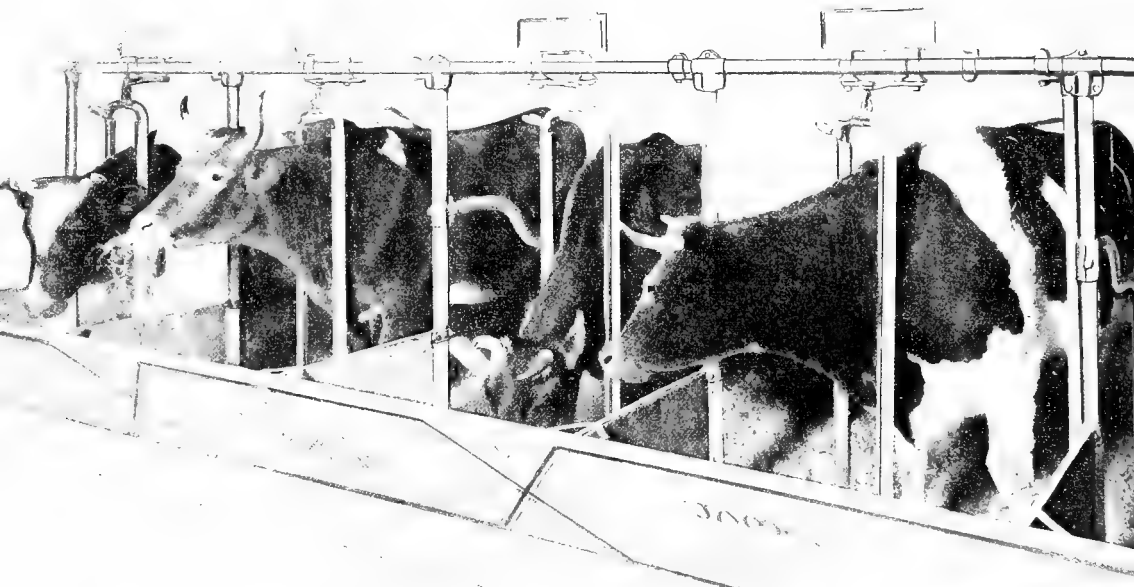
Mangers and carrier tubs are always furnished galvanized.



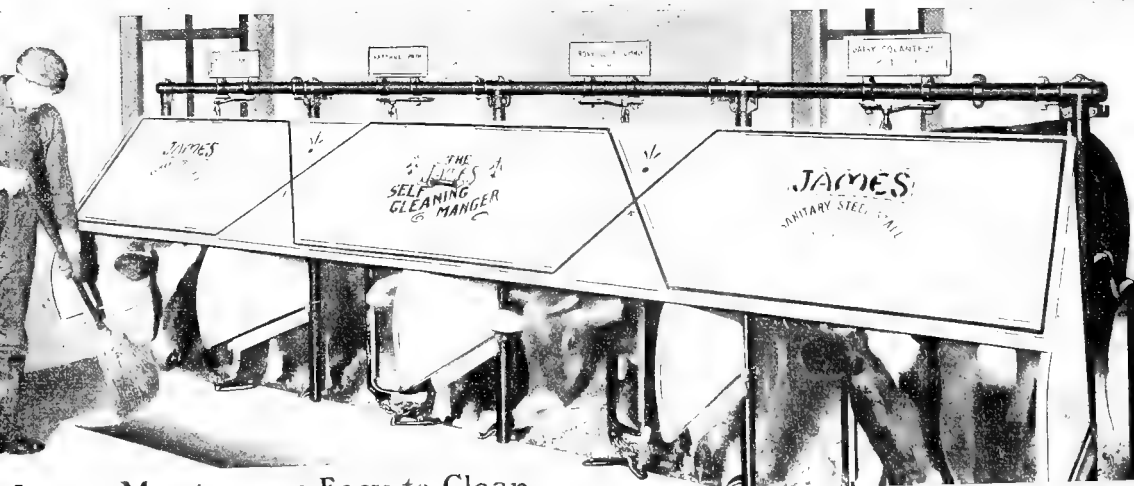
The Fast Eater Robs Her Neighbor Without Individual Mangers



You Can't Feed Different Amounts or Different Combinations of Feed Without the Mangers



No Cow Can Steal from Another if James Mangers are used



James Mangers are Easy to Clean

## The James Complete Manger

(PATENTED)

Not only does the James Complete Manger enable you to feed each cow individually, preventing underfeeding and overfeeding and troubles incident thereto; but it also does away with the labor required in keeping a rigid manger clean; prevents waste of feed; eliminates the principal cause of big knees; and prevents abortion and other injuries brought on when straining for feed thrown out of the cow's reach or belonging to her neighbor.

Successful dairymen seem to agree that, to get the best results, each cow must be fed separately.

Scarcely any two cows in a herd require the same amount of feed; and it is just as bad for a cow to get too much as too little.

A cow that gets too much feed may be put out of the profit class for a month.

You can't feed your cows individually on a level floor or in the continuous trough. The cow that eats fastest gets too much and the slow eater next to her gets too little.

Neither produces what she would if fed individually and the heavy eater is likely to be ruined.

Besides overfeeding or underfeeding your cows to their injury and your loss, you waste feed by such a method.

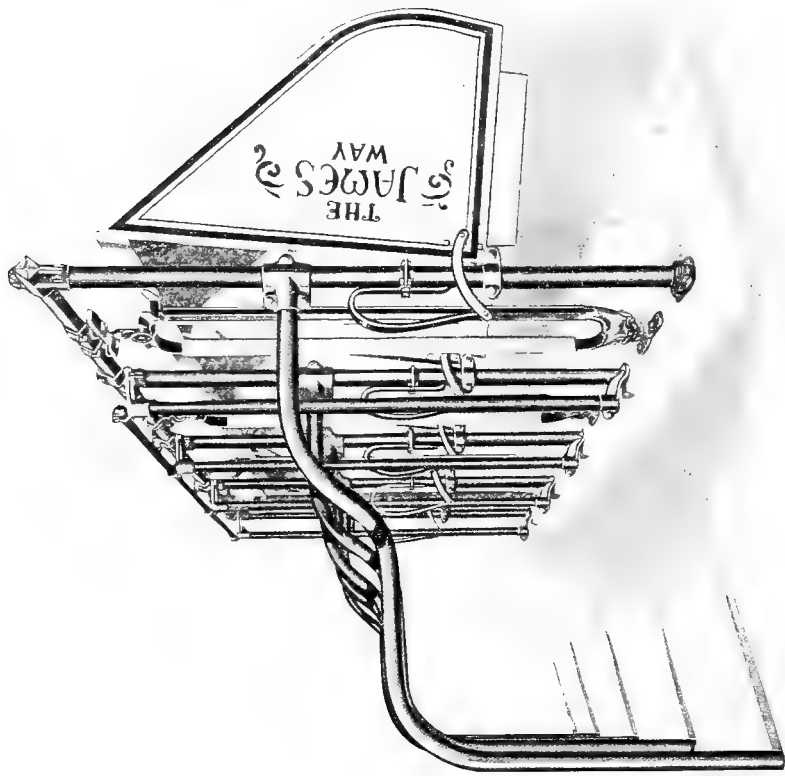
The necessity for individual mangers in order to feed correctly was demonstrated forcefully at the National Dairy Shows. In the feeding test department, the exhibitors using stalls without mangers were required to put in temporary individual mangers. Otherwise they could not meet the conditions of the competition; thus proving conclusively that some kind of a manger division is necessary.

Without a manger division, it is impossible to feed scientifically, giving each cow the particular combination of feeds, as well as the particular amount, on which she will best thrive and produce the greatest yield.

### Big Knees on Dairy Cows

The principal cause, almost the sole cause, of big knees on dairy cows, is the method of feeding in flat bottomed mangers or without any manger at all.

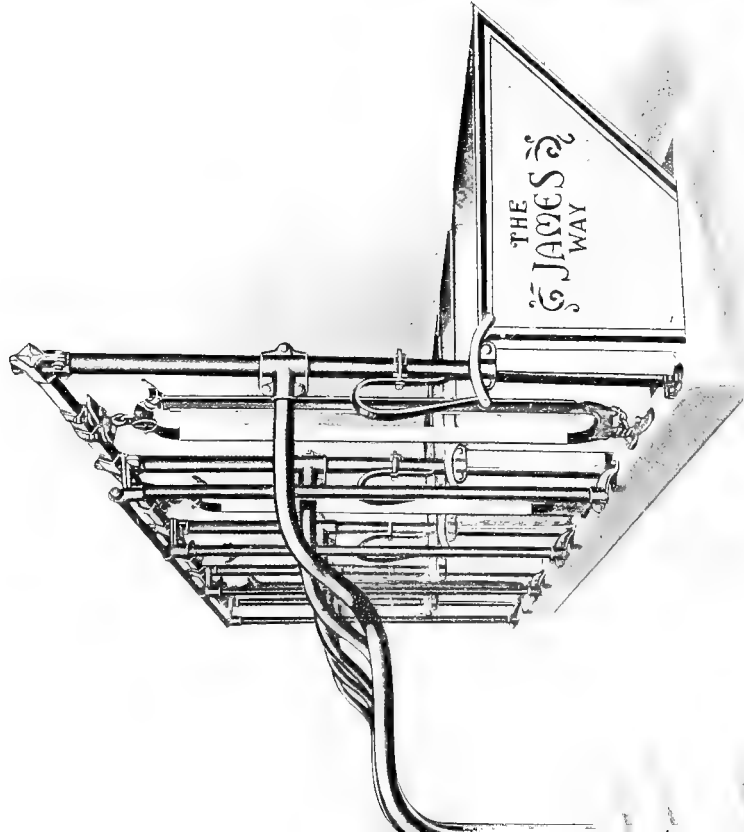
If you feed that way, watch your cows. To get all their feed they are obliged to go to their knees to reach it. The knees strike the curb or floor, and, standing in this position for a considerable time during each feeding, the cow develops big or sore knees.



Manger lifting springs are so designed as to prevent cow from raising manger with her horns.

(PATENTED

The springs hold the manger up in position when manger is raised.



## How Abortion is Sometimes Caused

Not only are big knees caused in this manner, but in pushing herself forward, striving to reach the feed, the cow's hind feet slip and push her bedding into the gutter.

A sudden slipping of the hind feet, or straining for feed beyond her reach, sometimes causes abortion or perhaps permanent injury to the cow.

## The Self-Cleaning Feature

The James Manger has no bottom, a concave trough in the cement floor serving that purpose. The manger is easily lifted, the weight being offset by heavy manger lifting springs.

When the manger is lifted, everything in the trough can be conveniently and quickly swept out, flushed with water if desired and used as a watering trough.

The bottom of the trough is so shaped that the feed comes in exactly the right spot for the cow to reach it most easily, even to the last mouthful—the feed always accumulates in the center of the trough directly under the cow's nose.

## The Manger Construction

The manger is constructed of No. 20 gauge best galvanized sheets.

The front of the manger, in sections of three stalls or less, is formed from 20 gauge copper bearing galvanized sheets, both the front and the partitions being strongly reinforced with folded and compressed edges. The front of the manger is bolted to the partitions.

The U-shaped guard which is riveted to the back of the manger partition, overlaps the stall post and holds the partition firmly and rigidly at the back; while manger front and partitions are reinforced by V-braces, except at ends.

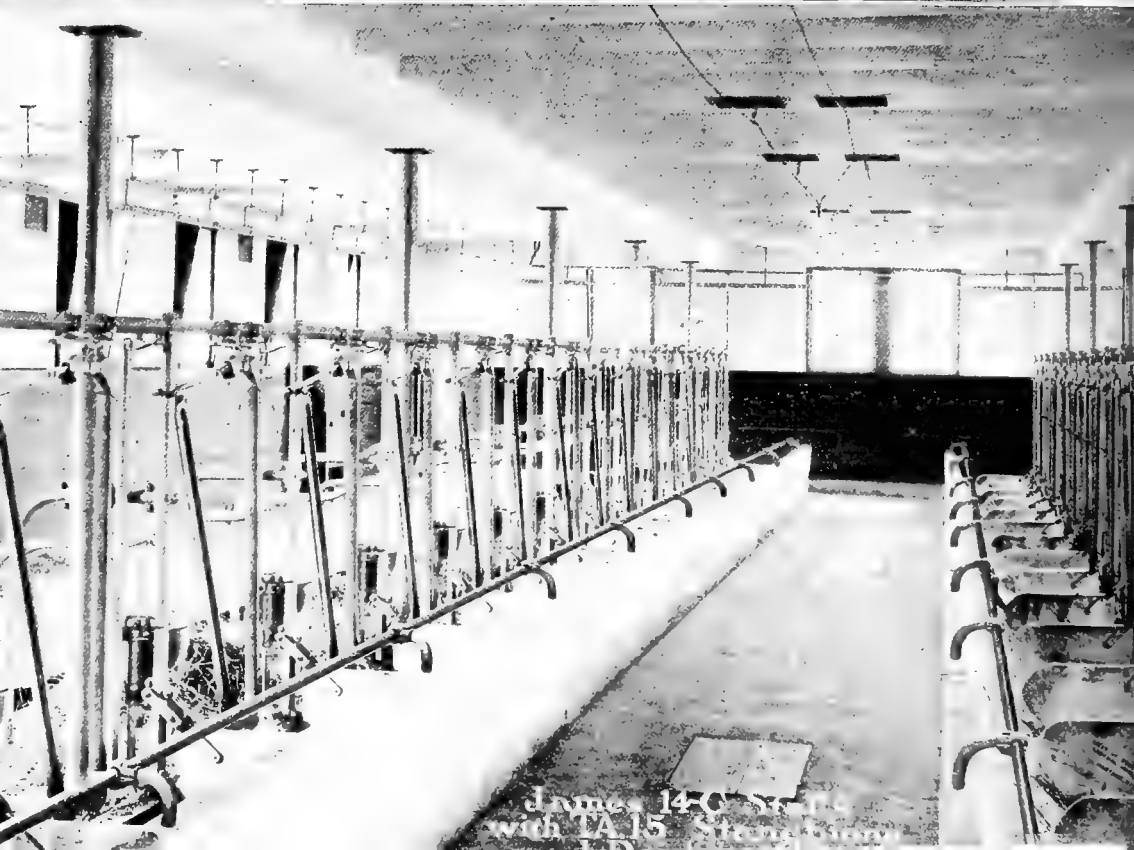
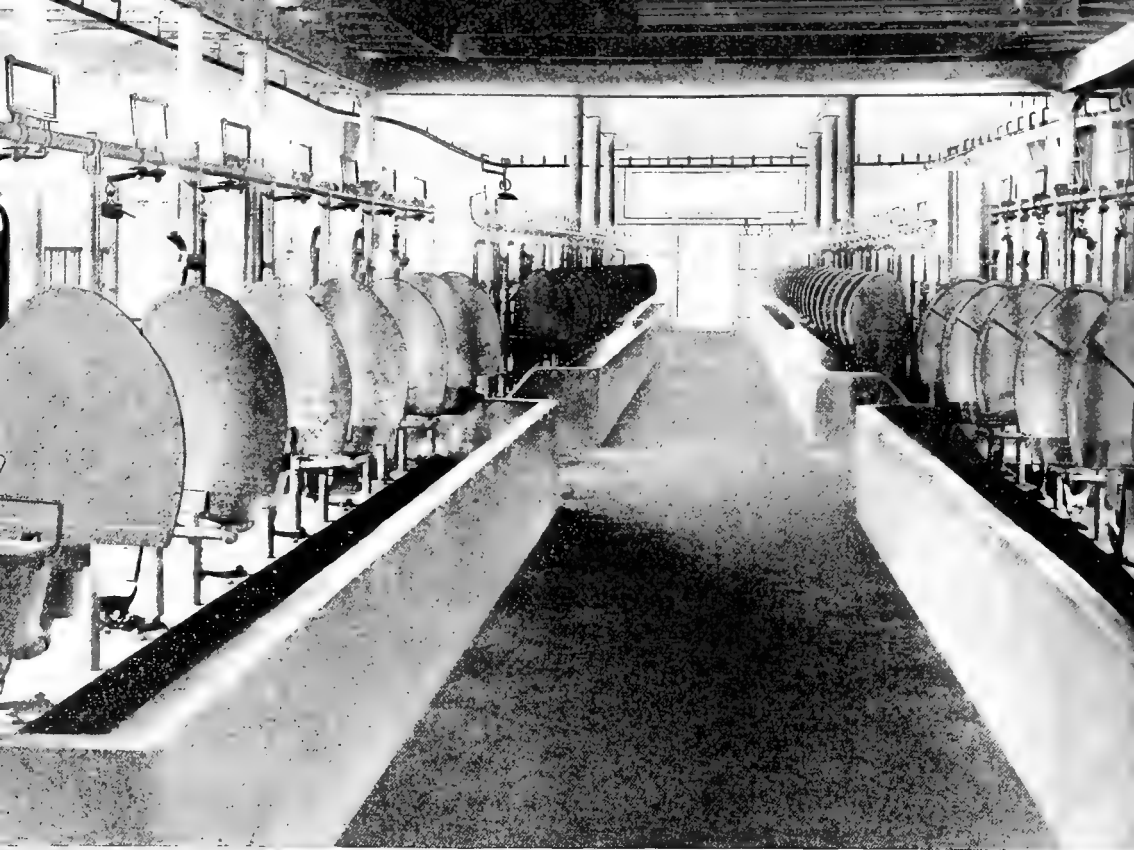
This rigid construction of the James Manger absolutely prevents any racking and adds years to the life of the manger.

The U-guard also permits setting the stall posts in the center of the concrete curb, so that the curb is not liable to crack—as it is when the posts are set near the edge of the curb.

With all its labor, feed and money saving advantages the James Manger costs no more than a home made one of wood.

Whether you order mangers or not, be sure to obtain from us the wood pattern of exact shape of the manger bottom. This will enable you to make the concrete manger trough so that a perfect fit will be secured if you later decide to have the mangers. The manger pattern is absolutely necessary if the mangers are to fit the trough properly.





James 140 Spindle  
with 1A 15 Spindle  
L.D.

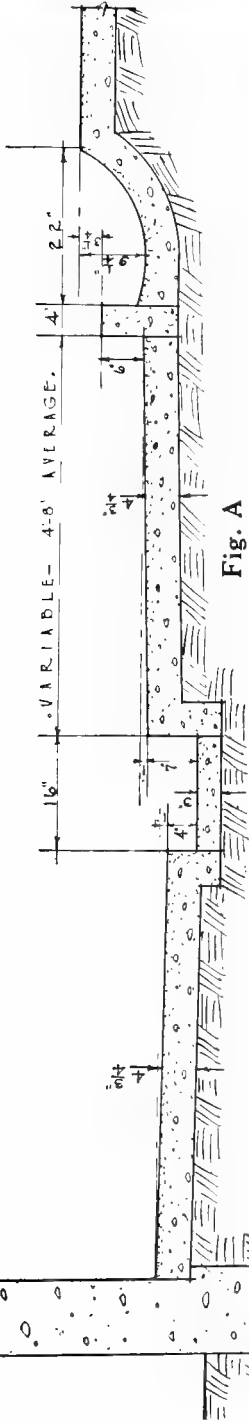


Fig. A

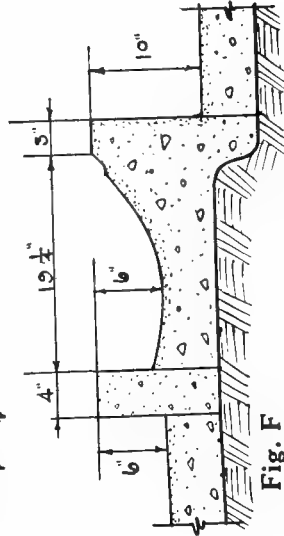


Fig. F

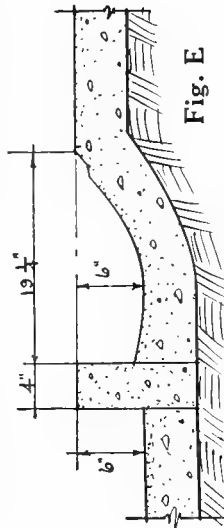
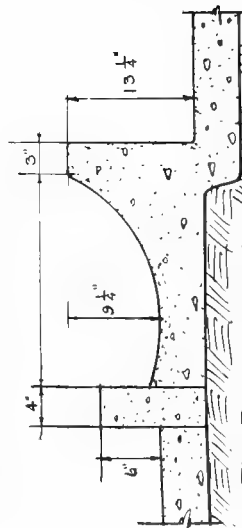


Fig. E



**Types of concrete manger fronts commonly used.**

**Choose the one best suited to your needs.**

Figs. A and F can be built by use of wood pattern for James Complete Manger; Figs. E, B, D and C can be built by use of wood pattern for James Manger Division.

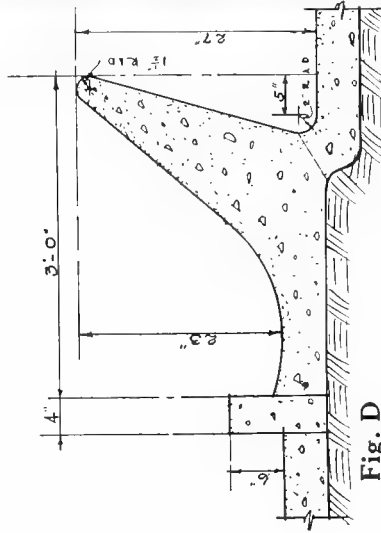


Fig. D

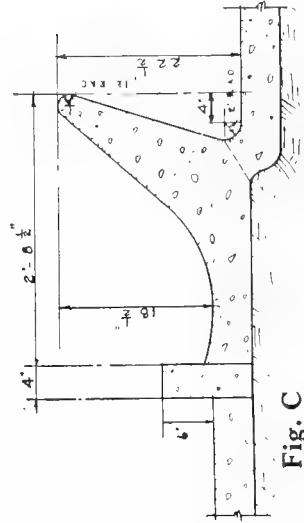
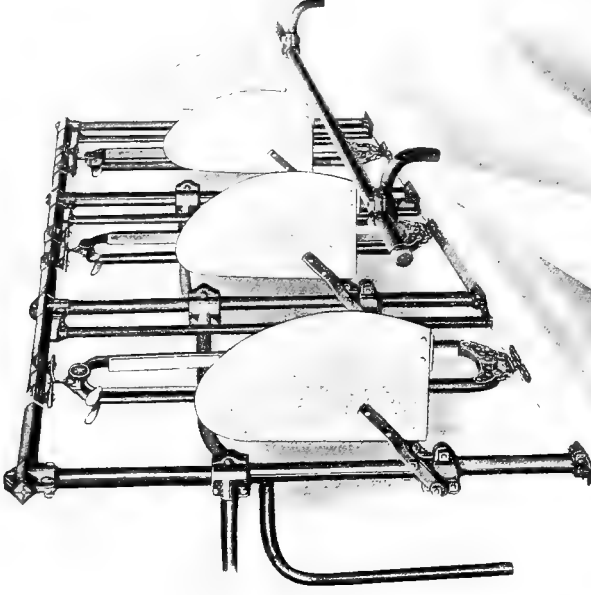
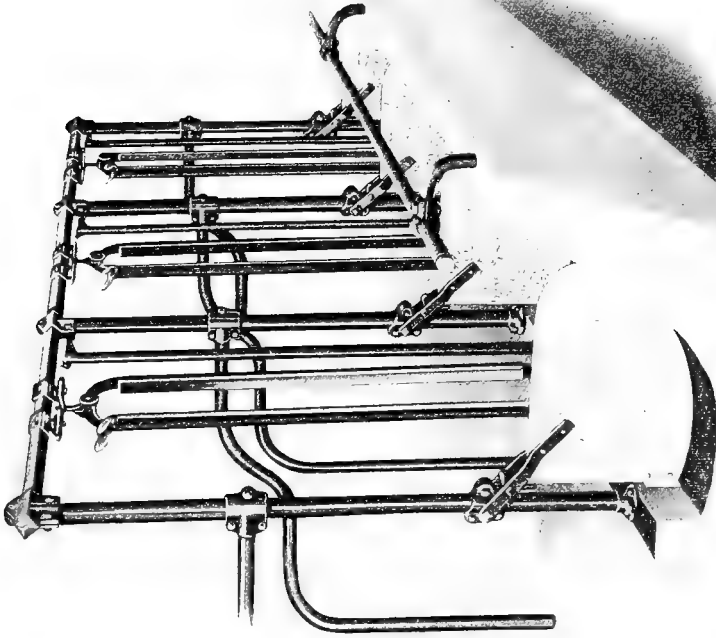


Fig. C



**James Manger Divisions**

**An ingenious latch holds division up when raised**  
PATENT APPLIED FOR.

## Manger Lifting Springs

The Manger Lifting Springs are so adjusted that when the manger is down, the tension of the springs and the weight of the manger prevent the cow from lifting it.

But when the manger is raised a few inches, past a certain point, the pull of the spring offsets the weight of the manger, making it easy to lift; and then holds the manger up in position.

The springs reduce the strain on the manger, for each spring pulling evenly on the manger partition does away with racking when manger is raised, thus adding to the manger's life.

The springs are of special design of cold drawn, flat spring steel, oil tempered and tested for severe use—the same as the best automobile springs. The tension is easily adjusted, should adjustment ever be needed.

It is sanitary, and presents a neat appearance in the barn.

Regularly furnished, four Manger Lifting Springs to each five stalls.

## James Manger Divisions

(PATENT APPLIED FOR)

In various barns already built, which we have been called upon to equip, we have found concrete mangers of such design that the James Complete Manger could not be used.

To meet this condition and make it possible for every dairyman to have individual manger compartments for feeding, we have designed the James Individual Manger Divisions.

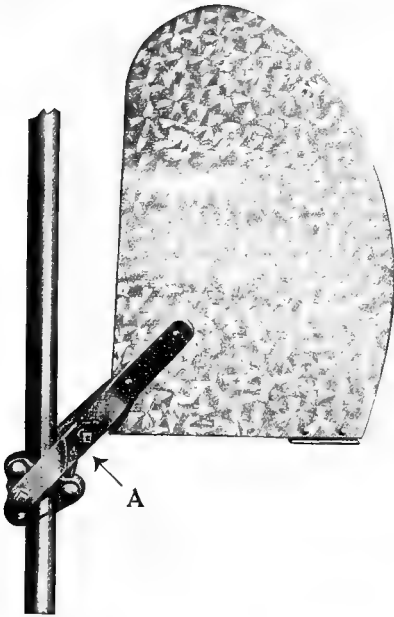
These manger divisions as regularly furnished are fourteen inches high; which is sufficiently high to prevent a cow from stealing feed from her neighbor.

Divisions are made of eleven gauge galvanized sheet steel, 14 in. high and  $21\frac{5}{16}$  in. wide. The strong, heavy, malleable hinge will not slip and holds the division firmly in position.

When raised the division is held in place by an ingenious holder. See cuts A, B and C, page 142.

The cuts on the opposite page illustrate the manger divisions. The manger curb can be built as desired; some of the more common styles of curb are shown on page 139.

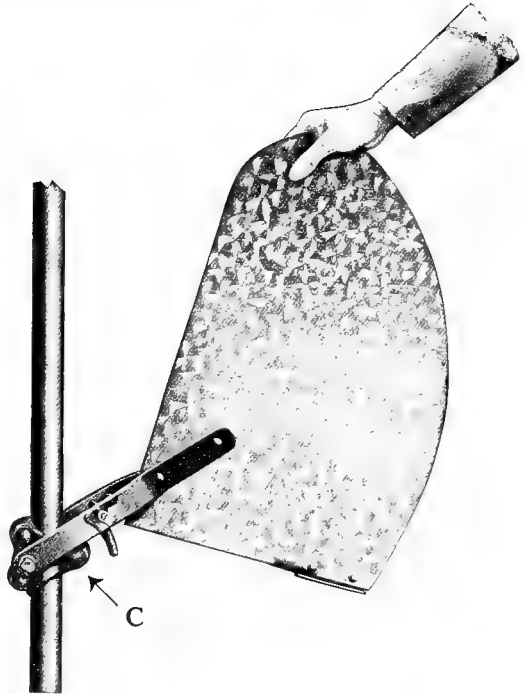
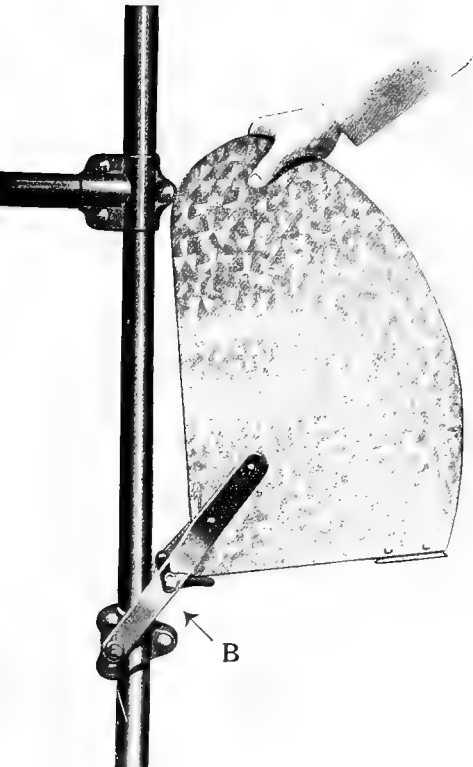
Manger Pattern must be used in making manger trough, if Manger Divisions are to fit properly. Manger pattern is furnished free.



### Manger Division Holder

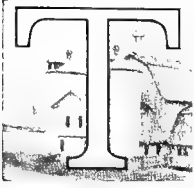
This ingenious device (shown in "phantom" in cuts A, B and C) adds greatly to convenience of lifting and lowering the manger divisions.

To lock in raised position "A" lift the division to "B", then let it *drop of its own weight*. The holder will catch on the clamp (as in cut "A"), holding the manger division up.



To lower manger division: From "A" raise to position "B", then a quick push downward will carry the holder past the clamp before the holder can catch. (See cut "C".)

# James Stalls and Stanchions



THE James line of stalls and stanchions gives such a wide range of choice, both as to equipment of the stall itself and price, that any farmer can find a stall that just meets his needs. In reality, there is just one James stall—there is but one standard of James quality—one way of finishing James goods—one system of inspection to make sure every detail is right.

No matter whether you buy James stalls with or without special features, you get the same class of stall; price differences are regulated entirely by addition or subtraction of special features—not by quality, or finish or inspection.

James quality is always standard, whatever combination you may buy. Your barn, equipped with James Grand Prize stalls, with or without the special features, will be a good barn.

Do not think that you must have all of the James special features in order to enjoy barn efficiency. The James stall is a unit stall; not only can James stalls be purchased in lots of any size from one up, and one or more stalls added at any time; but you can if you desire begin with the James foundation stall, and add any James special features later as you may want them.

You can equip your barn, step by step, not only as your herd grows, but you can add the special features, one by one, as you decide you need them.

James stalls are found in hundreds of the finest dairy barns in the United States; and they are also serving thousands of dairymen who are doing business on a smaller scale. The small barn that is equipped with James 18F or 18E stall is a James barn, through and through, and many dairymen who started with stalls without all the special features are adding James special features right along, because the equipment is making increased barn profits each year.

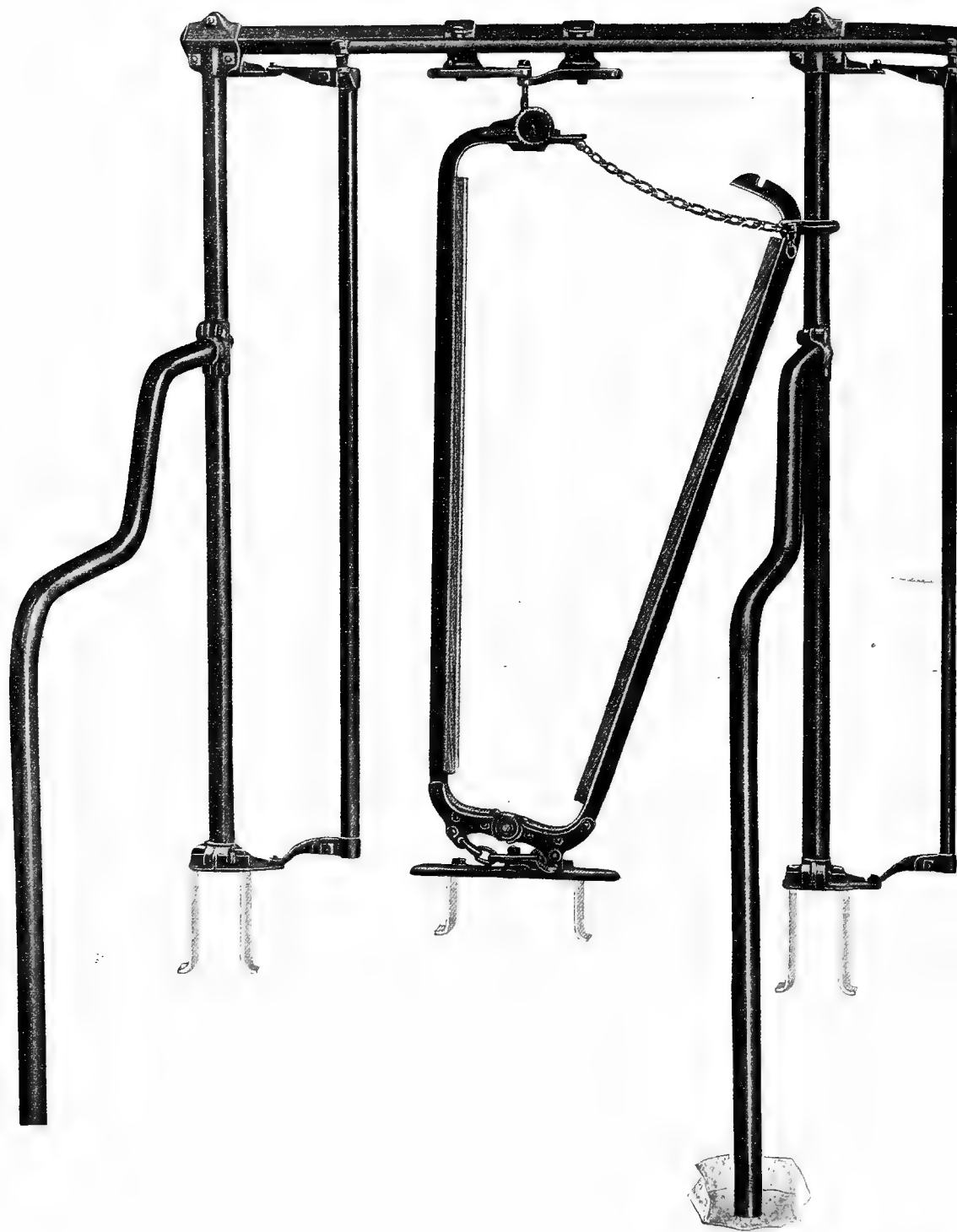
Each stall combination in the James line offers the greatest possible value to be found anywhere at the price.

The James stall No. 14B is the foundation of all James stall combinations; all the others being based on the 14B, simply adding or subtracting certain labor, feed and money-saving devices, or substituting a different stanchion.

Consider for a moment this foundation stall—the No. 14B which costs hardly more than a home-made wood stall.

The stall uprights are built of heavy selected pipe,  $1\frac{5}{8}$ -inch O. D., thickness of pipe wall about .14 inch, rolled especially for this purpose. The horizontal of the stall frame is of heavy pipe,  $1\frac{1}{2}$  inches square, thickness of pipe wall about .13 inch.

The triple curve stall partition is made of the best quality of pipe, especially designed for the purpose,  $1\frac{5}{8}$ -inch outside diameter, thickness of wall about





.14 inch, accurately bent by our heavy special machinery.

This partition not only braces the stanchion frame, doing away with supporting the stalls by ceiling posts, but it also protects the cow and the milker, saving many a cow from a damaged udder.

The stall upright, the horizontal part of the frame, and the stall partitions, are bound firmly together by heavy malleable fittings, into a substantial, durable frame. The fittings are readily drawn together by cut thread bolts to the exact shape of the pipe, and when bolts are properly tightened, have a vice-like grip. Fittings are of sanitary type, edges overlapping, lessening dust accumulation.

Most dairymen realize that a sure-stop of some kind is required at the time cow is entering the stall; but to afford maximum comfort, this sure-stop must be out of the cow's way, after being locked in the stanchion. She needs plenty of head room to card herself on either side and to lie down naturally.

The swinging sure-stop is the only sure-stop that is in place when the cow is entering the stall, yet out of the way when locked in her stanchion.

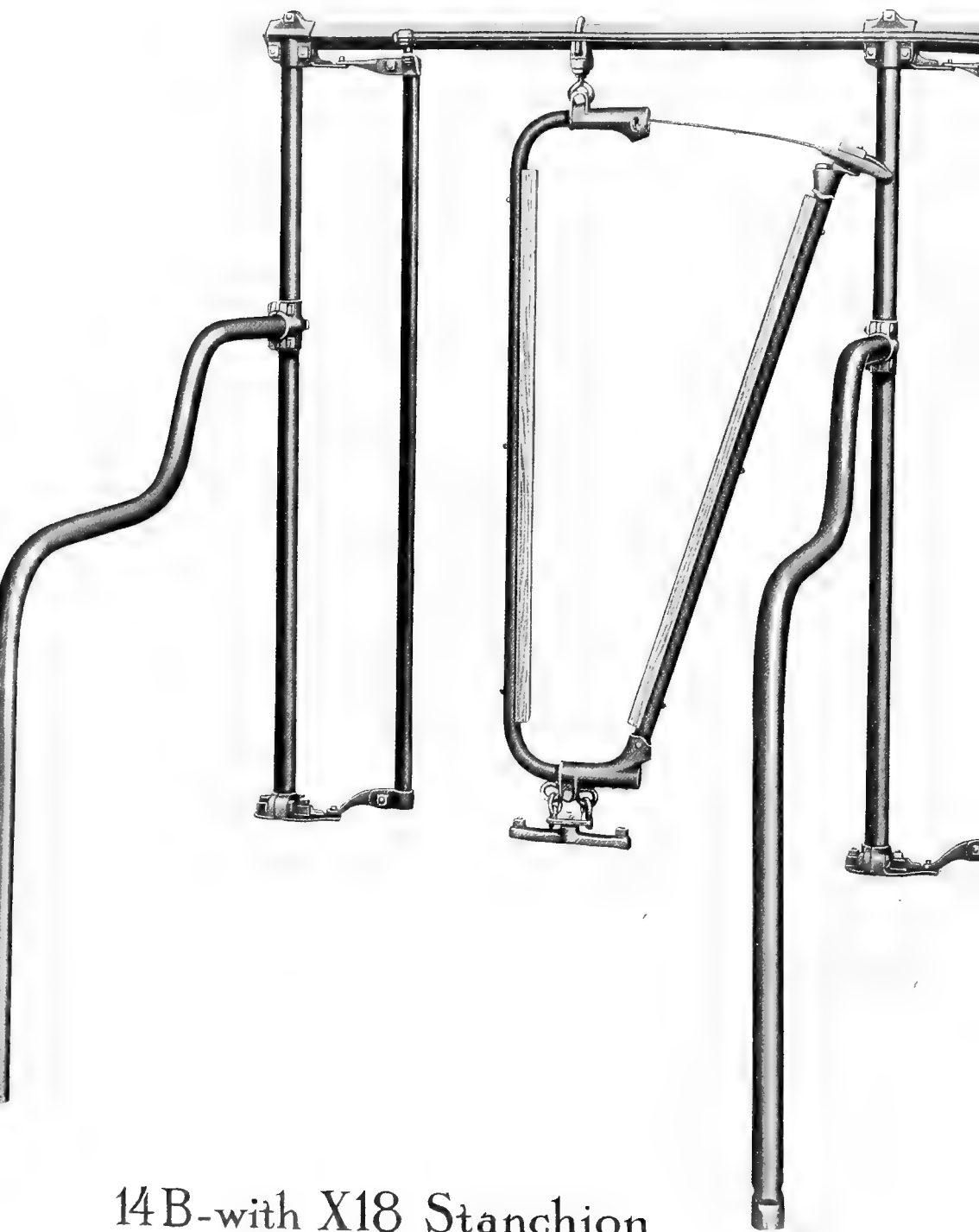
Many a dairy farmer has told us that the James alignment device is worth more than the price of the entire stanchion, and the most valuable feature of the stall. This device enables you to lengthen or shorten the stall to fit the length of the cow, so that all cows are lined up at the rear on the gutter; the manure falls in the gutter, keeping the stall and the cow clean.

Stall 14B has the J14 stanchion—James cow-proof door knob lock; lock-open clip; wood lining; heavy hinge of unusual strength; double chain hangers with flat steel links; James alignment device; and the James stanchion anchor which prevents trouble through rusting of bolts imbedded in concrete.

It is no small task to properly erect stalls, the upright posts of which must be imbedded in the concrete curb. We have made such stalls for many years, and experience has demonstrated that it requires a mechanic to do a satisfactory job, because when the stall posts are set in place it is necessary to brace them from the ceiling and in the curb and keep them so braced until the concrete has hardened. The addition of the stall post anchors cuts the time and the expense of installation to the minimum, makes the erection of the stall so easy a boy can do the work, and assures a perfect job in every case.

We find that on the average job, the James system of anchors reduces the cost of installation from 35c to 50c per stall, and contractors who make a business of erecting barn equipment, will, if they have had experience, make a far lower price on the erection where James stalls and stall anchors are used.

This stall, and all other James stalls, are finished in the battleship gray color. Every piece of metal is mechanically cleaned, all scale, grease and foreign matter being thoroughly removed, thus properly preparing it for painting. Then finished with best gray protective enamel made for us under our own formula, thoroughly baked for two hours at a high temperature.



14 B.-with X18 Stanchion

The stall is shipped with all fittings assembled on the frame, saving a great deal of time and trouble in erecting. The fittings being assembled before painting, the entire equipment is painted, including bolts and fittings.

All this is what you get in the 14B stall.

Other combinations can be made up by the addition of the manger divisions to stall 14B, as in stall 14C, or by adding the complete mangers as in stall 14A; and by the addition of the drinking cups; or the name plate holders; or by the substitution of stanchion TA15, T15, X18 or XA18.

Or, if you wish a stall lower in price than the 14B, stall 18E is the No. 14B with a rigid sure-stop, and with X18 stanchion.

Stall 18F is still lower in price, being the 14B stall without anchors, without sure-stop, and with X18 stanchion in place of the J14.

You will quickly see by a study of the following pages and by what we have said above, that from the James line you can make up a combination of special features that will give you anything that you may need in the way of service, or to fit your desires as to price.

Whatever the combination you buy in a James stall, the equipment will reach you already assembled, each fitting bolted firmly on the pipe. There will be no boxes of small parts, no lists of little pieces to check, nothing complicated. One man can erect it easily. You cannot go wrong.

### Regarding Specifications

Pictures sometimes may be misleading. The picture of a light harness and the picture of a heavy harness might be made to look alike.

Photographs of a poorly-built buggy and of a buggy of the finest and most durable material and best workmanship might show no difference.

So with pictures of stalls and carriers and other equipment. The pictures give but little information as to the material, workmanship and finish.

If there be any doubt whatsoever in your mind as to the superiority of James goods, compare for yourself, if at all possible, James equipment with that other which you may consider buying.

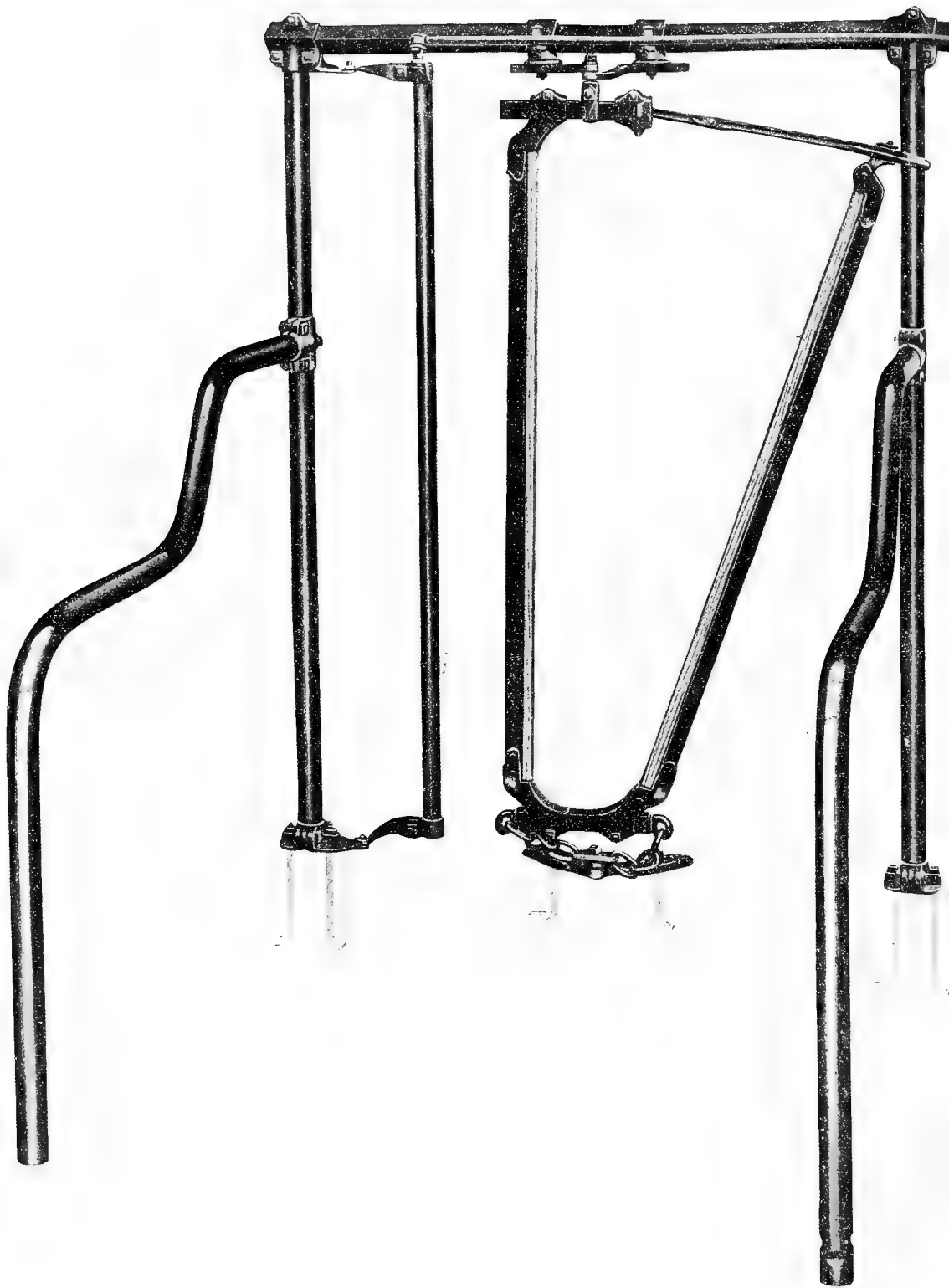
If it be not possible to compare actual goods, the best substitute is a careful comparison of specifications. To enable you to do this, we give accurate detailed specifications in this book of all items in the James line.

**Note especially weights of stalls, carriers, pens and other equipment. James Equipment is heavy.**

Although weight is not always a true index to strength (because there may be too great weight where strength is not needed and too little weight where strength is needed), nevertheless if two competing articles be equally well designed, the greater weight does indicate the greater strength.

In these days of high-priced steel and iron, it would be very easy for us to save a large amount on the cost of a stall or stanchion, simply by reducing the amount of material used; this might be done and no one the wiser, but there has been no skimping of material in the manufacture of any of the James equipment. James standards of manufacture and inspection are maintained.

There are so many combinations that may be made in James stalls, that no attempt is made to show them all, but merely those most in demand.



14 B with TA 15 Stanchion

## James Stall 14B-TA15

(PATENTED)

## SPECIFICATIONS

- UPRIGHTS and HORIZONTALS: Upright stall posts are of pipe  $1\frac{5}{8}$ -inch outside diameter, thickness of pipe wall about .14 inch; horizontal is of the same material  $1\frac{1}{2} \times 1\frac{1}{2}$  inch square, thickness of wall about .13 inch. Patent applied for.
- FITTINGS: Best malleable. Size and strength sufficient to withstand all strain. Dust-proof type. (See page 114.)
- PARTITIONS: The James triple curve stall partitions as described on page 115 made of pipe  $1\frac{5}{8}$  inch O. D., thickness of pipe wall about .14 inch.
- SURE-STOP: The swinging sure-stop consists of a post of  $1\frac{5}{16}$ -inch O.D. pipe with the opening at the top closed with dust-proof ornament; dust-proof hinge fittings are of best malleable; the rod connecting the row of sure-stops is  $\frac{1}{2}$ -inch pipe, openings at ends closed with dust-proof ornaments. (See page 103.)
- ANCHORS: Heavy galvanized steel 2 inches wide; one furnished for each stanchion and each stall upright post. Anchors have templates attached to make accurate setting of anchors easy. Anchors are the only part of the stall required at the time concrete is laid; the stall is easily attached to the anchors at any time later. Patented. (See page 122.)
- STANCHION: James stanchion TA15 described on page 165. Patented. Alignment device; double chain hanger; side bars of carbon steel  $1\frac{1}{4} \times 1\frac{1}{4} \times \frac{3}{16}$ -inch; lined with thoroughly seasoned birch securely attached; lock open device; cow-proof lock.
- FINISH: The steel is first mechanically cleaned removing scale, grease and foreign matter, thoroughly preparing the material for painting; it is then finished with the best grade protective enamel, baked for two hours at a high temperature. (See page 129.)
- MANGER PATTERN: Will be furnished free or on request; made of hardwood exact shape of manger partition bottom, that manger trough in the concrete may be so shaped that the James complete manger or the manger division, depending on pattern used, will fit accurately if you later wish to add the mangers to the stalls. See page 124. Be sure to specify the style of manger pattern wanted — pattern No. 1 for the complete manger and pattern No. 4 for the manger division. Pattern No. 4 will be sent with all steel stall orders unless No. 1 is specified.
- WIDTH OF STALL: We carry in stock 3 feet 2 inches, 3 feet 4 inches and 3 feet 6 inches. 3 feet 6 inches width will be furnished if not otherwise specified.
- WEIGHT: About 85 pounds per stall.

Shipped assembled, knocked down for convenience in handling and ease of erection. (Page 127.)

## James Stall 14B-X18

(PATENTED)

Page 146.

Same specifications as above, except:

- STANCHION: James stanchion X18 (Page 167). Patent applied for. Side bars made from  $1\frac{5}{16}$ -inch O. D. steel pipe, lined with thoroughly seasoned birch; lock open clip; cow-proof lock; chain hanger.

## James Stall 14B

(PATENTED)

Same specifications as 14B-TA15, except:

- STANCHION: James stanchion 14J described on page 163. Door knob type of cow-proof lock; James alignment device; lock open clip; James double chain hanger; James anchors; side bars of carbon steel tees  $1\frac{1}{4} \times 1\frac{1}{4} \times \frac{3}{16}$ -inch lined with thoroughly seasoned birch securely attached.



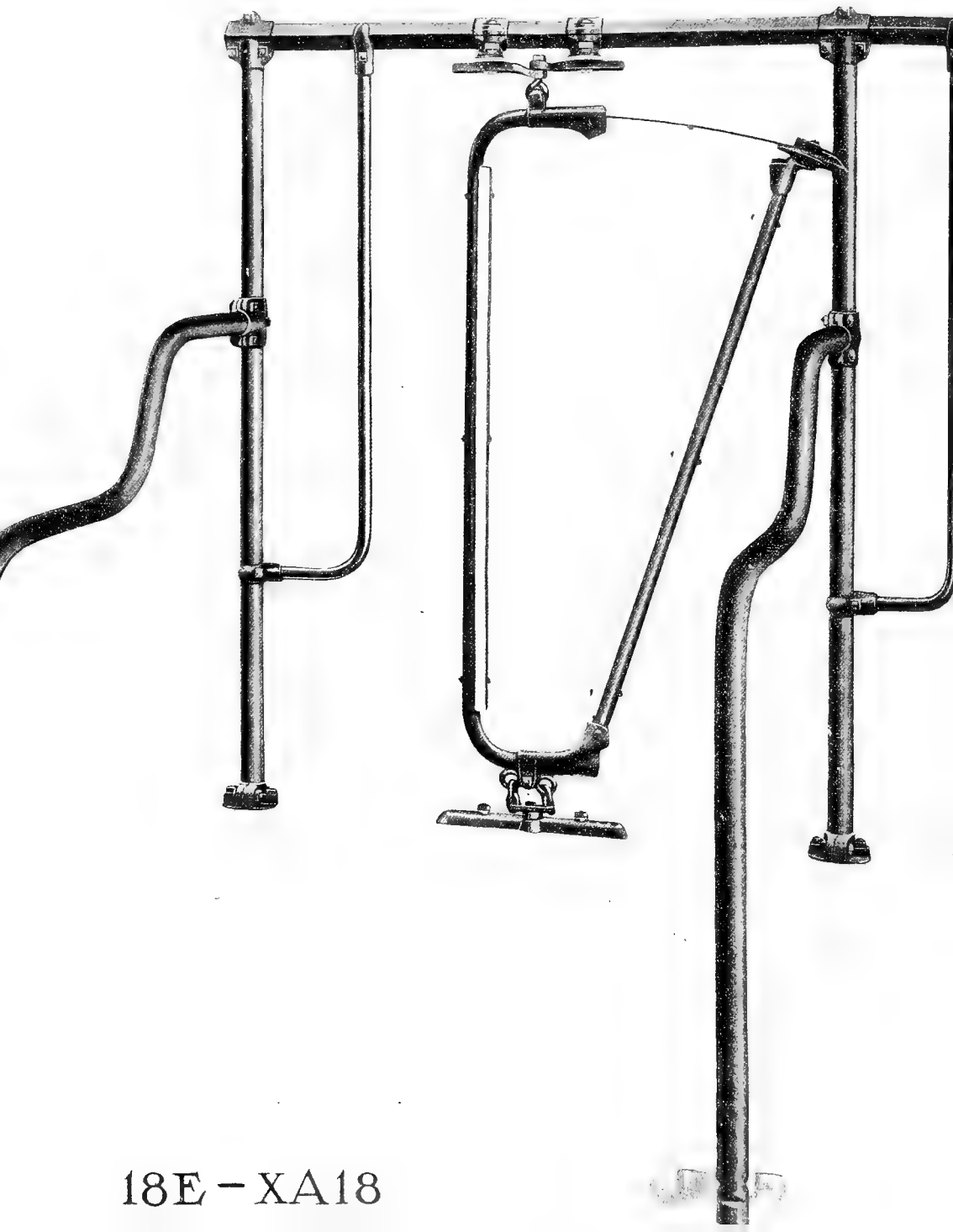
## James Stall 18-F

PATENTED

### SPECIFICATIONS

- UPRIGHTS and HORIZONTALS:** Upright stall posts are of pipe  $1\frac{5}{8}$ -inch outside diameter, thickness of pipe wall about .14 inch; horizontal is of the same material  $1\frac{1}{2}$  x  $1\frac{1}{2}$ -inch square, thickness of wall about .13 inch. Patent applied for.
- FITTINGS:** Best malleable. Size and strength sufficient to withstand all strain. Dustproof type. (See page 114.)
- PARTITIONS:** The James triple curve stall partitions as described on page 115 made of pipe  $1\frac{5}{8}$ -inch O. D., thickness of pipe wall about .14 inch.
- ANCHORS:** Heavy galvanized steel 2 inches wide; one furnished for each stanchion. Anchors have templates attached to make accurate setting easy. Patented. (See page 122.)
- STANCHION:** James stanchion X18 (page 167). Patent applied for. Side bars made from  $1\frac{5}{8}$ -inch O. D. steel pipe, lined with thoroughly seasoned birch; lock open clip; cow-proof lock; chain hanger.
- FINISH:** The steel is first mechanically cleaned removing scale, grease and foreign matter, thoroughly preparing the material for painting; it is then finished with the best grade protective enamel, baked for two hours at a high temperature. (See page 129.)
- MANGER PATTERN:** Will be furnished free or on request; made of hardwood exact shape of manger partition bottom, that manger trough in the concrete may be so shaped that the James complete manger or the manger division, depending on pattern used, will fit accurately if you later wish to add the mangers to the stalls. See page 124. Be sure to specify the style of manger pattern wanted — pattern No. 1 for the complete manger and pattern No. 4 for the manger division. Pattern No. 4 will be sent with all steel stall orders unless No. 1 is specified.
- WIDTH OF STALL:** We carry in stock 3 feet 2 inches, 3 feet 4 inches and 3 feet 6 inches. 3 feet 6 inches width will be furnished if not otherwise specified.
- WEIGHT:** About 63 pounds per stall.

Shipped assembled, knocked down for convenience in handling and ease of erection. (Page 127.)



18E - XA18



**James Stall 18E-XA18**

(PATENTED)

**SPECIFICATIONS**

**UPRIGHTS and HORIZONTALS:** Upright stall posts are of pipe  $1\frac{5}{8}$ -inch outside diameter, thickness of pipe wall about .14 inch; horizontal is of the same material  $1\frac{1}{2}$  x  $1\frac{1}{2}$ -inch square, thickness of wall about .13 inch. Patent applied for.

**FITTINGS:** Best malleable. Size and strength sufficient to withstand all strain. Dustproof type. (See page 114.)

**PARTITIONS:** The James triple curve stall partitions as described on page 115 made of pipe  $1\frac{5}{8}$ -inch O. D., thickness of pipe wall about .14 inch.

**SURE STOP POST:** Rigid type; of  $1\frac{5}{16}$ -inch O. D. pipe and best malleable.

**ANCHORS:** Heavy galvanized steel 2 inches wide; one furnished for each stanchion and each stall upright post. Anchors have templates attached to make accurate setting of anchors easy. Anchors are the only part of the stall required at the time concrete is laid; the stall is easily attached to the anchors at any time later. Patented. (See page 122.)

**STANCHION:** James stanchion XA18. (page 167). Patent applied for. James alignment device side bars made from  $1\frac{5}{8}$ -inch O.D. steel pipe, lined with thoroughly seasoned birch lock open clip; cow-proof lock; chain hanger.

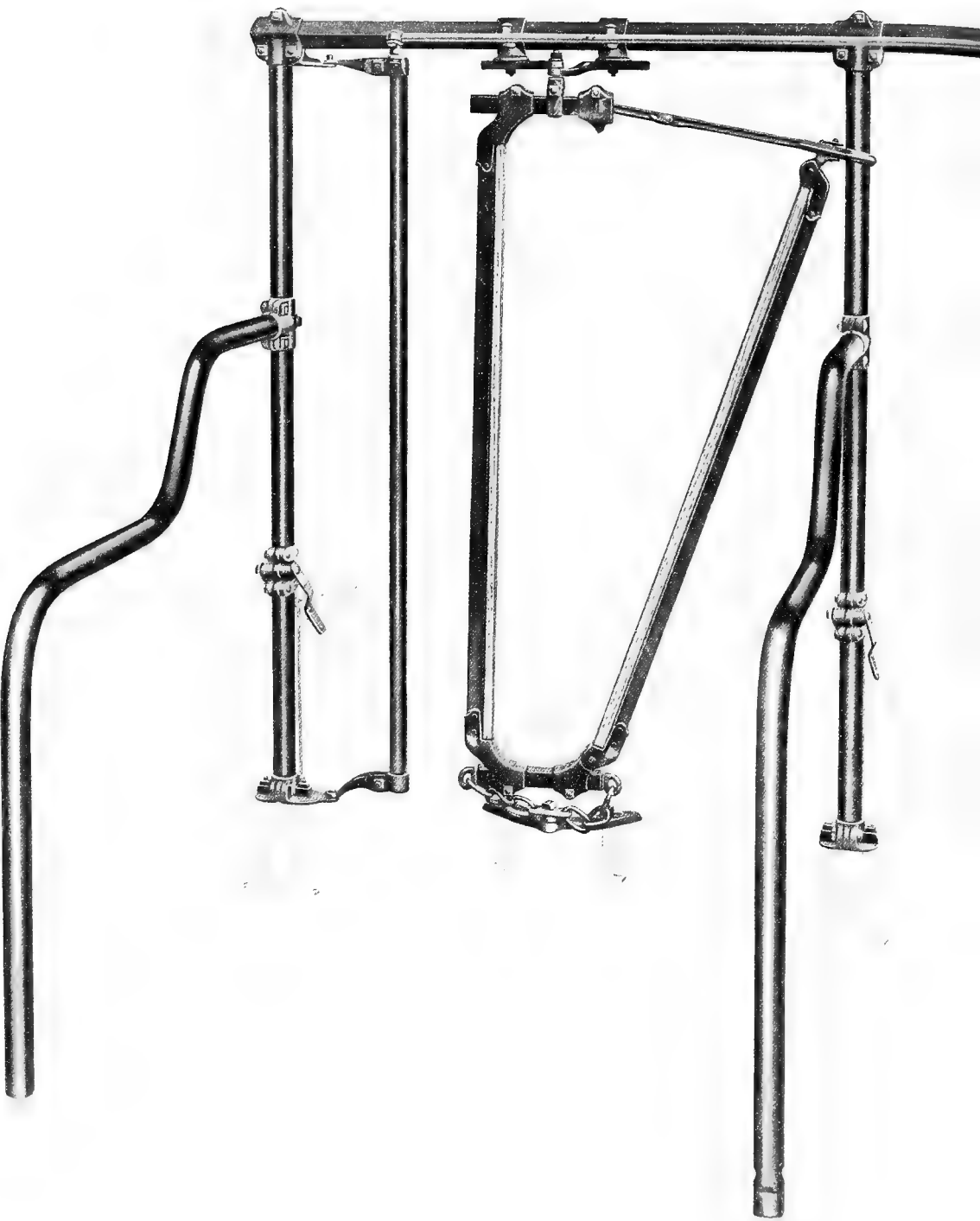
**FINISH:** The steel is first mechanically cleaned removing scale, grease and foreign matter, thoroughly preparing the material for painting; it is then finished with the best grade protective enamel, baked for two hours at a high temperature. (See page 129.)

**MANGER PATTERN:** Will be furnished free or on request; made of hardwood exact shape of manger partition bottom, that manger trough in the concrete may be so shaped that the James complete manger or the manger division, depending on pattern used, will fit accurately if you later wish to add the mangers to the stalls. See page 124. Be sure to specify the style of manger pattern wanted—pattern No. 1 for the complete manger and pattern No. 4 for the manger division. Pattern No. 4 will be sent with all steel stall orders unless No. 1 is specified.

**WIDTH OF STALLS:** We carry in stock 3 feet 2 inches, 3 feet 4 inches and 3 feet 6 inches. 3 feet 6 inches width will be furnished if not otherwise specified.

**WEIGHT:** About 65 pounds per stall.

Shipped assembled, knocked down for convenience in handling and ease of erection. (Page 127.)



14C-TA

## James Stall 14C-TA15

(PATENTED)

## SPECIFICATIONS

- UPRIGHTS and HORIZONTALS:** Upright stall posts are of pipe 1 $\frac{5}{8}$ -inch outside diameter, thickness of pipe wall about .14 inch; horizontal is of the same material 1 $\frac{1}{2}$  x 1 $\frac{1}{2}$ -inch square, thickness of wall about .13 inch. Patent applied for.
- FITTINGS:** Best malleable. Size and strength sufficient to withstand all strain. Dustproof type. (See page 114.)
- PARTITIONS:** The James triple curve stall partitions as described on page 115 made of pipe 1 $\frac{5}{8}$ -inch O. D.; thickness of pipe wall about .14 inch.
- ANCHORS:** Heavy galvanized steel 2 inches wide; one furnished for each stanchion and each stall upright post. Anchors have templates attached to make accurate setting of anchors easy. Anchors are the only part of the stall required at the time concrete is laid; the stall is easily attached to the anchors at any time later. Patented. (See page 122.)
- SURE-STOP:** The swinging sure-stop consists of a post of 1 $\frac{5}{16}$ -inch O. D. pipe with the opening at the top closed with dust-proof ornament; dust-proof hinge fittings are of best malleable; the rod connecting the row of sure-stops is  $\frac{1}{2}$ -inch pipe, openings at ends closed with dust-proof ornaments. (See page 103.)
- STANCHION:** James stanchion TA15 described on page 165. Patented. Alignment device; double chain hanger; side bars of carbon steel 1 $\frac{1}{4}$  x 1 $\frac{1}{4}$  x  $\frac{3}{16}$  inch; lined with thoroughly seasoned birch securely attached; lock open device; cow-proof lock.
- MANGER DIVISIONS:** (Patent applied for). Eleven gauge galvanized sheet steel. A strong heavy malleable hinge that will not slip holds division firmly in position. Regularly furnished 14 inches high. (See page 141.)
- FINISH:** The steel is first mechanically cleaned removing scale, grease and foreign matter, thoroughly preparing the material for painting; it is then finished with the best grade protective enamel, baked for two hours at a high temperature. (See page 129.)
- MANGER PATTERN:** Will be furnished free or on request; made of hardwood exact shape of manger partition bottom, that manger trough in the concrete may be so shaped that the James complete manger or the manger division, depending on pattern used, will fit accurately if you later wish to add the mangers to the stalls. See page 124. Be sure to specify the style of manger pattern wanted—pattern No. 1 for the complete manger and pattern No. 4 for the manger division. Pattern No. 4 will be sent with all steel stall orders unless No. 1 is specified.
- WIDTH OF STALL:** We carry in stock 3 feet 2 inches, 3 feet 4 inches and 3 feet 6 inches. 3 feet 6 inches width will be furnished if not otherwise specified.
- WEIGHT:** About 103 pounds per stall.

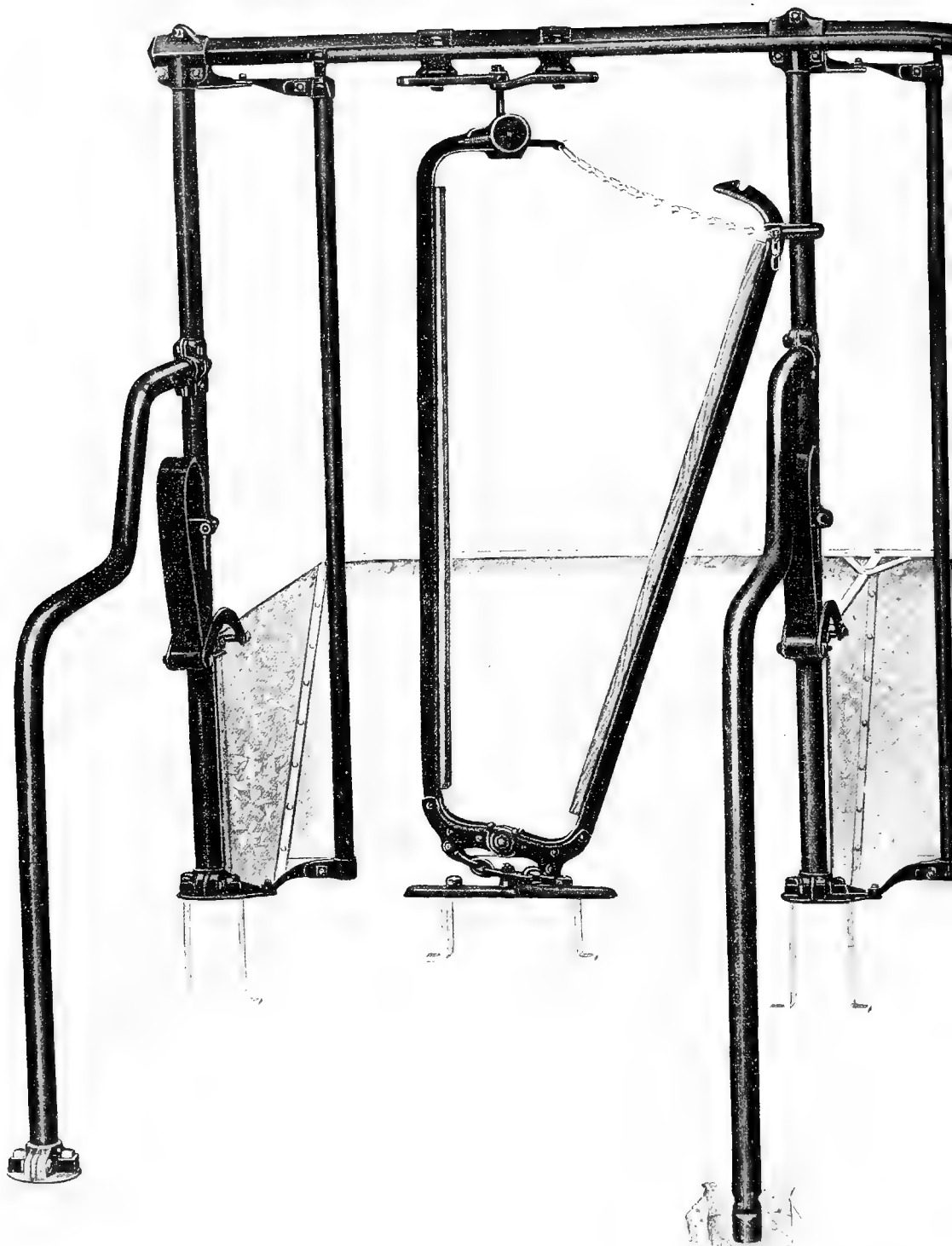
Shipped assembled, knocked down for convenience in handling and ease of erection. (Page 127.)

## James Stall 14C

(PATENTED)

Same specifications as above, except:

- STANCHION:** James stanchion 14J described on page 163. Door knob type of cow-proof lock; James alignment device; lock open clip; James double chain hanger; James anchors; side bars of carbon steel tees 1 $\frac{1}{4}$  x 1 $\frac{1}{4}$ -inch x  $\frac{3}{16}$ -in. lined with thoroughly seasoned birch securely attached.
- WEIGHT:** About 100 pounds per stall.



## James Stall 14A

(PATENTED)

## SPECIFICATIONS

**UPRIGHTS and HORIZONTALS:** Upright stall posts are of pipe  $1\frac{5}{8}$ -inch outside diameter, thickness of pipe wall about .14 inch; horizontal is of the same material  $1\frac{1}{2}$  x  $1\frac{1}{2}$ -inch square, thickness of wall about .13 inch. Patent applied for.

**FITTINGS:** Best malleable. Size and strength sufficient to withstand all strain. Dust-proof type. (See page 114.)

**PARTITIONS:** The James triple curve stall partitions as described on page 115 made of pipe  $1\frac{5}{8}$ -inch O. D., thickness of pipe wall about .14 inch.

**ANCHORS:** Heavy galvanized steel 2 inches wide; one furnished for each stanchion and each stall upright post. Anchors have templates attached to make accurate setting of anchors easy. Anchors are the only part of the stall required at the time concrete is laid; the stall is easily attached to the anchors at any time later. Patented. (See page 122.)

**SURE-STOP:** The swinging sure-stop consists of a post of  $1\frac{5}{16}$ -inch O.D. pipe with the opening at the top closed with dust-proof ornament; dust-proof hinge fittings are of the best malleable; the rod connecting the row of sure-stops is  $\frac{1}{2}$ -inch pipe, openings at ends closed with dust-proof ornaments. (See page 103.)

**STANCHION:** James stanchion 14J described on page 163. Door knob type of cow-proof lock; James alignment device; lock open clip; James double chain hanger; James anchors; side bars of carbon steel tees  $1\frac{1}{4}$  x  $1\frac{1}{4}$  x  $\frac{3}{16}$ -in. lined with thoroughly seasoned birch securely attached.

**COMPLETE MANGER:** Patented. The James individual self-cleaning type. Of heavy gauge best galvanized sheet steel; manger front and partition strongly reinforced by folded and compressed edges. U-shaped guards on partitions overlap the stall posts, and a V-shaped brace joins manger front and partitions, insuring rigidity and preventing racking. Bottom of partitions rounded. (See page 135.)

**MANGER LIFTING SPRING:** Patented. Special design of cold-drawn flat spring; oil-tempered and tested for severe use; same quality as the best automobile spring. Tension easily adjusted. Furnished four springs with five stalls. (See page 141.)

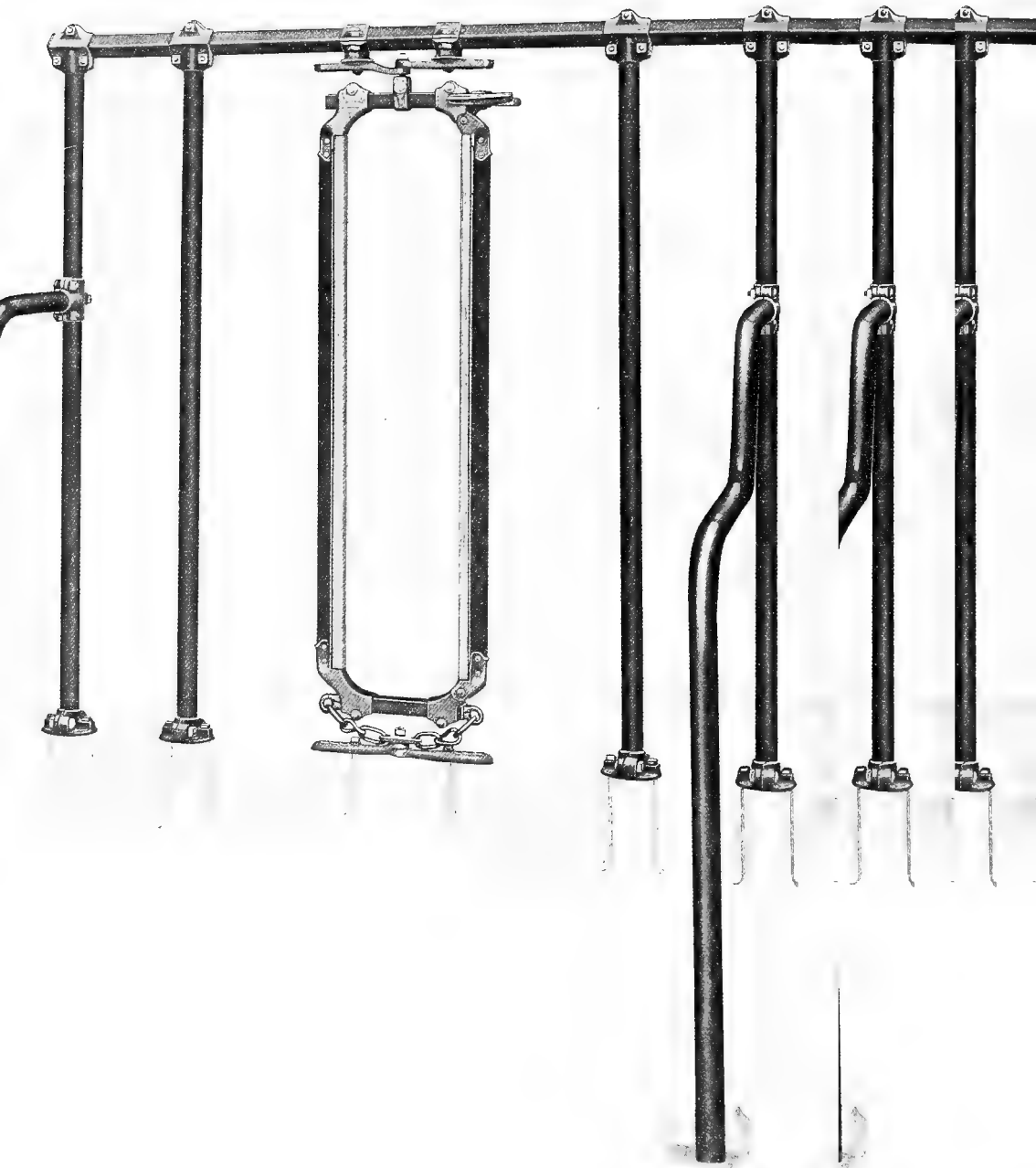
**FINISH:** The steel is first mechanically cleaned removing scale, grease and foreign matter, thoroughly preparing the material for painting; it is then finished with the best grade protective enamel, baked for two hours at a high temperature. (See page 129.)

**MANGER PATTERN:** Will be furnished free or on request; made of hardwood exact shape of manger partition bottom, that manger trough in the concrete may be so shaped that the James complete manger or the manger division, depending on pattern used, will fit accurately if you later wish to add the mangeers to the stalls. See page 124. Be sure to specify the style of manger pattern wanted—pattern No. 1 for the complete mangers and pattern No. 4 for the manger division. Pattern No. 4 will be sent with all steel stall orders unless No. 1 is specified.

**WIDTH OF STALL:** We carry in stock 3 feet 2 inches, 3 feet 4 inches and 3 feet 6 inches. 3 feet 6 inches width will be furnished if not otherwise specified.

**WEIGHT:** About 115 pounds per stall.

Shipped assembled, knocked down for convenience in handling and ease of erection. (Page 127.)



BILL STALL

## James Bull Stall

PATENTED

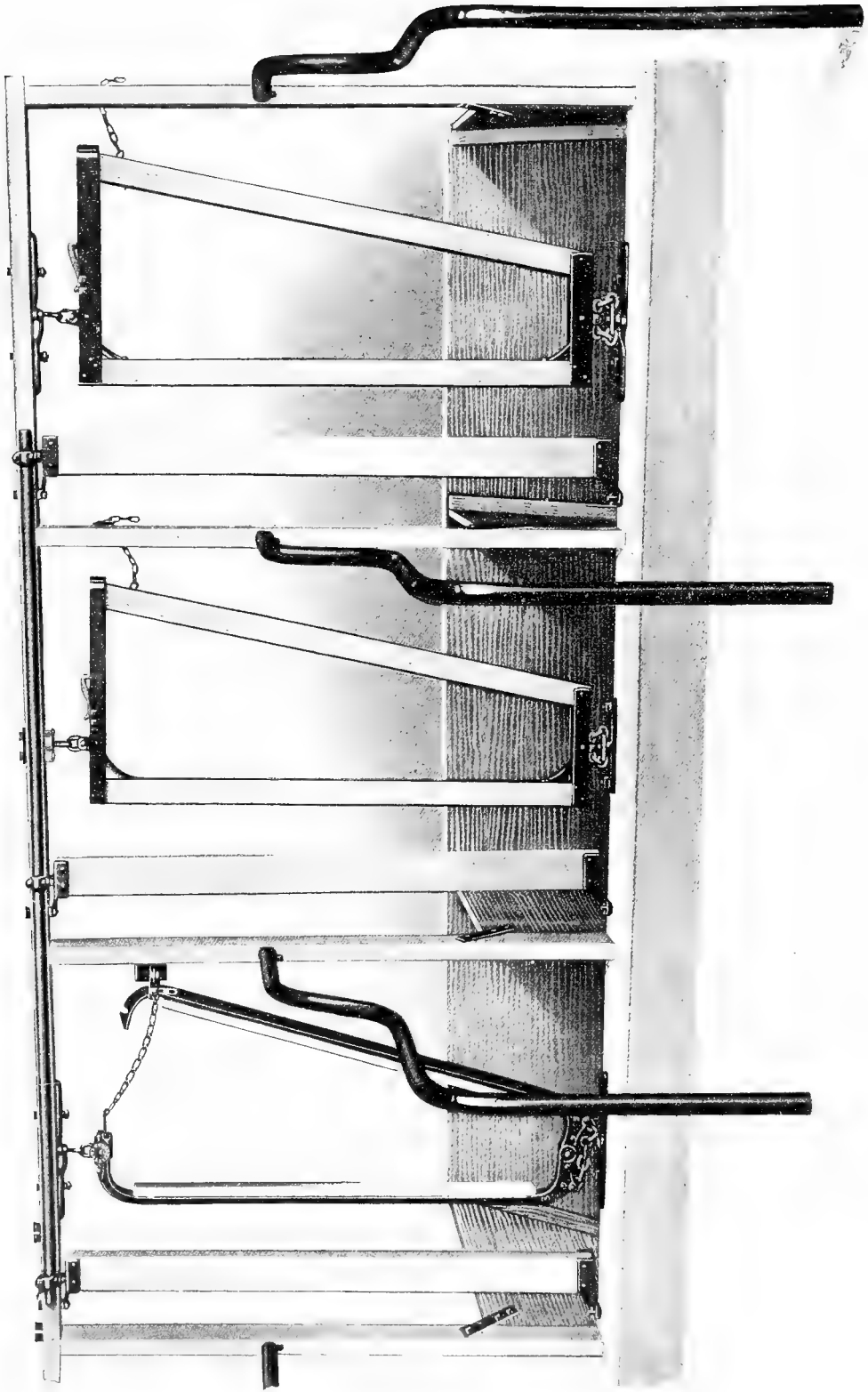
### SPECIFICATIONS

- FRAME:** Upright stall posts are of pipe,  $1\frac{5}{8}$ -in. outside diameter, thickness of pipe wall about .14 inch; horizontal is of same material,  $1\frac{1}{2}$  in. x  $1\frac{1}{2}$  in. square, thickness of wall about .13 inch. Patent applied for. (Page 113.)
- PARTITIONS:** James Triple Curve Stall Partitions as described on page 115. Made of pipe  $1\frac{5}{8}$ -in. O. D., thickness of pipe wall about 1-7 inch, with malleable anchor flange for concrete floor. Partition anchors, extra. (See page 116.)
- WIDTH OF STALL:** Four foot width will be furnished if not otherwise specified. Stall cannot be furnished less than four feet wide.
- FITTINGS:** Best malleable, size and strength, sufficient to withstand all strains. Dust proof type. (See page 114.)
- ANCHORS:** Heavy galvanized steel, 2 inches wide, for stall post anchors. Templates attached to make accurate setting of anchors easy. Anchors are only part of stall required at time concrete is laid; stall easily attached to anchors at any time later. (Patented.) (See page 122.)
- STANCHION:** James Stanchion No. 1C15, described on page 165. Patented. Neck space adjustable from 5 inches to 10 inches. James alignment device; lock open clip; James double chain hanger with three flat and six round steel links; James anchors; side bars of carbon steel tees,  $1\frac{1}{2}$  x  $1\frac{1}{2}$  x  $\frac{3}{4}$ 6-in., lined with thoroughly seasoned birch securely attached. Strong hinge. Bull proof lock.
- FINISH:** The steel is first mechanically cleaned, removing scale, grease and foreign matter, then followed with a chemical bath, thoroughly preparing the material for painting; it is then finished with the best gray protective enamel, baked for two hours at a high temperature. (See page 129.)
- WEIGHT:** About 110 lbs. per stall.
- MANGER:** If manger is desired, one should be built of concrete. Regular manger is never furnished. Stall never furnished without the two extra posts in frame.

Shipped assembled, knocked down for convenience in handling and ease of erection. (Page 127.)

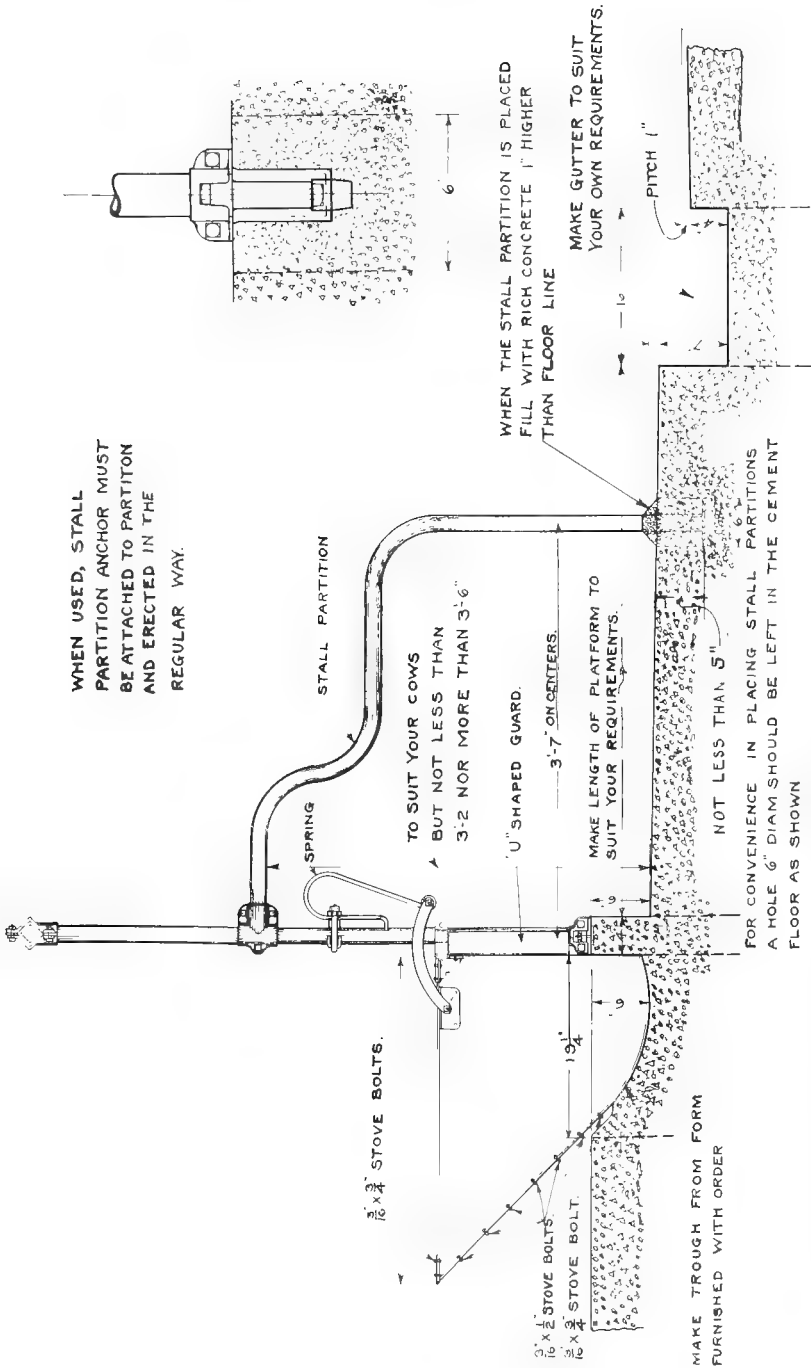
There seems to be a demand for a bull stall to be built in with a row of cow stalls, where no provision is made for a bull pen. To meet this condition, we furnish the above stall, which will accommodate the average bull not older than two or two and a half years.

This stall is also recommended for large Holsteins.

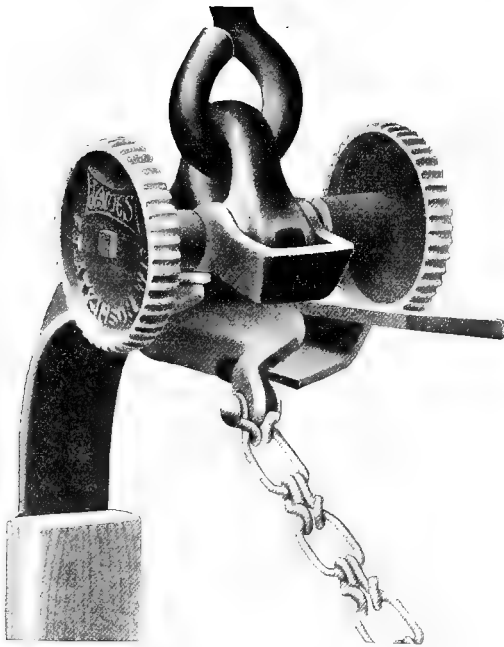


James Wood Stalls, with Stations J14, W18 and WA18 respectively. Without James Anchor.  
Height of Wood Frame in the Clear is 4 ft. 5 1/4 in.

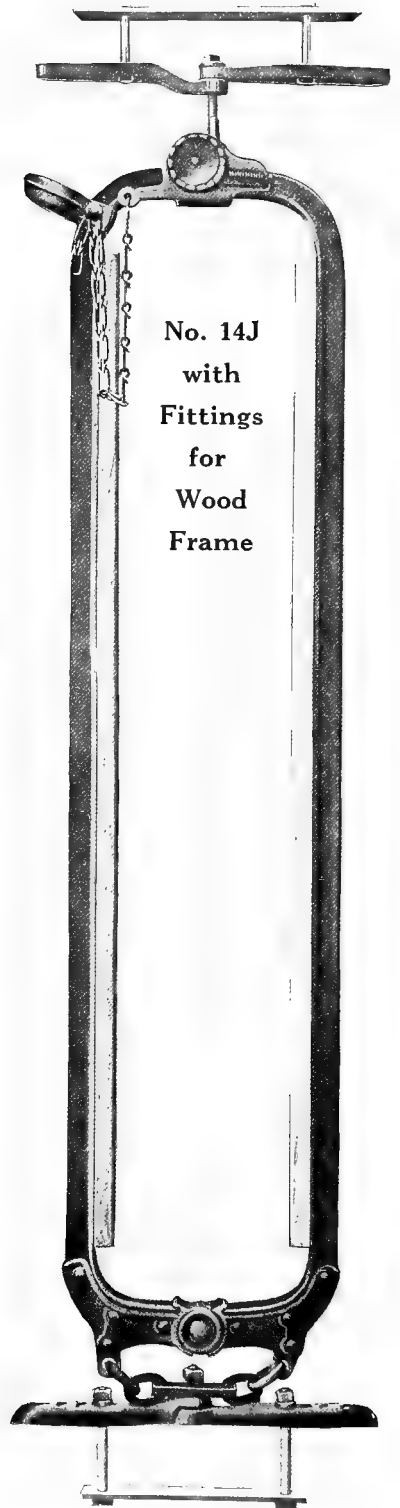




A specially prepared plan is supplied for use in connection with the erection of every equipment order. This plan embodies all the necessary measurements to be used. In addition to this plan we send a very complete book of printed instructions, any dimensions you may desire to know in advance of the receipt of the erection plan, and printed instructions can be obtained from the cut here shown.



Showing Clamp for Steel Frame  
No. 14J Stanchion



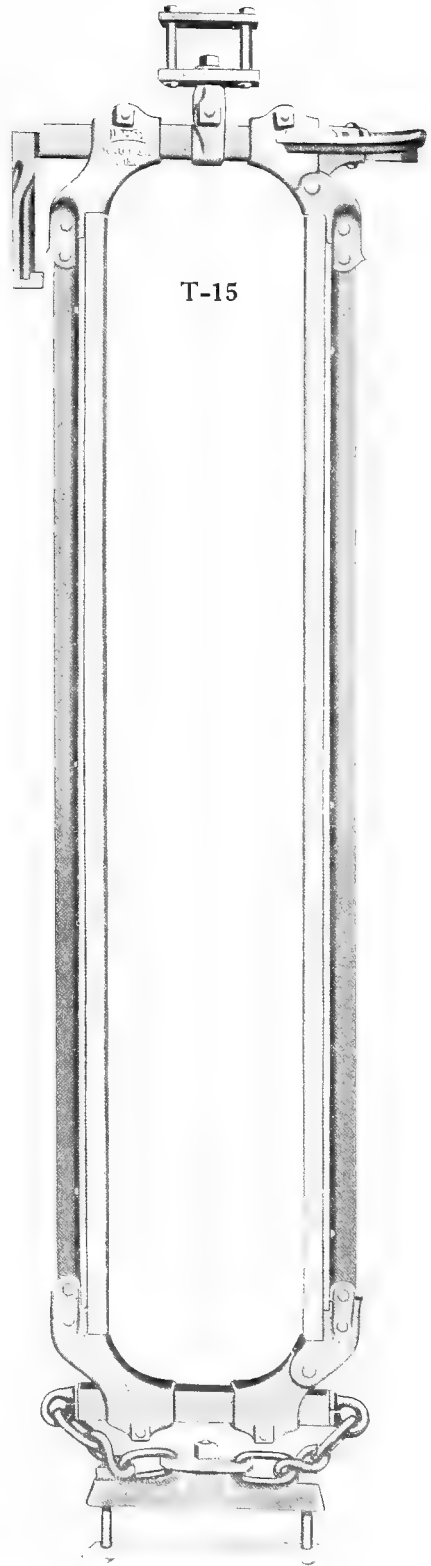
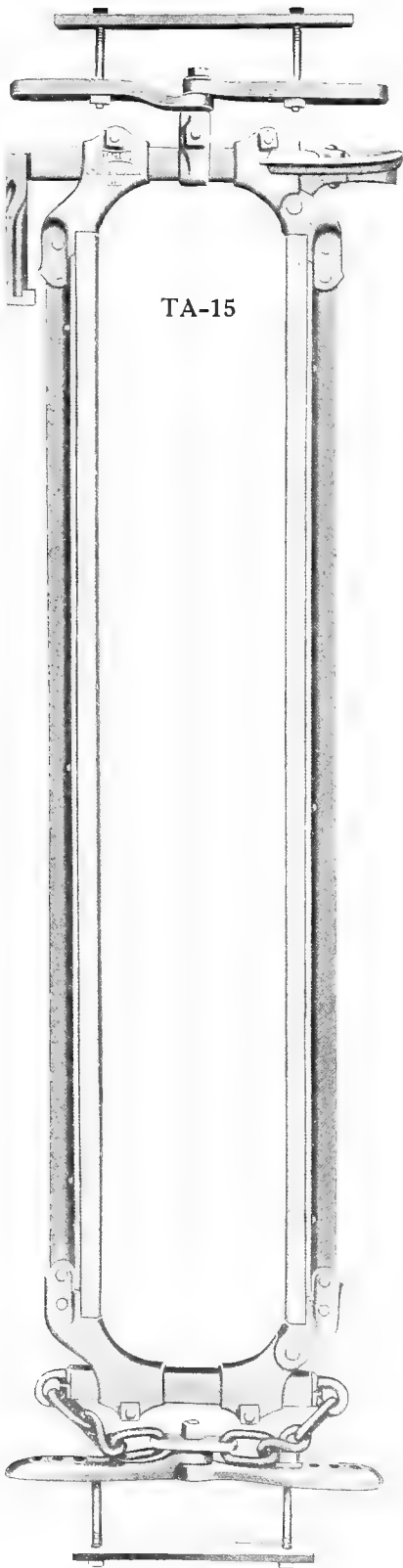
No. 14J  
with  
Fittings  
for  
Wood  
Frame

## James Stanchion 14J

(PATENTED)

## SPECIFICATIONS

- ALIGNMENT DEVICE:** Best malleable iron. Adjustment  $10\frac{1}{2}$  in. (Page 119.)
- CHAIN GUIDE:** Relieves the strain from the loose arm and the hinge when pressure is thrown on this loose arm while not engaged on the stall post; limits the distance the stanchion opens, and takes strains off the hinge when the stanchion is not closed.
- DOUBLE CHAIN HANGER:** Seven links, three flat steel and four round, attached to stanchion with  $\frac{5}{16}$ -in. rivets, to alignment irons with  $\frac{1}{2}$ -in. machine bolt. (Page 109.)
- WASHER PLATES:** For wood frame two plates are furnished at additional charge, one for top and one for bottom, with four carriage bolts for 2 in. x 4 in. frame  $\frac{7}{16}$  in. x 3 in., with lock washers. Longer bolts extra.
- HINGE:** Two-piece, interlocking hinge of best malleable; diameter  $2\frac{1}{8}$  in., giving a wide bearing surface; attached with six  $\frac{1}{4}$ -in. rivets; rivet in center of hinge  $\frac{7}{16}$ -in. (See page 111.)
- SIDE BARS:** Carbon steel tees  $1\frac{1}{4}$  in. x  $1\frac{1}{4}$  in. x  $\frac{3}{16}$  in. All bends and holes made by special machinery, insuring uniformity and perfect working fit of hinge and lock.
- WOOD LINING:** Thoroughly seasoned birch, carefully milled, shaped, polished and oiled. Carefully fitted to tees and securely attached. (See page 109.)
- LOCK OPEN CLIP:** Malleable iron attached with  $\frac{5}{16}$ -in. carriage bolt. (Page 105.)
- COW PROOF LOCK:** Of malleable and steel. Door knob type; can not be opened by the cow—but can be opened easily as a door even when the cow is pulling back. Best quality coiled spring  $\frac{1}{2}$ -in. diameter. Will not break or lose its tension. Locks automatically when stanchion is closed. (See page 113.)
- NECK SPACE:** 7 in. regularly furnished. Neck space may be made 6 in. to  $7\frac{1}{2}$  in. by the use of thicker or thinner linings.
- RIVETING:** Huge presses, fifty tons pressure, form the rivet heads to shape, without crystallizing the metal—rivet heads will never break off.
- FINISH:** The steel is first mechanically cleaned, removing scale, grease and foreign matter, thoroughly preparing the material for painting; it is then finished with the best gray protective enamel, baked for two hours at a high temperature. (See page 129.)
- WEIGHT:** Approximately 27 pounds.



## James Stanchion TA 15

(PATENTED)

### SPECIFICATIONS

- ALIGNMENT DEVICE:** Best malleable iron. Adjustment  $10\frac{1}{2}$  in. (See page 119.)
- DOUBLE CHAIN HANGER:** Seven links, one flat steel and six round. Attached to stanchion with malleable castings, and to the aligning irons with  $\frac{1}{2}$ -in. machine bolts. (Page 109.)
- WASHER PLATES:** For wood frame two plates are furnished at additional charge, one for top and one for the bottom, with four carriage bolts for 2 in. x 4 in. frame  $\frac{7}{16}$  in. x 3 in., with lock washers. Longer bolts extra.
- HINGE:** Is in lower right hand corner; is extra strong, and has no openings to catch dirt.
- SIDE BARS:** Carbon steel tees,  $1\frac{1}{4}$  in. x  $1\frac{1}{4}$  in. x  $\frac{3}{16}$  in. All holes made by special machinery, insuring uniformity and perfect working fit of hinge and lock.
- WOOD LINING:** Thoroughly seasoned birch, carefully milled, shaped, polished and oiled. Carefully fitted to tees and securely attached. (See page 109.)
- LOCK OPEN DEVICE:** Is formed by the handles of the lock. Lock open pipe may be moved on the horizontal to conform to width of the stall; for this reason no fitting is furnished to attach lock open pipe to stall post.
- COW PROOF LOCK:** Of malleable. Absolutely cow proof. Easy to open with the hand; locks automatically when stanchion is closed.
- NECK SPACE:** Adjustable from 5 in. to 9 in. Adjustment can be easily and quickly made, requiring only the loosening of two nuts at the top and two at the bottom.
- RIVETING:** Huge presses, 50 tons pressure, form the rivet heads to shape, without crystallizing the metal. Rivet heads will never break off.
- FINISH:** The steel is first mechanically cleaned, removing scale, grease and foreign matter, thoroughly preparing the material for painting; it is then finished with the best gray protective enamel, baked for two hours at a high temperature. (See page 129.)
- WEIGHT:** Approximately 30 lbs.

## James Stanchion T 15

(PATENTED)

Identically the same as Stanchion No. TA15, excepting that the alignment irons are omitted.

Weight: Approximately 23 lbs.

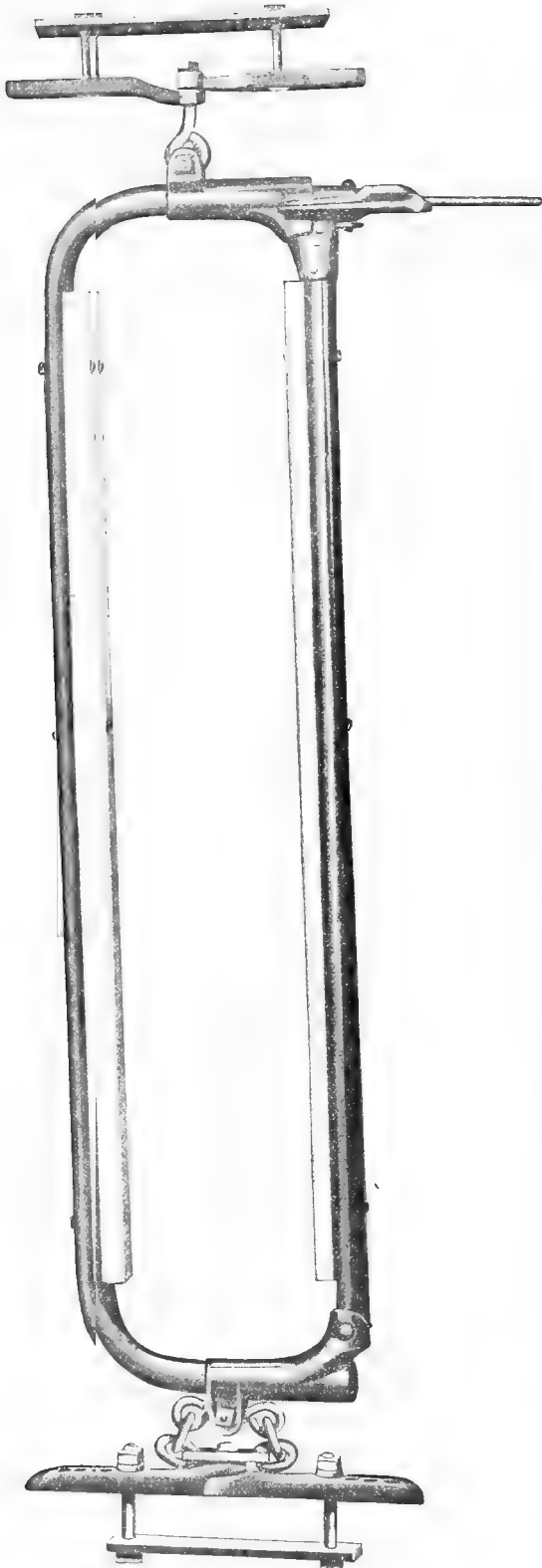
## James Stanchion TC 15

(PATENTED)

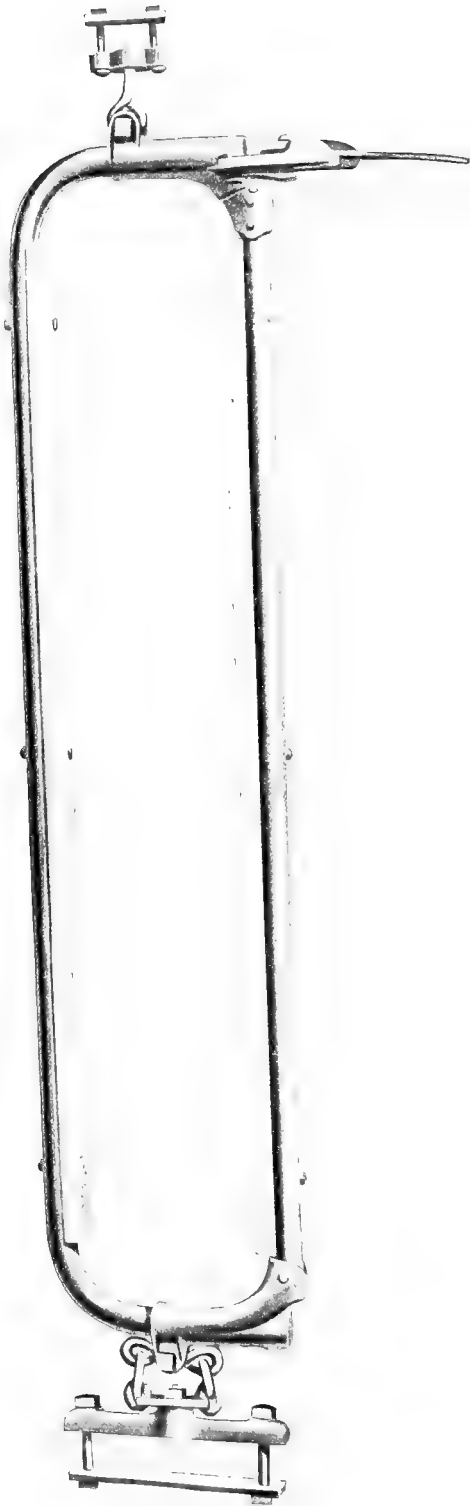
Same as Stanchion No. TA15, excepting that side bars are  $1\frac{1}{2}$  in. x  $1\frac{1}{2}$  in. x  $\frac{3}{16}$  in. and hinged extension of the guide bar (shown at upper left of stanchion illustration) is not furnished.

Weight: Approximately 33 lbs.

Neck Space: Adjustable from 5 to 10 inches.



XA18 Stanchion



X18 Stanchion

With Fittings for Wood Frame

# James Stanchions—Nos. X18 and XA18

(PATENT APPLIED FOR)

## SPECIFICATIONS

### No. XA18

**ALIGNMENT DEVICE:** Best malleable iron. Adjustment 10½ inches. (Page 119.)

**WASHER PLATES:** For wood frame two plates are furnished at additional charge, one for top and one for the bottom, with four carriage bolts for 2 in. x 4 in. frame ⅞ in. x 3 in., with lock washers. Longer bolts extra.

**SIDE BARS:** Made from 1⅝-inch O. D. steel pipe.

**WOOD LININGS:** Of ⅝ x 1⅜-inch thoroughly seasoned birch, carefully shaped, polished and oiled. Fastened to side arms by six ¼ x 2⅛-inch finhead bolts, which form no projections for the cow's neck to rub against.

**NECK SPACE:** Adjustable from 6 inches to 8½ inches. The stanchion neck space top and bottom adjusters are best malleable iron.

**CHAIN HANGER:** Six links, four round, one flat and one special double-eye link. Attached to alignment irons with ½-inch machine bolts.

Two plates furnished; one for top and one for bottom, with four carriage bolts for 2 x 4-inch frame, bolts ⅞ x 3-inch, with lock washers. Longer bolts extra.

**STEEL GUIDE:** Relieves the strain from the loose arm and the hinge, when pressure is thrown on this loose arm while not engaged on the stall post; limits the distance the stanchion opens.

**LOCK OPEN CLIP:** Malleable iron. Attached with ⅝-inch bolts.

**COW-PROOF LOCK.**

**FINISH:** The steel is first mechanically cleaned, removing scale, grease and foreign matter, thoroughly preparing the material for painting; it is then finished with the best gray protective enamel, baked for two hours at a high temperature. (See page 129.)

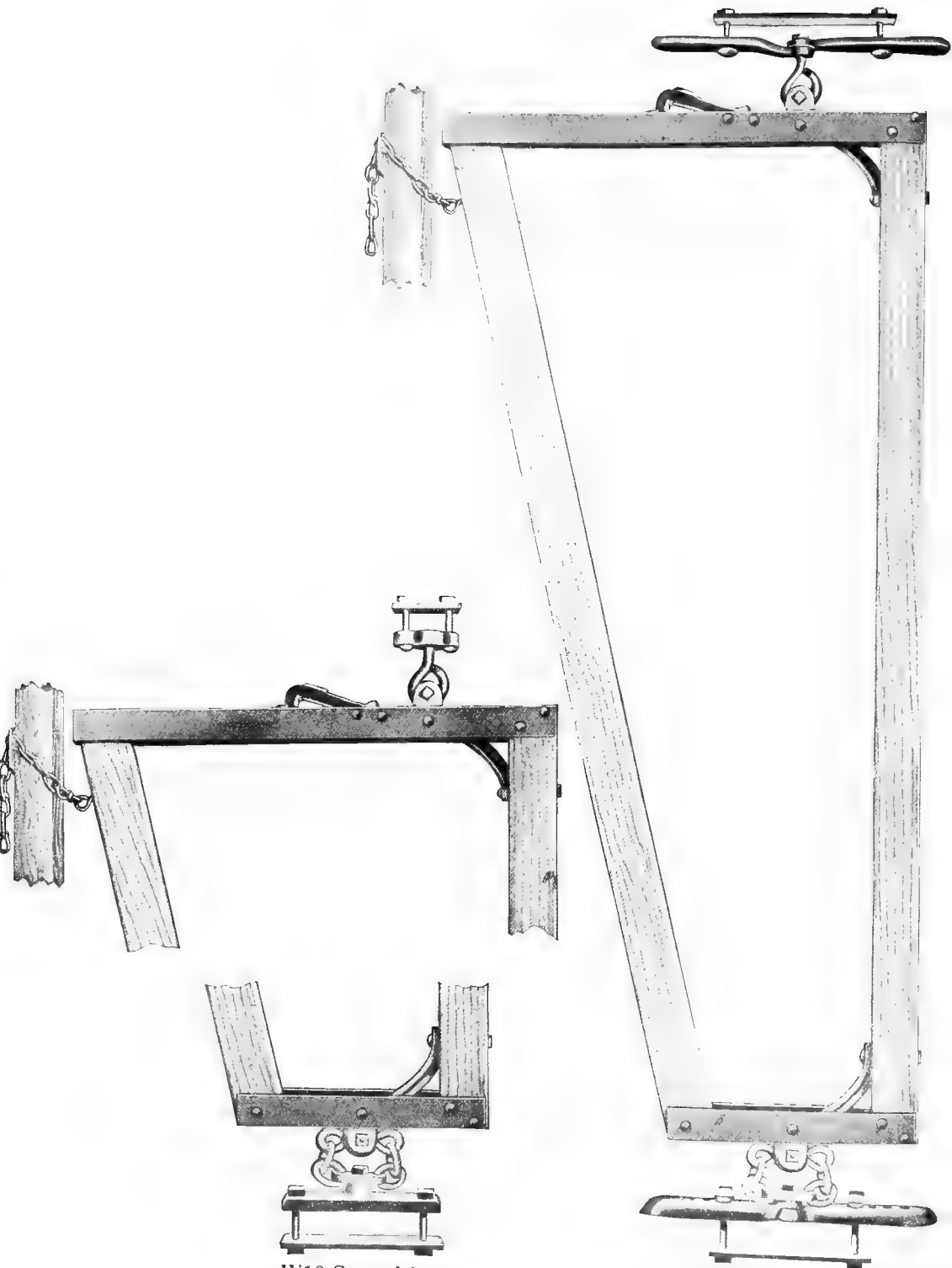
**WEIGHT:** Approximately 27 lbs.

## James Stanchion No. X18

(PATENTED)

Identically the same as XA18, excepting that the alignment device is omitted.

**WEIGHT:** Approximately 25 pounds.



W18 Stanchion

With Fittings for Wood Frame

WA18 Stanchion



## James Stanchion WA18

(PATENTED)

### SPECIFICATIONS

**ALIGNMENT DEVICE:** Best malleable iron. Adjustment 10½ inches. (See page 119.)

**CHAIN HANGER:** Six links, 1 flat, 4 round and 1 special double-eye link. Top fastener is ½-inch round steel eye.

**WASHER PLATES:** For wood frame two plates are furnished at additional charge, one for top and one for the bottom, with four carriage bolts for 2 in. x 4 in. frame 1½ in. x 3 in., with lock washers. Longer bolts extra.

**SIDE BARS:** Of well seasoned hard maple 2½ x 1½ inches, carefully milled, shaped, polished and oiled. Ends riveted crosswise, to prevent splitting. Fastened to top and bottom plates with rivets. Reinforced by heavy malleable braces, riveted to the stick and riveted to the steel plates; no racking in the corners, the strain being equally distributed.

**TOP AND BOTTOM PLATES:** Heavy carbon steel 2 inches wide and a trifle over ⅛-inch thick, carefully punched by special machinery, insuring perfect fit for all rivets. A steel plate at the top forms a guide for the loose arm of the stanchion and prevents it from dropping to the floor.

**COW-PROOF LOCK:** Malleable iron. Simple, cannot get out of order. Easily unlocked with gloved or mittened hand, but cannot be opened by the cow. Locks automatically when stanchion is closed.

**NECK SPACE:** 7½ inches.

**LOCK OPEN CHAIN:** James Chain Lock Open Device and Clip, as shown in illustration.

**RIVETING:** Machine riveted.

**FINISH:** The steel is first mechanically cleaned, removing scale, grease, and foreign matter, thoroughly preparing the material for painting; it is then finished with the best gray protective enamel, baked for two hours at a high temperature. (See page 129.)

**WEIGHT:** Approximately 22 pounds.

## James Stanchion W18

(PATENTED)

Identically the same as Stanchion WA18, excepting that the alignment irons are omitted.

**WEIGHT:** Approximately 15 pounds.



# How James Cups Increase Milk Yields

Those who realize how greatly milk flow is increased by the use of James cups, permitting cows to drink all the water they want, when they want it, whether day or night, are making \$10, \$15, yes, even \$20 and more per cow extra profit each winter.

And they are doing this merely by giving cows all the water they need. Water costs practically nothing. Feed costs—well, it costs enough.

How wonderfully James drinking cups increase dairy profits is shown by a recent investigation among farmers using them.

A list of questions was sent out to which 120 replies giving definite information were received.

These replies came from practical farmers, for the average size of the herds was 24 cows. 5 of the herds had less than 10 cows; 61 had 10 to 20 cows; 27 herds had 21 to 30 cows; 10 had 40 cows; 4 had 41 to 50 cows; and 6 had from 51 to 100 cows each.

Of the 120, 108 said that James cups increased their milk yields; only 5 said they noted no increase; and the other 7 did not answer this question.

Out of the 108 who said that the drinking cups increased the milk yield 69 gave definite figures on the amount of increase, 28 basing their statements on milk records and 41 basing their statements merely on an estimate.

It is striking, however, that the average of the reports based on milk records checked very closely the average of the 41 reports based on estimates.

Of the 28 reports on actual milk records, one reported an increase varying from 5 to 10 pounds per cow per day; 4 report an average increase of 4 pounds per cow per day; 3 state 3 pounds; 5 say 2 pounds; 3,  $1\frac{1}{2}$  pounds; 1,  $\frac{3}{4}$  pounds; 1 reports \$8.56 increase per cow for the winter 1917-1918; one \$5.00; one \$10.00; one received 3% increase; one 8%; two 10%; one  $12\frac{1}{2}$ %; one 20%; one  $33\frac{1}{3}$ %; and one merely says "not much."

These 28 reports cover 759 cows, the average herd being 27 cows.

To reduce the above figures to an average, let us assume that 16 pounds daily is an average milk yield for good cows and that \$3.25 per hundred was the average price of milk. This would make the average increase per cow per day for each of the 759 cows 2.45 pounds.

Of the 41 who based their statements on estimates instead of on milk records, 5 report an increase of 1 pound per cow per day; three of  $1\frac{1}{2}$  pounds; five 2 pounds; four 3 pounds; five 4 pounds; one 5 pounds; one 10 pounds; one reports a slight increase; one reports  $\frac{1}{2}$  pound increase; one "considerable;" two report 25%; two 20%; one 15%; three 10%; two 5%; two say \$10.00 per cow during the winter; one \$5.00; and one says 50c per cow per month.



These replies show an average increase daily per cow of 2.52 pounds.

Right here we would like to quote from a few of these letters from users of James cups who base their statements on milk records. Anyone who desires may have many more such letters by asking for a copy of our Educational Department Bulletin No. 4.

W. H. Martin, Herdsman Arcady Farm, Lake Forest, Illinois, says: "According to our milk records James cups increased our milk yield 4 pounds per cow per day."

Mr. Curtis O. Merrill, Framingham, Mass., states: "Our milk records show that James cups increased the milk yield from 2 to 4 pounds per cow per day."

In Hoard's Dairyman, April 5, 1918, under the heading "Cow Testing Association Reports" a cow tester writing for the Chehalis District, Washington, says: "One man installed individual drinking cups and the daily milk flow immediately increased nearly 4 pounds per animal."

Mr. Willard C. Owen, Mokena, Ill., says: The James cups are a good investment. The output of milk from my herd increased from 56 gallons to 64 gallons per day within three days after installing the cups." (This is an increase of almost 15%.)

L. F. Duggan, Gainesville, N. Y., writes: "My tenant says the James cups increased the milk yield 30 pounds a day for ten cows, this being shown by the milk records."

D. D. Decker & Son, South Dayton, N. Y., basing the statement on their milk record reports an increase of 20% as the result of using James cups.

These letters are but fair samples of reports that reach us day by day.

## How Water is Turned to Milk

A little thought makes clear the reason why James cups so greatly increase milk yields and dairy profits and how it is that they turn water into milk.

Milk is 87% water.

To make milk, cows must have water just as they must have feed.

To make maximum yields of milk, cows must have all the water they want, whenever they want it day and night.

Most cows make too little milk because they get too little water.

The average dairy cow, when producing her maximum, drinks 15 to 18 gallons of water daily; high producing cows drink more. It is recorded that one famous dairy cow giving 700 pounds of milk a week drank nearly a barrel of water a day, or about 3 pounds water for each pound of milk.

Drinking an average of 15 gallons water daily, 20 cows would require 300 gallons water each 24 hours; 30 would need 450 gallons; 40 cows 600 gallons; 100 cows 1,500 gallons.



Dairy Barn  
University of Wisconsin  
Equipped the James Way

Now a cow is not a camel—and you can't water her like one without cutting down her milk production.

She has not the ability to store water until she needs it for digestion of food. She drinks just about as much as she needs at the time she is drinking. You can't put her at an icy trough and get her to drink to supply her future needs.

You might just as well cut down on your feed as to fail to provide your cows with all the water they want exactly when they want it—not hours after they want it, nor the next morning, but exactly when digestion demands it. A cow to produce the best results should never be allowed to get very thirsty. Water should be before her where she can drink whenever she wants it, as much or as little as she wants day or night. For cows will drink almost as much at night as in the day.

The cow that is turned out to drink in the trough in the yard once or twice a day, is thirsty most of the time. This means that her digestion is demanding water to digest food—to make milk—is demanding a little water at a time, an exact amount for every pound of food that enters her stomach. Not having the water when she needs it, she is not able to make as much milk.

The reason she drinks so heartily at the trough when she does, is because she has been thirsty so long—but the water she drinks then is of no use in digesting food taken into her stomach during the thirsty spell. Her digestion has done the best it could without water; the milk-making elements which have been wasted for lack of water is pure loss.

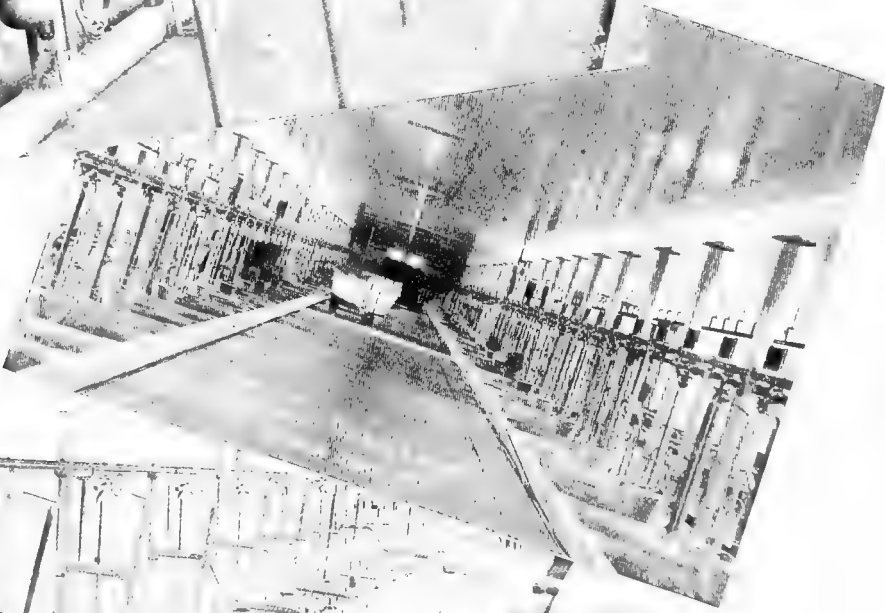
And the thirsty cow turned out to water—how often we see her shivering through a cold unsatisfying drink of icy water, either drinking too little because the water is icy cold, or because of great thirst drinking so much ice water that she must use expensive feed to warm herself again. It is a money-losing proposition to turn feed into heat which, under proper conditions, would have gone to the making of milk.

### Stop the Winter Slump in Milk Yields

James drinking cups will stop the winter slump in your milk yield. Cold weather thirst—the great thief of the winter milk-pail—vanishes completely when James drinking cups are installed.

When your herd is watered the James Way, each of your cows can drink whenever she likes, as much as she likes, at a temperature of water that is most satisfactory, at any minute of the day or night.

Instead of being herded out twice a day to shiver through an unsatisfying drink of ice water, your cows drink to their heart's content right in the warm security and contentment of their stalls any time that their thirst prompts them to do so.



James Dunking Cuts in  
Dunn County Asylum, Barr  
Menomonee, Wis.



There is no more going thirsty three-quarters of the time—no more herding the cows out to drink and herding them in again—no more frozen tanks to chop open—no more tank-heater annoyances or fuel expense—no more twice a day periods of cold and excitement to disturb your herd and interfere with their milk production—no more of that day after day, body-freezing, wind-biting winter chore to worry about in watering your herd.

James drinking cups put an end to all this once and for good.

And just think, too, what it will mean to you to know that if any time a cow in your herd should become diseased, there is no chance for that cow to give the disease to the rest of the herd through the drinking water before the disease is discovered and the affected animal isolated.

James cups prevent the spread of disease for the simple reason that where the individual cups are used, no two cows ever nose the same water. Each cow has her individual cup to drink from. Each cup is fitted with a special valve which allows the fresh water to enter, but prevents the water once in the cups from flowing back and mixing with the general supply.

There is no flowing of water from cup to cup and it is, therefore, impossible for a healthy cow to come into contact with water that has been touched by a diseased cow. Compare this with watering from a common tank, or from the manger-trough.

There are, of course, other ways of passing tuberculosis and other germs, but certainly the common drinking tank or watering from the manger-trough is a dangerous source of infection. You can guard your herd from spread of disease through the water supply by the use of the James cups.

The questionnaire previously referred to also developed other interesting and valuable information.

In response to the question: "Do drinking cups save you time and labor?" the answer was unanimous, 120 answering "Yes."

99 give specific information which showed a daily saving in labor time of  $3\frac{1}{2}$  minutes per cow. This is a total saving of more than 10 hours labor-time in a 200-day season for each cow in the herd.

In answer to the question, "Have you observed that your calves grow better and faster by having a constant supply of water before them?" 80 replied "Yes," 7 answered "No," 11 do not answer and 21 say they are not using cups for the calves.

Answering the question, "Do you consider that drinking cups help prevent spread of disease?" 95 say "Yes," 9 say "No," 8 do not answer and 8 say they are not in position to answer this particular question.

Replying to the question, "Do you consider that drinking cups improve cow health?" 106 answer "Yes," 4 say "No," the balance are not in position to answer.

Answering the query as to whether drinking cups save fuel through not having to use a tank-heater, 108 replied "Yes," 6 said "No." The others did not answer.

61 give definite answers, some in dollars, some in cords of wood and some in tons of coal as to the amount of fuel saved each winter. Figuring the wood at \$5 per cord and the coal at \$7 per ton, the average was 56c per cow, per year saving of fuel through not having to use a tank-heater.

### Let's Figure

Now, let's do a little figuring on this proposition and see just how much a dairy farmer loses each winter by continuing the old way.

Put the average increase in milk yield low—make it 2 lbs. per cow daily. This is 400 lbs. during the usual cold weather season that the cows are in the barn. The price of milk will average more than \$3.00 per cwt. 400 lbs. at \$3.00 totals \$12. That's conservative.

A saving in labor time of 10 hours per cow each winter at 25c per hour is an additional \$2.50.

The saving in fuel is another half dollar.

This makes a total of \$15.00 per cow additional profit per winter, to say nothing of the protection against spread of disease, the saving through better health of the cows, and the greater convenience for yourself or hired man or boys.

The saving in labor and fuel alone almost pays for the cups the first winter. James cups are an investment that pays several hundred per cent profit yearly.

You are losing money every day you are without them. You are wasting fuel, enduring unnecessary disagreeable tasks in watering out of doors, subjecting your cows to danger of spread of disease and getting 2 lbs., 3 lbs., maybe 5 lbs. less milk per cow per day in return for all the expense in feed, labor and care you are giving your herd.

Can you afford to be without James Cups?

## James Watering System is Simple

The James watering system is simple, requiring for the gravity system only the cups; the control tank with regulating valve to maintain a uniform level of water in the cups; a source (such as a supply tank or spring on a level higher than the regulating tank) from which the regulating tank may draw the water; and the necessary piping to connect the same. It is easily installed, and once in requires practically no attention—and the cows have pure, fresh water before them every moment of the day and night.

The level of the water in the cups is regulated by the level of the water in the regulating tank, these levels, of course, being the same. The level of the water in the regulating tank is maintained by a float valve; this regulating tank taking its water from any source having a sufficiently high level to feed regularly.

With the pressure system no regulating tank is required.

## The James Drinking Cups

There are four styles of James drinking cups, a one-cow cup and a two-cow cup for the gravity system and a one-cow cup and a two-cow cup for the pressure system.

One of the best features of these cups is that they are so simple in construction and operation as to be practically trouble proof. They are so easy to install that any dairyman can equip his barn quickly and easily. And being automatic in action, very little further care or attention need be given them once they are in place.

An occasional cleaning is all that is necessary. This is easily done with the one-cow cups by simply removing the cups from the stall posts, dumping the water out and cleansing the cups. It is just as simple a matter to clean the two-cow cups, which is done by removing the drain plug, all loose dirt flushing out as the cup empties; a few strokes with a whisk broom or brush, as the water flows out, completes the job.

The baked on enamel finish provides a smooth, clean surface that does not readily catch deposits or dirt or grime, and is easily kept in sanitary condition.

## Location of Cups

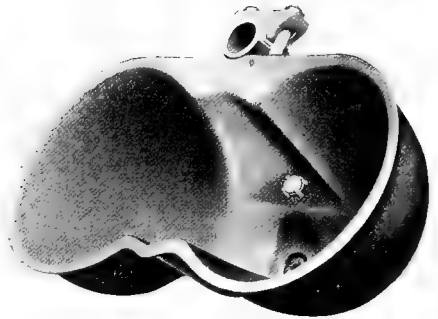
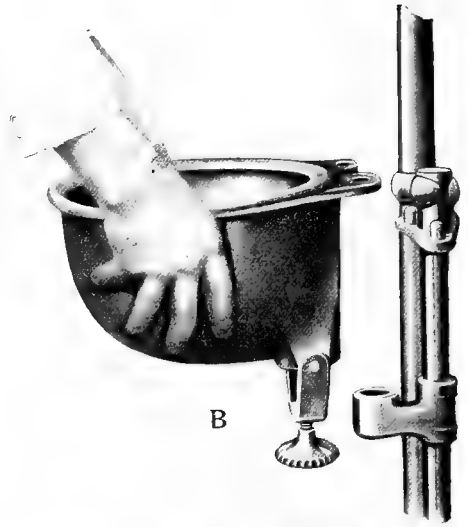
Experience has proven that the location of the cup has a vast deal to do with the amount of dirt that accumulates in it.

Cups located in front of the stall posts to some extent catch hay and feed and thus get dirty quickly. The best location is between the stanchion and the stall post (see page 172 and 174) in which location the cup is kept away from the feed while at the same time it is convenient for the cow. Thus placed, it is surprising how clean the cups will keep.

In this location, too, the cup also acts as a sort of sure stop, filling in the open space where a cow might occasionally put her head when entering the open stall. This location does not prevent raising the mangers, or interfere with the cow's comfort. When standing, she turns her head above the bucket and when lying down, she turns her head below the bucket.

## Location Adjustable

However, the one-cow cups can be placed as desired, the fittings provided making it easy to place the cup in front of the stall post, in back of the post, or at the side.



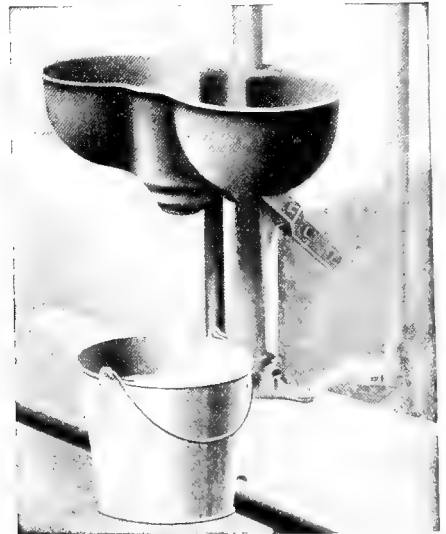
**James  
Drinking  
Cup  
Type 4**

See page 181)

**James Two-Cow Cup  
Type 5. Gravity System**

**Easily Removed,  
Quickly Cleaned**

See Wash Tank page 187



## James Drinking Cup, Type 4 (For Gravity System)

PATENT APPLIED FOR

This cup is extremely simple in construction, consisting merely of the cast-iron cup itself, fitted with a removable valve which allows the water to enter, but prevents it from flowing back.

The construction, the simplicity of the cup, the ease of cleaning, and the method of installation is all made clear by the pictures on pages 180, 181 and 183.



With drinking cup, type 4, a regulating tank is required, as shown on page 183, together with the necessary piping to connect and a constant source of water supply such as a supply tank.

## James Two-Cow Cup, Type 5

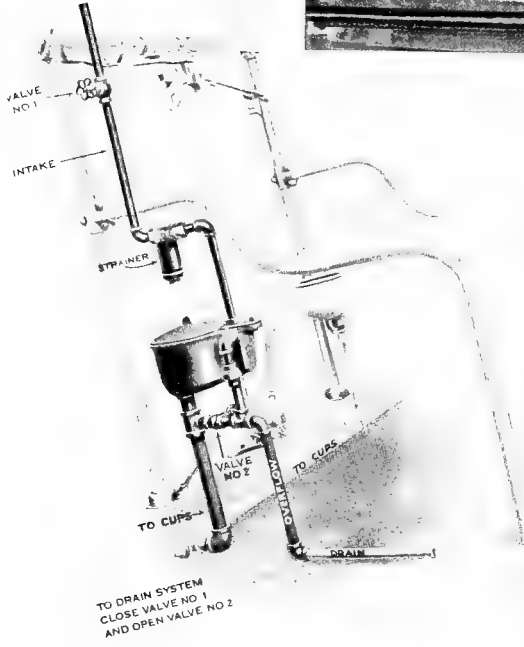
(PATENT APPLIED FOR)

The cup is of cast iron, fitted with the same removable valve used in cup type 4, which allows water to enter but prevents it from flowing back.

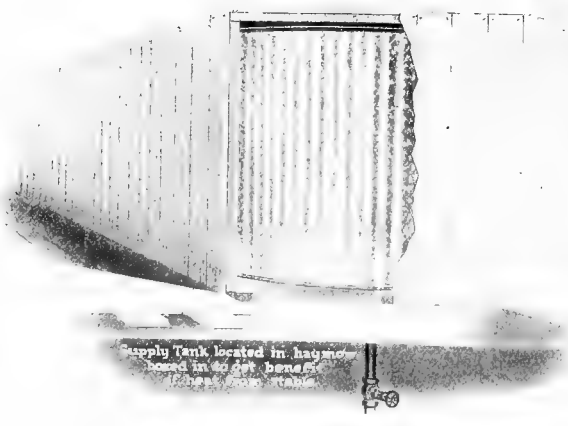
This cup is not removable. Instead, for the purpose of cleaning, it is provided with a large drain plug, which can be readily removed, the dirt flushing out as the water empties. A few quick strokes with a whisk broom or brush while water is flowing out cleanses the cup thoroughly.

Installation is a simple matter, the system requiring only the cups, a regulating tank (page 183) piping to connect and a supply tank or other constant water supply.

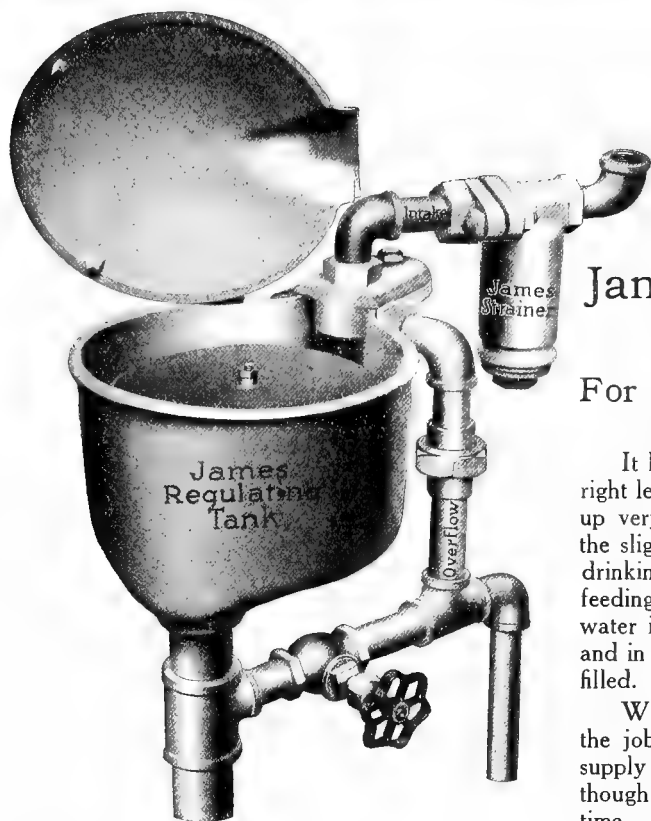
Supply Tank may be  
Suspended from joists



TO DRAIN SYSTEM  
CLOSE VALVE NO 1  
AND OPEN VALVE NO 2



Supply Tank located in basement  
used in hot home  
water tank



## James Regulating Tank

For Cups Types 4 and 5

(PATENT APPLIED FOR)

It keeps the water constantly at the right level in the drinking cups. Takes up very little room. It is sensitive to the slightest outflow of water from the drinking cups, marvelously quick in feeding more water when the level of water in cups is lowered ever so little, and in shutting off water when cups are filled.

With the James regulating tank on the job, your cows are assured a full supply of water, day and night, even though all may be drinking at the same time. It will feed all the water the

pipe will carry, or a drop at a time, just as the cows drinking water from the cups may require.

The greatest obstacle to the success of drinking cup systems heretofore has been the lack of a satisfactory regulating tank—one that is trouble proof and that would maintain a constant supply of water in the cups.

The James regulating tank is wonderfully efficient, its great success being due to an ingenious valve which accommodates itself to varying water pressure.

We regularly furnish a valve seat for pressure up to 15 pounds. For pressure from 15 to 100 pounds, special valve seats will be furnished on customer's orders. When ordering, either the right pressure should be given, or the height of supply tank above the floor.

With your regulating tank so located that its water level is the same as the level desired in the drinking cups, neither cups nor regulating tank can overflow.

It requires such small space that it may be located under a stall partition, if desired, as shown above, either at the end or in the center of a row of stalls or some other out of the way place. It will not interfere at all with the comfort of the cow.

## Strainer

To prevent sand, chips, rust flakes, or other foreign matter getting into feed pipe. An important part of every watering system, whether gravity or pressure.

# James Drinking Cup Type 7

(See page 185)

Easily Removed, Quickly Cleaned.

See wash tank on page 187.

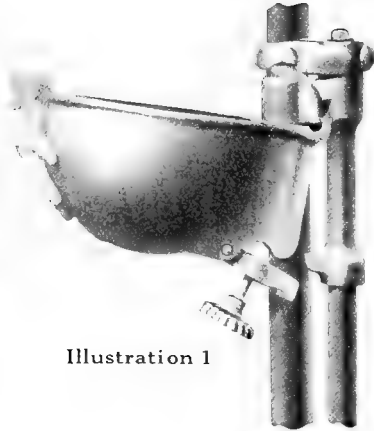


Illustration 1

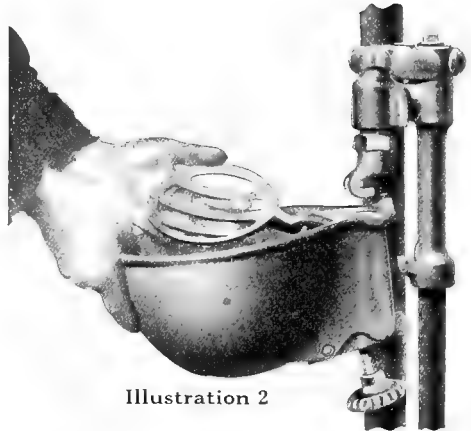


Illustration 2



Illustration 5



Illustration 3



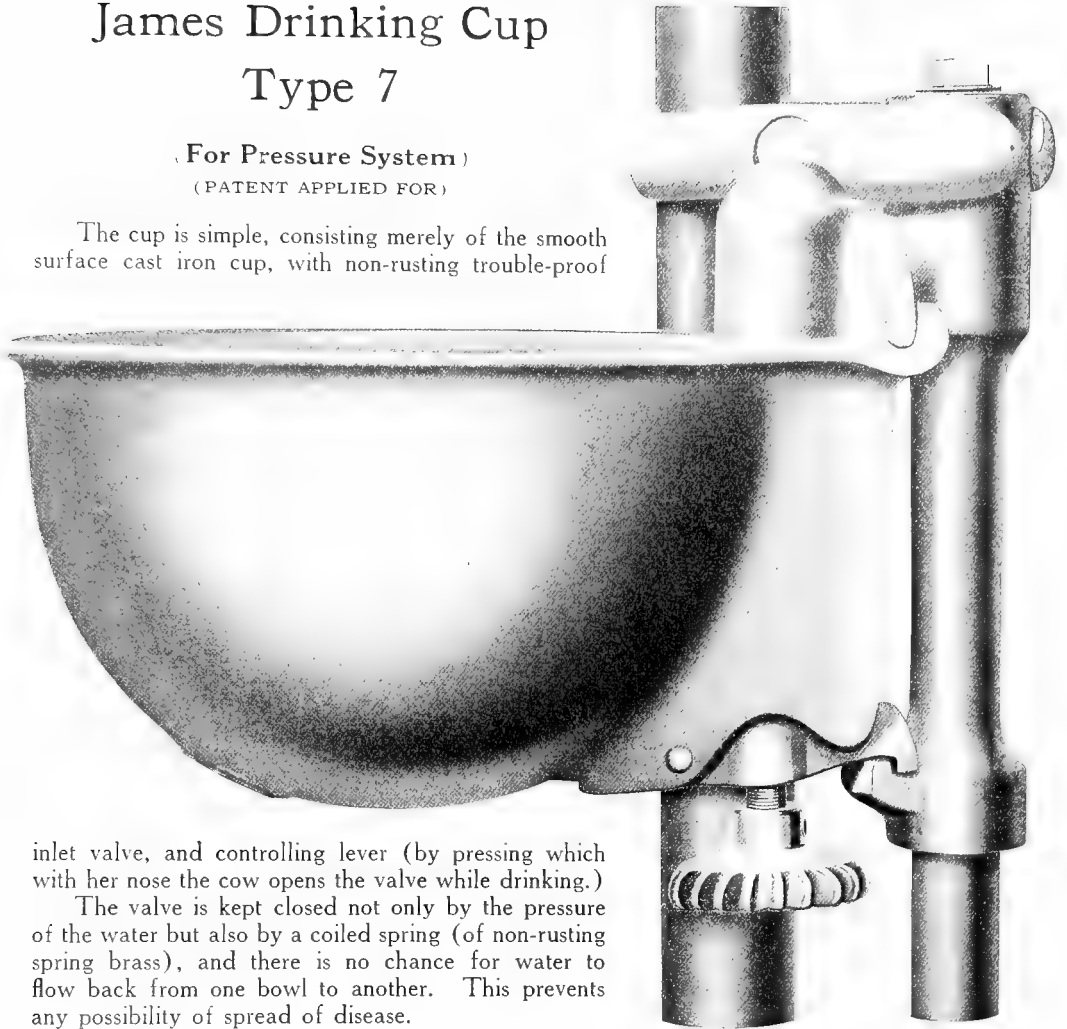
Illustration 4



## James Drinking Cup Type 7

(For Pressure System)  
(PATENT APPLIED FOR)

The cup is simple, consisting merely of the smooth surface cast iron cup, with non-rusting trouble-proof



inlet valve, and controlling lever (by pressing which with her nose the cow opens the valve while drinking.)

The valve is kept closed not only by the pressure of the water but also by a coiled spring (of non-rusting spring brass), and there is no chance for water to flow back from one bowl to another. This prevents any possibility of spread of disease.

### Easy to Clean

The cup is easily removed from the stall post. The water may then be dumped out of the cup, valve lever lifted out and the cup cleansed or sterilized. It is just as simple a matter to replace the cup. The illustrations on pages 184 and 188 make very clear the construction of the cup, its simplicity and the ease of removing from the stall post and cleaning.

### Installation

The upright pipe connecting the cup and the feed pipe is shipped with valve attached, making installation very simple.

The pressure system requires only one size pipe and fittings,  $\frac{3}{4}$ -inch throughout. This pipe fits neatly against the floor and curb entirely out of the way. Or it may be so installed as to feed from above.

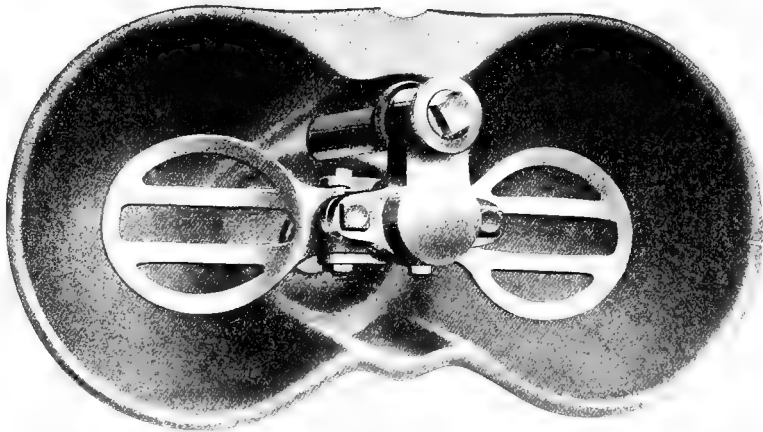
## James Drinking Cup Type 6

(PATENT APPLIED FOR)

This is the same cup as type 5, excepting that a valve similar to that used in type 7, has been substituted for the valve in type 5, so as to adapt this cup to the pressure system.

Provided with a large drain plug which can be readily removed, the dirt flushing out as the water empties. A few quick strokes with a whisk broom or brush while water is flowing out cleanses the cup thoroughly.

No regulating tank is required for either drinking cup type 7 or type 6. The system requires only cups and piping to connect with the water supply.



**James Drinking Cup Type 6. For Two Cows. Pressure System.**

## James Drinking Cup Wash Tank

This equipment makes very simple the matter of cleaning the drinking cups.

The tank, placed on a James milk can truck, can be passed along at the rear of the stalls, the cups lifted from the stall post, emptied into the larger compartment of the tank, then washed in the warmer water which is carried in the smaller compartment.

### SPECIFICATIONS

To be used on truck as shown on opposite page.

Tank made of 18-gauge galvanized sheet steel, strongly reinforced at the top with  $\frac{7}{8}$ -in. x  $1\frac{3}{8}$ -in. x  $\frac{1}{8}$ -in. galvanized angles; all joints securely riveted and soldered both inside and outside.

Divided into two water tight compartments  $17\frac{3}{4}$  inches long, 21 inches wide, 13 inches deep and  $34\frac{1}{2}$  inches long, 21 inches wide, 13 inches deep.

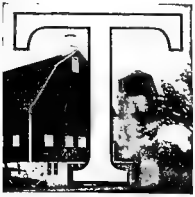
Over-all dimensions of tank are  $24\frac{3}{4}$  inches wide,  $53\frac{3}{4}$  inches long, 13 inches high.

With each wash tank is included a No. 19 Palmetto Garland sanitary brush.





# James Sanitary Steel Pens



THE money to be made in dairy farming depends in no small degree on the care and treatment given the animals.

James Sanitary Steel Pens have been developed to aid in making the dairy barn the biggest profit-maker possible.

And in the building of these pens, the same principles have been followed that underlie the success of James Cow Stalls.

Not only do James Pens confine the animals securely, but they provide the maximum of cleanliness and comfort, and interfere the least with light and proper ventilation, thus promoting health.

They also reduce barn work and pay big dividends on the investment through the saving of labor alone.

## James Pens are Easy to Set Up

The James Pens are most easily erected. They are shipped from the factory already assembled in panels; the gates and the bull pen manger panels are already built. To erect the pens, all that is necessary is to set the corner, intermediate and gate posts in the tubular anchors (which will have already been placed in the concrete curb), bolt the panel to the posts; and fill the tubular anchors with cement. As soon as this cement sets your pen is solid.

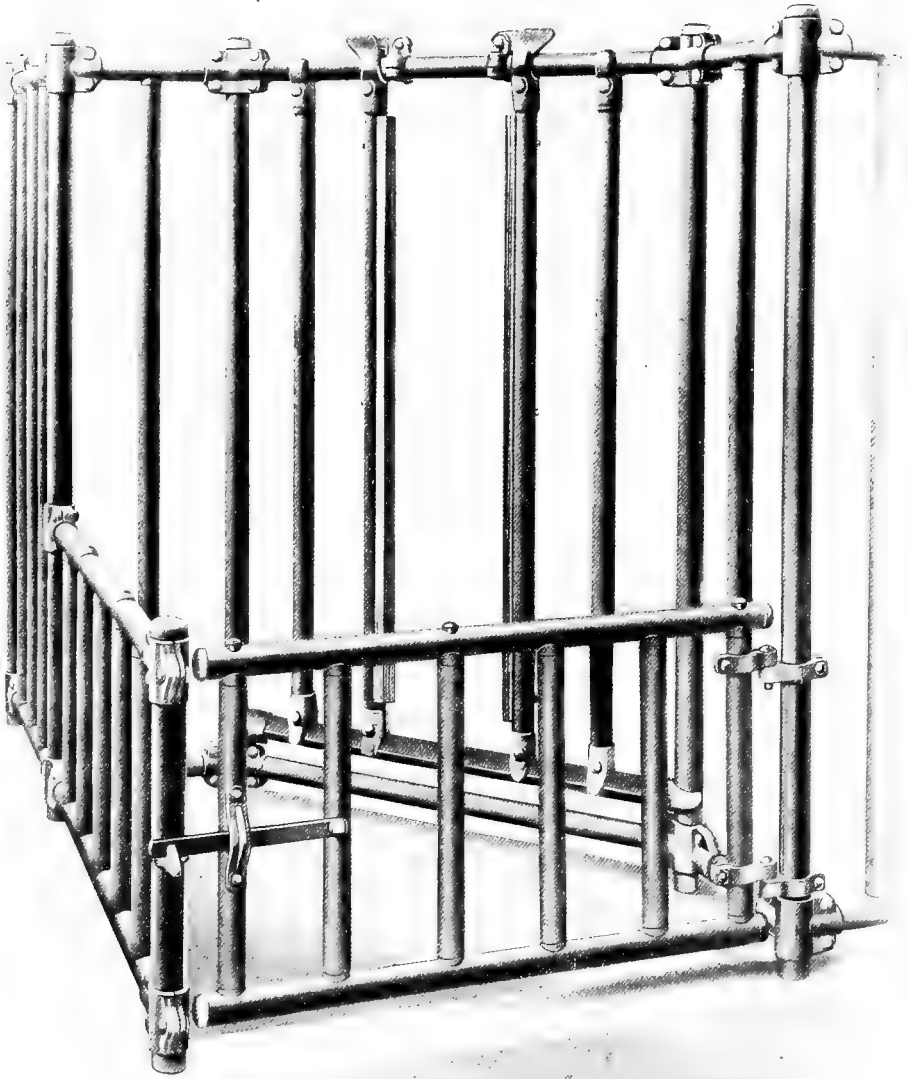
This method effects a great saving in the cost of erection. Formerly, we did not use the panel construction but ran each upright into the cement curb, which required great care and much labor to set up the pens. The cost of manufacturing panel construction pens is a third more than the cost of making the pen where each upright runs into the curb; and likewise it saves you half the expense and difficulty in erection. It is a better pen in every way, but our increasing business makes it possible to furnish it without adding to the price because of this improvement.

## James Tubular Pen Anchors

(PATENT APPLIED FOR)

The anchors are the only part of the pens required at the time the concrete work is done. James Pen Anchors may be secured on short notice either from Fort Atkinson, Minneapolis, or Elmira, N. Y.; Wright-Ziegler Co., Boston; De Laval Dairy Supply Co., San Francisco and Seattle, or some other nearby distributing point. The contractor can go right ahead finishing the cement work according to simple instructions supplied with the anchors. The pens may be set up at any time later when most convenient.

This method makes erection of James Pens so easy that even a boy could do the work and does away with possibility of delay in cementing floors.



James Bull Stanchion and Corner Manger

## Panels and Posts

The corner post, gate post and upright intermediate post extend through the concrete curb and into the solid floor; these posts support the panels and are spaced no farther apart than five feet on centers for bull pens; nine feet for cow pens.

The uprights are held securely to the horizontals at the top and bottom by heavy malleable inserts with sanitary flanges which fit into ends of uprights and into holes drilled in horizontals, making a smooth neat panel that is easy to keep clean. The panels are bolted together by 7/16 in. special bolts, spaced not more than four spindles apart. All bolts used are heavy cut thread bolts—the most expensive kind but which can be depended upon to hold.

This is a new type of panel construction, combining unusual strength with neat appearance and a minimum of dust catching surfaces.

## The Gate Hinge

The hinge on the pen gate is attached not only to the gate and gate post, but runs back to the second upright on both the gate and the panel. The fittings cannot twist under a strain and spring the gate open, as can be done with a gate the hinges of which are attached to but one upright of the gate and one upright pipe of the panel.

## Watering Cups for James Pens

The James individual watering cup may be attached to any James pen and provides the most convenient and sanitary means of watering the animals.

We can also furnish name plates, with fittings to attach to pens.

## Weight of Material

### **Note the weight of James Pens.**

If two competing articles be equally well designed, the greater weight indicates the greater strength.

In these days of high-priced steel and iron, it is easy to save a large amount on the cost of pens, simply by reducing the amount of material used. This might be done and no one be the wiser.

There has been no skimping of material in the manufacture of any of the James equipment. If there be any doubt whatsoever in your mind as to the superiority of James pens, compare for yourself the James pens with that other which you may consider buying.

If it be not possible to compare the actual goods, at least make a careful comparison of specifications. To enable you to do this, we give accurate detailed specifications in the following pages of all the James pens. **Note especially the weight.**



James  
Tubular Pen Anchor



## The James "Safety First" Bull Pen

The James sanitary steel bull pen is the most satisfactory way of keeping the bull. He no longer need be tied by a ring in his nose, but can be turned loose to move about with freedom, within sight of the herd, but where he can do no harm.

The dairy farmer of today realizes that the bull is half the dairy herd. To get the best results from the bull, he must be in first-class condition and of high vitality. He is a big heavy animal and it is cruel to confine him in cramped quarters where he has no means of relief. If you keep him in a stall day after day, his muscles naturally weaken from lack of exercise and his vitality is reduced.

If he is uncomfortable, he gets morose, ugly and hard to handle. When turned loose in a James pen, he has plenty of room to change position, and to get all the exercise that he needs to keep him in perfect condition physically. This maintains his vitality and keeps him in better humor. He is far less apt to become dangerously ugly, than when fastened in a narrow stall; this alone is worth the price of the pen.

Many dairymen emphasize the importance of keeping the bull where he can see the herd; claiming that when he cannot get a view of the herd the best results cannot be hoped for, and that he is even liable to become worthless.

The James bull pen is worth its cost from the standpoint of insurance against accidents, for it vastly simplifies and makes safe the handling of the bull.

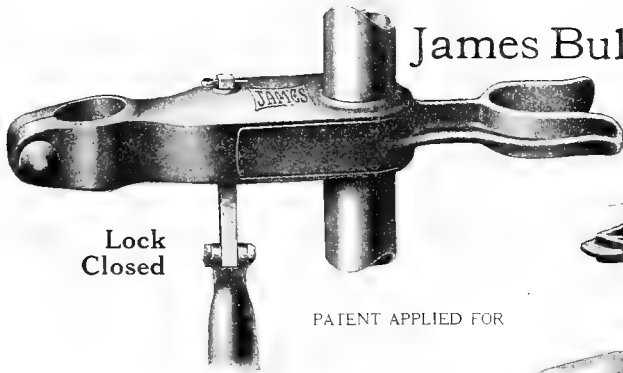
### Safety First

Every man with a family and responsibility believes that insurance is a good thing; you insure your buildings against fire; you insure your automobile; and you insure yourself against death or accident.

You are familiar with the habits of a bull and you know that one does not gradually go mad. He loses his temper in a flash.

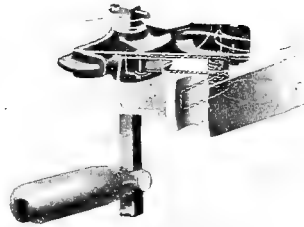
What if there are children who play about the barn? What if this bull should become infuriated and break loose while they are near him? What if you have help which does not know how to handle the animal and he breaks loose and injures or kills your hired man? Under the law, you are responsible for accidents that happen because you do not keep the bull in safe quarters. And you yourself might be helpless if he should try to get you and should break loose from his stall while you are in the barn without protection.

The James Pen is a "safety first" device that no owner of a bull can afford to be without.



Lock  
Closed

PATENT APPLIED FOR



Lock  
Open



Looking at the bull pen merely from the viewpoint of insurance, and disregarding its value in other ways, it is a protection that is cheap at the price.

When necessary to work around the bull, you can easily entice him to put his head through the stanchion by placing feed in the manger and locking him in. He cannot get loose until he is turned loose. You can work about him in perfect safety.

This safe, sanitary and humane means of confining and caring for the bull is just as important as any other part of your barn equipment.

Indeed, at any time it may be of far greater importance, by saving your life or preventing serious injury; and do not forget that the condition of your bull affects the whole herd, for he is directly responsible for just about half the quality of your herd.

In order that the pens may stand the severe strain to which they are subjected, the bull pen corner posts, gate posts and intermediate posts are made of double strength pipe  $1\frac{7}{8}$  in. O. D. with pipe wall  $\frac{1}{5}$  in. in thickness. The posts are so strong that the unsightly, cob-web catching arches over the gates are no longer needed. Being strong enough for the gate, the posts are of course also strong enough at the end of a panel next the wall, the panel does not need to be attached to the wall.

If you realize what a strain a bull pen is put to if a bull weighing a ton or more throws himself against it with all his force, you will see the wisdom of buying a bull pen with James quality of materials and James construction.

The inside walls of the James bull pen have no tilting mangers or feed boxes which the bull can worry and break down by testing his strength. The manger is built of pipe and is just as strong as the rest of the pen. A watering bucket can be attached to the manger so that the bull may have water before him all the time.

The stanchion is adjustable in neck space and has a wood lining which not only adds to strength of stanchion but keeps the neck of the bull from contact with the cold steel when locked in the stanchion. The stanchion is easy to open, but cannot be opened by the bull. It locks by simply slamming shut.

## The Bull Proof Lock

(PATENT APPLIED FOR)

We have developed a new lock for the pen gate that insures safety, for it is so constructed that it never fails to catch when the gate is slammed shut. It is very simple in construction, bull-proof and positive in action. The gate lock cannot be opened except by your hand. The "disappearing" handle must be raised, then turned—two operations which it is impossible for the bull to perform. The upright posts are clean of all projecting fittings and there are no sharp points to jam the bull as he comes in or out of the pen.



James "Safety First" Bull Pen

# James "Safety First" Bull Pen

(Patent Applied for)

## SPECIFICATIONS

**CORNER POSTS:**  $1\frac{7}{8}$  in. O. D. double strength pipe. Used with James Tubular Pen Anchors.

**GATE POSTS:**  $1\frac{7}{8}$  in. O. D. double strength pipe. Used with James Tubular Pen Anchors.

**INTERMEDIATE POSTS:**  $1\frac{7}{8}$  in. O. D. double strength pipe. Spaced not more than 5 ft. apart. Used with James Tubular Pen Anchors.

**PANEL HORIZONTALS:**  $1\frac{5}{8}$  in. O. D. pipe. Top and bottom horizontals bolted together with  $\frac{7}{16}$  in. cut thread bolts, spaced no more than four spindles apart.

**PANEL SPINDLES:**  $1\frac{5}{8}$  in. O. D. pipe spaced  $6\frac{3}{4}$  in. on centers.

**ANCHORS:** James Tubular Pen Anchors  $3\frac{1}{2}$  in. O. D. 9 in. long. Made of 24-gauge steel. These anchors are the only part of the pen required at the time the concrete work is done. (See page 192.)

**FITTINGS:** Best Malleable.  $\frac{1}{2}$  in. cut thread bolts used with fittings for attaching panels to posts.

**ORNAMENTS:** Best malleable; dust proof type.

**GATES:** Frame  $1\frac{5}{8}$  in. O. D. pipe, with  $1\frac{5}{8}$  in. O. D. pipe uprights. All fittings of best malleable. Equipped with heavy bull proof lock. Hinges are of best malleable, offset so that gate will swing back against pen. Half the hinge clamped not only to the gate post but also to the upright next to it; the other half of hinge not only clamped to the gate frame but also to the upright next to it.

**GATE LOCK:** Best malleable. Double latch connected by  $\frac{3}{8}$  in. square steel rod. Gate locks when slammed shut; can be opened only by hand, it being necessary to raise the lever and turn. Cannot be opened by bull. Simple, positive in action, strong. (See page 194.)

**FINISH:** The steel is first mechanically cleaned, removing scale, grease, and foreign matter, thoroughly preparing the material for painting; it is then finished with the best gray protective enamel, baked for two hours at a high temperature. (See page 129.)

**HEIGHT:** Pen is 5 ft. 4 in. from the floor.

**WEIGHT:** 40 lbs. per linear foot.

SHIPPED ASSEMBLED IN PANELS

## James Bull Pen Manger

**CONSTRUCTION:**  $1\frac{5}{8}$  in. O. D. pipe with malleable fittings and dust proof ornaments. Corner Posts  $1\frac{7}{8}$  in. O. D.

**SIZE:** Regularly furnished 26 in. wide, 36 in. long and 28 in. high from floor. Size and shape may be varied to suit conditions.

## James Bull Stanchion

(Patent Applied for)

Side bars of  $1\frac{5}{8}$  in. O. D. double strength pipe with wood linings bolted on. Horizontal at bottom is of square pipe  $1\frac{1}{2}$  x  $1\frac{1}{2}$  in. Fittings are of best malleable.

Neck space is adjustable from 7 to 15 in. Stanchion lock is of safety type. Cannot be opened by bull. Locks when stanchion is slammed shut; of best malleable. (See page 190 for illustration.)

## James Bull Staff

(See Page 311.)



Exact sizes of pipe used



Barn, Fairboro, Pa.



Bull Pen

Census, Pa.

## The James Cow Pens

Cow pens are used for many purposes but generally for sick animals or for animals that for some special reason are being given every advantage for development, growth or production.

Pens are used for animals that need special care.

Whether pens are to be used for increasing production, for hospital purposes, or for growing animals, the great idea to be kept in mind is to so build them as to provide June comfort, light, ventilation and sanitation the whole year around.

This same idea should, of course, always be in mind with barn building, but more especially with pen barns as these are to house animals at critical periods of their lives when they must receive special care.

The James cow pen is constructed of steel paneling which does not obstruct light or hinder ventilation. Cork brick makes a very good substitute for the pasture bed; it saves bedding, avoids udder troubles and the most valuable place for cork brick is for pen floors.

The removable bucket is very necessary especially with the pen used for hospital purposes. Often the animal must not have access to water and often the pen is used for an animal suffering from an infectious disease. There is no other cup so easily cleaned as the James cup, which can be removed, put into a tank and washed, or thoroughly sterilized.

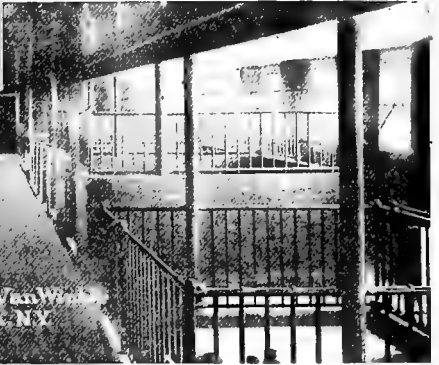
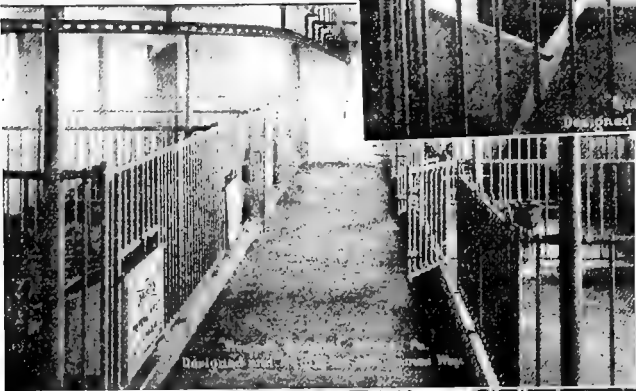
The James cow pen not only provides June comfort for the stock but makes it possible to maintain this condition the year around. It is easily cleaned and in reality is a hospital, a place where any animal can do her best to throw off disease, to produce or to grow.

The old-time wooden box stall is a pest house as soon as the first infectious case is housed in it.

Perhaps the most common use of the cow pen in the average barn is for a freshening pen. This is the most important period for the dairy cow as the manner in which she passes through the critical period has a great deal to do with how she produces during her lactation period.

The cow should be placed in the pen several days before freshening and allowed to get used to it before the calf is born. As soon as the calf is able to walk he should be removed to different quarters and the cow allowed to remain in the pen for several days, after which she is put back in the stall if she is a dairy cow.

Of all the diseases that cattle have abortion is by far the worst. There is no known cure. We know how it spreads. The only way to stop its spread is by sanitation especially at freshening time. An infected freshening pen can easily cause every cow in the herd to abort the following year. One cannot tell what cow may infect the pen and the only safe way is by thorough cleaning after each calf is born. This is a very simple task with the James sanitary





pen but a very difficult one with pens of faulty construction. With the James pen the floor and the steel panels can easily be washed with a strong disinfectant.

Not only does the James cow pen meet every requirement in providing the maximum of ventilation, light and dryness, but it makes it very easy to keep the pen clean from day to day. The smooth surface of the steel offers little opportunity to collect dust and germs.

### James Tilting Feed Manger

The James Tilting Feed Manger for cow pens is a time and labor saver in feeding the cow, and is one of the most convenient devices about the barn.

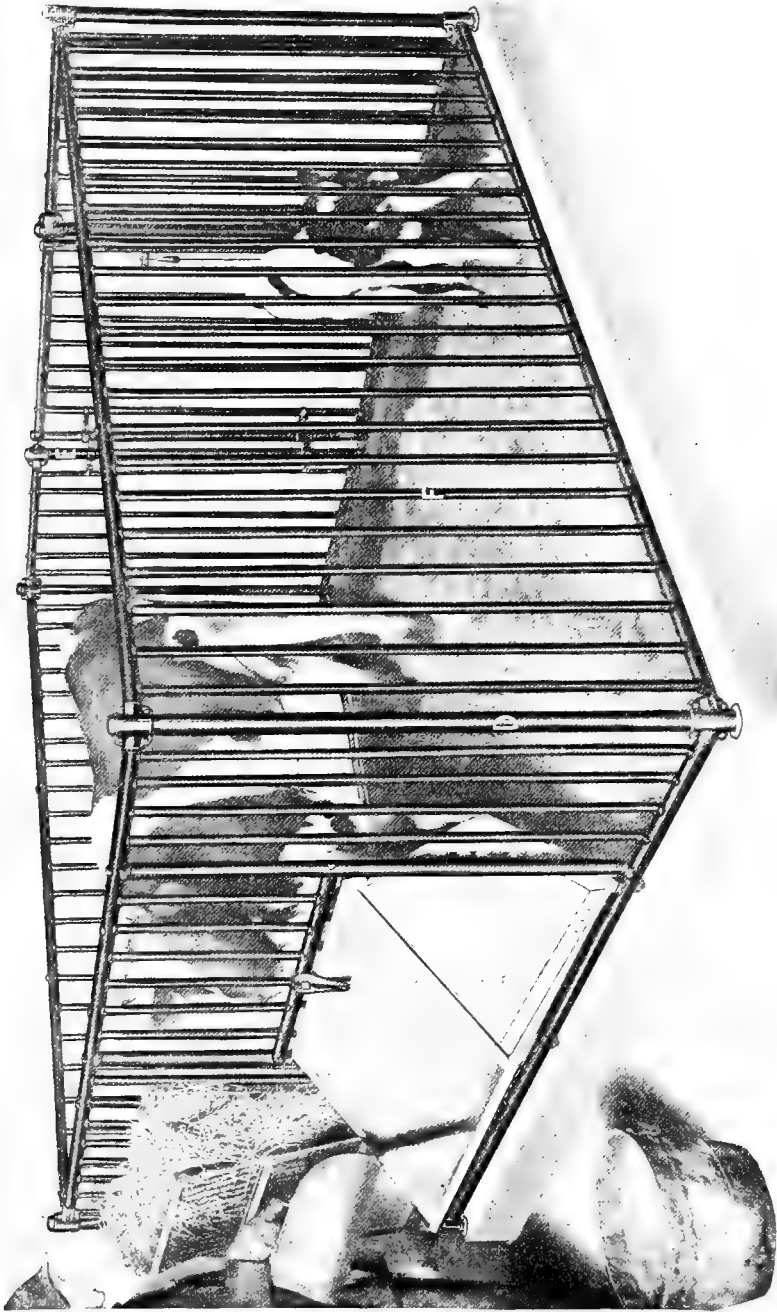
It is the only feed manger that solves the problem of feeding in the pen; making it possible to feed the animal without going inside.

Where an ordinary manger is used, the droppings of the cow are certain to fall into it, unless placed so high that it prevents her eating. If placed on the floor, or low enough for feeding, the box is certain to become fouled, to be tramped on, and to interfere with the cow's freedom.

The James Tilting Feed Manger is placed at a convenient height for the cow; it is inside the pen while she is eating, and may be outside the pen, out of her way the balance of the time. It then takes up no room inside the pen when not in use, giving the cow the full benefit of the space.

To feed, the manger is filled and tilted in, locking in position; when the cow is through eating, it may be tilted out. To clean, the manger is dropped to the floor outside the pen and quickly swept out or flushed.

The manger requires 3 feet 3 inches of the panel, and is 3 feet long; projects 20 inches into the pen, 21 inches into the alley when swung out for filling, and 25 inches into the alley when dropped to the floor for cleaning.



James Sanitary Cow Pen

# James Sanitary Cow Pen

(PATENT APPLIED FOR)

## SPECIFICATIONS

**CORNER POSTS:**  $1\frac{1}{8}$  in. O. D. pipe. Used with James Tubular Pen Anchors.

**GATE POSTS:**  $1\frac{1}{8}$  in. O. D. double strength pipe. Used with James Tubular Pen Anchors.

**INTERMEDIATE POSTS:**  $1\frac{5}{8}$  in. O. D. pipe. Used with James Tubular Pen Anchors. Used when panels are over nine feet.

**PANEL HORIZONTALS:**  $1\frac{5}{8}$  in. O. D. pipe. Top and bottom horizontals bolted together with  $\frac{7}{16}$  in. cut thread bolts, spaced not more than four spindles apart.

**PANEL SPINDLES:**  $1\frac{1}{16}$  in. O. D. pipe spaced  $5\frac{1}{4}$  in. on centers.

**ANCHORS:** James Tubular Pen Anchors  $3\frac{1}{2}$  in. O. D. 24-gauge steel, 9 in. long. Pen anchors are the only part of the pen required at the time the concrete work is done. (See page 192 for illustration.)

**FITTINGS:** Best malleable.  $\frac{7}{16}$  in. cut thread bolts used with fittings for attaching panels to posts.

**ORNAMENTS:** Best malleable; dust proof type.

**GATE:** Frame of  $1\frac{5}{8}$  in. O. D. pipe with  $1\frac{1}{16}$  in. O. D. steel pipe uprights. All fittings of best malleable. Equipped with same safety lock as on the bull pen. Hinges are of best malleable, offset so that gate swings back against pen. Half the hinge clamped not only to the gate post but also to the upright next to it; the other half of hinge clamped not only to the gate frame but also to the upright next to it.

**GATE LOCK:** Best malleable. Double latch, connected by  $\frac{3}{8}$  in. square steel rod. Gate locks when slammed shut; can be opened only by hand, it being necessary to raise the lever and turn. Can not be opened by the cow. Simple, positive in action, strong. (See page 194.)

**FINISH:** The steel is first mechanically cleaned, removing scale, grease and foreign matter, thoroughly preparing the material for painting; it is then finished with the best gray protective enamel, baked for two hours at a high temperature. (See page 129.)

**HEIGHT OF PEN:** 5 feet from floor.

 **WEIGHT:** 25 lbs. per linear foot.

SHIPPED ASSEMBLED IN PANELS

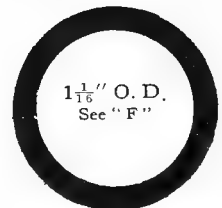
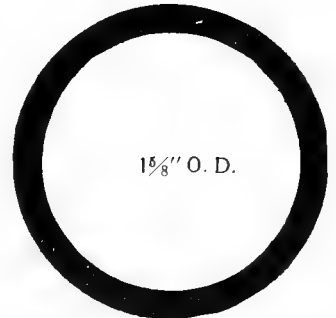
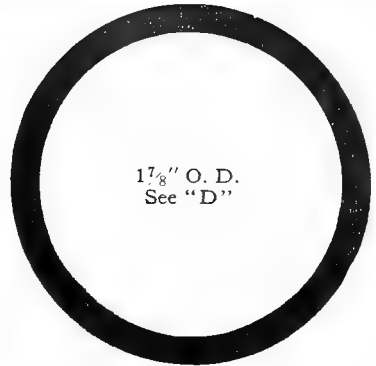
## James Cow Pen Tilting Manger

Made of heavy galvanized sheet steel, built on a framework of galvanized angle iron  $1\frac{1}{2}$  x  $1\frac{1}{2}$  x  $\frac{3}{8}$  in. and  $1\frac{3}{8}$  x  $\frac{7}{8}$  x  $\frac{1}{8}$  in. securely riveted. Upper edge of manger, inside of pen, reinforced with heavy wood bar, which prevents the cow injuring herself on the edge of manger. Hinges are of best malleable, the automatic lock is of best malleable.

## Stanchion for James Cow Pen

(PATENT APPLIED FOR)

Stanchion bars of  $1\frac{5}{8}$  in. O. D. pipe, with wood linings bolted on. Fittings are of best malleable. Neck space is adjustable from seven to fifteen inches. Stanchion lock is of safety type. Cannot be opened by cow. Locks when stanchion is closed; of best malleable.



Exact sizes of pipe used.



Young Stock Barn  
Lone Tree Farm.  
Green Lake, Wis.

## James Calf Pens

You have often noticed that the best producers in your herd are the most sensitive and are high strung animals. The calves from which these cows developed were more delicate and sensitive than the scrub calves.

If you stunt a calf, it can never develop into as profitable a cow as it should have done with good and thrifty natural growth. The first year of a cow's life will either make or ruin her as a high-grade producer.

The old wooden calf pen is apt to be the dirtiest place in the barn.

If the calf is to develop to the best advantage you must keep it in a clean, dry, comfortable place with plenty of light and fresh air.

The James sanitary steel calf pens make it possible to give the little animals the start in life which they should have.

At the same time the work of caring for the calves is lessened and the saving of labor alone pays big dividends on the investment.

The calves can be fed easily and more quickly in a James pen. We build adjustable calf stanchions into the front panel; at feeding time the calves are run into the stanchions which are then closed.

The James pen with its easily cleaned mangers or with the "Anti-sucking" guards enable you to feed each calf just the amount it should have; the fast eating and fast drinking calf cannot rob the others.

The James stanchions and complete mangers or Anti-sucking Guards make it easy to break calves of sucking one another. The sucking habit seems to be caused by the milk taste in the mouth of the calf giving him the desire to suck until this taste is removed.

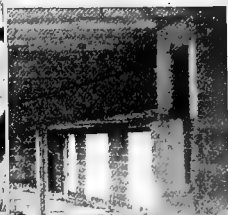
By confining the calves in the stanchions while they are being fed milk, they may be given dry feed after they are through drinking, to take away the milk taste. Within ten or fifteen minutes the calves will have forgotten their desire to suck and in a few days will lose the habit entirely.

Now here is the proposition. Every cow that you raise for the next ten or fifteen years, at least, will probably be started in the calf pen. In this time you may raise from 75 to 100 or 150 calves. The first cost of this pen is the only cost and, therefore, the money you put in it now, you can figure on dividing equally among the number of calves you will raise in that time. The cost per calf is very little.

The calf, like any other baby, is very sensitive, requiring the proper care and surroundings, as well as suitable food, if it is to thrive and grow into a vigorous animal.



James Sanitary Steel Calf Pens With Complete Mangers and Guards



The calf is the foundation of the future herd. Stunt the calf and it can never develop into the profitable cow which good care and thrifty growth would have produced.

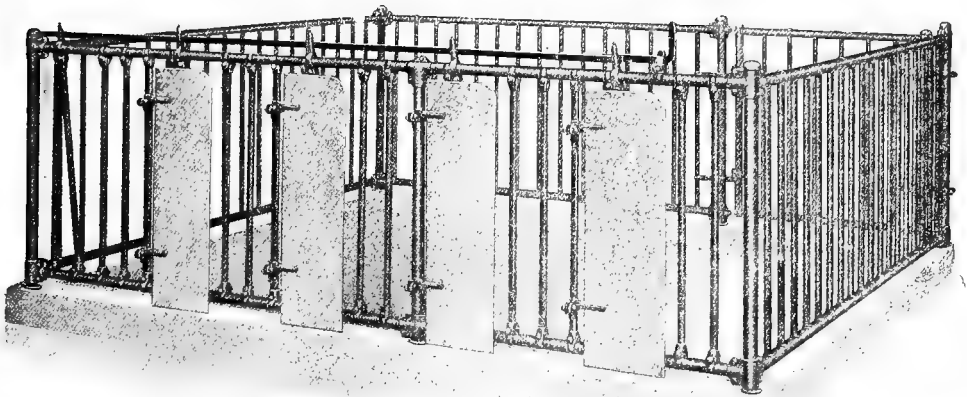
You take pains to build up your herd and breed quality into your calves. Is it not wise, therefore, to spend perhaps 50c or \$1 on each calf providing it with the proper quarters, as insurance against its sickness, against its being stunted, and to make sure of better cows?

In connection with the stanchions on the calf pen, we can furnish the complete manger with head guard, it being easy to thoroughly clean the cement trough by raising the mangers; or the "Anti-sucking" guards which prevent one calf from reaching over and tormenting the one next to it.

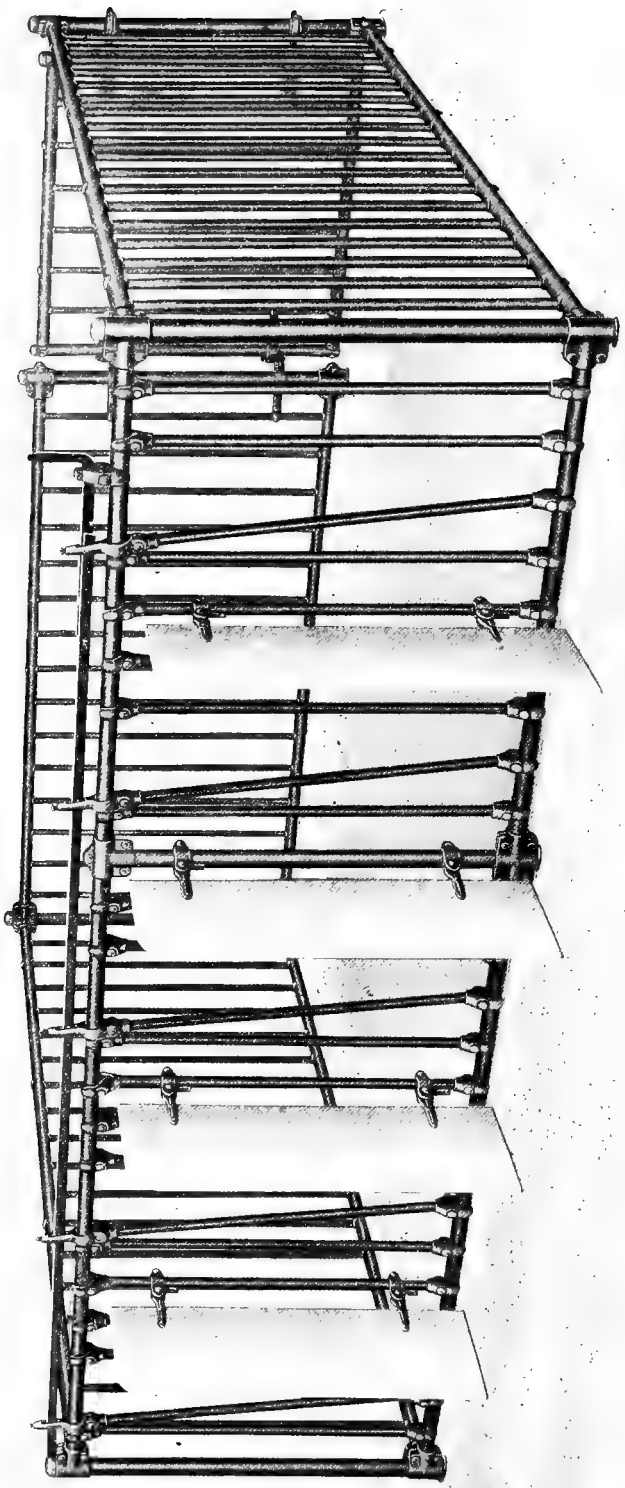
The "Anti-sucking" guards may be easily swung to the side, back against the stanchion, when you wish to clean out the cement trough in front of the stanchion; or may be removed entirely; when in use to separate the calves it is held rigidly.

There are no sharp fittings on the pen against which the calves can injure themselves. For the first few weeks of its life the calf's skull is soft and a sharp blow against it will greatly injure and sometimes kill the little animal. There are a great many cases where valuable high-bred calves have been killed in this way and in purchasing a pen this is a point to be looked for.

All the stanchions are adjustable in neck space, accommodating the calves as they grow. The stanchions may be controlled by a single lever, opening or closing them all at the same time; or they may be opened or closed one at a time.



James Calf Pen with "Anti-Sucking" Guards  
(PATENTED)



James Sanitary Calf Pen with "Anti-Sucking" Guards  
(PATENTED)



# James Sanitary Calf Pen

(PATENTED)

## SPECIFICATIONS

**CORNER POSTS:**  $1\frac{1}{8}$  in. O. D. pipe. Used with James Tubular Pen Anchors.

**GATE POSTS:**  $1\frac{7}{8}$  in. O. D. double strength pipe. Used with James Tubular Pen Anchors.

**INTERMEDIATE POSTS:**  $1\frac{5}{8}$  in. O. D. pipe. Used with James Tubular Pen Anchors.

**PANEL HORIZONTALS:**  $1\frac{5}{8}$  in. O. D. pipe. Top and bottom horizontals bolted together with  $\frac{7}{16}$  inch cut thread bolts, spaced not more than four spindles apart.

**PANEL SPINDLES:**  $1\frac{1}{16}$  inch O. D. pipe spaced approximately  $5\frac{1}{4}$  inches on centers.

**ANCHORS:** James Tubular Pen Anchors  $3\frac{1}{2}$  in. O. D. pipe, 9 in. long. Made of 24-gauge steel. Pen Anchors are the only part of the pen required at the time the concrete work is done. (See page 192.)

**FITTINGS:** Best annealed malleable.  $\frac{7}{16}$  in. cut thread bolts used with fittings for attaching panels to posts.

**ORNAMENTS:** Best malleable; dust-proof type.

**GATE:** Frame of  $1\frac{5}{8}$  in. O. D. pipe with  $1\frac{1}{16}$  in. O. D. pipe uprights. All fittings of best malleable. Equipped with safety lock as on the bull pen. Hinges are offset so that gate swings back against pen; of best malleable, half the hinge clamped not only to the gate post but also to the upright next to it; the other half of hinge clamped not only to the gate frame but also to the upright next to it.

**GATE LOCK:** Best malleable. Double latch, connected by  $\frac{3}{8}$  in. square steel rod. Gate locks when slammed shut; can be opened only by hand, it being necessary to raise the lever and turn. Can not be opened by the animal. Simple, positive in action, strong. (See page 194.)

**FINISH:** The steel is first mechanically cleaned, removing scale, grease and foreign matter, thoroughly preparing the material for painting. It is then finished with the best gray protective enamel, baked for two hours at a high temperature. (See page 129.)

**HEIGHT:** With 6-in. curb, pen is 3 feet 10 inches from the floor.

**WEIGHT:** 22 lbs. per linear foot.

SHIPPED ASSEMBLED IN PANELS

## James Calf Stanchions

(PATENTED)

James Calf Pen Panels will be fitted with James Calf Stanchions at a slight additional cost. James Calf Stanchions are adjustable in neck space; may be opened and closed one at a time or all together. Made of  $1\frac{1}{8}$  in. O. D. pipe; fittings of best malleable; all stanchions connected with bar steel lever.

We recommend allowing 24 inches on centers for each calf; and not less than 20 inches.

## Calf Pen Mangers

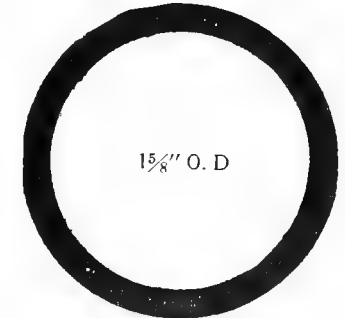
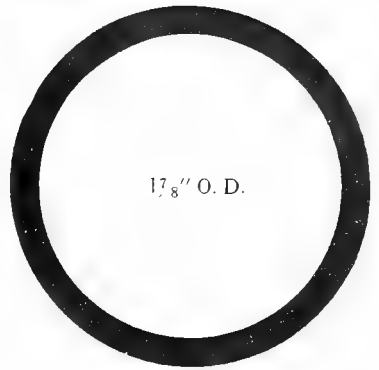
(PATENTED)

Constructed the same as the James Complete Mangers for cow stalls, described on page 137, excepting that James Calf Pen Mangers are made with flat bottom, and without manger lifting springs. (See page 206 for illustration.) Calf Pen Mangers project 28 inches from the panel and are  $20\frac{1}{2}$  inches deep.

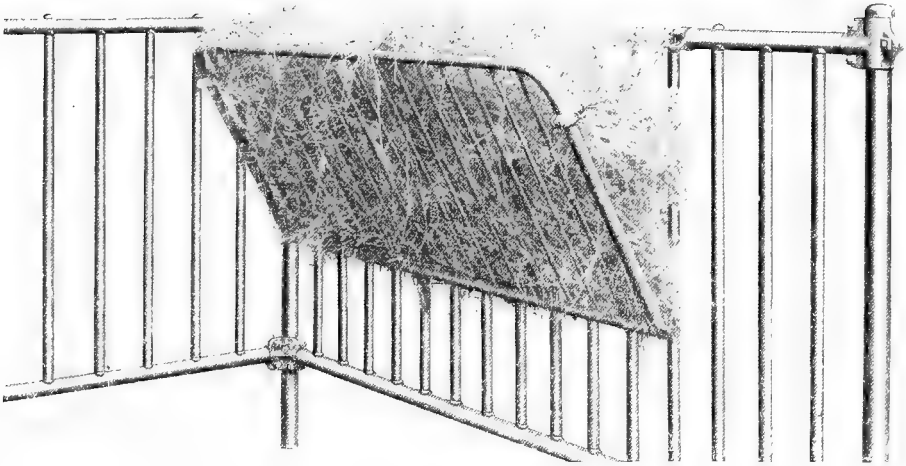
## “Anti-Sucking” Guards

(PATENTED)

Made of 14-gauge galvanized steel,  $10\frac{7}{8}$  in. x 36 in. Fittings of best malleable, so constructed as to reinforce the guard. Guards held rigidly in place by the fittings, but easily lifted and swung back against panel.



Exact sizes of pipe used,



## Calf Pen Hay Racks

The James Rack is the most convenient device for feeding hay, in connection with calf pens.

The frame is of  $1\frac{1}{16}$ -in. O. D. pipe, with spindles of  $\frac{1}{16}$ -in. round steel, spaced about  $3\frac{1}{2}$  in. on centers.

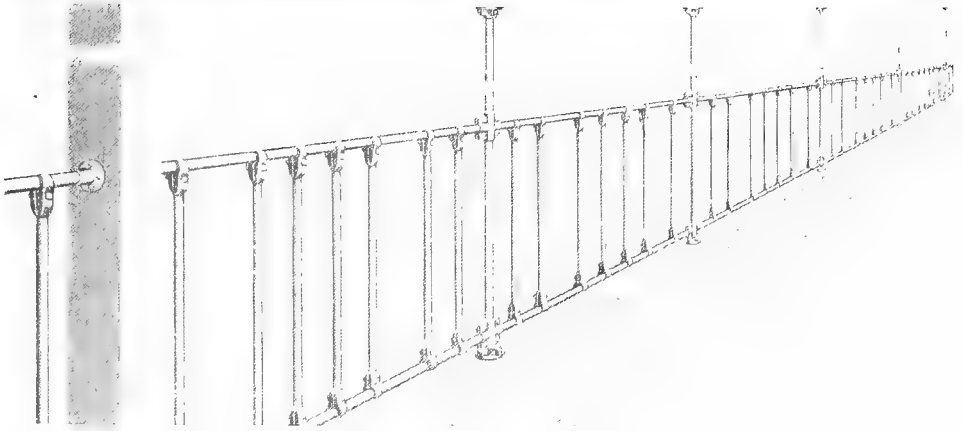
The racks are made in three sizes:  $24\frac{1}{2}$  in. x 4 ft., 6 ft. and 8 ft. respectively.



## James Pail Holder

The James Pail Holder simplifies the task of feeding calves by holding the pail firmly to the calf stanchions.

The holder consists of adjustable steel bands hinged to the calf stanchion spindles.



## Fat Stock Feeding Panel

Horizontals, spindles and intermediate posts all of 1 7/8-in. O. D. pipe, furnished with fittings to attach to pen posts, wood posts, or steel columns as desired. Spindles attach to horizontals with malleable clamps so that size of opening is adjustable. Intermediate posts attach to stall post anchors as illustrated on page 122 so that panel may be removed and replaced as desired.



## Young Stock Panel

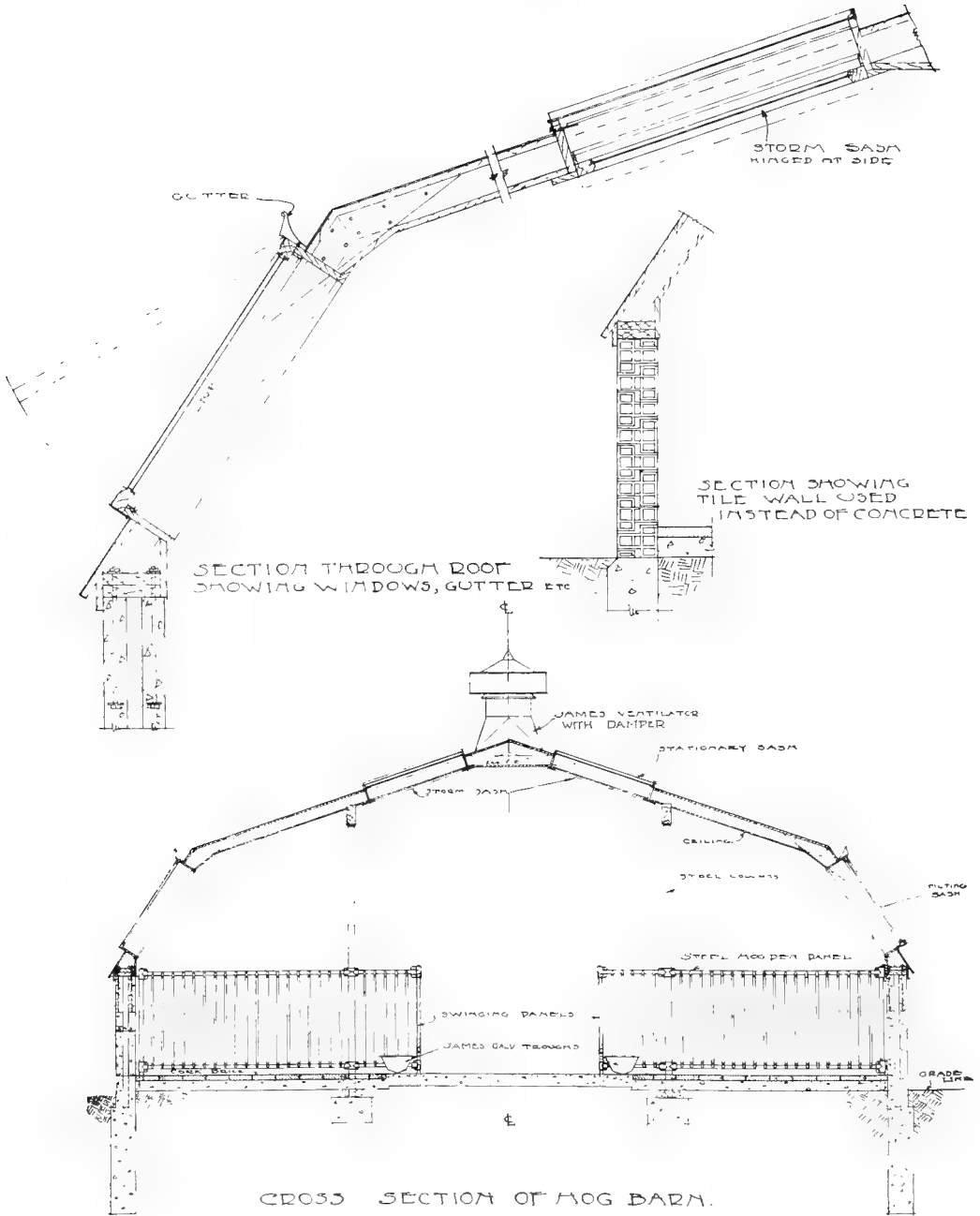
(Patented)

**WITH STANCHIONS:** The horizontals, intermediate posts and stanchions are of 1 5/8-in. O. D. pipe, spindles 1 1/4-in. O. D. pipe. Fittings best malleable with cut thread bolts. The stanchions, adjustable in width of neck space, may be opened and closed one at a time or all together. Stanchions spaced not closer than 2 ft. 4 in. on centers.

Intermediate posts attach to stall post anchors as illustrated on page 122; panel may be removed and replaced as desired.

**WITHOUT STANCHIONS:** Same as above excepting that opening and closing bar is not furnished and stanchions do not open and close; instead opening (adjustable, however, in width) is furnished similar to opening in fat stock feeding panel shown above.

Stanchions should not be spaced closer than 2 ft. 4 in. on centers.



SECTION THROUGH ROOF SHOWING WINDOWS, GUTTER ETC

SECTION SHOWING TILE WALL USED INSTEAD OF CONCRETE

JAMES VENTILATOR WITH DAMPER

STATIONARY SASH

STORM SASH

CEILING

STEEL COLUMNS

FILTER SASH

STEEL WOODEN PANEL

SWINGING PANEL

JAMES GALV TROUGH

GRADE LINE

CROSS SECTION OF MOGG BARN.

PATENT APPLIED FOR

# The James Sanitary Hog Pen



THE early hog is, of course, the profitable hog. If it is possible to send a bunch of pigs to the market a month earlier than you would ordinarily send them, that bunch of pigs is proving a big money maker; but the early pig is not saved without warm, dry and sanitary quarters. It is necessary to properly house pigs for winter farrowing if you expect to prepare them for early pasturage and early market.

To provide such quarters, the James Manufacturing Co. presents a new type of hog barn construction. The new construction has met with the approval of every hog raiser who has inspected it.

This new James Gambrel roof barn is superior to any other type of hog barn construction, in that it permits a greater amount of sunlight. By facing the barn Northwest and Southeast, it is possible to have sunlight on the floor throughout the day.

The saw-tooth hog barn which has been advocated in the past, and with which you are familiar, will admit the sun only five or six hours of the day. Hog men who have used the saw-tooth barn, in a good many cases condemn it because it is too cold, owing to the great height between the floor and the apex. This height, if the saw-tooth barn is properly proportioned, is 14 ft.; the greatest height between the ceiling and floor in our new barn is 10 ft.; thus the barn is warm and comfortable, which is even more important than sunlight in a farrowing building.

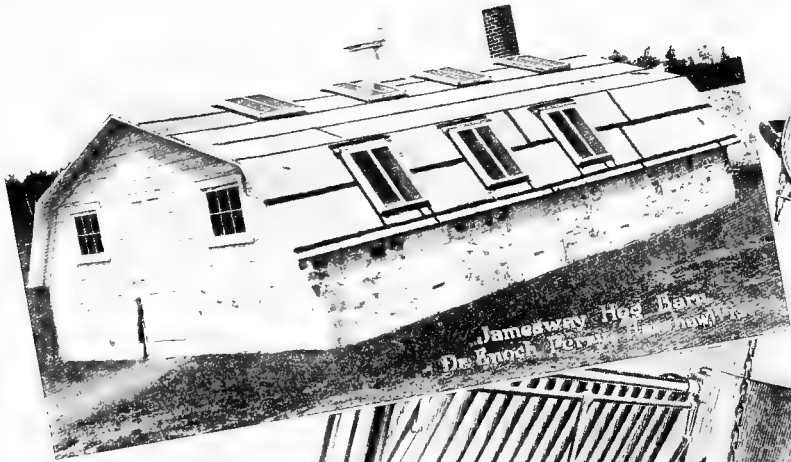
The two windows in the first pitch can be tilted, if desired, allowing a flow of air to pass through the building. The windows are high enough so the draft will be above, and not directly onto the animals. The two upper sash should be stationary as it would be unnecessary to open them at any time. We furnish detailed drawings showing how the sash should be built.

The cheapest and best material to use for the walls is hollow tile, although a monolithic cement wall with an air space will prove entirely satisfactory.

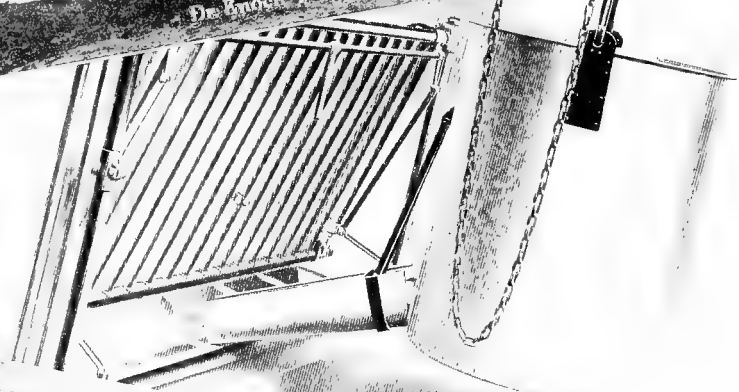
The roof is, of course, of ordinary frame construction. It should be covered with a composition roofing. This would prove more economical than shingle and it is easier to handle around the built-in windows.

There are varied opinions as to the material best suited for the floor. Our experience has been that a cement floor with a cork brick or creosoted block nesting place is the more satisfactory. Some hog breeders have recently adopted a combination hollow tile and cement floor which is proving highly satisfactory. The floor is laid of hollow tile, in 2-in. covering of concrete, the air space in the tile keeping the floor warm and comfortable.

The cost of the new type of hog barn is a little higher than the cost of the saw-tooth barn, but the additional cost is much more than offset by the greater benefits.



Jamesway Hog Barn  
The Knock Port



## The James Sanitary Hog Pen

The James Sanitary Steel Hog Pen helps prevent disease because of the cleanliness made possible through its use; it aids the little pigs in their development by affording light and ventilation; making them marketable at the earliest possible date; cuts down labor bills, both in feeding the pigs and in cleaning the barn; it is permanent, the first cost being the only cost. It is pleasing in appearance and a source of lifetime satisfaction to the purchaser.

The biggest advantage in the James steel hog pen is that it permits of sanitary conditions in the barn. There is but one way in which the hog cholera germs, for example, can be done away with and that is by maintaining a clean hog house. James pens permit plenty of sunlight and fresh air to enter. The pens can be much more easily and effectively fumigated than wood and this is a big item to be taken into consideration especially among those hog raisers who disinfect their barns almost daily.

James steel hog pens can be more easily and quickly cleaned than wood pens; they are always drier than the wooden pens because the sunlight has access to every square foot of floor space, and because the steel pen interferes least with proper circulation of air.

It is a noticeable fact that in a steel equipped hog barn the hogs seem much more contented than ordinarily because of their ability to see about. It is also possible for the attendant to see into every pen from any part of the barn.

James hog pens are constructed throughout of pipe, thoroughly cleaned and finished in enamel baked on, the same as other James equipment.

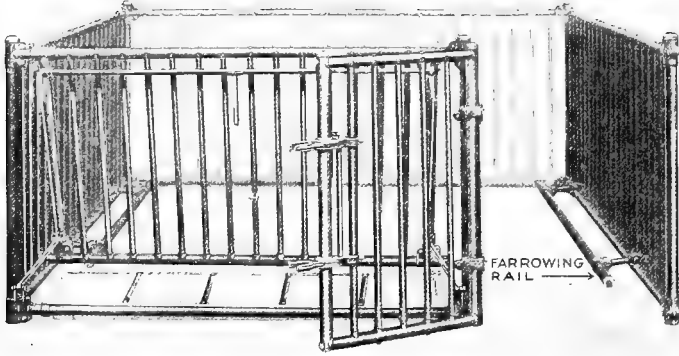
The hog pens are shipped assembled in panels. To erect the pens it is necessary only to set the corner and gate posts in the tubular anchors (which will have previously been set in the concrete), bolt on the panels, and pour in cement around the gate and corner posts; when this cement is set the pen will be solid.

The great amount of labor saved in the erection by using James assembled panels, is a big item. Figure the labor required to build a wooden pen and you will find that it goes a long ways towards paying for the steel pen.

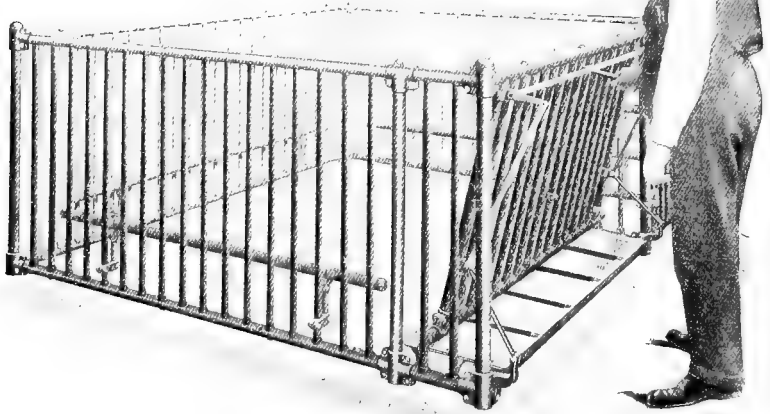
James steel pens are exceedingly durable, the first cost being the only cost, whereas wooden pens rot out in time necessitating the replacing of the entire outfit, and in the end costing more than the steel.

Where the James steel pens are used the dividing panels can be swung up, out of the way, throwing two or three pens into one for feeding purposes.

James hog pens are built any size required. The average farrowing pen should be 8 ft. 6 in. x 9 ft. 6 in. The size of the pens, of course, will vary with the personal preference of the purchaser, but the above size is looked upon as standard.



James  
Sanitary  
Hog  
Pens





The nesting place should be about 5 ft. 6 in. x 7 ft. in a standard pen. Either cork brick or plank should be used for the nest. Usually the nest is about 2 inches higher than the main floor. Some seem to think that the sow will not always take the nest, but this is the case only when the attendant has been careless in bedding. If the nest only is bedded, the sow will lie there.

It is advisable to slant the pen floor towards the wall using a shallow gutter next to the wall for drainage purposes.

### The Farrowing Rail

Too much stress cannot be placed upon the importance of the farrowing rail. When the sow lies down, the farrowing rail will prevent her from crushing the little pigs against the wall; they will simply be shoved under this rail and be protected in the space between the rail and the panel, and then run around to the front side of the mother.

The farrowing rail should be 8 in. above the floor and the same distance from the panel, and should extend around three sides of the pen.

The James farrowing rail may be swung up out of the way after the little pigs are able to take care of themselves, and the farrowing rail is no longer needed. Lifting the farrowing rail transforms the pen into a feeding pen.

### The Swinging Panels

The swinging front panel will appeal to every man who has ever taken an active part in hog feeding. It does away with any need of straddling the fence, kicking the old sow in the ribs, at the same time trying to keep a dozen or so little pigs away from the trough while attempting to pour in the liquids.

An ingenious device makes it possible to swing the panel, by means of a lever at front of pen. See illustrations. Front panel is equipped with latch for holding trough up out of the way when not in use; when in this position trough drains itself and will be kept free from dirt. Easily flushed clean with water.

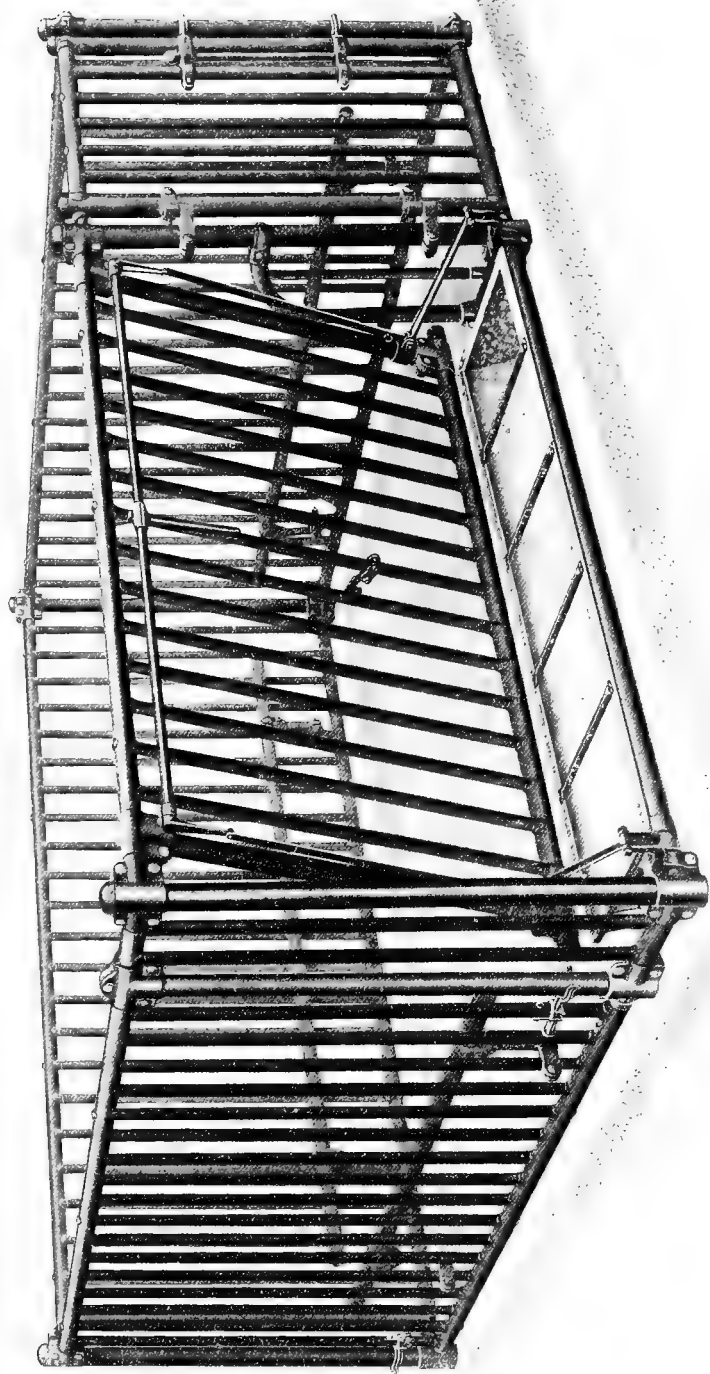
Panels between pens may at slight additional cost, be so constructed that they may be brought up and locked out of the way thus turning two or more hog pens into one larger pen.

### Tilting Trough

The trough is of a peculiar design, which prevents trouble from liquids in the trough freezing; on account of the sloping sides, the contents rise as it freezes. The shape of the trough allows the pigs to get all the contents; at the same time, trough will drain easily. When trough is tilted it gives the hog that much more room in the pen, and makes it easier to clean the floor.

Like all James goods, the hog trough is of unusually strong construction, and should last as long as the pen.

This new swinging panel, together with the James farrowing rail and tilting feed trough, are the biggest improvements ever made on a hog pen.



Where no curb is used between pens, intermediate panels will be furnished, at additional cost, with spindles 3 in. longer.

**James Sanitary Hog Pen**  
(PATENT APPLIED FOR)

# James Sanitary Hog Pen

(Patent Applied For)

## SPECIFICATIONS

**CORNER POSTS:**  $1\frac{1}{2}$  in. O. D. pipe. Used with James Tubular Pen Anchors.

**GATE POSTS:**  $1\frac{1}{2}$  in. O. D. double strength pipe. Used with James Tubular Pen Anchors.

**INTERMEDIATE POSTS:**  $1\frac{1}{2}$  in. O. D. pipe. Used with James Tubular Pen Anchors.

**PANEL HORIZONTALS:**  $1\frac{1}{2}$  in. O. D. pipe. Top and bottom horizontals bolted together with  $\frac{7}{16}$  in. cut thread bolts, spaced not more than four spindles apart.

**PANEL SPINDLES:**  $1\frac{1}{16}$  in. O. D. pipe spaced 4 inches on centers.

**ANCHORS:** James Tubular Pen Anchors  $3\frac{1}{2}$  in. O. D. pipe, 9 in. long. Made of 24-gauge steel. Pen anchors are the only part of the pen required at the time the concrete work is done. (See page 192 for illustration.)

**FITTINGS:** Best annealed malleable.  $\frac{7}{16}$  in. cut thread bolts used with fittings for attaching panels to posts.

**ORNAMENTS:** Best malleable dust proof type.

**GATE:** Frame of  $1\frac{1}{2}$  in. O. D. pipe with  $1\frac{1}{16}$  in. O. D. pipe uprights. All fittings of best malleable. Equipped with double latch and safety lock. Hinges are offset so that gate swings back against pen; of best malleable, half the hinge clamped not only to the gate post but also to the upright next to it; the other half of hinge clamped not only to the gate frame but also to the upright next to it.

**FINISH:** The steel is first mechanically cleaned, removing scale, grease and foreign matter, thoroughly preparing the material for painting; it is then finished with the best gray protective enamel, baked for two hours at a high temperature. (See page 129.)

**HEIGHT:** With 4 in. curb, pen is 3 feet 8 inches from the floor

**WEIGHT:** 25 lbs. per linear foot.

SHIPPED ASSEMBLED IN PANELS

## Swinging Panels

(Patent Applied For)

**FRONT PANEL:** Horizontals of  $1\frac{1}{2}$  in. O. D. pipe, uprights  $1\frac{1}{16}$  in. O. D. pipe. Hinge and all fittings malleable with cut thread bolts. Swinging mechanism best malleable and bar steel.

**PIG STOP:** Of  $1\frac{1}{2}$  in. and  $1\frac{1}{16}$  in. O. D. pipe, best malleable fittings and cut thread bolts

**DIVIDING PANEL:** Panels dividing pens are so constructed that when desired, they may be swung up and locked out of the way, thus turning two or more pens into one larger pen.

## Farrowing Rail

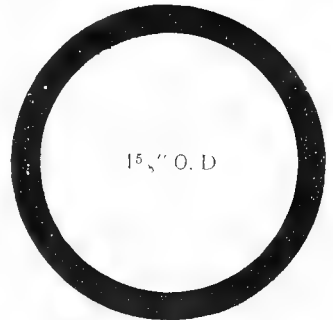
(Patented)

Made of  $1\frac{1}{2}$  in. O. D. pipe; hinge and rail brace of best malleable

## Tilting Feed Trough

(Patent Applied For)

Trough is of 18-gauge galvanized sheet steel; ends are locked seamed with reinforcing plates on corners; angle iron dividers across the trough at intervals of 12 inches, riveted to the galvanized sheets. Furnished with device for holding trough down; and with device for holding trough raised.



Exact sizes of pipe used



*Barn of Col. K.O. Lowden  
Oregon, Ill.  
Equipped the James Way*

# The James Carriers



HERE the manure is loaded on to the spreader and put on the fields at once, the James Carrier makes it possible to get the manure on to the soil with *but the one handling*—that of loading the tub in the barn.

That's some different, isn't it, from loading the manure into a wheelbarrow—pushing it out through the barn, leaving a trail of dripping filth—across a mushy yard and up on to a manure pile, trying the strength and patience of the strongest man; afterwards loading the wagon from the pile, losing the liquids; then hauling it to the field, dumping in piles and later scattering with a fork.

The big tub of the James Carrier holds as much as three or four wheelbarrow loads; the carrier can be run out and dumped in less time than a single wheelbarrow and it takes no longer to load manure into the carrier than it does into the wheelbarrow. The saving of time and work is very large.

The James Manure Carrier not only saves much of the hard work, but it saves you many dollars' worth of liquid manure which could not be saved in any other way; the saving of liquid manure alone will go a long ways towards paying for the carrier.

When the wheelbarrow method is used, the manure is quite apt to be piled near the barn. But with the James Carrier, it is easy to put the pile far away from the stable, so that there will be no fumes of ammonia arising near the building to damage the paint, rot the sides and sills, ruin the finish of vehicles near by, injure the health of the animals, or taint the milk. You can keep a clear space between the barn and the pile or manure shed.

The James Feed Carrier or the James Feed Truck will save you so much walking back and forth to the feed room, and will save you so much work and time, that you will wonder how you ever got along without it.

You can feed twenty-four cows or more the James way, with no more walking and in the time required to feed a few by the basket method.

Your feed basket holds enough silage for only one or two cows; the James Carrier or James Feed Truck holds sufficient for twenty-four to twenty-eight. And the James way is easier, because you have no weight to carry—the silage being loaded into the tub at the silo or in the feed room, and rolled easily along in front of the mangers. The James Milk Can Carrier and Harness Carriers are also time and labor savers.

## SAVES 30 MILE WALK EACH WINTER

Paulson Bros., Independence, Wisconsin: "We are more than pleased, with the outfit, as it actually cuts the chores in half. In the first place the feed truck saves us eight trips the length of our 100 foot barn, over carrying silage in baskets. And the litter carrier, every trip you make with it saves two extra trips with the wheelbarrow."

"The cows can do better as one can keep it more sanitary for them. The swinging stanchions keep them comfortable. Besides, the modern steel fixtures make the barn lighter.

"To sum it up, why a man can put on his best Sunday clothes go to the barn and do the chores without being "mussed" up. And last but not least, you don't have to invite the cows a second time to come in, as we know some cows will attempt to jump over the doors if we don't open soon enough to suit them."



All the James Carriers are more nearly indispensable than any hay carrier, for these carriers save work each day throughout the whole year. We claim for all James Carriers that with them you can do the work for which they are intended more quickly, more easily, and at less daily cost, than you can in any other way. And if they don't make good, you can get your money back.

The James Carriers have many important and distinctive features, not only in the carrier itself, but in the track, hangers, switches, removable track section and swinging steel crane.

All the objections to the ordinary carriers are completely overcome; and in addition the James Carriers possess added improvements never before utilized in carrier equipment.

They are not an experiment. The men who originated them and brought them to their present state of perfection know from experience just what is required of a carrier, for they have been practical, successful dairy farmers themselves, and have used, or seen in use, probably every carrier on the market.

James Carriers are the result of long years of observation of the various types in actual use in barns, where the strong points and the weak features have been shown up by the wear and strain of daily use.

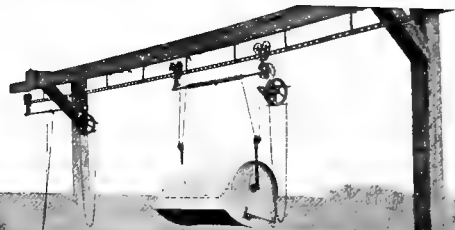
The strong points have been retained and new features added, making them the most practical, most serviceable and most satisfactory of all.

A litter carrier has heavy work to do. Not only must it oftentimes carry half a ton of manure, but it is in daily use throughout much of the year. Slammed about by careless help, or in the hurry of cleaning up the chores, some part will give way unless it be exceptionally strong and well made.

James Litter Carriers are more strongly and heavily built than any other on the market, every part is heavy enough to carry three times the load to which it will ever be subjected as a manure carrier. The track and hangers, the safety switches, the removable sections, and the swinging crane all have several times the strength necessary to support the carrier when most heavily loaded. No amount of ordinary rough usage will cause a breakdown.

James Carriers are much heavier than others for which you would have to pay the same price; the extra weight of malleables and steel alone costs us several dollars more on a carrier, to say nothing of the better workmanship and superior finish. Yet we offer them to you for the same price that you would have to pay for the lighter weight and more poorly constructed outfit.

This extra weight means heavier malleables, a stronger angle iron framework throughout the tub, steel plate reinforcement on the ends, a solid, cold rolled, steel shaft—in fact greater strength at every point where strain or wear may come. It insures durability, a saving of repairs, and makes certain satisfactory service for a long period of years.





The Simplicity of the entire James Carrier outfit also makes for greater strength and durability, the extra weight of material being only at those points where strength is needed; and there are no complicated parts to wear.

In the following pages we have described the carrier in detail, and we want you to note that in each case we have stated the exact weight and given complete specifications, so that you may compare for yourself our carriers and those offered you by others at equal or higher prices.

The photographs and descriptions show why it is that James Carriers are more easily erected and more easily operated than any others; why they run more smoothly on the track; how they meet every condition ever required of a carrier in the barn; why the I-Beam track is more suitable in every way for curves, switches and outside work; how the automatic safety stop blocks make it impossible for a carrier to run off the track; and how the simple construction eliminates worm gearings, ratchets and cogs that are so liable to wear or break.

And as you study the carrier proposition, we ask that you bear in mind that while there may be carrier outfits offered you at lower prices, the James Carriers are so built as to cost you by far the *least per year*—and that is the only fair way in which to figure the cost of any article.

James Carriers are “long life” carriers—built to stand the strain and wear of years—made to forestall breakages and repairs—made to save the maximum of work and time. We are proud of them, believing that each is the best that can be built to meet the specific purposes for which it is designed. And in this belief, we are backed up by the hundreds of enthusiastic, commendatory letters received from owners of James Carrier outfits.

Of all the litter carriers, the one that has the largest sale, and hence apparently best meets the requirements of the average dairyman, is the “Big Boy” Carrier; and this is the outfit which we would recommend for the barn in which fifteen head of stock or more are being cared for.

The Combination outfit fills the need in small barns, where the rigid I-Beam track is wanted inside, with a rod track outside—so as to have the advantage of the automatic return secured only by use of the rod track. With fifteen head of stock or more, however, the “Big Boy” with the swinging steel crane or outside arch support is recommended, for the reason that in the long run it will prove more satisfactory and more economical.

The “Chore Boy” is recommended only for the smallest barns, where but a few head of stock are cared for.

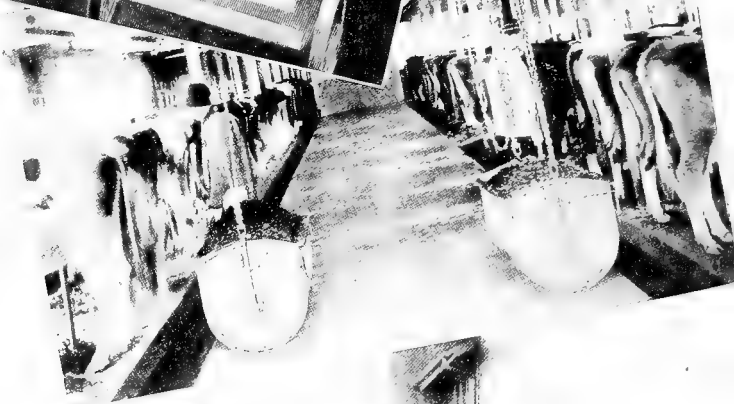
#### SAVES HALF THE TIME

Eau Clair · Wis., December 15, 1917.

In reply to your letter in regards to the carrier and swinging crane will say that we used to use wheelbarrows in cleaning our Barn.

We have fifty head of cattle in our cow barn and I think I am safe in saying that 50% of time is saved in cleaning the barn over the old way.

EAU CLAIRE COUNTY INSANE ASYLUM,  
S. E. HOREL, Supt



Shelby, Wis. Equipped the James Struck



BARN OF ALBERT DEAN - BOSTON, MASS.

Wilton, Wis., Nov. 18, 1918.

I have had the James Barn Equipment installed this summer and must say it sure is a first-class equipment. I cannot say enough for the James litter carrier. I would not have it taken out of my barn for \$500, if I could not get another one to put in.

F. A. WAEGE,  
Wilton, Wis.

Bark River, Mich., Jan. 7, 1918.

I received your letter some time ago relating to our litter carrier asking what improvement it was over a wheelbarrow.

I can say that a 12-year-old boy can clean the barn with the carrier in one-half the time it would take a grown man with a wheelbarrow.

WM. A. GOOD.

Lake Linden, Mich., Jan. 17, 1918.

I am using a James carrier outfit in my barn, and find that it saves one-third the time each day as compared with the old way of cleaning out the barn. I have 16 cows and used to back the spreader into the stable.

J. R. FRANKS.

Okauchee, Wis., January 2, 1918.

I used to clean my barn with a wheelbarrow.

I have 16 cows and 2 pens, and I can clean them in less than one-half the time with the carrier, as I could with the wheelbarrow and very much easier.

H. S. ERICKSON.

Gainesville, N. Y., Jan. 18, 1918.

I handed your letter to my tenant for reply and he says:

"In regard to the litter carrier we find it the most handy thing in the barn. We have 23 head of cattle and can clean out in half the time. It is a good deal easier than with a wheelbarrow."

H. J. SHEARING,  
L. S. DUGGAN.

Fond du Lac, Wis., December 13, 1917.

Answering your inquiry of recent date, we have been using litter carrier and swinging crane for the past six weeks, with very satisfactory results. At least one half of the labor can be saved and considerable time also by having these devices. In our old barn all the manure had to go out through one door carried on a fork and as a result the walk back of the cows was always covered with more or less filth. Now our barn is sanitary all the time. We are more than pleased with our equipment.

K. S. SMITH.

Winthrop, N. Y., Nov. 18, 1917.

In regard to the manure carrier as a labor saver, I would say it will save one half of the time used in any other method of cleaning a stable. I have used a wheelbarrow and the best I could do was forty minutes, and with carrier twenty minutes will do the job and do it easy.

Number of cows thirty.

FRED ADAMS.

Galien, Mich., Nov. 9, 1917.

My barn is one hundred feet long and floor is on two levels. We keep 17 cows and some young stock. The carrier outfit saves us an hour each day over the old wheelbarrow way.

F. D. NOGGLE.

Dallas, Wis., Dec. 26, 1917.

Have been using your big boy manure carrier and a 40 ft. swinging crane for one year and can now let you know what I think of it. I can recommend it as both time and labor saver. I used to wheel the manure out in a wheelbarrow and now I don't know how we got along without the carrier as my 12-year-old boy can clean the barn in one-half the length of time that it is used to take me and do it easier.

I. H. BALAND,  
Dallas, Wis.

December 19, 1917.

I received your letter and want to answer how I like my litter carrier. I like it fine and would not like to be without it any more. I think it is a great help in cleaning stables. I used to use a wheelbarrow. I think it is a great labor saver, as a little boy can clean out stables now where he could not with a wheelbarrow.

I am well satisfied with it.

D. J. GLICK,  
Shipshewana, Ind.

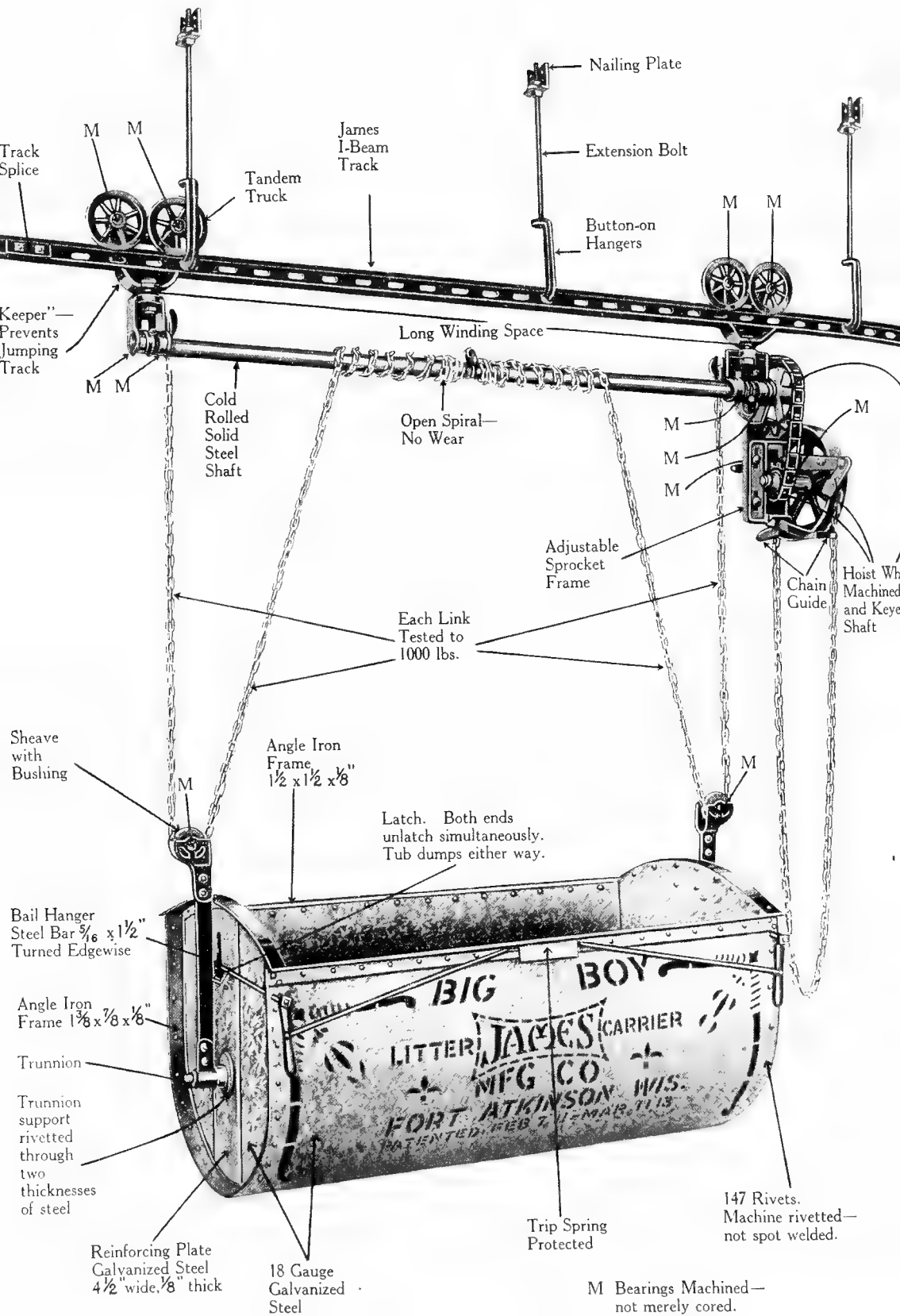
Leechburg, Pa., Nov. 14, 1917.

The Litter Carrier I am safe in saying saves half the work.

Cleaned before with wheelbarrow. Dumped manure in a shed most of the time.

I have at the present time 14 head of cows and 9 head of young cattle, about 14 head more than I will have a month from now unless feed comes down in price or milk goes up. Am getting 30c per gal. delivered about 4 miles from here. Will say on the whole that I can care for two cows easier than I did one before.

R. M. ARTMAN.



Track Splice

M M

Tandem Truck

James I-Beam Track

Nailing Plate

Extension Bolt

Button-on Hangers

M M

Keeper—Prevents Jumping Track

Long Winding Space

M M

Cold Rolled Solid Steel Shaft

Open Spiral—No Wear

M M M

Adjustable Sprocket Frame

Each Link Tested to 1000 lbs.

Hoist Wheel Machined and Keyed Shaft

Sheave with Bushing

Angle Iron Frame  $1\frac{1}{2} \times 1\frac{1}{2} \times \frac{3}{8}$ "

Latch. Both ends unlatch simultaneously. Tub dumps either way.

Bail Hanger Steel Bar  $\frac{3}{16} \times 1\frac{1}{2}$ " Turned Edgewise

Angle Iron Frame  $1\frac{1}{8} \times \frac{3}{8} \times \frac{3}{8}$ "

Trunnion  
Trunnion support rivetted through two thicknesses of steel

Reinforcing Plate Galvanized Steel  $4\frac{1}{2}$ " wide  $\frac{3}{8}$ " thick

18 Gauge Galvanized Steel

Trip Spring Protected

147 Rivets. Machine rivetted—not spot welded.

M Bearings Machined—not merely cored.

## Special Features of James Carriers

### “Long Life” Tubs

The James Carrier tubs, like the rest of James Equipment, are built to last throughout long years of heavy usage. Although a tub full of wet manure weighs but 650 pounds, the “Big Boy” tubs have been subjected to a test of three times that weight, without breaking or developing any weakness, either in the tubs or the other parts of the carrier outfit. The combination and the “Chore Boy” carriers are of equal strength in proportion to the loads which they are designed to carry.

James tubs are so shaped as to be self-cleaning when dumped, there being no corners where litter can collect. Ends of tubs are rounded, higher than the sides, making them neater in appearance and providing more capacity. Also prevents contents of the tub from binding the bail or clogging the latch and thus interfering with the proper dumping.

Liquid manure is often the last to be loaded, and is apt to settle at the ends; the rounded ends being higher than the sides prevent the liquids from slopping over the ends when you push carrier along the track. This higher rounded end costs much more to build, but it is a feature greatly appreciated by the user, helping to keep hands, clothes and floor clean.

James tubs for the “Big Boy” carriers are constructed of 18-gauge galvanized steel, well riveted, not spot welded, to a framework of galvanized angle iron. 147 rivets are used on the tub. The angle iron at the side edges is  $1\frac{1}{2} \times 1\frac{1}{2} \times \frac{1}{8}$  in. and at the ends  $\frac{7}{8} \times 1\frac{3}{8} \times \frac{1}{8}$  in.; end of tub reinforced with steel plates weighing  $4\frac{1}{2}$  pounds each,  $4\frac{1}{2}$  in. wide by  $\frac{1}{8}$  in. thick. Rivets are  $\frac{3}{16}$  in. sherrardized, excepting corner rivets which are  $\frac{1}{4}$  in.

The heavy angle iron framework, steel plate reinforcing on the ends and the heavy riveting give the James tubs great strength and durability, making the tubs almost indestructible, and absolutely rigid so that they will not rack. The strength of these tubs, and the superior workmanship put into them, cannot well be described; but can be appreciated only on seeing the tubs themselves.

### Bail

When the “Big Boy” carrier is dropped to the floor, there is no horizontal bar in the way to interfere with loading. But when the tub is raised, the bail hangers lock in position against the horizontal shaft, forming a complete bail, and giving necessary rigidity to insure the carrier running steadily along the track.

Thus the bail of the carrier is in place only when a complete bail is needed, and is out of the way while loading the tub.

The bail hangers are heavy, flat steel bars,  $\frac{5}{16} \times 1\frac{1}{2}$  in. with malleable fittings. Being turned *edgewise* to the tub, the bail hangers will not bend when a sudden jerk of the tub puts strain upon them. In carriers where such hangers are turned *flat side* to the tub, sudden endwise jerking of the carrier may bend them, interfering with the operation of the latch and trip.

### Dumps Either Side

Tub can be dumped to either side, according to which side is loaded the heavier. This makes it easier to load the spreader or wagon evenly, and gives greater dumping area.

The simple latches at each end of the tub are so connected as to lock and unlock simultaneously; latches are protected against clogging with manure.

### Trunnion

Trunnion is of malleable, strongly riveted to the bail hanger. Trunnion support is riveted through the two thicknesses of galvanized steel—the end of the tub and the steel reinforcing plate—and the rivets will not pull through.



**“Big Boy” Hoist, with Absolute Control Clutch and Brake**

## Absolute Control Clutch and Brake

PATENTED

This exclusive James feature makes possible the quick lowering of the tub by its own weight, thus saving time in doing the chores—yet keeping the speed of descent under the absolute control of the operator.

The friction brake enables the operator to lower the tub slowly—a sixteenth of an inch, or the entire length of the chain—or drop it quickly to within a few inches of the floor, and stop it almost instantly.

The empty tub can be dropped from an eight-foot track to the floor in five seconds; the “Big Boy,” filled, can be raised to an eight-foot track in from 20 to 25 seconds. The first time you have a chance, compare this record with other carriers, and then figure out for yourself how much time this one feature will save you in a year.

The friction brake and the clutch are both controlled by the one lever, hence both are operated with the one hand. It is not necessary to touch the hand chain when lowering the tub—the one hand and the one lever starts, controls and stops it.

When ready to lower the tub, a quick, strong pull on the control lever will release the clutch and set the friction brake; the pressure on the lever then controls. Release the pressure somewhat and the tub begins to descend; a slight pull slackens the speed regardless of the weight in the tub; a stronger pull stops the descent.

The lever may then be released entirely, setting the clutch instantly, holding the tub firmly at that exact point; the clutch never slips.

This clutch is also a time saver when raising the tub, because it prevents any slipping back, a thing that is so annoying when raising a loaded tub with a hoist using dog and ratchet. The James clutch takes hold so quickly and firmly that, no matter how heavy the load, the James Carrier cannot slip back a fraction of an inch, even though it be raised an inch at a time. There is no lost motion.

There are no ratchet teeth on the James Carrier, nothing to break or get out of order. The X-ray picture on the opposite page shows the simplicity of the mechanism and how it operates. In the picture the clutch is set.

## “Big Boy” Hoist

Even a boy can operate the “Big Boy” carrier. The hoist is so geared as to make possible raising a heavy load in the shortest time without undue effort.

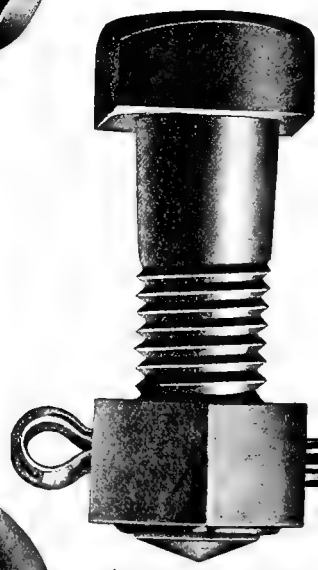
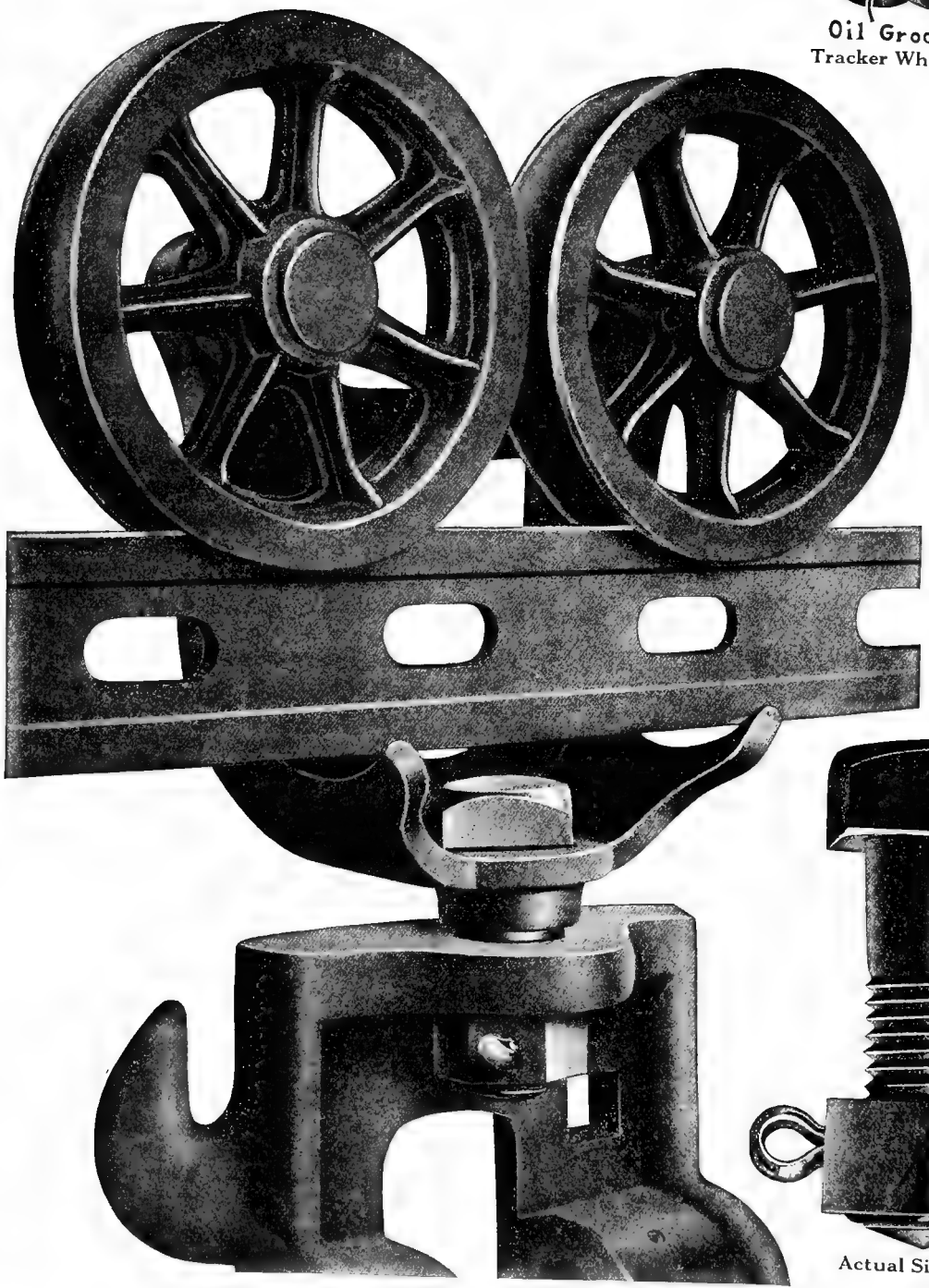
The chain and sprocket type of hoist is used, the chain being the same size as that used to drive most grain binders. Every mechanic knows that this type of hoist has the least friction, excepting only the direct hoist which, however, requires more power.

The worm gear hoists so often used are extremely wasteful of power because of a loss of power through friction; this may be verified by any textbook on the subject, or by any engineer. The mere fact that with worm gear type of carriers the tub will not lower of its own weight, but must be pulled down as well as up, shows how great the friction must be in the worm gear hoist. When the brake and clutch on the James Carrier are both released, the tub drops almost instantly, running free, proving how little the friction is.

The frame carrying the lower sprocket of the “Big Boy” hoist is adjustable to take up any slack in the chain, thus making it possible to overcome the effect of any wear in the lifting apparatus. Hoist is constructed throughout of the best iron and steel. All bearings are machined—not merely cored.



Oil Groove  
Tracker Wheel Axle



Actual Size of bolt



## Simple Chain Guides

Simple chain guides of malleable prevent the hand chain running off the hoist wheel.

### “Long Wheel Base” Tandem Trucks

Each truck has two large, grey iron travelers, mounted tandem in a swiveled tracker wheel frame, like the trucks on a railroad car.

This arrangement keeps the travelers always in alignment with the track, doing away with any tendency to turn and bind, causing friction and wear. It also does away with any tendency to jerk, and make the carrier push hard.

Every farmer who has ever owned or used one of the older style of carriers that run on a flange track, with the tracker wheels side by side, will remember distinctly enough how jerkily and unevenly such a carrier runs on the track, and how hard it was to push.

But how many have ever stopped to figure out the cause of the jerking motion? Perhaps this will explain it.

Each truck of a carrier is hung on a swivel, so that the carrier will take the curve. In order that the trucks may swivel, there must be some play in the swivel joints. When you start to shove the loaded carrier along the track, the friction on the track flanges causes the tracker wheels to lag back—then suddenly the shove on the carrier becomes strong enough to overcome the friction, when the tracker wheels jerk forward.

Then they lag back again—then jerk forward. You who have used such a carrier know how hard it is to push along the track, and how as the swivel wears more and more, the trouble becomes more and more aggravating.

This jerkiness is forestalled in the James Carrier by means of the tandem tracker wheels. For any of the tracker wheels on a James Carrier to lag back or jerk forward, it would be necessary to raise either the front or the rear wheel. Here's an illustration:

Take an ordinary hoe, and hook the shank over the track; give the handle a shove parallel with the track, and it will swing back and forth like the pendulum of a clock.

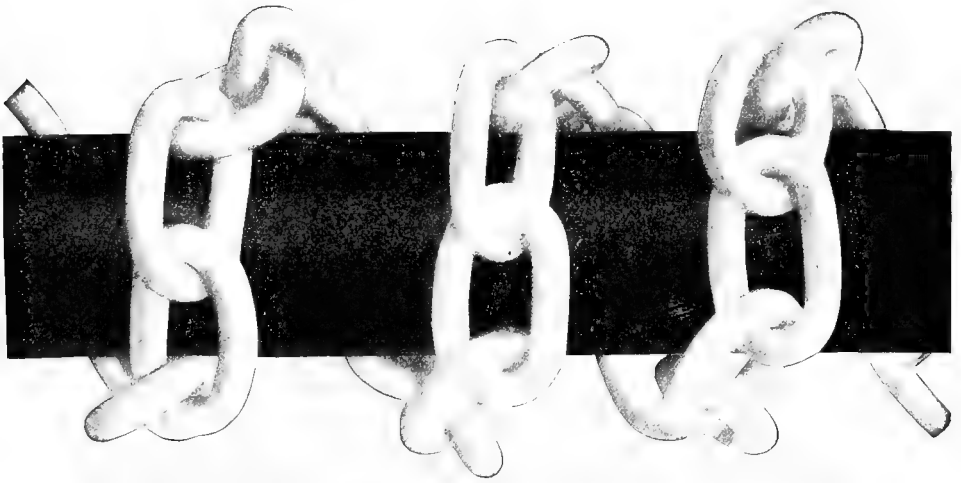
Now take a two prong or two shank garden hoe, and hang this over the track so that both shanks touch the track, giving you a two-point suspension, the same as you have with the James tandem tracker wheels. Now give the handle a shove in line with the track, it will sway back and forth two or three times and settle into position.

This is brought about by the fact that in order to sway, it is necessary to raise one of the two points of suspension. The same principle applies to James tandem tracker wheels.

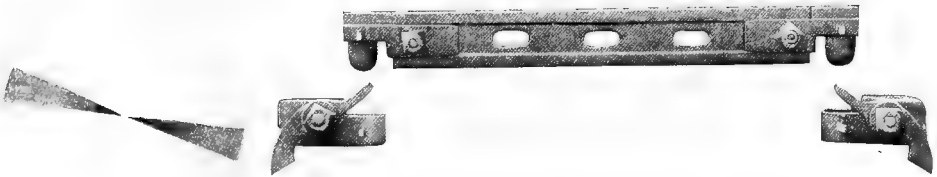
The tracker wheel axle is of lathe-cut steel, the journal being machined and surfaced to size, so that the axle fits perfectly. There is an oil pocket around the axle, which distributes the oil evenly, adding to the life of the carrier and making it run more easily and smoothly. The oil pocket is filled through oil hole in the hub shown in the picture.

### Keeper Prevents Carrier Jumping the Track

The tracker wheel frame is so shaped that it prevents the carrier from jumping the track; in fact, the carrier can be removed only by the human hand, swinging the tracker wheels, wheel frame and frame support to one side and lifting them at the same time.

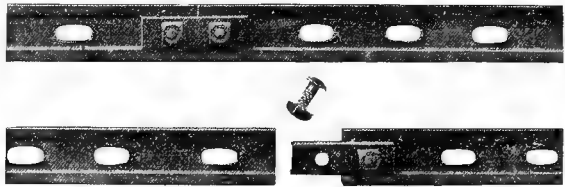


Solid Steel Shaft and Lifting Chain—less than actual size

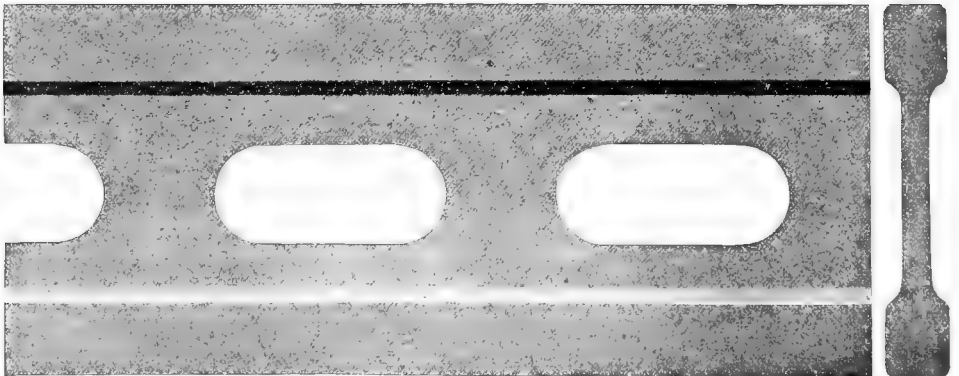


James Removable Track Section

Actual size of shaft



Splice Block for James I-Beam Track



James I-Beam Track—actual size

## Solid Steel Shaft

The shafts used on all James Carriers are of cold rolled, solid steel,  $1\frac{1}{4}$  inches in diameter. The quality of material is the same as that used in factories for line shafting, where its strength and success have been fully proved.

The solid steel shaft will not bend—it may spring a trifle with an overload, but when the weight is removed it immediately springs back into place.

The solid steel shaft is rolled to exact size, and fits the bearings and sprocket perfectly, leaving practically no chance for any play and wear. Tubing, on the other hand, though often used for carrier shafts, is not suited to the purpose, because it varies in size, and cannot be made to fit accurately; and because tubing once bent, remains bent.

## Lifting Chain

The lifting chain or cable is the weakest point in many carriers—the limited winding space on the shaft making it necessary to use small chain or cable of insufficient strength.

The lifting chain on James Carriers has the full length of the shaft on which to wind; heavy, straight link chain is used, this being strongest and best suited to the purpose.

It is attached to the center of the shaft and winds up in such a way that it forms an open spiral—the chain does not climb upon itself, causing it to rub and wear. Chain is tested for five times the load it will have to carry.

The three point suspension distributes the load equally along the shaft; and gives a double purchase, making it easier to raise the tub.

## High Lift Feature

The long winding space on the shaft makes it easy to transform the carrier into a high lift carrier, by merely putting on longer lifting chains. There is plenty of room on the shaft for all the chain required for any ordinary height of ceiling.

The James Carrier tubs raise closer to the track than others, thus oftentimes avoiding the necessity of excavating when there is a rise of ground just outside the door; the carrier more readily clears the spreader or wagon, and the manure can be piled higher when it is necessary to let it accumulate in the yard.

The "Big Boy" Carrier with tub, in raised position, measures but three feet from bottom of track to bottom of tub.

## Removable Track Sections

Used to permit closing of sliding doors; also used where two tracks cross, and for other necessary openings. When removed, automatically sets stop blocks, making it impossible for a carrier to run off the open ends of the track.

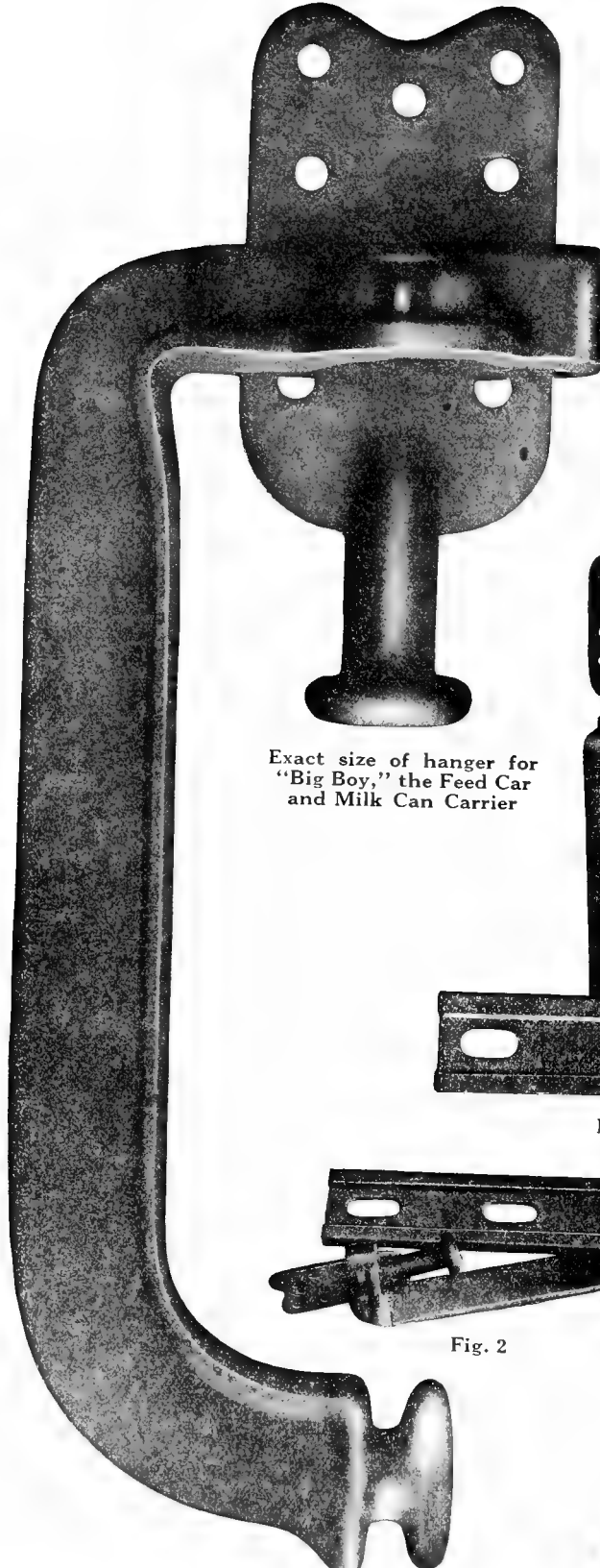
Standard length is fourteen inches, but for driveways, etc., can be supplied any length.

## I-Beam Track

(PATENTED)

The James Track has many important advantages not possessed by other tracks.

In the first place, it can be quickly and easily put up, even by inexperienced help—in fact, is easier to erect than any rod track. And once in place, it is there to stay.



Exact size of hanger for  
"Big Boy," the Feed Car  
and Milk Can Carrier

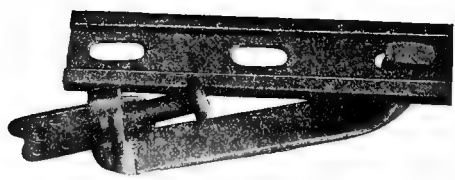


Fig. 2

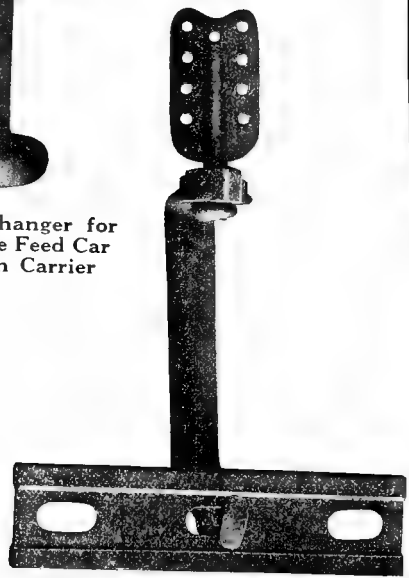


Fig. 3



Fig. 4



Fig. 5



Fig. 6

Fig. 1

There is nothing about it that will give, spread, loosen or get out of order; it is trouble proof—and will stand up under long years of heavy service.

No bolts or nuts are required for putting track and hangers together. The hangers "button" to the track and the nailing plates "button" to the hanger, the plates being nailed to the joists. If the barn is ceiled, ceiling plates with large screws are used instead of nailing plates. The few simple instructions sent with each order, enable any one to get a first-class job, with the track perfectly levelled.

James I-Beam track saves the cost of special curves. The track may be quickly and easily bent to any curve while it is being put up in the barn—heat is not required to do the bending. As several curves are often necessary in a barn, and as these curves cost several dollars apiece when ordinary flange track is purchased, this saving is no small item; and is a very big one if the track is for a round barn.

Many litter carriers use a track that is not at all adapted to the litter carrier. A track that is flat has but little strength vertically.

When used outside the barn, snow and sleet accumulate on the flat surface, blocking the carrier wheels. Before the carrier can be used outside, the snow or ice must be cleared from the track by melting or scraping it off—and this is no easy task, for the track is up high. Inside the barn, a flat track allows the dirt to accumulate.

The James Track is different. Its narrow tread affords no place for snow or sleet or dirt to collect—no sleet storm will put it out of use just when you need it most, in the disagreeable weather.

The narrow tread of the James track offers little resistance to the travellers; there being little friction surface, the carrier runs easily.

Track being one piece cannot spread and bind the tracker wheels.

The depth of the track and its heavy flanges at top and bottom make the James track stiff—it does not spring under heavy loads. This in part accounts for the ease with which big loads are handled on the James track. Any track without the necessary vertical strength will spring, making "low spots" in between hangers; and the carrier will push hard and jerkily.

The depth of the James track gives it long life because of the greater thickness of wearing surface; when the upper bead has worn thin, if it ever does, track can be turned edge for edge, the bottom bead forming new running surface. It will be giving satisfactory service many years after ordinary flat track has gone to the junk pile.

In fact, James track meets every condition required of a litter carrier equipment in any barn; it may be hung high or low, and run wherever there is room for the tub to pass.

The shape of the track is something like that of a railroad rail and for just the same reason. When the first railroad was constructed, a flat track was used, and soon abandoned for the present shape, in order to secure greater strength, longer wear and an even running surface.

It is heavy at the points of greatest strain. The weight on top puts the compression strain where the track is heavy; and the pulling strain where the track is just as strong. The compression strain and the pulling strain neutralize each other at the center of the track—less strength is required there, and hence that part of the track is made lighter. Every particle of metal helps to support the load, and the James track is therefore many times stronger than other types of track of equal weight.

Made of high carbon steel, same as a railroad rail; two inches deep; is easily put together with the channel steel splice bars and  $\frac{7}{16}$ -in. bolts—the track will not come apart and the joints will not give or sag. Holes in the track are two inches apart on centers.

## James Track Hangers

PATENTED

We call them the "button-on" hangers, because of the peculiar shape which does away with the use of bolts and nuts for attaching the hangers to the track.

In putting up the track, the hangers "button on"—you put the button of the hanger through the hole in the track, slip the nailing plate through hole in the hanger, turn to position desired and fasten to joist or ceiling. (See Figs. 1, 2 and 3, page 236.)

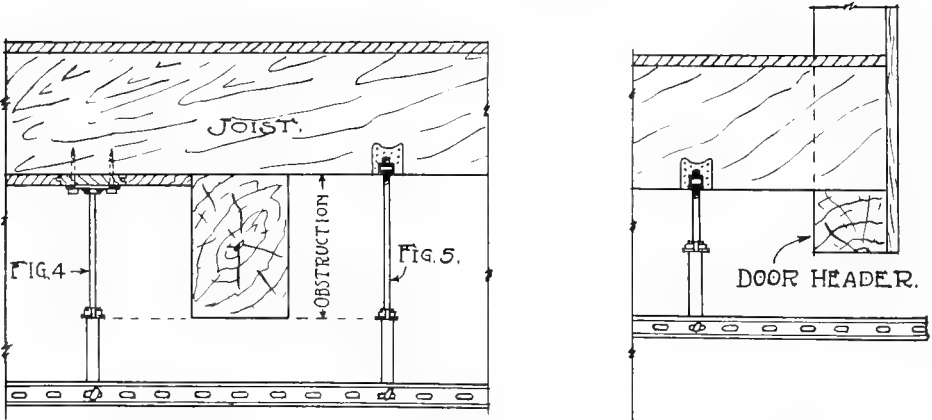
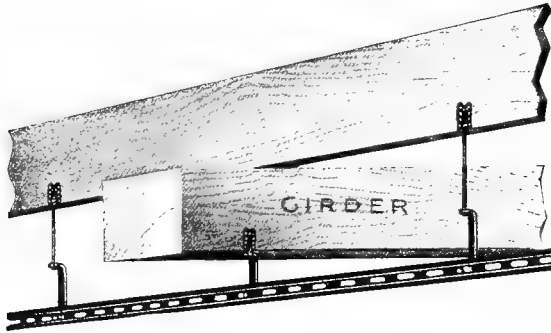
Nailing plates (Fig. 3) or nailing plates with extension bolts (Fig. 5) are used for attaching to joists. If the barn is ceiled, ceiling plates with extension bolts (Fig. 4) of proper length are used with the hangers.

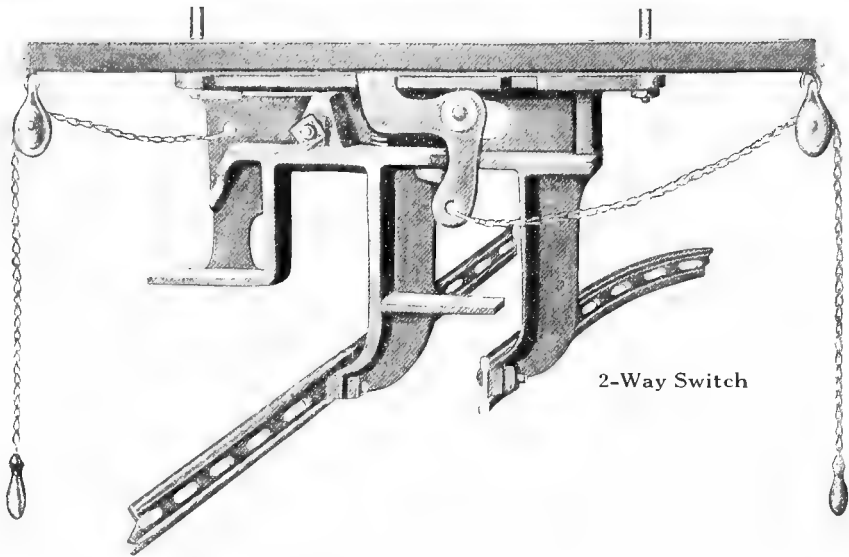
For the "Big Boy," the Combination Carrier, the Feed Carrier and the Milk Can Carrier, but the one style of hanger is required. Various lengths of extension bolts make it easy to drop the track any distance from the ceiling. And with either nailing plates or ceiling plates, it is a simple matter to level the track perfectly. No bolts being used in attaching hangers to the track, there are no nuts to rattle loose or come off—the track is held firmly.

**STOP BLOCK:** There is no extra cost for special stop blocks, none being required. Any hanger inserted on the opposite side of the track from the other hangers acts as a stop block, as well as supporting the track. The stop block, being "buttoned on," cannot work loose—making it impossible for the carrier to run off the end of the track.

Made of best malleable iron—they will not break.

Hangers should be used not more than 32 inches apart.





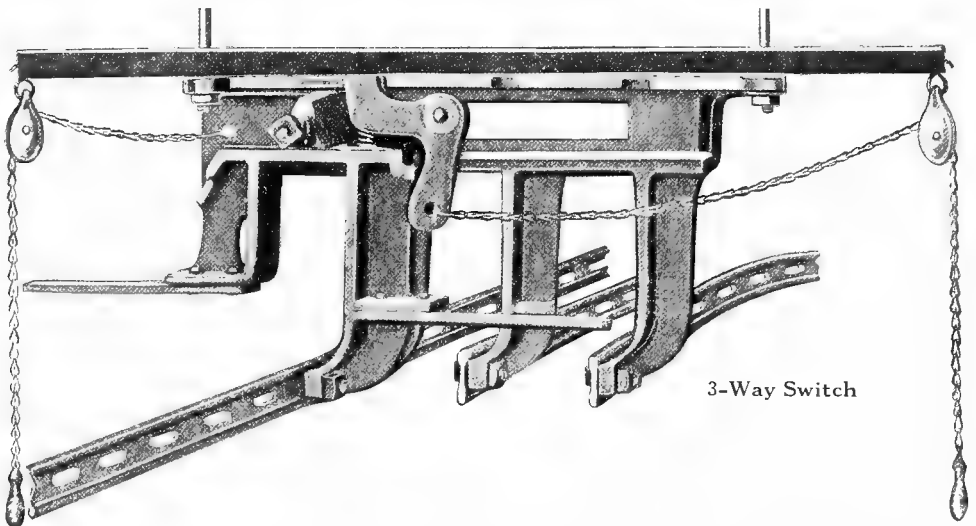
## James Safety Switches

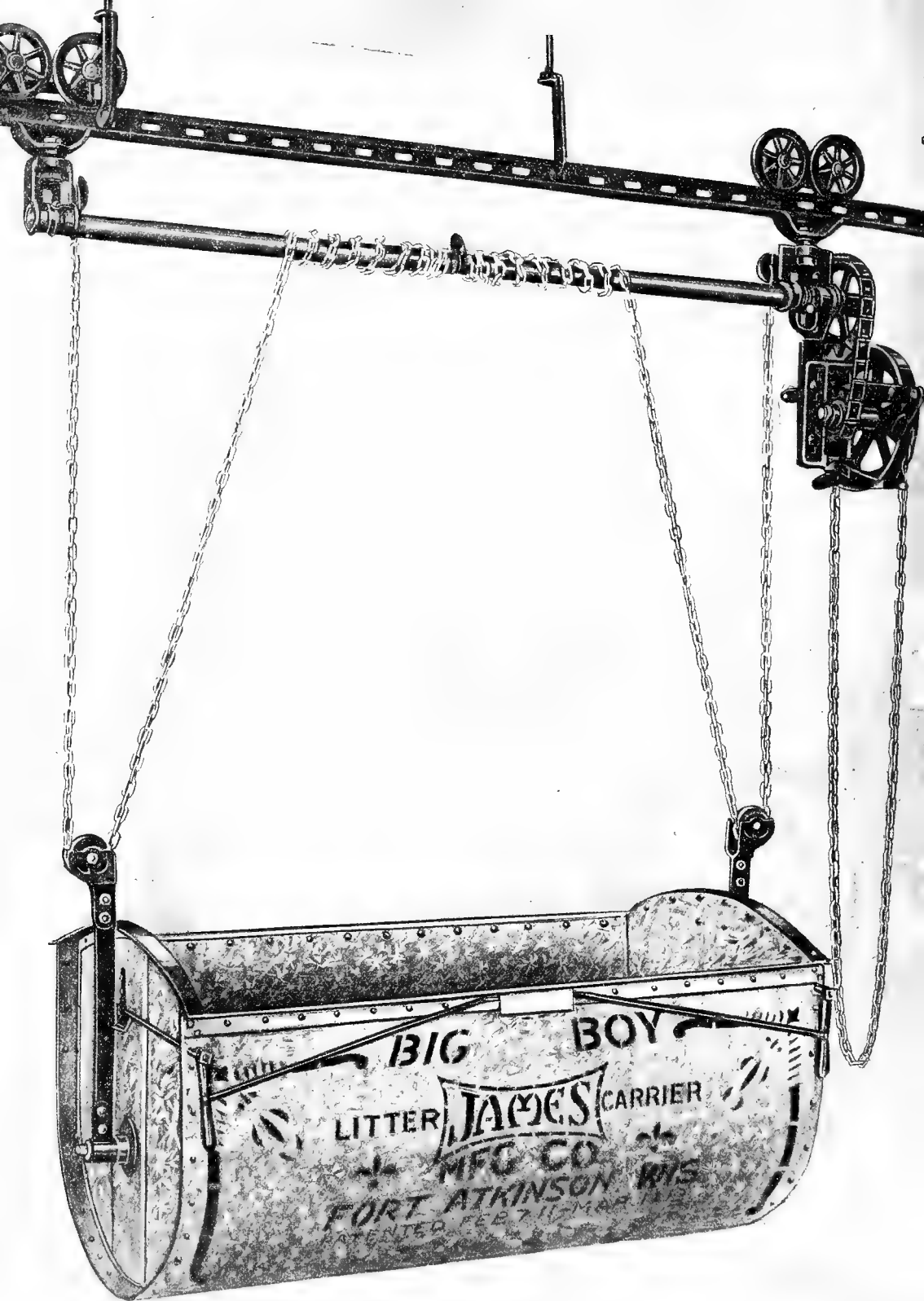
Patented

Anyone who has had experience with the unsatisfactory devices used in the past for transferring a carrier from one section of track to another section, will appreciate the James Safety Switch.

It can be operated conveniently from below, no matter how high the track is hung; a pull on the chain unlocks the switch and transfers to the other track, at the same time setting stop blocks across the open ends; there is never any possibility of a James Carrier running off the track, for a projection on the switch arm blocks the open tracks. When the pull on the chain is released, the switch automatically locks in place.

The James Safety Switch is the simplest, surest and easiest in operation; being constructed of best iron, it is strong and durable. Switches are reversible, and either two-way or three-way switches are furnished; both operate in the same manner.





BIG BOY

LITTER CARRIER

JAMES

MFG CO

FORT ATKINSON WIS

PATENTED FEB 7 1894



## The "Big Boy" Litter Carrier

(PATENTED)

## Specifications

**TUB:** Constructed of eighteen-gauge galvanized sheet steel, built on a framework of angle iron; angle iron at side edges being  $1\frac{1}{2} \times 1\frac{1}{2} \times \frac{1}{8}$  in.; at the ends  $\frac{7}{8} \times 1\frac{3}{8} \times \frac{1}{8}$  in.; end of tub reinforced with steel plate  $4\frac{1}{2} \times \frac{1}{8}$  in. Well riveted, all rivets sherardized and are  $\frac{3}{16}$  in., except corner rivets, which are  $\frac{1}{4}$  in. Gudgeon support is riveted to the two thicknesses of steel on end of tub. The tub is self-cleaning. For complete information see page 229.

**PERFECT CONTROL CLUTCH AND BRAKE:** Of malleable and bar steel. For explanation of operation see page 231.

**HOIST:** Chain and sprocket type. Made of best iron and steel. The frame carrying the lower sprocket is adjustable to take up the slack, thus making it possible to overcome any wear. So geared as to make possible the raising of heavy loads in the shortest time without undue effort. (See page 231.)

**CHAIN GUIDES:** Malleable. Prevent hand chain running off the hoist wheel.

**SHAFT:** Of  $1\frac{1}{4}$ -in. cold rolled solid steel shafting, same as used in factories for line shafting. (Page 235.)

**LIFTING CHAIN:** Heavy straight link chain, tested for five times the load it will have to carry. Three-point suspension: in winding up forms an open spiral, preventing rubbing and wear. (Page 235.)

The distance from the top of the tracker wheels to the bottom of the Big Boy No. 2 Tub when raised is 44 inches; when lowered to full length of lifting chain the distance is 8 feet 8 inches.

**TRACKER WHEELS:** Made of gray iron;  $4\frac{3}{4}$  in. in diameter, mounted in swiveled tracker wheel frames. Travelers arranged tandem. Tracker wheel axle of steel with oil pocket; journal machined and surfaced. (See pages 232-233.)

**TRACKER WHEEL FRAME:** So constructed that wheels cannot jump the track. May be removed only by hand. (Page 232-233.)

**LATCH AND TRIP:** Latches at each end of the tub lock and unlock simultaneously. Protected against clogging with manure. Latch trip operated from either end.

**BAIL HANGERS:** Heavy flat steel bars  $\frac{5}{16} \times 1\frac{1}{2}$  in., edgewise to the tub. Malleable fittings and sheave. (See page 229.)

**BEARINGS:** All bearings that get much wear in operation are machined to assure accurate fit and smooth surface; this reduces friction, lessens wear, increases ease of operation and adds greatly to life of carrier. Bearings that are left merely cored, as they come from the foundry, are covered with sand roughness, which cuts into metal like so much emery. Hence the great importance of machined bearings. (See page 228.)

**CAPACITY:** Tub is 45 in. long, 24 in. deep, 24 in. wide, and holds approximately 12 bushels coarse manure.

**WEIGHT:** Approximately 200 pounds.



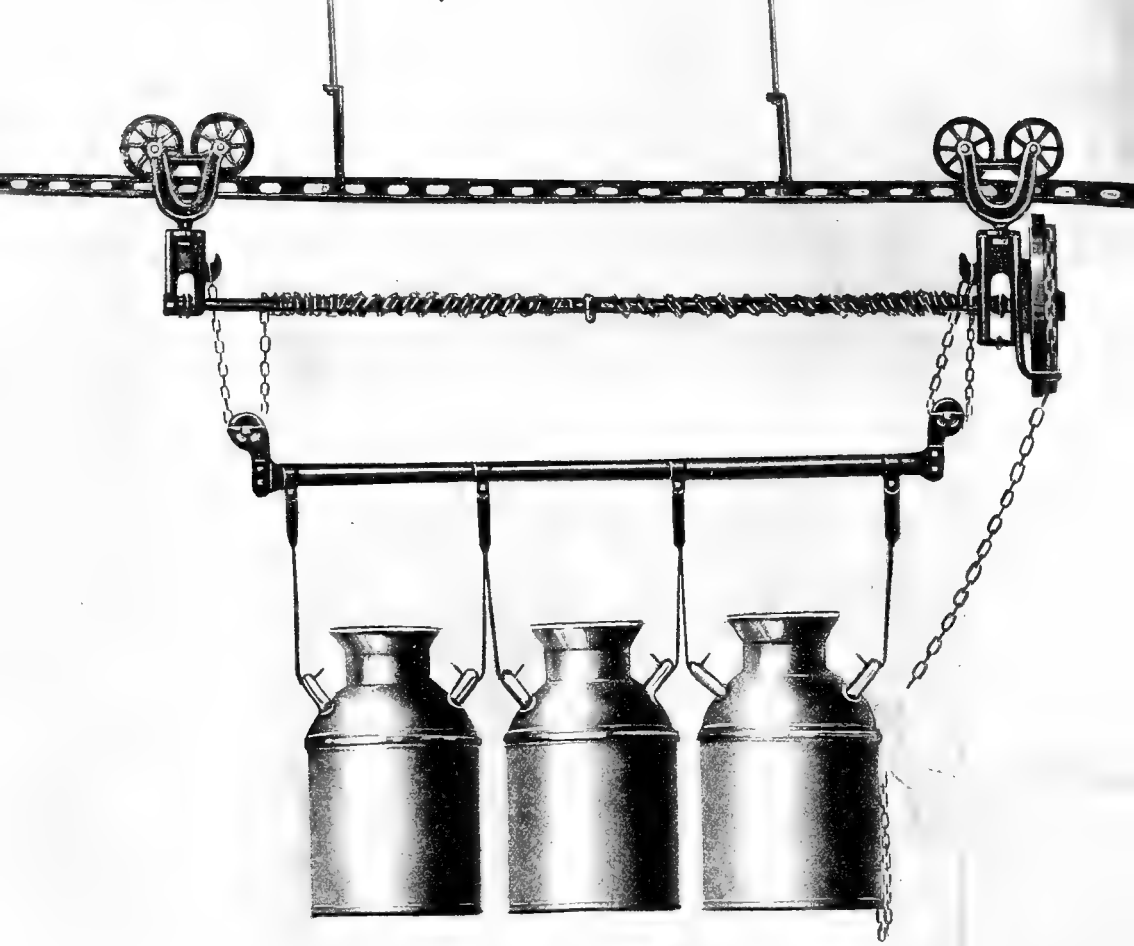
THE  
FEED **JAMES** CAR  
MFG. CO  
FT. ATKINSON, WIS.

# The James Feed Car

(PATENTED)

## SPECIFICATIONS

- TUB:** Constructed of selected lumber; bottom and ends 20-gauge galvanized steel, the design making it easy to shovel. Corners bound with corner iron.
- SIZE:** Extreme length 68 inches, width 26 inches, height 24 inches.
- PERFECT CONTROL CLUTCH AND BRAKE:** Of malleable and bar steel. For explanation of operation see page 231.
- HOIST:** Chain and sprocket type. Made of the best iron and steel. The frame carrying the lower sprocket is adjustable to take up the slack, thus making it possible to overcome any wear. So geared as to make possible the raising of heavy loads in the shortest time without undue effort. (See page 231.)
- CHAIN GUIDES:** Malleable. Prevent hand chains running off the hoist wheel.
- SHAFT:** Of 1¼-in. cold rolled solid steel shafting, same as used in factories for line shafting. (Page 235.)
- LIFTING CHAIN:** Heavy straight link chain, tested for five times the load it will have to carry. Three-point suspension; in winding up forms an open spiral preventing rubbing and wear. (Page 235.)
- TRACKER WHEELS:** Made of gray iron; 4¾ in. in diameter mounted in swiveled tracker wheel frames. Travelers arranged tandem. Tracker wheel axle of steel with oil pocket; journal machined and surfaced. (See page 233.)
- TRACKER WHEEL FRAME:** So constructed that wheels cannot jump the track. May be removed only by hand. (Page 233.)
- BAIL:** Heavy channel steel. Extends nearly to bottom of tub. So shaped as to permit the greatest freedom when shoveling.
- BEARINGS:** All bearings that get wear in operation are machined, to assure accurate fit and smooth surface; this reduces friction, lessens wear, increases ease of operation and adds greatly to life of carrier. Bearings that are left merely cored, as they come from the foundry, are covered with sand roughness, which cuts into metal like so much emery. Hence the great importance of machined bearings. (See page 228.)
- CAPACITY:** Approximately 16 bushels.
- WEIGHT:** 250 pounds.



James Milk Can Carrier

## Milk Can Carrier

(PATENTED)

Where the James I-Beam Track is already installed in the barn, the Milk Can Carrier outfit costs but very little, the only additional cost being for the carrier itself with perhaps a little additional track to reach the Milk House.

The James Milk Can Carrier is a distinct improvement over the platform carrier from which cans not only slip off in going around a curve but with which it is necessary to lift cans on and off.

The James Carrier may be lowered to the floor and the hooks quickly released from the can handles. The friction clutch makes it possible to lower and hold the cans within an inch of the floor, preventing them from coming in contact with any litter and keeping the cans clean.

### SPECIFICATIONS

**PERFECT CONTROL CLUTCH AND BRAKE:** Of malleable and bar steel.  
For explanation of operation see page 231.

**HOIST:** Because of the lighter load handled by the Milk Can Carrier the direct type hoist is used. (See page 231.)

**CHAIN GUIDES:** Malleable. Prevent hand chain running off the hoist wheel.

**SHAFT:** Of 1¼-in. cold rolled solid steel shafting, same as used in factories for line shafting. (Page 235.)

**LIFTING CHAIN:** Heavy straight link chain, tested for five times the load it will have to carry. Three point suspension; in winding up forms an open spiral preventing rubbing and wear. (Page 235.)

**TRACKER WHEELS:** Made of gray iron; 4¾ in. in diameter, mounted in swiveled tracker wheel frames. Travelers arranged tandem. Tracker wheel axle of steel with oil pocket; journal machined and surfaced. (See page 233.)

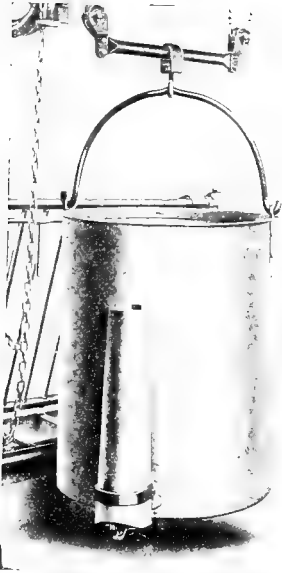
**TRACKER WHEEL FRAME:** So constructed that wheels cannot jump the track. May be removed only by hand. (Page 233.)

**BEARINGS:** All bearings that get wear in operation are machined, to assure accurate fit and smooth surface; this reduces friction, lessens wear, increases ease of operation and adds greatly to life of carrier. Bearings that are left merely cored, as they come from foundry, are covered with sand roughness, which cuts into metal like so much emery. Hence the great importance of machined bearings. (See page 228.)

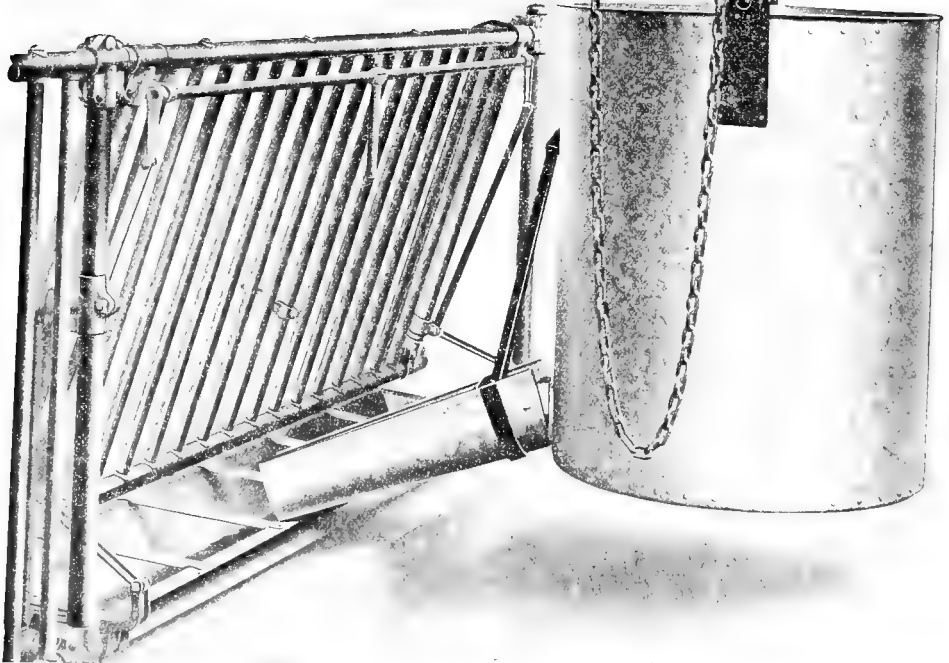
Instead of a suspended tub or platform the milk cans are suspended from a carbon steel pipe, fitted with a sheave on each end, through which runs the lifting chains that wind over the steel shaft. Suspended from the pipe are steel straps with hooks which grapple the milk can handles. Sufficient distance between these supports is provided to admit the use of a strainer; the cans need not be detached, from the time they are taken empty from the milk-house until they are returned.

**CAPACITY:** Will handle either 1, 2 or 3 milk cans.

**WEIGHT:** Approximately 110 pounds.



James  
Swill  
Carrier



# James Swill Carrier

## SPECIFICATIONS

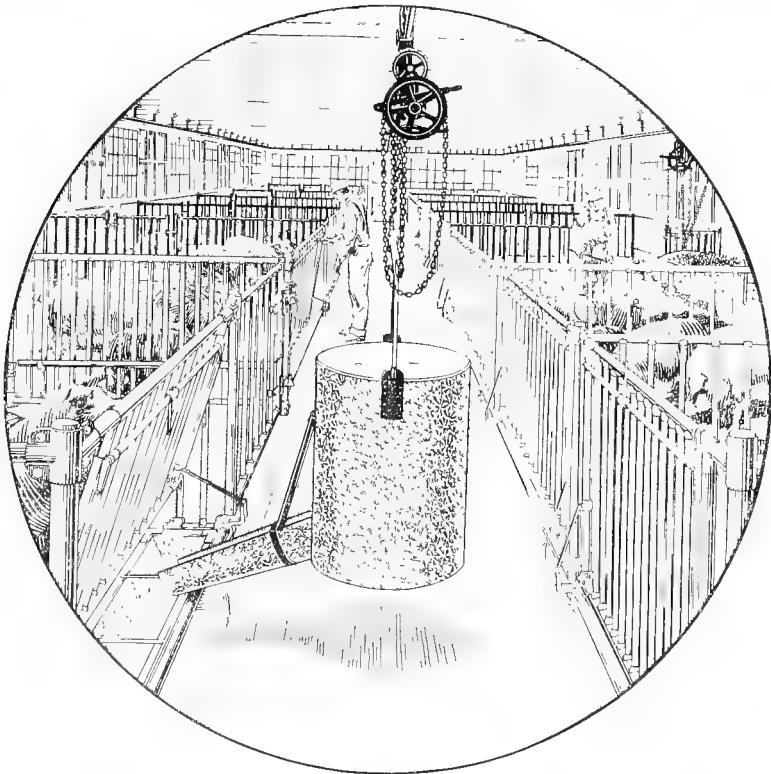
Capacity of can 70 gallons.

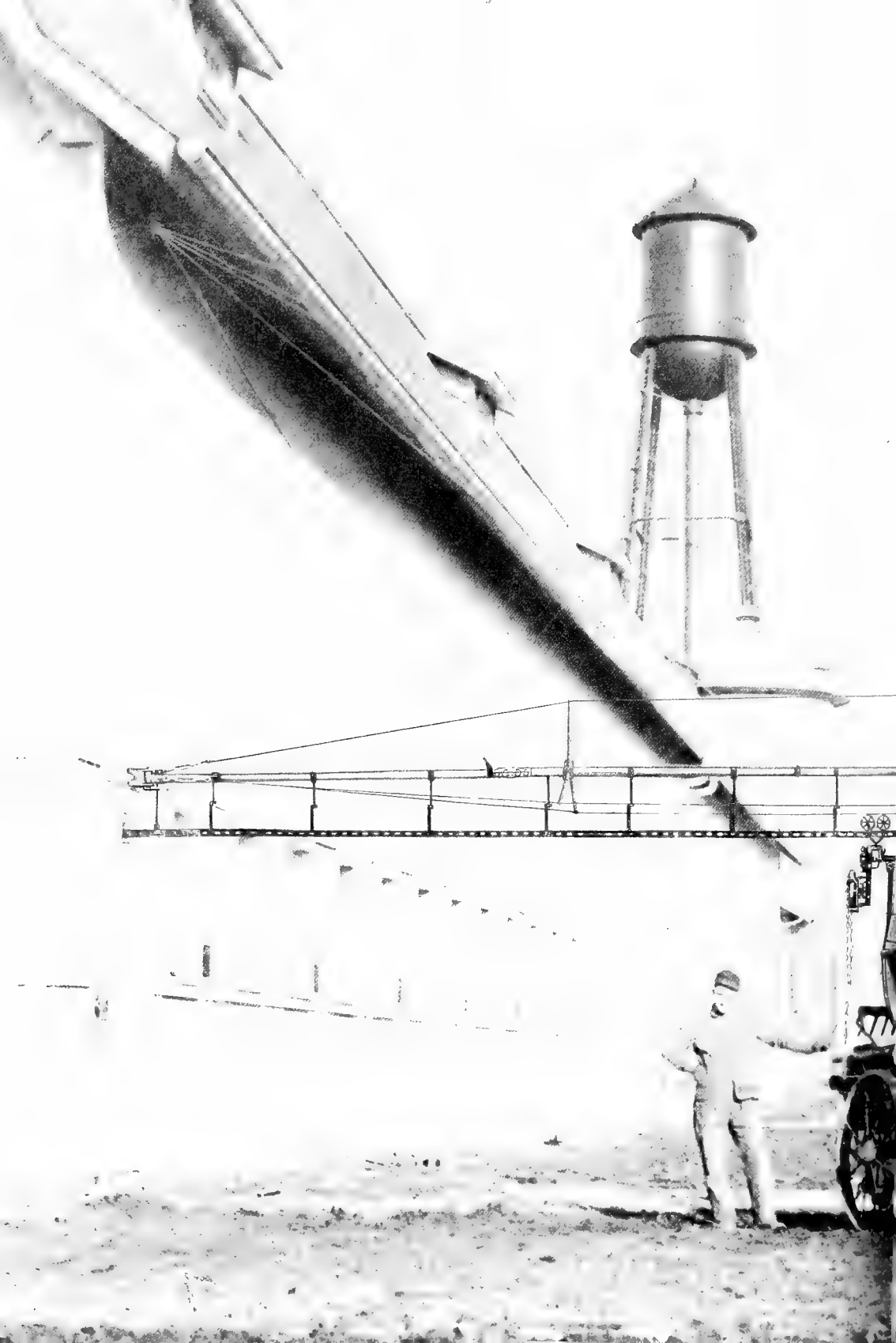
Outside dimensions 28 inches diameter by 32 inches high.

The can is constructed of 18-gauge galvanized steel, lock seamed and well riveted to a framework of angle and channel iron. The top is reinforced with  $\frac{7}{8}$ -in. x  $1\frac{3}{8}$ -in. x  $\frac{1}{8}$ -in. angle iron, bottom rim with a  $1\frac{1}{2}$ -in. x  $\frac{3}{4}$ -in. x  $\frac{1}{8}$ -in. channel iron. Two pieces of  $1\frac{1}{4}$ -in. x  $1\frac{1}{4}$ -in. x  $\frac{3}{16}$ -in. tee iron is placed horizontally under bottom sheet, well riveted to channel, giving great supporting strength. A heavy galvanized collar is riveted and soldered to the can and fitted with a 3-in. gate.

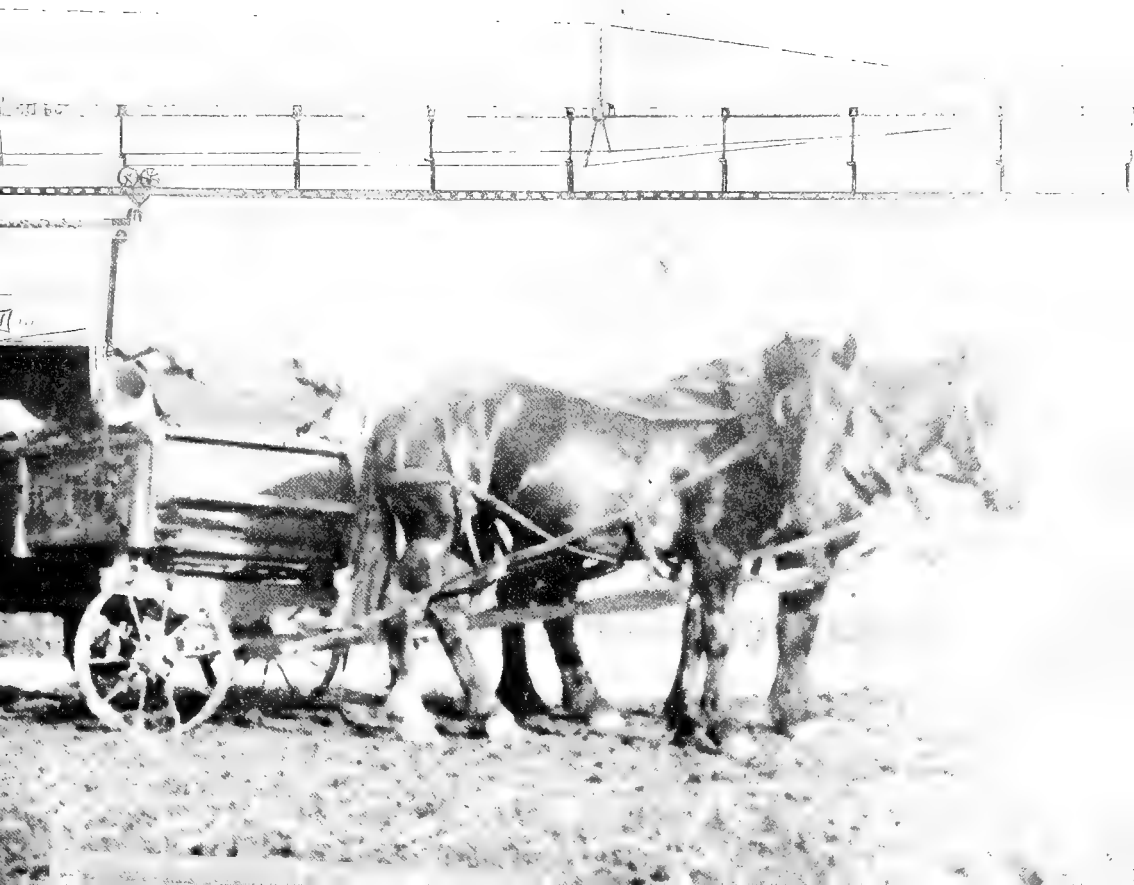
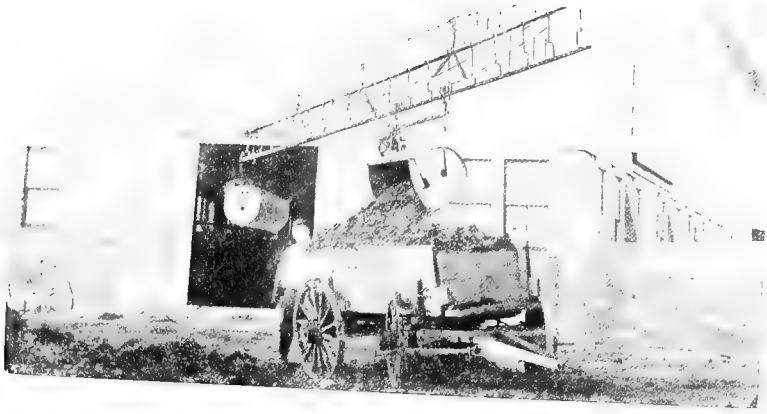
Bail hangers are heavy galvanized steel plate riveted to barrel with 20 Sherardized rivets; seams and rivet heads are well soldered on inside.

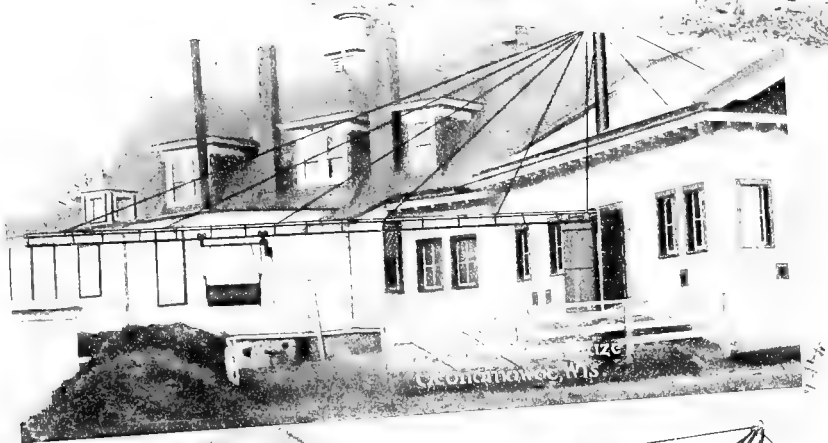
HOIST: The Big Boy hoist is furnished (see page 231) fitted with extra strong pipe, swivel and hook, allowing swill to be delivered on either side of feeding alley.











## James Swinging Steel Crane

The James swinging steel crane is the most satisfactory method of supporting the track outside the barn, and costs but little more than the cumbersome, old-time heavy timber supports. It leaves the yard entirely clear, there being no supporting posts to interfere with the use of the yard, or to cause injury to horses or cattle; nor is there any lumber to rot and break. It keeps the yard next to the barn free from manure, because when not convenient to dump on to spreader or wagon, carrier can be dumped on an emergency pile some distance from the barn.

The carrier track can be extended beyond the swinging crane, if desired, by the use of the steel arch support shown on pages 254 and 256, or a wood support.

The carrier will pass over the flexible track section readily, even when the crane is swung as much as 30 or 35 degrees to either side from the direct line of carrier track leading to crane; and hence makes possible a dumping area eight or ten times greater than the post supported track of the same length, should it be necessary to allow manure to accumulate.

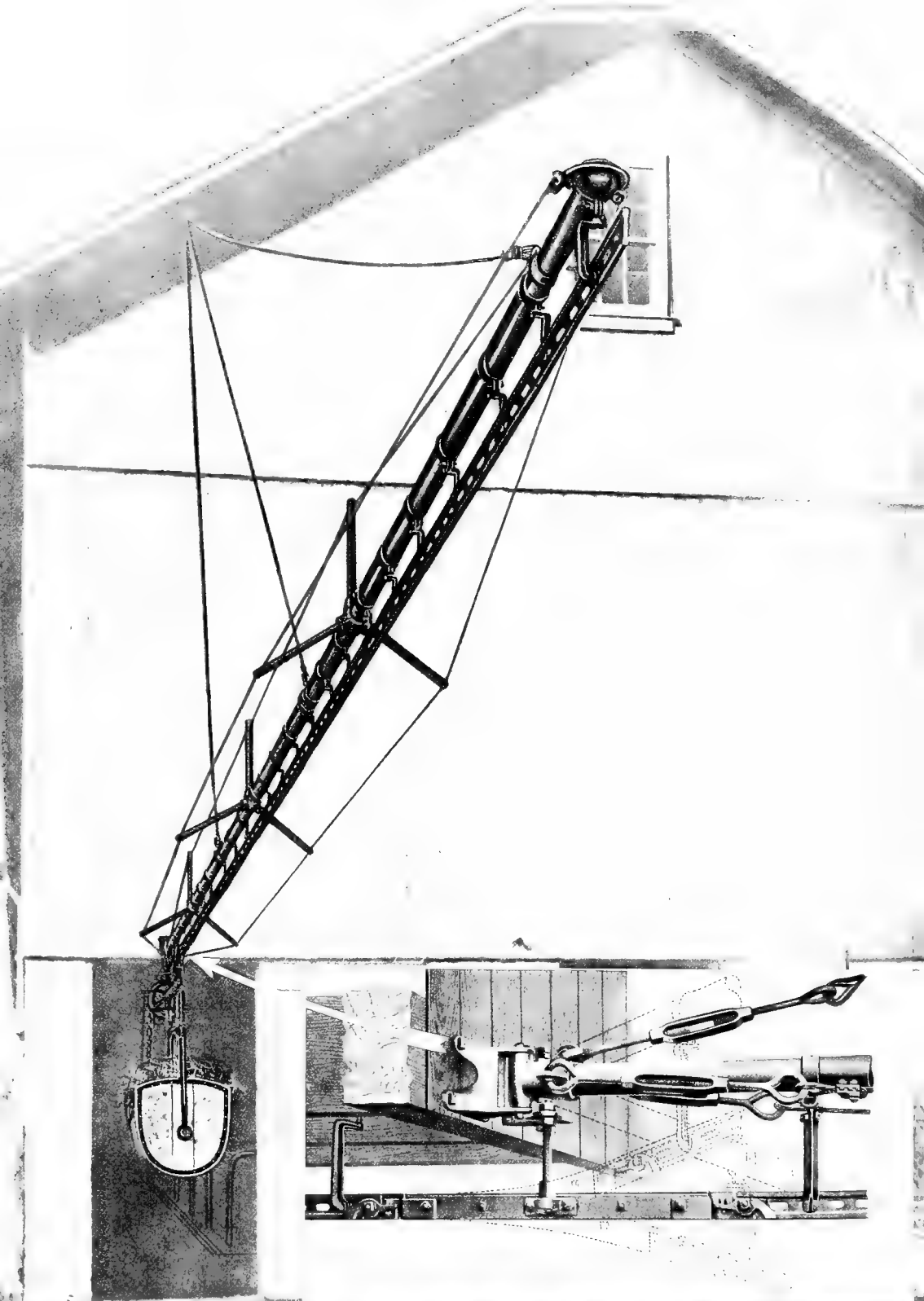
When necessary to drive close to the barn with a load of hay, the crane may be swung against the side of the building either to the right or to the left where it is out of the way.

The length of crane that may be used, if suspended from the barn itself, is dependent on the height of the building. It should usually not exceed two and a half times the distance from the top of the door to the point where the eye bolt holding the supporting cable is attached.

For instance, if the distance from the top of the door to the plate on which the rafters rest and which holds the eye-bolt is 14 feet, the crane should not exceed 35 feet; if this distance is 16 feet, a 40-ft. crane may be used, etc. In but very few cases would we recommend a crane over 40 feet in length.

By erecting the proper supports, it is usually possible to secure the advantage of the swinging crane, even though the building be low or other conditions apparently prevent. Examples are shown on page 250. If you want to use a crane and do not know how to support it on your barn, write us and our Service Department will be glad to help you solve the problem.

The track inside the barn and the track supported from the crane are connected by the removable flexible section shown on page 252.



James Goring's Crane

# James Swinging Steel Crane

## SPECIFICATIONS

Carrier cranes being subject to considerable shock, unusual care has been taken to give the James crane great rigidity to prevent buckling. The lateral and vertical strength is furnished by the horizontal and vertical trussed stiffening struts set at frequent intervals. The crane is designed to carry 800 pounds when the load is at the maximum radius of 40 feet.

Galvanized pipe (not merely painted),  $2\frac{3}{8}$ -in. O. D., connected by heavy malleable splice clamps; truss braces of  $1\frac{5}{8}$ -in. O. D. pipe. Truss struts of  $1\frac{5}{8}$ -in. O. D. pipe placed 120 degrees to each other. Three side truss cables  $\frac{5}{16}$ -in. in diameter with  $\frac{1}{2}$ -in. turnbuckles; size and number of guy cables vary according to length of crane; with the 40-ft. crane four  $\frac{5}{16}$ -in. and one  $\frac{3}{8}$ -in. cables are furnished, with necessary cable clips and clamps.

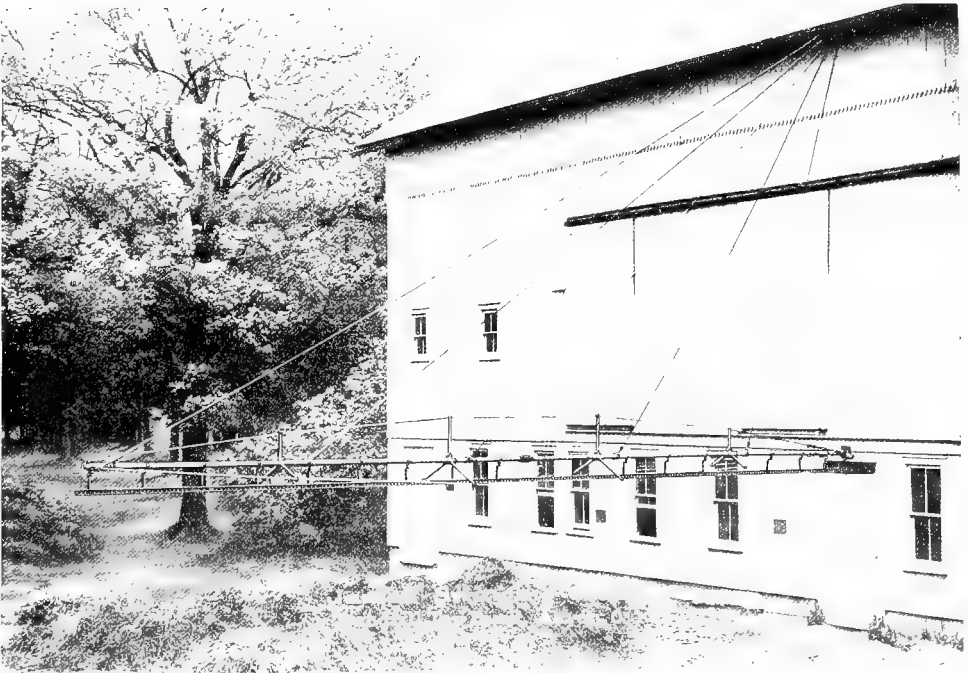
The hinge is of best malleable iron with 1-in. diameter steel bolt.

Hook bolt, 1 in. thick, with iron washer, special design, to prevent cables from unhooking, for attaching upper end of guy cables to barn.

## Removable Flexible Track Section

Each swinging crane is furnished with a section of flexible track which is located directly under the crane hinge. The flexible track is built up from 14 pieces of tempered flat spring steel set on edge, carefully machined and assembled. All internal parts thoroughly coated with flake graphite and oil.

This flexible track is eccentrically hung from crane hinge thus avoiding buckling.



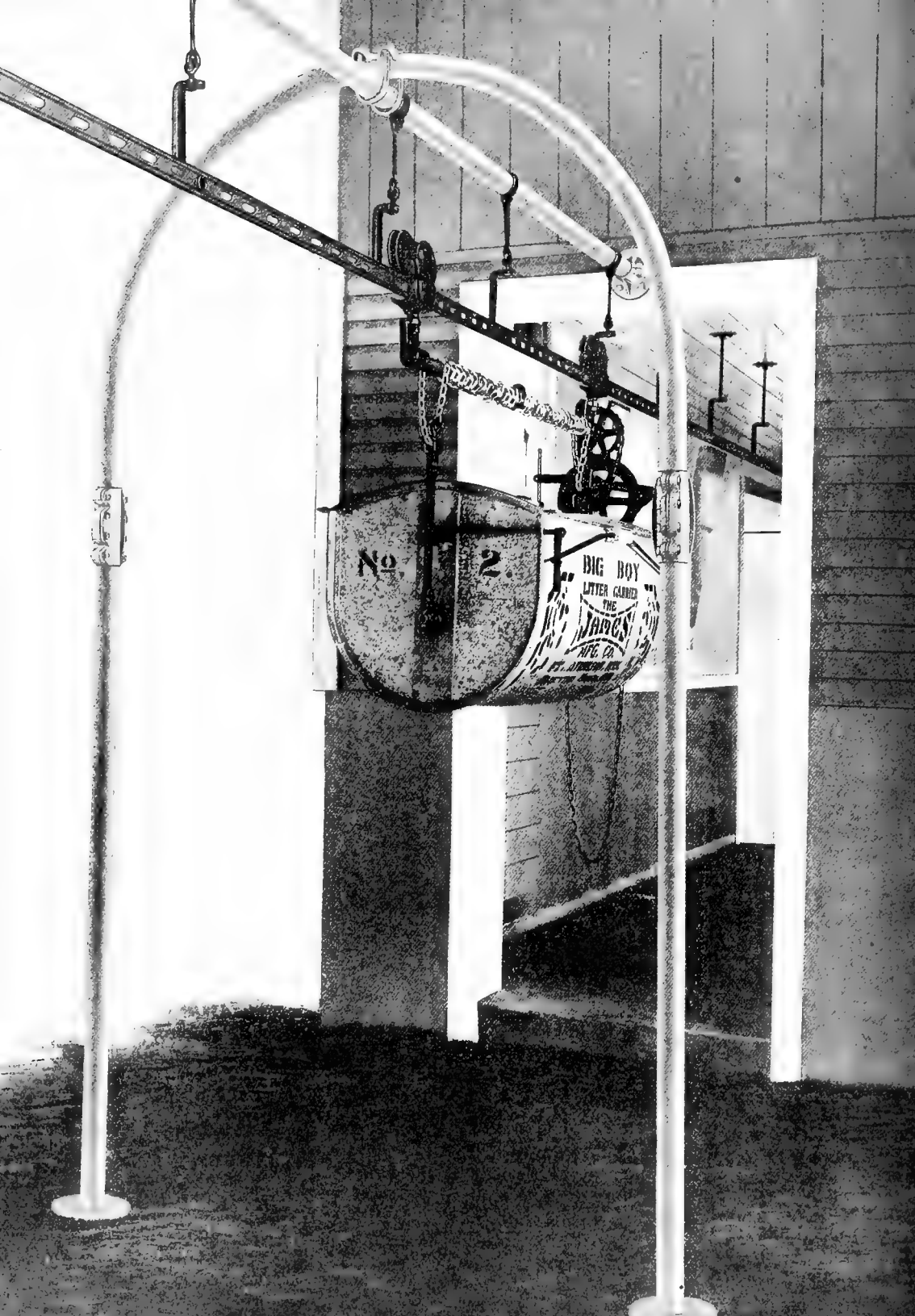


Inside Support for James Carris



One Best Wood Support  
D.D. Tenney Shorewood Farm.





James Carrier Outside Support.



# Supports for James Track Outside the Barn

(PATENTED)

## Steel Arch Support

As shown on page 256. Constructed of  $2\frac{3}{8}$ -in. O. D. pipe, galvanized, with malleable fittings and  $\frac{1}{2}$ -in. U-bolts on top and  $\frac{7}{16}$ -in. bolts in coupling clamps. The uprights in each pair of posts are five feet apart, on centers set in concrete. Very satisfactory track support. Furnished any height.

## Supports Alongside the Barn

Sometimes it is necessary to carry the I-Beam track along the outside of the barn.

If a Combination Carrier is being used, it may not be possible to run the rod track out into the yard directly from the door; in such case the track can be supported from the side of the barn, carrying the I-Beam track to a point from which the rod track can be run out as desired.

Or in some barns where the rows of cows run crosswise, it may be desirable to bring the track out of one door and in to another in order to reach certain parts of the stable—especially if it happens that alleys are too narrow to permit the passage of the carrier.

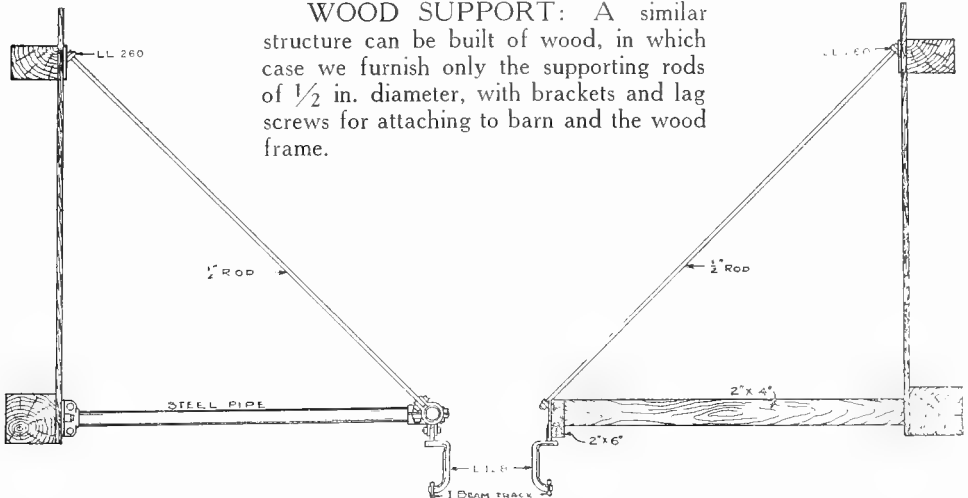
Track supported from the side of the barn may also be used in cases where a swinging crane cannot be extended from the door itself, some other building, for instance, being in the way. It is easy to carry the I-Beam track to a point from which a crane may be swung.

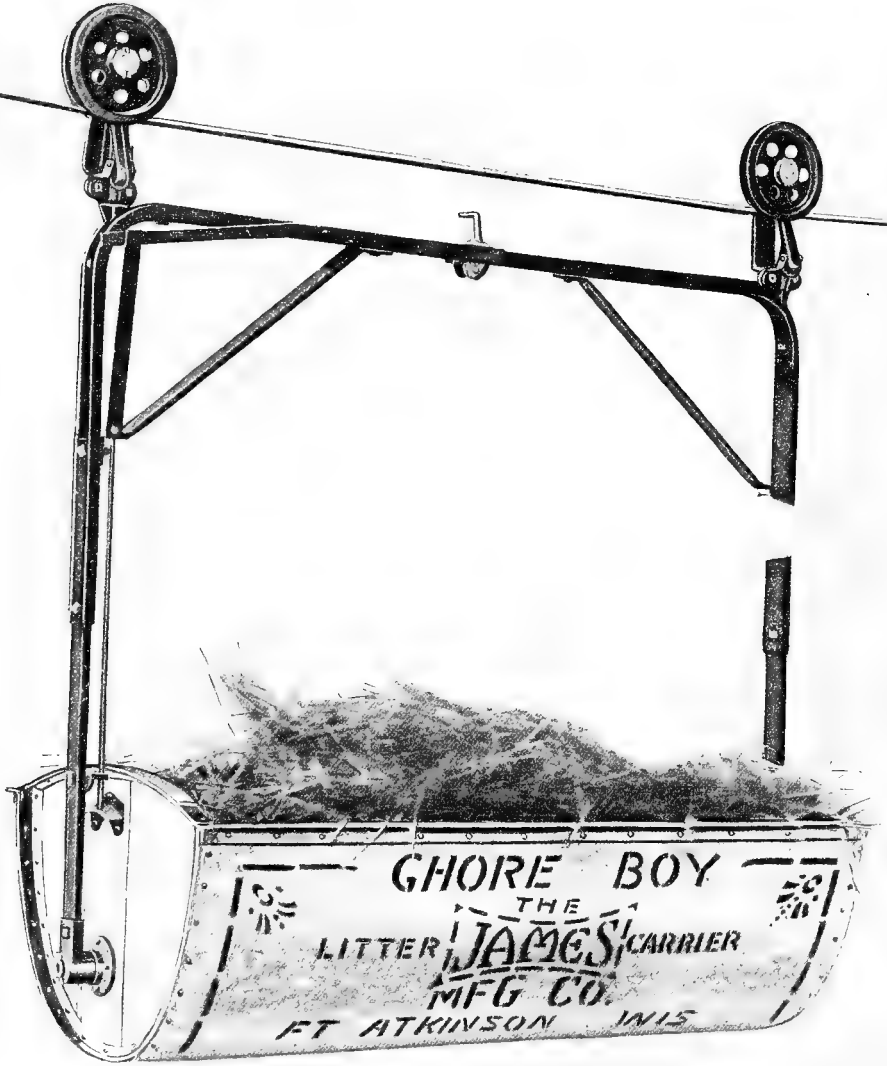
This track support is furnished in two styles.

**STEEL SUPPORT:** Made in two sizes. One, constructed of  $2\frac{3}{8}$ -in. O. D. galvanized pipe, the brackets which hold the supporting rods being fastened to the barn with  $\frac{3}{8}$ -in. lag screws. The supporting rods are  $\frac{1}{2}$ -in. diameter. Struts are  $2\frac{3}{8}$ -in. O. D. galvanized pipe, fastened to the barn with malleable flanges and  $\frac{1}{2}$ -in. lag screws. The other, made of  $1\frac{7}{8}$ -in. O. D. pipe, painted, with  $\frac{1}{16}$ -in. lag screws.

No threaded fittings are used, the pipe frame being put together with clamps of best malleable. The entire structure can be erected with no tools excepting a hammer and a wrench. Blue prints showing details and prices furnished on application.

**WOOD SUPPORT:** A similar structure can be built of wood, in which case we furnish only the supporting rods of  $\frac{1}{2}$  in. diameter, with brackets and lag screws for attaching to barn and the wood frame.





GHORE BOY  
THE LITTER CARRIER  
JAMES MFG CO.  
FT ATKINSON IN 15

## James "Chore Boy" Carrier

(For Rod Track)

While the demand is more and more for the James I-Beam Track Carrier, with a swinging crane, there is some call for moderate priced rod track carriers for use in small barns where only a few head of stock are to be cared for.

The James "Chore Boy" meets this need combining as it does all the desirable and essential features necessary for a rod track outfit at a moderate price.

By putting up the outer end of the track at the proper angle the carrier, when loaded, can be made to run out, dump its load at the desired point, and return automatically to the barn. A vigorous shove at the barn door is all that is required.

The tub of the carrier is dumped by means of a trip block, which can be placed at any desired point on the track. When the trip strikes this block it unlocks the tub, the tub dumping either way, according to which side is loaded the heavier. An ingenious device makes the trip positive, so that tub is always certain to dump. Tub is so shaped as to be self cleaning.

The "Chore Boy" cannot jump the track, being prevented by automatic keepers on the tracker wheels. The keeper, however, unlocks as it strikes a curve, allowing tracker wheel to swivel; the other wheel remaining on the track is locked rigid and parallel with the rod track, thus overcoming the tendency to run sideways and bind. This position is maintained until wheel strikes curve, then keeper unlocks and allows the wheel to swivel.

Each tracker wheel contains ten long, cold rolled steel bearings, producing a bearing almost frictionless.

The bail is adjustable, so that the tub can be lowered or raised.

The carrier can be adjusted to take either a left or right hand curve, it being only necessary to lift the wheels from the track, one at a time, and swivel them around.

### SPECIFICATIONS

**STEEL END TUB:** Of 18-gauge galvanized steel. Built on a frame work of angle iron,  $1 \times 1 \times \frac{1}{8}$  in. at side and end edges; end of tub reinforced steel plate  $3\frac{1}{2} \times \frac{1}{8}$  in., well riveted, all rivets galvanized and are  $\frac{3}{16}$  in. except corner rivets, which are  $\frac{1}{4}$  in. Gudgeon support is riveted to the two thicknesses of steel on end of tub. Tub is self-cleaning.

**BAIL:** Of channel steel with heavy bail braces. Bail is adjustable.

**GUDGEON:** Attached to steel end tub, riveted through the two thicknesses of steel.

**TRACKER WHEELS:** Gray iron, lathe turned, large diameter, mounted in swiveled tracker wheel frames. Tracker wheel axle of steel with eleven long cold rolled steel bearings.

**TRACKER WHEEL FRAME AND KEEPER:** So constructed that wheel cannot jump the track.

**LATCH AND TRIP:** Tub dumps automatically when trip strikes the trip block.

Trip block of bar steel  $1 \times \frac{1}{4}$  in., can be locked at any desired point on the track.

**BEARINGS:** Bearings that get much wear in operation are machined, to assure accurate fit and smooth surface; this reduces friction, lessens wear, increases ease of operation and adds greatly to life of carrier. Bearings that are left merely cored as they come from the foundry, are covered with sand roughness, which cuts into metal like so much emery. Hence the great importance of machined bearings.

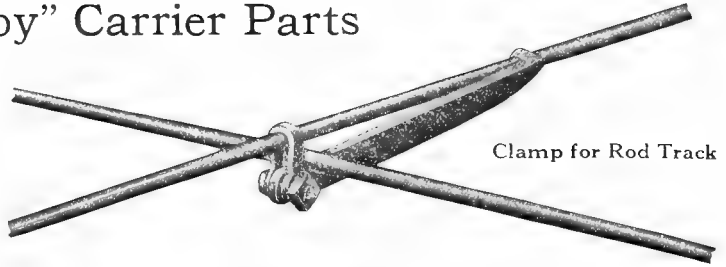
**CAPACITY:** Is  $41\frac{1}{2}$  inches long, 24 inches wide, 15 inches deep, and measures approximately  $4\frac{1}{2}$  bushels.

**WEIGHT:** Approximately 80 pounds. To be used on No. 0000 rod track.

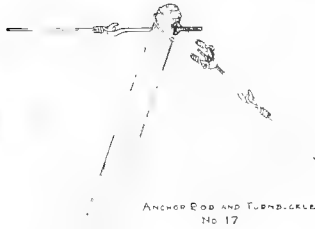
# "Chore Boy" Carrier Parts

Six 0 Basic Steel Wire,  
cut to length.

Four 0 Basic Steel Wire,  
cut to length.



Clamp for Rod Track



ANCHOR ROD AND TURNBUCKLE  
No. 17

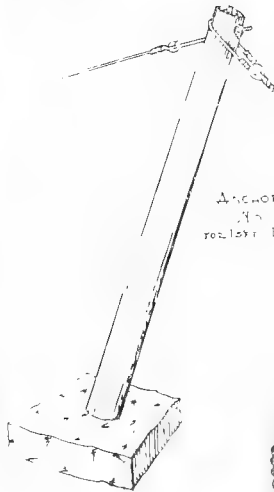


Spring Track Suspender, No. 3

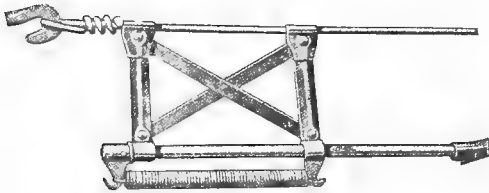


Rigid Track Suspender, No. 4

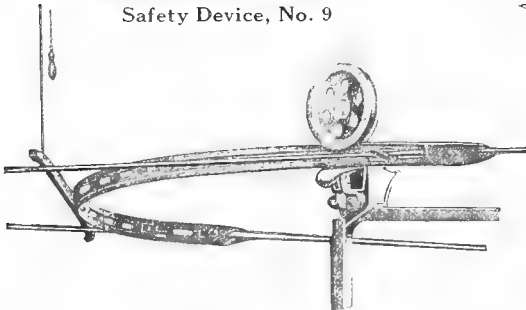
Tension Bolt  
3/4" x 29"



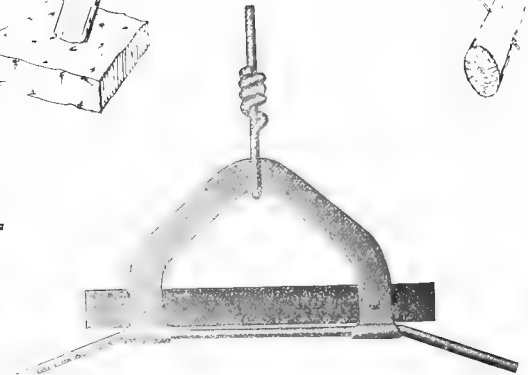
ANCHOR ROD  
No. 18  
REGULATED FOOT



Safety Device, No. 9

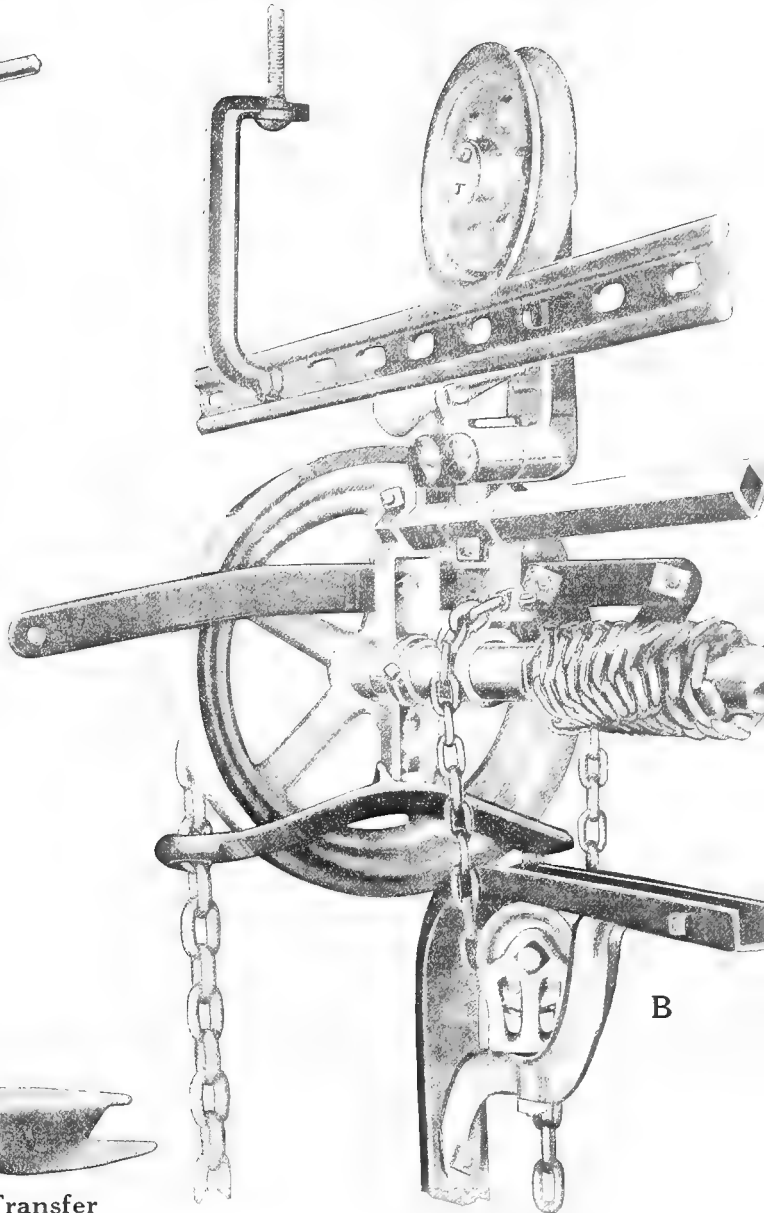
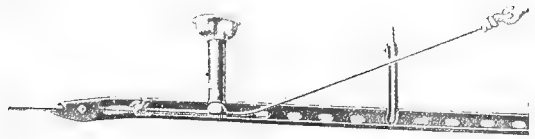
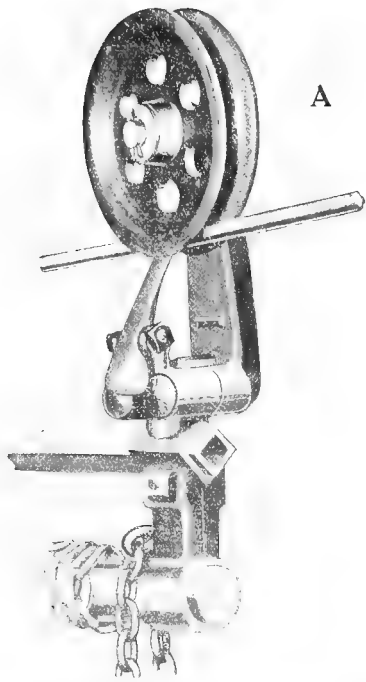


Switch or Curve, No. 6

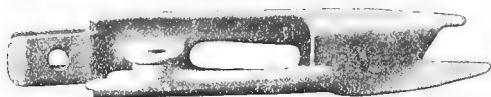


Angle Bracket for Rod Track

# Combination Carrier



**Adjustable Track Strut**  
See illustration above

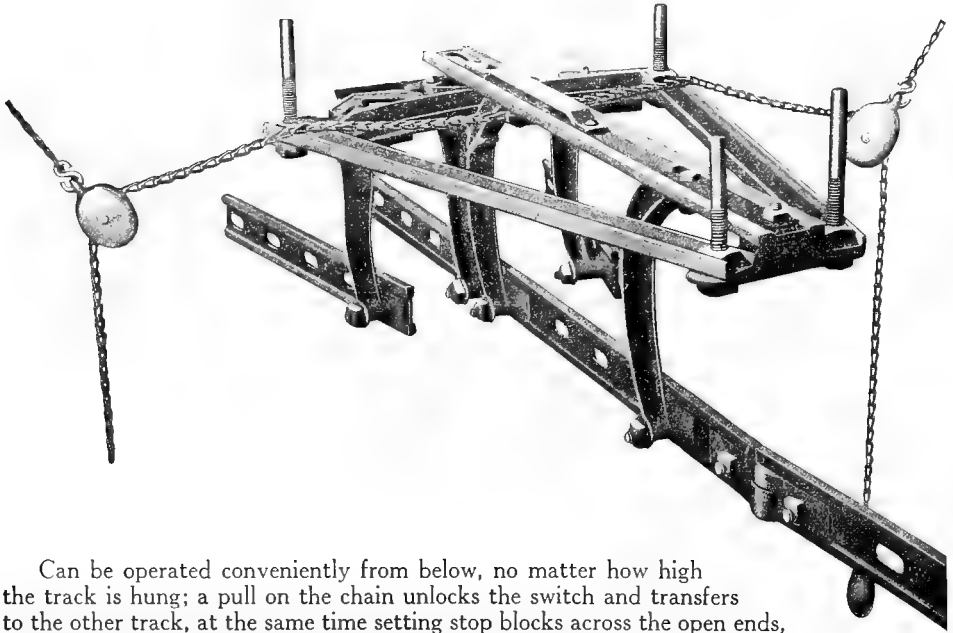


**Combination Track Transfer**

Illustrations A and B show clearly the operation of the keeper which prevents ju the track; the absolute control clutch and brake; and the easy running tracker The winding shaft is cold rolled, solid steel shafting.

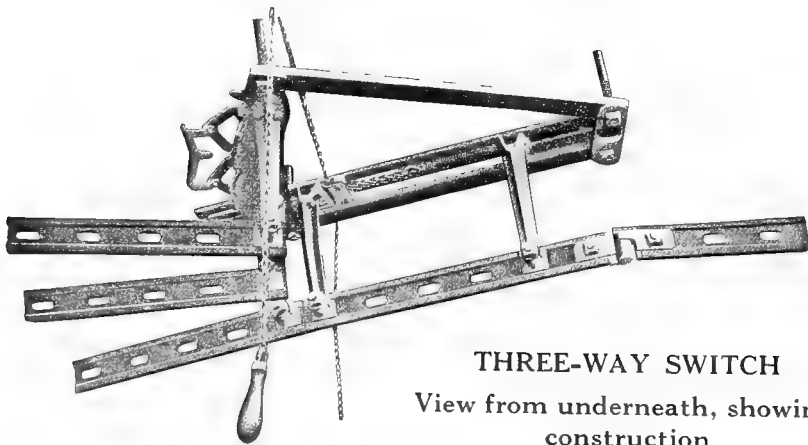
# Safety Switches for Combination Carrier

(PATENTED)



Can be operated conveniently from below, no matter how high the track is hung; a pull on the chain unlocks the switch and transfers to the other track, at the same time setting stop blocks across the open ends, there is never any possibility of a James Carrier running off the track. When the pull on the chain is released, the switch automatically locks in place.

The James Safety Switch is the simplest, surest and easiest in operation; being constructed of best iron, it is strong and durable. Either two-way or three-way switches are furnished; both operate in the same manner.



## THREE-WAY SWITCH

View from underneath, showing construction

## The James Combination Carrier

(For I-Beam and Rod Track)

This carrier has back of it all the quality, reputation and experience that have made James Carriers and James Equipment famous and successful.

For the smaller barns, it is one of the most valuable and most sensible labor savers ever put on the market, and is proving a big winner. It is not, however, adapted to the larger barns, say fifteen head of stock or more, because the capacity of the tub is limited by the strength of the anchorage of the rod track.

The James Combination Carrier has all the advantages of the I-Beam track inside the barn—the celebrated James track that can be bent to any curve without the use of heat, doing away with the expense for special curves; the “button-on” hangers that make the outfit easy to erect, a tub that can be quickly dropped to the floor for loading, and that “stays put” on the track while being filled—track can’t sag, hence the carrier moves only when you push it; and other features that make barn cleaning easy.

This carrier also has all the advantages of the rod track outside the barn. You can stand at the barn door, give the carrier a shove—it runs out, dumps at the desired point and returns automatically to the barn. Saves walking through the wet yard and snow.

The tub dumps to either side, giving you more dumping space and making it more convenient to dump into wagon or spreader. Latches at the ends of the tub, lock and unlock simultaneously; work surely and easily; and are protected so they will not clog with manure.

The trip block which dumps the tub can be locked to the track at any desired point. When the trip strikes this block, the tub dumps to whichever side is loaded the heavier. An ingenious device makes the trip positive, so that dumping is certain.

Carrier returns automatically to the barn when empty.

The long life tub is the same in materials and construction as the “Big Boy” carrier tubs, described on page 229 the only difference being in size.

Heavy straight link lifting chain is used, this being strongest and best adapted to the purpose. It is attached to the center of the cold rolled, solid steel shaft, so that in winding up it forms a very open spiral, preventing rubbing and wear. No cable to wear out and break.

The carrier is very easy running because of the narrow tread on both the I-Beam track and the rod track, and because each tracker wheel contains eleven long, cold rolled steel bearings, making it almost frictionless.

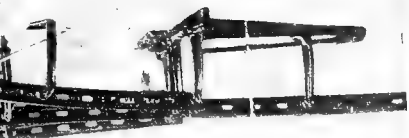
Whether the carrier is on the rod track or on the I-Beam track, or passing from one to the other, it can’t jump off. The ingenious keeper makes that impossible. There is but one way to get it off the track and that is by deliberately lifting it off.

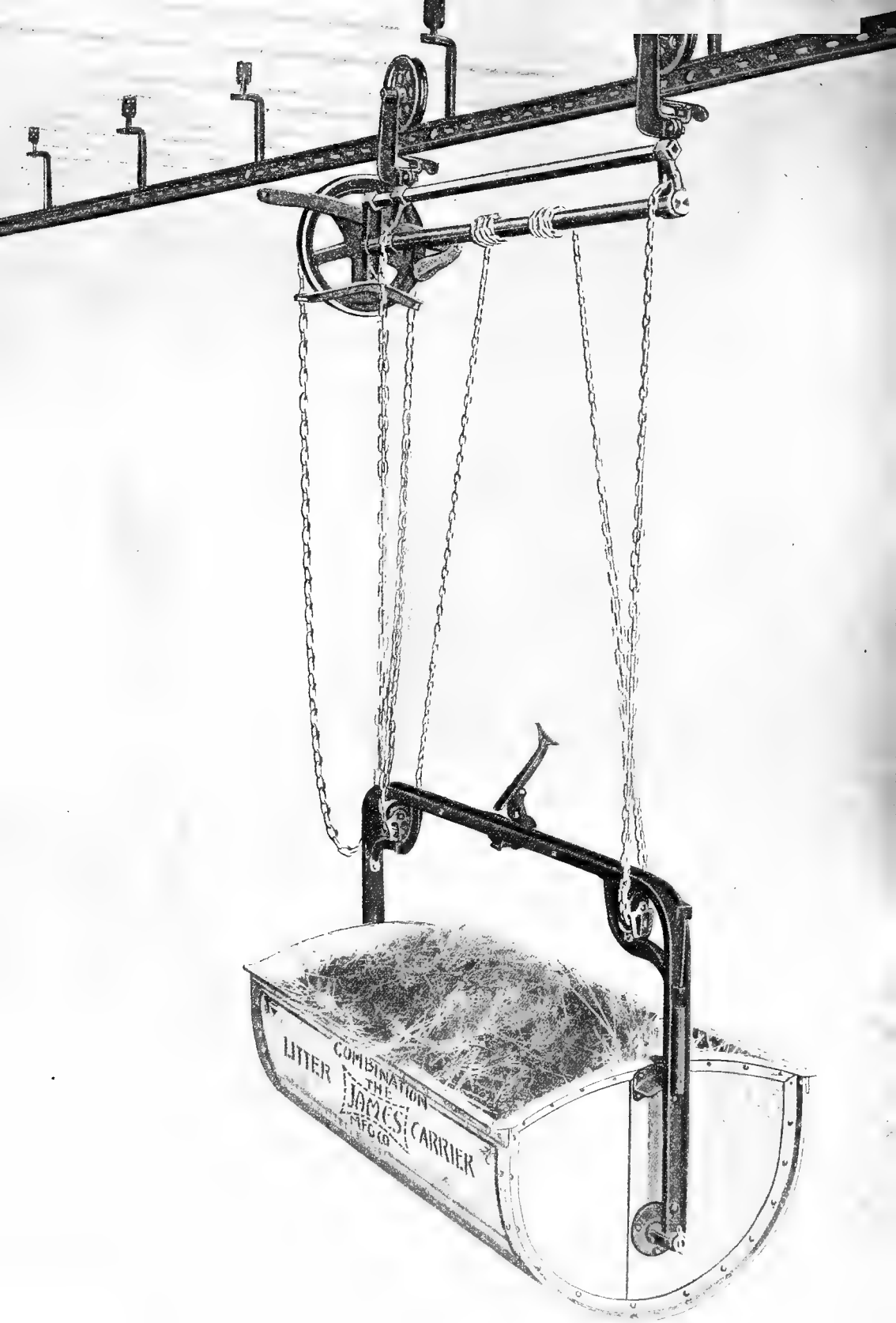
The direct hoist is used; so geared as to raise the load in the shortest time possible without undue effort.

The Absolute Control Clutch and Brake described on page 231 is a most important part of the Combination Carrier. Turn back to that page and learn its advantages.









# James Combination Litter Carrier

(PATENTED)

## SPECIFICATIONS

**TUB:** Constructed of 18-gauge galvanized sheet steel. Built on a framework of angle iron; angle iron at side edges being 1 x 1 x  $\frac{1}{8}$  in.; at the ends 1 x 1 x  $\frac{1}{8}$  in.; end of tub reinforced with steel plate  $3\frac{1}{2}$  x  $\frac{1}{8}$  in. Well riveted, all rivets galvanized and are  $\frac{3}{16}$  in.; except corner rivets, which are  $\frac{1}{4}$  in. Gudgeon support is riveted to the two thicknesses of steel on end of tub. Tub is self-cleaning.

**PERFECT CONTROL CLUTCH AND BRAKE:** Of malleable and bar steel. For explanation of operation see page 231.

**HOIST:** Direct type; hoist wheel is 11 in. in diameter; raises tub quickly; made of best iron and steel.

**CHAIN GUIDES:** Malleable. Prevent hand chain running off hoist wheel.

**SHAFT:**  $1\frac{1}{4}$ -in. cold rolled solid steel shafting, same as used in factories for line shafting. (See page 235.)

**LIFTING CHAIN:** Straight link chain, tested for several times the load it will have to carry. Three-point suspension; in winding up forms an open spiral, preventing rubbing and wear. (See page 235.)

The distance from the top of the tracker wheels to the bottom of the Combination Carrier Tub, when raised, is 44 inches; when lowered the distance is 8 feet.

**TRACKER WHEELS:** Made of gray iron. Large diameter. Mounted on swiveled tracker wheel frames. Tracker wheel axle of steel with eleven long cold rolled steel bearings.

**TRACKER WHEEL FRAME AND KEEPER:** So constructed that wheels can not jump the track whether on rod track, I-beam track or passing from one to the other. (See page 233.)

**BAIL:** Channel steel, reinforced by corner bail braces.

**LATCH AND TRIP:** Latches at both ends, locking and unlocking simultaneously. Tub dumps automatically when trip strikes the trip block; trip block, of malleable iron locked to cable with a set screw 1 x  $\frac{1}{4}$  in., can be locked at any desired point on the track.

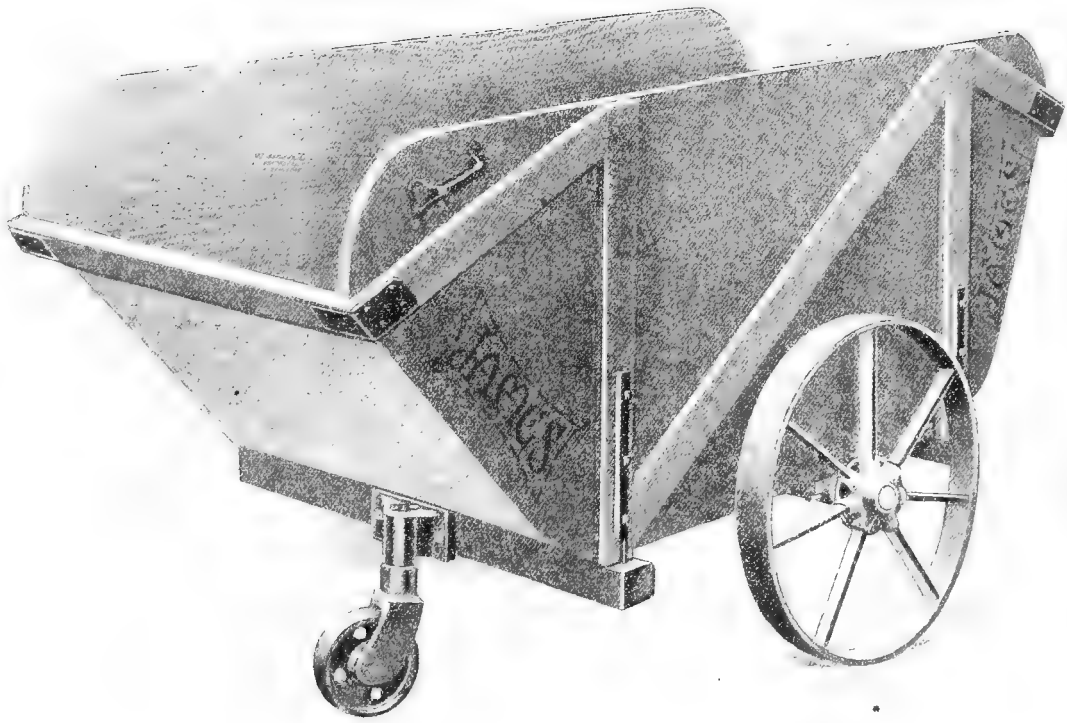
**BEARINGS:** All bearings that get wear in operation are machined, to assure accurate fit and smooth surface; this reduces friction, lessens wear, increases ease of operation and adds greatly to life of carrier. Bearings that are left merely cored, as they come from the foundry, are covered with sand roughness, which cuts into metal like so much emery. Hence the great importance of machined bearings. (See page 228.)

**CAPACITY:** Tub is 40 inches long, 22 inches wide, 16 inches deep, and measures approximately 5 bushels.

**WEIGHT:** Approximately 145 pounds.

No. 000000 rod track must be used with the combination carrier.

10115



# The James Feed Trucks

## SPECIFICATIONS

### 16-Bushel Truck

**BOX:** Constructed of clear selected lumber, strongly reinforced by side cleats. Bottom is No. 18-gauge galvanized sheet steel. Extreme length 68 inches, width 26 inches, height 24 inches. Ends slanting to make shoveling easy. The weight of the feed box is equally balanced on the wheels so that when filled the truck can be run along any reasonably smooth floor or walk with but little effort.

**WHEELS:** Arrangement of the wheels is such that the truck can be turned around in a space of 75 inches in diameter.

**MAIN WHEELS:** 20 inches in diameter, 2-inch face. End wheel anti-friction swivel, 6-inch diameter, 2-inch face.

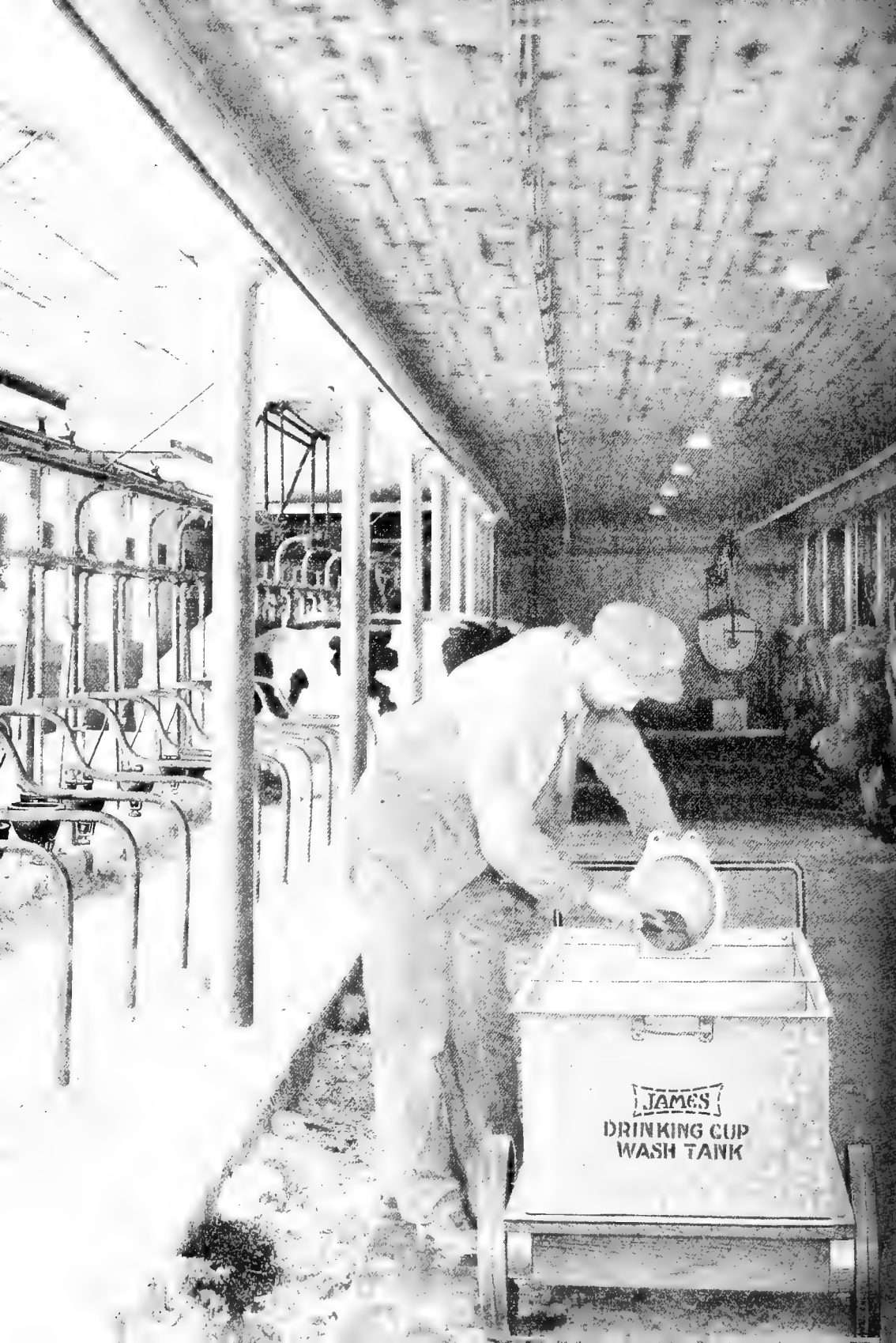
**AXLE:** 1-inch solid cold rolled steel, with set collars; axle and wheels run freely. Extreme length of shaft 32 inches.

**BEARINGS:** All bearings that get wear in operation are machined, to assure accurate fit and smooth surface; this reduces friction, lessens wear, increases ease of operation and adds greatly to life of carrier. Bearings that are left merely cored, as they come from foundry, are covered with sand roughness, which cuts into metal like so much emery. Hence the great importance of machined bearings.

**CAPACITY:** 16 bushels.

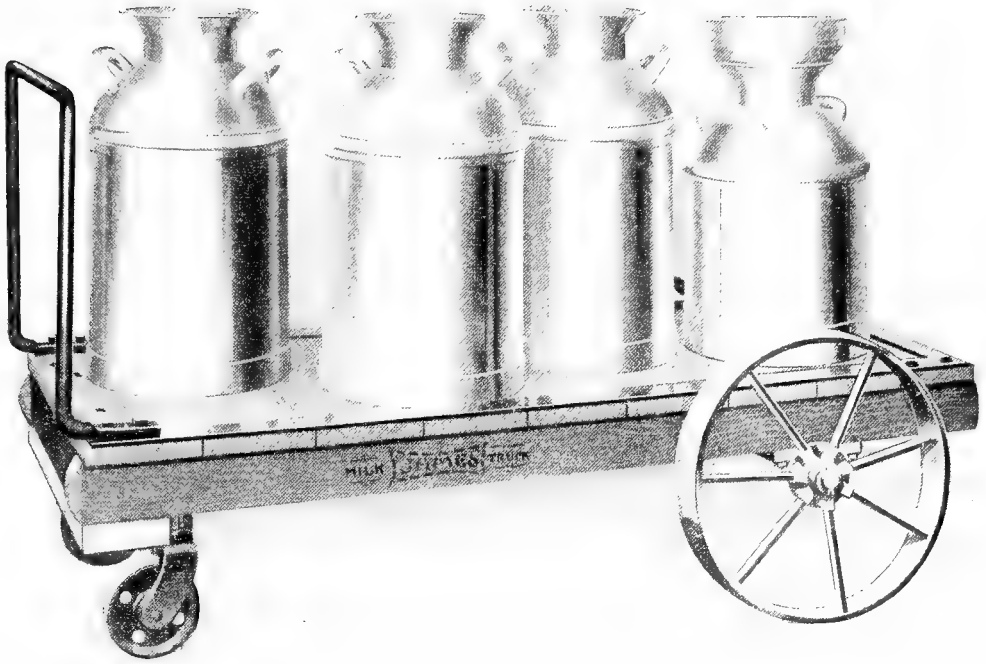
**WEIGHT:** Approximately 200 pounds.

Can be made special in other widths to meet conditions, if alleys or doors are too narrow.



**JAMES**  
**DRINKING CUP**  
**WASH TANK**

## James Milk Can Truck SPECIFICATIONS



FRAME: Best hard maple.

FLOOR: Clear birch,  $\frac{7}{8}$ -inch thick, reinforced with steel straps to prevent wear.

WHEELS AND SWIVEL: Gray iron, heavy, to stand all shocks. Drilled for oil holes. Now made with four wheels, instead of three as illustrated.

AXLE: 1-inch diameter, mild steel.

HANDLE:  $\frac{7}{8}$ -inch diameter, mild steel.

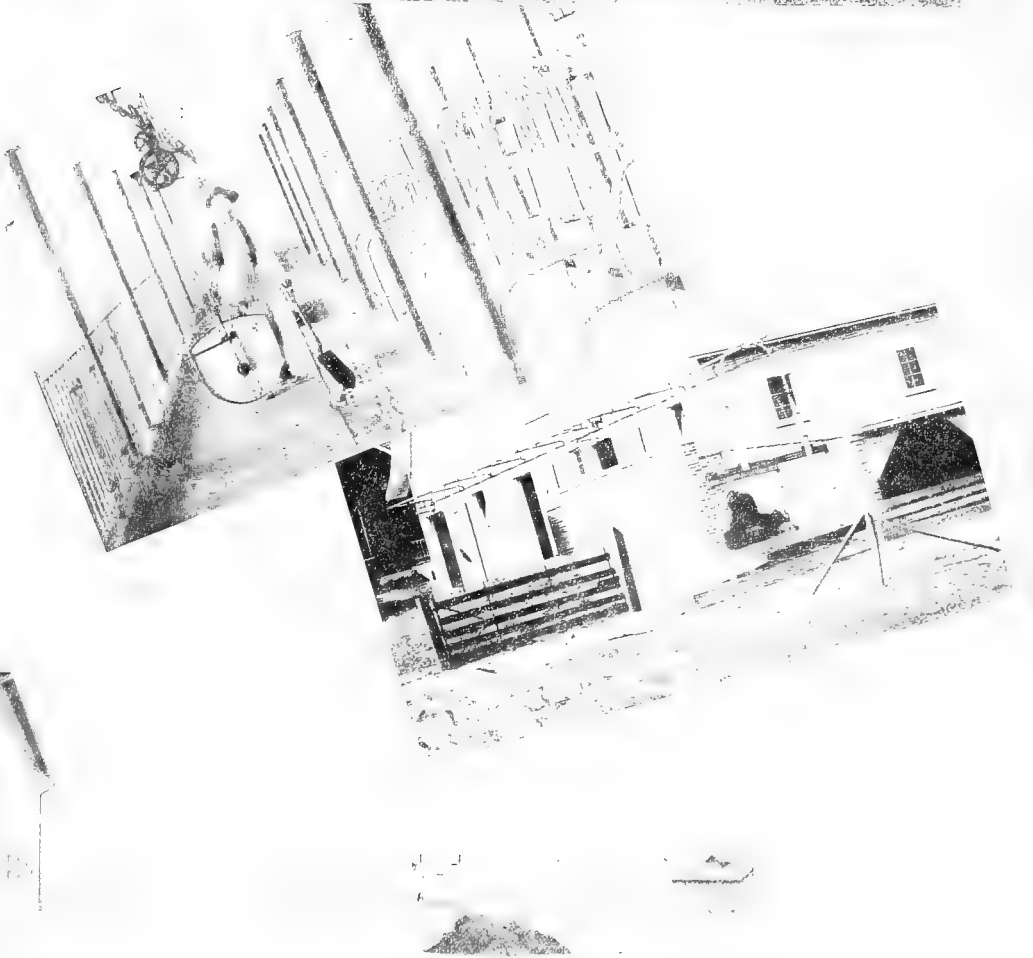
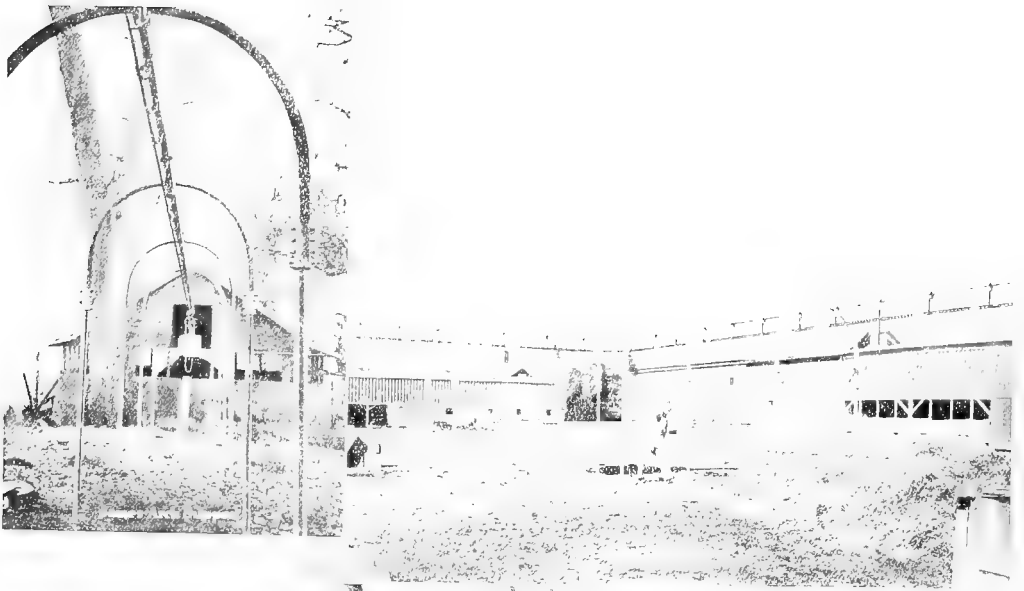
## Drinking Cup Wash Tank SPECIFICATIONS

To be used on truck shown above.

Tank made of 18-gauge galvanized sheet steel, strongly reinforced at the top with  $\frac{7}{8}$ -in. x  $1\frac{3}{8}$ -in. x  $\frac{1}{8}$ -in. galvanized angles; all joints securely riveted and soldered both inside and outside.

Divided into two water tight compartments  $17\frac{3}{4}$  inches long, 21 inches wide, 13 inches deep and  $34\frac{1}{2}$  inches long, 21 inches wide, 13 inches deep.

Over all dimensions of tank are  $24\frac{3}{4}$  inches wide,  $53\frac{3}{4}$  inches long, 13 inches high.



James Combination Carrier



# The James Ventilators\*



AIRYMEN, generally, realize the full importance of pure air to the herd, because they know the condition in which an unventilated stable is found on a cold morning.

They know the air in such a barn is bad, and that the damp, frosty barn is an unhealthy place for the cattle.

Not only is such a condition injurious to the stable itself, affecting the walls, rafters, ceiling and equipment, causing wood to rot and metal to rust; but most important of all is the injurious effect of the lack of fresh air on the vitality of the animals.

Without pure air, they are unable to get the full benefit of their food, the milk production is lowered and the cattle are more subject to diseases, such as tuberculosis and pneumonia. The loss of stock in the United States during one year from tuberculosis alone amounted to fourteen million dollars.

The dairyman works hard for six or seven months of the year preparing expensive food in the way of hay and grain for winter use. He cannot afford to feed this expensive food during the winter months and fail to provide the fresh air necessary to properly digest this food and turn it into milk.

A furnace can be filled with expensive fuel, the fire started and a forced draft used, but if the air forced into the furnace does not contain oxygen, the fuel will not burn properly and much will be wasted.

A similar action takes place in the animal's body and unless oxygen is provided by bringing fresh air into the barn, the animal will waste feed just as the furnace would waste fuel, and the milk production will be reduced.

To provide fresh air, a good ventilator is necessary—the ventilator is one of the most important items of barn equipment. But the ventilator alone cannot furnish the pure air.

Ventilation depends on the proper working out of certain scientific rules, and if not correctly done, the system cannot give the best possible results.

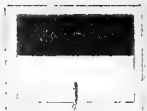
The system of ventilating must vary to meet the particular conditions in each barn or building.

The information given in this book is of a general nature, the blue prints shown in the fore part being intended merely as examples, and without any thought that they apply to all cases.

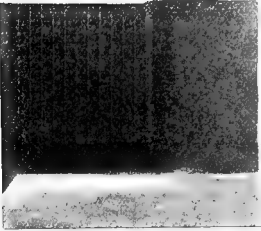
If you purchase James Ventilators, we will, without any extra charge, design a system of ventilation to meet your individual requirements, furnishing blue prints showing the proper size and location of outtake and intake flues, with details of how they should be constructed to obtain satisfactory results.

---

NOTE: Pages 53-81 on Ventilation should be studied before reading this section on "The James Ventilator."



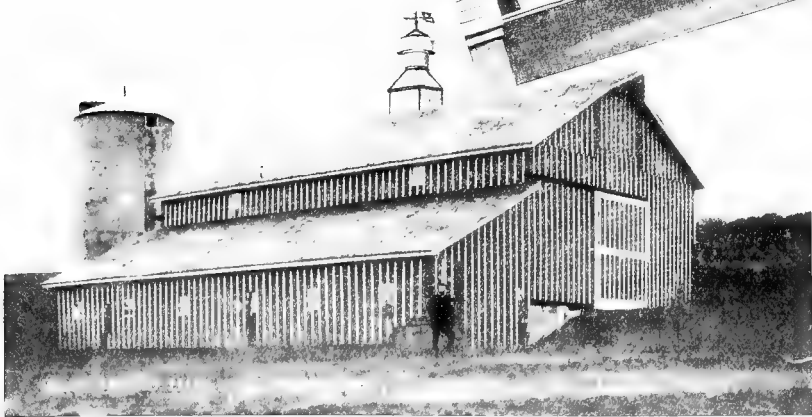
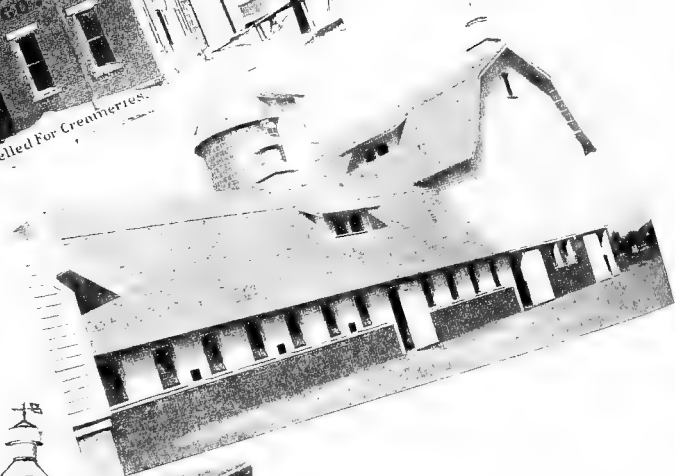
Note Opening  
in Outtake at Ceiling.



Outtake  
Flue.



James Ventilators Unexcelled For Greenhouses.



The dairy barn, of course, is not the only building that requires ventilation. Pure air is just as important in horse stables, hog houses, poultry houses, homes, factories, moving picture theatres, and wherever else human beings or animals may be brought together within the walls of a building. It is needed also for tobacco houses, and buildings of like nature.

To meet these varying conditions, we make James Ventilators in a variety of sizes and of two general types—Solid Hood and Revolving Hood.

The James Ventilator with the solid hood is just as efficient as any ventilator other than the James now on the market for use on dairy barns; indeed, it is more efficient than most of them.

The most efficient type, of course, is the James Ventilator with the revolving hood, because it offers the least resistance to the outflow of foul air, provides greater capacity at the outlet openings, and because it takes advantage of the suction power of the wind to exert a pull on the foul air in the outtake flue.

Actual tests by a competent engineer have shown that the James Ventilator with revolving hood gives 65 per cent better ventilation than the usual wooden cupola and 30 per cent better ventilation than the ordinary ventilator for dairy barns.

This great superiority of the James Revolving Hood Ventilator is due to these three James principles: (1) construction that offers the least possible hindrance to the outward flow of foul air; (2) increasing the outlet space for outflowing air, by addition of outlet space provided by revolving head; (3) the application of *suction* at the proper point to help pull the foul air out.

How these three important principles are combined with the best features of other types of ventilators, at the same time avoiding their disadvantages, can perhaps best be shown by a brief discussion of the principles on which ventilators are constructed, and the reasons why certain features are essential.

A ventilating flue is much like a chimney. But while the same principles apply to both, with a ventilating flue it is necessary to go a step or two further.

A ventilating flue, like a chimney, should be as straight as practicable, higher than the building, of ample size; and airtight to "draw well."

### How Ventilating Flue Differs from Chimney

The ventilating flue, however, cannot be left without a cap, as may oft-times be done with a chimney, and a little thought will make the reason clear.

Rain and snow falling into the chimney do no harm, for the heat is sufficient to vaporize the moisture and the upward current carries it out again.

With a ventilating flue, however, there is not sufficient heat for this purpose, and hence, even were there no other reason, a ventilating flue would need to be capped to protect against the weather.

The foul air, in order to leave an outtake flue not capped with the right type of ventilator, would often have to fight its way directly against counter

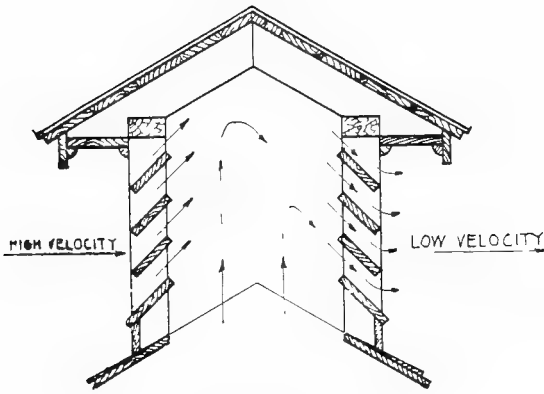


Fig. 5  
Wooden Cupola

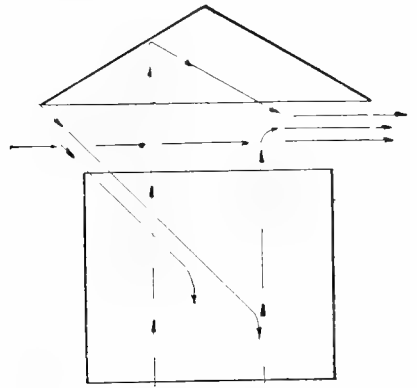


Fig. 6  
Metal Cupola—Cap is too high; wind and rain blow in

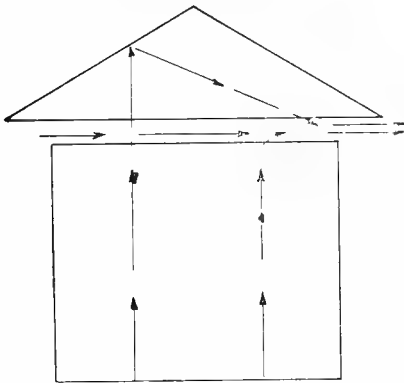


Fig. 7  
Metal Cupola—Cap is too low; outflow of air is choked down

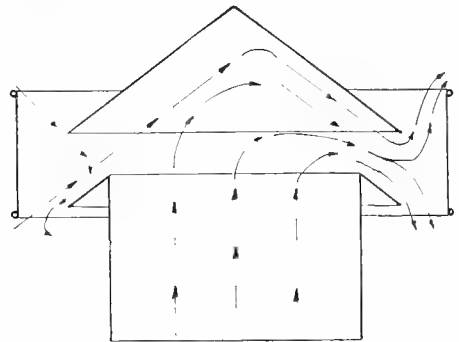


Fig. 8  
Metal Cupola with Storm Band

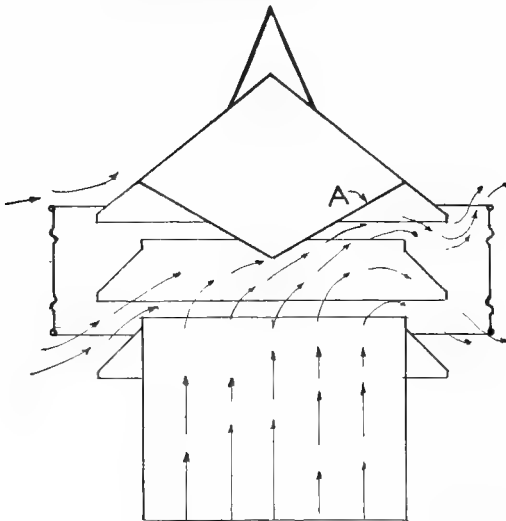


Fig. 9  
James Solid Hood Ventilator

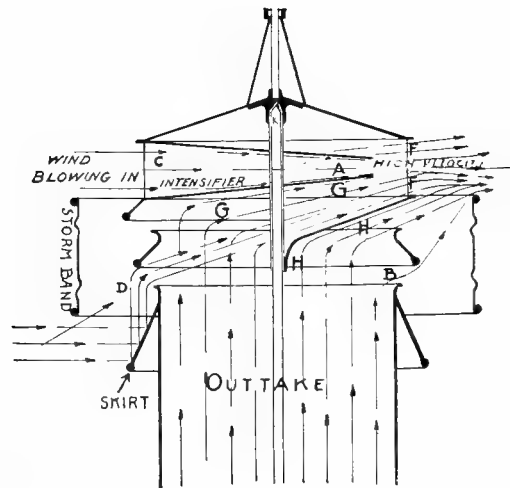


Fig. 10  
James Revolving Hood Ventilator

currents. These outer currents, being stronger, would force the foul air back, down the flue. This would reverse the ventilating system, removing the warmer, purer air instead of the colder, foul air.

The old-fashioned wooden cupola was intended more as an ornament to the barn rather than for the more practical purpose of aiding ventilation, although in building it an attempt was made to keep out the weather.

The wooden cupola, however, seriously interferes with the outflow of air. Usually the total area of the outlet space between the louvres is less than the cross section area of the flue, thus choking down the flow of air.

Besides this interference with the air flow, the air currents, to escape, must make a very sharp turn, as indicated by the arrows in Fig. 5, opposite page, the flow of air almost turning back upon itself.

Then, too, whirling or eddying currents are caused when the wind blows into the cupola and comes into conflict with the upward current of warm air, hindering still further the outflow of foul air.

All together, these restrictions upon the free escape of the air make proper ventilation impossible with the old-style wooden cupola.

The ordinary, locally made metal cupola, is also unsatisfactory, not alone because it is usually made far too small for the amount of foul air to be removed but also because when made weatherproof, the cap must be placed too low, as shown in Fig. 7, slowing down the outgoing current of air. Or if the cap is placed high, the rain and snow and wind drive down the flue, as in Fig. 6.

Both these types of cupolas shown in Figs. 6 and 7 have the fault present in the wooden cupola—that of checking the outflow of air by having to make a sharp turn and by the eddies created when the wind entering from outside combats the upward flow of air in the flue.

To prevent the troubles caused by the wind blowing into the flue, a storm band is ordinarily used as shown in Figs. 8 and 9. This keeps out snow and rain and makes the ventilator almost proof against the wind.

In ventilators other than the James, however, the storm band hinders the outflow of air by forcing the air current to make *two* sharp turns.

Also, the upward current striking the top of the ventilator causes eddies, choking the flue and interfering with the free escape of the foul air. A little wind gets by the under side of the storm band and this, too, creates eddies.

With the James Revolving Hood ventilator, however, the outgoing foul air has a *free outlet* unimpeded by excess friction caused by right-angle turns, by eddies or by being forced back upon itself. (See Fig. 10.)

This is to a large degree true of the James Solid Hood Ventilator; upward moving foul air strikes an upward sloping surface "A", Fig. 9, page 276. In the James ventilator with revolving head upward sloping surfaces at "CG" and "HH" (Fig. 10, page 276), turn the air gently outward and upward.

This makes clear how, in James ventilators, offering the least possible hindrance to outflowing foul air is used to increase the efficiency.

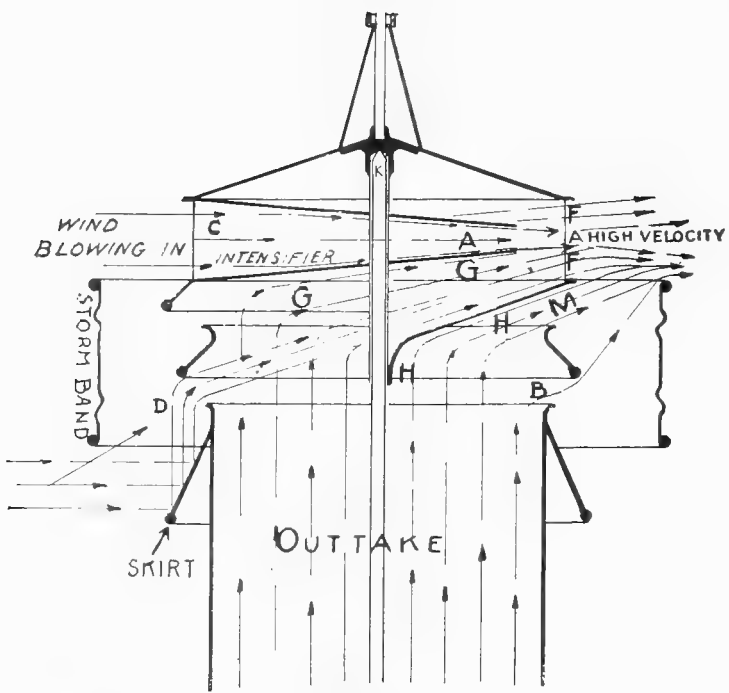


Fig. 2

**James Ventilator with  
Revolving Hood**

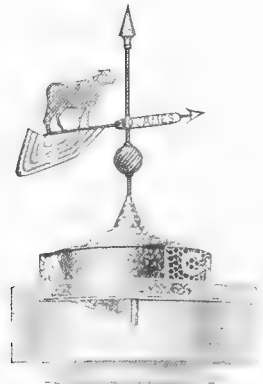
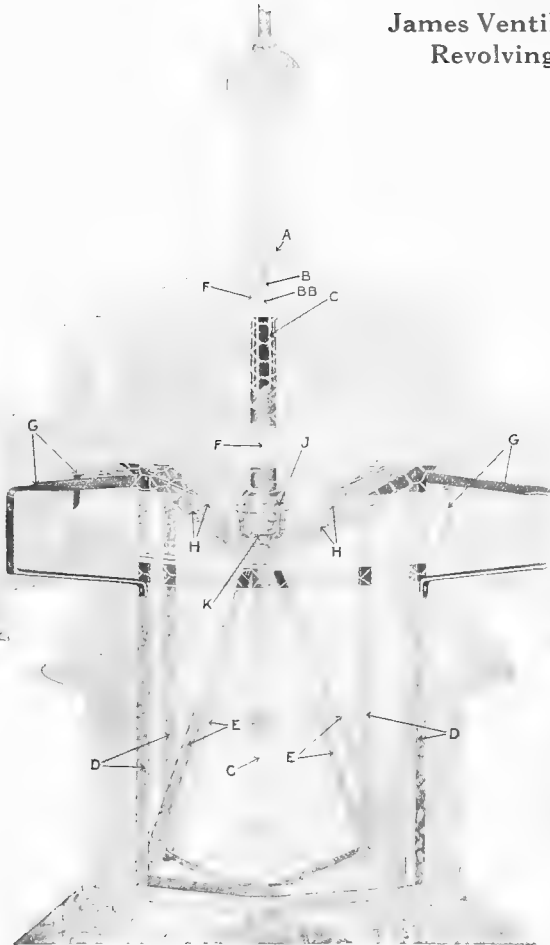


Fig. 2

## The James Ventilator with Revolving Hood

(PATENTED)

The revolving hood principle adds greatly to the ventilator's capacity to remove foul air.

A study of Fig. 2, page 278, will make clear how the air in one-half of the outtake flue is removed through the usual space between louvres (points "M" and "B"), while the air from the other half of the outtake is removed through the additional outlet space of the revolving head at the point marked "FF". In other words the outlet space has been enlarged as compared with the ordinary type of ventilators.

The James ventilator with revolving hood also takes advantage of the power of suction—it helps pull foul air out of the barn and brings fresh air in.

The top of this Ventilator (the dark portion of Fig. 4) turns on a hardened steel point, like a compass ("K" Fig. 2). The vane "B" (Fig. 4) keeps the opening "C" (Figs. 2 and 4) always toward the wind.

The tapering construction of the "intensifier" ("C-A," Figs. 2 and 4) "speeds up" the wind as it passes through, so that it leaves "A" at high velocity. This creates *suction* in the vicinity of "FF" (Fig. 2) exerting a powerful pull on the air in the outtake flue.

### An Interesting Test—Try It

Take a sheet of paper about the size of this page. Roll it in the form of a cone having a diameter of about one-fourth inch at the small end and one inch and a half at the big end.

First, put the little end in your mouth and blow, holding one hand about six inches in front of the big end. The current of air can hardly be felt.

But now turn the paper cone the other way around. Put the big end in your mouth and blow, holding one hand about six inches in front of the little end. A strong current of air will be felt.

In just the same way, the wind passing through the tapering intensifier in the James Ventilator with revolving hood increases in speed and leaves with high velocity at point "A" (Fig. 2).

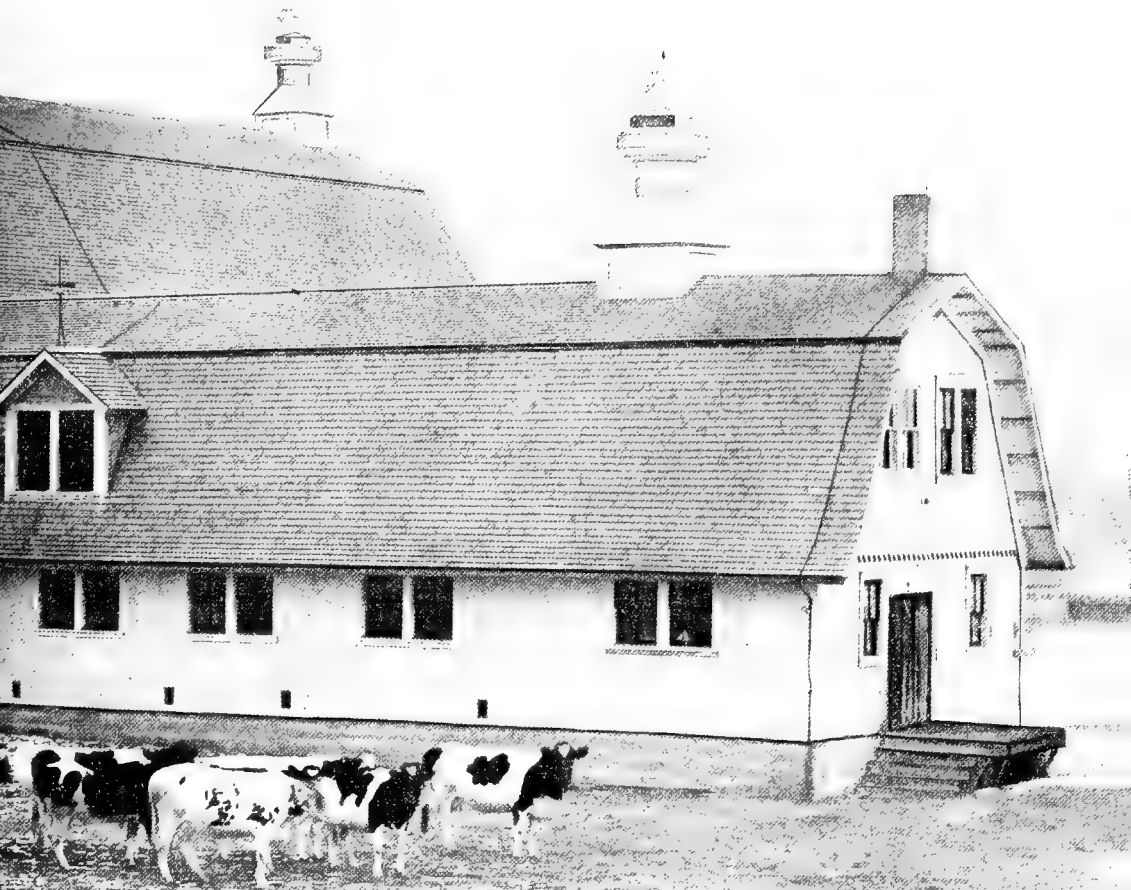
If you are a smoker, here is another easy experiment which will further illustrate this *suction* principle.

"Hit up" your pipe or cigar until you have a good thick cloud of smoke. Then pucker your lips and blow vigorously into the center of the smoke cloud. Not only the smoke directly in the path of the current of air is removed, but the surrounding smoke is also sucked into the current and carried away.

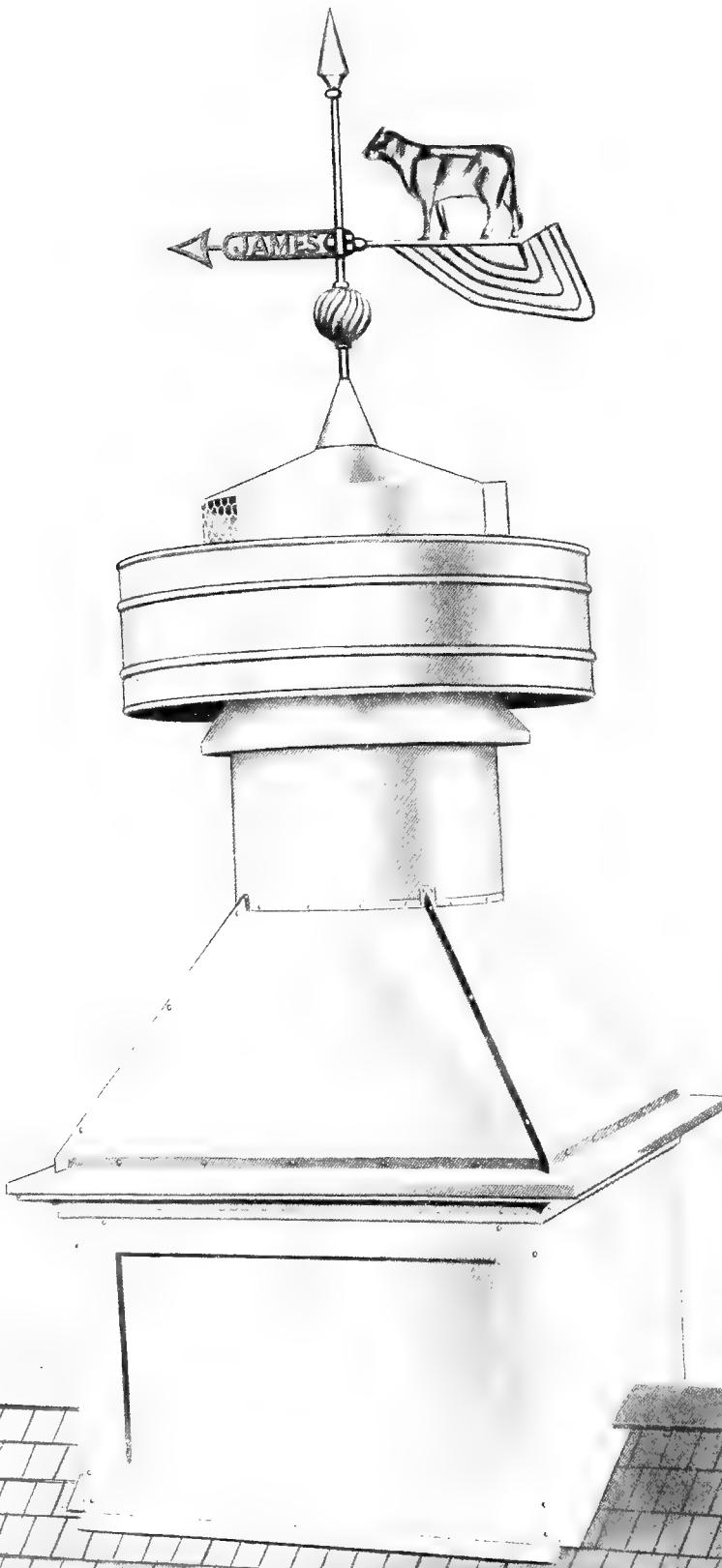
Just so the higher velocity at point "A" creates suction, carrying the surrounding air with it. As this surrounding air is warm moist air from the outtake flue, the air removed by the suction is constantly replaced by more air from the flue, thus speeding up the outflow of foul air and increasing the amount removed in a given time.







Experimental Barn  
Manufacturing Co.



It is very much the same principle as that of the ejector in a steam engine.

Another illustration in point is the suction created by the rapid movement of a train or an automobile. Watch an express train passing by and you will see a cloud of dust and light weight-refuse, such as scraps of paper following.

In the same way the velocity of the air leaving the intensifier at "A" carries the surrounding foul air with it.

The foul air removed from the barn is, of course, at once replaced with pure air from out of doors, through the fresh air intakes.

The slightest breeze will turn the ventilator top, and a very light breeze blowing through the intensifier will create some suction.

Aviators have found that even when there is no wind or air movement apparent to a man on the ground, there are nevertheless currents of air in constant motion. Hence the James Revolving Hood Ventilator is always at work helping to remove foul air.

Every system of ventilation depends for its efficiency on the thoroughness with which foul air is removed and fresh air brought in to take its place.

The motive power on which other systems depend for a continuous upward current in the foul air flues, is a difference in temperature between the air in the stable and the air out of doors.

Or in other words, they depend upon the air in the stable being lighter (warmer) than the outside air.

The air in the stable being warmer, the air at the inside opening of the outtake flue will be lighter than the air outside and will rise.

The upward movement of air in the flue started in this manner is assisted to some extent by "aspiration"—that is, by the wind blowing across the top of the flue; just as a chimney has a stronger draft when the wind is blowing.

But where dependence is placed wholly on the motive power furnished by the warmer (lighter) air and by the wind blowing across the top of the outtake, the ventilating system will sometimes not operate satisfactorily in the warmer weather and under certain atmospheric conditions.

The James Improved Ventilating System is more efficient because it not only uses the same motive forces employed in other systems, but it adds the additional motive power of *suction*, applied at the outlet of the foul air flue.

It removes a greater quantity of foul air in a given time and makes the ventilation more uniformly successful under all conditions.

The James Ventilator, as before stated, offers little hindrance to the outflow of air, the air current having to make but one turn and that of large radius much less than a right angle (see "GG" "HH," Fig. 2).

The deflector in the shape of a half cone "HH" (Figs. 10 and 4) prevents outflow of air in that half of flue interfering in any way with the other half.

The little wind which can blow in, when an upward slant of wind strikes the ventilator must blow directly through and out (see D-G-G, Fig. 10).



Note improved appearance of barn by use of James Ventilators

This adds the direct pressure of the wind to the other motive forces, further accelerating the outward flow of air, instead of impeding it by causing eddies as in Fig. 8.

Thus we see that the James Revolving Hood Ventilator has for its motive forces, (1) the difference in temperature between the air in the flue and the air out of doors; (2) "aspiration"—the wind blowing across the top; (3) suction applied at the outlet; and at certain times (4) wind pressure. And, as compared with other ventilators, it has a larger outlet space for the outflowing air—unimpeded by sharp turns or obstructions.

The James Ventilator is absolutely storm proof—neither snow nor rain can enter; nor can birds get in, all openings being covered with galvanized bird proof netting as shown in Fig. 3, page 278.

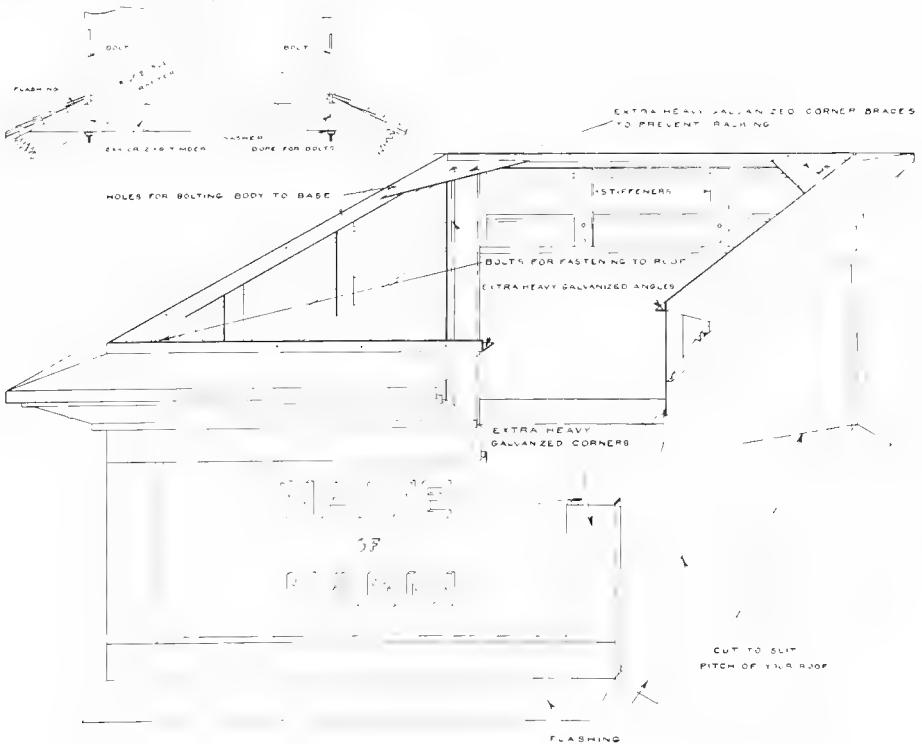
The James Ventilator lasts a lifetime; does its work without attention; interferes in no way with hay carrier track; and is easy to put in place.

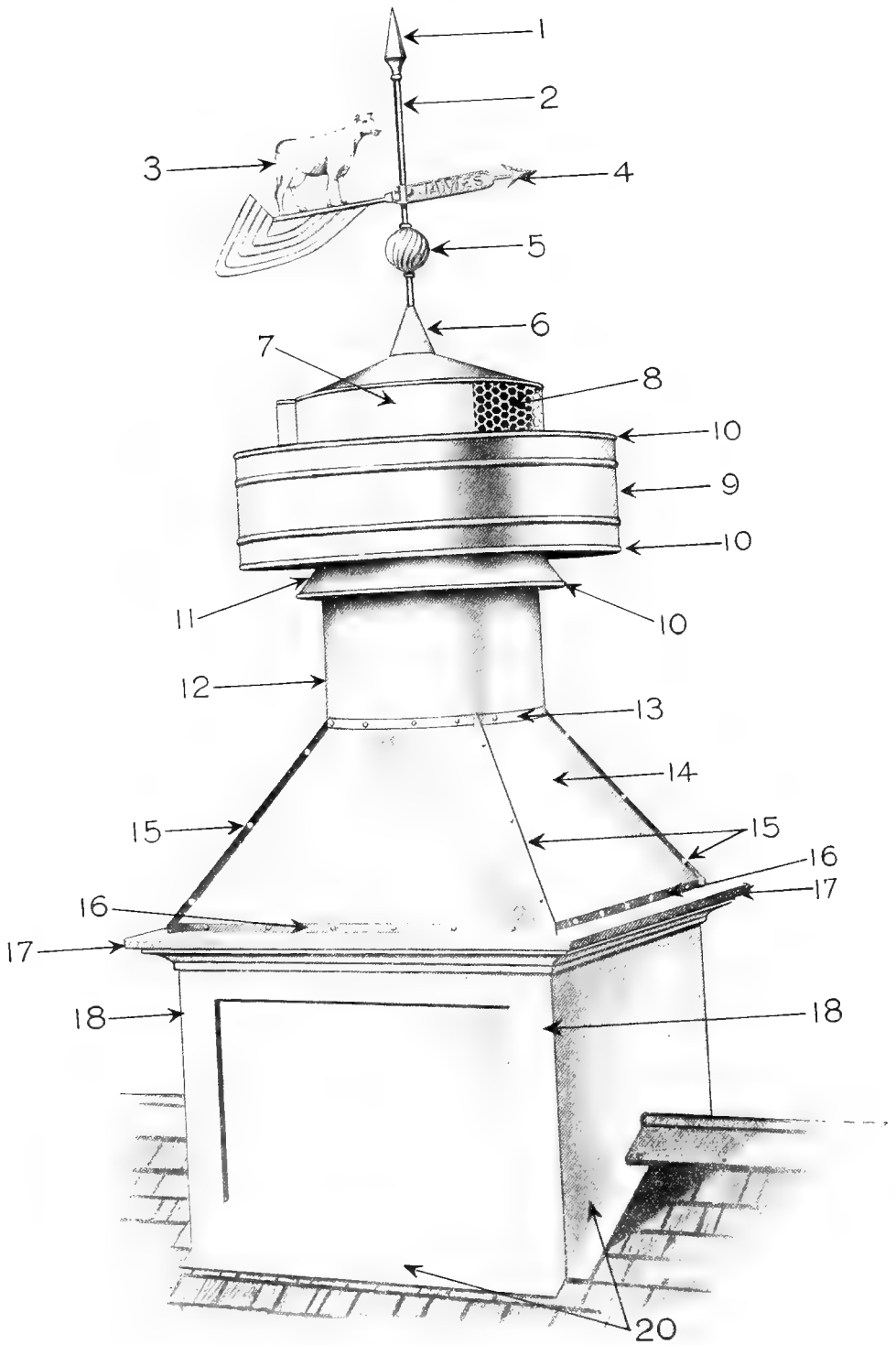
### Good Looking Barns

The James Ventilator is the finishing touch that makes the barn good looking. See page 284.

There is real value in a good-looking barn, for pleasing buildings increase the desirability of the place, give passers-by a better opinion of the owner, and assure a better price for the farm when you sell.

The ventilator is worth its cost, if only for the increase in selling value of the farm caused by the better appearance of the barn.





## Finish

All James Ventilators are coated with a high-grade aluminum paint over the heavily galvanized steel, making a beautiful satin finish.

## Sizes and Construction

Made in two sizes, Ventilator No. 1 having barrel 24 inches and Ventilator No. 2 having barrel 30 inches in diameter.

The heights are 10 ft. 8 in. in the 24-in. diameter; 12 ft. 3 in. for the 30-in.

The 24-in. ventilator has a base 50 x 50 inches over all on cornice by 27 inches high; weight of ventilator crated 260 lbs. The 30-in. ventilator has a base 60 x 60 inches by 33 inches high; weight of ventilator crated 380 lbs.

## SPECIFICATIONS

(See page 286)

1. Double cone steel top, solidly fastened on.
2. Galvanized pipe  $1\frac{1}{16}$ -inch outside diameter. This pipe passes into cone 6, to which it is securely soldered, and is also threaded into a malleable casting mounted inside of revolving hood (7).
3. Full bodied, double strength stamped zinc. Vane securely fastened to pipe and always keeps opening (8) to the wind. 4. Malleable Arrow.
5. Glass ball five inches in diameter. Extra heavy.
6. Heavy galvanized cone, adds to appearance, strengthens pipe which carries vane.
7. Revolving hood, containing intensifier and hardened steel frictionless bearing. This bearing is entirely protected from the elements and no rain, snow or ice can interfere with the motion of the hood. 8. Opening into intensifier.
9. Heavy galvanized storm bands, stiffened greatly by ornamental beading. This band with skirts inside keeps out rain and snow.
10. Heavy steel wiring, amply strengthening storm band and all skirts.
11. Skirt greatly assists in aiding the circulation of air.
12. Heavy galvanized steel body strengthened by galvanized steel angle irons which are thoroughly braced. (See Fig. 3, page 278.)
13. Special alloy non-corrosive rivets, used throughout entire structure.
14. Heavy galvanized steel body strengthened by standing seams (15).
16. The fastening at this point is the strongest possible, extra heavy galvanized angles to which the body is securely bolted by special non-rusting bolts and nuts.
17. Heavy galvanized steel cornice, made by us from our own designs.
18. Corners are made from extra heavy galvanized steel. Folded and locked into side and top sheets to form a solid and tight structure.
20. Galvanized steel flashing, so constructed as to leave the least work for the workman placing the ventilator on the roof.

Four long bolts, with nuts and washers, are furnished to bolt ventilator to the roof.

All openings are protected by galvanized bird-proof netting.

Lightning rods should be coursed around the ventilators—never through a ventilator. A bond should be made between the rod and ventilator, preferably by soldering rod to outside corners of base, making a permanent positive metal contact.





## James Ventilators with Solid Hood

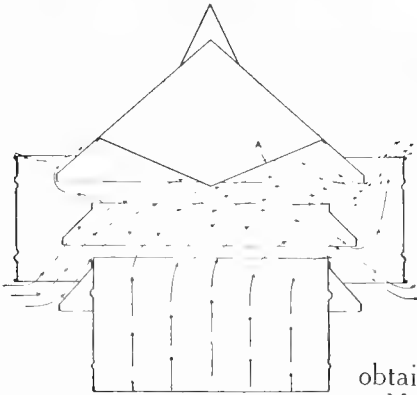


Fig. 1  
James Solid Hood Ventilator

These ventilators differ in principle from the James Ventilator with revolving hood only insofar as the inverted cone is substituted for the revolving top.

The ventilators without the revolving hood are, of course, somewhat less efficient because the larger outlet space of the revolving head and the added motive power of suction obtained through the intensifier is not used.

Nevertheless they are very efficient ventilators—more so than any other ventilator now on the market for dairy barns.

They are built on strictly scientific principles, made of the same high quality materials and of the same class of workmanship as the James Ventilators with revolving hood.

The inverted cone "A", Fig. 1, turns the air rising from the

outtake flues outward and upward.

There is no opportunity for the outflowing current of air to turn back upon itself, cause eddies, choke the flue, or interfere in any way with the free escape of foul air. The storm band and the skirts keep out snow and rain and make the ventilator proof against the wind.

All openings are protected by galvanized bird-proof netting.

Ventilators Nos. 3 and 4, as shown in Fig. 4, page 290, are furnished with weather vane.

The Ventilators with bases shown in Figs. 1, 2 and 3, will be furnished with weather vane if desired at an extra cost. Any of the six figures shown on page 292 may be selected. The cow figure will be furnished unless another style is specifically ordered. Any name or date will be stenciled on a ventilator base for \$1.00 additional.

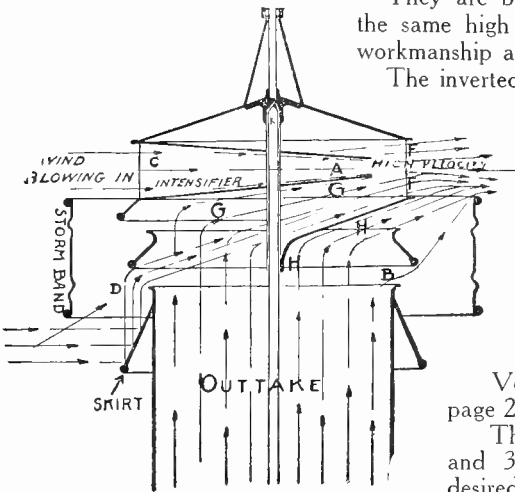


Fig. 2  
James Revolving Hood Ventilator

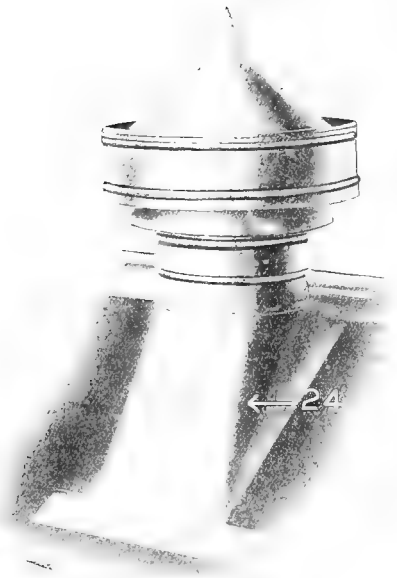
### Size of James Ventilator to Buy

Size	WITHOUT REVOLVING HOOD			WITH REVOLVING HOOD		
	Cows	Horses	Hogs	Cows	Horses	Hogs
12"	4	3	10			
18"	9	7	24			
24"	15	12	42	17	13	48
30"	23	18	64	26	20	72

### Length of Building

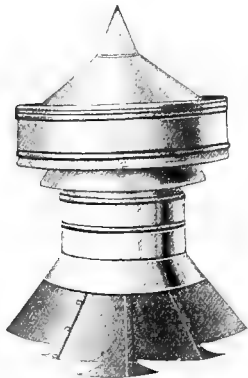
(Building not over 36 ft. wide)

1 to 35 feet.....	One 24 inch	101 to 125 feet.....	Three 24 inch
36 to 50 feet.....	One 30 inch or two 24 inch	126 to 150 feet.....	Three 30 inch or four 24 inch
51 to 75 feet.....	Two 24 inch	151 to 175 feet.....	Four 24 inch
76 to 100 feet.....	Two 30 inch or three 24 inch	176 to 200 feet.....	Four 30 inch

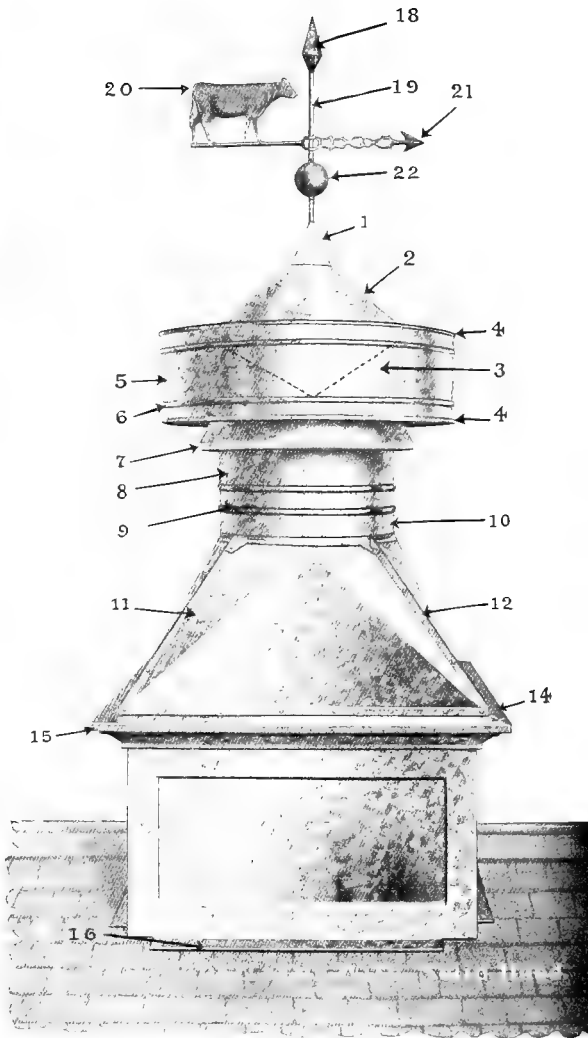


**Fig. 1**  
 Sizes 12 and 18 inch

Weight crated  
 Ventilator No. 5, 12 in.—36 lbs.  
 Ventilator No. 6, 18 in.—70 lbs.



**Fig. 3**  
 Ventilator No. 7  
 Size 12 inch  
 Weight crated  
 36 lbs.



**Fig. 4**  
 Sizes 24 and 30 inch  
 Weight crated  
 Ventilator No. 3, 24 in. — 206 lbs.  
 Ventilator No. 4, 30 in.— 320 lbs.

# James Ventilators with Solid Hoods

## SPECIFICATIONS

Applying to Figures 1, 2, 3 and 4, pages 290 and 292.

1. Heavy galvanized finial. 2. Heavy galvanized cone.
3. Inverted inner cone. Turns air currents out and up. See Fig. 1, page 289.
4. Heavy steel wiring amply strengthening storm band, on sizes above 18-in. diameter.  
On sizes 18 in. or less, edge of storm band is folded and compressed.
5. Heavy galvanized storm band, with skirts inside to keep out rain and snow.
6. Heavy beading stiffening and strengthening storm band.
7. Skirt greatly assists in aiding the draft.
8. Heavy galvanized upper round body.
9. Special bolts and nuts for fastening upper round body to lower round body. (Round body can be lengthened by inserting desired length of tube at this joint.)
10. Heavy galvanized lower round body.
11. Special alloy non-corrosive rivets used throughout the entire structure.
12. Standing seams used to strengthen body.

### Applying to Figures 1, 2 and 3 only

13. Galvanized flashing, so constructed as to leave the least work for the workman when placing the ventilator on the roof.
23. Heavy galvanized combination lower body and base used in mounting ventilator on flat roofs or on ridge of pitched roofs.
24. Heavy galvanized combination lower body and base used in mounting ventilator on side of roof.
25. Heavy galvanized lower body and base used in mounting ventilators on round barns and silos.

### Applying to Figure 4 only

14. Heavy galvanized steel cornice, made by us from our own designs.
15. Corners made from extra galvanized steel. Folded and locked into side and top sheets to form a solid and tight structure.
16. Galvanized steel flashing so constructed as to leave the least work for the workman in placing the ventilator on the roof.
18. Double cone steel top, solidly fastened on.
19. Galvanized pipe  $1\frac{1}{16}$ -in. outside diameter. This pipe passes into cone 2, to which it is securely soldered, and is also threaded into a malleable casting mounted inside of cone.
20. Full bodied, double strength stamped zinc.
21. Malleable arrow.
22. Glass ball, five inches in diameter. Extra heavy.  
Four long bolts with nuts and washers are furnished to bolt ventilator to roof.

### Finish

All James Ventilators are coated with a high-grade aluminum paint over the heavily galvanized steel, making a beautiful satin finish.

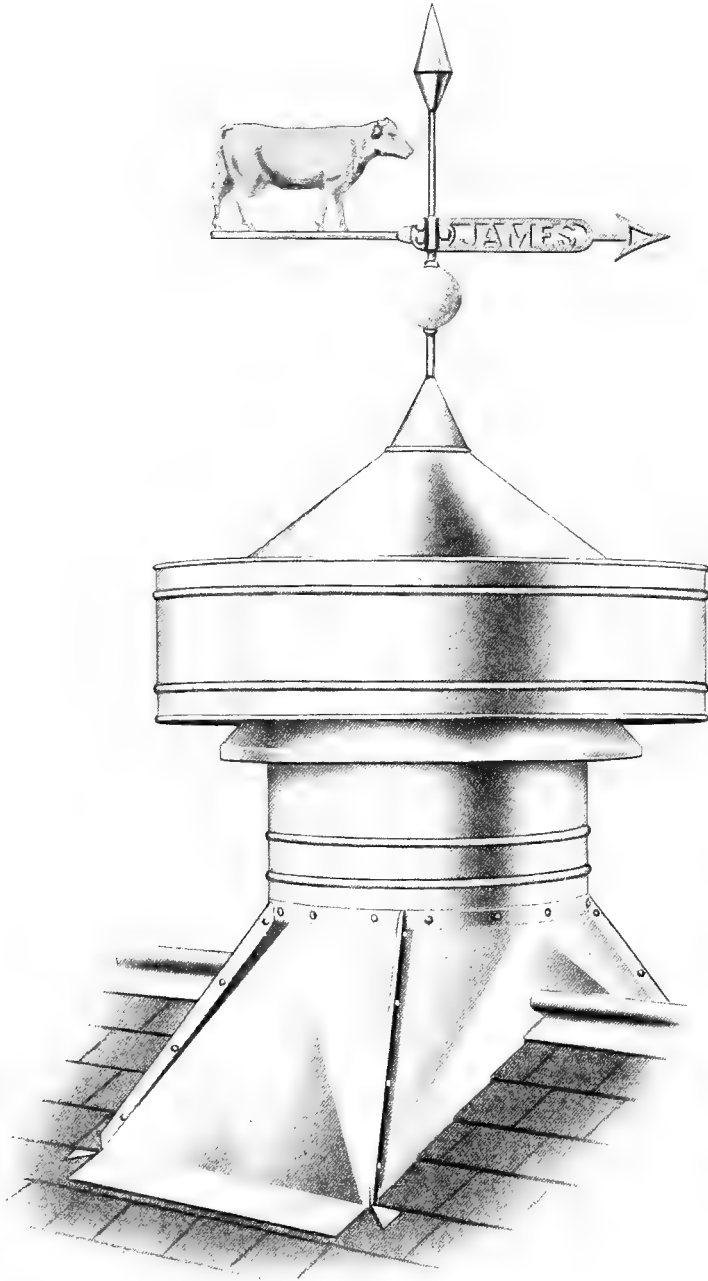
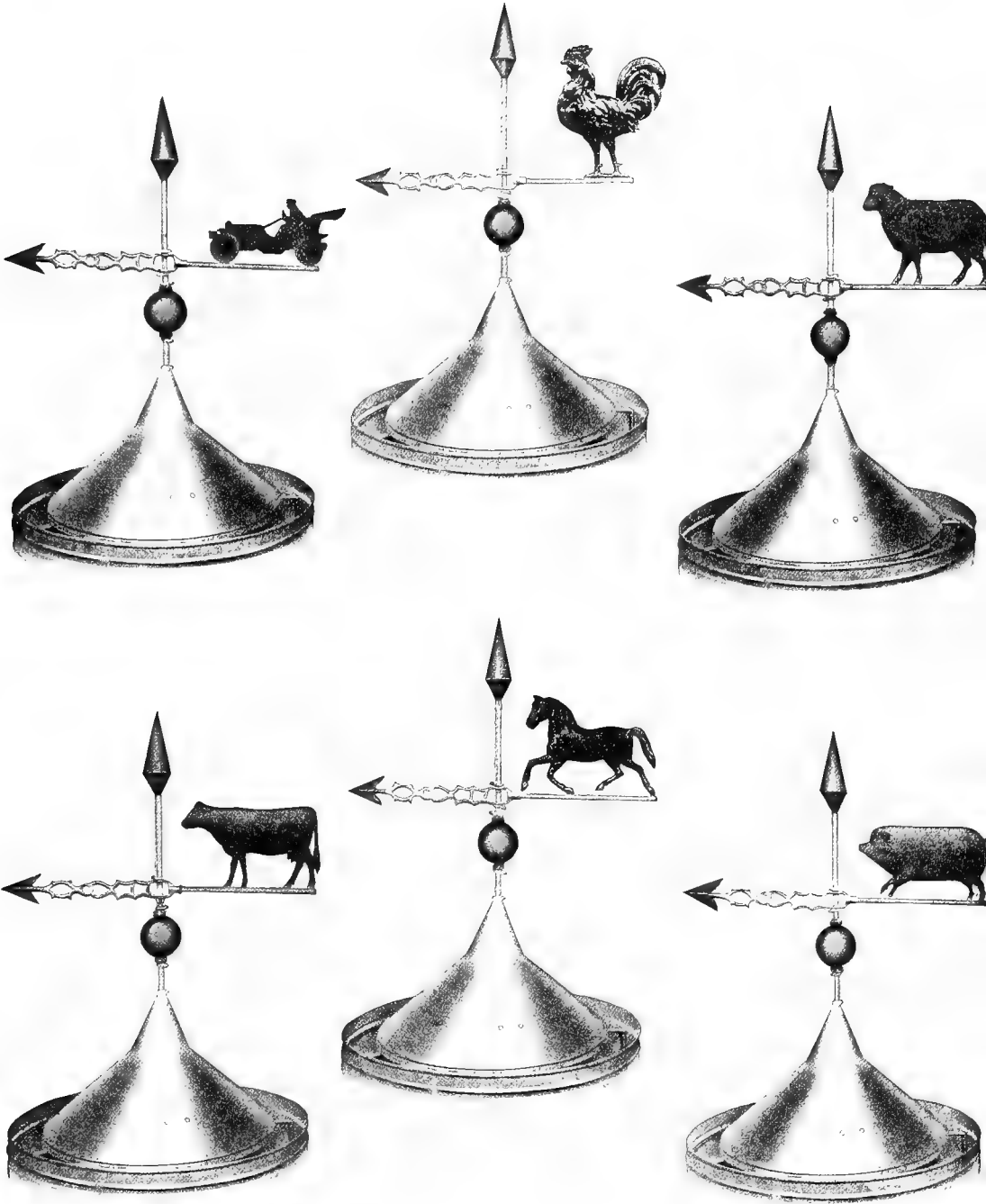


Fig. 2

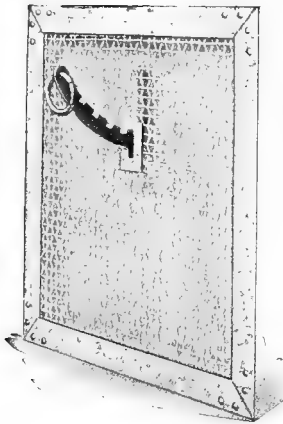
	Weight Crated
Ventilator No. 8, 12 in. barrel	36 lbs.
Ventilator No. 9, 18 in. barrel	70 lbs.
Ventilator No. 10, 24 in. barrel	116 lbs.
Ventilator No. 11, 30 in. barrel	185 lbs.



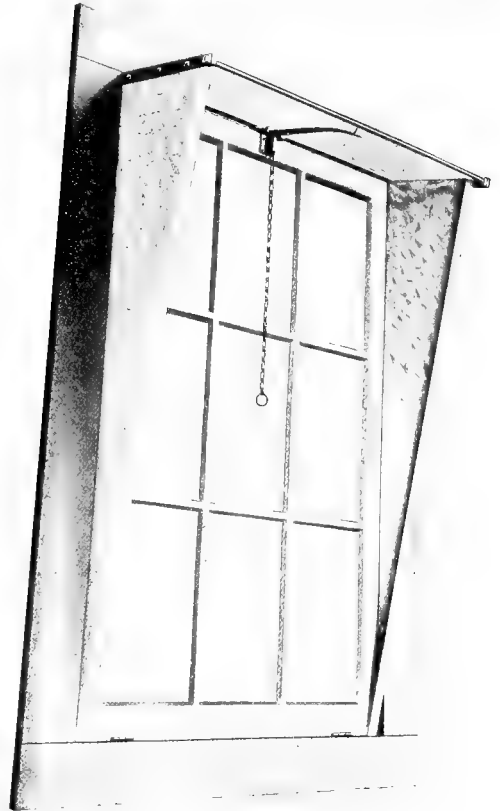
Figures for James Ventilator Vanes



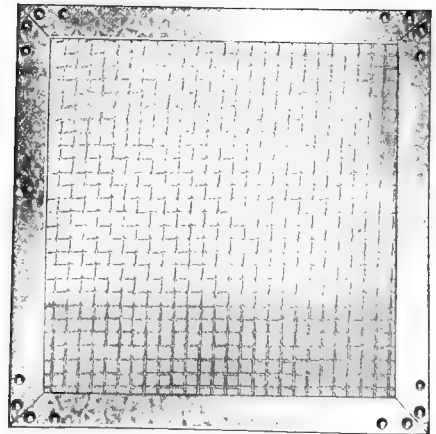
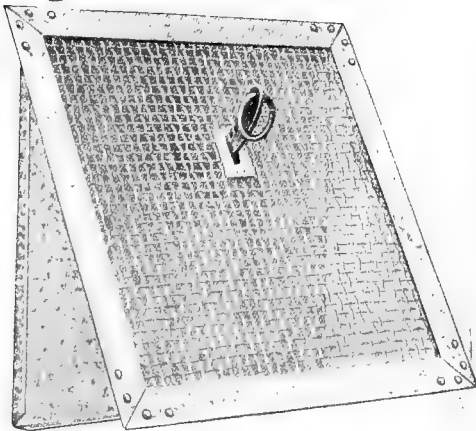
Adjuster for  
Outtake  
Length 18 inches



James Registers



Window Ventilator Closed



## Double Glazed Windows

The double glazed window is essential in the dairy barn, because the dead air space between the double glass prevents undue radiation of heat, and eliminates condensation of moisture on the windows.

The window illustrated on page 294 is the James standard barn sash, 9 lights, each 8 in. x 14 in., 1 $\frac{3}{4}$ -in. glazed double glass. Glass is of single strength.

The Sash is 29 in. x 14 in. over all.

## James Window Ventilators

For use where the fresh air enters the barn through the windows. James Window Ventilators when the windows are tilted in, throw the fresh air up against the ceiling, diffusing it and prevent the air entering the stable at the sides of the open windows.

Furnished with a device that permits locking of the window in any of five positions; this holds the window solid and prevents the wind from knocking it back and forth.

## James Registers

(For Intakes Only)

The James registers are designed specifically for barn ventilation purposes. Registers made of cast iron have two serious objections: the metal takes up too much room in the opening, cutting down the effective area; in the second place the cast iron registers are too quickly affected by the moisture usually found in the dairy stable.

The wire mesh of the James register gives far greater effective opening and the register being galvanized throughout is not affected by moisture. In twenty-four hours, twenty cows will throw off moisture equal to almost one barrel of water; this shows how important it is that the registers be galvanized.

The complete register has a "tell-tale" device to fasten register open in several positions; a glance down the row of tell-tales shows which registers are open and how much.

Register faces (designed for outside intakes only) are regularly furnished 8 in. x 8 in., 10 in. x 10 in., 6 in. x 14 in., 8 in. x 14 in., 10 in. x 14 in., 14 in. x 14 in.

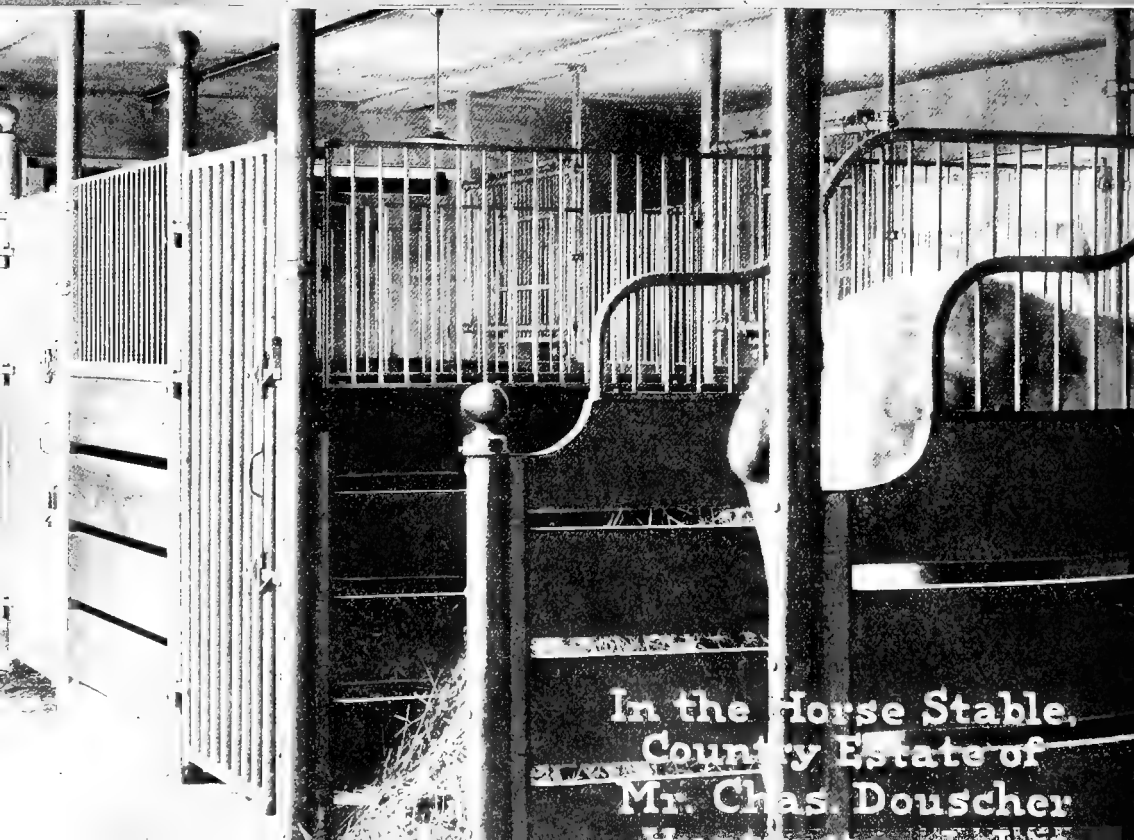
The complete registers are furnished: 8 in. x 8 in., 10 in. x 10 in., 14 in. x 14 in.

The 14 in. x 14 in. complete register is recommended for use where the intake flues open into the stable—that is, in the ceiling or side wall near the ceiling. This size being larger than the intake flues, reduces the high velocity of the incoming air, drafts are lessened and better diffusion of the fresh air secured.

The 8 in. x 8 in. and 10 in. x 10 in. registers are intended for concrete, brick and hollow tile wall and under conditions where there are but a few head of stock.

## Adjuster

Adjuster for opening an outtake flue. (See illustration, page 294.)



In the Horse Stable,  
Country Estate of  
Mr. Chas. Douscher



# James Horse Stable Equipment

The United States Department of Agriculture estimates that between fifteen and twenty dollars per year per horse is wasted in feed, which might be prevented by the use of modern and convenient methods and up-to-date equipment in the stables. If it were possible to save but \$10 to \$15 per animal, this would be enough to practically pay for complete sanitary equipment.

It is estimated that 25 per cent of the annual colt crop is lost, most of which might be prevented by intelligent treatment of the mare and the newborn colt. To give this proper attention, a box stall is an absolute necessity on every farm where colts are raised.

Proper care and treatment of the horses will quickly repay the owner through their greater capacity for work, and the added years of service.

If a cow is not properly taken care of, the loss to the owner is quickly shown by the decrease in milk yield.

The importance of providing cleanliness, comfort, pure air and light for the horse is not always realized.

A horse is out in all kinds of weather from early morning until late at night, kept at all kinds of work, in the paved street or in the field. To maintain its strength and vitality and render the greatest service to its owner, the horse should have a comfortable stall in which to sleep; a stall that is reached by the sunlight during the day, that it may be properly disinfected; a stall that permits pure, fresh air to reach the animal; and feeding racks and mangers that may be easily and regularly cleaned.

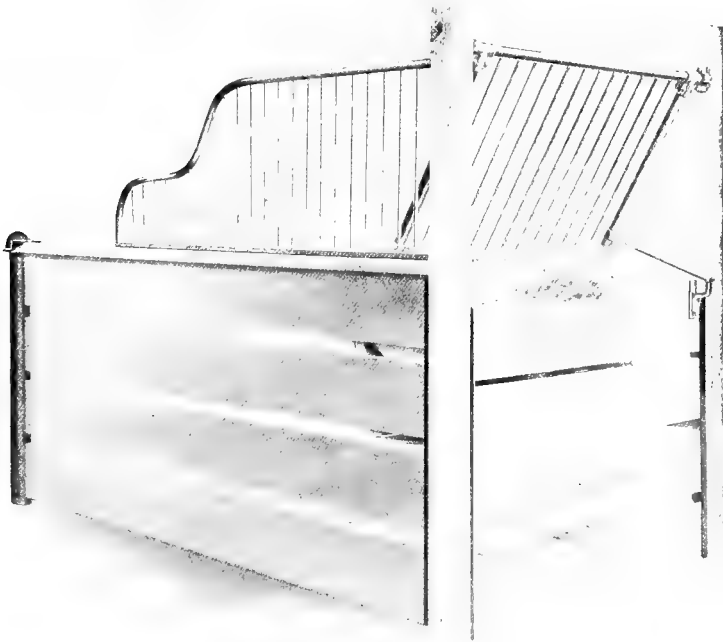
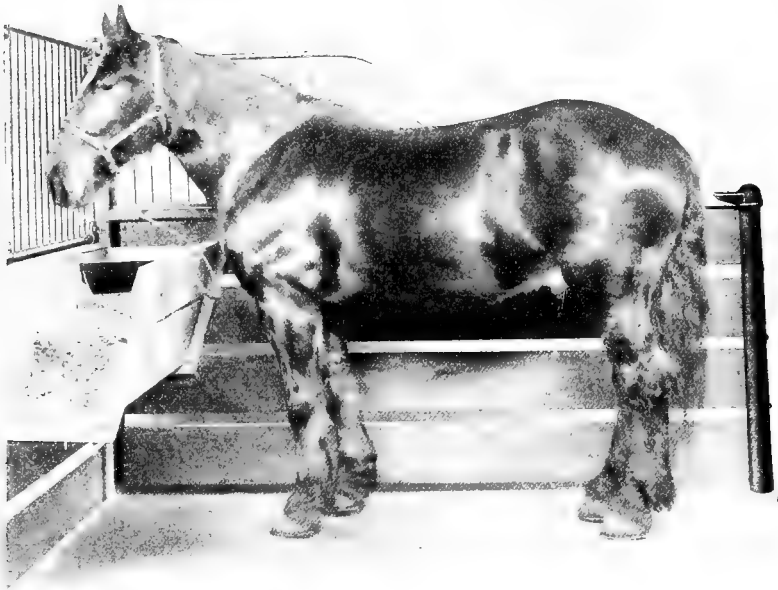
Cheerfulness counts for much in keeping horses in good condition. This is especially true in the winter, when they must stay in the stable many days. They appreciate sunlit quarters. They respond as readily to kind treatment as to proper feeding. When such high prices for good horses prevail, they are surely worth looking after.

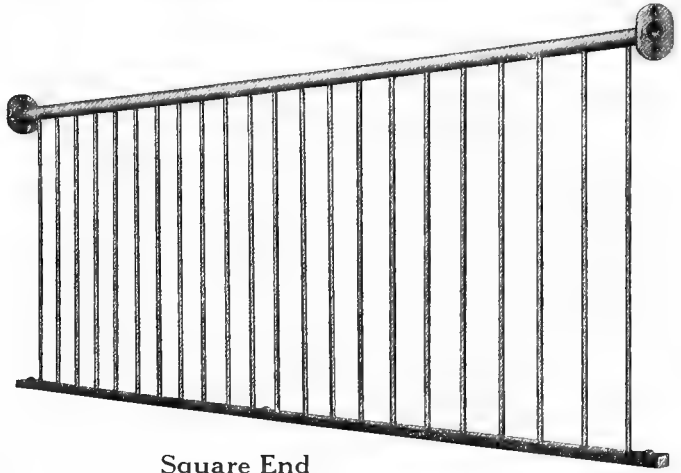
Steel fittings for the horse stable are indispensable to any farmer who prides himself on his animals and is anxious to have them look their very best.

The open construction of the steel guards allows the sunshine to flood through the building. Every horse in the row of stalls can be seen and every one shown off to the best advantage.

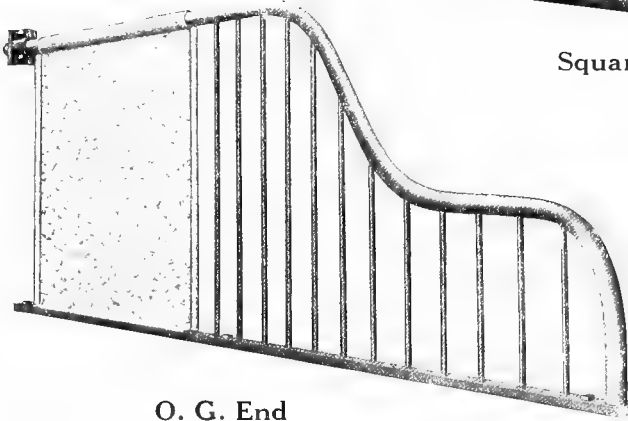
James horse stable fixtures can be installed simply, easily and quickly.

REG. U.S. PAT. OFF. TRADE MARK. MADE IN U.S.A. PAT. 1,111,111. JAMES WAY & SONS, INC., CHICAGO, ILL. U.S.A.





Square End



O. G. End

(When guard shown above is used in front of single horse stalls (page 296) or in horse box stalls (page 302), it may be had with Grain Feeding Opening at slight additional cost. This opening is provided with a device that permits raising three of the spindles).

## James Horse Stall Guards

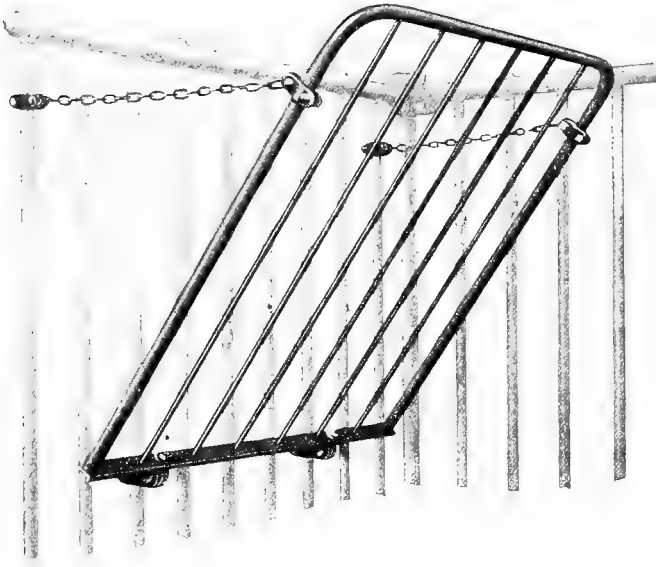
Light and sanitary, allows better ventilation, lets the sunlight strike the stall and does not collect the dirt; more permanent than wood. Steel upright bars are much better than wire mesh, for the wire does not have the strength and will rust out in a short time. Harness hames will not catch in these bars and tear them out as they do with the wire stall guards.

Uprights of  $\frac{1}{2}$ -in. round steel spaced 3 inches apart fitted into  $1\frac{5}{8}$ -in. O. D. top horizontal and securely riveted through a  $1\frac{1}{2}$  in. x  $\frac{3}{4}$  in. channel below. Furnished either square or O. G. end. Standard lengths 6 feet but made any length special. Height of guard 26 inches. Fitting on upper horizontal provides adjustment if post to which it is attached is not exactly vertical.

Either style guards also furnished with 20-gauge galvanized sheet solid end, as illustrated above.

## Swinging Panel Front

Horizontals and vertical frame of  $1\frac{5}{8}$ -in. O. D. pipe. Spindles of  $\frac{1}{2}$ -in. round steel rod. Fittings for clamping frame of best annealed malleable. Panel pivoted at the top and furnished with swinging mechanism and stop. (See page 298.)



## James Rod Front Hay Rack

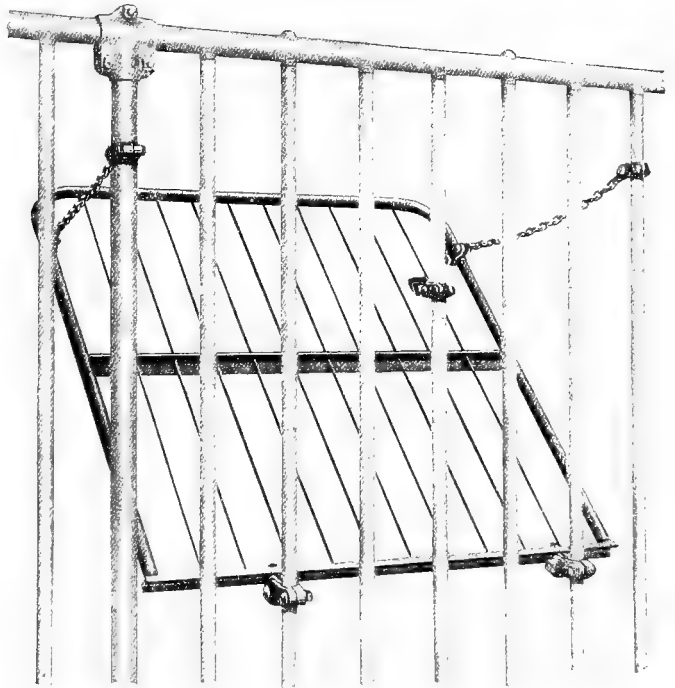
For use on solid wall or partition or inside of horse box stall or steel pen.

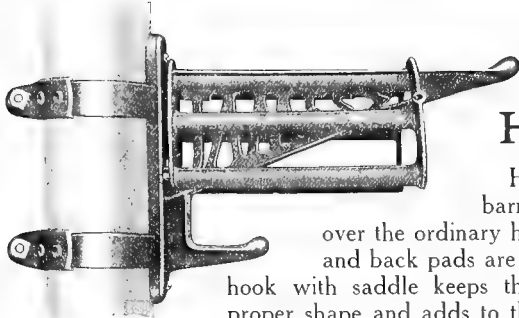
Rods are  $\frac{1}{2}$ -in. round steel spaced about 5 inches on centers fitted in a  $1\frac{1}{8}$ -in. O.D. pipe on top and riveted through a  $1\frac{1}{4}$ -in. x  $\frac{1}{2}$ -in. channel below. Size 36 inches x 36 inches. Finished in grey enamel.

## James Rod Back Hay Rack

For use on outside of horse box stall and on the outside of steel pens.

Rods are  $\frac{5}{16}$ -in. round steel extending through a 1-in. x 1-in. angle cross bar, fitted in a  $1\frac{1}{8}$ -in. O. D. pipe on top and securely riveted below on to  $1\frac{1}{4}$ -in. x  $\frac{1}{2}$ -in. channel. Size 36 inches x 36 inches and furnished in a baked enamel finish to match pens.





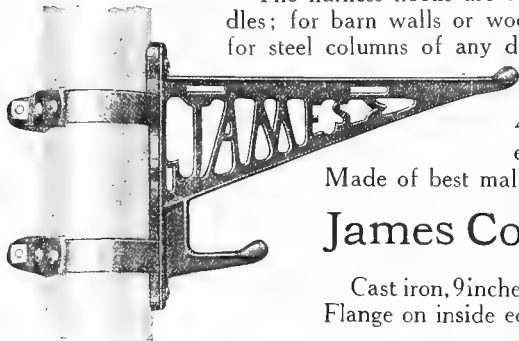
## James Harness Hooks

How often one goes into a barn where the harness is hung over the ordinary hook and finds that the collars and back pads are broken! The James harness hook with saddle keeps the collars and back pads in proper shape and adds to the life of the harness.

The harness hooks are furnished with or without saddles; for barn walls or wood columns; and with fittings for steel columns of any diameter.

Harness hooks are carried in stock for columns 3½ in., 4 in., 4½ in., and 5 in., in diameter; other sizes made to order.

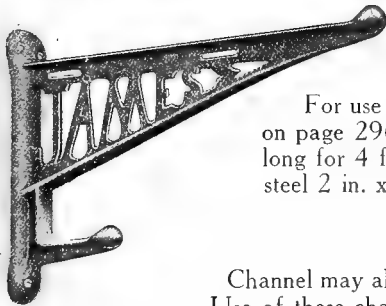
Made of best malleable. Size: 11¾ in. long.



## James Corner Feed Box

(See page 296)

Cast iron, 9 inches deep by 17 inches by 17 inches. Flange on inside edge, to prevent waste of feed.



## James Horse Stall Post

For use at rear of wooden partitions as shown on page 296. 3½-in. O. D. boiler tube, 5 ft. long for 4 ft. partition. Furnished with channel steel 2 in. x 1½ in., 12 gauge.

## Channel

Channel may also be had for front of stall partitions. Use of these channels makes it possible to easily and quickly remove the planks from the partitions, should that at any time be desirable.

For horse stalls with concrete partitions, channel will be furnished 4 ft. long by 4 in. by 1½ in., number 12 gauge at additional cost.



The 2" Channel is excellent as a "cribber" when used on edge of wood manger front, preventing horses from gnawing wood.





James Horse Box Stall

## James Concrete Horse Box Stall

(See Page 302)

### SPECIFICATIONS

**CORNER AND INTERMEDIATE POSTS:** 1 $\frac{5}{8}$ -in. O. D. pipe extending into floor.

**GATE POSTS:** 1 $\frac{7}{8}$ -in. O. D. double strength pipe reinforced at the top of partition wall by a 1 $\frac{3}{8}$ -in. O. D. pipe embedded in cement.

**PANELS:** These consist of the square end horse stall guards (page 299); the uprights being of  $\frac{1}{2}$ -in. round steel spaced 3 inches apart, fitted into 1 $\frac{5}{8}$ -in. O. D. top horizontal and securely riveted through a 1 $\frac{1}{2}$ -in. by  $\frac{3}{4}$ -in. channel below. Height of panel 26 in. Standard length 6 feet but made any length special.

**FITTINGS:** Best annealed malleable  $\frac{7}{16}$ -in. cut thread bolts used with fittings.

**ORNAMENTS:** Best malleable; dust-proof type.

**GATE:** Frame and center horizontals of 1 $\frac{7}{8}$ -in. O. D. pipe with 1 $\frac{1}{16}$ -in. O. D. pipe upright spaced approximately 2 $\frac{1}{2}$  inches on lower half of gate. All fittings of best malleable. Equipped with safety lock and supported by 3 offset hinges of the best malleable.

**GATE LOCK:** Double latch, connected by  $\frac{3}{8}$ -in. square steel rod. Gate locks when slammed shut, can be opened only by hand, it being necessary to raise the lever and turn.

**FINISH:** The steel is first mechanically cleaned, removing scale, grease and foreign matter, then followed with chemical bath, thoroughly preparing the material for painting; it is then finished with the best grey protective enamel, baked for two hours at a high temperature. (See page 129.)

**HEIGHT:** With 6-in. curb under gate stall is 6 feet 5 inches from the floor. Shipped assembled in panels.

## James Wood Horse Box Stall

### SPECIFICATIONS

For a horse box stall of planks instead of concrete, specifications are same as above excepting that all posts have fittings and channels attached necessary to take planks 1 $\frac{3}{4}$  in. thick.



Detail of James  
Steel Column  
Red-Granite  
Filled

Waukesha County Asylum Barn  
Waukesha, Wis.



## The James Composition Columns

Every man these days wants steel stalls and would not think of putting in wood stalls in a new barn. The steel column has every advantage over wood columns that the steel stalls have over the wood stalls.

In the two-story barn of the usual width, the second floor must be supported either by trussing from above or by columns below. Ofttimes too, columns are needed in one-story barns to support the ceilings. There is absolutely no objection to columns in the stable providing they are of the right kind and properly located.

The James Composition Columns overcome all the objections to the old-style wood columns. They have strength with neatness—the wood columns to have equal strength must be three times the size.

Light in the dairy barn is of the greatest importance—for light kills disease germs; it is the best disinfectant. The heavy wood supporting columns tend to keep the light out; James columns, because of the smaller size, let the daylight in.

Wood columns collect dust—cracks and rough surfaces offering refuge to countless germs. The surface of James columns is a smooth enamel—no place for dust and germs.

The appearance of the James columns harmonizes with modern steel stalls and pens; the cost of the columns is justified for appearance's sake alone.

The saving in space by the use of the James columns is very considerable. Where a heavy wood support may reduce the width of one or two stalls, the James columns so fit in with the stalls or pen that no room is lost, nor any discomfort caused the animals. The 4½-inch James column, for example, has a safe carrying capacity equivalent to an oak or a yellow pine post 6 in. x 8 in., or a white pine post 8 in. square.

The 4½-in. James column has a cross section of 15.9 inches as compared with 48 square inches cross section of the oak or yellow pine post and 64 square inches of the white pine post.

From this it will be seen that the James column of equal strength takes less than one-third the space occupied by the wood column. At the same time, the James column has less than half the surface of a wooden column of equal strength, which is an item worth consideration when it comes to painting or cleaning.

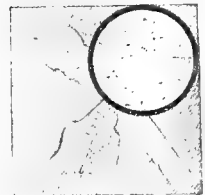
It is no longer necessary to use wood columns at the rear of horse stall partitions. James columns fitted with iron channels may be used to hold the partitions. The use of James Columns with horse stalls gives the stable a uniform appearance.

Wood columns set on cement floor ofttimes rot out in three or four years. The frequent replacement of wood columns under these conditions makes the James columns cost far less in the long run.

James columns are less expensive than the trussing required if columns are not used—at the same time the haymow is clear of obstruction. They cost less than cast iron, are stronger, and less liable to break in handling.

When arranging your floor plan, it is important that the supporting columns be correctly spaced. Otherwise, the location of the columns, whether of wood or of steel, may interfere seriously when you come to put in stalls and pens. If you will write us, we will tell you how best to locate the supporting columns in your barn. State inside dimensions of the stable and number of animals to be provided for.

James Composition Columns are made up of new cold-drawn, seamless, high-pressure boiler tube, straight and clean as a new gun barrel. They are filled with a secret



Comparison of space occupied by 6 x 6 white pine post and a James column of same weight carrying capacity.

formula, the main ingredients of which are red granite, torpedo washed sand and Portland cement.

Beware of columns not properly filled. Concrete shrinks in hardening and tends to leave a slight space next to the steel shell, weakening the strength of the column. The James process of filling the columns offsets this shrinking tendency, as well as avoiding air pockets and sponginess which would give rust a chance to attack the column from the inside.

Prices on James Columns should not be compared with columns made from inferior materials; or from second-hand boiler tubes, because of the danger of such tubes having rusted thin in spots.

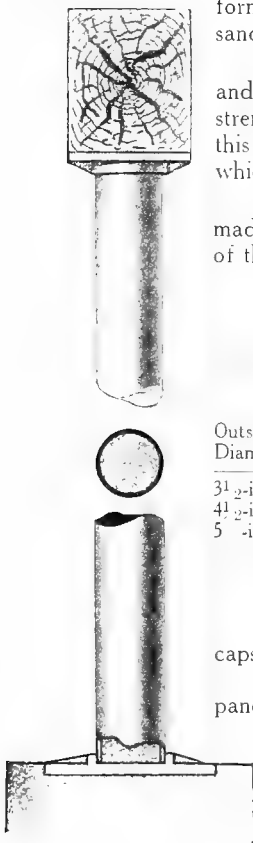
### Table of James Columns, their Capacities and Equivalents in Wood Columns

Outside Diameter	Safe carrying capacity in tons of James Steel Columns					EQUIVALENT TO		
	6 Ft. Length Tons	7 Ft. Length Tons	8 Ft. Length Tons	8½ Ft. Length Tons	9 Ft. Length Tons	White Pine	Yellow Pine	Oak
3½-in.	9	8½	8¼	8	7½	6x 6 in.	5x5 in.	5x5 in.
4½-in.	14	13½	13	12¾	12½	8x 8 in.	6x8 in.	6x8 in.
5 -in.	20½	20	19½	19¼	19	8x10 in.	8x8 in.	8x8 in.

### For Hog Houses

We will furnish 2¾-in. and 3½-in. O. D. unfilled columns with caps and bases, for one-story hog houses.

Standard fittings are supplied for connecting James steel hog-pen panels to these columns.



## The James Adjustable Milk Stool

Here is the milk stool that every farmer wants, adjustable as to height.

It is just the right size and weight, neat and handy, with comfortable wood seat for warmth in cold winter weather. It is sanitary and easily kept clean.

It is a handy little seat to have around for other purposes too—as an extra seat in buggy, wagon or automobile, and for use about the house and barn and tasks that permit sitting down.

If the stool is not perfectly satisfactory, you may return it and your money will be refunded.



## SPECIFICATIONS

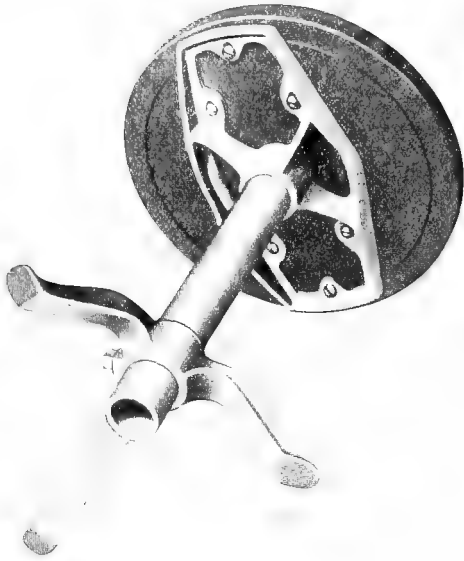
**FRAME:** Legs of malleable iron with screw for adjusting. Posts of  $1\frac{1}{4}$ -in. O. D. pipe, securely fitted to the malleable seat support.

**SEAT:** Of seasoned birch, attached with six round head screws. Slots in the malleable seat support permit the wood seat to contract or expand without cracking, in case of excessive moisture or dryness.

The wood top is stained mahogany color, covered with oil glaze. Frame is painted battle ship gray.

**SIZE:** Adjustable from 12 to 14 inches in height. Can be made lower by sawing off the pipe. Diameter of seat 9 in. Weight approximately 6 lbs.

May be shipped by parcel post, express or freight, as preferred.



## James Hog Trough

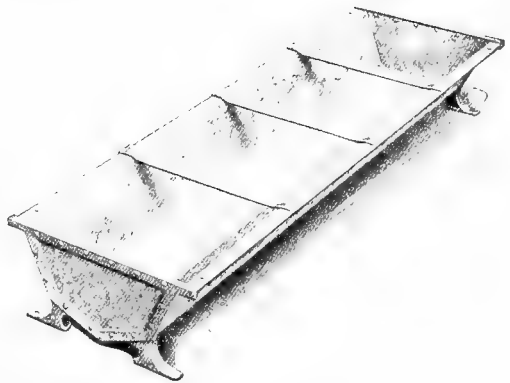
PATENT APPLIED FOR

Clean water and sanitary feed are necessary for the good health of hogs. The James Hog Trough is easy to clean and easy to keep clean. It is so designed that the hogs may get all the liquid. If any liquid should be left in the trough in cold weather, no damage will be done to the trough because of its V-shaped bottom and flaring sides, for the expansion of the forming ice will be upward and not against the sides.

The trough is built of 18-gauge galvanized sheet steel, ends are lock seamed, with reinforcing plates on the corners; angle iron dividers across the trough at intervals of 12 in., riveted to the galvanized sheets. These angle iron dividers are so strong that a man can stand on them without bending them: they not only give the trough great rigidity and strength so that it cannot wrack, but they also separate the hogs, keeping any one hog from monopolizing the entire trough. Hogs can't tip the trough.

The legs and end frame of the trough are of best malleable, fastened to the trough with heavy rivets.

The James Trough is the most economical trough to buy, as it costs but little more than a wooden trough and will outlast many built of wood.





## James Barn Scrapers

At last, you can obtain a floor scraper that will actually clean the floors.

The home-made scrapers and those which have been placed on the market heretofore chatter, jump and slide over the manure. They don't hug the floor.

The design and shape of the James Scraper is such that it gets right down under the manure and clings to the floor. No matter whether you push down hard or shove it gently, it sticks to the floor. The harder you push, the deeper it digs. It is correct in principle.

For cleaning the walks and floors back of the cows and concrete barn yard, the James Scraper is unexcelled. Its great width of straight edge makes quick work of this job. It does work that cannot be done satisfactorily with a shovel, taking off all the dirt and leaving the cement floor clean so that cows are not liable to slip as they come in or leave the barn.

The 15-inch width scraper is designed for use in the gutters, which usually are built 16 inches wide.

The James scraper is also unexcelled for removing packed snow or ice from cement walks, and for the cleaning of city pavements.





from binding. Castings of best malleable, heavy design; large bolts used to fasten the handle to the form. Handles are of second-growth ash thoroughly seasoned, tough, strong and smooth.

Manger cleaners are made in two styles regularly, one to fit the trough of the James complete manger, the other to fit the trough where James manger divisions are used; specify which is wanted when ordering.

Manger cleaners will be made to fit any form at a slight additional cost.

The floor scraper blades are made of high carbon shovel steel and will wear a long time; castings of best malleable riveted to blades by powerful pressure and bolted to handle; handles of second-growth ash thoroughly seasoned, tough, strong and smooth. All metal parts given a coat of black paint.

Made in 24-in. and 15-in. widths.

## James Manger Cleaner

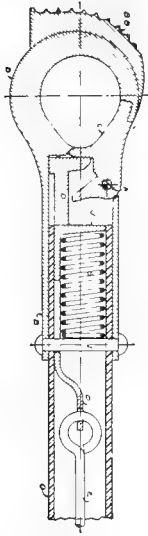
The manger cleaner is so shaped as to fit the manger trough, and the trough can be cleaned of refuse about as fast as a man can walk. The handle is set at an angle so that it is not necessary to reach under the mangers.

The form is made of thoroughly seasoned birch, equipped with a steel roller on the end that works against the curb, which makes it easy to operate, and prevents cleaner

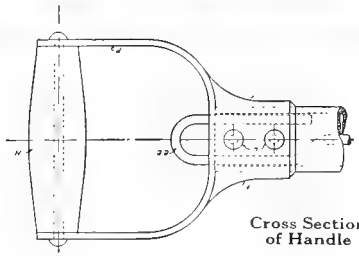
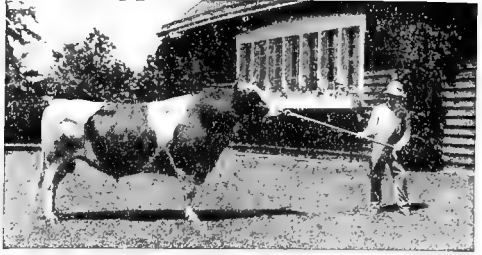




The Lock Hook



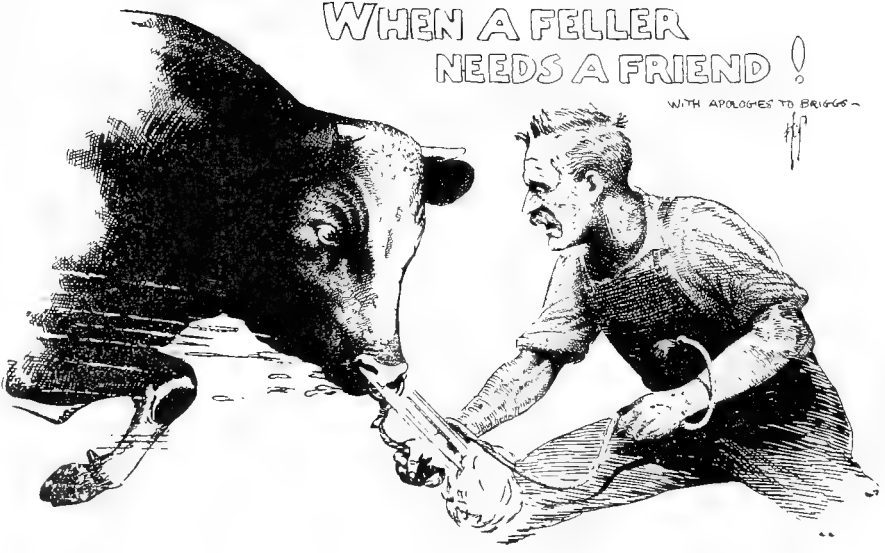
Cross Section of Lock Hook



Cross Section of Handle

WHEN A FELLER  
NEEDS A FRIEND !

WITH APOLOGES TO BRIDGE ~



## “Safety First”

How often the newspapers tell the tale of some farmer's untimely death or terrible crippling under the hoofs and horns of a supposedly gentle bull—for almost invariably it is the “gentle” bull that maims and kills.

One handles with care the bull that is known to be vicious; but the gentle bull gradually gains one's confidence and trust until some day the killing instinct suddenly comes.

In most of the newspaper accounts merely a bare recital of the facts of the occurrence is given.

But to the man of imagination, familiar with the nature of bulls, even these bare, skeletoned news reports are filled with tragedy.

He sees not only the untimely carrying away of a man from his sphere of usefulness, but he sees the deeper tragedy—the wife, suddenly bereft of her husband, the little children deprived of a father and protector, the farm left without a guiding and directing head.

He sees the stunning, sudden blow, the bitter anguish, the empty days that follow.

And he wonders why men will continue to risk not only their own lives, but the welfare of the wives and children to the mercies of a powerful brute that knows no law other than that of might.

He wonders why men will persist in trusting a bull in the face of the terrible accidents that happen daily.

He wonders how often men must be told that no bull is trustworthy, that it's bull-nature to attack suddenly, without warning, viciously, without provocation.

Don't trust the bull! Don't trust any means of handling him except one in which you are sure of having and keeping the upper hand.

Remember the experiences of scores of maimed, crushed men the past year! It is better to be safe than sorry.

## James “Safety First” Bull Staff

PATENTED

The main purpose of a bull staff is to protect the life and safety of the man handling the bull. A good staff is insurance against terrible accidents and even death.

The staff must be built to stand up under tremendous strain when the real test comes. The James “Safety First” staff is designed not only to protect the man handling the bull, but that, like a curb bit on a horse, the animal may be more easily controlled.

The lock hook has roughened edges; a pressure of the staff against the bull's nose or a slight turning of the staff gives control of the animal whether walking in front of him or at the side. The pinch of the rough edge promptly brings him to time.

The hook is automatically kept locked by a strong spring inside the handle of the staff. The hook can be unlocked only by pulling on the ring in the handle; release the ring and the lock snaps shut.

A pull on the ring unlocks the hook, so that it can be easily inserted in the ring in the bull's nose, reaching in through the stanchion or through the gate paneling if that be necessary. There is no chance of the bull unlocking the hook.

The staff is 5 feet in length, weighs  $6\frac{1}{4}$  pounds. Made of  $1\frac{5}{8}$  in. O. D. steel tubing, thickness of pipe wall about  $\frac{1}{13}$  in., with malleable lock hook and malleable handle, riveted on with  $\frac{3}{16}$  x  $\frac{1}{4}$  in. rivets. There is no wood used in this staff.

Finished in two styles: No. 2, the staff, lock hook and handle are sherardized; No. 2-N. P., the lock hook and handle are nickel-plated with the staff finished in battleship grey enamel, baked on.

The No. 2 is the more satisfactory for everyday use, but for show purposes where an especially handsome finish is desired, the No. 2-N. P., is often preferred.



At slight additional cost, we will furnish this name plate printed as shown in illustration "B." If preferred, we furnish a name plate of blank cardboard with two pieces of transparent celluloid instead of the black plate.

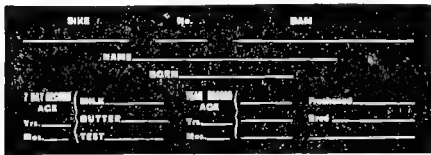
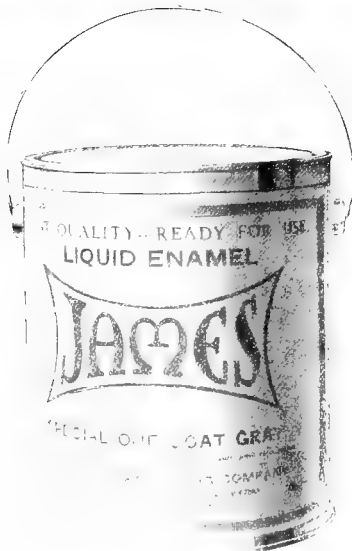


Illustration "B"



## James Paint

Barn equipment should be given some care, the same as other machinery, if it is to be kept in perfect working order and give maximum service.

Equipment should have a coat of paint once every year or two, as this will prolong the life of the equipment and keep it looking new; the cost is very little.

The paint we offer for this purpose is the same quality as that used when the enamel is baked on at the factory, excepting that a metallic dryer (not japan) is added to the paint so that it will air dry.

It is the best gray protective enamel made especially for us under our own formula, based upon thorough investigation, numerous tests and research work for the best enamel for dairy barn equipment.

## James Name Plate

Any dairyman who takes pride in his individual cows, their pedigrees or their records, will find the James Name Plate the most convenient of places on which to display such data; it is also very useful for memoranda relating to the particular cow to whose stall the name plate is attached, such as instructions for feeding.

The plate which we furnish with the frame is black, entirely blank and may be written upon with a slate pencil, the same as upon a slate. The writing may be erased and re-written.

Easily and quickly attached to either the steel or the wood stalls, or to the cow pens or bull pens. When ordered for pens, size of pipe to which the name plate frame is to be attached, must be given, in order that proper clips may be sent. Finished, battleship gray enamel, baked on.

State whether to be used on stalls or pens and to what it is to be attached—wood or steel. If steel, give size and state whether round or square.



## Dairy Scales

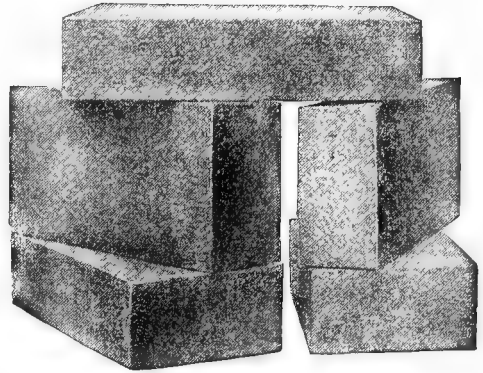


The large circular dial has distinct black figures and graduations marked off by tenths of pounds. By the use of the patented adjustable hand, it is easy to obtain the exact net weight of contents of pail; first get the exact weight of the empty pail, then loosen the screw of the hands and turn the hand back to zero. The result then obtained is the exact weight of the contents of the pail.

Very attractive and durable and of the latest type. Made to comply with the Department of Weights and Measures.

Two sizes—40 and 60 pounds, by tenths.

Guaranteed accurate.



## Cork Brick Flooring

A good floor for cow stalls, calf and bull pens, horse stalls, sheep pens, and piggeries is something that the dairymen and stock raisers of the country have been trying to find for years.

Wood planking is fairly warm and easy on the feet, but it is not sanitary. It soon gets foul and rots out.

Smooth concrete is easy to keep clean, but it certainly is injurious to animals that have to stand or lie on its cold, hard, slippery surface.

Chemically treated wood blocks are liable to get slippery, and frequently expand when exposed to moisture.

To get something that will combine the good and eliminate the bad qualities of these materials, has been in past years a problem.

Cork brick, however, have solved the stall floor problem. They were placed on the market six years ago after numerous tests in actual service had demonstrated merit. That they have satisfactorily fulfilled the claims made for them, is proved by the fact that there are now over 7,000,000 brick installed in approximately 5,000 dairy barns in all parts of the country.

The cork brick make a floor that is thoroughly sanitary, warm to the touch, easy under foot, non-slippery—wet or dry, durable in service, easy to install, and moderate in cost.

Cork brick consist of finely granulated cork and refined asphalt, heated and thoroughly mixed, then moulded under pressure into brick form.

The brick measure 9 x 4 x 2 inches for cow stalls, and 9 x 4 x 1¾ inches for horse stalls. They are laid flat, and four will cover exactly one square foot of surface.

Cork brick meet every requirement for an ideal stall floor; if you are interested, drop us a postal card asking for 32-page booklet, "Better Stall Floors."

## James Alley Gate

This gate is very convenient and useful to prevent cows getting into the feeding alley, when they are entering the barn or being turned out.

The gate locks when slammed shut, but may be opened quickly and easily. When not needed, gate may be swung out of the way.

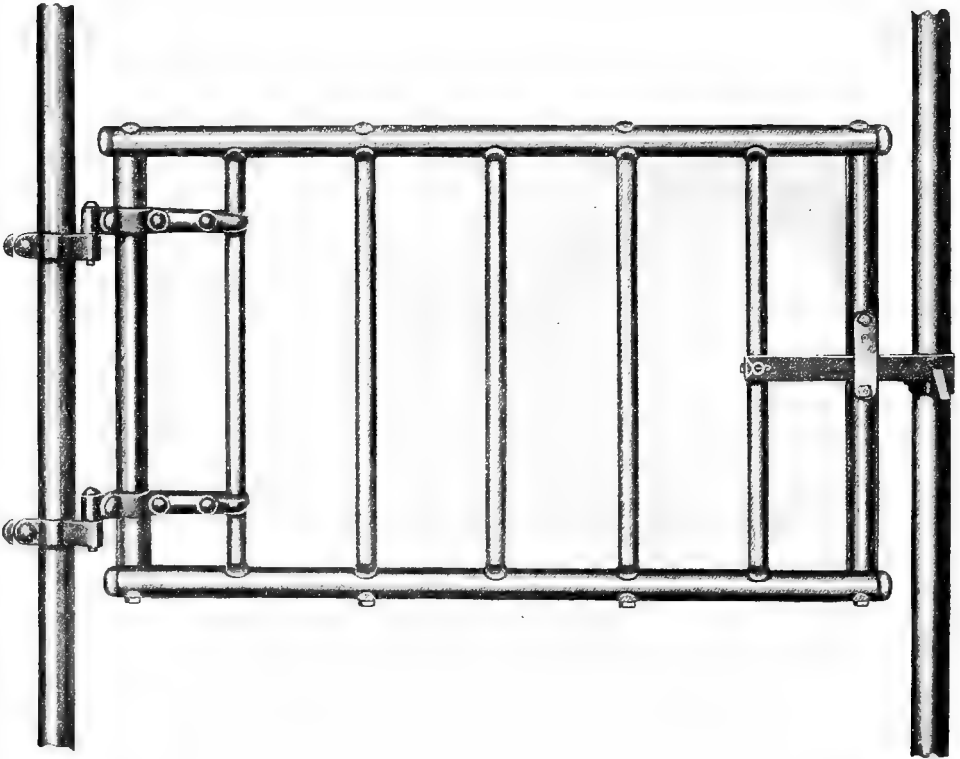
Built of 1 $\frac{1}{2}$ -in. O. D. pipe, with 1 $\frac{1}{8}$ -in. O. D. uprights. Fittings of best malleable. Gravity latch. Malleable offset hinges. Finished in battleship gray.

Gates furnished any size desired, up to 4 feet 6 inches wide. For wider alley, alley chains should be used.

When ordering alley gates, kindly give the exact distance of space to be filled. Measure from center to center of stall end uprights if there are stalls on both sides of alley; measure from stall end upright to wall if alley is at end of barn next to a wall.

If possible, send a small sketch showing location of gate and giving dimensions.

Also state if gate is to be hinged on 1 $\frac{3}{8}$ -in. O. D. or 1 $\frac{7}{8}$ -in. O. D. pipe, and if extra parts are to be furnished with gate.

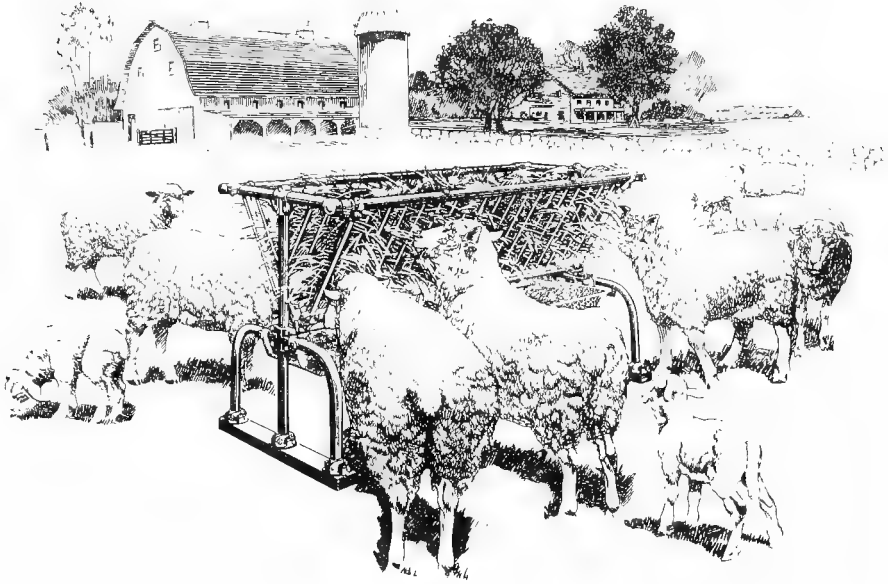


James Alley Gate

## James Alley Chains

When ordering specify to what chains are to be attached, length desired, and number of chains required.

## The James Sheep Feeding Rack

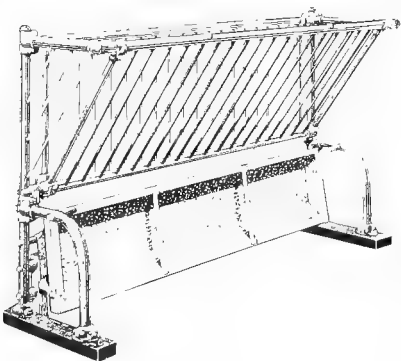


The James Sheep Feeding Rack is proving very popular, not only for the feeding of sheep but also as a calf feeding rack.

The silage or hay is wasted less than by the usual method of feeding; that which rattles down through the spindles of the rack falls in the trough and is eaten.

The trough is hinged, so that refuse may be easily dumped.

This trough may also be used for the feeding of grain.



The uprights at the ends are of  $1\frac{5}{8}$ " O. D. pipe; the frame of the panels is of  $1\frac{1}{16}$ " O. D. pipe; and the spindles are of  $\frac{7}{16}$ " round mild steel; all bound firmly together with fittings of best malleable.

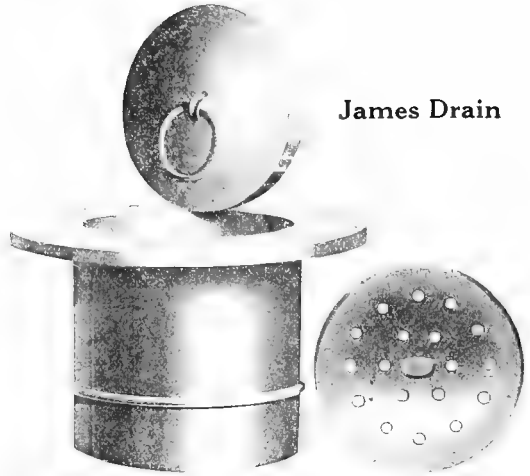
The trough is of 20-gauge galvanized sheet steel, reinforced on the ends with  $\frac{1}{2}$ " x  $\frac{1}{2}$ " x  $\frac{1}{8}$ " angles. Angle iron dividers across the trough are  $\frac{3}{4}$ " x  $\frac{3}{4}$ " x  $\frac{1}{8}$ ".

The base is of yellow pine,  $1\frac{5}{8}$ " x  $3\frac{5}{8}$ ".

## Fittings for Milking Machine

Any of the milking machines can be readily attached to James stalls. The James fittings for this purpose make a sanitary and good looking job and do not interfere with the operation of either stalls or milkers.

We are prepared to furnish any special fittings required for the purpose. Write for further information, stating name of milking machine.



### James Drain

For convenience in draining the manger and gutters when barn is being flushed or washed out. These drains should not be used for the purpose of removing liquid manure. Special traps of much greater capacity should be purchased for that purpose.

Made of cast iron, with ground brass cap to prevent any leakage with a cast iron screen, which may be readily removed for cleaning. Hole is four inches in diameter.

## The James Feeding Basket



Designed especially for use in test pens, and wherever an individual feeding basket is desired.

They are strong and durable, and should give good service for years.

So shaped that they may be nested, thus taking up but little room.

Made of 24-gauge galvanized sheet, 18 inches at top, 16 inches at bottom and 14 inches deep. Capacity about 1½ bushels.

# THE MEN BEHIND THE JAMES WAY



**C. P.  
GOODRICH**  
Pres.

**H. H.  
CURTIS**  
V. Pres.

**W. D. JAMES**  
Secretary and General Manager

# Our Golden Rule Guarantee

**We Guarantee** *not only the quality of material and workmanship, but complete satisfaction with the service of the equipment in actual use if our simple instructions are followed.*

*We make this strong guarantee for mutual protection. If there should be a fault in any of our goods, causing dissatisfaction on the part of the buyer, we could not afford to have him keep the equipment.*

*His dissatisfaction would become our loss. We are, therefore, anxious to return the purchase price to any buyer of our goods who is not fully satisfied, if we are at fault in any way.*

*Remember that this guarantee not only covers the quality of material and workmanship; but the demonstration in your own barn must prove our claims of superiority or we want the goods, and you get your money back if you have paid for them.*

**OUR TERMS:** *Net Cash. No Discounts.*

*This guarantee applies to every equipment, no matter whether purchased from us direct or through our representative. We make it good direct to you in either case.*

**JAMES MANUFACTURING CO.**

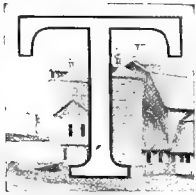


*C. P. Goodrich*  
President

*H. N. Curtis*  
Vice-President

*H. D. James*  
Secretary & General Manager

# Introducing the Men Behind the James Way



HIS catalog tells the story of the profit-making James Way of caring for dairy cattle in the barn—points out how sanitary conditions may be maintained—how feed may be saved—how losses through wasteful methods of doing the barn-work may be stopped.

Some of the statements may seem to the uninformed almost too good to be true; and that you may know something of the men who make these statements and who stand back of the James "Golden Rule" guarantee we ask you to read the brief history of these men which follows, and of the concern whose affairs they direct.

Read, too, the letters from satisfied customers in various sections of the book, and glance over the partial list of well-known men who have honored us with their business.

Then study the pictures which appear on pages 6, 8 and 9 showing the remarkable growth of the business.

Having done this, you will not doubt us when we say that we are in this business with a sincere desire to aid in the upbuilding of the dairy industry of the country and to help the average dairy farmer improve conditions in his barn and secure greater money rewards for his labor.

## The Men

The President of the company is Charles Perry Goodrich, well known to dairymen throughout the United States as having devoted a long life to the dairy business and to the improvement of dairy conditions.

His work as an instructor and lecturer in farmers' institutes in many states, and as a writer on dairy subjects, has made his name familiar to those interested in dairying. He is one of the few men in America who has received a testimonial from the University of Wisconsin on account of "Services rendered to agriculture and related branches."

As indicated in the testimonial, Mr. Goodrich's services were along dairy lines; and as the president of the James Mfg. Co., he is still in the work of bettering conditions in that great industry.

Mr. Goodrich is also Vice-President of the Northwestern Mfg. Co., known everywhere for their high standing in the manufacture of superior buggies and carriages.

Mr. H. H. Curtis, our Vice-President, is engaged in large business enterprises and is also in the dairy business in a practical way, operating a dairy farm near Ft. Atkinson and dealing in registered and graded dairy cattle.

He is well known at home and abroad as a successful business man in the best sense of the term.

Mr. W. D. James, our Secretary and General Manager, scarcely needs an introduction to any dairyman who is at all familiar with current improvements in dairy barn building and equipment.

His name is associated inseparably with progress in dairy barn architecture and in methods of handling dairy barn work. He is regarded by leading dairymen throughout the country as an authority on dairy barn construction.

The barn adopted some years ago by the Wisconsin State Board of Agriculture as the model dairy barn at the Wisconsin State Fair Grounds, is familiar to all who have attended that fair and to many others who are readers of the dairy and agricultural press.

Mr. James' plans were chosen as the best from those submitted in open competition by architects and other experts.

In the years that have passed since this first public recognition of the worth of his idea in barn designing, Mr. James has designed hundreds of the largest and most practical dairy barns of the country; thousands of other barns, both large and small, have been built from plans drawn under his direction; and other thousands of barns have been remodeled in accordance with his suggestions and plans.

Prominent dairymen from coast to coast seek his services. It is the good fortune of the patrons of this concern that Mr. James is associated with us, for every buyer of our barn equipment is given the benefit of his special knowledge and long experience in barn designing.

Mr. James was born and raised on a dairy farm; and as a boy and man became thoroughly familiar with the business of dairying. His genius as an inventor has solved and is solving many of the problems and difficulties of the business, making the life of the average dairyman easier and dairy profits bigger.

## The Company

Although the company is comparatively young, having been organized under the laws of Wisconsin in 1906, its growth has been very rapid, until now it has an authorized capital stock of \$500,000.00.

The real beginning, however, was back on the James farm near Wales, Wis., where the first James stalls were made in the old blacksmith shop on the farm. Later, more stalls were made in the village near by.

One day it happened that Mr. C. P. Goodrich saw the "new-fangled" stall in use on a farm where he was visiting, and so impressed was he with its sanitary features and labor saving devices that he drove over to see the inventor.

As a result of the acquaintance thus begun, a company was organized to handle the proposition on a large scale and the business moved to Ft. Atkinson.



At this stage of the history of the business, one man constituted the entire factory force, one girl handled the office work, and the manager, Mr. James, worked part time in the shop, part time in the office and part time out on the road selling the product of the little factory.

Progressive dairymen quickly realized the value of equipment that would help keep their barns clean and that would lessen barnwork; and within a couple of years a very satisfactory little business was established.

From that time on, however, the business grew so fast that it was difficult to keep pace with it in shop and office. Scarcely a year has gone by that additions to the factory building have not been made to take care of the increased output.

From year to year, huge machines were added to the plant to take the place of hand work, to make more perfect the workmanship and to lessen the floor space needed; nevertheless each year more men and a bigger factory were required.

From the very first "Service" has been the keynote of the business.

Not only has Mr. James given much time and thought to working out new inventions that would lessen labor and improve sanitary conditions in dairy barns; but under his direction, other men with inventive genius and experience in the dairy business, have been developing and testing out ideas that promise a betterment in barn methods.

In connection with this work, an experimental department was established some years ago. Before new equipment is offered to the public, it is put through many tests to determine its practical worth and strength; the final test being actual use in severe service in the James Experimental Barn, a picture of which appears on pages 280 and 281.

When any James equipment or device is offered, you may be sure that it has been proven satisfactory in actual use and that it will fulfill perfectly all requirements. James Equipment is not built on theory.

A Barn Planning Department was early established for the benefit of customers and prospective buyers of James Equipment, with a staff of competent architects and draftsmen. This makes it possible for us to give everyone the benefit of Mr. James' experience and special knowledge of what is best and most practical in barn building.

If you intend to build a barn, or remodel one, you are cordially invited to come to Fort Atkinson, visit the Experimental Barn and other barns in this vicinity then talk over your plans with our Barn Planning staff. Perhaps they can help you just as they have helped thousands of other dairymen. In any event, you will be under no obligation to buy of us—we shall be glad to give you the benefit of our advice and counsel on barn planning whether you buy James Equipment or not.

# Partial List of Users of James Equipment

## ALABAMA

Allenville  
Birmingham  
La Fayette  
Mobile

Orrville  
Ozark  
Seale  
Summerdale  
Tuscaloosa  
Tuskogee

## ARKANSAS—

Brinkley  
Elkins  
Fayetteville  
Little Rock  
Scott  
Stuttgart

## CALIFORNIA —

Escalon  
Glen Ellen  
Hopland  
Napa  
Sacramento  
Santa Anita  
San Francisco

Santee  
Stockton

## CONNECTICUT—

Bloomfield  
Cheshire  
Danbury  
East Haven  
Greenwich  
Groton

Hartford  
Litchfield

Long Hill  
Meriden  
Middletown  
New Haven  
New Milford  
Storrs  
Windsor

## DELAWARE -

Georgetown  
Wilmington

## FLORIDA—

Bradford  
Hastings  
Lake City  
Lemon City  
Muscogee  
Tallahassee  
West Palm Beach

## GEORGIA—

Americus  
Columbus  
Savannah  
  
Warthen  
Waynesboro

## ILLINOIS—

Bartlett

Cottonwood Plantation  
Robert Jameson, Jr.  
Charles Schuessler & Sons  
Clove Creamery  
Episcopal Church Home  
Wm. P. Tunstall  
Van Antwerp Drug Co.  
J. E. Dunnaway  
J. D. Halman  
C. R. Dudley  
B. J. Sullivan  
Alabama Insane Hospital  
Tuskogee Normal & Industrial Institute

H. L. D. Whitson  
D. T. Boone  
H. C. Porter & Sons  
W. L. Terry  
T. W. Steele  
Young's Poultry and Dairy Farms, O. M. Young, Prop.

A. B. Humphrey  
Jack London  
A. W. Foster  
California State Hospital  
A. Meister  
Anita Baldwin  
James Rolph, Jr., Mayor of San Francisco  
Edgemoor Farm  
California State Hospital

T. C. Perkins, Broker  
Cheshire Reformatory  
Philip Seelig  
John Howe  
T. L. Chadbourne, Jr.  
Branford Farms—Morton F. Plant  
Watkinson Farm School  
F. E. Duffy  
Echo Farm  
Falcon's Flight Farm—Dr. B. Austin Cheney  
J. Arthur Sherwood  
J. Hobart Yale  
Daniels Brothers  
Ex-Gov. R. S. Woodruff  
A. G. Barnes  
Conn. Agricultural College  
Loomis Institute

Andrew Marvel  
Coleman DuPont  
H. S. Haskell

State Prison Farm  
Florida Vegetable Co.  
North Florida Dairy Co.  
Dr. J. G. Du Puis  
Oscar Williams  
Florida College for Women  
Taxahatchee Farms

Arles Plantation  
E. P. Owsley  
State Normal & Industrial School  
J. H. Hooks  
R. C. Neely

. . . Haeger, Holsteins  
S. P. Stevens, Reid, Murdock & Co.

## ILLINOIS—Continued

Champaign  
Chester  
Chicago

Colfax  
Davis  
Des Plaines  
Dolton  
Elgin

Hampshire  
Hinsdale  
Jacksonville  
Lake Forest  
Lake Villa  
Lisle  
Oregon

Pekin  
Peoria  
Rockford  
Streator  
Tehny

## INDIANA—

Auburn  
  
Brooklyn  
Brookville  
Crown Point

Elkhart  
Evansville  
Fort Wayne

Goshen  
Indianapolis  
Kokomo  
Lafayette

La Porte  
  
Logansport

Madison  
Marion  
Martinsville  
Michigan City  
Mishawaka

New Carlisle  
No. Manchester  
Petersburg  
Rockville  
South Bend

Terre Haute

Warren

## IOWA—

Albion  
Algona

Anamosa  
Arlington  
Britt  
Charles City  
Cedar Rapids

Capt. J. R. Trevett  
State Hospital  
Union Stockyards & Transfer Co.

H. W. Gossard. Gossard Corsets

Ralph Wilder, Cartoonist  
Oliver Story  
Wesley M. Sarver  
St. Mary's North Farm  
Dr. C. H. Thompson  
Smith Youngs, Holsteins  
A. H. McCormick  
C. E. Chappell  
Preston Bellows

T. E. Getzelman, Holsteins  
C. A. Tousey  
Deaf and Dumb School  
Mrs. Scott Durand  
O. W. Lehmann  
Joy Morton  
Col. F. O. Lowden, Sissippi Farm  
S. D. Low  
State Hospital  
C. Herbert Lewis  
Sass Bros.  
Society of the Divine Word

Geo. W. Rakestraw  
J. W. Sheffer  
Black & Adams, Jerseys  
Morris M. Thompson  
C. E. Benjamin  
Lake County Poor Farm  
August Neuenfeldt  
John Houseworth  
Southern Hospital  
Indiana Home and Training School for Feeble Minded Youth

W. Showalter  
Howard Johnson  
Sylvester Bell  
St. Anthony's Home  
Purdue University  
W. C. Weir  
Alden H. Herrold  
Northern Hospital for Insane  
W. W. Moss & Son  
Southeastern Hospital  
W. G. Bradford  
Van Camp Packing Co.  
Walter J. Bull  
John H. Fulmer  
Clarence Fulmer  
Clem Fulmer

E. H. Studebaker  
D. C. Harter  
W. E. Lamb, Guernseys  
Indiana Tuberculosis Hospital  
Notre Dame University  
St. Mary's Academy  
E. L. Kelsey  
E. H. Studebaker  
The Rose Orphans Home  
Chas. Whitcomb, "Sleepy Hollow Farm"  
Methodist Memorial Home

Geo. F. Reidel  
Bert McCorkle  
W. K. Ferguson  
State Reformatory  
Harrie W. Gleim  
John Hammill  
M. F. Schlick  
Wm. Ford  
Wm. T. S. Bear

PARTIAL LIST OF USERS—Continued

IOWA—Continued

Cedar Falls Dr. Thos. Y. Kane  
 Clyde Bechtelheimer  
 J. O. Scheff  
 C. Schuler  
 J. R. Lane. Iowana Farms  
 Old People's Home  
 Mountain Bros.  
 Des Moines St. Mary's Orphans' Home  
 Dubuque Gus. Hesselman  
 Dyersville C. A. Lundy. Lawyer  
 Eldora State Industrial School  
 Fayette Fayette County Home  
 Fenton A. A. Dreyer  
 Fredericksburg L. E. Fay  
 Ft. Dodge L. E. Armstrong  
 Senator Fred Larabee  
 Fillmore S. S. Budlong  
 Glenwood State Hospital  
 Granger Dale Meek  
 Hampton Roemer-Gibson Farm  
 Hawkeye A. L. Eitel  
 Inwood Henry Sterkens  
 Mason City Heeler Bros.  
 McGregor F. Kadlec  
 Mitchellville W. P. McDonald  
 Orange City Otto Van Roekel  
 Osage W. D. Runge & Sons  
 Preston John Grant  
 Pomeroy John Featherstone  
 Rolfe Louis Nemecek. Dairyman  
 Sioux City J. W. Kennedy  
 Staceyville Nick Theobald  
 Storm Lake Sac City Canning Co.  
 Sumner Walter Thompson  
 Cass Farm Co.  
 Sutherland Mrs. R. C. Jordan  
 Waukon County Poor Farm  
 Waterloo Galloway-Messer Farms  
 Winterset Flora E. Harris

KANSAS—

Denison David Coleman  
 Ossawatomic State Hospital  
 St. Mary's St. Mary's Academy  
 Topeka State Hospital  
 Industrial Educational Institute  
 J. W. Bigger  
 O. E. Walker

KENTUCKY—

Berea Berea College  
 Lincoln Institute  
 Frankfort Kentucky Institute of Feeble  
 Minded Children  
 Jenkins J. W. Ellis. Elkohn Dairy  
 Louisville A. E. Norman  
 Nicholasville Everett B. Hoover  
 Versailles J. N. Camden

LOUISIANA—

Alexandria W. E. McFarland  
 Jos. Sterx  
 Homer Dr. L. E. Morgan  
 Marksville C. C. Gaspard  
 New Orleans Lawrence Faubacher  
 Opelousa State Normal School  
 Raceland Clotilda Plantation  
 Reserve Godchaux Belle Pointe Dairy  
 Slidell G. O. Journey

MAINE—

Auburn C. E. Waterman & Sons  
 Augusta Maine State Hospital  
 Bangor City Farm Barn  
 Davidson Ora Gilpatrick—Summit Farm  
 Detroit John F. Longley Sons Co. Inc.  
 Island Falls Delmont Emerson & Son  
 Orono University of Maine  
 Pownal Maine School for Feeble-  
 Minded  
 Skowhegan Blin W. Page—Banker

MAINE—Continued

Wells Chas. E. Lord & Sons—Laud-  
 holm  
 Yarmount Ralph P. Redfern

MARYLAND—

Augusta State Hospital  
 School for Feeble Minded  
 City of Baltimore  
 C. H. Basshore  
 Endowment Hospital  
 Rosewood State Training  
 School  
 Dr. J. I. France  
 T. Roy Brooks  
 U. S. Experimental Farm  
 C. A. Spitznas  
 M. P. Moeller. Organ Mfgr.  
 Queenstown The Hermitage  
 Rockville J. H. Bradley  
 Sudlersville R. Bruce Massey  
 Warton J. E. Morris

MASSACHUSETTS—

Ashby J. P. Lyman  
 Attleboro J. L. Sweet  
 Boston Brighton Stock Yards—400  
 stalls  
 W. B. H. Dowse  
 H. P. Hood & Sons  
 Cherry Hill Farm, Beverly  
 Bonnie Brook Farm, So.  
 Sudbury  
 P. B. & R. S. Bradley  
 George Ellis  
 Maxwell Norman  
 C. H. Jones. Pres. Common-  
 wealth Shoe Co.  
 Rev. O. W. Means  
 Brookfield Oaks Farm—C. W. Barron,  
 Cohasset Prop  
 Framingham N. I. Bowditch  
 Great Barrington Brookside Farms  
 Groton F. L. Howes  
 Hardwick Mixer Farm—J. S. Clark,  
 Supt. Guernseys  
 Holyoke W. F. Whiting  
 Ipswich F. P. Frazier & Son—Upland  
 Farms  
 R. T. Crane  
 Lancaster Industrial School for Girls  
 Mansfield Walter M. Lowney—Choco-  
 lates  
 Marion Galen L. Stone—Banker  
 Martha's Vine- Seven Gates Farm—W. L.  
 yard Webb  
 Montello D. W. Field Farm Co.—Hol-  
 steins  
 Oldtown C. A. Gray. Oldtown Canoe  
 Co.  
 Palmer Monson State Hospital  
 Pittsfield Blythwood Farms—John A.  
 Spoor  
 Sherborn Stannox Farm—C. S. Hough-  
 ton  
 Shirley Industrial School for Boys  
 Southboro Deerfoot Farms  
 South Hadley Bonnielea Farm—F. H. Met-  
 calf  
 Springfield F. T. Kellogg  
 Wellesley Hills Academy of the Assumption  
 Westfield State Hospital  
 Whitinsville Arthur F. Whiting. Whiting  
 Mfg. Co.  
 Williamstown G. A. Cluett  
 Worcester W. E. Harmon  
 Worcester A. S. and M. W. Clements  
 W. J. Woods

MICHIGAN—

Allegan Allegan County Infirmary  
 Geo. H. Jewett  
 Aloha Dr. J. B. Patterson

## PARTIAL LIST OF USERS—Continued

## MICHIGAN—Continued

Battle Creek W. M. Wentworth  
Geo. B. Willard  
Belleville Quirk Farms  
Big Rapids Harry Widdicombe, Jr.  
Birch Run Chas. Wolohan  
Cadillac Dr. G. D. Miller  
Charlotte H. W. Hancock  
Clark's Lake C. F. York  
Coldwater Campbell & Angevine  
Detroit Carl E. Schmidt  
W. E. Flanders  
W. E. Scripps  
Dr. R. J. Palmer  
G. L. Spillane & Son  
Dr. Ernest Schemer  
St. Clair Co. Infirmary  
Irving J. Bissell  
A. A. Carroll  
Charles R. Horrie  
P. T. Colgrove  
Hastings Houghton County Infirmary  
Houghton State Tuberculosis Sanitarium  
Howell G. W. Cardwell & Son  
Imlay City Dickinson County Hospital  
Iron Mountain Allen Bros.  
Jackson Jackson State Prison  
Benj. Hanchett  
Jenison H. W. Wigman, Guernseys  
Lansing Home and Training School  
Lapeer L. S. Marshall  
Leslie L. S. Marshall  
Marquette Emblagaard Dairy  
Marshall Dr. J. W. Houston  
Stewart Acre Farms  
Mason Geo. Gillespie, Holsteins  
Newberry Newberry State Hospital  
Niles Ballard Bros.  
Ontonagon Ontonagon County Hospital  
Petersburg Zweigertdale Farms  
Port Huron M. D. Baldwin Estate  
Portland J. M. Maynard  
Saginaw Frank Plum, Guernseys  
Dr. A. S. Rogers  
South Haven G. W. Padbury  
Three Oaks M. G. McGowan  
Traverse City Traverse City State Hospital  
Ypsilanti J. E. Warner

## MINNESOTA—

Albert Lea Will Jensen  
Albertville Herman Berning  
Amboy Adolph Herlick  
Anoka A. D. W. Johnson  
Austin Mrs. A. V. Ellis  
Belview E. G. Enestvedt  
Bemidji D. R. Gilmore  
Blue Earth Fox Brothers  
Buffalo Lake Roy Verhoffer  
Caledonia Wheaton Brothers  
Courtland Otto Berbrich  
Cottonwood C. J. Reimstad  
Martin Halstad  
D. D. Tenny  
Crystal Bay Edw. Osmundson  
Dauson Neil McKay  
Delhi S. O. Sheggeby  
Echo Wilbur Brown (State Demon-  
Fairmont stration Farm)  
Martin County Poor Farm  
J. R. Thompson  
James O'Conner  
Granite Falls Chas. Lundgren  
Gibbon C. O. Gilfillan  
Gilfillan B. H. Jacobson  
Hadley Otto Siercks  
Hammond L. K. Rowberg  
Hanley Falls Chamberlain Brothers  
Hastings Nelson Brothers  
Hector C. J. Victor  
Hendricks Emil Thompson  
Hills J. N. Jacobson  
A. Bruins  
Holland Ben H. Ashley  
Jackson John Leibhard  
Jordon

## MINNESOTA—Continued

Lake Crystal T. C. Norman  
Lakefield Frank Schult  
Lakeville Charles Neary  
Lake Benton Hans P. Christiansen  
Lamberton J. C. Johnson  
Madelia Albert Teigiem  
Mankato Dr. W. A. Beach  
J. W. Schmitt  
Louis Brunz  
Mapleton N. W. Freeze  
Marshall White Bros.  
Lewis Springer  
Millville Eugene Truax  
Milroy Charles Gold  
Minneapolis G. H. Rogers  
A. S. Josephson  
A. J. Ringeisen  
Monroea Crone Bros.  
Monterey Louis Compart  
New Ulm R. F. Compart  
Nicollet Jacob Telgen  
Ormsby P. C. Falkum  
Ostrander Leach & Leach  
Owatonna Geo. Ruel  
Rob. Crickmore  
Pemberton W. C. Pagenkopf  
Pipestone U. S. Indian School  
Red Wing E. H. Langhams  
Redwood Falls Andrew Stewart  
Mrs. R. E. Fuller  
Joseph J. Fisher  
Robt. Tetrick  
Robt. Stewart  
Dr. Thos. Flinn  
G. H. Johnson  
Rochester Dr. Mayo  
State Hospital  
John Brandt  
Sanborn Henry Ott  
Sherburne Berkner Bros.  
Sleepy Eye Geo. Moll  
O. J. Anderson  
Spring Grove Michael Skow  
Springfield F. J. Isaksey  
E. J. Brosius  
St. Charles Thomas Frisby  
St. Paul Walter Hill, Farm at White  
Bear, Minn.  
George Slade, Vice-President,  
N. P. R. R.  
J. W. Bonngard  
W. W. Dunn, Jr.  
Knut Knatterstad  
Storden S. P. Hicks  
Tracy E. B. Gillis  
Tyler Jacob Jacobson  
H. M. Peterson  
Virginia Cusson & Rogers  
Wabasha Peter Buol  
Winona Lewis Oech  
Waseca Mrs. Geo. H. Wood & Son  
Henry Lewer  
Johnnie Lewer  
Walnut Grove F. L. Marriott  
Woodstock Dennis Hennessey  
Woodlake M. F. Ahrend  
C. E. House  
Wirthington O. H. Nystrom  
Windom Redding & Redding  
Zumbro Falls Ed. Lynch

MISSISSIPPI—  
Goodman Holmes County Agricultural  
High School  
Lumberton A. A. Pigford  
Macon H. B. Gurler  
Purvis James Hand, Jr.

MISSOURI—  
Aurora T. E. McClure  
Conception Conception Abbey  
Crescent John T. Milliken  
P. P. Lewis, Pres. of Missouri  
State Board of Agriculture

PARTIAL LIST OF USERS—Continued

MISSOURI—Continued

Eureka Tom Shields, Certified Milk  
 Glencoe La Salle Institute  
 Liberty Odd Fellow's Home  
 Marionville H. L. Doggett  
 Maysville S. W. Cook & Sons  
 Palmyra Head & Gray  
 St. Charles H. F. Finck, Dairyman  
 St. Louis A. A. Bright  
 August A. Busch, Brewer  
 Wm. J. Lemp, Jr. Brewer  
 E. A. Lemp, Brewer  
 Pevely Dairy Co.

MONTANA -

Bozeman Montana School for the Blind  
 Butte The Hennessey Mercantile  
 Co  
 Helena Helena Hostein Fresian Co.  
 Hobson Thos R. Murray  
 Miles City C. H. Loud, State Industrial  
 School  
 Missoula Joseph M. Dixon  
 Wibaux W. A. Orgain Co.

NEBRASKA -

Ingleside Nebraska State Hospital  
 Lincoln H. A. Young  
 State University  
 Norfolk State Hospital  
 Omaha L. E. Sabine  
 H. C. Langan

NEW HAMPSHIRE—

Bennington Arthur J. Pierce  
 Campton J. C. Haartz, Albamont Farms  
 Center Barnstead J. D. Hymers  
 Concord New Hampshire State Hos-  
 pital  
 Center Conway J. W. G. Walker  
 Dixville Notch Balsams Stock Farms  
 Georges Mills Billy B. Van  
 Peterboro Ex-Governor R. P. Bass  
 Old Town Farm  
 Raymond F. W. Falconer  
 Sanbornton Chas. H. Tyler  
 Westmoreland Hall Brothers  
 Wilton D. Whiting & Sons

NEW JERSEY -

Bernardsville Knollcroft Farms  
 Wendover Farms, Walter P.  
 Bliss, Owner. L. E. Ortiz,  
 Supt.  
 Hamilton Square J. E. Burtis  
 Millington Norman Schultz  
 Morristown Morristown Hospital  
 Livingston Whitney  
 L. E. Niese, Jr.  
 Mountainville Houghton Farms  
 Plainsboro Walker Gordon Laboratories  
 Saddle River Geo. M. Eckert  
 Salem Issac Bacon  
 Sussex Belle Ellen Stock Farms  
 Vineland Training School

NEW MEXICO—

Albuquerque Rio Grande Industrial School

NEW YORK—

Albion Joseph Harding  
 Amboy Carlsruhe Farms, Holsteins.  
 Amsterdam Stephen Sanford Co.  
 Francis Morris  
 Angelica James Young  
 Floyd H. Scholes  
 Auburn D. M. Dunning  
 H. R. Wait Co  
 Avon Markham & Puffer  
 Babylon David Gardiner  
 Baldwinsville Robert Melvin, Holsteins  
 Barrytown Rokey Farms

NEW YORK—Continued

Batavia Walker & Priest, Real Estate  
 George A. Bridge  
 W W Hawley, Jr.  
 Bedford Hills State Reformatory for Women  
 Henry W. Howe, Guernseys  
 Belvidere Belvidere Farms  
 Binghamton Broome County Almhouse  
 Wm. Hotaling (Mgr. Hillcrest  
 Farm)  
 Bliss Lowe Brothers  
 Broada'bin Mrs. Robert W. Chambers  
 Brookton Dr. V. A. Moore (Veterinarian  
 Cornell University)  
 Buffalo Dr. Geo. M. Jack  
 Country Club  
 Wm. A. Williamson  
 Edmond Hayes  
 Fred S. Knaisch  
 Jefferson Penn  
 Eugene D. Hofeller  
 Spencer Kellogg  
 F. D. Moody  
 Canajoharie Fred Anderson, Guernseys  
 Carthage S. R. Strickland, Holsteins  
 Cazenovia Henry Burden  
 Chas. Fairchild  
 Dudley Hartt  
 William Phillippi  
 Chaffee Geo. Lacy  
 Chateaugay Geo. Winter & Son  
 Timothy Dwyer  
 Chatham W. P. Hawley  
 Claydon May Irwin, Actress  
 Cleveland Vandercamp Farm  
 Clinton Francis M. Jones, Holsteins  
 Clinton Corners Webb Farms  
 Collins Gowanda State Homeopathic  
 Hospital  
 Cold Spring Har- Walter Jennings  
 bor Clark Estate, Singer Sewing  
 Cooperstown Machines  
 Copenhagen F. M. Lansing  
 Corning W. T. Smith  
 Cortland W. H. Mace, Holsteins  
 O. W. Kellogg  
 Jerry Bades  
 Coxsackie Rev. Lewis Lampman  
 Earlville Borden Condensed Milk Co.  
 East Aurora S. H. Knox Estate  
 J. T. Shanahan  
 George R. Beardslee  
 Borden Condensed Milk Co.  
 Samuel Powers  
 East Creek  
 Edmeston  
 Essex  
 Fishkill-On-the  
 Hudson J. B. R. Verplank  
 Fort Plain V. S. Bauder  
 Friendship F. R. King  
 Fulton Elmer E. Taylor, Holsteins  
 Gainesville L. S. Duggan  
 Glen Cove Estate of Chas. Pratt  
 Glen Falls John R. Loomis  
 Gouverneur Geo. H. Partridge  
 Earl Laidlaw  
 Grand Gorge Chas. J. Dent  
 Hamilton A. A. Hartshorn  
 Prof. E. W. Smith  
 Jewish Aid and Protectors  
 Estate of E. H. Dollar  
 F. H. Thomson & Son  
 Hopewell Jct. Henry Morgenthau, Jr.  
 Houghton Pilsby & Fancher  
 Houghton Seminary  
 P. E. Barrett  
 Arthur W. Kettle  
 M. Anderson  
 Henry Stevens & Son  
 Lacona L. L. Lawson  
 La Grangeville J. C. Weil  
 Lancaster Mrs. Jacob Zollar  
 Little Falls Wm. Van Valkenberg  
 Liverpool Syracuse Sale & Pavilion Co.  
 W. W. Stephens  
 R. J. Stephens

## PARTIAL LIST OF USERS—Continued

## NEW YORK—Continued

Locust Valley Kaintuck Farms  
 Lowville E. S. K. Merrell  
 Malone H. W. Spencer  
 Franklin Co. Home  
 David & Jones, Holsteins  
 Mapleview H. M. Dunham, Holsteins  
 Marcellus Supplee Dairy  
 Mayville A. B. Sweetland  
 R. L. Saddle  
 Middletown Jno. Arfman  
 Millbrook Crawford Farms  
 Millerton F. A. Hotchkiss  
 Mohawk Theo. D. Robinson  
 Montgomery Julius Schmidt  
 New Windsor Mrs. Peter Cooper Hewitt  
 New Woodstock J. A. Staunton & Son  
 John Freeborn  
 New York City Eben Richards  
 H. E. Tener  
 John D. Rockefeller  
 Metropolitan Life Ins. Co  
 City Reformatory  
 G. C. Comstock  
 Phenix Cheese Co.  
 E. T. Holmes  
 Ralph Pulitzer  
 Ambrose Monnel  
 Wm. H. Bonyng  
 Frederick A. Southworth  
 W. R. Wood  
 A. L. Page & Sons  
 Sheffield Farms  
 North Syracuse Alfred Ferguson, Holsteins  
 George Ferguson  
 Ogdensburg Major Wm. H. Daniels  
 J. Frank Sharp  
 Dr. A. D. Fisher  
 St. Lawrence State Hospital  
 Women's Relief Corps Home  
 Oxford Paul T. Brady, Vice-Pres.  
 Pawling Westinghouse Co.  
 Perrysburg J. N. Adam Memorial Hos-  
 pital  
 Philadelphia F. L. Ronas, Holsteins  
 Plattsburg Judge H. T. Kellogg  
 C. B. Billings  
 Poland W. D. Robbins, Holsteins  
 Potsdam Wells & Wells  
 Horace N. Clark  
 Preble A. A. Knapp & Son, Holsteins  
 Randolph Walker & Bull  
 Children's Home  
 Geo. C. Hubbard  
 Red Hook E. T. Jenkins  
 Rensselaer Falls Geo. J. French  
 Rochester D. M. Beach  
 Wm. B. Hale  
 C. L. Whitney  
 A. T. Fanchier  
 W. C. Hoag  
 Salamanca Wm. Slayter, Holsteins  
 Sayville, L. I. Lewis Shopmeyer  
 Schenectady Frank Berning  
 Harrison Crocker & Son  
 Sennett Kutchbach & Sons, Holsteins  
 Sherburne E. J. Ballinger  
 Sherman H. C. Howes  
 Geo. B. Hiscock  
 Skaneateles D. D. Decker  
 So Dayton Frank M. Smith  
 Springfield Ctr. Hon. Lathrop Brown  
 St. James, L. I. F. C. Soule & Sons  
 Syracuse John R. Clancy  
 Syracuse University  
 John S. Conway  
 C. L. Amos  
 Leroy B. Williams  
 W. A. Eastabrook  
 John B. Tuttle  
 Claude E. Trindler  
 A. L. Brockway, Architect  
 Irving Dillaye Vann  
 J. H. Gallup, Warner Quinlan  
 Asphalt

## NEW YORK—Continued

Ticonderoga I. C. Newton Estate  
 Utica W. H. Udall, Cornell Univ.  
 J. B. Stetson, Stetson Hats  
 Quentin McAdam  
 Linn Kinne  
 Brothertown Farms, Holsteins  
 Wm. Martin  
 Fred W. Sessions  
 Sanford F. Sherman, New  
 Hartland Canning Co  
 Borden Home Farms  
 Thos. Burns  
 Watertown D. C. Middleton  
 Geo. N. Smith  
 C. B. Alverson  
 Lansing Estate  
 Westfield Dr. C. E. Welch, Mfg. Grape  
 Juice  
 White Plains Howard Willetts, Gedney  
 Farms  
 Whitehall Geo. Ward  
 Wilton Metropolitan Life Ins. Co

## NORTH CAROLINA—

Asheville J. M. Horner  
 Greensboro State Normal School  
 Hamlet T. N. Battley  
 Newton R. L. Shuford  
 Raleigh State Hospital  
 State A. & T. School  
 Reidsville Jeff Penn  
 Rockingham Pauley Long  
 J. F. Diggs  
 Tillery N. C. State Farms

## NORTH DAKOTA—

Burlington M. D. Graham  
 Bismark U. S. Indian School  
 Bisbee C. P. Peterson  
 Buxton O. J. Sorlie  
 Courtenay Clara Cooper Farms  
 Devil's Lake C. E. Gray  
 Ellendale Estate of Geo. Baldwin  
 Fargo State College  
 Fessenden T. L. Beiseker  
 Grand Forks J. Dobmeir  
 Hankinson John R. Jones  
 Jamestown State Hospital for Insane  
 Litchville Thos. Casey  
 McArthur A. L. Barron  
 Minot E. S. Person  
 Peter Ehr  
 Wm. Ehr  
 Monango W. L. Caldwell  
 Mooreton Wallace Manikowski  
 New Salem Frank Gaebbe  
 Philip Blank  
 Valley City Dr. J. Van Houten

## OHIO—

Akron Rev. S. E. Martin  
 F. A. Seiberling, Goodyear  
 Rubber Co.  
 G. M. Stadelman  
 Alliance O. F. Transue  
 Athens State Hospital  
 Barborton Ohio C. Barber, Pres. Dia-  
 mond Match Co.  
 Bellevue Herbert Wright  
 Bear Lake Dr. H. J. Phillips  
 Benga Knox Co. Infirmary  
 Canal Dover F. A. Alleshouse  
 H. W. Streb  
 Canton Homer V. Briggie  
 Centerville E. S. Reynolds  
 Cincinnati Scarlet Oaks Sanitarium  
 Wm. Gerst  
 James Duncan  
 Chas. Moeser  
 Cleveland Telling, Belle Vernon Co.  
 S. L. Mather  
 Frank Rockefeller  
 O. P. & M. J. Van Swearingen

## PARTIAL LIST OF USERS—Continued

## OHIO—Continued

Cleveland Cooley Farms. City of Cleveland  
 Bird's eye Farms, Frank Guffey, Prop  
 Clyde D. N. Postlewaite  
 Columbus New York Coal Co  
 Dayton W. V. Finch, Jersey Farm,  
 L. T. Cooper Farm  
 E. A. Deeds  
 E. S. Reynolds  
 (farm at Centerville)  
 Robert J. Blackburn  
 Sam Berkebile & Son  
 Preble Co. Children's Home  
 S. J. Bingham & Son  
 R. J. Christy Farm Dairy  
 J. P. Walker, Woodbine Farm  
 W. E. Dalbey  
 H. C. Lewis  
 John D. Hervey  
 Fred W. Floding  
 James McKenzie  
 East Brothers  
 H. L. Solomon & Co  
 Moire Bros.  
 New Prison Farm  
 French Bros. Bauer Co  
 Lawrence Paumier, Holstein  
 Breeder  
 Ohio State Reformatory  
 W. C. Curtis  
 W. C. Miller, Holstein  
 Breeder  
 Sam Lane, (Walnut Valley  
 Stock Farm)  
 R. L. McCorkle  
 J. W. Adams & Son  
 R. H. Morrison  
 Oxford Retreat  
 Jefferson County Infirmary  
 D. K. Stover  
 A. W. Green

## OKLAHOMA—

Elkton D. T. Boone  
 Millerton Wheelock Indian Academy  
 Okmulgee W. Thornbergh  
 Tulsa Frank Gillespie

## OREGON—

Scappoose Fred Uhlman  
 Gaston W. K. Newel  
 Pullman J. D. Carson  
 Union Joseph Farmers

## PENNSYLVANIA—

Abbingtown E. A. Henkel  
 Allentown Col. H. C. Trexler  
 Altoona John Lloyd, Banker  
 R. C. Burns  
 J. J. Stuber  
 Beaver Falls H. S. Snyder, Vice-Pres.  
 Bethlehem Bethlehem Steel Co.  
 C. A. Buck, Vice-Pres. Bethlehem Steel Co.  
 David Wilson  
 Berwyn A. J. Rapp  
 Bradford Jos. R. Grundy  
 Bristol Mrs. W. B. Saunders  
 Bryn Mawr C. Biehl & Sons  
 Butler L. M. Marble  
 Canton J. P. Scott  
 Carnegie Joseph Fox  
 Carrolltown C. A. Buck  
 Center Valley A. P. Irwin, Real Estate  
 Chadds Ford Jct. R. H. Dutton  
 Colmar T. S. Cooper & Son  
 Coopersburg T. D. Adams  
 Cornell John Hammond  
 Corry John F. Stone  
 Coudersport State Hospital for the Insane  
 Danville Frank Graham Thompson  
 Devon

## PENNSYLVANIA—Continued

Doylestown National Farm School  
 Ebensburg Webster Griffiths  
 Edinboro Edinboro Lake Farm  
 W. L. Fellows  
 E. L. Hotchkiss, Vinita Farms  
 F. F. Loop  
 J. C. McClure  
 S. G. Graybill, Holstein  
 Breeder  
 James Hutchinson  
 B. H. Throop  
 W. B. Wickersham  
 T. R. Palmer  
 A. W. Milne  
 E. H. Mack  
 C. L. Thompson  
 F. B. Downing  
 Wm H. Forster  
 Joseph E. Throop  
 W. E. Porter  
 Dr. Vallie Hawkins, Jerseys  
 J. B. Moore & Sons  
 Mission Home  
 Frank Pardee  
 Hershey Chocolate Co.  
 McKelvey Bros.  
 J. M. Delozier  
 T. B. Clark  
 W. H. Tomb  
 John C. Ogden  
 John H. Stephens, Lawyer  
 Jas. McDade  
 Edwin Phillips, Pres. American Road Mach. Co.  
 Industrial School for Boys  
 J. S. Lead  
 S. M. Root  
 Hynicka Bros.  
 A. P. Musick  
 Delchester Farms  
 Sterling & Graham, Bankers  
 Henry Hauck  
 Crawford County Poor Farm  
 Stony Ridge Farm  
 Perry Miller  
 Penn. Training School  
 Pennhurst Farms  
 George Greer  
 E. S. Perry  
 Geo. Tyler  
 Thos. G. Ashton  
 Miss Anne Vanclain  
 W. W. Splane, Oil Producer  
 John Rynd, Oil Producer  
 White Horse Farms  
 H. A. Beal, Jr.  
 H. L. Detwiler  
 City of Philadelphia  
 Friends Hospital  
 Morris E. Leads  
 D. W. Dietrick, Flour  
 W. A. Myler, Sec'y & Treas. Standard Sanitary Mfg. Co.  
 Allegheny County  
 W. P. Craig  
 Dr. B. M. Dickinson  
 John A. Bell  
 Patrick Joyce  
 M. T. Phillips, Physician  
 T. P. Fitzsimmons  
 Richard C. Carlsen  
 L. S. Erway  
 Abner S. Deysher  
 Fred Neahmand  
 Jos. Heacock Co.  
 Mingo Stock Farm  
 Dr. F. W. Ketner  
 Thos. W. Dawson  
 International Correspondence School  
 Geo. Stevenson, Mining Engineer,—Hornless Holsteins  
 Thos. E. Jones, International Correspondence Schools

## PARTIAL LIST OF USERS—Continued

## PENNSYLVANIA—Continued

Seeleyville G. Smith & Bro.  
Sharon McDowell Farm  
J. S. Hoffman  
Slippery Rock S. J. Rhodes  
Smethport McLean County Home  
E. B. McKean  
Holmes & Gilfillan  
Spartansburg E. L. Henton  
Spring City Robert Cook  
Spring House Jesse Williamson  
Somerset H. W. Walker  
South Langhorne Swope Bros.  
South Monrose Percy Valentine, Ayrshires  
Sunbury W. H. Drueckemiller  
Titusville J. W. Stephens  
Ulysses F. A. Crowell  
Warren L. S. Clough  
D. W. Beaty  
C. F. Briedenbaker  
John M. Siegfried, Holsteins  
Horton-Crary Co  
Dr. C. J. Frantz  
Wattsburgh Will Gilmore  
Fred Tanner  
West Chester M. B. Worth  
Herman Hoops  
P. M. Sharples, Sharples Sep-  
arator Co.  
G. L. Jones  
Dr. J. K. Mitchell  
James McCommant  
M. L. Jones  
Wilkes-Barre Walter M. Cruttendon  
Wilksburg Ben Hormel  
Williamsport W. W. Jackson, United Farms  
Corporation  
J. Roman Way  
Windber M. E. McNeal  
E. M. Hayes  
Worcester Frank Landis  
Wynnewood Miss Mary K. Gibson  
Yardley V. J. Humbrecht  
York H. N. Forrey  
C. E. Etnier

## RHODE ISLAND—

East Greenwich C. J. Davol  
Exeter Russell Grinnell—Locust Val-  
ley Farm  
Howard State Prison Farm  
Narragansett Pier W. A. Nye—Hotel Imperial  
Providence F. S. Peck  
Kent Brothers  
Saylesville Butterfly Farm  
Touisset N. L. R. Gardner  
Warren E. W. Mason  
Warwick Nelson W. Aldrich. Lawyer,  
U. S. Senator

## SOUTH CAROLINA —

Camden J. B. Zemp  
J. H. Shanklin  
Clemson Clemson College  
Denmark Mayfield Farms  
Dillon Dr. J. H. David  
Dovesville J. L. McIntosh  
Florence State Reform School  
Gadsden Ernest H. Kanmer  
Greenville Clarence E. Smith  
Hartsville J. K. & G. Gardner  
Kinards R. G. Smith  
Orangeburg R. S. Wilkinson, State Colored  
College  
Ridge Springs H. D. Jordan, Asbell-Jordan  
Co.  
Sumter Dr. Archie China

## SOUTH DAKOTA—

Beresford Henry Muelenkort  
Booge Ole G. Eitreim  
Brookings M. Mahr

## SOUTH DAKOTA—Continued

Brookings State College  
Bruce Packham & Gill  
Canton Ole Rodway  
U. S. Indian Agency  
Centerville Hugh Langen  
W. R. Ellis  
W. A. Ellis  
Hugh Langen  
Crow Creek Crow Creek Indian Agency  
Flandreau Indian School  
Hudson P. H. Austin  
H. E. Groth  
P. H. Austin  
Madison George R. Farmer, Lawyer  
Sioux Falls State School for Deaf  
State Penitentiary  
Minnehaha County Farm  
State Hospital  
Yankton

## TENNESSEE—

Columbia Patton, Whitaker & Son.  
Lytle Creek Stock Farm  
Ducktown Copper and Iron  
Co.  
Nashville W. H. Williams  
Philadelphia A. B. Cannon, Jr.

## TEXAS—

Carlsbad Texas State Tuberculosis San-  
itarium  
College Station A. & M. College  
Dallas Metzger Bros.  
El Paso W. L. Tooley  
S. T. Turner  
Sam B. Gillette  
Falfurrias Ed. C. Lasater  
Houston E. F. Dupree  
San Antonio St. Louis College, Bros.  
Mary  
Sequin J. W. Campbell  
Thurber Texas & Pacific Coal Co.

## UTAH—

Provo State Mental Hospital  
Salt Lake City Utah State Penitentiary

## VERMONT—

Barre E. B. House  
Benson W. S. Bush—Mountain View  
Stock Farm  
Berkshire E. M. Perley  
Brattleboro Scott Farm  
Burlington C. L. Woodbury  
University of Vermont  
Fair Haven H. Stannard  
Hardwick T. G. Bronson  
Middlebury F. E. Foote  
Newport Rondeau Bros.  
Ryegate W. J. Brown  
Shelburne C. D. Ordway  
St. Albans C. S. Jennison  
Wilmington Martin A. Brown  
Windsor John Gould

## VIRGINIA—

Alexandria J. B. Chambers  
Black Walnut Owen Bros.  
Hot Springs Mrs. Jennie W. Wilke  
Lassiter State Farm  
Virginia State Prison  
Oak Ridge Thos. F. Ryan  
Petersburg Hatcher Seward  
Pulaski Eucena Vista Farms  
Randolph Cheney Bros.  
Richmond W. L. Brittle  
Spencer State Hospital  
Waynesboro Driver Bros.

## WASHINGTON—

Olympia Gen. Hazard Stevens



PARTIAL LIST OF USERS—Continued

WASHINGTON—Continued

Seattle Augustin & Kyer  
Carnation Stock Farms  
Pacific Coast Condensed Milk  
Co. (Carnation Milk)  
Sedro Woolley Northern Hospital for Insane  
Sumner Pierce County Farm

WEST VIRGINIA—

Fairmont Fairmont Farms  
Huntington Orphans Home  
McMachen Dr. P. D. Barlow  
Morgantown University of West Virginia  
Terra Alta State Tuberculosis Sanitarium  
Wheeling Hill Top Farm  
E. W. Oglebay

WISCONSIN—

Amery Jas. Flanigan  
Arcadia John C. Gaveny  
Arnott S. Earl Carley  
Ashland Theo. Werder  
Ashland Jct. State Experimental Farm  
Almena Henry Thorbeck  
Antigo Morse & Tradewell Land Co  
Albert Stengle  
Aug. Biersdorf  
Barron F. J. Krahenbuhl  
W. H. Sullivan  
Ferdinand Hellman  
E. S. Campbell  
Barron County Poor Farm  
Bangor Alois Fuchs  
Bayfield S. L. Boutin Fish Co.  
H. J. Wachsmuth. Lumber  
Manufacturer  
Biramwood John Zimmermann  
Black River Falls J. N. McNab, Ayrshires  
Blanchardville Frank Darrah  
Bruce L. E. Larson  
Burlington Burlington Cond. Milk Co  
Cameron J. N. Hickok  
Chippewa Falls State Hospital  
Corliss Saint Catherine Convent  
Cumberland Peter Olson  
Wm. Statton  
Delavan E. J. Tilden. Libby, McNeil  
& Libby  
Dresser Jct. John K. Gilbertson  
Godfrey Nelson  
Eau Claire Eau Claire County Asylum  
W. K. Coffin. Pres. Eau Claire  
National Bank  
Elkhorn John Harris  
Elm Grove Sisters of Notre Dame  
Fifield Edgar L. Remer  
Fond du Lac F. H. Boyle  
Fort Atkinson W. D. Hoard. (Ex-Governor)  
Galesville A. W. Fivesome  
Gerald Arnold  
Grand Rapids Clark & Jackson Agricultural  
School  
Halder John Maguire  
Hillsboro Landsinger Bros.  
Iola J. A. Rosholt  
Jefferson St. Coletta Institute  
Junction City Pete Hartjys  
Kenosha C. C. Allen. Black Cat Hosiery  
Keshena Keshena Indian Agency

WISCONSIN—Continued

La Crosse H. C. Oertel. Dairyman  
Dr. Christianson  
La Pointe J. E. Bissell  
Chas. L. Gilbert  
J. E. Bissell  
Marshfield Wood County Insane Asylum  
C. E. Blodgett  
Herman Schroeder  
Marathon Joseph Sticher  
C. O. Bauman  
Medford Albert Nelson  
Merrill C. P. Craft  
Henry Haas  
Albert Wendt  
State Hospital  
John Cramer  
Staufferacher Bros.  
Geo. Ahlis  
A. Paronto  
O. Bache-Wiig  
Milwaukee Fred Pabst. Brewer  
Gustav Pabst. Brewer  
E. L. Philipp Gov. of Wisc.  
L. E. Gordon, Jr.  
J. C. McDonald  
Forest County Asylum  
Henry McNutt. Breeder and  
Shipper of Holsteins  
Plover Frank Lila  
F. S. Holladay  
Frank Haasl  
Park Falls G. D. Redel. Banker  
Phillips Dr. B. C. Meacher  
Portage Racine County Hospital  
Racine Horlick's Malted Milk Co.  
F. C. Lang  
Rice Lake W. A. MacLaughlin  
Rhinelander Sisters of St. Francis  
St. Francis H. F. Taylor  
St. Croix Falls A. A. Turk. Attorney  
Sarona Hugh E. Rogers  
Stoddard Judge Luse. Attorney  
Superior Tomah Indian School  
Tomah Fred Perrault. Hotel  
Turtle Lake Dane County Hospital  
Verona Industrial School for Boys  
Waukesha Waukesha County Insane  
Asylum  
S. A. Baird & Son  
Dr. David Roberts  
Browne & McMillan  
Fruit Bros.  
J. L. Williams  
R. W. Rowlands  
R. G. Morey  
Waupun State Penitentiary  
Wauwatosa Hospital for Chronic Insane  
Milwaukee County Hospital  
Wm. Geuzmann  
Wausau Jct. Dairy  
A. Swanson, Prop.  
West Salem La Crosse Co. Insane Asylum  
J. D. McDonald  
Wittenberg C. E. Peterson

WYOMING—

Cheyenne State Farm  
Wheatland W. A. Baker  
Worland State Reformatory



INDEX

Abortion . . . . .	137	Regulating Tank . . . . .	183
Adjuster . . . . .	295	Pressure System, Type 7 . . . . .	184, 185
Air, Entrance for Fresh . . . . .	81	Pressure System, Type 6 . . . . .	186
How Much Needed by Cow . . . . .	61	Wash Tank . . . . .	187, 271
Alley Chains . . . . .	314	Strainer . . . . .	183
Alley Gate . . . . .	314	Dumps Either Way, Carrier . . . . .	229
Alignment Device . . . . .	119	Dust Proof Fittings . . . . .	115
Anchors, for Pen . . . . .	189	Enamel Finish . . . . .	129
For Stall Partitions . . . . .	117	Entrance for Fresh Air . . . . .	81
For Steel Stall . . . . .	123	Erection of Stalls . . . . .	123, 161
Anchor Stocks . . . . .	127	Farrowing Rail, Hog Pen . . . . .	217, 219
Appearance of Barn . . . . .	17, 285	Fat Stock Feeding Panel . . . . .	211
Assembled before Shipment . . . . .	127	Feed Box . . . . .	301
Bail Carrier . . . . .	229	Feeding Basket . . . . .	316
Barn, Building A . . . . .	11	Feed Carrier, Specifications . . . . .	243
Plank Frame . . . . .	25	Feed Manger, Tilting, for Cow Pen . . . . .	201, 203
Appearance of . . . . .	17	Feeding Rack for Sheep . . . . .	315
Fundamentals of . . . . .	13	Feeding Rack for Calves . . . . .	315
Site of . . . . .	15	Feed Truck, Specifications . . . . .	269
Size of . . . . .	17	Finish of Equipment . . . . .	129
Walls of . . . . .	19	Finish of Ventilators . . . . .	287, 291
Barn Plan Service . . . . .	83	Fittings, Sanitary . . . . .	115
Barn Scrapers . . . . .	308	Floors, Stable . . . . .	21
Barn, Ventilating the . . . . .	67	Material for . . . . .	23
Barns, Plank Frame . . . . .	25	Thickness of . . . . .	23
Beef Feeding Panel . . . . .	211	Flue, Essentials of Ventilating . . . . .	79
Big Boy Hoist . . . . .	231	Construction of . . . . .	81
Carrier Specifications . . . . .	241	Foreword . . . . .	5
Big Knees . . . . .	135	Frame, Plank . . . . .	25
Brake, Carrier . . . . .	231	Frame of Stall . . . . .	113
Building a Dairy Barn . . . . .	11	Fresh Air, Entrance for . . . . .	81
Bull Pen . . . . .	193, 197	Front Panel, Swinging, for Hog Pen . . . . .	217, 219
Bull Pen Gate Lock . . . . .	195	Gate Lock for Bull Pen . . . . .	195
Bull Staff . . . . .	311	Hinge . . . . .	191
Bull Stall . . . . .	159	Grand Prize . . . . .	89
Calf Feeding Rack . . . . .	315	Guarantee . . . . .	318
Calf Pail Holder . . . . .	310	Guards for Calf Pen . . . . .	209
Calf Pens . . . . .	205	Gudgeon . . . . .	229
Specifications . . . . .	209	Gutter . . . . .	103
Manger . . . . .	209	Hanger, Double Chain . . . . .	109
Stanchions . . . . .	209	Hangers, for Carrier Track . . . . .	238
Guards . . . . .	209	Harness Hooks . . . . .	301
Hay Feeding Rack . . . . .	210	Hay Racks . . . . .	300
Carriers . . . . .	221	Health of Cows . . . . .	95
Carrier, Big Boy, Specifications . . . . .	241	High Lift . . . . .	235
Chore Boy, Specifications . . . . .	259	Hinge . . . . .	111
Combination, Specifications . . . . .	267	Hog Pen . . . . .	213
Feed, Specifications . . . . .	243	Farrowing Rail . . . . .	217, 219
Milk Can, Specifications . . . . .	245	Specifications . . . . .	219
Swill, Specifications . . . . .	247	Swinging Panel . . . . .	217, 219
Carrier Support, Outside . . . . .	257	Tilting Trough . . . . .	217, 219
Alongside Barn . . . . .	257	Hog Trough . . . . .	307
Chain Guides . . . . .	233	Hoist Carrier . . . . .	231
Channels . . . . .	301	Horse Stable Equipment . . . . .	297
Chore Boy Carrier Specifications . . . . .	259	Horse Stall Guards . . . . .	299
Parts . . . . .	260	Horse Stall Post . . . . .	301
Clutch, Carrier . . . . .	231	Horse Box Stall . . . . .	303
Columns, Supporting . . . . .	19, 305	I-Beam Track . . . . .	235
Combination Carrier . . . . .	263	Intakes, Ventilation . . . . .	71
Parts . . . . .	261	James System of Ventilation . . . . .	69
Specifications . . . . .	267	Barn Plan Service . . . . .	83
Combination Switches . . . . .	262	Keeper, Prevents Carrier Jumping Track . . . . .	233
Complete Manger . . . . .	135	Lifting Chain . . . . .	235
Concrete, Material for Floors . . . . .	23	Lifting Springs for Manger . . . . .	141
Mixing . . . . .	23	Light . . . . .	31
Proportions of . . . . .	23	Linings, Wood . . . . .	109
Construction of Flues . . . . .	81	Lock for Bull Pen Gate . . . . .	195
Of Manger . . . . .	137	Lock Open . . . . .	105
Cork Brick . . . . .	313	Lock, Stanchion . . . . .	113
Corner Feed Box . . . . .	301	Manger, Complete . . . . .	135
Cow Pen . . . . .	199	Construction . . . . .	137
Specifications . . . . .	203	Division . . . . .	141
Tilting Manger . . . . .	201, 203	Manger Division Holder . . . . .	142
Stanchion . . . . .	203	Lifting Springs . . . . .	141
Crane, Swinging . . . . .	251, 253	For Bull Pen . . . . .	197
Divisions for Mangers . . . . .	141	For Calf Pen . . . . .	209
Double Chain Hanger . . . . .	109	For Cow Pen . . . . .	203
Drain . . . . .	316	Manger Cleaners . . . . .	309
Drinking Cups . . . . .	171, 179	Material for Concrete . . . . .	23
For Pens . . . . .	191	Milk Can Carrier Specifications . . . . .	245
Gravity System, Type 4 . . . . .	181	Milk Can Truck . . . . .	271
Gravity System, Type 5 . . . . .	181	Milk Stool . . . . .	306
Location of . . . . .	179	Milking Machine Fittings . . . . .	316

## INDEX—Continued

Mixing Concrete.....	23	14C, 14C-TA15.....	155
Name Plate.....	312	14A.....	157
Openings to the Ventilators.....	81	Bull Stall.....	159
Outside Support for Carrier.....	257	Stalls.....	143
Pail Holder.....	310	Special Features of.....	103
Paint.....	312	Stanchions.....	143
Panama Pacific Exposition Grand Prize.....	89	Stanchion for Bull Pen.....	197
Panels and Posts, Bull Pen.....	191	For Calf Pen.....	209
Partitions, Stall.....	115	For Cow Pen.....	203
Partitions, Anchors.....	117	Stanchion, Steel, No. J14.....	163
Pens.....	189	Steel, No. T15, TA15, TC15.....	165
Easy to Set Up.....	129, 189	Steel, X18 and XA18.....	167
Tubular Anchors for.....	189	Wood, W18 and WA18.....	169
Water Cups for.....	191	Stocks of Anchors.....	127
Weight of Materials.....	191	Strainer.....	183
Pen for Bull.....	193, 197	Support for Carriers, Outside.....	257
Gate Hinge.....	191	Alongside Barn.....	257
Gate Lock.....	195	Supporting Posts or Columns.....	19, 305
Manger.....	197	Sure Stop.....	103
Panels and Posts.....	197	Swill Carrier, Specifications.....	247
Specifications.....	197	Swinging Crane.....	251, 253
Stanchion.....	197	Swinging Sure Stop.....	103
Pen for Calves.....	205, 209	Switches, Carrier.....	239
Pen for Cows.....	199, 203	Tilting Cow Pen Manger.....	201, 203
Pens for Hogs.....	213	Tilting Trough for Hog Pen.....	217, 219
Plan Service.....	83	Track for Carrier (I-Beam).....	235
Plank Frame Barns.....	25	Track Hangers.....	238
Posts, Supporting.....	19, 305	Track Section, Removable.....	235
Proportions of Concrete.....	23	Tracker Wheels.....	233
Registers.....	295	Trucks for Carrier.....	233
Regulating Tank.....	183	Trunnion.....	229
Removable Track Section.....	235	Tubs, Carrier.....	229
Removable Flexible Track Section.....	253	Tubular Anchors for Pens.....	189
Sanitary Fittings.....	115	Ventilating the Barn.....	67
Scale.....	313	Ventilating Flues, Essentials of.....	79
Scrapers.....	308	Ventilation, James System of.....	69
Self-Cleaning Manger.....	137	Degree Necessary.....	75
Service, Barn Planning.....	83	Intakes.....	71
Setting up Pens.....	189	Sizes of Flues.....	77
Setting up Stalls.....	123	Ventilation.....	53
Shaft, Carrier.....	235	Ventilator, Openings to the.....	81
Sheep Feeding Rack.....	315	Ventilators, James.....	273
Shipped Assembled.....	127	Finish.....	287, 291
Silos and Silage.....	15	Revolving Hood.....	279
Site (for Barn).....	17	Size to Buy.....	289
Size (of barn).....	17	Solid Hood.....	289
of Ventilating Flues.....	77	With Revolving Hood, Specifications.....	287
Space per Animal.....	79	With Solid Hood, Specifications.....	291
Specifications.....	147	Walls (of Barn).....	19
Springs, Manger Lifting.....	141	Watering Buckets.....	171, 179
Stall Anchors.....	123	Wash Tank for Drinking Cups.....	187, 271
Stall Frame.....	113	Watering Cups for Pens.....	191
Stall Partitions.....	115	Window Ventilators.....	295
Stall Partition Anchors.....	117	Windows, Double Glazed.....	295
Stall Specifications, 14B, 14B-TA, 14B-X18.....	149	Wood Linings.....	109
18F.....	151	Young Stock Panel.....	211
18E-XA18.....	153		

## INDEX OF ILLUSTRATIONS

Adams, E. B. & Son, Exterior.....	76	Belden, Wm. P.....	86
Adjuster for Outtakes.....	294	Big Boy Carrier.....	218, 228, 240
Aitken Bros., Exterior.....	86	Blake, Charles.....	84
Alley Gate.....	314	Bolts, Extension.....	236, 238, 301
Alignment.....	118, 121	Borden's Condensed Milk Co., Exterior.....	10
F. P. Lansing, Interior.....	120	Bowditch, N. I., Interior.....	121
Amos, C. L., Exterior.....	22	Box Stalls, Horse.....	302
Anchor Rod and Turnbuckle.....	260	Bracket, Angle, Rod Track.....	260
Anchors, Partition.....	116, 122	Bradley, J. F., Exterior.....	78
Pen.....	192	Brake, Carrier.....	230
Stall Post.....	122	Briggs, Glen L., Interior.....	76
Stanchion.....	122	Broadlawn Farms, Interior.....	32, 214
Angle Bracket, Rod Track.....	260	Bull Manger.....	190, 196
Appearance of Ventilators.....	284	Bull Pen.....	196
Arch Support, Outside.....	254, 255, 256, 257, 272	Bull Pen Gate.....	194
Babson, F. K., Exterior.....	70	Bull Pen Hinge.....	194
Banner, Grand Prize.....	88	Bull Pen Lock.....	194
Barron, C. W., Interior.....	200	Bull Staff.....	310
Barn Plan Department.....	82	Bull Stanchion.....	190
Barn Scrapers.....	30, 308, 309	Butterfly Farm, Interior.....	121
Base of Ventilators.....	285	Cabana, Oliver, Jr., Exterior.....	80
Beach, D. M., Exterior.....	22	Calf Pail Holder.....	310

## INDEX OF ILLUSTRATIONS—Continued

Calf Pen . . . . .	206, 207, 208	Feed Box, Corner . . . . .	301
Calf Pen Guards, "Anti-Sucking" . . . . .	206, 207, 208	Feeding Basket . . . . .	316
Calf Pen Hay Rack . . . . .	210	Feed Car . . . . .	242
Can Carrier, Milk . . . . .	226	Feed Truck . . . . .	226, 268
Car, Feed . . . . .	242	Field, D. W. . . . .	70, 74
Carrier and Parts . . . . .	228	Fink, William, Exterior . . . . .	24
Big Boy . . . . .	228	Fittings, Stall . . . . .	114
Brake . . . . .	230	Flick, A. R., Exterior . . . . .	80
Clutch . . . . .	230	Flooring, Cork Brick . . . . .	313
Hoist . . . . .	230	Frankberg, G. W., Exterior . . . . .	24
Tracker Wheels . . . . .	232	Friend's Hospital, Exterior and Interior . . . . .	16, 200
Shaft, Track, etc . . . . .	234	Gate, Bull Pen . . . . .	194
Hangers . . . . .	236	Getzelman, T. E., Exterior . . . . .	32
Switches . . . . .	237	Goodrich, C. P. . . . .	317
Carrier, Big Boy . . . . .	220, 228, 240	Grahl Bros., Exterior . . . . .	224
Chore Boy . . . . .	260	Grand Prize Banner . . . . .	88
Combination . . . . .	266	Greek, Mrs. Mary, Interior of Barn . . . . .	214
Milk Can . . . . .	226, 244	Grundy, Jos. R., Erecting Equipment . . . . .	124
Swill . . . . .	214	Guards, Calf Pen . . . . .	206, 207, 208
Central Creamery Co., Exterior . . . . .	18	Guards, Horse Stall . . . . .	301
Chain Hanger, Double . . . . .	110	Hanger, Double Chain . . . . .	101
Chain, Shaft and Lifting . . . . .	234	Hangers . . . . .	236, 238
Chapman, H. H., Exterior . . . . .	10	Hangers to Pass Girders . . . . .	238
Chase, H. E., Exterior . . . . .	80	Harness Hooks . . . . .	301
Chore Boy Carrier . . . . .	258	Hay Racks . . . . .	210, 300
Carrier Parts . . . . .	260	Hellums, H. D., Exterior . . . . .	274
Clamp Rod Track . . . . .	260	Hill Top Certified Dairy Farm, Manure Pit . . . . .	224
Cleaner, Manger . . . . .	309	Hinge, Stanchion . . . . .	110
Cleveland, City of, Exterior . . . . .	74	Hinge for Bull Pen . . . . .	194
Clough, L. S., Exterior . . . . .	70	Hired Men, Why They Quit . . . . .	222
Clutch, Carrier . . . . .	230	Hog Barn Cross Section . . . . .	212
Columns . . . . .	20, 304, 305, 306	Hog Barn Interiors . . . . .	214
Combination Carrier Illustrations . . . . .	264, 265	Hog Pens . . . . .	216, 218
Hoist . . . . .	261	Hog Trough . . . . .	307
Parts . . . . .	261	Hoist, Big Boy . . . . .	230
Track Transfer . . . . .	261	Hoist Combination Carrier . . . . .	261
Tracker Wheels . . . . .	261	Holton, Frank . . . . .	84
Combination Carrier . . . . .	266, 272	Home Plant . . . . .	8, 9
Combination Switch . . . . .	262	Hood, H. P. & Sons, Interior . . . . .	121
Complete Mangers . . . . .	136	Hood Revolving, of Ventilator . . . . .	282, 286
Concrete Yard . . . . .	68	Hood, Solid, of Ventilator . . . . .	288, 290, 292
Construction of Ventilators (Diagrams) . . . . .	276, 278, 283, 289	Horse Stall Guards . . . . .	299
Revolving Hood . . . . .	282, 286	Horse Stall Post . . . . .	301
Control Clutch and Brake, Carrier . . . . .	230	Horse Stall, Wood . . . . .	296, 298
Cork Brick Flooring . . . . .	313	Horse, Box Stall . . . . .	302
Corner Feed Box . . . . .	301	Howe, E. D., Exterior . . . . .	16
Cow Cleanliness . . . . .	92	Howe, John, Exterior . . . . .	24
Cow Comfort . . . . .	90	I-Beam Track . . . . .	234
Cow Pen . . . . .	202	Instructions for Erecting Stalls . . . . .	161
Crane on Mast . . . . .	250	Intakes, Ventilator . . . . .	66
Crane, Swinging . . . . .	248, 249, 250, 252	James, W. D. . . . .	317
Cross Section, Hog Barn . . . . .	212	Jin Pole Support for Crane . . . . .	250
Culver, H. E., Exterior . . . . .	68	Kramer, John, Exterior . . . . .	30
Culver, H. E., Interior . . . . .	68	Lansing, F. P., Interior . . . . .	120
Cups, Drinking . . . . .	172, 174, 176, 188	Lawson, Victor . . . . .	176
Cup, Wash Tank, Drinking . . . . .	187, 270	Leitsch, Wm. C. . . . .	86, 176
Curtis, H. H. . . . .	317	Lewis, Harry . . . . .	84
Curve or Switch, Rod Track . . . . .	260	Lifting Chain . . . . .	234
Davis Bros. . . . .	84	Lock, Bull Pen . . . . .	194
Day, D. H., Exterior . . . . .	72	Lock, Door Knob . . . . .	112
Dean, Albert, Exterior . . . . .	226	Lone Tree Farm . . . . .	204, 206
Delchester Farms, Exterior . . . . .	72	Lowden, Col. F. O., Interior . . . . .	220
Dickinson, H. E., Exterior . . . . .	86	Mackenzie, Alex, Interior . . . . .	18
Dietrick, D. W., Exterior . . . . .	12	Manger, Bull . . . . .	190, 196
Directions for Erecting Stalls . . . . .	124, 132	Manger, Cleaner . . . . .	309
Divisions, Manger . . . . .	138, 140	Mangers, Complete . . . . .	136
Dormer Windows . . . . .	16	Manger Divisions . . . . .	138, 140
Double Chain Hanger . . . . .	110	Division Holder . . . . .	142
Drain . . . . .	316	for Calf Pens . . . . .	206
Drinking Cups . . . . .	172, 174, 176, 188	Operation of . . . . .	134, 136
Type 4 . . . . .	180, 181	Pattern . . . . .	124
Type 5 . . . . .	180	Troughs, Different Styles of . . . . .	139
Type 7 . . . . .	184, 185	Marshall, H. T., Interior . . . . .	30
Type 6 . . . . .	186	Metcalf, F. H., Exterior . . . . .	80
Drinking Cup Wash Tank . . . . .	187, 270	Milanhurst Stock Farm, Exterior . . . . .	222
Dunn Co., Asylum . . . . .	176, 272	Milk Can Carrier . . . . .	226, 244
Dupee, Walter H., Exterior . . . . .	74	Milk Can Truck . . . . .	271
Elmira Plant . . . . .	6	Milk Stool . . . . .	307
End Stop, Rod Track . . . . .	260	Name Plates . . . . .	312
Erecting Equipment . . . . .	124-132	North Florida Dairy Farms, Exterior . . . . .	18
Cross Section of Stall and Floor . . . . .	161	North Florida Dairy Farms, Erecting Equipment . . . . .	128
Experimental Barn, Exterior . . . . .	280, 281	Notre Dame University, Exterior . . . . .	80
Fairfax Creamery, Exterior . . . . .	274	Old Way Carrier (Wheelbarrow) . . . . .	222, 224
Fat Stock Feeding Panel . . . . .	211	Outside Arch Support . . . . .	254, 255, 256, 272
		Outside Wood Support . . . . .	253, 257

## INDEX OF ILLUSTRATIONS—Continued

Outtakes, Ventilator . . . . .	66, 274	Stevens, S. P., Exterior . . . . .	24
Pabst, Fred, Calf Barn . . . . .	206	Stillwell, W. E., Interior and Exterior . . . . .	70, 74
Packham & Gill, Exterior . . . . .	18	Stimson, C. D., Exterior . . . . .	32
Pail Holder . . . . .	210	Stock Panel, Young . . . . .	211
Paint . . . . .	312	Stoltz, William F., Interior . . . . .	30
Panel, Young Stock . . . . .	211	Strainer . . . . .	183
Partition Anchors . . . . .	116	Suffolk County Poor Farm, Exterior . . . . .	78
Partitions . . . . .	116	Sunshine on the Gutter . . . . .	14
Patterson, M., Exterior . . . . .	76, 222	Supply Tank . . . . .	182, 188
Pelouse, Wm. N., Exterior . . . . .	250	Support, Arch, Outside . . . . .	254, 255, 256, 272
Pen Anchor, Tubular . . . . .	192	Support, Jin Pole . . . . .	250
Pen, Bull . . . . .	196	Support, Outside, Wood . . . . .	255, 257
Pen, Calf . . . . .	206, 207, 208	Sure Stop in Use . . . . .	104, 106, 107
Pen, Cow . . . . .	202	Suspender, Rod Track . . . . .	260
Pen Gate, Bull . . . . .	194	Swill Carrier . . . . .	214, 246, 247
Pen Gate Lock, Bull . . . . .	194	Swinging Crane . . . . .	248, 249, 250, 252
Pen Gate Hinge, Bull . . . . .	194	Switch, Rod Track . . . . .	260
Perry, Enoch, Exterior and Interior . . . . .	14, 16, 214	Switches . . . . .	239
Plant . . . . .	8, 9	Syracuse University, Exterior . . . . .	12, 274
Plank Framing . . . . .	26, 24	Tenny, D. D. . . . .	255
Plant Farms, Exterior . . . . .	86	Tension Bolt, Rod Track . . . . .	260
Quinn, Frank J., Exterior . . . . .	10	Thompson, Carl, Exterior . . . . .	76
Registers . . . . .	294	Thomson, F. H. & Son, Interior and Exterior . . . . .	12, 72
Regulating Tank . . . . .	183	Tilting Feed Manger for Cow Pens . . . . .	202
Reiss, Peter, Interior . . . . .	198, 226	Track, I-Beam . . . . .	234
Removable Section . . . . .	234	Track and Splice . . . . .	260
Returning Device, Rod Track . . . . .	260	Track Strut . . . . .	261
Rod Track, Tension Bolt, etc. . . . .	260	Track Transfer, Combination Carrier . . . . .	261
Rohda, A., Exterior . . . . .	68	Tracker Wheels . . . . .	232
Rundell, Lloyd, Interior . . . . .	30	Tracker Wheels, Combination Carrier . . . . .	261
Safety Device . . . . .	260	Traverse City, Barn of, Interior . . . . .	22
Safety Switches . . . . .	239	Troughs, Manger, Different Styles of . . . . .	139
Sayre, E. N., Interior . . . . .	7	Truck, Milk Can . . . . .	271
Scales, Dairy . . . . .	313	Tuberculosis Sanitarium, Interior and Exterior . . . . .	66, 78
Schmidt, Carl E., Interior . . . . .	10	Tubular Pen Anchor . . . . .	192
Scrapers, Barn . . . . .	30, 308, 309	Turnbuckle and Anchor Rod . . . . .	260
Sears, Irving, Interior . . . . .	121	United States Indian School, Exterior . . . . .	32
Section, Removable . . . . .	234	University of Wisconsin, Exterior and Interior . . . . .	16, 174
Shaft and Lifting Chain . . . . .	234	Vanes for Ventilators . . . . .	293
Sheep and Calf Feeding Rack . . . . .	315	Van Winkle, G. H., Interior . . . . .	200
Smaltz, E. E., Exterior . . . . .	12	Ventilators, Appearance of . . . . .	284
Smith, W. T., Interior . . . . .	18	Base of . . . . .	285
Sorlie, A. J., Exterior . . . . .	72	Construction Diagrams . . . . .	276, 278, 283, 289
Splice and Track . . . . .	234	Revolving Hood . . . . .	282, 286
Stall and Its Parts . . . . .	102	Solid Hood . . . . .	30, 288, 290, 292
Stall, 14A . . . . .	156	Ventilator Vanes . . . . .	293
14B . . . . .	144, 146, 148	Ventilator Diagrams . . . . .	66
14C . . . . .	154	Outtakes . . . . .	66
18F . . . . .	150	Intakes . . . . .	66
18E . . . . .	152	Walker, J. W. G., Exterior . . . . .	14
Stall for Bull . . . . .	158	Waukesha County Asylum, Exterior . . . . .	22
Stall Fittings . . . . .	114	Waukesha County Asylum, Interior . . . . .	304
Stall Post Anchors . . . . .	122	Waupun State Prison, Interior and Exterior . . . . .	20, 70
Stalls, Horse . . . . .	296, 298, 302	Wheelbarrow, Old Carrier Way . . . . .	222, 224
Stall, Wood . . . . .	160	Wheels, Tracker . . . . .	232
Stanchion Anchors . . . . .	122	White Horse Farm, Interior . . . . .	200
Stanchion, Bull . . . . .	190	Whiteleather, D. V., Exterior . . . . .	24
Stanchion, 14J . . . . .	162	Window, Double Glazed . . . . .	294
TA-15 . . . . .	164	Window Ventilator . . . . .	294
T-15 . . . . .	164	Wood Horse Stalls . . . . .	296, 298
X-18 . . . . .	166	Wood Support Alongside Barn . . . . .	255, 257
XA-18 . . . . .	166	Wood Support, Outside Track . . . . .	255, 257
WA-18 . . . . .	168	Young Stock Panel . . . . .	211
W-18 . . . . .	168	Young Stock Barn . . . . .	204, 206
Stanchion Panel, Young Stock . . . . .	211	Ziegler, D., Exterior . . . . .	14, 84
State Tuberculosis Sanitarium, Exterior . . . . .	66, 78		

## INDEX OF BLUE PRINTS

Arrangement of Floor, Cross Section . . . . .	46-49	Purline Plate, Detail . . . . .	38
Cross Section of Floor . . . . .	46-49	Round Barn Floor Plan . . . . .	64
Cross Section Perspective of Barn . . . . .	33	Side Elevation . . . . .	34
Cross Section, Typical . . . . .	41-45	Sliding Door, Hay Chute . . . . .	39
Details . . . . .	38, 39, 40	Tie Plate, Detail . . . . .	38
Elevations, Side and End (Blue Print) . . . . .	34	Truss, Typical . . . . .	35
Floor Plans . . . . .	50-52	Typical Truss . . . . .	35
Framing, End Elevation . . . . .	37	Ventilating System, Connection to Ventilator . . . . .	56
Framing, Side Elevation . . . . .	36	Ventilating System, Cross Section . . . . .	54-55
Framing, Window . . . . .	40	Ventilating System, Floor Plan . . . . .	58, 59
Hay Chute Sliding Door . . . . .	39	Ventilating System, Intakes . . . . .	62
Hog Barn Floor Plan . . . . .	64	Ventilating System, Outtakes . . . . .	60
Perspective Cross Section of Barn . . . . .	33	Window Detail . . . . .	40

















