



SF  
757  
S64x  
1911



FLOWER-SPRECHER

*Library*

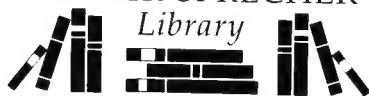





*This book was digitized by Microsoft Corporation in cooperation with Cornell University Libraries, 2007. You may use and print this copy in limited quantity for your personal purposes, but may not distribute or provide access to it (or modified or partial versions of it) for revenue-generating or other commercial purposes.*









A MANUAL  
OF  
VETERINARY HYGIENE





A MANUAL  
OF  
VETERINARY HYGIENE

BY

COLONEL F. SMITH, C.M.G.

ARMY VETERINARY DEPARTMENT

FELLOW OF THE ROYAL COLLEGE OF VETERINARY SURGEONS

FELLOW OF THE INSTITUTE OF CHEMISTRY

AUTHOR OF 'A MANUAL OF VETERINARY PHYSIOLOGY,' 'A MANUAL OF  
SADDLES AND SORE BACKS,' ETC.

*FIFTH EDITION—REWRITTEN*



NEW YORK  
WILLIAM R. JENKINS CO.  
PUBLISHERS

851-853 SIXTH AVENUE  
(Cor. 48th Street)

1912

[All rights reserved]





## P R E F A C E

No apology appears necessary for the increase in size of this Edition; it was impossible within any smaller compass to deal with a subject of the first importance. The time had arrived when the whole question required more extensive handling than was considered desirable when the first edition of this book was published; in consequence the Manual has been completely rewritten.

The extraordinary advances made in our knowledge during the last eighteen years have revolutionized our pathology, and an accurate knowledge of pathology is one of the pillars of preventive medicine.

It was impossible that a work organized on the present lines could be carried out single-handed. I have been fortunate in securing the co-operation of Dr. Arnold Theiler, Veterinary Pathologist to the Government of the Transvaal, in writing the chapter dealing with Bacteria and Immunity. I am indebted to his original investigations, and those of Mr. Lounsbury, B.Sc., Entomologist to the Government of the Cape of Good Hope, in the matter of the Tick transmission of disease. The profound influence which the work of these gentlemen has exercised over our knowledge of the infection and prevention of tropical diseases of animals cannot yet be fully estimated. As a

profession we tender them our gratitude, as an individual I beg to express my personal thanks and indebtedness.

I gratefully acknowledge the assistance received from the published papers of Mr. J. Malcolm, F.R.C.V.S., in the matter of Dairy Inspection; to Mr. Cope, C.B., F.R.C.V.S., I beg to offer my thanks for reading the summary of the law in relation to the Contagious Diseases of Animals; to Mr. W. Woods, F.R.C.V.S., of Wigan, for information relating to the life of animals in coal mines; to Professor McFadyean and Mr. Hunting, F.R.C.V.S., for reading the proofs on State Hygiene, and to both of them for their many valuable contributions to Veterinary literature on which I have freely drawn.

Mr. Stockman, Chief Veterinary Officer, Board of Agriculture, kindly contributed the section dealing with 'Meat Inspection'; Mr. H. Leeney, M.R.C.V.S., that devoted to the 'Care and Management of Dogs'; Major Butler, A.V.D., the section on the 'Production of Calf Lymph'; Major Eassie, D.S.O., A.V.D., on the 'Organization of Remount Depots in War'; Captain Olver, A.V.D., wrote the chapter on the 'Hygiene of Breeding'; Mr. Lloyd, F.R.C.V.S., of the Sanitary Department, Sheffield, was good enough to furnish me with drawings of Sanitary and Insanitary Cow Houses, a subject he has specially studied; Professor Green, D.Sc., F.R.S., kindly revised the section dealing with Poisonous Plants; Mr. Burt-Davy, F.L.S., Botanist to the Transvaal Government, favoured me with many notes on Cattle Poisons of the Transvaal; while Dr. Stewart MacDougall, Consulting Entomologist to the Highland Agricultural Society of Scotland, very kindly revised the section dealing with the Diptera.

It is impossible for me to adequately express my thanks

to all these gentlemen for their valuable co-operation in the production of this Manual.

In the preparation of this Edition, I have consulted a very scattered literature, but would particularly mention Dr. Fream's Edition of Youatt's 'Complete Grazier,' which is a store-house of information, and has afforded me many valuable references to original papers.

I am indebted to Mr. F. B. Smith, Director of Agriculture, Transvaal, for permission to utilize the excellent Library of that Department, which has given me an opportunity of consulting in the original many valuable papers in the Royal Agricultural and Highland and Agricultural Societies' publications.

The work of reading the final proofs of this book has been very kindly undertaken by Major Butler, A.V.D. Owing to my absence abroad, this has been both time-saving and of immense service, and I beg to offer him my best thanks.

I am obliged to several firms for the loan of blocks, and hereby beg to express my indebtedness to Messrs. F. and A. Dickson, Seedsmen, Chester, for the figures of 'Grasses'; Messrs. Musgrave and Co., Belfast, for nearly all the blocks illustrating 'Stable Fittings'; and the St. Pancras Ironworks Co., London, for the remainder. Messrs. Manlove, Alliott and Co., Nottingham, furnished the figure of an 'Incinerator'; The Deeming Co., Ohio, U.S.A., supplied those of Spray Pumps; The Ice and Cold Storage Publication Co. the blocks illustrating the apparatus for the sterilization and destruction of Flesh unfit for Food; Messrs. Ransomes, Sims and Jefferies, Ipswich, the figure of Plough attachments; Messrs. Rands and Jeckell, of Ipswich, the figures of Sheep Shelters; and Messrs. Crosskills, of Beverley, the block illustrating an Ambulance for

Animals. Messrs. Barford and Perkins, Peterboro', and Messrs. Richmond and Chandle, Manchester, have obligingly furnished the figures of Food-preparing Machinery. Dr. Fream has been good enough to supply all the figures illustrating the Artificial Grasses, while the Editors of the *Journal of the Royal Agricultural Society* and *Transactions of the Highland and Agricultural Society of Scotland* have lent the blocks illustrating some of the Parasitic and other Flies, the Yew Tree, and Cowsheds.

F. S.

PRETORIA, SOUTH AFRICA,  
*June, 1905.*

# CONTENTS

CHAPTER	PAGE
INTRODUCTION	xvii
I. WATER	1
II. AIR - - -	31
III. VENTILATION -	53
IV. FOOD - - - -	90
V. HABITATIONS -	273
VI. DISPOSAL OF EXCRETA	356
VII. SOILS	382
VIII. DISINFECTION	396
IX. PARASITES -	415
X. MICROBES—INFECTION—IMMUNITY	446
XI. STATE HYGIENE	466
XII. MUNICIPAL HYGIENE - - - -	647
XIII. THE CARE AND MANAGEMENT OF ANIMALS -	724
XIV. HYGIENE OF BREEDING -	876
XV. TRANSPORT OF ANIMALS BY SEA AND LAND	899
XVI. MILITARY HYGIENE	933
XVII. CLIMATE	992
XVIII. STATISTICAL INQUIRY	1000

## APPENDICES

APPENDIX I	1012
APPENDIX II	1013
APPENDIX III	1014
INDEX	1016



## LIST OF ILLUSTRATIONS

FIG.	PAGE
1. Transverse section of stable . . . . .	63
2. Boyle's system for supplying fresh and warmed air to stables . . . . .	65
3. Section of a stable heated artificially by means of Boyle's gas-bracket . . . . .	66
4. Sheringham ventilating window (Musgrave) . . . . .	68
5. Sheringham ventilating window (Musgrave) . . . . .	69
6. Direction taken by air currents with the windows open to windward . . . . .	70
7. Direction taken by air currents with windward and leeward windows open . . . . .	71
8. Double current from opposite windows . . . . .	71
9. Direction taken by air currents when opposite windows are half open . . . . .	72
10. Direction taken by air currents when all doors and windows are closed . . . . .	72
11. Simple extraction cowl (Parkes) . . . . .	73
12. Inlet cowl (Parkes) . . . . .	73
13. Boyle's air-pump extractor . . . . .	74
14. Plan of Boyle's air-pump . . . . .	74
15. Inlet shaft with angle . . . . .	75
16. Inlet shaft curved . . . . .	75
17. Divided tube (Parkes) . . . . .	76
18. McKinnell's tube (Parkes) . . . . .	76
19. Tobin's tube . . . . .	77
20. Ventilating stable pillar on the principle of a Tobin's tube . . . . .	78
21. Air-bricks . . . . .	79
22. Air-bricks . . . . .	79
23. Transverse section of stable . . . . .	82
24. Transverse section of stable . . . . .	82
25. Blackman Air-Propeller . . . . .	83
26. Smut of Oats (Fream) . . . . .	163
27. Rust and Mildew (Fream) . . . . .	164
28. Spike of Ergotized Rye (Smith) . . . . .	165
29. Ergots germinating (Smith) . . . . .	166
30. <i>Botrytis grisea</i> (Boucher) . . . . .	166
31. <i>Penicillium glaucum</i> (Boucher) . . . . .	166
32. <i>Oidium aureum</i> (Boucher) . . . . .	167
33. Ear Cockle, showing the nematoid worms (Smith) . . . . .	168

FIG.	PAGE
34. <i>Tenebrio mollitor</i> , slightly magnified (Magne and Baillet) . . . . .	168
35. <i>Ptinus fur</i> , magnified (Magne and Baillet) . . . . .	168
36. <i>Gamasus fenorum</i> , magnified (Magne and Baillet) . . . . .	169
37. Small yellow argas, magnified (Magne and Baillet) . . . . .	169
38. Small white argas, magnified (Magne and Baillet) . . . . .	169
39. The Meadow Saffron ( <i>Colchicum autumnale</i> ) . . . . .	172
40. Hemlock ( <i>Conium maculatum</i> ) . . . . .	173
41. Fool's Parsley ( <i>Aethusa cynapium</i> ) . . . . .	174
42. The Cowbane ( <i>Cicuta virosa</i> ) . . . . .	175
43. The Water Dropwort ( <i>Eranthe crocata</i> ) . . . . .	177
44. The Deadly Nightshade ( <i>Atropa Belladonna</i> ) . . . . .	178
45. The Bitter-sweet ( <i>Solanum Dulcamara</i> ) . . . . .	179
46. The Henbane ( <i>Hyoscyamus niger</i> ) . . . . .	180
47. The Aconite ( <i>Aconitum napellus</i> ) . . . . .	182
48. <i>Equisetum palustre</i> . . . . .	185
49. Darnel ( <i>Lolium temulentum</i> ) . . . . .	186
50. Yellow Tulp (Davy) . . . . .	188
51. <i>Dichapetalum cymosum</i> (Davy), two-thirds natural size . . . . .	189
52. Yew Tree ( <i>Taxus baccata</i> ) . . . . .	192
53. Meadow foxtail (Dickson) . . . . .	210
54. Sweet vernal (Dickson) . . . . .	210
55. Crested dogstail (Dickson) . . . . .	211
56. Cocksfoot (Dickson) . . . . .	211
57. Sheep's fescue (Dickson) . . . . .	213
58. Hard fescue (Dickson) . . . . .	213
59. Meadow fescue (Dickson) . . . . .	214
60. Tall fescue (Dickson) . . . . .	214
61. Italian rye grass (Dickson) . . . . .	215
62. Perennial rye grass (Dickson) . . . . .	215
63. Timothy, or catstail (Dickson) . . . . .	217
64. Smooth-stalked meadow grass (Dickson) . . . . .	217
65. Rough-stalked meadow grass (Dickson) . . . . .	218
66. Golden oat grass (Dickson) . . . . .	218
67. Red Clover (Fream) . . . . .	225
68. White Clover (Fream) . . . . .	225
69. Crimson Clover (Fream) . . . . .	226
70. Yellow Suckling Clover (Fream) . . . . .	226
71. Trefoil (Fream) . . . . .	227
72. Lucerne (Fream) . . . . .	227
73. Sainfoin (Fream) . . . . .	228
74. Tares (Fream) . . . . .	228
75. Birdsfoot Trefoil (Fream) . . . . .	228
76. Kidney Vetch (Fream) . . . . .	229
77. Corn feed regulator and magnetic apparatus, for removing wire, nails, screws, pins, etc., from grain, by passing it over a magnetic surface . . . . .	267
78. Oil Cake Breaker (Barford and Perkins) . . . . .	268
79. Vertical Steaming Apparatus (Richmond and Chandler) . . . . .	270
80. Model Set of Food-Preparing Machinery (Barford and Perkins) . . . . .	271
81. Corn Meters for use in private stables . . . . .	272



FIG.	PAGE
82. A Damp-proof Course . . . . .	276
83. Vitrified Damp-proof Course . . . . .	277
84. Ridge Ventilator with Louvre . . . . .	278
85. Open Roof . . . . .	278
86. Open Board Roof . . . . .	279
87. Vitrified Paving-brick (St. Pancras Iron Works Company) . . . . .	282
88. Vitrified Paving-brick with Single Groove . . . . .	284
89. High-class Stable (Musgrave) . . . . .	<i>To face</i> 286
90. Industrial Stable arranged on Sanitary Principles (Musgrave) . . . . .	<i>To face</i> 287
91. Ground Plan of Stable with four stalls and two boxes . . . . .	287
92. Transverse Arrangement of Stalls . . . . .	287
93. Ground Plan of Stable for thirty horses with ten loose boxes . . . . .	288
94. Ground Plan of Stable with double row . . . . .	288
95. Transverse Section of Stable with living rooms overhead . . . . .	289
96. Sheringham Ventilating Window (Musgrave) . . . . .	289
97. Ventilating Window (Musgrave) . . . . .	290
98. Ground Plan and Section of Industrial Stable, showing two double rows of horses between opposite sources of air supply . . . . .	291
99. Harmless Latch. Latch seen in Section (St. Pancras) . . . . .	291
100. Harmless Latch. Inside View of Fig. 100 . . . . .	292
101. Flush Handle, sliding door for loose box (Musgrave) . . . . .	292
102. Iron-panelled Stall Division with a Solid Head and Double Barrier (Musgrave) . . . . .	294
103. Ventilating Trellis-panel with Single Barrier (Musgrave) . . . . .	295
104. A wooden Stall Division with Solid Head . . . . .	296
105. Ornamental Stall Division . . . . .	297
106. Loose Box Division . . . . .	298
107. Loose Box Division (Musgrave) . . . . .	299
108. Loose Box Manger . . . . .	299
109. Manger and hay-rack, the former provided with roller guards . . . . .	300
110. Manger with sliding hay-guard and Water Vessel (Musgrave) . . . . .	301
111. Section of sliding hay-guard seen in Fig. 110 (Musgrave) . . . . .	302
112. Manger fittings, with hay-rack let into the wall and manger sloping away from the knees (Musgrave) . . . . .	303
113. Noiseless fastening (Musgrave) . . . . .	304
114. Sliding ring on bar (St. Pancras) . . . . .	304
115. Noiseless fastening (Musgrave) . . . . .	305
116. Collar Chain, with Spring Hook and Counterpoise . . . . .	305
117. Ground-plan of Industrial Stable for forty-eight horses . . . . .	309
118. Bad Block Plans . . . . .	310
119. Good Block Plans . . . . .	310
120. Pavilion system of stables for 480 horses . . . . .	311
121. Army bail made of iron . . . . .	311
122. Bail hook which is released by pulling up the link . . . . .	311
123. Simple plank bail, either suspended from above or from a heel post . . . . .	312
124. A compound bail with kicking-piece attached . . . . .	312
125. A deep bail . . . . .	313
126. Bail to prevent injury from the chain or rope, when the horse kicks over the bail . . . . .	314

FIG.	PAGE
127. Manger for industrial stable ; shows also method of tying, viz., a sliding ring on a bar placed on either side (St. Pancras)	315
128. Removable manger pan (St. Pancras)	316
129. Iron Fittings for Cow-sheds (Musgrave)	<i>To face</i> 325
130. Ground-plan of Cow-shed	327
131. Arrangement of Cow-shed Floor as recommended by Lloyd	329
132. Single Byre (Henderson)	331
133. Double byre (Henderson)	332
134. Double byre (Henderson)	333
135. Ground-plan and Section of an Insanitary and badly-arranged Cow-house	335
136. The same Cow-house shown in Fig. 135, but now remodelled so that it is converted into a sanitary and convenient building	336
137. Calf-pen and yard	337
138. Portion of ground-plan of Covered Homestead	342
139. Box and yard used for fattening animals	343
140. Mr. Tommas's piggery	347
141. Iron Fittings for Piggeries (Musgrave)	<i>To face</i> 348
142. Buildings for Sheep	349
143. Shelter cloths for sheep	350
144. " " "	350
145. Plan of sheep fold for lambing (Scott)	351
146. Floor laid with the Paving Brick shown in Fig. 88, and Iron Surface-drain	361
147. Covered Surface-drain with Movable Cover	362
148. Vitrified Blue Paving Brick	363
149. Vitrified Blue Paving Brick	363
150. Vitrified Blue Paving Brick	364
151. Vitrified Blue Paving Brick	364
152. Methods of laying Paving Bricks in Stalls.	365
153. Loose Box Paving	365
154. Access Pipe	368
155. Single Junction, with Diminishing Pipe	368
156. A Bend	368
157. Buchan's Disconnecting Syphon	372
158. Ventilation of stable drains	373
159. Ventilating Syphon	374
160. Access Syphon	374
161. A Simple Syphon	374
162. The Bell Trap	374
163. Section of a Stable Trap with a Fixed Syphon and Tray. The Exterior of Fig. 163	374
164. Fixed Syphon Stable Trap with removable Bucket	375
165. Fixed Syphon Trap for Stables, with removable bucket for catch- ing solids	376
166. A Gully Trap	376
167. Spray Pump, small size, arranged to work from a bucket (Deeming Co.)	407
168. The Spray Nozzle, adjustable to any degree of fineness, and throwing a fine mist-like spray	407

FIG.	PAGE
169. Spray Pump, arranged on barrel cart, for disinfecting . . . . .	407
170. Spray Pump, arranged for either disinfecting or limewashing . . . . .	408
171. Ground-plan of Trench . . . . .	413
172. Section in the length of the Trench . . . . .	413
173. Body arranged for Field Cremation . . . . .	414
174. Incinerator for Animals (Manlove and Alliott) . . . . . <i>To face</i>	414
175. Life Stages of the Bont Tick which produces Heart Water in Sheep (Lounsbury) . . . . .	419
176. Cattle-dipping Tank . . . . .	423
177. <i>Tabanus bovis</i> , the Ox Gad-fly (MacDougall) . . . . .	426
178. <i>Hematopota pluvialis</i> , the Cleg or Horse Breeze-fly (MacDougall) . . . . .	427
179. <i>Chrysops caccutiens</i> (MacDougall) . . . . .	427
180. <i>Hypoderma bovis</i> (MacDougall) . . . . .	428
181. Larva of <i>Hypoderma bovis</i> (MacDougall) . . . . .	428
182. Eggs of <i>Gastrophilus equi</i> attached to hair of horse and showing larva <i>in situ</i> (MacDougall) . . . . .	429
183. <i>Stomoxys calcitrans</i> (MacDougall) . . . . .	431
184. <i>Melophagus ovinus</i> , the Sheep Louse-fly, Ked or Kade, magnified (Neumann-Fleming) . . . . .	433
185. <i>Hippobosca equina</i> (MacDougall) . . . . .	434
186. Diagram of the Cycle of Development of <i>Hæmoproteus</i> . (After Schaudim) . . . . .	448
187. Diagram of Ehrlich's Side Chain Theory of Immunity (Dr. L. Aschoff) . . . . .	460
188. Chart showing the yearly fluctuations and the total number of re- ported cases of Glanders in Great Britain, 1881-1903 . . . . .	556
189. Showing a tuberculous and non-tuberculous Thermometric Curve after the injection of tuberculin . . . . .	580
190. Showing method of securing calf for operation . . . . . <i>To face</i>	644
191. Appearance of Vesicles produced by linear incision—120 hours . . . . . <i>To face</i>	644
192. Appearance of agar-agar plate inoculated with one loopful of glycerinated lymph at the time of admixture, and subsequently incubated 48 hours . . . . . <i>To face</i>	646
193. Agar-agar plate inoculated from the same lymph and under the same conditions as that shown in Fig. 192 after three weeks' storage with glycerine . . . . . <i>To face</i>	646
194. The Becker-Ullman Cooking or Destroying Apparatus . . . . .	680
195. The Podewill Destructor for Diseased Carcasses (Schwarz) . . . . .	682
196. Shoe to prevent stumbling . . . . .	783
197. A deep rut . . . . .	785
198. A shallow rut . . . . .	785
199. A shallow rut with rise at opposite side . . . . .	785
200. Fixed and loose stones . . . . .	786
201. An irregular surface . . . . .	816
202. Section through the 8th Bone of the Back . . . . .	816
203. Section through the 17th Bone of the Back . . . . .	825
204. The Position of Collar Injuries . . . . .	825
205. Adjustable Whippetrees to enable three horses to work abreast (Ransomes, Sims and Jefferies) . . . . .	829

FIG.	PAGE
206. Equalizing Chain and Pulley for four horses to insure each animal takes its share of the work (Ransomes, Sims and Jefferies) . . .	829
207. Inside 'Stell' for sheep protection (Stephens) . . . . .	856
208. Outside 'Stell' with plantation (Stephens) . . . . .	856
209. Outside 'Stell' without plantation (Stephens) . . . . .	856
210. Portion of Deck Plan, showing four rows of horses . . . . .	904
211. Front view of Horse Stall on Board Ship . . . . .	905
212. Rear Stanchions viewed from the front . . . . .	906
213. Side view of Stall, without rear stanchions or passage behind the horse . . . . .	907
214. Diagram of truck loaded with horses . . . . .	927
215. Ambulance for Animals for transit by road . . . . .	931
216. Diagram of Plan of Veterinary Hospital in South Africa . . . . .	943
217. Method of Tying up a Group of Horses for Leading . . . . .	953
218. Diagrammatic representation of the Weight carried by a Cavalry Horse . . . . .	963
219. Isometrical Plan of a Remount Depôt <span style="float: right;"><i>To face</i></span>	973
220. Showing type of wire fencing for Remount Depôts, also method of supporting the uprights for the gates and other main posts	973
221. Diagram of a Plan of the 'Crush' . . . . .	978
222. Section of gangway . . . . .	979
223. Elevation of gangway on the right side, showing the uprights . . . . .	979
224. Elevation of gangway on the left side, showing uprights . . . . .	980
225. Two-way gate seen at the end of the gangway in Fig. 221 . . . . .	980

## INTRODUCTION

EIGHTEEN years ago, when the first edition of this book appeared, no interest was taken in Veterinary Hygiene outside the profession, and even within it the subject was not taught in the schools, nor formed part of the examination of the Royal College of Veterinary Surgeons.

During the last few years the interest taken in the matter has been phenomenal; the particular lines along which it has travelled have been in relation to State and Municipal Hygiene, especially the latter, for the necessity of placing the Inspection of both Meat and Milk on an organized basis and under properly trained experts is beginning to be generally recognised.

The time is at hand when Veterinary Officers of Health will have to be created throughout the Kingdom, as a branch of preventive medicine safeguarding the public health. Such appointments will in no way clash with Medical Officers of Health, nor is one subordinate to the other; both confine themselves to the special animal they are trained to deal with, and the only duties they have in common are those of watching over the interests of the public health, for which purpose co-operation on both sides is essential.

The other public department in which the Veterinary profession will have to take a larger share than in the past, is the State Control of Contagious and Infectious Animal Diseases. The early history of this Department, its failures and successes, its strength and its weakness, have been fully dealt with in Chapter XI. The only point to which we would here refer, is the branch of the public service to

which the Veterinary Department should belong. Both the Medical and Veterinary Departments were originally a branch of the Privy Council; eventually they were cut off from this, the Medical passing to the Local Government Board, while the Veterinary passed to the Board of Agriculture.

Public expert departments are not of much use unless their views can reach the Cabinet, and the Minister of Agriculture was a convenient mouthpiece for conveying to the Government the best advice on the matter of contagious and infectious animal diseases. Unfortunately, however, the Agricultural Department took charge of its Veterinary Section, filled important posts with laymen, accepted or refused expert advice as it thought fit, has ventured to instruct the profession on matters of pathology, and to show the extent to which lay control is prepared to go, furnishes an Annual Report on Animal Diseases to Parliament!

All this might be regarded with some show of toleration, if the control of those diseases specially vested in their hands was carried out in an effective manner, or if they intelligently employed the immense powers placed in their hands by Act of Parliament. But throughout their object has been to throw upon the Local Authorities work which should be centralized, and when compelled to take it up themselves, have employed laymen to carry out some of its most important and technical features.

It is perfectly certain if the country is to receive the full benefit of the veterinary advice which is available, the Agricultural Department in its relation to Veterinary State Medicine must either undergo a profound modification, or the Veterinary Service must be transferred elsewhere and a fresh Ministerial mouthpiece found.

It has been suggested to establish a Central Board of Health, having a Medical and Veterinary side, with a Minister of Public Health responsible to the country. We are decidedly in favour of such a scheme. A Central Board of Health is by no means a new idea; one came into

existence in 1831, the result of the Cholera scare, and was the nucleus of the present Medical Department of the Local Government Board, in the same way as the Veterinary Department was formed in 1865 as the result of the Cattle Plague scare.

A Central Board of Health, with its independent Medical and Veterinary Sections, would be capable of performing infinitely better service than at present, while the Agricultural Department could be left to deal exclusively with Agricultural matters—such, for example, as Statistics relating to Crops, Areas under Cultivation, Animal Population, Markets and Fairs, Imports and Exports of Animals, etc., duties for which their constitution is adapted.

We recommend the entire withdrawal of all veterinary matters from the Board of Agriculture, and the re-erection of the Veterinary Department under the wing of a Minister of Public Health. This central body to take charge of the duties of the eradication of animal diseases, nothing being left to the discretionary powers of Local Authorities, who are merely the machinery on the spot for carrying out the orders of the Central Authority. With this must follow the abolition of all lay Inspectors, the whole of their duties being carried out by Veterinary Officers of Health; these must be specially qualified members of the profession independent of private practice, and each having his own subordinate staff to assist in carrying on the work.

There is every indication of the willingness of Universities to confer a Veterinary Degree in Public Health, which is abundant evidence of the importance and general interest now being taken in the question. The feeling that Veterinary Surgeons are unsuited to occupy a public position in matters of State and Municipal Hygiene is fast dying out, for which we have to thank enlightened public opinion and an educated profession.

It has taken the public a long time to recognise that our work is highly specialized, and that no medical man or layman can possibly take the place of the trained expert in veterinary matters. The tutelage of the medical profession

has been finally withdrawn, a step recognised on both sides as essential to progress and development.

The advances made in veterinary hygiene in all our colonies are matters for sincere congratulation. It is greatly regretted that the astonishing development in the veterinary inspection of meat in New Zealand could not have been embodied in Chapter XII., but the details were only recently known to us. This model and advanced colony is a profound object-lesson to the mother-country; as a profession we are indebted to the enlightenment of its Legislature, and to the capability of its veterinary adviser, Mr. Gilruth.

The researches of the latter gentleman in connection with hepatic cirrhosis of animals, due to feeding on Ragwort (*Senecio Jacobæa*), have been regretfully overlooked in the section dealing with poisonous plants.

In the same way, through an oversight, we failed to give to Mr. Borthwick, M.R.C.V.S., Veterinary Department, Cape of Good Hope, the credit for proving that the disease described at the foot of p. 190 as due to *Lessertia annularis* is really caused by quite a distinct plant, *Cotyledon ventricosa*.

We again urge on the Royal Society for the Prevention of Cruelty to Animals to take up and campaign against the cruelty inflicted on animals by insanitary surroundings, defective ventilation, overcrowding, neglect of or defective shoeing, underfeeding and overworking, badly adjusted loads, vans and waggons without or with only imperfectly acting breaks, ungreased axles, and other forms of cruelty, less obvious, perhaps, than lameness and wounds, but of far greater general importance. Here, indeed, is a rich harvest awaiting the Society, a perfectly untrodden field with immense possibilities for doing good on a large scale, and controlling much of the waste of animal life which at present exists in all cities and towns.



# VETERINARY HYGIENE

## CHAPTER I

### WATER

THE supply of water to a community is a problem which has for centuries compelled public attention, and in the hands of the Romans was more liberally dealt with than at any subsequent period. The part played by water in the production of disease has, on the other hand, only within comparatively recent years received any serious attention.

It seems pretty clearly proved that people cannot drink with impunity the polluted water of wells or rivers, and a great deal of our sanitary legislation in recent years has been directed to the supply of a pure source for towns and cities. Yet the source of all water is rain, and it is quite clearly established that rain as it reaches the earth is practically free from organic and inorganic matter. The subsequent organic impurity of water must, therefore, be owing to the soiling of the earth by the agency of men and animals, but especially the former.

If rain yielded all the water required by a community, the simplest precautions would prevent it becoming mixed with filth ; but no hamlet, let alone city, can depend upon the direct rainfall for its water supply, it has to be supplemented by that from rivers and wells, and the rain in its passage to either of these may undergo serious pollution.

The earth is dirty, the inhabited parts have been undergoing the process of pollution for centuries, and though there are agencies present constantly tending to revivify and purify it, it is certain these were only intended to be of benefit when men and animals were but two or three to the square mile, and not thousands as at present, in our towns and cities.

This congestion of definite areas has led to the community poisoning itself in the matter of water, and legislation now recognises that local supply is no longer sufficient in quantity or quality to provide the needs of some of our large cities, so that the supply of water from a clean 'catchment area,' which may be many miles away, appears the only solution of the problem.

Further, it is astonishing to bear in mind that in the past, the arrangement for the source of water supply to towns and cities was as a rule the sewage outlet. It is incredible that any community could have regarded with satisfaction or safety, a water supply drawn from the identical channel into which was poured the urine, fæces, slop-water, and street drainage of the city!

Quite apart from the possible risk which was run, one would have thought the æsthetic sense would have revolted against such a filthy system.

The part played by water in the dissemination of enteric and cholera in man appears quite clear. If either of the poisons of these diseases obtain access to the public drinking supply, there is no doubt of the results. Excepting for these two diseases we would have heard but little of the risk of water impurity.

No disease directly or indirectly related to the above affects the lower animals. Ulcerations of the bowels may exist without the disease being even allied to human enteric. The absence, then, of enteric and cholera amongst the lower animals, is the explanation why so little importance is attached to their water supply, and that anything is considered good enough for them to drink.

But there is a broader light in which the matter should

be looked at. Although we may have few diseases among animals directly attributed to an impure water supply, yet physiology and experience teach us that the highest degree of health is only obtained when that supply is above reproach, and where this is not so it is attended, if not by disease, certainly by a loss of physical fitness, and this loss is especially seen amongst the working class, viz. horses.

#### SOURCES OF WATER.

The original source of all water is rain. It makes no difference whether the water is bubbling up from the bowels of the earth, or running in a brook, it was originally obtained from the clouds. Rain on reaching the earth behaves as follows;—it either percolates, or depending on the configuration of the ground it runs off to the nearest channel and thence to streams and rivers, or it evaporates.

As a rule two, sometimes three, of these processes are operating at the same time. The amount of percolation depends upon the porosity of the soil and the time of year; the proportion which runs to brooks and rivers depends upon the impervious nature of the soil and the slope of the ground; the amount evaporated depends upon the time of year and the temperature of the air.

In sand and gravel considerable percolation occurs, as much as 90 per cent. of the rainfall may thus be disposed of; in chalk 37 per cent. may percolate, in new red sandstone 25 per cent., in magnesium limestone 20 per cent. The portion which percolates is returned to the surface by springs, wells and borings.

As the water passes into the earth it is constantly moving, and traversing the cracks and fissures which exist in the deeper formations. It also absorbs carbonic acid, as the air in the earth is many times richer in this gas than water. By dissolving carbonic acid, the capacity for attacking and dissolving much of the mineral matter it meets with is greatly increased. The original water as it reached

the earth was free from any inorganic matter, what is commonly known as 'soft,' it now becomes 'hard' in consequence of the amount of lime, magnesia, etc., it has taken up.

In its passage through the various layers forming the crust of the earth, the ground water, as it is called, at last meets a layer of impervious rock through which it cannot pass, excepting through such cracks or joints as the rock may contain. This impervious layer causes the flow of water to turn aside, and seek by the action of gravity an escape through a neighbouring pervious layer.

This is the principle which governs the production of all springs, wells, and borings. The water collecting area of a boring may be many miles away, in the case of the great well at Artois, from which the term artesian is derived, the water enters the earth sixty miles away.

*Springs* are simply the outlet of the underground water, and the yield from them depends upon the rainfall on the collecting area. Some springs are known to originate at a considerable depth, perhaps some miles, in the earth. These are designated deep springs, their water is often at a high temperature, and so charged with mineral matter as to be useless for drinking purposes, though of medicinal value.

In the case of London a pervious layer of chalk exists at some depth below the city, which comes to the surface many miles away in the hills found to the north, west and south of the London basin. Over this pervious layer is a bed of clay known as London Clay, quite impervious, and to reach the water in the chalk this clay must be bored through.

Springs may be a considerable source of supply to rivers. There are springs in the bed of the Thames near Windsor calculated to deliver 300,000,000 gallons of water daily into the river.

The ordinary summer rainfall does not undergo percolation, but owing to the temperature of the air it is removed by the process of evaporation, both direct evaporation

from the ground, and also from the leaves of plants. In very wet seasons percolation as well as evaporation occurs.

The rainfall in England averages 30 inches a year, after deducting loss from evaporation, the amount collected from the roof space—calculated at 60 square feet per head—amounts to 748 gallons a year, or two gallons per person daily.

An inch of rain delivers a little over four and a half gallons on every square yard of land, or 101 tons per square acre. In its passage through the air it becomes highly aerated, and absorbs such impurities as may be in the air, especially those found in the air of cities or the vicinity of manufacturing towns. Ammoniacal salts, nitric and nitrous acids, sulphurous acid, and the products of coal combustion, may all be found in greater or less amounts depending on the locality. The rain simply washes the air, and depending upon the amount of impurity in the latter is the impurity or otherwise of the rain water. It also carries down with it numerous micro-organisms, mainly micrococci; these are much more abundant in the first rain that falls, particularly after a prolonged drought.

*Collection of Water.*—For the supply of large cities it has been found that the best source of water is obtained either from natural or artificial lakes, which collect the upland surface water from hills. Such water is very pure, contains but a small amount of mineral matter, and is practically free from contamination. The scheme of bringing the drinking supply to Glasgow from Loch Katrine 34 miles away, to Manchester from a distance of 90 miles, and other cities from sources at a considerable distance, is a bold one, and has been attended by the best results. The pure soft water of Loch Katrine has greatly raised the standard of health in Glasgow, while at the same time it is said to save £36,000 a year in soap.

Water collected in large basins or lakes is liable to a vegetable growth, which though it colours and even

imparts a taste and odour to the water is said to be innocuous.

A scum like green paint growing on the surface of a lake in Australia was found to be very poisonous to animals, but as a rule it may be said growing vegetable matter in water is harmless. It may even be productive of good, for it was shown some years ago in India, that after all living vegetable matter had, in accordance with an order, been cleared out of the lakes (tanks) used for storing drinking water, the same became unfit for use. It was apparently the oxidizing power of the water-plants which kept the water pure.

*River Water* is as a rule pure enough at its source, but gradually becomes more and more contaminated on its way to the sea, depending upon the number of towns on its banks.

Prior to the water supply of towns and cities being taken in hand by legislation, these derived their drinking water from, and emptied their sewage into, the same river. It was usual to empty the sewage below the point at which the town supply of water was drawn, but inasmuch as there might have been a dozen towns on the same river each pursuing this course, the element of safety was a slender one. Such a system converted a river into an open sewer, and it is important, as the system still exists, to inquire whether rivers so polluted are capable in any way of purification and by what means.

It is certain that the process of oxidation and sunlight can work great changes, especially if there is a good current in the river, or agitation of the water by means of weirs or flowing over rapids; these are capable under the influence of bacteria of considerably purifying the water, perhaps even of rendering it harmless. Not that drinking excreta-infected water is dangerous or harmful in itself, it is so enormously diluted as to be harmless so far as poisonous properties are concerned, but if such water is infected with enteric or cholera the matter is quite different. The specific microbe of these diseases, it is true, appears to have a very short life in rivers, but

during that life they are remarkably active. A polluted river may continue to supply a town with drinking water which produces no harm, until pathogenic microbes find their way in.

*Wells* are described as deep, shallow, and artesian. The source of water in these we have previously considered. A deep well is generally stated to be anything over 50 feet, and a shallow well as being under 50 feet deep. This definition is rather arbitrary. Sutton\* tells us it is evident that no very definite distinction can be drawn between deep and shallow wells. There are many considerations which qualify the definition of a deep well. It may be considered essentially as one the water in which has filtered through a considerable thickness of porous material, and whether the shaft of such a well is deep or shallow will depend on circumstances. If the shaft passes through clay or other impervious stratum, and the surface water is thus rigidly excluded, the well should be classed as deep, even if the shaft is only a few feet in depth, because the water in it must have passed for a considerable distance below the clay. On the other hand, however deep the shaft of the well is, it must be considered as shallow if water can enter it near the surface, or large cracks or fissures give passage to surface water through the rock in which the well is sunk.

In shallow wells the depth of the soil through which the surface water is filtered before entering is rarely sufficient to get rid of its impurities by oxidation, though it is often sufficient to decolourize it, and by its absorption of carbonic acid give it a bright, sparkling appearance, which may be most deceptive.

The chief source of shallow well pollution is the cesspool. These latter are often purposely made pervious, so that the liquid portions find their way into the soil and only the solids remain. In this condition the cesspool will not require to be cleaned out perhaps for years. The percolating liquid joins the ground water, which as previously stated is

\* 'Volumetric Analysis.'

always flowing in the direction of its outlet, and if a well has been sunk so as to catch this ground-water, it also catches the fluid parts of the cesspit.

Further, the greater the demand on a well the larger the area drained by it, so that though the well may be placed on ground above the cesspit, and thus under ordinary conditions moderately safe, yet when a great demand is made upon it, the fluid in the cesspit below may contribute.

A well drains an extent of ground represented by an inverted cone, the radius of which is at least four times its depth, sometimes even more, as when the drain on the well is considerable.

In choosing a site for a well, the distance of any possible polluting source should be from 100 to 160 times the depth measured to the surface of the water, even greater if the lowering of the water in the well is likely to be considerable.

Every care should be taken to exclude surface-water from passing into wells. Much may be done by making the shaft water-tight by brickwork and a cement lining. In the case of a shallow well this should be carried down to the level of the water. The well should be protected by a cover, and a coping to prevent surface-water finding its way in; the water should be drawn by a pump.

Artesian wells are of great depth, the water supplying them is generally confined in a reservoir between two impervious rocks; it finds its way there through a pervious stratum which comes out on the surface of the ground, perhaps some considerable distance away. When the reservoir is tapped, the water at once rises to regain its level.

The water from deep wells is generally pure, that from artesian is organically very pure, though at the same time it may be very hard. Shallow well-water must always be regarded with suspicion.

The following *Classification of Waters* is given by the Rivers Pollution Commissioners:



Wholesome.	{	1. Spring-water.	} Very palatable.
		2. Deep well-water.	
Suspicious.	{	3. Upland surface-water.	} Moderately palatable.
		4. Stored rain-water.	
Dangerous.	{	5. Surface-water from cultivated land.	} Palatable.
		6. River - water to which sewage gains access.	
		7. Shallow well-water.	

Hygienically the classification would be as follows: 1. Pure and wholesome water; 2. Usable; 3. Suspicious; 4. Impure. The characteristics of a pure water are absence of colour, taste, smell, or extreme hardness; the more a water deviates from this, so will it pass into the other classes named.

#### IMPURITIES FOUND IN WATER.

The impurities found in water are of various kinds, but may be generally stated to be organic and inorganic. The organic impurities are animal and vegetable substances in all forms, from disease-producing matter to harmless vegetable growths. The inorganic impurities are the salts of the metals. These impurities obtain entrance into the water in various ways, either at its source or during its passage through rivers, canals, or pipes, or even after its delivery to the place of consumption. The impurities obtained at its origin will depend upon the geological formation of the soil in which the source is situated. If the ground is charged with the products of animal excreta and refuse, the water derived from it will contain these products in solution; but it is evident that some soils or formations are more impure than others, and this difference in the degree of soil impurity depends upon the power the ground possesses of oxidizing or destroying the filth which is carried into it. Where rapid destruction of this occurs, we may expect to find a purer water than in formations where it does not occur. Moreover, the porosity of the soil, especially when of great

depth, will considerably assist in purifying the water by acting as a natural filter.

It is evident that in deep porous soils, where rapid oxidation and destruction of organic matter occurs, we may look for water of a pure type, and the more we depart from these conditions the more impure will the water be. Again, the presence of the salts of metals in great abundance in the formation will affect the purity of a water, for lime, magnesia, soda, potash, iron, and alumina, are very readily acted upon by the water passing through the soil, and rapidly taken up in solution.

In gravel formations it is usual to find a pure water, particularly away from towns. Where clay exists the water is usually impure; in alluvial formations it is generally bad; in limestone and chalk districts the water is often organically pure, but contains a large amount of mineral substances, as lime and magnesia, rendering it exceedingly hard. Surface waters, especially from cultivated lands, and marsh waters, are generally very impure from the amount of organic matter they contain.

During the passage of water through rivers or canals, the principal impurities which obtain an entrance are sewage and manufacturing refuse; the latter is derived from bone-boilers, bleach-works, tanneries, etc. The importance of this class of impurity is considerable.

The impurities found in wells are derived from surface-washings, and soakage through soil impregnated with organic matter; from leaking pipes or cesspits containing animal excreta, and the leakage finding its way into the soil to be carried to the nearest well. Shallow wells near buildings or stables, or close to manure-pits, are simply receptacles for filth.

*Hardness of Water.*—As previously mentioned, water as it falls from the clouds possesses no mineral matter in solution, excepting in the vicinity of the sea. Rain-water readily combines with soap to form a lather, and from the peculiar feel it imparts to the fingers is known as 'soft.'

In its passage through the earth, salts of lime and mag-

nesia are dissolved and taken up by the water in the manner previously described. Such water can only with difficulty form a lather with soap, and imparts a feeling to the fingers known as 'hard.' Hardness in water may be due to calcium carbonate, sulphate, or chloride, or to magnesium carbonate; that which is due to calcium carbonate can readily be removed and is spoken of as temporary hardness, but the other salts, generally speaking, are not capable of being removed and produce permanent hardness.

When water is boiled its carbonic acid gas is driven off, and the chalk no longer being kept in solution is deposited. Such deposits are familiar in vessels used for boiling water. As the result of the deposition of chalk the water becomes much softer; the same result can be obtained in another way, which will be alluded to presently.

No lather can be formed with soap so long as salts of lime or magnesia remain in solution, for these combine with the fatty acids of the soap and form a curd. It is not until the salts are entirely precipitated that a lather can be formed, so that much waste of soap occurs, in fact one grain of lime wastes eight grains of soap. Advantage is taken of the action of soap on lime and magnesia, to use it as a test of the amount of hardness in water.

Rain-water contains less than half a grain of lime per gallon; a water containing more than ten grains of lime or its equivalent per gallon, is described as 'hard.'

*Action of Water on Metal Pipes.*—Lead pipes are largely used for the conveyance of water, and depending upon the character of the water, the metal is more or less attacked and enters into solution. In this way many cases of lead-poisoning have occurred in man. Soft water is particularly liable to act on lead and dissolve it. Certain soft waters do this with greater facility than others; for example, the waters of Huddersfield and Sheffield have a marked effect on new lead. Several theories have been propounded to explain why one soft water should, and another should not, act on lead. The presence of a small amount of silica in

the water is urged as one explanation of protection ; while the presence of humic acid in certain peaty upland waters, is said to have a marked dissolving action on lead.

Hard water has very little action on lead, for the pipe is soon coated by a carbonate, and all further action ceases.

Iron pipes are used as mains, to prevent water rusting and corroding them they are coated with a vitreous glaze.

In the *Storage of Water* galvanized iron cisterns are largely used and are safe ; iron cisterns discolour the water but do no harm ; zinc vessels may be acted upon ; slate vessels are excellent but liable to leakage at the joints. Wooden vessels for water storage are bad, and though largely used as water-troughs they are liable to contamination and the growth of organisms.

The *Purification of Water* for animals, does not bear such an important position as it does in the case of human beings, owing to the absence of such diseases as typhoid, cholera, and dysentery. But for the highest degree of health good and pure water is essential.

The objects aimed at in the purification of water on a large scale are freeing it from organic matter, and getting rid of inorganic if it is in excess. The former is obtained by *filtration*, and is employed by all Water Companies who obtain their supply from rivers, and other polluted sources. The filter-beds consist of gravel of different degrees of coarseness, on the top of which are layers of sand a foot in thickness, the finest sand being on the top.

For effective filtration the passage of the water through the filter-bed must be slow ; to ensure this the depth of water on the filtering layer is not more than two feet. The action of this class of filter is very simple ; the organic matter in the water forms a gelatinous deposit on the surface of the sand, consisting of organisms of various kinds. The gelatinous mass acts as a filter, refusing to allow other bacteria to pass, and so long as the gelatinous growth remains unbroken, filtration is effective. When the slimy layer grows down too far into the sand, filtration becomes slow and the surface has to be cleaned.

The *Removal of Hardness* from water on a large scale is brought about by what is known as Clark's process. The principle involved is the precipitation of the lime by converting it into an insoluble carbonate. This is accomplished by adding lime-water to the hard water and well mixing. The lime-water combines with the carbonic acid holding the chalk in solution, and the latter is precipitated.

By this process several degrees of temporary hardness may be removed from water. Thames water may be reduced from 16 degrees to 4 degrees of hardness.\* At the same time a certain amount of organic matter is also removed by this method.

Clark's process does not reduce the permanent hardness of water, which is due to calcium sulphate or chloride, or to salts of magnesium.

#### EXAMINATION OF WATER FOR HYGIENIC PURPOSES.

The object of a water analysis is to determine whether any organic pollution has occurred, or whether the inorganic substances are in excess.

It is by no means easy for the untrained mind to grasp the significance of chlorine, ammonia, etc., as revealed in the results of a chemical analysis, nor is it even always possible for the chemist to make an accurate judgment of any given water as based on his analysis.

If the organic substances which pollute water were on analysis met with in the form in which they entered it, an examination would be comparatively easy, but this is not so; fæces, urine, and filth are not met with in water as such. They have all undergone decomposition, and yielded simpler chemical compounds or elements, and it is only by the isolation of the elements or compounds that a guess is made as to their probable origin.

Ammonia in the form of free and organic ammonia is one of the most important determinations in water analysis, not

\* One degree of hardness is equal to 1 grain of calcium carbonate per gallon.

because the bodies are in themselves harmful, but because they indicate the existence of nitrogenous organic matter. This organic matter may be due to a minute portion of enteric stool, or a piece of decomposing leaf. Which it is the chemist certainly cannot determine, all he can do is to draw attention to the existence of free and albuminoid ammonia, point out that they exist in far larger amounts than should be found in good water, and hazard a guess from the remainder of the analysis as to their origin.

Chlorine, in the same way, is used solely as an index of the organic matter which may have obtained access to the water. The amount of chlorides in a good drinking water is known, and anything found over and above that, assuming there is no question of the water being brackish, is believed to be due to animal contamination, for example urine.

Chlorine, sulphuric, carbonic, phosphoric, nitric and nitrous acids, combined with lime, magnesia, soda, potash, ammonia, iron, and alumina are not isolated by the chemist because in themselves they are harmful in water, for all these might be added to drinking water in the proportion found in London sewage without being in the least harmful; but they are used as an index of the purity of the water, the assumption being that compounds of the above acids and elements are only found in pure water to a well ascertained amount, and anything over and above must have been introduced from without and is an impurity.

The examination of a sample of water consists of a physical, microscopical, bacteriological and chemical inquiry.

In the *Physical Examination* is determined the colour, clearness, sediment, lustre, taste, and smell of the water. The *colour* and *clearness* of a water are obtained by putting the sample in a tall glass vessel placed upon a piece of white paper, and then looking down through the depth of water which should, if possible, be not less than 18 inches. Any marked colour by this means is readily detected. Water should have a bluish tinge; yellowish is perhaps the most common, and is probably due to fine sand or clay.

Brown waters are suspicious of sewage or other organic contamination.

The *sediment* forms usually after the specimen has stood for twelve or twenty-four hours ; to obtain it the clear water is drawn off by a syphon, and the remaining water and sediment poured into a conical glass. It will usually be found to consist of vegetable debris, in which may be detected low forms of organic life, ova of insects, parasites, etc. A microscopical examination is the only satisfactory method of dealing with it.

The *lustre* of a water is its degree of brilliancy ; the chalk waters have an exceedingly brilliant appearance, from the amount of carbonic acid they contain. The brilliancy of a water may be great, slight, or nil.

*Taste*.—Good water should have no taste, but the absence of taste does not mean freedom from pollution. Some of the worst waters from shallow wells are bright, sparkling, and entirely free from taste. Iron is the only substance in water which can be detected by taste when in small quantities.

*Smell*.—Good water should have no smell ; the best method to determine smell is to heat the water, when putrefactive gases may be recognised. A good plan with a suspected water is to put it in a warm place for a few days in a stoppered bottle half full. Both smell and turbidity may then be determined.

The opinion formed of the purity of a drinking water from the physical examination alone might be misleading, as a very unpromising *looking* water may be perfectly pure, and *vice versá*. We are, however, justified in considering, in the absence of anything more definite, that a water possessing no colour, taste, or smell, with but a slight sediment and brilliant lustre, is perfectly fit for drinking purposes.

*Microscopical Examination*.—This is undertaken with the object of determining the nature of the suspended matter, and thus have a possible clue to the nature of the contamination. But it is important to bear in mind it is not the

sediment or deposit as we see it which is harmful, but rather that which is dissolved in the water of which the sediment is only a probable index. Water may contain an abundance of animal life and vegetable growth without it being in any degree harmful. Bacteria innumerable may be present and yet none of them pathogenic. In fact, the probability of being able to hit off pathogenic organisms in drinking water is very remote, owing to the extent of the dilution.

The deposit examined microscopically may consist of living or dead vegetable matter, cotton or linen fibres, fungi, algæ, diatoms, desmids, confervæ, amœbæ, infusoria, rotifera, water-worms, water-fleas, etc.; while of animal origin may be found epithelial cells, wool fibres, hairs, or even muscular fibre. Besides these there may be found various forms of bacteria, and the ova of parasites.

Nothing very definite can be drawn from this examination; epithelial cells, but especially muscular fibre, would point to sewage contamination. From a veterinary point the existence of ova, probably those of parasites, might prove of the utmost importance.

*Bacteriological Examination* is the only real method of determining the nature of the micro-organisms found in water, but it must be made by a specialist. A given quantity of water is mixed with a nutrient medium, poured out on a plate and allowed to grow at a suitable temperature. Many colonies form on the plate and may be counted; the harmless organisms may be neglected, while those suggestively pathogenic are further cultivated and identified. The purer a water the fewer colonies found.

#### *Qualitative Examination of the Dissolved Solids.*

In the chemical examination of a drinking water, if any turbidity or suspended matter exists, it must first be removed by the process of filtration through paper before the clear liquid is subjected to the process of testing.

The following elements and acids are looked for, viz., lime, magnesia, soda, potash, ammonia, iron, alumina,



chlorine, sulphuric, carbonic, phosphoric, nitric and nitrous acids.

The significance of these, and the reason why they are looked for, has been previously dealt with. Their amount can be determined by a quantitative analysis, which like the bacteriological examination of water requires an expert. On the other hand, a qualitative examination is not only simple and easily performed with a few reagents, but for veterinary purposes conveys nearly if not all the information likely to be required.

*Reaction.*—Take the reaction of the water with test-papers, good water is usually neutral; if it is acid and the acidity disappears on boiling it is due to carbonic acid. If it is alkaline and the alkalinity disappears on boiling it is due to ammonia; this reaction, however, is extremely rare. If the water remains alkaline after boiling, the alkalinity is probably due to soda carbonate.

*Lime* is present in the form of carbonate, sulphate, chloride or nitrate. To ascertain its presence, a solution of ammonium oxalate is employed, which produces a precipitate of lime oxalate.

On the density of the precipitate obtained a rough guess of the amount of lime present may be made; it will vary from a faint haze to a well-marked turbidity. Six grains of lime to the gallon gives a marked turbidity, while sixteen grains produces a considerable precipitate. Six grains of lime per gallon may be found in the best waters, some are even softer than this.

The question of the degree and nature of the hardness in water is one frequently arising, owing to the well-founded prejudice against the use of hard water for horses. By a very simple examination it is possible to determine roughly to what salts the hardness is due, and whether any softening of the water is possible.

If the specimen of water under examination be boiled, the lime to which the temporary hardness of water is due is thrown down. Any lime now left is probably calcium sulphate, which is largely responsible for permanent hard-

ness. If the ammonium oxalate test be applied to two specimens of the water, the one in the ordinary way, the other after boiling and filtration through paper, the difference, if any, in the turbidity produced will enable an opinion to be formed as to whether the hardness is largely temporary or permanent.

A solution of soap of definite strength may also be employed in the same way. For qualitative purposes the ordinary soap liniment of the Pharmacopœia may be used, one minim of which in half an ounce of water is equal to about one and a half grains of lime to the gallon. If the number of minims employed with half an ounce of water, to produce a permanent lather on shaking, be multiplied by 1.5, the number of grains per gallon of lime is approximately known. This test can be repeated on the boiled and filtered water, as in the ammonium oxalate observation.

*Magnesia.*—To obtain this the lime must first be precipitated by ammonia oxalate and the fluid filtered; to the filtrate is now added a mixture of sodium phosphate, ammonium chloride, and liquor ammonia. A crystalline precipitate of triple phosphate forms in the course of some hours.

*Chlorine.*—If a solution of silver nitrate be added to a soluble chloride, a white precipitate insoluble in dilute nitric acid is produced. The precipitate may be a mere haze or a considerable opacity, depending entirely on the amount of chloride present. One grain of chlorine per gallon in water gives a haze, four grains a marked turbidity, and ten grains a considerable precipitate.

*Sulphuric Acid* is commonly found in association with lime, calcium sulphate being one of the causes of permanent hardness. The amount of sulphate can be roughly determined by adding barium chloride to the water, which produces a white precipitate insoluble in nitric acid. One and a half grains of sulphate per gallon gives a faint haze after standing some time, three grains gives an immediate haze and after a time a slight precipitate.

*Nitrous and Nitric Acids.*—When nitrogenous bodies break up in the process of putrefaction and decomposition, they become reduced to their simple elements. The nitrogen in them combines with hydrogen to form ammonia, while later on the ammonia by uniting with oxygen becomes oxidized to nitrous and finally to nitric acid. The nitrous acid unites with bases to form nitrites, the nitric acid forms nitrates. The determination of nitrites and nitrates in drinking-water is of the greatest importance, as a means of ascertaining the presence of nitrogenous substances undergoing change, which are presumably of animal origin, as vegetable matter yields but little of these acids to water.

Nitrous acid is formed before nitric acid; if therefore nitrites are found in the water they are regarded as indicating recent contamination, while nitrates suggest the contamination is older. Both, of course, may be found in the same sample of water, indicating that pollution is still occurring.

To detect nitrous acid add a solution of potassium iodide and starch to the water, and then dilute sulphuric acid. If nitrous acid is present an immediate blue colour is produced. It is well to make a comparative experiment with distilled water. The starch and iodide solution keeps badly so should be freshly prepared.

The most delicate test for nitrous acid is metaphenylenediamine. A few drops of this with dilute sulphuric acid produces a yellow colour, more or less immediate; if there be only one part of nitrous acid in 10,000,000 parts of water the colour will develop in half an hour.

The test for nitric acid in the absence of nitrous is brucine. A solution of this is added to the water under examination, followed by the cautious addition of a few drops of strong sulphuric acid, the test-tube being inclined so as to let the acid run down the side, and fall to the bottom without mixing. At the junction of the acid and water a pink and yellow coloured zone forms, the depth varying with the amount of acid present. This test is very delicate,

half a grain of nitric acid per gallon gives a marked colour.

If nitrous acid be present in the water the above test is unreliable. The nitrous acid can be destroyed by taking about three and a half ounces of the water, mixing with it a few drops of sulphuric acid, and as much pure urea as may be placed on the point of a knife. In the course of an hour the brucine test can be applied.

*Ammonia.*—In water this exists in two forms, viz., as *free* or saline ammonia, such as would be found were urea introduced, and secondly, as *albuminoid* or organic ammonia. Qualitative analysis makes no distinction between these forms, that comes under the head of quantitative, and special methods have to be adopted to obtain them. For ordinary qualitative analysis it is sufficient to know that ammonia is present.

The test employed is known as Nessler's, which is a compound of mercuric chloride, potash, and potassium iodide; this reagent possesses the power of detecting the existence of ammonia, even when it is present in very minute quantities. Add to a test-tube one-quarter full of the water under examination, one or two drops of Nessler's solution, shake the tube, if ammonia be present there will be a yellow colour struck at once, or it will come up after standing a few minutes.

A water may contain free ammonia, and yet give no evidence of it when the test is applied in the above way. The explanation of this is, that in spite of the delicacy of Nessler's test for ammonia, yet (unless the water be concentrated by distillation) the reaction is not obtained, excepting it is found in large amounts. If on applying Nessler's test to water which has not been distilled a markedly yellow colour forms, there need be no hesitation in rejecting such water for drinking purposes, as the amount of organic matter present must be very large to give such a deep reaction. Should there be only a pale delicate tint of colour, it will render us very suspicious of the water, and exceedingly careful over the analysis.

In order to perceive the colour formed by Nessler's test, look through a certain depth of the fluid placed over a white surface; an inch or so in a test-tube is sufficient, the least yellow tint can then be detected at once. It is of supreme importance in applying this test that the test-tube be perfectly clean and free from ammonia.

*Oxidizable Matter.*—The presence of organic matter in water not necessarily nitrogenous, may be determined by the use of an agent which by yielding up its oxygen oxidizes the organic matter which may be present. The test by itself is not a very satisfactory one, as there are bodies in water other than organic which have an affinity for oxygen.

To the solution under examination add a trace of dilute acid, and then boil for twenty minutes with a solution of gold chloride. If organic matter be present the yellow colour turns to pink, violet, olive, or even a black precipitate, depending on the amount of organic matter present; the usual colour is violet more or less deep. This test is of no use in the presence of nitrous acid.

The darkening of the silver chloride obtained by the chlorine test should also be noted; where organic matter is present it rapidly darkens. For the purpose of comparison a dilute solution of salt and water may be employed. A weak solution of permanganate of potassium may also be used, one grain to four ounces of water. A few drops of this should be added to the water under examination, sufficient to give it a delicate pink colour. If much organic matter is present the colour soon goes, varying from a few minutes to an hour. If two drops of the above solution be added to two ounces of water, the pink colour should remain for at least one and a half hours if the water be good. Unfortunately there are other substances in water besides organic matter which reduce permanganate, the test is only useful in conjunction with others.

*Phosphoric Acid.*—Pure water contains no phosphates;

water containing vegetable, and particularly animal matter such as urine and fæces, contains a decided quantity. The test is really a valuable one when carefully considered with the others. The presence of this substance is detected by adding to the water a little dilute nitric acid, and then molybdate of ammonia. If phosphoric acid be present in quantity, an immediate yellowish-green colour appears; if it be small in amount, the colour is produced on boiling the liquid.

*Lead, Copper, or Iron* may be present in water. The former is dangerous, the copper very rare, the iron harmless. Lead or copper are precipitated by ammonium sulphide, a dark or black precipitate resulting which is insoluble in hydrochloric acid. Lead may further be distinguished by the addition of crystals of potassium bichromate, which give a turbidity at once if the amount of lead present is equal to one-tenth of a grain per gallon. One-twentieth of a grain will cause a turbidity in one minute, and one-fiftieth of a grain will produce it in half an hour.

Iron, which is quite unobjectionable, is detected by the red or yellow prussiate of potash and dilute hydrochloric acid, which produce a blue colour. The yellow prussiate is used for ferric the red for ferrous salts.

*Hydrogen Sulphide* may be found in an exceedingly bad water. It is determined by its smell on boiling, or by its blackening a salt of lead.

The *Inferences from the Qualitative Tests* are thus summarised by Parkes:

If chlorine be present in considerable quantity it either comes from a strata containing salt, from impregnations of sea-water, or from the admixture of liquid excreta of animals or man. If from the first cause, viz. salt strata, the water would be alkaline from carbonate of soda; there would be an absence, or nearly so, of oxidizable organic matter as determined by the tests for nitric and nitrous acids, ammonia, and the chloride of gold tests; and there would probably be a large amount of sulphuric acid present. If

the chlorine be derived from calcium chloride, there would be a large precipitate with ammonium oxalate after boiling. If from sea-water, the chlorine would be found in very large quantities; there would also be much magnesia, and very little evidence of oxidized products of organic matter. If it be from sewage the chlorine is marked, the nitric, nitrous, phosphoric acids and ammonia largely present, and if the contamination be recent, the organic oxidizable matter would be large. A stream fouled by excreta may thus show at different times of the day different amounts of chlorine, and this in the absence of rain will certainly indicate contamination.

Ammonia is nearly always present, but in minute quantities in good water. If it can be detected without distillation it is exceedingly suspicious. If nitrates and nitrites are present they are likely to be from excreta. Nitrates found in water indicate previously existing organic matter, probably animal; nitrites indicate recent contamination. The coincidence of readily oxidizable matter, ammonia, and chlorine indicate the contamination as being of animal origin.

If a water gives the test for nitric and not nitrous acid, and there is almost an absence of ammonia, the origin of the nitric acid is not from organic matter, but probably from potassium, sodium, and calcium nitrate, derived from a soil impregnated with organic matter at some previous date. Large evidence of nitric acid, with little evidence of organic matter, indicates old contamination. If nitrous as well as nitric acid and organic matter be present, the pollution is recent. Phosphoric acid indicates an origin from phosphatic strata, or from sewage impregnation.

Lime in large quantities indicates a very hard water; if boiling removes it, it is calcium carbonate; if it has but little effect upon it, it is calcium sulphate or chloride. If sulphuric acid is large, it is in combination with lime; if the latter is small, it is combined with soda. If the water is acid and the acidity disappears on boiling, it is due to

carbonic acid; if it is alkaline and remains so after boiling, it is due to carbonate of soda.

In forming an opinion as to the quality of a water, it is most essential that the collective tests, and not a single one, should be our guide. As an example of this the subjoined table from Parkes (see p. 25) will be found useful.

It would be beyond the scope of this work to describe the quantitative analysis of water, nor is it possible for anyone to undertake this with exactitude unless in constant practice.

In order, however, to appreciate the results of a quantitative examination, it is necessary to understand the proportion in which the various substances in water may exist compatible with purity.

The following are dealt with in a quantitative analysis:—

Solids : *a*, total ; *b*, fixed ; *c*, volatile.

Chlorine.

Hardness : *a*, total ; *b*, fixed ; *c*, removable.

Free ammonia.

Albuminoid ammonia.

Oxygen required for total oxidizable matter.

Nitrous acid.

Nitric     ,,

The analyst shows his results either as grains per gallon, equivalent to parts per 70,000, or he expresses them in the metrical system, and describes them as parts per 100,000 or parts per 1,000,000.\*

So many conditions influence the quantity of each of the substances found in good drinking-water, that no hard and fast rule can be drawn in the case of any but one substance, and that is nitrous acid.

\* Parts per 100,000 are converted into grains per gallon by multiplying by 7 and dividing by 10. Conversely, grains per gallon are converted into parts per 100,000 by multiplying by 10 and dividing by 7.



TABULAR VIEW OF INFERENCES TO BE DRAWN FROM QUALITATIVE EXAMINATION.

Chlorine.	Oxidizable Matter.	Nitrates.	Nitrites.	Ammonia.	Phosphates.	Sulphates.	Classification.
Slight	Slight	Nil	Nil	Nil	Nil	Trace	Good
Marked	Nil or trace	Nil	Nil	Marked	Present	Trace	Good
Marked	Slight	Marked	Nil or trace	Trace	Trace	Trace	Usable
Large	Slight	Nil or trace	Nil	Nil	Nil or trace	Marked	Usable
Slight	Well marked	Marked or large	Nil	Nil	Nil or trace	Nil or trace	Usable
Marked	Nil or trace	Marked	Nil or trace	Marked	Marked	Marked	Suspicious
Slight	Marked	Present	Present	Marked	Trace	Trace	Impure
Marked	Large	Marked	Marked	Marked	Marked	Marked	Impure

A perfectly pure water.  
 A good water, probably from a deep well.  
 Probably old animal contamination.  
 Probably some contamination with sea-water.  
 Probably vegetable impurity - peat.  
 Probably a shallow well contaminated with urine.  
 Probably water contaminated by sewer gas.  
 Water contaminated with sewage.

The following are approximately the quantities which are found in a good water :

				Grains per	
				Gallon.	
<i>Solids.</i>					
Total	...	...	...	5·0000	The solids in chalk waters may be as high as 30 grains per gallon.
Fixed	...	...	...	4·0000	
Volatile	...	...	...	1·0000	
<i>Chlorine</i>	...	...	...	1·0000	
<i>Hardness.</i>					
Total	...	...	...	6·0000	
Fixed	...	...	...	2·0000	
<i>Free Ammonia</i>	...	...	...	·0014	
<i>Albuminoid Ammonia</i>	...	...	...	·0035	
<i>Organic Oxygen</i>	...	...	...	·0200	
<i>Nitrous Acid</i>	...	...	...	Nil	
<i>Nitric</i>	„	...	...	·0226	

Here is a table taken from Parkes\* showing the analysis of certain waters :

	Total Solid Residue.	Chlorine.	Nitrogen as Nitrates and Nitrites.	Free or Saline Ammonia.	Albuminoid Ammonia.	Hardness.
	Grains per Gallon.	Grains per Gallon.	Grains per Gallon.	Parts per Million.	Parts per Million.	Degrees.
New River Company filtered ...	17·6	1·2	0·15	0·02	0·04	15
Unfiltered Thames water at Hampton ...	32·0	1·8	0·222	0·04	0·28	16
Polluted shallow-well water ...	96·5	10·5	3·5	6·00	0·31	42
Sewage effluent from precipitation works ...	80·5	11·2	—	18·5	3·86	23

In good water the albuminoid ammonia should not exceed ·08 part per million. In the Thames water given in the table above, the albuminoid ammonia is probably vegetable as both the free ammonia and chlorine are small.

\* 'Hygiene and Public Health,' L. Parkes.

The pollution of the well-water is due to sewage, as indicated by the nitrogen, free ammonia, and chlorine (Parkes).

In the table it will be observed that nitrates and nitrites are absent from sewage. They are only found when a certain amount of oxidation of organic matters has occurred, hence their presence in polluted well and river water.

#### QUANTITY OF WATER REQUIRED.

The quantity of water required has been made the subject of many experiments. It is obvious that the amount is influenced by the time of year, and in the case of horses by the work performed. Further there are certain operations of the stable, flushing drains, washing carriages, etc., which are all included in the calculated daily supply per head.

Stating the amount in round numbers required by horses for drinking purposes alone, it may be placed at between 7 and 8 gallons daily. Rather less perhaps in the winter, rather more in the summer. The largest amount of water is generally drunk at noon, but again this depends upon the work the horse is performing.

The amount required for stable cleansing and other operations is about equal to the amount consumed; so that experience indicates 16 gallons of water per head per diem as the probable amount required.

Observations made on board a ship during the Abyssinian Expedition furnish the amount of water required by other animals for drinking purposes:—

					Gallons daily.
Elephants	...	...	...	...	25
Camels	...	...	...	...	10
Draught bullocks	...	...	...	...	6
Pack bullocks	...	...	...	...	5
Horses	...	...	...	...	6
Mules and ponies	...	...	...	...	5

The quantity of water required daily in hospitals for sick animals is difficult to determine, and must depend upon the type of case. Surgical cases cause a very heavy drain on the water supply, especially if irrigation of wounds or sprains be practised.

## DISEASES PRODUCED BY IMPURE WATER.

In spite of the immense amount of research which has been applied to the question of water and disease, it is remarkable what a very unsatisfactory condition the matter is still in.

The human hygienist can only place his finger on two diseases communicable by water, viz., cholera and enteric, and nearly all the observations which have been made in connection with water and disease bear on these two specific infections.

Nobody supposes that either of these diseases originate in water, but that the organisms gain access to it and are thus distributed. The same results would follow if scarlet fever, small-pox, diphtheria and typhus were associated with diarrhoea or bowel trouble, and through defective drainage found their way into the drinking-water; this would then become the chief medium for their distribution, whereas, of course, it is not so.

Neither cholera nor enteric affect the lower animals, but if we take the specific diseases which are peculiar to them, there is no difficulty in understanding that many of them may be water-borne.

Glanders, for example, can undoubtedly be conveyed by the drinking-water, the affected animal has only to leave behind in the trough or bucket some of the nasal discharge in order to infect the first horse that swallows it.

Swine fever may also spread through the water supply being infected with the specific microbe. Foot and mouth disease is probably commonly spread by this means, as the saliva is most infective. Cattle plague which is associated with acute diarrhoea will also be propagated in this way, should the excreta contaminate the drinking supply, and so, in fact, may any specific disease capable of infection through the digestive canal.

If, on the other hand, we are asked to indicate impurities in water which produce disease it is really a very difficult matter. It is easy to understand the production of diges-

tive disturbance by animals drinking a very hard water, or one containing a considerable quantity of mud and filth. Both of these act mechanically on the lining membrane of the digestive canal, and their results are easy of comprehension.

If we except these two conditions there is nothing in water capable of producing disease, unless specific organisms gain access to it. Yet it is beyond all shadow of doubt that a pure water supply is essential to health. Where it does not exist, although it may not be possible to precisely indicate the departure from health, yet as a practical matter there is no difficulty in recognising that the highest degree of physical efficiency, especially among horses, is not obtained where the water supply is impure.

Anything which detracts from the highest obtainable degree of health, is rendering the animal more prone to disease. The object of hygiene is to secure the greatest degree of bodily health, not only because the animal is then better suited for work or for food, but because it is less liable to disease. This question of body fitness as a protection against disease will frequently be discussed in these pages. There are certain definite factors which contribute to it, and we cannot accept for a moment the popular impression that any water is good enough for animals.

Very little headway has been made by the human hygienist over the question of the introduction of specific microbes into the water supply, his difficulty being that he has to go so far back, probably to the very origin of the supply, to be able to trace even possible infection.

In doing this he has had to assume that these organisms have maintained their vitality and infective properties for many days, and further, in spite of being diluted millions of times, it has still been possible for the infecting agent to have picked out a susceptible human being here and there.

Authorities do not appear to agree as to the length of time the microbes of the two diseases most commonly water-borne, viz., cholera and enteric, are capable of living in water; some believe but a very short time under natural

conditions, though in the laboratory their life may be found to be prolonged from one to three months.

For these reasons there has been at times great difficulty in accepting the water-borne origin of disease, but no such difficulties apply to the lower animals. Glanders, foot and mouth, swine fever and similar diseases are not transmitted along the water-mains of any company.

The water-trough or bucket in the stable, the puddle or polluted well in the farmyard are the means of infection; the water and the disease are side by side, not as in the human subject probably some miles apart.

Anthrax infection through contaminated water is possible, and many such cases have been reported, but the bulk of evidence points to the food as the chief means by which the microbe enters the body.

Parasitic diseases so common in the lower animals are largely spread by water; the ova of tape, round, and thread worms have been found in water; certain filaria such as the *filaria oculi* are undoubtedly conveyed by it, while the liver fluke of the sheep can only be transmitted by passing through an intermediate host that lives in the water or in wet places.

The attack of leeches both in the nasal passages and on the limbs of horses can only occur through water. In fact, it is possible that by far the most common source of parasitic infection of animals is through the water supply.

We have been compelled within the last few years to modify views which were previously accepted facts in connection with water and disease. It is by no means clear that any particular inorganic impurity in water accounts for goitre; it is now almost certain that while cystic calculus frequently occurs on a limestone formation, lime or hardness of the water has practically nothing to say to its production. Finally, abortion amongst animals, which has in some years from its frequency been described as epizootic, and considered to be due to the impregnation of water by sewage, is now known to be caused by a specific organism which enters from without.

## CHAPTER II

### AIR

It is scarcely necessary to dwell upon the paramount importance of pure air, we have only to remember that air is an urgent and regular necessity; food and water can be done without for hours, even a few days, but a few seconds' deprivation of air brings about an alarming change in the organism. Nor is this difficult to understand when we remember that the process of building up and destruction in the body is constantly occurring, and that nothing must interfere, even for a few seconds, with the supply of oxygen and the removal of carbonic acid.

There is no difficulty in understanding why it is that the supply of pure air to the body is so necessary, when we consider the profound changes occurring in the blood as the result of respiration. The blood must be supplied with oxygen and its carbonic acid removed; for this purpose the inspired air is brought so intimately in contact with the blood of the body, that only a membrane of extreme thinness and delicacy separates the two. Nothing can be easier than a conception of the influence on the blood, when instead of being brought in contact with a pure atmosphere, it has to effect its important chemical changes with an already vitiated mixture of gases.

*Composition of Air.*—Air is a mechanical mixture of three gases, viz., nitrogen, oxygen, and carbonic acid, with traces of ozone, ammonia, organic matter, mineral salts, and a variable proportion of watery vapour depending on the temperature.

The following is its volumetric composition—

				Per cent.
Oxygen	...	...	...	20·96
Nitrogen*	...	...	...	79·00
Carbonic acid	...	...	...	·04

It is remarkable how uniform the composition of the atmosphere is found to be in all parts of the world; even in cities it differs very slightly from the air of the country or sea; this is due to the process of diffusion, the influence of winds, the effect of rain in washing the air, and the action of plants. All of these are powerful influences in ensuring uniformity in the composition of air. Diffusion never ceases, the silent and complete mixing of different gases, even though of opposite properties and different weights, is constantly in operation; the effect of wind is naturally considerable, while the part played by the green portion of plants under the influence of sunlight, in storing up carbonic acid and liberating oxygen, is not counter-balanced by their opposite behaviour during the night of storing up oxygen and liberating carbonic acid.

These purifying forces—some of which we endeavour to imitate in the process of natural ventilation—explain the remarkable uniformity in chemical composition of the atmosphere generally.

*Oxygen* constitutes one-fifth of the atmosphere. It is the active and essential gas by which life on the globe is supported, and what may appear slight reductions in the amount present constitute the most serious deprivation.

Such reductions are found in the air of inhabited buildings, or in closed courts or streets in crowded cities, especially when the air is stagnant, as for example during fogs. In such cases the oxygen may in the open air fall as low as 20·80 per cent., and even in the absence of fogs and wind, this reduction in oxygen may be found in the crowded courts and yards of cities, where every conceivable form of

\* With this is included the new gas Argon, which amounts to about 1 per cent.



human ingenuity has been devised to interfere with the action of the wind and the penetration of sunlight.

Under the influence of respiration the oxygen of inhabited buildings is less than that of the outside air, for the reason that it is being withdrawn, and unless proper ventilation is established it is not being replaced in sufficient quantity to keep the air at a normal standard. A closed stable has been known to give as low a percentage of oxygen as 20·39. It may be said that very bad air begins when the oxygen falls as low as 20·6 per cent.

*Ozone* which is only a highly active condition of oxygen has been described as occurring in traces in the atmosphere, the result of electrical conditions.

Very little is known about it, even the tests usually employed to detect its presence are now of doubtful value.

*Nitrogen* constitutes about four-fifths of the atmosphere. It is a gas remarkable for its purely negative properties ; in our present state of knowledge it is regarded as a diluent of the oxygen, but very little is known about it. It is quite possible that what in the past has been regarded as nitrogen may turn out to be a mixture of gases. Already one of these has been discovered, viz., argon, associated to the extent of one per cent. with nitrogen.

*Argon* is as obscure as nitrogen, and just as inert ; no element has yet been found which is capable of entering into combination with it.

It is very probable the nitrogen in the air has some important function to perform in connection with plant life.

*Carbonic Acid* in the air is mainly derived from the earth ; the ground air contains 250 times more carbonic acid than the atmosphere. The average amount of carbonic acid, ·04 per cent., is not found to vary to any considerable extent, though as might be expected samples collected close to the ground contain more carbonic acid than air from the tops of mountains, while the carbonic acid in the air at sea is still less.

Though large variations in the carbonic acid of the air

are not found, in spite of the enormous amount of impurity contributed by towns and cities, yet small variations are very common, even when the samples of air are collected at the same spot and within a few minutes of each other. There is also seasonal variation; it has been found that the carbonic acid in the air is lowest in the winter, highest in the autumn, but though it rises during the spring there is a diminution in the summer.

All chlorophyll-containing plants are capable of utilizing the carbonic acid of the atmosphere, storing up the carbon and liberating the oxygen. It is true this process is reversed at night, but as a means of keeping the atmospheric carbonic acid uniform it cannot be without value.

*Ammonia* is found in the air in minute traces, not as a normal constituent of the atmosphere, but as the result of the decomposition of nitrogenous products; it is found most largely in the air of manufacturing towns and cities, and diminishes after rain as the result of air washing.

*Watery Vapour* exists in the proportion of .8 to 1 per cent., but the amount existing in any sample of air depends upon the temperature. If the air has taken up as much vapour as it is possible to hold at that particular temperature, it is said to be saturated, but this is seldom the case. From 65 to 75 per cent. of saturation is supposed to be the best ratio for health.

*Organic and Suspended Matters* in air are really impurities, but are so commonly associated with it that it is impossible to separate them from a consideration of normal air.

The suspended organic matter consists of fungi, bacteria of many kinds, spores of lower organisms, vegetable debris, pollen of grasses, and in towns and cities minute portions of vegetable matter from dried horse fæces. Besides these, inorganic matter such as sand particles, soot, etc., are frequently present.

The significance of organisms in the atmosphere is not great. Moulds are less frequently found than bacteria, and there are fewer bacteria in the air on damp and still days,

than on dry and windy days. There are more organisms in the air during summer than during winter, and fewer after than before rain;—there are practically none at sea. There are none in the outside air to which any pathogenic significance can be attached, while the number present, about 25 to the cubic foot, is from ten to twenty times less than the air of inhabited places.

#### IMPURITIES IN AIR.

These are caused (1) By combustion of coal, gas, and artificial light. (2) By various offensive trades. (3) By decomposition of organic matters. (4) By respiration of men and animals.

They are removed or kept under control by certain natural processes. Diffusion and the action of the wind cause rapid and considerable dilution of noxious gases. Plants assist by utilizing carbonic acid and giving up oxygen. The oxygen of the air oxidizes organic compounds converting them into ammonia, nitric and nitrous acids. The air is washed by means of rain and impurities carried to the earth, where they are assimilated by plants and destroyed.

*Vitiation by Combustion.*—It was computed several years ago that not less than 822,000,000 cubic feet of carbonic acid passed daily into the atmosphere of London. This is largely derived from the combustion of coal, which gives off during the process of burning three times its weight of carbonic acid, and small quantities of carbonic oxide, sulphurous acid, and sulphuretted hydrogen. Besides these, about one per cent. is given off as soot and tarry products.

It is these latter, which owing to their weight are unable to ascend more than 600 feet, that give to London its peculiar winter fogs. The particles of moisture in the air are enveloped in a greasy hydrocarbonaceous covering which is impenetrable to light, and produce the peculiar yellow colour; while the sulphurous acid gas causes the irritation present in the eyes and bronchial membrane.

It was during a dense fog of this description some years ago, that such extraordinary mortality occurred among the cattle at the Islington Show.

Sulphurous acid is sometimes present to such an extent in the air of cities, as to render the rain acid, and even attack the softer kinds of stone used for building purposes ; it also destroys vegetation.

Coal-gas is a mixture of gases, principally hydrogen and hydrocarbons. The most poisonous constituent is carbonic oxide, of which between six and seven per cent. exists in well-made gas ; one per cent. in the air of respiration may cause death. A cubic foot of coal-gas yields about half a cubic foot of carbonic acid ; an average burner used in a stable burns five cubic feet of gas per hour, so the impurity in a stable arising from gas combustion can easily be calculated. One burner will impart to the atmosphere as much carbonic acid as a horse.

*Impurities from Offensive Trades.\**—These do not represent such an important class in veterinary as in human hygiene, for the reason that the presence of animals during the process of offensive trades is seldom necessary. Still horses are employed in mines, alkali works, copper-smelting factories, etc., and to an extent exposed to the organic vapours arising from glue-making, bone and blood boiling, slaughter-houses and knackeries.

The *air in mines* is generally saturated with moisture, and contains an excess of carbonic acid, depending on its depth ; as much as .2 per cent. is found in deep mines, with a reduction in the volume of oxygen. The temperature of the air is very uniform.

Vitiation of the air of mines takes place by the respiration of men and animals, gunpowder blasting, and the evolution of carbonic acid and marsh gas from the strata which are being worked. The atmosphere is full of dust, yet miners suffer the least mortality compared with other dust-inhaling occupations, and pit ponies, excluding acci-

\* Under the Public Health Act, 1875, no offensive trades can be established without the consent of the local authorities.

dents, practically have as long a life as those which work on the surface.\* It has been said that the relative innocuity of coal-dust, as compared with the dust of tin-mines, pottery manufacture, file-cutting, and knife-grinding, is due to the shape of the particles, which in coal-dust are free from sharp points and corners. It is also considered by some that coal-dust is inimical to the development of the bacillus of tuberculosis.

Pit ponies in hot dusty coal-mines are liable to become 'broken winded' after a few years' service, and many suffer from acute spasmodic asthma, which in time frequently terminates in broken wind. There is no such thing as 'miners' lung' amongst them, though many never come to the surface for years.

*Alkali and Acid Works.*—Hydrochloric acid gas is evolved from alkali works. Prior to legislation the effect of alkali works on herbage in their vicinity was to shrivel up and discolour the leaves and stems of trees and farm crops. Act of Parliament† now provides that 95 per cent. of the hydrochloric acid gases and vapours produced must be condensed. Only one-fifth grain per cubic foot is permitted by law to escape into the atmosphere. In the case of sulphuric acid works four grains per cubic foot is allowed to escape into the air.

From copper-smelting works arsenic, sulphurous acid and small quantities of copper are given off. Before legislation these produced among horses and cattle the so-called 'copper-smoke disease,' which showed itself by ossific deposits on the knees and hocks and general emaciation.

*Offensive Trades.*—The impurities due to the decomposition of organic matters in certain offensive trades have been classified by Dr. Ballard‡ as follows: (i.) The keeping of animals; (ii.) the slaughtering of animals; (iii., iv. and v.)

\* I am greatly indebted to Mr. W. Woods, F.R.C.V.S., Wigan, for much valuable information regarding pit ponies.

† Alkali, etc., Works Regulation Act.

‡ 'Effluvium Nuisances': Sixth, Seventh, and Eighth Report, Medical Officer Local Government Board.

branches of industry in which animal or vegetable or mineral substances are dealt with ; (vi.) branches of industry in which mixed substances are manipulated.

It is rather a satire on veterinary hygiene to find the keeping of animals classified as an 'offensive trade.'

It is to be feared that Dr. Ballard was well within the truth in his classification, though the object of the veterinary profession has been to prove that there is no necessity for the keeping of animals to be offensive, if the elementary laws of health are obeyed. Still in justice to the lower animals, which have no voice in the matter, it would be equally fair and truthful to classify the common lodging-house as an 'offensive trade,' and a far more serious one to the human community.

In Dr. Ballard's second group there is every room for improvement; the business of butcher and knacker may be offensive, particularly the latter, owing to the boiling operations in dealing with the bone, flesh, and fat, and the collection of putrefactive material on the premises. This and allied matters will receive special attention in a later chapter.

The third group comprises the trades in blood drying and boiling, soap and bone boiling, tallow-melting, glue-making, gut-scraping, and the business of the fellmonger and tanner, and are justly described as 'offensive trades.' The effluvium from these is very penetrating and sickly, but there is no evidence that beyond the injury to one's senses any harm results. It is equally clear that unpleasant as these trade operations sound, the nuisance resulting from them would be insignificant if proper cleanliness and destruction of noxious vapours were observed.

The fourth group consists of certain processes whereby vegetable material is manipulated, viz., the distillation of wood, manufacture of oxalic acid from sawdust, and distillation of vegetable oils, etc. In the fifth group is cement-making, brick-burning, gas manufacture, while the sixth group comprises the effluvium from chemical works, disposal of town refuse and manure-making. All these processes are offensive but not necessarily harmful to health.

*Air Impurities by Decomposition of Organic Matter.*—The air of sewers has always been regarded with great suspicion, but as a matter of fact exact enquiry shows that in sewers which are well constructed, the air is remarkably pure, and contains very little carbonic acid or sulphuretted hydrogen. Further the organisms present are much the same as in the outside air, both as to number and character, while the men working in well-ventilated sewers are no more unhealthy than the average of the population. These results are the outcome of scientific methods of drainage, and are a tribute to sanitary science.

When the air of sewers finds its way into inhabited places, which generally occurs through bad construction, the results appear to be very different; febrile disturbances, sore throat, bowel trouble, and in certain conditions of body—as in lying-in women—actual blood-poisoning. In animals there is evidence to show that this state of atmosphere reduces the normal resistance of the body to the invasion of specific diseases, and renders them not only more susceptible, but aggravates the type of case.

Sewage farms when properly managed are unobjectionable, but even badly managed farms have not been proved to be productive of disease. It would appear that danger from sewer gas and sewage emanations need only be looked for, when these find their way from ill constructed drains into a closed space, as into badly ventilated stables and houses.

In badly constructed sewers and drains the contents ferment and putrefy, with the disengagement of many gases, some of which are highly complex, and the majority offensive. There is evidence to show that sewer-gas in this condition may seriously affect those engaged in opening up and clearing out the drains, and there is no difficulty in understanding what such gases are capable of doing even diluted on entering buildings.

Emanations from manure-pits are not infrequently believed to be *healthy*, even by educated persons. Probably it is the ammonia that reminds them of the stimulating presence of 'smelling salts.'

Manure when placed in a pit undergoes decomposition and fermentation; it is during the latter process that the needful conversion into 'rotten' manure occurs which the farmer aims at producing. The formation of this is greatly accelerated by the presence of urine and fæces, in fact the straw by itself would be of very slight manurial value. As fermentation proceeds the temperature of the mass rises, and with it is given off ammonia which is probably the most valuable constituent of the manure.

The fermenting mass gives out free ammonia and carbonic acid to the air, and these may be detected even several yards from the pit. As the result of observations it was found that a pit should not be nearer to a stable than thirteen yards.

The air of marshes is impure from the presence of decomposing vegetable matter. Carbonic acid, marsh gas, and sulphuretted hydrogen are present, the latter sometimes in considerable quantity. The organic matter consists of various bacteria, fungi, algæ, and vegetable débris.

*Impurities by Respiration.*—Air is rendered impure by the respiration of men and animals, its carbonic acid and watery vapour are increased, its oxygen diminished, and a proportion of organic matter added to it. So long as respiration is occurring in the open air these impurities are got rid of as fast as they are formed, but in the air of buildings it is different, here they accumulate unless means are at hand for getting rid of them. The employment of such means is known as ventilation; ventilation and impurities by respiration are intimately mixed up, a proper understanding of the one is essential to the working of the other.

At each respiration—the number of which in repose varies with different animals—the air passing to the lungs contains 20·96 per cent. by volume of oxygen, and ·06 per cent. of carbonic acid. On its return from the lungs it is found to contain oxygen 16·96, carbonic acid 4·04, while the nitrogen in each case is unaffected. In other words,



the air in the lungs loses four or five per cent. of its oxygen, and gains three or four per cent. of carbonic acid, and these figures with slight differences appear to hold good for most domestic animals.

An average inspiration in the horse is 250 cubic inches ; if the composition of the ingoing and outgoing air be known, it is easy to calculate—once the volume of the air respired is ascertained—how much oxygen an animal uses up, and how much carbonic acid it produces in twenty-four hours. In the horse this has been fixed at 84 cubic feet of oxygen absorbed, and 72 cubic feet of carbonic acid produced in twenty-four hours, during a state of repose, but there is considerable variation, and the question is not susceptible of the accuracy these figures might imply.

During work both the absorption of oxygen and excretion of carbonic acid are very greatly increased, but this question does not seriously affect the question of ventilation, as the excess of both of these gases rapidly falls on the animal's return from work to the stable.

The proportion of oxygen absorbed to carbonic acid produced is not the same in all animals ; in the herbivora owing to their diet being rich in starch there may at times be nearly as much carbonic acid produced as oxygen absorbed, while in omnivora and especially carnivora, there is a marked increase in the oxygen absorbed over the carbonic acid produced.

In the herbivora there are also other gases which tend to produce air impurity, there is little doubt that marsh gas and hydrogen are given off by the lungs in both horses and cattle ; the amount is small, viz. under 200 cubic inches in twenty-four hours. These are derived from the intestinal canal, being absorbed by the bloodvessels and carried to the lungs. The gases formed in the intestinal canal are a considerable source of air impurity, some of these are most offensive owing to the putrefactive changes in the large intestine, carbonic acid and sulphuretted hydrogen predominate, marsh gas, nitrogen and hydrogen also exist in considerable quantity. The nature of the diet influences

the character of the gas; the most offensive is produced when the diet consists of material rich in nitrogen; marsh-gas predominates when the diet is largely hay.

From the decomposition of urea ammonia carbonate is formed, and from its peculiar penetrating odour is the first impurity detected on entering a badly kept stable.

Of all the impurities we have mentioned there is none so important from a hygienic point of view as carbonic acid. A considerable number of experiments have shown that the amount of this gas present in the air of either rooms or stables, is a direct measure of the degree of purity or impurity existing, further it is evidence of perfect or imperfect ventilation.

These results have been established beyond all doubt by the researches of the late Dr. de Chaumont on the air of barrack rooms, prisons and hospitals. He showed that as air impurity increased the carbonic acid increased, and that the amount of carbonic acid present was a measure of the purity of the air.

It is not the carbonic acid as such which is so important, even in the worst ventilated rooms and stables it rarely exceeds .3 per cent. No toxic effects from carbonic acid are produced unless the gas exists to the extent of five or ten per cent. in the mixture breathed.

The sole value of carbonic acid determination to the hygienist is the indication which it affords of the presence of organic matter in the air. It has been shown in the experiments above mentioned that these two are intimately related, and that up to a certain point one is a measure of the other. Before this question can be further dealt with, it will be desirable to consider what constitutes the organic matter in the air vitiated by the presence of men and animals.

*Respiratory Organic Matter.*—If a quantity of expired air be drawn through distilled water, the liquid has a peculiar odour imparted to it, and rapidly undergoes decomposition. If the air be condensed it can be shown that the organic substance contains nitrogen, can be precipitated by silver

nitrate, and decolourizes potassium permanganate. If water through which expired air has been drawn be distilled, free and albuminoid ammonia are obtained.

The smell of organic matter in inhabited places is peculiar and penetrating, it adheres to walls, and even after free perfilation of air the removal of smell is difficult, showing that the substance is not readily oxidized.

It was believed at one time that toxic effects could be produced by inoculation with organic matter in the form of a condensed liquid, but recent researches have not corroborated these observations.

The organic matter consists of particles of epithelium from the skin, hairs, fatty matters from the surface of the body, organic vapours the result of the decomposition of sweat and sebum, urine and fæces, but the nature of the substance resulting from these is quite unknown excepting, as just pointed out, it is very penetrating, nitrogenous, and putrefiable.

The feeling amongst hygienists at the present day is not to lay too much stress on the organic matter of badly ventilated rooms, as the chief cause of discomfort experienced by breathing air vitiated by respiration; but rather to attribute the symptoms of oppression, headache and sickness, experienced in hot and crowded rooms, to the deficiency of oxygen, and excess of carbonic acid, heat, and moisture, the latter being particularly harmful by checking the loss of heat from the skin.

The number of microbes present in vitiated air bears no relation to the amount of carbonic acid present; there are no microbes given off during expiration, and many of those contained in inspired air appear to be arrested very early in the respiratory tract, and do not reach the alveoli of the lungs.

In some extensive chemical and biological examinations of the air of buildings made at Dundee\* the observers in their biological work attached importance to the proportion

\* Carnelley, Haldane, and Anderson.

in which moulds as contrasted with bacteria were found in different atmospheres; they ascertained that bacteria predominate while moulds become fewer as the respiratory impurity increases. This is shown in the following table:—

	Amount of Air.	Moulds.	Bacteria.
	Cubic Inches.		
Open air ... ..	610	2	6
Houses of four or more rooms ... ..	610	4	85
Houses of two rooms ...	610	22	430
Houses of one room ...	610	12	580

These observers determined that the maximum number of micro-organisms in inhabited rooms should not exceed 560 per cubic foot of air.

#### DISEASES PRODUCED BY IMPURE AIR.

The foundation of Veterinary Hygiene was laid at the close of the 18th century, by a consideration of the diseases produced by impure air. One of the chief pioneers in the matter was Professor Coleman of the London Veterinary College, and the position he occupied in the world of science was such that attention was paid to his outcry.

He held the view that glanders could be produced in previously healthy horses, by exposing them to the vitiated air of a stable. In those days fresh air was considered not only unnecessary but pernicious, and every attempt was made to rigidly exclude it from stables, even the keyhole not being forgotten.

Coleman's view of the cause of glanders cannot be accepted in the present day, but whatever the pathologist may teach regarding micro-organisms, nothing can displace the fact that there are conditions of the body

which render an animal more susceptible of microbic infection, and there are others which establish a degree of resistance.

The vitiated air of stables reduces the resistance of the body and renders it more prone to infection, and this is the explanation of the triumphs of sanitary science in connection with the ventilation of stables and increased cubic space. Foul air and overcrowding are the prime factors in the production of disease, or as Parkes expressed it many years ago, 'disease and health are in the direct proportion of foul and pure air.'

The introduction of a system of ventilation into army stables by Coleman, saved the country hundreds of horses and thousands of pounds. The facts are chronicled by Sir Astley Cooper,\* who was most enthusiastic over the magnificent work carried out in the army by Coleman.

Nor were troubles among horses confined to the British forces, most if not all Continental armies at that time were similarly affected, but with one exception the records of the period are not available for study. The exception is France, who has published for years veterinary statistics of her army, and was able to compare her losses before the introduction of sanitary science, with those which occurred after a Commission of Military Veterinary Hygiene had pointed out where the errors lay, and how they could be avoided.

These statistical results have been rendered available through the labours of Dr. Balfour, F.R.S.† Prior to the year 1836, the French Cavalry lost from 180 to 197 per thousand per annum. An increase in the air space reduced the mortality during the next ten years to 68 per thousand, and at the present day it is 24 per thousand. With a reduction in deaths there was even a still larger reduction in admissions.

The following table shows the admissions for glanders

\* 'Life of Sir A. Cooper,' by Bransby Cooper.

† 'The Vital Statistics of Cavalry Horses': *Journal of the Statistical Society*, June, 1880.

and pneumonia from 1847-66, a period of nineteen years :

	1847-52. Ratio per 1,000.	1853-56. Ratio per 1,000.	1857-61. Ratio per 1,000.	1862-66. Ratio per 1,000.
Glanders ... ..	23·32	21·44	10·97	7·24
Inflammation of the lungs and pleura ...	104·7	110·6	45·8	3·59

This shows a reduction in admissions for glanders of 16 per thousand, while the admissions for pneumonia and pleurisy were reduced 101 per thousand.

The practical outcome of this sanitary work was the saving of £90,000 per annum in the purchase of horses. The saving, of course, was much greater than these figures represent, as they take no notice of the value of the horses left alive, which under the old system would have died.

Reynal\* states that when the old stables at the Alfort Veterinary School were enlarged and ventilated, the excessive mortality from pneumonia ceased, and wounds no longer took on the septic character which was previously so common.

A century ago, in the days of Coleman, the belief that pure air played an important part in the prevention of disease could be easily understood, since it was then very generally held that a vitiated atmosphere might lead to the generation in the system of noxious substances or 'humours' which were the immediate cause of the disease. Now, however, we are face to face with the fact that the very diseases associated with, or aggravated by, foul air are those which depend for their existence on a specific organism, and, it need hardly be said, the spontaneous origin of living matter is outside the pale of intelligent discussion. It is, however, quite easy to explain the beneficial

\* 'Veterinary Sanitary Science and Police': Dr. G. Fleming.

effects of a pure atmosphere otherwise than by supposing that it interferes with the spontaneous generation of pathogenic bacteria.

In considering the influence of impure air on the production of diseases now known to be caused by bacteria, it has to be borne in mind that the pathogenic microbes, in respect of their habit of life, fall into two great classes.

The first of these is the class of obligatory bacteria, which, whatever may have been their origin, are now unable to multiply except in the animal body. All the purely contagious diseases, that is to say, those that never originate spontaneously or independently of connection with an antecedent case, are caused by bacteria of this kind. Glanders, tuberculosis, and cattle plague are examples. The fact that the causal organisms of these purely contagious diseases are unable to multiply outside the animal body necessarily gives them a more or less restricted distribution; they are not ubiquitous, but confined to the neighbourhood of diseased animals or the places or premises where diseased animals have been kept.

The second great class of pathogenic microbes includes the so-called facultative bacteria, which, like the obligatory microbes, are able to multiply in the animal body and induce disease, but are also capable of multiplying and maintaining their existence in the outer world, in such media as soil, water, and decaying animal or vegetable matter. As might have been expected from their habit of life, the bacteria of this class have a very wide, and sometimes a practically ubiquitous distribution, and, also as might have been expected, the diseases which they induce are not necessarily contagious or infectious, but may arise sporadically. The majority of bacteria responsible for suppuration and other unhealthy processes arising in connection with wounds belong to this class, as do in all probability also some of the microbes which are the cause of 'colds,' bronchitis, and pneumonia. There are good reasons for believing that some of the bacteria which belong to this class are very frequently, if not constantly, present

in the digestive or respiratory tract of healthy animals, their presence there in moderate numbers being unattended by any untoward consequences, although in special circumstances they may be capable of inducing serious and even fatal disease.

Bearing these facts in mind, an attempt may be made to explain the beneficial effects of proper ventilation and a pure atmosphere in the prevention of bacterial diseases or in the amelioration of their effects.

It is obvious that none of the diseases caused by bacteria that are obligatory in their habit can be produced merely by causing an animal to inhale an impure atmosphere, and Coleman was therefore wrong when he held that glanders could be so produced in healthy horses. That is sufficiently attested by the distribution of glanders at the present day. In Great Britain glanders is now mainly confined to London and a few other large towns, and experience shows that in provincial towns and country places horses may remain permanently free from the disease although kept in badly ventilated and otherwise insanitary stables. The indispensable condition for an outbreak of glanders is the introduction of the agent of infection—the glanders bacillus, and that is nearly always effected by the agency of a horse that is already the subject of the disease.

But while it is thus certain that even the long-continued inhalation of impure air cannot produce glanders, it does not follow that the stable conditions which are necessary to insure a reasonably pure atmosphere are without effect in preventing glanders, or that an impure atmosphere is not favourable to the spread of the disease. On the contrary, it is evident that, given the existence of a glandered horse in a stable, an overcrowded condition of the inmates and a stagnant vitiated atmosphere may in two different ways facilitate the spread of the infection.

In the first place, these conditions will tend to make it more certain that the germs of the disease escaping from the already infected horse will be inhaled or otherwise



taken into the bodies of the healthy animals, for the more stagnant and impure the air of the stable the less will be the chance that the bacteria will be carried out of the building.

Secondly, the continued inhalation of an impure atmosphere will favour the progress of the disease in such animals as become affected, by inducing a state in which the natural defences of the animal body are greatly weakened. The researches of recent years have shown that by no means every horse that becomes infected with the bacillus of glanders thereafter develops extensive lesions or has its health seriously disturbed. Even in healthy subjects the bacilli may find admission to the body, and to a certain extent establish themselves there, but in vigorous states of the animal the natural defences suffice to hold the invading organisms in check, or even overcome these altogether. The agencies that tend to weaken the natural powers of defence against bacteria are impure air, under-feeding, and excessive work, and in all probability the most potent of these is the first.

In the second class of bacterial diseases, viz., those caused by germs that are capable of multiplying outside of the animal body, the effect of an impure atmosphere is probably even more malign. The bodies of both men and the lower animals must be constantly threatened with invasion by some of the bacteria which are almost ubiquitous, and which are on the border-line of being pathogenic even to those in robust health. Such organisms find their favourable opportunity when they encounter an individual whose natural defences have been weakened by insanitary conditions, prominent among which is the inhalation of a vitiated atmosphere.

One of the important, if not the most important, factors contributing to everyday immunity is pure air.

The term 'everyday' immunity is used to avoid clashing with the pathologist by employing the term natural immunity; and further, everyday immunity is temporary, it can hardly be otherwise, and depends on the individual

state of health from day to day. It is undesirable to visit a cholera patient while suffering from diarrhœa, or a diphtheria case when troubled with a sore throat, or to expose oneself to infection from any specific disease when 'below par'; under such circumstances the everyday immunity is likely to be found wanting.

The theory of Metchnikoff is certainly of inestimable value to the hygienist. It enables him to explain the defensive processes shown by animals living under sound hygienic laws, as compared with those living under insanitary conditions. It reduces the microbe to the level of the burglar, always attempting a favourable opportunity for entering a house, while the phagocytes represent an energetic police force, electric bells and good fastenings. The failure of any of these defensive processes to act means the success of the burglar.

The failure of the phagocytes of the respiratory or digestive tract to cope with the invading microbe means infection.

These views are not put forward by a pathologist, but only by a clinical observer, who may therefore lay too much stress on a well established experiment with one particular organism, but which appears to sum up the whole case of natural infection, and explains much in sanitation which is otherwise difficult to understand.

If an ox be inoculated with the spores of quarter-evil no results follow. If prior to inoculation the defences of the tissues at the seat of inoculation be destroyed by the injection of lactic acid, infection results; the lactic acid acts by repelling the phagocytes.

Pure air brings up a most excellent phagocyte, impure air destroys it.

If actual pathogenic organisms are present in the air of buildings, for example those of sheep-pox, cattle plague, tubercle, influenza, pleuro-pneumonia, etc., there is no difficulty in understanding the diseases may be air-borne. Anthrax in man is an excellent example in point; it is contracted mainly in the sorting of wool, or handling of hair of

animals which have been affected with the disease. The spores are disseminated through the air of the factory with the dust, and internal anthrax results. By sorting wool after damping it the spores and dust no longer arise and infection is controlled.

Pleuro-pneumonia is undoubtedly an air-borne disease, and one explanation of the rapid spread of cattle plague is through air infection.

A form of pneumonia in the horse which certainly looks infectious is very common on board a ship; it is nearly always fatal, runs a very rapid course, and if it is not attributable to a distinct microbe, then the foul air of the horse-decks must be held responsible.

Infectious pneumonia of horses on land is also described, which if it exists must be air-borne. Certainly the poison of influenza is carried in this way, and this disease is frequently associated with pneumonia.

The spread of tuberculosis in crowded cow-sheds is well recognised; it is not difficult to believe that many of these cases must be by air infection.

In the present state of our knowledge we hesitate to include that very fatal disease of calves, 'white scour,' as due to air poisoning, for there is evidence that infection may be principally by the digestive tract. One important practical point clearly stands out: if the cows calve in the open and away from the filthy surroundings of their houses, cases no longer occur. There may be quite another explanation of the observed result than on the theory of pure air, but the fact remains.

It is hopeless to attempt to treat chest cases in a badly ventilated stable; fresh air has never yet killed man or animal, it is the wind that kills.

Pneumonia may with advantage be treated in the open if there is nothing to choose between that and a badly ventilated place, and the same remark applies to all medical and surgical cases. In the human subject the open-air treatment of tuberculosis has been fully accepted.

In obstetric cases the value of pure air is undoubted, but both in this and the diseases mentioned above, it is impossible to separate impure air from unclean surroundings, or to accurately attach to each their respective share in the production of trouble ; it is evident if the surroundings are filthy the air must be impure.

## CHAPTER III

### VENTILATION

THE object of ventilation is to supply pure air to the lungs, to dilute and remove from the stable the products of respiration, and the effluvia arising from the fluid and solid excreta which have been evacuated.

To fulfil the conditions of ventilation it is necessary that *pure* air be supplied, it would not be ventilation if the incoming air were derived from a contaminated source.

It is usual to consider the subject of ventilation under three heads:—

- i. The amount of fresh air required.
- ii. The methods by which fresh air can be supplied.
- iii. The methods of examining whether ventilation be sufficient or not.

#### AMOUNT OF FRESH AIR REQUIRED.

The large herbivora take into their lungs during a condition of repose something less than 100 cubic feet of air per hour. At first sight it might appear that if this amount be known, the quantity of air required to be delivered for the purpose of ventilation could easily be ascertained.

The amount of air breathed by an animal is no guide to its requirements in the stable, for the reason that if only this quantity were supplied per hour, the proportion of impurity present in the air would be enormous.

The larger herbivora are capable of rendering 25 cubic feet of air absolutely irrespirable every hour; that is to say, if such a sample of air were collected experimentally,

any animal introduced into it would die in a few seconds.

In order that proper dilution of the air of buildings may be effected, about 150 times more air must be introduced per hour than actually passes through the animal's lungs. This appears difficult to understand, until it is explained that experimental inquiry has determined the limit of impurity of the air of inhabited places, and to prevent this amount of admissible impurity being exceeded, an enormous extra supply of fresh air is required.

The limit of impurity of inhabited rooms was fixed by the late Dr. de Chaumont as the result of numerous examinations of the air of buildings. He found that the amount of carbonic acid in the air of a room bore a relation to the degree of impurity present.

The actual amount of carbonic acid in itself was harmless, very much more could be breathed with impunity than could be found in the worst ventilated room or stable, but as a measure of the respiratory purity of the air, viz., as an index to the probable amount of organic matter present, it was found to give invaluable information.

We cannot have the air of a stable as pure as the outside air, it would require some millions of cubic feet per head per hour to produce this, but we can have the air of the stable sufficiently free from organic matter, to be unable to detect on entering it from the outside air any difference in the freshness of the two atmospheres.

This is the basis of de Chaumont's test; it has been applied over and over again in determining the sufficiency of the ventilation of stables, and is found equally applicable to them as to barrack rooms, hospitals, and prisons.

If on entering an inhabited building from the outside air, the sense of smell be at once recorded before it becomes blunted, a very fair idea of the amount of impurity may be obtained. If no sensible difference in smell can be determined, the air inside smelling as fresh as that outside, then the amount of organic matter is at its lowest point, and

such airs give on analysis  $\cdot 6$  per thousand of carbonic acid.

This  $\cdot 6$  per thousand of carbonic acid is made up as follows :—

- $\cdot 4$  per thousand of  $\text{CO}_2$  normally existing in the air.
- $\cdot 2$  per thousand due to respiratory impurity.

The maximum amount of respiratory impurity which can exist without impairing the *freshness* of the atmosphere is  $\cdot 2$  per thousand; if the air smells *rather close* the amount of respiratory impurity is  $\cdot 4$  per thousand; if the air is *close* the respiratory impurity is equal to  $\cdot 67$  per thousand; if *very close, disagreeable, and offensive* the carbonic acid present is equal to  $\cdot 9$  per thousand of respiratory impurity.

Beyond this degree of impurity it is not possible for the sense of smell to differentiate.

It is assumed that an air which does not differ in the sense of smell from the outside air is fit to breathe, but that no greater vitiation should be allowed. It is on this basis that  $\cdot 2$  per thousand of respiratory impurity has been fixed.

In recent years an attempt has been made to place the permissible respiratory impurity at a higher figure than that given by de Chaumont.

The explanation of this proposed change is based not only on an examination of the carbonic acid present, but also of the number of micro-organisms in the air, and the amount of oxygen required for the oxidation of organic matter. In this way it has been suggested that the amount of permissible respiratory impurity might be raised to  $\cdot 6$  or  $\cdot 9$  per thousand.

We do not feel justified in accepting this lower standard of purity for stables, where it will be remembered the impurity is not only of respiratory origin, but also derived from fæces and urine;  $\cdot 2$  parts of carbonic acid per thousand volumes of air is, therefore, adopted as the maximum amount of permissible organic impurity in the air of well ventilated stables.

From this can be calculated the amount of fresh air required by the large herbivora per hour, by using de Chaumont's equation  $\frac{e}{p} = d$

where  $e$  = the amount of carbonic acid in cubic feet exhaled per hour, viz., 3.

$p$  = the limit of permissible organic impurity per cubic foot, viz., .0002.

$d$  = the amount of fresh air required in cubic feet per hour.

$$\frac{3}{.0002} = 15,000 \text{ cubic feet per hour.}$$

That is to say, the large herbivora require 15,000 cubic feet of fresh air per hour, in order that the organic impurity may not exceed .2 per 1,000 of carbonic acid.

During work the amount of carbonic acid is greatly increased. It is only in mines that animals work in an enclosed space, and here the supply of fresh air per head should not fall below the above quantity, it is hardly practicable to ask for more, and being small ponies this amount must suffice.

The quantity of air required by the sick should be unlimited, if possible they should live almost in the open.

In calculating the amount of fresh air required the combustion of artificial lights must not be forgotten. Every cubic foot of coal gas produces .5 cubic feet of carbonic acid, and requires 500 cubic feet of air to properly dilute the products of combustion.

In badly ventilated stables the amount of watery vapour is increased. A horse gives off from the lungs and skin in a state of repose 6.4 lbs. water in 24 hours,\* and where the amount of fresh air introduced is insufficient to remove the excessive moisture, great discomfort and oppression exist. We have previously drawn attention to this fact, and repeat

\* This is according to the careful experiments of Grandcau; Colir places the figure much higher.



it here as bearing out the necessity for a large supply of pure air.

#### CUBIC SPACE.

Great stress has been laid on the importance of a large cubic space, as in the minds of some people there is an idea that by having a larger air space there is less necessity for ventilation. A large cubic space is a most desirable condition but not for the reason just mentioned.

The larger the air space the smaller the number of times per hour the air of that space has to be changed, and hence the less chance of draught. An example will explain the position. If two stables be taken, one of 600 feet the other of 1,500 feet contents, each of these must supply exactly the same amount of fresh air per hour to the occupant, viz. 15,000 cubic feet. But the air in the 600 feet stable will require to be changed a little more than twenty-five times an hour, whereas in the stable of 1,500 feet the air need only be changed ten times per hour.

Cubic space does not render ventilation less necessary, the stable of 1,500 feet without ventilation will become just as foul as the one of 600 feet, only it will take about double the time in the large stable to render the air as impure as in the small one. Once the air impurities are the same they both, irrespective of the difference in their capacity, must supply exactly the same amount of air; in other words, the value of cubic space soon vanishes unless regular ventilation is established.

The table on the next page, calculated from de Chaumont's equation, will enable this point to be understood.

The objection against small cubic space, as stated above, is that the air requires changing a large number of times in the hour to supply the amount necessary. It therefore has the drawback that such a stable would be draughty if properly ventilated; also, if the conditions which bring about natural ventilation become suspended or interfered with, the air contents of a small stable become more rapidly impure than those of a large one.

TABLE SHOWING THE CONTAMINATION OF THE AIR BY RESPIRATION IN DIFFERENT CUBIC SPACES, AND THE AMOUNT OF FRESH AIR REQUIRED TO DILUTE TO THE GIVEN STANDARD—VIZ., .2 PER 1,000.

Breathing Space for One Horse in Cubic Feet.	Ratio of CO <sub>2</sub> per 1,000 at the end of First Hour if there has been no Change of Air.	Amount of Air necessary during the First Hour.	Amount necessary every Hour after the First.
			Cubic Feet.
600	5.03	14,400	15,000
700	4.38	14,300	"
800	3.75	14,200	"
900	3.33	14,100	"
1,000	3.00	14,000	"
1,100	2.72	13,900	"
1,200	2.50	13,800	"
1,300	2.30	13,700	"
1,400	2.13	13,600	"
1,500	2.00	13,500	"
1,600	1.87	13,400	"
1,700	1.76	13,300	"
1,800	1.66	13,200	"
1,900	1.57	13,100	"
2,000	1.50	13,000	"
3,000	1.00	12,000	"

The cubic space best suited for animals is, therefore, readily arrived at; the whole thing hinges on the question of how many times the air space can be changed in an hour without producing a draught or causing the stables to become too cold.

In barrack-rooms it was found that under the ordinary conditions of our climate a change of air six times per hour was out of the question; five times could not be borne, and three times under the conditions of barrack-warming was all that could be attempted.

With regard to horses, it is well known that they are not so susceptible of draught and cold as men are, and certainly a change of six times in the hour can be and is borne by them with impunity; still, if it were decided that three times should be the limit in the number of changes of air in the hour, it would argue a capacity of 5,000 cubic feet

per head, an utterly impossible amount to give when the expense of stable construction is considered, but still the theoretical amount where expense is no objection, and only a small number of changes of air per hour are desired.

The cubic space fixed for army horses in the type of stable built during the last 30 years is 1,605 feet per head. This appears to agree with the cubic space allowed by some large companies and intelligent horse proprietors.

If 1,600 cubic feet be taken as representing the space allowed to horses living under the best possible conditions, the supply of 15,000 cubic feet of air can only be effected by the air of the stable being changed nine and a half times per hour.

Will a horse stand the air of the stable being changed nine times an hour in winter without suffering from draught?

There can be no doubt that, if properly fed, the natural coat not removed, or if removed a blanket given to take its place, horses will stand these changes with impunity. It practically means living in the open, for the air of the stable is changed about once every six minutes, but without the disadvantages of rain, snow, and wet ground to contend against, which living in the open entails.

Horses living under these conditions will not carry a fine glossy coat, but will be better able to withstand exposure to weather, such as working animals are at all times called upon to face, both in civil and military life.

Hot stables produce a fine glossy coat, economise the food so that the animals put on fat, but they also render them more susceptible to disease. Cold stables produce a heavy coat, there is not much tendency to the accumulation of fat, and the animals require more to eat owing to the call on the heat producing function. In return they are healthy, and the chance of chill from exposure is very small.

In the case of cattle it may be urged the amount of fresh air required would keep the temperature too low both for fattening and milk production. It is quite true the storing up of fat, and the constant drain on the mammary gland

are an abuse of a physiological function, and that special conditions may have in consequence to apply to such cases, but it has never yet been shown that unlimited fresh air in byres and cattle sheds either seriously retarded fattening or milk production, and there is no reason why they should if animals are liberally fed. Further, if a high temperature is desired it can always be obtained by artificial warming, without interfering with the supply of fresh air.

The advantage to be gained by the pure air method would be the practical eradication of tuberculosis among cattle.

Of the total cubic space the largest part should be made up in length and breadth and not in height; in human hygiene it has been proposed to disregard anything above twelve feet in height, for the reason that excessive height does not mean dilution of respiratory products, as these have a natural tendency to accumulate in the lower strata.

For veterinary requirements twelve feet with a closed roof must be regarded as an irreducible minimum, the remainder of the cubic contents to be made up of length and breadth. Where stables have an open roof, eleven feet to the spring of the roof is a suitable height.

Superficial area should be large both for the comfort of the animal, its safety, and the safety of the attendants; as a rule this matter is disregarded probably on the score of economy. For man  $\frac{1}{12}$  of the cubic space is desired as floor space;  $\frac{1}{16}$  is sufficient for the larger herbivora, and in this calculation is included not only the actual standing room of the stall, but the share of the passage behind.

The superficial area for the stall should be 70 feet, and this should be made up to a total of 100 square feet by including the share of the passage. For boxes the superficial area should be 200 feet.

The amount of cubic and superficial space allowed cattle is extremely small. The law insists the cow in a town

dairy shall have 800 cubic feet, but the superficial area is not laid down, and the animals are considered well off if they receive twenty-three square feet per head, this not including the share of the passage.

As a rule there are two cows in a stall each receiving the above superficial area ; it just affords standing room and but little more. The object of this cramping system is to keep the animals in such a fixed position that none of the excreta shall be lost to the drain which runs behind. Such deprivation of floor space should be regarded as a penal offence.

For country cow-houses no cubic space is fixed, and obviously none for fattening stock.

In town cow-houses the superficial area each animal should receive ought to be fixed at thirty-five feet as a minimum, exclusive of its share of passage, while the cubic space must depend upon the number of changes of air in the hour, but ought if possible to be 1,600 cubic feet, which is double the minimum fixed by law.

The law takes no notice of the country cow, the cubic space allotted her is whatever her owner can afford ; but it must be borne in mind her life is infinitely more natural than that of the town cow, she gets both fresh air and exercise, and it is only at night, or during inclement weather, that she is closed up in a place which is defective and insanitary.

Cattle fed for the purpose of food have a still more artificial existence, and if possible a more insanitary one, for the farmer has to make some form of profit during the life of the animal, and he does this through the manure. In consequence every effort is directed to saving and storing up this product, the most common method being to keep the cattle on about 90 square feet of space for weeks or months standing on their own excreta, which, with the straw allowed, by acting as a sponge absorbs all the valuable manurial material.

Under such a filthy system it is not surprising that no attention is given to cubic space, superficial area, or

ventilation, and it is fortunate for the animals their artificial life is only a matter of a few months.

It is quite useless to plead for better conditions, when men's pockets are touched with no corresponding return.\*

#### THE METHODS BY WHICH FRESH AIR CAN BE SUPPLIED.

*Natural Ventilation.*—Ventilation is of two kinds, natural and artificial; in veterinary hygiene it is the former which principally concerns us, and this is brought about through three agencies:—

1. The process of diffusion.
2. The action of the winds.
3. The difference in weight of masses of air of unequal temperature.

Natural ventilation can only be effectively employed when the type of building is such that the above forces can come into operation.

This type of building may be briefly described as one where the animals are arranged in two rows only, the heads turned to the outside walls. The width of the stable should not exceed thirty feet, and only two animals placed between opposite sources of air (Fig. 1). There should not be any rooms placed over the stable if this can possibly be avoided. The building blocks should not be arranged in the form of a square, but if this cannot be effected the interval between blocks should be twice the height of the nearest building. Such a stable only requires the introduction of doors and windows to render it the most effective instrument for natural ventilation.

The process of *Diffusion* is not a very active one in ventilation. Air may pass through a brick wall, but not if that wall be plastered or whitewashed within. Under

\* These matters will receive attention elsewhere, they are only introduced here as bearing on cubic and superficial space and ventilation.

the most favourable circumstances, viz., where the air is obtained through cracks and crannies in doors and windows, diffusion is a slow process, and by itself can never be trusted for the purpose of renovating vitiated air.

Diffusion merely causes the various gases present in a building to mix. Roscoe showed that carbonic acid experimentally evolved in a room was reduced to one-half in ninety minutes by this process. This is not sufficiently rapid for the purpose of ventilation, and further, it leaves the solid particles of the air quite unaffected.

*Winds* are the great power in natural ventilation; they mainly act by perflation, viz., setting masses of air in motion, and as a means of flushing and renewing the air,

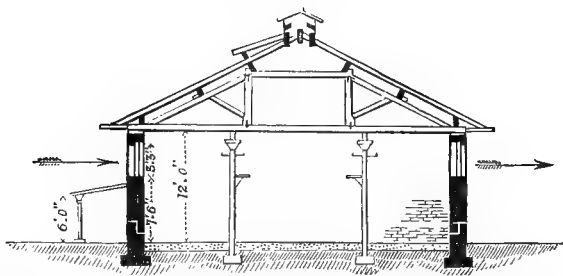

Fig. 1.—Transverse section of stable. Two horses are placed between opposite windows, heads to outer walls. The arrows indicate the direction of the wind.

there is no natural force comparable with them; for example, blowing at the rate of three miles an hour (which is little more than perceptible) through a ventilator one square foot in size, 15,840 cubic feet of air will pass per hour, the amount, in fact, demanded for the larger herbivora. Analyses of stable air show how rapidly by free perflation organic impurities may be removed; in half an hour the  $\text{CO}_2$  of respiration may be reduced from .6 to .1 per 1,000.

The chief difficulty in dealing with the wind as a ventilating agent is in regulating its velocity. With high velocities it causes a draught so that regulation of windows and ventilators becomes necessary. The opposite extreme may

also be met, viz., stagnant air, though such a thing is rarely met with in Great Britain, where the average annual movement is from six to twelve miles an hour.

Besides its perflating power, the wind also produces an aspirating effect. This is caused by currents setting in at right angles to the path of the moving body, to replace the partial vacuum produced. The draught up a chimney is one example of this, and advantage has been taken of its aspirating effect, to cause the wind to produce movements of air in a tube for the purpose of ventilation.

It is the aspirating action of the wind which is utilized in the numerous patterns of cowl which are employed either for chimney or ventilating purposes.

*Masses of air of unequal temperature* are not a satisfactory method of ventilation in veterinary hygiene, as the heated air inside a building only arises from the bodies of the animals, and is therefore vitiated. Heated air expands and by so doing partly escapes, an attempt to restore the balance is met by colder air coming in; and so the process is continued, cool air entering and warm air escaping. The greater the difference between the temperature of the external and internal airs, the greater the movement; the less the difference the smaller the action.

It is quite possible to roughly determine the purity of stable air with the thermometer. In the depth of winter a difference of five degrees between the inside and outside airs may be associated with considerable impurity, while one degree difference may be indicative of great purity. The explanation lies in the fact that the heated air is derived from the bodies of the animals present. As a means of natural ventilation this process of unequal weights of air does not occupy a strong position; with artificial ventilation where heating is employed, it may be of the utmost value.

In summarising the three forces acting in natural ventilation there is no difficulty in recognising the wind as the chief agent, next comes diffusion, while columns of air of



unequal temperature, depending as they do on the air being heated by the bodies of animals occupying the building, are not only irregular but undesirable. On the other hand, as a means of artificial ventilation it may be made a most perfect system if expense be no object, and we may here conveniently consider this question.

*Artificial Ventilation.*—If the air entering a building can be warmed and the place maintained at a temperature of 60° Fahr., the greatest opponent of fresh air can no longer have a valid reason left for closing an aperture.

The maintenance of stables at a temperature of 60° Fahr. through the heat given off from the bodies of animals, as is at present the case, is hygienically bad. If it be considered necessary to bring up horses and cattle as tender hothouse plants, then to live at 60° in an air saturated with moisture is the best means of securing it. If it be recognised that this heated foul and moist atmosphere is unhealthy, and yet a temperature of 60° is desired, it can only be obtained by artificial ventilation, the simplest system probably being that shown in Fig. 2.

A bracket containing a metal tube, bent in several directions so as to give it a large surface, is placed opposite an inlet. Inside the tube is a Bunsen burner, the products of combustion being carried outside the stable.

The heat travels through the whole length of the pipe,

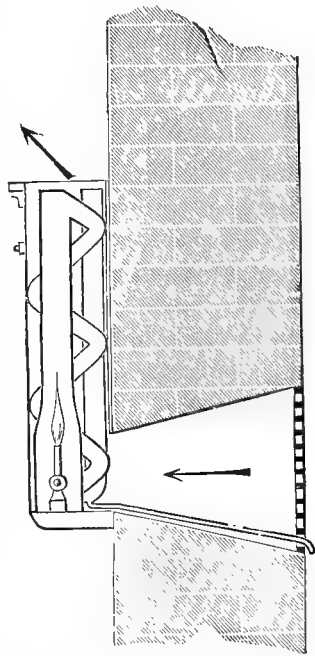

Fig. 2.—Boyle's system for supplying fresh and warmed air to stables.

and the air passing over it has its temperature raised. The inventors claim the incoming air can be raised from  $30^{\circ}$  to  $130^{\circ}$  Fahr. The cost of gas in raising the temperature sixty degrees is less than one farthing an hour, and for this sum 18,000 cubic feet of air can be heated.

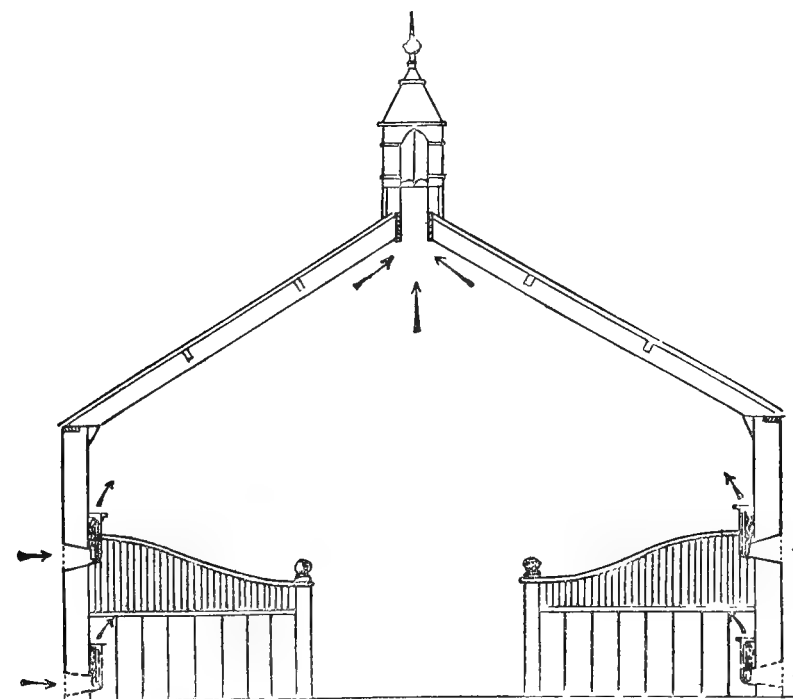

Fig. 3.—Section of a stable heated artificially by means of Boyle's gas-bracket. On the ridge may be seen the exhaust 'air-pump' of the same firm.

Gas may also be employed for extracting impure air by being placed under suitable tubes for this purpose. One cubic foot of gas will extract 3,000 cubic feet of air, and as an ordinary burner uses five cubic feet per hour 15,000 cubic feet per hour may in this way be got rid of.

Gas is not always available, but we are not limited to this, there are other methods by which stables and cow-

houses can be warmed, viz., by carefully constructed stoves, or by hot-water pipes. There is no difficulty in carrying these methods out, and low-pressure hot-water pipes are absolutely free from danger.

To raise the temperature of the air to 65° Fahr., it is calculated that there should be twelve feet of low-pressure piping for every 1,000 cubic feet of space.

The whole question of heating hinges upon cost, which fortunately renders it prohibitive for industrial stables, but adds very little to the extravagance bestowed on some high-class stables of the present day; for cow-houses it is the only solution of the problem of ventilation and warm air.

#### *Inlets and Outlets.*

From what has been said, it will readily be understood that the inlets and outlets employed in natural ventilation consist essentially of doors and windows. These only exist in sufficient number and good position, when they have been intentionally designed with this object in the construction of the building. Most stables and habitations for animals are built without any reference to the requirements of sanitary science, fresh air and sunlight being regarded either as unnecessary or prejudicial.

Ventilators are of two kinds, inlet and outlet; the terms need no definition. With artificial ventilation the function as inlet or outlet is performed with fair regularity, but in natural ventilation the term inlet and outlet is more of theoretical than practical interest, for the reason that as natural ventilation depends almost entirely on the wind, the same opening may be an inlet one minute and an outlet the next.

What is aimed at is to have inlets in the wall and outlets in the roof, but we shall have to show that openings in the wall are always inlets on the windward side and outlets on the lee side, while openings in the roof, as in ridge or louvre ventilation, may be the same. It is not possible,

therefore, under natural ventilation to point out any openings as being always inlets or always outlets, though we shall presently have to qualify this statement somewhat, in dealing with the mechanical contrivances known as cowls. With this caution we shall continue to employ as a matter of convenience the terms inlet and outlet as applied to ventilators.

Inlets and outlets are of various kinds, viz. doors, windows, tubes surmounted by downcast or upcast cowls, perforated bricks, openings in the ridge of the roof with or without louvres, and holes placed in the wall.

*Doors* need no special consideration, the tendency is

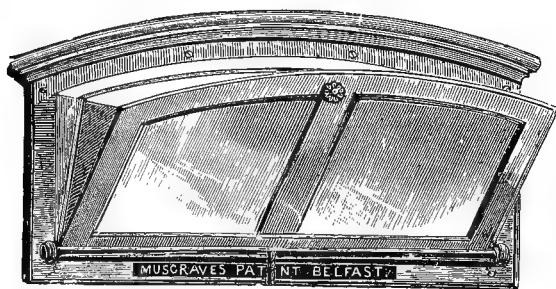

Fig. 4.—Sheringham ventilating window (Musgrave).

always to shut them, and in calculating the air requirements they must be left out of question as they will certainly be closed at night, at which time the greatest air impurity exists. As a means of flushing the stable during the day, drying the floor, and thoroughly perflating the building, they have no equal if they exist in sufficient number for the size of the structure, and especially if they are placed on opposite sides of the stable.

*Windows* as the chief means of natural ventilation require some detailed consideration. In most modern stables they are arranged on the principle of a Sheringham valve (Fig. 4), by which the air is directed upwards in order to prevent a draught.

This valved window is placed above the horse's head, and is a useful addition to the lighting of the stable; if the latter be defective in light Fig. 5 may be employed. For industrial stables the ventilating iron framed window employed in Army stables may be used; this is 3 feet 3 inches high, 2 feet 6 $\frac{3}{4}$  inches wide, and the upper part, when swung inwards, is fully open at 19 inches, thus affording a ventilating area of a little over four square feet.

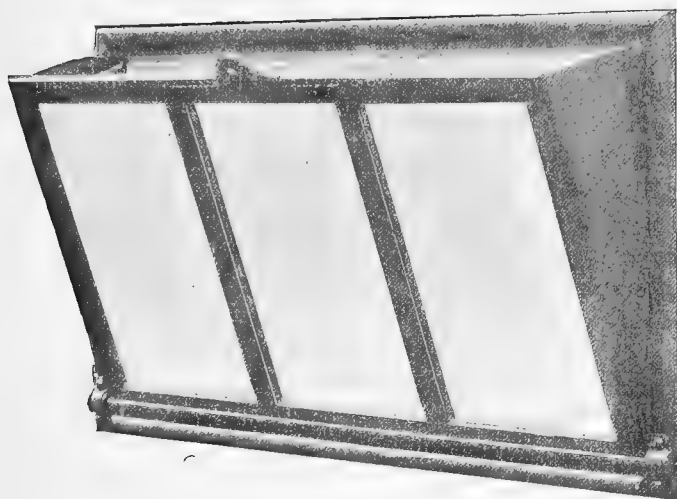

Fig. 5.—Sheringham ventilating window (Musgrave).

All this class of window can be regulated to any size, and as a ventilating medium cannot be surpassed.

*The direction taken by air currents* under the system of natural ventilation has been made a subject of special study, and as the matter is of the utmost importance to a clear understanding of the system of ventilation by windows, no excuse will be made for dealing with it somewhat in detail.

The type of stable now being described is the one with two horses only between opposite sources of air, with a

window in the wall over the head of each animal, the windows being pivoted and not of the Sheringham valve type just described.\*

With windows fully open to windward, opposite ones closed, and ridge open (Fig. 6) the air rushes in, carries all before it, then spreads out fan-shape and falls to the ground. If the incoming current be powerful it may be measured 18 feet from the point of entry, but as a rule 6 feet to 8 feet is the distance at which it can be felt, the velocity rapidly and suddenly decreasing on meeting with the large body of air already in the stable.

The tendency of the incoming air is to spread and fall

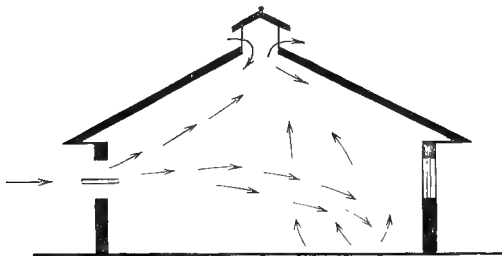

Fig. 6.—Direction taken by air currents with the windows open to windward.

fan-shaped to the ground, and in so doing it drives before it the air previously there, until this is forced upwards and escapes by the ridge on the leeward side.

If the incoming current be powerful, part of it may escape at the ridge on the leeward side without mixing with the lower stratum of air, while the windward side of the ridge may act as an inlet.

No currents can be detected under the open window, the velocity with which they enter carries them practically clear of the horse standing there.

When opposite windows are open (Fig. 7) the air rushes

\* At the time these observations were made, no building fitted with Sheringham windows was available, but this does not affect the general principles here described.

in on the windward side, behaving much as just described, striking the ground and driving the upper stratum of air through the leeward side of the ridge. If the incoming velocity is very great the air may traverse the stable,

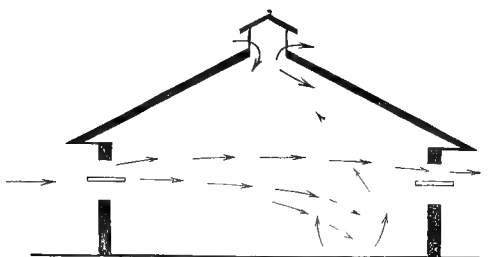

Fig. 7.—Direction taken by air currents with windward and leeward windows open.

and pass out at the opposite window without mixing (Fig 7.)

A double incoming current from opposite windows may frequently though often momentarily be detected (Fig. 8); the two meet in the centre of the stable, and the ridge acts as the outlet. The double current lasts but a short time, and

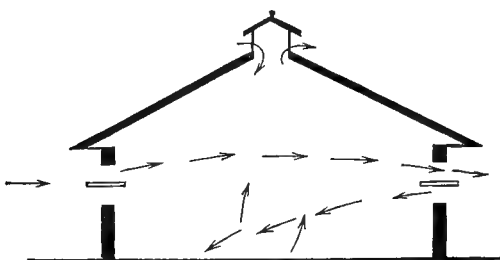

Fig. 8.—Double current from opposite windows.

is replaced by the single inlet and opposite outlet, which in due time is again disturbed.

When opposite windows are *half* open (Fig. 9), and thus resemble Sheringham windows in construction, the chief difference observable is the height to which the incoming

air is thrown before it reaches the ground. The window on the lee side is the principal outlet, but the air does not escape from it until the incoming air is well mixed. If, on the other hand, the lee window be fully open while that on the windward side be only half open, the tendency of the

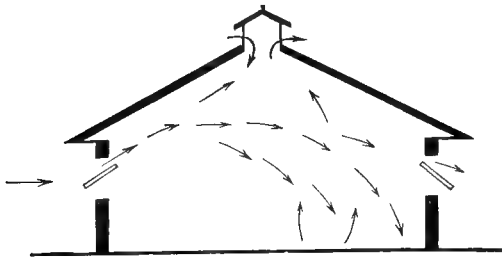

Fig. 9.—Direction taken by air currents when opposite windows are half open.

incoming air is to escape direct at the lee window without proper mixing.

When the windward window is half open and the lee window closed, the incoming current is directed towards the ceiling, descending fan-shaped and well mixing with

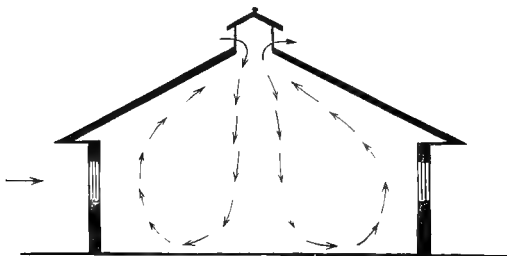

Fig. 10.—Direction taken by air currents when all doors and windows are closed.

the stable air; the ridge under these conditions acts as a fairly regular outlet.

If all the windows be closed and the doors only left open, the ridge acts as a fairly regular outlet. With doors and windows shut the ridge is an inlet on the windward side and an outlet on the lee side (Fig. 10.)



In all cases the introduction of stall divisions interferes materially with the thorough perfation of air ; the incoming current strikes the stall division and goes over it. In this light stall divisions can only be regarded as an objection from a sanitary point of view, so that the introduction of bails in industrial and military stables has something more than economy to recommend it.

Ventilation by windows in the type of stable described is the most perfect that can be produced, though the open ridge as an outlet leaves something to be desired ; short exhaust tubes of good diameter with fixed extraction cowl, would probably be preferable for small stables, and prevent down draught.



Fig. 11.—Simple extraction cowl (Parkes).

*Tubes, Air-Shafts and Cowls.*—The most simple form of exhaust or extraction tube is that seen in Fig. 11. Around the top of the tube is a collar or flange sloping downwards ; covering the tube, but at some height above it, is a conical cap supported on uprights. Air currents impinge on the flange, and passing across the mouth of the tube produce an aspiratory effect. If the structural mechanism of this cowl be reversed, an inlet or downcast tube is produced (Fig. 12.)



Fig. 12.—Inlet cowl (Parkes).

Cowls for covering tubes are of many kinds, the most familiar perhaps being the lobster back made with a vane, either to open towards the wind if intended as an inlet, or away from it if an outlet.

But there is a serious disadvantage attached to all such cowls, they depend on their mechanism keeping in perfect order, and experience shows they are very liable to derangement. A fixed cowl is best, and of these there are many in the market. Fig. 13 is a Boyle extractor, the mechanism of which may be seen in section, Fig. 14. 'A' indicates the opening into which the wind passes, and impinges upon the deeply-

curved bell-mouth arrangement 'B,' in which a large body of air is collected and forced into the narrow annular space 'C,' at which point, owing to the compression of the air, which cannot otherwise escape or free itself, it attains a greatly accelerated velocity, and, in passing over the slip 'D,' creates an induced current, exhausting the air with rapidity from the central chamber 'E.'

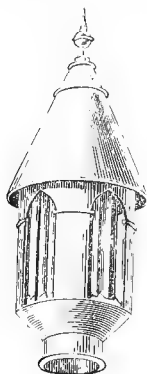

Fig. 13.—Boyle's air-pump extractor.

The foul air immediately rushes up the shaft to supply the place of the air extracted, and is in its turn drawn off, thus creating a continuous upward current in the shaft connected with the place being ventilated. An exhaust cowl constructed on these principles may also be employed in ship ventilation.

The extracting power of this and similar contrivances lies in the size of the head; the head should always be about double the diameter of the tube to which it is connected.

Tubes or shafts may be used either as inlets or outlets. The golden rule is never to employ them if they can be avoided, and never to use a long one if a short will serve the same purpose.

Air passing along a tube suffers loss from friction, and in consequence its velocity is diminished; the narrower the tube the greater the friction. Angles or bends in tubes are more important causes of loss; for example, if a current be passing along a tube at a velocity of 10 feet per second, on meeting with a right angle its velocity is reduced to 5 feet per second, a second right angle will reduce it to  $2\frac{1}{2}$  feet per second.

Thus a right angle diminishes the velocity by half, this is

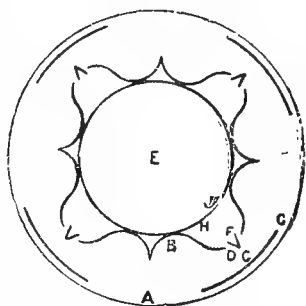

Fig. 14.—Plan of Boyle's air-pump.

explained by Fig. 15, the star indicates where the current strikes, the impact destroying half its velocity. Any bend in an inlet or outlet tube must be a curve as in Fig. 16.

Apart from these considerations dust and dirt accumulate in tubes, in spite of wire gauze and other contrivances being placed over the opening. If of great length these shafts cannot be cleaned out, and should they possess right angled bends it is impossible to deal with them.

The shape of a tube is important; a circular shaft gives the largest area within the least circumference. Further, there is less friction in a circular than in a square tube.

As an inlet for large stables a shaft must be absolutely condemned, it can never be made sufficiently large to supply the requirements. In a private stable, on the

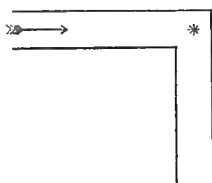

Fig. 15.

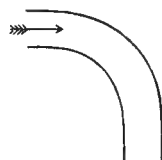

Fig. 16.

contrary, it may be made a useful inlet for a small number of horses, where more perfect means do not exist.

If long tubes are used as extraction shafts the air in them becomes rapidly cooled, and instead of ascending it falls unless a good exhaust cowl exists. Further, the cooling of the tube may cause a double current to be established, warm air passing up one side and cool air down the other.

The practical deductions are obvious, extraction tubes cannot be too short, nor can they be kept too warm. If they happen to be carried near a chimney it will greatly assist; if in a loft they may be surrounded by forage, and thus the cooling influence of the outside air avoided.

A tube with a central division has been made to act both as an inlet and outlet (Fig. 17). There is an upward current on one side and a downward on the other.

Muir designed a shaft with four partitions, the external

opening being protected by a louvred cover. Such tubes may be fixed in the roof of the stable, but are far too uncertain in their action.

Another form of divided tube is McKinnell's (Fig. 18). This consists of two circular tubes, one placed within the other. The area of the outer tube should be larger than that of the inner, as there is double friction to be overcome.

The inner tube is the outlet, the air in it being kept warmer by the outer tube; outside the building it is carried higher than the latter, and surrounded by a hood, though

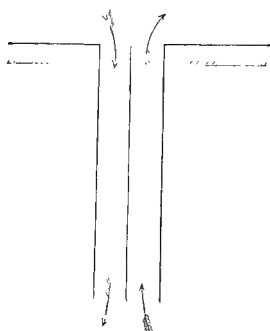

Fig. 17.—Divided tube  
(Parkes).

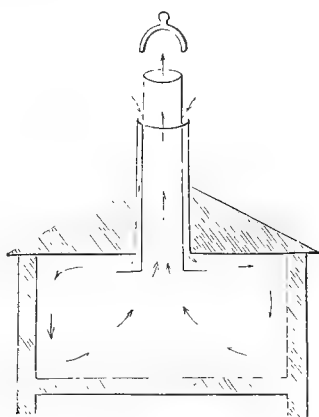

Fig. 18.—McKinnell's tube  
(Parkes).

a cowl would be preferable. Where the inlet tube enters the room is a flange to prevent down-draught and distribute the air.

When the doors of the stable are open both inner and outer tubes become outlets, when the door is closed the double action of the tube is again established.

As a means of ventilation for a small stable it is unobjectionable.

Tobin's tubes (Fig. 19) are sometimes used as inlets in the ventilation of stables. The tube, which is about six feet high, is placed against the inside wall, while externally it is carried through the wall at the ground level. The air

entering the tube is directed upwards towards the ceiling, and gradually mixes with the air of the stable without causing a draught.

These tubes externally require to be protected from vermin, while their interior, it must be borne in mind, requires to be periodically cleaned. They are not recommended for stable purposes if any other plan is available.

A ventilating pillar somewhat on the principle of a Tobin's tube is sometimes employed in stables (Fig. 20). It embodies the objection most tubes possess.

Perforated bricks may be used as a useful inlet under some conditions. They are made in two sizes giving respectively  $11\frac{1}{2}$  square inches and 24 square inches of ventilating surface. A form of air-brick with conical holes, the small hole being turned to the outside air, may also be usefully employed; they are known as Ellison's (Fig. 19). The effect of the conical holes is to break the current and distribute the air.

Air-bricks can only be a supplemental means of ventilation, when that afforded by windows is insufficient owing to structural defects in the building. In stable hygiene the drying and sweetening of the floor is a matter of the utmost importance, and this may be assisted by ventilating bricks being placed near the ground, especially where the other means of ventilation are defective.

In stables with bails if there be good window and door ventilation, ground inlets or air-bricks for drying the floor are not required.

It is usual to regard the ridge ventilator as an outlet; as a matter of fact it is both an outlet and inlet as previously described. The boards forming the louvre must be wide

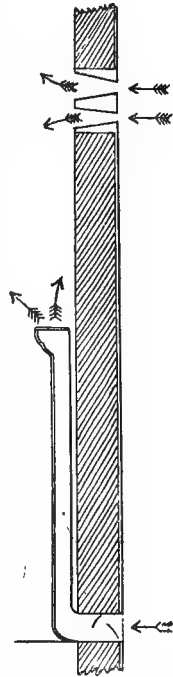

Fig. 19. — Tobin's tube. In the wall above may be seen Ellison's Air-Brick.

enough and close enough to prevent rain drifting through; the angle these boards are placed at is of far less importance than their width.

As a means of ventilation the ridge is excellent; as it is desirable extraction should always take place at the roof, fixed cowls on the ridge would be better than louvre boards for small but not for large stables, as with the latter a sufficient number could not be employed.

The strong argument in favour of the open ridge with

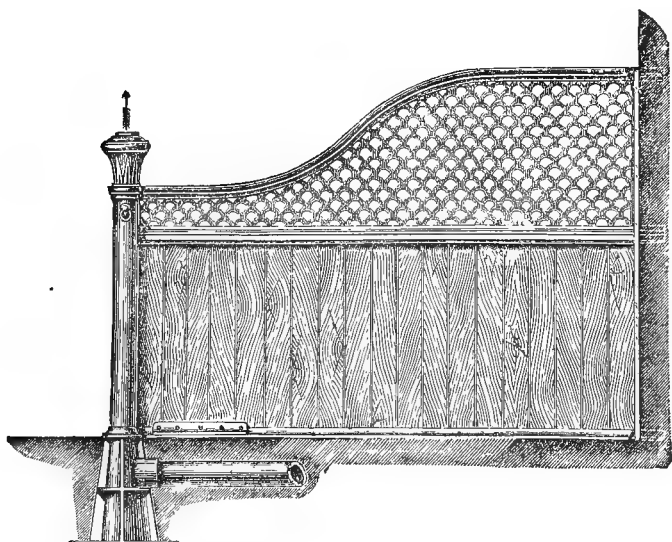

Fig. 20.—Ventilating stable pillar on the principle of a Tobin's tube.

louvre boards is that it cannot be closed, and this in the case of large stables may be a great advantage, for even if all doors and windows are shut the ridge both admits and discharges air (Fig. 10, p. 72), and this it could not do if only fixed extraction cowls existed.

*The relative size of inlets and outlets* has been much discussed. It has been said that the outgoing air being lighter, and thus occupying more space, the outlets should be larger than the inlets; as a cubic foot of air only expands  $\frac{1}{17}$  of its bulk for 30° Fahr., it is obvious

that there need be no difference in the size of the two openings.

In calculating the size of inlets for natural ventilation no other force than that of the wind need be regarded. The size of the inlet must depend upon the velocity of the incoming air.

One square foot of inlet with a calm wind, viz., a mean velocity of three miles an hour, will supply a horse with the full amount of air required. But there are many conditions which render it undesirable to limit ourselves to inlet openings of one square foot, for example, one window has frequently to be an inlet for two horses or even more, it is, therefore, safer to say the ventilating inlet area shall

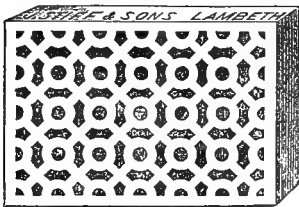

Fig. 21.



Fig. 22.

## Air-bricks.

not be less than three square feet per head, and shall be under control. This latter, as pointed out previously, can be effected with a Sheringham window.

Under some circumstances, especially in private stables, it may be considered desirable that some portion of the ventilating area should not be under control, in this case air-bricks near the ground and under the eaves may be employed.

If the question of air-currents in the type of stable described on p. 63 has been made clear, it is evident that each inlet window must supply air to two horses, viz., those opposite to each other on either side of the stable. If only one row of horses exist then the calculation of the size of inlet is made for one horse only, provided each animal has a window to itself.

There are so many different types of stable that it is only possible to indicate general principles.

The following table should be useful in determining the size of inlets depending on the velocity of the wind. The scale of wind is known as Beaufort scale.

Description of Wind.	Mean Velocity in Miles per Hour.	Size of Inlet to admit 15,000 Cubic Feet of Air per Hour.
		Square Foot.
Calm ... ..	3	1
Light air ... ..	8	.4
Light breeze ... ..	13	.2
Moderate breeze ... ..	23	} .12
Fresh breeze ... ..	28	

Having judged the velocity of the wind, knowing the number of animals in the stable, and the number and size of the ventilators, it is easy to calculate the width there should be open to supply 15,000 cubic feet of air per head.

The rule is, multiply the number of animals to be supplied with air, by the size of the inlet corresponding to the judged velocity of the wind. Divide this by the number of ventilators on the inlet side of the building, and the result is the size in square feet which each inlet should be open.

*Example.*—How wide open should be the windows or ventilators of a stable under the following conditions?

- The velocity of the wind is 13 miles per hour.
- The number of horses in the stable, 12.
- The number of windows on the inlet side, 6.
- The width of each window, 2 feet 6 inches.

In the table opposite to 13 miles is .2; therefore,

$$\frac{12}{.2} = \text{number of horses.}$$

$$\text{Number of windows} = 6 \left| \frac{2.4}{.4} \right.$$

$$\frac{2.4}{.4} = \text{number of square feet for each window} \times 144 = 57.6 \text{ inches.}$$



The width of each window is 2 feet 6 inches = 30 inches.

Therefore  $57.6 \div 30 = 1.9$ . Or, in other words, each window or ventilator must be opened 2 inches to admit, at a velocity of 13 miles per hour, 15,000 cubic feet of air per head.

This calculation, then, shows the size to which the *inlet* windows should be opened; but it is obvious, from what has been previously stated, that the outlet windows should be opened the same width, not only that they may act as outlets for an equal bulk of air which is admitted by the inlets, but for the reason that the wind may shift round, and they must then act as inlets.

In calculating the width which ventilators should be open when both sides of the stable are occupied by horses, it is necessary to remember that the inlet windows must be calculated for supplying two rows of horses, viz., those under the windows, and those on the opposite side of the stable.

No difficulty should be felt in estimating approximately the velocity of the wind from the table given above. The average velocity of the wind in Great Britain is from six to twelve miles per hour.

The leading principles to guide us in the natural ventilation of stables are:—

1. The wind is the great ventilating agent, in order that it may act to full advantage window should be opposite to window, and door to door.

2. The distance between opposite doors and windows should not be more than 30 feet.

3. In order that effective ventilation may occur only two horses should be placed between opposite sources of air, as in Fig. 23; the transverse arrangement of horses in stables, where several are placed between opposite sources of air, is bad, see Fig. 24.

4. Stables with open roof as in Fig. 23 are easily ventilated, those with living-rooms above as in Fig. 24 can never be effectively ventilated.

5. In natural ventilation any opening may be an inlet or

outlet; the direction of the air-current through an opening depends on the direction of the wind. It is desirable,

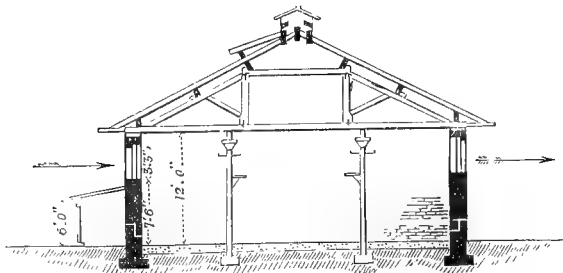

Fig. 23.—Transverse section of stable. Two horses are placed between opposite windows, heads to outer walls. The arrows indicate the direction of the wind.

however, to work on the principle of inlets in the wall and outlets in the roof.

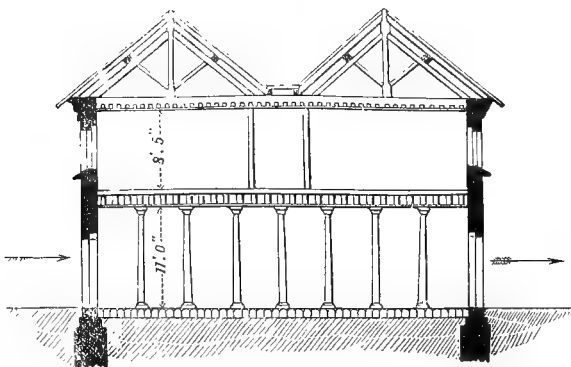

Fig. 24.—Transverse section of stable. Eight horses are placed between opposite windows, with their heads to dividing walls. The arrows indicate the direction of the wind.

6. Tubes or shafts either as inlets or outlets are generally to be avoided.

#### *Mechanical Ventilation.*

This may be defined as the method by which air is extracted from or propelled into buildings by means of pumps or fans. It obviously is not a system to employ

excepting under very special conditions, both from its cost and the probability of a break-down; yet when horses are stabled underground, or in tunnel-shaped structures with no openings above, or on board a ship, it may prove a very useful system.

Its convenience of adoption largely depends upon what motive power is available. On board a ship this should not be difficult to arrange either by steam or electricity, but on shore it is likely that special apparatus may have to be supplied for this system of ventilation, and this adds greatly to the expense.

Fans of different forms have been used for many years for propelling air, in mines. Since the introduction of electricity they have been commonly employed in crowded places either for propelling or extracting, and a considerable quantity of air can be delivered or removed by these means.

A well-known form of fan is that seen in Fig. 25, known as the Blackman Air-Propeller. Depending on its size, from 6,000 to 12,000 cubic feet of air per minute can be delivered for one horse-power expended in driving it.

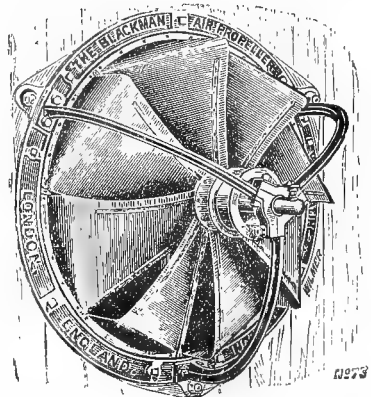

Fig. 25.—Blackman Air-Propeller.

on its size, from 6,000 to 12,000 cubic feet of air per minute can be delivered for one horse-power expended in driving it.

Ventilation by propulsion is considered more satisfactory than that by extraction; but there is no necessity to be limited to one system. Both may be advantageously combined, and with such natural ventilation as may be available, it should be possible to keep the air of a place, even that of a horse-ship, comparatively pure. This subject will be touched on again in dealing with marine hygiene, when reference will also be made to extraction of air by means of a steam jet.

## METHODS OF EXAMINING THE SUFFICIENCY OF VENTILATION.

The sufficiency of ventilation is ascertained by calculating the cubic and superficial space available per head, the amount of fresh air supplied, and the composition from a chemical and biological standpoint of the air of the building when fully occupied.

*Measurement of cubic contents* is obtained by multiplying the length, breadth, and height of the building into each other.\* Where roofs are angular, these are calculated separately and added. As a rule no important deductions have to be made for projections and fittings, but supporting pillars, if large, should certainly be deducted from the calculated air-space, and so should the space occupied by the bodies of the animals; for the large herbivora deduct from 18 to 20 cubic feet per head.

The *cubic contents of a cylinder* are obtained by multiplying the area by the height. The *area of a circle* is obtained by multiplying twice the diameter by  $\cdot7854$ . These rules enable the contents of stable pillars to be ascertained.

The *area of a rectangle* is obtained by multiplying two sides which are perpendicular to each other. This rule gives the superficial area of a stall or stable.

The *area of a triangle* is obtained by multiplying the height by half the base, or the base by half the height. The application of this rule enables the contents of an angular roof to be calculated.

Here is an example of the above measurements:—

A stable for ten horses, with an angular roof, has the following measurements—

Breadth ...	...	...	...	...	Feet.
Length ...	...	...	...	...	15
Height to spring of roof	...	...	...	...	60
Height of angular roof	...	...	...	...	15
				...	5

Supporting pillars, 8; diameter, 6 inches; height, 15 feet.

---

\* In measuring buildings it considerably simplifies the calculations if the measurements are made in feet and decimal parts of a foot, and not in feet and inches. For the decimal parts of a foot, see Appendix.

Ascertain the available cubic contents after making the usual deductions.

The first thing is to estimate the body of the building; this is

$$15 \times 60 \times 15 = 13,500 \text{ cubic feet.}$$

The contents of the angular roof are next ascertained.

In the figure which represents the roof under consideration, A B is the base, which we know from the breadth of the building to be 15

feet, and C is the vertical angle; the distance from C to the base, shown by the dotted line, is the

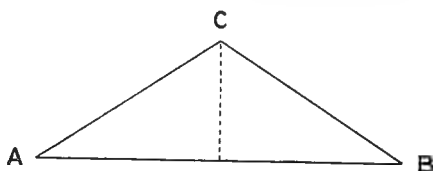

height of the angle, given as 5 feet. The rule to obtain the area of this angle is to multiply the base by half the height, or the height by half the base; taking the former, the sum stands,  $15 \times 2\frac{1}{2} = 37\frac{1}{2}$  square feet of area, multiplied by 60 (the length of the building) = 2,250 cubic feet for the roof alone.

Adding this to the amount already found for the body of the building, gives 15,750 cubic feet for the gross contents of the stable.

From this make the deductions, viz., ten horses occupying 18 cubic feet each = 180 cubic feet; eight pillars, 6 inches diameter, 15 feet high—each pillar therefore occupies  $11.78$  cubic feet of space  $\times 8 = 94\frac{1}{4}$  cubic feet.

Deducting  $180 + 94\frac{1}{4}$  cubic feet from the gross amount found, leaves within a fraction 15,476 cubic feet of space for the ten horses; or 1547.6 cubic feet per head.

The next step in examining the sufficiency of ventilation is to obtain the size of all the doors and windows, and any other means of ventilation which may exist, such as Sheringham valves, tubes, ridge opening, etc.

Observe whether there are opposite doors and windows, the place on which they open, whether the air is likely to be well mixed in its passage across the stable. Regard all the openings on one side of the building as inlets, and calcu-

late whether under ordinary conditions of wind-velocity they will admit sufficient air for the whole of the occupants. The doors had better be omitted from this calculation.

To determine the proper distribution and mixing of air, and also as a guide to the inlets and outlets, generate some smoke by burning a little damped straw, and observe the points noted; do the same with doors and windows closed, and observe the inlets and outlets under these conditions.

The velocity of the incoming air may be accurately measured by means of an anemometer, an instrument with sails which revolve by the wind, the number of linear feet of air which pass in a given time being recorded on a dial. The number of linear feet multiplied by the section area of the opening gives the cubic discharge.

In default of an anemometer, the Beaufort scale of wind, (p. 80) must be employed.

The *examination of the air by the senses* must be made immediately the stable is entered, and the impression at once recorded. The observer should take the greatest care to have been in the open air some little time before making the observation.

This test enables the amount of respiratory impurity to be ascertained with a considerable degree of accuracy, provided the atmosphere is not too impure.

	The Amount of CO <sub>2</sub> per 1,000 Vols. of Air due to Respiratory Impurity is	
When the air smells fresh, or not differing sensibly from the outside air...	...	= .2000
When the air smells rather close	...	= .4132
When close ... ..	...	= .6708
When very close ... ..	...	= .9054

If the amount of respiratory impurity has been estimated as above, it is possible to determine by de Chaumont's equation the amount of fresh air which has been supplied.

$$\frac{e}{p_1} = d \text{ where } e = \text{the amount of CO}_2 \text{ exhaled per hour in} \\ \text{cubic feet, viz., 3.}$$

$$p_1 = \text{the observed ratio of vitiation per 1,000} \\ \text{volumes.}$$

Let us suppose on entering the stable the air smells close; from the table the amount of respiratory vitiation present would be about .6708 per 1,000 volumes of air, therefore

$$\frac{3}{.6708} = 4.46.$$

As the observed ratio is expressed per 1,000 volumes the answer must represent the *number of thousands* of volumes; in the above example, each horse was supplied with 4,460 cubic feet of fresh air per hour, instead of 15,000 cubic feet.

*Estimation of Carbonic Acid.*—If possible the examination by the senses should be supplemented by the determination of carbonic acid in the building. The process is a very simple one and depends upon the power lime or baryta water has of absorbing carbonic acid. The alkalinity of either of these is first ascertained by a solution of acid of known strength; after absorbing carbonic acid the baryta or lime water loses a certain amount of its alkalinity, and the amount of this loss is determined by again treating with the standard acid solution; the loss represents the carbonic acid absorbed.

As the process is conducted in a jar of known capacity, it is simple to calculate the amount for every 1,000 volumes of air in the building.

This process, known as Pettenkofer's, requires some training in volumetric analysis, the difficulties attached to it may be overcome by the employment of Angus Smith's test, which is a rough method but capable of yielding fairly accurate results, and is worked on the principle of the turbidity produced in lime water by the presence of carbonic acid.

Into a certain number of bottles of known capacity half an ounce of clear lime water is introduced, the air in the bottle is shaken with the lime water, beginning with the small bottles and gradually working up to the larger ones. That bottle in which the first visible turbidity appears is the one accepted as representing the amount of carbonic acid present.

If turbidity appears in a 6-oz. bottle with half an ounce of lime water, the amount of carbonic acid in the air is about 1.1 parts per thousand. With a 10½-oz. bottle the amount is .62 per 1,000; if a 15½-oz. bottle .42 per 1,000.

The bottles should be first filled with water, then emptied in the place where the sample of air is being examined, the lime water at once added, the bottle securely stoppered and well shaken. Angus Smith recommends ten or more bottles to be employed, and a table constructed from the above data of the indications of the amount of CO<sub>2</sub> each represents.

Another method adopted by Dr. Angus Smith for rapidly determining carbonic acid is by aspirating into a double-necked bottle, by means of a rubber ball, a known volume of air. The bottle contains a solution of baryta, and the process is at an end when the turbidity is such that a paper with writing on it can no longer be read when looked at through the base of the flask. A scale is given showing the volumes of CO<sub>2</sub> per 1,000 volumes of air for each aspiration of the ball.

The simplest method in the absence of this graduated apparatus would be to use an ordinary rubber syringe as an aspirator, and perform two experiments, one in the outside air and one in the stable; the impurity of the latter would thus be readily arrived at.

It is most important to bear in mind in employing the lime or baryta test for carbonic acid, that samples of air are not selected near the stable floor. Owing to the presence of ammonia the alkalinity of the lime or baryta water is increased, and fictitious purity of air thus obtained.

Samples should be selected four to six feet above the ground.

*Determination of Organic Matter.*—A known volume of air, say 12 cubic feet, is slowly drawn through distilled water by means of an aspirator. The water is then submitted to the free and albuminoid ammonia process, which can only be carried out by an expert; it becomes in fact a water analysis.



The presence of *ammonia* in stable air is generally recognisable by the senses without any chemical test. Ordinary blotting-paper soaked in a solution of logwood turns purple in the presence of ammonia; papers soaked in Nessler's solution are an exceedingly delicate test.

*Sulphuretted hydrogen* may be determined by the use of papers soaked in a solution of lead acetate.

The amount of *watery vapour* is ascertained by means of the wet and dry bulb thermometers, or by the hygrometer.

The *temperature* outside and inside the stable should be recorded. If no artificial heating be practised, the greater the difference in temperature the greater the air impurity.

The *microscopical examination of the air* is more easily accomplished than the chemical, but gives far less practical information. A simple method is to expose for some hours in the stable a slide moistened with glycerine, to which the floating particles in the air adhere.

There are other more elaborate methods, such as drawing by means of an aspirator a known quantity of air through a tube terminating in a drop or two of glycerine; or drawing a known quantity of air through a glass tube containing nutrient gelatine. In the latter the solid particles adhere, the colonies grow and may readily be counted, and thus the number of living organisms in a known volume of air can be estimated.

A simple plan, to obtain the invisible vapour of the atmosphere in the form of water, and with it the solid particles, is to place some ice in a vessel; the moisture condenses on its surface and runs down, and may be collected and examined.

Finally, the examination of the air should be made at night some hours after the stable has been occupied.

## CHAPTER IV

### FOOD

THE food and feeding of animals is a subject of social economy. Feeding in relation to agriculture is a question of paramount importance to the owner and rearer of stock ; to have the best results at the lowest possible cost the feeding of animals must be based on a scientific foundation. The results of practical experience have taught the British farmer and grazier facts connected with feeding, the why and wherefore of which he seldom understands, but which science has no difficulty in explaining. There can be no doubt that if to all interested in the feeding of animals a little scientific instruction on this most important subject were given, much disease and a large annual loss would be saved.

It has been repeatedly pointed out that the problem of stock-management resolves itself into the question of 'how to feed.' It is not sufficient to know that certain substances possess great nutriment, and that others are practically useless, but it must be known what foods are most suited to the varying conditions of the organism, in what form these should be administered, and to ascertain how the best feeding can be obtained in the most economical manner.

In considering the feeding of horses, the object aimed at is to obtain the maximum amount of energy at a low cost. With cattle and sheep the question is not one of the production of energy, but the accumulation of flesh, the growth of wool, and production of milk for the purpose of human food.

Dieting as dealt with by the human hygienist, is much simplified by the fact that he has only one system of digestive organs to deal with; but with the veterinary hygienist the matter is different, he has at least three, and if we considered the feeding of dogs, four totally different arrangements of digestive canal to legislate for. What is right and proper for one is quite unsuited to the other; the feeding of cattle differs much from the feeding of horses, and the feeding of swine is different from either.

The arrangement of the digestive apparatus of animals has an important bearing on their system of feeding. The small and single stomach of the horse, the capacious bowels, and the absence of a gall bladder, are in marked distinction to the enormous stomachs of the ox, the small intestines, and the presence of a gall bladder. Such anatomical differences in animals both belonging to the class herbivora, point to considerable difference in their process of alimentation.

The following table, compiled from Colin,\* will show how different are the proportions in every 100 parts of the gastro-intestinal organs of various domesticated animals :

	Stomach.	Small Intestines.	Cæcum.	Colon and Rectum.
Horse ...	8·5	30·2	15·9	45·4
Ox ...	70·8	18·5	2·8	7·9
Sheep ...	66·9	20·4	2·3	10·4
Pig ...	29·2	33·5	5·6	31·7

The ratio between the length of the body and that of the intestines is as follows: Horse, 1 : 12; ox, 1 : 20; sheep, 1 : 27; pig, 1 : 14.

Putting aside the differences in the horse and ox in the arrangement of the teeth, salivary and biliary secretion, rumination, etc., we have sufficient data in the above to

\* 'Physiologie Comparée des Animaux.'

show how entirely opposite the digestive apparatus is in the two animals, and it gives us some insight into the process of their nutrition.

The object of food is to build up and repair the tissues, and maintain a reserve for the body requirements; these requirements are energy and animal heat. Food as received into the digestive tract is quite useless for the purpose of the body; before it can be utilized it must form part and parcel of the animal, either in the solid or fluid tissues.

Food by being absorbed and passing through the membrane of the stomach and intestines into the general circulation, practically becomes converted from dead into living material; this may not be literally true, but it makes clear the fact that until the food supply finds its way into the tissues of the body it is of no use. The digestive tract from this point of view may be regarded as outside the body.

If the tissues of the animal be submitted to analysis, they are found to group themselves under the following heads:—

- (a) Nitrogenous tissues, containing carbon, hydrogen, oxygen, and nitrogen.
- (b) Non-nitrogenous tissues, containing carbon, hydrogen, and oxygen, nitrogen being absent.
- (c) Mineral matters.
- (d) Water.

The proportion of these existing in an animal must necessarily vary with the condition, or even from day to day; still it is remarkable how closely the proportions are maintained, even in animals of different classes.

In the following table\* the animals were in a half fat condition, and the percentage proportion of the constituents of the body are calculated after deducting the contents of the stomach and intestines.

Lawes and Gilbert.

	Ox.	Sheep.	Pig.
Nitrogenous tissues ...	18.3	16.0	15.0
Non-nitrogenous tissues ...	17.5	21.3	24.2
Mineral matter ... ..	5.2	3.8	2.9
Water ... ..	59.0	58.9	57.9
	100.0	100.0	100.0

Food must supply the needful material for the repair of these tissues, it should therefore consist of :—

Nitrogenous matters,  
Non-nitrogenous matters,  
Mineral matters,  
Water.

None of these must be absent, one cannot replace the other ; further, one can only act satisfactorily in the presence of the other.

The following classification of foods is generally adopted :

Organic	{	Nitrogenous	{ Proteids and albuminoids.
		Non-nitrogenous	{ Carbo-hydrates, fats, and vegetable acids.

Inorganic : Mineral salts and water.

Each of these groups must be considered in detail.

#### NITROGENOUS OR PROTEID SUBSTANCES.

The type of all nitrogenous matter is albumen, by which the name of the class is commonly known. It is not a single nor a simple substance, but a highly complex group, possessing certain chemical features in common, and others characteristically different, by which their grouping is mainly determined.

The class termed PROTEIDS consists of *native albumens*, *derived albumens*, *globulins*, *fibrins*, *albumoses*, and *peptones*.

Under the designation ALBUMINOIDS is grouped proteid substances closely allied to albumen, yet differing from it in some important particulars, and to this class belongs *gelatin, mucin, keratin, etc.*

Most of these animal proteids and albuminoids have their counterpart in the vegetable kingdom. The plant can obtain its nitrogen from ammonia and nitrates, and elaborate this into the complex proteid. The animal obtains its supply of nitrogen through the complex proteid molecule, but is unable to utilize nitrogen obtained from such simple substances as ammonia and nitrates.

In animal proteid matter albumens predominate, whereas in vegetable proteid globulins exist in larger amount than albumens; in oats, maize, and peas, nearly the whole of the proteid exists as globulin.

When proteids and albuminoids are submitted to analysis they are found to contain

				Per Cent.
Carbon	...	...	...	52-54
Hydrogen	...	...	...	7
Oxygen	...	...	...	21-24
Nitrogen	...	...	...	15-17
Sulphur	...	...	...	1- 1.5

There is a remarkable similarity in composition of all albumens. Some contain more carbon than others, and some are richer or poorer in nitrogen than others, but these differences which enable the chemist to group them, do not suffice to lead to their identification. On the whole it may be said that vegetable albumen contains more nitrogen and less carbon than animal albumen.

A diet which contains no nitrogen, no matter how rich it may be in other principles, is a starvation diet. There is nothing which can replace proteid in a food, even the albuminoids, gelatin, chondrin, and keratin, have not the same nutritive value as albumen itself, and cannot replace it.

With one or two exceptions no animal can live on a purely meat diet; at some point or other the vegetable

kingdom has to be drawn on. We have previously seen it is quite capable of supplying the needs of the body, as the vegetable contains the same constituents as those found in the animal.

When animal or vegetable proteid is digested it undergoes a change in the stomach into peptone, while in the bowels the peptone breaks up into certain amides, known as leucin and tyrosin, thus carrying the stage of proteid disintegration a step further. In the liver the leucin is converted into urea which completes the final breaking up of proteid. Urea is distinguished from proteid in being a remarkably simple substance. As might be expected, the different proteids do not all yield the same amount of decomposition products in the process of digestion.

In the plant *amides* may also be found especially at an early stage of its growth.

Young growing clover, lucerne, and grass, contain a good deal of amides; as the plant approaches maturity they become less in amount.

The amides contain nitrogen, but not having the feeding value of proteid, it is necessary to know how much of the total nitrogen found in a plant is albuminous, and how much amide.

We have mentioned that in the animal body the amides result from the breaking up of proteid; in the vegetable, on the other hand, there is evidence to show that it may be part of the process of proteid construction.

Animals have been fed with vegetable amides, and experiments show that by becoming decomposed in the body they economise the body proteid, so that if they cannot replace proteid in a diet they are not entirely without value. In the body these vegetable amides yield urea.

In spite of these considerations, it is desirable in the present state of our knowledge to regard amides as of very little nutritive value in a diet.

Here is a table\* showing the proportion of albu-

\* 'Farm Foods,' Wolff.

minous to non-albuminous nitrogen in the chief feeding stuffs :—

NITROGEN IN FOOD STUFFS EXPRESSED AS ALBUMINOID AND NON-ALBUMINOID.

	Total Nitrogen = 100.	
	Albuminoid.	Non-Albuminoid.
Meadow hay ... ..	87.2	12.8
Pasturage from meadows	73.0	27.0
Meadow grass ... ..	84.0	16.0
Young grass ... ..	73.0	27.0
Lucerne ... ..	67.0	33.0
Mangels ... ..	23.5 to 65.1	34.9 to 76.5
Barley ... ..	97.1	2.6
Oats ... ..	92.5	7.5
Maize ... ..	95.1	4.9
Beans ... ..	88.6	11.4
Linseed cake ... ..	94.0	6.0

It has been previously stated that a diet without nitrogen is one of starvation, this is evidence of the paramount necessity of proteid. Yet so complex is the subject of nutrition, that in spite of elaborate observations carried on for years, we have got very little nearer to a clear conception of the real use of proteid in food.

We quite understand that it builds up the proteid and fat tissues of the body, and so forms muscle, fat, wool, and milk. But strange as it may appear, it is not the source of muscular energy, though without nitrogen effective muscular work becomes impossible.

The suggested explanation of the paramount necessity of proteid in a diet, is that it determines the absorption of oxygen, without which no energy is possible. This explanation is, however, imperfect.

There are certain clearly ascertained facts in connection with proteids :—

1. It is very extravagant, and with most animals impossible, to feed with proteid exclusively. By doing so part of the proteid has to be utilized in the production of fat, and fat produced from proteid is extravagant.



2. Much less proteid suffices for the body requirements when a proportion of fat exists in the food; this economising influence of fat is better marked in carnivora than herbivora.

3. Carbo-hydrates exercise a marked preservative action on proteids in herbivora, and effect a true economy. Less proteid is required in the presence of carbo-hydrates, and further, it is better digested.

Much of the experimental feeding work carried out by Agricultural Stations abroad, has been directed towards ascertaining what proportion the carbo-hydrates should bear to the proteid substance in a diet, under different conditions of nutrition.

(a) It has been clearly shown that if the amount of supplied proteid is small, while the carbo-hydrates are large, very little fat can be stored up.

(b) If the carbo-hydrates given be small, and the proteid increased, greater metamorphosis of the proteid tissue occurs, a greater amount of urea is excreted, and only a small quantity of proteid and fat are stored up.

(c) If the proteid and carbo-hydrate be supplied liberally, and in a definite ratio of proteid to carbo-hydrate, both albumen and fat are stored up in the body.

The ratio of proteid to carbo-hydrate food is known as the *nitrogenous or albuminoid ratio*, a consideration of which had better be deferred until the question of fats and carbo-hydrates has been dealt with.

#### NON-NITROGENOUS SUBSTANCES.

*Fat.*—The sources of fat in the body are—

1. From the fat contained in the food.
2. From that portion of the proteid not converted into urea. There is more carbon and oxygen in proteid than is required to unite with the whole of the nitrogen to form urea, and this excess of carbon and oxygen is stored up as fat. One hundred parts of water free proteid can produce

33.5 parts of urea, 51.4 parts of fat, and 27.4 parts of carbonic acid.

3. From the carbo-hydrates in the food.

Dealing first of all with the fat in the food, this in the diet of herbivora is very small, the crude fat in vegetable tissues exists only in trifling amount, and is more of the nature of wax, which is indigestible. In cereals such as oats and maize, a fairly pure fat may be obtained.

The fat in the food to be of any use must be allied to the animal fats, foreign fats are either not absorbed, or are rapidly oxidised. The fat found in vegetable tissue (excluding the wax), is very similar to the body fat, and is therefore capable of being utilized.

Fat produced from proteid is more easily oxidised in the body than the fat originally existing in the food, and the fat from the food is more easily utilized than the fat actually deposited in the tissues.

The formation of fat from carbo-hydrate is beyond all doubt, but before conversion into fat it must first be changed into sugar. Sugar is more easily oxidised than fat, and thus starch exercises a protective influence over the body fat, and at the same time, as previously pointed out, economises the consumption of proteid.

#### *Carbo-hydrates.*

This constitutes a large and important group in the vegetable kingdom, and is represented by starch and its derivatives, the various forms of sugar, and cellulose.

Starch is a highly complex substance contained within the grain of plants. The starch granules vary in shape depending upon their source, those of potato, beans, wheat, etc., are microscopically quite distinctive.

In grains and roots the amount of carbo-hydrate in the form of starch or sugar is very evident, but with grass, hay, and fodders generally, these are largely replaced by gummy material, very little starch or sugar existing.

In the digestive system all starch and other allied bodies

are converted into sugar by digestive ferments before they can be absorbed; so that in the herbivora an enormous amount of sugar is constantly passing from the intestines into the blood. In spite of this only mere traces of sugar are found in the blood, and one explanation is that it is rapidly destroyed by oxidation.

The influence of starch on the metabolism of proteid is very remarkable, it preserves it from destruction, and hence less proteid is required when the diet contains a due proportion of carbo-hydrate than when it is deficient. Carbo-hydrates produce a greater economy of proteid than fat does, but it must exist in a definite proportion to proteid in order to have the most economical effect.

During work it is the fat, but more particularly the carbo-hydrates, which are used up; with ordinary work the using up of proteid in the body is no greater than during rest. This only holds good provided the proper proportion of carbo-hydrate is present in the diet, if it is insufficient the proteid is drawn upon and the animal loses weight.

*Cellulose.*—The fibre found in plants consists of two kinds, the hard or *Lignin* fibre, and the digestible fibre known as *Cellulose*.

Much discussion has occurred respecting the digestion of cellulose, and we will refer again to the subject in dealing with the question of the digestibility of food. It is quite certain that the herbivora can digest it, but whether by a cellulose dissolving enzyme, or by the process of putrefaction in the digestive canal is unknown.

When cellulose is dissolved it is converted into sugar, and passes into the blood as such. The lignin of all plants is indigestible.

Excepting fat, we may regard all the non-nitrogenous substances which are capable of absorption, viz., starch, sugar or sugary substances, gums, and cellulose, as having the same composition as starch, and producing the same effect when absorbed.

The organic acids, viz., acetic, butyric and propionic, produced during digestion from starch, sugar, and cellulose,

cannot be included in this statement, but their amount is small.

To sum up the use of fat and carbo-hydrates in a diet we may say :

1. They exercise a remarkably economic effect on the wear and tear of proteid tissues.

2. They are force producers as they liberate energy on oxidation.

3. They are also heat producers and maintain the temperature of the body.

The *Vegetable Acids* consist of oxalic, tartaric, malic, and citric, united to lime, soda or potash.

In the body they are combusted, and the bases being set free unite with carbonic acid to form carbonates, which are eliminated with the urine and other secretions. In this way they maintain the alkalinity of the blood and body fluids.

The vegetable acids are of undoubted value in nutrition ; the best evidence of which is that by their administration scurvy in the human subject is prevented, when vegetable diet is deficient or absent.

#### INORGANIC SUBSTANCES.

*Mineral Matter.*—The salts found in the food must agree with those required by the body. About four-fifths of the total salts in the body are a compound of phosphoric acid and lime, while one-fifth is composed of potash, soda, magnesia, iron, chlorine, etc. In quantity potash and soda come next to lime and phosphoric acid.

Vegetable diet furnishes much more potassium than sodium salts, which explains the universal practice of taking common salt with vegetables like potatoes, and the addition of it to the diet of herbivora.

Growing animals require more salts than adults, and we see this provided for in the composition of milk. A calf will store up daily for a year 277 grains phosphoric acid,

and 307 grains lime. Rather more than this daily requirement is contained in two gallons of milk.

Cows in milk require more than fattening oxen, for the reason they are losing so much through the secretion. It has been calculated that a cow requires 1·44 oz. phosphoric acid, 2·08 oz. lime, and 3·78 oz. potash daily, and this amount is contained in 30 lbs. hay which yield 2 oz. phosphoric acid, 4 oz. lime and 6½ oz. potash.

Fattening oxen require daily ·8 oz. phosphoric acid, 1·6 oz. lime and 3·2 oz. potash.

Growing sheep will use up daily 40 grains potash, 15 grains soda, 30 grains lime, 4 grains magnesia, and a varying quantity of phosphoric acid which increases month by month, from 20 grains to 45 grains daily.

The function of the salts in food is the building up of the body tissues, and furnishing the necessary material for the secretions. A salt-free diet would result in death; but it would take a little time, as experiment shows that as soon as any particular salt is deficient in the food, the system doles out the deficiency very slowly from that which has previously been stored up in the body.

The final behaviour of salts in the body, viz., their digestibility, is a question which is not fully worked out. A great deal is excreted with the fæces unacted upon, for instance phosphoric acid and magnesia in the horse, and lime in the case of ruminants. With the urine of the horse a considerable amount of lime is excreted, and the whole of that must have been absorbed from the intestinal canal before it could gain exit by the kidneys.

The foods richest in phosphoric acid are oil-cake and bran, while hay and straw are the poorest in these matters.

Lime is largely found in clover, meadow hay, bean straw, and turnips, but only in small quantities in the cereals. Maize is so poor in lime that it would be an unfit food for a growing animal without soluble lime being supplemented.

Potash exists largely in roots, hay, bean straw, bran, and oil-cake, but in the cereals it only exists in small quantities.

Regarding the use of *Common Salt* as an addition to the

diet of horses, it is quite certain that animals can be kept in perfect health on the small amount of sodium salts which exist naturally in the food.

Custom, however, demands that they shall have more, and it is beyond doubt that if salt be supplied it is partaken of voluntarily, which may or may not argue necessity. One ounce a day of common salt should not be exceeded, and half an ounce would probably meet all possible requirements.

In fattening stock there is an objection among farmers and others to giving salt, and such objection is not perhaps without reason, as anything which causes more fluid to be consumed interferes with fattening. Salt in moderation can do no harm, and by imparting a flavour to food may cause animals to eat more.

For milch cows half an ounce a day stimulates secretion, and by causing a greater consumption of fluid increases the bulk of milk produced.

Perhaps for all animals the best form in which to administer this condiment is in the form of rock-salt placed in the manger or crib.

The amount of *Water* in vegetable food depends upon the condition of the substance. Grass, roots, and such like contain from 70 to 90 per cent. of water; hay and the various feeding grains contain from 14 to 16 per cent.

Less water is consumed with a diet rich in water, than in one where the food is dry. Common observation shows how undesirable it is for working animals to be fed on a watery diet, as the amount of material to be consumed in order to supply the body requirements is excessive.

The same holds good for fattening animals; very watery food increases the consumption of proteid and delays the process of fattening. Even with cows it is undesirable for the food to be too watery.

Water represents rather more than half the body weight of an adult animal. In early life the proportion is still higher, amounting to 80 per cent., but during the process of growth it decreases.

## NITROGENOUS, ALBUMINOID OR NUTRITIVE RATIO.\*

More than once in the foregoing pages, we have remarked that there is an effective proportion which the nitrogenous constituents of a food or diet should bear to the non-nitrogenous; any departure from this is an error in feeding and wasteful. One of the principal pieces of work accomplished by the experiments carried on at feeding stations abroad, especially in Germany, is the important one connected with the ratio the proteid in a diet should bear to the non-proteid food.

If the proteid be in excess it is wasteful, not only to the pocket of the feeder but also to the system of the fed, for excess of proteid gives rise in the system to destruction of body proteid.

Excess of non-nitrogenous material causes an unnecessary tax on the digestive organs, and further it reduces the digestibility of proteid; it produces a 'depression' in their digestibility.

The most favourable albuminoid ratio in a diet, be the animal intended for work, food, wool or milk, is one part of proteid to from four to seven parts of non-proteid substance.

This statement is the outcome of an immense amount of research extending over years, and the result of most carefully planned experiments. If the nitrogen in a diet is higher than one part to four of non-nitrogenous, or lower than one part to seven of non-nitrogenous, we may be certain it is economically wasteful.

In order to calculate the albuminoid ratio of any food or diet the digestibility of the material must be known. The

\* Throughout this chapter on Food, but more particularly in the sections dealing with Nutritive Ratio and Digestibility, I have been greatly influenced by the experimental work done at the various agricultural stations in Germany, France, and the United States. I desire particularly to acknowledge my indebtedness to the work of Professor Emil v. Wolff, of Hohenheim, Wurtemberg, whose monumental labours have been so well placed before the English reader by Mr. H. M. Cousins, M.A., in 'Farm Foods.'

question of digestibility will be dealt with later; for our present purpose it is sufficient to say that only a portion of the proteid and non-nitrogenous substances in any diet is capable of absorption, the remainder is excreted with the fæces.

The albuminoid ratio is calculated not on the total amount of proteid and carbo-hydrate in the diet, but only on that definite proportion which numerous experiments have shown is capable of being extracted from it by the system. The albuminoid ratio, then, is calculated on the digestible constituents of a diet.

The digestible constituents of a diet which have to be considered are, proteid, fat, and carbo-hydrate. In the latter is included not only the starch in the food, but all the non-nitrogenous substances capable of digestion, viz., sugar, gummy substances, cellulose, etc., which we have previously said when absorbed have the same nutritive value as starch.

It will be borne in mind that the proteid of vegetable tissues is made up of albumen proper and amides, the latter being described in the table on p. 96 as non-albuminous nitrogen. In calculating the amount of digestible proteid in a diet, both of these are included, as in the present state of our knowledge the real function of amides is not accurately known.

The fat is calculated as pure fat, though again it will be remembered that excepting in cereals the fat is mainly of the nature of wax, and has not the same value as pure fat. The digestible fats in the diet are multiplied by the factor 2.44, by which factor the fat (calculated from the oxygen required for its combustion) is converted into its equivalent of starch. In other words, the fat is regarded as giving nearly two and a half times more heat than starch. Finally, all the remaining digestible non-nitrogenous constituents are taken and regarded as equivalent to starch.

We have now arrived at the necessary data for calculating the albuminoid ratio of any food or diet, viz., it is only to be calculated upon the digestible portion of the



proteid, fat, and carbo-hydrates. The fat is to be multiplied by 2.44 to bring it to its equivalent in starch, and added to the carbo-hydrates; the product of these is to be divided by the proteid.

*Example.*—What is the albuminoid ratio in a diet consisting of 12 lbs. hay and 10 lbs. oats?

The above diet possesses the following amount of digestible principles

					lbs.
Proteid	...	...	...		1.6
Fats	...	...	...		.5
Carbo-hydrates		...	...		8.4
Fat	...	...	...	$.5 \times 2.44 = 1.22$	
Carbo-hydrate	...	...	8.4	$= 8.40$	
				<hr style="width: 50%; margin-left: auto; margin-right: 0;"/>	9.62

The nitrogenous ratio is therefore

$$1.6 : 9.62 \text{ or } 1 : 6.$$

The normal food of herbivora, viz., grass, has an albuminoid ratio of from 1 : 4 to 1 : 6. In hay the albuminoid ratio is low, viz., 1 : 8, and this could only be of use in animals intended for slow work, or for those about to be fattened. Such a low ratio would only produce flesh, fat, and milk, very slowly.

Young clover before flowering has an albuminoid ratio of 1 : 3 to 1 : 4; the diet if exclusively clover would be excessively nitrogenous and cause waste of proteid; in such a case the ratio can be lowered by the addition of straw or chaff. Clover hay has a ratio of 1 : 5 to 1 : 6.

In cereals the ratio lies between 1 : 5 to 1 : 7. In leguminous seeds it is very high, 1 : 2 to 1 : 3, while in oil-cake it is still higher, 1 : 1 to 1 : 2.

#### DIGESTIBILITY OF FOOD.

The digestibility of a food is its power of undergoing absorption into the body for the purpose of nutrition. In every food given to animals there is a distinct digestion of

the proteid, fat, and carbo-hydrate in it. The amount of these which are absorbed under favourable conditions is fairly definite, but under unfavourable conditions, such as the food being 'badly saved,' or there being too much carbo-hydrate present, or too much or too little proteid in the diet, the amount absorbed departs from the normal, and less is extracted or less stored up than would have been the case had conditions been favourable.

Every food given to animals has a portion of its nutritive matter unacted upon, which is excreted with the fæces, together with such indigestible substances as lignin.

The amount of nutritive matter absorbed from each food-stuff varies with the class of animal, the nature of the food, and its state of preservation. It is the same for each food, and each class of animal, provided the digestive apparatus is in good working order, though of course there are some marked individual differences.

The amount absorbed cannot be increased or decreased by the amount of food given; the proportion absorbed is quite independent of the amount supplied. Further, it is quite unaffected by rest or work. The only thing which seriously affects the amount of nutritive principles absorbed, and causes them to depart from the normal, is the proportion which the non-nitrogenous principles bear to the nitrogenous in a mixed diet.

The amount of absorbed proximate principles of any food is expressed as a percentage of the total amount supplied; thus 69 per cent. of the proteids in hay are digested by a horse; 90 per cent. of the fat in linseed cake are digested by cattle, and 39 per cent. of the carbo-hydrates in straw are digested by sheep. These numbers are termed the *Digestive Coefficient*, and are expressed by saying the coefficient of digestion of the proteids in hay is 69, of fat in oil-cake is 90, of carbo-hydrates in straw is 39.

Here is a table\* of digestive coefficients for horses, oxen, and sheep, of the principal feeding stuffs. It must

\* Extracted from a series of elaborate tables by Prof. Emil v. Wolff, 'Farm Foods.'

be borne in mind these are averages from numerous experiments.

DIGESTIBILITY OF FOOD STUFFS, SHOWING THE PROPORTION DIGESTED FOR 100 SUPPLIED.

Food.	Animal.	Total Organic Matter.	Proteids.	Cellulose.	Fat.	Carbo-Hydrates.
Green grass	Horse	51	59	41	20	59
	Ox	77	75	75	66	78
	Sheep	62	60	61	52	66
Hay ...	Horse	48	57	36	24	55
	Ox	60	57	58	49	62
	Sheep	59	57	56	51	62
Clover Hay	Horse	51	56	37	29	64
	Ox	57	55	45	51	65
	Sheep	56	56	50	56	61
Lucerne ...	Horse	58	73	40	14	70
	Ox	62	78	42	33	70
	Sheep	59	71	45	41	66
Wheat Straw	Horse	23	19	27	—	18
	Ox	46	17	56	36	39
	Sheep	48	—	59	44	37
Oats ...	Horse	67	79	20	70	74
	Ox	70	78	20	83	76
	Sheep	71	80	30	83	76
Barley ...	Horse	87	80	100	42	87
	Ox	86	70	50	89	92
Maize ...	Horse	89	77	70	61	94
	Ox	91	72	77	85	94
	Sheep	89	79	62	85	91
Beans ...	Horse	87	86	65	13	93
	Ox	89	88	72	86	93
	Sheep	90	87	79	84	91

A glance at the column 'Organic Matter,' shows that of the total organic matter in the foods mentioned, the horse digests the least, and as a rule the ox digests the most. The other columns in the table show that compared with

the ox and sheep, the digestion of the horse is as a rule inferior to ruminants in the matter of cellulose, fat, and carbo-hydrates, while in the matter of proteids he holds his own.

Before proceeding to describe the causes influencing the digestibility of certain foods, it is desirable to consider the question of the digestion of cellulose.

*Cellulose Digestion.*—The horse, ox, and sheep can digest cellulose, the pig and human subject are practically unable to deal with it. The cellulose is mixed up with the other fibre in the food, but either by the process of decomposition brought about by organisms in the digestive canal, or by the presence of a cellulose dissolving ferment—which has never been isolated—a certain proportion varying from 30 to 70 per cent. in different animals is rendered soluble, and is pure cellulose having the same composition as starch.

There is great difference of opinion as to whether the cellulose when isolated is of much economic value. Experiments on the horse conducted with great care show it to be useless for the purpose of work. Other observers have stated that it exercises an economical influence over the destruction of proteid.

Fermenting cellulose yields 60 per cent. of fluid fatty acids, butyric and propionic, while a smaller quantity is given off as marsh gas and carbonic acid. Neither the fatty acids nor the marsh gas can be of any use in nutrition, so that observers believe that not half the cellulose dissolved can have the same function as starch.

The view at present adopted is that ruminants are probably able to utilize cellulose to better effect than the horse, and that with the latter the most careful observations appear to show that for the production of work cellulose is useless.

Before entirely accepting this position, our knowledge of cellulose must be advanced, at present we know extremely little about it, and it seems a waste of energy for a digestive system to be able to dissolve a food substance, and yet not to be able to utilize it.

There are certain conditions which affect the digestibility of foods, and may cause them in some cases to depart from the normal standard of digestion, and these we must study in some little detail.

*Conditions affecting the Digestibility of Food.\**

*Quantity.*—The proportion of digested proximate principles in a food, is quite unaffected by the quantity given. No more or no less is digested be the quantity supplied great or small.

*Chemical Composition.*—The amount of food digested is greatly influenced by its chemical composition, and this is determined by the nature of the soil, manuring, and season.

*Green and Dry Fodder.*—Both of these are equally digestible if the dry fodder be well saved. But in haymaking this is seldom the case, there is often damage done, and this leads to loss of digestibility.

*Effect of Storage on Fodder.*—As the result of keeping there is a loss in the digestibility of proteid matter, and further a loss from the breaking off of the dry portions of the plant containing the more nitrogenous substances.

*Period of Growth.*—The younger the plant the more proteid and more cellulose is digested. Hay cut too late has lost much of its nutritive properties, and accordingly less of it is digested.

*Method of Preparation.*—No method of preparation, be it scalding, steaming, crushing, or bruising can help in digestion; no more is digested by adopting these methods, while sometimes the digestibility is reduced, especially by scalding and steaming. The only thing gained by scalding, steaming, etc., is a probable increase in the palatability of the food, and the development of flavour.

*Influence of Work.*—Work has no influence in creating an appetite, or in causing a larger proportion of food

\* The remarks on this subject are summarised from Wolff's 'Farm Foods.'

substances to be digested. Excessive work may cause a slight decrease in the amount digested.

*Different Kinds of Animals.*—No important difference is observed in the amount of forage digested by oxen, cows, sheep or goats. Oxen digest hay rather better than sheep, while sheep digest clover hay rather better than oxen, so that compensation occurs.

Horses, on the other hand, digest less hay than ruminants, this reduction being confined to the fat, carbohydrates, but particularly the cellulose. Of the total nitrogen free matters in hay, the horse digests 20 to 25 per cent. less than ruminants.

*Individuality.*—This exercises a marked effect on digestibility. Apart from age, defective teeth, and weakened digestion, animals of the same species, breed and age, may show differences in digestive power amounting to from 2 to 4 per cent. of the dry matter in food.

*Effect of Corn added to Hay.*—This produces under ordinary circumstances no effect on the digestion of hay, provided an albuminoid ratio of 1 : 5 or 1 : 6 is maintained. A 'depression' in digestibility is observed when the ratio falls to 1 : 7 or 1 : 8.

*Effect of Starch added to Hay.*—Large quantities of carbohydrates reduce the digestibility of both the proteids and cellulose in hay, and this holds good for all animals. This 'depression' in digestibility is not considerable until the carbohydrate amounts to 25 or 30 per cent. of the total dry matter in the hay, though it is much greater if straw forms part of the diet. This depression can be removed by the addition of nitrogenous food, in other words, by raising the albuminoid ratio.

These observations show how necessary it is in the feeding of cattle, to avoid the excessive use of 'roots' with fodder, excepting the total nitrogen in the diet be raised.

The *addition of oil* to a diet does not increase the amount digested, this is important in the face of the common practice of adding linseed oil to the food of horses out of condition. If the fat given be part of the food, as in linseed,

then loss of appetite and digestive disturbance are not so likely to follow the excessive administration of fat. The fat, however, does not alter the digestibility of the food.

The *addition of salt* to a diet is equally ineffectual in causing a larger percentage of digestibility, though by improving flavour it may cause a larger amount of food to be consumed.

#### THE HEAT AND WORK PRODUCING POWER OF FOOD.

At one time it was believed the theoretical heat producing value of a food, was the best means of ascertaining its nutritive usefulness.

This is not correct, the question of the heat yielded by food on combustion is of more theoretical than practical importance, until we can make certain that what occurs in the laboratory may also take place in the animal body.

Proteid, fat, and carbo-hydrates, when burned yield heat; fat yields the most, carbo-hydrates the least. By means of a calorimeter the amount of heat a definite quantity of these substances is capable of yielding has been ascertained, and is expressed as a heat unit. The heat required to raise 1 gramme (15.432 grains) of water 1° C. (1.8° Fahr.) equals one heat unit.

1 oz. albumen	yielded on oxidation	628	English heat units.
1 oz. fat	„ „	1,017	„ „
1 oz. starch	„ „	504	„ „
1 oz. grape sugar	„ „	368	„ „

A calorimeter and the animal body are not identical. Proteid, for example, is not fully oxidised in the body, quite one third of it passes away as urea, so that the heat equivalent of proteid in the body is not the same as it is in the laboratory experiment. In fact, observations show clearly that the heat value of proteid may practically be regarded as identical with starch, while that of fat is about twice as great.

When the heat units a substance can yield are known, its mechanical value is calculated on the basis that the

amount of energy necessary to raise the temperature of one pound of water  $1^{\circ}$  Fahr., is equivalent to raising one pound 772 feet high.

The mechanical equivalent of  $1^{\circ}$  Fahr. is, therefore, 772 foot pounds.

With this data the potential energy, or mechanical value, of the proximate principles of food can be calculated.

1 oz. proteid oxidised in the body yields	170	foot tons of energy.
1 oz. fat	380	“ “
1 oz. starch	138	“ “
1 oz. sugar	130	“ “
1 oz. carbon converted into $\text{CO}_2$	311	“ “

But the total energy which food is capable of yielding is not converted into work ; the muscles of the body compared with an ordinary machine are most economical in their working, but in spite of this in man not more than one-fifth of the theoretical energy of the food appears as work, and recent investigations have placed it even lower.

The muscles of the horse would in this respect appear to be somewhat better engines than human muscles, as both Wolff and Lehmann found that about 31.5 per cent. of the digestible substances in food appeared as work.

The combustion of proteid, fat, and carbo-hydrates in the body has been likened to the combustion of fuel in an engine, viz., that a conversion of heat into force occurs.

Calculations have caused physiologists to believe that twenty to thirty per cent. of the heat in the food was converted into work ; but Wolff takes up a new attitude and objects, with a good show of reason, to the source of muscular power residing in the combustion of the food. He says that an engine and the animal body are not comparable. ‘If a simple conversion of heat into work really takes place in the body, then the increased oxidation of organic matter which takes place during work, must result in a continual and renewed source of muscular power, and render external work possible without any cessation.’

The theory he brings forward is that the food substances



under the influence of oxidation are resolved into simple groups of atoms, and the chemical force which linked these atoms together while in their complex condition, is now set free to be utilized as kinetic energy for the external work of the body. This energy can be stored up in the system until required, and when it is exhausted a period of rest is needed in order that fresh energy may be accumulated.

This question no doubt invades the field of physiology, but is dealt with here to avoid the question of muscular energy being regarded as a purely physical one, due to the production of heat in the body. It is something far more complex, we only know the beginning and end, viz., that food is supplied and work results, but the processes by which these are linked together are quite unknown.

#### THE AMOUNT OF FOOD REQUIRED DAILY.

The loss in the animal body is of two kinds—(1) That dependent on the internal work of the body, such as the action of the heart, movement of the bowels, heat, respiration, etc.; (2) The loss from muscular and other movements.

Two diets are therefore required, the first to allow of a perfectly balanced condition of the body, restoring the loss occasioned by the internal work, so that the body-weight shall remain unchanged; the second to restore the waste of muscular and increased respiratory activity resulting from external work. The first is called the *essential* or *subsistence diet*; the second the *variable diet*.

#### *Subsistence Diet.*

*Horses.*—A large number of experiments have been made to ascertain the smallest amount of food a horse in a state of rest requires, in order to prevent loss of body-weight. In these calculations observers have not adopted a uniform system of dealing with the question of cellulose, and if this is included by some and excluded by others, a discrepancy exists in the amount of carbo-hydrate required for the

internal work of the body. The mean amount of food required by horses doing no work is from 7 lbs. to  $7\frac{1}{2}$  lbs. of *digestible* albuminoids and carbo-hydrates, minus cellulose.

Grandeau and Léclerc found that three horses maintained their weight unaltered for from four to five months on  $17\frac{1}{2}$  lbs. meadow hay. This amount of hay furnished 7.02 lbs. of digestible organic matter for every 1,000 lbs. of body-weight, and contained

Proteid	...	...	...	...	Lbs. .538
Carbo-hydrate	...	...	...	...	6.482
					<hr/> 7.020

This may be accepted as not far from the truth, of what horses in a state of idleness require every 24 hours for the internal work of their body.

*Oxen.*—Numerous experiments have placed the average subsistence diet for oxen at

Proteid	...	...	...	...	Lbs. 0.57
Carbo-hydrate	...	...	...	...	7.40
					<hr/> 7.97

This amount is furnished by 3.7 lbs. clover hay, 13 lbs. straw and 0.6 lb. rape cake.

*Sheep.*—These require more food proportionately than an ox, and the rule holds good that the smaller an animal the relatively larger amount of food it requires, owing to the fact that in proportion to its size the surface it exposes is larger, and in consequence the processes of vital activity are greater. Sheep require for maintenance daily

Proteid	...	...	...	...	Oz. 2
Carbo-hydrates	...	...	...	...	17

These requirements are furnished by 2.75 lbs. hay.

#### *Working or Variable Diet.*

We have now to consider the question of the amount of food required during work, and in spite of the elaborate experiments which have been made on the horse, it must

be acknowledged that from a point of view of exactitude they still leave much to be desired. The fact is, that though horses have been made to perform a definite amount of work under conditions of rigid experimental enquiry, in which the urea and carbonic acid excreted, the oxygen and food absorbed, have been carefully estimated, yet the conditions are necessarily artificial, and cannot resemble work naturally performed, either under saddle or in harness.

Fortunately from a practical point of view the question is not of any serious moment, the owner of horses that work hard knows that liberal feeding is sound economy, and he does not wait to calculate whether the potential energy he is supplying is in excess or not; he gives his horses as much to eat as they can dispose of, and experience completely justifies him.

This in fact is the only system to be adopted with horses performing very hard work, whether they are pulling a heavy van, carrying a man to hounds, or used for racing purposes.

But there is a class of horse performing only moderate work, and for this it is reasonable to expect some recognised standards of diet to be adopted.

What experience tells us is that the amount of food constituents given must depend upon the character of the work, and that the main constituent to attend to is the proteid. The more severe the work the more proteid required, though as will be remembered from what has previously been said, the proteid is not the source of muscular energy, yet without it no energy is manifested.

But unlimited proteid will not admit of unlimited work; muscles are only capable of a certain amount of useful labour, and this amount is probably hardly the same from day to day even for the same individual. There are great differences in the useful effect produced by horses just as there are in men, constitution, temperament, and breed are here important questions, and it is necessary to be reminded of them to avoid the question being considered from too

mechanical a standpoint. There is something more than the machine to be considered, there is the animal.

In spite of what has been said above, it is possible to form an idea of the amount of daily work which a horse may reasonably be called upon to perform, and this amount may be stated at 3,000 foot tons per diem, viz., ten times more than a man.

In some of the exact experiments made in Germany by Wolff, Lehmann, and others, it has been found possible to calculate with exactitude the amount of actual work performed by a horse. In one set of experiments lasting over eight weeks they made the animal produce from 2,600 foot tons per diem, to 7,800 foot tons, but loss of condition was very evident with the latter amount. In another series from 1,500 to 4,500 foot tons of work were performed daily; loss of condition and weight followed the latter, though the diet was liberal. In a third series lasting several weeks from 2,500 to 4,800 foot tons were performed daily.

We shall not, therefore, be far wrong in adopting 3,000 foot tons as the normal moderate work of a horse performed under natural conditions, and the value of this work may be seen in the following table, where it is assumed that the weight of the horse's body and that of its rider amount to 1,000 lbs.

						Foot Tons.
9 hours' work at 3 miles per hour exercises a force equal to 3,000						
5½	”	4	”	”	”	3,000
2¾	”	6	”	”	”	3,000
1½	”	8	”	”	”	3,000
1	”	10	”	”	”	3,000
8 min. 12 sec.		34	”	”	”	3,000

Later on the question of the amount of work to be expected from horses will be considered, but it is permissible here, in the interests of dieting, to draw attention to the extraordinary influence of velocity as shown in the above table. The resistance the animal body meets with during work increases as the square of the velocity, but the force necessary to overcome this resistance increases as the cube.

It has been shown from experiments on men (and these are naturally still by far the most reliable observations), that the amount of food required for work over and above the normal, is not met by a simple increase in proportion to the amount of work performed. If, for example, one-fifth of the total energy in food enables a man to perform a normal day's work of 300 foot tons, the force-producing value of any increase in diet to meet an extra hundred foot tons, is not as high as a fifth, but falls to one-seventh; for the fifth hundred it would fall to one-ninth, and for a sixth hundred to one-eleventh.

This is the explanation of one of the difficulties in attempting to lay down any hard and fast rule as to the amount of work a given quantity of food can perform, and renders the whole question, though of deep theoretical, but of little practical importance.

In the following table,\* however, the amount of work which a given amount of food can produce was ascertained by direct experiment on the horse, the table is not only interesting, but might be turned to practical utility in the calculation of diets.

1 lb. of the dry matter of hay		produces	215	foot tons	of work
"	"	clover hay	"	214	" "
"	"	lucerne hay	"	260	" "
"	"	oats	"	428	" "
"	"	barley	"	490	" "
"	"	maize	"	578	" "
"	"	beans†	"	500	" "
"	"	peas	"	487	" "
"	"	linseed cake	"	545	" "

In this table one must bear in mind the difference in the digestive coefficients for the various foods; for example, one pound of maize produces more work than one pound of oats, for the reason that 20 per cent. more maize is digested than oats.

\* Wolff, *op. cit.*

† It may appear strange that Wolff's table should show maize as producing more work than beans, but his experimental animal only digested 72 per cent. of the beans, which is below normal.

*Scale of Diets for Working Horses.*

The following scale of diets for working horses is arrived at as the result of practical experience. Some elasticity must be shown in dealing with these tables, they are for an average horse; smaller or larger horses may require less or more.

*Diet for Light Work.*

1.			2.		
		Lbs.			Lbs.
Hay	...	10	Hay	...	10
Oats	...	10	Oats	...	8
		—	Maize	...	2
		20			—
					20

No. 1 Diet contains :

No. 2 Diet contains :

		Lbs.	Lbs.
Digestible Proteid	... ..	1·34	1·340
„ Carbo-hydrate	... ..	8·54	9·018
„ Fat	... ..	0·50	0·524
Total Digestible Material		10·38	10·882

*Diet for Moderate to Average Work.*

						Lbs.
Hay	...	...	...	...	...	12
Oats	...	...	...	...	...	12
Maize	...	...	...	...	...	2
						—
						26

This diet contains :

					Lbs.
Digestible Proteid	... ..	...	...	...	1·768
„ Carbo-hydrate	... ..	...	...	...	11·620
„ Fat	... ..	...	...	...	·716
					—
					14·104

*Diet for Hard Work.*

					Lbs.
Hay	...	...	...	...	12
Oats	...	...	...	...	14
Beans	...	...	...	...	1
					—
					27

This diet contains:

					Lbs.
Digestible	Proteid	...	...	...	1·988
„	Carbo-hydrate	...	...	...	11·642
„	Fat ...	...	...	...	·736
					<hr/>
					14·366

The total diet weighs very little more than that for average work, but it is richer and more concentrated.

*Diet for Very Hard Work.*

					Lbs.
Hay	...	...	...	...	8
Oats	...	...	...	...	16
Beans	...	...	...	...	2
					<hr/>
					26

This diet contains:

					Lbs.
Digestible	Proteid	...	...	...	2·152
„	Carbo-hydrate	...	...	...	11·308
„	Fat ...	...	...	...	·796
					<hr/>
					14·256

The total weight of this diet is rather less than that for 'hard work,' but it is more nutritious.

These diets must not be regarded in the light of fixed quantities or fixed ingredients; some of them may be economically wasteful where large numbers of horses have to be fed, as in the stables of big commercial companies.

No mention has been made of bran in any of the above diets, though from one to two pounds a day may be given with advantage. It has been omitted because bran in spite of its analysis is of no use in nutrition, and its action is probably mainly mechanical.

The system of *dieting farm horses* is somewhat different to that for horses in towns and cities. The farmer frequently utilizes some of his root crops, such as swedes and potatoes; he is very often fond of boiled foods, and is generally wasteful with his hay.

How to effect economy in food is a question which will be dealt with later, but the system of feeding farm horses

with boiled and succulent food may be suitable for the slow work they perform, but quite unsuited to town work. These foods fatten, but fat horses are not required when work has to be done, in fact the fat horse is the first to fail, for fat and 'condition' lie at opposite poles.

#### SUBSTITUTIONAL DIETING.

Immense saving can be effected, without in the least degree imperilling the value of the diet, by feeding on a mixture of grains, the mixture depending on the market price. The grain most commonly used in these cases as an equivalent of oats is maize.

There is no department of horse management where practical veterinary work has more appealed to the commercial instincts of the nation, than the considerable saving effected, with no loss of efficiency, by feeding on a mixture of foods. It is the essence of economical and efficient stable management, and is entirely due to the veterinary profession.\*

There are several systems of forming tables for substitutional diets but we prefer the old one of Boussingault's based upon the nitrogen contained in the food. In the table opposite only the digestible proteid in each food substance is shown; this information simply gives the relative richness of the foods, to ascertain whether any economy is effected the market rates must be consulted.

We learn from the table that oats, maize, barley and rye are nearly equivalents and this is found to be so in practice. We learn that bean straw and hay are nearly equivalents, and that five parts of oat straw are equal to one of clover hay. In fact the table can be analysed so as to provide all information likely to be needed for substitutional dieting, though this is of no value unless the market rate of the proposed substitution is cheaper.

\* The pioneer in this work was the late Mr. Charles Hunting of Durham; his publications on 'Food and Work' and 'The Feeding and Management of Colliery Horses' are models of common-sense, clear reasoning, and capacity for observation.



TABLE FOR CALCULATING EQUIVALENTS FOR SUBSTITUTIONAL DIETING,  
BASED ON THE NITROGEN IN EACH FOOD SUBSTANCE.

Food.	Amount of Digestible Proteid in 100 Parts of the Food.	Food.	Amount of Digestible Proteid in 100 Parts of the Food.
Oats ... ..	8·0	Meadow Grass ... ..	2·5
Maize ... ..	8·0	„ Hay (average) ...	5·4
Barley ... ..	7·7	Clover „ „ ... ..	7·0
Rye ... ..	7·8	Lucerne „ „ ... ..	10·1
Wheat ... ..	11·7	„ (Green) ... ..	3·2
Beans ... ..	22·0	Oat Straw ... ..	1·4
Peas ... ..	20·1	Barley Straw ... ..	0·8
Linseed ... ..	20·1	Wheat „ ... ..	0·8
		Bean „ ... ..	5·0
		Pea „ ... ..	3·2

#### PRODUCTION OF FAT.

If this country has been behindhand in studying the matter of digestive coefficients and depression values, the same cannot be said of the subject of fattening animals for the production of meat and manure. The brilliant work in agriculture, entirely the result of private enterprise, carried on for many years by Lawes and Gilbert at Rothamstead, is still the first authority on the subject. What we have to say on the matter is entirely derived from their observations.

In order that an animal may fatten, it is essential that it be supplied with more food than the system requires, so that the excess may be stored up in the form of fat and meat. Experience has proved that liberal feeding is economical; if by liberal feeding an animal can be prepared for market in two years instead of three, there is a distinct saving in one year's keep.

There are certain conditions which influence fattening, such as warmth, quietude, and rest. The way in which these act can be readily appreciated; by keeping animals warm, food which would otherwise be expended in main-

taining the body-temperature during our winter months, is stored up in the system. Freedom from excitement is well recognised as an important factor; nervous, irritable animals cannot fatten, owing to the disturbed state of the system. The expenditure and body-waste which occur during exercise being a direct loss of body-tissue, the necessity of rest for fattening animals is clearly indicated.

The quality of the meat depends upon the distribution and character of the fat deposited in the tissues; some animals store up fat outside the carcase, others in the internal organs.

The guide as to the differences in the character and amount of food required by different animals is the proportion of their internal organs.

For every 100 lbs. of live weight of the ox,  $11\frac{1}{2}$  lbs. are for stomach and contents; whereas for sheep, the number is  $7\frac{1}{2}$  lbs., and for pigs,  $1\frac{1}{3}$  lbs. The intestines and contents with the ox are  $2\frac{3}{4}$  per cent. of his weight; with the sheep  $3\frac{1}{2}$  per cent.; and the pig  $6\frac{1}{4}$  per cent.

From these considerable differences in the proportion of the digestive organs, great differences may naturally be expected to occur in the feeding. The small stomach of the pig is not intended to digest cellulose, whilst that of the ox is; sheep require less cellulose than the ox, and the pig more starch than either, to digest which his intestines are comparatively the largest.

Lawes' and Gilbert's investigations show that the amount of dry substance of food required to produce a given weight is larger with the ox than with the sheep, and larger with the sheep than with the pig.

As an animal passes from the store to the fat condition, it is found that the increase in weight steadily decreases although the same amount of food is consumed.

Both oxen, sheep, and pigs contain from 3 per cent. to 4 per cent. less nitrogen in the fat than in the store condition; whilst, on the other hand, they contain about double the amount of non-nitrogenous substance in the fat than in the store condition. Both the water and salts

diminish as the animal passes from the lean to the fat state.

The dry substance of the food of the ox contains a larger proportion of indigestible matter than that of sheep, and that of sheep more than that of pigs. Oxen require from five to six, and sheep from three to four times as much time to add a given proportion to the weight of their bodies as pigs.

The greater part of the nitrogenous and mineral matter of the food is recovered in the manure, and the greater part of the non-nitrogenous substance is lost by respiration and other exhalations; a much smaller proportion being retained in the increase or voided in the manure. For a given amount of increase produced, oxen void considerably more substance as manure, and expend more in respiration, etc., than sheep, and sheep very much more than pigs. For a given weight of dry substance consumed, oxen void more as manure than sheep, and sheep very much more than pigs; but oxen respire rather less than sheep, and sheep rather less than pigs.

The manurial value of foods is not a hygienic point, but one closely connected with agriculture; practically it is found that if one food yields a richer manure than another it is the cheapest to feed on (though it may be more expensive to buy), for the reason that so much of it is returned again to the soil.

#### *Cattle.*

According to Wolff the first thing with lean oxen intended for fattening is to put their system in good order, by beginning with a diet of somewhat high albuminous ratio, viz. clover hay, barley or bean-meal, and oil-cake.

After two or three weeks the fattening can begin, the albuminoid ratio is lowered by the addition of digestible carbo-hydrates, with the result that the destruction of proteid under the higher nitrogenous diet is suspended; proteid will now be stored up, and shortly fat. Fat can only be put on when the proteid tissues have been previously prepared by extra nourishment and renewal.

After the animals have been on this diet for some time and fat is being stored up, the albuminoid ratio is raised by the addition of proteid. No destruction of fat will result from this extra proteid; on the other hand it will be stored up as fat.

So much for the theory of fattening, we must now consider its practice.

Though the details of fattening oxen and sheep differ widely in the hands of various farmers and graziers, yet there is the most complete consensus of opinion that no animals that have been starved or underfed during their early growth ever fatten satisfactorily. They must not lose their calf or lamb flesh if they are to fatten on a reasonable amount of food, and put the fat on in the right place. The deposition of fat in the internal organs is not what is desired, but its distribution among the skeletal muscles.

Nothing must interfere with the fattening process once it has begun. If the food supply be insufficient even for a day, it will take three times as long to repair the damage done.

The practice of fattening varies with the condition of the animal, the nature of available pasture, the part of the country, and the prejudice of the feeder.

When a man breeds and fattens his own stock the measures are not quite the same as when he goes into the market and buys 'store' cattle. The latter are poor, those of his own rearing if judiciously managed have never lost condition, but have gone on gradually accumulating flesh.

It would be most unwise to treat these two classes as identical for fattening purposes; the animals in better condition can stand a richer pasture and more nutritious feeding than the impoverished 'stores.'

The available pasture may be first-class fattening land or only average. It would be an act of folly to at once bring poor cattle on to rich pastures, depending on his land the judicious grazier buys animals the condition of which warrants them going on good pasture or the reverse, and he gradually brings them on.

It is quite possible on some first-class pastures to trust to grass alone for some time to fatten, or to complete fattening, and there are some rich pastures where two sets of cattle may be fattened in one season. Some graziers buy animals they can get rid of in a few months, others are prepared to keep them for eighteen months, and the methods in these two cases of feeding are obviously different.

Cattle come into the fat market now at a much earlier age than a few years ago. This is secured by good early feeding and never letting them lose their 'calf flesh,' such animals require different treatment from older and poorer cattle purchased for fattening, in which there is no hurry.

The custom of the part of the country is also an influence, the system is not the same everywhere, depending upon local peculiarities. In the Eastern counties it differs from the West of England, and the North, Midland, and South have each their own methods.

The facilities afforded by the farm are also an influence, if home-grown crops can be utilized a saving is effected. If much of the food has to be purchased greater latitude is given to the feeder, and another system pursued.

These facts are mentioned to explain why no hard and fast rules can be adopted, and why no one system is capable of general application.

For convenience of general description we may divide the subject into two heads, 1, the fattening of home-bred stock, that is the stock raised by the farmer; 2, the fattening of purchased cattle.

The *early fattening of cattle* is a matter of recent introduction. A few years ago it was believed that no animal could be properly fattened until it approached maturity, but this is now known to be incorrect, and animals are sent into the market fit for beef at eighteen months to two years' old, with a year's keep saved.

This early fattening can only be attempted with cattle which have been consistently well fed from birth, with animals the daily weight of which has always been increas-

ing, and that have never had a 'set back' through insufficient nourishment. Some of the most successful feeders have been able to show a weekly increase of 8 lbs. in body weight for young bullocks from birth to eighteen months of age, for Show animals the daily increase in weight has been much higher, varying from  $1\frac{1}{2}$  lbs. to 2 lbs. per day of their short life of from two to three years.

In all cases where forced early maturity has been produced, care has been taken to leave the calves with their mothers for some time, six or seven months is the practice in the West of England, during which in addition to milk they receive grass, and after weaning corn, cake, and grass.

There are variations in this system, frequently the calf is weaned after a couple of months and kept going with skim milk, linseed mucilage, a little cake or meal, grass and roots, and later on hay. After a year old there is another course of grass, cake, roots, etc., and the animal is fit for the butcher at two years old.

The summer feeding of animals is comparatively simple; in the autumn they are brought in and fed in yards or boxes, and some feeders turn them out in fine weather, but the home feeding is their source of supply. It is liberal, consisting of hay, roots, cake, meal, and straw.

These animals are generally fed three times a day, but there are some which recommend feeding four times daily, and the results are very good; in all cases only food of the best character is given.

The secret of forcing animals to mature is good food, both natural and artificial, good pastures, the best of crops, sufficient salts in the food, and shelter from the weather.

Purchased animals for fattening do not give such early results, they are often older, have been underfed, and take much more time. The success of the system depends upon the judgment of the buyer. He must purchase cattle suitable for his land, and depending upon their previous condition, and the facilities for fattening them, they can either be turned out as beef in six or twelve months.

There are many grass lands employed entirely for the fattening of cattle ; the latter are bought in the spring of the year, and fattened off during the summer. Whilst at pasture they receive 2 lbs. to 4 lbs. of oil-cake daily, or a certain amount of grain. Care is taken not to overstock the pastures, and the animals are constantly shifted to afford a fresh bite; rich pastures should be reserved for animals full in flesh. Sheep, from biting closer and picking out the sweetest herbage, should not as a rule be pastured with cattle.

To put poor animals on rich pastures at once is a serious mistake, their system must be gradually accustomed to the change in food or disease will result. The owner of good rich grazing would not therefore buy animals in very low condition, but look for something with more flesh on it. With good pastures and suitable cattle, fattening can be carried out in a few months on grass alone with the addition of three or four pounds of cake a day. When the grazing fails they may be finished with hay, meal, cake, and roots.

With impoverished 'store' cattle it is obvious the process of fattening will take longer. If they are purchased in the spring they are turned out on to suitable pastures which renovate their systems, and get them ready for winter finishing off. The management of stock on pastures is not a matter to be neglected, and will be dealt with later (see Pastures).

Soiling is advocated as a more economical means of feeding and fattening, with less destruction of the pastures. The animals should be practically unlimited in the amount given, but no waste should occur if the process is intended to be economical. The green food, when brought home, should not be allowed to lie in a heap, or fermentation will occur. For further details see Soiling.

As the grass fails the stock is gradually drafted into yards or elsewhere for winter feeding, beginning by taking up those in the most advanced condition, and gradually bringing in the others, so that by the end of October all the

animals are in yards, stalls, or boxes, receiving turnips or swedes, oil-cake, hay-chaff, and bean-meal.

If fed in boxes the cattle are given about 100 square feet of standing room, their bedding is not removed so that the floor of the box is two feet or so below the ground level, and on this a small amount of straw is spread over the manure day by day, which is well trodden in by the animal. A compact putrid mass results, invaluable to the farmer in the course of a few months, but unspeakably insanitary.

Yard feeding is preferred in some parts of the country, a shed gives the needful protection from the weather, the manure remains undisturbed but is less objectionable, as with the shed system there is much more air, only one side of the building as a rule being closed in.

In stall feeding the cattle are tied up, generally in pairs, with barely sufficient room to lie down. Their system of feeding is the same as above described, but their manure is received into a channel behind and does not remain under the animals.

It will be observed that in all these systems the farmer is aiming at two results, he wishes to fatten his animals and he wishes for manure. For all intents and purposes cattle undergoing this régime are meat and manure making machines, without the latter it is doubtful whether the former could be made to pay, especially where food is expensive as the result of a bad season.

It is equally certain, however, from a sanitary point of view, that the whole system of animals living on their own excreta is wrong, and that no difficulty should be felt in the present day of labour saving appliances, of saving all the manure, protecting it from loss, and still keeping animals under hygienic conditions. This question will be referred to again later on.

It is quite impossible here to give an account of the system adopted by different feeders in preparing cattle for sale. Each has his own idea of the food required and how it should be divided over the day, and each has his prejudices and fancies.



Here is an example of the actual food requirements for fattening cattle, the experiment having been made by the Royal Agricultural Society at Woburn.

Two lots of four animals all of the same age were taken, the hay and roots were unlimited. The experiment lasted 145 days, and the following was the amount of food consumed per head per day :

	Lot 1.	Lot 2.
	Lbs.	Lbs.
Cotton Cake ... ..	3·3	3·3
Linseed Cake ... ..	2·88	2·88
Barley (grittled) ... ..	4·00	4·00
Roots ... ..	40·00	40·34
Hay Chaff ... ..	8·88	8·88
Water ... ..	36·30	27·61

Lot 1 increased in weight 2·21 lbs. per head per diem ; Lot 2, 1·97 lbs. per head per diem. Lot 2 received un-decorticated cotton cake, Lot 1 decorticated, which is the explanation of the difference in fat stored up.

To produce 100 lbs. increase in live weight with oxen, Lawes and Gilbert found that 250 lbs. oil-cake, 600 lbs. clover chaff, and 3,500 lbs. swedes were required. The amount of each food-constituent stored up for 100 consumed was as follows: nitrogenous matter, 4·1; non-nitrogenous, 7·2; mineral matter, 1·9.

Here is an example of a cattle feeding mixture for show cattle :—

	Lbs.
Crushed oats ... ..	1
„ barley ... ..	1
„ maize meal ... ..	1
„ wheat ... ..	1
Bean or pea meal ... ..	1
Bran ... ..	1
Double handful of sweet chaff.	
Pulped roots ... ..	4

The above is one feed. The stock proprietor\* who

\* Mr. Watson, late of Keillor, *North British Agriculturist*.

adopted this method with remarkable results for Show cattle, fed four times a day, the evening feed being a hot one. This he prepared by taking the above and adding linseed meal 1 lb., molasses 1 pint, to it, pouring boiling water over the mass, avoiding making it sloppy, thoroughly mixing, covering up for four hours, and feeding with it at 8 p.m.

Mr. Watson gives his own table of the amount of digestible food constituents this represents daily, viz. :

					Lbs.
Proteid	...	...	...	...	3.277
Fat	...	...	...	...	1.000
Carbo-hydrate	...	...	...	...	16.00

All his animals were watered four times a day, and in cold weather the chill taken off.

A good daily allowance for winter feeding is

Hay	...	...	...	...	14 to 20 lbs.
Oil-cake	...	...	...	...	3 "
Bean meal	...	...	...	...	3 "
Roots	...	...	...	...	70 to 90 "

But the feeder is not compelled to tie himself down to these articles of diet, there should be a variety of food if obtainable, for example, barley, rye, oats, linseed, pea or bean meal, and such succulent food as cabbage, carrots, parsnips, and turnips. There should also be a judicious mixture, mixed feeding is economical and far better than feeding on one or two particular articles of food to the exclusion of others. The time of feeding must be regular, the amount must be suited to the animal's taste, it should not be in excess or disgust will occur; everything depends upon the powers of observation of those in attendance, who should be able to recognise when to increase and when to decrease the diet, depending on circumstances, for as the animal advances the appetite becomes capricious, and more frequent feeding with smaller quantities may be necessary.

*Sheep.*

The early fattening of sheep, like that of cattle, is now practised, the lambs born at the beginning of the year are as soon as possible got on to powdered cake, and crushed oats, with turnips, kohlrabi, or rape, and later on split peas, the ewes being liberally fed on the same so as to feed the lambs through their mother. Before the grass is fit to receive them the thousand headed kale is a valuable crop; while on grass they are frequently moved from pasture to pasture.

With the autumn they come on to turnips, cabbage, hay-chaff, and corn, and this diet may be maintained during the winter. When the time comes round for swedes to replace turnips, great care must be observed, as these have a decided tendency to cause diarrhoea and throw the animals back. Towards the end cake and corn, from 1 to 1½ lbs. daily, are given, the great object being to get the animals fit for sale in the spring, when a little over a year old.

By forced feeding, lambs at ten months old have been known to show an average daily gain of live weight of three quarters of a pound.

Lawes and Gilbert found that to produce 100 lbs. increase in live weight, sheep required 250 lbs. oil-cake, 300 lbs. clover chaff, and 4,000 lbs. swedes. The animals stored up for every 100 parts of each proximate principle consumed—nitrogenous matter, 4·2; non-nitrogenous, 9·4; mineral matter, 3·1.

In the general feeding of sheep not intended for fattening (and the subject may conveniently be considered here), attention should be paid to the diet in the winter, which should consist of hay, roots, with oil-cake or grain. To feed exclusively on roots, especially during the cold months of the year, is practically a starvation diet, hay or other dry food must always be given with them. As the lambing season approaches the ewes should be generously fed to ensure their milk supply being rich enough; a mixture of cake, oats, and beans, three quarters of a pound of each,

together with 1 lb. hay and green food, will keep their milk in excellent condition after lambing.

Roots should be sliced or pulped, and cake crushed, especially is this the case in those animals where changes in the teeth are occurring.

Sheep should not be at once introduced to rich pastures, but be gradually brought forward. On ordinary pastures care must always be taken to avoid overstocking the land.

*Sheep fed exclusively for Wool* can be kept on very little more than a subsistence diet, in fact a high albuminoid ratio is to be avoided as they store up fat, and experiment clearly proves that no more wool is produced with a fattening diet than on one of bare maintenance.

If the diet falls below this and the animals lose weight, the amount of wool produced falls off.

### *Pigs.*

These are very economical meat and fat producers, and their stomach takes kindly to the most mixed and varied diet. They have a very high digestive coefficient, as may be seen from the following table.

Food.	Proportion Digested for 100 Supplied.			
	Total Organic Matter.	Albuminoids.	Fat.	Soluble Carbo-hydrates.
Sour Milk ... ..	97	96	95	99
Meat Flour ... ..	92	97	87	—
Pea Meal ... ..	91	88	58	97
Bean „ ... ..	84	79	71	91
Barley Mcal ... ..	84	79	70	90
Maize „ ... ..	91	84	76	94
Rye Bran ... ..	67	66	58	75
Potatoes ... ..	94	81	—	98

Though pigs are not too particular as to their diet, yet in feeding for fat production some little care is desirable. Frequent feeding, as the stomach is a small one, is indicated, the amount of food given should be as much as they can

consume. The feeding-troughs must be kept clean; the usual filthy surroundings of the piggery are by no means essential to fattening.

The foods most commonly employed for fattening pigs are barley, maize, pea or bean meal, with potatoes and dairy refuse. German authorities strongly recommend sugar as an addition to the diet. The food should be varied in character as in course of time the appetite becomes fastidious.

The excessive use of maize, it is said, should be avoided as it makes the flesh yellow and flabby, while beans and peas if used in excess cause it to become hard and stringy.

Lawes and Gilbert found that 100 lbs. increase in live weight with pigs was produced by 500 lbs. barley meal. The animal stored up of every 100 parts of the food constituents consumed, 13.5 parts of nitrogenous matters, 18.5 of non-nitrogenous, and 7.3 of mineral substances.

#### FEEDING OF MILCH COWS.

The proper feeding of cows is a most important matter. In collecting the various dietaries recommended by men of experience, it is singular to find so little uniformity. It only shows the success of feeding does not depend upon the details, so much as upon the general principles which are observed.

It is essential the cow should be kept in good condition, but the storing up of fat must be avoided or it would defeat two special objects, viz., milk supply and breeding capabilities. The food given must be wholesome and nutritious; sufficient must be allowed, as bulk is absolutely essential for rumination, but care should be taken, particularly in feeding with grains, that no excess is given or it will pall on the palate. Stinting must therefore be practised with regard to the most favourite foods.

Feeding at regular hours is essential, otherwise the animals are kept in a restless condition, and the supply of milk will be affected; not only should regularity be observed in feeding, but also in milking and watering.

Exposure to cold should be avoided, as a decrease in the yield of milk will at once occur. But this does not mean the animals should be poisoned with the products from their lungs; ventilation and pure air are necessary, if the temperature falls too low artificial heating should if possible be adopted.

The routine of feeding will vary nearly everywhere. For winter feeding in London dairies the cows are given, usually after the early morning milking,  $\frac{3}{4}$  bushel of grains, followed by about  $4\frac{1}{2}$  lbs. of hay. About nine o'clock they receive 30 lbs. of sliced or pulped mangels, (if the latter, they are usually mixed with chaff, if the former, another  $4\frac{1}{2}$  lbs. hay are given), and the animals left undisturbed. About two o'clock they receive another  $\frac{3}{4}$  bushel of grains, followed by  $4\frac{1}{2}$  lbs. hay. At five o'clock they are watered, it being usual to only water them once in twenty-four hours; in the evening they receive another  $4\frac{1}{2}$  lbs. hay, and are then left for the night. In some places 2 lbs or 3 lbs. of crushed oil-cake are given daily in addition to this diet.

Distillers' grains are more valued than brewers' grains for milk production. Their actual effect on this secretion is to increase the proportion of water, the milk is, therefore, poorer in solids. It is said that the milk of cows fed on grains 'turns' readily, however this may be, grains are considered a very important article in the London dairy (see Grains).

The summer feeding is principally artificial grasses and grains, with a proportion of oil-cake. About 1 cwt. of green grass is given.

This system of feeding is by no means adopted everywhere, each dairy-man has his own views on the subject; still the outline given is what actually occurs in some of the largest dairies.

The production of milk is not, however, confined to towns and cities, it has now become an important industry miles away from the place where it is consumed, and the management of dairy stock in the country and in cities is obviously different.

For summer feeding good sheltered pastures are desirable, so situated that the animals have no distance to go before reaching their sheds, and where they are free from interruption and shaded from the sun. There are some who prefer to keep their cows housed during the day and turned out at night, and others who keep them out continuously so long as the weather is suitable.

During the summer they may be grazed or soiled according to convenience. There is nothing like grass for improving milk, but it is desirable to give in addition daily a certain amount of linseed cake or crushed beans, three or four pounds of either, bearing in mind the great drain on the system which heavy lactation represents; it may in fact be regarded as equivalent to a daily blood-letting. Other green food than grass can also be given, such as clover, vetches, or tares, though the latter is not generally cared for as it is considered to render milk 'ropy.'

For winter keep hay, roots, cake, beans, or peas are used; cabbage and turnips give a taste to milk, but are otherwise good articles of diet. For methods of preventing them tainting milk see 'Roots.'

In the winter feeding, linseed prepared by boiling is frequently given in place of cake, and this is the practice of a large dairy company, which allows each cow 1 lb. linseed during the winter and  $\frac{1}{2}$  lb. during the summer, the mucilage being poured over the food. In addition the cows receive 5 lbs. to 6 lbs. of crushed oats, and 1 lb. of any other meal daily, besides hay-chaff, roots, and occasionally silage.

In the use of silage it should be borne in mind that its presence in the milking shed may easily impart a taste to milk, which of all fluids is one that most readily takes up any smell in its vicinity.

The production of milk represents, as we have said, a great drain on the system of some of its most valuable constituents. It is the proteid tissues of the mammary gland which supply both the proteid and fat found in milk; milk is simply the product of the liquefaction of the cells of the gland, so that

the influence of diet on the quantity and quality of milk is considerable.

The essential constituent in the diet of cows is proteid, if this is too low not only does the amount of milk produced fall off but its quality suffers. The difference between a diet rich in proteid and one poor in it may cause a falling off of from 20 per cent. to 40 per cent. in the supply of milk.

Wolff puts the daily diet of a milch cow at

				Lbs.	Oz.
Digestible Proteid	...	...	...	2	8
„ Carbo-hydrates	...	...	...	13	8
„ Fats	...	...	...	0	7

The albuminoid ratio being 1 : 5.4.

This amount can be provided by the following, which may be taken as a sample of many diets in use :

					Lbs.
Hay	...	...	...	...	12
Oat Straw	...	...	...	...	4
Mangels	...	...	...	...	30
Grains	...	...	...	...	30
Cake	...	...	...	...	2.5

The food most favourable for milk production is oats, while more nitrogen if necessary can be supplied by linseed or cotton cake, peas, beans, etc. Green food is an admirable diet, while brewers' or distillers' grains, as previously mentioned, will greatly increase the actual yield, but not the quality.

Diet has a marked effect on the butter; linseed cake produces a soft oily butter, peas a hard butter, while turnips impart a flavour and bitter taste. With a diet poor in nitrogen the butter may be as hard as tallow and without flavour.

*The feeding of dry cows* is a matter which the intelligent farmer needs no advice about, but there is a feeling among some that her diet may be mere subsistence, whereas it is economical to feed her well, hay and cake during the winter, with roots, bearing in mind she is only being prepared for



the work before her, and further that the foetus requires nourishment if its life is to be preserved.

### *Feeding of Calves.*

There are two distinct methods of rearing calves, viz., the natural and artificial.

Dealing with the latter, this system is adopted in order to secure the milk, and a variety of methods good and bad are employed by farmers in order to bring up their calves on artificial food.

Artificial feeding is always a difficult matter, and until within the last few years no serious attempt had been made to give the calf a mixture which in any degree resembled its mother's milk, yet the composition of this would naturally form a guide to the animal's requirements.

Here is an outline of the system generally adopted.

Calves are usually reared by hand; the custom is to remove them from the mother at once, and they receive her milk until it is fit for use. Their diet is new milk for three or four weeks, of which they require about one quart three times a day; later they receive skim-milk warmed up and mixed with some easily digestible food. Calf meal, which may be anything, is often given; unless the composition of the meal is known, it would be better to trust to oatmeal, linseed gruel, or cake-dust. The cooking of these substances should be carefully observed. Skim-milk being deficient in fat, the food supplied must meet the loss, and this can be effected with boiled linseed.

The feeding of calves should be regular and not less than *four* times a day. It neither pays to starve nor neglect them if they are to be made profitable in the future.

Later on the calf may be tried with a little hay, grated turnips and swedes, grass if obtainable and cake-dust, and this may be attempted at five weeks old. In the meantime the animal should be still receiving either a milk diet or a milk substitute, such as oatmeal and linseed with skim milk, the whole heated to blood-heat for the calf to take from the pail.

Later, as the grass becomes available their stomachs should be prepared for it, as sudden changes in diet are to be avoided. At three months of age ground oil-cake, and crushed oats and bran in the form of a mash, may be given, and by the time the calf has settled to this diet and is thriving, the milk or milk substitute may be stopped, say at four months old. From now the animal, if strong, may remain permanently on a dry diet.

This purely artificial method of rearing calves is the outcome of practical experience, the cow is a milk-making machine, anything which reduces the supply is financially a loss. The above method of rearing calves is to avoid as far as possible reducing the secretion of milk, and practical experience warrants the custom. It does not apply to pedigree stock, the calves of which are brought up under natural conditions.

There are many milk substitutes:—

Hay-tea and linseed-mucilage; linseed-mucilage and skim-milk; skim-milk, linseed-cake, and treacle; wheat flour and skim-milk; hay-tea and skim-milk; gruel (bean or oatmeal) and butter-milk; oatmeal, linseed, and skim-milk.

In all cases these substitutes are prepared by thorough cooking, and given to the calves at blood-heat; this is a most important point to attend to. It will be observed how prominently skim-milk figures in these milk substitutes.

The most successful milk substitute is obtained from separated milk, by which no delay occurs in removing the fat, the cream being replaced by linseed, and the whole given at body-heat. Milk treated as above is only deficient in fat, which is replaced by the linseed, the other solids practically remain unaffected.

There appears a consensus of opinion that at least one form of diarrhoea from which the calf suffers, (not 'White Scour') is due to the milk substitutes being given at varying temperatures, or to their imperfect preparation, or to acidity in the mixture caused by dirty vessels setting up fermentation.

## THE PRINCIPLES OF FEEDING.\*

The principles which govern the feeding of horses must now be reviewed. No attempt can be made to deal with the matter in detail, we can only glance at the general principles involved.

Looking at the matter from a plain practical point of view, a horse must be considered as a machine, out of which it is desired to obtain the greatest amount of work at the smallest expense and the least risk; in the same way as a cow may be regarded as a milk-making and breeding machine; oxen as meat-makers; sheep as wool, tallow, and mutton makers; pigs as bacon and ham produces.

The food given must meet several requirements; it must be wholesome, abundant, clean and sweet, the hours of feeding regular, and the quantity given should be proportional to the arrangements of the viscera. The mode of preparation found by practical experience to be the best must be adhered to, and cleanliness in preparation and administration should be observed.

There are certain physiological conditions connected with digestion in the horse which have their hygienic aspect, and these must first be briefly considered.

The stomach of the horse is very small; an organ of average size will contain roughly half a cubic foot of material, and it does its work best when it is two-thirds full. In estimating the amount of material this represents, it must not be forgotten that hay takes up four times its weight of saliva, oats rather more than its own weight, and green grass half its weight. Thus considerable additions of saliva have to be borne in mind, as they greatly add to the burden of the stomach.

\* This section relates entirely to the principles involved in the feeding of horses. Cattle and sheep have been fully dealt with in the preceding pages.

The feeding of horses is such a very special matter, and so intimately connected with the production of disease or the preservation of health, that no excuse need be made for giving it further consideration, even if it involves some repetition.

The length of time occupied during stomach digestion is generally in proportion to the amount of nitrogen contained in the food; thus hay and straw pass out of the stomach more rapidly than oats. If hay be given before oats, it is found that in the stomach they are arranged in the order of their arrival; namely, the hay occupies the greater and the oats the lesser curvature, and there is no mixing of the foods excepting at the pylorus, the line of demarcation between the two being very sharp.

If oats be given before hay, the former is deposited in the greater and the latter in the lesser curvature of the stomach, and the foods remain distinct excepting at the pylorus.

Hay is invariably found during the early part of digestion to pass out of the stomach quicker than oats; but towards the end of the process the oats pass out more quickly than hay, which appears to remain behind as ballast, and may not enter the intestines for six or eight hours.

According to Colin's experiments, hay given after oats causes the latter to be sent into the intestines before being fully acted on in the stomach; he argues, therefore, that the logical method is to give hay first and then the corn ration.

Although the food arranges itself in layers in the stomach, in the order in which it arrives, yet these layers can be broken up by the ingestion of a large quantity of water, which at the same time carries into the intestines portions of food unfit for intestinal digestion. Water given in small quantities does not disturb this arrangement of layers.

In feeding with a mixture of foods such as chaff, maize, corn, etc., it is found that in the stomach the different foods still remain mixed, and pass into the intestines together.

The stomach begins to empty itself very early after the commencement of a meal; as soon as the viscus has attained a certain volume material passes out, and the

amount so passing corresponds with the quantity being eaten, so that its capacity remains the same. From this we learn the fact that a 'feed' should be small in bulk, otherwise ingesta is sent into the intestines before being properly prepared.

When the 'feed' is finished the passage of material into the small intestines slackens considerably, and in course of time becomes so feeble that several hours will elapse before the stomach completely empties itself. The drier the contents of the stomach the greater difficulty is there in it passing the pylorus.

The rate of stomach digestion is an interesting problem, what really occurs is that there appears to be no fixed period. With an ordinary 'feed' of oats or hay half of it will have passed the pylorus during the first hour, but the remaining half may be several hours in completing the passage, though if the animal be again fed the remains of the last 'feed' at once pass out of the stomach.

The feeding of horses is determined by the nature of their work, and the velocity with which this is performed must also regulate the bulk of food they receive. It is evident that severe labour cannot be performed on a full stomach, for the pressure exerted on the diaphragm, and the interference with the process of digestion, will certainly occasion disease. It is also clear that the greater part of the food required by hard-working horses should be of a concentrated kind, such as the various grains. Even the hay should be chaffed to economise the time of the animal in mastication.

The smallness of the stomach points to frequent feeding and in small quantities; the great capacity for water and the small stomach, explain the golden rule of experience that watering before feeding should be invariable.

The fermentable nature of the food points to the necessity for due mastication and proper admixture with saliva. The general inability to vomit more than warns us of the great danger to which the animal is exposed should stomach derangement occur. The remarkable sympathy existing

between the digestive organs, the skin, feet, nervous, lymphatic, and urinary systems, shows us how many diseases of quite an opposite character may be dependent on the food given; in this connection may be mentioned broken wind, laminitis, diabetes, lymphangitis, azoturia, congestion of the brain, diarrhœa, etc.

Horses performing slow work are necessarily dieted differently from those performing fast work. Work of a laborious nature, be it in the hunting-field or between the shafts of a heavy cart, cannot be performed on a full stomach, or distress is rapidly brought about by the pressure of the stomach against the diaphragm, and the consequent obstruction to the free action of the lungs. If urged beyond this, rupture of the diaphragm or stomach may be produced. During fast work the stomach should practically be empty; horses should, therefore, be fed one or two hours before they are required, and the food given should be of a concentrated character, such as oats.

With slow or moderate work the same extreme care need not be exercised with regard to abstinence before going out, but even here a distended stomach may prove dangerous, especially for animals performing draught work.

Work should not be too prolonged or exhaustion soon occurs; after severe work the appetite must be tempted, especially as very often all ordinary food is refused. Warm gruel may be given and a good bed provided, for frequently the appetite does not return until after a thorough rest.

The influence of work on the production of colic is extraordinary. One can only account for it by saying that work interferes in some way with normal digestion, possibly from some breach of the rules of feeding which we are now discussing.

After prolonged abstinence feeding in small quantities should be observed, the ravenous feeding of a hungry horse has caused many cases of colic, and more serious stomach trouble. Ravenous and greedy feeding may be natural to an animal apart from hunger, such cases should be carefully controlled, on no account, if it can be avoided, should

they be fed from a nose-bag. Their food should be placed on a level surface, such as the lid of a box, and spread out in a thin layer with the hand. This quite defeats the horse that bolts its food.

To ensure thorough mastication of grain, it should always be mixed with chaff, which should be damped to prevent it separating from the corn. Chaff added to corn in sufficient quantity will also control greedy feeding.

Gorging may also occur from greediness, and in the days when large feeds were placed before horses 'gorged stomach' with its attending brain trouble was very common. Veterinary science has practically banished this disease out of existence.

Regularity in feeding, and regular but not excessive work, are the two chief measures for controlling dietetic diseases. Horses should be fed three or if possible four times a day in small quantities at a time. The hay ration should not be given before work, the bulk of it should be reserved for night time, as it gives the horses something to do and keeps them quiet; further, it is of course hygienically a sound measure.

The feeding of horses four times a day and the bulk of the hay ration at night, are remarks intended to apply to saddle and carriage horses, and not to the regular working horse of commerce, which we have seen is fed at every available opportunity. These latter need at night all the rest they can secure, the longer they are off their legs the longer they will last.

In connection with this point, it may be mentioned that the ordinary horse requires very little sleep, and that his natural habit is to prefer a series of broken rests, during the intervals of which he will always eat if anything is available.

It is impossible to keep up vigour and condition on concentrated foods alone, a certain amount of bulk is needed by the bowels for the due performance of digestion, without it the horse becomes 'tucked up,' and Stewart believed it to be a common cause of 'wind-sucking' and 'cribbiting.'

It is said that heavy horses will not look well on less than 29 lbs. of food daily. A certain amount of hay appears essential, concentrated foods, such as have been suggested for army horses, can only be a make-shift ration.

If a horse be allowed an unlimited amount of grain the hay consumed becomes reduced in amount; but unlimited corn and no hay very soon shows itself.

Though the food under favourable conditions only remains in the stomach a few hours, on the contrary it remains in the intestines for several days; practically never less than four, and often a day or two longer. During the greater part of this time it is lying in the large intestines, for the passage through the small bowels only occupies a few hours.

Horses at work the greater part of the day are fed as opportunity offers, little and often is the secret of keeping them in condition. This is perfectly understood by the carman and cabman, who never hesitate to put on the nosebag as opportunity occurs.

Hard-working animals must be saved as much time as possible in mastication; this apart from its economical advantage is one reason for the use of chaff. No person who is not wealthy can afford to feed his horses on long hay, owing to the waste. Every commercial firm in the kingdom uses chaff instead of long hay, and they reap a triple advantage, they save one-quarter of their hay, they ensure the thorough mastication of the grain ration, and save their horses time and energy in consuming it.

Zuntz and Lehmann found with horses that 11·2 per cent. of the energy obtainable from hay was expended in masticating it, while only 2·8 per cent. was expended in masticating oats.\* This argues not only in favour of chaff, but of it being cut short.

The length of time it takes a horse to consume its daily diet is a question which seldom strikes anyone to enquire into, yet it is of the utmost importance, especially for horses employed in commerce and military life. It takes a horse

\* Wolff, *op. cit.*



from five to ten minutes to eat one pound of corn and fifteen to twenty minutes to eat one pound of hay. We shall not be far from the truth in saying that they require from five to six hours out of every twenty-four for feeding, that is to say, one quarter of the day must be expended in taking in sufficient nourishment for the repair of the machine. We see here the wisdom of the carter and cabman, who put on the nosebag at every available opportunity.

Sudden changes of diet should be avoided ; horses fresh from grass must be gradually brought on to the usual stable food. In the same way animals which are intended to be 'turned out,' should have their corn ration reduced and replaced by succulent herbage.

The necessity of increasing or reducing the corn ration to correspond with the work performed is another point of practical importance ; beans added to oats will produce the most highly nitrogenous diet a horse can assimilate. Where a reduction in diet is required, mashes of bran are substituted for the whole or part of the corn ration.

One sound system the result of experience, is giving highly-fed and hard-worked horses nothing but a bran mash on Saturday night, and this diet, with hay, might well be continued until the evening feed on Sunday.

It is the secret of preventing, among draught horses especially, lymphangitis and azoturia, and further, even if these diseases are not threatened, it gives the stomach a needful rest and keeps the bowels in order.

The conformation of a horse affects in no slight degree its capacity for assimilating food. Animals with narrow chests, badly 'ribbed up,' and of a light mealy colour, are notoriously 'bad doers' ; they never look well, are prone to derangement of the digestive organs, purge on the slightest provocation, and are generally known amongst horsemen as 'washy.' They require careful dieting ; new oats or hay should never be given them, their work should be light, and they must not be worked soon after feeding. In winter their water must have the chill taken off, the body should

be kept warm, crushed oats may be found advantageous, but with every care it is often a matter of extreme difficulty to either get the work out of them, or make them presentable in appearance.

Linseed is never necessary for a horse in health, though it is frequently given to improve the skin and coat. It is far too fattening to be used frequently; working horses should not be fat, and linseed should be reserved as a hospital diet, or for those out of condition, and as an occasional change in food if such is considered necessary.

In winter it might be employed for horses leading a very exposed life, to supply more fuel for body-heat. In the form of linseed-oil poured over the food we have no opinion of its utility.

In the management of all horses, especially those used for commercial purposes, constant supervision over the feeding arrangements is necessary; the forage should be inspected regularly, surprise visits paid to the stable, measures checked and verified, mangers, nosebags, and machinery looked into, even the fæces examined, and if necessary washed for the purpose of inspection. A complete police system is required, the smallest defective point if gone into may be the means of revealing the most astonishing irregularities.

Every man should know what his horse is entitled to receive, and amongst the stable instructions the diet sheet should be prominent.

These details and precautions, even what may appear to be the most trifling and insignificant, are of the highest possible importance. Where forage is concerned nothing but the eye of the person most interested will prevent fraud.

In the stables of the wealthy the same supervision is needed but never given; the horses are crammed with food, but they could not possibly eat all their master pays for. If he is content to be robbed through ignorance or indifference on his own part, that is a matter which concerns him alone, but it is otherwise with public companies, or horses the property of the State.

An account of the diets required for working horses will be found in detail on p. 118.

*The feeding of pregnant mares* depends upon whether they are at work or not. The common practice with farm mares is to work them up to near the end of gestation, and provided the work towards the end, viz., the last three months, is not severe, there can be no doubt the practice is sound. In regular breeding establishments where the mares are absolutely idle, it is evident the food requirements are different.

A working in-foal mare should be fed liberally, but very bulky food is objectionable. Hay should be given in moderation, oats and a few beans are necessary, linseed occasionally, and bran liberally. Maize as a food for any of the pregnant herbivora is a mistake, as it is very deficient in salts.

Care should be taken to carefully regulate the mare's work, and water and feed her with great regularity, as an attack of colic at such a time might prove disastrous.

For idle mares the diet should be less stimulating, but they must not be starved; the usual foods may be employed depending on the time of year, but with a liberal amount of bran in order to keep the bowels in proper order.

In both cases it is desirable when indications of approaching parturition are apparent, to get the bowels in good order with bran mashes, which should represent the chief article of diet about the expected day of foaling.

After foaling the mare may be fed more liberally, for the first few days with care, then gradually increased as all risk of complications is past.

*Foals* are weaned about the fifth or sixth month, up to this time they require little else than the mare's milk, but from now the diet should consist of grass, hay, and corn. The principle of feeding foals may be shortly summed up—give them as much as they care to eat. The general feeling on the subject is to give as much as will support life, and but little more. The absurdity of such a system cannot too freely be condemned; if the foal be underfed, it is

impossible that it can ever grow into anything but a long-legged, narrow-chested, light-bodied weed, utterly useless for any purpose. No better example can be followed in the matter of feeding foals than that set by the breeder of blood stock. The effects of liberal feeding are here wonderfully shown; a two-year-old thoroughbred horse is as fully furnished as a half-bred one is at four or five years of age; nothing but good feeding has produced this.

#### CALCULATION OF DIETS.

The following table gives the composition of all ordinary articles of diet, and admits of the digestible constituents being calculated. One or two examples of its working may here be given.

*Example i.*—How much proteid matter is contained in 12 lbs. of the best meadow hay?

$$11.7 \times 12 = 140.4 \div 100 = 1.404 \text{ lbs.}$$

*Example ii.*—How much of the proteid matter in 12 lbs. of the best meadow hay is digestible?

$$7.4 \times 12 = 88.8 \div 100 = .888 \text{ lb.}$$

*Example iii.*—How much proteid matter can a cow obtain from 30 lbs. mangels?

$$1.1 \times 30 = 33.0 \div 100 = .33 \text{ lb.}$$

*Example iv.*—How much of the cellulose in wheat straw is digestible?

$$22 \text{ per cent.}$$

#### *Table for Calculating Diets.*

This table gives the average percentage composition of ordinary food-stuffs, also the percentage of each constituent digested.\*

\* In this table, which is compiled from Wolff, the crude albumen represents the total nitrogen-containing substances in the food.

The crude fibre in the first half of the table represents both cellulose and lignin, in the second half of the table it represents pure cellulose only.

The nitrogen-free extract represents every substance not containing nitrogen other than cellulose and fat.

Food-stuffs.	Total Percentage Composition.						Percentage Digestible.			
	Water.	Ash.	Crude Albumen.	Crude Fibre.	Nitrogen-free Extract.	Crude Fat.	Albumenoids and Amides.	Crude Fibre.	Nitrogen-free Extract.	Fat.
<i>Green Grass :</i>										
Grass just before blossom ... ..	75.0	2.1	3.0	6.0	13.1	0.8	2.0	3.9	9.1	0.4
Red Clover before blossom ... ..	83.0	1.5	3.3	4.5	7.0	0.7	2.3	2.5	4.9	0.5
Red Clover (full bloom)	80.4	1.3	3.0	5.8	8.9	0.6	1.7	2.9	5.8	0.4
Lucerne (quite young)	81.0	1.7	4.5	5.0	7.2	0.6	3.5	2.2	5.1	0.3
„ (just in bloom)	74.0	2.0	4.5	9.5	9.2	0.8	3.2	3.7	5.4	0.3
<i>Hay :</i>										
Meadow Hay (very good)	15.0	7.0	11.7	21.9	41.6	2.8	7.4	13.8	27.9	1.3
„ „ (average)	14.3	6.2	9.7	26.3	41.4	2.5	5.4	15.0	25.7	1.0
Red Clover Hay (full bloom, excellent quality) ... ..	16.5	7.0	15.3	22.2	35.8	3.2	10.7	11.0	26.8	2.1
Lucerne (very good) ... ..	16.5	6.8	16.0	26.6	31.6	2.5	12.3	11.4	22.1	1.2
Vetch (very good) ... ..	16.7	9.3	19.8	23.4	28.5	2.3	15.1	12.6	18.5	1.4
<i>Straw :</i>										
Wheat ... ..	14.3	4.6	3.0	40.0	36.9	1.2	0.8	22.0	13.6	0.4
Rye ... ..	14.3	4.1	3.0	44.0	33.3	1.3	0.8	24.2	12.3	0.4
Oat ... ..	14.3	4.0	4.0	39.5	36.3	2.0	1.4	23.4	16.7	0.7
Barley ... ..	14.3	5.5	3.3	43.0	22.5	1.4	0.8	21.5	9.9	0.4
Bean ... ..	16.0	4.6	10.2	34.0	34.2	1.0	5.0	14.2	20.9	0.5
<i>Grain :</i>										
Oats ... ..	12.4	3.0	10.4	11.2	57.8	5.2	8.0	2.2	42.5	4.3
Barley ... ..	14.0	2.7	10.0	4.9	66.1	2.3	7.7	1.5	56.1	2.3
Beans ... ..	14.4	3.2	25.0	6.9	48.9	1.6	22.0	5.0	45.0	1.4
Maize ... ..	12.7	1.6	10.1	2.3	68.6	4.7	8.0	1.1	67.5	4.0
Peas ... ..	14.4	2.7	22.6	5.4	53.0	1.9	20.1	3.5	49.5	1.4
Rice ... ..	14.0	0.5	7.7	2.2	75.2	0.4	6.9	1.1	71.6	0.3
Linseed ... ..	12.3	3.4	20.5	7.2	19.6	37.0	20.1	6.5	12.4	35.2
<i>By-products :</i>										
Bran ... ..	13.6	5.6	13.6	8.9	54.9	3.4	10.6	2.1	42.3	2.4
Brewers' grains (fresh)	76.1	1.1	5.3	3.9	12.9	1.5	3.9	1.6	8.3	1.3
<i>By-products from Oil Factories :</i>										
Linseed Cake ... ..	11.8	7.3	28.7	9.4	32.1	10.7	24.7	4.1	25.7	9.6
Cotton „ „	10.6	7.2	24.7	24.9	26.0	6.6	18.0	5.7	12.0	5.9
„ „ (decorticated) ... ..	8.9	7.2	43.6	5.7	19.7	14.9	36.9	—	18.7	13.1
Rape Cake ... ..	10.4	7.7	30.7	11.3	30.1	9.8	24.9	0.9	22.9	7.6
Earthnut Cake ... ..	9.8	6.9	31.0	22.7	20.7	8.9	24.8	3.5	15.5	7.2
<i>Roots and Tubers :</i>										
Mangels ... ..	88.0	0.8	1.1	0.9	9.1	0.1	1.1	0.9	9.1	0.1
Potatoes ... ..	75.0	0.9	2.1	1.1	20.7	0.2	2.1	1.1	20.7	0.2
Kohl Rabi ... ..	88.2	1.0	2.3	1.5	6.9	0.1	2.3	1.5	6.9	0.1
Swede ... ..	87.0	1.0	1.3	1.1	9.5	0.1	1.3	1.1	9.5	0.1
Carrots ... ..	85.0	0.9	1.4	1.7	10.8	0.2	1.4	1.7	10.8	0.2
Turnips ... ..	92.0	0.7	1.1	0.8	5.3	0.1	1.1	0.8	5.3	0.1

## DISEASES CONNECTED WITH FOOD.

There is a large and important class of disease recognised as being due directly or indirectly to dietetic errors. It is one of the branches of preventive medicine where the profession has been able to practically demonstrate its usefulness to the public. There is much valuable work done which passes wholly unrecognised, for the reason that it does not appeal to the layman, but in the matter of feeding animals on a rational basis and preventing disease, the pocket is directly touched and a hearing and recognition at once obtained.

The late Mr. Hunting of Durham worked out years ago the problem of feeding large bodies of horses on a rational basis. His principles were based on common sense, a knowledge of digestive requirements, of the chemistry of food, and the market price of produce. Following on his lines, nearly all large bodies of horses employed in commercial undertakings throughout the kingdom are now fed.

To successfully feed horses it is necessary to understand their physiological requirements and their anatomical peculiarities; to have a knowledge of the chemistry of food, to understand the processes of digestion and assimilation; to be able, as only the trained eye can, to recognise at the earliest moment deterioration or improvement in condition; to recognise the influence of work on condition, and the influence of food on work; to understand the class of food best suited to the class of work, and the amount required by individual animals; in a word, someone is required to express for the horse what it cannot express for itself, and that person is the veterinary surgeon.

Some of the largest firms in the kingdom are now leaving the entire feeding and management of their horses in the hands of the veterinary profession, the results have appealed to the pockets of shareholders and ratepayers, and obtained that recognition which is so hard to get unless they can be expressed in pounds, shillings, and pence.

There is probably no factor in the whole list of disease-producing causes so fruitful of trouble as errors in feeding. This is not difficult to understand when an animal cannot express its requirements, and where men feed them with as little discretion as they feed themselves.

Further, in the search for disease-producing causes, there is hardly anything so obvious to the trained mind as bad food or errors in feeding, they can be demonstrated to the layman, and good results at once obtained on their being rectified.

The very nature of the food of herbivora points to the liability to trouble. Vegetable food is prone to undergo fermentation in the digestive canal, much more likely than when the diet is purely an animal or a mixed one. The words colic and horse appear to be held together by a bond, which it has been the duty of the profession to prove can be very largely destroyed by care and management in feeding.

Not only is a vegetable diet a fermentable one, but it must also be remembered that feeding on grain is a purely artificial condition. Herbivora were intended to feed on grass and not on hay and corn; the introduction of corn into their interior is not a natural state of things; in fact, their feeding is as artificial as their existence, hence the reason why digestive troubles are so frequent.

If the life of the horse is artificial, what term can we employ to represent that of oxen, cows, sheep, and pigs? Can anything be more repulsive than the Fat Show at Islington? We have previously described the methods by which this condition of obesity is obtained, the absolute freedom from excitement, repose, rich and unlimited food, and no stone left unturned to stimulate the jaded palate! Nearly the same thing is produced amongst a certain class of horse, fat being mistaken for condition, whereas it is its physiological antithesis.

What we have been endeavouring to show is that the large class of digestive trouble met with among the domesticated animals is the result of ignorance, and the

artificial conditions under which they live. Some of the artificial conditions are necessary and with care harmless, while at least one is the outcome of the most powerful factor in the civilized or uncivilized world, viz., fashion.

The diseases connected with food group themselves under the following heads :—

Alterations in Quantity.

Conditions of Digestibility and Assimilation.

Conditions of Quality.

*Alterations in Quantity.*

It is rather a remarkable, though easily understood fact, that very little of the happy mean exists in the feeding of horses ; they are either underfed and overworked, or overfed and underworked. Which it is to be depends upon the purse of the owner and the class of horse. It is only in business and commercial undertakings, where the question of feeding large numbers of horses causes the matter to be inquired into, that the food supply is not less than nor greatly in excess of requirements.

Excluding entirely from consideration racehorses and hunters, it may generally be said that the horses of all people of means are overfed. There is a constant desire on the part of those in charge to cram them with food, in order to produce that rotundity of barrel and sleekness of coat so pleasing to the eye.

The racehorse and hunter represent another artificial class, which cannot be too highly fed ; immense muscular effort is required, and this can only be met by unlimited food given with sound knowledge and discretion.

The army horse at home is well fed for the amount of work expected ; it does not err on the side of extravagance excepting in one respect, and that is feeding on long hay instead of chaff.

In India the diet of the horse used for military purposes is often seriously defective, and quite unsuited to the climate. What would English horse owners think if they had to feed



their animals entirely on beans or peas! This is the condition existing in some districts, due to the fact that there is no other grain available in sufficient quantity; but the case is an ideal one for a mixed diet, as beans and peas are excessively nitrogenous, and greatly deficient in carbon.

An excess of food leads as a physiological result to a deposition of fat in various parts of the body; as a pathological result it may produce a febrile condition, with liver and blood derangement, especially when the excess is due to proteid.

In the intestinal canal the excess of food may be got rid of by diarrhoea, or it may lie in the digestive tract and ferment, producing toxins which possibly are responsible for the disordered condition of the blood, and the inflammation of the lymphatic vessels of the limbs, conditions which especially occur among the overfed heavier breeds of horse.

Diarrhoea is by far the most favourable condition to be present, the excess is eliminated, and the animal's temperature falls. But the excess may be stored up in the bowels, producing obstinate constipation, with its attendant pain. This may be greatly aggravated by tympany the result of gas generated during the putrefactive processes.

In poisoning by excess of proteid the fœtor of the dejections may be intolerable, while the urine is coffee-coloured, and contains an excess of urea.

But perhaps the most remarkable condition produced is that known as Azoturia, where the animal drops from sudden paralysis of the hind-quarters, with a blood-coloured urine due to methæmoglobin, showing the profound changes which are occurring in the red cells as the result of an excess of proteid in the system.

An excess of starches and fats produces much less urgent symptoms; the pampered carriage horse is a good type of the class, fat deposited in every available place, heart, abdomen and subcutaneously, with a friable liver and fatty heart muscle, due to nothing else but excess of food and too little work. This though a pathological condition in

the horse, is aimed at in the case of oxen, sheep, and pigs.

Excess of food, quite apart from the conditions mentioned, predisposes to certain diseases. It is the fattest horses which are first attacked by anthrax, the poorer animals may entirely escape; it is the oxen brought suddenly from poor to rich pastures which may contract symptomatic anthrax. It is the fat horse that suffers from laminitis, pneumonia, and pulmonary apoplexy,—not entirely because he is fat, but because he cannot be fat and ‘in condition.’

Overfeeding, as we have indicated, may be limited to one food constituent, proteid, fat, or starch; but apart from this overfeeding may be confined to one particular food. Take for example ‘green food’ obtainable at certain times of the year, and of which the dry fed horse or ox is necessarily inordinately fond. If not given with discretion, mixed with hay, or only small quantities allowed to begin with, nothing is more common than stomach and intestinal trouble. Both animals will suffer from tympanites and intense pain, frequently followed in the horse by actual rupture of the viscera from the evolution of gas, or even asphyxia from the pressure exerted on the lungs.

*Deficiency of Food* very early shows itself; theoretically the deficiency may be in any of the proximate principles, viz., proteids, fats, carbo-hydrates or salts, practically it is found the deficiency extends to all the food elements.

It can be ascertained experimentally that the deficiency of starch is better withstood than that of fat, and fat better than proteid, but as we have shown all of these are required in a properly balanced diet, and cannot be done without, though the absence of proteid is felt much earlier than either of the other principles.

When animals are gradually starved it may be brought about by two conditions, either insufficient food, or insufficient food for the amount of work performed. Inasmuch as horses are not kept to look at, these two conditions are generally combined, but it is useful to bear in mind the enormous influence of work on insufficient food.

It is the nervous system which suffers before the muscular in acute cases of starvation or semi-starvation ; there is languor and extreme muscular weakness some time before the muscles show any serious reduction in bulk ; but when presently both the stored up fat and muscles are being utilized for the body requirements, the loss of condition is very rapid, the animal 'melts away,' and if this be continued for many days—the number varying entirely with the previous state of health or condition—the horse is reduced to a pitiable plight, haggard, worn, anxious expression, 'tucked up,' so weak that he can almost be pushed over with the hand, and the prostration so great that should he fall he has not the strength to rise.

It is only in military service, and in time of war, when the condition described is likely to be met. It is not necessary that all cases of semi-starvation should be associated with such urgent and rapid symptoms. It is entirely a question of the amount of work the animal is called upon to perform on insufficient food. The loss of flesh may be gradual, to the untrained eye at first imperceptible, but as this continues there is a gradual look of unthriftiness, a harsh feel of the skin, the faces become small and very often hard, the muscles of the quarters, neck, and shoulders waste, the abdomen 'tucked up,' and later on the haggard expression of countenance.

When horses are suffering from a general deficiency of food, there are certain diseases which very early claim them, viz., glanders or farcy, and mange. The system possesses no powers of resistance, and these diseases are then capable of spreading with remarkable rapidity. Just as the organism of anthrax prefers and seems to select out the fat horse, so that of glanders and mange prefers the poor and debilitated one.

It is a point of great practical importance to understand the feeding of horses which have got low in condition. To cram them with nitrogenous food is a grave error. Grain passes away undigested, and only acts as an irritant : the diet should, if possible, be grass, the natural food of the

herbivora. Only gradually should they be brought on to hay and oats, with or without a certain proportion of linseed; and in each case the grain should be prepared to meet the weak digestion of the animal.

Sudden changes from poor to rich food should be most carefully guarded against in all animals, it cannot be assimilated, and does harm.

Notwithstanding the views which have been held in the past regarding the effect on the skeleton of a deficiency of salts in the food, it is probable that with an ordinary diet no deficiency of salts exists. It is not conceivable that any vegetable food as ordinarily supplied to adult animals is deficient in salts, and the cause of bone softening or swelling must be looked for elsewhere. With the growing animal the matter is different, here salts are required in considerable quantity (p. 100), and a deficiency will certainly affect the growth of the body.

#### *Conditions of Digestibility and Assimilation.*

The term digestibility is employed here in the sense in which it is ordinarily used, viz., as indicating whether a food agrees or disagrees with an animal.

Experience shows there are some foods which agree with the system better than others; there are some which disagree if given in too large a quantity, though they are found valuable if given in proper portions. There are foods which disagree because the animal is not used to them, though by being gradually introduced into a diet they produce no derangement. There are foods which though perfectly suited to one class of animal disagree with other classes.

Food is frequently described as rank and innutritious, especially that given to cattle; both digestibility and assimilation are here concerned. Hæmo-albuminuria in cattle has been attributed to this cause, especially when the husk and fruit of the oak and beech form part of the diet. Rank herbage and large quantities of turnips will also produce diarrhœa and dysentery in cattle, while large

quantities of coarse, dry, indigestible food, with a diet containing insufficient roots, causes impaction of the third stomach.

The age of food exercises considerable influence; new hay and new oats are very properly objected to, as they have not undergone the process of maturing which being kept a certain number of months imparts, and which experience shows adds to their digestibility.

Wheat as a food for horses has a bad name, perhaps it is not altogether deserved. Horses are fond of it, and the digestive trouble which has been known to follow its use may have been due to the excessive quantity eaten, for it may be laid down as a golden rule that no grain to which an animal is not accustomed should at first be given in anything but small quantities.

Laminitis following the use of wheat might equally well have followed any other digestive trouble due to the introduction of a new food in excessive quantity, considering the sympathy existing between the alimentary canal and the feet.

Both barley and maize are valuable horse foods, and at one time each was blamed as producing laminitis and intestinal trouble; but the remarks made regarding wheat apply quite as strongly to barley and maize, which we know to be really valuable articles of diet.

Green food will produce diarrhœa or more serious digestive trouble, such as acute tympanites, with animals not used to it; but, again, it is largely a question of quantity, and in a short time with care the stomach and bowels become perfectly tolerant. Rank herbage of any kind, young grass and clover, grass consumed before the dew is off it, or stale 'grains,' are all causes of tympanites in cattle.

In all the above cases, the food has disagreed owing to mismanagement, and one has no difficulty in grasping the fact. But it is not an easy matter to understand how a food suddenly causes trouble to which a horse, for instance, has for years been used, where the quantity received day after

day has perhaps not varied more than a few ounces one way or the other, where the hours of feeding, watering, and work have been carried out with clockwork regularity, in fact, where every condition has been present to ensure success, yet one day it fails, and the animal is seized with colic from no apparent cause.

Such cases are frequently met with amongst large bodies of horses; the most careful enquiry fails to reveal the slightest irregularity in stable management, and these cases can only be regarded as due to some stomach or intestinal cause, which suspended temporarily or completely the digestion of the food, with the result that it acted as an irritant. Whatever it is, the cause belongs to the animal and is not outside it.

But there are conditions operating from without which seriously affect the digestibility of food, and one, if not the chief cause, is work. A hard day's work may produce colic; or work harder than usual, and especially if prolonged beyond the time the animal is generally worked for, is a fruitful cause of colic, through indigestion. During ordinary work both stomach and intestinal digestion go on as usual, but during excessive or severe work, it is a fair assumption that in animals which are not used to it, digestion is affected. It may be secondary to muscular fatigue, or concomitant with it, but digestion certainly appears to be suspended, and the food in the stomach or more particularly intestines sets up irritation.

Why this indigestion is produced is far from clear, it may be from loss of fluid from the intestinal canal the result of sweating and respiration, or it may be a pure suspension of digestive action; but the important fact remains that colic and work are intimately connected, and that is why more cases of colic occur during the late afternoon and night, than occur during the early part of the day.

The sympathy between the stomach and skin shows itself in more than one way; the peculiar condition known as 'hide bound' in poor and unthrifty horses is universally recognised. But there are distinct pathological conditions

affecting the skin the result of digestive trouble; for example, the irritation and often eruption shown by horses too highly fed; the sudden swellings of nettle rash, and in India the acute eczema affecting horses, probably due both to the highly nitrogenous food they receive, but also to grass which they get in a wet condition at certain times of the year.

A food may prove indigestible owing to its method of preparation; the pea and bean class require crushing, some even need boiling or soaking before they can be dealt with. Parched barley is in some parts of the world the only method by which the grain is employed, as it is found in this condition to be better digested, and not pass whole through the animal.

The continual use of 'grains' for dairy stock is said to ruin the system, and that two years of such feeding is sufficient to destroy the health of any cow. Presumably this condition is brought about through the digestive system, probably as the result of the long-continued use of an acid food.

Foods which have been frozen, such as roots and potatoes, are harmful to stock. We do not know the chemical changes which have occurred as the result of frost, but the effect is to render them highly indigestible or even poisonous.

We have later on drawn attention to the influence of certain foods, such as cabbage, on the taste imparted to milk, and the 'ropy' condition which some believe milk suffers from as the result of the use of tares as food. These cannot, it is true, be regarded in the light of disease, but they are conditions imparted by food, and may be conveniently noted here.

#### *Conditions of Quality.*

The quality of a food is affected by its mode of growth, care in saving and preservation, its cleanliness, and the inroads of animal and vegetable parasites.

If the land on which a crop is grown be poor in quality

the produce will be in a similar condition; it will be deficient in those constituents on which its nutritive value depends. Oats, for example, with good manuring will produce sixteen bushels for every bushel of seed sown, whereas on poor land only five bushels are produced.

The character of the soil affects the quality of the crop, oats grown on clay soil are superior to any others, while rye flourishes best on a light sandy soil, and barley on a good loam.

The age at which the crop is gathered exercises a profound influence on the nutritive value, if the hay is cut late much of its properties are lost, if cut too early it has failed to reach the full extent of its value as fodder. Wheat cut about a fortnight before it is ripe contains the most proteid and starch, the bushel weighs heavier, and the straw contains most nourishment; if cut late the ear contains more cellulose, a reduction in flour, and an increased amount of bran.

The season is responsible for the quality of the food, wet years are productive of parasitic diseases and delay in maturing. Hay suffers seriously as the result of wetting, as some of its most valuable properties are washed out of it through being soluble in water.

The age of grain and fodder up to a certain time enhances their value; all grain and fodder are indigestible if they have not matured. There are certain chemical processes occurring in new hay and grain after storing, which remove such irritating properties as they possess, and render the nutritive principles easier of digestion. This seems to apply to all hay and grains, and many other substances, for instance, mangels.

Food badly saved through a wet season or other causes, is a fruitful source of trouble; the material deteriorates, becomes mouldy, important chemical changes occur to the proteids and starches, rendering them unfit for food or even poisonous. The risk which is run by feeding on badly saved material entirely depends upon the extent to which deterioration has taken place; it appears to be less



harmful with hay than with oats. The degree to which it may become affected varies from a faint mouldy smell to a mass of decomposing and offensively smelling material.

Hay and grains are not the only food substances which undergo decomposition and produce disease. Roots and potatoes are frequently given in an unsound state from motives of economy, and produce symptoms either of poisoning or extreme digestive irritation.

Cleanliness is an important condition of quality, stomach and intestinal trouble is very common as the result of dirty feeding; sand, gravel, and stones are found in bad samples of corn. Gravel and sand frequently accumulate in the large colon, the result of feeding on dirty grain, such as the 'cooltee' of Southern India; colic, enteritis, and impaction are in consequence very common. With army horses and mules, sand and gravel in the intestines are frequently met with among those living in the open; it is taken in with the food, and frequently licked up.

A food may cause mechanical irritation without being dirty, the awns of barley and of certain grasses, for example, also undecorticated cotton cake, which is held responsible for diarrhoea in cattle, and abortion in cows, due to the irritation it is capable of producing when given in large quantities.

Intestinal calculi are the result of the accumulation of the phosphates of lime and magnesia derived from the food, particularly bran and oats; the salts of these accumulate in the bowel instead of passing away with the fæces, and form a calculus around any foreign body such as a nail or stone.

Oat hair calculi are formed from the fine but indigestible hairs which are to be found covering the grain inside the external envelope; in the bowel they are frequently mixed with the salts of the food.

Millers' horses had the reputation at one time of being very prone to intestinal calculi, through being fed on sweepings from the mill floor, with which were chips from the grinding stones; the chief cause of their trouble was

due to feeding on large quantities of bran, which is productive of calculi from the amount of insoluble salts it contains.

To all these causes of dirty feeding may be added the presence of nails, wire, needles, and other metallic substances mixed with the corn by accident. To such an extent may these be found, that some large employers of horse labour pass the whole of their corn over an electric plate in order to get rid of them.

There can be no doubt of the great saving effected in large establishments by thoroughly cleansing grain before giving it as food. The small purchaser is not so liable to obtain foreign bodies and dirt, as the larger consumer who buys by the ton at a special contract rate.

#### PARASITES AFFECTING FOOD.

The fungi affecting food may broadly be divided into those which attack the plant during its life (parasites), and those which occur after its death (saprophytes). A further division is into animal and vegetable parasites.

These organisms destroy the fodder or grain on which they live. From an agricultural point of view the parasites or those which affect the plant during its life are more serious than the saprophytes which attack the crop after it is gathered. From a veterinary point of view there is little to choose between them; both may be equally harmful, not necessarily to the animal but to the food, which is either partly or completely destroyed. In many cases not only is the food rendered uneatable but positively harmful.

The principal *Vegetable Parasites* affecting the plant during its life are *Bunt*, *Smut*, *Rust* and *Mildew*, and *Ergot*, while those attacking the plant after its death produce *mouldiness* and belong to the *Mucor*, *Penicillium*, and *Aspergillus* groups.

*Bunt* is a parasitic disease due to *Tilletia caries*; it affects wheat, barley, and maize. It is a disease very difficult to detect in the early stage, and requires carefully looking for.

The grain in course of time gets converted into a black or olive-coloured greasy powder, of a fishy objectionable odour.

*Smut* (Fig. 26) is a disease which attacks the flowering heads of grasses and grains, more particularly, wheat, barley, oats, and rye. It commences as a white deposit, but later turns to a black mass. This consists of spores of the fungus *Ustilago carbo*. The effect of this fungus is to completely destroy the flowering head, so that the whole ear disappears and nothing but its framework is left. The disease is very readily detected, and unlike Bunt it has no odour.

*Rust and Mildew* are produced by different stages of the same parasite, known as *Puccinia graminis* (Fig. 27). It affects all grasses and cereals, and is an extremely serious disease from an agricultural point of view.

The life history of the parasite is complex and interesting, it requires to pass through two different host plants in order to complete the cycle of its existence, and in each host it produces a distinct disease; in fact, its behaviour is more like that of an animal parasite.

The stems and leaves of all grasses and cereals are liable to be attacked in the early summer by yellowish-red lines

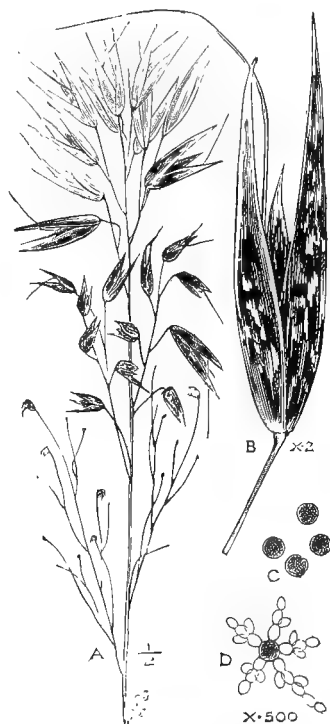

Fig. 26.—Smut of Oats (Fream).\*

A, panicle of oats attacked from below upwards; B, spikelet with the fungus in an early stage of growth; C, free spores of *Ustilago carbo*; D, spores germinating and producing yeast-like buds.

\* 'Elements of Agriculture.'

and spots. The colour is due to the spores of the fungus, which can be shaken off the leaf and are found to be of a rusty appearance. These spores, known as *uredospores*, are produced by the growth of a mycelium in the substance of the leaf, and should they get detached from the plant by air currents or otherwise, and fall on members of the grass tribe, these become infected with rust.

As the summer advances, the mycelium on the leaf which has been producing the orange-red uredospores, now

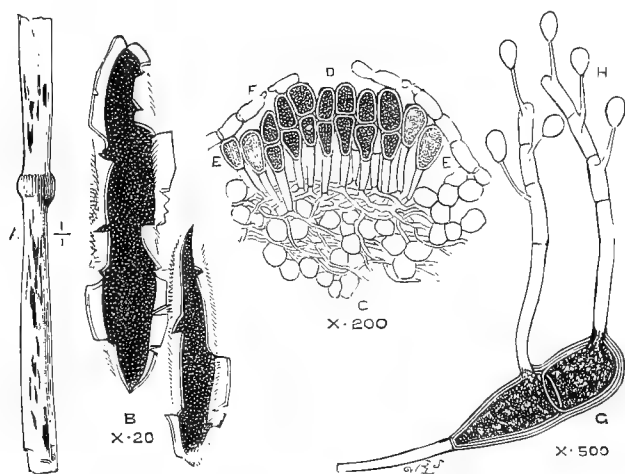

Fig. 27.—Rust and Mildew (Fream). A, part of stem of oat plant attacked by *Puccinia graminis*; B, Two of the blotches from A enlarged 20 diameters; C, *Puccinia graminis* within the stem, but near the surface, bursting the cuticle at D, beneath which are seen the teleutospores; E E, Spores of *Uredo linearis*, which sometimes surround the teleutospores of *P. graminis*; G, Teleutospores germinating and producing sporidia at H. These sporidia on germinating give rise to *Evidium berberidis*.

produces a second kind of spore; the reddish-yellow lines and spots on the leaf give way to marks of a much darker colour. Finally, the further production of orange-red spores ceases, and only the second kind of spore is formed from the mycelium. This is the condition known as *mildew*.

This second spore, known as a *teleutospore*, is incapable (unlike the first kind) of producing disease if placed on a healthy plant, the fungus must pass through another plant

before it possesses any virulent properties to the grass tribe. It germinates, producing a small filamentous outgrowth which in turn bears usually four very small spores of a third kind. These are known as *sporidia* (Fig. 27, H). They are transported by the wind to another plant, usually the barberry, in the leaves of which the sporidia of *Puccinia* cause a filamentous growth, or mycelium, which bears a third kind of spore known as an *aecidiospore*; this placed on wheat or grass infects them with rust.

The effect of the attacks of rust on the stems and leaves is to divert the nourishment in the plant, with the result that the grain becomes shrivelled, thin, and inferior, while the straw may be quite unmarketable owing to its colour.

*Ergot* (Fig. 28) is a fungoid disease produced by *Claviceps purpurea*. It is popularly supposed to attack only rye, but maize, wheat, and grasses are also affected.

Ergot is a horn-shaped, grooved body, known as a sclerotium; it is of a purplish-black colour, often half an inch in length, standing out prominently from the flowering head of the plant. When fully developed it drops out and lies dormant in the ground from summer to spring. The sclerotia then germinate, and put out small stalks each with a rounded head containing sporangia with their spores (Fig. 29). These when carried into the air again infect the grass family, and so complete the cycle of their existence.



Fig. 28.—Spike of Ergotized Rye (Smith).\*

\* 'Diseases of Field and Garden Crops': W. G. Smith.

*Mouldiness* is caused by indifferent saving or storing. Grain and hay exposed to rain or damp, are liable to undergo this change; they become covered with moulds belonging to the *Botrytis*, *Penicillium*, *Aspergillus*, *Mucor* and *Oidium* groups (Figs. 30, 31, 32).

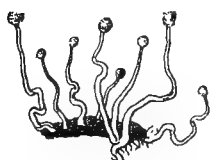

Fig. 29. — Ergots germinating (Smith).

These fungi flourish on the nourishment in the food, while the latter undergoes important chemical change, varying in degree from a mere trace of mouldiness, to a decomposing dark mass of objectionable odour.

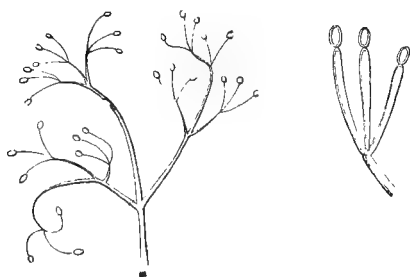

Fig. 30. — *Botrytis grisea* (Boucher).

In consequence of wet and damp the grain darkens in colour and sprouts; its starch is changed into sugar, and its chemical characters for food purposes are hopelessly altered. Fermentation also occurs, and as a result the temperature of the whole mass is raised, and it becomes quite hot to the hand.

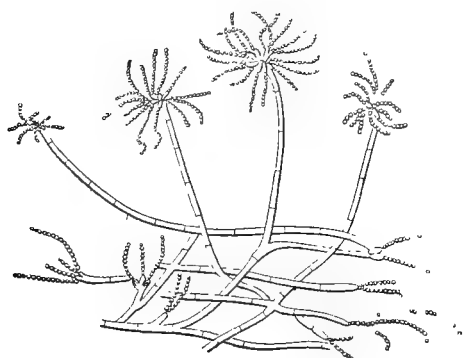

Fig. 31. — *Penicillium glaucum* (Boucher).

It is not necessary for the process to be carried as far as described, the grain may be dealt with before it reaches this stage, and spread out to dry, or even dried artificially in kilns, but it is still damaged, and both useless and dangerous for food purposes. The drying gets rid of the moisture, stops the fungoid growth, and prevents sprouting,

but it cannot repair the damage done to the grain. This is dark externally, and on splitting it the flour is found discoloured, the grain also has a peculiar smell known as 'foxy.'

With fodder the air drying will kill the fungi, and the spores, which are often very irritating to the nostrils, may be got rid of by shaking; but the hay has lost its true aroma, and nothing seems to get rid of the faint mouldy smell, even after prolonged exposure to air and sun. As the result of fermentation the mass generally darkens in colour, but this should not be confounded with the darkening which results from fermentation in the stack, where hay has been ricked too early.

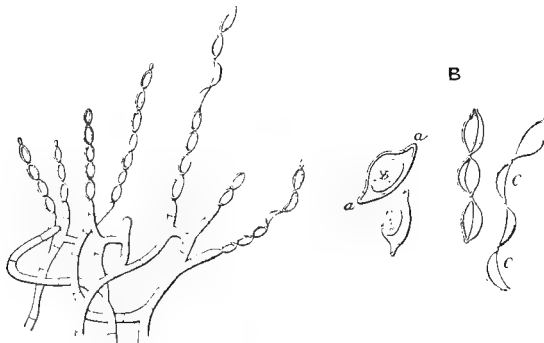

Fig. 32.—*Oidium aureum*. B, Spores further magnified (Boucher).

As the result of mouldiness hay has lost much of its nourishment, it is brittle, and though perhaps not so dangerous as damaged grain, it is nevertheless innutritious.

*Clover sickness* is due to a fungus, *Sclerotinia ciborioides*, which attacks the roots and stems of clover, the red clover especially.\* Once it finds its way into a field, no more clover should be grown on it for some years. This disease is only of interest to the agriculturalist.

The *Animal Parasites* affecting food are divided into those attacking it during the life of the plant, and those which

\* *Journal Royal Agricultural Society of England*, vol. lxiv., 1903: H. Güssow.

live on it after it has been saved ; the latter are by far the larger class.

*Ear cockle*, *Purples* or *Peppercorn*, is a disease of the ear of wheat, oats, and rye, due to a nematode worm, *Vibrio tritici* (Fig. 33), which enters the grain and converts it into a gall. Externally the gall is dark in colour, while its interior is filled with a cottony mass consisting of coiled up parasites.

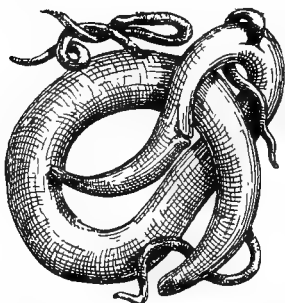

Fig. 33.—Ear Cockle, showing the nematoid worms (Smith).

The animal parasites attacking food after the life of the plant, were especially studied by Mégnin, to whose researches, noticed in Magne's work, we are greatly indebted.

Two kinds of parasite attack forage and grain, viz., insects and arachnidans. To the former belong *Tenebrio mollitor* (Fig. 34) which infects forage, and *T. farina* which attacks grain. The latter is more serious than the former, for the larvæ of the *Tenebrio* of grain live in the flour, whereas those of hay do not live in forage. In both cases



Fig. 34.—*Tenebrio mollitor*, slightly magnified (Magne and Baillet).

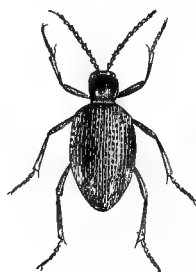

Fig. 35.—*Ptinus fur*, magnified (Magne and Baillet).

they are very destructive and reduce the food to powder. They are actively assisted by *Bos-trichus longus*, *B. sperocephalus*, and *Ptinus fur* (Fig. 35); the larvæ of all these develop in the food, and are consequently most destructive.

The Acari which live on grain and forage belong to the genera *Oribata*, *Gamasus*, *Tyroglyphus*, *Cheyletus*, *Trombidium*, and *Argas*. All these are most destructive, while the *Gamasus* (Fig. 36) and two species of *Argas* (Figs. 37, 38) cause such irritation to the



skin of the horse, that they have been believed by some to be capable of producing mange. This, however, is not correct.

The Acari reduce the food to powder, and what they do not eat is soiled by their débris. They can easily be seen by placing some of the material on black paper. Fortunately they are themselves exposed to the attacks of an enemy *Psocus pulsatorius* and *veloce*, both of which actively pursue and destroy them, and at the same time do no damage to the food.

The weevil, *Calandra gramina*, is a very common pest of grain; it is most destructive, reducing it to an empty shell. Weevils are generally found in grain which has been kept for some little time.

The effect on animals partaking of food affected with vege-

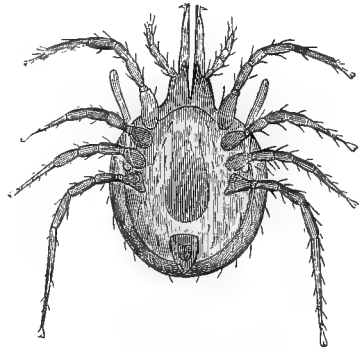

Fig. 36.—*Gamasus fenorum*, magnified (Magne and Baillet).

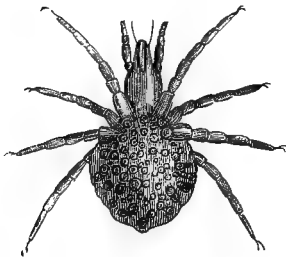

Fig. 37.—Small yellow argas, magnified (Magne and Baillet).

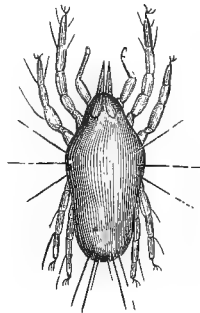

Fig. 38.—Small white argas, magnified (Magne and Baillet).

table parasites is by no means regular; they may produce intestinal disturbance, kidney trouble, and even death, but whether it is due to the fungus, or to chemical changes in the grain does not appear clear; Boucher attributes it to

the fungus, and figures *Oïdium aureum* (Fig. 32) as having killed a horse. Varnell\* killed horses in thirty-six hours with mouldy oats, paralysis both of the tongue and hind-quarters being the most prominent feature. Enteritis was also found to be present on post-mortem examination.

Ordinary mouldiness of forage has produced the same symptoms, and Gamgee describes an epizootic disease in Scotland due to mouldy grass, which produced acute stomach and intestinal trouble, cerebral derangement, and paralysis. Acute stomach tympany has been observed in the horse as the result of mouldy grass.† In all these cases the amount of poison swallowed was probably considerable. In small doses, as in partly damaged corn, the chief symptoms appear to be referred to the excretion of urine, which is greatly increased in amount.

Loss of condition will naturally always accompany long continued feeding on damaged food, owing to its defective state.

Bunt and Rust do not appear to produce any special form of disease, though it is said the spores of rust have occasioned serious disease in lambs.‡

Ergot is popularly believed to produce a special group of symptoms, accompanied in pregnant animals by abortion, and in others by sloughing of parts of the body. It is stated§ that ergotized food produced a curious disease in Germany in 1841, affecting the white portions of horses' skins which became gangrenous, while the dark portions remained unaffected. Varnell and others have recorded the same fact, so it must be accepted as correct.

On the other hand, all experiments made with ergot appear very disappointing; sheep and cows have been fed daily for months on large quantities of the fungus without producing any effect. Perhaps horses are more susceptible

\* *Veterinary Record*, vol. vi., No. 24.

† *Quarterly Journal of Veterinary Science in India*, vol. ii., No. 5.

‡ *N. B. Agriculturist*, 2nd September, 1880.

§ *Veterinary Record*, vol. xi., No. 24.

to ergot than ruminants ; it is quite certain there are some poisons which affect ruminants and not horses, and *vice versa*.

#### HARMFUL AND POISONOUS FOOD SUBSTANCES.\*

It cannot be pretended that a complete list of harmful and poisonous food substances, or plants accidentally gathered with the food, is here presented. It is a very special and complex subject, requiring the united efforts of the chemist, botanist, and veterinary surgeon, in order to fully elucidate the principal points, and one may say the whole subject is at present in its infancy.

In the case of well-known poisonous plants such as aconite, belladonna, hemlock, etc., it is not suggested these are used as food, but that they may be accidentally mixed with forage by growing on the land from which it has been cut, or what is more commonly the case, actually gathered by the animal in the process of grazing.

This brings up a point which is universally recognised, that animals when grazing are most liable to poisoning at those seasons of the year when herbage is scarce, or at the spring of the year when plant life is coming once more into activity. This holds true for every country. Likewise the rule that animals constantly pastured on dangerous ground learn from experience what to avoid, while new comers fall victims.

Perhaps the best known poisonous plant in Great Britain is the Meadow Saffron, *Colchicum autumnale* (Fig. 39). It is found wild in many parts of England, and may be recognised by its subterranean bulb-like stem, more properly termed a *corm*, from which rises late in the year a light purple, somewhat spotted flower on an almost leafless stalk. The leaves do not appear till the next spring ; they are elongated, sword-shaped, with somewhat sheathing petioles. The whole plant is poisonous, whether fresh or in the dried condition.

*Colchicum* is sometimes called the Autumn Crocus. It

\* My best thanks are due to Dr. J. R. Green, F.R.S., for notes and suggestions in the preparation of this section.

differs from the true crocus in having six stamens and a superior ovary—that is, an ovary hidden by the bases of the floral leaves which arise below it. Colchicum causes



Fig. 39.—The Meadow Saffron (*Colchicum autumnale*).

gastro-enteritis, diarrhœa, and hæmaturia, and appears to be poisonous to all animals.

The Natural Order *Umbellifereæ* includes many poisonous plants.

They have many characters in common, the order being characterized by its large, much-divided leaves, often sheathing at their bases, and their large compound umbels of small white or yellow flowers.

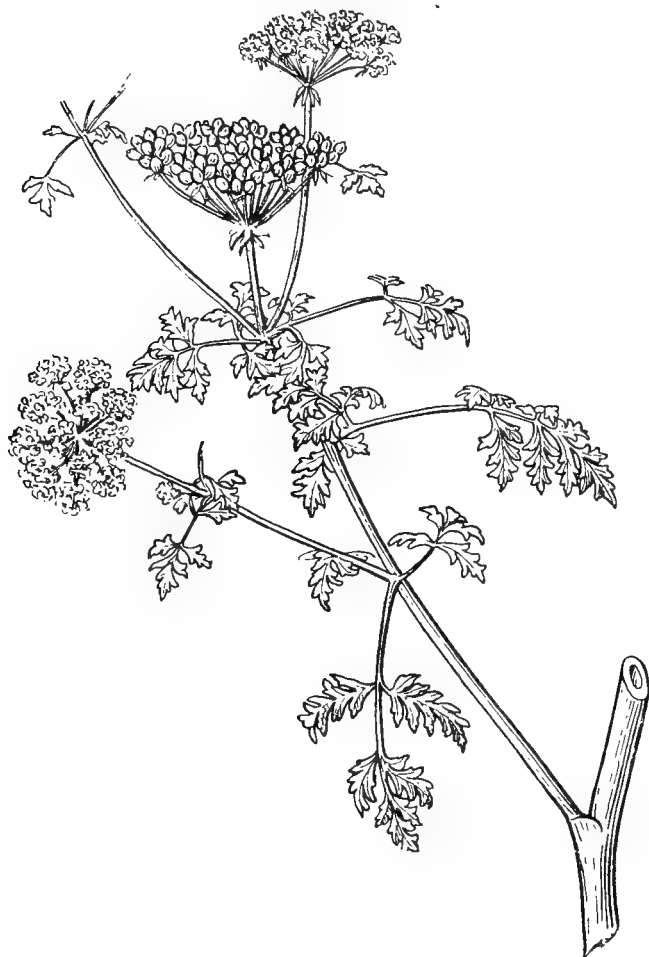

Fig. 40.—Hemlock (*Conium maculatum*).

Prominent among the poisonous members of the order is the Hemlock, *Conium maculatum* (Fig. 40). The stem of this plant is green, but freely sprinkled over with large

purple blotches. When bruised, the leaves and other soft parts of the plant emit a disagreeable odour resembling that of mice. The fruit of the plant is characteristic; it is somewhat globular, tapering upwards to a blunt apex,

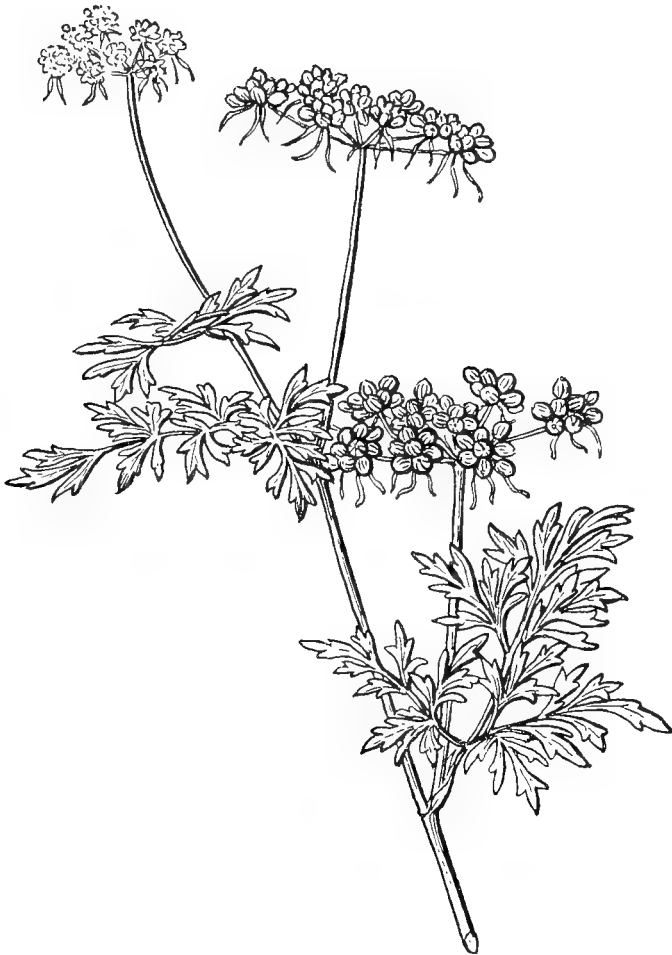

Fig. 41.—Fool's Parsley (*Ethusa cynapium*).

and marked on each side by five corky ridges running from base to apex. The fruit contains no oil glands.

The active principle of the plant exists in largest quantity

in the fruits. It is an irritant and subsequently narcotic poison, its effects culminating in muscular paralysis with convulsions.



Fig. 42.—The Cowbane (*Cicuta virosa*).

The Hemlock is sometimes confused with the Fool's Parsley, *Aethusa cynapium* (Fig. 41), which is not nearly so poisonous, though there are instances recorded of its

possessing deleterious properties. It can be distinguished by the bluish-green colour of the leaves, and by the fact that each of the small simple umbels which unite to form the compound inflorescence has three narrow pointed bracts projecting vertically downwards from it. These give the inflorescence a very distinctive appearance.

The deleterious properties of this plant are denied by some, and it is said Linnæus gave it to cows, sheep, and horses, without apparent injury.

The American Water Hemlock, *Cicuta maculata*, is extremely poisonous, and is responsible for the bulk of sheep and cattle poisoning in the United States.\* Both the leaves and rhizomes are virulent; the latter smell of parsnips with a slight addition of musk. A piece of the Oregon Hemlock the size of a Walnut will kill a cow. The poison is a toxine and not an alkaloid.

The English species of this genus, *Cicuta virosa*, the Cowbane (Fig. 42), is found growing in moist places, generally by the edges of ponds or ditches. It has a large fleshy rhizome containing a yellow opalescent juice, and peculiar in being hollowed out into several chambers in its interior. The stem is furrowed and bears flowers and fruit of the typical Umbelliferous character, the fruit being marked by the teeth of the calyx projecting above it. The poisonous properties resemble those of Hemlock.

The genus *Cenanthe* has several poisonous species. The most prominent of these are *C. crocata* and *C. phellandrium*, both often called Water Dropwort. The former (Fig. 43) is the more virulent, the poisonous properties residing chiefly in its fleshy tuberous rhizomes which somewhat resemble parsnips. The plant is often about four feet high, and its leaves, though much divided like those of Hemlock, are larger and the segments coarser. The acid sap of the succulent part turns yellow on exposure to air. *C. phellandrium* frequently grows in water, and its rhizomes are then long and slender. The segments of the leaves are

\* 'Poisonous Plants,' by V. K. Chesnut, Year Book, Department of Agriculture, U.S.A., 1900.





Fig. 43.—The Water Dropwort (*Eranthe crocata*).

smaller than those of the other species ; they are sometimes submerged and then become long and thread-like.

Another species, *Æ. fistulosa*, has hollow stems and hollow leaf-stalks, bearing only a few segments at their summits.



Fig. 44.—The Deadly Nightshade (*Atropa Belladonna*).

Chesnut, in the article already referred to, draws attention to other poisons resembling that of Hemlock, found in the Heath family, *Ericaceæ*, very poisonous members of

which are 'sheep laurel,' *Kalmia angustifolia*, and 'Calf Kill,' *Leucothæa Catesbæi*.

Several poisonous plants are met with in the same natural order as the potato (*Solanaceæ*). The best known



Fig. 45.—The Bitter-sweet (*Solanum Dulcamara*).

of them is the plant which yields belladonna, *Atropa Belladonna* (Fig. 44). It grows generally on chalky soils, and on the waste ground near ruins. It is a perennial herb, dying down every autumn. The leaves are ovule

and glossy with a peculiar heavy odour. The flowers are bell-shaped and purple in colour; the fruit is a berry of brilliant black colour, about as large as a cherry.

Another member of the order, the Bitter-sweet, *Solanum*

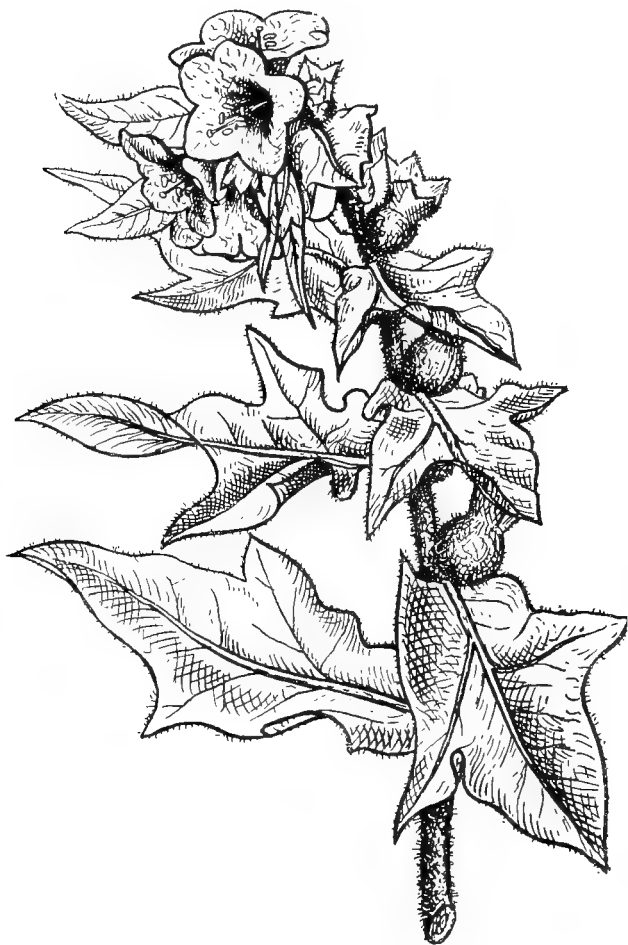

Fig. 46.—The Henbane (*Hyoscyamus niger*).

*Dulcamara* (Fig. 45), grows in hedges, scrambling among the twigs. The plant has a long slender stem, bearing leaves with ear-like appendages and long cymes of purple flowers. The yellow anthers project in cone-like fashion

from the centre of the corolla. The fruits are clusters of bright scarlet berries. Another species, *S. nigrum*, is found upon waste ground; its fruits are black.

The Henbane, *Hyoscyamus niger* (Fig. 46), is another member of the same group. It is often found on waste ground or rubbish heaps, and is occasionally met with by the sea-shore. It is a densely leafy plant with a very sticky surface, due to exudation of resinous matter from the hairs which cover it; it has a peculiar aromatic odour. The stem grows to a height of about one to two feet. The flowers are borne all on one side of the floral axis and are yellowish-gray, marked by a network of purple streaks. The fruit is dry, and is enclosed in a persistent calyx which grows somewhat after the corolla falls.

Other members of the family are Stramonium (*Datura stramonium*) and Tobacco (*Nicotiana tabacum*). Even potatoes have been suspected at times of producing poisoning; but the alkaloid is mainly contained in the leaves and flowering heads, which are poisonous and should never be used for stock.

The Natural Order *Ranunculaceæ* includes several plants which are poisonous. Among them the most conspicuous is the Aconite, *Aconitum napellus* (Fig. 47). It grows to a height of about three feet, the stem springing from an underground rhizome or root-stock which is fleshy and much resembles the root of the horse-radish. The leaves are much divided, and the flowers, which grow in long upright racemes, are pale-blue in colour. They are very irregular in construction, the calyx being the showy part, while the corolla is represented by two long-stalked glandular structures hidden below the largest of the sepals.

The Hellebore, *Helleborus niger*, is another poisonous member of the family. Four species of *Ranunculus*, *R. sceleratus*, *R. acris*, *R. flammula*, and *R. lingua*, are described as irritating to the digestive canal, producing tympany, colic, inflammation, and, in certain cases, death. The Upright Buttercup, *Ranunculus acris*, if in abundance in a

pasture, may cause horses and sheep to scour. It is very acrid, and produces inflammation and ulceration if applied to the skin. These plants are much more irritating in their



Fig. 47.—The Aconite (*Aconitum napellus*).

green state; drying robs them, and many other irritating and poisonous plants, of their deleterious properties, so that when mixed with hay they are often harmless.

*Actæa spicata* is generally avoided by animals, but when partaken of is poisonous. In small quantities it diminishes the secretion of milk.

The *Anemone* group contains many poisonous plants, which produce dysentery and hæmaturia if taken in any quantity. *Clematis flammula* and *vitalba* both produce vesication of the skin in the green state, but lose this property on drying.

*Gratiola officinalis* is very poisonous both in the green and dry state, producing enteritis and purging. *Coriaria myrtifolia* and *Fritillaria meleagris* and *imperialis*, are all irritant poisons. *Rhus coriaria* produces great skin irritation, and *Allium*, Crow garlic, contains an irritating powerfully smelling essential oil, which in large doses causes death. The smell of this oil may readily be distinguished in the excretions, and also in the milk.

The genus *Euphorbia* furnishes many members possessing markedly poisonous properties; dogs' mercury, for instance, causes inflammation of the bowels and diarrhœa in both sheep and cattle; horses are also affected, but it is said they generally avoid it.

Chesnut\* describes the *Larkspur* as poisonous, and says this view is held by the majority of stockmen of the north-west of the United States. There are six hurtful species, they produce symptoms resembling aconite poisoning. The antidote is atropine hypodermically, and potassium permanganate by the mouth.

The same author refers to the poisoning produced by the Death Camas, *Zygadenus venenosus*; this is a poisonous bulb which looks like grass when young, and resembles the poisonous Tulp of South Africa, though the plants are different botanically. The Camas affects all animals but more particularly sheep.

*Corn Stalk disease*, Chesnut tells us, is not understood; cattle get affected by grazing on maize crops after they have been reaped, but whether it is an insect or a fungus which is to blame has not been determined. *Green Sugar-sorghum* may

\* *Op. cit.*

also cause poisoning, but the cause is unknown. It appears to be limited to the second growth. Davy\* refers to it and tells us *Sorghum vulgare* (Kaffir Corn) is capable of doing the same thing. A poisonous enzyme is probably the cause. Chesnut suggests it may be in the blossom that the poison resides, as in the Guinea Corn of Barbadoes.

Boucher† describes both the grain and straw of buckwheat as dangerous, he says it produces symptoms resembling Darnel poisoning, and causes swelling of the head. In England buckwheat has been blamed for affecting the eyes. The same author draws attention to the effect produced on milk by the leaves of the Boxwood and Spruce laurel, which he says are not poisonous but impart an abominable taste to the milk. The leaves of the Walnut and Buckthorn he states arrest the secretion of milk, while those of the Beech, Ash, Hazel, and other trees, produce constipation and hæmoglobinuria.

The fruit of the oak and beech trees are blamed for producing hæmo-albuminuria and impaction of the third stomach in cattle, while the young shoots of resinous trees, as well as the acrid ranunculus and colchicum, are believed to produce 'Moor-ill.'

Boucher describes the peculiar disease resulting from feeding cattle on the pulp of Beetroot after sugar extraction. He speaks of it as the *Pulp Disease*, and describes it as due to a fungus growing on the fermentable mass; it causes intestinal irritation, diarrhoea, and death. He also mentions the eczema, known as *Pulp Eczema*, due to feeding cattle on potato pulp, after the extraction of the starch. He describes skin eruption, tympany, abortion, and paralysis as following the excessive use of Distillers' grains.

South Africa has a bad reputation for poisonous plants, but beyond 'Tulp' very little is known of them. Davy

\* 'Cattle Poisons of the Transvaal,' J. B. Davy, F.L.S., *Transvaal Agricultural Journal*, No. 5, vol. ii.

† *Hygiène des Animaux Domestique*.



has recently\* drawn attention to several which are harmful, but there is yet much more to learn about them. Farmers and natives of equal experience are not fully agreed as to which are the poisonous varieties, and this is due mainly to the fact that there are often several species of the same plant, some of which may be harmless while others are noxious; for instance, there are no less than forty-five species of 'Tulp,' and the number of these which is poisonous is unknown.

*Meliga Dendroides*, the 'Dronk-gras' of the Dutch, possesses well marked poisonous properties, causing giddiness and intoxication, the symptoms resembling Darnel poisoning. Davy states it is probably a species of *Equisetum* or Horse tail, a well-known poisonous grass in America and the Continent of Europe. Magne refers to the genus as being very poisonous and producing hæmaturia. Boucher says the *Equisetum palustre* (Fig. 48) is poisonous under certain unknown conditions, and that it produces symptoms resembling alcoholic intoxication. It is this property which has caused the Boers to give it the name of 'Dronk-gras,' and it is conceivable the European and South African plants are very closely allied.

Darnel, *Lolium temulentum* (Fig. 49), known in Europe and America for its poisonous properties, has now been introduced into South Africa with seed-grain. In appearance it is very like Rye grass, but the glumes or scales which enclose each spikelet of flowers are as long as or longer than the whole spikelet; for years the seeds have been known to be poisonous, but the risk run must be small, for Magne quotes experiments by Grogner,

\* *Op. cit.* I am greatly indebted to Mr. J. B. Davy, Government Botanist to the Transvaal, for information on this and allied subjects.



Fig. 48.—*Equisetum palustre*.

who found that *Lolium* was only poisonous to horses in considerable doses, two to six pounds, more than is ever likely to be obtained by ordinary grazing or in hay. The poison is known as *Temuline* and is said not to affect oxen, but poisons other animals, including man. It produces vertigo, and symptoms of loss of co-ordination.



Fig. 49.—Darnel (*Lolium temulentum*).

These are not the only poisonous grasses. *Bromus catharticus* is a purgative, *Festuca quadrivalvis*, a grass growing in Peru, and the *Molinia cœrulea*, a common upland grass in Europe, are both poisonous to cattle. In Mongolia a species of *Stipa* intoxicates horses, while in New Mexico

*Stipa viridula* var. *robusta*, locally known as 'Sleepy Grass,' throws animals into a profound stupor for twenty-four hours or more; they recover from this, and will never again partake of the grass.\*

The Oleander, *Nerium oleander*, a shrub very common in South Africa is excessively poisonous; both the leaves and wood contain an active principle which is allied to Digitaline. A single tuft of the leaves will kill a horse. The oleander of India is equally poisonous, and frequently used for criminal purposes.

The Rhododendron and Laurel are both poisonous to animals; the former produces drowsiness, stupor and death. The Laurel, especially the variety known as the Cherry Laurel, contains an oil rich in prussic acid. The principal symptom is convulsions; the antidote is atropine if the case can be seen in time.

Tulp, *Homeria pallida* (Fig. 50), though commonly spoken of as a grass, belongs to the *Iris* family. When first growing it looks exactly like grass, and as it appears early in the spring before the ordinary grass has time to grow, it is frequently partaken of by horses and cattle.

It prefers low lying ground where it gets the needful moisture, and grows one and a half to two feet high. The common variety has a yellow flower, other species, of which forty-five are known, have blue or lilac flowers.

Both leaves and flowers are poisonous, the symptoms rapidly appear, great abdominal pain, excessive tympany, and death soon occurs. In cattle the eyeballs are retracted, which is regarded by South African farmers as indicative of the trouble.

The treatment which has given the best results is rapid purging by means of Eserine.† The Zulus administer the corm of the plant after burning it; this probably acts by

\* Professor MacOwan, *Agricultural Journal Cape of Good Hope*, 1892.

† A. S. Head, Lieut., A.V.D., 'The Wear and Tear of Horses during the South African War,' *Jnl. Comp. Pathology*, vol. xvi., Part iv.

means of the alkali it contains, as soda carbonate has been given with good results.

*Dichapetalum cymosum* (Fig. 51), known to the Dutch as



Fig. 50.—Yellow Tulp (Davy). 1. Flowering Stem; 2. Corm; 3. Raceme; 4. Flower laid open; 5. Style and anther, showing style-tips.

Gift-Blaar (which only means poison leaf), is a plant common in certain parts of the Transvaal, and exceedingly poisonous to cattle, but not to horses as far as our observations go.

Davy, who has carefully described and figured it, gives clear directions for preventing confusion with two other plants very like it in appearance which are non-poisonous. The true Gift-Blaar has a leaf green on both sides, and placed alternately on the stem; the flower is white and fragrant. The sand apple, *Parinarium*, with which it has been confused has a leaf green on one side, and yellowish-white underneath, this part being covered with a dense wool. The *Fadogia*, the second plant with which it has been con-



Fig. 51.—*Dichapetalum cymosum* (Davy), two-thirds natural size.

1. Underground stem ; 2. Surface of soil ; 3. Flower.

fused, has the leaves placed opposite in two's and three's at each joint on the stem, the flower is green, and scentless.

The symptoms presented by animals are those of strychnine poisoning, and as a rule they die before they can receive attention. Mustard and coffee have been recommended as remedies, but very little is known of the subject.

Klimop, *Cynoctomum Capense*, is another poisonous South African plant which also produces symptoms closely resembling tetanus, finally followed by paralysis. The disease has been fully described,\* and one is struck by the extraordinary clonic muscular spasms and convulsions. The muscular contractions are so great that in the early stage the animal may be unable to get the heel to the ground, and may have to progress on the fetlock; finally it is unable to walk or rise, and general convulsions begin. The convulsive stage may last seven days, and the paralytic stage even longer. Dr. Hutcheon has seen the symptoms set in in half an hour after ingesting the poison.

'Loco' disease, seen in California, is caused by the 'loco' or 'rattle weed,' *Astragalus lentiginosus*.

This is a leguminous plant similar to Lucern in appearance; it produces bladdery pods in which the seeds rattle when ripe. No animal eats it willingly until compelled by drought. Both cattle and horses are affected by it, but it takes more to poison cattle.

The symptoms are mainly nervous, in the first stage hallucinations, if the horse is taken up to a very low rail he jumps it as if it were four feet high. Later he is seized with mania, rears, runs into anything, the eyeballs are turned up so that only the sclerotic shows. The least excitement brings on these convulsive fits, and especially water, so that the animal may fall and drown in a depth of two feet. Finally it dies worn out by constant nervous excitement, and often showing towards the end violent pain. Death may occur in three days or three weeks, or in rare cases recovery may take place. A somewhat similar disease is found in Colorado and New Mexico.†

A leguminous plant in South Africa, *Lessertia annularis*, is poisonous to sheep and goats: the animal is unable to co-ordinate the movements of its limbs, the head wags helplessly backwards and forwards, and in severe cases the

\* D. Hutcheon, F.R.C.V.S., *Agric. Journal Cape of Good Hope*, vol. xxiv., No. 4.

† U.S. Agricultural Report, 1886.

animal soon dies.\* Much the same symptoms are produced by the Australian poison pea, *Gastrolobium bilobum*.

*Slang-Kop*, or snake-head, is a South African poisonous plant, the root being either a bulb or a corm. Nothing definite is known of the Transvaal plant, that in the Cape is *Ornithoglossum glaucum*. It is called Slang-Kop by the Dutch from the fancied resemblance of the flowers to the head of a snake. It is said to be particularly dangerous to sheep and goats.

The Yew tree, *Taxus baccata* (Fig. 52), has been known from very early times to be poisonous to animals, yet in spite of this and its relative frequency there are many questions connected with it which are not universally decided. It has, for instance, been doubted whether both the male and female trees are poisonous, and whether the bark as well as the leaf, or the dried leaf as well as the green one, are toxic.

All these points have been answered in the affirmative in an important communication† made a few years ago; at the same time it was pointed out that there is evidence to show that of the three species of yew all are not equally poisonous; also that the young leaf is not as poisonous as the old one, while the fleshy substance of the berry, it is universally agreed, is non-poisonous, and the seeds of the berry only slightly so.

The poisonous principle has been named *taxine*; very little is known about it, and it has never been obtained in a pure state. *Taxine* is insoluble in water and alcohol, but soluble in ether; the different species of yew contain a variable amount of the poison, which may account for the fact that feeding experiments have been known to fail in producing poisonous symptoms, even when large quantities have been given.

\* Professor MacOwan, *Agricultural Journal Cape of Good Hope*, 1887.

† 'Yew Poisoning': *Journal of the Royal Agricultural Society*, 3rd Series, vol. ii., Part iv., 1892, from which the facts here recorded have been obtained.

Professor Cornevin, of the Lyons Veterinary School, experimentally determined the amount of yew leaves required to kill an animal, which was as follows:—

Horse, ass, and mule,	25 to 31 grains per kilo (2·2 lbs.) of body weight
Oxen, sheep and goats	156 to 186    "    "    "    "    "
Pig ... ..	46    "    "    "    "    "

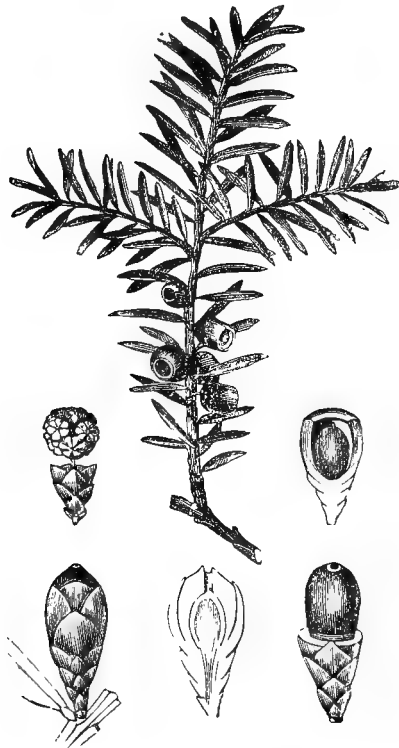

Fig. 52.—Yew Tree (*Taxus baccata*).

Death follows so quickly, that, excepting as the result of experiment, the symptoms are rarely observed. Muscular tremors, especially of the croup, and frequent emission of urine have been observed. In the horse a period of excitement, followed by coma, is frequently absent, though generally present in other animals. Pigs vomit, and cattle



become tympanitic, but there are no symptoms characteristic of the poison.

On post-mortem examination twigs and leaves of the yew are found in the stomach, and it is said that a swollen and yellow condition of the liver are indicative in cattle of yew poisoning.

A shrub in India, the Arbor vitæ, *Biota orientalis*, is also very deadly ; it is sometimes given to horses with their food to improve 'condition.' The berries of the Bead Tree, *Melia azedarach*, known in the Transvaal as the Tame Syringa, have been identified by Davy as the cause of cattle poisoning.

The Beech nut, *Fagus sylvatica*, is used on the Continent of Europe as a cake for feeding cattle, to which it can be given largely with good results, but so poisonous is it to horses, that Wolff says a pound or two of the cake suffices to kill any horse eating it.

The grass known in India as *Spear-grass*, to the Boers as *Stik-gras*, and in America as *Porcupine* or *Needle-grass*, is blamed for causing disease of the rumen owing to the sharp awns. These are said to even pass through the wall of the stomach in sheep, but we are not aware of any literature on the subject.

There can be no doubt that spear-grass irritates the mouth of horses, the sharp barbs penetrate the mucous membrane, and there appears to be no reason why this should not also occur in the rumen.

A very poisonous leguminous grain imported from India, has within comparatively recent years been brought prominently to the notice of veterinary surgeons and horse owners in England, owing to its highly poisonous properties. *Lathyrus sativus*, commonly known as *mutter*s, contains a poison which produces spasm of the glottis in working horses. The poison is evidently a cumulative one, as it requires a few weeks of *Lathyrus* feeding to produce the symptoms.

In the stable the animals look in perfect health, but when put to work the most remarkable dyspnoea occurs

frequently followed by asphyxia. A lathyrus - affected animal is generally worse on a cold wet day. It takes some weeks before the poison is eliminated, during which time the animals must not be put to work.

The lathyrus seed is small and mottled, and its characteristic shape is that of a short, blunt wedge. It bears a dark band along the margin of the wedge.

*Lupine*, another leguminous plant, is largely grown on the Continent of Europe owing to its very nutritious nature, but only sheep can partake of it. It is poisonous to horses and cattle, and even sheep suffer at times if the quantity given be too large. It has always to be mixed with some other fodder.

The poison is known as *lupinotoxin*, and appears to be produced as the result of some peculiar fermentation, either during the life of the plant, or after it has been saved. Steaming the hay for some hours under pressure renders it wholesome, presumably by killing the ferment.

Boucher says that lupines produce inflammation of the digestive tract, and gradual cachexia.

The blackish wrinkled seeds of corn-cockle, *Githago segetum*, sometimes found mixed with oats, are said to possess injurious properties, though we have no personal experience of their ill effects on horses.

*Potato Poisoning*.—For some time it has been recognised that roots and potatoes which have undergone change, either as the result of frost or from ordinary decomposition, are very liable to give rise to symptoms of poisoning.

At present we are ignorant of the toxic substance produced, or whether there is more than one formed under different conditions; it is certain damaged roots and potatoes may at times be given without producing harm, while at others they are productive of mischief.

One thing is clear, that potato poisoning from alkaloid substances, probably generated by bacteria or fungi, is well known to exist, for the poison is in no way removed by steaming the potatoes, which is evidence that the substance in all probability is not of the nature of an organism.

Such cases have been recorded by McFadyean\* and O. Williams,† and experiments made by the former showed that poisonous symptoms occurred about 10 days after giving decayed potatoes. Loss of muscular power and inability to rise were the prominent and persistent symptoms.

*Mineral poisoning* through food is not common, but is represented by Brine poisoning in the pig and Lead poisoning in cattle.

*Brine poisoning* is due to this material being used from the pickling tubs in the preparation of pig's food. The brine mainly consists of common salt and nitre; it produces in excess diarrhoea, vomiting, abdominal pain, blotches on the skin resembling bruises, while the tongue becomes of a brilliant red colour.

*Lead poisoning* is due either to metallic lead being ingested during grazing, as in the vicinity of rifle butts, or from the depraved appetite of cattle, cows particularly, having access to paint and eating the white lead. This can hardly be regarded as food poisoning, but is mentioned here in dealing with the cause of lead poisoning in cattle.

#### *Infection of Food by Specific Germs.*

It has been clearly understood for some years that certain epizootic diseases may be and commonly are spread by the contamination of pastures or food with the virus from diseased animals. Glanders, cattle-plague, and swine fever are good examples of diseases which may easily be spread in this way. But it is only recently that evidence has been accumulating to show that specific diseases may be imported into a country with the food supply, the best example of which perhaps is anthrax.

McFadyean‡ has shown that linseed cake may be contaminated with the virus of anthrax. The contamination occurring on board a ship while the seed is lying in bulk,

\* *Journal Royal Agricultural Society*, vol. viii., part 1, 1897.

† *Veterinary Record*, vol. xvi., No. 807.

‡ *Journal of Comparative Pathology*, vol. xiv., part ii.

or the grain may be obtained from countries well known to be anthracoid, such as Russia or Turkey.

Ship contamination is due to the vessel being infected by a previous cargo of hides taken from animals which have suffered from anthrax. It is well known how resistant the spores of this bacillus are, and how frequently infected hides and skins are imported. Evidence bearing on this point is 'wool-sorters' disease, which is simply anthrax in the human, due to infection by contaminated imported wool.

Ships used for the conveyance of hides and wool, and subsequently for the conveyance of grain, must be regarded as a serious source of danger. In this way it is easy to understand the infection of linseed, the virus in which would not be destroyed by the process of manufacture into cake, and it may also explain the death of horses from anthrax through oats being carried on anthrax-infected vessels. This subject will be dealt with later, it is alluded to here owing to its intimate connection with food.

#### DISEASES DUE TO IMPERFECT PREPARATION OF FOOD.

Experience shows that certain foods require preparation before being given to animals, not only owing to their physical condition, but in the case of working animals to economise time in feeding. This latter aspect of the question will be considered when dealing with the preparation of food; we will here notice those conditions where the neglect of this leads to disease.

'Roots' invariably require to be prepared for cattle and sometimes for sheep feeding, either by pulping or slicing. Neglect of this precaution means a great strain on the teeth of young or old animals, and furthermore is the most common cause of impaction of the œsophagus.

The crushing of maize, peas, and beans is absolutely essential to their mastication and digestion; without some form of preparation, of which crushing is the most common, these grains, from their hardness, very largely defy the

teeth, and in the stomach and intestinal canal may set up irritation. It is perfectly true both horses and mules can eat uncrushed maize, but it is a heavy demand to make on their grinding apparatus.

Corn crushing is distinctly valuable with old animals, or those with defective teeth, or in a condition of debility, as it saves labour and ensures a breaking up of the grain.

Linseed requires some form of preparation, either by boiling or prolonged steeping, to render it fit for digestion; without this it passes through the body untouched.

'Gram,' as used in certain parts of India, must either be crushed or soaked. 'Oorud' and 'coolthie,' feeding grains used in the South of India, require boiling, and potatoes are better boiled than raw. In these special instances boiling is necessary, yet as a practice we are opposed to boiled foods for horses, though many authorities in the profession hold a different view. In our experience they are productive of colic with its sequelæ, for the reason that the soft pulpy mass admits of being eaten very quickly, and this with a greedy feeder spells colic.

Greedy feeding among horses is very common, and as a cause of disease is tolerably frequent. It is inviting a greedy feeder to contract trouble unless the food partaken of is properly prepared, and the preparation it requires is to be wetted and thoroughly mixed with hay chaff; this ensures mastication, but if the chaff be added to a dry feed the animal very soon learns to blow it away and deal solely with the corn.

The most thorough manner of defeating a greedy feeder is to use a flat surface to feed from, and spread the food in a thin layer all over it; this absolutely prevents 'bolting.' The lid of a box does very well, but any contrivance which complies with the above principle may be adopted. It is evident a greedy feeder should never be fed out of a nose-bag.

If a quantity of 'green meat' be given for the first time without being mixed with a certain amount of dry hay disease will arise; it is always advisable, until tolerance

of green food has become established, to ensure that hay is mixed with it in order to prevent tympanites.

Linseed and other cakes require to be prepared by breaking before being given to stock; if not broken to a proper size there is waste and loss of digestibility.

Grorse shoots, if used as food, should be ground by a special machine which crushes all the prickles; without this precaution the mouth is liable to be injured.

#### VARIOUS ARTICLES OF FOOD.

##### GRASS.

Grass is the natural food of herbivora, and from this fact requires somewhat detailed consideration.

Grasses are very widely distributed, they include botanically something more than the ordinary grass of the field, for belonging to the Natural Order *Gramineæ* are oats, wheat, rye, millet, sugar-cane, and bamboo. There are certain plants to which the term grass is applied which are not grasses, such as cotton-grass, goose-grass, scurvy-grass scorpion-grass, cow-grass, and others; some of these are weeds, and none are grasses.

Amongst grasses have also been included in the mind of the public such plants as lucerne, clover, vetches, etc., which belong to the leguminous natural order, and are only termed grasses from custom; to these the term artificial grasses is applied. There are certain plants mistaken for grasses which belong to other natural orders, for instance Rushes and Sedges.

Of the true grasses all are not of equal value for feeding purposes, in fact some are pernicious weeds, and others may be classified as inferior.

*Grass Land* can by skill in agriculture be artificially prepared, but a great deal of that in England and Ireland has from time immemorial been devoted to grass, and some of these pastures are probably the richest in Europe. Grass land may be temporary or permanent depending upon whether it is wholly given up to grass, or whether it

is periodically ploughed and placed under cultivation. The nature of the herbage in these two cases is not quite the same.

Another and important division of grass lands is into those which are grazed and never mown, and those which are mown and not grazed; the first is known as pasture, the second as meadow land. In these two cases also the grasses found are observed to differ considerably, and in addition the soil of the two lands is not the same, for the one has had the benefit of the excreta of the animals grazing on it, and thus a good deal of its nourishment returned, while the other suffers a direct loss in its hay crop, which can only be returned by manuring.

Meadow lands will vary greatly from year to year, depending upon the nature of the fertilizer which has been applied. There is a constant struggle for existence among plants, some flourish under one and some under another manure, some withstand drought, others droop and die; these and other conditions determine whether the plant shall survive or not. This has been clearly demonstrated in the classical experiments carried on at Rothamsted, where twenty different plots laid down to grass have been carefully observed for thirty years, and the influence of the above factors considered.

These observations show a tendency in the reduction of the number of species as the result of the struggle for existence, though the total amount of grass yielded has been actually higher than when the number of specimens was greatest.

The following were found to be the principal surviving grasses after many years, on the old meadow land at Rothamsted, the hay on which had been regularly cut:—

Common bent	Cocksfoot
Meadow foxtail	Sheep's fescue
Sweet vernal	Yorkshire fog
Tall oat grass	Perennial rye grass
Yellow oat grass	Smooth stalked meadow grass
Downy oat grass	Rough stalked     "     "

All the above were invariably found on each plot under observation, but there were four grasses not so regularly distributed, yet very frequently found viz. :—

Quaking grass	Crested dogstail
Soft brome	Meadow fescue

Leguminous plants, the so-called artificial grasses, were also counted in the experiment, and it was found in the course of many years they were reduced to

Meadow vetchling	Red clover
Birdsfoot trefoil	White „

In addition to the above the number of miscellaneous plants, mostly weeds, were counted, and fifty-nine varieties were found, though not on each plot, such as sorrel, yarrow, buttercup, chickweed, plantain, dandelion, etc. The above, then, represents the grasses, leguminous plants, and weeds, found on old meadow land.

Turning to old pasture land, a larger variety of grasses and leguminous plants is found. In the following table is given those growing in many prime old pastures :—

Marsh bent	Sheep's fescue
Fiorin	Meadow fescue
Fine bent	Yorkshire fog
Meadow foxtail	Meadow barley
Sweet scented vernal	Rye grass
False oat	Timothy
Yellow oat	Annual meadow grass
Dogstail	Smooth stalked meadow grass
Cocksfoot	Rough „ „ „
Spiked fescue	Bearded wheat grass

The leguminous plants found were

Meadow vetchling	Purple clover
Birdsfoot trefoil	White „
Yellow suckling clover	

The miscellaneous plants and weeds were numerous, of



which buttercups, plantains, docks and chickweed were the most common.\*

The interest attached to these observations is twofold, it is necessary we should understand what grasses are from various circumstances able to survive in the struggle for existence, and it is certainly desirable that we should know, with some degree of exactitude, the botanical varieties of grasses found in some of the richest grass lands in the world, where cattle fatten so rapidly, that with judicious management no less than two sets may be fattened during the one season.

The exhaustion of the soil which arises from growing grass for hay is considerable. The Rothamsted experiments show that hay removes as much nitrogen from the soil as either wheat or barley, and more potash, soda, lime, magnesia, sulphuric acid, and chlorine than either of these cereals. The only mineral matter which wheat and barley assimilate in larger amounts than grasses, is phosphoric acid and silica.

Potash is the mineral of which grass so largely robs the soil, and in the Rothamsted experiments it was found that potash as a manure, influenced the quantity and character of the herbage more than any other mineral.

They also show that the exhaustion of grass land which is fed and not mown, is very much less than that of meadow land, as in grazing so much is returned by the animals through the excreta. This, however, is not so evident where the land is grazed by dairy stock, which do not return to the soil the mineral matter which is used up in the production of milk.

The only grass lands at present spoken of are pastures and meadows, but in addition to these there are water meadows, principally found in the south and west of England, which are periodically flooded. The grasses found on them are not of good quality, but the flooding

\* I am indebted to Dr. Fream's 'Elements of Agriculture' for the information regarding the grasses of the Rothamsted meadows, and those of the best pasture-lands of England.

promotes a winter growth, and such meadows, though furnishing hay of a poor kind, afford grazing to both sheep and cattle at various times of the year. In seasons of drought they are of the greatest value to the feeder of stock.

Water meadow grasses have also been estimated and have been found to consist mainly of Yorkshire fog which may form as much as 34 per cent. of the total, the remainder being inferior grasses excepting Rye grass which forms 12 per cent.

#### GRAZING AND PASTURING.

One of the most difficult problems in stock management is the selection of store cattle, and the next difficult one is to know how to graze them properly and to the best advantage.

Store cattle and sheep must be purchased suitable to the class of pasture; both the stock and pasture must suit each other. To place poor animals on a rich pasture, or big animals on a poor pasture, only means loss. Even where the suitability of stock to pasture is ensured, yet the grazier's watchful and trained eye is necessary, for the turning of animals out to grass with the idea of fattening them for sale is not as simple as it sounds. It is, indeed, a question requiring years of experience, and an intimate knowledge of cattle and pastures. There are certain pastures which are of first-class or prime quality for cattle, and others for sheep, and so well is this known that in some parts of the country the two are kept quite separate. Owing to the difference in their habit of grazing, that which would be a first-class sheep pasture only becomes a second-class pasture for cattle. Cattle which have not been starved during the winter make the most remarkable improvement when turned out to grass in the spring; it is even said that during the first four or five weeks they will add from one-sixth to one-fifth increase in body weight as the result of grazing.

It is essential they should not be turned out until the grass is sufficiently long, and in this respect there is a great difference between old and new pastures. There is a time in new pastures when the grass grows with remarkable rapidity, the sooner this is eaten down the better or it becomes rank. Old pastures are later in coming forward, and when neglected they frequently contain weeds which are largely absent from new pastures; yet there is something in the quality of the grass on old pasture land which gives it the most remarkable fattening properties.

A very important point in the grazing of both cattle and sheep, is that they should be frequently moved so as to afford a fresh 'bite.' It is this change in the herbage which is found so beneficial, and it should be effected about every fortnight, if possible arranging that they pass to stronger rather than poorer pastures. Where large numbers of stock in different conditions are being grazed, it is well to allow the most forward in condition to have the first 'bite,' and when they are changed to follow on with the poorer cattle, and finally with sheep if considered desirable.

Sheep graze much closer than cattle, and in sheep pastures this close grazing is encouraged, as it prevents the seeding of worthless grasses, and keeps the herbage fine and the pastures sweet.

Excepting on pastures reserved exclusively for sheep, it is well to turn in a certain number of store cattle with the sheep in order to prevent the finer bottom grasses disappearing, and only the coarser ones being left.

This brings us to a consideration of heavy and light stocking of pastures, a question by no means settled among graziers, for those who favour light stocking, while recognising it is destructive to the grass by the amount wasted in being trodden underfoot, yet favour the custom, as it is remunerative when the day of sale arrives. Those favouring heavy stocking believe that in this way the finer grasses do not suffer, but that both fine and coarse grasses get regularly eaten down. Finally, there is a third school of graziers who advocate mixed stocking, such as has been

previously mentioned, where the advanced bullock is followed by the lean one, and this again by sheep; between these three there are no uneaten patches left, for what one rejects the others take.

In mixed stocking it is disadvantageous to pasture horses with cattle, as owing to their different temperament they are a disturbing and annoying element.

It is generally believed that a fattening ox requires on moderate pastures two acres, though on prime pastures one acre is more than sufficient. With regard to the number of sheep no definite statement can be made, as so much depends upon the character of the pasture.

Stating the case broadly, rich pastures should be reserved for fattening stock which is being rapidly brought forward for the butcher, while newer and less rich pastures, which are generally placed on higher ground and away from river valleys, are employed for the store cattle. Sheep may conveniently be pastured on upland pastures, which are less rich and where they do equally well.

There are certain pastures where suitable cattle fatten on grass alone, and, as mentioned previously, on some of the prime pastures two lots of cattle can be grass fattened in one season.

If possible, pastures should not be grazed during wet weather, as it may prove destructive to them. Pastures naturally wet should certainly be avoided for sheep during the autumn, when fluke disease is liable to be contracted, and under any circumstances such lands may lead to 'foot-rot.' Animals that have to be pastured on meadows affected with fluke should receive a proportion of dry food daily.

Bearing in mind that any wet land may get infected with fluke, it is desirable, where wet pastures have to be used, and draining and other measures have done all they can for them, to reserve the driest portion on which no other sheep have grazed that year for the autumn feeding, the wettest portions being hurdled off. The risk of infection is greatly minimized by not allowing the sheep to bite too

closely, and if the pasture be suspected an allowance of dry food must be made.

We have previously alluded to the frequency of tympanites among cattle turned out to graze for the first time. The best way to prevent this is to begin by only turning them out for a short time, or by feeding the animals before they are turned out, which may prevent them from eating to excess. Clover fields are particularly dangerous, and cattle turned on to these should be watched, so as to keep them on the move and not allow them to gorge themselves.

Pastures in England are ready for stock about the end of April or even earlier; in Scotland it is later, not before the middle of May, and the grazing season is shorter seldom extending beyond the month of September. The system pursued in Scotland is also different, as old pasture lands do not exist owing to the area under cultivation; the pasturage principally consists of cultivated grasses and clover, and on this the young and fattening stock is placed.

#### *Soiling.*

Agriculturists are now looking with some favour on the system of 'soiling' as applied to cattle; it has been for many years used for cattle in Scotland and for horses in England, especially for hunters thrown out of work after the season. It is urged that by 'soiling' cattle instead of grazing them, viz. by mowing the grass and feeding the animals in sheds or enclosures, twice as many stock may be fed on a given space. The reasons of this are that there is less damage done to the pastures as there is no treading down and close feeding; further, the cattle through freedom from disturbance, shelter in the event of bad weather, and the saving of labour in collecting their own food, require less than when fattened in the usual manner.

It is also argued that the manure from them is more valuable than when simply dropped about the field; finally,

that there is economy in cake and meal feeding, as a definite quantity can be given without waste.

If the system of 'soiling' be carried out, it is absolutely essential the grass should be mown and brought to the animals twice a day, otherwise if left in a heap it will ferment and be productive of disease. Care also should be taken that no excess of grass is given, it all should be cleared up, and the animals fed four times a day.

If soiling has its advantages, it is not without the disadvantage of requiring more labour to carry it out, and this means expense.

Soiling can only be satisfactorily effected on good land, and where careful provision has been made beforehand as to the amount of succulent food required. It has been authoritatively stated that each head of cattle requires from one and a half to two square rods of land a day, and this presupposes that the amount of whatever material is used in soiling, be it grass, oats, barley, etc., is calculated beforehand with some degree of nicety, in order that it may be fit to cut at the right moment, and last a given time.

Grass after attaining a certain length becomes stationary, but if cut there is a constant state of growth; this fact is counted upon by those who advocate the system of soiling as an economical measure.

Sheep like cattle and horses, may be 'soiled' during the summer.

*Purging Pastures.*—Some pastures cause cattle to purge; the cause of this was inquired into by Dr. Voelcker many years ago, and was found to be due to immature herbage. Grass in a young and growing condition contains a considerable amount of soluble mineral matter and organic acids, such as malic, citric, tartaric, etc., and it is to these the purging is due.

Grass acts as a laxative to horses, and it also possesses diuretic properties. The change from hay to green food is greatly appreciated by all animals, and is certainly beneficial, but it invariably produces purging to begin with.

*Grass as a Diet.*—It is impossible to get anything like

very hard work out of a grass-fed horse in England, even when corn forms part of the ration; this may be owing to the laxative properties of grass. It is quite impossible to get anything but the slowest work out of the entirely grass-fed horse.

It at first sight seems strange that the practice of Africa, India, and America, should prove useless in Europe. In all these continents horses are fed, in some cases entirely, on the ordinary grass of the country, and both thrive and work well. The Boer pony gets little else but grass, and a handful of Indian corn when obtainable, and he can go all day. The explanation appears to lie in the fact that the grass of these continents is far dryer than that of northern Europe, and that less has to be consumed to furnish the needful amount of nourishment. Further, the individual grasses may contain more nutriment; for instance, the unsavoury-looking bundle of grass in India with adherent dirt, consists very largely of young underground stems, very succulent and full of nourishment. There appears no doubt also that the grass of South Africa is highly nutritious, and that on it alone both horses and oxen perform very hard work, the latter in fact get nothing else.

The average percentage composition of pasture grasses, according to Wolff, is as follows:—

Water	...	...	...	...	...	70·0
Proteids	...	...	...	...	...	3·4
Fat	...	...	...	...	...	1·0
Carbo-hydrates	...	...	...	...	...	13·4
Cellulose	...	...	...	...	...	10·1
Ash	...	...	...	...	...	2·1

The difference between this average sample and the composition of rich meadow grass, lies mainly in the proteids which are higher in the latter. The proportion of cellulose found in grass depends upon its age. In young grass the amount is small, but it gradually increases as the plant approaches maturity, while the proteid becomes less as the plant ripens.

*Meadow and Pasture Grasses.*

From the Rothamsted experiments, previously quoted, the nature of the grasses found in hay may be known. Those most appreciated for pasture and hay production are as follows :—

Foxtail	Sheep's fescue
Sweet vernal	Hard „
Dogstail	Meadow „
Italian rye grass	Tall „
Perennial rye grass	Smooth stalked meadow grass
Timothy	Rough „ „ „
Cocksfoot	Yellow oat grass

The following grasses are worthless, and some of them actual pests from an agricultural point of view :—

Hair grass	Brome grass
False oat grass	Yorkshire fog
False brome	Barley grass
Quaking grass	Couch grass

The fact should not be lost sight of, that what is an inferior grass in one part of the world may occupy a very different position in another; further, any hard and fast line between good, inferior and bad grasses should be drawn with great discrimination, or it is likely to unduly influence one's judgment in the selection of hay.

With us Yorkshire fog is a valueless grass and regarded as a weed; the New Zealand farmer, on the other hand, greatly appreciates it. The much-dreaded Couch grass is in certain parts of the Continent considered a valuable food. Smooth-stalked meadow grass with us does not occupy a high position, some even consider it very inferior, in America it constitutes the celebrated Kentucky Blue grass. What, therefore, may be an inferior grass on one soil or in one part of the world, may in another be valuable.

The influence of soil should not be lost sight of in



selecting seed for laying down land to pastures; the best grasses if planted in unsuitable soil become useless. Besides, there are gradual changes occurring in soils, which in course of years enable them to bear grasses which they could not carry when the land was first laid down to grass. See Soils.

**MEADOW FOXTAIL**, *Alopecurus pratensis* (Fig. 53).—This is an early grass, and affords good grazing before the others are ready. It supplies abundant forage through its large bottom growth. It is wonderfully hardy, and excepting on light soil, where it tends to die out, seems to flourish almost anywhere.

A member of the same family, Slender Foxtail (Black Bent), *A. Agrestis*, also known as 'hunger weed,' is a pernicious weed which mainly invades corn-fields.

**SWEET VERNAL**, *Anthoxanthum odoratum* (Fig. 54).—This shares with Meadow Foxtail the distinction of being a very early grass. It is mainly appreciated for its peculiar fragrance, which may be perceived on chewing the stalk, and is said to give the odour associated with new hay. This grass does not contribute to any important extent to hay, it is far too scanty, but as a tonic or stomachic it may be useful.

**CRESTED DOGSTAIL**, *Cynosurus cristatus* (Fig. 55).—This is not a particularly valuable grass, excepting for pastures where it is much liked by sheep. It is hardy and widely distributed, but, probably from the fact that it does not contribute much to the hay-crop, it is not greatly in public favour.

**COCKSFOOT**, *Dactylis glomerata* (Fig. 56).—This is a plant regarded by some as the most valuable of all grasses owing to its nutritious character, rapid growth, and hardy nature. On good, rich soil it is most abundant. It should be cut, if possible, before flowering, owing to the fibrous character of the stems which increases as the plant gets older.

**SHEEP'S FESCUE**, *Festuca ovina* (Fig. 57).—This is a valuable pasture grass, but is of little use for hay. It is

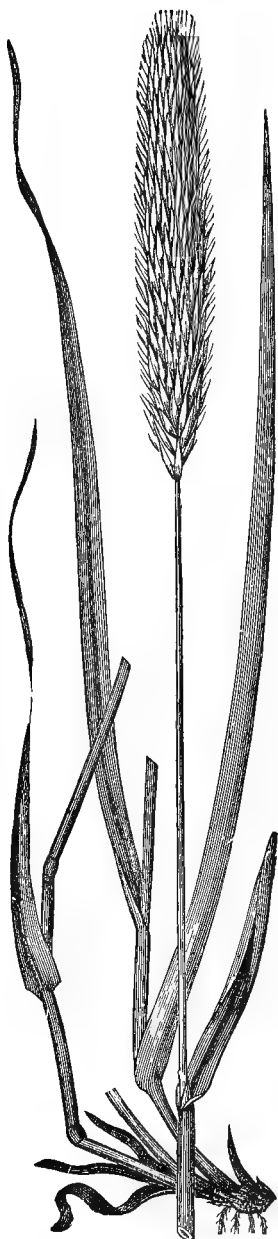

Fig. 53.—Meadow foxtail (Dickson).

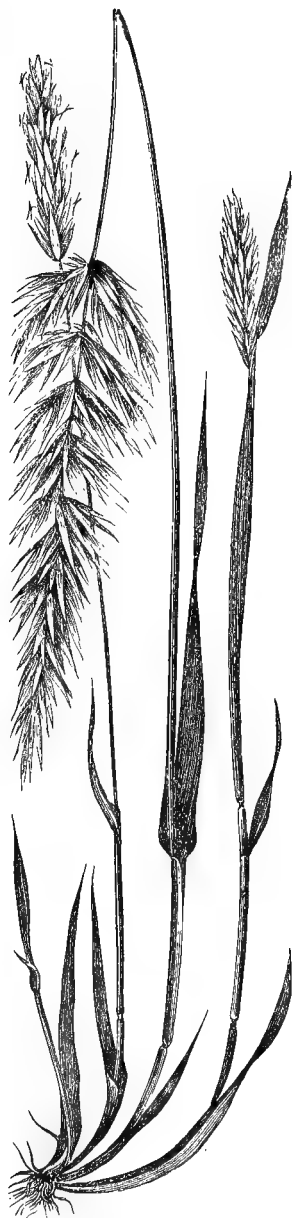

Fig. 54.—Sweet vernal (Dickson).



Fig. 55.—Crested dogtail (Dickson).

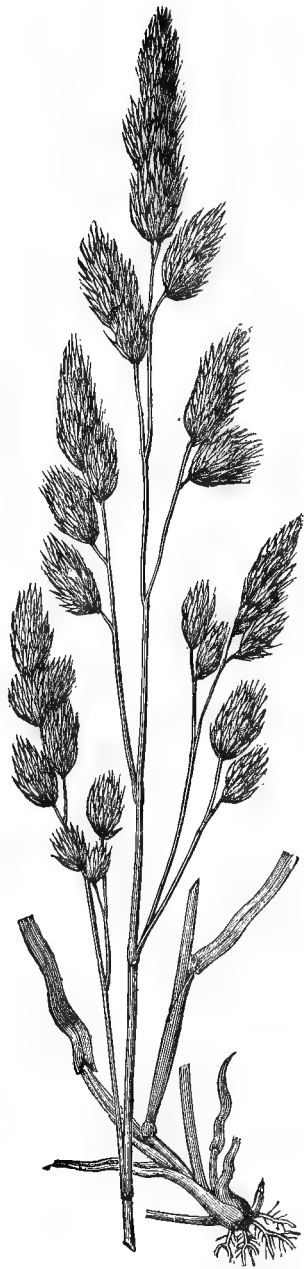

Fig. 56.—Cocksfoot (Dickson).

found on high, dry, poor, sandy soil, and it is generally considered that where it grows such soil is healthy for sheep. The leaf is very fine and slender, and the plant forms a close turf. The fescues are divided into two groups, narrow and broad leaved; Sheep's Fescue is the type of narrow-leaved fescues.

**HARD FESCUE**, *Festuca duriuscula* (Fig. 58).—This is an excellent forage plant, both for pasture and hay. For pasture purposes it is appreciated by all stock, particularly sheep. It is said that hay in which it is found is generally of superior quality. It is a wonderfully hardy grass, and resists drought.

**MEADOW FESCUE**, *Festuca pratensis* (Fig. 59).—This is the type of broad-leaved fescues. By some it is considered the most valuable of all grasses, not only on account of its use in the pasture, but also from its excellent yield of hay. It thrives best on a moist soil, and is perfectly adapted for irrigated meadows.

**TALL FESCUE**, *Festuca elatior* (Fig. 60).—This grass may grow to a height of six feet, and from its coarseness is considered by some as unfit for hay. It yields largely, and is best suited to damp soils, especially water-courses.

**ITALIAN RYE GRASS**, *Lolium italicum* (Fig. 61).—This is a heavily-yielding, highly nutritious grass, much appreciated by herbivora, especially dairy stock. It gives an excellent flavour to both milk and butter. It is a biennial, and is therefore unfit for permanent pastures, and is exclusively employed for alternate husbandry. Under the influence of liquid manures it yields abundantly, and in all circumstances it requires a damp soil.

**PERENNIAL RYE GRASS**, *Lolium perenne* (Fig. 62).—This is a smaller plant than Italian, essentially suited for pasture purpose. Treading by live stock does it no harm, in fact, appears to encourage its spread. It is more valuable as a pasture than as a hay grass, but always requires a generous soil. By some its nutritive properties have been placed next to Foxtail.

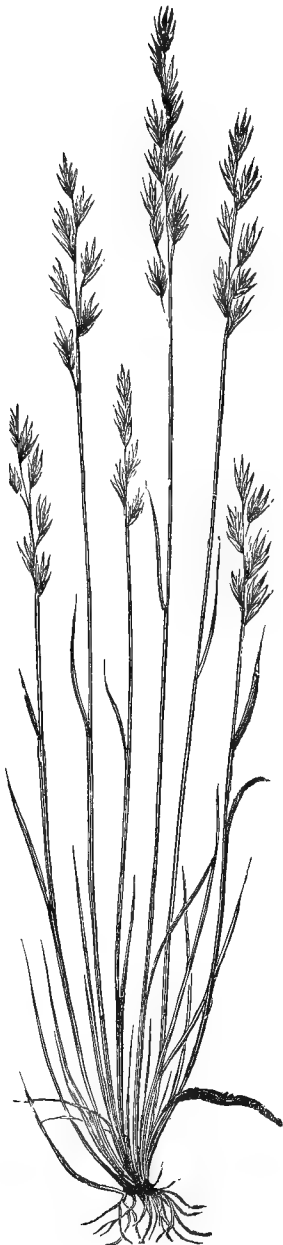

Fig. 57.—Sheep's fescue (Dickson).



Fig. 58.—Hard fescue (Dickson).



Fig. 59.—Meadow fescue (Dickson).



Fig. 60.—Tall fescue (Dickson).

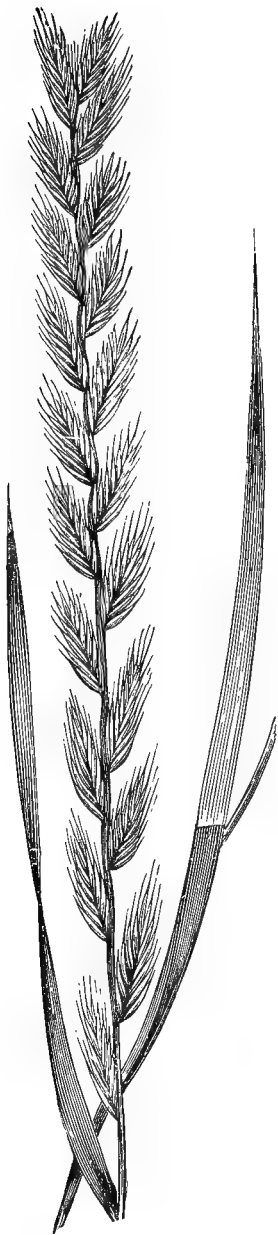

Fig. 61.—Italian rye grass  
(Dickson).



Fig. 62.—Perennial rye grass  
(Dickson).

MEADOW CATSTAIL OR TIMOTHY, *Phleum pratense* (Fig. 63).—This is a very coarse-growing grass, yielding an abundant and excellent hay crop, but not possessing the same value for pasture, owing to its liability to be uprooted in grazing, due to the strength of its stems and the tufts or bunches it grows in. It is a most nutritious grass, very hard, much liked by horses and cattle, and thrives on all but light, sandy soils, though it naturally produces best on clay.

It should be cut before flowering, owing to the fibrous nature of its stems, and is capable of yielding an abundant second crop.

SMOOTH-STALKED MEADOW GRASS, *Poa pratensis* (Fig. 64).—This is an early grass, and on this account appreciated; taken all round it does not rank high, though it is a constituent of all good pastures. It flourishes best on a dry soil.

ROUGH-STALKED MEADOW GRASS, *Poa trivialis* (Fig. 65).—Is a valuable pasture plant, found in all rich old pastures, but prefers a shady moist place. By some it is considered the most valuable of the *Poa* group, its young rich herbage being greatly relished by all stock.

YELLOW OR GOLDEN OAT GRASS, *Avena flavescens* (Fig. 66).—This is a valuable forage grass found in pastures, meadows, and water meadows; it is especially good on calcareous soils.

#### HAY.

To make good hay certain rules must be observed. The first is that the grass must not be cut too late; in order to secure the full value of hay, the grass must not reach maturity, or the nutrient matters in the stem pass into the seed with consequent loss of proteid. In the growing plant the valuable carbohydrates become less owing to their conversion into cellulose, so that the older the plant, the more cellulose and the less starch and sugar substances it contains.

The value of hay depends upon its richness in proteid and its poverty in cellulose, though as Wolff points out it





Fig. 63.—Timothy, or Catstail (Dickson).



Fig. 64.—Smooth-stalked meadow grass (Dickson).



Fig. 65.—Rough-stalked meadow grass (Dickson).



Fig. 66.—Golden oat grass (Dickson).

often depends upon its tenderness, flavour, and aroma, rather than on its chemical composition. The latter is found to vary somewhat considerably, depending probably on the nature of the plants of which it is composed. It is placed beyond all doubt that the digestibility of hay cut late is considerably reduced.

The next rule in hay-making is that the grass once cut should remain as short a time as possible in the field. The sole object of exposure is to dry it, and reduce the 70 per cent. moisture to 16 per cent. or 14 per cent.; the quicker this can be done the better, and to hasten it the grass is frequently turned and shaken. During this process it should be handled with care, to avoid damaging the waxy covering on the leaves and stems.

The grass is cocked at night, not only to protect it from any rain and dew, but to give the ground an opportunity of drying, so that the next day's operations may be more effectively carried out.

With favourable weather hay can be 'carried' in three days; it should not be left in the sun longer than necessary, or it will become bleached, lose its flavour, and deteriorate.

The influence of rain is very marked, the most valuable constituents in hay are soluble in water, and these are washed out of it by rain.

From a veterinary point of view these are the two important points in the curing of hay.

Hay when ricked undergoes further changes of the nature of fermentation, which improves its flavour and digestibility. If the heating is carried beyond a certain point, as in hay stacked before being properly dried, there is a great loss of proteids and soluble carbo-hydrates, while aldehyde and acetic acid are formed. At the same time there is a change in colour, the hay darkens, and if carried to an extreme point turns a dark-brown colour, known as *mow-burned*, due to the temperature within the rick; it may even end in spontaneous combustion should air be able to find its way in.

In England the greatest care is taken in saving hay, but in Scotland the crop remains out much longer, and in Ireland is exposed to the elements for a considerable time. The result is that both these countries produce a hay which bears an indifferent reputation.

*Aftermath* is the second or third cutting of hay, it is greener, softer, more flexible, and there is an absence of flowering heads. It is also deficient in the aroma of good hay, and if badly saved—and it is a difficult crop to save properly—it may be entirely wanting in perfume.

Owing to the young condition of the grasses composing aftermath, it is much more readily damaged by rain, and more liable to fermentation than the first cutting. In consequence it is often completely ruined, or if saved with difficulty becomes mouldy, and is rejected by stock. If, on the other hand, the weather is favourable for its curing, it is more digestible than ordinary hay, and makes good fodder. It is considered by some that aftermath is more liable to produce tympanites than ordinary hay.

The following analysis of different qualities of hay are given by Wolff; but in comparing these it must be remembered that there is hardly any food substance liable to such variation in digestibility, experimental inquiry having shown the digestibility of the dry matter of hay as likely to vary from 6 per cent. to 20 per cent.

	Meadow Hay.					After- math.
	Poor.	Better.	Average.	Very Good.	Extremely Good.	
Water ...	14·3	14·3	14·3	15·0	16·0	14·3
Proteids ...	7·5	9·2	9·7	11·7	13·5	11·7
Fat ...	1·5	2·0	2·5	2·8	3·0	3·1
Carbo- hydrates	38·2	39·7	41·4	41·6	40·4	42·3
Cellulose ...	33·5	29·2	26·3	21·9	19·3	22·0
Salts ...	5·0	5·4	6·2	7·0	7·7	6·6

*Varieties of Hay.*—It is usual to describe hay as being of three kinds, upland, meadow, and water meadow, and distinctions have been drawn between these for the purpose of identification ; it is doubtful whether anyone but an expert salesman could tell the difference between upland and meadow hay, and even then it would largely be based on his knowledge of the locality where the hay was grown. Further, if they are both good there is nothing to choose between them.

Water meadow hay is not considered good as it is wanting in aroma, mixed with water plants, and contains poorer grasses of little feeding value.

Good hay should be hard, sweet, clean, free from dust and mildew, of a pale green colour if well saved, with an aromatic odour, and the best grasses should predominate. It should be about one year old.

Whatever departure there is from this standard will consign hay to the second or third quality, the latter giving evidence of a departure from that of second quality and yet containing nothing positively harmful. It may be without odour, brittle on account of age and in consequence dusty ; or soft to the feel due to inferior grasses, but there is nothing in these to hurt an animal, though there is a great difference in the market and feeding value.

Bad hay on the other hand may be considered such as is mildewed, discoloured, and obviously unfit for food from various causes.

No hard and fast rule can be made in connection with the qualities of hay, and only experience can help the mind to group them according to their value. There may be an overlapping of the classes as they insensibly merge into each other, but as classes they must remain distinct ; there is nothing in second or third quality hay to prevent it being used, but for valuable animals the last would be most undesirable.

This distinction of hay into different qualities is given to enable a judgment to be formed as to whether it is fit for

food, and also whether there is full value for the money; in judging both these points if the hay be of home manufacture, the nature of the past season must be taken into account.

A good deal of hay is imported into the United Kingdom. There is nothing better than well saved Canadian hay consisting of rye grass and timothy.

In forming a judgment of the quality of hay by the grasses present, it is essential to bear in mind that the existence of an indifferent grass here and there should not condemn the whole; indifferent grasses may occasionally be mixed up with excellent hay.

*New and Old Hay.*—In the trade hay is considered new up to 29th September, with others it is considered new until it is a year old. At times it becomes a matter of some importance to determine whether hay is old or new. It is usual to regard new hay as greener, but this may be very misleading in a well saved sample. New hay contains more moisture than old, about 2 to 3 per cent. more, and this may be used as a test in cases of doubt, but when working so close as 2 to 3 per cent. great accuracy is required, such as is only to be obtained in a chemical laboratory.

The chief characteristic differences between old and new hay can be determined by the appearance of a truss. When hay is ricked it undergoes compression, and the stack gradually sinks under the tons of pressure imposed, until no further shrinkage occurs. This pressure causes the fibres of the hay to lie very close, the truss is very compact, solid, and hard, and when opened a layer an inch or two in thickness may be rolled up like paper. This can never be done with new hay, consolidation has not had time to occur, and the truss on being opened presents rather a tangled mass, very different to the firm condition of old hay.

The length of time that hay retains its nutritive properties is two years from the time of cutting; after that it deteriorates, becomes dusty, brittle, and loses both its

nutritive properties and its digestibility, at the same time there is a loss of flavour and aroma. Whether this deterioration is associated with chemical changes in the dry matter is unknown, but it is most likely. The disadvantage of feeding on new hay has previously been dealt with (see p. 157).

Hay may be badly saved, dusty, mow-burned, or musty.

In *Badly saved hay* the damage may be slight, such as results from a single shower of rain, or so severe through floods, as to render the hay useless for anything but bedding. Excessive bleaching indicates it has been too long exposed to the sun, resulting in the destruction of the chlorophyll. Discoloured, dirty looking hay, tells its story of rain. Flowering heads too advanced proclaim late cutting, and consequent loss of nutriment.

*Dusty hay* may result from too long exposure to the sun, or to gradual decay in the rick the result of age, or it may be due to the attacks of insects, such as have been described on p. 168.

*Mow-burned hay* is the result of overheating in the stack, due to being ricked before it is sufficiently dry. There are various degrees from slight to severe, the latter being dark brown in colour with a pungent odour, while the hay is dry and brittle.

Slightly mow-burned hay is not at first objected to by some horses, but in a few days they reject it. Slightly affected it does no harm, but severely affected hay acts as a diuretic, producing thirst and a general falling off in condition.

*Musty hay* is very evident to the senses, it is due to ricking while wet, or to getting wet after being stacked. The fungi associated with it have already been noticed (p. 166). Slightly mouldy hay given occasionally has not appeared to produce harm. Very often salt is added to it, which may help to counteract any ill effects; prolonged use is not only dangerous but represents a serious loss of nourishment, and is therefore unprofitable. Should circum-

stances necessitate the use of musty hay, it should be opened out, and dried, well beaten and shaken to get rid of the spores, and dressed with a solution of common salt. Its action should be carefully watched.

The *Amount of Hay given* to horses varies with the nature of their work and the other food they are obtaining. It is found when horses are allowed an unlimited amount of corn they only consume a small amount of hay. Race-horses, for instance, will not take more than five or six pounds daily.

Large draught horses may consume as much as eighteen or twenty pounds a day; horses of average size and at ordinary work consume about twelve pounds a day.

The faster the work the more corn and less hay required, for the physiological reason that the action of the lungs and diaphragm must not be interfered with.

Where a small amount of hay is consumed it may be given long, but as a general rule it may be stated that all hay should as a measure of economy be chaffed, and mixed with the grain. In this way the saving of waste is considerable.

For horses intended for fast work no hay should be given before going out, the mixing of chaffed hay with their corn, excepting in the form of a double handful to ensure mastication, would under these circumstances be wrong. For slow working horses every 'feed' should be a mixed one of corn and hay chaff.

When long hay is used it should be given after work, and the bulk of it at night so as to ensure occupation for the horses.

#### ARTIFICIAL GRASSES.

These constitute a large and important class of feeding material, all belonging to the natural order *Leguminosæ*, and therefore not grasses though commonly spoken of as such.

The following list comprises those used for feeding purposes :—



TRUE CLOVERS ( <i>Trifolium</i> ).	ALLIED CLOVERS ( <i>Medicago</i> ).
Red or Broad Clover	Trefoil, Yellow Clover, or Hop trefoil
White or Dutch Clover	Lucerne
Swedish or Alsike Clover	Sainfoin
Crimson or Italian Clover	Vetches
Yellow Suckling Clover	Birdsfoot trefoil
	Kidney vetch
	Bokhara clover
	Lupines
	Furze, Gorse or Whin
	Serradella



Fig. 67.—Red Clover (Freem).



Fig. 68.—White Clover (Freem).

RED OR BROAD CLOVER, *Trifolium pratense* (Fig. 67).—Grows on almost any soil, but only lasts two years. It yields an excellent hay, but is liable to 'clover sickness' (see p. 167). There is a variety of it known as *Cow grass* which is much less liable, but it only yields one crop instead of the two yielded by red clover, though it is suitable for permanent pastures which the latter is not.

WHITE OR DUTCH CLOVER, *Trifolium repens* (Fig. 68).—This is a perennial plant found in prime pastures, it is

so short that it is unprofitable for hay, but it is especially valuable for fattening sheep.

ALSIKE OR SWEDISH CLOVER, *T. hybridum*.—Grows everywhere, it is a valuable pasture plant, and is not liable to sickness; its flowering head is light pink in colour.

CRIMSON OR ITALIAN CLOVER, *T. incarnatum* (Fig. 69).—Is a well-known forage plant but somewhat late, and it only affords a single cutting.

YELLOW SUCKLING CLOVER, *T. minus* (Fig. 70).—A useful plant though small, in good land it produces excellent herbage, and grown with rye grass it makes good hay.



Fig. 69.—Crimson Clover (Fream).



Fig. 70.—Yellow Suckling Clover (Fream).

TREFOIL, YELLOW CLOVER, OR HOP TREFOIL, *Medicago lupulina* (Fig. 71).—This is not much appreciated for feeding purposes, though in a mixture of other clovers and grasses it is a good fodder plant.

LUCERNE, *M. sativa* (Fig. 72), is an excellent fodder plant, which from the fact of its sending down deep roots is capable of withstanding drought. Under the influence of irrigation in hot climates it yields abundantly, and in temperate climates without irrigation three or four cuttings may be had. It lasts for several years, but will not grow if there is an absence of lime in the soil. It is more com-

monly used for green feeding (soiling), but in suitable climates can be made into hay. In this form, under the name of *Alfalfa*, it is largely imported from the Argentine, Mexico, and the United States.

Both the clovers and lucerne are liable to be attacked by a parasitic plant known as *Dodder*, which clings to it, and winding round the stems to which it attaches itself by suckers, kills the plant by living on its nourishment.

**SAINFOIN**, *Onobrychis sativa* (Fig. 73).—This is a valuable and robust forage plant, hardly affected by drought or by poverty of soil. There are two varieties, the Common and



Fig. 71.—Trefoil (Fream).



Fig. 72.—Lucerne (Fream).

Giant, the former lasts for some years but only yields once a year, the Giant yields twice a year, but it does not last more than two years.

**TARES**, *Vicia sativa* (Fig. 74).—There are two varieties of Tares winter and spring, both are excellent feeding and suitable for all kinds of stock. It is a quick growing crop and suited to almost any soil. The plant should be cut after the pods have formed, but before they have ripened.

**BIRDSFOOT TREFOIL**, *Lotus corniculatus* (Fig. 75).—There are two varieties a greater and lesser. It is a plant of poor soils.



Fig. 73.—Sainfoin (Fream).



Fig. 74.—Tares (Fream).

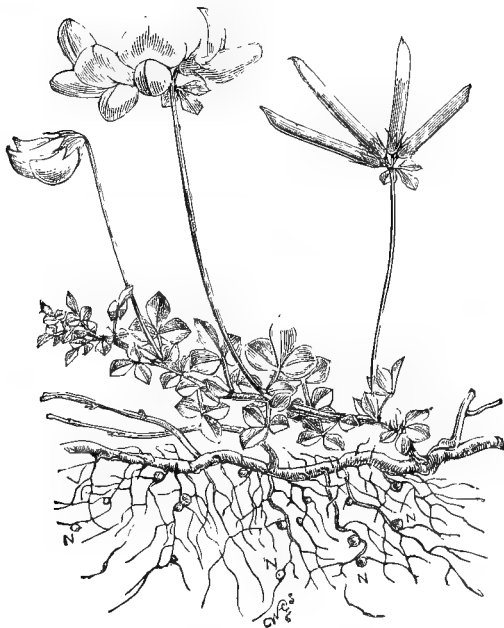

Fig. 75.—Birdsfoot Trefoil (Fream).

KIDNEY VETCH, *Anthyllis vulneraria* (Fig. 76), is also a plant of poor soils, seldom cultivated in England, though within recent years, owing to it withstanding drought and stock liking it, it is being cultivated in certain parts and found to be a good forage plant.

BOKHARA CLOVER, or MELILOT, is occasionally grown as a forage crop ; when in bloom it smells like new mown hay. On the Continent where it has been freely tried it bears an indifferent name, and is believed to be productive of tympanites. One variety, *Melilotus officinalis*, is said to be poisonous.



Fig. 76.—Kidney Vetch (Fream).

LUPINES, though most rich and nourishing, are not cultivated as a forage plant, excepting on the Continent of Europe, owing to their dangerous properties (see p. 194).

SERRADELLA is another forage plant not used in England, but well known on the Continent as an easily digestible fodder, which can be grown on light soils.

FURZE when young is excellent feeding for all stock ; it requires crushing to destroy the prickles, and on this account should not be allowed to grow too strong.

Many of these leguminous crops can be made into hay, but it is difficult, and impossible unless with good weather.

Clover suffers more from rain than even ordinary hay ;

from 25 per cent. to 40 per cent. of its dry substance is soluble in water : as a crop it takes longer to dry than hay, and is therefore more exposed to damage from the weather.

Even with everything in its favour, hay made from the Leguminosæ has a deal of its nutritive matter lost by the physical changes occurring to it as the result of drying. It becomes brittle, the leaves break off and much loss in consequence occurs, as the leaves contain twice the nourishment found in the stalks.

To make good hay the leguminous crops must be cut early, otherwise the stem becomes woody, there is a loss of nourishment, and a considerable reduction in digestibility.

It is an important point in stable economy to bear in mind the brittle nature of leguminous hay, and to avoid the loss of the nutritive leaves through want of care in handling it when being issued for feeding purposes. This loss does not occur to anything like the same extent when it is cut into chaff.

The following analyses by Wolff, of some of the artificial grasses in a green state, give an idea of their composition :

	Red Clover, Full Bloom.	White Clover in Bloom.	Crimson Clover.	Hop Trefoil.	Lucerne just in Bloom.	Sainfoin just in Bloom.	Vetches in Bloom.	Furze.
Water ...	80.4	80.5	81.5	80.0	74.0	81.4	82.0	48.7
Proteids ...	3.0	3.5	2.7	3.5	4.5	4.2	3.5	5.3
Carbo- hydrates	8.9	7.2	7.3	8.2	9.2	7.3	6.6	18.1
Fat ...	0.6	0.8	0.7	0.8	0.8	0.7	0.6	1.1
Cellulose ...	5.8	6.0	6.2	6.0	9.5	5.2	5.5	24.0
Salts ...	1.3	2.0	1.6	1.5	2.0	1.2	1.8	2.8

It has been remarked earlier (p. 205) the care which should be taken in feeding on leguminous plants in a green state, and their liability, especially with animals brought on to them for the first time, to give rise to tympanites, or more serious trouble. In every case to begin with they must be mixed with ordinary hay, and even when the

bowels become tolerant of this gas-producing food, there should be a limit to the amount allowed.

The hay made from these plants is very nutritious. It is seldom well saved, and is consequently frequently found musty. The amount allowed should be carefully regulated, bearing in mind it contains from 12 per cent. to 14 per cent. of proteid. It is best to give it mixed with ordinary hay rather than by itself.

#### ENSILAGE.

It is convenient here to consider a method of saving green food, known from time immemorial, but only within recent years utilized by the agriculturist.

If grass or any of the cereal crops in a green state are dealt with in such a way that air cannot get at them, they may be preserved indefinitely. The process is termed ensilage, the mechanism which holds the fodder is known as a silo, while the product is spoken of either as ensilage or silage.

It is obvious what an advantage this method is in wet seasons, but there is no necessity to confine its use to this, it may be most successfully employed for the saving of green crops like maize, lucerne, and clover, which are only made into hay with difficulty.

By the use of this process, hay which has been damaged by rain and consequently lost its flavour, may be rendered more palatable by converting it into silage; but in making this statement it is well to bear in mind, that valuable as the silo is in improving the flavour of damaged green crops, yet whatever is put into the silo is taken out. It does not convert rubbish into feeding material, but it aids in preventing good feeding material from being converted into rubbish.

Satisfactory silos, whether in the form of pits or stacks, can only be formed when certain definite conditions are followed out, of which the chief is compression, so that the air is excluded. A certain amount of air is imprisoned with the mass when it is being built up, no matter

what compression is adopted, and this air is utilized in producing the needful fermentation; once the oxygen in it is used up in this process, no more should be able to find access.

The chemical changes occurring in silage, were at one time believed to be such that out of useless material useful fodder resulted. This is not so, and even with sound good food there is a loss as the result of this method of preservation; the proteids suffer on the whole a reduction, sometimes a considerable reduction over the amount originally existing. The amides may be increased, due to some of the proteid being converted back; the fat at times is increased, but more often, perhaps, the increase is not a real one, but due to the formation of lactic and other acids, which are taken up by the analytical process employed in extracting the fat; finally the carbohydrates are diminished.

It is calculated that there is an absolute loss of organic substance in silage, amounting to from 15 per cent. to 20 per cent. of the dry matter originally contained in it. This loss occurs principally during the first six months, after that time it becomes much less.

Silage is described as *sweet* or *sour*. The former has an aromatic smell, while sour silage has a powerfully unpleasant odour. These two conditions of silage are produced at will, the question being one of temperature within the silo. At or about 120° F. sweet silage is produced, for the organisms which cause lactic, butyric, and acetic fermentations, are destroyed at this temperature. At a lower temperature sour silage is formed by the production of the acids above mentioned.

If the silo be filled slowly the temperature of the mass can be raised, while if it be quickly filled and closed, the lower temperature favourable for sour silage results.

Sour silage produces a more succulent food, and is generally preferred by animals.

If the temperature in the silo rises above 160° F., the fodder gets burned, it turns very brown, loses a great deal of its proteid substances, and becomes indigestible.



It is well not to give too much silage to begin with, like any other change in food it should be gradually introduced. At Rothamsted it was found that 65 lbs. of red clover sour silage given to fat cattle, was equal in feeding value to 12 lbs. clover hay and 49 lbs. of roots.

#### STRAW.

The cereal straws in use are derived from wheat, oats, rye and barley, while the pulses furnish bean and pea straw.

Straw used as bedding needs no consideration here, the straws now being dealt with are those used for feeding purposes, which should be the best of their kind, and cut at the right time. The earlier straw is cut the more nutriment it contains, if cut when the straw is yellow there is a great proportion of cellulose, and a very serious reduction in proteid, which may fall from 8 per cent. in the young plant to 3 per cent. in the old.

Summer straw is better than winter, it possesses less fibre and more proteid. The one generally preferred for feeding purposes is oat straw, while that of wheat is commonly used as bedding.

Experiments show that from 17 per cent. to 35 per cent. of the proteids in different cereal straws are capable of digestion, and from 50 per cent. to 60 per cent. of the cellulose. This is by no means poor, and some have considered that as feeding material straws have not received sufficient attention. It is certain that on the Continent of Europe, and other parts of the world, they are more appreciated than in England.

Putting the case broadly, it may be said that straw is deficient in proteid, and contains an excess of cellulose. It is of great value in giving bulk to the diet, especially of cattle, and with them is not only useful mechanically in rumination, but is also nutritious.

In parts of India cattle get no other food than the chopped straw of wheat and barley, and on these they do an immense amount of work.

Horses will also do well on chopped straw, but from what has been said, it will be seen that the amount of nutriment it contains must depend very largely on the period at which it is cut.

The straw which presents the largest amount of proteid and the best chemical composition is oat. It is the one generally used for feeding purposes, and some authorities consider it is the most nourishing and best to employ, and infinitely superior to indifferent hay. Next to it comes wheat straw, while the straws of barley and rye are considered indigestible.

Long straw is not much used for the feeding of horses, but chaffed with hay it is a useful and economical addition to the diet of working animals, especially those of the heavier breeds. It can also be employed in the chopped condition mixed with corn, to prevent animals bolting their food.

The straws of leguminous plants are much richer in proteid than that of cereals, but at the same time contain less digestible fibre. Their value for feeding purposes is determined by the period at which they are cut, for the more mature they become the larger the amount of fibre they contain. For feeding purposes pea is preferred to bean straw. The late Dr. Voelcker considered that green oat straw and pea-haulm approached nearest in composition to hay.

In reviewing the straw feeding question and speaking generally, it may be said that it is of far greater value for ruminants than for horses. That horses do well on some straws is undoubted, oat straw is largely used in Australia and South Africa with the best results, but it is cut at the right time with the oats still in the ear, and the straw young, tender and nutritious.

It has been recognised for years that bulky and relatively innutritious fodder is a common cause of 'broken wind' in horses; this condition of the respiratory apparatus appears secondary to digestive derangement, and the cause most commonly alleged as bringing it about is a coarse

innutritious diet, of which straw as met with in England would be typical.

The following table presents an analysis of the various straws :

	Wheat.	Oat.	Pea.	Bean.
Water ... ..	13.55	13.63	14.28	17.28
Proteids ... ..	3.03	4.55	7.56	12.01
Fat ... ..	1.10	1.64	2.17	1.31
Carbo-hydrates ... ..	40.90	36.95	29.39	31.80
Cellulose ... ..	37.48	37.97	42.47	30.67
Salts ... ..	3.94	5.26	4.13	6.39

#### THE GRAINS.

These represent what is known as concentrated food, namely a large amount of nutriment within a small bulk. They are derived from two principal Natural Orders, viz. *Graminæ* and *Leguminosæ*. They are not the natural food of herbivora, but experience shows they are necessary, and quite harmless when given under definite conditions. In fact, without them it would be impossible to obtain from horses the amount of muscular energy they are capable of yielding.

The grains are not all of the same feeding value. There are some like wheat which are avoided, certainly for horses, owing to their liability to disagree excepting in small quantities: further, as a rule it is far too expensive to feed upon. Oats, maize, and barley are found to be grains which perfectly agree with the herbivora, especially when care is taken to bring animals on to them by degrees, when used for the first time.

Oats are by far the most valuable of the grains, and the one most commonly employed, though experience shows that economical feeding is best brought about by a mixture rather than by an individual grain.

From the leguminous group are derived grains containing

a very high proportion of proteid substances, and advantage is taken of this fact by employing them where a rich and highly concentrated food is required for hard worked horses.

From the Natural Order *Linaceæ* is obtained a valuable grain rich in oil and proteid, and largely used in the feeding of cattle, to which it is better adapted than horses owing to its fatty nature.

These three groups contain all the ordinary grains in use for feeding animals, and their individual properties may now be considered.

#### *Oats.*

About sixty varieties of oats are known, of which twelve are in general use, the best being the Potato, Hopetoun, Sand and Early Angus.

There are several gradations of colour, but they may broadly be divided into white and black. The general prejudice is in favour of white oats, the black as a rule are lighter and grown on poorer soil.

Oats require a rich soil, though they can be grown on poor land, with, of course, a marked reduction in their nutritive value.

Oats should be cut before they are fully ripe, and they need to stand some time in the field prior to stacking as they are liable to heat.

After being stacked they require to be kept for about a year before they are fit for food. In the condition known as 'new' they are liable to disagree with horses (p. 157).

Of all grains oats represent the one which is essentially a horse-feeding grain, and this fact is explained by their easy digestibility, and by the well-balanced condition in which the proximate principles exist. The nitrogenous ratio is about the same as in grass, they contain a good but not excessive proportion of nitrogen, and relatively to the other cereals a large proportion of fat. Digestion experiments show that on an average 77 per cent. of the proteids, and 73 per cent. of the nitrogen free extract are digested.

An attempt has been made to show that oats contain a peculiar alkaloid known as *Avenin*, which exercises a stimulating effect on the neuro-muscular system of horses, but there is no evidence of such action, and the alkaloid, which appears to vary considerably in different specimens of oats, cannot explain the well-established fact of the suitability of oats as a food, and their superiority over other feeding grains.

The grain of oats is composed of two parts, the husk and the kernel. The husk cannot be too thin, nor the kernel too plump. It is found from observation that a fairly definite proportion exists between these two in different qualities of oats.

In poor oats the kernel is 60 per cent. of the weight.

In fairly good oats the kernel is 65 to 70 per cent. of the weight.

In good                    "            "       70 to 75       "       "       "

In very good            "            "       75 to 80       "       "       "

Such are the results of observations made in France,\* where the above system of judging the quality of oats is adopted, rather than weighing a definite bulk of the grain, both husk and kernel, as with us.

This French system has much to recommend it, and will be referred to again.

*Good Oats* should be short, all long oats are thin oats with an excessive amount of husk and a small proportion of flour. The short plump oat is what is looked for.

They should be hard to the pressure of the teeth, showing they have undergone the process of drying, soft oats are either new or damaged.

They must be clean, free from dust, dirt, foreign bodies, and seeds. Perhaps the most common foreign seed is the black seed of vetches, which is bitter to the taste and disliked by horses.

The flour must be sweet and of good colour, discolouration is indicative of change the result of bad preservation, and in mouldy specimens this is very marked.

\* 'Hygiène du Cheval de Guerre.' Chardin.

In inspecting a sample evenness in the size and shape of the grains should be looked for. Plump short oats and thin long oats do not belong to the same crop; they suggest a mixture, which is a very common practice among dealers.

*Old and New Oats.*—It becomes an important matter from a dietetic point of view to determine between old and new oats, and there can be no doubt the question is a difficult one for the layman to decide, but the following may help :

New oats are softer than old, and if of the bearded variety the beards are well preserved. With age these get rubbed off by attrition in the sack. The same remark applies to the pointed ends of the seed which show signs of wear in the old oat while in the new the ends are intact. Fraudulent dealers endeavour to imitate this by clipping the ends of new oats to make them appear old. There is a general appearance of freshness about new oats, with a glazed, almost shiny, exterior which is absent in old oats.

Oats should be kept a year to mature before use. During this time they lose some of their moisture, and an attempt has been made to anticipate this by kiln-drying them. Kiln-dried oats bear a very bad name, but the mere fact of drying oats in a kiln does them no harm. The truth is that in the past attempts have been made to try and save damaged oats by kiln-drying them, and though in this way it is quite possible to stop further chemical change, yet it does not make good oats out of bad.

*Kiln-dried Oats* have been known to give rise to serious urinary trouble. This is not due to the drying, but to the damaged condition of the grain before drying; the sole object of drying is to try and control the chemical change.

Oats in considerable quantities are imported into the kingdom in bulk, and if these are new they all have to be kiln-dried before they can be carried, or else they would heat, but it does them no damage. To condemn oats for being kiln dried is absurd, to condemn them as damaged is quite another thing.

It is mainly on board ship that foreign bodies like nails,

needles, etc., find their way into oats, and they are a very serious source of trouble.

*Bad Oats.*—When oats get damaged from exposure to the weather they become discoloured, they darken and turn brown both the husk and kernel. Depending on the degree of damage they may be merely musty or else sprouting and offensively smelling. If the change is still occurring the grain is quite hot on introducing the hand; if fermentation has ceased through drying, the grain is still irretrievably damaged, has a reddish-brown colour, bitter taste, and musty odour. Such oats are known as *Foxy*.

Various methods are adopted to get rid of the tell-tale colour and odour of damaged oats. A common one is to mix them with good oats, and so endeavour to get rid of them without detection. Another is to fumigate them with sulphur to destroy both the colour and the odour. This fraud can be detected by rubbing the oats in the hand until they are warm, when the characteristic smell of sulphurous acid is produced. Further, the bleaching process cannot convert dark bad flour into good.

*The Weight of Oats.*—It is usual to judge oats by the weight of the bushel. A bushel of good oats will weigh from 40 lbs. to 44 lbs. Inferior oats will weigh as little as 32 lbs.; an average specimen weighs 38 lbs., but such oats are not economical feeding. Authorities on the Continent insist on the method of weighing as being fallacious, and state that the determination which should be made is that of kernel to husk.

For this purpose a sample of the oats is taken, and the husk removed by hand from the kernel, and the two weighed separately. The proportion which kernel bears to husk in various qualities of oats is given on p. 237.

The method of weighing a bushel requires some practice. Nothing should touch the measure, it should be filled at once from a big scoop, and the strike applied. Low class dealers use every device to make the bushel hold more, and this is accomplished by filling it slowly, and giving it a tap with the 'strike' before levelling the top.

By either of these means the bushel is made to hold more corn and thus weigh heavier.

*Methods of Feeding.*—Oats are given whole or bruised, the latter is essential for debilitated horses or those with defective teeth, but for horses in good condition it is unnecessary. Experiments show that no more is digested whether crushed or uncrushed.

The term 'crushing' is an unfortunate one; to really crush corn is wasteful, for the flour separates from the husk, and some horses get more husk others more flour than they should. The term 'bruising' should be used in order to avoid the grain being flattened.

Corn may be given scalded to the sick or debilitated, and in the form of oatmeal is an excellent restorative to the tired hunter, and nourishment to the sick horse.

The amount of oats given daily depends upon the work performed. Hunters and racehorses are unlimited, and will average 16 lbs. a day, though individual horses will eat more. Saddle and carriage horses from 10 lbs. to 13 lbs. or more, according to their size and nature of work. Large draught horses may eat as much as 18 lbs. of corn a day. In all these cases where the work is hard, the corn ration alone is not depended upon, it is always supplemented by beans.

Oats\* vary considerably in their chemical composition depending upon the variety and soil. Here is an analysis by Wolff of an average sample :

Water	...	...	...	...	12·4
Proteids	...	...	...	...	10·4
Carbo-hydrates	...	...	...	...	57·8
Fat	...	...	...	...	5·2
Cellulose	...	...	...	...	11·2
Salts	..	...	...	...	3·0

#### *Maize.*

This grain as a horse food has come largely into favour within the last thirty years, and deservedly so. It experienced, like most innovations, considerable abuse on its

\* For the digestibility of oats see the table on p. 107.



introduction as a disease producer, but in this respect it requires no more than ordinary care, and as an economical force-producing food it is of the greatest value.

In certain countries like South Africa it is the staple forage grain, and in spite of the fact of it being usually given whole, horses and mules do remarkably well on it.

Maize contains nearly as much proteid as oats and more carbo-hydrates, while its fat is equal to oats; in salts, however, it is deficient. Its digestibility is higher than oats, as proved by experiment (see table, p. 107).

As a diet for working horses four or five pounds a day may be given in a mixture, or much larger quantities if given alone.

It must, however, be crushed and mixed with chaff, as it is extremely hard and far too trying for the teeth.

When fed whole, great care should be taken that animals are not watered after feeding owing to the swelling of the grain, which may produce colic or ruptured stomach.

It was generally believed that maize made horses 'soft,' that they sweated easily at work and did not produce the hard condition of oats. There may be some foundation for the latter statement, and one would not from choice train a horse on maize if oats were procurable, but as a good economical food for working horses it can be strongly recommended. Maize should not be given to brood mares or young stock, owing to its deficiency in mineral matter.

As a cattle food it is esteemed, and is excellent for pigs, which rapidly fatten on it.

Maize may be grown in hot dry summers, and given green forms a useful fodder especially for milch cows. It may also be converted into good silage.

ANALYSIS OF MAIZE (WOLFF).

Water	...	...	...	...	12·7
Proteids	...	...	...	...	10·1
Fat	...	...	...	...	4·7
Carbo-hydrates	...	...	...	...	68·6
Cellulose	...	...	...	...	2·3
Salts	...	...	...	...	1·6
					16

*Wheat.*

This is generally recognised as an unsafe food for horses, but probably because they seldom get it owing to its cost. Horses are fond of it, and will gorge themselves if permitted. It should only be given in small quantities, one or two pounds to begin with, and the amount gradually increased. In this way laminitis and abdominal trouble, which are otherwise sure to follow, may be prevented.

Green wheat has been given with marked beneficial effect to horses out of condition, about 10 lbs. daily may be allowed. Wheat in small quantities has been used for sheep feeding with good results. In Voelcker's experiments about 11 ozs. of whole grain were given daily. Wheat can never assume any important proportion as a food for animals; it is in too universal request as a food for man.

There are roughly two envelopes to a grain of wheat, the outside one consists of cellulose, the one inside this is a layer of rich nitrogenous matter termed *cerealine*, and it is to this layer that bran owes such nutritive properties as it possesses. It gives a dark colour to bread, and is considered objectionable on this account. It acts energetically as a ferment, and converts starch into sugar.

These envelopes of wheat furnish *bran*, an important article in the feeding of animals.

*Bran.*

Bran consists of two kinds a fine and coarse, the former is termed *Pollards*, the latter *Bran*. One hundred parts of wheat furnish 80 parts of flour, 16 of bran, and 4 of loss. In chemical composition bran is a most deceptive article of diet, it is rich in proteids—mainly the ferment *cerealine* spoken of above—and a fair proportion of carbo-hydrate and fat; the salts are excessive and are principally represented by magnesium phosphate, which is very insoluble in the

intestinal canal; hence the danger of calculus in bran-fed horses (p. 161).

Bran may be regarded as a good example of a food where analysis and practical experience are at variance. As a food it is useless in spite of its chemical composition; as a useful adjunct it is undeniably valuable, bringing about a general laxative effect on the bowels which is very desirable especially where grain forms a large part of the diet. The laxative effect is believed to be due to the mechanical stimulation of the bran, but the point is by no means settled.

As an article of sick diet it is most valuable, and the practice in all well-regulated stables of giving bran once a week in the form of a mash is attended by the best results.

To produce a laxative effect bran should be mixed with water, in fact, a mash made of it; it is best made with boiling water and covered up until cool enough to eat. In the dry state it is generally believed to have a constipating effect, and it is frequently given dry to horses liable to 'scour,' in order to control this tendency.

It is a good food for milch cows, and is found to improve the quality of the milk and butter.

Bran should have a pleasant odour, a yellowish tint, and be free from dust and dirt. When rubbed between the hands it should slightly whiten them from the flour it contains. It may be adulterated with sand or sawdust; the best test for the former is to put it in water, when the sand falls to the bottom.

Bran only keeps sweet a short time, it rapidly absorbs moisture, turns sour, becomes caked in masses, and quite unfit for food.

The daily amount of bran given may be 2 lbs. more or less depending on the work, but bearing in mind that it possesses no nutritive properties, the interior should not be burdened with it unnecessarily.

Large mashes of bran are liable to give rise to colic, and even ruptured stomach, from the fermentation which occurs

during its digestion. A mash ought not to exceed  $3\frac{1}{2}$  lbs. of bran.

ANALYSIS OF BRAN (WOLFF).

Water	...	...	...	...	13.6
Proteids	...	...	...	...	13.6
Fat	...	...	...	...	3.4
Carbo-hydrates	...	...	...	...	54.9
Cellulose	...	...	...	...	8.9
Salts	...	...	...	...	5.6

*Rye.*

This is seldom used as a food excepting on the Continent of Europe.

It is a grain suited to poor soils, and in some parts of England it is sown as a catch-crop to provide spring keep for sheep. It is also said to be a good soiling food for horses.

The grain is very liable to the attack of a fungus (p. 165).

*Rice.*

In the East this is sometimes used in the feeding of horses, especially for supplying the needful carbo-hydrate where highly nitrogenous grains are being given.

It is a grain poor in nitrogen, almost deficient in fat, but contains an abundance of starch. If employed as a feeding grain for horses it should be given crushed.

*Millets.*

These represent a group of cereals, largely but not exclusively used by people in the East. They contain a fair proportion of proteid, a large amount of starch, and but little salts or fat.

The parts most used as food for animals are the green stalks with the young flowering heads, and the straw after threshing. The Belooch mares in the Punjab receive scarcely any other grain than millet, and are capable of extraordinary exertion.

The stalks may be given chaffed; the straw is very nutritious, and oxen in India are capable of performing very hard work on it.

### *Barley.*

Barley is very largely grown, but for malting purposes rather than as a food supply. In the East it becomes the staple feeding grain for horses, and takes the place of oats.

The crop should only be cut when it is fully ripe; it is a most difficult one to deal with, and requires the greatest care, not, however, from a feeding but from a malting point of view. The barley used for feeding is frequently that which is unfit for the purposes of the maltster.

Barley does not contain as much nitrogen as oats, but more carbo-hydrates and less fat. The grain is excessively hard, which is probably one reason why its use for horses is not popular; it requires crushing or in some way preparing for food. In India it is frequently parched, it is sometimes given after soaking in water, or it may be boiled or malted; it is also often given without any preparation whatever. In such cases a large amount passes away with the fæces, having escaped digestion.

Barley should have a thin wrinkled skin closely adherent to the kernel, the grain plump with short fine ends, and the bushel should weigh from 53 lbs. to 58 lbs.

Experience shows it is a good food for horses, but it is not in many cases a convenient one. As part of a mixture, and given crushed, it is quite unobjectionable, and if it is cheaper than oats it becomes economical.

The awns on barley, particularly of the common varieties, have been considered to be productive of intestinal irritation. Other trouble such as laminitis has been attributed to this grain, but when this occurs it is generally due to want of care in feeding.

As a food for cattle and sheep it is frequently given boiled as part of a mixture, or ground in the form of meal.

This latter forms the essential diet of fattening pigs, which of all animals fully utilize and do well on it; for every five pounds of barley meal given to pigs as food, they store up one pound as body weight.

*Malted Barley.*—Barley is sometimes given malted, viz. the grains are moistened, spread out and allowed to germinate. As the result of this the seed grows an elementary stem and root, and when the former is about two-thirds the length of the grain, further germination is stopped by drying in a kiln. As the result of the drying the elementary stem and root—now known as *malt-dust* or *combings*—fall off the grain, and are removed by screening.

The grain itself as the result of fermentation has undergone chemical change, part of the starch being converted into sugar; in addition to this there is a considerable loss of substance, and it is very doubtful whether malting is not a wasteful process for food purposes. For the sick and debilitated it is useful, and saves the digestive fluids a certain amount of work; it is also a good food in the rearing of young animals and for milch cows; with the latter care should be taken in its use as excessive quantities have been said to produce abortion, and that the amount given daily should not on this account exceed four to six pounds.

Malt-dust is very rich in nitrogen and salts, it contains nearly as much nitrogen as beans, but much of it is in the form of amides.

*Brewers' Grains* are the refuse in one of the operations of beer-making. They are largely valued as a food for fattening cattle, but especially for milch cows. They contain a large proportion of water, and on this account are liable to undergo decomposition; sometimes for convenience of transport they are dried.

The amount of grains given daily is about one to one and a half bushels. It is said by some experienced dairy stock keepers that the continued use of grains ruins a cow's constitution.

*Distillers' Grains* are frequently mixed with rye, and by some are considered better for cows than brewers' grains; both increase the bulk but not the quality of the milk.

Grains are very liable to fermentation, they are generally acid when obtained; distillers' grains in this respect are worse than brewers'. It may be this constant acidity which in course of time destroys the cow's digestion. It is quite certain that grains are productive of stomach trouble, tympany, and so forth, and to avoid this should be mixed with straw chaff.

*Distillers' Wash* is a malt refuse after distillation, it was formerly used exclusively for swine, but it has been shown that fattening cattle do very well on it with an ordinary hay and straw diet.

The following is the composition of barley and its products:

	Barley.	Malt.	Malt Sprouts.	Brewers' Grains.
Water ... ..	14.0	7.5	11.8	76.1
Proteids ... ..	10.0	9.4	23.3	5.3
Carbo-hydrates ...	66.1	69.8	42.8	12.9
Fat ... ..	2.3	2.3	2.1	1.5
Cellulose ... ..	4.9	8.7	12.4	3.9
Salts... ..	2.7	2.3	7.6	1.1

The following is their digestibility:

	Organic Matter.	Proteids.	Cellulose.	Fat.	Carbo-hydrates.
Barley:					
Horse ... ..	87	80	100	42	87
Ruminants ... ..	86	70	50	89	92
Brewers' Grains:					
Ruminants ... ..	65	72	42	84	67
Malt Sprouts:					
Ruminants ... ..	81	78	85	50	86

## THE PULSES.

These belong to the Natural Order *Leguminosæ*, and those used for feeding purposes may be classified as peas or beans.

Their chief value as food depends upon the considerable amount of proteid they contain, and they are therefore of the greatest value for horses as an addition to the ordinary diet, where severe work has to be accomplished. They are quite unsuited by themselves for feeding purposes, though in some parts of the world, as in India and China, they have from necessity to be largely used.

Speaking generally it may be said they are intensely stimulating, far too rich for ordinary use, very indigestible and gas producing, and require great care in administration.

*Peas.*

There are many varieties of peas, but the one used for animal food is the grey pea, *Pisum arvense*. The stem or haulm of peas makes a very good fodder especially for cattle and sheep. As a straw it is one of the richest, but it is difficult to save properly, being liable to mildew. It should be given chaffed or steamed, and is said to produce an excellent coloured butter.

The grain itself is not so digestible as beans, and the latter are always preferred for horses. For pigs and cattle pea meal may be given with advantage, either ground or split. It is a good food for fattening animals and increases the flow of milk.

Peas should be one year old before being used, they should be free from weevil, sound, sweet, and weigh 64 lbs. to the bushel.

The amount given daily depends upon the purpose for which they are intended, from one-half to two pounds may be given to fattening cattle depending upon the other food, and the same holds good for horses. They should always be split or ground.



*Gram (Cicer arietinum).*

This is the staple grain used for horse feeding in Northern India. It is a pea, highly nitrogenous, of a reddish-brown and yellow colour, wrinkled externally, and excessively hard. The grain should be at least six months old before using, and free from weevil with which it is very commonly infected.

It may be given crushed, or the whole grain soaked for some hours; the former is most commonly adopted. The crushed grain should not be soaked as it rapidly turns sour.

This grain is given in quantities of ten pounds daily; it means, of course, that the diet is very badly balanced, being excessively nitrogenous and often producing serious trouble from the difficulty in its digestion. It produces also extreme fœtor of the dejecta, and a very high-coloured urine, frequently the tint of coffee. These are indications of excess, and if not attended to the liver may participate and further disorder arise.

Gram and barley make a good feeding mixture during the cold weather in India. During the summer, barley and rice with little or no gram, would prove a sufficient diet, as the horses do no work.

## ANALYSIS OF PEAS.

	Peas.	Gram.
Water ... ..	14.4	10.80
Proteids ... ..	22.6	19.32
Fat ... ..	1.9	4.56
Carbo-hydrates ... ..	53.0	62.20
Cellulose ... ..	5.4	
Salts ... ..	2.7	3.12

## TABLE OF DIGESTIBILITY OF PEAS.

	Organic Matter.	Proteids.	Cellulose.	Fat.	Carbo-hydrates.
Horse ... ..	80	83	8	9	89
Ruminant ... ..	90	89	66	75	93

*Beans.*

These consist of many varieties, of which the one known as the horse bean, *Faba vulgaris*, is employed for the feeding of animals. Even of this there are several kinds, the chief being the *tick* and *negro*. The straw of beans is not considered so good for feeding purposes as that of pea, though it may be cut and mixed with the latter.

The plant is very liable to fly attack, *bean aphis*, and to rust and mildew.

Beans should be one year old before being used, they should be short and plump, free from weevil, and weigh about 63 lbs. to the bushel.

The amount given daily to horses doing severe work is from 1 lb. to 2 lbs. crushed and mixed with the ordinary ration.

As meal it is largely used in the feeding of cattle, sheep and pigs with the best results.

There are certain beans used in India for feeding purposes. They are all remarkable for the amount of proteid they contain, and one known as *Bhoot*, *Soja hispida*, for the extraordinary amount of both proteid and fat. It corresponds to the Chinese bean known as *Salmca*.

*Cooltee*, *Dolichos uniflorus*, is the chief feeding grain of Southern India; it is a small grey or brown bean which turns nearly black on boiling. As a rule the grain is mixed with a quantity of sand and gravel, and the loss of horses from this cause would pay over and over again for the needful machinery for cleaning it.

The amount given of these grains is generally 10 lbs. daily. They all have to be boiled, and are fruitful sources of disease both from their liability to ferment, their badly balanced constituents, and their mode of preparation.

The following table gives an analysis of beans, and some

of the principal Indian feeding pulses, with their native names.\*

	Beans.	Bhoot.	Oorud.	Moong.	Mote.	Cooltee.
Water ... ..	14.4	8.12	11.0	9.20	11.22	11.30
Proteids ... ..	25.0	40.63	22.48	24.70	23.80	23.47
Fat ... ..	1.6	17.71	1.46	1.48	0.64	0.87
Carbo-hydrates ... ..	55.8	29.54	62.15	60.36	60.78	61.02
Salts ... ..	3.2	4.00	2.91	3.26	3.56	3.34

### OLEAGINOUS SEEDS.

This important class of food-stuff, represented by Linseed, Cotton, Rape, and other seeds, is very largely used in cattle feeding owing to the amount of fat it contains.

The discovery of cake was an accidental circumstance ; the refuse after expression of the oil was at first thrown away, the farmer now willingly pays from £6 to £9 a ton for it. Owing to its high price and the heavy demand, the temptation to cheat the purchaser by adulteration has apparently been irresistible, for the fact remains there is nothing in the feeding line in which he requires greater protection, and nothing in which he is more openly robbed. About half a million tons of linseed cake alone are consumed in Great Britain yearly, which conveys an idea of the extent of this industry, and the facilities which exist for palming off worthless material.

As the matter of feeding cakes is an important one, no apology is necessary for dealing with it in some little detail, but it is desirable in the first place to consider linseed in its condition as a grain.

#### *Linseed.*

Linseed is derived from the flax plant, the stem of which furnishes the fibre from which linen is made, while the seeds of the capsule supply oil and feeding cake.

Linseed is highly nitrogenous and fatty, and contains a

\* For the digestibility of beans see table, p. 107.

good proportion of salts, but the carbo-hydrate matter is small and represented entirely by mucilage and sugar. Given without any preparation it passes undigested through the intestinal canal, owing to the hardness of the seeds. It is best prepared by prolonged boiling by which a glutinous or jelly-like mass is obtained. It may also be converted into the same condition by long soaking in cold water, say two or three days. Another method is to cover the seeds with boiling water and allow them to stand until cool, this does not remove the oil but simply swells and softens the grains.

Some farmers prefer to give linseed, treated as above, to their fattening stock instead of cake. It has the great advantage of knowing they are getting linseed and not some inferior material.

As a diet for sick animals it is very valuable on account of its nutritious properties. For horses out of condition it is a useful addition to the diet in small quantities, certainly not exceeding 1 lb. a day. It is believed to have a good effect upon the skin and coat, and in order to produce the latter and also to help debilitated horses, small quantities of the oil are frequently given. Experience seems to show that this practice is nothing like so valuable as the administration of linseed, so that it would appear much of the value of the latter is due to the proteid as well as to the oil.

Linseed yields the following analysis :

Water	...	...	...	...	12.3
Proteids	...	...	...	...	20.5
Fat	...	...	...	...	37.0
Carbo-hydrates	...	...	...	...	19.6
Cellulose	...	...	...	...	7.2
Salts	...	...	...	...	3.4

According to digestive experiments 75 per cent. of the proteids, 52 per cent. of the fat, and 98 per cent. of the carbo-hydrates are digested by the horse. The digestion of ruminants is better, 90 per cent. of the fat being absorbed.

When linseed is pressed in a mill the oil, or a good deal of it, is squeezed out, and the resulting substance is known as linseed cake.

### *Oil Cakes.*

The chief of these is linseed the manufacture of which has just been mentioned, it contains a variable amount of oil depending upon the pressure which has been applied, but with the most perfect pressure the amount left behind varies from 10 per cent. to 15 per cent.

The pressure has in no way interfered with the proteid or carbo-hydrate substances, these are left behind the resulting mass being a highly concentrated food. This remark applies to all seeds from which other cakes are made, viz. cotton, rape, etc.

Linseed cake owing to the demand is frequently adulterated, pure linseed is what is expected in the best cakes, but unscrupulous manufacturers introduce other oil seeds obtainable at a very much cheaper rate, and sell the cake at linseed prices.

So strong is the temptation to adulterate linseed that on the authority of Letheby, it is stated that the siftings of linseed are not thrown away but are used for adulterating other samples, even to the extent of being sent out to sea in barges to meet vessels coming in, mixed at sea, and sold on arrival as genuine linseed 'as imported.'

Foreign made cakes are frequently impure and unsound; the only exceptions are the American cakes which are pure but hard and present a low percentage of oil, and some of the cakes made in the north of Germany.

There are certain seeds like castor, croton, and mustard, capable of yielding oil on compression, but the residue is unfit for food being poisonous, though mustard seed is frequently used as an adulterant of some cakes.

*Rape* yields a cake which frequently contains mustard, not necessarily as an adulteration, but because under careless agriculture the two are grown together. Its presence renders rape cake very often unsafe, and never reliable

unless submitted to a process which will be mentioned presently. Cattle at first do not take to rape cake, but eat it freely after a time.

*Cotton seed* yields an excellent cake, it is manufactured either after the husks of the seed have been removed, and known then as decorticated cake, or with the husks still present as undecorticated. Very great difference of opinion exists as to the relative value of the two cakes, but the consensus of opinion points to the decorticated variety as being the best and safest; further, it contains much less cellulose, for the husks in the undecorticated cake give over 20 per cent. of cellulose as against 9 per cent. in the decorticated cake.

By some, cotton cake is considered too astringent for calves, and in all cases the undecorticated variety is liable to induce stomach or intestinal trouble owing to the husks.

Dr. J. A. Voelcker, whose official position in the Royal Agricultural Society has afforded him an extensive acquaintance with feeding cakes, says\* that the nice soft decorticated cotton cake of eleven years ago is now a thing of the past, and its place taken by decorticated cake made from Bombay cotton seeds. This cake is less nitrogenous and more sandy than the original cake. The undecorticated cake of the present day is made from Bombay instead of Egyptian seed, and is very 'woolly,' besides containing sand and borax, the latter being added as a preservative.

Though the best cotton seed for cakes is spoken of as Egyptian, it is not of Egyptian origin but is one of the American varieties, distinguished by the staple of the wool, and the readiness with which the cotton can be separated from the seed. With the Bombay cotton seed the wool lies closely matted on the husk, and cannot be removed by the process of 'ginning.' The woolly Bombay cakes Voelcker considers are liable to cause bowel obstruction, from the manner in which they collect portions of husk and form masses.†

\* *Journal Royal Agricultural Society*, vol. lxiv., 1903.

† *Op. cit.*

*Compound or Mixed Cakes* are extensively used on account of their cheapness. Each manufacturer uses his own recipe, a variety of material good and worthless being employed in their production.

There are other seeds used in the manufacture of cake, viz. ground-nut, palmkernel, poppy, hemp, cocoanut, sesame or 'til,' but none of these are in such favour as linseed.

The following table gives the composition of several cakes :

	Pure Linseed Cake (Voelcker).	Linseed Cake.	Cotton Cake, Undecorti- cated.	Cotton Cake, Decorticated.	Rape Cake.	Palm-nut Cake.	Ground-nut Cake.	'Til' Cake.
Water ...	10·29	11·8	10·6	8·9	10·4	10·2	9·8	11·1
Proteids ...	28·59	28·7	24·7	43·6	30·7	16·1	31·0	37·2
Fat ...	12·66	10·7	6·6	14·9	9·8	9·5	8·9	12·8
Carbo- hydrates	34·85	32·1	26·0	19·7	30·1	41·9	20·7	20·5
Cellulose...	8·07	9·4	24·9	5·7	11·3	18·3	22·7	7·5
Salts ..	5·54	7·3	7·2	7·2	7·7	4·0	6·9	10·9

All but the first analysis is by Wolff. It will be observed that the largest amount of oil is contained in linseed, decorticated cotton, and 'til' cakes.

#### *Adulteration of Cakes.*

The cake which mainly suffers adulteration is linseed. A good linseed cake should not be too pale in colour, and must be hard and difficult to break. A soft easily broken cake is sure to be adulterated, and even a hard cake if pale must be regarded with suspicion. Good linseed cake has a sweet mucilaginous taste; a turnipy or acrid taste indicates impurities, the most common being a mixture of rape and mustard seeds.

All the seeds mentioned above may find their way as adulterants of linseed cake, they are employed on account of their cheapness, and Voelcker has shown that rape and

linseed mixed in varying proportions, can be so arranged by the manufacturers as to defy chemical though not microscopical analysis.

Besides these, cakes are adulterated with husks of oats, barley, rice, cocoanut fibre, bran—even the waste bran from tinplate works—and such poisonous seeds as castor and purging flax. Castor oil bean is found in foreign-made linseed cake, especially that which comes from Marseilles. At the latter part a good deal of castor bean is crushed, and the same mill used for linseed, care not being taken to clean the mill out before putting the linseed in.\*

A manufacturer stated in a court of law that his ordinary oil cake consisted of 50 parts of 'til' or sesame cake, 20 parts of bran, and 30 of linseed and linseed sifting. It is to be observed that in such cases the cake is not described as linseed cake but as oil cake, which though technically correct is intended as a deception, and purchased by the unwary as linseed cake.

Another inducement to adulteration is the ready sale found for cheap cakes, though the farmer ought to know that no linseed cake if pure can be produced and sold under a given price per ton.

The manufacturer of spurious cakes grinds his material very fine in what is known as a 'Buffein Machine,' the object of this is to increase the difficulties of a naked eye and microscopical analysis.

Some years ago the late Dr. Voelcker† gave directions for a rough examination of feeding cakes, the substance of which is here given.

In examining a cake reduce it to powder by grating, take half an ounce of the powder and mix it with five ounces of water, and if the cake is good it produces a transparent stiff jelly of agreeable smell and taste. There are some seeds which give a very unpleasant odour to the mass.

\* Dr. J. A. Voelcker, *Journal Royal Agricultural Society*, vol. v., part iv., 1894.

† 'Pure and Mixed Linseed Cakes': *Journal Royal Agricultural Society of England*, vol. ix., part i., 2nd series.



If water be added to a paste formed of the grated cake, it is possible to detect the bran and sand, the former floats, the latter sinks. It is stated that the determination of the amount of sand is valuable, as a definite figure may be assigned to it; in pure cakes it should not exceed 2 per cent., or even less, if the seed has been properly screened.

There is no starch in linseed cake, but when rice, oats, and other cereals are added, the starch may be extracted by the above process, and readily tested for with iodine.

The examination of rape cake is principally made for mustard, but this should also be looked for in linseed cake. Voelcker recommends half an ounce of the grated cake being mixed with six ounces of water, placed in a stoppered bottle kept in a warm room, and examined after twenty-four hours; even when rape cake contains a considerable amount of mustard, no smell of the same is developed for some time. The explanation of this is that mustard seed does not contain mustard as we recognise it, but possesses two substances, which produce mustard, one is a ferment known as 'myron,' which acts upon the second body 'myronic acid' under the influence of moisture, and produces oil of mustard.

If mustard seeds be treated with boiling water the ferment is destroyed, and no mustard oil formed. So marked is this that even pure mustard cake may be rendered harmless in this way.

The practical application of this fact is evident, rape cake can be safely employed when steamed or treated with boiling water after being reduced to a coarse powder, and under this process not only loses its acrid qualities, but acquires a smell and taste which induce cattle to eat it readily. As rape is half the price of linseed cake the value of this method is evident.

Voelcker\* urges that a linseed cake guarantee should make no reference to the usual 95 per cent. pure seed, as it leaves out of account the remaining 5 per cent. which may be poisonous. Further he says the cake must be sold as

\* *Journal Royal Agricultural Society*, vol. lxiii., 1892.

'pure linseed cake,' and that any cake not pure must be sold simply as 'oil cake.' The same authority\* describes a new method of adulterating decorticated cotton cake, viz., by removing the husk, which is then finely ground up and put back again into the meal, the cake being sold as decorticated.

The adulteration is difficult to detect; the meal should be washed in water, and the husk left behind is much finer in size, regular, and more angular in shape, than the husk of genuine decorticated cake which has accidentally missed removal.

For the microscopical examination of cakes the examiner if not familiar with the appearance of the various starches, husks, grains, seeds, etc., should prepare specimens of the same, and use them for comparison with the cakes under inspection.

*Diseases produced by Cake.*—All cakes should be in good condition, sound, fresh, free from smell and mouldiness. Sourness and mouldiness are often the results of the cake not being thoroughly dried before being stored, in consequence of which it heats. Sourness may also be caused by the use of seeds which have become rancid, and in either case such cake is unfit for food.

The husks of undecorticated cotton cake were such a source of stomach and intestinal trouble, that methods had to be adopted to get rid of them; it was this led to the creation of the decorticated cake which possesses so many advantages.

Stomach and intestinal irritation may also be caused by the woolly masses and stiff hairs found in impure specimens of ground-nut cake, and in Bombay undecorticated cotton cake. The poisonous properties of beech-nut cake when given to horses has previously been alluded to (p. 193).

Within recent years cake as a carrier of infection has been more than suspected. Anthrax has been traced to this source, the germs of the disease having contaminated the linseed before manufacture. Such contamination is

\* *Journal Royal Agricultural Society*, vol. lxiii., 1901.

quite easy in a disease like anthrax, if the same ship has been previously employed carrying infected hides.

Manufacturers of cakes would do well to expose all foreign seeds to a sufficiently high temperature, in the preparatory process for cake manufacture, to ensure the destruction of any possible pathogenic organism.

*Digestibility of Cakes.*—The following table exhibits the digestibility of the various cakes :

	Total Organic Matter.	Proteids.	Cellulose.	Fat.	Carbo-hydrates.
Linseed Cake :					
Horse ... ..	69	88	—	53	94
Ruminants ...	81	86	44	90	80
Rape Cake :					
Ruminants ...	66	81	8	79	76
Cotton Cake (unde-corticated) :					
Ruminants ...	56	75	12	89	54
Cotton Cake (decor-ticated) :					
Ruminants ...	80	85	—	88	95
'Til' Cake :					
Ruminants ...	77	90	31	90	63
Palm-nut Cake .					
Ruminants ...	75	77	54	94	79
Ground-nut Cake:					
Ruminants ...	85	91	16	86	98

The amount of cake given to animals depends upon the object in view ; dairy cows may receive as much as 4 lbs. a day if their ordinary diet is inferior, with good feeding 2 lbs. is sufficient. Sheep should receive from  $\frac{1}{2}$  to 1 lb. ; fattening oxen, 4 lbs. to 6 lbs. daily.

#### ROOTS.

A very important article of cattle and sheep feeding in the winter is derived from the 'root crop' ; these include mangel-wurzel, swedes, turnips, kohl-rabi, cabbage, potatoes, and carrots.

It is by means of 'roots' that the farmer is enabled to

provide his animals with the needful fresh vegetable material until the spring with its young grass arrives. These roots are derived from different Natural Orders, and experience has confirmed their value for all classes of cattle and sheep.

Chemically all 'roots' are very much alike. They contain a quantity of water, a variable quantity of nitrogen of which only about half is albuminous, the other portion being amides. They contain a nitrogen free substance known as *pectin* which is capable of conversion into sugar, but no starch, excepting a little found in parsnips and carrots. Of sugar there is a variable quantity, which in the beet, a root closely allied to the mangel, reaches its fullest degree.

The pectin is very digestible, it is said 98 per cent. is digested by sheep, and pectin in the system may be considered as equivalent to starch or sugar.

Looked at in this light, 'roots' are regarded from a feeding point of view as practically consisting of water and carbo-hydrates, and it is these two points which have to be borne in mind in using them as food substances. Excessive amounts of roots with a diet poor in nitrogen exercise a depressing effect on digestion, just as if so much starch had been given; further, excessive amounts cause the diet to be watery. All attempts to bring up animals such as store cattle and sheep on roots and little else during the winter fail; it is by no means economical feeding, for the animals lose ground, and to get the needful amount of nourishment require to consume an immense amount of this poor watery diet. From this cause cattle have been known to consume as much as 220 lbs. of turnips daily, resulting in habitual diarrhœa.

Roots are most valuable, but only as an adjunct to the diet; they cannot replace good feeding, and it is the height of folly to give them in excess.

The roots generally employed are swedes, mangels, and turnips, the latter is principally used in Scotland, the former in England.

It is generally believed that sheep are somewhat difficult to bring on to roots owing to the liability to 'scour,' but it is quite possible this may be due to the fact they have been given in excess. Sheep should be brought on to them in sparing quantities, and with a sufficiently nitrogenous diet. Most sheep breeders restrict their in-lamb ewes in the matter of roots, owing to the supposed liability to abortion.

*Mangels* are a very valuable crop, but better suited for spring and early summer feeding than for autumn and winter. This is due to the fact they require at least two months to mature after the crop is 'pulled,' during which time sugar develops at the expense of the pectin, and the irritating properties of the mangel, which cause diarrhoea, are got rid of. It is said by some that if mangels are exposed to the air for a week or two, they may be used early in the season with safety. If mangels are kept too long they lose a considerable amount of dry matter, due to destruction of the sugar.

Mangels are very liable to be damaged by frost, so during the winter they should be buried. Frost-bitten roots frequently cause tympany and other trouble.

Mangels in excess are liable with male sheep to produce serious trouble. McFadyean has shown\* that a diet of mangels produces diuresis, increases the alkalinity of the urine, and so favours the deposition of salts of magnesium phosphate, the crystals of which, being unable to pass through the vermiform appendix of the penis, block the urethra.

The mangel crop is not very prone to parasitic trouble excepting from the attacks of the Beet Fly, which blisters the leaf by feeding on its structure.

Mangels should be given sliced or pulped; the bulk of evidence is in favour of slicing, as they then require more mastication and animals do better on them.

The amount allowed to animals is from 60 lbs. to 70 lbs. daily for cattle, and about 20 lbs. or less for sheep.

\* *Journal Royal Agricultural Society*, vol. ix., part i., 1898.

*Turnips and Swedes.*—These may conveniently be considered together as they belong to the same family. The swede is distinguished from the turnip by the neck or collar it possesses, and is of two kinds the green and purple top. They should not be used for feeding purposes until they are ripe. As they mature before mangels they should be used before them for early winter feeding.

There are many varieties of turnip, the names of which it is unnecessary to mention. They afford most excellent feeding material, and are used in the North and in Scotland to the exclusion of mangel, which does not do well there owing to the short season.

Turnips give butter a bad taste, and many devices have been adopted to prevent the milk getting infected, such as cutting off the crown of the turnip and feeding on the lower portion; steaming the root before administration; putting a little nitre in the milk-pail before milking, or even by giving furze to the cows, which is said to correct the taste given by turnips. Perhaps the most common preventive is to give the turnips after milking.

Turnips possess an aperient effect which may be beneficial; if excessive this is corrected by reducing the amount and giving a little more hay.

Turnips during their growth are very liable to be attacked by a fungus which produces a distorted condition of the root, to which the name 'fingers and toes' has been given.

Swedes and turnips for cattle must be sliced or pulped and mixed with the hay and meal. From 60 lbs. to 70 lbs. are given to cattle, 16 lbs. to 20 lbs. daily to sheep.

Turnips to the extent of over 200 lbs. daily have been given to cattle with a poor nitrogenous diet, viz., straw, but such feeding, though common in Scotland during the winter, is not to be recommended, when it is borne in mind that there is more water in turnips than in milk.

Sheep generally get their turnips by grazing and gnawing the root crop in the field, the animals are folded on the land, and while they are feeding they are manuring and

treading down the soil. If roots are pulled and given to sheep they should be sliced.

Feeding off 'root crops' with sheep and folding the animals on the land is an important part of husbandry, for in this way the land is prepared for the cereal crop which in rotation follows roots.

Turnips, swedes, and kohl-rabi constitute the main winter keep of sheep. Sometimes mangel leaves and turnip tops are used as green food, but they are very liable to scour and should be limited in quantity.

*Rape* is a plant closely allied to the turnip and swede. It is cultivated for the leaves and not for the root. There are two varieties, dwarf and giant. It produces an early green crop, and is essentially used for sheep.

*Cabbage* and *Kohl-rabi* belong to the same family. They are good feeding for sheep prior to the use of swedes. Cabbage is also given to cattle, being greatly appreciated by milch-cows, but it imparts a taste to the butter unless all decayed leaves are removed; it should be sliced and mixed with the hay.

As winter feeding for store stock the above may be given with pea or oat straw, or with hay to fattening stock. Kohl-rabi gives an excellent taste to milk and butter, though there are some who do not like it as a food.

Another member of the cabbage family is the *Thousand-headed Kale*, which is useful in backward seasons for sheep, between 'roots' and grass.

*Carrots and parsnips* are used as succulent fodder, the former particularly for horses though cattle are equally fond of them.

Carrots are most beneficial for sick and debilitated horses; they are slightly diuretic and laxative. They induce appetite when mixed with the ordinary food, and are an article of the greatest value in the hospital. There is no food of which the horse is so inordinately fond, he will even try when dying to find the needful effort to masticate them. Carrots form an excellent change in diet for horses, and should always be given if obtainable.

Parsnips are said to be good feeding for both store and fattening cattle, in fact some have considered them equal to oil cake, but the palate soon tires of them.

*Potatoes* are frequently used for feeding, either cooked or simply cut. In the raw state they produce purging, and in the horse colic, while it is even said enteritis may be caused, but this can only occur in the event of some poisonous substance being formed in potatoes which have been damaged. Cooking no doubt destroys the indigestible properties of potatoes, but excepting for slow worked farm horses they are not recommended as a diet. Cooking has no influence in destroying the poison formed in damaged potatoes (see p. 194).

Even with cattle the effects of potatoes have to be watched as they are liable to disagree. Cattle may receive one or two bushels of steamed potatoes daily mixed with their hay.

The following table from Wolff gives the chemical composition of the various 'roots':

	Mangels.	Swedes.	T. rsnips.	Kohl-rabi.	Potatoes.	Carrots.
Water ...	88·0	87·0	92·0	88·2	75·0	85·0
Proteids ...	1·1	1·3	1·1	2·3	2·1	1·4
Fat ...	0·1	0·1	0·1	0·1	0·2	0·2
Carbo- hydrates	9·1	9·5	5·3	6·9	20·7	10·8
Cellulose ...	0·9	1·1	0·8	1·5	1·1	1·7
Salts ...	0·8	1·0	0·7	1·0	0·9	0·9

#### PREPARATION OF FOOD.

##### *Chaff.*

The use of chaff has more than once been alluded to in these pages, especially its economical value. It is no exaggeration to say that large commercial firms in the United Kingdom must save many thousands of pounds annually by its use, and their horses are better and more rationally fed.



Its strong point is the saving of waste, such as must occur with long hay, the use of which it is safe to say, even with care, causes a loss of one quarter of the day's ration. Long hay gets pulled about by the horse, mixed with the bedding, trampled underfoot, and soiled by the excreta.

All this is prevented by the use of chaff; better mastication of the corn ration is also assured, as the two are mixed together, though in varying proportions depending on the nature of the work performed.

Chaff may consist of meadow or clover hay, or good straw; for the heavier breeds of horses hay and straw are frequently employed, for lighter horses hay alone, though this may be the result of prejudice, as good oat straw is superior to indifferent hay.

The length chaff is cut is a matter often debated; for working horses where the nosebag is put on at every opportunity, the shorter chaff is cut within reason the better, as time is saved to the animal.

On the score of saving labour to horses that lead a comparatively idle life chaff is not recommended, as they have enough time before them for the mastication of long hay, but as a source of economy to the owner's pocket it is advised.

Chaff when mixed with corn should be damped if possible, as it prevents the grain separating from the chaff.

There are many forms of chaff-cutter in use, and the pattern selected must depend upon the number of horses for which chaff has to be provided. It is very hard work to cut it by hand, and in consequence the machine is constantly 'in need of repair'; when driven by power, this difficulty does not so frequently arise. Machines may now be had, capable of cutting 3 tons of chaff per hour.

It is not economy to buy chaff, as so much worthless material is cut up and is then somewhat difficult of identification.

#### *Bruised and Crushed Grain.*

The common term for this is 'crushed' grain, but we have previously pointed out that the crushing of oats for

horses is most undesirable, though for cattle beans, peas, barley, and maize, may be reduced to the condition of meal.

The reason why oats should only be bruised and not flattened, is to save loss of flour which inevitably follows crushing, so that some of the animals get an undue proportion of husk and others an excess of flour.

It should be borne in mind bruised grain does not keep sweet long, and that it should only be prepared in the amounts required.

The advantages and disadvantages of bruising have been previously referred to, but they may be repeated here. Bruised oats save a weak digestion, or a horse with defective teeth, or one sick and debilitated. It does not cause a larger amount of food to become digested, and is unnecessary for animals in health.

The bruising or even crushing of beans, peas, linseed, or maize, is absolutely essential for all animals, on account of the hardness of the envelope.

#### *Cleaning Grain.*

Only those who have a practical acquaintance with colic in the horse, can form an idea how frequently intestinal trouble can be attributed to dirt, gravel, and foreign bodies swallowed with the food, all of which can be separated by machinery. Sometimes the dirt is obtained in the threshing, as is the gravel found with 'cooltie,' occasionally it is to be feared it is added intentionally to make weight, or it may be swept up with the grain; foreign bodies like nails, wire, etc., generally find their way in during transport in bulk, as on board ship.

Cleanliness should be looked for in all corn; with a dirty sample a little patience enables an analysis to be made, by taking a known weight and separating the grain from the dirt by hand.

All large grain contracts should specify the question of cleanliness by screening, and freedom from foreign bodies. These latter, if metal, are separated by passing the grain over electro-magnets, and this practice is regularly em-

ployed by some of the large horse feeding companies in the Kingdom.

Among army horses that have to live so frequently in the open, the amount of dirt taken into the stomach with the food is often considerable. It is not entirely preventable, and is due to having to take their hay off the ground.

*The cleansing of roots* is an important point to attend to with cattle, they can be scraped and brushed which effectually removes dry earth, or they may be washed.

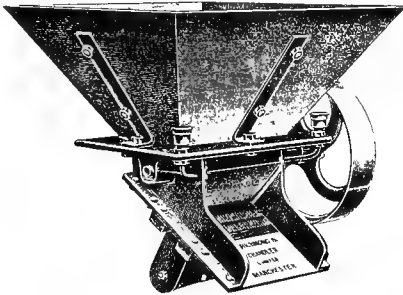

Fig. 77.—Corn feed regulator and magnetic apparatus, for removing wire, nails, screws, pins, etc., from grain, by passing it over a magnetic surface. In the above arrangement of Messrs. Richmond and Chandler, of Manchester, the grain travels down an inclined metal face, in which there is a magnetic line of great power, indicated by the chequered pattern in the illustration. The magnetic surface can be had in widths varying from 6 inches to 24 inches.

### *Root Slicers and Pulpers.*

The farmer who studies economy always slices or pulps his roots. Feeding on whole roots is a prolific source of impaction of the œsophagus, and this can entirely be prevented by slicing, for which there are many appliances.

There is a great difference of opinion regarding the value of pulping roots; many contend that the suppression of rumination this causes is undesirable, there are others who urge pulping on the score of economy.

Perhaps for very young animals being brought on to roots for the first time, and with teeth not too strong, pulping may be recommended, but for adult animals slicing should be sufficient.

*Cake Breakers.*

Some cakes, especially good ones, are as hard as beans, they must be broken to save waste and economise the animal's teeth. For young animals they should even be reduced to a coarse powder.

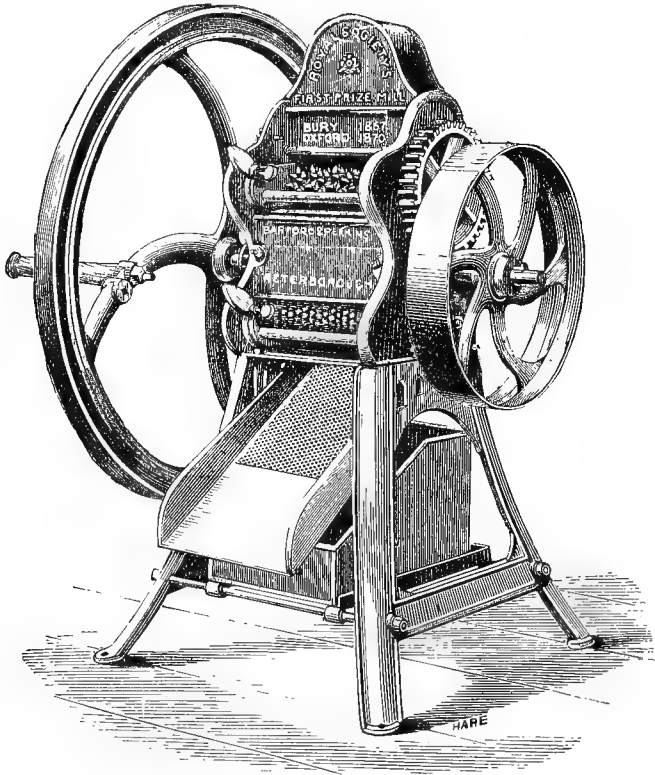

Fig. 78.—Oil Cake Breaker (Barford and Perkins).

*Maceration.*

Grains like maize, 'gram' linseed, etc. may be prepared by steeping in water for several hours, maize takes a very long time to soften and linseed at least two or three days. This is a good method to adopt when crushing appliance does not exist, or where, as in the case of linseed, it is not always

convenient to boil the grain. Care should be taken that it is not carried to excess and fermentation produced, which would certainly be productive of intestinal disturbance.

#### *Germination.*

This has been dealt with when speaking of 'malt' (p. 246).

#### *Fermentation.*

This has been described as a good method of preparing straw for fattening cattle and sheep, by which means it is said to be rendered more soluble. The straw is mixed with the other food ingredients and damped, being allowed to remain until fermentation occurs. How far this is a reliable method in practical feeding there is not much evidence to show.

Ensilage, which is only another form of fermentation, has previously been dealt with (p. 231).

#### *Cooking.*

Food may be cooked by steam or by boiling in the ordinary way. The foods so dealt with are the various grains including linseed, and certain 'roots,' such as potatoes.

It is mainly in the fattening of cattle that the steaming or cooking of foods is employed, for there appears no doubt that boiled foods induce the deposition of fat. They are frequently given to horses on this account in order to prepare them for sale.

We have in previous pages dealt with this question of boiled foods for horses, and set our face strongly against the process for animals in health. We raise no such objection in the case of fattening cattle, for here there is no question of their being kept under physiological conditions.

It is said that the steaming of straw and hay increases their digestibility, but by others this is denied, and experimental enquiry shows that as a rule there is a loss of

digestible proteids as the result of cooking; it appears, however, to increase the palatability of these foods.

Hay infusions made with boiling water, extract the bulk of the proteid matter which is very soluble in water. 'Hay tea' as it is now termed, has been used with other substances as a milk substitute for calves and foals, but is principally of use as a hospital diet.

The boiling of calf food and that intended for the rearing of foals by hand is no doubt essential, it is only natural that the starch converting power of the pancreas of these young animals should be very weak, and the cooking of starch

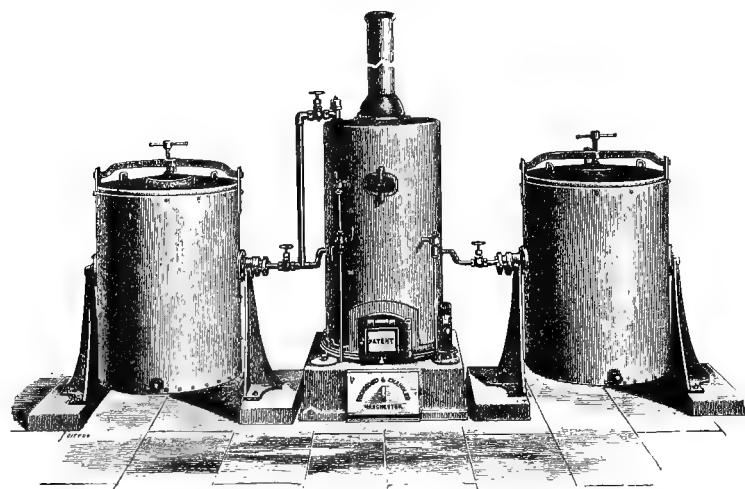

Fig. 79.—Vertical Steaming Apparatus (Richmond & Chandler).

(which is of course not a natural ingredient of their diet at this early age), facilitates the action of the pancreatic juice.

The boiling of linseed is essential in order to liberate the mucilage; this can be obtained by infusion but it is a much slower process.

The cooking of rape cake in order to destroy its hurtful properties has been previously dealt with (p. 257).

*Parching* is employed in India for the preparation of barley. *Mashes* of bran are prepared with boiling water, thoroughly incorporated, and allowed to stand until cool

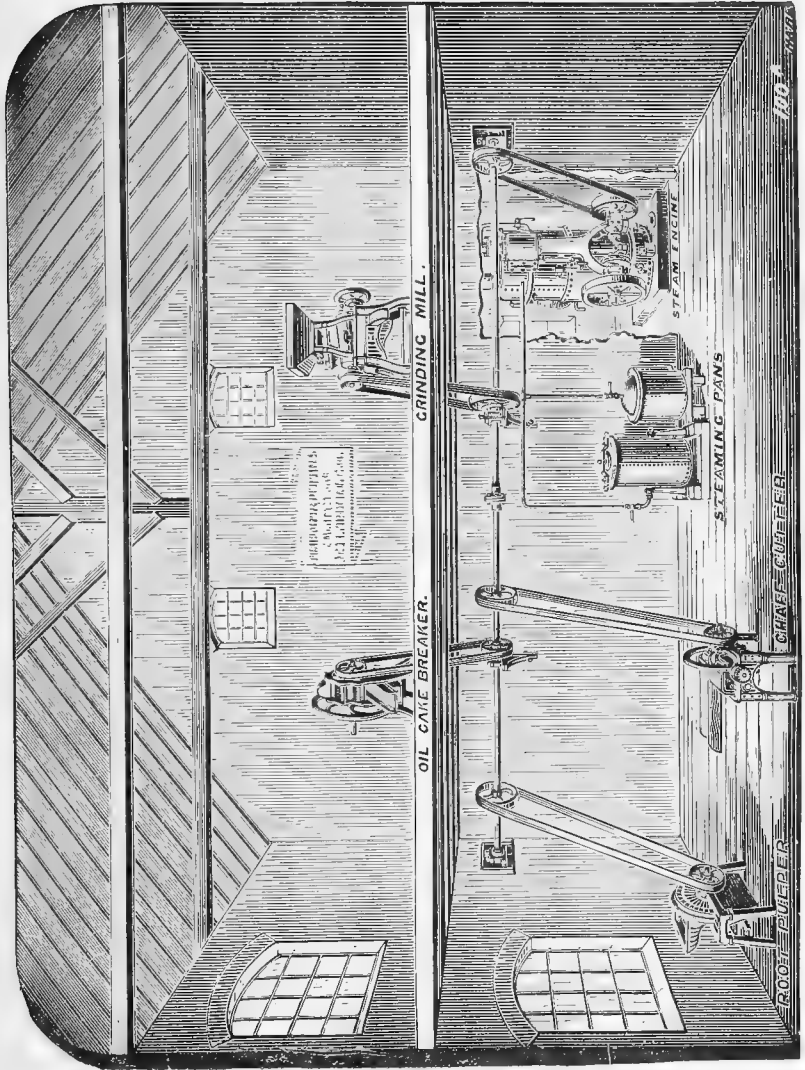

Fig. 80.—Model Set of Food-Preparing Machinery (Barford and Perkins).

enough to eat. *Gruel* is made with boiling water poured on the oatmeal and covered up until used, or as a hospital diet cooked in the ordinary way.

*Distribution of Food.*

In large establishments this should be under certain selected men, and no one else should have access to the store. All issues both in large and small stables should be made by weight and the use of measures abolished ; by this

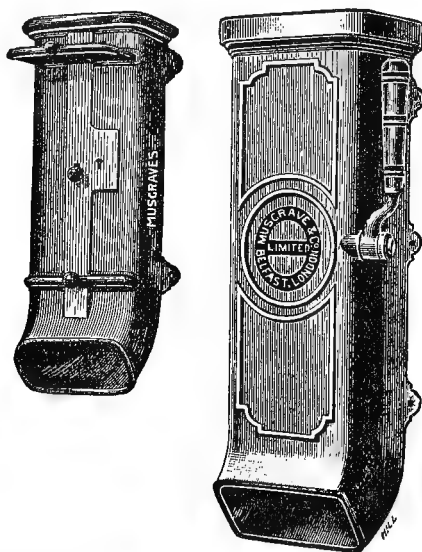

Fig. 81.—Corn Meters for use in private stables, they hold a definite weight of corn ; the smaller one is arranged to lock. Both of these meters are connected by a shoot with the forage loft.

it is not intended to be conveyed that no measure should be employed. It is very convenient for the purpose of issue to have measures holding a *definite weight* of each substance.



## CHAPTER V

### HABITATIONS

THE question of accommodation for animals is a rather complex one, for the reason that the details which apply to horses are unsuitable for cattle, so that the matter must be considered separately for each animal. The cause of the difference is not far to seek, the horse pays for itself by the work it performs, cattle only pay for themselves by the sale of their milk or their flesh; during the interval between lactation, or during the time the animal is accumulating flesh for the butcher, it is unproductive.

This latter statement must be somewhat qualified, cattle are not entirely unproductive either when 'dry' or fattening, for there is the value of their manure to be taken into consideration, and strange as it may appear, the whole question of their feeding, the disposition of the buildings in which they live, and the sanitary conditions under which they exist, hinges on the question of manure.

Without this manure the farmer could never afford to feed his animals as he does. He pays £8 a ton for linseed cake because he knows he gets practically half his money back in the manure, so that during the otherwise unproductive life of the animal every effort is made to secure the whole of the liquid and solid excreta, as representing so much floating capital.

With horses this does not apply. The bulk of their excreta is deposited in the streets, and what may be saved from passing down the stable drains only represents half, or less than half, of the total amount produced. This may

or may not be sold, but the scheme of stable construction is quite uninfluenced by any question of manure, while in the case of cow and cattle houses it is the primary consideration. Hence, though the general principles of construction must remain the same for the two animals, yet the details differ widely.

*Site, Soil, Aspect.*—It is usual to discuss the question of site in dealing with buildings, but it must be apparent that in towns and cities the question of a suitable site does not enter into the matter, such land as may be available has to be utilized. So in the same way aspect, sunlight, protection from cold winds, water supply, drainage, are all questions which in the case of towns and cities are never given the least consideration, for the very good reason that it is seldom any choice can be exercised, as any available piece of ground is secured, and the best made of it.

The worst soils that can be selected for building purposes are low-lying sites near rivers, where the ground is more or less alluvial, viz., very largely composed of organic matter washed down by the river. We are well aware that the banks of our tidal rivers in the vicinity of cities are built upon to the water's edge, and often on reclaimed ground, but such sites from a sanitary point of view are undesirable.

Reclaimed ground especially in the vicinity of cities is most undesirable, as a rule it has been reclaimed by the deposition of refuse, and this takes some years, probably never less than three, before it is fully destroyed; such sites are if possible to be avoided.

In the country it is possible to give these questions some consideration. In the matter of building a homestead, it is evident that the driest soil on the farm should be selected, a deep gravel or chalk for choice and not a clay. There are, it is true, other considerations which influence the choice of site, such as having the homestead in a fairly central position, and its proximity to a good road or railway station, but these should not overrule the question of a dry soil.

Shallow gravel and sand upheld by a basin of clay are far from healthy, and clay as a site must be avoided if dryness of the building is to be secured. Damp soils are known to be productive of disease, though of course they may be improved by drainage. (See Soils.)

The position should be such that drainage is secured, but in dealing with this side of the question it must not be forgotten that the conditions which will secure excellent drainage may seriously interfere with the water supply, for instance when the water has to be pumped to the farm from some distant source. Under any circumstance the water supply must be abundant, or the place had better not be built.

It would be a wise precaution in all cases where the existence of water is not evident, to spend money in sinking a well, and assuring one's self of the permanence of the supply before a brick is laid; and while this is being done the height of the ground water at the proposed site of the buildings can be ascertained.

The ground water should not be nearer to the surface than eight feet, and if it is fifteen or twenty feet below the ground line so much the better.

If water is obtainable in abundance, the soil good, such as deep gravel, chalk, or rock, and the position sufficiently elevated to secure drainage, then the question of aspect may be considered.

It is generally believed that a S.E. or S.W. aspect is the most advantageous, perhaps that one which gives the greatest shelter from the coldest wind would be the best general statement. In the building of a homestead great advantage may be taken of putting larger structures like straw barns, granaries, and food stores, in such a position as to break the cold wind before it enters the part occupied by the animals.

Another point to consider is sunlight, especially in the case of buildings in towns and cities. Dark stables can never be healthy, the influence of sunlight in controlling disease is remarkable, and when opportunity exists as in

planning farm buildings, or where the site is not restricted, the stables should be so arranged as to get the largest amount of sun.

In tropical and subtropical regions, on the other hand, they should be arranged so as to get the least amount, with the object of keeping them cool. This being so they should face north and south, so that at the hottest time of the day the sun is end on to the stables and not side on.

#### CONSTRUCTION.

*Foundations.*—It is usual to make these of concrete, the base thus prepared being four times the breadth of the wall. On this concrete bed rests the 'footings' of the wall, and as the latter rises above the ground level, a precaution against damp is taken by the introduction of a *damp-proof course*.

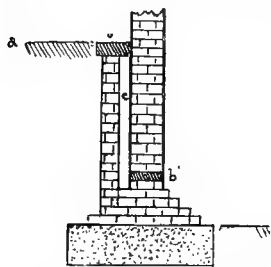

Fig. 82.—A Damp-proof Course. *a*, Ground level; *b*, vitrified stoneware tile; *c*, air space between two skins of brick work.

This may consist of a layer of asphalt poured over the wall, or sheet lead, or slate laid in cement, but perhaps the best is the vitrified stoneware tile embedded in cement, and the latter is especially necessary where the stable floor will

be below the level of the outside ground. As a double security against damp it is usual with walls of this description to build them hollow, and have a second damp-proof course above the ground as in Fig. 82. The soil should also if possible be kept away from the brick work.

The vitrified stoneware tiles are usually perforated (Fig. 83), but for stable purposes this is unnecessary, though for buildings where wooden floors are used they are of the greatest service in ventilating beneath the floor, and saving the wood from destruction.

*Bricks.*—The bricks employed for walls are of three kinds, viz., those from pure clays, viz., alumina and silica,

those from loam or sandy clay, and those from marl or lime clay. Fire bricks are made from clay containing neither lime nor magnesia.

The colour of a brick depends upon the degree to which it is burned, and the amount of iron and lime it contains. Its average size is 9 inches long, by  $4\frac{1}{2}$  inches broad, and 2 inches thick. Its average weight is 5 lbs., and it can hold about sixteen ounces of water: it is therefore very porous.

The thickness of a wall is described as consisting of so many bricks, for example a one brick wall is a nine inch wall. Bricks, as we have seen, are very porous, and air can under very little pressure be driven through them. There are special non-porous bricks, known as Blue Staffordshire, which are excessively hard, and owing to their being practically non-porous are largely used for stable flooring.

Bricks are laid in courses, and mortar should be used not only between the courses, but also between the vertical joints, so that no two bricks should touch each other. The care with which mortar is applied is a good test of the thoroughness of the work. Mortar is made from one part of quicklime and three parts of clean sharp sand. Sand from the sea shore makes a bad mortar, and leaves a damp wall.

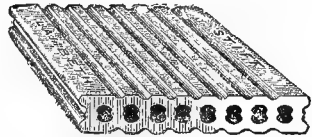

Fig. 83.—Vitrified Damp-proof Course.

*Roofing.*—The material used in roofing may be tiles, slate, thatch, or galvanized iron; the latter is very durable, but is a hot or cold cover depending on the season; slates make a good water-tight roof, while the tile is perhaps too brittle, though extensively used in farm buildings. Thatch is the warmest roof that can be supplied, but is obviously dangerous.

The eaves of the roof should project beyond the walls so as to save them from rain, and should also be provided with a good gutter for carrying off the water. It is poor

economy to put a damp proof course in the wall, and then saturate the foundation either by having no gutter or a defective one.

The style of roof employed is either the ordinary closed one or the open roof. The latter may be described as a contrivance for the admission of fresh or the escape of impure air through the roof. It is usual to provide this opening along the ridge (Fig. 84), either for its full length or at intervals protected by a louvre which keeps out the rain. But the roof need not necessarily be open at the ridge, it may open midway between the ridge and eaves as in Fig. 85, a plan largely adopted in arranging the ventilation of covered yards for cattle.

If slates are used a good ventilating roof may be obtained by not allowing the edges to meet, the method being known

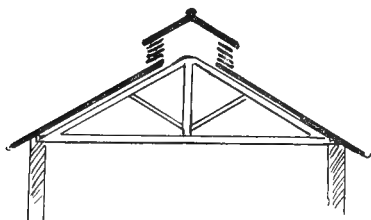

Fig. 84.—Ridge Ventilator with Louvre

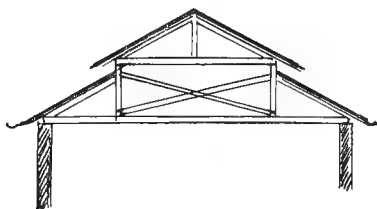

Fig. 85.—Open Roof.

as open slating. In the space left between the edges—which is about  $2\frac{1}{2}$  inches—the air finds its way through an opening which is only the thickness of a slate, but which when spread over the whole roof represents something very considerable.

Wood covered with felt or waterproof paper makes a useful light roof for small buildings, but is hardly sufficiently substantial for permanent ones.

Though there is a prejudice against them in some quarters, galvanized iron both for walls and roof will probably play an important part in the future. Buildings in galvanized iron are now made in convenient sizes for many agricultural purposes; for stables, cow houses, or boxes for

fattening cattle, they may be considered too cold in the winter, but as roofing for covered yards, manure pits, hay ricks, temporary sheep shelters, etc., they are of undeniable value.

A roof known as the 'open board roof' is frequently used on account of its cheapness, it has the further advantage of being a ventilating roof. The principle of construction is simple, the boards are grooved at either edge; when they are laid on the roof they are not permitted to touch each other, a space of about one quarter of an inch is left between them; the rain strange to say does not find its way through, and what runs down the board, is carried off by the two grooves on either side.

These boards are not nailed direct to the framework of

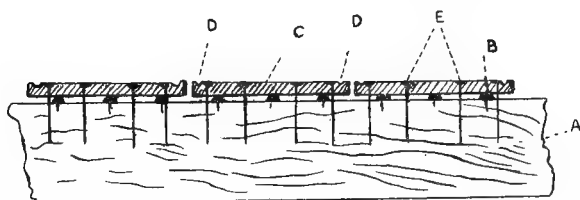

Fig. 86.—Open Board Roof. A, Frame of roof; B, studs driven in the frame to keep the boards, C, from touching it; D D, two grooves on either side of the boards to carry off the rain; E, long nails to secure the boards to the frame (Henderson).\*

the roof, but some small studs are first driven into the frame and on these the boards rest. When in this position they are kept there by long nails driven into the frame beneath. The advantage of the studs is that the wood work of the frame and roof are not in actual contact, in consequence of which the wood is preserved by the circulation of air. In Fig. 86 a section of this class of roof is shown;\* it is frequently used for covered yards.

The gutters around the eaves of a roof are, as previously mentioned, of the utmost importance from a sanitary point of view in keeping the soil dry around the foundations;

\* Copied from 'Dairy Buildings,' Mr. R. Henderson, *Transactions of the Highland and Agricultural Society*, vol. xi.

further, they have their economic aspect, for the whole of the water from the roof should be collected by means of tanks and other contrivances, and the pipes from the gutter should open into these, and not into the sewer system of drains as is frequently the case.

The *Inside Walls* of the building if of brick should be plastered, and around and above the mangers cemented for the sake of cleanliness. In some high class stables the wall for half its height is tiled, and from a sanitary point of view this is advantageous. In industrial stables the walls will probably present the bare brick lime washed, and to this no exception can be taken on the score of health, though cementing the wall above and around the manger should if possible be carried out, as this part is so much exposed to soiling.

Colour washing stables is preferable to white washing, a neutral tint being employed which can readily be made by mixing lamp black with the white wash; it takes off the glare from the walls, though in stables indifferently lighted the white wall is advantageous.

The walls of cow byres may be dealt with the same way, while the partition walls of fattening boxes should receive a coat of lime wash on the score of cleanliness.

*Ceilings.*—It frequently happens that a building is in two stories, the stables being on the ground floor and human beings or forage above. In such cases the ceiling of the stable must be rendered air-tight, both in order to prevent the forage becoming tainted or the dwelling rooms affected.

Where horses are standing in three or four stories, as in many city stables, an absolutely impervious and fire proof floor is necessary, brick, cement, and iron being employed, the impervious floor of one storey being the impervious ceiling of the other.

*Lighting.*—One great defect in all old stables, and in many modern ones, is insufficient lighting. Light is absolutely essential to health, if it cannot be obtained through windows owing to neighbouring buildings, it must be obtained through the roof, but no effort must be spared to



secure all that is available, so that apart from the question of ventilation considered in an earlier chapter, the windows as a lighting medium of all places intended for the housing of animals, is a most important point to attend to.

We have recommended the Sheringham window or any working on this principle (see p. 68), but at all costs windows or lighting must be secured. It is just as essential for cow houses as for stables, even, if possible, more so, for the city cow never moves out of her stall, while the cab horse spends ten hours a day in the open. But all must have it; the loathsome condition of some cab stables defies description, lighted up by a gas jet even in the daytime, the atmosphere so irritating that it brings tears into the eyes, hot, damp, muggy, filthy, with no inlet or outlet other than the door, while if a window exists its broken pane is sure to be covered up with a piece of sacking.

Of this type of stable thousands exist in our large cities; no wonder the life of a cab or small proprietor's horse is a short one. The extraordinary thing is that the animal's system tolerates such a state of affairs for fourteen hours out of the twenty-four.

There are many industrial stables underground, the system is a bad one, but cannot be helped in cities where space is difficult to secure and most expensive.

The lighting and ventilation of such stables is almost waste of time to discuss, the lighting must always be artificial while the ventilation, with probably three more stories of horses overhead, must depend upon local conditions, which generally speaking afford no help, so closely hemmed in is the place by other buildings. Mechanical ventilation is the only thing possible in such cases.

In the country all this is different, there is no reason why the private stable, or the stable and cow byres of the homestead, should not be both efficiently ventilated and lighted. There is absolutely no excuse, the difficulty here is to overcome the preconceived prejudice of the owner and landlord, and though enlightened farmers and horse owners exist, they are the exception rather than the rule.

Reforms move slowly but surely, public opinion has taught the farmer a great deal about the care and preservation of milk and the hygiene of the dairy that he otherwise would never have learned; it will yet teach him that the animal that produces the milk must also be maintained under sanitary conditions.

*Paving.*—The paving for buildings has always been a difficult question, especially that for horses, as there are two essentials to be filled, viz., it must be water tight and it must not be slippery. The only difficulty is to obtain a non-slippery pavement, and this will always be the case until some other material than iron is found for horses' shoes.

The floor should if possible be above the level of the outside ground in order to ensure a fall for the drains or gutters, and whatever paving material is employed, it must

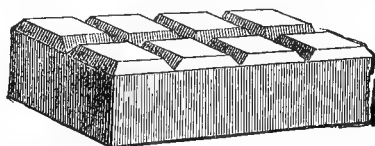

Fig. 87.—Vitrified Paving-brick (St. Pancras Iron Works Company).

rest on a good solid bed of concrete. It is astonishing how holes are worn in floors and sinking occurs under continuous pressure. We see it at its best in the street pavement in spite of a concrete foundation.

Many materials may be used as flooring, perhaps the blue Staffordshire brick (Fig. 87) is the most economical. These bricks on their wearing surface are frequently divided by grooves into smaller squares, the idea being to prevent slipping; but until grooves are made wide enough and deep enough to get the toe of the shoe and foot into it, it is difficult to understand how they can prevent slipping. A brick with a single wide groove is made, which more nearly fulfils the necessary condition. At present, it may be said no vitrified stable brick exists which will prevent slipping, so that other measures like sand should be adopted to secure this object.

The grooves in these bricks fulfil another object, they direct the urine towards the drain and for this purpose they are useful.

Cubes of granite square cut and set in cement make a very good floor for industrial and military stables, they are as slippery as bricks but very durable.

Cement floors laid on concrete and grooved for the purpose of urine, drainage, and foot-hold, are sometimes used. They appear to be less durable than bricks or granite, and are of course slippery.

Asphalt laid on concrete fulfils all the conditions of a water-tight floor, but is slippery and never used for stables if it can be avoided.

It is usual to give a slope to the stable floor for the purpose of drainage. The slope to a stall, like many minor matters capable of being grasped by the layman, has been a fruitful source of discussion. If it is recognised that the object of a slope is simply to carry off water, and that any departure from a horizontal surface for the horse to stand on is an evil, then common sense dictates that the slope should be the least possible in any direction; as the least slope in any direction determines a fall, nothing more is required. If the stall is an inch lower behind the horse than it is in front, that settles the question of which way the urine will run and more than that is not needed; the slope of the gutter behind must do the rest.

Slopes have been made excessive, the horse's hind quarters being much lower than its fore; this is unnecessary and uncomfortable, though in spite of what has been written and said we do not think anyone has seen harm arise from it.

Sometimes the slope given to a stall is not only from front to rear but from side to side, while in the case of a box a slope is sometimes given from all four sides towards the centre when underground drains are used.

Where bricks with grooves are used as a flooring for stall or box, it would be a very simple matter to place the horse on a perfectly horizontal surface by graduating the

depth of groove in the brick during its manufacture, and secure sufficient fall for drainage by means of the grooves, instead of placing the floor at an angle.

The greatest ingenuity has been displayed by stable constructors in arranging their paving bricks in various patterns and devices; sometimes they run diagonally towards the centre, sometimes at right angles, and occasionally herring bone pattern. From a point of utility this is quite unnecessary, but it perhaps appeals to the æsthetic sense. Such conditions are only found as a rule in high class stables, and the constructors always claim some practical advantage for the pattern adopted which does not exist. The only exception to this rule is in connection with

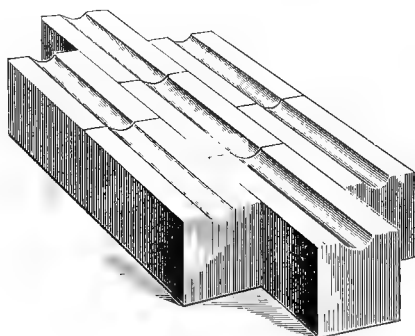

Fig. 88.—Vitrified Paving-brick with Single Groove.

the brick with a single groove (Fig. 88). It is obvious if this is to prevent slipping, it must be placed at right angles to the stall.

The floorings we have spoken of have been ideal from a sanitary standpoint, but they only represent a fraction of the floors employed in stables. The usual one in poor stables is the round cobble stone set in mortar, rough to walk over, soon wobbles on its bed of earth, sinks, allows urine and liquid excreta to find their way between the joints, with the result that the earth beneath turns the colour of ink. The constant saturation causes the floor to further subside, and in such a stable in addition to the gases of respiration are added those of decomposition, for

the ground beneath the broken pavement is of the character of a cesspit. Such floorings are found everywhere in the poorer class of stable and byre.

An ideal non-slippery floor would be sheet lead, though its life in a stable with horses wearing calkins or having itchy legs would be a very short one. It certainly might be employed in the stables of the wealthy as a flooring impermeable to moisture, and on which it is equally impossible for a horse to slip.

The flooring used for cattle byres is as a rule any stone obtainable, or even wood. Wooden floors are most insani-  
tary and may be at once dismissed from consideration.

The only conditions under which cow houses are likely to be provided with a suitable flooring, is through the Dairy, Cowsheds, and Milkshops Order, but applied by a Central and not a Local Authority, and this should insist on an impermeable floor of cement or asphalte set on concrete. The stall for a cow practically needs no slope under the animal, as the urine is voided directly behind, generally into a surface drain placed for the purpose, but this matter is dealt with later.

The flooring of fattening boxes and hammels for cattle, is generally sunk two feet or more below the surface, and in the better class of homestead is concreted below and at the sides. This shallow pit is for the reception of the manure and urine voided during the many weeks or months the animal is standing there, and is trodden into a compact mass by the daily addition of a little straw. It is a filthy system, but not likely to be changed so long as it is economical of manure and saves labour. We shall allude to the matter later on.

The flooring for piggeries should be the plain blue Staffordshire brick set in cement. A fall is needed for drainage. Some breeders place a wooden platform at the back of the sty for the pig to lie on; if employed it should be capable of being removed for the purpose of cleansing and disinfection.

There is still something more to be said about paving,

but as it overlaps the question of drainage, it will be considered in dealing with that subject. (See Disposal of Excreta.)

We must now enter more fully into the special arrangement of buildings intended for animals; up to the present we have only been considering the general principles applicable to all.

#### STABLES.

In no class of building have such sanitary improvements been made in the last forty years as in stables. The view is no longer held that any place is 'good enough for horses,' and many of the structures and interior decorations of high class stables leave nothing to be desired (Fig. 89). Some of the interiors of high class stables are not only arranged on sanitary principles, but the fittings are an object of art. A revolution has been accomplished in industrial stables in recent years. They are now frequently well lighted, paved, drained, ventilated, with ample cubic space and superficial area, and no more than these can be desired for any structure (Fig. 90).

In other words, a change has come over public opinion in these matters, and this has been gradually but silently effected by the veterinary profession, in spite of it having to deal with the narrowest minded and most conservative class of human being.\*

Stables may conveniently be considered under three classes: viz., high class, middle class, and industrial stables.

\* No doubt the care of horses is the work of a skilled labourer, the ordinary horse owner knows nothing of the subject, and places himself unreservedly in the hands of his servant. The latter soon exercises a despotism over the owner, so that the groom or coachman's word and opinion become law, and are observed as such throughout the length and breadth of the kingdom.

The farmer is no less narrow and conservative, but thanks to a better educated class interesting themselves in agriculture, and to the excellent schools in which they have been trained, opposition to reform is greatly reduced, and our work made correspondingly easier.



Fig. 89. — High-class Stable (Mitsugawa).

To face p. 154.







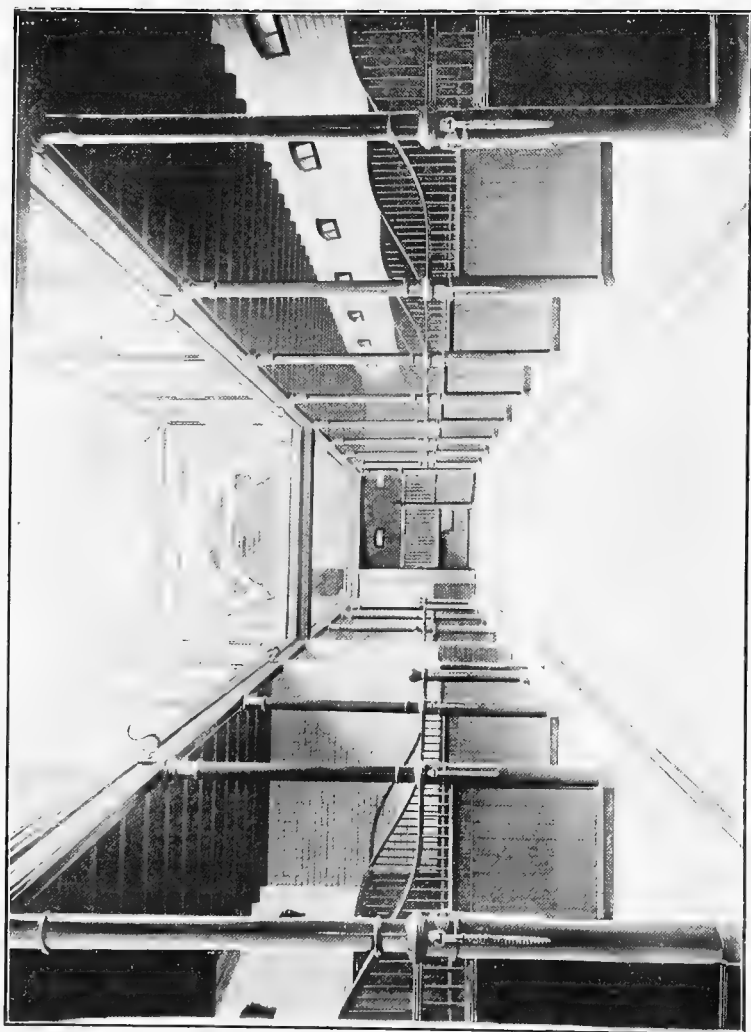

Fig. 90. — Industrial Stable arranged on Sanitary Principles (Musgrave).

In principle all three are the same, in detail they differ greatly, the question of detail being a matter of cost, and in no wise necessarily affecting their sanitary condition.

*High Class Stables.*

Site, aspect, and soil having been considered generally, it is unnecessary to again refer to the matter, so that we

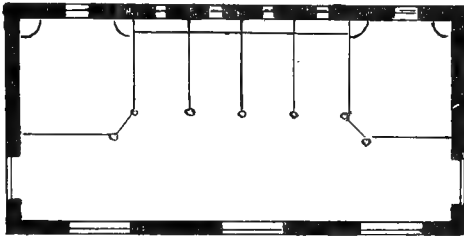

Fig. 91.—Ground Plan of Stable with Four Stalls and Two Boxes. Single row.

may at once deal with the general ground plan of the buildings.

*Type.*—This depends upon the number of horses that have to be provided for, but the principles are very simple. A single row of animals (Fig. 91) running the length of the building is always better than a double row. Horses

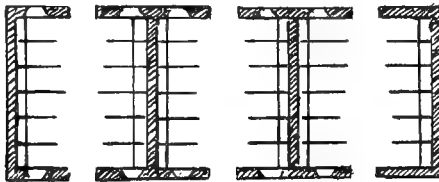

Fig. 92.—Transverse Arrangement of Stalls.

should never be placed across the stable (Fig. 92), this is known as the transverse arrangement, and brings five or six animals between opposite sources of air supply which is bad.

A single row as recommended means, of course, extra ground space, and this may be an impossibility; in such cases a double row is the only alternative, but the animals'

heads should be turned towards the walls and not towards the centre of the stable as in Fig. 93. A single row recommends itself on the ground of ventilation, more floor space, and frequently better lighting.

In Fig. 93 is shown the general plan of a stable and attached buildings.

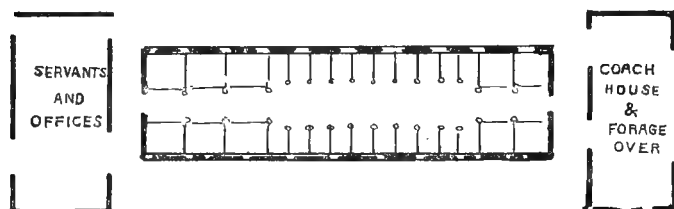

Fig. 93.—Ground Plan of Stable for thirty horses with ten loose boxes.

Living rooms over the stable are bad, as they interfere with proper ventilation, see Fig. 95.

*Windows.*—The next points to provide for are the windows and doors; there should at least be one window of the Sheringham valve type for each horse as mentioned on p. 68, and these should be placed overhead. Figs. 4 or 5 are the best types of overhead window, while a larger window

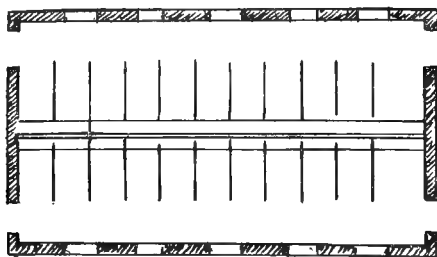

Fig. 94.—Ground Plan of Stable with double row, the horses' heads being turned towards the centre, which is a bad arrangement.

is used as a means of lighting in the wall behind the horse (Fig. 97), and is the additional advantage just claimed for a single row of horses in a stable.

In a double row the ventilating windows should be like Fig. 96, over each head, without which the stable will be defectively lighted.

*Doors.*—Doors are frequently made too narrow, with the result that the hip is very liable to damage if the animal is carelessly led in.

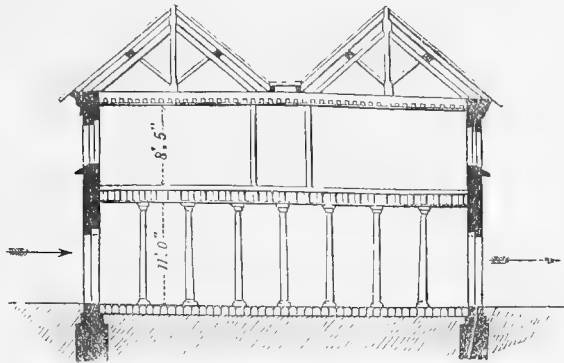

Fig. 95.—Transverse Section of Stable with living rooms overhead. Eight horses are placed between opposite windows, with their heads to dividing walls. There is only ventilation from each end.

To prevent this class of accident every stable door should be provided with rollers, and must be wide enough to

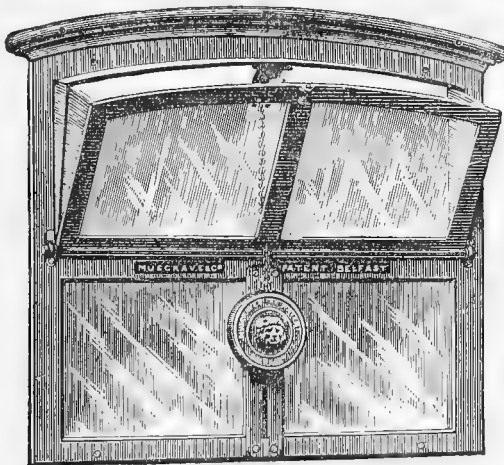

Fig. 96.—Sheringham Ventilating Window (Musgrave).

admit of a horse being able to pass freely through, viz., not less than 3 feet 8 inches. In Fig. 89 a roller may be seen on the door to the right.

The height of the door is another consideration. It is true the low doors of days gone by have disappeared from all high class stables, but it is perhaps not known that their disappearance was due to the injury they caused to the poll of the animal in passing through. The door should be high enough to much more than prevent the biggest



Fig. 97.—Ventilating Window (Musgrave).

horse from touching its ears when the head is erect, and this height may be placed at 8 feet.

From a sanitary point of view a door in two halves, upper and lower, is preferable, as it allows of the upper half being left open in fine weather, with less chance of

draught. Where whole doors are used it is always desirable to have a bar which may be placed across them, so that

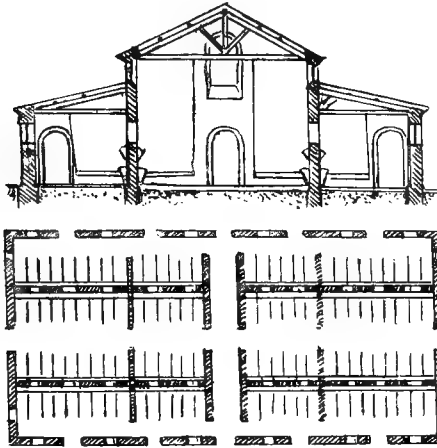

Fig. 98.—Ground-plan and Section of Industrial Stable, showing two double rows of horses between opposite sources of air supply. This is an aggravated condition of the bad arrangement shown in Fig. 94.

when left open in the summer no horse can escape in the event of it getting loose.

The *handles and latches* of doors are most important, there should be no sharp projections anywhere, every projection must be rounded, or preferably no projections of

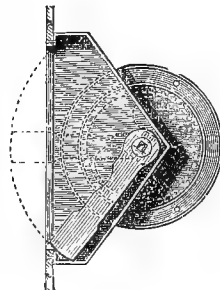
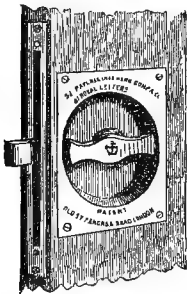

Fig. 99.—Harmless Latch.

Latch seen in Section.

(St. Pancras.)

any kind, the lock being countersunk. This especially applies to the doors of loose boxes ; if there is a projection

the animal is sure to damage itself. Fig. 99 shows a countersunk and harmless latch which can only be opened from the outside, and is especially valuable for a loose box



Fig. 100.—Harmless Latch.



Inside View of Fig. 100.

on that account. Fig. 100 shows one of another type with a harmless handle, this latch can be opened from the inside through the countersunk holes. There should be no springs to these latches, they are of the bolt class, and the bolt is out of harm's way when the door is open.

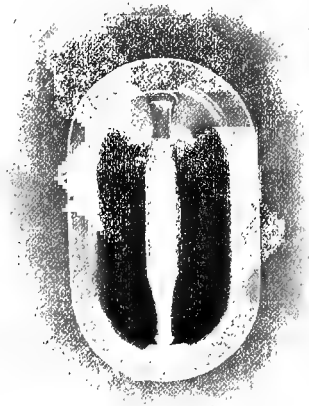

Fig. 101.—Flush Handle, sliding door for loose box (Musgrave).

For sliding doors, such as are frequently used for loose boxes, a flush handle is frequently employed (Fig. 101). Any pattern which gives safety to the horse, and does not



admit of being interfered with by him during his hours of idleness, may be employed.

The door of a loose box should either be sliding or open outwards, on no account should it open inwards, as it is then only opened with difficulty when the bedding is down. The width of a loose box door should not be less than four feet.

The number of outside doors must depend on the length of the stable; the question of exit in case of fire should not be forgotten, and there must not be too great a length of stabling without a door.

The *Inside Walls* should be impervious and capable of being cleaned, tiles of various tints, neutral, green, ivory, etc., may be employed, or slabs of marble. White is not a desirable colour, excepting in a dark stable, owing to the glare. These impervious walls may be rendered handsome in appearance, and are extremely sanitary, for they readily admit of being swept and cleaned, and this is particularly important with that portion immediately above the manger.

The lining of boxes must be wood carried up to the level of the top of the manger.

The *Roof* should be open to the outside air by ventilating tubes in the ridge. These tubes should be surmounted by a fixed extraction cowl (see p. 73), and the number of these must depend upon the number of horses in the stable. This matter has been fully discussed under Ventilation to which reference should be made. It may, however, here be noted that these tubes are only of use in small stables; where a large number of horses are brought under one roof, ridge ventilation by louvres under control should be adopted; the only reason for putting the louvre under control is to be able to alter the size of the opening in very windy weather, or prevent snow drifting in.

The roof of the stable will most likely be a closed one, as over head is demanded for lofts and perhaps sleeping accommodation. It is a bad arrangement, but if it has to be adopted the ceiling must be so arranged that extraction tubes surmounted by cowls are carried through to the

ridge of the building, and on the lines previously laid down.

It may at once be stated that closed roofed stables as a rule can never be successfully ventilated by natural means, excepting there be only a single row of horses in a stable and opposite windows.

The *Paving* has been previously dealt with on p. 282, but both it and drainage will be further considered in the chapter devoted to the latter.

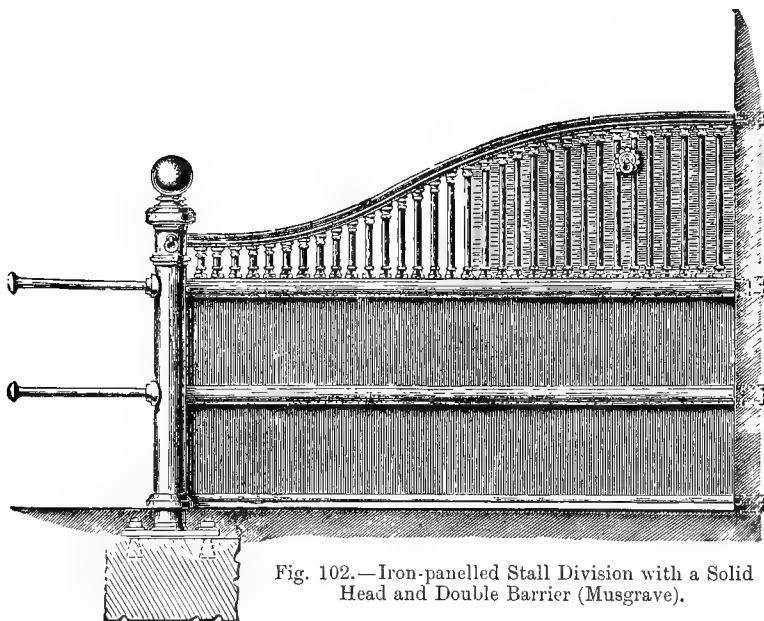

Fig. 102.—Iron-pannelled Stall Division with a Solid Head and Double Barrier (Musgrave).

It is in the matter of fittings that stable constructors have been particularly successful; these may now be had of any degree of durability and artistic design.

*Stall Divisions.*—The stall partitions should be strong, carried up high enough in front to prevent horses quarrelling, and made with a solid head as in Fig. 102 to prevent them annoying each other. Some of the stall divisions are made of wood with iron supports, others of iron throughout, no wood being used for the purpose of panelling. The

upper outline, or ramp, is made of various curves, depending largely on the fancy of the designer, while all the better divisions are fitted with a double or single sliding barrier (Fig. 103), which can be pulled out of a socket at night, and drawn across the stable, where it is fixed to the opposite wall. In the event of a horse getting loose at night, there is no chance of him wandering about and getting kicked.

It is obvious these barriers can only be conveniently employed in stables where there is a single row of horses.

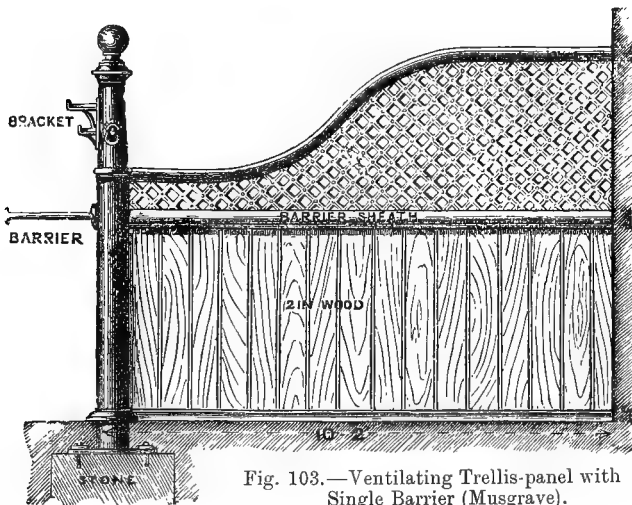

Fig. 103.—Ventilating Trellis-panel with Single Barrier (Musgrave).

Various kinds of stall partitions are shown in Figs. 102 to 105.

Sometimes the woodwork of the panel is arranged horizontally so as to save it as much as possible from a kicking horse, but the best protection against this class of vice is a proper kicking mat such as may be seen in the stalls of Fig. 89. Most panels are made with a shifting piece which allows of new boards being inserted if they get broken.

The stall division should not touch the ground, there should be a space between it and the floor, so as to prevent the woodwork getting wet when the floor is washed.

Frequently the *rear pillar* of the stall has to assist in supporting the ceiling, and occasionally it is arranged with a bracket to hold a saddle temporarily, or for any other purpose. This is quite wrong, no bracket of any description should be fixed to the pillar, it is the most frequent cause of injury to the head particularly the eyes. The pillar must be rounded and free from any projections, and surmounted by a ball top. The only thing which it is permissible to attach to the pillar are the chains, which should be connected to a ring, and be protected at the other end by a

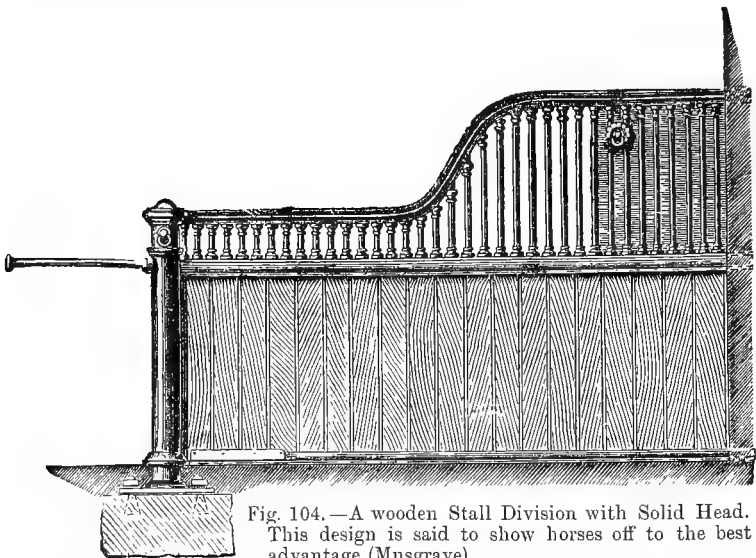

Fig. 104. —A wooden Stall Division with Solid Head. This design is said to show horses off to the best advantage (Musgrave).

spring hook. When not in use the pillar chains should be hooked up.

The stall divisions should not, as a rule, be less than ten feet long from manger to pillar, this is in many cases a foot longer than generally employed, but whether for appearance or from ignorance stall divisions are seldom made long enough, and severe injury may be inflicted by a kick behind the post. Some stalls are so short, and in consequence injury so frequent, that they are lengthened by a movable piece the shape of a ship's rudder, and attached like one to

the heel post, but the most efficacious method is to have a good long stall, never less than ten feet from manger to pillar, and longer if necessary.

An average horse covers eight feet of ground, and the average length given to a stall is ten feet from wall to pillar. If 18 inches are taken off for the manger, it reduces the actual length of the partition to eight feet six inches. But the animal never keeps close up to its manger except when feeding; the majority of horses stand back in the stall to the extreme length of their collar shank,

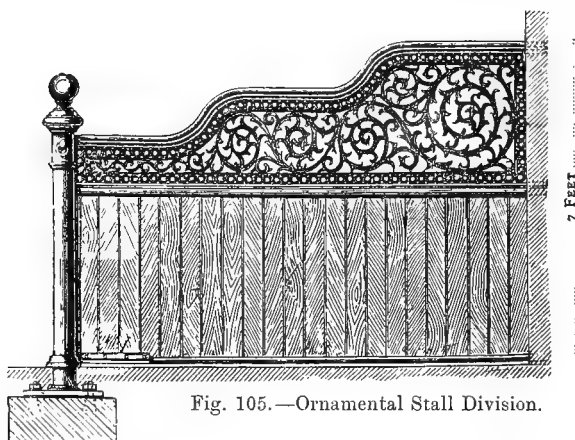

Fig. 105.—Ornamental Stall Division.

and if they can place their hind feet in the drain behind they will do so. In this position they may readily be kicked.

The length of the stall division should be measured from the manger and not from the wall. Nine feet from the manger should be the irreducible minimum, and most horses will require ten feet. The width of the stall from partition to partition should never be less than six feet.

If we have spent some little time discussing what may seem a somewhat trifling question, viz., a stall partition, it is for the reason that in stable management it is a question of the utmost importance, more than half the injuries that occur in the night are due to kicks, and a large percentage of these could not occur if stalls were made longer. Most

of the stable repairs are to stall divisions, and this tells its own tale of the violence to which they are exposed.

*Loose Box Divisions* are generally made to agree in design with stall divisions, so far as the mouldings of their iron work are concerned, but are more strongly and solidly constructed, as they are at times exposed to great violence. In size a box ought not to be less than twelve feet square, and may with advantage be larger. The pillars and panels are stronger than those of stalls, and the door should be sliding or open outwards as previously mentioned. On no account should there be a lintel above the door, or the horse will

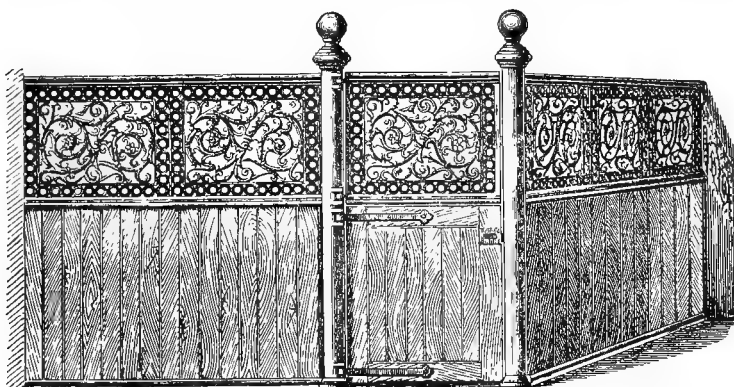

Fig. 106.—Loose Box Division, agreeing in design with Fig. 105.

certainly knock his head on entering. The door should be four feet wide, it is always made smaller than this which is a mistake.

The fittings of loose boxes are generally made seven feet high, the iron panels or railings being about three feet deep. Some loose box divisions are shown in Figs. 106, 107. There is an idea that a large loose box prevents a horse getting 'cast' during the night. But this is only true up to a certain point; he is more likely to be cast in a small than in a large box, but beyond twelve to fifteen feet square, depending on the size of the horse, no additional safety is secured by size. This point will be referred to more

fully in the chapter dealing with the management of horses.

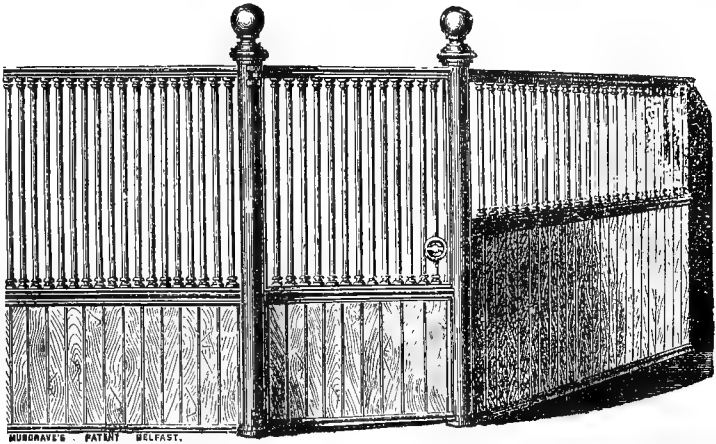

Fig. 107.—Loose Box Division (Musgrave). Design agrees with Fig. 102.

*Mangers.*—Much of the ingenuity of stable constructors has been devoted to mangers, with the result that a great

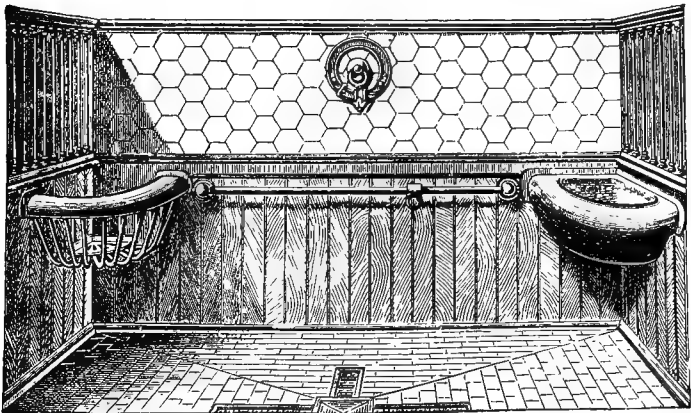

Fig. 108.—Loose Box Manger.

number of different patterns exist. They have brought common sense to bear, and produced a manger which is harmless, and further have secured cleanliness and comfort.

The modern manger is intended to hold hay, corn, and water; the whole length of the manger is six feet, so if these three are put into that space, the design must be something different from the manger intended for hay and corn only, and it is principally on this difference that most of the variations in design are based.

Another explanation of varieties of pattern exists in the fact that mangers are not unfrequently a source of injury,

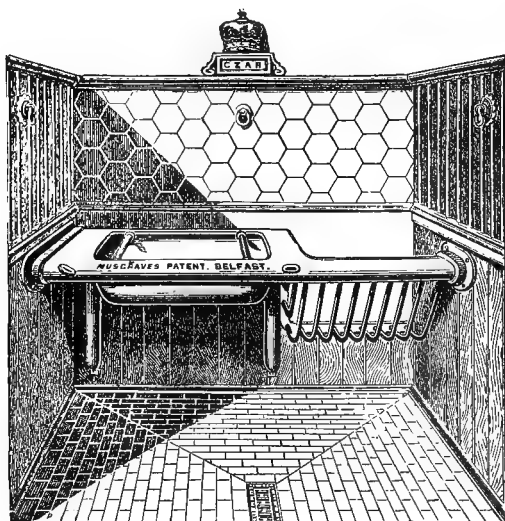

Fig. 109.—Manger and hay-rack, the former provided with roller guards.

and great care has been taken in the production of harmless manger fittings.

A manger for a stall is not quite the same as one for a box, as the additional space of the box with its corners allows of something less bulky being produced, and the corners are utilized for the purpose (Fig. 108).

A manger should be large enough to contain the grain ration, if too small it frequently gets thrown out. To prevent this waste roller guards are sometimes employed (Fig. 109). The manger need not be too deep and should be capable of being cleaned out, there should not be any



incurved lip to the top plate to conceal food and harbour dirt. The material of which the pan of the manger is composed should be enamelled iron.

The hay rack should never be over head, it is an unnatural position considering that horses were intended to feed off the ground, and is a frequent source of injury to the face and particularly the eyes.

The hay rack is sometimes fitted with a hay guard to prevent waste (Figs. 110 and 111), the guard being a sort

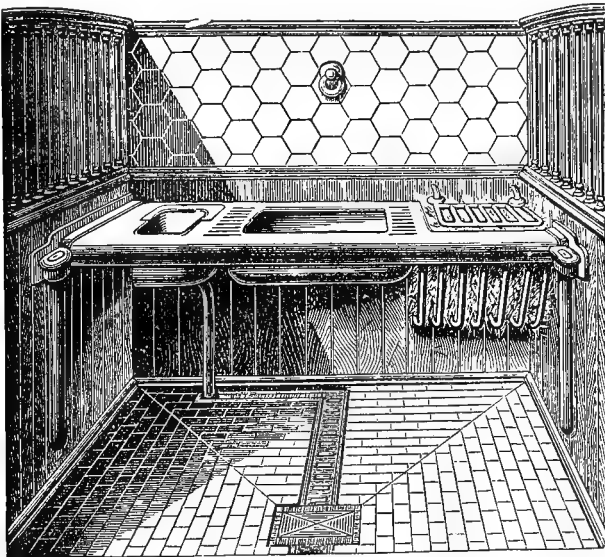

Fig. 110.—Manger with sliding hay-guard and Water Vessel (Musgrave).

of grid which covers the hay, and either works by sliding down on the hay, or the latter is pressed up from below. The object of this contrivance is to prevent the hay being thrown out of the rack, a trick that some horses soon learn and never forget.

The presence of a water vessel in the manger is most desirable from a dietetic point of view, a horse that always has water before him is less liable to colic, and moreover is fitter and better, as there is less chance of being kept short

of water. We say less chance, for the reason that the vessel is not self filling and very often labour saving contrivances encourage neglect.

The water vessel is filled from a tap which is placed out of harm's way; it is emptied either by being turned over or by a plug. Whichever method is adopted the outlet pipe should not open into the stable drain, as is always so arranged, but carried through the wall and open over a gutter outside.

The height of a manger from the ground depends upon the height of the horse; it is generally fixed at 3 feet 3 inches to 3 feet 6 inches above the floor level.

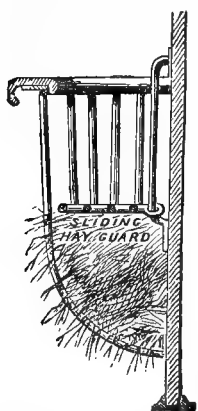

Fig. 111.—Section of sliding hay-guard seen in Fig. 110 (Musgrave).

The front is frequently boarded in to prevent the horse from getting its head beneath, but this is insanitary, as it harbours dirt, etc., and the space beneath the manger cannot be cleaned out. The manger fittings should either be as in Figs. 109 and 110, or should slope away from front to rear, the object being to prevent the horse from bumping his knees when feeding, a common habit with a nervous or greedy feeder. This design is seen in Fig. 112.

Whatever pattern is adopted every part must be rounded, with no projection nuts, bolts, or screws, or the animal is certain to injure itself.

The mangers in the loose boxes are much less liable to cause injury, they are frequently triangular so as to fit in one of the corners; hay can be kept in one, corn in another and a third used for water. Fig. 108 shows a type of loose box manging. The general principles observed are those laid down in stall manging.

The *Tying or Fastening* arrangement for horses is always a difficult matter; it must be strong and at the same time something which will produce no injury. There are probably more accidents from fastening arrangements than from any

other cause, exclusive of kicking. It is inconceivable at times how horses manage to get into difficulties, the most common one, of course, being a fore or sometimes a hind leg over the collar shank.

Whatever method is used to secure the head whether rope, leather, or chain, there must be a counterpoise at

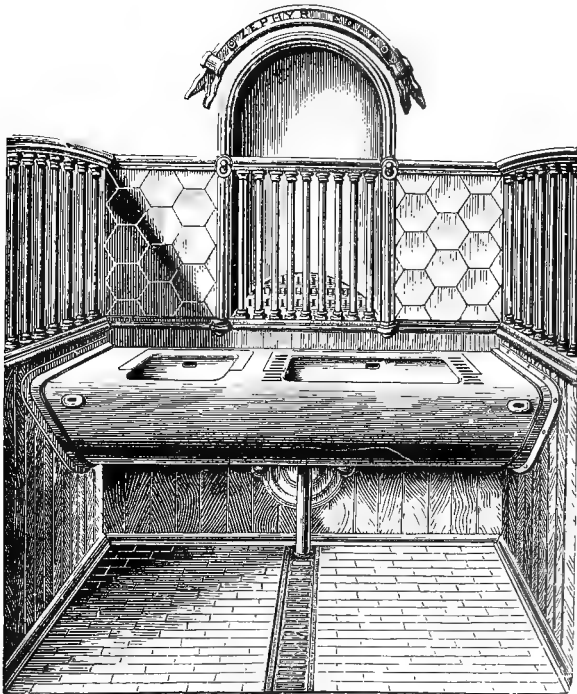

Fig. 112.—Manger fittings, with hay-rack let into the wall and manger sloping away from the knees (Musgrave).

the other end so that the collar shank is never slack; no horse can get a leg over one that is taut.

Great ingenuity has been shown in devising methods of fastening. Some are seen in Figs. 113 to 116, and all of these are safe, and what is not unimportant are noiseless. Most tying arrangements are attached directly or indirectly to the manger, so that the latter must be securely fitted as

a great strain is imposed on it when a horse suddenly runs back from fright, and they have been known to be pulled down from this cause. Sometimes the tying arrangement is double one on either side, and with certain horses this is necessary. See Figs. 109, 110 and 112.

We shall have later to refer to the question of stable injuries and how they may be prevented, but it is permissible here to say that the majority are under control, and many of them depend upon the length of the collar chain or shank.

A long head rope, collar chain or shank—whatever name

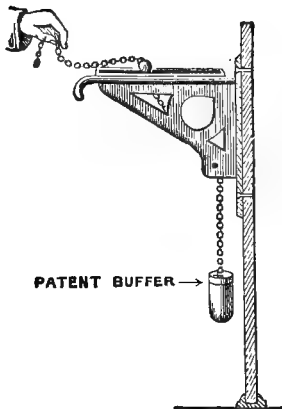

Fig. 113.—Noiseless fastening (Musgrave).

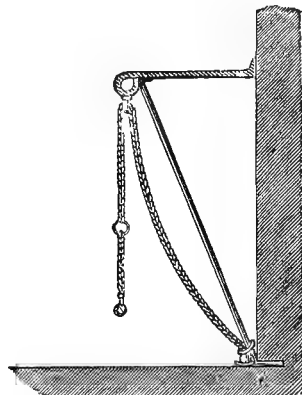

Fig. 114.—Sliding ring on bar (St. Pancras).

it may be known by—enables a horse to hang back in the stall and kick his neighbour or get kicked; it enables him to get his fore or hind legs over the head collar fastening, it admits of him trying to get at his neighbour with his mouth over the stall partition, with the result that a kicking competition frequently ensues. In a word, it enables the young, idle, overfed horse to get into mischief, and horseplay always results in injury.

The length of a head collar fastening is ascertained in the following way:—Measure the height from the ground to the top plate of the manger, add about eight inches to

it, and that length, and no more, is required by the horse. In other words, the collar shank should be sufficiently long to allow him to lie down freely; any length over and above that is not only unnecessary but harmful.

Fastenings in loose boxes are required, though if frequently used they destroy the value of a box, but there must be some way of securing a horse's head when he is being dressed, or when the door has to be left open for the box to be cleaned out.

The simplest method for a box, and one which is quite

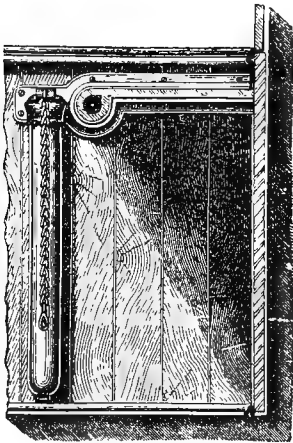

Fig. 115.—Noiseless fastening (Musgrave) for placing either under the manger or against the side of the stall, depending upon whether a single or double fastening is adopted.

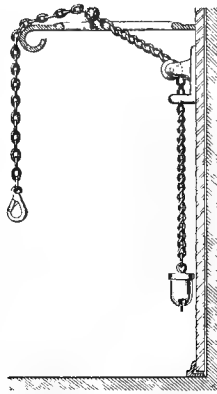

Fig. 116.—Collar Chain, with Spring Hook and Counterpoise.

free from any risk, is a bar a few feet in length, depending on the size of the box, and fitted close against the wall between the two corner mangers; on the bar slides a runner to which the horse is secured. This admits of the animal getting either to the hay or corn; the arrangement is seen in Fig. 108.

*Middle Class Stables.\**

These are of many varieties and types. They differ in one respect from high class stables, in the fact that the owners are poorer men and keep fewer horses; the fittings of the stables are not elaborate but plain and, if modern, substantial, while in old stables of this class both the fittings and sanitary arrangements may offend every cardinal principle laid down.

When constructed on hygienic principles, the difference between upper and middle class stables is mainly one of cost. The horses require the same amount of air and light, the same impervious paving; but the walls need not be tiled; cemented half way up and colour wash will meet all necessities, while the fittings though substantial and strong, require no decorative art or costly finish.

The drainage, a point we have yet to discuss, may also be rendered much cheaper and infinitely more sanitary by being surface, a condition which in high class stables would only be tolerated in a modified and expensive form.

The windows need not possess any elaborate finish, the frames may be plain but the Sheringham type must be maintained, worked, as in the cheaper windows, by a cord and roller.

The doors may be perfectly plain without panelling or beading, the only necessary requirements are height and width.

The mangers may be without the water vessel, simple and strong, but the other conditions must be fulfilled.

The area of the boxes and stalls remains quite unaffected.

*Industrial Stables.*

There is no intention to describe the varieties of these which exist, they range from the often well conceived stables of public companies, to the hovel of the small cab

\* There are no measurements given in this section, where they are required reference should be made to the foregoing.

proprietor or petty tradesman, whose means can afford no comforts, and whose ideal does not rise to cleanliness.

Nothing useful would be gained by a description of these places in our towns and cities, they are a disgrace to our civilization, but they will exist so long as the law permits. There is no attempt at any kind of sanitation, the animals are overcrowded, frequently two in a stall; there is an absence of light and air, and the presence of stench from fæcal and other excreta; the floors are porous, broken, containing puddles of urine and saturated with filth; the air is ammoniacal, and wretchedness predominates.

Such places are found in crowded courts, side by side with human habitations, in busy streets, in cab yards, in the back premises of the small tradesmen, and even in places where the surroundings might reasonably be expected to give better results.

We can do nothing with such places, the only thing is to sweep them away, though we fully realize the enormous value of the property we would thus ruthlessly destroy.

What we intend to do in this section is to describe how horses belonging to the industrial class should be housed, it refers to the large proprietor, it makes no reference to the small owner whose means and inclinations do not lie in the direction of improvement, and whose landlord cannot be touched by law. Some day the State will be compelled to step in and prevent men breeding disease amongst their animals to the common danger of the public, but that time is not yet at hand.

When ground space is limited and the number of horses to be accommodated numerous, it is quite possible stables two or three stories high may have to be built; but the cardinal principle is that they should have an open roof, which under the above circumstances is obviously impossible. Regarding stables built in stories, it can only be said that as far as possible they should in other ways follow the general conditions to be laid down for model industrial stables.

The number of horses to be provided for may be in tens

or hundreds, we shall as a matter of convenience take a unit stable for 48 horses, and what applies to this will apply to any larger or smaller number.

*Type of Stable.*—Fig. 117 shows the ground-plan of such a stable, it is arranged for the horses to be in groups of twelve, with their heads to the outside wall and a passage down the centre; doors are placed at each end and in the middle, and a window over the head of each horse.

The object of this is to obtain the two important conditions of air and light, with effective ventilation, and the latter is finally secured by the ridge of the roof being open and protected by a louvre. If required extra light may be admitted through the roof below the ridge.

On these points it will be well to refer to the chapter dealing with ventilation, as no further mention can here be made.

Where more than one block of stabling is required the greatest care must be paid to avoid overcrowding and getting the blocks too close together. The nearest that one block should be to the other is twice the height of the building; but if space permits the great thing is to open out, and let the air get well in between the blocks.

Good and bad block plans are shown in Figs. 118 and 119. For a large number of horses anything which approaches a square is objectionable, especially when built on a limited area. Blocks may be arranged in a parallel group as in Fig. 120, which is known as the Pavilion system. In this figure stabling is provided for 480 horses with forge, forage stores, shelter for vehicles and offices; the proper relative positions of these is also assigned.

With a smaller group of buildings there is less objection to departing from the ideal block plan, as there is less risk of overcrowding.

The internal fittings of industrial stables are strong and plain, we will consider them in much the same order as in the other class of stable.

*Stall Division.*—These are almost invariably swing bails suspended from the manger in front and a heel post or the



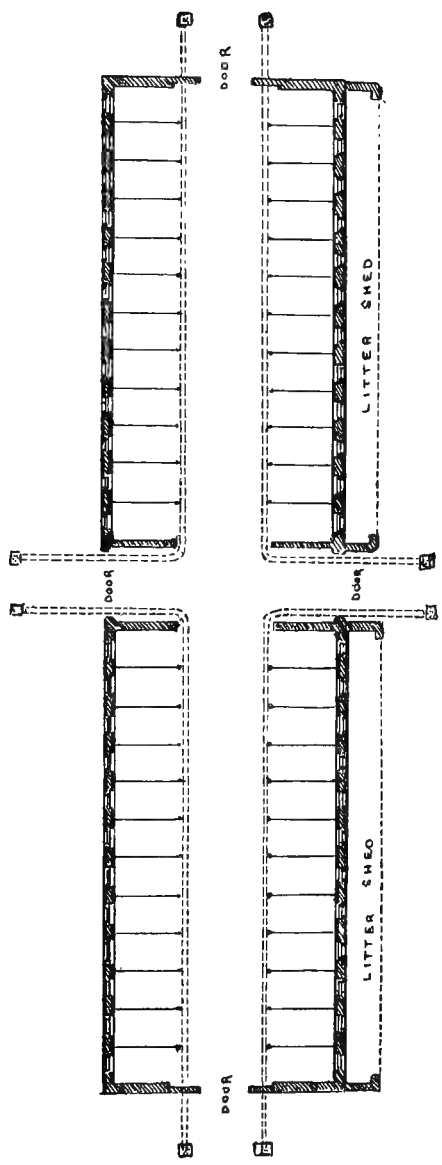

Fig. 117.—Ground-plan of Industrial Stable for forty-eight horses.

roof behind. Sometimes bails are made of iron, as in the army (Fig. 121), but they are preferably made of wood.

The essential of a good bail is that it must be deep

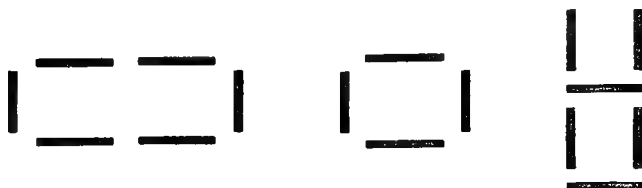

Fig. 118.—Bad Block Plans.

enough to prevent a horse kicking under it, and high enough to prevent kicking over it.

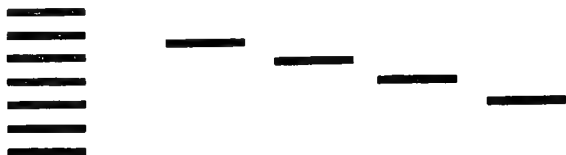

Fig. 119.—Good Block Plans.

The most common accident in stables with bails is horses getting over them in the night, and in consequence sustain-

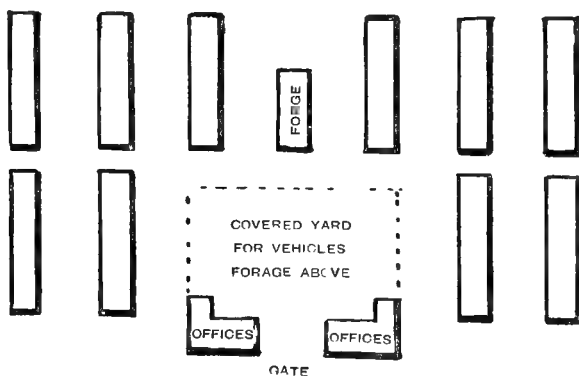

Fig. 120.—Pavilion system of stables for 480 horses.

ing severe injury. Considerable ingenuity has been expended in devising methods for releasing the bail when a

horse meets with this accident, yet if the bails were fitted higher no such methods would be required, for the animal could not kick over them.

It is no use talking of fitting higher a bail consisting of a simple pole either of wood or iron, for the higher this is

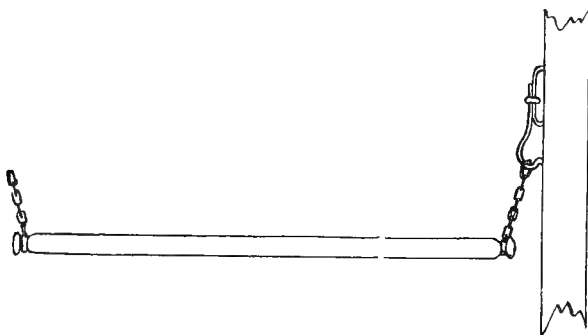

Fig. 121.—Army bail made of iron.

lifted the more useless it becomes as a protection. In fact, we may at once say that for a determined kicker it is useless, and against a moderate kicker insufficient.

An excellent bail hook is seen in Fig. 122; it is at once released by raising the link. No hook should be used for a bail support that is not completely protected, or most serious wounds may be inflicted.

Bails may be described as simple, viz., if only a pole or plank; compound if consisting of plank and kicking piece; deep, if made in one piece to be hung high and drop low. Each of these must be considered separately.

The *Simple Bail* (Fig. 121), as above described, is hardly used anywhere else than in the army, where it is an iron pole suspended from the manger in front and heel post behind. To the latter it is attached by several links of chain which pass over a swivel hook, from which it is at once liberated in the event of an accident. The objection to this form of bail is the



Fig. 122.—Bail hook which is released by pulling up the link.

insufficient nature of the protection afforded, with the result that kicks and injuries are innumerable.

A better form of simple bail is that seen in Fig. 123. It



Fig. 123.—Simple plank bail, either suspended from above or from a heel post.

is a very good protection against an ordinary kicker if fitted low.

A *Compound Bail* (Fig. 124) may consist of a pole or a plank, with a kicking piece attached. Sometimes the kicking piece is carried the whole length of the bail which is unnecessary, for the kicking obviously occurs behind and not in front. It is quite sufficient if the kicking piece

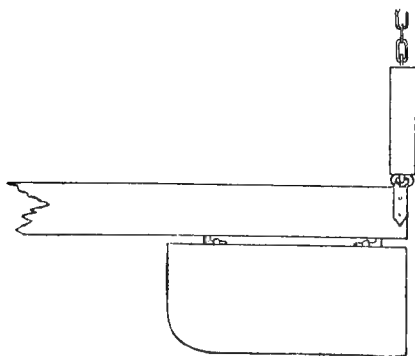

Fig. 124.—A compound bail with kicking-piece attached.

occupies half the length of the bail. It requires to be made of at least 2 inch wood, and should be attached to the bail itself by a form of hinge; but whatever method is

adopted there must be as little interval as possible between the bail and the kicking piece. If the space is considerable, as is frequently the case, there is a risk of the foot getting fixed, which would be disastrous.

A *Deep Bail* (Fig. 125) is very nearly a swinging stall partition, it is especially valuable for heavy horses, and if properly secured above is an absolute protection against kicking; it is of course very heavy. One of the difficulties in stable fittings of the class we are now describing, is to convey to those responsible for construction how solidly they should be built. They have no conception of the force a horse can exert when kicking, and will put in half inch

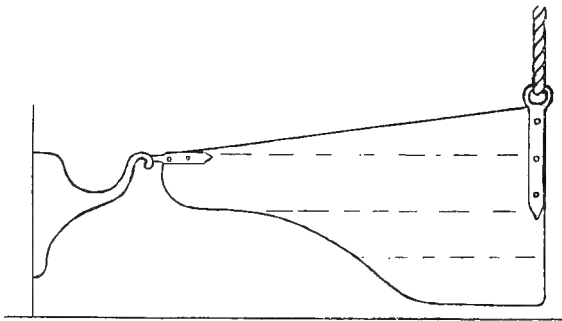

Fig. 125.—A deep bail.

and inch boards for kicking pieces; they might just as well use match boarding.

There are some that advocate hanging the bail low, for the reason that if the horse kicks over it he can get back again. If a simple pole bail be employed, it is far better to place it close to the ground where it may be of some service, than high up where it is very little protection and dangerous.

It is important to bear in mind that if bails are intelligently made and fitted to a stable, they give as much protection against kicking as a fixed stall partition, whereas if the requirements of horses are not understood a stable with bails is one with injuries.

A careful inspection of the figures is essential to a clear understanding of the subject, which is one of the most important in connection with the fittings of industrial stables.

There is a difference of opinion whether bails should be suspended from above, or to a post behind. The argument in favour of a post is greater security of attachment, and the fact that the post may be made to hold the harness. The disadvantage of a post is that it frequently causes horses to kick; a bail fixed to a post has much less lateral play than one attached from above. One of the objects of bails is to have a yielding partition when a horse is turned round in its stall.

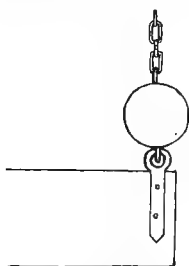

Fig. 126.—Ball to prevent injury from the chain or rope, when the horse kicks over the bail.

For light swing bails there is no reason why they should not be attached above, but perhaps a post is essential for the heavier ones.

When a horse gets over the bail, he generally succeeds in removing strips of skin from the coronet to the groin, and if close on the rope or chain, this inflicts a certain amount of injury on the perineum during the struggles. To prevent this a cylinder of wood or wooden ball is frequently placed over the rope as indicated in Figs. 124 and 126.

There are other methods of liberating bails than that shown in Fig. 122, several being worked on the principle of a spring hook which opens at a pressure of about two hundred pounds. All these are satisfactory when first fitted, but through constant use or defective material soon get out of order, so that the bail falls with very little provocation, or else fails to release itself. There is nothing more effective than the hook seen in Fig. 122, which at once opens on pulling up the link.

From a sanitary point of view bails are superior to fixed stall divisions, as they interfere less with the free circulation of air.

The *Mangers* for industrial stables are of the simplest kind and strongly made. They consist of one long pan with two bars or guards across to prevent the food being thrown out, there is no hay rack as all the hay is chaffed (Fig. 127). It is best to have the manger pan of galvanized iron or enamelled iron, and capable of lifting out so that it can be easily cleaned or disinfected if necessary (Fig. 128). Sometimes the manger pan is made shorter but moderately deep and semicircular below; this possesses certain advantages, for the throwing out of food, a common trick, is rendered more difficult.

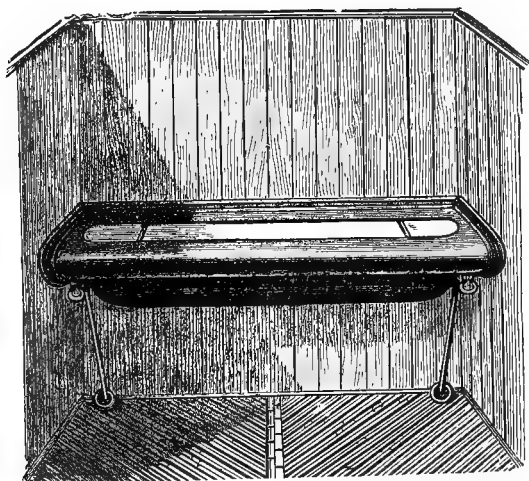

Fig. 127.—Manger for industrial stable; shows also method of tying, viz., a sliding ring on a bar placed on either side (St. Pancras).

*Method of Tying.*—The tying up arrangement is frequently a strong ring attached to the manger, through which a rope or chain passes to the head collar. It should have a good log of iron on the end of it, if a chain is used, so as to act as a counterpoise. If a rope is employed a wooden log is sufficient. The length should be as previously mentioned on p. 304.

In all stables of this class, especially with heavy horses, a double attachment is desirable from a ring on either side

of the manger. This double attachment is not only for greater security, but to ensure the horse lies in the middle of his stall and not with his head under the bail in his neighbour's ground (Fig. 127).

This is a very important point in stables with bails; the position horses get into at night, can only be realized by a visit to the stable during the early hours of the morning.

With a long collar chain they are lying under the bail,

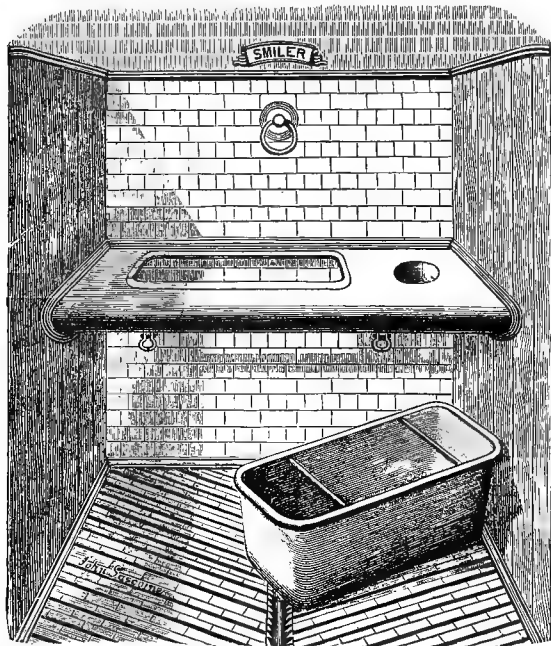

Fig. 128.—Removable manger pan (St. Pancras).

or even in the gutter behind the stalls, with their quarters in the passage. As previously mentioned the most prolific source of injury to all horses in stables is a long head rope or head chain.

The bail in Fig. 125 it will be observed is cut away in front. If this were not done there is no other alternative with this deep bail but to carry it close to the ground, in order to prevent the horse getting his head and neck fixed



under it when lying down. It is made deep behind and hangs close to the ground for the sole reason of preventing the animal getting his hind quarters under it, and having perhaps a difficulty in rising. All this can, however, be prevented by collar chains or head ropes of proper length.

Another excellent means of tying up horses in bailed stables is that shown in Fig. 114, viz., a sliding ring on a vertical bar. With this contrivance it is impossible for the head chain to be left too long, and such a chain is correctly fitted when, with the horse's head over the manger, it is sufficiently long to enable him to raise it to its natural height.

The stalls in a bailed stable can be reduced to 5 feet 6 inches wide, excepting for big horses, where they should not be less than 6 feet 6 inches; while the length from manger to heel post, or to the end of the bail, as the case may be, should not be less than 10 feet.

The *Drainage* of these stables should be of the simplest and most effective kind, viz., surface, for a full account of which the chapter on drainage must be consulted.

The *Doors* for a large stable should be sliding and in two halves longitudinally divided, each half should be four feet wide, giving an opening of eight feet when both are pushed back. There should also be doors at the middle of the stable on either side of the building, and a door at the opposite end. The end door should be sliding, the side door owing to the stalls will have to open inwards. Doors are a powerful means of drying the floor and flushing out the stable with air when the horses are at work.

Up the centre of the stable should be a passage about 10 feet in width.

*Litter Shed.*—Outside the stable protected by a veranda should be litter shed, where the bedding can be placed during the day instead of leaving it in the stable.

## BUILDINGS FOR CATTLE.

The class of building we have hitherto dealt with is that mainly in towns and cities, we have now to examine those in the country which are designed for the use of animals, and in connection with this we have to consider the question of the farm homestead, and to devote attention more particularly to the housing of cattle, rather than horses, which subject may be considered as previously dealt with.

The selection of the site for a homestead is governed by several considerations. It should if possible be centrally situated on the farm, yet the proximity to a good road or a railway station are points too important to overlook. In respect of site, aspect, soil, and facilities for drainage, the conditions do not differ from those previously laid down.

A good dry soil, elevated position, if possible sheltered from the coldest winds, with good and sufficient water-supply, are all points to take advantage of. The type of building depends entirely upon the system of farming which is to be adopted, for it is obvious that the accommodation required on a purely dairy farm will differ from that which is devoted to the fattening of cattle and cultivation of food for their consumption, while a mixed farm—which represents the one most commonly in use—will combine portions of both the others and be correspondingly larger in extent.

It is not our intention to deal with the farmhouse, granaries, barns, convenience for implements, steam power, and the dozen other essentials required for a mixed farm which is up-to-date, but to confine ourselves entirely to a consideration of the sanitary arrangement of farms and buildings for animals of all classes.

The general arrangement of the buildings are based, in all but dairy farms, on two important considerations, viz., the facilities for feeding the animals, and the collection of manure.

The labour of feeding must be reduced to a minimum, and the arrangement of buildings is such that from the time the food enters the farm until it leaves it as manure, the sequence of events shall be permitted to take place in their proper order, so as to save labour as far as possible.

For example, the rooms where the food is prepared are placed near to the barn and granary, and communication between these and the cattle-houses is complete and uninterrupted, in fact upon the correct placing of these the whole convenience of the farm depends.

With a purely dairy farm the primary consideration is the storage of milk, and the proper carrying out of this is a matter of the first consideration, though even here facilities for storing, preparing and distributing the food to the cows can by no means be lost sight of.

The above points which are of paramount importance to the farmer, necessitate his buildings arranging themselves either on three or four sides of a square, a formation to which we have offered the greatest objection in the case of habitation for horses, but which appears difficult to overcome in the case of cattle owing to the question of labour. Nor is there, perhaps, the same strong objection to this formation in the country, where the place can be made freely open to the purifying influence of air and sunlight.

A *Dairy Farm* must contain the buildings for a dairy proper, which is quite distinct and cut off from any other buildings on the farm. The site of this should be as far as convenient from the cow byres, and as far as possible from the piggeries and sewage receptacle.

The *Dairy* consists of certain rooms where the milk is set for cream and butter made. This structure has nothing to do with the veterinary hygienist, its sanitary aspect belongs to the medical authorities, but it is permissible to note as a matter of general interest, that the points aimed at in the dairy are: (1) An equable temperature which is secured by the windows facing north, and both they, the walls, and ceiling being double. (2) By the place being absolutely free from dampness, which is ensured by the double wall and a

concrete layer under the tiled floor. (3) Scrupulous cleanliness, which depends upon the facilities for excluding dust, the shape and character of the shelves, and the personal equation of the attendants.

Close to but quite distinct from the dairy buildings is the cow-shed, byre, or shippon, the size of which depends upon the number of cows to be accommodated.

#### *Cow-houses.*

The cow-shed should conform in general structure to the buildings described for horses. The walls must be dry, plastered for at least half their height, and white-washed throughout.

*Lighting.*—The lighting must be complete, the dark cowshed of days gone by can no longer be permitted. Without good lighting it is impossible to carefully inspect the cows, equally impossible to see that sanitation is carried out, and that the cows are clean especially as regards their udders.

This lighting may be from above, or both from above and by means of windows. We advocate both, the windows are required for ventilation as well as lighting, and lighting from above, which is recommended by some, does not necessarily facilitate ventilation.

*Ventilation.*—The requirements of the cow in fresh air are theoretically the same as a horse, but we hesitate until cow-houses are artificially warmed, to recommend the same inlet area as has been recommended in the case of horses, firstly because the conditions under which the animal is living are absolutely artificial, and secondly the lowered temperature in winter would affect the output of milk. The hesitation expressed on this point need not interfere with the construction of windows, which may if necessary be double, should a large window area be in danger of reducing the temperature too low. The windows should be of the Sheringham variety, and the theoretical inlet area depends, as we have seen in the case of horses, on the velocity of the

wind, but should be capable in summer of allowing each cow one square foot of ventilating area.

Again, taking the stable as our guide, we may regard the windows as inlets and outlets, but to guard against any possible closure of outlets, roof ventilation should be established. It is quite likely the ordinary ridge and louvre ventilation might prove too much in winter, as no louvre will keep out driving snow, but the louvres can easily be placed under control, or if preferred fixed extraction cowls may be introduced.

We anticipate every objection to this scheme, but from a sanitary point of view it is correct, and if adopted we should in course of time get rid of tuberculosis. Those whose business it is to own and look after cows living under the unnatural conditions which our civilization entails, will of course disapprove entirely of either giving more air or light, but that does not affect the correctness of the above statement.\*

*Cubic Space.*—As the question of cow-house ventilation at present stands, the Local Government Board insists on a minimum cubic space for certain cows; the town or city cow being allowed 800 feet, which is a smaller cubic space than that for a sick man in a Poor Law infirmary!

When dealing with ventilation, the question of cubic space for a cow was alluded to and theoretically placed at 1,600 feet. We know perfectly well the horror this will be received with by cow proprietors, and further we recognise how greatly it adds to the cost of construction. If the chapter on Ventilation be consulted, it will be observed that the value of increased cubic space lies in the smaller number of times per hour that the air needs to be changed. Bearing this in mind, and the cost of construction, we regard the minimum cubic space for a cow at 1,000 feet. This is more than the Local Government Board requires, but the regulation as it stands at present is peculiar, it takes no notice of the

\* The Regulations of the Local Government Board prescribe that all cow-houses, whether in town or country, shall be 'sufficiently' lighted and ventilated, but it does not state what 'sufficient' is to consist of.

country cow's cubic space, but only for those cows which are not turned out to graze during the year, or not turned out during some portion of the day. We will leave the Local Government Board to explain its own case.

*Circular Letter of Local Government Board to Councils of Boroughs and Urban Districts, March 11, 1889.*

'It will be observed that No. 8 of the Regulations (Model Regulations issued by the Local Government Board; see below), which deals with the question of air space in cowsheds, does not apply to cowsheds the cows from which are habitually grazed on grass land during the greater part of the year, and when not so grazed, are habitually turned out during a portion of each day, and it is obvious that a regulation on this subject which might be adapted to cowsheds in towns, where the cows are kept and fed within the building, might be unsuitable for cowsheds in the country, where the cows are regularly grazed on grass land during the greater part of the year, and are during the rest of the year usually turned out for a portion of each day.

'The Royal Commission, in their recommendations, drew a distinction between the rules which should be observed on this subject as regards cowsheds situated in populous and those situated in non-populous places, but no indication was given as to the means by which this distinction was to be made. It is clear it could not be accomplished by any test of population or by adopting the geographical limits of urban and rural districts, without creating anomalies which would be indefensible.

'Neither is it easy to see how the distinction can be carried out except upon the plan suggested by the Board, which seeks to give effect to the chief difference between cowsheds in towns and cowsheds in the country, or, in other words, between the case of cows which are kept entirely or as a rule indoors, and that of cows which are usually turned out to graze.

'It will be noticed that No. 4 of the Model Regulations, which provides that every cowkeeper must cause every cowshed in his occupation to be sufficiently ventilated, and for this purpose to be provided with a sufficient number of openings into the external air to keep the air in the cowshed in a wholesome condition, applies to both classes of cases.'

*Extract of Order No. 8, Model Regulations of Local Government Board—Dairies, Cow-sheds, and Milk-shops.*

No. 8. 'A cowkeeper shall not cause or allow any cowshed in his occupation to be occupied by a larger number of cows than will leave not less than *eight hundred feet* of air space for each cow.

Provided as follows :

‘(a) In calculating the air space for the purposes of this regulation, no more space shall be reckoned which is more than *sixteen feet* above the floor ; but if the roof or ceiling is inclined, then the mean height of the same above the floor may be taken as the height thereof for the purpose of this regulation.

‘(b) This regulation shall not apply to any cowshed, constructed and used before the date of these regulations coming into effect, until two years after that date.’

It has been found necessary to make these extracts in order to explain the position. The Act of Parliament upon which the Dairies, Cow-sheds and Milk-shops Order is based makes no mention of cubic space. Even the Order itself in Section 13, which gave local authorities power to make regulations regarding cowsheds, makes no mention of cubic space, and it required a judicial opinion to settle the point that local authorities had such power.

The amount of this cubic space is not mentioned anywhere but in the above quoted Model Regulations, which are not official, and Sir Ernest Clarke, after a careful examination of them, has pointed out that the ‘Models’ have no more real authority than that of the printers who sell them!\* The general feeling among cow proprietors and landlords is that the cubic space laid down is excessive; with this we do not for one moment agree, but it is interesting to know the regulation cannot be enforced.

*Superficial Area.*—We repeat the minimum cubic space for a cow should be 1,000 feet; unfortunately very little of this can be allotted to the ground on which she is actually standing, as the universal prejudice is in favour of a narrow stall, often only three feet in width, occasionally three and a half feet, allowing a superficial area of from 21 to 24½ feet of standing room. Of course by including the share of the passages the total superficial area is raised, but it is seldom as much as 70 feet.

\* ‘Air Space in Dairies and Cow-Sheds’: *Journal of the Royal Agricultural Society*, vol. viii., No. 4, 1897.

The object of a narrow stall is to ensure the whole of the urine and fæces being passed into the drain behind; this is done not in order that the cow may be kept clean, but that no manure may be lost. We have touched on this question before, and it is evident from what was then said that anything which is calculated to cause a loss of manure will not meet with acceptance. Still we consider the minimum actual standing space should not be less than 22 feet, that is to say, the actual stall not including the manger should measure  $5\frac{1}{2}$  feet in length and 4 feet in breadth clear inside measurement.\* Almost invariably there are two cows in each stall, a proceeding which, though sanctioned by custom, cannot be regarded as a hygienic proceeding. Each cow for its own comfort and on sanitary grounds should have a separate stall.

We are perfectly aware in making this suggestion it will not meet with the approval of owners; to them it means expense, for their accommodation will require to be increased. At one time the State placed its soldiers two in a bed, but the overcrowding killed them off with tuberculosis, and it was found economical to accommodate them more liberally. But there is another aspect to the cow question—viz., that of cruelty. The country cow spends six months of its life, and the city cow still longer, standing on a space  $5\frac{1}{2}$  feet by 3 feet, utterly unable to move from side to side, backwards or forwards, and dependent entirely on the good-nature of her neighbour for rest. Add to this that many, certainly those in Scotland, get no bedding, and the lot of the cow cannot be regarded as an enviable one.

*Cattle Stalls.*—The stocks (they can hardly be called stalls) in which cows are kept for so many weary months of their life, are devised with the object of saving the whole of the solid and liquid manure, and it is a very proper question to ask how this loss can be avoided if a larger superficial area be given to the cow? If a cow be given 4 feet in width and  $5\frac{1}{2}$  feet in length, exclusive of the manger,

\* The Local Government Board takes no notice of superficial space in cow-sheds.







Fig. 129.—Iron Fittings for Cow-sheds (Musgrave).

To *live*, p. 325.

and is tied up by a short attachment in the centre of the stall, and not to one side as at present, the whole of her excreta can be secured by two surface channels behind the standing, one on which the fæces fall being two feet in width, while a urine channel one foot wide runs side by side with the channel for the fæces, and collects the whole of the fluid excreta. This matter will be dealt with presently, and again in the chapter dealing with drainage.

Every cow should have her own stall, and not be compelled to breathe the expired air of her neighbour.\*

The stall fittings should be iron, as being not only more sanitary, but more easily and thoroughly cleaned and disinfected if required (Fig. 129).

*The Manger* should be placed a little above the ground, enamelled iron throughout, and containing at one side a vessel for water. Cows are frequently insufficiently watered, under the impression they do not require much. Every drop of the fluid part of the milk represents a loss of fluid to the body, and requires to be replaced. Water should always, if possible, be kept by them.

*Tying up Method.*—The general arrangement for tying up is a strap round the neck, with about 16 inches of chain attached to a vertical bar in the stall partition.

If a single stall be used as recommended, the method of tying up would be a ring attached to the manger, with sufficient length of chain to enable the animal to freely rise. This length of chain would not permit the hay to be taken from an overhead rack, such as is issued with some cow-house fittings; but, as in the case of horses, the hay should not be overhead, but below. Further, it should all be chopped, so that no special hay-rack is required. Stall fittings must be so arranged that in the absence of a hay-rack an animal cannot get forward in the stall. To prevent this bars should exist arranged horizon-

\* At one time cows were secured by the head in a kind of pillory, lateral movement was impossible, the only motion permitted was one up and down. With this contrivance no stall divisions were used, and the cows were packed in closely side by side.

tally, otherwise the cow will get forward in the stall and soil it with excreta, which subsequently finds its way on to the quarters and udder.

*Flooring.*—The floor of the cow-house should be of concrete covered with cement. The actual standing space of  $5\frac{1}{2}$  feet by 4 feet should be level, but behind this the floor may slope to the drain, or better still, as recommended by Lloyd, there should be a drop of 4 inches into a 2-foot channel for the reception of fæces, and another drop of 1 inch into a 1-foot channel for urine (see Fig. 131).

The standing may be made of Staffordshire brick, cement, or asphalt; wooden blocks and ordinary bricks, such as have been recommended, are absorbent and insanitary.

It is not our intention here to do more than refer to the floor, as the subject of flooring, as we have previously indicated, will be considered separately under drainage.

*Position of Stalls.*—The question of labour is a very important one on the farm, and anything which can reduce it to a minimum is desirable. The most laborious operation in connection with cattle is feeding them. Their requirements are large and bulky, and experience shows that, in order to economise time and labour in the distribution of food, a tramway system for delivering the food is necessary.

If there is a double row of stalls with heads away from the wall the tramway should run down a centre passage. If a single row of stalls the line should run between the wall, towards which the heads are turned, and the fittings. In other words, the feeding is done from the front. The question of the arrangement of the stalls in a byre is, therefore, greatly influenced by the question of the facility for distributing food. It is easier to feed two rows with their heads towards a central passage than two rows with their heads towards the outside walls.

The best form of ground-plan, where labour has to be considered, is for the cattle to look, in two rows, towards a passage running down the centre of the building (Fig. 130). This passage should not be less than 6 feet in width. Behind the cattle, between them and the wall, should be another

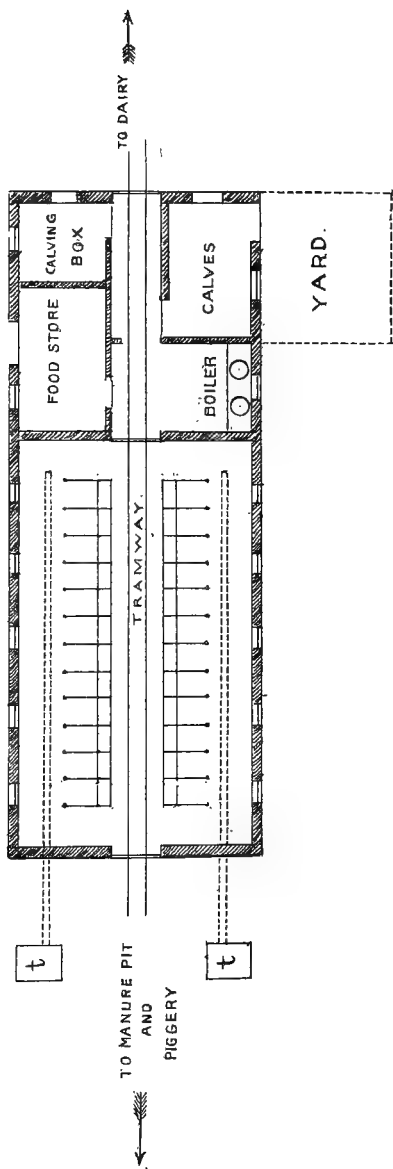

Fig. 130.—Ground-plan of Cow-shed.

passage by the side of which passes the surface channels. This passage or alley-way is used almost entirely for milking purposes; it should have a slight slope from the wall to the surface channel which runs behind the animals, so as to prevent wet lodging there when the floor is flushed.

The hygiene of the cow-house floor is of more importance than that of stables, for the reason that the place is in constant occupation; stables get several hours a day for ventilation and drying, but not so the cow-house. Both for the sake of cleanliness to the cows, and the purity of the atmosphere, the floors must be kept perfectly clean, and this can only be effected by means of water, when dealing with the semi-liquid fæces of the cow.

Taps are therefore required at convenient intervals, with a length of hose-pipe; but this matter will be dealt with under its proper section, our object at present is to draw attention to the reason for an absolutely impervious floor, and the best arrangement of the building to secure it being kept clean.

The superficial area laid down here for each cow, calculating everything, amounts to 66 square feet per head. We should have preferred making it up to 100 square feet, but have confined ourselves to the irreducible sanitary minimum. The actual area of the stall, including the manger, is 28 square feet, without the manger 22 square feet. The cubic contents depends upon the height of the building. With an open roof, 12 feet to the spring of the roof is a sanitary ideal height for a wall; but to reduce the cost of construction, the minimum height should be 10 feet, while the height of the roof angle may be taken at 6 feet.

This gives 1,056 cubic feet per head, which is the very least to be demanded, while personally we should like to see the cubic space still larger, which, of course, is obtained by greater width of building.

Mr. Lloyd, Veterinary Inspector for the City of Sheffield,\*

\* In a valuable communication dealing with 'The Model Regulations relating to Dairies, Cow-sheds, and Milk-shops,' delivered to the Lancashire Veterinary Medical Association, April, 1904.

has gone very carefully into the construction of cow-sheds. He considers that in a single byre the minimum width should be 18 feet, and he divides it as follows :

	Feet.
Feeding passage ... ..	4
Feeding trough and head divisions ... ..	2
Standing space for the cow ... ..	5.5
Channel behind the stall for fæces ... ..	2
Channel for urine ... ..	1
Passage behind the cows ... ..	3.5

These measurements and arrangement of the floor are shown in Fig. 131.

In a double byre, Lloyd recommends the minimum width should be 35 feet so as to admit of a 6-foot passage down

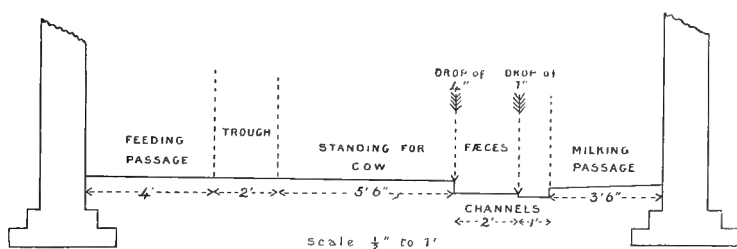

Fig. 131.—Arrangement of Cow-shed Floor as recommended by Lloyd.

the centre, the cows' heads being turned towards the outside walls and not towards the centre of the building.

The width of stall he considers should as a minimum be 3.5 feet where cows are tied in double stalls, or 4 feet when tied in single.

The superficial area per head on the above measurements in the single byre is from 63 to 72 square feet, depending on the width of stall, and rather less in the double byre. The actual standing space afforded is, of course, very much less than this, not being more than 22 square feet with the greatest width of stall allowed.

*Consideration of Existing Cow-houses.*

We must now pass from the ideal sanitary cow-shed, with its iron fittings, concrete floor, well lighted and ventilated, and deal with some of the actual buildings which exist. This was not considered a profitable study in the case of existing stables of the poor industrial type, but in the matter of cow-sheds the question is different, owing to their intimate association with the public health, and to the fact that legislative measures are possible in regard to some of them.

The poorest type of cow-shed will not detain us long. It is small, confined, closed up, unventilated; its floor is frequently pervious, or absorbent and out of repair; the fittings rough and insanitary. The walls fly-laden and filthy, and the place generally broken, patched or repaired with whatever is available; its situation is often undesirable, frequently in contact with human habitation, stables, or piggeries, and its dung-pit either under the same roof or just outside.

It is quite possible, even with a poor class of rural cow-house, to keep it clean, but such is the exception rather than the rule, while the poorer cow-houses in cities are often so situated, that cleanliness within and without is a physical impossibility.

For this reason it is recommended that no cow-sheds be permitted in crowded streets, while the compulsory closing of those where sanitary requirements are such as to be outside the range of possibility, was rightly urged by the Royal Commission appointed to inquire into the danger arising from the milk and meat of tuberculous animals.

The above Commission was greatly impressed by a visit paid to a cow-shed in a densely populated part of Edinburgh, where they found the washhouse, scullery, and stable of an ordinary dwelling house converted into a cow-shed, while the narrow court through which the air supply came was reeking with the odour of manure and decom-



posing food. Some of the animals were within a few feet of a blazing fire which was cooking their food. The same Commission visited a suburban cow-shed which was large and spacious, but rendered quite insanitary by a mountain of manure so placed as to infect the incoming air.

It has been urged that legislation for rural cow-sheds is impossible, owing to the difficulty of carrying it out; but cleanliness is not as a rule expensive, and though the building may be of the poorest type, patched, and lop-sided, yet an impervious roof and floor, lighting, and

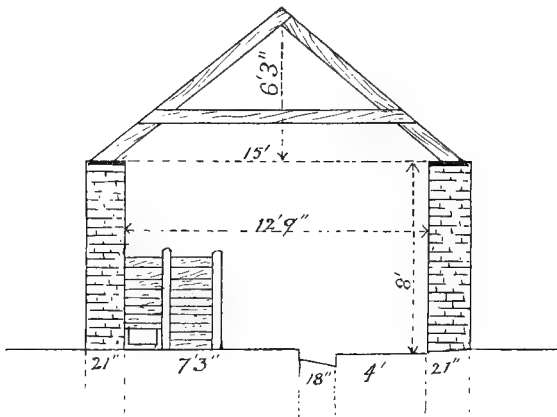

Fig. 132.—Single Byre (Henderson).

cleanliness are capable of producing great changes, and are certainly inexpensive.

The condition of cow-sheds in an important dairy district of Scotland has recently been fully described,\* and this may be taken as representing the real and not the ideal cow-shed. A study of Henderson's valuable communication will prove both instructive and interesting. Fig. 132 is a section of a single byre, the stall partition being 4 feet square, while the lateral space allotted each cow is 3 feet.

\* 'Dairy Buildings': *Transactions of the Highland and Agricultural Society*, 5th Series, vol. xi., 1899, by Mr. R. Henderson, F.H.A.S.

The cubic space allowed to a cow occupying a byre of this kind is 446·6 feet. We are told the Ayrshire County Council fixes the minimum cubic space for a cow at 375 feet, and considers a fair size for a byre is one that affords 450 cubic feet to the occupants!

Fig. 133 is described by Henderson as the more common form of shed; the cows face the outer walls with a passage down the centre. The space afforded per head is 429 cubic feet.

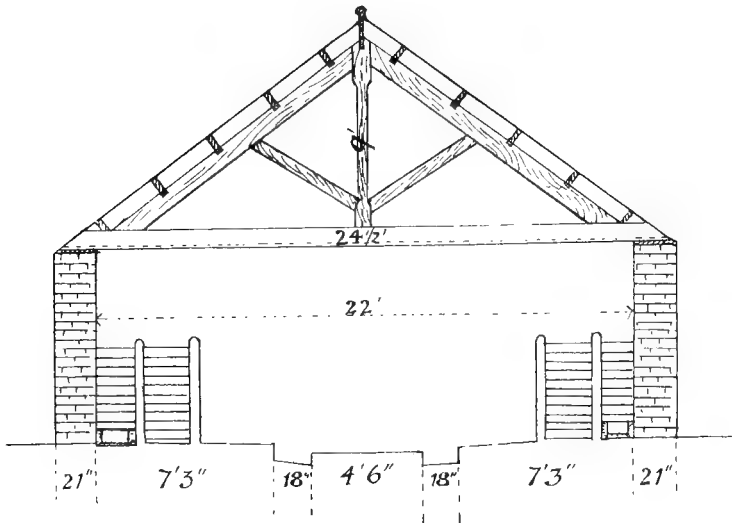

Fig. 133.—Double byre (Henderson).

Fig. 134 is regarded by Henderson as the best and is also the most expensive; it affords 578 cubic feet per head.

The ventilation in all these buildings is whatever may find its way through such windows and doors as exist, while the outlet is an opening in the ridge of the roof, which is common to this part of Scotland.

Henderson proposes to light his cow-house from the roof and not from windows; for the purpose of inlet ventilation he introduces pipes 6 inches in diameter in the wall close to the level of the wall head, and controls the amount of air these admit by means of a piece of wood so arranged

on a pivot as to cover them partly or completely. In the ridge he places a fixed extraction cowl.

For byres arranged as in Figs. 132 and 133 he introduces a 3-inch pipe through the wall for each stall, and to prevent the air driving directly on the cattle, covers the mouth of the tube with a metal box, so arranged as to break the current of air and divert it.

Henderson's views represent what will possibly be regarded as the acceptable compromise between the ideal and

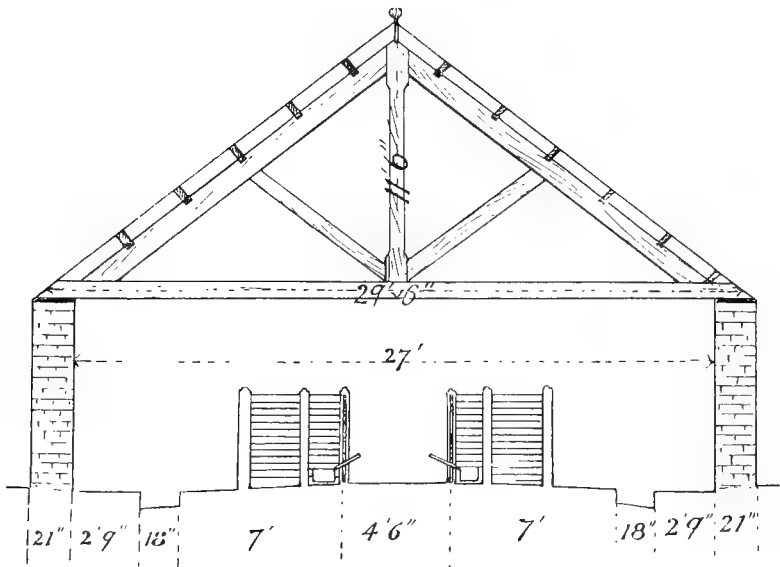

Fig. 134.—Double byre (Henderson).

the real ; he endeavours to utilize existing buildings, and to place their ventilation on some sort of definite basis ; he works with cheap material, wood instead of iron, but is fully alive to sanitary requirements, in spite of the fact that the cubic space he recommends falls far short of what is believed to be necessary.

Lloyd recommends as ventilating means for existing cow-houses, a series of iron gratings 9 inches square placed in the outside walls 6 feet above the floor level ; these are

uniformly distributed around the building. When he deals with a closed roof he places another series of ventilators high up on the wall to act as outlets, but with an open roof he uses louvred air-shafts.

Fig. 135, taken from Lloyd's communication, shows a badly-arranged and insanitary cow-shed. Fig. 136 shows the same buildings rearranged and placed on a sanitary footing.

What we have been endeavouring to do in connection with this question is to legislate for the future, to state what ought to exist, and what must come in course of time as people become better educated in sanitary matters, and more especially when the law steps in to enforce it.

We may now pass to a consideration of the calf-house, where the young stock are placed practically as soon as born.

#### *Calf-House.*

The size of this must depend upon the number of calves kept, in a purely dairy farm very few would be on hand for any length of time, unless, of course, the farmer breeds his own dairy stock, which he is strongly recommended to do.

The calf-house should be as far as convenient from the byre, as the cows are often disturbed and withhold their milk through the persistent crying of the young animal. It should consist of pens opening into a yard, each pen being provided with a manger, parallel to which is a feeding passage (Fig. 137).

Gillespie contributes a most valuable paper\* on the rearing of calves, in which he deals with the housing of the latter on the pen and yard system, which he adopted from information furnished him by Mr. Gilbert Murray, an authority in Derbyshire. This gentleman condemns the dark, undrained, ill-ventilated place generally relegated to calves, and dwells on the importance of placing the young animals under sanitary conditions, if for no other reason

\* 'Calf Rearing': *Transactions of the Highland and Agricultural Society*, 5th Series, vol. ii, 1890, by Rev. John Gillespie.

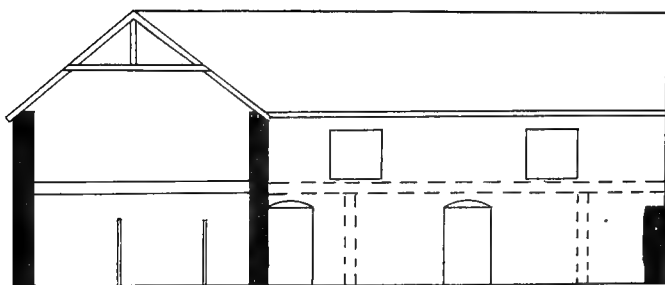
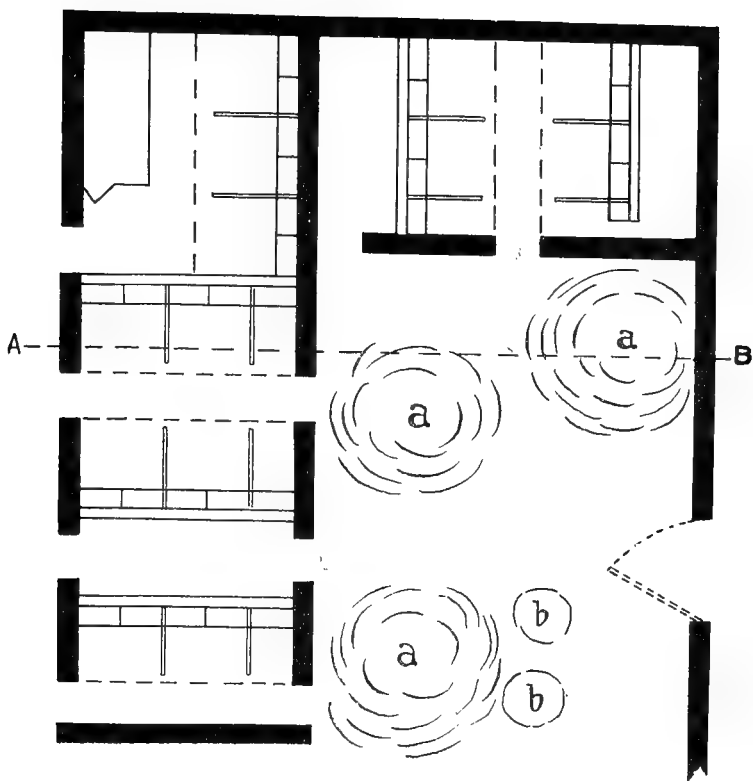

Section A.B

Fig. 135.—Ground-plan and Section of an Insanitary and badly-arranged Cow-house. It is overcrowded; lighting and ventilation are absent; the roof is low, as may be seen from the section A B, while in the yard the manure *a, a, a* is deposited anywhere (Lloyd).

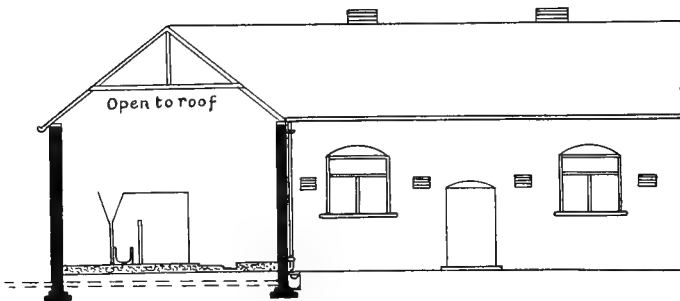
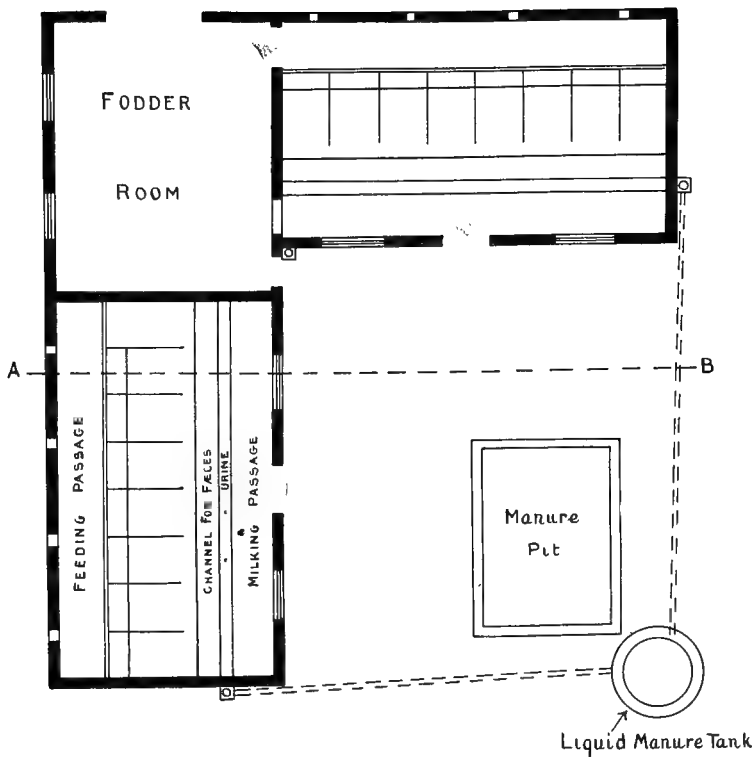

Section A.B.

Fig. 136.—The same Cow-house shown in Fig. 135, but now remodelled so that it is converted into a sanitary and convenient building. Accommodation is only provided for half the number of animals, the building is lighted and ventilated, the stalls so arranged as to facilitate the latter. The roof is open (see section on A B), a fodder-room is introduced, and a manure-pit and liquid manure-tank placed in the yard (Lloyd).

Mr. Lloyd in his other figures places his manure-pit and tank completely away from the building, which is always necessary if the needful space exists. He also figures a somewhat more convenient ground-plan than the above, and places a loft over the fodder-room.

than avoiding the diarrhoea to which they are liable as the result of their filthy surroundings. Peat moss litter is recommended for their use so as to absorb the urine, while the greatest cleanliness in the surroundings is strictly enjoined. This valuable communication from the pen of a layman emphasizes in every way greater attention being paid to the hygiene of the farm.

The yard attached to the pen enables the young animals to get fresh air and exercise, both of which are essential to their future welfare: Murray's recommendations are seen in Fig. 137. It should be noted that the flooring of the pen and yard must be prepared with concrete, to prevent the ground being soiled.

If, on the other hand, the calves are intended for the

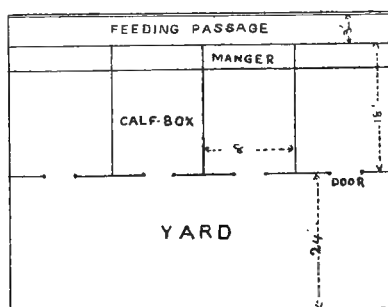

Fig. 137.—Calf-pen and yard.

butcher, they are housed if possible in separate pens which are kept dark, the whole object being to render the animal fit for food in a few weeks.

Returning to a consideration of the homestead, in addition to the calf-house there must be accommodation for yearling calves and in-calf heifers. This may be met by stalls, which appears to be a preferable system to boxes, especially for the latter.

*Bull Box.*—Accommodation may be required for a bull. This is supplied by the erection of a box which must be both well lighted and ventilated; the superficial area of this should be 14 feet by 13 feet, affording 182 square feet,

while its height should be such as to give 2,000 cubic feet of air space. The bull box should communicate with a yard stoutly enclosed, where he can take exercise.

Our consideration of a dairy farm has embraced the question of the dairy proper, the cow-house, calf-pens and bull-box. The drainage as a whole will be dealt with later, the only thing left for consideration regarding cattle is the rooms intended for the preparation of food.

#### *Food-preparing Rooms.*

If cooked food be given to cows, and we have seen previously that some authorities urge it, then arrangements should be made to accommodate the boiler or steamer in a separate compartment, so as to avoid the risk of fire and escape the moisture-laden atmosphere. To provide for the latter there must be both ridge and wall ventilation; this room by means of a tram line should communicate with the one where the food is actually prepared—viz., chaff cut, roots sliced and cake crushed; while this in turn is in direct communication with the place where the food is stored.

All these places are connected with the tram line by turn-tables placed at necessary points. No food of any kind should be kept in the byre, but the food department must be placed in communication with the cow-house through the tram line.

In a large establishment the machinery required in food preparation would be driven by steam, in smaller places by hand. With the tramway system, which has been in vogue many years, the labour of distributing the food is reduced to a minimum.

#### *Other Animals on a Dairy Farm.*

On all farms pigs are kept. They are economical, and utilize a great deal of what would otherwise be thrown away. Nowhere is this more felt than on a dairy farm where butter and cheese are made, and the separated milk



and whey available as food. Piggeries will be dealt with later, they find a place here owing to their intimate connection with economical dairy farming, and also in order to note that their position in the plan of buildings should not be too close to the byres, and under all circumstances away from the dairy proper.

Such stabling as the dairy requires must be under a separate roof, though near to the food stores, and its structure and arrangement should as far as possible be that previously described for industrial stables.

It is impossible to fix on any special type of plan for the buildings we have described, as so much depends upon the requirements and the size of operations, and further on the buildings already available, which economy dictates must be utilized.

The next form of homestead is that of a mixed farm, and here the question of providing accommodation for fattening cattle arises. Such remarks as we may make under this head are equally applicable to a farm devoted to pasture : as previously indicated, it would be without our province to deal with the general arrangement of all buildings connected with different systems of husbandry, as this is purely an agricultural question.

#### *Housing of Fattening Stock.*

The housing of fattening stock is essential during winter if full advantage is to be obtained from the food, and in various parts of the country different conditions are practised with this object. Some shut their fattening cattle up as they do their milch cows, others place them in stalls or boxes, some in open yards with shelter sheds, others in covered yards, and others combine the system of box and yard, such as are frequently found in the North of England, and known as ' Hammels.'

But the housing adopted will also depend upon the stage of fattening as well as the time of year. Animals which can be very well dealt with in an open yard with shelter

when in the store condition, may be placed in hammels or boxes as the time approaches for finishing them off.

There is still a difference of opinion regarding the advantage of stall feeding over box feeding for fattening animals, but this is a matter for agriculturists rather than sanitarians.

*Cattle Stalls.*—If stall feeding be adopted we cannot from a sanitary point of view depart from the principles previously laid down for cows. The animals must have sufficient space to lie comfortably; there is far less objection to two in a stall for fattening cattle, for their life is a short one, but the ground must be impervious, and the drainage surface reliable. The fittings employed throughout may be far cheaper than those used in an ideal dairy; for example, the stall divisions may be of wood, which, though by no means a sanitary substance to employ, may with very little care be kept clean and disinfected as necessary.

If the wood employed be 'dressed' the surface can be painted; there are paints for woodwork now obtainable which are unaffected by washing, and cleanliness is an important point to aim at. Under any circumstance that portion of the woodwork in contact with the litter should be coated with tar, and this repeated as necessary.

Bedding is allowed stall-fed fattening cattle, not in order that they may lie more comfortably, but to ensure the saving of the manure. This bedding is generally removed two or three times a week, but it is universally regarded as inferior to that obtained by the system employed in box feeding, owing to the unavoidable loss.

The plan of the stalls must depend upon the number to be fed, but heads towards a central feeding passage appears the most labour-saving system.

It is quite possible the windows considered as desirable for the lighting of the cow house may be objected to here, and shutters may have to be provided. Feeders like their stock keeping in a subdued light, they rest better and fatten quicker. To this probably no exception can be taken, considering the brief life of the animal and the artificial existence led.

Regarding the facilities for distributing the food, the food storage and preparation departments must be conveniently placed, but food should not be stored under the same roof with the cattle.

The feeding and water troughs may be of galvanized iron, capable of being removed for washing, while the tying up method should be the short length of chain on the vertical rod fixed to the stall division, and attached at the other end by a strap around the animal's neck.

We have not touched on the question of ventilation, these buildings are not under the influence of any regulations, and practically no ventilation exists, excepting by such channels as may accidentally occur; but the principles previously laid down of inlets in the wall and outlets in the roof hold good.

When the roof is flat, through other places being overhead, ventilation can be carried on by opposite windows should they exist, or by outlets carried through the rooms above and opening on the roof, but this latter, as we have previously seen, is unsatisfactory.

*Cattle Boxes* may be arranged in a double row with a passage down the centre for the tram line, or they may form two or three sides of a square opening into a covered yard: the tramway in this case running between the wall and manger as in Fig. 138.

As a method of fattening there are many authorities who consider them superior to stalls, but it is to be feared that the prejudice in favour of boxes is largely based on the manure they are capable of furnishing, and not because they afford increased accommodation.

The ordinary fattening box is ten or twelve feet square, sometimes a little smaller, and not more than six feet high; between each box is a dwarf wall of brickwork two or three feet high, and the separation is completed by wooden rails, arranged horizontally, carried up to the roof.

The floor is dug out below the level of the outside ground and lined with concrete, so as to leave a depth of two or three feet below the ground level. This is done for the

collection of manure, as the fattening animal has to live on a manure heap until consigned to the butcher.

Day by day as the material accumulates a small quantity of fresh straw is added, which is generally cut in short lengths, and the whole is kneaded into a mass by the treading of the animal. This state of affairs goes on for months, the animal living on a semi-liquid manure heap, and the resulting material comes out in a ripe and highly desirable condition from an agricultural point of view.

We alluded to this filthy system when speaking of ventilation, and have frequently throughout these pages referred

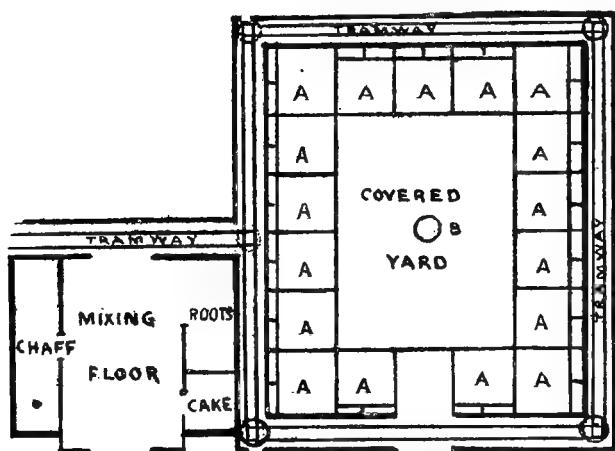

Fig. 138.—Portion of ground-plan of Covered Homestead. A A are the fattening boxes; B, water trough in covered yard.

to the importance of manure to the farmer in enabling him to spend more money on feeding, but we cannot give this method of saving manure and labour any countenance, and denounce it as insanitary and unhealthy.

The *Box and Yard* system of fattening is derived from the North of England, where it is known as the Hammel System, and has met with very general approval. A hammel is a box about 12 feet square, communicating with a yard of the same size (Fig. 139). In both the shed and yard, facilities for feeding and watering exist. The

manure in these places is not disturbed any more than in the box system, but the hammel is freely open to the outside air, and exhalations are considerably diluted.

It is said that cattle in hammels do much better than in boxes, and some advanced agriculturists\* have adopted the hammel system with certain modifications, and think highly of it. The hammel is practically the same system as that adopted for calves, which has been previously described; in both it is essential the floor should be made of concrete.

A very important point brought out in the communication just alluded to is the value of peat moss as litter; it is more absorbent than straw, and, as a manure, is ready for the land at any time. If this were generally adopted the box with the sunken floor might be dispensed with, and animals fattened without having to live for months on their own excreta.

*Open sheds with shelters* are freely used for the accommodation of fattening stock, especially in the earlier stages. They differ from hammels mainly by the fact that several animals are placed together, while in the hammel only one or two, or at the outside three, are placed within the same enclosure. These open sheds and yards are sometimes spoken of as *cattle courts*. They should be provided with sufficient manging and water supply; in all cases the animals stand on straw, which collects the fæces and urine, and in wet weather the courts are a squelching quagmire. Exposure to the weather, rain especially, greatly reduces the manurial value of the bedding, and has caused advanced agriculturists to devise something better; hence arose a controversy as to the

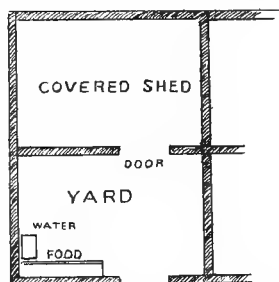

Fig. 139.—Box and yard used for fattening animals.

\* 'The Best Means of Increasing Home-Production of Beef': Mr. G. Murray, *Journal of the Royal Agricultural Society*, 3rd Series, vol. i., part ii., 1890.

relative value of open and covered yards, which has been decisively settled in favour of the latter.

*Open and Covered Yards.*—The size of these must depend upon the number of animals, but many think that small yards, say for ten head of cattle, are preferable to large ones. If open yards are used some shelter-shed for the cattle must be employed. These sheds should be provided with mangers or feeding troughs, while in the yard water for the animals must be available.

The covered yard is completely roofed over, by which means it is found the animals thrive on less food, and the valuable portions of the manure are not lost by rain, while there is also an economy in bedding, only about half the amount of straw being used.

The roof employed in these yards must be well ventilated, either of those in Figs. 84 and 85 may be used, in fact Fig. 85 is taken from an article on 'Covered Yards.'\* An open roof may be covered with slates or tiles, or the open roof-slating described on p. 278 may be employed; if economy is a very strong point a wooden roof of open boards, described on p. 279, may be used. Efficient ventilation is essential in covered yards, and each type of roof described meets this requirement.

*The Straw Yard*, as it is frequently termed (whether covered or uncovered), has another function to perform, a consideration of which we have reserved to the last; it is a sort of cesspit, into which all the liquid excreta from the byres and stables finds its way, to be absorbed by the bedding. Hence in a small farm it is centrally placed, and in a large one three or four exist, depending on circumstances.

Before the straw yard is formed the earth is excavated to a certain depth, and a situation is chosen into which and out of which there is drainage. The object of this is to ensure the reception of the full contents of the byres or boxes, while at the same time the liquid which filters

\* Mr. W. J. Moscrop, *Transactions of the Royal Agricultural Society of England*, 3rd Series, vol. i., 1890.

through should be capable of running off, so as to prevent the bedding getting too boggy. The liquid that runs off must on no account be lost as it is a powerful fertilizer, so the drainage from the straw yard is arranged to flow into a liquid manure tank.

No protest against this cesspool system is likely to be of the least use, we must therefore consider how the yard should be constituted to prevent the surrounding ground getting fouled.

The usual system is that the yard is dug out, with sides sloping towards the centre. It is lined with chalk if obtainable, or rammed brick, but never clay, which though impervious to moisture gets mixed up with the bedding. To secure a dry standing for the animals the bottom of the excavation is filled up with stubble, or better still, furze. From the lowest point of the excavation a drain pipe conveys the filtrate to the liquid manure tank, or direct to the manure heap.

Such is the established system recommended by agricultural authorities. It is one which the sanitarian cannot possibly countenance; the soil pollution in the neighbourhood of these yards must be excessive, especially bearing in mind they are only cleaned out every six months.

There can be no doubt from a hygienic point of view that straw yards should be concreted so as to prevent percolation, while the furze bottom should still be employed to allow the filtrate to escape, and so keep the bed of straw above fairly dry.

When the question of drainage is dealt with this matter will be touched on again, and we shall advise the straw yard not being used as a cesspool.

### *Piggeries.*

The piggery is the last building we have to consider for the accommodation of the animals of the farm, and the system of its arrangement depends upon whether a few or many pigs are kept.

A few can be disposed of in any conveniently situated building which affords protection from the weather, ventilation, a dry floor, and if possible a short run. It is usual to select a site for the piggery somewhere near the manure pit, the object being to conduct the excreta there, and to keep this class of animal as far as convenient from the others.

Whether a piggery is offensive or not depends upon the time devoted to its sanitation, which is often brief and at long intervals. There is no necessity for a piggery to be filthy, and in large well-ordered establishments devoted to the rearing of pigs this is far from being the case, in fact, would defeat the object of the breeder.

A pig requires a sty and a yard in front of it, in which is placed the feeding trough. The floor should be impervious, asphalt or blue Staffordshire brick, something which is not only sanitary but defies rooting up.

The trough is provided with a swing front, so that by pushing back the flap access to the trough is cut off, or by being pulled forward is rendered available to the animal (Fig. 141). Many breeders object to troughs in the sty, a question which will be again alluded to.

Part of the sty not unfrequently has a wooden bench where the animal can lie, but wooden floors such as have been recommended are decidedly objectionable from a sanitary standpoint.

Behind the sty runs a passage, and by means of this the sty can be cleaned out and fresh bedding put in.

A sow with young will require to have her sty with a rail all round, sufficiently high from the ground to allow the young pigs to run under, and so escape being laid on, for in this respect pigs are clumsy mothers.

Where the pig industry is predominant on a farm the arrangements are more elaborate. Fig. 140 shows the plan of a building devoted to pig breeding and rearing.

The accommodation for the animals includes sties not only for those fattening, but for boars, young pigs, sows in pig, and farrowing sties. The building is arranged on



three sides of a square open to the south, as pigs require both warmth and sunlight. The sties face a covered and open yard; they have a passage running behind for the purpose of cleaning them out, and here also the ventilation is regulated by sliding ventilators in the wall. The floor is blue brick, with sufficient slope to carry off the water. The form of feeding trough employed by the proprietor of this establishment, Mr. Tommas, is a circular one of iron, saucer shaped, about 2 feet in diameter which

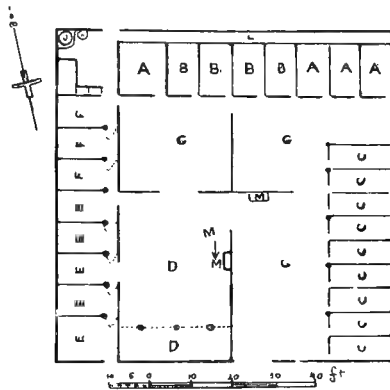

Fig. 140.—Mr. Tommas's piggery. A, farrowing sties; B, sties for young pigs; C, sties for boars; D, shed and yard for sows in pig; E, boxes for pigs; F, farrowing boxes; G, paved feeding and exercise yard; M, water troughs.

cannot be upset. The animals are not fed in the sties, but each pen is let out separately into the yard for feeding.

One half the sty is raised by a plank stage on which the animal rests. Mr. Tommas allows each pig about 27 square feet of space.

Mr. Howard\* lays great importance on a well-drained position for the piggery, with plenty of fresh air and light, and situated as distant as possible from the other animals of the farm. The buildings should be capable of being

\* 'Pigs and their Breeding and Management': Mr. J. Howard, M.P., *Journal of the Royal Agricultural Society*, 2nd series, vol. xviii., part i., 1881.

readily adapted to the requirements of winter ; they should be easy of access for removal of manure, while the flooring of hard bricks laid in cement is preferred by him to asphalt, which is slippery, though he recognises its cleanliness and healthiness. Wooden floors he condemns on sanitary grounds.

Howard lays great stress on the absence of feeding troughs to the pens. Each pen of pigs is brought out into the yards D G for feeding purposes ; in this way regular feeding is ensured, and the animals thrive better.

Iron fittings for piggeries may be seen in Fig. 141.

### *Sheep Shelters.*

It will be convenient here to consider the form of shelter adopted for sheep during inclement weather. Under ordinary circumstances no regular shelter is provided in farms for sheep, they are left on the land, it being considered that their natural fleece is sufficient protection.

To an extent this may be right, rain cannot penetrate the wool owing to its greasy nature, and cold certainly cannot seriously affect unshorn sheep, but it is a question which has often been under consideration whether sheep would not be better for some permanent shelter, not only for the comfort of the animal, but to prevent injury done to the fleece by exposure, and disease of the feet due to wet weather.

Scott\* describes buildings for fattening sheep, consisting of a sheep floor on either side of a centre feeding passage. The sheep floor is laid with concrete, but dug out from half to one foot below the ordinary ground level, the bedding employed being straw, sawdust, or dry earth.

This floor, it will be observed, is on the same principle as the floor of the fattening boxes for cattle, viz., living on their own excreta. In this light it cannot be countenanced,

\* 'Farm Buildings': Professor J. Scott.

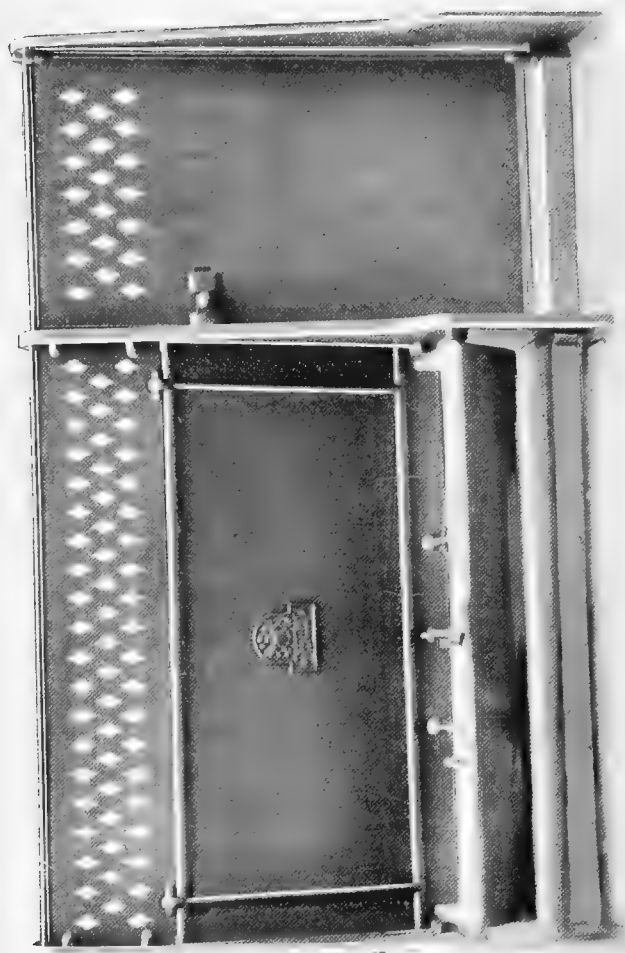

Fig. 141.—Iron Fittings for *Pigeon-hole* (Mansgrave). In the figure the swing flap over the trough is pushed back, thus cutting it off from the sty.

*Table 141.*



and we advise an impervious asphalt floor with moss litter as bedding, which should be sufficient to absorb all the liquid excreta.

Scott places the building at 50 feet by 18 feet, with a feeding passage of 4 feet down the centre (Fig. 142), and this he considers as ample accommodation for one hundred sheep; the superficial area allowed being 7 square feet per head.

At the end of the building are the food stores and mixing floor, while on either side of the passage the feeding troughs are arranged. As the sheep shed is only 50 feet long, and there are 50 sheep in each, it is quite certain the whole of these cannot feed at one time. Scott tells us that in these sheep sheds the animals fatten more rapidly and economically than out of doors.

The same authority figures the ground-plan of an

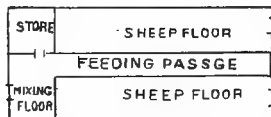

Fig. 142.—Buildings for Sheep.

American sheep barn, which consists of covered sheds for sheep around three sides of a barn, the fattening shed, ewe shed, and ram shed being distinct, with a yard to each. In addition there are lambing pens and stores for food and wool.

Sheep can be sheltered in the open by very inexpensive methods, the most common is the stuffed hurdle, viz., two hurdles face to face with a good layer of straw between them. These may be used either placed vertically in the ground, the sheep seeking the lee side, or they may be inclined towards each other  $\Lambda$  fashion, or as a lean-to against a fence or wall: even a house may be built of hurdles by driving in sufficient to form three walls and using others as a roof.

Galvanized iron in sheets may also be employed as a lean-to, but these must be secured in some way, as loose sheets are dangerous in a high wind.



Fig. 143.

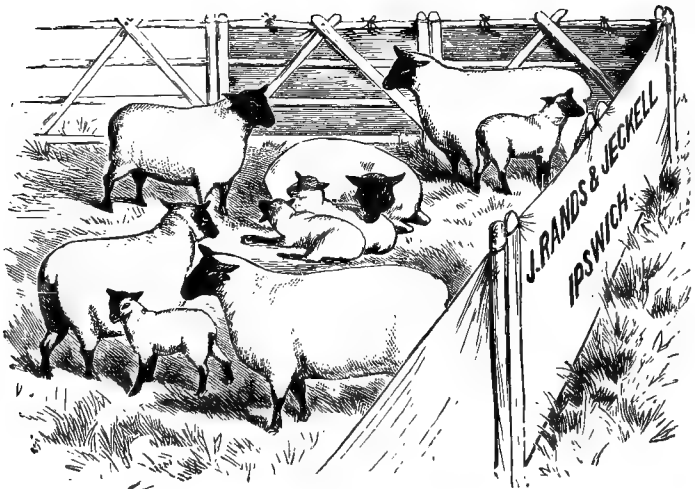

Fig. 144.

Shelter cloths placed on hurdles are now used as a protection for sheep; they are arranged either as in Fig. 143 or Fig. 144.

The ordinary lambing fold is made of hurdles stuffed or

unstuffed; two or more folds may be required, into one are placed the ewes awaiting lambing, while in the other are the ewes and lambs.

The first fold should contain shelter sheds all round, while in the fold for lambing ewes there should be covered pens, about one hurdle square, into which the ewes are placed as they lamb (Fig. 145).

Some care should be taken in the selection of a site for a lambing fold, the soil must be dry, the situation protected, and as close as convenient to the homestead. A portable shepherd's hut is a great convenience, and may be placed in the centre of the fold.

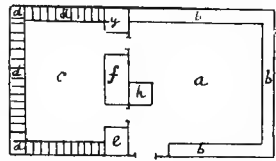

Fig. 145.—Plan of sheep fold for lambing (Scott). *a*, Yard for unlambing ewes; *b b b*, hurdle sheds; *c*, yard for lambing ewes; *d d d*, covered pens; *e*, straw; *f*, roots; *g*, hay; *h*, shepherd's hut.

#### HOSPITALS.

Though these have been reserved for separate consideration, there is very little in them to differ from the most approved type of industrial stable previously described. But it is necessary to emphasise the absolute importance of ample superficial and cubic space, this must be greater than the amount allowed in health, especially the superficial area. An interval of 5 feet 6 inches in a stable with swing bails is sufficient for horses of medium size in a state of health, but not for those suffering from disease.

It may be claimed that most sick horses are treated in boxes, and this no doubt is true for very serious cases, but box accommodation is expensive, and in large hospitals the majority of surgical cases have to be treated in stalls.

Surgical cases, especially wounds, cannot have the stables too freely ventilated; hospitals, unlike ordinary stables, are always occupied. It is true both boxes and stalls are given every chance of a rest, but in a large hospital this is not always possible, and large suppurating wounds or foot cases, are both important sources of air poisoning.

Long continued air poisoning means that all surrounding objects become infected, wood-work, walls, fittings, mangers, etc. In the construction of hospital stables everything possible should be made of iron, no wooden posts, bails, or mangers should be allowed.

The walls should be plastered the whole way up, and coated with a smooth faced cement readily cleaned either by brush or hose.

The manger pan in every case should be capable of removal, so that it may be thoroughly cleaned and disinfected. There should be no corners in any of the iron or other work for the lodgment of dirt. The building must be well lighted up, for both light and fresh air are destructive to micro-organisms.

Water should be freely laid on in every stable for the thorough cleansing of the floor and fittings, though in wet and cold weather this must be employed with discrimination. The flooring must be impervious and the drainage surface.

The boxes should be from 1,500 to 2,000 cubic feet capacity, and in other respects should conform to the sanitary requirements laid down for stables. Boxes with walls of deep neutral tint may be needed for eye cases, and means at hand for excluding the light; but all others should have daylight and fresh air in abundance.

A circular padded box for colic cases would prove a useful addition.

A separate place should be erected for the washing and dressing of wounds; both these operations are better performed outside the hospital stables. A good water supply, an impervious floor, and good drainage are requisites; there should also be convenience for destroying the old dressings by fire.

A specially prepared surface for trotting lame horses is most desirable.

A boiler is a necessary adjunct in the preparation of the food for the sick and for other purposes.

An impervious surface is necessary for post-mortem examinations. A covered place well lighted from above,



with a prepared floor, is essential for operations; this building should be provided with water and the needful convenience for instruments.

A suitable exercising ground for convalescents should be available, while paddocks if obtainable would prove invaluable.

A vapour bath is a most useful accessory in a hospital, but should an outside source of steam not be available for connection with it, these baths prove troublesome unless in regular use.

In addition to the ordinary hospital buildings, other stables both boxes and stalls are required for such cases as need isolation. These isolation buildings do not differ in construction from those previously described, but it is most important they should form a block, not only apart from the other places, but completely self-contained, viz., their own forage store, place for dressing wounds, exercising ground, etc. It should also be provided with a separate entrance, everything in fact done to render it completely isolated.

Facilities should also exist for the disinfection of the clothing worn by the horses and men in attendance, and the latter should be provided with means for washing and disinfecting themselves when necessary.

The above remarks necessarily refer to specially established hospitals; but even with large private stables facilities should exist for the treatment of the sick, and special boxes for this purpose, isolated from the other part of the building, are now sometimes erected. They are most desirable, for the sick cannot with safety or satisfaction be treated in the ordinary stable.

Even the homestead should not be without facilities for this purpose, and especially is this the case in a dairy farm, where, depending on its size, one or more boxes should exist for calving purposes. On no account should cows be permitted to calve in the ordinary byre, or abortion amongst the others may occur.

PREVENTION OF THE KEEPING OF ANIMALS ON ANY PREMISES  
SO AS TO BE INJURIOUS TO HEALTH.

By Section 44 of the Public Health Act, 1875, it is provided that an Urban Authority may, among other things, make bye-laws 'for the prevention of the keeping of animals on any premises so as to be injurious to health.' The health referred to is not that of the animals concerned, but of man.

The Local Government Board have issued a series of proposed bye-laws on the subject, which are here reproduced:—

13.\* The occupier of any premises shall not keep any swine† or deposit any swine's dung within the distance of 100 feet from any dwelling-house.

13a. The occupier of any premises shall not keep any swine within the distance of 100 feet from any dwelling-house, unless the sty or place in which such swine are kept be maintained in a cleanly and wholesome condition.

14. The occupier of any premises shall not keep any cattle or swine or deposit the dung of any cattle or swine in such a situation or in such a manner as to pollute any water supplied for use, or used, or likely to be used, by man for drinking or domestic purposes or for manufacturing drinks for the use of man, or any water used or likely to be used in any dairy.

15. Every occupier of a building or premises wherein or whereon any horse or other beast of draught or burden or any cattle or swine may be kept shall provide, in connection with such building or premises, a suitable receptacle for dung, manure, soil, filth, or other offensive or noxious matter which may, from time to time, be produced in the keeping of any such animal in such building or upon such premises. He shall cause such receptacle to be constructed so that the bottom or floor thereof shall not in any case be lower than the surface of the ground adjoining such receptacle. He shall also cause such receptacle to be constructed in such a manner and of such materials and to be maintained at all times in such a condition as to prevent any escape

---

\* The Board suggest that in the case of a rural district the following clause (13a) should be substituted for this clause.

† The Public Health (London) Act, 1891, prohibits pigs being kept in the Metropolis within 40 yards of a street. A petty sessional Court may also prohibit the keeping of any animal in any specified place shown to be unfit for the purpose.

of the contents thereof, or any soakage therefrom, into the ground or into the wall of any building. He shall cause such receptacle to be furnished with a suitable cover, and, when not required to be open, to be kept properly covered.

He shall likewise provide in connection with such building or premises a sufficient drain constructed in such a manner and of such materials and maintained at all times in such a condition as effectually to convey all urine or liquid filth or refuse therefrom into a sewer, cess-pool, or other proper receptacle.

He shall, once at least in every week, remove or cause to be removed from the receptacle provided in accordance with the requirements of this bye-law all dung, manure, soil, filth, or other offensive or noxious matter produced in or upon such building or premises and deposited in such receptacle.

## CHAPTER VI

### DISPOSAL OF EXCRETA

THIS question presents a wider aspect to the human than to the veterinary hygienist. The former has to deal with (1) the actual excreta of the population; (2) the waste waters from houses containing urine, soap, dirt, grease, and organic matters from cooking operations; (3) domestic refuse consisting of ashes, cinders, waste food, etc.; (4) street refuses; (5) the solid and liquid refuse from manufactories, stables, cowsheds, and slaughter-houses.

The method adopted in many cities for the removal of excreta is what is known as the water-carriage system; everything mentioned above excepting ashes, cinders, waste food, and street sweepings, pass into the general drainage system being carried forward by water. The other method is the conservancy system, in which the faecal excreta of the population is dealt with separately, while everything else, with the previously-mentioned exceptions, passes into the drains.

It is very evident from this that drains and sewers are the monopoly of the medical officer, and that in towns and cities excreta from animals pass into them as a matter of general convenience. We have a joint interest with the medical officer in the matter of sewers working well, but their inefficiency or inadequacy is dealt with by him.

The drainage arrangements of a stable are matters of great simplicity compared to the complex methods which have at times to be adopted in houses for closets, baths, kitchens, etc., so that the aspect of the question from a veterinary point of view is by no means a difficult one.

On the other hand, where no general drainage system

exists, and the excreta of a farm has to be dealt with, the veterinary hygienist may play a more active part, for the drainage of the homestead becomes one of the greatest moment. We have previously learned the supreme importance to the farmer of saving all liquid and solid manure, it is everything to him and represents so much floating capital. In endeavouring to carry this out we must avoid sacrificing health to prejudice, though no effort should be neglected to provide for the liquid and solid manure being saved as far as possible.

The influence of good drainage on the general health of the community is undoubtedly very great, and the ill effects of bad or defective drainage are equally well marked; but among animals there are certainly no diseases specially attributable to defective drainage, though it contributes with other insanitary conditions to a general lowering of the state of health, and hence of body resistance.

In dealing with the question of stable drainage it will be found intimately mixed up with that of flooring. This was referred to before in dealing with stable pavement. It is also necessary to remember, and the point was noted previously, that the question of ventilation is associated with the removal of excreta, owing to the fact that animals have to live, eat, and sleep on the ground, often in the very place where they defæcate and urinate.

The removal of solid excreta by hand, such as occurs in stables and cowsheds, is a great help to the drainage system, as the bulk of the material which then finds its way into the drain is the urine. From a manurial point of view urine is bulk for bulk infinitely more valuable than the solid excreta, but it is very often lost through ignorance.

*The daily amount of excreta* evacuated by animals must necessarily vary with the nature and amount of the diet. The mean of several experiments made by different observers is here given:—

The daily average mixed excreta of the horse is	47·8	lbs.
"    "    "    "    "    "    "    "    "    "    "    "	cow is	82·0 "
"    "    "    "    "    "    "    "    "    "    "    "	sheep is	3·8 "
"    "    "    "    "    "    "    "    "    "    "    "	pig is	10·7 "

In the mixed excreta of all animals but the pig, the fæces are in larger amounts than urine; in the pig, as in man, there is more urine than fæces, though this again depends upon the nature of the diet. In making this comparison it is to be understood the excreta is weighed in its natural state and not dried.

Only a small proportion of the solid excreta finds its way down drains; on the other hand, the bulk of the fluid material escapes by this channel. The daily amount of urine may, on an average, be taken at:—

14 lbs.	per diem	for horses
26	„	„ cattle
10	„	„ pigs
1	„	„ sheep

These amounts are liable to great variation, depending on diet, season, etc., so that the above can only be regarded as mean quantities obtained by different observers.

Dyer\* states that a fair average annual production of manure per ton of live weight is 25 tons of a mixture of excreta and litter combined, and this after remaining in a manure pit for an average duration of time weighs 19 tons.

The urine of the herbivora readily undergoes chemical change, the urea breaking up into ammonium carbonate, which gives a distinctive odour to badly-ventilated and ill-drained stables.†

The fæces of the herbivora present great differences in their physical condition due to the amount of water they contain; in the horse they are moulded into balls and comparatively firm; in the ox they are pultaceous; in the sheep firm and dry; in the pig human like and offensive.

\* Dr. B. Dyer, 'Conservation of Farm Yard Manure,' *Journal Royal Agricultural Society*, vol. iv., part iv.

† During the Napoleonic wars the supply of nitre for gunpowder was cut off by the British fleet, but the old stables of Paris afforded an unfailling source. The mortar was found to consist of nitrate of lime, which was formed by the nitrifying organisms from the ammonia of the stable air. The nitrate of lime formed an abundant crystalline crop, from which nitre was readily obtained.—Dr. Aitken, *Transactions of the Highland and Agricultural Society*, 5th Series, vol. xi.

Every effort is made on the farm to conserve both the liquid and solid excrement of cattle, but excepting the fæces there is no attempt to collect that from the horse, probably for the reason that as this animal spends only half its life in the stable, it would be scarcely worth the trouble. The subject is mentioned here not in the interest of the farmer, but in that of the sanitarian, who must remember that though something under 50 lbs. of excreta are produced by a horse in a day, only a portion of this is deposited in the stable. The remainder goes to swell the refuse of our streets, and helps contaminate the air of cities with particles of dried horse fæces.

Drainage may be surface or subsoil, or a mixture of the two—*e.g.*, within the building the drains may be purely surface, while outside they may empty their contents into the ordinary underground system.

*Surface Drainage.*—The advantage of surface drainage from a sanitary point of view is considerable; there is nothing covered up, the whole can be inspected from end to end, there are no pent-up gases, and there is free dilution with air of the contents of the drain. There is no reason why on farms, which always have to inaugurate a system of their own, surface drains should not be more generally used; they need not offend the eye, and provided storm drainage and soil is kept out of them, so as not to unduly fill or dilute the contents of the liquid manure-tank into which they subsequently empty, there can be no possible exception taken.

It is seldom perhaps that surface drainage on an extensive scale will be permitted, though it has economy, cleanliness, and freedom from obstruction to recommend it; further there is nothing to get out of order, no returned gases to deal with, no pipes to become obstructed, but it offends the eye; we prefer as a rule to carry excreta out of sight, and by so doing introduce a system which is frequently defective and always risky.

Within buildings like stables and cow-sheds there can be no serious objection to surface drainage, and here it should

be the rule. In the highest class of stable it is not permitted on the score of appearance, with the result that traps and subsoil drainage have to be introduced. Where no such prejudice exists the rule is to convey nothing underground which can be carried on the surface.

Surface drains are made of various materials, in stables the most common and durable being some form of vitrified brick; in cow-houses a cemented gutter running behind the animals serves to take both the solid and liquid excreta.

In the case of stables the open channel runs at the rear of the stalls, and receives at right angles to it the drainage from each stall or box. The material from the stall or box finds its way into the surface channel by the inclination given to the floor at the time it is paved.

We have touched on this question under stable construction, and insisted that no greater inclination should be given to the floor than is absolutely necessary; the short length of a stall does not necessitate a steep gradient; provided the stall is lower behind than it is in front, the direction of the flow of urine is assured, and more than this is not required. Sometimes the stall slopes not only from front to rear, but from side to side towards the centre; there is no objection to this provided the slope is not excessive, but as a rule it is too great. If the centre of the stall is half an inch lower than the sides, the direction taken by the fluid must be towards the centre.

There is no other object in sloping the sides of the stall towards the centre than that of directing the urine away from the woodwork of the stall, though this can now be guarded against by using stall fittings which do not quite touch the ground.

The surface drainage of boxes is generally an incline from three or four sides towards the centre, but the slope required is very slight.

In all the cases considered it has been assumed that the ordinary vitrified brick has been used either plain or grooved. With the latter there should be no difficulty in manufacturing bricks with a graduated depth of groove,



and in this way the floor of stalls and boxes could be laid perfectly level, the increasing depth of groove from side to centre and front to rear being depended upon to carry off the fluid.

The open channel running behind the horses which receives the drainage from stalls and boxes is made shallow and moderately wide; a foot in width in a small stable is amply sufficient, and a depth of  $1\frac{1}{2}$  inches in the centre should be enough to keep the contents together.

The surface drain is led outside the stable, and it must therefore have a fall. In a long stable the fall should be from the centre to both ends, in a short stable it need only be in one direction. The surface drain having passed out-

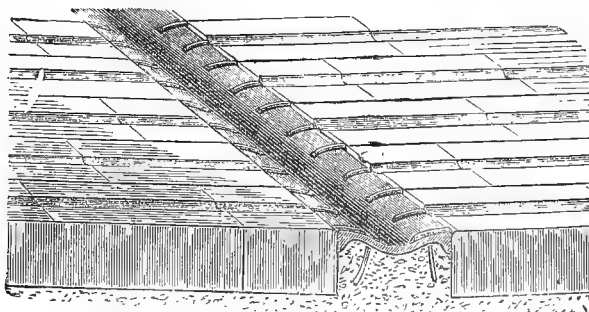

Fig. 146.—Floor laid with the Paving Brick shown in Fig. 88, and Iron Surface-drain.

side the stable, is carried twelve feet clear of it, and discharges into a trapped gully, which empties its contents into the sewer pipe.

It will be observed that by this system of surface drainage the interior of the stable or cow-shed is not in communication with the drains; it is an ideal sanitary system for all stables, especially those where a large number of animals are brought under one roof. A plan of the system for a large stable may be seen in Fig. 117, while Fig. 130 shows a similar arrangement for a cow-house.

Sometimes surface drains are made to discharge their contents into traps situated within the stable, but this helps to destroy the value of the system.

There is a surface-drain made of iron and roughened to give a foothold (Fig. 146), but it is not clear what advantages it possesses over one of brickwork. There is also a modified form of surface drainage such as is seen at

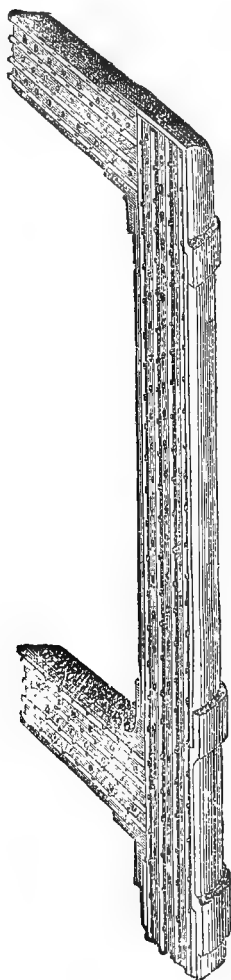
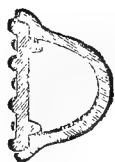

Fig. 147.—Covered Surface-drain with Movable Cover



Section of Fig. 147.

Fig. 147, where the drains are iron throughout and possess perforated iron movable covers which hide their contents, but do not hinder the entry of urine. The movable cover admits of ready access for the purpose of cleaning out.

This type of drain is very often spoiled by the introduction of traps in the stable, into which the contents are emptied, and thus the system is vitiated. The iron-covered surface drain is only suited to small stables, and if traps are introduced the expense might as well be avoided.

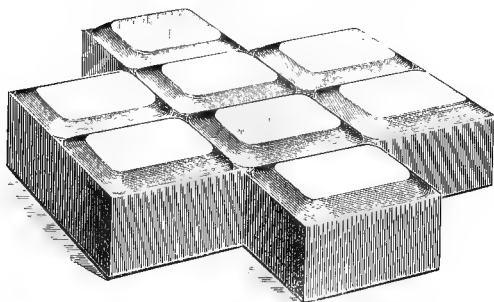

Fig. 148.—Vitrified Blue Paving Brick.  
9 inches  $\times$   $4\frac{1}{2}$  inches  $\times$  3 inches deep (2 panels).

*Paving.*—It is here convenient to consider the question of paving, which is so intimately associated with the surface drainage of stables. Its general principles have already been considered (p. 282), but there are constructive details which must now occupy our attention.

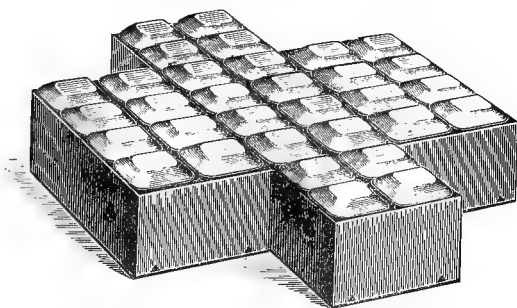

Fig. 149.—Vitrified Blue Paving Brick.  
9 inches  $\times$   $4\frac{1}{2}$  inches  $\times$  3 inches deep (8 panels).

Figs. 148-151 show different forms of grooved bricks used in stables; it is far from clear what advantage one has over the other, though the general conception of the part these grooves play is that they prevent slipping. This is certainly not the case. There is no brick which can

prevent slipping unless the horse can get the toe of his foot right into it; perhaps the one with a single groove (Fig. 88), if placed transversely in the stall, would be the nearest approach to what is required.

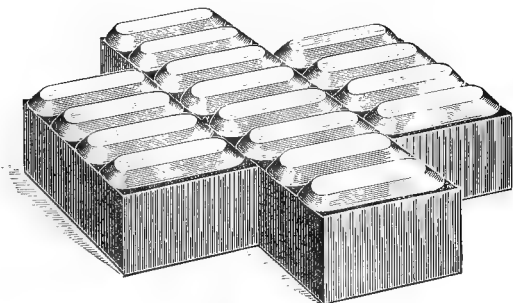

Fig. 150.—Vitrified Blue Paving Brick.  
9 inches  $\times$   $4\frac{1}{2}$  inches  $\times$  3 inches deep (4 panels).

Considerable ingenuity has been devoted to the question of arranging the bricks in the stalls and passages in order to prevent slipping. Fig. 152 shows some of the patterns employed. There are arguments in favour of each, but perhaps that at *b* and *d* (Fig. 152) are most suitable. These

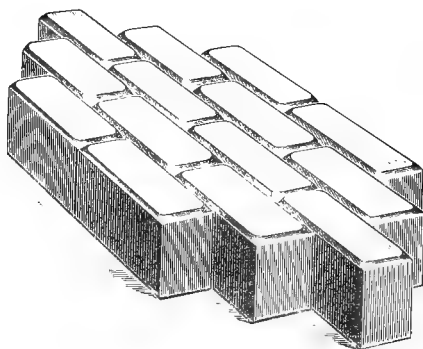

Fig. 151.—Vitrified Blue Paving Brick.  
8 inches  $\times$   $2\frac{3}{4}$  inches, with single groove.

remarks on Fig. 152 apply only to the arrangement of the paving bricks; the trap seen in the middle of the figure is not approved.

The paving of a loose box affords still further scope for

geometrical devices as at Fig. 153. The patterns are unobjectionable, but unnecessary. In this figure the trap in the box is a blot on the arrangement.

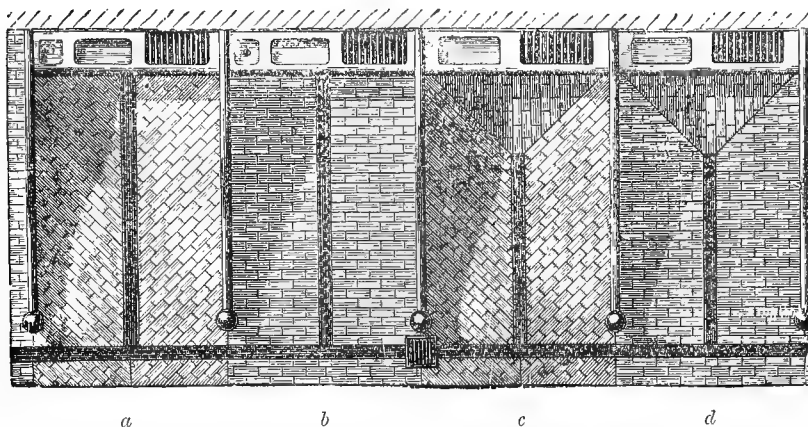

Fig. 152.—Methods of laying Paving Bricks in Stalls ; *b* and *d* are good arrangements.

Whatever pattern of brick or other material used for paving, it must rest on a solid concrete foundation.

The passage of a stable is not infrequently paved herring-bone pattern ; it is effective in appearance, but possesses no hygienic advantage. For industrial stables the most

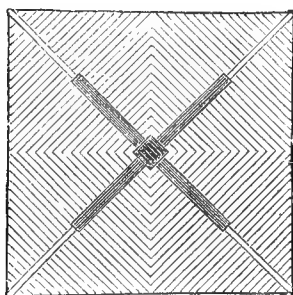

Fig. 153.—Loose Box Paving.

useful paving both for the passages and stalls is the ordinary square granite block set in cement. It is durable, but like all other paving is slippery.

*Surface-drainage of cow-sheds* should be insisted upon under the powers given to Local Authorities by the Dairies, Cow-sheds, and Milk-shops Order. Not only must the drainage be surface, but no traps of any kind are allowed in the building. It is to be regretted that all Local Authorities do not avail themselves of the powers they possess under this Order, but they are frequently interested parties, either as landlords or tenants, and naturally do not encourage the expense.

The surface drain of a cow-shed is frequently a gutter 18 inches wide running immediately behind the animals, and of a depth of 6 inches (see Fig. 132). It is made of this shape to ensure the collection of all liquid, and as much solid material as possible. Fig. 131 shows the most approved system, the drain being wider and shallower than that just mentioned. Whatever plan is adopted the channel is cemented from end to end, and passes out of the cow-house, at 12 feet from which it may empty either into a trapped drain or into a cemented receptacle (Fig. 130, *t*), from which the contents are removed by a liquid manure cart and taken to the general tank.

The system adopted outside the building must depend upon the type of drainage in existence, and the matter will be referred to again in describing the subsoil drainage of farms.

*Underground or subsoil drains* for use in a stable are to be condemned, but as people insist on having them it is desirable to consider how they can be best employed without creating a nuisance. Before this subject can be dealt with, it is necessary to discuss the appliances used in subsoil drainage, viz., pipes and their accessories.

*Pipes and Drains.*—Pipes are made of stoneware, and are salt- or glass-glazed to render them impervious. They are circular in section, and vary in diameter from 2 to 36 inches; while in length they are about 2 feet. Each pipe has one end provided with a collar or socket, into which is adjusted the spigot end of the preceding pipe; it is a rule that the collar end of a pipe points towards the head of the drain, and not towards the outlet.

The joint between the pipes must be made water-tight by the use of neat Portland cement ; but none of this must find its way into the interior, or a projecting rim will be formed which will produce an obstruction.

Pipes near the surface, as in a stable, are liable to be displaced, and must be laid on brickwork or concrete. The same method must be adopted where the drains pass through recently made ground, or ground likely to be affected by settlement which would lead to fracture of the pipe. Where the ground is solid and good, the drain pipes outside a building may rest on it with a slight excavation for the collar, or better still laid on a brick supporting each pipe in front of the collar.

Drains should run as nearly straight as possible, every angle or elbow forms a possible source of obstruction, and reduces the rate of flow of the contents. Where a branch drain joins a main drain care should be taken that the pipe enters by a V-shaped junction (Fig. 155), so as to ensure its contents being delivered in the line of flow of the main current. A right-angled junction would only lead to obstruction.

Where, as in farms or large blocks of stabling, several drains may have to be coupled together, a man-hole or inspection chamber should be established, so that in the event of stoppage the parts are readily got at. A man-hole inspection chamber should also exist wherever the drain has to undergo a change of direction, this ensures that the pipes shall run in a straight line between each man-hole.

Where the drains pass through the man-hole, only half pipes are used, so that the contents may be seen and ready access afforded.

Sometimes half pipes with a cover (Fig. 154) are employed at intervals so as to afford access in case of a block. These are useful on a long length of drain.

For small stables a pipe of 4 inches in diameter is quite large enough, for a larger stable a 6-inch pipe ; it is seldom anything bigger than this is required. It is a great

error to put down a larger pipe than necessary, as the solid contents get left behind; within reason the smaller the pipe the better the flushing.

The gradient given to a drain is a very important matter, if too steep the water runs off and leaves the solids behind, if too shallow the drain is insufficiently emptied.

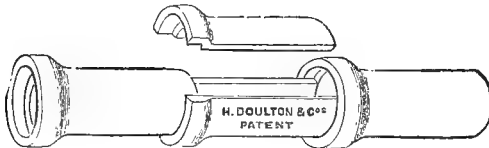

Fig. 154.—Access Pipe.

The gradient depends upon the diameter of the pipes, the smaller the pipe the steeper the gradient; what the sanitary engineer aims at is a continuous flow throughout the entire system of between 3 and 4 feet per second. In the case of a 4-inch pipe this is secured by a gradient of 1 in 40, of a 6-inch pipe by one of 1 in 60, of a 9-inch pipe by one of 1 in 90.

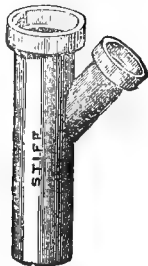

Fig. 155.—Single Junction, with Diminishing Pipe.

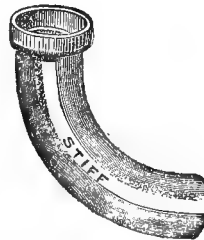

Fig. 156.—A Bend

A pipe must always open into one larger than itself, a diminishing pipe being employed on the larger drain to enable the junction to be effected (Fig. 155).

Junctions are very important points to inspect, the joints are frequently defective, or from want of a diminishing pipe are made to offend against one of the cardinal rules of drainage.



Bends (Fig. 156) also require looking to; instead of being made with curved pipes they are not uncommonly made with straight pipes fitted into each other so as to give the needful curvature, and leaking at every joint.

For the purpose of description all pipes within a building are known as *stable pipes*, those outside it which conduct the material from the building to the sewer are known as *sewer pipes*, while the main drain, which in cities is placed in the middle of the street and receives the contents of all the buildings, is known as the *sewer*.

*Sewers* are the channels into which the combined drainage system empties, and these unite and reunite until one or more channels of considerable size are formed towards the outlet. When sewers were first established they were built of brick which was pervious, and it was found that they conveyed away not only the material poured into them, but also water from the soil, which passed in through the imperfect joints. The general effect of this sewer system was to lower the height of the ground water in cities, and raise the general health of the inhabitants. In this respect they did immense good, but it was found that not only did water pass in through the brickwork, but drainage frequently passed out, so that soil pollution became common, and poisoning of the ground air and well water occurred.

Sewers are now rendered impervious by the use of glazed fire bricks with Portland cement for the joints; in section they are egg-shaped, the narrowed end being below, this is found to be the form which gives rise to the least friction with the contents.

Inspection chambers are arranged wherever a change of direction occurs, and at other intervals for the purpose of cleaning. These manholes are also used for the purpose of ventilation, the ventilation of sewers being an important point to attend to in sanitary legislation.

The outlet of a sewer is generally a river; in days gone by the crude material was poured direct into it, and extreme pollution occurred. Now the sewage has to be

treated and purified before it is allowed to enter, but there are still places where the difficulties of treatment are so great that the old system of pollution exists.

*Disposal of Sewage.*—One of the greatest problems in sanitary science is the disposal of sewage; from a veterinary standpoint the question is only of general interest, as the matter lies in other hands. As the case stands at present the sewage must either be purified and then allowed to pass into rivers, or utilized on the land.

The latter sounds a simple and feasible system, but in practice it is found that the manurial value of sewage, owing to its enormous dilution, is very small; sewage farms are generally receptacles for large volumes of very impure water, which by passing through the earth undergoes a rough process of filtration, the effluent passing into the nearest stream.

The value of a sewage farm unless under the most careful management, is from an agricultural point of view very disappointing. It generally grows a rank rye grass which obtains a local sale, and so helps to cover the cost; but the soil unless under careful management soon gets 'sewage sick.'

Attempts have been made to purify sewage by precipitation with various chemical re-agents, by electrolytic decomposition, and in other ways, but this still leaves the deposit or sludge to be dealt with. This latter is frequently dried, pressed into cakes, got rid of for such manurial value as it possesses, which is very small, or burnt in a cinerator. The sludge is always the difficulty in precipitation processes.

Another method of disposing of sewage is the biological, viz., by means of micro-organisms. There are several processes in use, but the general principle involved is the collection of the sewage in tanks, where it is first exposed to the action of its own organisms, which in the absence of oxygen render the organic matter soluble with the production of ammonia and carbonic acid. After this it is attacked in a second tank by another set of

organisms which in the presence of oxygen nitrify the ammonia, converting it into nitrous and nitric acids. The effluent is then passed on to the land and got rid of by filtration. This process has the great advantage of leaving little or no sludge to be dealt with. A fuller account of the above process of nitrification will be given under 'Soils.'

*Ventilation of Drains.*—In speaking of the disadvantages of subsoil drainage in stables, we referred to the fact that it leads to the air of the building being placed in connection with the sewer, and that the result of this might possibly become serious. The object of ventilating drains is to prevent this occurring, and to cut off the interior of a building from the interior of the sewer, by means of an opening outside the building which communicates freely with the outside air. Under these circumstances any reflux of sewer gas would escape outside and not inside the building.

There are other means of preventing sewer gas finding its way into buildings, viz., by means of traps, but traps can only be considered as auxiliaries to a good drainage system, and without ventilation they cannot be relied on. The chief means of preventing the sewer-gas pollution of buildings is by disconnecting the drains by ventilation.

The disconnection takes place outside the building where the stable drain joins the sewer drain, and is accomplished by the introduction of a disconnection syphon such as may be seen in Fig. 158. The principle on which this works is that under ordinary circumstances the water seal in the syphon is sufficient to keep back the sewer air, but in the event of it not doing so, the sewer gas escapes through the fresh air inlet G.

By means of this inlet the air in the stable drain up to the stable trap is quite unpolluted, so that should this trap fail to act no fear of sewer gas need be apprehended.

It is usual in large buildings, where several drains join before passing to the sewer, to have a disconnecting man-hole based on much the same principle.

*Traps.*—A trap is placed wherever the air of a building

communicates with the interior of a drain. It is a contrivance which holds water, and so arranged that the water acts as a seal between the building and the drain; of itself it is insufficient protection against sewer air, hence the reason for disconnection just discussed, but as a valuable accessory it is indispensable.

Traps without ventilation cannot be depended upon, for the reason that the pressure of gas in the sewer pipe may be sufficient to force the seal. Or the water in the trap may absorb the sewer gas at one side and give it off at the other. Further, evaporation may cause the water to fall below the tongue of the trap, and thus open the passage for sewer air.

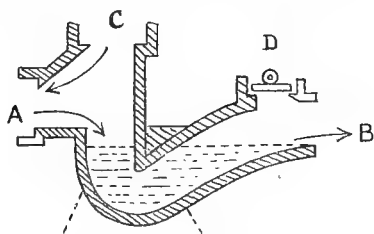

Fig. 157.—Buchan's Disconnecting Syphon. The sewage enters at A and escapes into the sewer pipe at B. D is an access opening in case of an obstruction. C communicates with the outside air, and ensures the air in the stable pipe being pure.

Traps are of various kinds and their construction depends upon where they are to be placed. Fig. 157 is a syphon trap; the arrows show the inlet and outlet, between which is interposed a volume of water which should stand not less than  $\frac{3}{4}$  inch above the highest level of the water in the bend. The interior of a syphon must be smooth, the descent should be sharp, the ascent more gradual, so as to offer no impediment to the flow; the flat bottom ensures it being laid level, for on no account must the outlet be higher than the inlet. In Fig. 157, two openings besides inlet and outlet are seen. This is a disconnecting syphon; the opening near the entry is carried up to the level of the ground and is covered by a grating (Fig. 158); it is an air inlet, and if necessary a foul gas outlet. The opening near the outlet is

closed with a properly prepared cap, Fig. 157, D, and is only used for examining the drain in case of an obstruction.

Other forms of syphons are seen at Figs. 159-161. In the use of syphons it is a rule that when two succeed each other in the same drain, an air opening must exist between them, as otherwise the action of the second syphon is to suck the water out of the first.

A *Dip Trap* was frequently used in old drainage systems. It consisted of a brick chamber containing water, the inlet and outlet being above the water-line; dividing the two and

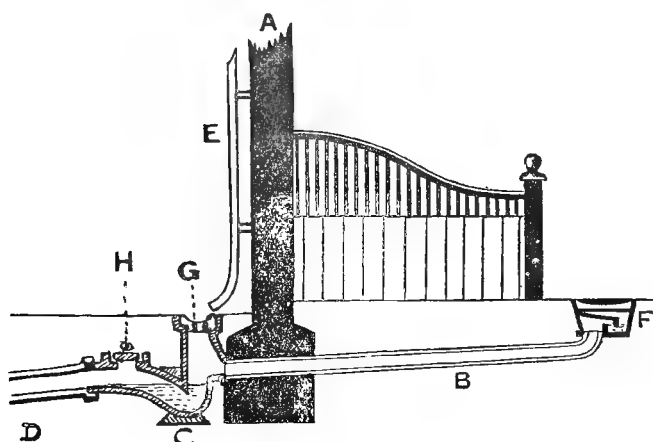

Fig. 158.—Ventilation of stable drains. F, stable trap; B, stable pipe; C, disconnecting syphon; D, sewer pipe; E, water pipe from roof opening over G, grating covering fresh air inlet; H, access opening.

dipping down into the water was a tongue of stone. It was a bad form of trap and little better than a cesspool; further, it was liable to choke and could not be easily cleaned out.

The *D Trap* is a metal box like an inverted U, with an inlet which runs under the water contained in the chamber, and an outlet above. It is probably the worst form of trap ever devised; it is neither self cleansing, nor can it be got at for cleaning purposes—two cardinal points in the matter of traps.

The *Bell Trap* (Fig. 162) commonly used in stables is nearly as bad, it is difficult to clean, is readily untrapped

by the removal of the bell, and deserves the name applied to it of 'the domestic air poisoner.' No trap can be effective the trapping system of which is under control.

Traps used in the interior of stables require special con-

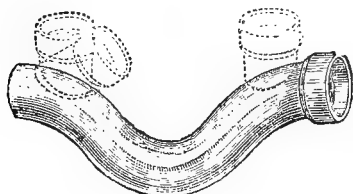

Fig. 159.—Ventilating Syphon.



Fig. 160.—Access Syphon.

struction to prevent bedding finding its way into and blocking the drain; to prevent this a perforated tray is frequently introduced as in Figs. 162 and 163. Besides bedding,



Fig. 161.—A Simple Syphon.

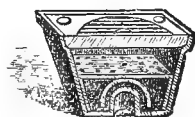

Fig. 162.—The Bell Trap.

sand and gravel find their way into the trap, and provision has to be made for catching these and similar obstructions; this can be done by means of a movable bucket placed at

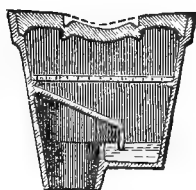
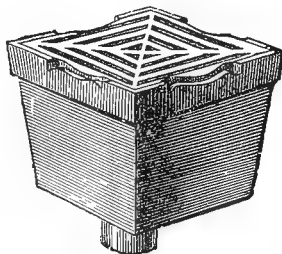

Fig. 163.—Section of a Stable Trap with a Fixed Syphon and Tray.



The Exterior of Fig. 163.

the bottom of the trap, which can be taken out and emptied without interfering with the trapping arrangements. Good specimens of this trap are seen in Figs. 164 and 165.

The ordinary *Gully Trap* (Fig. 166) is an efficient

mechanism for the yard where only rain and yard water enter, but it requires regular cleaning out owing to the amount of sand and gravel which get washed in.

Whatever system of trap is employed in the stable, daily flushing with water is essential; for this purpose pipes should be placed at convenient intervals with a length of hose. Gullies in the yard should also, especially in summer, receive an occasional charge of water to replace that lost by evaporation.

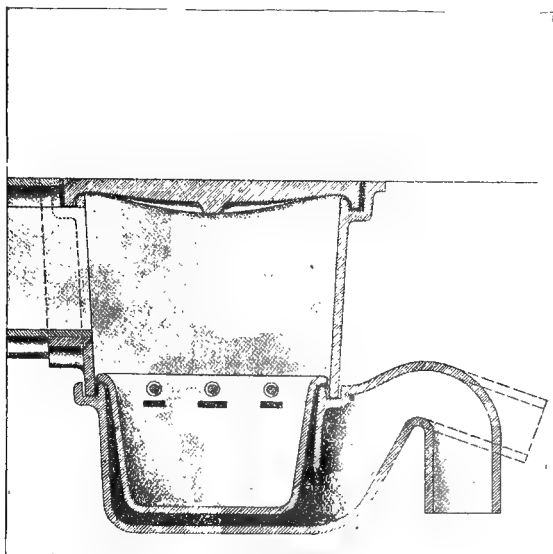

Fig. 164.—Fixed Syphon Stable Trap with removable bucket.

*Cesspits, Liquid Manure Tanks, and Manure Sheds.*—The use of these is imperative in places where no sewerage system exists, but the storing up of decomposing organic matter is a serious question, and one to which the greatest attention must be paid if soil pollution is to be prevented. What we have to arrange for is the collection and storage of all urine and faeces from cow-sheds, stables, piggeries, and straw yards, and for this insanitary proceeding to be carried out on lines which will prove as little hurtful as possible.

We are considering cesspits and liquid manure tanks together, for though known by different names they are identical, one being the farm cesspool, and the other the cesspool of the ordinary residential house. It is with the former that we have to deal and to discuss how it can best be arranged.

The drainage from farm stables, cow-sheds, piggeries, and covered yards, constitute one of the farmer's sources of income. It is imperative in the case of cow-sheds that the drainage shall be on the most approved principles, surface throughout, and no traps of any kind within the building. This is on account of the milk supply, and the facility with which it can become contaminated in a defectively drained place.

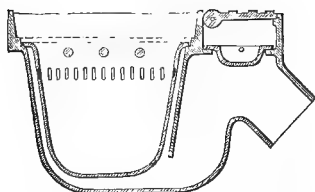

Fig. 165.—Fixed Syphon Trap for Stables, with removable bucket for catching solids.

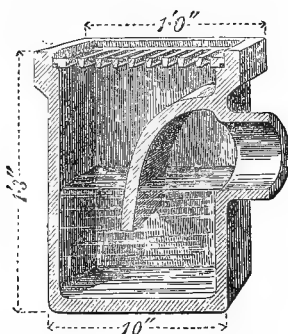

Fig. 166.—A Gully Trap.

The urine in a cow-shed is discharged by the animal practically direct into the surface drain and the bulk of the fæces find their way there also; what fails to reach the drain is swept into it, and the whole contents pass out of the shed into the outside air. It should then pass into a concrete receptacle, 12 feet from the building, one for either side of the byre (Fig. 130), from which it is removed by pumping into the liquid manure cart, and from this deposited either in the covered shed for manure, or discharged into the liquid manure tank.

This carriage by hand may be modified by the cow-shed surface drains opening over a properly trapped drain 12 feet away from the building, and the urine and suspended fæces



being conveyed by underground pipes direct to the liquid manure tank, while the more solid portion of the fæces are removed by hand to the midden.

As previously described there would be no difficulty in having surface drains leading to the manure tank and so getting rid of pipes, but the system would probably be objected to.

In speaking of straw yards (p. 344) it will be remembered that the bottom of the latter is arranged to admit of the percolation of urine, which flows out through an opening specially constructed; this opening should be in communication with the liquid manure tank by means of a pipe.

The usual system of draining stables, cow-sheds, and piggeries into the straw yard is a filthy and insanitary proceeding; it should receive nothing but the urine and fæces deposited there by the animals living in it. One great advantage of a covered yard from the point of view of drainage, is the saving effected in not having to carry off the rain water from the yard, and from the farmer's standpoint this must also be advantageous in not having the soluble portions of a valuable manure washed away.

The liquid manure tank should not be called upon to receive rain water, if this is not saved from the buildings by properly constructed tanks, it should form a separate system of drainage and be passed on to the land. On the other hand the excreta from the occupants of the farm, but not their slop water, may be connected with the liquid manure tank.

The manurial value of slop and waste water is too low to burden the liquid manure tank with it. It should be disposed of on the land, or by pipes laid beneath it so as to be got rid of by subsoil filtration.

The liquid manure tank and midden, or manure heap, are generally placed side by side. The latter should always be placed on an impermeable floor of concrete, with dwarf walls cemented within, and openings at intervals to allow of carts being filled. It is sound economy to place a roofing over the manure heap, it saves the material from rain, and

prevents its most valuable portions being washed out. The brown liquid which trickles from a manure pit is rich in fertilizing matter. The floor of the pit should be so arranged that this material runs into the liquid manure tank, this is easily accomplished by sloping the sides towards the centre and connecting up with a pipe.

It is to be clearly understood that the arrangement of manure pit here described is that for farm purposes only. The pit employed in private stables is simply a temporary resting-place for excreta, which should be regularly emptied every week.

The position of the liquid manure tank—which it will be borne in mind is a cesspool—is one requiring the utmost consideration. It must not be near the dairy or cow-shed, it is equally obvious it must not be near the source of water supply. It ought if possible to be outside the farm premises, at a distance of not less than 30 yards from the nearest building. To reduce labour in the conveyance of excreta by hand to the manure pit, which is situated side by side with the tank, a tram-line should run from the stables and cow-sheds, and at the same time convey from the farm all house and kitchen refuse, which is then deposited on the manure heap and helps to improve the quality of the mass. By means of the tram-line no exception can be taken to this unavoidable insanitary contrivance being placed some little distance from the farm.

A liquid manure tank should be a properly constructed receptacle, the essential feature of which is that it must be absolutely impermeable. Its size must depend upon the number of animals kept; a guide to this daily excretion has previously been given, and the tank may be constructed to hold a four months' output.

Experience shows that from 6 to 7 feet should be the maximum depth, and 6 to 8 feet is a suitable width, while the length may be whatever is desired.

Sometimes two tanks are built, in the first the solid matter becomes deposited, while the liquid passes into the second tank by an overflow pipe.

When the needful excavation has been made, the tank is built of brick in cement; it is next lined with cement, and then nine inches of well-puddled clay placed around and beneath the brickwork. The roof of the tank is arched, provided with inspection manholes, and with proper arrangements for ventilation and disconnection.

In drawing off the contents an ordinary pump may be employed. By the proximity of the tank to the dung pit, some of the material may occasionally be poured over the pit to prevent undue fermentation occurring, as excessive fermentation destroys manure.

The proper conservation of farmyard manure is essentially an agricultural question, but it is desirable that the sanitarian should not lose sight of the necessity for this, as it is economy in the manurial resources of the farm which helps to pay the rent, and cannot therefore be disregarded.

There is always a loss of nitrogen in the manufacture of manure. Even when carefully made, under the most favourable conditions it amounts to 30 per cent. or 40 per cent., and under average conditions 50 per cent.\* Dyer, in the communication previously quoted, places the loss under ordinary circumstances at 23 per cent., and dwells on the importance of placing the manure under cover, recommending a method of protection which is not only simple but highly sanitary. A good bed of dry earth is provided, the manure from fattening boxes or manure pit is placed on this and thoroughly covered with a thick layer of earth, so as to completely confine the ammonia; the mass is kept covered up until required for the land.

*Absorption Method.*—There is a method by which the excreta of cattle and horses could be removed without employing any system of drainage, viz., by absorption with so-called moss litter, viz., peat. Peat has the power of absorbing many times its own weight of urine, and it incorporates with the solid excreta. The system indeed

\* 'Losses in making Farmyard Manure,' Dr. Voelcker and Mr. Bell, *Journal of the Royal Agricultural Society*, vol. lxiii., 1902.

might be made a most perfect one and extremely simple, doing away with drains, traps, and liquid manure tanks; it seems extraordinary it has not been adopted on a large scale.

The question of peat as litter is not here being considered, only its power of taking up urine and mixing with fæces, which forms not only a fertilizer of great value, but is an excellent and sanitary method of dealing with animal excreta. One pound of peat will absorb about 1 gallon of water; it is obvious that for this method to prove successful a sufficient supply of fresh peat should be allowed daily.

*Disposal by Incineration.*—No consideration of the question of the disposal of refuse would be complete without reference to incineration. It is an excellent but expensive system of getting rid of the refuse of large communities. To incinerate the excreta of animals so long as agriculture is practised is a waste of good material, but no hesitation should be experienced in destroying by fire that of animals affected with infectious disease. This, however, comes under the subject of disinfection, and in the chapter dealing with this matter the question will be found fully discussed, and the needful apparatus described.

*Testing Drains and Traps.*—After drains are laid it is well to test them, in fact they should not be covered up until this is done. A simple method is to close the outlet and fill up the pipes with water from the inlet. If, for example, in Fig. 158, D is plugged at its outlet, where it empties into the disconnecting syphon, and the system filled with water until it reaches the grating G, the level of the water should remain unchanged; if it falls there is a leak, which with an uncovered drain is easily seen.

Another method employed is the smoke test, either by means of a specially prepared rocket which emits a dense smoke, or by burning cotton waste in the pipes. If, for instance, the trap F (Fig. 158) require to be tested, smoke generated in B, where it empties into the disconnecting syphon—the grating G being completely closed—would reveal a defect by issuing from the trap in the stable.

Sometimes the test is made more severe by pumping in smoke from a generating apparatus. There are special drain grenades made consisting of a mixture of phosphorus and assafoetida; the grenade is inserted and the drain closed; a little water poured down ignites the phosphorus, and dense fumes with the penetrating odour of assafoetida are given off, the latter if escaping being readily recognised by its smell.

## CHAPTER VII

### SOILS

WE are very deficient in information as to the part played by soils in the production of disease ; at one time the connection between the two was considered undoubted, but little by little as our knowledge has become more exact, the influence of soil has appeared subordinate to other conditions, which though associated with definite geological formations, are yet known to be more important than the soil itself.

For instance, malaria is a term employed by everyone to indicate the existence of a definite form of fever, which was supposed to depend upon certain emanations from the soil. The class of soil where malaria was present, or might be expected to be met with was perfectly well known, and the cause of the disease was pictured as an organic vapour arising out of the earth at certain times of the day.

An immense amount of information was collected from all parts of the world bearing on this question, and gradually it became perfectly well known that low-lying or marshy districts, particularly in the tropics, were malarial, and that altitude gave relative protection.

Wet soils filled with the decomposing vegetable matter of centuries were known to be most malarial ; even disturbing the earth, as in engineering operations, induced malaria by allowing of the escape of the vapours which had hitherto been sealed up, and in other ways the conclusion was irresistibly arrived at that soil of a particular kind and malaria were most intimately connected.

We now know there are no such things as malarial vapours, and that though the above soil conditions associated with malaria still exist, yet they are not the cause of the disease, but only the breeding and feeding ground of the insect that carries the parasite, inoculation with which produces the disorder.

This example of recent research is given as showing how liable one may be, even with moderately exact data, to arrive at a wrong conclusion; it is not the soil but the mosquito which gives fever, but the mosquito requires as its breeding ground a certain kind of soil, and for years that soil has been recognised as unhealthy.

It does, however, appear quite clear that apart from this there are soils which are healthy and others unhealthy, and the chief factor in deciding this point seems to be the question of water in the soil. It is by no means certain how damp buildings and damp soils act, but they seem to lower the general powers of resistance; otherwise it is hardly possible in any other way to account for the reduction in human tuberculosis as the result of draining towns and cities. Respiratory affections and rheumatism are well known to be more prevalent in damp than in dry districts, but why it should be so we are at present in ignorance.

Great stress has in the past been laid on the question of the air in soils, and the rise and fall in the level of the ground water, as being the cause of certain diseases like human enteric; we shall presently study this question and see how it stands, but our object here is to sound a word of warning, and to suggest that unless we are prepared to believe that pathogenic organisms come out of the soil like a dust cloud, we ought to be careful in accepting as evidence of soil implication what may only prove to be one link in the chain of causation.

Pollution of the earth occurs mainly from vegetable débris and the excreta of men and animals; in places like towns and cities where the population is dense the soiling is greatest, in some places, as in the old countries of the world it has been going on for thousands of years, and yet

there is no perceptible increase in the amount as compared with countries which are comparatively new, and this is due to the fact that the soil is capable of regeneration.

In cities the chances of regeneration are more remote, so that in the soil of towns and cities more organic matter is met with as the result of human agency than in country places. Plants by their death and decay contribute to earth pollution, but here again, excepting the material be so excessive that the local conditions cannot cope with it, the remains of the plants are gradually by the earth's process of self-purification removed.

A study of soils is of greater value to the agriculturist than to the physician, there is no mistaking the part they play in the growth of the plant, and from a veterinary point of view soils are of much more interest to us agriculturally than pathologically. The one aspect is definite and intimately connected with the welfare of animals, the other is to some extent doubtful, though there are of course conditions of soil which are undeniably connected with health.

*Soils, Geologically.*—The interior of the earth is composed of rocks which may broadly be divided into two great groups, those arranged in layers known as stratified, and those which present no stratification. Stratified rocks from their having been built up in successive layers under water are sometimes known as aqueous, while the non-stratified, which have resulted from the cooling down of what was originally molten material, are sometimes known as igneous. A familiar example of the latter is granite, and of the former sandstone.

The study of geology reveals that the stratified group of rocks are capable of being classified according to their age and distinctive characters; we cannot attempt here to deal with this question even in outline, our main point is comprised in the statement that no matter what the nature of the rock may be, the crust of the earth or soil is entirely derived from the rock beneath, so that soils are regarded as rocks which have worn down or otherwise become disintegrated, or as the geologist terms it, 'weathered.'



The chief causes of the wearing of rocks are exposure to air, heat, cold, rain, and frost, extending over immense periods of time. We may even see the effects of these disintegrating forces in the stone employed for building purposes.

The soil, therefore, as a rule partakes of the nature of the rock it covers, but there are exceptions as in the alluvial soils brought down by big rivers like the Nile, Ganges, and Amazon; which overlay the natural rock of the part, and bear no relation to it. Such are spoken of as soils of transport.

Ordinary soil is a mixture of sand, clay and lime, with a variable proportion of saline and organic matter. The difference in soils depends upon the relative proportion of these constituents, while its fertility, within certain limits, is affected by the proportion of humus and inorganic matter present.

Sand by itself is of no agricultural value, it would neither afford support for the roots of plants nor sufficient moisture, but it confers a certain property on soils when mixed with them, viz., lightness, and it opens them for the admission of both air and moisture.

Clay in a pure condition is of no agricultural value, as a matter of fact it is seldom pure, but the point to be noticed here is not its fertility but its physical function in the soil. It is plastic, retentive of moisture, and consequently cold; it is the exact antithesis of sand in these respects. The admixture of clay with sand causes the latter to retain its moisture and gives it tenacity, while the sand raises the temperature of the clay, opens it out, and renders the soil more porous.

When clay and sand exist together in a soil in moderately definite proportions they form what is known as a *loam*; if the percentage of sand exceeds that of the clay it is known as a *sandy loam*; if the clay is in excess it is called a *clay loam*; when neither one nor the other are greatly in excess it is termed a *loam*.

The function of these two important soil constituents is

to give porosity and adhesiveness, but to fully bring this about the clay must be in a flocculated condition, or it would impair the porosity of the soil. This flocculated condition is brought about by the mixture of lime with clay which produces a marl; such clay is no longer impervious to water, while by mixing with sand it produces a granular state of soil.

A *marl* is a clay containing from 5 to 20 per cent. of lime carbonate; if the lime is in excess of this the soil is termed *calcareous*, while sand containing lime is called a *calcarene*.

A soil to be fertile requires something more than these. The mould such as is seen in a garden is a loam, but its dark colour is due to a substance known as humus.

*Humus* is the bacterial outcome of the decay of animal and vegetable matter in the soil, it is brown or even black in colour, and chemically is very complex, consisting, among other things, of certain acids of which humic and ulmic are best known.

An excess of humus in a soil is a serious matter, such soils are practically infertile, for example, peaty and boggy soils, in which the humus exists in considerable quantity. This is due, among other causes, to the liberation of the above acids under the influence of the water in the soil. The soil becomes too acid for anything but a poor form of shallow-rooted vegetation, such as sedges, rushes, mat grass, Yorkshire fog, etc., but in moderate amounts, 2 to 9 per cent., the humus in a soil carries material easily capable of being converted into plant food, while if the amount of natural humus in the land gives an indication of failing, the farmer replaces it in the form of manure.

Soils consist of both an organic and inorganic portion, and from both of these the plant derives its food supply. In all cases the plant food must be in solution, hence water in the soil plays an important part as also do certain micro-organisms, the function of which is to render the nitrogen of the soil soluble.

The considerable differences which various soils present depend entirely on the relative proportions in which the sand,

clay, lime, organic matter, and salts are represented, and this is true of colour as well of the other physical conditions.

*The soil is constantly changing*, it loses water by direct evaporation, evaporation from plants, also by drainage. The water passing through a soil carries the soluble salts with it, some of which like the nitrates are of the utmost importance, as being the form in which the plant assimilates nitrogen. The soil gains material from the atmosphere, both nitrogen, carbonic acid, and water, and is enriched by the residue of crops and manures.

Besides these there are gradual changes taking place in soil; it is a well-known fact that the most carefully selected grass seeds may fail to produce a luxuriant growth on certain soils, until with the lapse of years these slow changes have become accomplished.

In the production of changes the part played by the earthworm must not be overlooked, it gradually reduces the soil to a finer condition through the earth which it ejects as castings; it enriches the soil with nitrogen, and by its physical effect keeps it open for the penetration of both rain and air. It was calculated by Darwin that on an ordinary pasture, the whole of the fine surface soil to a depth of ten inches was passed through worms and turned up in the course of fifty years.

*Ground Water.*—The water in the soil is known as the ground water; its level varies with the rainfall and with different soils; it may be at the surface as in the case of marshes, or many feet below as in the case of deep wells. A ground water 5 feet from the surface is too high for health; 15 feet is a common and safe depth. The ground water is the residue of that which has fallen on the earth, it is constantly seeking its natural outlet into streams and rivers, so that it is always in motion. Its height is determined by the height of the water in neighbouring wells, and fluctuations in its height have been connected with the onset of disease, especially by Pettenkofer, who was the first to direct attention to the question.

In addition to the ground water there is always moisture

in the superficial layers of the soil, which is obtained from the ground water by means of capillary attraction. One function of sand in a soil is to open up the earth so that this capillarity may occur.

A great deal has been written on the subject of ground water and disease. It is undoubted that if the ground water is near the surface such sites are not healthy, they are damp, and damp soils have a deleterious effect on the general health of man and animals. But it is difficult to understand how the fluctuations of the ground water can be held responsible for the production of such diseases as enteric or cholera, and the general opinion now appears to be against their having any such influence.

If, for instance, we take three diseases, cholera, anthrax, and South African 'Horse-Sickness,' all intimately associated with rainfall, it by no means follows that because the ground water fluctuates that this is the cause of the trouble. It would be as reasonable to say that because the rivers are running fuller cholera and anthrax break out. In both cases the rise of the ground water, and the increased volume of water in rivers, merely indicate a recent rainfall.

Certainly so far as anthrax and African 'Horse-Sickness' are concerned, we must look for some other condition associated with rainfall, rather than the obvious one of a rise in the level of the ground water.

It was supposed that as the result of the rise of the ground water, the air which would be thus driven out of the soil contained emanations deleterious to health, while at the same time substances got washed into the wells, the result of the rainfall percolating through the earth, and this was held to be sufficient to account for cholera and enteric, but the evidence is not convincing.

*Air in the Soil.*—All soils excepting the densest rocks contain air, as much as 50 per cent. may be found in loose sands. The gases found are oxygen, nitrogen, and carbonic acid, the latter being in much greater portion than that of the atmosphere, in fact two hundred and fifty times

greater. There are annual and seasonal fluctuations of the carbonic acid in the soil, and larger amounts are found in the deeper than in the surface layers. As water passes through the soil it takes up carbonic acid, and as noticed at p. 3, this is one of the causes of the wearing away of certain rocks by the solvent action of the acid.

The oxygen in the soil air diminishes as the deeper layers are reached, until finally it ceases to exist. This fact has an important practical bearing on the disposal of the dead by burial, especially animals which have died from infectious diseases. The anthrax bacillus, for example, cannot sporulate excepting in the presence of free oxygen, so that deep burial is a safe method of disposing of these cases.

The nitrogen in the soil air is much the same as that in the atmospheric air. If plants could utilize the nitrogen of the air agriculture would be greatly simplified; with a few exceptions they cannot. The exceptions are certain leguminous crops in which nodules form on the roots; these nodules contain organisms which are capable of utilizing free nitrogen as plant food. To these organisms the name *Bacillus radicicola* is given; it is found that though in appearance they cannot be distinguished from each other, yet, stating the case broadly, each leguminous plant has its own organism, so that, for example, the organisms of the pea are of no use for the clover.

The movement of the soil air is a process constantly occurring more or less freely, depending upon the porosity and dryness of the soil. The actual motive power is furnished by the rise and fall of the ground water, as the water rises the air is forced out, as it sinks the air is drawn in. It is during the rise of the ground water that soil emanations are forced out, and where the surface pollution is great, as in the neighbourhood of inhabited buildings, these emanations must be a means of rendering the air impure.

This is the reason for the necessity of paving in and around buildings, and placing them on an impervious

foundation such as concrete. A building owing to its higher temperature acts as a suction pump to the soil on which it stands, and impurities both from below and laterally may be drawn in.

This is particularly the case in the matter of 'made soils' such as are frequently met with in towns and cities. A made soil is produced by filling in excavations, or levelling uneven ground, with the rubbish of the neighbourhood. Practically anything and everything is employed for this purpose, the land being afterwards used for building purposes. Observations have shown that it takes at least three years for most animal and vegetable débris to disappear in the soil.

*Soil Temperature.*—There are some soils like sand which are hot, others like clay which are cold. Soil temperature depends upon the capability of the soil for absorbing heat. The power of the soil to absorb heat depends largely on its colour, being least for light-coloured soils, and greatest for dark soils. In the deep layers of the soil the heat penetrates slowly, so much so that it may be many weeks after the maximum temperature of the air has been reached, before that of the deep layers of the soil is arrived at. There is a daily and an annual variation of soil temperature, the former in the United Kingdom cannot be determined at a greater depth than 4 feet, while the annual variation ceases to be felt at 40 feet from the surface. Below 40 feet the temperature of the soil increases 1° Fahrenheit for every additional 50 feet of depth.

The radiation of heat from soils depends to an extent on their capacity for absorbing it, but also on their colour and the degree of vegetation covering it. The more vegetation the more rapid the cooling; the darker the soil the longer it holds its heat. Soils, however, always cool quicker than they heat. The colour of dark soils is due to humus, while the red, yellow, and brown soils are coloured by ferric oxide.

*The Micro-organisms found in the Soil* have been the subject of considerable research. Some of them of service to

agriculture are here alluded to. The important *nitrifying ferment* is found in the superficial layers of the soil, it consists of two distinct species, one converting the ammonia of the organic matter into nitrous acid, while the other converts nitrous into nitric acid.

In both cases these acids unite at once with alkalies to form salts; the alkali generally selected is lime, so that calcium nitrate is the final product, this is readily soluble in water, and is the form in which nitrogen is taken up by plants.

This nitrifying process in soils is one of purification as well as providing plants with nitrogen. The nitrogenous organic matter, that is, the nitrogen combined with carbon, cannot be utilized by plants until it has undergone the process of nitrification; the first step in this is the breaking up under bacterial action of the nitrogen into ammonia, and the carbon into carbonic acid. The ammonia is then seized upon by the nitrifying ferments, and as above described, converted into nitric acid.

In this way soils get rid of both animal and vegetable matter, and a process of self-purification of the utmost utility occurs. It will be remembered that similar changes occur in the bacterial disposal of sewage.

In this nitrifying process, it will be observed, the nitrogen for the plant begins as nitrates and ends as nitrates. As soluble nitrate it is taken up by the plant and converted into albumin; in the animal body the plant albumin is converted into animal albumin, its ultimate decomposition product being ammonia. The ammonia in the earth is seized upon by the nitrifying ferments and converted into nitrites, and finally into nitrates, thus completing the cycle of changes.

Nitrification requires a porous soil, and the free access of oxygen is essential to the process. A certain temperature is also necessary, so that during winter it is practically in abeyance, while it is active during summer. Too much water in the soil is detrimental, as this means the exclusion of the necessary oxygen. Nitrifying bacteria are not found

at any distance below the superficial layers of the soil, which explains the sterile nature of the subsoil.

Organisms which produce *Denitrification* are also known. They result in the formation of gaseous nitrogen from nitrates, ammonia, or organic compounds of nitrogen, and this nitrogen is lost to the plant.

Other organisms in the soil useful in agriculture, are those previously alluded to as forming nodules on the roots of certain leguminous plants, which enables them to utilize the free nitrogen of the air.

In the examination of soils for micro-organisms, it has been found that few if any exist at a depth of 12 to 15 feet from the ground, while from the surface of the ground to a foot below, they are said to increase in number.

Of *Pathogenic Organisms* there are two which belong to the soil proper, viz., that of tetanus and malignant œdema. Of organisms which do not belong to the soil, yet readily flourish in, or at least are not killed by lying in the earth, are anthrax, quarter-evil, and braxy in animals, enteric, plague, and cholera in man.

The various forms of fever known as malarial are in the light of recent researches not soil diseases, but the result of infection by insects the natural habitat of which is the soil. The same perhaps may be said of African Horse Sickness. It is probable that neither rain nor soil play any other part in the production of these diseases than in forming a suitable medium for the support of some blood-sucking insect that is the means of inoculation.

Soil diseases play a less important part in pathology than was at one time believed; miasma is a thing of the past, and there are no poisonous malarial vapours; there are soils which we know to be dangerous, not on account of emanations from them, but because they form the home of insect pests capable of producing disease, and in this group may be included the malarial and yellow fever mosquito, and the blood-sucking fly which produces 'Tsetse' disease, and allied diseases of the human subject.

*Tetanus*.—It is clearly proved that the organism which



produces tetanus lives in the soil, and from the fact of it being an anaerobic parasite it would appear to develop at some distance from the surface. The liability of equines to tetanus may depend entirely on the greater facilities for infection from the soil—as, for example, in wounds of the feet—than exists in man. We do not believe, as is asserted by medical writers, that it was originally a disease of the horse, but there is no difficulty in understanding the greater liability of equines to infection.

*Malignant Œdema.*—The bacillus of this disease is readily isolated from garden mould. It produces a fatal disease in guinea-pigs, rabbits, and mice, and has been observed in the human subject, after compound fractures, accompanied by a rapidly spreading œdema with emphysema of the tissues. The same condition may occur in the horse following castration.

*Anthrax* is generally regarded as a soil disease, but it can only be so in the sense that the soil receives the germs from a previous case, either by the death of the animal, or by spores being carried on to the land during floods, and in other ways.

It is quite true that certain lands possess an unenviable notoriety for producing anthrax, but that is only as the result of previous or persistent infection. It is not a soil disease, but the organism can live and multiply in the soil as apart from the animal body, provided the needful temperature, moisture, and oxygen are available. In this way pastures become infected from the blood or discharges of previous cases, and there is evidence to show that the infection may remain very persistent. This question will be referred to again in the chapter dealing with the eradication of infectious diseases.

*Quarter-Evil* is another affection intimately connected with certain pastures, for fuller information on which the section dealing with this disease should be consulted.

*Epizootic Lymphangitis* in horses is mentioned in connection with soil diseases, as it is probable soil infection is a common cause of inoculation. We do not know whether

the organism belongs to the soil, but there is evidence to show that soil infection is one of the means by which the disease spreads.

Soil infection in *Epizootic Abortion*, *Navel-ill*, *Influenza*, and *White Scour* must not be forgotten, for which see the section dealing with these diseases.

*Fluke disease*, especially of sheep, is known to be associated with certain moist pastures, not because the land is marshy, but for the reason that this class of soil furnishes a suitable nidus for the support of the intermediate host, which is a species of fresh-water snail. Fluke disease and its preventive measures will be considered later, but as it is intimately connected with the draining of the soil, we may conveniently consider this latter question here.

*Draining Soil.*—We have stated that it is not possible to exactly define why damp soils are unhealthy excepting on the obvious explanation that they are wet. This takes us no further, unless it can be shown that a damp soil favours the organism of tuberculosis or the poison of rheumatism. Everyday observation tells us how intimately wet and dry soils are associated with health, and for the present we must be content to accept the facts without explaining them.

Animal life is not the only one affected by wet soils, only the poorer crops are produced when land requires draining, while weeds become abundant, and the ranker and coarser grasses flourish and take the place of good ones. Such land is cold owing to its contained water, and the nitrifying ferments are either destroyed or are only capable of imperfect work.

Under these circumstances the land is drained so that the ground water may be lowered by running away. The amount of drainage required depends on the character of the soil, a clay obviously requiring more drainage than a light soil. Drainage also may be shallow or deep; as a rule, shallow drainage at a depth of about 3 feet from the surface is adopted. To accomplish this trenches are dug according to the slope of the ground, and at a

distance of about 20 feet apart. Unglazed, that is porous, earthenware pipes are used without any collar, but simply placed end to end; through these joints and through the earthenware the water finds its way to the outlets. These latter are arranged at a slightly greater depth than the furrow drains, and should be as few as possible, it being better for the furrow drains to collect into one main drain and for this to have one outlet. There are different methods of laying these drains, but the above gives a general idea of the process.

Besides drains the ordinary watercourses should be attended to, ditches cleaned and opened, outfalls kept in order, and obstructions removed from streams and rivers.

Such is the ordinary course of procedure adopted to lower the ground water, no matter whether it be fluke disease, foot rot, anthrax, quarter-evil, or other disease associated with wet soils with which we have to deal, or whether the object of the drainage is simply to convert a damp into a dry site. In all cases perhaps it is well to give the land a dressing with lime to get rid of the acid, and to encourage the proper soil ferments; this dressing should also not be neglected in disease, the utility of lime is well known as a dressing for 'fluky' pastures.

*Selection of Site.*—In selecting a site for buildings, or a healthy place for animals, we must endeavour to get them on high ground out of which there is drainage and into which there is none. To select soils permeable to air and water, and with a naturally low level of ground water. To avoid low-lying or marshy districts, valleys or river courses, to keep off alluvial soil, and in towns and cities to avoid those which are known as 'made soils.'

The soil of a southerly aspect on the slope of a hill is always warmer than that on a northerly aspect.

CHAPTER VIII  
DISINFECTION

ONE of the most important means at our control for the eradication of specific disease is disinfection. By means of suitable disinfectants we may make positively certain the excretions of the sick are so acted upon as to be rendered harmless; that everything which has been in contact with the patient has been so treated as to be unable to convey disease, and the building occupied by the diseased cases dealt with in such a way that healthy animals can be placed in it without fear of infection.

Disinfection gives us a sense of security obtained in no other way; it is quite true there are some diseases where the infective material does not live long apart from the animal body, but there are others where its vitality is remarkable, and it is obvious that to trust to time alone for destroying infection, is both unwise and illogical, when the same end can be obtained in the short space of a few hours.

*Principles of Disinfection.*—A disinfectant is an agent either chemical or physical which destroys pathogenic matter; its destructive action may be required for the eggs of a parasite, or for the remarkably resistant spores of a bacillus. In either case the principle involved is the same, though the selection of the particular disinfectant depends to an extent on the nature of the virus it is intended to destroy.

There are disease germs which offer little opposition to the action of disinfectants, and others which are most

obstinate. The disinfecting agent for the one is unsuitable for the other, so that some selection is necessary in the matter, and this selection is based on experimental enquiry.

In judging of the value of a disinfectant experimentally, it is usual to select the most resistant organism known, viz. anthrax rods with and without spores, and expose them to the action of the substance, determining from time to time by inoculations on a susceptible animal whether the organism is dead or not. In this way a deal of exact knowledge has been obtained, and the fallacy of using certain popular disinfectants has been exposed.

Experiments conducted on these lines have demonstrated what strength of disinfectant should be employed, and for how long its action should continue; in other words, the subject has been reduced to a degree of exactitude quite unknown a decade ago.

The strength of a disinfectant is a most important point; sufficient may be added to a diseased fluid or substance to control or prevent the growth of the organism, and yet insufficient to kill it. Disinfection that does not kill is of no use.

Again, it is sometimes believed that where disease poisons are associated with organic matter in a state of putrefaction, or emitting foul smelling gases, the mere destruction of the latter ensure the death of the former. But this is not so, a deodorizer is by no means necessarily a disinfectant.

The most perfect disinfectant is of no use in unskilled hands, for disinfection to be effective must be complete and thorough. It is no use disinfecting the walls of a stable and leaving the mangers untouched, nor of thoroughly doing the stable and omitting to destroy the bedding; while disinfecting the mangers within and neglecting to do the outside can only lead to disappointment. Disinfection to be thorough must be carried out under expert supervision, by one who knows where danger lurks, where to look for it, and brings that skilled and special knowledge to bear which can only be obtained by an intimate acquaintance

with disease, and a knowledge of the habits of animals. This is why disinfection in the hands of a layman is as incomplete as it is perfunctory, for the reason that the word 'thoroughness' is not understood.

Take a very common example, the disinfection of premises after an outbreak of swine fever, what are the special points which here require attention in addition to the obvious one of disinfecting the piggery? The special points are the disinfection of the entire ground to which the pigs have had access; the collection of all excreta, the filling in and disinfection of puddles, the entire destruction of all manure heaps and food which has been in contact; the disinfection of trees, posts, boulders, hurdles, ropes, nets, carts, or anything else with which swine would commonly come in contact, treating each and all of these as if they were as infective as the animal itself.

Such disinfection is thorough, and should leave the place after sufficient time has elapsed as secure as before infection. It is not possible for a layman, unless carefully trained, to carry out effectively such a system, which though simple in itself depends for its effectiveness on attention to detail. He does not realize how many hundreds of disease organisms may comfortably occupy the eye of a needle, and a splash with a lime-wash brush according to his views meets the entire case. It is here that disinfection commonly fails, it is seldom thorough.

The extent to which disinfection is carried largely depends on the character of the disease; in the example selected of a highly infectious form of fever in the pig, we know that the poison is liberally distributed by means of the discharge from the bowel. Where animals are at liberty to roam the infected area may not only be considerable, but the evacuations are means of distributing the poison over substances and material that are not generally regarded as having much to do with pigs.

And this is where the expert comes in, he knows that the chief danger from glanders, for example, lies in the nasal discharge, and his experience tells him that the wall in

front of the manger, the manger itself, stall partitions, ground and bedding, are vital points to attend to. If buckets have been used in the stable for watering from he realizes the risk, if watering has been done from a trough he knows the damage is already probably done, but he treats the trough as a suspect and deals with it accordingly. Even this thoroughness will avail little if the nose bag be forgotten, or the sponge or rubbers used in grooming neglected.

Comparing these two examples, we observe that while in the one case the greatest care is taken in disinfecting every place which the discharge from the bowels could possibly contaminate, in the other the chief attention is directed to those places likely to be infected by the discharge from the nose.

Take another example, and this time from a place where the contagion does not come from within but from without, viz. scabies in horses.

Here the expert knows that those things immediately in contact with the surface of the body are the most dangerous; for example, saddle or harness, clothing, grooming gear, and bedding. He realizes that every place where the patient may have rubbed is probably infected, and directs his special attention to the stall and its fittings.

In order then to be able to disinfect thoroughly, the nature and character of the disease must be understood, and a knowledge of the resistance likely to be offered by the microbe to destruction is essential. Neither a pleuropneumonic nor a tuberculous patient are likely to affect the ground it walks over, whereas one with foot and mouth disease certainly will. While no harm is likely to arise from failing to destroy food which has been in contact with an animal suffering from anthrax or quarter-evil, in the case of foot and mouth disease and rinderpest it will certainly cause the disease to spread. While the blood of a patient destroyed for tuberculosis might be left on the ground without the slightest harm following, that of anthrax if so left will certainly spread the disease.

These examples are only given as illustrating the case in point, viz. if thoroughness of disinfection is to be carried out it must be done under competent direction. The supervising authority should know something of the vitality and life history of the organism he is endeavouring to exterminate, he must know its favourite habitats, he must fully realize its extreme minuteness, and that an undisinfected patch, impossible to see with the unaided eye, may contain sufficient of the poison to start the whole disease afresh.

We have dwelt on this question, as it is important the public should understand when it is paying money to exterminate disease, that the destruction of the affected is only the first step towards that end; the next, and equally important, is thorough disinfection. The latter is usually left to lay control, with the result that it is imperfectly performed in consequence of ignorance. It is just as necessary for thorough disinfection as for accuracy in diagnosis that the expert should be employed, otherwise compensation may be a waste of public money.

The material against which disinfection is directed is living matter, generally very minute, so much so that even with the highest powers of the microscope it has not yet been seen for some of the most infectious diseases.

The difficulty attending disinfection in lay hands is due to the extremely minute size of most pathogenic organisms, such as the untrained mind is quite unable to grasp. It cannot realize that a blade of grass may have on it sufficient virus to infect a whole herd or flock, or that a neglected corner of a pig sty, easily covered with the tip of the finger, may be the means of starting swine fever among a previously healthy batch of pigs.

*Disinfectants* are chosen from two groups either chemical or physical, the latter being heat in some form or other. Chemical disinfectants are a large group consisting principally of acids, salts, and gases.

*Disinfection by acids* need not occupy us; with strong acids like nitric, sulphuric, etc., it is very complete, but the



corrosive nature of these acids renders them unsuitable for disinfecting purposes, and they are also very expensive.

Chlorine, iodine, and bromine, are well-known disinfectants, of which chlorine is the only one in general use, the others being far too expensive. The free gas may be employed or the gas held in lime; this brings us to a consideration of the question of fumigation, which may here be conveniently dealt with.

*Fumigation.*—In days gone by when diseases were believed to be due to something in the air, and the sick were supposed to give off emanations from the body which poisoned the surrounding atmosphere and the contents of the stable or room, it was a very rational method to meet this state of affairs by generating a gaseous disinfectant. But fumigation, though still practised, now holds a very subordinate position, for the reason that pathogenic organisms do not float in the air unless in a dry condition, but prefer to adhere to substances such as walls, woodwork, stable fittings, flooring, etc. Therefore, instead of trusting to the action of a gaseous disinfectant, we prefer to at once deal with the infected surface by applying the disinfectant directly to it.

Experimental enquiry shows how extremely difficult it is to kill pathogenic organisms in buildings by aerial disinfection only. The gas to be of any use as a destroyer must exist in a certain percentage for a definite period, and this is most difficult to maintain. Even with every care in papering up and closing all openings, cracks, windows, ventilators, air bricks, etc., there are still sure to be unobserved sources of leakage, which prevent the gas being kept at the percentage amount requisite for disinfection. It is impossible to hermetically seal the building, and without this fumigation is of little use.

There is no objection to fumigating a building as part of the disinfecting programme, but by itself it must not be trusted to or it will certainly fail.

*Chlorine* gas is heavy and diffuses badly, if employed as a fumigant it should be generated in several parts of the

building, and placed at some height above the floor. It may be conveniently generated by acting on bleaching powder with sulphuric acid; for every 1000 cubic feet of space  $1\frac{1}{2}$  lb. of bleaching powder and 6 oz. of commercial sulphuric acid are required. Disinfection by chlorine in a dry atmosphere is most uncertain; care should be taken before starting fumigation to wet the walls and fittings with water, in order to ensure the action of the gas, which must be continued for several hours.

Chlorine may be more effectually employed in solution, 8 ozs. of bleaching powder to 1 gallon of water. The walls, stable fittings, and flooring, thoroughly washed with a *fresh* solution of this substance may be considered moderately safe, though it is recommended that two or three washings should be given to ensure absolute destruction.

Washing with chloride of lime water is here recommended, for the reason that it is a disinfectant readily obtained, and undoubtedly of great value if made from *fresh* material, and used when made. It should also enter into the ordinary discipline of stable and cow-shed cleaning, not once a year but once a week. It is not, of course, necessary, except in cases of disease, that the whole place should be done out weekly, but the walls over and under the mangers, the flooring, and fittings might, especially in the case of industrial stables and cow-sheds, receive a weekly washing, and this is best effected by doing a certain amount every day.

This should be the system in all veterinary hospitals, and for this purpose a small staff should exist, the duty of which is to carry out the daily disinfection of a part of the hospital, the system being so arranged that the disinfection of each place is carried out weekly.

*Sulphur* as *sulphurous acid* has been a popular disinfectant for many years, but it is unnecessary to consider it here, as experimental enquiry has shown that it is a very uncertain and very inferior agent for this purpose.

*Mercuric Chloride* stands at the head of all disinfectants for certainty and reliability. A solution of 1 to 1000 in

water destroys the bacilli of glanders and anthrax in ten seconds, and the spores of the latter in ten minutes. As anthrax spores are the most difficult organisms to destroy, we may accept the fact that a solution of mercuric chloride is the most powerful disinfectant known.

It has certain disadvantages in being highly poisonous and most destructive of metal work, and these two considerations greatly limit its use, especially where large surfaces are concerned. Further, by its coagulative effect on albumin a protecting surface is formed which prevents the disinfectant penetrating, so that in the case of an albuminous substance, like phthisical sputum, it is said that even in the strength of 1 to 500 it is ineffective, owing to the coating formed around the bacilli. A solution 1 to 1000, well mixed with the sputum, has been found to be a disinfectant after being in contact not less than twelve hours.

If mercuric chloride be employed in bulk it should be coloured to prevent accident, as the solution is quite colourless. It is usual to add aniline blue to it as a precautionary measure.

*Carbolic Acid.*—This held undisputed sway as a disinfectant until the discovery of mercuric chloride, and it is still a disinfectant of the utmost utility and value. The chief thing in employing carbolic acid is to use it strong enough, only a certain amount is soluble in water; a saturated solution of the pure crystals gives a solution containing 8·6 per cent. of phenol, but the impure acid sold for disinfecting purposes is by no means so soluble; this is owing to the tar oils it contains, and it is believed that these latter are without any disinfecting properties. A saturated solution of ordinary impure carbolic acid only yields 3·5 per cent. of phenol, which is less than is necessary for the destruction of the spores of resisting microbes. This point should be borne in mind in dealing with anthrax or tuberculosis.

Carbolic disinfecting powders prepared with lime are of no value. Calvert's and Macdougall's are both without lime as a basis, and are satisfactory.

In the use of carbolic acid, as with sublimate, a sufficiency must be added; for instance, if a fluid is being disinfected it is no use to add a 5 per cent. solution to it and expect disinfection. The fluid to be disinfected must contain 5 per cent. of the acid in order that destruction may occur.

The difficulty in obtaining a sufficiently high percentage of impure carbolic acid in solution, may be got over by the use of *cresol* or *lysol*, both of which mix with water in any proportion; it is said that a 2 per cent. solution of the latter is equal to 5 per cent. of carbolic acid.

*Izal* is a disinfectant well spoken of, and experimentally has yielded very good results. It mixes readily with water forming an emulsion. In a 10 per cent. solution Notter\* found it destroyed the spores of anthrax in twenty minutes, while the rods were destroyed after five minutes' exposure to a 0.5 per cent. solution: it further has the advantage of being non-poisonous. It is considered that exposure to a 1 per cent. solution for fifteen minutes will be sufficient for all ordinary cases of infectious disease.

No dependence can be placed on the disinfecting properties of either zinc chloride, or iron sulphate; a solution of the former was at one time in great request.

*Caustic lime* is largely used as a disinfectant for stables and cow-houses; in the caustic state it may be of some use, but as whitewash plastered on indiscriminately, it is simply covering up the pathogenic matter. Limewash is not without its utility in its proper place, as will be indicated later, but it is not a disinfectant in the sense in which we have been considering this question. Whitewash, which is limewash minus its caustic action, is utterly useless.

*Disinfection by Heat.*—The practical application of heat as a disinfectant is somewhat different to that employed in human hygiene. In the latter chambers are constructed for dry heat, moist heat, or for sterilizing by steam, but these are adopted for the reason that people are loathe to part with their dresses, furs, underclothing, feathers, bedding, blankets, etc., so that some method, not always satis-

\* 'Theory and Practice of Hygiene,' Notter and Firth.

factory, has to be employed for their disinfection. As a matter of fact it is found from experience that these articles are most difficult of disinfection at any temperature short of damaging them, for heat penetrates textile fabrics very imperfectly.

In veterinary hygiene we can employ heat, but ovens are unnecessary. Walls can be burned or clothing boiled, and this is the only disinfection by heat which we shall consider.

Nothing can approach fire as a thorough disinfectant, and in dealing with an outbreak of infectious disease the destruction of the bedding and contents of manure heap by setting fire to them, is one of the earliest things done. While this is in progress all metal work used in the stable, buckets, pitchforks, shovels, etc., may be passed through the flames.

Fire can with care be generated in the stable, a certain amount of the bedding being strewn on the floor and set fire to. This can be done a stall or two at a time, excepting in those cases where wooden stall partitions exist. In industrial and army stables where the fittings are iron, no danger whatever need be apprehended from this measure, if conducted with very ordinary care.

Fire can be applied to all iron work and brick walls, either by means of a plumber's or painter's lamp, or, if gas exists in the stable by using it through a singeing machine. If the flame be passed over every portion of the iron work, brick, and plaster of the stable, absolute safety is ensured.

Even with woodwork it could be done with the best results, and practically no risk, for no charring is required, and in the case of paint work it simply blisters the surface, which can be easily restored; in fact, it is the method the painter himself uses in order to take the paint off.

With care, then, practically very little in a stable need escape the action of heat, and no elaborate apparatus is required.

Heat may be applied in the form of boiling water, but this is less reliable as the temperature of the water soon

falls, and the difficulty of ensuring that absolutely boiling water is employed is considerable. Still, as a means of washing out mangers and flooring it is not without value.

For the disinfection of clothing boiling may be used with advantage, but where many blankets have to be done it is a slow process, and if the latter are of wool they are ruined. We shall presently consider how blankets may be disinfected on a large scale.

*Method of Applying Disinfecting Solutions.*—The best method of applying disinfecting fluids to stables and stable fittings is by means of a fine spray. It is vastly superior to a brush, for the spray may be made to penetrate by the force of the pump, while the area dealt with at one time is very much greater than could possibly be reached by hand.

Apart from these considerations, the spray may be made to penetrate into corners where a brush could only be introduced with difficulty, and it is in corners, on projecting surfaces, lips, and other irregularities where dust lodges, and with the dust in all probability are the pathogenic organisms we are in search of.

The walls, ceiling, floors, every part of the fittings of stables or cow-houses can be reached by a spray pump with the utmost ease and rapidity, and no other system can compare with it for effectiveness and thoroughness.

Spray pumps may be had either to deliver the disinfectant from an ordinary bucket, or attached to a barrel cart which can be wheeled about, and holds 50 gallons of disinfectant. Figs. 167 and 169 show two patterns of these pumps, while the spraying nozzle, which is the essential feature, is shown in Fig. 168.

Limewashing may also be done by a spray pump, thereby saving considerable labour and time. Fig. 170 shows an apparatus for this purpose.

Spraying may be adopted in dressing cases of contagious skin disease, or for removing ticks from animals. For the latter purpose a mixture of kerosene and water is employed, delivered by a pump to which is attached a kerosene chamber ;

the proportion of oil is controlled by means of a valve in the kerosene chamber, and the desired percentage of oil is



Fig. 167.—Spray Pump, small size, arranged to work from a bucket (Deming Co.).



Fig. 168.—The Spray Nozzle, adjustable to any degree of fineness, and throwing a fine mist-like spray.

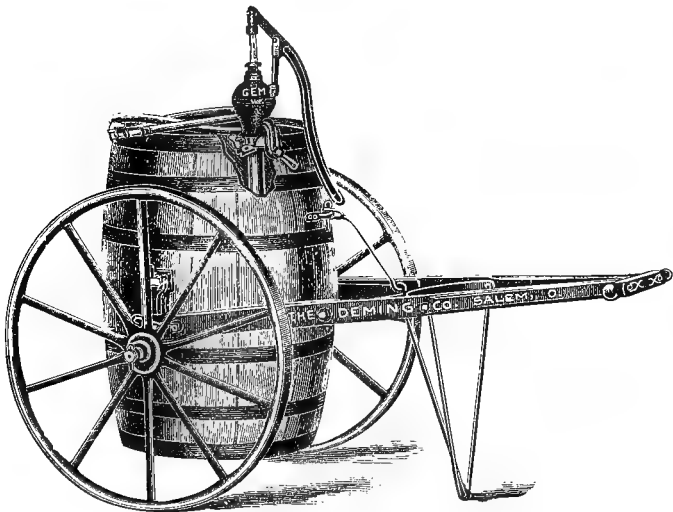

Fig. 169.—Spray Pump, arranged on barrel cart, for disinfecting.

indicated on a dial. The kerosene is mechanically mixed with the water during the process of pumping.

We have now reached a point at which it is convenient to consider how we should set to work to systematically disinfect a stable or cow-shed.

*Routine of Disinfection.*—The first step is the brushing down of the walls, windows, etc., so as to remove the cover of dust. If the walls are not burned as previously described, the limewash should be scraped off from top to bottom. Plaster must also be scraped, but tiles or cement need not be. The walls having been dealt with, the mangers and fittings must next occupy attention. If of iron, they can be burned in the manner before described, or washed with



Fig. 170.—Spray Pump, arranged for either disinfecting or limewashing.

boiling water, soft soap, and carbolic acid, a brush with a handle being used to admit of this being placed on as hot as possible. Wooden mangers, bails, posts, etc., must be scraped to get rid of the greasy coating, and then scalded or burned as previously directed.

After the limewash has been scraped off the walls, all food left in the mangers, the bedding, manure, etc., must be collected and placed outside and burned, passing curry-combs, pails, pitchforks, shovels, etc., through the flames at the same time. The stable flooring can be burned as



previously directed, or the floor washed with boiling water, soap, and carbolic acid, in order to render the surface fit for the penetration of whatever disinfectant is employed.

It is in the scrubbing of wood and iron work, both of fittings and doors, where the greatest supervision is required, the out-of-the-way parts and places difficult of access are forgotten, and in this way the whole value of the work may be thrown away.

Boiling water, soap, and carbolic acid must also be applied to the wall over the manger, whether it be tile, cement, or plaster.

In this way the pores of the stable are open for disinfection, which may now begin either by the slow process of washing the walls down by hand with a disinfectant, viz., a solution of lime chloride, carbolic acid, or Izal, or preferably by spraying these solutions over the entire surface as just described. All windows and doors are left open for the purifying effects of the free perfusion of air, and the disinfecting action of sunlight. For safety the spraying process may be repeated in two days' time. The stable or shed may now be limewashed, the wood and ironwork painted, and the building is fit for occupation.

Where underground drains exist, these must be flushed out with water and crude carbolic acid. In connection with this, it may be noted that the most thorough application of the disinfectant to the floor must be made. Most stable floors afford thousands of nooks and crannies where pathogenic material may lodge, and no effort should be spared to thoroughly clean them out.

*Water troughs* may be disinfected by scrubbing them inside and out with boiling water, soft soap, and carbolic acid. They are then thoroughly washed with a disinfectant, and the process repeated three times for safety.

The disinfection of *leather work* is generally unsatisfactory, as most of the disinfectants rot it. A preliminary scrubbing with soft soap and warm water should be given, and the leather allowed to dry. It should then be scrubbed with a 5 per cent. solution of Izal and this repeated. In

our experience prolonged immersion in a 5 per cent. solution of Izal or 10 per cent. solution of chloride of lime has no destructive effect on leather. The lining of collars and panels must be thoroughly dealt with as above, and dried between each application.

In cases of mange, especially sarcoptic, it is often desirable for the purpose of safety to destroy the lining and stuffing of both saddles and collars, and have then made up afresh.

*Disinfection of Blankets and Grooming Utensils.*—This should be practised by steeping them in a quantity of disinfectant for several hours. In sudden outbreaks of disease, such as mange, where no facilities exist for steeping blankets in bulk, a large bath may easily be made with a sail-cloth, waggon or rick cover, a place having been dug in the ground, and the sail cover placed in it so that it covers the bottom and sides. It should now be tested to see if it is watertight, and then the proper amount of disinfectant added.

The blankets are opened out one by one and laid in the bath, care being taken that there is always sufficient disinfectant to thoroughly cover them. They should remain in the bath not less than twelve hours.

*Disinfection of Attendants.*—In such diseases as rinderpest, foot and mouth, swine fever, etc., the virus is readily carried about from place to place by those in attendance on the sick. Precautions should be taken in this respect to provide all having to do with such diseases as foot and mouth—the contagion of which is readily conveyed on boots and clothing—with proper covering and suitable boots, which never leave the infected premises, and are destroyed at the end of the outbreak.

Both boots and clothing should receive a disinfection daily, so that a change of material is required; further, no one should be allowed to leave the affected spot without being previously disinfected, the hands and boots receiving special attention.

One of the earliest provisions to be made in an outbreak

of disease is a large bath of disinfectant for this purpose. Butchers and cattle men are the chief people to watch. They have been largely responsible in the past for carrying disease about the country, or even importing it. A disinfectant must be appointed, whose sole duty it is to deal with those brought in contact with the sick, and disinfect them before leaving the premises. Half measures in this matter are no use ; the boots and hands must be immersed in the solution and scrubbed. The next most dangerous portions of clothing are the sleeves of the coat.

The *disinfection of horse-boxes and cattle-trucks* is a matter of the utmost importance. Great complaints have been made against railway companies for neglect in these matters, more particularly horse-boxes.

Both of these structures should be disinfected on the lines laid down, the box should be washed with hot water, soft soap, and carbolic acid to remove the grease ; partitions and padding subjected to the same routine. Mangers and flooring scrubbed, any manure or bedding destroyed by fire, and the entire surface sprayed with the disinfectants previously mentioned two or three times at intervals of two days. In the meantime, every part of it should be thrown open to the wind and daylight.

Cattle-trucks should be scraped to get off all the old lime-wash, which is in flakes and cakes. Nothing should be done in the way of disinfection until this is removed. All excreta should be collected and burned, the walls and floor washed with boiling water, soap, and carbolic acid as before, and then the disinfection may begin by means of the spray or brush several times repeated. On top of this may be placed a coating of fresh limewash. (See also *Transit of Animals*.)

*Ship Disinfection.*—There is perhaps no place so absolutely filthy as a cattle boat, and its thorough disinfection can only be properly performed by a sufficiency of labour.

Let a case be supposed where a boat has landed a cargo of cattle found to be suffering from foot and mouth disease. For the purpose of thorough cleansing this ship must be

sent to sea, and when not less than forty miles from land cleaning operations should begin on the lowest occupied deck, the whole of the solid excreta, fodder, and fittings being brought up and thrown overboard. The steam pump is now turned on, and every portion of the ship's side and decks thoroughly washed down, not a place must be omitted. The other decks should be dealt with on identical lines, the most thorough and prolonged flushing being given. The bilge should be pumped out, and disinfected with carbolic acid.

In this way it is assumed that everything in contact with the animals capable of being destroyed has been thrown overboard, and the decks and sides of the ship thoroughly washed. The place is now ready for disinfection either with carbolic acid, chloride of lime or Izal, and again the spraying process previously described may be introduced, every corner, nook, and cranny being searched with the jet. The ship may then be put back to port, and the disinfection repeated in two days' time. Painting is advisable, and the vessel is then free to carry another cargo. (See also *Transit of Animals*.)\*

*Disinfection of Hides, Harness, and Hoofs.*—This may be obtained by placing them in large vessels containing sufficient disinfectant, where they are to remain several hours. This disinfection only applies to the offal of the incontacts, that belonging to the affected animal is destroyed, if possible by fire.

*Cremation.*—The destruction of diseased animals and their excreta is best done by fire. It is a costly process but absolutely satisfactory, and is time saving compared with the labour of digging deep trenches for the reception of bodies.

Field cremation is easily carried out. Nothing is required but a trench dug in the ground in the shape of a + (Fig. 171). Each trench is 7 feet long, about 15 inches wide, and 18

\* At ports in Great Britain which are specially told off for the landing of foreign animals, all facilities exist for dealing with infected cargoes and ships.

inches deep at the centre, where the two meet, becoming shallower as they rise to the surface of the ground (Fig. 172). The earth is thrown into the angles formed by the trench (Fig. 171, *aa*), and on this is placed two stout pieces of iron. In our field cremation work, where we have had several fires going at a time, two pieces of ordinary railroad rail 3 feet

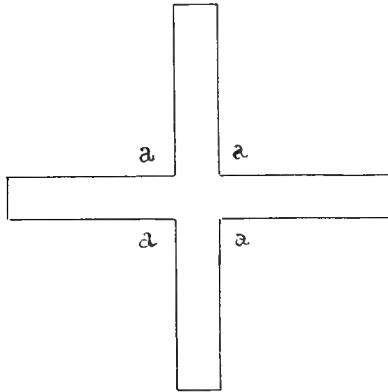

Fig. 171.—Ground-plan of Trench.

long were used, and these prevented the body falling into the trench. The use of the trench is to provide the needful draught.

Bodies can be burned whole, but it takes more fuel, and occupies about twelve hours. The quickest method is to eviscerate and remove the limbs; a layer of stout wood is now made as a base, and on this is placed the trunk,



Fig. 172.—Section in the length of the Trench.

followed by more wood, on which the limbs are placed, then another layer of wood with the viscera on top (Fig. 173). The pile is lighted with straw, and the wood, if damp may require assistance with paraffin. The animal is readily consumed in five or six hours. The ashes may from time to time be raked out of the trench to keep the air passage clear.

The blood shed by opening the body may easily be scraped up with the earth and thrown into the fire. It is only in cases of anthrax that any serious objection can be offered to evisceration before cremation, but with care no harm need arise. We have burned over a hundred anthrax bodies by the above method. The greatest care was, of course, taken to collect everything that was shed on the ground and throw it on the fire; further, the hot ashes were subsequently scattered all over the place where the body had been opened.

Incinerators should exist in all towns and cities, attached

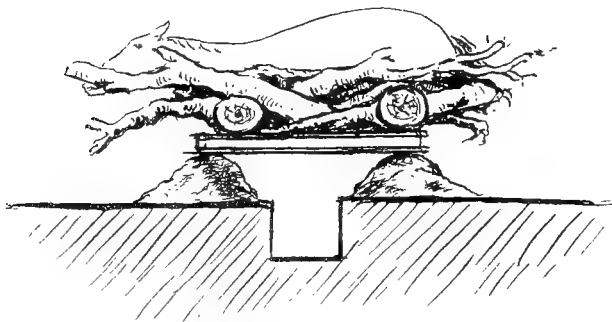

Fig. 173.—Body arranged for Field Cremation.

to slaughter-houses, knackeries, etc., for the destruction of diseased portions, and in the case of knackeries for the incineration of cases of contagious disease.

Fig. 174 shows an incinerator in use by the Royal Commission on Tuberculosis at Stansted, for the cremation of the carcasses of animals which have died, and the destruction of their litter and excreta.

The charging hole is on the top, and the carcass has first to be cut up. In order to destroy all smell, the gases of combustion are passed through a second furnace—the door of which can be seen at the side—so that before reaching the chimney they are entirely destroyed.

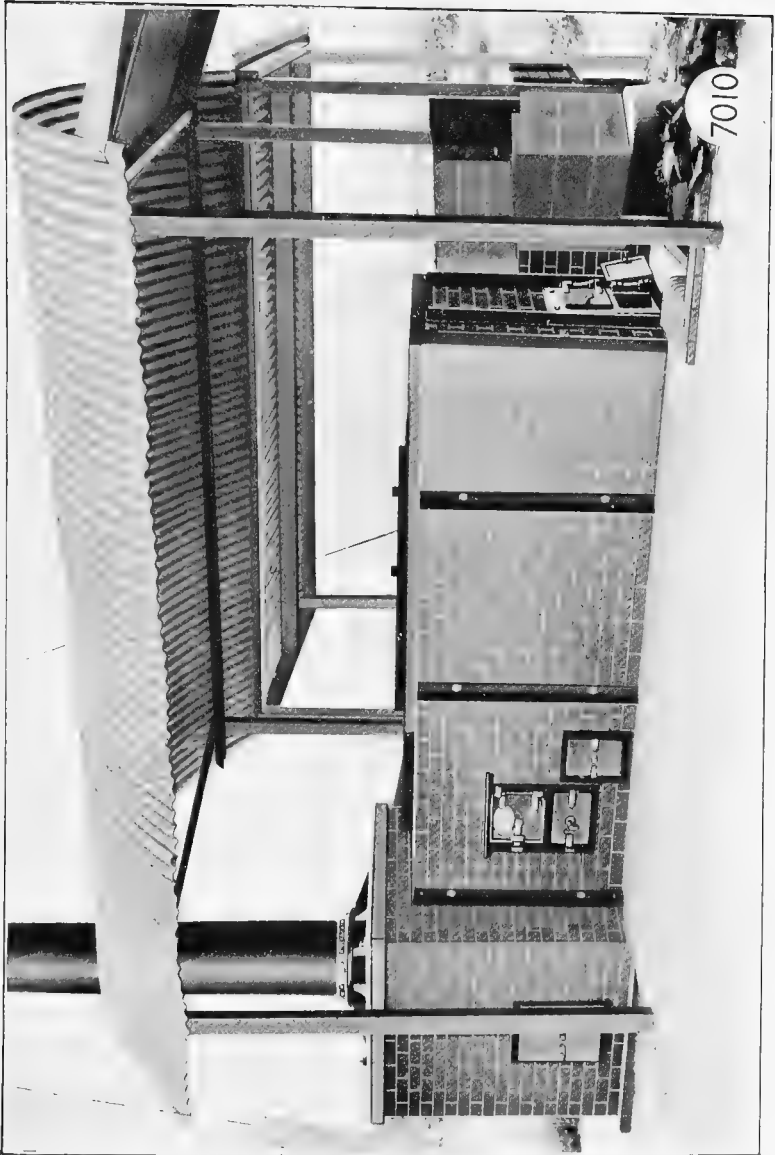

Fig. 174.—Incinerator for Animals (Manlove and Alliott

To face p. 114.





CHAPTER IX  
PARASITES

THE subject of parasitic attacks on the lower animals, especially the herbivora, is of extreme importance. Losses from this cause are very heavy, and in some years a veritable plague.

Both within and without the profession insufficient attention has been paid to this matter, either from a hygienic or therapeutic point of view. There is, for example, no disease which causes such a heavy monetary loss as the warble fly, but in spite of the fact that we know every stage of its life history, how to effectually deal with the affected animals, and the methods of preventing attack, yet little or nothing is done. Had warbles been due to a minute microbe, it is quite possible that a cry would have been raised for an antitoxin; but being due to so common a thing as a maggot, it is neglected and allowed to run its course, with practically no attempt at prevention.

The ravages of stomach and intestinal parasites have also received insufficient attention. Heavy losses result from these, yet neither prevention nor treatment have received the consideration they deserve, and the same indeed applies to most internal parasitic diseases.

It is only those directly contagious that have occupied any position of importance, yet none of these are fatal, while those of the stomach and intestines, liver and lungs, are frequently so. The life history of these latter parasites prevents them being directly infectious, and the necessity for an intermediate host gives a false sense of

security ; but it may at once be said, and the fact will be very apparent in the following pages, that sheep with fluke, cattle with stomach, and horses with intestinal strongles, are a greater risk of infection on pasture lands than if the animals were suffering from anthrax. The anthrax animal is only dangerous if its blood be shed, but every evacuation from the above parasitic patients may be a source of future trouble, and, in the same way, every cough from the calf or sheep with 'husk,' scatters the ova of the parasite broadcast.

When it is remembered that a pure water-supply and clean pastures would practically eradicate many of the internal parasitic diseases, it is obvious that the remedy lies in the hands of the owner. We deprecate grandmotherly legislation, but it is not too much to ask that owners of animals should be compelled to provide a pure source of water, clean surroundings, and suitable protection for animals, and this is the only class of legislation against disease, viz., prevention, which should be delegated to the local authorities.

Parasites are organisms which pass the whole or part of their life living on and being nourished by other organisms. They may belong to the vegetable or animal kingdom, and in these attacks a distinction is made between those that only by accident, as it were, live on animals, and those which are unable to live or complete their cycle of existence in any other way. The former are called *facultative* or occasional, the latter *obligatory* or constant parasites.

Animal parasites may be divided into two classes, those that live outside and those that live within the body. Zoologically, they are divided into three groups, the arthropods, worms, and protozoa. The latter will be considered in the chapter dealing with bacteria.

We cannot within the scope of this work do more than draw attention to the various parasites, excepting those which are pests or cause widespread disease, and these will be dealt with in greater detail.

ARTHROPODES.—The *Acarina* consists of several families,

of which the two following are the most important from a hygienic point of view, viz., the *Ixodidae* (Ticks), and *Sarcoptidae* (Mange acari).

**IXODIDÆ.**—The Tick family has recently become of special interest, as some members have been found to act as carriers of specific disease, of which the following are at present known: Rhodesian Red Water (East Coast Fever) is carried by a brown tick very widely distributed in Africa, and known as the *Rhipicephalus appendiculatus*. Texas Fever, or ordinary Infectious Hæmoglobinuria of cattle, is conveyed by the *R. annulatus*; the tick fever of Australia is carried by the *R. Australis*, while another variety transmits the 'Tristezza' disease of the Argentine. All these diseases are due to an intra-corporal micro-organism, and it is most likely that other varieties of tick than those mentioned may act as carriers, for example, East Coast Fever may also be carried by the Black-pitted Tick (Theiler).

Other tick-transmitted diseases are Bilious Fever of the horse, and Malignant Jaundice of the dog, seen in South Africa, the latter carried by the *Hæmaphysalis leachi*. 'Heart-Water' in cattle, sheep, and goats (also a South African disease), is inoculated by the *Amblyomma hebræum*, which besides acting as a carrier produces suppurating sores on the udders of cows. The Hæmoglobinuria of European cattle is produced by the *Ixodes redwivius*, while 'Louping-ill' of sheep is popularly connected with the bite of a tick.

Thus, there is quite a list of formidable diseases in which these blood-sucking parasites play a part of supreme importance. Further, though some of these diseases may be reproduced by the direct inoculation of virulent blood, or even the blood of the recovered animal—Texas Fever for example—others, like African Coast Fever, must pass through the tick as an intermediate host before infection can result, and in this particular case it must pass through a special species of tick.

But the behaviour of the tick in all cases is not quite the same. In Texas Fever, 'Tristezza,' Tick fever, and

Hæmoglobinuria, the adult female passes the organism into the egg, and the larvæ resulting from this infected egg are alone capable of producing the disease.

In Pyroplasmosis of the dog the infection is passed through the egg, larvæ, and nymph, but only the adult can communicate the disease, the larva and nymph being innocuous.

In East Coast Fever and Heart-Water another variation is observed. Infection is taken up either in the larva or nymph stage, and communicated by either the nymph or adult. Unlike the above-named diseases, the virus cannot pass through the egg.

Ticks are essentially blood-sucking parasites, they live on blood and that only. They are capable of taking in a relatively enormous supply so that, for example, a seed or larval tick which before feeding is almost too small to see, after feeding is swollen and very evident. Adult ticks may gorge themselves to such an extent as to measure an inch in length, three quarters in width, and weigh one-tenth of an ounce.

The drawings shown in Fig. 175 are to scale, and give a good idea of the normal size of the insect at different stages of development, both in a fasting and gorged condition. Long periods of fasting, weeks and months, may be experienced without the tick dying.

A full-grown tick is not at once developed from an egg, but passes through four stages of development, and these are interesting from a pathogenic point; the life stages are :

1. *The Egg.*
2. *The Larva* or seed-tick, possessing 6 legs.
3. *The Nymph*, possessing 8 legs.
4. *The Adult* or sexual tick.

It is the larvæ which first attack the animal, having previously crawled up stems of grasses or bushes, and there waited patiently for weeks or even months for a host to appear. In some species of ticks the whole of the sub-

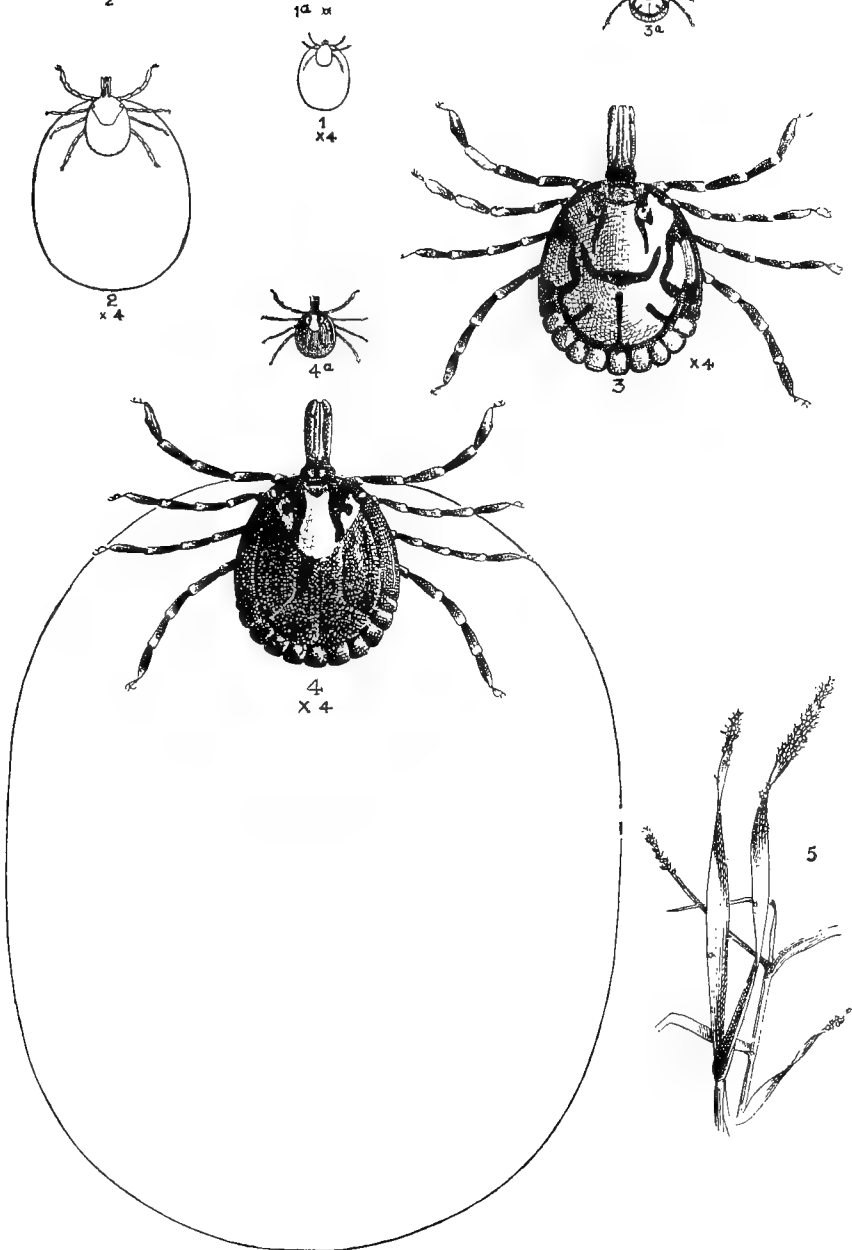

Fig. 175.—Life Stages of the Bont Tick which produces Heart Water in sheep (Lounsbury).\*  
 1a. Larva, natural size; 1. Larva, enlarged four times; the hair line shows its size when distended with blood; 2a. Nymph, natural size; 2. Nymph, enlarged four times; the hair line as above; 3a. Male adult, natural size; 3. Male adult, enlarged four times; 4a. Female adult, natural size; 4. Female adult, enlarged four times; hair line as above; 5. Larvæ of ticks on stems of grass waiting for a host.

\* Report of Government Entomologist, Cape of Good Hope, 1901.

sequent stages of development are passed on the animal, the tick holding on by its mouth parts; with other varieties between each gorging period the tick falls to the ground, undergoes a change of development, and once more gains access to the host before described.

In consequence of this habit, Theiler divides ticks into three biological groups, viz., ticks with one, two, and three hosts.

The tick responsible for Red Water passes the whole of its life on the animal body, and the females drop off to lay their eggs and die; but in East Coast Fever, Heart-Water of Sheep, and Malignant Jaundice of the Dog, each stage is passed off the animal body, further development taking place in the ground, and a more perfect parasite each time regaining its host.

The number of eggs laid by the female before death differs with the species, but from 4,000 to 15,000 are known to be laid. We may now, with a little more detail, follow the stages of development of a pathogenic tick, selecting that which at present is the most interesting one, viz., the 'brown tick' of South African East Coast Fever.

This cattle tick has three feeding stages, to explain which it is necessary to begin with the eggs. These are generally laid in the ground in a sheltered position, and take from a few weeks to a few months to hatch out, depending on the temperature. The result of their hatching is the extremely small *larval* tick, which climbs up bushes or grass, and is brushed off by passing animals (Fig. 175). Having reached the latter, they proceed to feed, which occupies a few days, and when distended with blood they drop off. The distended larval tick is at this time no larger than the head of a pin.

About a fortnight is now spent in digesting the store of food accumulated. Further, a new skin has to be formed to take the place of the old one, and certain changes in structure occur by which the tick gains new mouth parts and two more legs. This, known as the *nymph* or second stage, is distinguished from the larval

condition by the tick having four pairs of legs instead of three. Once more the tick, now much larger, finds an animal host, again gets distended with blood, drops off on to the ground once more, and for the second time goes through the process of moulting and a change of appendages. From this is finally produced the adult tick, which finds its way on to an animal by grass or bushes, as previously described, drops off when full of blood, and the female ends its life by laying several thousands of small eggs, which again go through the stages of larva, nymph, and adult.

The rate of development of these changes depends on the temperature. They are retarded by cold and accelerated by heat, but at most not more than two generations are produced in one year.\*

The blue tick of Texas Fever can only renew its infection through diseased or immune cattle, so that should it pass its life on the horse, sheep or goat, the infection in the next generation is entirely lost.

In malignant jaundice of the dog the infected larva may be carried by a jackal, the nymph carried by a cat, and finally the adult give a dog the disease though no strange dog has been in the place for years. In the same way the infected brown tick of East Coast Fever may be carried by many hosts and finally infect cattle; the Heart-Water tick if infected may pass its nymph stage on the horse, be carried some distance, and should it pass its next stage on a susceptible animal Heart-Water results. It will be seen that the great danger with these ticks results from the various dropping stages, for they retain their infection in

\* All that is here related about ticks and their life-history is taken from the published papers of Mr. C. P. Lounsbury, B.Sc., Government Entomologist, Cape Colony, who has devoted years of work to the question of ticks in connection with animal diseases, and has recently discovered the remarkable part played by the tick of East Coast Fever in transmitting this plague. See particularly *Agricultural Journal Cape of Good Hope*, vol. xxiv., No. 4, 1904. Compare also Theiler, 'Transmission of East Coast Fever by Ticks,' the *Transvaal Agricultural Journal*, vol. iii., No. 9, 1904.

spite of passing part of their existence on a non-susceptible animal, and in the case of Heart-Water a single minute nymph-tick, if infected, is sufficient to give the disease in a fatal form.

If there were no ticks there could be no East Coast Fever, a disease which threatens to clear off nearly all the cattle in South Africa. The hygienic aspect of the case—and the same remark applies to other diseases which are tick transmitted—is to get rid of the ticks. By this means such scourges as the above, Texas Fever, 'Heart-Water,' etc., would either be kept under control, or the diseases entirely disappear.

Dipping or spraying cattle regularly appears to be the only solution of the problem. The most effective dip is an arsenical one, such as has been used for years by farmers in Queensland and elsewhere. The cattle may be run through the bath at the rate of ten or twelve a minute, but a smaller bath must be employed for sheep. To get clear of ticks all herbivorous animals on the farm must be 'dipped.'

The Agricultural Department of Cape Colony recommends a Cattle-dipping Tank, seen in Fig. 176, and points out\* that if it is desired to get completely rid of ticks, the dipping must be carried out at sufficiently short intervals to prevent females from maturing. If the object is merely the reduction of the ticks, dipping once in fourteen or eighteen days is sufficient.

Dipping must be accompanied by fencing, and so prevent all tick-infected stock from entering within the area which is being cleaned. Stock which are tick free should not be taken outside the fencing excepting for sale or the butcher, and in the same way, no fresh stock should be introduced without being dipped.

The tank is 44 feet long at the top, 12 feet long at the bottom; 4 feet 6 inches wide at the top and 2 feet 6 inches wide at the bottom. The pulley block seen in the figure is to haul in obstinate animals.

\* *Agricultural Journal Cape of Good Hope*, vol. xxv., No. 2.





The Queensland Dip used with this bath consists of 8 lbs. White Arsenic,  $4\frac{1}{2}$  lbs. Caustic Soda,  $2\frac{1}{2}$  gallons Stockholm Tar, and 8 lbs. Tallow boiled in 400 gallons of water.

If spraying instead of dipping be adopted, a mechanical mixture of paraffin and water is employed. Oil-water spraying is generally carried out by a special pump, which delivers a definite proportion of paraffin and water, the two being delivered mixed into the tubing, where by means of a special nozzle they are projected with some force in a finely broken condition. The difficulty in all pumps is to maintain a constant ratio between the oil and water; 20 per cent. of oil in the mixture is recommended for ticks on cattle, if weaker than this the ticks are not killed, if stronger the skin gets blistered. Paraffin kills ticks quicker than arsenic, but it is more difficult to spray properly than to dip properly.

SARCOPTIDÆ.—Of the several sub-families of Sarcoptidæ, the Sarcoptinæ or Mange Acari, containing the genera *Sarcoptes*, *Psoroptes*, and *Symbiotes*, are of greatest hygienic importance.

*Sarcoptes* affects all herbivora; it burrows, and tunnels canals or galleries in the skin, producing a disease which in some animals—for example, the horse—is a most serious and formidable complaint. In the sheep sarcoptic mange is not a dangerous disease, and exclusively affects the face; in the pig it is the only form of mange affecting this animal, and from both the pig and horse a transient form of the disease is said to be transmissible to man.

*Psoroptes* is far less serious. This genus lives on the surface of the skin, and bites but does not burrow, though, as may be imagined from its mode of life, it spreads very rapidly, and produces the common parasitic skin disease of all herbivora.

*Symbiotes* does not produce a serious disorder in any animal. Among horses it is mainly confined to the legs of the coarser breeds, and in connection with its eradication it is important to remember that the acarus may live for a long time in litter.

A skin irritation in horses may be produced by the acari of poultry, but the disease does not spread, and may be cured spontaneously by removing the animals from the affected area.

Scabies or mange in animals, especially the horse and sheep, is a most formidable disease from the rapidity with which it spreads and the number affected. Being a highly contagious malady, we may conveniently consider the methods of stamping it out in the chapter dealing with epizootic diseases.

INSECTA.—Under this head have to be considered the various forms of *Diptera* (2-winged flies) which attack animals, and the less formidable family of *Pediculidæ*, or sucking lice.

The *Diptera* may, as affecting animals, conveniently be classified as follows :

*Culicidæ* or Gnats.

*Tabanidæ* or Gad-flies.

*Æstridæ* or Bot-flies.

*Muscidæ* or House-flies, Stable-flies, and Sheep-maggot-flies.

*Hippoboscidæ*, the Louse-flies, and Forest-fly.

The *Culicidæ* represent a very important group of insect pests to man, though their attack on animals is not common; but a family to be mentioned presently, the *Simuliidæ*, closely allied to the *Culicidæ*, is a perfect plague to horses, and may even cause death. Gnats and mosquitoes are proved to be important as carriers of infection. It is quite certain that the malarial fevers of man are conveyed by a species of *Anopheles* (one of the mosquito group), and another carries Yellow Fever. Filaria disease of man is also transmitted in this way, likewise the *Proteosoma* of birds, and there is good reason to believe that Horse-sickness and Malarial Catarrhal Fever of Sheep of South Africa are inoculated by another fly.

In all the *Culicidæ* it is the female which is the blood-sucker, the males are harmless; the sucking is accom-

plished by means of a proboscis, the skin being pierced by lancets.

The mosquito's life-history is briefly as follows: the eggs are laid in a bunch in stagnant pools; from the egg hatches a larva, which, full fed, passes into the pupal stage. Respiration is accomplished by means of a projection in the case of the larva and two horns in the case of the pupa, which are thrust above the surface of the water. When pupation is over the pupa skin ruptures and the fly emerges.

A knowledge of the life-history enables preventive measures to be adopted for the eradication of mosquitoes in malarial districts. The mosquito gets the malarial organism from man, but without the mosquito it cannot be transmitted; therefore, if mosquitoes are destroyed malarial fever ceases. To attain this end it is obvious the breeding places of the insect must be attacked; pools should be filled in or drained; while any larvæ in a pool will be suffocated if a film of paraffin oil be allowed to form over the surface.

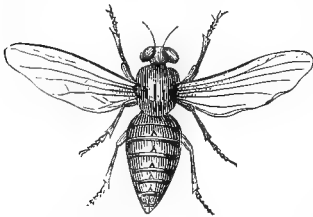

Fig. 177.—*Tabanus bovis*, the Ox Gad-fly; natural size.

*Tabanidæ*,\* *Gad-flies* or *Breeze-flies*, so named from the buzzing sound they make, attack both horses and cattle. The females are blood-suckers, the mouth parts being armed with six lancets for this purpose. This is a very large family, and comprises many species. The best known is *Tabanus bovis*, or the Ox 'Gad-fly' (Fig. 177), the female of which worries cattle from the end of May to the autumn. It is a big fly as much as an inch in length, with a longitudinal row of whitish triangles along

\* The description given here of the various flies is taken from a valuable paper, 'Insect Pests of Domesticated Animals,' by Dr. Stewart MacDougall, Consulting Entomologist, Highland and Agricultural Society of Scotland. See *Transactions*, vol. xi., 5th series, 1899. See also 'Flies Injurious to Stock,' Elleanor Ormerod, LL.D.

the middle of the dorsal surface of the reddish brown abdomen. The thorax is hairy and brownish black in colour, with dark stripes. The male is not aggressive.

*Hematopota pluvialis*, also known as the 'Cleg,' or Horse Breeze-fly (Fig. 178), is very troublesome during late summer; the female pierces the skin and lives on blood. The fly is narrow and rather less than half an inch long, with longitudinal pale stripes on the thorax, and a pale band and greyish spots on the upper surface of the abdomen. The wings have light coloured markings, and the eyes are a beautiful green.

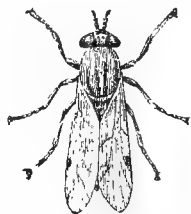

Fig. 178.—*Hematopota pluvialis*, the Cleg or Horse Breeze-fly; enlarged two diameters.

*Chrysops cæcutiens*, or the Blinding Breeze-fly (Fig. 179), principally directs its attacks around the eyes, and has been found to produce conjunctivitis in horses. In length it is about  $\frac{1}{3}$  inch. The wings are held somewhat apart, the eyes are golden green with purple lines and spots, the female is brownish-black in colour with a yellow band across the abdomen.

All these flies lay their eggs in the earth, and the maggots or larvæ live on vegetable matter. The pupa is also in the soil.

The family *Simuliidæ*, previously alluded to, are sometimes called in America Buffalo gnats, or 'black flies.' They usually keep to wet places and fly in swarms towards sunset. The *S. meridionale* in America is reported to kill animals, and a species found on the Danube, *S. columbaschense*, hardly larger than a flea, is most aggressive



Fig. 179.—*Chrysops cæcutiens*; twice natural size

and even death producing.

The *Estridæ* or *Bot-flies* are a very important family owing to the amount of damage they inflict on animals. They are divided into three sections according to the seat

the larvæ are found to occupy, the *Cuticola*, *Gastricola* and *Caricola*, of which the Ox Warble, Horse Bot and Sheep Nostril flies are examples. The object with which all bot flies attack animals is to deposit their eggs or larvæ only.

The adults have their mouth parts practically abortive.

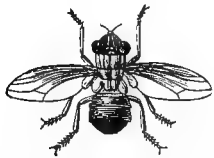

Fig. 180.—*Hypoderma bovis*; natural size.

*Hypoderma bovis*, Ox warble or Bot Fly (Fig. 180), is one of the most severe insect pests to cattle living in the open. The fly by its presence is said to alarm cattle, and causes them to gallop wildly about, so much so that cows may even

bruise their udders in their panic. The flight of the fly is rapid, it hovers over the cattle, then suddenly drops and deposits an egg on the back, rises again and repeats the manœuvre. The egg is now fixed to the hair, and hatches in the open into a maggot, which then proceeds to make a hole for itself in the skin. It lies beneath the skin during the autumn and winter, during which time it moults, grows, and changes its appearance and colour.

In the spring a tumour forms, which has an opening in the centre, leading down to the 'warble cell.' Through this opening the maggot when full grown (Fig. 181) squeezes its way, and falls to the ground, where it becomes a pupa and finally the fly emerges.

It has now been shown, in the case of *H. lineata*, the common American species of Warble fly, that the embryo is licked off the skin, and being taken into the mouth it fixes to the throat and then bores its way to below the skin of the back where the Warble is formed. It is possible that this will also be proved for *H. bovis*.



Fig. 181.—  
Larva of *Hypoderma bovis*.

The fly is about  $\frac{1}{2}$  inch long, with yellow hairs on the face, yellow and black hairs on the thorax, while those on the abdomen are yellowish white in front, black in the middle, and yellowish-red posteriorly.

The maggots do considerable damage to animals from the irritation set up in them, while they ruin the hide

for the purpose of leather. Miss Ormerod calculated the loss in Great Britain and Ireland was not less than two millions a year. It has been suggested it should be made a scheduled disease, and all owners of warbled cattle compelled to dress them during the spring, at a time when the disease is practically under control, for it is obvious if the larvæ are then killed no fly develops.

For this purpose the following should be used every few days to the holes in the back, viz., a mixture of Sulphur, Creosote, and Train Oil. This placed on the openings into the tracheæ suffocates the larvæ;\* the same results from the application of mercurial ointment. It is better, however, to squeeze out the larvæ in the spring and kill them. As a preventive measure cattle before being turned out to grass should be dressed along the back and shoulder blades with Stockholm tar,† or butter and tar mixed with sulphur. Sheds give protection against fly attacks, and it is said the flies will not cross water. This is a common characteristic with some of the most formidable fly pests, for example *Tse-tse*.

*Gastrophilus equi* or Horse Bot Fly is about half to two-thirds of

an inch long, with reddish hairs on a dark banded thorax, and yellowish brown hairs on the abdomen. The eggs are deposited on the hair (Fig. 182), principally in the region of the fore-limbs, and are about  $\frac{1}{12}$  inch long. When the egg is hatched, the larvæ pushing off the lid, and their wriggling causing irritation, the horse rubs by the lips or licks the place, and so the larvæ are conveyed to the mouth.

In the stomach the larvæ attain their full size, about  $\frac{3}{4}$  inch. They are provided with two hooks around the mouth, by which they anchor themselves to the wall of

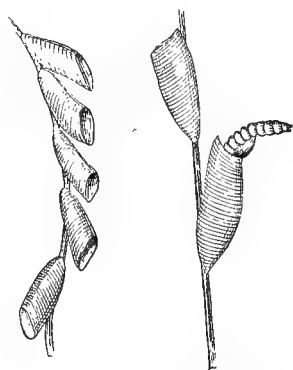

Fig. 182.—Eggs of *Gastrophilus equi* attached to hairs of horse and showing larva just hatched (magnified).

\* Recommended by Mr. Thomson, M.R.C.V.S., Aspatria.

† *Ibid.*

the stomach, for choice to the cuticular coat, though sometimes they are found on the villous area. Here they remain 9 or 10 months, then let go their hold, and reach the ground with the fæces; the pupal stage is passed in the ground, and the fly emerges in 5 or 6 weeks.

It is difficult to fix the amount of harm done by horse bots; the stomach is frequently found to contain a considerable number of the larvæ without apparently causing inconvenience, but there is abundant evidence that they can produce harm, and every attempt should be made by destroying the eggs on the skin at frequent intervals to prevent the hatching out process. For this purpose horses at grass might be dealt with once a week, by being caught up and a singeing lamp passed over the egg area. The dressing used for oxen may also be employed to repel the fly.

*Gastrophilus hæmorrhoidalis* is a second species of bot-fly which attacks the horse. The female lays her eggs about the lips, and the larvæ are easily conveyed into the mouth, where they may fix themselves in the pharynx, or preferably the rectum. Their removal from either of these places is not difficult if their presence is suspected.

*Æstrus ovis*, the *Sheep Nostril Fly*, deposits eggs ready to hatch, or larvæ, on the nostrils of sheep; the larvæ crawl up the nasal chambers and accommodate themselves in the frontal sinuses and horn cores. This occurs about July, and the maggots remain in the sinuses until the spring, when they migrate into the nasal chamber and are sneezed out; in six or eight weeks after pupation they develop into a fly.

This fly greatly alarms sheep which fight against it, carry their noses low, and take refuge wherever they can crowd together with their heads near the ground. The fly attacks with great rapidity, circling around the sheep, and watching for the needful opportunity for depositing the maggot.

Sneezing, discharge from the nose, and staggering gait are very suggestive symptoms of the presence of the larvæ of this fly. Remedial treatment is difficult. For prevention the smearing of the nose with tar is effectual, but obviously difficult of application with large flocks.



The *Muscidæ* are a very large family, several of which are not only blood-suckers but transmitters of disease. *Musca domestica*, the common house-fly, lays its eggs in horse manure and here the maggots feed. Horses may be largely prevented from attacks by the use of netting or a body cover, also by keeping the stable dark, and hanging up bushes or strings for the flies to settle on; further the insects may be driven out by smoke. All these measures are only partly successful by themselves, and more valuable when combined. Well bred horses are severely punished by the irritation caused by these flies.

*Stomoxys calcitrans* (Fig. 183) resembles the house-fly, and is often mistaken for it, but the proboscis projecting in front of the head distinguishes it. By means of this proboscis it is capable of blood-sucking and inflicting a severe sting; it is a most irritating fly in the stable. Within this fly is passed the larval stage of a parasite of the ox, *Filaria labiato-papillosa*, which is inoculated into the animal by the bite of this insect.



Fig. 183.—*Stomoxys calcitrans*; twice natural size.

Closely allied to the above are the *Hæmatobia*, blood-sucking flies which never enter buildings but attack animals at pasture. An American species, known as the 'horn-fly,' selects the base of the horns to rest on, and attacks the back, flank, and upper parts of the limbs.

This fly not only irritates horses by its bite, but is a carrier of disease; it is believed to convey the trypanosome of 'mal de caderas' of the Argentine, and Haslam found in the body of a Central African variety the trypanosome of Tse-tse disease.

The *Glossina* contains eight species, of which *G. morsitans* genus is one of the most important.\* This fly is found in

\* For a full account of the Tse-tse flies, see the monograph on this subject by Mr. Austen, British Museum of Natural History Publications.

many parts of Africa, and is capable of causing immense loss by inoculating animals with the *Trypanosoma Brucei*, obtained from wild animals which are immune to the disease. Whole districts of domesticated animals may in this way be cleared off, for the disease attacks the horse, mule, ass, ox, and is usually fatal, though a few oxen recover.

The fly, which during its flight emits a high-pitched buzz, is greyish-brown, and about half an inch in length with a prominent proboscis. The position of the wings at rest, viz., close together, and lying flat over each other like the blades of scissors, distinguishes the Tse-tse from all other flies.

The fly attacks suddenly and in the most determined way; it presses in the proboscis causing slight pain; in a few seconds the sucking is over, and the previously collapsed abdomen is now distended and of a cherry colour.

Another species, *Glossina palpalis*, has recently been discovered as the carrier of the trypanosome which produces the sleeping sickness of Uganda.

With Tse-tse flies both sexes are blood-suckers; further, unlike many of the family they belong to, they are repelled and not attracted by ordure.

Of *Blue-bottles* or *meat-flies* there are two species; both lay their eggs on decaying animal matter, and do not attack animals.

Of *Green-bottles* there are two species, viz., *Lucilia Cæsar* and *Lucilia sericata*. Both are bright green in colour, though the latter has a bluish sheen absent in the former. These flies lay eggs in wounds and putrefying matter, *L. sericata* being responsible for the disease in sheep known as 'maggot.'

*Maggot in Sheep*.—This occurs particularly with young and weakly sheep; those suffering from diarrhœa (by which soiling of the wool occurs) are especially liable to attack. *L. sericata* does not attack sheep as an absolutely necessary part of its life cycle, but because the filthy and offensive state of the fleece proves attractive, more particularly if any neglected sore exists.

The fly attack is generally in the region of the tail. A small wound may in a short time become converted into a nest of maggots, which remain and burrow until full fed they fall to the ground.

The fly does not limit its attacks to the region of the tail; the back, loins, and shoulders may also suffer. The animals are continually rubbing, biting, or scratching themselves, with constant wagging of the tail, while a dirty matted state of the wool results from the oozing of offensive fluid from the affected parts. As a result of the irritation the sheep fall away in condition, and the general health becomes impaired.

'Maggot' in sheep is generally an indication of neglect on the part of the shepherd, who, by means of his shears should remove all soiled wool from the tail region, and dress any sores with a simple antiseptic, at the period when this fly is prevalent.

The fly will not attack wool dressed with infusion of tobacco, solution of aloes, or asafœtida, nor will it attack wounds dressed with carbolic acid, paraffin, turpentine, etc.

The disease is very largely under control; frequent inspection and keeping the sheep clean, so as to render the wool unattractive, are the chief preventive remedies, while 'docking' as a sanitary measure is most beneficial.

The *Spider-flies* or *Louse-flies* are a peculiar group, of which the sub-family *Hippoboscidae* are parasitic on animals. A peculiarity in their development is that the larvæ are nourished within the body of the female till full grown, when they are placed to the outside in a pupa case, and from this in time the perfect insect emerges.

*Melophagus ovinus*, the *Sheep louse-fly* or 'Ked' (Fig. 184). These are wingless insects which live in the wool of sheep.

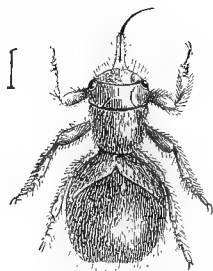

Fig. 184. — *Melophagus ovinus*, the Sheep Louse-fly, Ked or Kade, magnified. The line on the left indicates the natural length (Neumann-Fleming).

In cold weather they lie near the skin. Their presence causes considerable irritation, not only from their movements but from the punctures they inflict on the body.

The insect is about one-quarter of an inch in length and of a brownish colour. As it lives on the surface of the skin, it is not difficult to destroy by arsenical or other 'dips.'

*Hippobosca equina*, the *Forest-fly* (Fig. 185), is a winged member of the same family, and is a pest in the New Forest. The fly is about one-quarter of an inch long, of a glossy brown colour. It has a yellow head, and three pairs of strong legs, the feet of which are arranged for clinging. These flies are blood-suckers, and their movements on the horse are curious; they run backwards, forwards, or in a sideling crab-like fashion, and cause in this way the most intense irritation to animals unused to their attacks. They are both difficult to catch and to hold, and require considerable pressure to destroy.



Fig. 185. — *Hippobosca equina*; twice natural size.

Deer are also affected by a forest-fly peculiar to themselves.

*Hippobosca rufipes* has been shown by Theiler\* to be the means by which the trypanosome of South African 'gall sickness' is transmitted from animal to animal.

The *Lice* affecting animals may broadly be divided into two groups :

Biting lice of the genus *Trichodectes*.

Sucking lice of the genus *Hæmatopinus*.

Each of these genera has representatives on the horse, ox, sheep, goat, and dog, save that *Hæmatopinus* is said by Neumann not to attack sheep.

The horse is affected by one kind of *Hæmatopinus* and two of *Trichodectes*. The ox harbours two species of *Hæma-*

\* *Journal of Comparative Pathology*, vol. xvi., part iii., 1903.

topinus and one Trichodectes. The sheep has one Trichodectes. The pig has one Hæmatopinus, which is the largest known louse. The dog has a Trichodectes which is interesting as being the intermediate host of a tapeworm, viz., the *T. cucumerina*.

Lice in horses are an indication of neglect, and are certainly never found where good stable management is practised. The disease caused by them is easily cured by clipping and thoroughly dressing with any of the known remedies, of which stavesacre is perhaps the most common. It is a practical point to bear in mind that the insect is killed easier than the egg, so that the treatment should be repeated after a few days, in case any eggs have hatched out.

*Pulicidæ* or *Fleas* are only of interest as possible carriers of disease. The *Trypanosoma Lewisi* of rats can be carried by them, and the flea can also act as the intermediate host of certain other parasites.

WORMS or HELMINTHS are a frequent source of disease in the lower animals, in some cases causing widespread havoc, as in 'fluke disease' and verminous bronchitis, in others causing serious local loss, especially where the stomach or intestines are attacked. There is hardly an internal organ of the body which is not liable to be affected by parasites, but it is only in those cases where the disease is widespread that any serious attention is paid to the matter.

Our knowledge of the life-history of parasites is very incomplete. Some, like the liver fluke and many of the tapeworms, are well understood, but the origin and history of the majority are unknown.

Following the course previously adopted, we will only examine in detail those parasites which produce widespread or serious disease, the existence of the others being simply noted.

The *Cestodes* as a rule pass their cycle of existence through two hosts. The second host may vary from a warm blooded animal to a flea. It is only a knowledge of

the intermediate host which renders the prevention of this and other parasitic diseases possible.

The intermediate type of life between one tapeworm and its next generation is a *cysticercus*. Thus *Tænia solium* of man has its larval form in the *Cysticercus cellulosa* of the pig, the pig being infected by the ingestion of the human tapeworm excreted with the fæces. The *Cysticercus bovis* is the larval form of *T. mediocanellata* of man. *T. caninus* of the dog has its larval form in the *Caninus cerebralis* of the sheep. *T. serrata* of the dog is the *Cysticercus pisiformis* found in the peritoneal cavity of hares and rabbits. *T. marginata* of dogs forms the *C. tenuicollis* found in cattle. *T. serialis*, also of the dog, has its cystic form in the horse, hare, and rabbit. *T. echinococcus* of the dog has its larval form in the *Echinococcus veterinorum*, particularly met with in the liver and lungs of ruminants.

There are tapeworms of which the intermediate host is unknown, *T. expansa* of sheep and cattle, for example, a parasite which is capable of causing considerable destruction among lambs.

The prevention of tapeworm is based on a knowledge of its life-history. The cystic disease in the pig and ox is caused by their consuming human excreta, or food soiled with it, from men affected with these two varieties of tapeworm, and in no other way can they get it. Obviously the better observance of sanitary precautions in the human population is the point to aim at, while the thorough cooking of suspected beef and pork is the solution of the problem so far as man is concerned. The recognition of this disease in the ox and pig, the so-called 'measles,' will be dealt with under the Inspection of Meat.

The dog harbours the largest number of varieties of tapeworm, and is the means of infecting sheep with *Caninus cerebralis*, and cattle with *Cysticercus tenuicollis* and *Echinococcus veterinorum*.

As a means of preventing the infection of sheep with the brain hydatid or 'gid,' all dogs employed with sheep should be treated every spring with any of the ordinary tapeworm

expellers, during which time they should be carefully tied up, and their fæces destroyed by boiling water, or preferably by burning.

Very heavy losses from 'gid' may occur in a flock, but inasmuch as there can be no 'gid' without the pastures being affected from the fæces of a dog suffering from tape-worm, it is clear that the disease is well within the bounds of prevention.

The destruction of the brains of all sheep affected with the disease should be carried out with the greatest care, for if dogs have access to them they are certain to become affected.

The most important parasite belonging to the order of *Trematodes* is the Liver Fluke, *Distoma hepaticum*, of sheep. This parasite may also be met with in cattle and horses, but in sheep it causes widespread disease commonly known as 'Rot.'

*Fluke Disease.*—It will be convenient in the first place to deal with the parasite. The mature fluke lying in the bile-ducts lays its eggs, which subsequently reach the intestinal canal, and so find their way on to the land. As each fluke is capable of laying several hundred thousand eggs, and there are often scores and hundreds in one liver, it is easy to understand how thoroughly the pastures may be strewn with them. Fortunately, only a fraction ever pass beyond the egg stage, as it is necessary for the further cycle of their existence that they should pass into the body of a fresh water-snail, *Limnœa truncatula*. Within this they undergo a complex development, into what is finally known as *cercariæ*, and the water-snail with the contained *cercariæ*, or the latter already liberated in puddles or damp places, are taken in with the food or water, and the mature fluke in course of time develops.

Fluke disease can only be produced in wet pastures. It follows as the result of a long wet season, or keeping sheep on undrained meadows or marshes. It does not occur on salt marshes, for the presence of salt kills the intermediate host.

The disease does not show itself for weeks or months after infection, but when the fluke has reached maturity the effect on sheep is very evident; there is great muscular wasting, œdema of various parts of the body, while the anæmic condition is shown by a characteristic paleness of the caruncle of the eye.

The ravages from this parasite may at times be extraordinary. In 1830 it carried off in England two millions of sheep, and has repeatedly since then caused most serious losses.

The preventive measures are simple in theory, but are frequently attended by practical difficulties. The eggs cannot develop on dry pastures, so that removal to a dry site is naturally indicated. This may save some of the sheep, but leaves the old pasture still infected. This should be dried by draining, both subsoil and surface; the natural outfalls of the land must be kept in order, obstructions in ditches, brooks, etc., removed, and every facility given for the water to run off the land. Subsoil drainage is expensive, but if sheep are to be kept on the land it is imperative. In the meantime pools may be filled in, and wet portions of the land incapable of drainage, and probably infected, should be hurdled off to prevent the sheep subsequently having access.

If the pastures cannot be evacuated the sheep should be 'penned' on the driest portion and trough fed; and here a most important point in prevention occurs. If sheep are fed on good nutritious food they may practically escape infection, though neighbouring flocks may be suffering severely. A liberal supply of cake and corn is required not only as a preventive, but when flocks become affected it assists as a curative.

In addition there must be a liberal supply of common salt with the food; the action of salt on the cercariæ and the immunity enjoyed by sheep on salt marshes, suggests a top dressing of salt to the land, but experience shows that the chances of bringing either lime or salt in contact with the cercariæ are rather remote, and that this



dressing is perhaps best confined to those patches which are the most suspicious, to which it should be repeated once or twice. Land on which fluke disease has appeared is not safe to use again for two years, even after drainage of the soil has taken place.\* It is important, among other preventive measures, to bear in mind that the rabbit harbours a fluke the eggs of which infest sheep.

The *Nematodes* contain some very destructive parasites found in the respiratory, circulatory, and digestive apparatus. These nematodes are furnished by the family of *Strongyles*, which are capable in the respiratory or digestive system of producing considerable havoc among cattle, sheep, and horses.

*Bronchial and Pulmonary Parasites.*—These are well known epizootic diseases among sheep and calves, producing what is commonly known as ‘*Husk*’ or ‘*Hoose*.’ In the case of the above animals great loss of life may occur, but both the pig and horse may also have strongles in the air-passages which are neither widespread nor destructive.

Authorities do not appear to agree as to the number of different species of strongle found in the bronchial tubes and lungs of cattle and sheep, it is probable that there is one in the ox, and three or four affecting sheep.†

*Strongylus micrurus.*—The ordinary husk-producing worm of cattle.

*Strongylus filaria.*—The husk worm of sheep and lambs.

*Strongylus rufescens*—The worm which produces nodules in different parts of the sheep’s lung.

*Pseudalius ovis.*—Closely allied to *S. rufescens* and by many considered one stage of its existence.

*S. filaria* or the white thread worm, is found only in the bronchial tubes, whereas *rufescens*, the red thread worm,

\* The views here expressed are those of the late Mr. Finlay Dun, F.R.C.V.S.; see his valuable paper, ‘Report on Liver Rot,’ *Journal of the Royal Agricultural Society*, vol. xvii., 1881.

† See papers on the subject by the late Dr. Cobbold, F.R.S., and Sir George Brown, C.B., *Journal of the Royal Agricultural Society*, vol. xxii., 1886, and vol. viii., 1897.

and *Pseudalius*, the hair lung worm, are found in the substance of the lung. Husk is produced either by *S. micrurus* or *S. filaria*, and it is the disease caused by these that is here being dealt with from a hygienic standpoint, though it must also be observed that *S. rufescens* is capable when in large numbers of causing very heavy loss.

In parasitic bronchitis, both worms, eggs, and embryos are expelled in enormous numbers from both the mouth and nostrils, by the continual cough caused by their irritation. A fully grown female worm is capable of discharging several millions of embryos, and though this vast number finds its way to the soil, it is a fortunate circumstance that an intermediate host is required before they can again infect cattle and sheep. There is very good reason for believing that the larval stage is passed in the earthworm, and after undergoing certain changes is ejected from its body, and finds its way on to the surface of the soil with the worm castings. If this proves to be the invariable life-history, the infection of flocks and herds can be readily understood.

The conditions which favour infection are overcrowding of animals on the land, a debilitated state of the system through insufficient food, low-lying and swampy pastures, infected and stagnant water-supply. In connection with this, it may be observed the opinion is pretty generally held that infected food is a more frequent source of disease than infected water-supply.

The preventive measures are much the same as have already been discussed under Fluke disease. The animals must be liberally fed and receive salt; the soil drained, stagnant water railed or hurdled off, marshy or low-lying land avoided, and a top dressing of lime and salt tried. The driest portion of the farm should be selected, but it hardly seems wise to turn the affected animals on to uncontaminated pastures, considering the amount of parasitic material they are constantly ejecting. It would be far better to trough feed them and hurdle them off, changing ground frequently, and top dressing all the places occupied by

the sick with lime and salt, so as to prevent further infection.

*Parasitic gastro-enteritis of sheep* is due to two nematodes, known as *Strongylus cervicornis* and *contortus*, both found in the fourth stomach and causing heavy mortality.

The disease principally attacks lambs, but adult sheep do not escape. The question has been dealt with by McFadyean\* who first described *S. cervicornis*.

The principal symptoms are diarrhoea and muscular wasting; the disease may last a few hours, or the animal live for several days or weeks. The eggs of the parasite pass away with the fæces and undergo development in the water and soil, but the intermediate host is unknown. The parasites, judging from experiments *in vitro*, are very difficult to destroy.

Conditions which favour infection are overcrowding, stagnant ponds, and flooded lands, while the preventive measures are liberal feeding, salt in the food, a supply of good well or running water, and keeping sheep off infected pastures for two or three years.

*Parasitic inflammation of the Fourth Stomach of Ruminants*, also described by McFadyean,† is produced by two different species of strongyle, the *S. gracilis* and *S. convolutus*. In both cases the eggs pass from the stomach into the intestines and are there hatched; through the medium of the fæces they reach the soil, but their further development is unknown.

The disease lasts a long time, three to six months, and the gradual wasting is so marked that the cases have frequently been considered tubercular. The only preventive measure which can be suggested is the destruction of all fæces, for as these contain the embryos it is quite easy for them to find their way into water, or to be carried on to the land with manure.

*Parasitic Enteritis in Horses* is produced by the ravages of *S. tetracanthus*; outbreaks have been frequent after wet

\* *Journal of the Royal Agricultural Society*, vol. viii., 1897

† *Ibid.*, vol. lxiv., 1903.

seasons, more especially affecting foals. Diarrhœa, wasting, colic, and enteritis are prominent symptoms; the mortality is very high.

McFadyean\* has drawn the urgent attention of the profession to the little we know of the therapeutic measures of dealing with parasitic gastro-enteritis in the herbivora, the losses from which represent an immense sum of money annually.

The precautionary measure for preventing the spread of disease is the destruction of all fæces. If these find their way to the land the disease will be perpetuated. Nor should the drinking water be lost sight of; earlier in these pages we have expressed the view that this is one of the principal methods of parasitic infection, any filthy pond being considered a good enough water-supply for animals. One of the most important measures of preventing parasitic outbreaks is a pure water-supply. This, combined with the destruction of all infected fæces so as to prevent contaminating the pastures and water, would certainly bring these and other parasitic diseases under effective control.

*Strongylus armatus* is an exceedingly common nematode of equines with a curious history. Entering the body as embryos, probably with the water, they pass in the first instance from the bowel into the circulatory system, producing parasitic aneurism of the large mesenteric artery. From the artery they pass again to the intestine, where they lie in cysts beneath the mucous membrane.

It is remarkable, in spite of the grave changes in the wall of the mesenteric artery, what little inconvenience these parasites cause. This is not always the case, aneurismal colic has been described, and some authorities consider it a frequent cause of trouble, though we cannot endorse this view.

The *Filaria* are represented by the *F. equi* found in the peritoneal cavity of equines, while *F. labiato-papillosa* occurs in that of ruminants. Theiler frequently found it in the peritoneum of Texas and Madagascar cattle. *F. lachry-*

\* *Journal of Comparative Pathology*, vol. xiii., part i., 1900.

*malis* is found in the conjunctival sac of the ox, and *F. palpebralis* in that of the horse, while *F. inermis* occurs in the anterior chamber of the eye of equines. *F. immitis* is found in the right ventricle of the dog, while its embryos may be found in thousands in the blood-stream. *F. recondita* is found in its larval stage in the blood of the dog. *F. Evansi* in the arteries and lungs of the camel. *F. hæmorrhagica* in the subcutaneous tissues of the horse and ass, where it produces local hæmorrhages, while *F. irritans* produces 'summer sore' in horses, which has been likened to the Indian disease 'Bursattee.'

Of the Spiroptera, *megastoma*, which produces submucous tumours and abscesses in the stomach of the horse, is best known. *S. microstoma* lives on the surface of the mucous membrane of the stomach of the same animal, while *S. reticulata* is met with in the flexor tendons and suspensory ligament of the fetlock, where it produces parasitic fibromata.

Of the life-history of these parasites we possess but little information. The opinion at the present time is that blood-sucking dipterous insects may be responsible for carrying infection, as in the case of *F. labiato-papillosa* (see p. 431).

No attempt has been made to give anything like a complete list of the internal parasites of the herbivora; attention has only been drawn to those of importance from the point of view of prevention, while others are mentioned as interesting, and showing the widespread character of parasitic invasion. A consideration of *Trichinæ* is reserved for the section dealing with Meat Inspection.

*Vegetable Parasites* are represented by the class of disease known as *Ringworm*, which affects principally young animals, more particularly cattle and horses; the fungus which causes this is a pure saprophyte. Brown\* has shown that ringworm fungus will grow on the bark of a tree even after a long frost. In the reference given below

\* *Journal of the Royal Agricultural Society*, Prof. G. Brown, C.B., vol. vi., part ii., 1895.

he lays particular stress on the extraordinary vitality of the mould, and mentions that goats have been infected with crusts from cattle eighteen months after their removal. He regards the life of the fungus in pastures, yards, and cattle-sheds as being under favourable conditions indefinite.

The same authority has found the spores of the fungus in the abdomen of body lice taken from affected animals, and this discloses a source of infection which might easily be overlooked.

The fungus which produces ringworm in both horses and cattle is the *Tricophyton tonsurans*. It attacks the hair, even its interior, and in calves is at times very persistent, though readily amenable to treatment in horses. The disease generally attacks young animals, adults are rarely affected.

A characteristic feature of the disease in calves is its spontaneous cure in the course of two or three months, though this depends upon the state of health of the animal.

The preventive measures and those of eradication are based on what is known of the life-history of the fungus. Its remarkable vitality shows how thorough must be the methods of disinfection. Its saprophytic life shows how difficult it is to eradicate from a farm.

Dampness favours its growth, so that rotten wood, decaying vegetable matter, damp fields, sheds, etc., are all media on which the organism can grow; even frost has no effect on it.

Limewash should be applied to every tree, post, hurdle, rail, stable, and farm fittings to which the calves have had access. All manure and litter should be burned, or covered over with earth until ploughed in. Brown recommends a preliminary disinfection with a solution of copper sulphate or iron sulphate, which destroys the mould, and then limewash to be applied. He especially directs attention to every tumble-down building or obscure corner which has the aspect of mouldiness.

With horses, which are far less susceptible to ringworm than cattle, the preventive measures need not in ordinary cases be carried beyond the animal and its blanket; frequently nothing is done beyond destroying the fungus on the body. But there are multiple cases of ringworm where an extensive crop of the disease exists on the body, and here the suppressive measures must be very complete and thorough, blanket, harness, or saddle, bedding and stable, must all be thoroughly disinfected and the case isolated.

## CHAPTER X

### MICROBES—INFECTION—IMMUNITY \*

It would be beyond the scope of this work, and trenching on the field of pure pathology, to give even a summary of what is known regarding micro-organisms and the part they play in disease processes. All that is here attempted, is to place before the practical hygienist a brief account of a question which directly bears upon some of the most important problems with which he has to deal.

In his search for the causes producing disease, and his endeavours to combat these in the light of such exact knowledge as we possess, the question of bacteria, infection, and immunity, must ever be before him. He cannot move without encountering them, nor can he succeed in stamping out epizootic diseases without some knowledge of the life history of bacteria and how their products may be turned to useful advantage.

The principle adopted in this chapter is to give a grouping of bacteria, mentioning those responsible for disease, and discussing how they obtain entrance to the body where this is known; also the conditions favourable for their growth, how they succeed in infecting the animal, and finally giving an outline of what is known as immunity, and how it is probably produced.

\* This chapter is from the pen of Dr. Theiler, Veterinary Bacteriologist to the Government of the Transvaal, to whom I am greatly indebted. Dr. Theiler's researches in the field of pathology and his intimate acquaintance with the veterinary aspect of these questions are of especial value, and add an authority and interest to this chapter which only a veterinary specialist can command.



PROTOZOA.—Protozoa are unicellular organisms of the animal kingdom. During the last few years they have attracted a great deal of attention, as many have been found in connection with well-known diseases.

The following grouping of the protozoa is adopted :

	{	<i>Rhizopoda.</i>
<i>Plasmodroma</i>		<i>Mastigophora</i> ( <i>flagellated protozoa</i> ).
		<i>Sporozoa.</i>
<i>Ciliophora.</i>	{	<i>Ciliata.</i>
		<i>Suctoria.</i>

*Rhizopoda.*—To this class belongs the *Amœba coli* found in the intestine of man, and believed to be one of the causes of dysentery.

*Mastigophora.*—The flagellated protozoa have their most interesting representative in the *Trypanosomata*, a family which recently has become of the greatest importance as a cause of specific disease of both man and animals. Several species of *Trypanosoma* are known. *T. Evansi* causes 'surra,' the well-known disease of horses in India. *T. Brucei* is found in the African *Tse-tse* fly disease, and is transmissible by means of the inoculation of this fly to all domesticated animals. The fly obtains the organism from big game; the latter seem to be immune, and suffer no inconvenience from the presence of this organism in their blood. The *T. equinum* is found in South America, and is the cause of a horse disease known as 'mal de caderas'; the *T. equiperdum* has been found in Algeria and India, and is connected with the venereal disease of equines known as 'maladie du coit' or 'Dourine.' Another South African trypanosome is the *T. Theileri*, found exclusively in cattle, and causes one of the forms of so called 'gall sickness.' With the exception of *T. equiperdum*, which is communicated by coitus, all the others named are conveyed by biting insects (see p. 425).

There has recently been found a new trypanosome in the blood of horses in Gambia, which produces anæmia, and another is found in the blood of men in Central

Africa, where it causes 'sleeping sickness,' first seen in Uganda.

Some harmless trypanosomata are known to exist as parasites in the blood of some small vertebrates, batrachians, and fish.

*Sporozoa*.—The coccidia are parasites affecting the cell; they exist in two stages the result of sexual dimorphism. One stage, the *Schizogenic* is the means by which the organism multiplies within the body for the purpose of

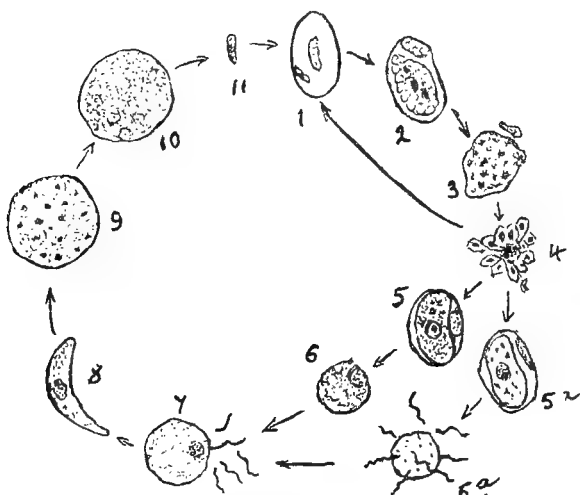

Fig. 186.—Diagram of the Cycle of Development of *Hæmoproteus*. (After Schaudim.)\*

1, Sporocysts entering the red corpuscle; 2 to 4 are the *schizogenic* stages by which the organism multiplies in the body for the further infection of the host. Within the body it never goes beyond Stage 4, and from this infects other blood corpuscles as indicated by the arrow.

Stages 5 to 11 are *sporogenic*, and serve for the reproduction of the species, 5 being the male, 5a the female element, 6 and 6a being the mature cell elements; these come together at 7, resulting in the formation of an oocyst at 8, and finally the production of a mature sporocyst at 11, which when inoculated into an animal infects the red cell. Stages 5 to 11 take place outside the animal body and within that of the intermediate host.

infecting its host (Fig. 186), the other, or *Sporogenic* stage, is a true sexual reproduction by male (*macrogamet*) and female (*microgamet*) elements, which serves not for the

\* Dr. F. Doflein, *Die Protozen*.

infection of the animal body, but solely for the reproduction of the species, and this stage only occurs in the intermediate host. The conjugation of the two elements is called the *Oocyst*, which develops the spores, hence the name of this stage.

The best known pathogenic species is the *Coccidium cunicoli* which lives in the liver of rabbits. A similar coccidium is probably the cause of the hæmorrhagic diarrhœa of cattle, described in Switzerland as '*die rote Ruhr*' or red diarrhœa. This disease is generally observed during the summer, and is attributed to the cattle grazing on fresh grass, and drinking stagnant water.

Young sheep and goats may suffer from an enteritis due to coccidiæ; dogs, cats, and poultry, are also known to be affected by this organism.

The intra-corpuseular parasites of the blood belong to this group; they are spoken of as *Hæmosporidia*, and include the parasites of human malaria, viz. *Plasmodium præcox* the cause of tropical fever; *P. vivax* found in tertian fever, and *P. malaria* found in quartan fever. A somewhat similar parasite may be found in birds, the *Hæmoproteus Danilewsky*. The schizogenic stage of this organism takes place in the blood of the host, while the sporogenic stage occurs in the body of a mosquito of the species *Culex*.

Another important genus belonging to the group of hæmosporidia, and the one which most interests us, is the *Pyroplasma*, of which the best known, perhaps, is the *P. bigeminum* the cause of Texas fever; but there are several others, all pathogenic: the *P. canis* produces malignant jaundice of the dog; the *P. equi* is the cause of biliary fever in horses, mules, and donkeys; the *P. ovis* has been discovered in the disease of sheep known in Roumania as '*carceag*'; the *P. bigeminum* causes the hæmoglobinuria of European cattle, which is probably identical with that found in Texas fever, while the formidable African Coast fever (Rhodesian redwater) of cattle, is caused by a very small pyroplasma, described by Koch as

the *Bacillary pyroplasma*, but for which the name *P. parvum* would be more suitable.

In this extremely interesting class of blood parasites, the method of infection is most important. In the case of the malarial parasite of man the life cycle is completed in the body of the mosquito, while in the genus *pyroplasma* the tick of each species of animal is the infecting agent; in some cases it is also the elaborating agent; for example, the East Coast fever of cattle cannot be produced by direct inoculation, but only by feeding ticks on the affected cases, and subsequently placing their successive stages of nymphs and adults on healthy animals (see Ticks, p. 417). By analogy with the before-mentioned parasites, we conclude that the schizogenic stage of this organism occurs in the blood, while the sporogenic stage occurs in the body of the tick.

In the muscles of certain animals *Sporozoa* are found, and are here known as *Sarcosporidia*. The *Sarco-cystis Miescheriana* is found in the muscles of the pig; *S. Bertrami* in those of the horse; *S. tenella* in the sheep; *S. Blanchardi* in the ox, more especially in the heart muscle. Sporozoa also cause disease in fish, both the barbel and carp being known to suffer.

*Ciliata*.—Ciliated infusoria are met with in the digestive canal of all domesticated animals, and are non-pathogenic. They are possibly concerned in certain physiological processes connected with digestion.

BACTERIA.—These represent a group of very low vegetable organisms, closely allied to the lowest algæ. They are classified into the following groups:

*Coccaceæ*: so called from their spherical shape.

*Bacteriaceæ*: so called from their rod shape.

*Spirillaceæ*: so called from their screw shape.

According to their method of reproduction the bacteria are further grouped:

<i>Coccaceæ</i>	{	<i>Streptococcus</i> : Cells grouped in a chain.
		<i>Sarcina</i> : Cells grouped in a cube.
		<i>Micrococcus</i> or
		<i>Staphylococcus</i> } Cells grouped irregularly.

<i>Bacteriaceæ</i>	{	<i>Bacterium</i> : No spores are produced.
	{	<i>Bacillus</i> : Spores are produced.
<i>Spirillaceæ</i>	{	<i>Vibrione</i> : A short curved cell.
	{	<i>Spirillum</i> : A long curved spiral cell.
	{	<i>Spirochæte</i> : A screw shaped cell.

Some bacteria are motile, and this is usually due to the presence of flagellæ.

The above groups of organism contain all the known pathogenic bacteria, but it is convenient here to note that all pathogenic bacteria are not visible, in fact the organisms of some of the most highly infectious diseases have never been seen, for example, rinderpest, foot and mouth disease, small-pox, sheep-pox, and pleuro-pneumonia; nor have the organisms been seen which produce such highly inoculable diseases as rabies and South African horse sickness. The organisms of the above diseases are invisible owing to their extreme minuteness, yet we know of their existence, and are sometimes able to filter them off from the fluids in which they are found; even this is not yet possible for the organism of 'horse sickness,' which passes through the pores of the finest filter.

*Coccaceæ*.—The principal representatives of this group are *Streptococcus* and *Micrococcus pyogenes* found in connection with septic processes. There is a specific disease of the horse, 'Strangles,' caused by the *Str. equi*, and a disease of cattle and goats, known as *Agalactia*, which is due to the *Str. agalactice*. In *agalactia* the organism causes atrophy of the milk cells of the mammary gland, and subsequent induration of the organ.

*Bacteriaceæ*.—This group contains several species which cause disease, viz. the bacterium of hæmorrhagic septicæmia, glanders, swine fever, and swine erysipelas, and the bacillus of anthrax, quarter-evil, tetanus, malignant œdema, and others.

*Spirillaceæ*.—In this group is found the organism of a disease resembling fowl cholera, another affecting geese and fowls and one affecting cattle, but it has not been

possible at present to cultivate these artificially. It is now thought that the Spirillæ belong to the group Sporozoa, rather than the Bacteriaceæ.

The *Streptothrices* are a connecting link between the bacteria and the moulds. By some they are not regarded as a distinct species, but as allied to the moulds. The principal organisms belonging to this group are the *Streptothrix bovis* which produces actinomycosis; the *Strp. farcinica* which causes the disease in Guadeloupe known as *mal de Guadeloupe*; the *Strp. necrophora*, found in several diseases of the domesticated animals often as a secondary infection, and commonly known as the bacterium of necrosis. It is now believed that the bacillus of tuberculosis should be classed as a *Streptothrix*, on account of the branching threads which have been observed in pure cultures, but other authorities contend these branches are simple involution forms.

Bacteria which are described as 'acid fast,' from their power of retaining acid dyes, are also described as belonging to this group.

These acid-fast bacteria are of some importance, as they have repeatedly been found in milk and may be mistaken for the real pathogenic tuberculosis microbe.

Up to lately it was accepted that the tubercle bacillus of men and animals was identical. Professor Koch, however, expressed the opinion that human tuberculosis was not inoculable in cattle, and in consequence believed the converse to be equally true. The most recent experiments show that there are certain tribes, or varieties of human tubercle which are capable of producing generalized tuberculosis in cattle.

The *Hyphomycetes* or moulds are true fungi, they consist of simple or branched filaments which bear spores, and according to the formation of the spore bearing organ so are moulds divided into *Aspergillus*, *Penicillium*, and *Mucor*.

Some fungi are pathogenic, for instance, the *Trichophyton tonsurans* and *Achorion Schönleinii* which produce ring-worm. Moulds have also been found in the bronchial tubes

and lungs where they produce a pneumonia, and another has been found in the mouth, *Oidium albicans*, where it causes 'thrush.' This latter is now considered to be a saccharomyces.

The *Blastomycetes* or *Yeasts* are connected with the moulds. To this group belong the organisms which produce alcoholic and other fermentation. A pathological organism is the *Saccharomyces farciminosus*, which produces Epizootic lymphangitis in horses, a disease which in appearance closely resembles farcy.

*Conditions of Bacterial Growth.*—Bacteria are vegetable organisms devoid of chlorophyll, and depend for their existence on organic matter; this being so it has been reasonable to consider bacteria in the light either of parasites or saprophytes. We now know that certain bacteria may derive either their carbon or nitrogen directly from the air, while others again can live on simple inorganic compounds which contain no free nitrogen. Such bacteria are found in the soil, and as nodules on the roots of leguminous plants, and their existence facilitates our conception of how nutrition was carried on when life first began on this planet.

All bacteria require water, salts, carbon, and nitrogen. The pathogenic bacteria prefer an alkaline or neutral medium to grow in, while the moulds prefer one which is acid.

Some bacteria require oxygen for their growth and are known as *aerobes*, others can only live in the absence of oxygen, *anaerobes*, while still a third group can live either with or without oxygen. Thus there are obligatory aerobes and obligatory anaerobes, facultative aerobes and facultative anaerobes. Heat is necessary for the development of bacteria, and it is found that all pathogenic bacteria thrive best at the temperature of the animal's body. Most, but not all, bacteria may be cultivated artificially apart from the body by providing the necessary atmosphere, nutriment, and heat. It is found experimentally that by altering the temperature at which an organism grows, changes may occur in its virulence, and advantage is taken of this fact in preparing attenuated viruses.

Light is as a rule unfavourable to the growth of bacteria, and direct sunlight frequently kills them. Destruction may also be produced by certain chemical agents, and this is the basis of disinfection. Finally, the growth of bacteria may be influenced by the products of their own metabolism, or by the presence of other species of micro-organisms.

*Products of Bacterial Growth.*—According to the biological conditions under which organisms work they may be classified under three heads.

1. *Prototrophic bacteria* are characterized by their synthetic tendency, whereby they build up chemical compounds out of simple elements. The best examples of this are the nitrogen bacteria on the roots of leguminous plants (p. 389), and the nitrifying bacteria of soils (p. 391).

2. *Metatrophic bacteria* are characterized by their work being chiefly of an analytical character, by which they break up organic compounds, both nitrogenous or non-nitrogenous. An example of the former is the process of putrefaction (saprogenic bacteria), and of the latter the process of fermentation (zymogenic bacteria).

A third group of bacteria (the Saprophile) live principally on the material decomposed by the saprogenic or zymogenic organisms.

Saprogenic bacteria break down the complex proteid molecule by means of enzymes (proteolytic enzymes, trypsines), and in this way resemble the process of digestion. The final products are nitrogen, ammonia, carbonic acid, sulphuretted hydrogen, etc. Finally, these simple substances under the influence of the paratrophic bacteria are rendered available as plant food, and thus their cycle begins afresh.

In a similar way organic matter which contains no nitrogen is also broken down; the carbo-hydrate molecule is attacked by enzymes, the final product being chiefly carbonic acid. The breaking down of insoluble molecules is preceded by their being changed into soluble molecules by means of enzymes (invertin, maltose, etc.).

The biological group of pigment bacteria produce pig-



ments, while the photobacteria possess phosphorescent properties.

3. *Paratrophic bacteria* are true (*obligatory*) parasites which can only exist in living animals, and under natural conditions do not develop outside the body. Some of them may be cultivated under certain conditions and on suitable material. They act chiefly by their toxins, the chemical nature of which has not yet been determined. Soluble toxins may be excreted by the living organism, while others keep to the cell and only escape after its death; such extractive poisons are *Tuberculin* and *Mallein*.

#### INFECTION.

Pathogenic organisms are either *obligatory* parasites—viz., can only exist in living animals, for example glanders—or *facultative* parasites—viz., capable of growing outside the body, such as the microbe of quarter-evil. The latter class of parasites live in a metatrophic way, and when they gain access to the body may develop there.

*Saprophytes* live on dead organic matter. It is possible that saprophytes may acquire pathogenic properties, just as, on the other hand, pathogenic bacteria may lose their virulence and live as saprophytes. As a rule saprophytes are harmless, notwithstanding which the products of some of them may be pathogenic when they gain access to the body.

Saprophytes may be so altered artificially as to grow as parasites. A good example of this is the saprophytic bacterium of potatoes, *B. megatherium*, which under ordinary circumstances is harmless, but may, by being grown in a collodion bag in the abdomen of the guinea-pig, be converted into a pathogenic organism capable of killing the same animal.

This experiment explains that pathogenic bacteria may at one time have been saprophytes, and owing to the adaptability become true parasites. Conversely, it is possible to tame some highly pathogenic organisms, as for instance *B. anthracis*, so as to acquire purely saprophytic habits.

The effect of pathogenic bacteria on the system is due either to their development in the tissues or to the absorption of their toxins. The soluble toxins readily enter the system, the insoluble ones escape only with the disintegration of the cell.

Certain bacteria act chiefly by their toxins; others are not able to live in the tissues though their toxins are very fatal. Some bacteria can live in wounds but do not invade the tissues, though their toxin does, and this latter produces death by poisoning, as for example, the bacillus of tetanus; other bacteria can only cause a circumscribed pathological condition, and this is brought about by the toxin being absorbed by the adjoining cells.

The toxin of all pathogenic microbes is not known, but they are all assumed to exist. Death by microbial infection may be due to the action of toxin, occasionally to the bacteria withdrawing nutriment from the tissues, and frequently to the mechanical effect of the organisms in blocking the capillary vessels; probably in most cases two or more of these influences are at work.

The pathogenic effect of a bacterium depends upon varying conditions, the principal one being its virulence, while the latter depends upon its toxic effect and reproduction. The virulence of an organism is a varying factor easily influenced by several causes, for instance, the amount of the virus and the method of its application.

Some bacteria are increased in virulence by being mixed with harmless bacteria; others become pathogenic by chemical or mechanical alterations in the tissues, and some will only grow when a suitable condition of body has been produced by a prior infection.

The development of two or more organisms in the body is termed a mixed infection; successive infections by the same organisms are called secondary infections.

Infection may result through wounds, inhalation, food, water, bites of insects, and coitus.

Infection may be direct, and this is the most common condition; in some diseases it is indirect, the organism

having to pass through the body of an intermediate host, and a still further complication exists when it is not the intermediate host but only its progeny which can give the disease. As an example of direct inoculation we may quote anthrax or glanders; of infection through an intermediate host we have trypanosomata diseases; while of infection through the progeny of the intermediate host we have all the piroplasmoses.

### IMMUNITY.

Immunity is the ability of an individual or species to resist infection. The resistance offered may either be against the organisms or against their toxins.

Immunity is *natural* or *acquired*. Natural immunity is either *complete* or *relative*; acquired immunity may be *active* or *passive*. There are two modern theories which endeavour to explain the interesting practical phenomenon of immunity.

#### A. Antitoxic Serum.

1. *Ehrlich's Lateral Chain Theory*.—An animal susceptible to a certain toxin, may be made highly immune by gradually increasing the quantities of toxin injected, and the blood serum of such an animal by this process of hyper-immunisation, acquires properties which neutralize the action of the toxin; the serum is therefore termed antitoxic, and the antitoxic effect on the poison can be produced either within the body or *in vitro*.

It is believed that the neutralization thus produced is a chemical one, for it follows the law of chemical combination that certain definite amounts of antitoxin are required to neutralize certain definite amounts of toxin.

Ehrlich considers that a toxin molecule possesses two groups.

(1) A stable group described as the *haptophore*, which attaches itself to a certain unstable or lateral group in the animal cell (Fig. 187, p. 460).

(2) An unstable group known as the *toxophore* (Fig. 187),

which sets up the toxic action. The toxophore group may be easily influenced whereby it loses its toxic properties, and such a molecule is termed *toxoid*.

In the same way the animal cell is considered to have,

1. A stable central group.
2. Unstable lateral groups.

The stable toxin group or haptophore attaches itself to the unstable lateral groups of the animal cell, while the unstable, or toxophore group of the toxin in this way gains access to the cell, which may mean its entire destruction.

Thus the animal cell is likened to a side chain of atoms in organic chemistry. These side, or lateral chains, also called 'receptors' (Fig. 187), under physiological conditions are concerned with the assimilation of food, and are a necessary condition for the nutrition of the cell.

Under pathological conditions it is believed that the haptophore group in the toxin is anchored or fixed to these lateral chains, hence they are called *receptors*. The toxin molecule being brought in contact with the cell, its toxophoric group is now able to set up disturbances in the protoplasm of the cell substance.

By the union of the haptophore group of the toxin molecule with the lateral chains of the cell, the side chains only are destroyed, while the cell substance (the central group), is unaffected and forms fresh lateral chains, which accumulate in the general circulation. In fact an excess of compensation occurs, which means an excess of 'receptors,' which floating in the blood stream form the antitoxin, and by laying hold of the toxin molecule, and uniting with its haptophore group, prevents it from attacking the cell substance.

If a toxin and its antitoxin be injected into the blood at the same time, the 'receptors' pass into chemical combination with the haptophore group of the toxin molecule, and a passive immunity is obtained which only lasts as long as the side chains are present in the circulation.

Natural immunity may be regarded as due to there being

no appropriate receptors for the haptophore group of the toxin molecule, and where these are absent no attack on the cell protoplasm is possible.

*B. Anti-bacterial Serum.*

Immunity may be produced by the injection of *Anti-bacterial Serum* which is obtained by hyper-immunising an animal with bacteria; by this means the blood serum acquires properties which when injected will protect another animal from a poisonous dose of bacteria. Such a serum is described as preventive, and it can be studied outside the body, for on the addition of such serum to the microbes the latter may be destroyed.

No such destruction takes place, if prior to the addition of the serum to the microbe it be heated to a temperature of 55° C.; but the destroying action can be reproduced by adding to it the fresh serum of an animal of the same species which has not been immunised. From this it follows that to produce the destructive effect two substances are necessary, one stable which is not destroyed and one unstable which is destroyed by heating to 55° C. The stable substance is called,

By Ehrlich the '*Amboceptor*.'

By Bordet the '*Substance sensibilisatrice*.'

By Metchnikoff the '*fixateur*.'

The unstable substance is called,

By Ehrlich the '*complement*.'

By Bordet the '*alexin*.'

By Metchnikoff the '*cytasis*.'

Ehrlich explains the destructive action of this serum on bacteria by his lateral chain theory: he assumes that under the repeated injection of bacteria the body cell casts off a 'receptor' which is composed of two groups:

1. A *cytophile* group.
2. A *complementophile* group.

Effect of the anti-bodies on the soluble products of cells (Toxins), or on the cells themselves.

Cast-off free Receptors (Haptines).

Effect of the Immunising Substance on the Receptors of the 1st, 2nd, and 3rd Order of Body Cells.

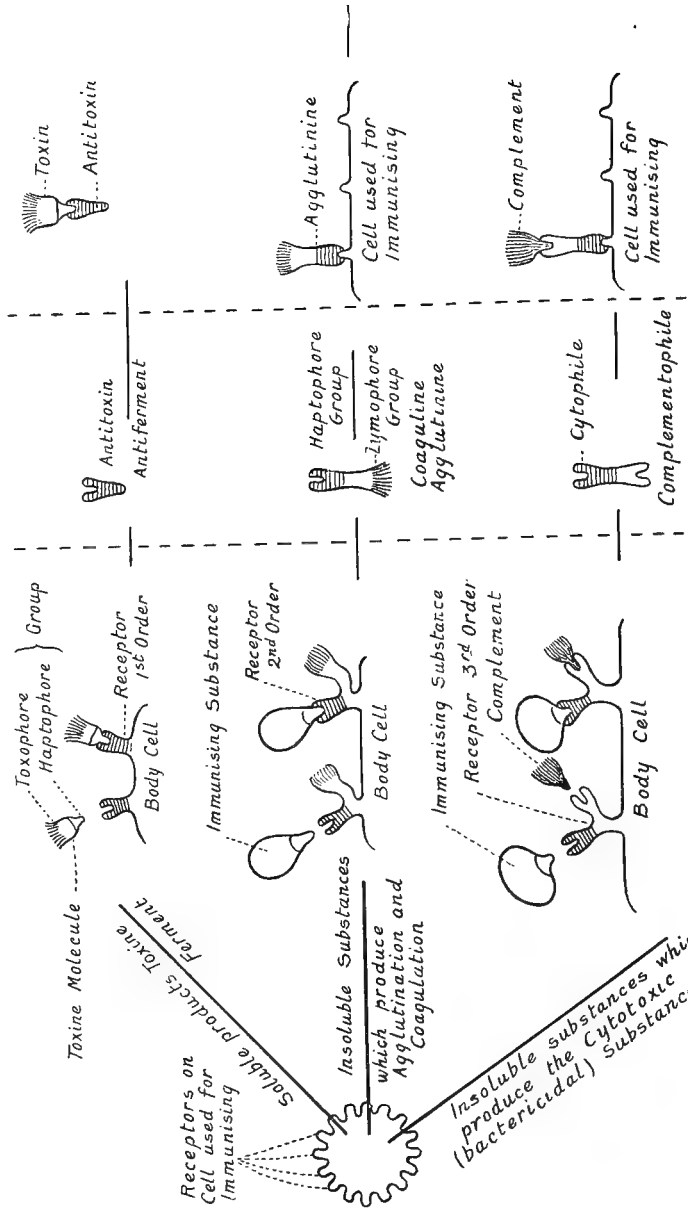

Fig. 187.—Diagram of Ehrlich's Side Chain Theory of Immunity (Dr. L. Aschoff).

These two-grouped 'receptors,' now called 'amboceptors' (Fig. 187), after becoming detached from the cell, link up with the bacteria in the following way:—viz. the cytophile group joins on to the bacteria, while the complementophile group unites with the complemental substance which is constantly present in the serum of normal animals, and acts as a ferment for the destruction of the bacterium now linked to it.

In this way the bacterium cannot reach the protoplasm of the cell, and the immunity is known as passive.

Ehrlich considers active immunity to be due to the co-operation of these two substances, viz. the amboceptors and the complement, and he calls a bactericidal serum 'complex' which always has these two substances present in it.

The production of a preventive serum is not only observed after injecting bacteria, but after injecting any cell material derived from animals; for instance, the red corpuscles of species A if injected into species B, produce in B a serum which dissolves the red corpuscles of A. This serum behaves exactly as the anti-bacteric, and it also consists of two substances. Such a serum is termed cytotoxic, or in the example given above hæmolytic.

The hyperproduction of amboceptors is according to Ehrlich nothing else but a normal function of the nutrition of the cell, and the immunity it produces is therefore only one of its particular duties.

*Agglutination.*—By the injection of bacteria or cells into an animal, an 'anti-body' is produced which agglutinates the bacteria, so that if added *in vitro* to a corresponding culture of bacteria, the latter collect in flocculi and sink to the bottom of the glass.

This reaction is used for diagnostic purposes, and permits the identification of a species of unknown bacteria by a serum produced by known bacteria; further, it serves for the diagnosis of disease, the phenomenon being known as agglutination.

*Precipitines* are another form of anti-body, for example,

milk may be coagulated by the addition of blood serum, taken from an animal into the circulation of which milk has previously been injected. If the blood serum of an animal be repeatedly injected into another of a different species, a serum is obtained which precipitates the serum of the animal which previously furnished the material, and this method has been used for the detection of blood and flesh of different animals.

'Agglutinins' and 'Precipitins' are a third variety of 'receptor' produced by the living cells, but are distinguished by having attached to their haptophore element a zymophore or ferment group (Fig. 187); this latter acts through the former, and produces agglutination or precipitation.

We have now considered the three groups or *Haptines* of lateral chains, and may present them in the form tabulated by Ehrlich:

(1) <i>Haptines of the</i>	}	<i>Uniceptors</i>	{	<i>First Order</i>	Antitoxins.
(2) <i>Haptines of the</i>				<i>Second Order</i>	Agglutinins, precipitins.
(3) <i>Haptines of the</i>	}	<i>Amboceptors</i>	{	<i>Third Order</i>	Preventive serum.
					Hæmolytic     ,,
					Cyto-toxic     ,,

2. *Metchnikoff's Phagocyte Theory of Immunity.*—Phagocytes are certain fixed or mobile cells (leucocytes), found in all the tissues of the body, which possess the power of attacking, destroying, and ingesting foreign particles which may enter the system. There are two kinds of phagocytes (1) *Makrophages* (mononuclear cells) which principally attack cells of animal origin, and (2) *Mikrophages* (polynuclear cells) which are chiefly directed against bacteria. The phagocyte possesses the power of engulfing the living cells and completely digesting them.

Phagocytes are guided towards the invading matter by what is known as *chemiotaxis*, viz. the attraction on the leucocytes of some chemical substance in the disease germs, and such a condition of chemiotaxis is spoken of as *positive*;



sometimes the chemical substance exercises a repelling effect on the phagocyte, and this is known as *negative chemiotaxis*.

According to this theory natural immunity is due to active chemiotaxis, the invading material being engulfed and digested; when however this fails to occur through the existence of negative chemiotaxis, infection results.

The action of a preventive serum in the body is due to increased positive chemiotaxis, the result of the co-operation of two ferments in the serum. One of these, the '*fixateur*,' is contained in the liquid blood and acts on the bacteria for the phagocyte to deal with, while the other ferment, known as *cytasis*, is contained within the bodies of the phagocytes from which it only escapes after the coagulation of the blood (bactericidal serum).

Bacterial immunity accordingly represents nothing else but an example of intra-cellular digestion.

Natural and acquired immunity against toxins are according to Metchnikoff due to some vital influence of certain cells, which prevent the attack of the toxins on susceptible cells.

In the case of acquired immunity probably macrophages form the principal source of antitoxins, and these in the living body act in a similar way to the '*fixateur*' in the case of bacteria.

The essential difference between the two theories of infection and immunity, of which we have given only a mere outline, is that, while Erlich considers the destruction as taking place in the liquid blood, Metchnikoff regards it as occurring in the phagocytic cells.

Metchnikoff's theory is essentially vital, Ehrlich's essentially chemical.

*Methods of Producing Immunity.*—These will be dealt with in sufficient detail in considering the various infectious diseases, but we may here conveniently classify the methods which are of practical value in dealing with animal diseases.

*Methods of Producing Active Immunity.*

1. Immunity may be produced by the inoculation of a pure virus; for example, pleuro-pneumonia and sheep-pox.

2. By attenuated virus obtained by heating and drying; for example, anthrax, quarter-evil and rabies.

3. Attenuated virus obtained by passing it through other animals; for instance, swine erysipelas, and tuberculosis (?).

4. By attenuation from unknown causes, of the virus occurring in the body of the sick or recovered animal; for example, rinderpest bile, and the blood of recovered cases of Texas fever.

5. By sero-virus inoculation, either simultaneously or successively mixed; for example, rinderpest, swine erysipelas, sheep-pox, quarter-evil, malarial catarrhal fever of South African sheep, and South African horse sickness.

*Methods of Obtaining Passive Immunity.*

The production of passive immunity is a valuable therapeutic measure, in those diseases in which the organisms cannot live long apart from the animal body; for example rinderpest, where the virus scarcely lives three days apart from the body. Passive immunity may be produced by the injection of varying quantities of serum taken from an immunised animal. Large quantities have to be employed, but this measure tides over the critical period, and saves the remaining animals of the herd from getting infected. Much the same procedure may be used in sheep-pox when the outbreaks are isolated; it has also been suggested for foot and mouth disease, and swine plague (Schweineseuche).\*

For the latter disease a *polyvalent serum* is employed made by injecting into the animal to be immunised several

\* This is not the swine fever of Britain.

strains of the bacilli, as it is found from experience these are frequently of different degrees of virulence.

Finally, the injection of serum, for the prevention of tetanus among horses which have to be operated upon in notorious tetanus localities, is a measure which may be adopted, the serum in this case being a pure anti-toxin.

CHAPTER XI  
STATE HYGIENE

*SECTION I.—INFECTIOUS AND CONTAGIOUS  
DISEASES.*

LEGISLATION.

THE story of legislation in Great Britain against infectious and contagious animal diseases, is one which inspires very little enthusiasm in the student of history. From beginning to end it is marred by that barrier to all progress—viz. ignorant public opinion. It is one long fight between either conservative ignorance or official incompetence. Even now this has not entirely changed, and the Ministers of to-day hesitate and doubt in much the same way as they did forty years ago, not because they have any reasonable doubt in their minds as to the right course to pursue, but because of the probable political effect of their legislation.

The invasion of England by Cattle Plague, from which may date our modern system of legislation for epizootic diseases, need never have occurred had the Ministry been guided by the advice of a veterinary surgeon who was half a century in advance of his day—viz. John Gamgee. He foresaw and foretold what must happen unless the importation of live stock was forbidden from the Continent of Europe, where Cattle Plague was then rampant. A deaf ear was turned to this advice, because the representatives of the import cattle trade were too powerful, in spite of the fact that legislative enactments existed without asking any further powers from Parliament.

Gamgee's predictions in course of time proved true, but even then his advice to destroy the affected and in-contact cases was not followed, as its suggestion raised the most intense ill-feeling throughout the country; yet finally, after importing medical and lay advice, the measures suggested by him had to be enforced by Parliament, in order to free the country from disease.

Gamgee warned the authorities what must occur nine years before the disease appeared in England, yet it found us utterly unprepared for the invasion. No veterinary staff existed to advise the Government, no machinery for the suppression of disease, everything left to the policy of drift and muddle, national characteristics which have become intensified rather than reduced by time and experience. In spite of years of warning, when the country cried out for the Government to act in the matter of Cattle Plague, the only reply at first received was that they had not sufficient power to deal with it!\* Now, as a matter of fact, they had powers but they were not exercised. An Act of 1848, known as 11 and 12 Vic., Cap. cv., gave the Privy Council power to prohibit the importation of cattle, sheep, and other animals, or only to admit them after quarantine. Act 11 and 12 Vic., Cap. cvii., of the same year as the above, gave power to prohibit and regulate the movements of animals in the country, also that of hides, fodder, or anything capable of spreading contagion, and when in 1853 Act 16 and 17, Cap. lxii., took the place of the above, the same provisions were enacted, including others dealing with the exposure of diseased animals in markets and on commons.

So that the excuse of having no power is not correct. They had the powers but were afraid to utilise them; they had the advice but were too timid to act upon it.

A Cattle Plague Department hurriedly formed in 1865 was the nucleus of the present Veterinary Department of

\* See a most interesting account on the 'Progress of Legislation against Contagious Diseases of Live Stock,' by Mr. J. Duckham, M.P., *Journal of the Royal Agricultural Society*, vol. iv., part ii., 1893.

the Board of Agriculture. It consisted of Professors Simmonds and Brown, with Dr. Williams as 'Medical Adviser,' and Colonel Harness, R.E., as Secretary. But the Privy Council was in a hopeless condition, it issued orders in rapid succession which were neither understood nor acted upon, and finally appealed for a Royal Commission to investigate the disease (Duckham).

The Royal Commission, of which only *one* member was a Veterinary Surgeon, confirmed the opinion of the veterinary experts as to the necessity for destruction, which advice had caused a perfect storm in the agricultural world, in which the whole veterinary profession was held up to ridicule and unmeasured insults. The same Commission also recommended the stoppage of all cattle traffic in the country, and placed this matter in the hands of the local authorities to carry out, with disastrous results.

At last the country becoming alarmed at the impotence of the Government sent many deputations, and finally held a great national conference in St. James's Hall, which led to the passing of the Cattle Diseases Prevention Bill in 1866; the same year saw the formation of the Chamber of Agriculture, the pressure of which finally produced a Minister and Board of Agriculture, to safeguard the flocks and herds of the country.

The only object in raking up a chapter in history now almost forgotten, is to explain that we have gained very little by bitter experience, for an old nation is like an old man, narrow, conservative, and unable to learn; hence the reason why there are still diseases in our midst that legislation could control to-morrow, and others where the legislation or its machinery is so defective, that little impression is made on the diseases against which they are enforced.

Legislation to exterminate animal plagues must be thorough, half measures are useless. No one expects a Minister of Agriculture to understand pathology, bacteriology, or hygiene,\* but he is furnished with the best

\* In spite of this, within the last two years, a Minister of Agriculture has ventured to lecture on the spontaneous origin of contagious

expert advice the country can produce ; on it he should act, and by it the Government should be prepared to stand or fall. But Governments like individuals are selfish, and the idea of loss of power is most repugnant, so that half-hearted suppressive measures come into force which irritate, do no good, and are turned over to the Local Authorities to carry out, who, if it suits their purpose, evade them as far as possible.

But we must also look at the other side of the question. A Government exercising a policy of benevolent despotism is obnoxious to our constitution ; the Government exists by the will of the people, so that those who urge the education of the masses rather than that of the Government have much on their side. In fact, it has been claimed that the repressive measures enforced by the State in connection with epizootics, have always been in advance of public opinion. However this may be, and there is good reason for believing that examples are not wanting, it shows how necessary it is that public opinion should be educated, and possibly it would be if we fully realized the importance of teaching the history of our own country in schools, and allowed the dead languages to lie in the natural grave they have dug for themselves.

We have not touched on the financial aspect of enlightened legislation, though whenever values can be expressed in actual money they generally appeal to popular imagination and common-sense. It has been estimated that hundreds of millions represent the loss which this country has sustained through the ravages of imported diseases, and we may as well here note, that the large majority of epizootics affecting our flocks and herds have been imported from abroad, and are not natural to this country.

The earliest act of legislation recorded was directed against scabies in sheep in the year 1798, but very little

---

disease, and reflected on the ignorance of the veterinary profession in not recognising this important factor.

attention seems to have been paid to it. At any rate the disease still exists, and the country doubtless has never been free; half-hearted legislation extending over a hundred years has not been of much service.

From 1833 to 1842 existed an Act known as 3 and 4 William IV., Cap. 52, which prohibited the importation into England and Ireland of cattle, sheep, and swine from abroad. It was cancelled in 1842, and an import duty took its place, which was imposed until 1846, when it was removed.

In 1847 sheep-pox was imported from Denmark. It spread over the greater part of the country, affecting tens of thousands of animals, and causing a mortality of 90 per cent. It took three years to rid the country of this plague, and public interest was aroused in the matter, with the result that the Acts of 1848 and subsequently of 1853, which we have previously alluded to, were made, but were either not utilized or only in a spasmodic manner. It was in the Act of 1853 that the first attempt to legislate against glanders occurs.

It has been said that the neglect to put in force existing legislative measures was due to the ignorance of the public on these questions, a public which regarded pleuro-pneumonia as non-infectious, and foot and mouth disease as a simple complaint bearing the same significance as measles in the human subject.\*

In 1866 was introduced the Cattle Diseases Prevention Act, the outcome of cattle plague, and the result of pressure put upon the Government by deputation after deputation of agriculturists, whose ignorance had become enlightened by their bitter experience of the disease. So strong was the pressure, that the Government passed this Bill through the House with the utmost rapidity and in thirteen days it became law.

From this Act of 1866 all our modern legislative machinery is derived. It could not be expected that perfectly compre-

\* Professor G. T. Brown, *Journal of the Royal Agricultural Society*, vol. iv., part ii., 1893.



hensive laws could at once be framed to cover years of neglect, and as time rolled by successive Acts have appeared, improving upon former methods, and rendering prevention and suppression more complete. It is, however, astonishing to find that after the bitter years of 1865-66 any Government could be found permitting foreign cattle to be again admitted from infected countries, but such was the case, and foot and mouth disease (which the cattle plague regulations had nearly abolished) and cattle plague were both again introduced into the country!

The further history of legislation it is unnecessary to follow; our object in briefly reviewing the past is to show how it explains the present, and to indicate what should be the action in future.

*Local Authorities, Permissive Legislation, and Lay Inspectors.*—In all the Acts directed against disease up to date, the most serious blot made in their construction is placing their administration in the hands of the local instead of the central authority. It is not the slightest use drawing up stringent regulations and placing them in the hands of people to administer who are opposed to legislative interference, and do not understand the value of the immense powers given them. It is these half-measures which prove costly failures; they are well exemplified by such puerile legislation as muzzling the dogs in one county and not in those which are adjacent to it. It seems inconceivable that our national common-sense should have completely failed us when hysterical men and women cried out about muzzling. The dread of becoming unpopular and losing votes is such, that measures which the Ministers know to be right have to give way under the pressure of public ignorance.

The utter selfishness of dog owners in the matter of rabies is what most impresses the observer; as many as sixty people may die in a year from hydrophobia—the most dreadful of all deaths—but that is to be no excuse for putting the pet dog's head in a cage when it goes out for a walk! There is only one way of dealing with such, and that is a strong Govern-

ment that knows its own mind, and intends to carry out the best measures for the good of the country, and stand or fall by them ; fortunately such a one was finally found, and rabies has become extinct.

Leaving this question, we must examine the machinery which exists for carrying out measures which are decided upon, and here it may at once be stated that orders are frequently permissive, and left to the judgment and intelligence of the local authority.

This is a radical defect. There should be no such thing as permissive legislation ; an Act is required or it is not. If it is required it must be applied, and the people to apply it are not those who are affected by it, but the impartial Central Authority who knows the nature of the measure.

Permissive legislation has also another aspect ; it produces discontent and irritation. One local authority is particular and carries out the law, another is slack and evades it ; one gives compensation, the other refuses it ; one will disinfect and clean a place at the expense of the rates, another lets this fall on the shoulders of the owner. In other words, there is no uniformity, and without this the results can never be good.

The Board of Agriculture, as the Central Authority and representative of the Government should issue an order to the Local Authorities, direct them to carry it out, and, further, take steps to insure this is done. The instructions of the Central to the Local Authorities must be of the nature of 'shall,' and not as at present 'may,' the Local Authority being merely the machinery on the spot for carrying out and enforcing the law. The intelligence of the Local Authority is not equal to the responsibilities imposed on them, while their feuds with neighbouring authorities, which seem part of the established programme of municipal life, are not conducive to effective legislation.

For the purpose of legislating against epizootic diseases, Great Britain should be one large county from a legal point of view, while the existence of boundary marks must, for the public good, be forgotten.

All this assumes that the Central Authority is equal to the task it has in hand, and that its organization is such that it is safe from criticism. But this is not so. In some extraordinary way, probably caused in the first instance by the panic and rush produced by Cattle Plague, laymen with no previous training fill some of the most important offices in the Board. It is inconceivably astounding that a man ignorant of pathology, bacteriology, and hygiene, can be placed in the position of combating animal diseases! To these lay inspectors some of the work requiring the most acute powers of observation and reasoning falls—reasoning which can only be based on a knowledge of the technical subjects above mentioned, to make no reference to a knowledge of animals, their habits and peculiarities.

There is nothing in the whole range of preventive medicine which requires a more highly-trained mind than tracking down disease, running it to its source, determining the cause of infection, the channels through which it has entered, and weighing, as a well-trained mind should, the whole facts of the case for and against, and arriving at a just conclusion.

What can a layman know about this? What does he understand about microbes; their method of growth and spread, their vitality, their extreme minuteness? What does he understand about disinfection, excepting that it is a something based on the application of the Board's white-wash? What does he know of disease, its method of spread, the difficulties and niceties of diagnosis? How can such a man examine into and trace an outbreak of disease when the very elements necessary for this are denied him? Yet from the Board of Agriculture to the Local Authorities laymen are employed to do highly specialized work, with the results only too well known.\*

\* Within the last two years the Board has been compelled to engage a few specialists for this work. They have now 18 permanent Veterinary Inspectors, and 72 Veterinary Surgeons in private practice are formally Inspectors, and receive a retaining fee. These 97 experts look after 95 administrative counties in Great Britain, and the welfare of 6,700,000 cattle, 25,600,000 sheep, and 2,700,000 swine!

Take a concrete case, an outbreak of swine fever. An inquiry into this may be conducted by a person with no knowledge of pigs or disease. He is responsible for the thorough disinfection of the place, and yet is ignorant of the principles of disinfection because he has no training. Whitewash and closing the premises comprise his action in the matter, while to discuss the question of an inquiry into the disease, how it got on the farm or into the district, how many other farms are probably infected in consequence of certain sales, etc., are matters of no importance from his point of view, and yet these constitute the essence of effective control.\*

The action from the Board of Agriculture to the Local Authorities is based on these methods of lay control, tempered here and there by skilled advice, which they are not compelled to follow.

Swine Fever is not controlled for many reasons, all of which are questions which entirely come under the layman. He is responsible for the diagnosis of the disease, and here the dictum of the policeman carries more weight than the opinion of the expert. He is responsible for the thorough disinfection of the affected place, but does not realize what disinfection means from the point of view of the pathologist, and it is doubtful whether he believes a non-disinfected place the size of a thumb-print, or less, may start the whole disease afresh.

The layman gives a license for movements under the Market and Fair (Swine Fever) Order. He can allow pigs to be taken to any part of an area not prohibited; he is appointed by the local authority as a 'fit and proper person' to determine whether pigs exposed for sale have swine fever, and is allowed to give them a permit in the form of a movement license to carry the disease about with them, should his unskilled diagnosis be at fault.

As a matter of fact, the profession knows only too well

\* This is now partly remedied by the introduction of the few experts just mentioned.

the difficulties in diagnosis that some cases present, but no difficulties can ever arise with the ignorant!

Swine Fever can never be exterminated by the Board so long as it works with laymen, and this lesson it has taken them many years to learn; the money spent on compensation\* might, so far as getting rid of the disease is concerned, have been put into the sea. This the authorities are themselves realizing, for destructions are greatly reduced, and consequently compensation not given.

The country can make up its mind that in veterinary as in other matters the trained man is always immeasurably superior to the amateur, and that no effective veterinary service can exist in which the prime movers in the machine are laymen. It is difficult to see where the economy comes in of losing hundreds of thousands of pounds on an outbreak of disease, and starving the veterinary service by giving it laymen to work with instead of the expert.

The Royal Commission on Tuberculosis was astonished to find that the meat inspectors of this country consisted of conductors of the tramway, carpenters, plumbers, stone-masons, bricklayers, florists, printers, and school teachers! What would a Royal Commission think if a public enquiry revealed the fact that the most important measures for the suppression of animal diseases in this country were left to the judgment of men equally as ignorant of the matter as the above! The failure to eradicate swine fever would at any rate be explained.

In no other country would such a constitution be tolerated. Ireland, with special powers to employ laymen, rightly refuses to have them.

Some of the best veterinary advice and ability in Europe is available for the Board of Agriculture, but instead of exclusively employing it, they choose men without specialized knowledge or training, even to the extent of furnishing a Parliamentary Report on Animal Diseases!

*Weak Points in the 'Act' and Orders of the Board of Agriculture.*—We shall presently examine the Act of

\* It spent £600,000 between 1893 and 1902!

Parliament under which animal diseases are controlled, but it is here convenient to draw attention to the weakness of some of the Orders issued under the Act, and especially those which refer to disinfection. For Cattle Plague it is considered sufficient to use soap and water for the hands, and an unnamed disinfectant of no strength for the boots and clothes. For Pleuro-pneumonia there are no instructions laid down. The virus of Foot and Mouth disease is disinfected by water and lime wash. For Sheep Scabies scouring is to be adopted and lime wash, with freshly prepared lime, '*or some other disinfectant approved by the Inspector,*' who may be a cobbler. It was not until the Swine Fever Order of 1894 was published that carbolic acid as a disinfectant was mentioned, and here for the first time it is laid down that an infected market or similar place can only be declared disinfected by a *Veterinary Inspector*. Under the Swine Fever Order of 1901 it is directed that excreta, litter, etc., are to be mixed with quicklime and 'effectually removed' from contact with swine.

There is every loophole here for leakage; bearing in mind that the disease is largely spread by excreta, something more than the layman's idea of effectual removal is needed. It would have simplified matters to have said that it was to be burned, and thus have left no excuse for dealing with it in any other way.

In glanders the Local Authorities prescribe their own disinfectant, but, except in markets and horse repositories, it is not applied under any supervision; in the latter case a *Veterinary Inspector's* certificate is required. The Board prescribes water scouring and lime-wash for floats or vans used in conveying diseased horses, but stables are left to the Local Authorities who have the power to leave them to the owners.

On the other hand, in Anthrax the most careful, almost minute instructions for disinfection are given; the work has to be carried out under the direction of an Inspector (layman); for the first time hot water is prescribed for washing; freshly burned lime as a wash mixed with chloride of lime

or carbolic acid is prescribed, and their proportions for use given. In this disease the dung and litter, which possibly do not contain a single anthrax organism, is to be burned (and rightly so), while the swine fever excreta teeming with organisms is only mixed with lime and 'effectually removed'!

The whole question of disinfection in these Orders, excepting that referring to Anthrax, requires recasting. In every case the work should be carried out under the supervision of a veterinary inspector. Whitewash should no longer be regarded as a disinfectant, but relegated to the closing work of making the place look clean, after the organisms have been destroyed by a disinfectant.

The burial of diseased animals is another feature that requires revision. Six clear feet under the earth with some lime or other 'suitable disinfectant' is generally prescribed throughout all the Orders. Even the rabid dog is to be put down six clear feet! It is not said what is to be done when rock or water are met with at much less than that depth. There is no mention in the Orders of field cremation, which is perfectly simple in any country place, and not necessary in any town, where destructors should always exist.\*

It is only in the case of anthrax that detailed instructions exist as to what constitutes a 'sufficiency' of lime in burial, and here it lays down that it should be quicklime a foot thick under the body, and another foot in thickness over it—that is to say, about two tons of lime. It would be interesting to know how often this Order has been enforced.

*Compensation.*—Another question dealt with in the Act is that of compulsory destruction of diseased and in-contact animals with compensation. The question of compensation is a very vexed one; our personal views are that it is an indefensible practice, and like any form of State charity is liable to extreme abuse, fostering that spirit of looking to the State for help when it ought to come from within.

\* In 1901 a leaflet on Field Cremation was issued by the Board to Local Authorities asking them to try it.

Still, if compensation is regarded as a right thing, it should be Imperial, and not out of the local rates; the latter enactment only defeats itself when the people who have to pay are the people who make the regulations, with the result that there is no uniformity and often great hardship.

The alternative to State compensation is insurance, but as a man will not insure his life to save his family from poverty, nor make provision for his old age, it is perhaps too much to expect that he will insure himself against loss through his animals suffering from a contagious disease. We recognise the difficulties of overcoming our national improvidence, but it does not alter what we believe to be the guiding principle to be followed. This question will, however, be examined again later on.

*Restrictions on Movements.*—If the terms of the Act and the Orders thereon were followed out with any degree of exactitude, the spread of disease would be almost an impossibility. It is here the veterinary portion of the Board is in evidence in the framing of regulations. The restrictions are most severe, and rightly so; but there is no machinery on the spot excepting that of the constable and lay inspector for carrying them out. The result is that though in this respect they are models of legislation, they are rendered practically useless, either by their being permissive, or by the power of Local Authorities to mar their most important features, and their right to employ untrained men to put them into execution.

Even the Central Authority with its machinery at hand moves slowly. Their delay in imposing restrictions on the movement of swine in an affected area has at times been extraordinary. In the words of McFadyean, 'the guiding principle (of the Board) appears to be, figuratively speaking, to allow the disease a good start before imposing any restrictions on movement.\*' On this point there has been improvement recently.

There is no power, within the full control of the Local and

\* *Journal of Comparative Pathology*, vol. xv., part i.



Central Authority, so valuable for the control and obliteration of disease as restrictions on the movement of animals.

Carried out effectively by a Central Authority, with no loophole for permissive legislation, the spread of disease both in theory and practice is impossible.

Like all other measures it must be thorough; no sentiment must enter into the question, local hardships may be great, financial losses heavy, but a deaf ear must be turned to all these; the larger question of the country's good must always be the guiding principle.

It is quite painful to read the annual reports of the Assistant Secretary, Animals' Division, Board of Agriculture, in which he deplors the absence of public spirit among stock owners, the inefficiency and blindness of the Local Authorities, the slackness of the police in carrying out the Board's orders regarding the restriction of movements, and the nominal fines imposed by the Bench for breaking regulations. And yet the Board have powers granted by Parliament which would bring the whole of the Local Authorities in Great Britain into line in a few weeks, if they were exercised. The Act of 1894 has only to be read in this connection. Local Authorities, like individuals, should be dealt with if they disobey regulations for the public good. If the police fail in their duty the remedy lies in dealing with the chief constable of the county, and where the owner or person in charge is responsible for a breach of the law, a full exercise of the penalties provided for the offences should be employed.

In other words, it is the duty of the Board to see that Parliament is obeyed, and the confession of weakness in bemoaning the slackness of the local machinery should never occur. On the other hand, there should be published annually the number of prosecutions throughout the country for breaches of the Act, and the fines thus obtained should be placed to the compensation account. This is our conception of the real duties of the lay officials of the Board. It is not the duty of the veterinary officers to be troubled with questions of why a local authority fails to carry out

what it is ordered to do, and, conversely, it is not the function of laymen to enquire into or write on questions of pathology and animal diseases.

LEGISLATIVE MEASURES AND THE ACT ON WHICH THEY ARE  
BASED.

Epizootic diseases are controlled by the Board of Agriculture, under special powers granted by Act of Parliament in the Diseases of Animals Act, 1894.

The Diseases of Animals Act, 1894, embodied all that it was desirable to retain of the Contagious Diseases (Animals) Acts, 1878 to 1893. It is the machinery by which the entire administration of the diseases of animals in this country is conducted, and has only twice been added to since its introduction; once in 1896, when the law admitting the landing of foreign animals alive was repealed, and for the second time in 1903, in improving the legislative measures for dealing with scabies in sheep.

These three Acts are spoken of as the Diseases of Animals Acts, 1894 to 1903, and the country which is benefiting by the regulations there laid down, and which in their ignorance they have opposed and fought against in the past, little knows how much they are indebted to the veterinary profession which is hidden within the folds of the designation 'Board of Agriculture and Fisheries.'\*

Under the powers conveyed by the Diseases of Animals Acts of 1894-1903, Orders are issued bearing on the following diseases, which at present are all that are included under the working of the above Act, viz. :

Cattle Plague,  
Pleuro-pneumonia,  
Foot and Mouth Disease,  
Sheep-pox,

\* The names of Brown, Cope, and Duguid will, it is hoped, never be forgotten in connection with this work. It is permissible to speak with some freedom on this point, as Mr. Duguid is unfortunately dead, and the other gentlemen mentioned are not now in office.

Sheep Scabies,  
 Swine Fever,  
 Glanders,  
 Rabies,  
 Anthrax,  
 Tubercular Disease of the  
 Udder of Cows,  
 Epizootic Lymphangitis.

In course of time outside pressure, the result of intelligence, will compel other diseases to be scheduled under the Act, and the first of these will doubtless be tuberculosis. Parasitic Mange in Equines (Ireland), is scheduled by the Irish Department, while certain parts of Great Britain are also brought under the operations of an Order.

The Orders on the above diseases are frequently being amended to meet the necessities of the case, for example, in the fight against Foot and Mouth Disease, exclusive of many hundreds of Orders passed prior to 1881, in the three years 1881-1883 no less than 2,411 Orders dealing solely with the disease were passed!

This may be easily understood on reference to Section 22 of the Diseases of Animals Act, 1894, which confers immense powers on the Board of Agriculture under thirty-seven headings, which, as they represent the kernel of the Act, are here reproduced :

#### DISEASE AND MOVEMENT GENERALLY.

*Power for Board of Agriculture to make Orders for Prevention or Checking of Disease, and other Purposes.*

22. The Board of Agriculture may make such orders as they think fit, subject and according to the provisions of this Act, for the following purposes, or any of them :

- (i.) for prescribing and regulating the publication by placards, hand-bills, or otherwise, in the immediate neighbourhood of a place or area declared infected, of the fact of such declaration ;
- (ii.) for prohibiting or regulating the movement of animals and persons into, within, or out of an infected place or area ;
- (iii.) for prescribing and regulating the isolation or separation of animals being in an infected place or area ;

- (iv.) for prohibiting or regulating the removal of carcasses, fodder, litter, utensils, pens, hurdles, dung, or other things into, within, or out of an infected place or area ;
- (v.) for prescribing and regulating the destruction, burial, disposal, or treatment of carcasses, fodder, litter, utensils, pens, hurdles, dung, or other things, being in an infected place or area, or removed thereout ;
- (vi.) for prescribing and regulating the cleansing and disinfection of infected places and areas, or parts thereof ;
- (vii.) for prescribing and regulating the disinfection of the clothes of persons coming in contact with or employed about diseased or suspected animals, or being in an infected place, and the use of precautions against the spreading of disease by such persons ;
- (viii.) for prohibiting or regulating the digging up of carcasses which have been buried ;
- (ix.) for prohibiting or regulating the exposure of diseased or suspected animals in markets or fairs or sale-yards, or other public or private places, where animals are commonly exposed for sale, and the placing thereof in lairs or other places adjacent to or connected with markets or fairs, or where animals are commonly placed before exposure for sale ;
- (x.) for prohibiting or regulating the sending or carrying of diseased or suspected animals, or of dung or other thing likely to spread disease, or the causing the same to be sent or carried, on railways, canals, rivers, or inland navigations, or in coasting vessels, or otherwise ;
- (xi.) for prohibiting or regulating the carrying, leading, or driving of diseased or suspected animals, or the causing them to be carried, led, or driven on highways or thoroughfares, or elsewhere ;
- (xii.) for prohibiting or regulating the placing or keeping of diseased or suspected animals on commons or uninclosed lands, or in fields or other places insufficiently fenced, or on the sides of highways ;
- (xiii.) for prescribing and regulating the seizure, detention, and disposal of a diseased or suspected animal exposed, carried, kept, or otherwise dealt with in contravention of an order of the Board ; and for prescribing and regulating the liability of the owner or consignor or consignee of such animal to the expenses connected with the seizure, detention, and disposal thereof ;
- (xiii*a*.) for prescribing, regulating, and securing the periodical treatment of all sheep by effective dipping, or by the use of some other remedy for sheep scab.

- (xiv.) for prescribing the mode of ascertainment of the value of an animal slaughtered, or liable to be slaughtered, by order of the Board or of a local authority ;
- (xv.) for regulating applications for, and the mode of payment of, compensation to be paid out of money provided by Parliament ;
- (xvi.) for prescribing and regulating the destruction, burial, disposal, or treatment of carcases of animals slaughtered by order of the Board or of a local authority, or dying while diseased or suspected ;
- (xvii.) for prohibiting or regulating the movement of animals, and the removal of carcases, fodder, litter, dung, and other things, and for prescribing and regulating the isolation of animals newly purchased ;
- (xviii.) for prescribing and regulating the issue and production of licences respecting movement and removal of animals and things ;
- (xix.) for prohibiting or regulating the holding of markets, fairs, exhibitions, and sales of animals ;
- (xx.) for prescribing and regulating the cleansing and disinfection of places used for the holding of markets, fairs, exhibitions, or sales of animals, or for lairage of animals, and yards, sheds, stables, and other places used for animals ;
- (xxi.) for prescribing and regulating the cleansing and disinfection of vessels, vehicles, and pens and other places, used for the carrying of animals for hire or purposes connected therewith ;
- (xxii.) for prescribing modes of cleansing and disinfection ;
- (xxiii.) for prohibiting the conveyance of animals by any specified vessel to or from any port in the United Kingdom for such time as the Board may consider expedient ;
- (xxiv.) for insuring for animals carried by sea a proper supply of food and water and proper ventilation during the passage and on landing ;
- (xxv.) for protecting them from unnecessary suffering during the passage and on landing ;
- (xxvi.) for protecting animals from unnecessary suffering during inland transit ;
- (xxvii.) for securing a proper supply of water and food to animals during any detention thereof ;
- (xxviii.) for prescribing and regulating the marking of animals ;
- (xxix.) for prohibiting, absolutely or conditionally, the use, for the carrying of animals or for any purpose connected therewith, of a vessel, vehicle, or pen or other place in respect whereof, or of the use whereof, a penalty has been recovered from any person for an offence against this Act ;

- (xxx.) for prescribing and regulating the muzzling of dogs, and the keeping of dogs under control ;
- (xxxi.) for prescribing and regulating the seizure, detention, and disposal (including slaughter) of stray dogs and of dogs not muzzled, and of dogs not being kept under control, and the recovery from the owners of dogs of the expenses incurred in respect of their detention ;
- (xxxii.) for prescribing and regulating the payment and recovery of expenses in respect of animals ;
- (xxxiii.) for prescribing and regulating the form and mode of service or delivery of notices and other instruments ;
- (xxxiv.) for authorising a local authority to make regulations for any of the purposes of this Act or of an order of the Board subject to such conditions, if any, as the Board, for the purpose of securing uniformity and the due execution of the provisions of this Act, think fit to prescribe ;
- (xxxv.) for extending, for all or any of the purposes of this Act, the definition of disease in this Act, so that the same shall for those purposes, or any of them, comprise any disease of animals in addition to the diseases mentioned in this Act ;
- (xxxvi.) for extending, for all or any of the purposes of this Act, the definition of animals in this Act, so that the same shall for those purposes or any of them comprise any kind of four-footed beasts, in addition to the animals mentioned in this Act ; and
- (xxxvii.) generally, for the better execution of this Act, or for the purpose of in any manner preventing the spreading of disease.

In addition to these there are thirteen headings under Section 30 on which Orders may be made for the Regulation of Ports. We reproduce this section, and particularly refer to the immense, almost arbitrary, powers conferred on the Board (and rightly so), especially in paragraph 13.

*Regulation of Ports.*

**30.**—(1) The Board of Agriculture may make such orders as they think fit, subject and according to the provisions of this Act, for the following purposes, or any of them :—

- (i.) for prescribing the ports at which alone foreign animals may be landed ;
- (ii.) for defining the limits of ports for the purposes of this Act ;

- (iii.) for defining parts of ports ;
- (iv.) for prohibiting or regulating the movement of animals into, within, or out of a defined part of a port ;
- (v.) for prescribing and regulating the inspection and examination, and the mode, time, and conditions of slaughter, of animals in a defined part of a port ;
- (vi.) for prescribing and regulating the disposal of animals, not being foreign animals, and being in a defined part of a port ;
- (vii.) for regulating the removal of carcasses, fodder, litter, utensils, dung, or other things, into, within, or out of a defined part of a port, and the disposal thereof, when likely to introduce or spread disease ;
- (viii.) for prescribing and regulating the cleansing and disinfection of a defined part of a port or of parts thereof ;
- (ix.) for prescribing and regulating the disinfection or destruction of things being in a defined part of a port or removed thereout ;
- (x.) for regulating the movement of persons into, within, or out of a defined part of a port ;
- (xi.) for prescribing and regulating the disinfection of the clothes of persons employed or being in a defined part of a port, and the use of precautions against the introduction or spreading by them of disease ;
- (xii.) for prescribing and regulating the seizure and detention of any foreign animal, carcase, fodder, litter, dung, or other thing whereby disease may be introduced or spread ; and
- (xiii.) generally, for the better execution of this Act in relation to foreign animals, carcasses, fodder, litter, dung, or other things, or for the purpose of in any manner preventing the introduction or spreading thereby of disease.

The Diseases of Animals Act confers powers on two authorities :

1. The Board of Agriculture or Central Authority.
2. The Local Authorities acting under the Central Authority.

It by no means follows that the Local Authority has the same power as the Central ; there are many things they cannot do, and they may even pass regulations which the Central Authority may rescind ; but as the people on the spot they are supposed to be directly interested in anything intended for the welfare of the area under their control,

and further, are the authorities of the area from a legal point of view.

The Diseases of Animals Act, 1894, defines the Local Authorities of England and Wales as the Borough Council and County Council, while for the City of London, and the carrying out of the Act relating to the importation of foreign animals into the county of London, the Local Authority is the Common Council of the City of London.

The Local Authority for Scotland in certain burghs is the Magistrate and Town Council, while for each county and any burgh not included in the above, the County Council is the recognised authority.

The Local Authorities for Ireland are the Board of Guardians of the several Poor Law Unions.

The Diseases of Animals Act, 1894, requires that every person having in his possession or under his charge an animal affected with any of the diseases scheduled under the Act, shall isolate the same, and at once report the existence of the disease to the police of the area. The obligation of notification is imposed on the owner, and not on the professional attendant. Moreover, the law regards the owner or person in charge of the animal as knowing of the existence of disease or illness, and the proof of not knowing, or inability, after the exercise of reasonable diligence, to have obtained that knowledge, lies on the shoulders of the owner or person in charge.

It is the duty of the police of each area to enforce and execute the Act, and the powers given them are considerable. A person may be apprehended without a warrant, even if only reasonably suspected of committing an offence against the Act.

Each Local Authority in England and Wales is compelled to keep at least one veterinary inspector, or as many more as the Board of Agriculture directs. An inspector is not a veterinary inspector, but a layman employed to do the duty of a professional man. An inspector possesses the same powers as a constable has under the Act. He may enter any land, or building, place, vessel, or boat when he



has reasonable grounds for believing either that disease exists, or that the Act is being contravened. In a court of justice his certificate is conclusive evidence of the matter certified.

In Ireland the Local Authorities are not compelled to keep a veterinary inspector. These duties may be vested in an inspector, who, if qualified, may be styled a veterinary inspector.\*

Local authorities are provided under the Act with considerable powers, but, from a legislative point of view, none are so important as those given in Section 39, by which two local authorities, for the better control of disease within their border, may agree to form a united district and place the whole under one uniform system of control. This is a most enlightened enactment, with far-reaching possibilities, if only local authorities would work harmoniously. It is the best evidence we possess that legislation recognises that disease is no respecter of parish or county boundaries, and that combined action in a united district is more likely to be attended by good results than operations within a limited sphere.

The definition of infected places, areas, and circles of disease generally, are laid down in Sections 8 and 9 of the Act, which deals more especially with pleuro-pneumonia and foot and mouth disease; while Sections 10 and 12 are general provisions as to infected places, areas, and circles.

An infected circle may be declared by order of the Board instead of an infected area. Such a circle comprises the whole space lying within a distance of half a mile from any part of the infected place. The Board has power, however, to control the limits of an infected circle.

Movements into, out of, and within an infected area or

\* Ireland does not avail herself of the specially sanctioned unqualified inspector, nor resort to lay assistance so common in Great Britain. In this she shows her wisdom, and offers a good object-lesson to her neighbour.

circle can only be made by the authority of the Board, which can also cancel the holding of any fair, market, or sale of animals within an infected area.

Where two or more circles infected with the same disease overlap each other, the whole may be declared one infected circle.

All persons, excepting those authorized by law, may be forbidden to enter any building where diseased animals are kept, and of which the place has been declared infected. The owner's notice to this effect affixed to the entrance of the building or enclosure is effective in law, but the local authorities can also earmark the place.

There are several sections in the Act we have not touched on—viz., Compensation for Slaughter; Foreign Animals; Local Authorities, their General Provisions and Expenses; Offences and Legal Proceedings; Special Provisions referring to Scotland and Ireland; also a great many regulations dealing with Cattle Plague, Pleuropneumonia, Foot and Mouth Disease, and Swine Fever.

Some of these, and the various Orders of the Board under the Act bearing on disease, will be noticed in connection with each malady.

The Acts and Orders are drawn up by the law officers of the Crown, but no amount of careful reading of an Order can take the place of common-sense. This is evident in the narrow interpretation by local authorities and lay inspectors as to what constitutes an 'in-contact,' the layman's idea being that the animals must actually touch each other! Nothing but skilled advice backed by experience can here be of any value. Pigs, for example, diseased and healthy, might conceivably be only a foot apart and the healthy run no risk, or they might be twenty or thirty yards apart and the healthy run every chance of infection. An example of the first would be two styes in different yards with a brick wall separating them, and of the second two styes in the same yard, the excreta from that containing diseased swine being washed into the other by rain, or carried on the boots and clothes of attendants.

The definition of an in-contact should be as comprehensive as possible.

1. Every animal living under the same roof, or being on the same farm or place.

2. All animals looked after by the same attendants, or receiving the same food or water-supply.

3. All animals which have passed through or over roads previously travelled by diseased animals.

The definition of in-contacts should not be confined to only those animals actually in contact with the diseased. Mysterious outbreaks of foot and mouth disease are due no doubt to the agency of an intermediate carrier. Dogs may convey the disease, also the boots and clothing of attendants, or the walking-stick of the visitor; rats, it is suggested, may convey swine fever, while human agency and probably dogs are a fruitful cause. Though it is not proposed here to carry the definition of in-contacts to these, yet in the strict sense of the term they come within the meaning, and such measures as are possible should be exercised to prevent these causes of spread being in operation.

The nature of the virus must also influence our definition of an in-contact and the measures adopted. The horse that reacts to mallein but shows no clinical sign of disease is not a source of infection, and the limit of in-contact can well be confined to the horse he works with, or those standing on either side of him in the stable.

The cow with pulmonary tuberculosis may not only directly infect her neighbours by the expectorate, but the latter when dried may infect animals by inhalation which are distant from the centre.

The animal with anthrax is only dangerous when the blood is shed; none of those under the same roof run any real risk of infection from the diseased patient.

The cow with pleuro-pneumonia infects the air of the place she lives in, and is only harmless when dead.

The evacuations in Cattle Plague contain the virus as does also the blood; pastures and water-supply may in this way be poisoned over a considerable area.

Animals with foot and mouth disease may infect the whole of the road they are driven over, and the pastures they have been on; the virus may be carried from one end of the county to the other by even non-ruminant animals, by fodder, and other inanimate bodies.

Swine fever is spread broadcast by the evacuations of the disease, through human agency, dogs, and food and water soiled by the excreta of the affected.

These points are only mentioned as bearing on the definition of in-contact, and showing how wide it may be in some diseases, and how restricted the term may be in others.

*Markets and Fairs.*—In connection with this may be considered the holding of fairs and markets, which, it is obvious, excepting under the most rigid precautionary measures, may be centres for distributing disease.

Taking once more swine fever, no reasonable person can doubt the influence of markets in spreading the disease broadcast, bearing in mind that pigs may be affected and show little if any sign of ill-health, or only such signs of the affection in a chronic form, that there is nothing sufficiently diagnostic to certify to.

There is nothing to prevent these swine finding their way into a market, and infecting every place they are taken to; and, in addition, the farmer, pig dealer, and others, leave the market for their homes with all the needful virus on their boots, clothes, and hands, for starting fresh centres or renewed outbreaks.

Here again the Central Authority should come in, and only under the most rigid conditions should pig markets be sanctioned if the disease is to be stamped out. The same reasoning applies to many other diseases.

#### CATTLE PLAGUE.

It is unnecessary to refer again to the history of this disease in Great Britain. The first outbreak caused the death of 400,000 cattle, and took nearly two years to exterminate as no veterinary machinery existed. The second

outbreak in 1872 was got rid of in a few months, while the third outbreak was promptly stamped out.

The home of the disease is Asia, it is never absent from India, and though Europe at the present moment is free, there is no guarantee that it can never again become infected.

The disease is one essentially affecting cattle, though sheep, goats, deer, antelope, yak, and camels suffer. It is a highly infectious fever, possessing a fairly definite period of incubation, which is generally between the third and fourth day after infection.

The blood and excretions of the affected animals are extremely virulent, and by means of the latter the disease among animals at pasture is rapidly spread and water-supply infected. This is especially the case owing to the diarrhoea which is almost invariably present at some stage of the disorder.

Other means of infection are through human agency, the excretions being carried about on the boots and clothes of those who have been in contact with the affected cattle; also by flesh, hides, hoofs, horns, etc.

The infective material does not appear to be carried very far by the atmosphere; further, it is readily killed by drying and by putrefaction.

The reason of the rapidity and certainty with which the disease spreads depends, then, upon its extreme infectivity.

Like every other epizootic disease, the diagnosis is very simple when one is certain of the existence of plague; it is the earlier cases which create doubt. Even a post-mortem examination, though revealing definite lesions, cannot point to any particular one as being present solely in cattle plague. The chief post-mortem sign looked for is the ulceration of the fourth stomach and bowels; but apart from this, where Rinderpest exists, it is not very long before overwhelming evidence of its presence is available. The symptoms to which the utmost importance should be attached are the red colour and probably small ulcerations of the mucous membrane of the mouth, the discharge of

saliva and tears; catarrh with redness of all visible mucous membranes, diarrhoea, peculiar foetid odour of the breath, great prostration, and high body temperature.

It is at about the sixth day of the infection that the symptoms are best observed.

The methods to be adopted to get rid of Rinderpest depend upon the country; in the small and congested British Islands the question of treatment cannot be entertained, the destruction of all infected and all in-contacts is imperative. In this respect the term in-contacts must be liberally interpreted. In the case of a farm it means the destruction of every ruminant in the place, with complete isolation of the other animals of the farm for a period of at least two months.

The most ruthless destruction is in the end an economical proceeding, but for staying the extension of disease it will not prove effective unless every living animal, man included, is kept isolated and within a cordon which must at once be drawn as far as possible around the infected area.

Whatever passes into that farm by accident, be it tradesman, or dog, must remain there; the man until thoroughly disinfected, the dog until the outbreak is over. The place is to be as isolated as if it lay in the middle of the Atlantic Ocean.

Those whose duty it is to watch the cordon, should be provided with means of destroying all small animals which may be wandering about, even birds should be destroyed.

One of the most important lessons to be learned from experience in dealing with epizootic diseases is the weakness of even the strictest sanitary cordon; neither fences nor bayonets can be depended upon to keep out disease, for the number of leakages in the best established system are manifold.

In South Africa, Cape Colony spent thousands of pounds in erecting a wire fence along its immense frontier to keep out Cattle Plague from the north, and guarded every inlet, still the disease found its way in, for the possible leakages

in a line hundreds of miles long were necessarily numerous.

The next important step is to establish a second cordon some distance outside the first, and all cattle within this should be immunised in the first instance by bile inoculation, or by serum and virulent blood. These materials will be dealt with presently, the point at present to insist on is an inoculated area around the zone of infection, and movements of animals either in or out of this area should be rendered impossible.

As we must suppose the disease does not exist in the outer zone, the system of isolation of the occupants of the farms need not be carried out, though no movements of cattle of any kind should be permitted.

The guiding principles of preventing the spread of this and allied diseases are : (1) The destruction of all affected and susceptible animals in the affected place, and the complete isolation of all human beings and other animals ; (2) the establishment of an outer zone, the security of which it is endeavoured to obtain by inoculation, and the stoppage of all animal movements. In this way a protected area surrounds the affected place.

It is impossible to believe that if this disease again found its way into England only one centre of affection could occur. The probability is that there would be several, but the principles are the same in each as stated above.

While all this is being carried out, the affected place is being disinfected. For the details of this process the chapter on 'Disinfection' should be referred to.

It is important to bear in mind that the entire destruction of all manure should be carried out ; it is not possible to differentiate between that from diseased and that from healthy animals. Every particle must be destroyed by fire, with the aid of paraffin if necessary, and any deposited on the land must be collected and destroyed.

If the affected area be considered as comprising the inner and outer zones, the affected district is the one in which the area is situated.

In the affected district all cattle movements, both in and out, must be suspended, all fairs, markets, etc., withheld. The movements within the area must be confined entirely to horses by special movement license, and even that, so far as it is possible, should be restricted to high roads, avoiding farms, commonage, and pastures. The sole object of this is to prevent these animals being a possible means of distributing infected dung through the medium of their feet.

In a word, the infected district must be regarded as a town in a state of siege, with all its inconveniences and none of its risks.

This means an amount of self-sacrifice that many people dislike to make, but it is necessary, and the results of such a rigid system as has been described above, would be to localize the plague to affected places only.

In a country like the United Kingdom it is too much to hope that a single case of the disease would occur; a few finding their way in would infect all those places they have passed over between the port of debarkation and the farm on which they were eventually attacked. The railway company should therefore direct their attention to the thorough disinfection of all rolling stock used for cattle, which had recently been into the infected district. It might even be possible to trace the affected truck, by knowing the date of arrival of the affected animals at their destination.

If the animals were driven over any highway it is obvious this is a possible source of infection, but by stopping the movements of all cattle in the affected district the risk from this is greatly reduced.

No stone should be left unturned to stop every source of leak; it is neglect of the small, and, to the outside observer, apparently unimportant points which may defeat the best conceived measures of eradication. In South Africa the disease was spread by allowing the natives to utilize the flesh of the destroyed animals. Foot and mouth disease was repeatedly introduced into this country from



non-infected countries, owing to the cattle-men taking back to America with them head-ropes which had got infected in Deptford Market from European cattle, and so infecting on the high seas the previously healthy stock from another Continent.

This example is given on the authority of the Chief Veterinary Officer of the Board of Agriculture,\* and is quoted as an excellent object-lesson of the point we are now insisting upon, that the best preventive measures may be defeated by want of attention to detail, and the failure to close up every possible leak.

In dealing with Cattle Plague in any of the British possessions the same principles are adopted, though the precise details may differ. A very much larger area of the country may be declared infected, but this extra safeguard is neutralized by the fact that it may be less possible or more difficult to form an inner and outer zone of infection. Further, the destruction of all affected and in-contacts may not be possible owing to local conditions, and, again, the early destruction of the affected may not be desirable, as from them material is required for the protective inoculation of the apparently healthy.

*Group System.*—In these cases, therefore, the group system is adopted. The animals are classed according to whether apparently healthy, suspicious, or affected; they are drafted from one group to the other as cases manifest themselves, and as far as possible at once dealt with by protective inoculation.

The farm on which the cases have occurred should be rigidly isolated, no one allowed to leave it, and all surrounding farms must be dealt with by inoculation, so as to place a protected zone around the area of infection; all movements of cattle in this protected zone must cease.

The attendants on the sick should be confined to these duties and no other; hands, feet, boots, clothes, must be daily subjected to the process of disinfection, for which

\* Annual Report of Chief Veterinary Officer, Board of Agriculture, 1901.

purpose a large bath of disinfectant should be available. The veterinary attendant must be no less particular, a change of boots and clothes is essential, besides thorough disinfection of the hands, otherwise he will carry the disease from farm to farm.

*Methods of Inoculation.*—The protective inoculation employed against rinderpest consists of bile or serum inoculations, and these must be separately considered.

*Bile inoculation.* The gall-bladder of an ox dead of the disease is frequently distended with bile, varying in tint from a deep green to red, and sometimes being thick and curdy-looking. In selecting bile for inoculation, that which is green in colour is preferred, and if on shaking a froth is produced, it is an additional indication of its suitability. The only biles which should positively be rejected are the red ones, as the colour of these is due to blood.

The bile inoculation will not save animals which are already affected from getting the disease, but it will protect all those with a normal temperature. Where bile is scarce, and it frequently is, this point of not wasting it on animals already possessing a temperature should be borne in mind.

The bile contains the immunising substance, but in varying amounts; further, it also contains the virus of the disease. To overcome the varying amount of the immunising substance, all the biles are mixed together, so that the deficiency in one is made up by an excess in another; the difficulty arising from the presence of the virus in the bile is got rid of by keeping it for at least two days before use, if possible mixed with glycerine as a preservative, in the proportion of one part of glycerine to two of bile. The dose of this mixture is 30 c.c.; it is found from experience that at least 10 c.c. of bile are required to give immunity.

Where it is desired to get a very rapid immunity the mixture of glycerine and bile may be injected into the jugular vein. Immunity begins to appear about six days after inoculation, and is complete about the tenth day.

There are drawbacks to the bile methods, one being the difficulty of getting it in sufficient quantity, and the other

that the immunity produced is but temporary, lasting only a few months; but these few months may be quite sufficient to enable the disease to be eradicated.

The immunising substance does not exist in bile taken from animals recently attacked, it is always present when taken from those at the point of death.

The other method of protection is by the use of serum from animals which have been artificially immunised, and fortified to such an extent that instead of a single drop of blood producing the disease, they are capable of standing nearly eight quarts of virulent material being introduced into their system without manifesting any disorder. But the process of hyper-immunisation is a long and tedious one, and has to be gradually brought about. Once the serum is obtained and its strength known, viz., how much of the serum will neutralize a given amount of virulent blood, the inoculation may proceed.

The principle in serum inoculation is that with the serum is administered a dose of virulent blood, both being simultaneously injected. The serum must be strong and reliable, 30 c.c. of strong serum and 1 to 2 c.c. of virulent blood confer a lasting immunity.

It must be borne in mind that the use of virulent blood is not without risk of conveying other affections, hence in South Africa it was found that though immunity against Cattle Plague was obtained, yet Texas Fever (red water or hæmoglobinuria) was readily conveyed, likewise other diseases, such as anthrax and quarter-evil. Where these diseases do not exist in a country, or only to a limited extent, the risk is correspondingly reduced.

Serum may also be used as a curative agent for Cattle Plague, but a consideration of this matter is outside the scope of this work.

#### LEGISLATION.

*The Diseases of Animals Act, 1894, and the Cattle Plague Order of 1895.*

*Notice of Disease.*—This is to be given to a constable of the police area with all practicable speed by the person having, or having had, in

his possession or under his charge an animal affected with or suspected of Cattle Plague. The duty of the police is to report to the Board of Agriculture by telegraph and to the Local Inspector, who reports it to the local authorities.

*Duties of Inspector.*—It is the duty of the Inspector to act immediately; he serves a notice on the occupier of the cowshed, field, or place, notifying the existence of Cattle Plague, and if necessary on the occupiers of all lands and buildings within one mile in any direction of the affected place. All such places notified are included in the infected area, the exact extent of which is subsequently confirmed by the Board.\*

*Movements of Animals.*—No movement of *any animal*† is permitted out of a place where Cattle Plague exists or is supposed to exist; nor may fodder, litter, manure, utensils, etc., be removed.

\* The duties of Inspectors are frequently referred to in this chapter, so that the section of the Act under which they obtain their powers is here reproduced.

The *General Powers of Inspectors* are defined in Section 44 of the Diseases of Animals Act, 1894.

‘1. An Inspector shall have for the purpose of this Act all the powers which a constable has, under this Act or otherwise, in the place where the Inspector is acting.

‘2. An Inspector may at any time enter any land or shed to which this Act applies, or other building or place wherein he has reasonable ground of supposing—

‘(a) that disease exists or has within fifty-six days existed; or

‘(b) that the carcass of a diseased or suspected animal is or has been kept, or has been buried, destroyed, or otherwise disposed of; or

‘(c) that there is to be found any pen, place, vehicle, or thing in respect whereof any person has on any occasion failed to comply with the provisions of this Act, or of an order of the Board of Agriculture, or of a regulation of a local authority; or

‘(d) that this Act or any order of the Board or a regulation of a local authority has not been or is not being complied with.

‘3. An Inspector may at any time enter any pen, vehicle, vessel, or boat in which or in respect whereof he has reasonable grounds for supposing that this Act or an order of the Board or a regulation of a local authority has not been or is not being complied with.

‘4. An Inspector entering, as hereinbefore by this section authorized, shall, if required by the owner, or occupier, or person in charge of the land, building, place, pen, vehicle, vessel, or boat, state in writing his reasons for entering.’

† The term ‘animal’ here means horse, ass, mule, dog, all ruminating animals, and swine.

It is the duty of the local authorities to enforce these conditions on the declaration of their Inspector, and constables shall be posted for the purpose.

No person excepting the one tending the animals is permitted to enter the place where the diseased or suspected animals exist, and both Inspector and attendant before leaving shall disinfect their clothing, hands, and boots.

Very stringent regulations are laid down regarding the removal of manure, litter, fodder, pens, hurdles, carcasses, or anything which has been in an infected place. Equally stringent are the regulations regarding the movements of animals in the affected place; none whether affected or not can be moved out, none can be moved in, and no animal can be brought in contact with any to which the notice applies.

*Destruction of Affected.*—The Board have power to destroy all animals\* affected with Cattle Plague, and all in-contacts. Any suspect may be destroyed, and under special authority, any animal within a declared area though not actually in the infected place.

*Compensation.*—Compensation on this account is given out of special Parliamentary funds, one half value being paid for affected cases provided that twenty pounds is regarded as the limit; in all other cases full value, but not exceeding forty pounds.

Special regulations are laid down for ascertaining the value for compensation in England, Wales, and Scotland.

*Disposal of Carcasses.*—The local authority shall cause the carcase to be buried in its skin previously slashed, not less than six feet below the surface, and covered with a sufficient quantity of quicklime or other disinfectant; or the carcase may under special licence, and after disinfection, be conveyed under the charge of an officer of the Local Authority to an approved place, and there destroyed by chemicals or incineration.

This regulation to apply only to those animals which have *died*, or suspected to have died, of Cattle Plague. When animals are *destroyed* by the Board under the Act of 1894, the carcase belongs to the Board, and is to be buried, sold, or otherwise disposed of by them, as the condition of the animal, carcase or other circumstances shall require or admit.

When an animal has been destroyed by the Board under the Act of 1894, the carcase may be buried in any ground in the possession or occupation of the owner of the animal, if suitable for the purpose; common land may also be used for the burial, if approved by the Board.

---

\* 'Animals' is defined as all ruminating animals and swine.

It is an offence to dig up the carcase of any animal that has been buried.

*Disinfection.*—Every facility has to be given by the owner or occupier for the disinfection of an affected place, and it is an offence to fail in this matter. The nature of the disinfection is not defined.

*Seizure of Animals.*—The Inspector of a local authority may cause to be seized all animals affected with Cattle Plague exposed for sale anywhere, or in course of being moved by land or water, or on common land, or anywhere not in the occupation or under the control of the owner of the animal.

The seizure of the affected must also comprise the seizure of all animals present at the same time in the place ; the declaration of the place as an infected place can only be made by the Board and not by the local authorities, but such place cannot be used again for animals until it has been cleansed, disinfected, and the Veterinary Inspector's certificate obtained.

A slaughter-house in which an animal affected with Cattle Plague has been found shall not be declared an infected place excepting by the Board.

There are certain regulations regarding the exposure and movement of diseased or suspected animals which are produced in full, as they apply to several other epizootic affections, and will be frequently referred to in the following pages :

*Section XII. Cattle Plague Order of 1895 : Prohibition to expose or move Diseased or Suspected Animals.*—It shall not be lawful for any person—

(a) to expose a diseased or suspected animal in a market or fair, or in a sale-yard, or other public or private place where animals are commonly exposed for sale ; or

(b) to place a diseased or a suspected animal in a lair or other place adjacent to or connected with a market or a fair, or where animals are commonly placed before exposure for sale ; or

(c) to send or carry or cause to be sent or carried, a diseased or suspected animal on a railway, canal, river, or inland navigation, or in a coasting vessel ; or

(d) to carry, lead, or drive, or cause to be carried, led or driven, a diseased or suspected animal on a highway or thoroughfare ; or

(e) to place or keep a diseased or suspected animal on common or uninclosed land, or in a field or place insufficiently fenced, or in a field adjoining a highway unless that field is so fenced or situated that animals therein cannot in any manner come in contact with animals passing along that highway or grazing on the sides thereof ; or

(f) to graze a diseased or suspected animal on pasture being on the sides of a highway ; or

(g) to allow a diseased or suspected animal to stray on a highway or thoroughfare or on the sides thereof or on common or uninclosed land, or in a field or place insufficiently fenced.

*Offences.\**—It is an offence to move any animal in contravention of the order or notice served under it. The owner of the animal, the person for the time being in charge, the person moving or conveying the animal, the person receiving or keeping it, knowing it to have been removed in contravention, and the occupier of the place from which the animal has been moved, are each guilty of an offence against the Act.

If in contravention of any regulation of the local authority a carcass be removed, or not buried, or not destroyed, it constitutes an offence.

If a person in charge of any animal, carcass, or thing being moved under the movement license of the local authority gives a false name or address it constitutes an offence.

If a person to evade the operation of the Order allows any animal to stray he is guilty of an offence.

#### PLEURO-PNEUMONIA.

This disease, like many others which have decimated the herds and flocks of the United Kingdom, was introduced from abroad. In 1839 it found its way into Ireland, and in 1841 into England, and for years was allowed to go unchecked by any legislation. One explanation of this is due to the fact that its contagiousness was denied, but it is difficult to believe that this opinion was generally held, excepting by laymen. In 1867 pleuro-pneumonia is first mentioned in an Act of Parliament, but it was not until 1869 that it was scheduled as a disease; since then successive Acts have been directed against this affection, each stronger than the last, until it has been finally surrounded and obliterated.

The history of this disease is an admirable object-lesson of entrusting statutory powers to the 'local authority.' While pleuro-pneumonia was dealt with by these no appreciable effect was produced upon the disease; it was not until the Act of 1890 transferred the power of local authorities to the Central Authority, viz., the Board of Agriculture, that the disease was exterminated. Yet this costly experiment

\* The original Order should be consulted.

did not teach our legislators a lesson; the blunder has been committed with swine fever with equally disastrous results.

The State does not destroy a man's property without compensating him, and, though we hold very radical views on the question of compensation generally, this is a sound and wise proceeding; but it is unsound to throw the cost of compensation on the local rates, the charge should be an Imperial one. It is hoped that the next object-lesson which will be taken to heart, is that compensation being for the public good should come out of the Imperial Exchequer, and not out of the local rates, or those local authorities on whom the cost of compensation falls are sure to endeavour in every possible way to evade their obligations, in order that they may keep the rates down and stand well in the eyes of the electorate.

Pleuro-pneumonia was a disease in which compensation from the local rates was authorised by the Act of 1878, three-quarter value (not exceeding £30) being paid for the diseased, and full value (not exceeding £40) being paid for in-contacts. The remuneration for ordinary stock was liberal, but for pedigree stock disastrous. By the Act of 1890 compensation no longer fell on the local rates, and the disease became a thing of the past, no case having been reported in the United Kingdom since 1898.

The method of dealing with pleuro-pneumonia in the United Kingdom is by destruction of all affected and in-contacts, and the isolation of the infected area, in which all movements into and out of are stopped.

This disease, though highly infectious during the life of the animal, cannot possibly be conveyed either by blood, hides, carcasses, fodder, fæces, or by persons in contact with the sick. So far as we know it can only be conveyed from one animal to another by the expired air from the lungs.

It is a disease, therefore, where the stoppage of all movements within the affected area is unnecessary, it is sufficient to quarantine the affected places, and to destroy the whole herd, to insure complete eradication.

In dealing with the disease in less congested countries



than the United Kingdom, other measures may be adopted, less radical, perhaps less perfect, but more suited to the local conditions. These measures are destruction of the affected and inoculation of all in-contacts.

Destruction of the affected is imperative, as there is abundant evidence to show that animals which apparently recover from the disease are fruitful sources of further infection, even when only quite small areas of lung are involved. On no account should the affected be spared, and a most careful examination of the chests of those it is proposed to keep is imperative; this taken into consideration with the temperature may prevent sources of infection being retained.\*

Any animal indicating pneumonia must be included in those for destruction, only those are retained for inoculation which have a clear chest, normal temperature, and look well.

*Protective Inoculation.*—The beneficial effects of inoculation have been denied, and as a means of stamping out the disease in a country like the United Kingdom it cannot for a moment be entertained. Communications are too extensive, the country too small, and sources of leakage too numerous, to trust to any system but that of ruthless obliteration. In our other possessions, especially those occupied by an alien race, the destruction of diseased animals is not understood, and is resented; it has even been known to provoke a native rising, and in such cases our obvious policy should be something less effectual, but also less drastic, and fortunately the vast areas and the slow communications are in this respect of help.

Under these circumstances inoculation for pleuro-pneu-

\* We have seen no reason to regret the rule we made in this respect some time ago. The animal we are doubtful of must be secured, and the chest thoroughly overhauled with the phonendoscope. There is no other instrument which for the safety and facility of the examiner (who may have to deal with half wild cattle), and the accuracy of the results which it affords, can approach the phonendoscope, while its long flexible tubes and disc enable every portion of the chest to be explored with ease and certainty.

monia must be practised, and though there are some who deny its value, and it is quite true that those countries which have practised inoculation have not got rid of the disease; yet there is always one strong argument in its favour, viz., that no system of inoculation can reproduce the disease, and the same cannot be said for all methods of protective inoculation, notably rinderpest, anthrax, and black quarter.

Inoculation without the destruction of the affected, fails to eradicate the disease, for the reason that some of the animals which appear to have recovered from a spontaneous attack are sources of infection for long after. It is true they have got some degree of immunity, but they are nevertheless spreaders of disease.

The protective serum of pleuro-pneumonia is furnished in abundance by a case of the disease. The pleuritic effusion, collected while transparent and sweet, may be employed, mixed with glycerine as a preservative. Or the serum may be collected from the lung tissue, though in our experience this is a slow and not altogether satisfactory proceeding, and even with the greatest care blood gets mixed with it.

Another way of obtaining serum is by the subcutaneous inoculation of a calf, which produces a great swelling, and from which the serum may be collected.

The serum collected from the animal maintains its virulence about twenty-five days, but if a protective material be prepared from a pure cultivation of the microbe, the virulence lasts for a considerable time.

The method of inoculation is simple, the end of the tail being selected and threads previously dipped in the virus are introduced subcutaneously for about one inch and left there for a few days; or the material may be injected with a hypodermic syringe, the dose being half a cubic centimetre.

The only untoward results of the operation are swelling of the tail at its root, with great pelvic œdema, but such cases ought to be recognised before the disease extends to the

root of the tail, and dealt with by immediate amputation above the seat of inoculation. All this belongs to the realm of pathology. The point is mentioned here as the question is one of importance to the hygienist. Inoculated animals after about the fourth or fifth day should be inspected morning and evening, and the least sign of carrying the tail away from the body indicates all is not going right, and demands immediate attention.

The greater the local reaction, within reasonable limits, the greater the amount of protection; where there is no reaction in a susceptible animal there is no immunity. A local reaction the size of a hen's egg is sufficient.

There are some who consider one inoculation gives permanent immunity, but it is not so. Theiler places the duration of immunity at probably one year; it does not begin until towards the end of the reaction, and animals exposed to infection before this time contract the disease in spite of inoculation. Inoculation shortens the incubation period.

Inoculation has this value, that by its means we can check the disease, and the losses from the operation are very small provided ordinary care be adopted.

Pleuro-pneumonia is a very insidious affection; it has a long incubative period, probably not less than three weeks or a month, and it would be wise not to declare a herd free until two months after the last case. Again, we must impress the danger of old, so-called encysted, lung cases; these are capable of infecting fresh and unprotected cattle, and in the days when cows were allowed to be treated in the United Kingdom, these encysted cases were, perhaps, the most common means of keeping the disease alive.

#### LEGISLATION.

*The Diseases of Animals Act, 1894, and the Pleuro-Pneumonia Order of 1895.*

The regulations regarding notification, the action of the police, of the Inspector, movements of cattle into or out of an infected place, removal of manure and other things, are practically the same as in Cattle Plague.

The modifications particularly applying to pleuro-pneumonia are that an Inspector can serve a notice on the occupier of an infected place if he believes a case of pleuro-pneumonia to have occurred even fifty-six days previously. Further, the main preventive measures fall to the local authorities rather than the Board, and the former, in declaring the limits of an infected place, may include the adjoining part of the district of another Authority, provided their consent in writing is obtained.

The local authorities may, fifty-six days after the last case of pleuro-pneumonia, declare on veterinary advice the place to be free from disease.

All action and recommendation of the local authorities must be reported to the Board, and the latter have the power to make their own regulations to meet the necessities of the case, and to prohibit or sanction under special conditions the holding of fairs, markets, exhibitions, or sale of animals, within the affected area.

Under certain conditions movements of cattle may be made in an infected *area* by licence of the local authority, granted on the conditions imposed by the Board; but no cattle can be moved into or out of an infected *place*, excepting under the direct authority of the Board.

Every person moving cattle under licence shall on demand produce the movement licence.

It is incumbent on the local authority to report to the Board any herd of cattle within its district which has been in the same field, shed, place, or herd with any cattle affected with pleuro-pneumonia, or otherwise exposed to infection.

Important powers are given to local authorities, when specially authorized by the Board, to prohibit or regulate movements of cattle within the whole of their district, or any part of it, with the view of preventing the spread of pleuro-pneumonia.

In all cases the local authority have to send a copy of every regulation bearing on this matter, to each Railway Company having a station within the district to which the regulation applies.

All cattle affected with pleuro-pneumonia are destroyed by order of the Board, also suspects and in-contacts. For all animals destroyed compensation is given; for the affected it is three-fourths the value prior to attack, not exceeding thirty pounds; for all others their full value, not exceeding forty pounds. The cost of compensation is paid by the Board out of a Parliamentary grant.

The disposal of carcasses of those animals which have died or been destroyed is the same as that for Cattle Plague, with the exception that the local authority may make certain regulations for prohibiting or regulating the removal of carcasses, or for securing the burial and destruction of the same. Further, they may permit a carcass to

be buried or destroyed in the district of another authority with their previous consent.

The offences of digging up a carcass, and occupier failing to give facilities for cleansing and disinfecting the premises, are the same as for Cattle Plague.

If pleuro-pneumonia be found in a market, railway-station, or other place during transit, the animals may be seized by the local Inspector, also all in-contacts. They are detained where seized, or moved to a convenient quarantine station, care being taken to keep the diseased and apparently healthy apart. This action is to be reported to the Board, who alone can declare the place of seizure an 'infected place.'

All regulations made by the local authority under the Pleuro-Pneumonia Order have to be submitted to the Board, and the latter may cause the revocation of any they consider objectionable.

Prohibition to expose or move diseased or suspected animals is the same as for Cattle Plague (p. 498), excepting that the prohibition refers solely to cattle and no other animals.

The offences against the Act are practically the same as for Cattle Plague, but there is a special provision regarding the neglect of disinfection and cleaning.

#### FOOT AND MOUTH DISEASE.

Although the first visitation of this disease in Great Britain lasted from 1839 to 1886, it was not until 1869, viz., thirty years after its introduction, that it was scheduled as a contagious disease, and even then the orders were permissive, and left in the hands of the local authorities. During nearly a half-century of its first visitation, over 7,000,000 animals were affected, and in one year alone, 1871, nearly 700,000 cases of the disease were recorded, while the actual number attacked are said to have been probably double.

In 1873 a Select Committee of the House of Commons sat and went into the question of eradicating Foot and Mouth Disease, and finally reported that repressive measures would meet with such strong opposition, that they recommended the Privy Council to cease issuing orders for the repression of the disease!

In this Report the evils of 'local authorities' were also well portrayed; ninety-two county authorities, prepared to take an enlightened view of the situation, were blocked by

330 borough authorities who viewed the suggested measure of stopping importation of foreign cattle as an interference with free trade, and described it as 'protection' in disguise. The result of this was that nearly 750,000 cases of the disease were reported during the five years 1880-1884, and during this time no less than 7,037 cattle arrived in this country in an infected condition!

With all this experience before them the Government could not be got to act, they were begged to stop the importation from known affected countries, but the Foreign Cattle Trade Association was too powerful for them, and even enlightened members of Parliament declared publicly that prohibition of importation would raise the price of meat to 2s. 6d. a pound! Finally, in 1886, permissive legislation by local authorities was withdrawn, and the power to act centralized. The ports were closed against countries affected with Foot and Mouth Disease and the Plague was exterminated, the country remaining free from 1887 to 1891.

All this is very painful reading, and is given as supporting the contention at the beginning of this chapter, that if a Government would not listen to interested parties and to uneducated public opinion, but would accept the advice of experts whose business it is to know, what a saving to the wealth of the community and National Exchequer would follow!

It is hardly likely that outbreaks of foot and mouth disease can be entirely prevented, bearing in mind that the affection is always present on the Continent, the facility with which it is carried by human agency, and the extensive traffic which exists between the Continent and Great Britain. But we have nothing to fear from isolated outbreaks if they are firmly grasped, as those have been in recent years.

Of all the contagious diseases of animals, there is none where the virus is so persistent or so easily carried. Professor Simmonds was known to declare that he could carry it on the end of his walking-stick. A mysterious outbreak

in the Midlands was discovered to be due to a surveyor's measuring chain. An observation in the measurement of a healthy farm had to be repeated, after the chain had been employed in measuring one where the disease existed.

In the four outbreaks which have occurred in England since 1891, the germs of the disease have been imported from abroad, but the most rigid inquiry has failed to explain some of the outbreaks. Professor Bang of Copenhagen suggests that birds may easily carry the infection on their feet from place to place; this is supported by Simmonds' opinion given above, the story of the surveyor's chain, and the evidence of the Chief Veterinary Officer of the Board of Agriculture, quoted on p. 495, of the introduction of the disease by ships from non-affected countries, through using head-ropes from cattle which had previously been infected at the Cattle Market at Deptford.

The animals affected by Foot and Mouth Disease are cattle, sheep, pigs, and occasionally the human subject. The disease has a short incubative period, the symptoms are evident within a week, and the diagnosis is easy. The affection of cattle and sheep simultaneously, and the highly contagious character of the disorder admit of little doubt in diagnosis; as Professor McFadyean tersely puts it, 'in cattle a sore mouth and lameness is a combination only met with in Foot and Mouth Disease.'\*

The same authority points out three diseases of sheep which may be mistaken for foot and mouth—viz., contagious foot rot, malignant aphtha, and an eruption on the face and limbs of sheep, known in Scotland as 'Orf,' and he points out as a differential diagnosis that foot rot only as a rule affects one foot, malignant aphtha affects only ewes and very young lambs, while in 'Orf' the eruption is mainly on the face, nostril, and lip, and never inside the mouth; further, the disease, though contagious to sheep, is not so to cattle.

\* *Journal of the Royal Agricultural Society*, vol. lxii., 1901.

The stamping out of Foot and Mouth Disease must be carried out in all congested countries by means of destruction. Nothing must be left alive capable of conveying the disease, and if dogs and other smaller animals cannot be kept under control, they had better be destroyed.

Everything in contact with the sick, and all their evacuations are highly infective; these must be destroyed by fire. The attendants, butchers, etc., must be suitably attired for their work on the farm, and all clothes and boots must be left behind for destruction or disinfection; all persons before leaving an infected farm must be thoroughly disinfected. On no account should swine be neglected, they are liable to the disease and should be confined to their styes or destroyed.

The usual two zones constituting the affected area must at once be established, and all movements both in this and the affected district suspended. The area for Foot and Mouth Disease must be made exceptionally large, small areas are useless. Further, the embargo on all movements must be maintained for some time after the affected animal is destroyed.

The virus is known to have a vitality of about eighteen days outside the body, and it is easy to understand how it may be carried on the hoofs of animals for considerable distances before it becomes inert.

In the Annual Report of the Board of Agriculture for 1899, it is stated that some of the expert advisers of the French Government consider that the virus may retain its virulence for several months in sheds which are not disinfected.

Lymph from a vesicle kept in a capillary tube has been found active after three weeks, and kept in an ice-chest was virulent after three months.

Cattle houses, straw yards, and pastures are infected not only from the excreta, but also from the saliva; straw yards and pastures, owing to the difficulty of disinfection, must be given a considerable period before being again occupied, not less than three months, and if possible



longer. We are fully alive to the inconvenience and loss this entails on the owner, but it is inevitable, and for the public good.

Bearing in mind the opinion of Bang relative to birds carrying the virus on their feet, measures should be adopted where possible within the affected place to destroy or scare them away.

Attention to cattle trucks is imperative, likewise the entire destruction of all fæces, and litter in them. All forage on the farm or elsewhere which has run any risk of contamination should be destroyed, unless it can be consumed by horses.

In non-congested countries the disease may be treated and the affected stock rigidly isolated. The group system previously described (p. 495) must be enforced, all movements in and out stopped. All forage required for the sick which may have to be brought from a clean area must be drawn by animals not affected by the disease, and even then neither they nor waggons are on any account to be allowed within the outer cordon.

Disinfection of the sick and the ground on which they stand must be daily practised, and a long quarantine established, for safety not less than six weeks after the last case has recovered.

The standings of the sick, mangers, buckets, utensils, etc., must subsequently be thoroughly disinfected, and if the animals are in the open it would be well when possible to plough the land and get a crop off it. Under certain circumstances it may be possible to burn the surface of the ground.

During recent outbreaks in Great Britain, where the conditions have been favourable for complete isolation, the Board of Agriculture have permitted this to be done instead of destruction. There are but few places where affected stock could be so isolated as to be absolutely safe, and nothing less than 'absolute' should be accepted.

## LEGISLATION.

*The Diseases of Animals Act, 1894, and the Foot and Mouth Disease Order of 1895.*

The regulations regarding notification of the existence of disease, and the duties of the Inspector to act immediately, are the same as in Cattle Plague.

When it appears to an inspector of a local authority that Foot and Mouth Disease exists, or has existed within ten days, the place shall be declared infected, the occupier served with a notice, and also the occupier on any land or contiguous building.

There are special rules applicable to movements in Foot and Mouth Disease. Animals cannot be moved into or out of an infected place excepting by a licence of the Board.

Animals may be moved within an infected area by license of the local authority granted on conditions prescribed by the Board.

Inspectors are charged to prohibit the movements of any animal (all ruminants and swine) out of an infected place, or into an infected place. The owner or person in charge is also prohibited from allowing any other animal to come in contact with the affected or suspects.

Carcases\* may not be removed from an infected place excepting by written permission of an Inspector of the Board, or Inspector of the local authority.

Fodder, litter, manure, utensils, or other things may not be removed from an infected place, excepting by the written permission of the above officers, and then only after they have been thoroughly disinfected.

No person (excepting the person tending the animal) can without the written permission of the officers above named, enter any part of an infected place.

Every person leaving an infected place will wash his hands with soap and water, and disinfect his boots and clothes; special orders exist in this respect in connection with Inspectors.

If the local authorities are satisfied of the existence or past existence of Foot and Mouth Disease, they shall declare accordingly, and prescribe the limits of the place infected. They may, if they think fit, include any land or buildings adjoining, or any adjoining part of the district of another local authority, with the previous consent in writing of that authority.

The regulations with regard to destruction of Foot and Mouth Disease cases are permissive. The Board 'may if they think fit' in any

---

\* Under the Order this means carcase or part of a carcase, and includes bones, hide, hoofs, horns, offal, etc.

case cause the animals to be destroyed, both affected and in-contact, or any which may have been in any way exposed to infection.

Compensation for destruction ordered by the Board is different from what we have previously examined ; for animals the subject of the disease compensation is on the scale of full value immediately before it became affected :—in every other case the compensation allowed is in the value of the animal immediately before it was destroyed.

The money for compensation comes out of the pleuro-pneumonia account.

The above regulations regarding destruction of Foot and Mouth Disease cases is from the Diseases of Animals Act, 1894. The Foot and Mouth Order of 1895 states that a local authority may *if they think fit* cause any cattle, sheep or swine affected, or suspected of being affected, to be destroyed, also any in-contact or others in any way exposed to infection.

Compensation is given on the same basis as that paid out of the Imperial Funds, but in this case falls on the local rates.

The local authorities can withhold compensation if they think fit, for any animal destroyed by their order, which in their opinion was diseased when brought into their district.

No animals destroyed under the Foot and Mouth Disease Order, can be slaughtered in any slaughter-house where swine are kept.

It is a little difficult to understand slaughter being permissive in such a disease, or two different authorities being empowered to carry it out, the funds in each case being found from two distinct sources.

As a matter of fact in practically all cases slaughter is not permissive but obligatory, and compensation is from Imperial sources and not local rates.

The Orders regarding the disposal of carcasses of animals which have died or been destroyed are the same as in Cattle Plague.

The disinfection laid down for Foot and Mouth Disease is clearly defined.

1. The shed or other affected place is to be swept out, and all litter and manure effectually removed.
2. The floor or any other places likely to be affected by the saliva, fæces, urine, etc., is to be thoroughly washed, or scrubbed, or scoured with water, and then washed over with lime-wash.
3. All litter, manure, or other things removed from the shed, is to be destroyed, disinfected, or burnt.
4. Places, like yards, of such a nature as not to be capable of being so cleansed and disinfected, are to be cleansed and disinfected as far as practicable.

Disinfection and cleaning is as a rule executed at the expense of the local authority, but the local authority may cause the expense to fall on the occupier.

Local authorities may, if they think fit, during any scare arising from the existence of Foot and Mouth Disease in the country, require any shed, house, or yard, or other place used for the temporary keeping or detention of animals, prior to sale at any market, fair, or public or private place, to be cleansed and disinfected, the same to be done at the expense of the owner or occupier.

They can also compel the disinfection of all vans, carts, or vehicles for carrying animals, ropes or nets, or other apparatus used in the conveyance of animals to be disinfected.

If a person fails to obey these regulations of the local authority, the latter will carry it out and recover from the person concerned.

Local authorities may during the existence of Foot and Mouth Disease in the country make such regulations as they think fit to prevent the introduction of the disease into their district, from the district of any other local authority. Further, in the event of the disease finding its way into their district, they may make such regulations as they think fit for prohibiting or regulating the movement of animals within the whole or part of their district.

In doing this they shall notify the railway companies concerned.

Local authorities may prohibit or regulate the exposure for sale of any animals at market, fair, or auction or sale yard.

If an animal be found affected with Foot and Mouth Disease in any market, fair, sale yard, lair, landing place, railway, commonage, etc., it may be seized by the Inspector of the local authorities with all in-contacts; the whole being detained where seized, or removed to some convenient place for isolation, and the Board communicated with. Under the above circumstances no other animals shall be brought to that market or other place where the diseased animal was found, until it has been cleansed and disinfected, and the Veterinary Inspector's certificate obtained.

The prohibition to expose or move diseased or suspected animals is the same as in Cattle Plague. See p. 500.

The offences against the Act are those previously noted under Cattle Plague and Foot and Mouth Disease with the following addition: It becomes an offence not to cause to be destroyed any animal which has been so condemned either by the Board or local authority.

#### SHEEP POX.

A reference to the importation of this disease and its costly results exists on p. 470.

It is a specific inoculable disease, characterized by an eruption on those parts of the skin where no wool grows, such as inside the forearms, thighs, etc.

The Board of Agriculture regard the possibilities of this disease being re-introduced as very remote, nevertheless we reproduce the Orders bearing on the suppression of this epizootic.

## LEGISLATION.

*Diseases of Animals Act, 1894, and Sheep Pox Order of 1895.*

Notification of disease and action of Inspectors is as in previous diseases.

A place may be declared infected, even though no case of the disease exists, provided it is within ten days of the last case.

The local authority in prescribing the limits of an infected place, may include any adjoining place, or part of district of another local authority, provided this authority gives consent.

Sheep cannot be moved out of an infected place. Carcasses cannot be removed, excepting on a veterinary certificate that the animal was not affected with sheep pox, and then only provided the skin has been removed.

Diseased carcasses may be removed under licence for burial or destruction, the licence only being available for twelve hours, and specifying where the burial or destruction is to take place. This is carried out under the direction of the Inspector, who shall enforce the immediate burial or destruction of the carcass.

Carcasses may be buried or destroyed in the district of another local authority, with their permission and licence.

The skin, fleece, or wool of a carcass shall not be removed from an infected place except by veterinary certificate, which cannot be granted until they have been properly disinfected.

The above refers to sheep not actually suffering from the disease. Diseased sheep are buried six feet below the surface in their skins, previously slashed, and 'covered with a sufficient quantity of quicklime or other disinfectant.' Or under the licence of the Board the carcass may, after a preliminary disinfection, be removed under the care of the Inspector to an approved place, and there destroyed either by fire or chemical means. This may be carried out in the district of another authority, with their approval.

Sheep cannot be moved in any place where sheep pox has existed, until all the sheep are dead or destroyed, and the place properly disinfected.

Any place that has been occupied by diseased animals shall be cleansed and disinfected; litter, manure, and anything that has been in contact with and used about such sheep shall be disinfected, burned or destroyed—for example, hurdles, utensils, pens, etc.

The disinfection is carried out at the cost of the local authorities, or the latter can make the occupier pay, or do the work for him and charge him with the same. Occupiers have, under penalty, to give full facilities for cleansing.

Local authorities can make any regulation they think fit to prevent the spread of the disease through the medium of markets, fairs, sale-yards, etc.

If the disease is found among animals in transit, either in a market, railway-station, park, commonage, etc., they may be seized and dealt with by the local authority, and the place disinfected, the cost of the proceeding being recoverable from the owner or other persons concerned.

All sheep affected with sheep pox are to be destroyed within two days by the local authorities. All sheep suspected of being affected, or of having been exposed to infection, *may* be destroyed by the local authorities *if they think fit*. No slaughter-house can be used for this purpose where swine are kept.

Compensation is paid out of the local rates, half value not exceeding forty shillings, being paid for the affected.

In all other cases the compensation shall be the value before slaughter, but not exceeding four pounds.

A local authority may withhold compensation, if in their opinion the sheep was diseased at the time it was brought into their district.

It is an offence to expose diseased or suspected sheep in any public or private place where sheep are usually sold; or to place diseased sheep in contact with the healthy at any market or fair. To send sheep by road, rail, or otherwise if diseased or suspected is an offence to expose them in any way, on commonlands, fields, highways, etc., so that healthy sheep run a risk of infection, is unlawful.

It is an offence to move sheep in contravention of the Order; to remove or fail to bury or destroy a carcass; to omit anything with regard to cleansing or disinfection; to allow sheep to stray to avoid the operation of the Order; or to give a false name or address in connection with a movement licence.

#### SHEEP SCABIES.

In the chapter dealing with Parasites, we drew attention to the fact that all animals are affected by scabies, but in none does it assume such serious proportions as in the sheep.

Every continent and every country has suffered more or less from this pest. In countries where sheep-farming is a

large industry, the financial loss from this disease is extreme; so much has this been the case that Australia and New Zealand realizing the importance of getting rid of the scourge, practically banished it from the country by well-conceived regulations.

In this respect they are a profound object-lesson to the parent country, which has tolerated the existence of scabies among flocks for probably hundreds of years.\*

One of the earliest Acts on the Statute Book referring to the repression of contagious diseases among animals, deals with sheep scabies. It was issued in the year 1798, and

\* The Board of Agriculture having been approached by the Central Chambers of Agriculture on the necessity for freeing Great Britain from Sheep Scabies, were asked that the disease might be dealt with on the successful lines adopted in Australia and New Zealand. Advantage was taken by the Assistant Secretary in the Annual Report of the Animals Division of the Board of Agriculture 1902, to explain that it is a misconception of the facts to say that Australia and New Zealand adopted compulsory dipping, irrespective of the suspicion of the existence of sheep scab. He states the Colonial Regulations fail to show that any such precaution was adopted. Compulsory dipping was apparently confined to flocks in which a suspicion of scab existed, and success was evidently in large measures due to well directed restrictions on the movements of sheep.

The President of the Board of Agriculture deprecates taking any further action towards getting rid of Sheep Scab, but recommends local authorities to make more use of the powers given them in order to prevent its *spread*. In the Report of the Assistant Secretary of the Animals Division for 1901, the following remarkable paragraph occurs:

‘The progress hitherto made in dealing with the disease (Sheep Scab) in Great Britain has caused comparatively little inconvenience to trade generally, and if that progress is maintained for a few years, and the disease is then found to exist in only a small portion of the country, vigorous measures might no doubt, with great advantage, be adopted, to bring about its final extinction. It is, however, for flock masters themselves to consider whether they would prefer the stronger measures at once, or whether they are prepared for a time to cripple the sheep trade generally, in order to anticipate by a few years the disappearance of sheep scab.’

Such is the official opinion expressed in the Report for the year 1901, and with it is presented a map of Great Britain showing only 14 counties free from the disease!

constituted as an offence the turning out of affected sheep to graze on common lands. From that time to the present many Acts have been issued by the legislature, but none have aimed at anything more than the control of the disease, and for this purpose powers are delegated to the local authorities. This is insufficient, the entire eradication of scabies in sheep should be determined upon, and for this purpose the working of the Act must be centralized.

In the hands of local authorities no scheme however well considered can succeed, for whereas some will take full advantage of the powers conferred upon them, others maintain an attitude of indifference. There are 117 county divisions in the United Kingdom, so that the difficulty of obtaining concerted action under permissive legislation is easily understood.

Nor have we to look only to the United Kingdom for an example of the weakness of such a system ; the same exists in Cape Colony, and in spite of the fact that as far back as 1884 it was officially stated the annual loss in the Colony exceeded £822,000, yet local arrangements still exist, and the disease remains as prevalent as ever.

It has been urged that eradication in the United Kingdom is impossible, as the collection of sheep and their dipping in the mountainous districts of Scotland and Wales would be defeated by the fact that large areas of the country are unfenced, and a few stragglers left undipped would only act as centres of fresh infection. Against this it must not be forgotten that New Zealand had far greater natural difficulties to contend against, and yet overcame them. Fencing is all-important, and must be regarded as an essential factor in the matter, when the day arrives—as it must—for clearing the United Kingdom of mange. The fencing offers no difficulties ; let it be borne in mind that Cape Colony stretched a fence across a continent to keep out Cattle Plague.\* What, therefore, can be the difficulty, where tracts of counties are concerned no

\* The actual length of fencing employed was 2,082 miles !



larger than many a South African farm, which a man fences at his own expense !

There can be no doubt that for effectively dealing with scabies in sheep, fencing must be practised in those districts where the country is innocent of fences for many miles ; without this all the difficulties foreseen by men who are practically acquainted with these districts will arise—viz., the impossibility of collecting all the sheep.

Professor Wallace in a very able article\* dealing with the eradication of scabies in sheep, gives an example of the local difficulties which would occur in a Welsh mountain district, where 45,000 sheep, belonging to upwards of 300 different owners, are grazed. In the place mentioned the land possesses no fences over an area of 8 miles by 12 miles, and there is only a very limited time available for dipping this number of sheep. In such a case the breaking up of the country by fences is the only alternative.

One good colonial bath, giving a swim of 60 feet, will with sufficient labour put 4,000 sheep through in one day, or the whole lot could be put through one bath in less than twelve days. Bearing in mind that the consensus of opinion in Great Britain points to the annual migration of sheep from the mountains as being a serious source of infection, and one which is the most difficult to control, it is evident these districts must be fenced if the work is to be properly and economically done.

Even when sheep scabies is brought under central administration it will take a few years to eradicate it, and it is economy to start on a sound basis ; it is probable that it may take at least four or five years to render the United Kingdom free from disease.

There are certain conditions associated with scabies, which render it a contrast to other epizootic diseases, and on which it is well the public should be well informed.

In the first instance it is a curable disease, it is not a question of taking over a disease which offers a reasonable

\* 'Scab in Sheep': *Transactions of the Highland and Agricultural Society*, vol. xii., 1900.

prospect of cure ; speaking broadly, it offers a certainty of cure.

The disease is not dependent on a microscopic organism which defies high magnifying powers or laboratory filters ; it can under favourable conditions be easily seen with the naked eye, so that even the dullest intelligence can grasp the cause. It can never arise spontaneously, but can only occur as the result of contagion, and this elementary fact requires more pressing home on the public mind than either of the others, for it is the basis of intelligent co-operation.

If flock-masters could be taught these three simple facts, the first step towards eradication would be accomplished ; we shall now consider them in somewhat greater detail.

The curability of the disease is undoubted ; there are many remedies, fortunately all inexpensive, which are available. While some pin their faith on sulphur and lime, as Australia did, others, like Cape Colony, select something more active in the shape of arsenic ; while tobacco, or preparations of carbolic acid also find favour. It does not appear to matter what dip is employed so long as its application is thorough. Professor Wallace, in the paper previously alluded to, speaks highly of the value of tobacco dips, especially for preventing further infection from 'rubbing places,' and thinks this remedy will be absolutely essential for eradicating the disease from mountainous places. If tobacco is to be largely used, some special excise regulations will have to be made in order to obtain it at a reasonable rate.

The sulphur and lime method is no doubt excellent, but inasmuch as the two have to be boiled together, it may not always be a convenient dip to employ. It is made by boiling 25 lbs. sulphur in 20 gallons of water, with 18 lbs. slacked lime for 20 minutes, and then diluting to 100 gallons.

The insolubility of arsenic is overcome in certain proprietary dips which have a large sale, and are of the greatest value and convenience. Arsenic in the strength of 2 lbs. to 100 gallons of water may be safely employed.

Non-poisonous sheep dips of the phenol group may be used, and these also form the subject of convenient proprietary preparations.

Whatever substance is employed a certain length of contact is required in order to destroy the parasite, and complete immersion of the body in the solution, including the head, is an absolute necessity. From one to two minutes' immersion, depending on the agent employed, is necessary for the destruction of the parasite, though it by no means follows that this is sufficient to destroy all the eggs. The latter are deposited under the crusts formed by the disease, where they are moderately safe from parasiticides. The female acarus takes 15 days to become an adult; she lays about 15 eggs which are hatched out in two or three days, and of these eggs two-thirds are females. One pair of mature acari will produce a progeny of 1,500,000 acari in three months.

A second dipping is therefore essential to kill off the acari which as eggs escaped the first dipping, and the second dipping may be repeated fifteen days after the first.

Some other facts regarding the acarus of this disease are also important to bear in mind, both from a therapeutic and legislative point of view. There is no doubt of the remarkable vitality of the organism apart from the body; mature acari have been known to live on rubbing places for 21 days, also in dry earth and manure, while on the authority of Professor Wallace it is said the eggs may retain their vitality for years.

These facts show how easy it is for a flock to get re-infected, and explain, perhaps, what the lay mind finds it so difficult to disbelieve, that is the apparent spontaneous origin of the disease. All rubbing places, gates, posts, hedges, etc., are sources of fresh infection, even the pieces of wool torn out by the animal during the rubbing operation are liable to re-infect. Yet in spite of these sources of infection the disease, as we have seen, may be eradicated, but it strongly points to the necessity for regular dipping; and this, in fact, is done in Australia in

spite of the absence of the disease, by which means other parasites, such as the sheep louse, are destroyed.

The complete eradication from the United Kingdom of scabies in sheep is a matter of time, so numerous are the sources of reinfection. Even if every animal in the country could be twice put through a bath, there is still the risk of reinfection from contaminated pastures, though far less risk than from contaminated sheep. The medication employed in dipping affords for a time a certain amount of protection, which to an extent neutralizes the risk of reinfection from contaminated pastures. All sheep countries recognise that whether sheep are or are not affected with scabies, an annual 'dip' is essential, and in this way after eradication the chances of further infection are greatly minimized.

There can be no doubt of the magnitude of the proposed task to eradicate scabies from the United Kingdom; in point of size and numbers to be dealt with, it cannot be compared with Australia, but the density of the population, its urgent demands, its old non-progressive sternly conservative spirit of opposition to all restrictions and freedom of movement, will give far more trouble than the dipping of twenty-five and a half million sheep, which practically represents its ovine population.

Yet the problem has to be faced, and within recent years the Legislature has paved the way by the introduction of some measures of the utmost importance:

1. The slaughter of all foreign sheep at the port of landing.
2. The powers given to local authorities to make agreements between themselves regarding the uniting of their districts, so as to form one large district in which uniform regulations may be enforced.

These are two most important conditions; infection from without is prevented, and districts or areas can be created, where simultaneous action can be adopted, and in which local conditions and systems are probably closely allied.

The next important measure is provided by a recent Act of Parliament. The essence of the system of eradication depends upon curing the disease, and as a cure can be effected by dipping, it is clear that what the Legislature has to provide for, is the effective dipping of all animals in the country. A step has been taken in this direction by the Diseases of Animals Act, 1903, which empowers the Board of Agriculture to make regulations for securing the periodical treatment of all sheep by dipping. As this can only be carried out at certain seasons of the year, the system must be supplemented by the regulation of movements and isolation, and it is here the hardship, inconvenience, disorganization of trade, and financial loss direct or indirect, are felt by individuals.

This, however, must be met; if owners of sheep fail to keep their flocks free from an easily curable and preventable disease through want of united action, the State must do this for them, and the inconvenience of central control will be experienced by both the careful and the indifferent.

The compulsory dipping should be carried out under the supervision of trained officers of the Board of Agriculture. Baths of the colonial pattern, which give a long swim, would have to be erected all over the country; the usefulness of these would not terminate with the extinction of the disease, for annual dipping should be compulsory, and at the expense of the owner.

Mr. Hedley, Chief Veterinary Officer of the Irish Department, is opposed to compulsory dipping as creating dissatisfaction, but would limit it to affected districts and areas.\*

There are other conditions essential to success. Infected areas if unfenced must be fenced. Outbreaks must be reported on pain of substantial penalties, and no regard should be paid as to whether the outbreak is situated in one county or another, but the whole area should be declared infected, both around the affected place and for a sufficient distance away. Within the affected area the whole of the

\* Sheep-dipping Committee, 1904.

sheep must be dipped, and as far as possible the place disinfected.

The quarantine to be imposed on an area may be raised after three months, if no fresh cases of the disease have occurred.

During the period of quarantine any attempt to remove sheep from the farm must be met by a substantial penalty, and any opposition on the part of the owner to dipping his affected flock, after the expiration of a reasonable time, must be met by the State taking it in hand, and recovering from the owner.

The main principles aimed at here are to compel all sheep owners to dip their sheep, and then by central control grapple thoroughly with every centre of infection, cutting it off from markets, fairs, or any form of live sheep sale, until it is free from disease.

Failure to notify the existence of scabies must be made the subject of a heavy penalty, as every shepherd knows the clinical features of the disease. Power should exist to inflict severe penalties in those cases where owners have parted by sale with affected sheep, which only act as further centres of infection.

Purchasers may, however, protect themselves by establishing the systematic dipping of all newly-purchased sheep, before allowing them to mix with their clean flock. Where fresh centres arise as the result of sales, the Veterinary Inspector should prosecute the most rigid inquiry, inspecting all flocks belonging to suspected owners; in other words, the cases must be traced to their origin, and full punishment inflicted. Section 2 of the Act of 1903 provides for the compulsory inspection of sheep for the purpose of any regulation of the Act.

All who have given the question of eradication any attention, realize that the measures are best introduced gradually. Professor Wallace suggests two or three years for compulsory dipping, during which time the farmers seeing its effects, would be won over for the supreme effort of the simultaneous dipping of large areas. There are others who

would make the period shorter, giving the farmers warning of what was about to follow, inviting them to dip their sheep, and giving them a certain number of months to get their flocks clean.

Under either conditions a uniform system of regulations applicable to the whole country must be adopted, and therefore not under local authorities.

The duties of the latter must be confined to providing 'baths' at the most convenient centres, and here their local knowledge is useful. The cost of these should be defrayed by the charge made for dipping and not out of the local rates. Under the Act of 1903 it is rendered permissive for local authorities to provide dipping-baths.

The proper time for universal dipping is after shearing, as a full grown fleece greatly hinders the penetration of the parasiticide.

The following considerations regarding dipping should be borne in mind :

1. Sufficient immersion, one minute for ordinary sheep, two minutes for those affected with scabies ; during the swim the head to be at least twice pushed under. If a long swim bath is not available, the dipping must be done by the watch, and in the smaller or portable baths, where the work is being done on a small scale, it may be necessary to rub the 'dip' well into the skin.

2. In a properly constructed bath there is a place where the animals stand while the fluid drips from the skin, and this by a simple arrangement is returned to the bath. Where the number dealt with is small, the superfluous fluid may be pressed out with the hand.

3. It is best for the sheep to be dropped in head first, not only to insure thorough immersion, but the risk of swallowing fluid is much less.

4. Very hot or wet days are not good for dipping purposes ; nor should sheep be dipped either when they are hot or thirsty.

5. After dipping they should remain in properly constructed pens for an hour or two until it is safe to allow

them to return to their pasture. Should rain come on they must remain in the dripping pen until it has ceased. These precautions are mainly applicable to poisonous 'dips' like arsenic. Rain washes out the arsenic: in fact with all dips the evil effects of rain are very evident, for one of the objects aimed at is to leave sufficient material in the wool to act as a preventive for some time to come.\*

A very practical point in connection with general dipping is mentioned by Professor Wallace, and that is the subsequent difficulty of recognition between ewes and lambs. The ewe recognises her offspring by its smell, but this is destroyed by dipping. There is always some difficulty in their mutual recognition after shearing, but all doubt is removed by the sense of smell; after dipping the distinctive smell is lost, and Wallace says competent authorities estimate that in the case of large flocks running wild in an upland country, probably one-third of the lambs after dipping would never find their mothers.

In dealing with an outbreak of scabies on a farm the sheep are grouped according to degrees of severity, and in this way in-contacts are separated from the affected. If the time of year admits of shearing being done this should be carried out, if not the bath must be used on the unshorn skin. In-contacts should first be dealt with, and subsequently placed in a pen by themselves; the other groups may then be dipped in the order of severity, leaving the worst cases until the last. By breaking up the flock into groups not only is the supervision more effective, but the spread of the disease is prevented.

All rubbing places, posts, rails, etc., must be disinfected, loose wool collected and burned, and the animals kept penned until safe to mix with the healthy. Thorough disinfection of all hurdles used as pens must be observed. One important point to attend to in curative measures is

\* The principle of a sheep bath may be gathered from the figure of a cattle bath shown on p. 423. It should give 60 feet of actual swim, so as to insure sufficient immersion. The depth of the bath to be  $5\frac{1}{2}$  feet, the width 2 feet at the water-level, and 9 inches on the floor of the bath.



the liberal feeding of affected sheep. Sheep poor in condition are not only more susceptible of the disease, but are more difficult to cure.

In the extinction of scabies from the country, the influence of railway trucks as a source of infecting healthy sheep must not be overlooked. In the early stage of the disease there is nothing to seriously attract attention, and sheep believed to be free from scabies may be sent by rail and thus infect the trucks. Much the same may occur in sheep pens in markets.

In both the above cases the most rigorous system should be adopted to disinfect these places after occupation, no perfunctory measures are of any use. Each truck and each pen should be thoroughly dealt with on the lines laid down in the chapter dealing with disinfection.

#### LEGISLATION.\*

*Diseases of Animals Acts, 1894-1903, and Sheep Scab Order of 1898.*

*Diseases of Animals Act, 1903.*—Is an Act to amend the Diseases of Animals Act of 1894 in relation to sheep scab. It empowers a fresh sub-section to be added to Section 22, given in detail on pp. 481-484. The fresh sub-section is numbered xiii*a.*, and reads as follows:

‘(xiii*a.*) For prescribing, regulating, and securing the periodical treatment of all sheep by effective dipping, or by the use of some other remedy for sheep scab.’

Under this Act an Inspector of the Board and an Inspector of the local authority may under authority enter any premises, and examine any sheep, for the purpose of any Order or Regulation of this Act. The owner and person in charge of the sheep must comply with all reasonable requirements of the Inspector, as to the collection and penning of the sheep for examination.

The local authority may provide, fit up, and maintain portable dipping tanks, or, if sanctioned by the Board, dipping places may be erected. The local authority will also provide the necessary appliance and material in connection with these baths, and charge the public for the same. The Act provides that no dipping-place shall be used, if it would injuriously affect the water-supply for drinking or domestic purposes.

The Act applies to Great Britain and Ireland.

---

\* See also Appendix.

*Sheep Scab Order of 1898.*—Notification of disease and action of Inspector as before.

The local authorities on receiving information of the existence of the disease, shall cause enquiries to be made as to the correctness of such information. This regulation holds good for all the diseases previously considered, but for Sheep Scab there is a special regulation rendering it an offence for the owner or occupier of the premises not to give all reasonable facilities for enquiry.

If the local authority is satisfied about the existence of the disease, it is their duty to take steps to secure the isolation of the affected or suspected sheep, and of any which have been in the same flock, field, yard, or place, with affected or suspected animals. A notice is served on the owner or person in charge, requiring such sheep to be detained in the place specified, and it then becomes an offence to move sheep affected or otherwise out of such place, or to move any other sheep in, or permit any other sheep to come in contact. Nor can carcasses, manure, fodder, wool, skins, or anything which have been in contact with the sheep to which the notice applies, be removed without the written permission of the Inspector.

Where the Inspector considers the movement of sheep elsewhere is desirable for the purpose of isolation, feeding, or other necessary purpose, a notice is served on the owner or person in charge to this effect, and the sheep are then moved by a route indicated by the Inspector, and there detained and isolated.

No notice of isolation so served can be withdrawn until the Inspector certifies the sheep are free from disease. While under detention the Inspector may request the owner or person in charge to cause all sheep to be treated in his presence, and to his satisfaction, with some recognised dressing, provided that they have not been so treated during the previous fourteen days. It is an offence to fail to comply with this regulation.

Any place in which a sheep affected or suspected of scabies has been kept, must be disinfected; all utensils, pens, hurdles, or other things used for about such sheep shall also be dealt with. The disinfection shall be at the expense of the owner or occupier of such place.

The method of disinfection prescribed is :

1. All litter, manure, or other thing in contact with the sheep shall be removed, and the place swept out.
2. The floor and all other parts shall be thoroughly washed, or scrubbed, or scoured with water.
3. The same parts are then to be lime-washed, or other disinfectant approved by the Inspector.
4. In the case of a field, yard, or other place not capable of being thoroughly cleansed and disinfected, whatever is practicable in

the way of cleansing and disinfection must be done to the satisfaction of the Inspector.

5. Every pen, hurdle, utensil, or other thing used about such sheep shall be cleansed and disinfected to the satisfaction of the Inspector, by being washed, scrubbed, scoured with water, and washed over with lime-wash, prepared from freshly-burned lime, or some other disinfectant approved by the Inspector.

If the owner or occupier fails to comply with these regulations, they are to be carried out by the local authority at his expense. If he fails

*Slip to be inserted at 'Sheep Scab Order,' p. 528.*

The Sheep Scab Order of 1898 has been revoked by those of 1905. See Appendix I.

be slaughtered, in which case it is done under the direction and in charge of the Inspector, or other officer deputed for the purpose, who shall enforce their immediate destruction.

#### SCABIES IN EQUINES.

Scabies in equines occasionally prevails as an epizootic, though more frequently as an enzootic. Among armies in the field it is a veritable plague, and occasions the utmost inconvenience and trouble.

It is a disease which is not scheduled in Great Britain, though there are one or two places to which local Acts

*Sheep Scab Order of 1898.*—Notification of disease and action of Inspector as before.

The local authorities on receiving information of the existence of the disease, shall cause enquiries to be made as to the correctness of such information. This regulation holds good for all the diseases previously considered, but for Sheep Scab there is a special regulation rendering it an offence for the owner or occupier of the premises not to give all reasonable facilities for enquiry.

If the local authority is satisfied about the existence of the disease, it is their duty to take steps to secure the isolation of the affected or

... must be disinfected, all utensils, pens, hurdles, or other things used for about such sheep shall also be dealt with. The disinfection shall be at the expense of the owner or occupier of such place.

The method of disinfection prescribed is :

1. All litter, manure, or other thing in contact with the sheep shall be removed, and the place swept out.
2. The floor and all other parts shall be thoroughly washed, or scrubbed, or scoured with water.
3. The same parts are then to be lime-washed, or other disinfectant approved by the Inspector.
4. In the case of a field, yard, or other place not capable of being thoroughly cleansed and disinfected, whatever is practicable in

the way of cleansing and disinfection must be done to the satisfaction of the Inspector.

5. Every pen, hurdle, utensil, or other thing used about such sheep shall be cleansed and disinfected to the satisfaction of the Inspector, by being washed, scrubbed, scoured with water, and washed over with lime-wash, prepared from freshly-burned lime, or some other disinfectant approved by the Inspector.

If the owner or occupier fails to comply with these regulations, they are to be carried out by the local authority at his expense. If he fails to give all reasonable facilities to the local authorities for this purpose, it constitutes an offence.

Local authorities may make such regulations as they think fit for preventing the introduction of sheep scab into their district, by prohibiting or regulating the movements of all sheep into their district from the district of any other local authority.

Similarly, they may make such regulations as they think fit, with the view of preventing the spread of disease within their district. Under both circumstances they are compelled to send a copy of the regulations bearing on the point to the railway authorities of the district.

Local authorities may prohibit or regulate the exposure of sheep at any fair, market, sale-yard, etc., in order to prevent the spread of disease.

Sheep affected with scabies, and exposed for sale in a market, fair, or elsewhere, or exposed while affected with the disease anywhere calculated to be detrimental to the public, shall be seized by an Inspector, together with all in-contacts, and isolated. The place where they are seized is not to be used again for sheep until an Inspector has certified it has been thoroughly disinfected and cleansed, the expenses connected with which are recoverable from the owner.

At the request of the owner or person in charge sheep so seized may be slaughtered, in which case it is done under the direction and in charge of the Inspector, or other officer deputed for the purpose, who shall enforce their immediate destruction.

#### SCABIES IN EQUINES.

Scabies in equines occasionally prevails as an epizootic, though more frequently as an enzootic. Among armies in the field it is a veritable plague, and occasions the utmost inconvenience and trouble.

It is a disease which is not scheduled in Great Britain, though there are one or two places to which local Acts

apply. In Ireland, on the other hand, it is scheduled; very admirable regulations exist to prevent its spread, and moreover to insure it being treated.

The most common variety of mange in equines is psoroptic, the most difficult to cure is sarcoptic. There are certain conditions favourable to the spread of the disease, of which those most in evidence are exhaustion and emaciation. Of course, the disease only spreads by contagion, but the rate of its spread is enormously influenced by debility and want of general care.

Animals in good condition and those with a clean skin have relative immunity, at any rate from psoroptic mange, though these appear to afford no resistance to the more severe sarcoptic variety.

Where the parasite exists during the period of non-infection is by no means clear, it may be in the soil, but it is certain that where a body of animals is placed under favourable conditions, the disease appears in the most remarkable way, even when no previous case can be traced.

There is no reason why the parasite should not live in the soil in the egg state, or even as a mature insect; we have seen this in the normal habitat of other blood-sucking insects like ticks, which can live for weeks and months without food while awaiting a host.

It is quite certain that the eggs or the parasite itself may live in other places besides soil, woodwork for example, and be capable of infecting animals. The practical bearing of this is of the utmost importance; blankets may convey the disease weeks after they have been used for affected cases, while the woodwork of stables, horse fittings on board ship, or railway trucks may harbour the eggs or parasites for a considerable time.

In fact, if this were not so, it would be difficult to account for outbreaks of disease which occur from time to time without any known direct infection having occurred.

Psoroptic scabies always spreads rapidly among animals in impoverished condition, but it spreads with extraordinary

rapidity when horses are huddled together in railway trucks, or on board ship, and this is what might be expected from our knowledge of the parasite.

Sarcoptic mange is slower in its spread, but as before indicated, infinitely more difficult to treat.

Symbiotic mange is also slow in progress and it is limited to the region below the knees and hocks. It is a disease confined to the hairy legs of the coarser breed of horses, and its importance is not great.

The *prevention of scabies* is a matter entirely under hygienic control; if the disease occurs in a stud or body of horses there is something wrong. Of course the affection may break out as the result of introducing an affected case, but as indicated above there are cases of the disease in which infection from without cannot be traced, and such are put down as the result of neglect.

If our supposition is correct that the acari of mange have a saprophytic existence, and only need favourable conditions to become parasitic, then we can account for many outbreaks of mange the result of sanitary neglect.

By far the most favourable condition is a dirty skin; horses with long coats are very difficult to groom in the winter, and a long and dirty-coated horse is a most favourable subject for the disease. Clipping as a preventive in cases of this kind becomes a hygienic necessity.

As might be expected, it is not the working horse with the long dirty coat which is so liable to the disease as the idle horse. An idle horse is always dirtier than a working horse, even when they each receive the same amount of grooming; work by its action on the skin helps to keep it clean. Dirty skins associated with a debilitated state of the body are a most favourable combination for the production of the disease.

Neglect of grooming, want of general care, and insufficient food, are the predisposing factors for mange. Given these, the production of the disease as an enzootic is only a matter of a short time.

With long-coated working horses the labour of grooming

must be saved by clipping, which, apart from its other advantages, enables the animal's skin to be kept clean with a minimum of trouble.

Though a dirty skin is rightly held as an important factor in the production of disease, it is well to bear in mind that two parts of the body which are seldom clean, even in a well-kept stable, viz., the mane and tail, are never attacked by the disease. The hair from both these parts may be rubbed away by the diseased animal scratching itself, but neither are affected by mange. To remove the hair of the tail from a mange case is a grave misapprehension. It would appear in fact that the mange acarus of equines avoids those parts of the body where only permanent hair is found.

Debility and neglect are the predisposing factors of the disease, they are not the cause of it. Where the actual cause comes from in all cases it is difficult to say, but we are convinced that some horses store up on their skin the eggs of the acari, and from time to time break out. Without this explanation it is difficult to account for recurrent cases of mange in animals, apparently perfectly cured each time, and not in the meanwhile exposed to reinfection.

Such cases, of course, are in the minority, and are only mentioned here as illustrating a point in infection. By far the majority of cases are only attacked once, and no return of the disease need be apprehended unless exposed to fresh contagion. In the same way the majority of outbreaks can be traced to infection from a previous case, either direct or indirect through the medium of blankets, saddle, harness, grooming gear, bedding, or other ways.

When psoroptic mange breaks out in a body of horses half measures are no use, systematic and radical methods must be adopted. It will probably be found to occur during the winter months, and such measures as the abolition of bedding and blankets may be objected to, but it is an absolutely necessary measure.

The first thing is to examine every animal, and adopt the group system of affected, doubtful, free from disease.



These classes must be kept apart, and the animals constituting it pass from one to the other as occasion arises.

It is best to begin treatment with the doubtful cases, clipping them all over from ears to heels, no matter how cold the weather. The clipping machine must be disinfected between each case by being left in paraffin oil for a short time, otherwise the risk of infecting cases by clipping, which turn out to be free from disease is very great.

Immediately after clipping they are dressed with any of the recognised remedies. While the clipping and dressing are being carried out the bedding is destroyed by fire, and the whole stable disinfected with 5 per cent. Izal or carbolic acid sprayed over the walls, mangers, stall partitions, posts, flooring. The parts are then washed with freshly prepared carbolized lime including the floor, and the freshly clipped and dressed animals can with practical safety be put back in their stables.

The feeding and daily exercise of the animals under treatment must be carefully observed. Every mange case must be exercised daily in order to get the skin to act, but as no blankets are to be allowed the horses must be brought back cool to the stable.

It is no part of our province to deal with the question of treatment, but it is permissible to notice that over-treatment and excessively irritating dressings must be avoided. The use of linseed oil to the skin as a basis of treatment, especially in hot climates, is only making a rod for one's own back, for the linseed oil blisters the animals, especially if in the sun (probably due to mustard oil as an adulterant), and further, by its oxidation, forms a varnish on the hair and the skin most difficult to remove.

Bedding should not be allowed for at least a month, and not in any case to horses actively affected. Blankets should not be permitted until the last case is cured.

It is obvious that all articles used in grooming should be disinfected, for which purpose a large vessel containing disinfectant should be kept in each stable into which brushes, rubbers, curry-combs, etc., are placed immediately

after use, and prepared by disinfection for the next day's grooming.

There is no epizootic of the horse which requires more manual labour than dealing with an outbreak of mange, and if sufficient does not exist more should be engaged, or the disease will hang about for some time instead of being at once nipped in the bud.

Sarcoptic mange is only cured with difficulty and is a slow process; the same hygienic measures are required, and also considerably more patience.

The chief measures in dealing with any outbreak of scabies may thus be summarized :

1. Grouping the cases.
2. Disinfection of stables, blankets, harness, and grooming material.
3. Clipping and dressing affected animals.
4. Entire abolition of blankets and bedding.
5. Liberal feeding and daily exercise of affected.

The method of disinfecting a large number of blankets is given at p. 410. This should be most scrupulously carried out immediately after the outbreak and again before the rugs are taken into use.

#### LEGISLATION.

##### *The Parasitic Mange (Ireland) Order of 1900.*

This order applies to horses, asses, and mules; parasitic mange in equines is, therefore, in Ireland a scheduled disease, though it is not so in Great Britain, but there are local Orders in existence affecting Cornwall, Warwickshire, Devonshire, Manchester, Salford, Aberdeen, Sheffield, and Glasgow.

The Order provides for the usual notification of disease, the duties of the Inspector, the isolation of the diseased, the prohibition of all movements in the affected place, and on public thoroughfares.

Contravention of the regulations regarding movements on a public thoroughfare, leads to the seizure and isolation of the affected, and the local authority may recover summarily the expenses in connection with this.

The Order also insists on the treatment of affected animals, and failure to comply constitutes an offence.

The usual regulations regarding cleansing and disinfection exist, and failure to comply with these imposes the obligation on the local authorities, who can recover from the owner.

The Order is a most enlightened and beneficial one.

#### SWINE FEVER.

This disease was imported into the United Kingdom about 1858, or a little earlier, and was detected and recognised about 1862. From that time up to 1878 it was allowed to run unchecked, while fresh importations of diseased stock were permitted from abroad.

In 1878 it was included in the Contagious Diseases of Animals Act, by which compulsory destruction of the affected was ordered, with compensation from the local rates, while movements from an infected place were prohibited.

An important question affecting the whole kingdom was again left to the wisdom of the local authorities, with the usual results. In 1879 further powers were given to the same authorities, which made provision for the declaration of infected places, the destruction of in-contacts, and regulations regarding the exposure for sale, of swine in fairs and markets. In 1882 still further powers were given local authorities, by which they could prohibit or regulate the movements of swine into their district from any other district.

In 1884, yielding to the natural objection of local authorities to have their rates saddled with compensation for compulsory destruction, an Order was published which left the destruction of diseased and in-contacts to the discretion of the local authority, and if the latter wished it a Swine Fever infected circle around an infected place could be declared by the Privy Council. In 1885 owing to an alarming increase of disease, attributable to the purchase of swine at fairs and markets, an Order was published which prohibited the sale of swine excepting for slaughter within three days, while sales could only be held on the premises in which the swine for sale had been kept not less

than twenty-eight days. In the same year the Swine Fever Compulsory Slaughter Order came into force but was revoked after a few months. There was also revoked an Order regarding the sale of swine, by which this could be held only under definite conditions, and by licence in certain districts. From 1886 to 1893 the policy of drift was pursued, when finally, under pressure, the Central Authority took up in the latter year the unenviable task of stamping out the disease they had allowed to spread throughout the Kingdom.

In 1893 a Departmental Committee was appointed to enquire into the provisions of the Contagious Diseases of Animals Act, in so far as they related to Swine Fever, and this Committee recommended the work of exterminating the disease should be placed in the hands of the Central Authority, and to give effect to this recommendation a Swine Fever Act came into force at the end of 1893. This Act constituted the Board of Agriculture the Central Authority, and empowered them to slaughter and pay compensation.

For two years and a half—viz. up to 1896—the Central Authority relied on destruction of affected and in-contacts, but unaided by restrictions on movements of swine in infected localities, with a result that the returns showed an increase instead of a diminution, while the money spent on compensation was considerable. In 1896 the Swine Fever Infected Areas Order came into force which made it illegal to move any pig within the prescribed area unless it appeared to be healthy, had been on the premises twenty-eight days, and during that time had not been exposed to contagion. Later in the same year a less stringent regulation was issued, known as the Swine Fever Suspected Zones Order, it dealt with movements of swine in localities in which it was believed unreported cases had recently occurred.

The effect of the above orders of 1896 were very apparent in the return for 1897, but in 1898 another rise occurred probably due to a relaxation of restrictions, while in 1899

a fresh departure in dealing with outbreaks was begun, by which a narrower meaning was given by the Board of Agriculture to the terms 'diseased,' and 'exposed to infection,' so that fewer animals were destroyed in each outbreak than was formerly the case, and swine, which under the old system would have been destroyed as suspects, were now allowed to live and be eventually set at liberty.

From 1900 up to date there have been other Orders issued which are alluded to later on, the effect of which has been to keep the disease under control (with the exception of 1901, when the outbreaks were nearly double), but this is hardly what was expected by the country considering the enormous outlay in compensation.

The object of introducing this history of the disease\* is owing to the fact that swine fever is still with us, and at present shows no sign of being exterminated; further, it is a good object-lesson of legislative weakness, and the almost criminal action of entrusting such grave matters as the suppression of animal plagues to the unskilled and often unwilling hands of local authorities. Even allowing for the years of neglect from the time of the introduction of the disease, yet there can be no doubt had the matter been taken up by the Central Authority in 1878, and firm instead of vacillating measures adopted, a very different story could now have been unfolded.†

\* In this account of the legislative history of Swine Fever, I am greatly indebted to two articles dealing with the question in the *Journal of Comparative Pathology*, vol. xv., No. 1, 1902—one by Mr. Berry, F.R.C.V.S., the other by Professor McFadyean.

† It is interesting in this connection to read what the Board of Agriculture has to say about its own inability to enforce the law.

The following occurs in the Annual Report of the Assistant Secretary for 1901 :

'But the increase of disease (Swine Fever) was mainly due to the strenuous resistance offered, both by local authorities and stock-owners throughout the country, to the general restrictions which had brought about a considerable decrease of the disease towards the fall of the preceding year, and to the fact that the effort of the police and others entrusted with the enforcement of such regulations had, during the winter months, been somewhat relaxed.'

What are the facts regarding swine fever which have a direct hygienic bearing?

First and foremost it is a contagious disease due to a specific organism. It cannot arise spontaneously, though this was affirmed by a Cabinet Minister responsible for the Agricultural Department. It can only arise as the result of contact with infection from a pre-existing case of the disease.

If this is not fully recognised, and the country prefers to accept the Cabinet Minister as a pathologist, then it is absolute waste of money giving compensation. There is

Again :

'So soon, therefore, as the disease declines in a district, determined resistance is offered to protective restrictions, with the result that necessary precautions are either withdrawn or neglected, with the inevitable consequence that the disease soon flares up again and spreads rapidly.'

The same official's report for 1902 is in a similar strain. After explaining the advantage of imposing rigid restrictions on the movements of swine, and recognizing that the spread of the disease is due to movements, he goes on to say that certain restrictions imposed in Cheshire and Somerset had been tried with good results.

'In view of these facts the Board determined to recommend generally to local authorities action on similar lines. This course was taken in preference to direct action on the part of the Board, because it was held in such matters the local authority were best able to judge the special needs of their own district, and trade of their locality.'

\* \* \* \* \*

'It rapidly became apparent that, with a few regrettable exceptions, local authorities were ready to fall in with the views of the Board in this matter, as far at any rate as movements of swine into their district were concerned, and in these circumstances it was thought desirable to frame for the assistance and guidance of local authorities a set of Regulations.'

It seems beyond belief that a Government Department charged with carrying out the law, under a strong Act of Parliament, can plead such a case!

We are clearly told that the local authorities fight against the law they are called upon to administer, and yet in face of this they are entrusted with carrying it out, as in the opinion of the Board of Agriculture they (the local authorities) are the best judges of the special needs of their own district!

no use in compensating a man for destroying his pigs, if the feeding of others on 'swill and wash' can produce the disease spontaneously, as has actually been stated by a Minister responsible to the country for all matters connected with the contagious diseases of animals!

The organism producing the disease is perfectly well known, and to make light of or ignore its existence, and its extreme infectivity, will not help to get rid of swine fever.

Infection is probably always brought about through the digestive canal, by food or earth soiled by the excreta of affected animals; after a variable incubative period, of from ten to twenty days, the disease develops. If very acute 80 per cent. or 90 per cent. may die, if less acute 50 per cent. or 60 per cent., while probably in all outbreaks there are some animals that though affected never develop any decided symptoms of the disease.

Years of experience have taught the important lesson that pigs may suffer from the disease in a chronic form, that is to say, may actually be affected with the disease, and give no pronounced evidence of it. Nor is this confined to swine fever, it is just as evident in glanders, tuberculosis, and pleuro-pneumonia. From a point of view of repression of swine fever by legislation, this is of the utmost importance. The *Swine Fever Infected Areas Order of 1896* allowed the movements of swine which appeared to be healthy, but it is clearly shown by clinical observation that apparently healthy pigs may be the subject of the disease, and to permit their movement is only adding fresh centres for infection.

This regulation was framed in the same year that a Departmental Committee of the Board of Agriculture published a report of its investigations, in which it spoke of swine fever being infectious and contagious, sometimes so acute as to kill in two days. But it further brought to light the fact that there was a slowly progressing obscure form of the disease, not attended by the ordinary symptoms, but equally infectious and contagious.

Ignorance of the condition which is probably now the

chief factor in keeping the disease alight, cannot, therefore, be claimed by the authorities responsible for the suppression of animal plagues.

The suppression and eradication of swine fever can be effected if the work be taken thoroughly in hand, and so long as its spontaneous origin is not entertained by those under whose authority regulations for its entire obliteration have to be issued.

What is required is the destruction of all affected and in-contacts, and the term in-contact must be understood to include every pig in the place. In this way whether the disease exists in an obvious or occult form it is got rid of, nothing must be spared.

All movements of swine, markets, fairs, etc., must be entirely stopped; the veterinary profession knows full well to what extent this is responsible for the spread of the disease.

The law allows the visibly healthy to live, but we have seen that animals may be affected which are not visibly diseased, and the sale of these produces fresh centres.

The chronic form of the disease where all the elements exist for the spread of the trouble, may frequently be recognised by the unthrifty condition of the animals, stunted growth, capricious appetite, intermittent diarrhoea, and inability to put on flesh.\* There is nothing to prevent these animals being kept alive, nor any regulation which prevents their subsequent sale as opportunity occurs.

Nothing short of Cattle Plague regulations can stamp out the disease, and this is the opinion of the greatest living authority on the contagious diseases of animals—Sir George Brown.†

Next in importance to the destruction of all pigs in the affected place is the complete restrictions of all movements of pigs in the area. There is evidence to show that cases have occurred where weeks have been known to elapse after the first outbreak, before the Board have declared it an

\* A. H. Berry, *op. cit.*

† McFadyean, *op. cit.*



infected area, during which time a score of fresh centres have developed.

As so much of the spread of the disease hinges on the question of swine movements, it is desirable to enter more fully into this question ; it is perhaps best to discuss the matter under two heads, viz., movements in an infected place and in an infected area.

Regarding movements in an infected place there must be none of any description ; no temporizing can be allowed ; if the disease exists all the swine must be destroyed, the place disinfected, and nothing in the shape of swine allowed in for six months.

Movements in the affected area should also be forbidden, in which case the country would soon be cleared of this pest, but since no Government is found strong enough to stop all movements, various temporizing measures have from time to time been adopted. One of these we have already examined, under the head of swine movements being permitted provided the swine were not visibly diseased. This as we have seen failed. The next temporizing measure is now on trial, it permits movements of swine provided they have been in the same ownership for twenty-eight days before movement, it being a condition of each movement that on arrival at their destination the swine are detained, and as far as possible kept isolated from other swine for a further period of twenty-eight days.

So much in these regulations depends upon the owner or person in charge keeping faith with the law ; experience goes to show that the object of most people is to evade the law, and there is nothing in the above regulations to prevent it. These restrictions are the best produced up to the present date, but will not get rid of swine fever, though if faithfully observed they should certainly reduce the number of outbreaks.

Nothing will get rid of the disease but destruction of affected and in-contacts, total prohibition of all movements, and rigorous disinfection.

The next important step is to destroy the infection on the

farm, and this from the habits of pigs is by no means as simple as it sounds. The poison is contained in the excreta of the diseased, it requires very little consideration to realize what this means where pigs have been permitted to roam about, or even when they have been confined to a sty. The poison may infect puddles or ponds, or carried about on the hands and boots of men employed on the farm, or in carts or nets used for conveying pigs, or in food, in fact, with every object, animate or inanimate, with which the animals may come in contact. How many farms are there systematically and thoroughly disinfected after swine fever, and how many are there capable of being thoroughly disinfected?

The entire prohibition of all movements of swine in the affected area prevents a man from restocking so long as the Order is in force; and this will bring about the destruction of the organisms.

The methods of disinfection have been dealt with elsewhere (p. 408), but we may here note that the best disinfectants for the destruction of the organism of swine fever are a 1-1,000 solution of perchloride of mercury, or 10 per cent. solution of chloride of lime.

The microbe of the disease is known to live for a long time outside the body. Experiments in America showed it could be kept alive in clear river water for from two to four months, while in stagnant pools it was still more dangerous. It has been determined experimentally that the organism can live from two to four months in the soil.\*

Apart from diseased pigs human beings and dogs are probably the next most active agents in the spread of the disease, and the disinfection of men as previously described for Cattle Plague and Foot and Mouth Disease should be rigidly enforced in swine fever, while dogs should either be tied up or shot. Those persons employed in attendance on the sick, butchers, and others brought in contact with the

\* Mr. A. Cope, *Annual Veterinary Report*, Board of Agriculture, 1902.

diseased, should be thoroughly disinfected, especially as regards their hands and boots.

While farm attendants and butchers are active means of spreading the disease from infected places, pig-dealers and castrators are no less responsible in carrying the disease about the country. These points must be fully realized, to prevent any source of leakage in the system of disinfection.

All fæces on the farm must be collected and destroyed by fire, and the ground disinfected from which they have been removed; all rubbing places must be disinfected, while the bedding and fæces in the sty are effectually destroyed by fire, and the place with its utensils, such as troughs, barrows, swill-tubs, buckets, etc., thoroughly dealt with.

The length of time that premises may remain infected where thorough disinfection is not practised seems to be considerable. It has been said that six months after the premises have been declared free, the disease has broken out through a manure heap being disturbed.\*

It appears quite certain that after thorough disinfection has been practised (including the entire destruction of the sty by fire), six months ought to elapse before fresh pigs are introduced.

That the present working of the law is gravely unsatisfactory, is patent to all veterinary surgeons who have to deal with this disease. The employment of laymen as inspectors, granting to police constables the power of issuing licences to move animals, and further the power they possess to alter the diagnosis in the face of professional evidence, would be amusing if it were not such a serious and costly matter to the State. A police officer may refuse to accept the opinion of the expert, and decline to notify the existence of the disease.

Even when notification has been made the machinery for declaring an infected area is slow to move, and weeks have been known to elapse before the proper restrictions are applied.

\* Mr. T. B. Blindloss, M.R.C.V.S., *Veterinary Record*, December 12, 1903.

All piggeries should be licensed, and their suitability for animals properly certified before a man is permitted to place animals in them. This should exist so long as Swine Fever is present in the country, for unsuitable premises cannot be properly disinfected.

Pig-dealers should be registered as is done in the county of Ayr; only men with suitable premises and who work under definite conditions are registered. Each consignment of pigs purchased by him has to be kept separate, also a register of swine purchased and sold, with their distribution. Such information is of the utmost value in tracking and controlling disease.

#### LEGISLATION.

*Diseases of Animals Act, 1894; Swine Fever Order of 1894; Markets and Fairs (Swine Fever) Order of 1896; Swine Fever Order of 1901; Swine Fever (Infected Areas) Order of 1902; Swine Fever (Regulation of Movements) Order of 1903; Swine Fever (Movement from Ireland) Order of 1904.*

Where swine fever exists, or has existed within twenty-eight days, the place shall be declared infected by an Inspector, notice served on the occupier of the premises, and to the usual authorities. The limits of an infected place may at any time be altered by the Board, and notice of such served on the occupier of the premises.

A place having been declared infected, swine whether sick or healthy cannot be moved into or out of it except by licence, and no others are permitted to come in contact. Carcasses of swine cannot be removed excepting by the written permission of the Inspector. No litter, manure, utensils, pens, hurdles, or other things can be removed from an infected place, except by written permission of an Inspector, and then not until properly disinfected.

No person (excepting the person tending the pig) can enter any infected place without the written authority of an Inspector. Everyone leaving an infected place (and this especially applies to the Inspector) shall wash his hands with soap and water, and disinfect his boots with carbolic or other disinfectant.

No person in charge of an affected or suspected pig, can tend any pig not so affected.

Under no circumstance can food, litter, or manure, be removed from an infected or suspected place without the licence of an Inspector.

An Inspector can require swine to be detained, and can serve a

special notice on the owner or person in charge, requiring that the swine be detained in whatever place is named, sty, farm, field, or elsewhere, until such notice be withdrawn in writing. During this time the same prohibition exists regarding movements as if the swine were actually diseased, viz., no movements of swine from or out of the place, no movements of any other swine into or out of such farm or place, and no swine permitted to come in contact with the swine detained.

When an Inspector takes action under this head, he at once reports not only to the local authority, but to the police officer in charge of the nearest police station of the district.

The carcass of a pig that at the time of *death* was affected or suspected of swine fever is directed to be buried in its skin freely slashed, at a depth of not less than six feet, and covered with quicklime or other disinfectant. Or the local authority may by licence permit the carcass after disinfection to be taken to a suitable place and destroyed by heat or chemicals. Burials or destructions cannot take place in the district of another authority without their permission.

There is nothing mentioned in this Order regarding the slaughter of affected or in-contact animals. We have to turn to the Act of 1894 to learn that the Board may slaughter and compensate if they think fit. Pigs *destroyed* by order of the Board under the Act of 1894 are dealt with by burial, sale, or otherwise.

An Inspector or officer of the Board may cause a sty or other place used for affected or suspected swine, and any utensil, hurdle, pen, or other thing used for or about such swine, and any woodwork with which they have come in contact, to be cleansed and disinfected to his satisfaction.

The same official may for the purpose of preventing the spread of swine fever cause any van, cart, or other vehicle used for carrying swine, and any rope, net, or other apparatus used in the conveyance of swine, to be cleansed and disinfected. An Inspector may cause any fodder, litter, or *fæces*, of affected or suspected cases, or that has been in contact with them, to be destroyed or disinfected. The owner or person in charge in all cases is to give reasonable facilities for the carrying out of this, and comply with any requirements.

Local authorities may require, with the view of preventing the spread of swine fever, the owner or occupier of any place used for the detention of swine prior to or subsequent to sale, to disinfect such place at his own expense; further they may insist on the cleansing and disinfection of vans, carts, ropes, nets, or other apparatus used for conveying swine, and this may be enforced without the animals being affected with the disease. If the person fails to carry this out, it can be done for him by the local authorities at his expense.

For preventing the introduction of disease into any district, local authorities may make such regulations as they think fit, for prohibiting

or regulating movements into their district from that of any other local authority in England, Wales, or Scotland.

The local authority may also make such regulations as they think fit for regulating or prohibiting the movements of swine within their district, giving the usual notice to railway companies. No Order of the local authority can authorize the movements into, within, or out of a swine fever infected area, or authorize the movements of swine which are affected.

Local authorities may, with the view of preventing the spread of disease, make such regulations as they deem fit for prohibiting or regulating the sale of swine within their district.

Pigs found in any public place, or during transit, to be affected with the disease are to be seized by the Inspector, together with in-contacts, removed to some convenient place for isolation, and await the orders of the Board.

If the owner requests slaughter the Inspector can give a licence for the purpose available for twelve hours, and shall specify where the destruction is to be effected.

The place where the swine have been seized can only be declared an infected place by the Board, but it is not to be used again until a Veterinary Inspector certifies it has been cleansed and disinfected.

Expenses connected with the seizure of animals and execution of this Order can be recovered from the owner.

Any place declared infected with swine fever remains so until the Order of the Board in writing declares it to be free.

An order known as the *Market and Fairs (Swine Fever) Order of 1896* applies only to such districts or part of districts as the Board shall define. Wherever it applies no local authority can permit a market, fair, sale, or exhibition of fat or store swine to take place in a district, excepting under the special condition which this Order defines.

A local authority may, if they are satisfied the proposed exhibition is a bonâ fide agricultural show, allow it to take place under licence provided it is not being held in a swine fever infected area, and they may authorize the sale of swine at such exhibition under such conditions as they think expedient.

In the same way, they may under licence permit the sale of fat or store swine, provided it does not occur in a swine fever infected area, and under the following special conditions :

1. That the sale is held on a farm or premises not in a swine fever infected place.
2. That no pig on the farm or premises is affected with swine fever.
3. That each pig has been on the farm or premises not less than 28 clear days.
4. That during that period no pig has been brought on to the

said farm or premises, and that no pig has been exposed to infection.

The licence must be signed by the local authority, who may impose such conditions as they think expedient, specifying the name and address of the person licensed to hold the sale, and specifying the premises where it is to be held.

The local authority may also licence a market, fair, or sale of fat swine only (but not in a swine fever infected area) under certain conditions :—

1. The swine shall be marked at the expense of the owner with a broad red line down the back, and another across the loins, to obliterate which is an offence against the Act.
2. Every pig exposed at such a market, fair, or sale, whether sold or not, must be slaughtered within four days.
3. Swine so exposed at a market, fair, or sale cannot be exposed at any other market, fair, or sale in Great Britain, and they can only be moved from the market, fair, or sale under certain provisions, viz., by means of a movement licence of the local authority, which licence only holds good for five days. The licence, besides specifying the person to whom it is granted, also describes the destination to which the swine are moved.

The licence accompanies the animals, and the swine while being moved for the purpose of slaughter are to be kept apart from all other swine. It is the duty of the local authority to see the swine are moved to the right place, and that their destruction is carried out within four days after the sale.

The licence for a market, fair, or sale shall be signed by the local authority, who shall give notice of the conditions on which it is held, the name and address of the person authorized to hold it, and the place where it is to be held ; further, a copy of the notice shall be kept posted in a prominent place during the sale. Such a licence may be revoked by the Board if considered expedient.

Periodical fairs, markets, or sales may be held on stated days for a time limit not exceeding one month, but capable of being renewed.

No local authority shall grant a licence for the above purpose unless the place where it is proposed to be held admits of being cleaned and disinfected. This process consists of the place being thoroughly swept, scraped, and dung, litter, or other matter effectually removed ; the parts are then to be thoroughly washed or scrubbed with water, and then disinfected as the local authority may direct. The sweepings and scrapings are to be mixed with quicklime, and effectually removed from contact with animals.

In addition to the above regulations, the Board reserves to itself the

right to grant by its own licence any market, fair, sale, or exhibition of fat or store swine, when after enquiry they consider exceptional circumstances render it necessary.

At all markets or fairs licensed under this Order, a veterinary inspector must attend, and 'fit persons' may be appointed by the local authority to attend for the purpose of granting movement licences.

At any sale licensed under the Order, the same 'fit person' appointed by the local authority may attend by request, and grant movement licences on behalf of the local authority.

It is an offence against the Act to—

1. Hold a market, fair, sale, etc., in contravention of this Order, or the condition of the licence.
2. For not marking, or for obliterating the mark on a pig sent for sale.
3. Moving a pig in contravention of the Order or movement licence.
4. Failing to slaughter a pig within the prescribed time.
5. Exposing for sale or exhibiting at any fair or sale in Great Britain a pig that has once been under licence and exposed for sale at a market or fair.
6. Failing to cleanse or disinfect any place used as a market, fair, or sale-yard.

It will be observed that in this Order the object is to regulate sales, markets, and fairs in a district which is not a swine fever infected area.

In the following Order, known as the *Swine Fever (Infected Areas) Order of 1902*, the object is to regulate movements in an infected area consistent with safety.

A local authority may permit under licence the movement of swine along, over, or across, a highway or thoroughfare in an infected area, but not in an infected place.

Without such licence it is illegal to move swine as above, even in a vehicle or not.

A licence only lasts four days, and can only be granted if the proposed movement is necessary or expedient; the swine are then to be moved by the nearest available route and without delay.

A licence for breeding purposes may also be granted under the same restrictions and with power to return, provided that the premises to be visited are not outside an infected area.

A licence may be granted for the movement of swine from a station, wharf, or other premises in an infected area to premises in an infected area, but without any movement along, across, or over a highway or thoroughfare. They may also be moved under licence from a non-infected area into an infected area.

On the completion of movement of all swine under this Order, the



licence is to be delivered or sent by post forthwith to the nearest police-station by the person in charge. Neglect of this is an offence against the Act.

A market, sale, or fair may be held in an infected area under certain conditions, viz., the swine must have been on the premises 28 days, and no pig whether for breeding or not must have been brought on to the premises during that period. The swine to be sold must not be affected with swine fever, nor have been exposed to infection during the above 28 days. No sale can be held in a swine fever infected place.

No swine in an infected area are permitted to stray on a highway or thoroughfare. This constitutes an offence against the Act.

Swine landed from Ireland at a port in an infected area may be moved through that area free from any restrictions.

The *Swine Fever Order of 1901* deals almost exclusively with the question of disinfection. So far as the cleansing of places used for temporary detention of swine prior to sale is concerned, much the same regulations exist as are noted under the *Swine Fever Order of 1894*, excepting that the occupier of such place must clean and disinfect it at his own expense every seven days, if the place has been used for swine during that period, and also at any time forthwith on receipt of a notice by an Inspector of the Board or local authority; but such cleaning and disinfecting only applies to those parts with which the pig and its excreta have come in contact. The coating of the parts with lime-wash after the preliminary scrubbing is the only new feature in the process of disinfection.

Under this Order the premises of a pig-dealer are included in compulsory disinfection, also the vehicles used by pig-dealers. The floor and other parts of such vehicles are to be cleaned by scraping, scrubbing with water, and application of lime-wash, or a solution of carbolic acid applied. The scrapings, excreta, etc., being well mixed with quicklime and 'effectually removed from contact with swine.' This disinfection of pig-dealers' vehicles is to take place as soon as practicable after use, and before being again used, and at any other time forthwith on receipt of a notice from an Inspector.

Crates, hampers, boxes, nets, ropes, and other things used by a pig-dealer for the conveyance of swine, shall be similarly dealt with.

If any person fails to cleanse and disinfect any place, vehicle, crate, rope, etc., as directed, it can be done by the local authorities at his expense, and the owner or occupier is bound to give reasonable facilities for carrying it out.

This order defines a 'pig-dealer' as a person habitually engaged in the trade or business of selling swine (other than swine bred by him), but does not include a person who as auctioneer sells swine the property of others.

Strange to say, none of the special Orders devoted to swine fever make any mention of destruction or compensation. For this the Act of 1894 has to be referred to, where it is laid down that the Board of Agriculture may, if they think fit in any case, order any swine affected with or suspected of swine fever to be destroyed, and they can do the same to any in-contacts.

The compensation given for affected cases is one half the value of the animal before it became affected, and for any others their value before slaughter.

The cost of this falls on the Pleuro-pneumonia Account for Great Britain.

*Swine Fever (Regulation of Movements) Order of 1903.*—This Order deals with movement of swine from outside a scheduled into a scheduled area; or to movements between two scheduled areas. The Order does not authorize movements of swine either in a swine-fever infected place, or a swine fever infected area.

A scheduled area is defined as one to which a subsequent Order of the Board directs the above provisions to be applied.

Swine may be moved from premises outside a scheduled area to premises in a scheduled area, if licensed by the authority of the district in which the place of destination exists.

A licence for this movement is granted to the owner or his agent, but only if the swine have been on the premises from which they are to be moved for twenty-eight days previously, and that during this time they have not been exposed to infection.

This declaration must be countersigned by a police officer of the district where the swine are, and the licence only remains in force six days.

If the swine so moved are not intended for slaughter, they must not be moved from the place of destination for twenty-eight days after arrival, during which time they are to be kept separate from other swine.

If they are moved into a scheduled area for a market, fair, sale-yard, or exhibition, they can only be moved under licence from such place, to a bacon factory or slaughter-house, where they shall be detained until slaughtered.

Swine may be moved by licence from outside a scheduled area direct to a bacon factory or slaughter-house in a scheduled area, or to any market, lairs, or sale-yard in a scheduled area, provided they are intended for immediate slaughter. Under these conditions they must be marked on the back with a red cross, not less than nine inches long; they must as far as practicable be moved by rail.

If they have previously proceeded to a lair, market, or sale-yard, they can be moved therefrom by licence, but only to a bacon factory or slaughter-house.

Any lairs, market, or sale-yard, used for this purpose must, before being again used, be cleansed in the usual manner by the person in occupation, or the local authority.

*Swine Fever (Movement from Ireland) Order of 1904.*—This directs that swine brought from Ireland to Great Britain can only be landed for immediate slaughter, and under definite conditions. They must be licensed to be landed and moved to the place of destination by the Department of Agriculture in Ireland. Swine so landed are to be indelibly marked on the back in the usual way; they are to be moved as far as practicable by rail to the place of destination, and under all circumstances must move by the nearest available route, and without unnecessary delay. Further, they must not during such movement come in contact with swine not so marked.

The destination may be a bacon factory, slaughter-house, lair, market, or sale-yard. From the three latter they can be moved, but only under the licence of the local authority, to a specified bacon factory or slaughter-house, where they are detained until destroyed.

Should any other swine be moved into a lair, market, or sale-yard while such premises are being used for the Irish swine, they at once become subject to this Order.

Lairs, markets, and sale-yards shall, as soon as practicable after use, and before being again used, be cleaned and disinfected by scraping, sweeping, and sprinkling with lime-wash containing 5 per cent. carbolic acid. The same applies to all pens, hurdles, and fittings.

The responsibility for the cleansing and disinfection of the lair, market, or sale-yard lies with the person in occupation, and in any other case with the local authority of the district.

#### SWINE ERYSIPELAS.

This disease has been confused with swine fever. McFadyean\* tells us it is not a prevalent affection in Great Britain, though common in Denmark, France, and Germany; he further gives the distinguishing features between it and swine fever.

In France, Germany, and other Continental States it is said to be a highly contagious and infectious disease, and appears to be more acute and fatal than swine fever, with a mortality of 80 per cent. In cases not proving fatal in a

\* *Journal of the Royal Agricultural Society*, vol. iv., 1893.

few days, recovery is prompt and complete, but a small proportion of the cases become unthrifty and die suddenly a few weeks later from verrucose endocarditis; the vegetations on the valves contain the organism of the disease.\*

The disease though not very prevalent is perfectly well known in Great Britain; it is not included under the Diseases of Animals Act. Outbreaks can be dealt with on ordinary hygienic principles, viz., the separation of the sick from the healthy, and thorough disinfection of the affected surroundings on the lines laid down for swine fever; while the healthy may be immunized by any of the following methods:

1. Pasteur's method, which consists of inoculation with a vaccine that has been passed through rabbits, and a second vaccination twelve days later with a vaccine passed through pigeons and subsequently cultivated in broth.

2. Lorenz's method of simultaneous inoculation with serum in the region of one ear, and a culture of the virus into the same region on the opposite side.

3. Leclainche's method, whereby the serum and culture are mixed at the time of inoculation, and after an interval of twelve days an inoculation with a pure culture made.

#### SWINE PLAGUE.

This disease is only noticed here as it has been confused with swine fever. It appears to be very prevalent in Germany and some other Continental countries, but as a contagious disease of swine it is unknown in Great Britain. The disease is caused by a small bacterium, and its most constant lesion is pneumonia.

#### GLANDERS.

The animal plagues discussed in previous sections are remarkable for their highly infective nature, and the rapidity with which they spread over a large area, and

\* Report of Swine Fever Committee, *idem*, vol. viii., 1897.

affect thousands of animals. But this is by no means the history of all infectious diseases, of which the one now under consideration is a good example. Known in Europe from time immemorial it has never, excepting when large bodies of horses are brought together, as in armies in the field, caused what could be accurately described as enormous losses.\*

The virus does not run like wild-fire over a country like Rinderpest and Foot and Mouth Disease; infection is a slow process, and even where neglected it does not run through a stable like Influenza, or suddenly infect large bodies of animals as Cattle Plague does.

It is, in fact, more than likely that the majority of horses possess a certain degree of immunity to its attack, otherwise considering the state of legislation on the subject, and the hundreds of years the disease must have existed in this country, it is difficult to understand why there are any horses left.

This feature of glanders is in a sense unfortunate; it explains why until within quite recent times men of experience were to be found who regarded other causes than contagion as a means of spread, and this has up to the present proved the greatest stumbling-block to effective legislation. As we have seen earlier in this chapter, it is not until a disease threatens to decimate the country, that the natural apathy and conservative character of our people are cast aside. Glanders has never shown any sign of decimating our horses; it has among large collections of horses committed havoc, but has given no indication of clearing off the stock in the country, and in consequence arouses no popular feeling.

The only real feeling which exists is in the veterinary profession, which year by year sees a number of horses destroyed for a disease which is capable of being stamped out, and, further, knows of its existence in other living

\* The monetary losses on the other hand are very heavy. W. Hunting calculates that the loss from glanders in the United Kingdom for the 21 years 1881-1901 amounts to £713,000.

centres of infection, but is powerless to act through the unsatisfactory state of the law.

We have said it is due to the comparatively quiet behaviour of glanders that no popular feeling exists for its suppression, though one would have thought that the fact of it being communicable to man would have aroused some instinct of humanity; but as the recorded deaths in the human subject from a most loathsome disease only number about half a dozen a year, we cannot expect this to seriously weigh with a race singularly unsentimental.

In the case of Rabies it only became a strong argument when the deaths among humans numbered some scores annually, and a genuine feeling of alarm for *personal* safety was felt; no such feeling will ever exist regarding glanders, as horses and stables are an unknown quantity to the vast majority of people.

If effective legislation ever becomes possible, it will only be through the agitation of the horse-owning public; it would then require a very powerful administration to vote public money for the suppression of a disease, the effects of which are only felt by a minute fraction of the community, and, further, an affection which causes no inconvenience or immediate loss to anyone but the owner.

Yet all these are arguments in favour of effective legislation; the mere fact that the vast majority of the public can never have their pockets touched by the existence of glanders in the kingdom, is no reason why the State should not take the matter in hand. As a matter of fact it does deal effectively with the question so far as its own property is concerned, and there is no reason why it should allow contagion to exist as a menace, either to its own horses or those of the public, if legislation can control it.

There is always another side to the question: the State expects the public to take an interest in the care and preservation of its own property, and deprecates paternal legislation; up to a certain point the view is this right one, and was the basis of our national progress in the past.

It possibly argues that in business horses are not kept to

look at, but are a source of income, and if an owner gets a disease like glanders into his stud it is his duty to get rid of it, just as he would, for instance, have to do if the disease were influenza; and from the point of view of a guardian of the public purse this aspect is natural enough.

What the lay mind in these questions is unable to grasp, is that if a disease is to be eradicated it cannot be left to individual efforts, for the reason that a definite programme is required applicable to all and everyone, without which 'A' may at some cost free himself from disease, and yet get infected again from his neighbour 'B,' who has made little or no attempt, and has sacrificed nothing.

Uniform action must be observed, definite rules laid down by which all have to abide whether anxious or no, and this is where the small owner is severely hit, for in the disease under consideration to destroy without compensation three horses out of his four, or perhaps the lot, may simply bring him face to face with the bankrupt court. This question will be reconsidered later.

The general features of glanders are well known. It is a disease of cities and not of the country; its centre is London from which it spreads into the neighbouring counties. If, as Hunting has done in his tables,\* the cases occurring in London and the surrounding counties be added together, they are found to represent 90 per cent. of the total number of cases in England.

These figures, extracted from the Government Returns, are an excellent object-lesson, there is no doubt where legislation should begin, and the influence of overcrowding is well shown.

Glanders is said to be slowly but surely increasing; the following chart from Hunting shows the annual fluctuations of Glanders for 23 years in Great Britain, the curve is irregular, and it is not always clear why it should be. Hunting explains the 1881 and 1892 figures by the prevalence of influenza, but this does not help to clear up the

\* 'Glanders': Mr. W. Hunting, F.R.C.V.S., *Proceedings of the National Veterinary Association*, 1902.

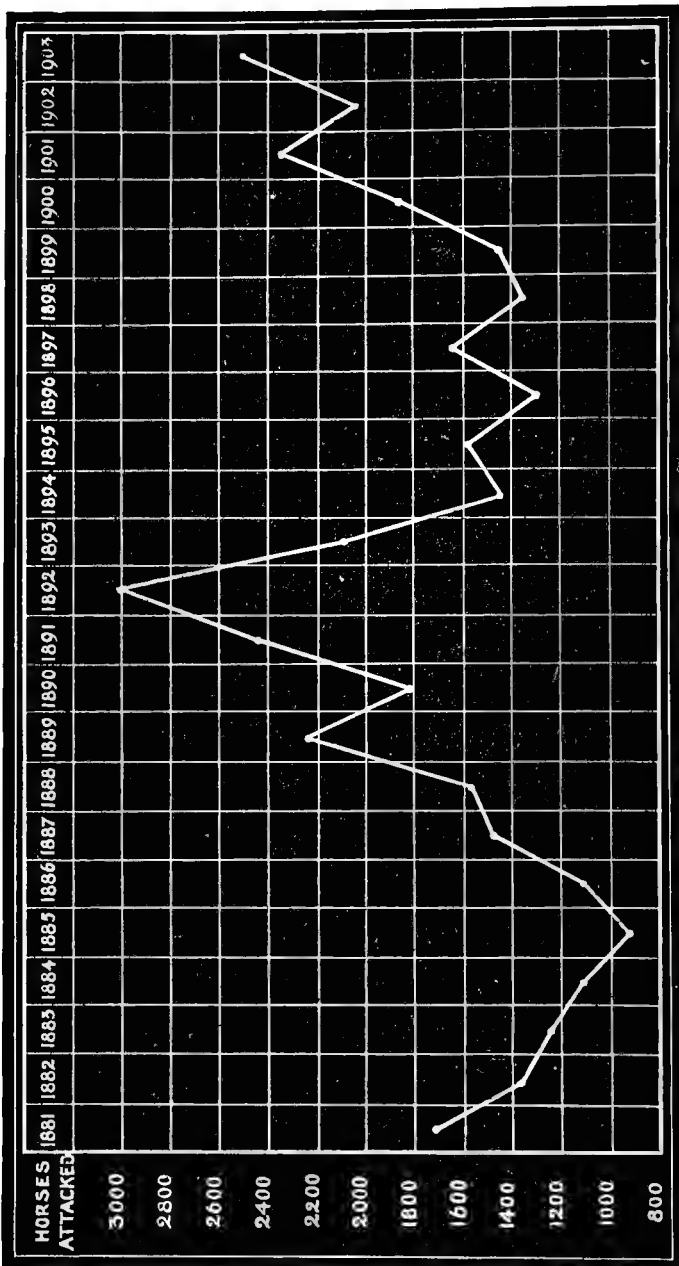

Fig. 188.—Chart showing the yearly fluctuations and the total number of reported cases of Glanders in Great Britain, 1881-1903.



1900 and 1901 rise, which is probably due, as he suggests, to the greater movements of horses due to the war in South Africa.

Though there is considerable evidence that glanders is on the increase, the only real evidence on this point is not available, viz., the percentage of cases on the total number of horses in the country. There is no census taken, which in a country that prides itself on its production of horses is a remarkable anomaly. It is impossible, therefore, to employ this test of increase, for it is conceivable it might turn out to be more apparent than real, viz., due to a larger number of animals in the country.

There are fluctuations observable month by month in the number of horses attacked. Hunting's tables show the largest amount of disease is met with from July to October, and the least from February to April; the explanation he offers of this fact is no doubt the right one, viz., that the hot months are the most exhaustive of the year, and they hasten the development of the disease which is already latent in the lungs.

The contagion of glanders enters the system either by the air-passages or by the digestive tract. The fact of a healthy horse being in the same atmosphere as a glandered one does not necessarily mean infection. The bacillus of the disease must be inhaled, and such is obtained from the desiccation of the nasal discharge. This source of infection is denied by Hunting, but it appears to us that what holds good for the spread of tuberculosis in this respect is also applicable to glanders. The dried sputum of tubercle and the dried nasal discharge of glanders are both capable of infecting, though we at once admit that this unlike tuberculosis is not the common cause of infection.

Hunting's argument that floating germs in the air are not a source of infection, is based on the fact that if this were so it would be impossible to explain the escape of horsekeepers passing twelve hours a day in infected stables. But there is another side to this question, and that is the relative immunity of man to glanders.

Glanders was most prevalent during the war in South Africa. Clinical cases were picked out by thousands, yet we never heard of a man, either white or black, being affected, though the risk of infection was greater than could ever occur in civil life.

We do not consider that Hunting's argument on this point is a very strong one, though we fully admit aërial infection can never occupy the same position as infection through the digestive canal.

It is beyond all shadow of doubt that if the discharge from a glandered horse be introduced into the stomach of a healthy one infection results. This discharge may find its way in by food, or from nose-bags, mangers, pails, water-troughs, in fact anything connected with food or feeding on to which the discharge may fall. The nostrils and mouth are such a short distance apart, that in the act of feeding, the poison must of necessity find its way into mangers and surrounding parts, and healthy horses fed from the same place or same nose-bag run the gravest risk. Hunting is therefore right to insist on infection by the digestive canal.

Infection by contact is only possible if the virus be introduced under the skin, or if after being placed on the unbroken skin it finally finds its way into the mouth. Take, for example, a glandered horse in a field, he can infect his companions either through the grass he has soiled with the nasal discharge during grazing, or from discharge he has left on the bodies of the other horses during their period of companionship; say, for instance, this discharge is left on the sides, it may easily be ingested through the horse biting himself either as the result of fly or skin irritation.

Hunting does not regard the public water-trough as a serious source of danger, though he admits the open trough in a stable yard at which glandered horses drink is a fertile cause of the spread of the disease. The position therefore appears to be this, that the number of glandered horses watered at a public trough is very small, and the risk appears to be worth running, in the face of the greater

danger which would result in hot weather from closing the troughs.

This is a very important point in legislating against the disease, and unless supported by the weight of Mr. Hunting's authority and observation, we should certainly have taken the other view, for the organism of the disease can remain virulent in water for many days. It is quite possible the comparative immunity enjoyed by horses watering at a public trough, is due to the fact that a man driving a horse with a nasal discharge, or one he believes to be glandered, does not water it at a public trough to avoid the risk of detection.

This observation might suggest a better knowledge of glanders on the part of carmen and drivers than they actually possess. They know it is a disease associated with a discharge from the nose, and if a case has occurred previously in the stud it is reasonable they should regard a horse with a nasal discharge with some degree of suspicion. We offer this as a possible explanation of the fact asserted by Hunting, of the rarity with which glanders is contracted at the public water-trough, though in this matter it is fair to say there are London practitioners who do not agree with him.

The length of time which elapses between infection and clinical signs of the disease is most variable; months, sometimes many months, pass after infection before there are visible signs of the disease.

The term clinical or visible signs of disease is of the utmost importance. No one suggests that the virus lies for months in the intestinal canal, and suddenly breaks out in the lungs and nostrils; but it may lie for months in the lungs without giving any external indication, and there is no doubt whatever that the risk of horses spreading glanders when there is no clinical sign of disease is very slight; indeed Hunting does not admit there is any risk even if the lungs be 'studded with nodules,' but admits the danger of the existence of such an animal, as local lesions may develop very suddenly.

The practical bearing of this question on the curability of glanders is very great, and the observation is of the utmost value in military life, as a horse in good condition which reacts to mallein, but with no local lesions may safely be worked during war time without the least risk to its fellows, and may possibly be dead from other trouble long before any local lesions have developed.

Turning once more to the question of incubation, experiments made by giving animals the virus mixed with their food, have been followed by clinical evidence of the disease in from one to three months. But the length of incubation depends upon the method of inoculation; it is much shorter if the virus finds its way into a cut in the skin, and it is very much shorter in a poor and debilitated animal than in one in good condition; or in one out of health from sickness or injury than in one not so suffering.

This fact in the pre-mallein days was constantly taken advantage of as a method of diagnosis; a liberal dose of aloes brought out the local indications either in the nostril or on the surface of the body.

It has not been felt necessary in this section to make special reference to farcy, as for our purpose the two diseases are identical.

*Mallein.*—In days now happily gone by, one of the very greatest difficulties in getting rid of glanders was the doubt attendant on its diagnosis. No difficulty ever existed with the obviously diseased, but when clearing out a stud we require more than the obvious cases, we want all the latent ones as well, and the difficulty and want of exactitude in determining these in the past are still fresh in our memories. Apart from the difficulty was the question of delay; for weeks and months we were kept in a state of expectation, doubt and uncertainty.

Thanks to mallein\* the whole of this has changed as completely as if the wand of a magician had been passed

\* It ought to have been called Kalning. In a few years the Russian Veterinary Surgeon who discovered it, and subsequently lost his life from glanders will be forgotten.

over it, there is no longer any painful uncertainty, hesitation, prolonged doubt, serious errors in diagnosis, or any of the difficulties of the pre-mallein days. With a certainty, which for practical purposes is complete, glanders can be picked out, and, moreover, with astounding rapidity. It is now only a matter of a few hours, whereas before it was months.

In mallein we have an agent of immense power in skilful hands; it is a chemical substance obtained from the glanders organism, which on injection into a glandered horse gives rise to a swelling and rise of body temperature, but in a non-glandered one has no effect. The rise in temperature and the swelling constitute a reaction, in this case a double reaction, but we may often have to depend upon the swelling alone, viz., a single reaction.

It is only from its hygienic aspect that we can consider mallein, the stamping out of glanders cannot take place without it, and no consideration of the stamping-out question can be made which does not refer to the use of mallein.

Mallein is a simple chemical agent in skilled hands, but a very dangerous substance in the unskilled; dangerous, not because it threatens life, but because its effects may be wrongly interpreted and lead to disaster. The questions of judgment and experience are inseparable from mallein operations.

If the rise in temperature is of so much importance, it is clear the body temperature of those for testing must be ascertained beforehand, and none subjected to the test which are not normal.

Nothing but practical experience can teach what amount of swelling is permissible consistent with perfect freedom from disease, and the character and nature of a swelling which indicates a glandered from a non-glandered animal.

All this is the duty of another section of our science to teach; it is alluded to here as the public either refuse to admit the value of mallein, or go to the other extreme and regard it as a test which can be applied by anyone. This

of course is not so, the personal equation is a most important matter, and consistently true results are only obtained when the man behind the syringe is as much up to standard as his mallein.

It is undeniable that greater accuracy is obtained from the double than with the single reaction, but if we had to elect on which single test the greatest reliance could be placed, without hesitation we should accept the local reaction. With temperature and local reaction no errors should arise.

The body temperature should be taken four times the day before inoculation, and four times during the 12 hours preceding inoculation. If the latter is made towards evening, say 8 p.m., the temperature for that day should begin to be taken at 8 a.m., and every four hours up to 8 p.m., when the injection is made.

Twelve hours after inoculation, viz., 8 a.m. next day, the temperature is again taken, and again at the 16th, 20th, and 24th hour; by this time in the majority of cases a definite opinion can be formed; though cases of delayed reaction, even up to the 48th hour, are not uncommon, and should always be looked for.

Animals living in the open, especially when there are great variations of temperature, or very hot days, are best tested by local reaction only, as the thermometer is likely to mislead. In these cases a valuable aid in a doubtful swelling is lost, but it is unavoidable. A doubtful swelling is a moderately large one with thin edges, dropsical, and scarcely if at all painful. It is doubtful because it is large, and in such a case the thermometer readings would be invaluable. An undoubted swelling is large with thickened raised edges, and painful, often extremely so. We need not in the least mind what the temperature is of an animal presenting this local reaction, as such a horse is glandered beyond all doubt.

In doubtful reactions it is well to wait for three or four weeks before repeating the test, but under the exigencies of military service inoculations have frequently to be repeated

without any delay, and are found quite satisfactory. In such cases double doses are often employed, and in all cases of primary testing of mules double doses are best.

The question of double doses need not detain us long; for some time past we have used such in all doubtful cases, and invariably in the case of testing mules, as it has been found from experience that there is sometimes a difficulty in getting a mule to react even when clinically glandered. We have observed the same with a few horses, and have in one or two cases had to employ a triple dose in order to obtain a local reaction.

It is always desirable to measure the size of the reaction obtained in mallein testing, by means of a tape measure in both its diameters, and the measurement should be taken at the 16th, 20th, and 24th hours. This is particularly valuable where local reactions alone are being observed. A useful aid is to clip a mark on the neck where the needle is inserted, and clip the hair around the region of the swelling at each period of observation. It is a marking soon made, and is very helpful where a large number of animals are being tested.

By repeated injections of mallein a tolerance is established, and finally no reaction obtained in an animal which has previously given an undoubted glanders reaction. This failure to react may either mean that the case is cured, or that a tolerance is obtained though the disease is still active in the lungs. The question is a purely pathological one, but is mentioned here, as a tolerance to mallein is not without its hygienic aspect.

The suppression of glanders is an expensive but certain process, far too expensive perhaps for the private individual, or especially small owner, to attempt without outside aid, but absolutely certain in its results.

With mallein and a free hand one can undertake with a light heart the extinction of glanders in an army, let alone in a large stud; but the difficulty is to get people to make the needful sacrifices in order to effect the desired end, and a policy of compromise has often to be adopted.

The history of glanders legislation is unsatisfactory, for which the Government cannot be held wholly responsible, as it is only within comparatively recent years that the pernicious doctrine of spontaneous generation has been weeded out of the profession. Logically it would be an impossibility for a Government to attempt the eradication of a disease which might arise spontaneously at any time!

But certainly within the last fifteen years, there is no reason why better measures should not have been devised to meet a disease which appears to be steadily on the increase.

Fortunately the previous blots in legislation of regarding glanders and farcy as distinct diseases no longer exist. The law now accepts the veterinary opinion of a century old that the diseases are identical, and thus paves the way towards eradication, but the weak spot in the machinery is permissive legislation. It is local authorities by whom regulations 'may' be made to control movements of animals, or who 'may' make such regulations for cleansing and disinfecting as they shall deem fit, or 'may, if they think fit,' cause a glandered animal to be destroyed; and finally, give compensation out of the local rates of such sum as they shall 'think expedient.'

It is indeed no wonder that such legislation has led for some years past to the active criticism of the profession\* which recognises the futility of attempting to deal with a disease like glanders without central control, or by depending entirely on permissive legislation, and the varying intelligence of a score of local authorities. Mr. Hunting is right in insisting on this being an Central and not a local question.

*Compensation.*—The vexed question of compensation we approach with great diffidence. Glanders cannot either in its destructive effects or the rapidity of its spread, for one moment compare with such diseases as cattle plague, foot

\* The name of Mr. W. Hunting, F.R.C.V.S., should be inseparably connected with the suppression of glanders, as completely as is that of Gamgee's with the eradication of cattle plague.



and mouth disease, pleuro-pneumonia or swine fever, all of which are plagues in which compensation has been given. It has never assumed proportions of national importance, and the question of compensation has to be considered from this aspect. On the other hand the existence of the disease is a menace to the horse-owning community, who have a right to seek protection and demand the eradication of the disease.

Compensation may be regarded in two lights, first as an honest attempt to help the owner, especially the small owner, out of his difficulties, and secondly, as a reward for not concealing disease. It is only in the former light that we shall consider the question, and the important point is What claim has a horse owner on the public purse when he gets glanders in his stud? Personally speaking we think he has very little. If he keeps horses for pleasure he can afford the loss by disease, but practically we know this is not the class of horse that suffers from glanders, it is almost essentially a disease of the working and not the pleasure horse. This being so, no man keeps a horse unless he is making money by so doing, and it is a reasonable thing to think if the horse is a source of profit the owner might, like a prudent man, insure himself against disease, and not have to appeal to the public for help when in difficulties. We are naturally an improvident race, and improvidence is only another name for selfishness; it is doubtful how far this selfishness should be compensated for by assistance from the public purse.

At present an owner does or does not get compensation or glanders, depending on the caprice of the local authorities; some may be liberal and allow five pounds a head, others give the price of a dead horse, others nothing whatever. This is one of the many disadvantages of permissive legislation.

The amount of compensation fixed by law is 'such sum as the local authority think expedient,' being a minimum of two pounds and never to exceed one-fourth the value of the animal in health. All compensation can be avoided by

a local authority not insisting on the destruction of the diseased animals, but by closing the premises, they thus compel the owner to carry it out. Compensation out of the local rates can only be claimed when the authorities *think fit* with the consent of the owner, to cause the diseased animal to be destroyed. All this of course is utterly bad legislation and defeats its object.

Compensation if given must be Imperial, and not taken out of local rates. One quarter the value of the animal in health is too little, if compensation is necessary it should be one half. Compensation should only be given for animals not clinically diseased.

McFadyean has estimated that compensation on the basis of half value, viz., £20, would cost the State £400,000 in the first year, and £100,000 in the second year, an expenditure that no Chancellor of the Exchequer could regard with a light heart.

It seems quite fair to expect from horse owners a certain amount of self-help. Why, for instance, do they not insure their horses against loss, in which case they would only have to look to the State for good and effective laws and not for money?

It should be possible until glanders is exterminated to place a tax on all horses, and use the money thus obtained for the purpose of getting rid of the disease. In this way the tax and the benefits would be solely confined to the horse-owning public, and not fall on the ratepayer who feels completely indifferent whether glanders exists or not, so long as it does not affect his food bill. Such legislation as this should be regarded in the light of an insurance and not a taxation.

If horse owners are seriously anxious to get rid of this disease a determined attempt at self-help might meet with State assistance, especially in the case of the smaller proprietors. But anxious as we are to see the disease extinguished, it is only fair to the Imperial purse that some indication should be given by owners of a real desire to get rid of glanders, and this should be shown not only by

means of insurance, but by improving the sanitary conditions under which horses live and work.

Where the law should step in with no uncertain voice is in its regulations for controlling the spread of the disease ; it only legislates for animals visibly glandered, yet it cannot be ignorant of the fact that it is now possible to determine whether any other horses in the stud are affected, though not visibly glandered. These in time become clinical cases, cause further infection before being recognised, and so the disease hangs to the place month by month and year by year. Frequently the owner gets alarmed, and takes an opportunity of selling off his infected stud. This the law cannot prevent, although it is within its knowledge that a visibly glandered horse has, perhaps, quite recently been destroyed in this stable.

It is here we consider the law is particularly weak ; rigid regulations exist regarding notification of the affected, movements and isolation, but nothing is done to deal with the smouldering elements left alive in the stud, though to pick them out is a matter of simplicity. In other words, the law contents itself with the visibly diseased only, and takes no notice of the others ; it attempts to control the disease but not to stamp it out.

To effect this latter the law should insist on the whole stud of horses being malleined on the existence of a case of the disease, and all that react should be ear-marked. If the State is not prepared to pay compensation it cannot insist on the ' reactors ' being destroyed, but it should insist on periodical inspections, so that animals may, at the earliest possible opportunity, be picked out as they become visibly affected.

There are many animals which react to mallein with months', perhaps a year or two's, work left in them, and though if we wished to eradicate the disease the right thing to do in the present state of our knowledge is to destroy them, yet the proceeding is so costly as to be prohibitive. For such animals the only scheme is isolation, to be kept, fed, watered, and worked by themselves, until the almost

inevitable occurs, but we realize the difficulties, expense, inconvenience, and utter inability to successfully carry it out unless the owners are willing and anxious to assist, and the latter is hardly to be looked for in a scheme which is a charge, perhaps a heavy one, against the proprietor.

The above method of dealing with 'reactors' was suggested by the Departmental Committee on Glanders of 1899, and presumably it knew of the practicability of the scheme it recommended, in fact it is known to be the plan on which certain infected studs have been successfully dealt with, though it would present perhaps great difficulties to the small owner.

By the regular malleining of such an isolated stud it might be possible in several cases to effect a cure, while the clinical cases could be picked out at the periodical inspections.

Such a scheme as the one put forward provides against the further infection of the healthy stock, but it is obviously weak in some essential points of which the most fallible is the personal equation.

Isolation is a difficult matter unless two distinct buildings are obtainable; without this the sources of leakage from indifference and neglect will be very great, and the object possibly defeated.

*Eradication.*—On an outbreak of glanders occurring, the first thing to do is the selection of all clinical cases by inspection. For this latter purpose the nasal chambers must be illuminated by means of a mirror, without which no thorough inspection is possible. On dark days an electric lamp should be so arranged as to have its light reflected up the nose.

After the destruction of all clinically affected, the stud should be arranged in batches for mallein testing, but it is a sound precautionary measure not to mallein at once, but rather to wait for a month, so as to prevent the most recently infected cases escaping observation by failing to react. It is obvious that a horse infected two or three days

previously will not react to mallein, but may three or four weeks later.

While this period of waiting is occurring, all suspects and in-contacts may be malleined and disposed of, those failing to react may come up again when the period for general malleining arrives. Disinfection should also be carried out.

On the expiration of the needful time the whole stud may be malleined in batches, the size of which must entirely depend upon the available assistance for taking temperatures.

The disinfection to be practised must be thorough; walls, woodwork, mangers, buckets, fittings of all descriptions must be dealt with in accordance with the principles laid down in the chapter on disinfection, especial attention being paid to the mangers, walls above them, stall partitions and flooring.

The prevention of the introduction of further infection can be brought about by the use of mallein. All horses a month after purchase should be malleined, and in the meantime kept in a stable by themselves.

It may be necessary to mallein a stud two or more times to insure its freedom from disease. Recently infected cases may not be detected at the first or even second testing. As a tolerance to mallein is obtained by repeated injections, it is advisable to allow a month to elapse between each re-testing.

#### LEGISLATION.

*Diseases of Animals Act, 1894; Glanders or Farcy Order of 1894.*

The Order defines glanders and farcy as identical, and brings horses, asses, and mules, under the Act.

The notification of the disease falls on the person having, or having had in his possession, or under his charge, any animal so diseased. The Inspector is to act at once and discharge the powers and duties conferred on him, on receiving in any manner whatsoever information of the supposed existence of the disease.

Any local authority may make such Regulations as they think fit for the following purposes :

- (a) To prohibit or regulate the movement of any diseased or suspected equines, either into, in, or out of an affected or suspected place. They may also make what regulations they like regarding the marking for distinguishing purposes of such animals.
- (b) Regulations to prohibit or regulate the movement into or out of any place where the disease exists, of any equine which has been in the infected place, or in contact with the diseased or suspected animal, or otherwise exposed to infection.
- (c) And regulations bearing on the removal of fodder, litter, etc., from any place which has been in contact with, or used for diseased or suspected animals.

Regulation *b* can only be enforced so long as there remains an actually diseased animal in the affected place, and until the place has been cleansed and disinfected by the owner or occupier of the premises.

The power given under this Order to a local authority, is that they may shut up a man's stable until he disposes of his affected horses, and disinfects the place; further they may placard the place, notify the existence of disease, and continue this until the horse dies or is destroyed, and until the place is disinfected.

The chief object of these regulations apparently, is to bring pressure to bear on the owner or occupier to take action.

Local authorities may also make such regulations as they think fit for the purpose of cleansing and disinfection. This comprises the cleaning and disinfection of the place used by diseased or suspected animals, and of all utensils, fittings, mangers, etc., used for them. The disinfection and cleansing of any vehicle used for the conveyance of a diseased or suspected animal, excepting railway trucks. Local authorities may prescribe the method by which the cleansing and disinfection are to be effected, and further, they have the power to determine whether the expense of such cleansing and disinfection shall fall on the local authorities, or on the owner, lessee, or occupier.

If the owner, occupier, or lessee, refuses to do the needful cleansing and disinfection, it can be done at his expense by the local authority, and under any circumstances the responsible person is compelled to give all reasonable facilities for the work being carried out.

It is an offence for any person to expose a diseased or suspected animal in any public or private place where horses are usually sold; or in such place for any person to place a diseased or suspected animal near to the healthy.

No diseased or suspected animal can be sent by rail, boat, or ship, nor can it be carried, led, or driven on a highway or thoroughfare.

No diseased or suspected animal can be placed on common land, or in any field or place insufficiently fenced.

No diseased or suspected animal is allowed either to graze or to stray on a highway.

Under any of the above circumstances where these rules are contravened, the animal may be seized, examined by a Veterinary Inspector, and dealt with as follows :

If diseased it is forthwith destroyed in the presence of the Inspector, at such place as he may fix.

If the case is only suspicious, it may be destroyed on the spot at the request of the owner or person in charge ; or it may be moved under the licence of an Inspector to a suitable place, and then destroyed within twelve hours, for which period only the licence is available.

The licence specifies where the destruction is to be carried out, and it cannot be done at any other. The animal is moved under the direction of the Inspector, and destruction carried out in his presence.

If the place fixed for destruction is within the district of another local authority, their permission must be first obtained.

If the owner or person in charge makes no request to have the animal destroyed, it is moved to a convenient place by the Inspector, and isolated for such time as the local authorities think expedient ; but the animal may at any time be destroyed at the request of the owner or person in charge.

If the owner or person in charge makes a request for destruction while the animal is isolated, and during this time it proves to be diseased, it shall be dealt with just as if it had been found diseased when seized.

When a diseased animal has been exposed in a public place, especially a market, sale-yard, etc., the market authorities, or owner, or occupier of the place, is not again to allow it to be used for equines until a Veterinary Inspector has certified that that portion of it has, as far as practicable, been cleansed and disinfected.

The expense connected with the seizure of any animal may be recovered from the owner.

It is unlawful, excepting by licence, to send for transit by any means or method fodder, litter, or manure which has been in contact with or used with diseased animals. Such licence will only be granted by the local authorities, on the certificate of an Inspector, that the thing moved has, as far as practicable, been disinfected.

In the foregoing considerations, it will be observed that the owner is compelled by the pressure exercised to destroy his affected animal, or else, if a business man, to incur a heavy loss ; if the local authorities like they can ear-mark his establishment and completely close it so long as he keeps a diseased animal alive. A man may keep as many glandered horses as he likes alive, provided they are on his premises, or in a place so enclosed that an outside animal cannot be affected ; if the same owner allows one of these horses to stray, or to be led along a road, the local authorities can at once seize it and destroy it without reference.

This regulation may be sound law, but it is not common sense. There is no more reason why a man should be permitted, if so disposed, to bottle up glandered horses, than he is permitted to maintain pleuro-pneumonia cases alive, but the Order permits it, simply to avoid giving compensation.

Under Sections 19 and 20 of the Diseases of Animals Act, 1894, a local authority may be empowered by the Board to give compensation for certain diseases other than cattle plague, and these sections have been made applicable to glanders.

A local authority may, therefore, *if they think fit*, destroy any glandered animal, unless the owner objects, in which case reference must be made to the Board.

Any suspected animal may also be destroyed with the consent of the owner.

Compensation in these cases falls on the local rates, and is fixed at such sum as the local authority thinks expedient, being a minimum of £2 for a diseased horse, and if compensation be given above the minimum it is not to exceed one fourth the value of the animal immediately before it became diseased.

If on destruction of a suspected animal it proves to be healthy, the full value of the animal immediately before destruction is paid as compensation, the sum being previously agreed upon between the local authority and the owner. Where no such agreement has been made, there are definite rules laid down in the Order for determining the amount.

Although it is illegal for an owner to send a glandered horse in a vehicle, local authorities may employ a properly constructed cart for the transit of glandered animals to suitable places of destruction. The regulations require that the vehicle shall be cleaned immediately after use, the floor and walls being scraped and swept, the scrapings, sweepings, litter, and manure, being effectually removed and mixed with quicklime, after which the van is thoroughly washed or scrubbed with water, and a coating of lime-wash applied.

The carcase of every animal dead or destroyed from glanders, shall either be buried, burned, or destroyed\*chemically, all under the eye of the local authority.

If buried there must be at least six feet of earth on top of the body, and the latter covered with a sufficient quantity of quicklime or other disinfectant, the skin being freely slashed.

If the carcase is to be cremated or treated chemically, the local authority must hold a licence from the Board to enable this to be done; it is then carried out under the inspection of the local authority, being first disinfected, and then taken in charge to the place approved for the above purpose.

If the burial or destruction of the carcase is carried out in the



district of another local authority, their previous consent is required, or else a licence of the Board.

It is an offence to dig up a carcase except by licence of the Board. It is an offence to move an animal dead or alive in contravention of a regulation made by a local authority under the Glanders Order, or of the conditions of a movement licence. It is an offence if any animal is not marked in accordance with any regulation of the local authority, the removal or attempt at removal of this mark is also an offence. If anything is omitted to be done as regards any cleansing or disinfection it constitutes an offence against the Act.

### TUBERCULOSIS.

The interest which attaches to tuberculosis is twofold, first its extraordinary destructive effect on bovines, and the extent to which it exists among certain herds; secondly, its relation to what appears to be an identical disease in man, and the possibility of its communicability from bovines to man and *vice versa*.

The disease in all animals is due to a bacillus, since the discovery of which in 1882 by Koch, dates such exact knowledge as we at present possess. The bacillus does not appear to be quite the same in each animal, though the destructive lung lesions and infectivity are practically identical.

The common seat of tuberculous lesions in bovines are the lungs, bowel, mammary gland, kidney, and generative organs; in each of these the organism grows. The seat of election depends apparently on the lymph stream, secondary infection of the other organs occurs from the lungs, whilst the lungs obtain the organism by inhalation or ingestion.

In days gone by the most common method of infection was believed to be by hereditary transmission, but abundant observations have proved that though a constitutional predisposition does play a part in infection, yet the hereditary nature of tuberculosis may practically be neglected. Of the progeny of tuberculous cows probably considerably less than 1 per cent. are affected with the disease at the time of birth.

An inherited tendency is very different from hereditary transmission; there are certain animals, rodents for example, where the inherited tendency is very marked, they can rapidly be made tubercular, for their tissues afford a favourable soil, but the disease is not the result of hereditary transmission.

A clear understanding of this fact exercises the most important influence in the hygiene and treatment of tuberculosis; if animals are not born tubercular but are made so, then the question of control is simplified. What the hygienist has to consider is how animals are made tubercular, and when this is understood control can be exercised.

The destructive lung lesions when sufficiently advanced cause coughing and the ejection of sputum. Microscopical examination and experimental inquiry have placed beyond all shadow of doubt that the sputum of a tubercular patient contains the bacilli of the disease.

Every act of coughing therefore ejects into the air of a building a certain number of organisms, of which it is permissible to believe all do not survive. It is quite certain that the bacilli once ejected cannot multiply outside the body, for a constant temperature near that of the animal body is required for this purpose. These bacilli will therefore in course of time die, but their death is not immediate; in the first instance they are fixed in the moist expectorate, but later on the sputum dries, and in this condition the still living tubercle bacilli rise with the dust in the air, by which means they find their way again into the lungs by inhalation.

This simple explanation of infection is of the utmost importance to the hygienist; a tubercular animal in the midst of health is a focus of infection, and it is obvious that the probability of infection is infinitely greater in an enclosed space like a cow-shed than in the open air. In fact, the risk of infection in the open can hardly be measured, for the evidence on that point is insufficient.

Infection in closed spaces is intensified by a stagnant atmosphere, such as in a badly ventilated byre, by over-

crowding and exposing a large number of susceptible animals to infection, and by the absence of sunlight, the presence of which is fatal to the bacilli.

Dark, ill-ventilated, and overcrowded cattle sheds cannot of themselves produce tuberculosis, but once a tuberculous subject is introduced into such, all the conditions for infection exist in the most complete form.

If stock owners would but take this lesson to heart, the first step in the eradication of this plague would be made; if affected animals are allowed to remain among the healthy there can be but one result; if a case of the disease is introduced among healthy stock the results can be easily foretold. Herein lies the entire question of the eradication of this disease from our herds; expense and indifference alone stand in the way.

The three epizootic cattle diseases previously described are very highly infectious, but not so tuberculosis; prolonged contact appears essential for infection, the disease moves slowly, so much so, in fact, that an animal may be a focus of infection, and yet present every sign of health.

In this respect one's sympathies are with the stock owner, who naturally fails to realize that what appears to be healthy stock can in any way be dangerous, and it is not surprising if he finds a difficulty in believing the tale that tuberculin is capable of unfolding.

Turning now to an extremely vexed question, which is still far from settled, we must consider how far bovine tubercle is capable of being conveyed to man, and what risk is incurred by humans in the consumption of milk and flesh of tuberculous animals. We may at once say that the communication of the disease from animal to animal by infected flesh or milk is a point long ago settled by experimental inquiry and admits of no doubt whatever.

The real point at issue is whether man can be infected in this way; this opens up the immense question of milk and meat supply, and whether it is possible for man to be affected by using the flesh and milk of tubercular animals.

Had the question been asked a little over three years ago

not the slightest hesitation would have been felt in placing at the door of the bovine a considerable share in the production of tuberculosis, but the authority of Koch has declared it otherwise; he regards human and bovine tuberculosis as distinct diseases, and states that the human disease cannot be transmitted to cattle, and indicates, though he does not expressly deny, that the bovine disease cannot be communicated to man.

In consequence of Koch's views the Royal Commission on Tuberculosis was directed to inquire, among other points, into the question of whether the disease in animals and man is one and the same.

The Commission has now made an interim report on this vitally important question, and arrived at the conclusion that tubercle of human origin can give rise in the bovine animal to tuberculosis identical with ordinary bovine tuberculosis.

The Commission rightly deprecates any framing or modification of legislative measures, in accordance with the view that human and bovine tubercle are specifically different from each other, and that the disease caused by the one is a wholly different thing from the disease caused by the other.

The transmissibility of tuberculosis to animals of the same species cries out for legislation, but nothing has yet been attempted in this respect. An affected cow is permitted to remain in the same shed as healthy animals, though it is a focus of infection.

Where expense is no object it is a perfectly simple matter to stamp out tuberculosis in a herd, and to prevent its further introduction; but excepting in the case of pedigree stock, the cost of such a system is prohibitive without the aid of the State.

This matter of compensation must be looked at from the tax-payer's point of view. He may very reasonably say he has paid to stamp out cattle plague, pleuro-pneumonia, and foot and mouth disease; that he is now paying to stamp out swine fever, and that he cannot, without too heavily

penalizing himself, deal with more than one disease at a time. The legislator may ask for evidence of a sincere desire on the part of owners to rid themselves of this plague by adopting preventive measures; while experts must not be of two opinions as to the absolutely necessary steps to adopt.

It is conceivable that some such thoughts are influencing those whose duty it is to legislate, for compensation is a heavy drain on the public finances, and without compensation the disease cannot be exterminated or only by very slow degrees.

What then are the slow degrees by which in course of years this disease may be brought under control?

The first is the rigid isolation of all affected cases; the second is to afford animals better hygienic surroundings, so as to decrease their susceptibility.

The isolation method among dairy stock is now on trial in Denmark, and is encouraged by certain aid from the State. The isolation to be effective must be complete, the affected animals are kept by themselves and have separate attendants; their standings are submitted to thorough disinfection, so as to destroy all germs be they from the air-passages, kidneys, or bowels. The calves are isolated from the diseased animals and only receive milk which has been heated at 85° C., or boiled, and in this way a healthy stock is reared. The milk of all reacting animals is not given to the calves but used in the dairy.

The diseased animals in this method of eradication are first determined by the use of tuberculin. Strange as it may appear, no attempt is made to prevent men suffering from tuberculosis from being in attendance on the cattle, as Professor Bang, who has initiated this system of eradication, considered the risk inappreciable.

Such a system, as indicated above, is in the hands of every cattle owner; it has yielded the most promising results in Denmark, and is based on common sense and a knowledge of the infectious nature of the disease. It does not interfere with the milk-supply, though of course if assumes that the milk of animals suffering from tubercu-

losis of the udder is not employed. Its expense would not appear to be great, and if universally adopted would in a marked degree lower the proportion of tuberculous animals in the United Kingdom, and open the road in course of years to the final extinction of the disease by compensation.

So widespread is tuberculosis amongst our herds, that measures of extermination must be gradual unless the country wishes to be involved in a ruinous expenditure.

So far as we at present know, it is probable that on the average at least one quarter of our cattle are affected, and one third of our milch cows. In individual herds it may vary from 7 per cent. to 50 per cent. Not so far from our own door, viz., in the Channel Islands, tuberculosis is very rare; in our possessions in South Africa it is practically unknown.

For all practical purposes tuberculosis may be considered a disease of the bovine; both horses, swine, and sheep, suffer, but the latter so rarely that only two or three cases have been recorded amongst British sheep, though on the authority of McFadyean there is no difficulty in infecting the animal experimentally.\* Horses, according to the same observer, suffer more frequently than is supposed. Pigs are commonly affected.

*Tuberculin Testing.*—The testing of animals for tuberculosis by means of *tuberculin* has enormously reduced our previous difficulties in diagnosis. We can now pick out with considerable accuracy nearly all tuberculous animals. A possibility of error does exist, even when the operator has immense experience, but the margin of error in expert hands is small, and in dealing with such a disease as tuberculosis is negligible. It is hardly necessary to add that the tuberculin used should be above suspicion, and that the syringe employed should be in thorough working order so that the full dose may be injected.

The defects in the method are that an animal may not react until some time after infection, and that an advanced case may not give a distinct reaction. This latter is not so

\* *Journ. Comp. Path. and Therap.*, vol. xv., part ii., p. 103, 1902.

serious as the former, as an advanced case may be diagnosed clinically.

A tuberculous animal injected with tuberculin gets as a result a febrile reaction. It is the character of this febrile reaction on which the diagnosis is based, and it is in judging of the febrile reaction that error in non-expert hands may occur.

The first essential is to know the animal's temperature before injection, and its usual daily variations. When this has been ascertained the tuberculin temperature offers little difficulty, provided that we pay less attention to the height the mercury rises, and every attention to the manner in which it rises. The rise should be gradual, the temperature being taken at the 6th, 9th, 12th, and 15th hours, the maximum point being reached at the 12th or 15th hour after inoculation, after which it gradually falls to normal. Where the thermometric curve is an irregular rise and fall such a temperature is not tubercular.

It is of supreme importance that the animals should be free from fever, not exposed to sudden variations of temperature, and living under their ordinary conditions; very little change in their mode of life will cause the temperature to rise, and no more potent cause of this can exist than strange or unusual surroundings. Fig. 189 shows a temperature curve of a tuberculous animal after the use of tuberculin, and also that of an animal injected with tuberculin but non-tuberculous.

McFadyean found that an animal infected with a large dose of bacilli reacted to tuberculin eight days afterwards, but it by no means follows that a case will react in this short time to infection naturally contracted.

Even after the exercise of due care there may be certain doubtful cases which will require retesting, but this should not be applied for a month or more after the first inoculation, as the animal may acquire a high degree of tolerance to tuberculin. The indications for retesting are where the temperature curve is suspicious, but not typical, and where a temperature of less than 104° F. is obtained.

Bearing in mind that perfectly healthy animals are liable to fluctuations of temperature, it is essential that some scale should be laid down as a guide to the observer. Nocard considered a rise of  $1.4^{\circ}$  F. as insignificant; one of from  $1.4^{\circ}$  to  $2.5^{\circ}$  F. as being only suspicious and requiring retesting at the end of a month; while a rise of  $2.5^{\circ}$  to  $5.4^{\circ}$  F. is characteristic of tuberculosis.\*

The use of tuberculin and allied substances excepting in skilled hands should be forbidden. There is nothing to prevent the unscrupulous selling all their reactors to some-

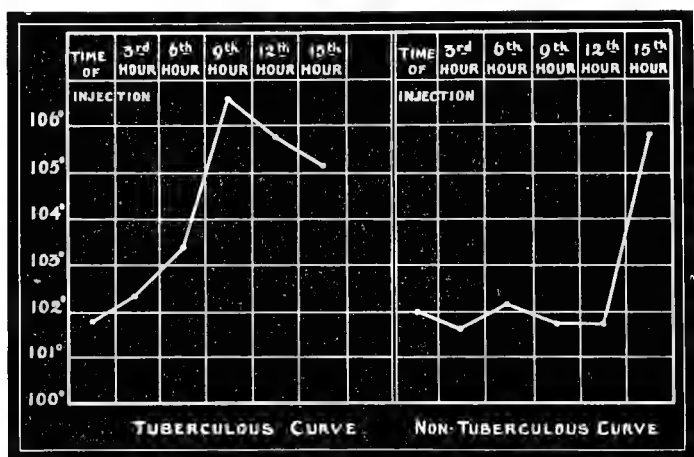

Fig. 189.—Showing a tuberculous and non-tuberculous Thermometric Curve after the injection of tuberculin.

one else. Perhaps the only safeguard to prevent this occurring, is by the manufacturers of these powerful preparations refusing to sell to anyone but qualified persons.

One other point may be touched upon before closing this section, and that is the possibility of immunising cattle against tuberculosis. McFadyean has shown that it is possible to confer a very high degree of immunity,† and doubtless this important point will be more fully determined

\* Professor Delépine: 'The Stamping out of Tuberculosis,' *Journal of Comparative Pathology*, vol. xiv., No. 3, 1901.

† *Journal of the Royal Agricultural Society*, vol. lxxiii., 1902.



in future, as it is one of the pillars of eradication of epizootic diseases.

The relations of tuberculosis to meat and milk supply will be found dealt with in the chapter on Municipal Hygiene.

Occasionally persons are met who are really anxious to free their herd from tuberculosis, and to whom the cost is not a matter of great importance. In such cases tuberculin is invaluable, with destruction of all those that react. It need not be supposed that the flesh of those destroyed is unfit for food, only the diseased portions need be dealt with, excepting in the case of generalized tuberculosis, when the whole carcase should be destroyed. The sale of the meat is therefore an asset to be considered.

In the case of dairy stock the loss of milk would be a far more serious financial question, though even this would be to an extent provided against by dealing only with those cows that are dry and prepared for the butcher, and isolating those in milk until a suitable time arrived for dealing with them.

With the entire destruction of reactors must follow the thorough disinfection of the buildings occupied by the cattle, so as to kill any bacilli left behind. In replacing the stock the greatest care must be taken that none are admitted until they had been quarantined and tested with tuberculin.

Working on these lines Delépine\* cleared out the infected stock from a small private herd at a cost of about £5 a head. The Cheshire County Council in a somewhat similar experiment carried it out at a cost of £5 16s. a head.

Delépine, in the paper quoted, shows how desirable it is if herds are to be kept free and to avoid unnecessary pecuniary loss, that the condition of the dairy stock should be ascertained before they are three years old, and therefore before they become an important source of income. In the above cases the loss on the capital of animals destroyed

\* Professor Delépine : 'The Stamping out of Tuberculosis,' *Journal of Comparative Pathology*, vol. xiv., No. 3, 1901.

5 years old and upwards, he found to be 38 per cent.; from 3 years to 5 years 30·86 per cent.; from 1 year to 3 years nil. In the Cheshire experiments the loss was less; 5 years and upwards 12·47 per cent. on capital; 3 years to 5 years 13·33 per cent.; 1 year to 3 years nil.

The interest in these experiments consists in knowing from actual observation what the cost of freeing a herd roughly amounts to. It would be a comparatively simple matter in the case of fattening oxen, but for dairy stock the loss of even five pounds a head, with probably the temporary paralysis of the man's trade, are conditions that are difficult to accept with a light heart.

#### LEGISLATION.

Here is the sole legislation with reference to Tuberculosis enacted by Parliament.

##### *The Dairies, Cowsheds and Milkshops Order of 1885.*

*Article XV.*—If at any time disease exists among the cattle in a dairy or cowshed, or any other building or place, the milk of a diseased cow therein—

- (a) Shall not be mixed with other milk; and
- (b) Shall not be sold or used for human food; and
- (c) Shall not be sold or used for food of swine, or other animals, unless and until it has been boiled.

An Order published in 1899 makes an important addition to the above Article XV., for the purpose of the provisions of paragraphs *a* and *b*.

Disease in the Order of 1889 includes, in the case of a cow, such disease of the udder as shall be certified by a Veterinary Surgeon to be tubercular.

The enactment then, is this, that tuberculosis of the udder is scheduled, but there is nothing to prevent the sale or use of milk from a reacting animal unless the udder is affected.

#### ANTHRAX.

Anthrax is a widely spread disease and found practically all over the world. The extent to which it exists in a country appears to be intimately related to soil temperature, for it is impossible for the organism to develop when

the temperature falls below 55° F., which accounts for a certain degree of immunity possessed by the British Islands. There are parts of the Continent where the disease is enzootic, but nowhere does it assume such alarming proportions as in tropical Asia, especially in certain parts of our Indian possessions.

One unpleasant circumstance connected with this disease is the fact that the number of cases recorded in Great Britain is on the increase. Professor Axe has recently\* made a careful analysis of the official returns, and especially draws attention to the increase of the disease between the years 1892 and 1902. He points out that the density of cattle population does not explain why the disease is more common in certain parts of England than in others; for example, the West Riding of Yorkshire has twice the number of outbreaks recorded as Devonshire, and has fewer cattle, and this is by no means the only example.

What Axe rightly insists on is that the increase of the disease in the kingdom is not due to existing virus suddenly waking into activity, but to importations of fresh infection from without, and obviously due to our foreign trade. Immense importations of wool and hair take place annually into the kingdom from India, Africa, Persia, and Asia Minor, and that this may be a source of anthrax infection is undoubted, for many cases occur among human beings engaged in its manufacture.

How animals may get infected from the wool and hair is by means of the waste water which has been used for cleaning the material, or by the application to the land of manure composed of the material which accumulates in sorting the skins.

It is quite certain that these may prove a source of soil infection, and Axe supports this view by pointing out that those countries in which the disease is exceptionally prevalent, are those in which the wool, pelt, and hair industries largely prevail.

\* 'Anthrax in Relation to Trade,' *Proceedings of the National Veterinary Association*, 1903.

There is another cause connected with trade which may be operating in increasing the number of anthrax outbreaks in Great Britain, and that is the importation of feeding stuffs. McFadyean was the first to show the influence of this source of infection. It may come in with linseed, cotton seed, hay, and oats. All these may be infected in the country of their production, or they may be infected during transit, as for example, by being carried on vessels which have previously been engaged conveying infected hides. The use of artificial and other feeding stuffs from abroad is greatly increasing, hay from Canada, lucerne hay from South America, cotton seed from the United States, Egypt, and India, linseed from Russia, and oats from everywhere.

In this way the chances of introducing infection are greatly increased, and without minimising the influence of waste water from hair, wool, and leather factories as a source of infection, we must not lose sight of food infection; the former may not produce disease, as animals may not have access to the infected waste on land, but the food is purchased to be eaten, and the risk of infection becomes very much greater.

In notorious anthrax countries like India there is no necessity to attempt to explain outbreaks of the disease, for the soil conditions are such as to favour the growth and development of the organism, viz., a sufficiently high temperature and moisture, and it is conceivable that the spores of the bacillus of years gone by may still be in an active condition in the ground, and only need introduction into the animal body to demonstrate their presence. In fact, it is known that in the soil spores may live for years, which explains why certain tracts of country are anthrax infected.

Koch, as opposed to Pasteur, regards the anthrax organism as a saprophyte, and only accidentally parasitic. In its saprophytic condition it lives and multiplies in stagnant water, or on the surface of the ground, and on plants, forming spores during hot weather, which, through the agency of floods, are carried over the land.

Outbreaks of anthrax in India are almost invariably associated with a recent rainfall. The disease is practically limited to the wet season, and the influence of rain in distributing the spores can easily be understood. Actual infection occurs through the food, and probably in no other way; hay grass or other substances are collected from the surrounding country, washed in pools to get rid of adhering mud and dirt, and brought in by hand.

With an alteration in the system of food-supply in India, viz., by cutting and storing hay, and getting rid of the bundle of wet grass, a great reduction in the number of anthrax cases has been brought about, the credit of which is entirely due to the persistent representations of the Veterinary Department.

No matter where the disease occurs, it is safe to say it must be either by food or water, and never by contagion.

An outbreak of anthrax generally begins by finding one or several animals already dead; in a temperate climate like ours the disease may be limited to one or two cases at long intervals; but in the tropics it is much more active, and we have on many occasions had to do with outbreaks which have carried off twenty or thirty animals in a few days.

The incubation period is short; according to our observations, a good dose of bacilli gives the disease by the digestive canal in 70 hours, but it is conceivable natural infection may be a little longer. There is frequently a preliminary rise in temperature which enables suspects to be picked out and placed by themselves, or even treatment adopted, but when a severe outbreak exists there is no time for taking temperatures; the cases having all been infected about the same time become simultaneously affected, and keep one employed.

In the course of four or five days the outbreak has passed, unless further infection results.

The method of dealing with the disease depends upon the country and the animals infected. Taking anthrax in India, and the horse as the subject, the first thing to do is

to evacuate the stables or lines ; this simple measure is often attended by the best results, and the camp should be moved after every fatal case has occurred.

It is not easy to explain the action of this method, it certainly removes susceptible animals from possibly infected centres, and from ground which has been soiled by the discharge from the sick ; but moving about *per se* is difficult to explain as a preventive measure, though of its value we have had many opportunities of judging.

If the sacrifice is not too great, it would be well to destroy what remains of the forage unless it can be so treated as to render it harmless ; but though this might be attempted in the case of grain, with hay or dried grass, which is the more likely source of infection, no means exists of disinfecting it in bulk, so it had better be burned, provided the intensity of the outbreak justifies this course being adopted. No loss, of course, is incurred by dealing with the hand-gathered bundles of Indian grass which should be at once disposed of.

The administration of drugs as a preventive is useless ; we know of no disease, excepting horse-sickness of South Africa, where one feels so utterly helpless in the face of a big outbreak ; but it is evident a change of food-supply and water is desirable, especially avoiding those parts where grass has recently been dug up, which may be the identical place from whence the disease was originally derived.

In dealing with outbreaks in England both the food and water supply should be changed, the latter as a precautionary, the former as an essential measure. If certain pastures are recognised as being infective, it is common sense to avoid them. If the subjects are cattle the feeding cake should be looked to, and none given without it being boiled as a precautionary measure ; if horses both the oats and hay should receive attention. If the oats cannot be sacrificed they can be boiled, the hay on the other hand had better not be risked.

Every outbreak must be dealt with on its merits, and the hasty destruction of a large quantity of hay is to be depre-

cated, unless circumstances seem to especially point to it as the infecting medium.

The evacuation of the affected buildings is most desirable until they have been disinfected. Disinfection for anthrax is a matter of the greatest importance; the bacillus is easy enough to destroy, but if sporulation has taken place, the destruction can only be effected with difficulty. Mercuric chloride, or izal, in recognised strength (see 'Disinfection') must be employed, and the entire building as a precautionary measure dealt with on the lines previously laid down, or such modification of it as appears suitable to the case.

The disposal of the dead should be by burning or burial at moderate depth. Superficial burial is dangerous, as the oxygen in the soil enables the bacilli to sporulate; at greater depths this does not take place; but burial is a serious undertaking where many animals have to be disposed of, and cremation (see p. 412) is in every way preferable.

On no account should the bodies be opened if burial is practised, as spore formation will occur, nor should blood be allowed to remain on the earth or further infection may result.

McFadyean, in his Annual Reports to the Royal Agricultural Society, year by year impresses on agriculturists the grave danger of feeding pigs on portions of animals which have suddenly died on the farm. He regards it as the most common method of anthrax infection in the pig, which shows itself by a typical swelling in the region of the throat, and death.

Care should be taken by those employed in the cremation of anthrax carcasses to avoid getting wounded when preparing them for the fire.

Finally, if circumstances render neither moderately deep burial nor cremation possible, the body should be left unopened on the surface of the ground and allowed to putrefy; the putrefactive organisms destroy the bacilli, but do not destroy the spores should oxygen gain access by opening the carcass.

Protective inoculation may be practised for anthrax. Pasteur's vaccination is made with two vaccines. The first is a pure culture of the organism grown for 24 days at a temperature of  $108.5^{\circ}$  F. The second vaccine is a culture grown for ten days at the same temperature, and inoculated ten to fourteen days after the first vaccine. The first vaccine kills mice but not guinea-pigs; the second kills both. By this method of inoculation herbivora get protection for about a year.

The value of anthrax inoculation is still an uncertain quantity, excepting in notoriously anthracoid districts where any reduction in the annual loss is welcomed. But in countries like Great Britain, where the loss compared with the Continents of Europe or Asia is small, the mortality attending inoculation is hardly worth the risk. Sometimes the vaccines do their work well, at other times there is a somewhat alarming mortality, and when it is borne in mind that immunity is only temporary, it is doubtful how far the risk is worth running.

#### LEGISLATION.

*Diseases of Animals Act, 1894, and the Anthrax Order of 1899.*

Notification and duty of Inspector as on p. 497.

It is the duty of the local authority to inquire into the correctness of any reported case of the disease, the advice of a veterinary practitioner being obtained.

The owner and occupier of any premises in which a diseased or suspected animal or carcase exists is bound to give reasonable facilities for inquiry. No milk from a diseased cow may be removed from the place where the cow has been kept.

No animal may be moved into or out of any shed or other place where a diseased animal is, or has died, or been slaughtered, or kept at the date of death or slaughter, until the place is cleansed and disinfected, and the local authority satisfied that no diseased animal remains on the premises.

Any horse, ass, or mule may, if not diseased, be moved out to any other place. All other animals not diseased should be moved out by the owner, under the supervision of an Inspector, to some convenient place for isolation, where they are to be kept separated from other animals for seven days.



Any animal not diseased may be moved from the affected shed or isolation place under the supervision of an Inspector for the purpose of slaughter.

No broken fodder, litter, or anything which has been in contact with, or used for a diseased animal, out of a shed or other place where a diseased animal is or has died, or been slaughtered, or has been kept at the date of death or slaughter, can be removed without the authority of the Inspector, excepting to such an approved place where no animals have access. Whatever is removed shall be burned, destroyed, or disinfected, and, when practicable, buried to the satisfaction of the Inspector.

The carcase of a diseased or suspected animal shall be disposed of as follows :

It shall be buried in its skin (which is not to be slashed or cut) at some suitable place to which animals have not access, away from a dwelling, well, or watercourse, at six feet below the surface of the earth, and one foot of lime both beneath and above it. All natural openings before burial shall be effectually plugged with tow or suitable material, saturated in strong carbolic acid or other suitable disinfectant. In no case shall the skin be cut, or anything done to cause effusion of blood, excepting by the Veterinary Inspector for microscopical examination.

The Board may license the carcase being destroyed by fire or chemical agency, in which case it shall be removed under the superintendence of the Inspector to the place assigned, after all natural openings have been plugged as above.

Only the local authority can bury or destroy a carcase of either a diseased or suspected animal, and only the same authority can remove from the premises a body for destruction or burial.

Disinfection and cleansing of infected premises, utensils, vehicles, etc., is carried out at the expense of the local authorities, under the direction of an Inspector.

The place is first sprinkled with freshly-burned lime or other suitable disinfectant, and then swept out, all dung, broken fodder, etc., in contact with or used for any diseased animal being effectually removed.

The floor and all other parts with which the diseased animals can have come in contact are washed, scrubbed, or scoured with hot water ; they are then washed over with freshly-burned lime, each gallon of lime-wash containing four ounces of chloride of lime, or half a pint of commercial carbolic acid, or some other suitable disinfectant. The lime-wash must be freshly prepared. In the case of a field, or other place that does not lend itself to disinfection, the place must be cleaned and disinfected as the Inspector may think fit.

Utensils, pens, fittings, vans, etc., must be thoroughly scraped, all

dung, litter or other things effectually removed, and the above routine method carried out.

As previously noted, all dung, litter, broken fodder, etc., from an infected place, van, vehicle, etc., must be burned or otherwise destroyed, and where practicable buried.

The usual facilities are to be given by owners or occupiers for cleaning or disinfection, or it becomes an offence against the Act.

It is unlawful to expose a diseased or suspected animal in a sale-yard, or other public place where animals are sold ; or to place it adjacent to healthy animals in places usually used for putting animals before sale ; or to send a diseased or suspected animal by road, rail, vessel, highway or thoroughfare ; or to place a diseased or affected animal on any commonage, or insufficiently-fenced field, or to allow a diseased or suspected animal to stray.

The Order by a special provision brings all animals, equines, ruminants, and swine, under the Act for the purpose of the powers of inspectors and police, but not for compensation.

The Act assumes that the owner or person in charge of an animal is presumed to know of the existence of the disease, unless it can be shown that he had no knowledge thereof, and could not with reasonable diligence have obtained it.

The offences are moving animals in contravention of the Order, removing, burying or destroying a carcase, or allowing an animal to stray in order to defeat the operation of the Order.

#### QUARTER-EVIL.

This is a disease which for some time was confused with anthrax, and hence was spoken of as symptomatic anthrax. There is nothing of the nature of anthrax in it ; it is quite a distinct disease, possessing many features entirely at variance with that disease.

The organism to which it is due can live apart from the body, and its habitat is the soil. In the soil it can multiply, and marshy or wet ground is particularly adapted to its growth. In these conditions it resembles anthrax, but its mode of infection is very different. Quarter-evil cannot be conveyed by ingestion ; food and water may be freely mixed with affected material without producing the disease ; nor can it be caused by simply skin inoculation : it is only when the virus is inserted into the subcutaneous tissues that infection is certain, and here the smallest particle of

material may suffice. It may be said that this is probably the only way in which cattle may be infected—viz., some wound which admits of the organisms in the earth penetrating into the subcutaneous tissues.

From this it may be judged that the disease does not spread from animal to animal in the sense in which this is usually understood.

The animals principally affected by quarter-evil are oxen and sheep, the former particularly. Age has an important influence in cattle; under two years old the disease is common, over that age it is rare. The influence of age is not seen in the case of sheep. Calves still suckling are generally considered to be immune, but McFadyean,\* whose views are here being represented, says that experimental inquiry does not bear this out.

The commonly assigned predisposing causes of the disease are rapid growth, excess of blood, forced feeding, or even the converse poverty of blood; but McFadyean rejects all these on the basis of insufficient evidence, and mentions that some experienced observers have held that liberal feeding reduces the mortality from the disease.

The mortality from quarter-evil is excessive, practically none recover, and death may occur within two or three hours of the attack, while with sheep it is still more rapidly fatal.

There is no putrefaction in the crackling tumour during life, but the carcasses rapidly putrify after death, and the organism which produces the disease, unlike that of anthrax, is not destroyed by the putrefactive change.

For many years the setoning of calves in the dewlap as a protection against quarter-evil has been practised, especially on quarter-evil farms where infection occurs year by year.† The scientific value of this measure is unknown,

\* 'Quarter-Evil': *Journal of the Royal Agricultural Society*, vol. ix., part iv., 1898.

† Quarter-evil lands have a very unequal distribution. There are whole counties in which the disease hardly ever occurs, and others in which it is only too common. Some farms may be badly affected,

but as the operation is harmless, and fully believed in by many in the profession and the majority of laymen, there is no reason why its practice should not be continued.

Other measures of protection which suggest themselves are improvement in the land by draining and crop growing; draining should prove particularly useful, and the remarks previously made on this subject may be consulted with advantage. It has been clearly proved that in many black-quarter districts improved methods of farming have been followed by the almost entire obliteration of the disease.

The avoidance of affected pastures is an obvious precaution not always practicable; but it might be possible, as suggested by Kitt, to prevent young animals in process of shedding their teeth, or others with wounds on the limbs, having access to pastures notoriously affected. Even the precaution of preventing grazing and converting the grass into hay may not be successful, as exclusively stall fed cattle in Baden and Württemberg are not infrequently affected.\*

Protective inoculation has been largely practised on the Continent of Europe with undoubted benefit, but no matter what care is taken, a certain mortality, which is sometimes alarming, must be expected from the operation.

McFadyean recommends that individual owners should be informed that the mortality from inoculation may vary from  $\frac{1}{2}$  to 10 per cent. He attributes the mortality which sometimes follows black quarter and anthrax inoculations to the differences in individual susceptibility, which varies within rather wide limits; so that a vaccine perfectly safe for some, may prove too strong for others where the powers of resistance are below the normal.†

The protective substance is obtained from the disease

---

while others close at hand are quite healthy, and even on the same farm the disease may be confined to certain fields (McFadyean, *Journal of Comparative Pathology*, vol. xv., part iv., 1902).

\* 'Veterinary Pathology': Friedberger and Fröhner.

† *Journal of Comparative Pathology*, vol. xv., part iv., 1902.

tumour, and attenuated by heat. Sometimes two inoculations are made at intervals of a few days, with a virus of increasing virulence. The first vaccine employed is mild, and it is the second on which the protection depends. The seat of inoculation is generally near the tip of the tail.

McFadyean sums up the position of protective inoculation by saying it is an operation attended by considerable risk, but that on farms on which this disease annually causes loss, the danger of the operation is outweighed by the prospect of the protection it confers.

Animals dead of quarter-ill should be cremated or buried deeply in places to which neither cattle nor sheep have access. The body should not be opened in order to avoid soil infection; the blood during life seldom contains the bacilli, but they are abundant a few hours after death. Soil contamination should be avoided as the spores which are always present in the bacilli are most difficult to destroy. It is said that even after six months' burial the contagium is still present.

All excretions from the sick, litter, etc., should be destroyed by fire.

#### BRAXY.

Very little is known of this curious disease, which solely affects sheep, and presents in some of its symptoms and lesions a relationship to both malignant œdema and quarter-evil. Yet it is neither, but a distinct disease due to a spore-forming bacillus which has been isolated and from which the disease has been produced by inoculation.

Braxy appears confined to certain parts of Scotland, Iceland, Norway, and Denmark, affecting more particularly animals under a year old, rarely attacking those not yet weaned, seldom affecting those two years old, and practically never affecting three year old sheep. There is evidence to show that certain herds of sheep enjoy immunity, and that those living in infected areas may get the disease in such a mild form as to subsequently become

immune. Where the disease is fully developed it is excessively fatal, and runs a very rapid course.

Infection like that of quarter-evil cannot be conveyed through the alimentary canal, but may readily be conveyed by subcutaneous inoculation.

The disease principally occurs in the late autumn and early winter months, and disappears before the winter is over.

The poison is probably introduced into the system through the fouling of the ground caused by the bodies of infected animals being left unburied, and their excreta not destroyed. The spores are most resistant, and Professor Hamilton of Aberdeen, who has published\* the most recent researches on this subject, regards these being carried about by wind and in other ways, as a common source of infection. One thing seems quite clear, and that is infection by the mouth is very unlikely, for experimental enquiry has always failed to induce the disease by this channel.

#### LOUPING-ILL.

This is a curious and obscure epizootic disease only affecting sheep; it is common in many parts of Scotland and Northumberland, but not known south of the latter county. It does not affect large areas, but attaches itself to certain districts, though a fence may separate affected from non-affected pastures.

It appears to be a purely nervous disorder attacking the muscles of the head, neck, and limbs, and finally producing complete paralysis.†

It is confined to certain months of the year, lasting from the middle of April to the beginning of June, and then vanishes for a year. If the affected flock be removed from the pastures and others put on they will contract the

\* *Transactions of the Highland and Agricultural Society*, vol. xiii., 1901.

† McFadyean, on whose article in the *Journal of the Royal Agricultural Society*, vol. v., 1894, these remarks are based.

disease. The affection is not contagious, nor can it be reproduced by inoculation with any of the diseased fluids and tissues.

Local farmers blame a particular white tick as the cause of the trouble, and this view was held by the late Professor Williams. Our recent knowledge regarding tick infection renders it possible, but in connection with this, there is evidence to show that sheep on farms which are not tick infected may suffer.

The whole question of the pathology of the disease is quite obscure, so that no method of prevention which is not based on conjecture or guessing can be suggested.

#### INFECTIOUS DIARRHŒA OF CALVES (WHITE SCOUR).

This disease is one of the banes of the farmer, and is widely spread over the three kingdoms. Through the severe losses it occasioned in Ireland, where in places it was impossible to rear a calf, the services of the lamented M. Nocard were secured to investigate the nature of the disease, with the result that considerable prominence has of late been given to the affection, though not more than it deserves.

Nocard regarded the disease as a Pasteurellosis, and that the organism gained entrance into the system mainly, if not entirely, by the umbilicus; this view has not been accepted by McFadyean, who states that no organism has yet been definitely associated with the disease, though doubtless one exists, and he regards the channel of infection as in all probability by the digestive canal.\* The question of the identity of the organism is not at present settled.

The disease makes its appearance very soon after birth, sometimes as early as a few hours, more commonly between the second and third day, rarely later than the sixth. It is attended by a very high mortality, sometimes all the

\* For a full account of this question, see communication by Professor Mettam, B.Sc., M.R.C.V.S., to the *National Veterinary Association*, 1903.

calves on a farm being carried off, and even should any recover Mettam records the frequency of a fatal pneumonia occurring in such.

It is important to observe that 'White Scour' should not be confused with the form of diarrhœa to which calves are liable three or four weeks after birth; the two conditions are quite distinct.

Whereas Nocard and Mettam regard the umbilicus as the chief source of infection, McFadyean and others look to the mouth as the principal means by which the organism gains entrance to the body, while the chief vehicle of infection is the diarrhœal discharges of affected calves. That these discharges are infective appears beyond all doubt.

The disease may be introduced by new purchases affected with the disorder, some of which may have been sold owing to the disease breaking out on some other farm, and are got rid of before they contract it.

A consensus of evidence points to the filthy surroundings of the calving box as mainly responsible, and the uncleanness of those in attendance. The infection may be conveyed by the attendants from diseased to healthy calves, and this must be regarded as a common cause of infection.

So great have been the losses amongst some farmers from this disease, that the cows have been turned out into the open to calve and take their chance, and this has been attended by the best results.

In controlling this disease what we have to look to are the hygienic surroundings of the calving box and calf shed; where a case of the disease has occurred the most thorough disinfection should be practised, flooring, bedding, walls, feeding trough, etc.

Not a portion of these should escape disinfection, on the lines laid down in the chapter dealing with this subject, and where the place does not lend itself to disinfection it should be abandoned as a calving place.

We should also take care that thorough disinfection of the umbilicus of the calf is practised, and the parts



protected against any possible risk of infection by this channel.

It has been suggested that infection may occur in the maternal passage during parturition, if so the employment of antiseptics may prevent it; but doubtless the chief points to attend to are the hygienic surroundings of the parturient animal, and the cleanliness of those in attendance especially of the hands.

Where these measures fail to control the disease there is almost certain to be some undiscovered source of leakage, and the method adopted of letting the cows calve in the open, entirely away from the infected building, should be adopted.

Should the disease occur among a collection of calves the place should be at once evacuated, and the most rigid isolation of the affected cows and their attendants be insisted upon; without this probably the whole will be lost. The building occupied by the calves must be thoroughly disinfected, and not occupied again for some time.

The hands of attendants should be scrubbed with soft soap and water after the nails are pared, and then scrubbed with Hyd. Perchlor. 1-1000. The ease with which the virus can be conveyed on the hands of attendants must never be forgotten, and no one should be allowed in the parturient box until the hygiene of the hands has been attended to.

During the outbreak, a vessel containing a reliable disinfectant should be conveniently placed, so that hands, clothing, and boots may be disinfected as necessary.

Those employed looking after the sick should not on any account be allowed near the calving box whether disinfected or no. The slightest want of care on their part will convey the disease; the attendants as well as the calves should be rigidly isolated.

#### CONTAGIOUS FOOT ROT OF SHEEP.

Mistakes may be made between this disease and non-contagious diseases of the feet in sheep. If the cases

are seen early, Brown\* tells us there can be no possible mistakes made; contagious foot rot begins as an affection of the skin between the digits, and from this extends to the sensitive structures of the foot, causing them to be cast off. Non-contagious foot cases, on the other hand, begin by affecting the horn of the digits, and subsequently the internal structures.

The latter form of the disease is due to the mechanical irritation of dirt, which finds its way in by any breach in the horn, while specific foot rot is a highly contagious malady readily communicable from sheep to sheep through infected pastures.

Brown's experiments show that the disease may be produced by the introduction of infected matter between the digits, or by inoculation, and probably even when taken by the mouth from contaminated pastures.

Foot rot cannot be produced, as is popularly supposed, by wet and undrained lands, by coarse or wet herbage, or by standing on wet and rotten litter and manure. The above authority kept animals for many months under these conditions and produced nothing, while on being exposed to infection they contracted the disease in from fourteen to twenty-one days.

Regarding the period of incubation it may vary from ten to twenty days or even longer, and in this way infected animals showing no sign of the disease may be introduced into a healthy flock.

Foot rot may be checked by the regular examination of the feet, if possible three times a week, when the early stages of the disease may readily be seen and controlled by the application of carbolic acid and glycerine, or the animals may be driven through a trough containing a solution of carbolic acid.

Owing to the long incubative period which sometimes exists in foot rot, the best method when the affection is

\* 'Contagious Foot Rot in Sheep' (Professor J. T. Brown): *Journal of the Royal Agricultural Society*, vol. iii., part ii., 1892. I am indebted to this article for the facts here related.

known to be present, of preventing the disease from being introduced among sound sheep, is the isolation of all new purchases for a month. Further, at such times it is well to regard all sheep which have been sent to market and brought back again as possibly affected, and deal with them on the above lines as suspects.

#### EPIZOOTIC DISEASES DUE TO PASTEURELLA.

Pasteurella organisms are known to affect a large variety of animals, and to give rise to a group of diseases originally known as Hæmorrhagic Septicæmias. According to Nocard Pasteurelloses may be classified as follows :

Pasteurelloses of Horse—Influenza, Infectious Pneumonia.

Pasteurelloses of Cattle—Septic Pleuro-pneumonia of Calves, Diarrhœa of Calves.

Pasteurella of Sheep—Pneumo-enteritis observed in the Argentine.\*

Pasteurelloses of Swine—Contagious Pneumonia, Swine Plague, Swine Septicæmia.

Pasteurella of Dogs—Distemper.

The above organisms are known as cocco-bacteria, and give identical cultural and morphological characteristics, which enable them to be grouped into one family. They are very universally distributed, and may be found in food, soil, and water, also in the respiratory and digestive tracts of the body. Ordinarily they are saprophytes, but they are capable of becoming parasites, and herein their hygienic interest lies.

The pasteurella of the horse may be found as a saprophyte in the nasal chambers, and under ordinary conditions appears to do no harm, but under others, it is capable of producing toxins which infect the body, and though these toxins give rise to no specific symptoms, yet

\* There is a pasteurella of the goat, an infectious pneumonia, observed by Hutcheon in 1881 in Cape Colony it has also been seen in India.

they reduce the natural powers of resistance. In this way they facilitate a secondary infection by other organisms, some of which are natural to the body and ordinarily harmless, but after the preliminary action of the pasteurilla toxin become pathogenic. Thus in the horse may be produced catarrh, sore throat, influenza in its various forms, and infectious pneumonia, the pasteurilla paving the way and other organisms, naturally saprophytic, completing the process.

A very good example is afforded by the disease distemper which is produced by a pasteurilla; while the complications, such as pneumonia, are brought about by an organism normally present in the mouth and nasal cavities of the animal, excited into pathogenic activity by exposure to cold.

It is convenient to consider catarrh, sore throat, influenza, strangles and contagious pneumonia together, as modern bacteriology assigns to them a common cause, viz., the microbe known as *Pasteurella equi*, supplemented in the case of catarrh, strangles, and pneumonia by a streptococcus which is probably identical in all these affections.

Influenza, with its many varieties and complications, its widespread or local ravages, its comparatively benign or remarkably virulent forms, has been known for many years, but the identity of the organism producing this protean malady has only recently been made clear through the work of Lignières and others.\*

The degree of disease which this organism is capable of developing may vary from a common catarrh, sore throat, or simple fever, to 'pink eye,' pneumonia, or enteritis; even purpura is included in those diseases in which the pasteurilla paves the way for other organisms to build upon.

\* Full information on the subject, to which we acknowledge our indebtedness, is given in an excellent address by Mr. H. Gray, M.R.C.V.S., to the Eastern Counties Veterinary Association, *Veterinary Record*, March 19, 1904. See also a most valuable paper, 'Pneumonia in the Horse, its Etiology,' contributed by Mr. J. A. Dollar, M.R.C.V.S., F.R.S.E., to the *Proceedings of the National Veterinary Association*, 1902.

The primary microbe may vegetate as a saprophyte outside the body in forage, manure, soils, and in the surroundings of animals; under unknown conditions it becomes pathogenic. The organism has been found in the nostrils of healthy horses, but in them it has a low degree of virulence.

It has been proved by experiment that cultures of the pasteurilla of the horse which have become 'exalted,' if injected subcutaneously cause acute influenza, pneumonia, pleurisy, or peritonitis. If the cultures be introduced into a vein they may cause enteritis or acute influenza.

Climatic and meteorological conditions, a collection of young horses, bad hygienic surroundings especially as regards ventilation, even food, have all been blamed as causes in exciting the saprophyte to become pathogenic. Certainly the majority of these causes fit in with clinical experience, influenza is more virulent in hot, close, badly ventilated stables, and very fat or young horses are common victims.

In the light of these researches we can explain that very common and nearly always fatal pneumonia met with on board ship; also those cases seen at sea which cannot be distinguished from influenza ashore.

Under the influence of board ship life, with its overcrowding, defective ventilation, and impure atmosphere charged with excreta, all the conditions are present for the generation of the disease, assuming, as we think we must, that the organism can be found in healthy horses, and only needs adverse surroundings to stimulate its pathogenic activity.

Once the activity of the influenza microbe is established, it is quite clear that it can be conveyed from animal to animal by actual contact, by infection of water or food, and, as experience shows, by stallions during coitus.

Clinical records furnish abundant evidence on these points; the newly purchased horse may introduce influenza into a clean stud, or a ship load of affected animals may bring it into a town apparently previously free from the

disease. Horse repositories, dealers' stables, livery and bait stables, etc., are probably never free from it. And in this connection may be noted the risk of infection from railway horse-boxes, which are seldom properly disinfected.

So intimately associated is an ordinary catarrh with symptoms which are spoken of as influenza, that this frequency can scarcely be accidental.

Horses taken up from grass and put in stables develop catarrh, or they change from one stable to another and this is also followed by catarrh. In the past this has been considered to be associated with a chill or some such cause not always apparent. It can now certainly be explained on the supposition that the organisms capable of producing these diseases exist in the body or in stables as saprophytes, only waiting for the introduction of suitable conditions to produce infection.

The streptococcus of strangles multiplies in the nasal chambers, and from here is carried into the lymph stream.

McFadyean's researches\* show that the streptococcus of strangles cannot be distinguished from an organism present in a large proportion of fatal cases of pleurisy, and in the nasal discharge of severe catarrh cases, especially such as are met with in large cities. From this he concludes that many cases of so-called febrile cold are due to strangles though not diagnosed as such.

It is a wise hygienic measure to regard catarrh, strangles, certain forms of pneumonia, and influenza under its many guises as all infectious, though perhaps not of the same degree of virulence in every case. As to how long the infection lasts evidence is required, but it has been supposed in stallions that the poison of influenza lasts many months, during which, though apparently in health, they are capable of infecting mares.

The infection in buildings is not very difficult to destroy under thorough disinfection, but if the organism has a saprophytic existence, or is present in the nasal membrane

\* *Journal of the Royal Agricultural Society*, vol. ix., part i., 1894.

of apparently healthy animals, the chances of totally eradicating the disease are very small if not impossible.

The strict isolation of the class of case we have referred to, the disinfection of buckets and mangers, destruction of bedding, with separate attendants for the sick, are measures of the utmost importance, the rigidity with which they are enforced depending on the nature of the case.

For instance, the bedding in strangles gets freely infected when the abscess is opened, the manger, door, wall above and below the manger, and water-bucket are constantly exposed to infection, both in this and acute catarrh.

The greatest care should be taken to prevent buckets being dipped in the trough for the purpose of refilling, or the entire water-supply may become contaminated. All buckets should be filled at taps, all rejected food destroyed, the manger and walls around liberally disinfected daily, and any place where the animal persistently stands should be similarly treated.

Of actual preventive measures a polyvalent vaccine introduced by Lignières is mentioned in Gray's address, as conferring immunity in the horse and other animals against the pasteurilla.

For strangles, pneumonia, and purpuric complications, a polyvalent anti-streptococcic serum is used as a curative; but this is the pathological and not the hygienic side of the case.\*

#### MALARIAL CATARRHAL FEVER OF SHEEP.

This is an epizootic disease of sheep in South Africa, due to an organism which can be transmitted to the calf and from the calf to the sheep.

The blood of recovered sheep possesses antitoxic properties. This fact has been taken advantage of in adopting a system of protective inoculation, devised by Mr. Spreull of

\* In the above account it has been assumed that the views of Lignières are correct. But several objections have been urged against his theory both of distemper and influenza.

the Veterinary Department, Cape Colony. He uses a simultaneous inoculation of virulent blood and serum as a protective inoculation, or serum alone as a curative agent.

#### EPIZOOTIC DISEASES DUE TO PYROPLASMOSES.

*Hæmo-albuminuria (Texas Fever) — East Coast Fever of Cattle—Malarial Fever of Equines.*

In the chapter dealing with Bacteria, Dr. Theiler has drawn attention to the important group of Protozoa; we have now to consider certain diseases due to a member of this family, viz., the Pyroplasma.

These micro-organisms attack and live within the red blood corpuscles. In the ox one variety produces Texas Fever, another causes the devastating East Coast Fever or Rhodesian Red Water, which is at present such a serious plague in South Africa. In the horse and dog a pyroplasma produces epizootic malarial (biliary) fever, a distinct species in each case being responsible for the disease.

In all cases the affections are produced by the bite of a tick, which carries the organism within its body obtained from the blood of a pre-existing case, so that these diseases can only exist where there are ticks to transmit the affection.

Some, like Texas Fever and Biliary Fever, can be communicated by the direct inoculation of the affected blood; others, like East Coast Fever, can only be communicated by the bite of the tick, so that within the body of this parasite some further elaboration of the organism occurs.

In Australia 'tick fever,' as it is locally called, has been responsible for very heavy losses. This disease does not differ from Texas Fever, or what is known in Europe as *Hæmo-albuminuria* or Red Water.

The blood of animals which have recovered is infective for a very long time, so that Red Water may be produced by the inoculation of an animal with blood from one apparently in perfect health.

It was this fact that caused so much trouble in the serum



treatment of Cattle Plague. Animals were immunised to a very high degree, and their serum was undoubtedly protective against Rinderpest, but unfortunately it often produced Red Water, owing to the animal selected for serum production having originally suffered from the disease.

Animals brought up in a Red Water district obtain a natural immunity against the disease, and the same may be said of Biliary Fever in horses, and East Coast Fever in oxen.

Ordinary *Texas Fever*, *Red Water*, or *Hæmoglobinuria* may be produced either by the injection of blood from an animal suffering, or which has suffered, from the disease, or by the bites of ticks which have previously fed on an animal affected with the disease.

The whole question of prevention hinges on the tick, and if tick eradication were possible, the whole group of diseases known as Pyroplasmoses would disappear.

The disease may be prevented from infecting a farm by the exclusion of strange cattle, and the thorough upkeep of wire or other fencing. Ticks will exist on such a farm, but are harmless until they have fed on an affected case.

In the purchase of cattle they should be obtained only from those districts known to be free from the disease, while the obvious precaution of keeping cattle free from ticks is easier to lay down than to carry out.

Baths for dipping cattle on an ordinary farm are out of the question on the score of expense, but spraying the cattle by means of special spray pumps, with either an arsenical solution or a mechanical mixture of paraffin and water are within the reach of all.

With dairy cattle which are handled daily no difficulty should be experienced in keeping the animals free from ticks.

Should the disease break out on a portion of a farm, the cattle on it should be isolated and dressed for ticks. It is perfectly safe to allow the healthy cattle to leave the infected area after they have been thoroughly freed from ticks both by hand and dressings, though the usual incuba-

tion period of the disease, viz., 10 to 12 days should elapse before moving them. The affected animals should remain where they are, and those that recover subsequently kept by themselves, for if they get tick infected they can convey the disease to others. The affected portion of the farm should be closed for at least a year.

Protective inoculation may be practised in this disease. For this purpose the blood of an animal that has passed through an undoubted attack of Red Water is taken; but care must be observed that at least two months after recovery should elapse before the blood is used for inoculation or Red Water may be produced. As much as 100 c.c. of defibrinated blood is employed, the object being to produce a mild form of the disease; the blood is injected subcutaneously. Immunity is not obtained until about 21 days after inoculation, so that cattle should not be exposed to infection before that time has elapsed.

Closely related to Texas Fever is the disease *East Coast Fever* or *Rhodesian Red Water*; it is, however, due to a distinctive parasite, and has many features quite different from Texas Fever, the chief one being that it is non-inoculable. Dr. Koch observed the disease first in German East Africa in 1897, and like subsequent observers mistook it for a severe form of Texas Fever.

The disease is transmitted entirely by ticks and in no other way (see p. 417). It is this fact which renders the future control of the disease such a difficult matter, as protective inoculation, if not entirely impossible, is at present outside the range of practical prophylaxis, as the length of time required (5 months) is so great, that all the animals would be dead on an infected farm before they could obtain immunity.

The incubation period, like that of Texas Fever, is about 12 days, and the fever period about 13 days.

No other animal than bovines is affected; the disease cannot be communicated to sheep, goats, or horses. The mortality is not less than 95 per cent., and once the disease has got into a district it is safe to assume all but 5 per

cent. of the cattle will die. Those that recover are immune, and the progeny of such cattle may obtain a certain degree of immunity; in this way is explained the immunity of cattle on the East Coast of Africa.

The existence of this disease in a country is a most serious outlook if 95 per cent. of the cattle are to die, and yet such must occur unless all movements of cattle are suspended. The tick responsible for the disease exists very generally, and is quite harmless until affected cattle are brought to the district. It is obvious, therefore, that the entire cessation of cattle movements are of the utmost importance, and if destruction of those in an affected area is too serious a political question, then affected areas must be fenced off. Such affected farms must not be stocked again with cattle for some time, and the affected ticks given an opportunity of feeding on insusceptible animals like sheep and goats, by which means the disease will gradually disappear.

Theiler and Stockman\* have made experiments to ascertain how long an infected area retains its infection after the withdrawal of all cattle; they have found that fifteen months is a safe period, and believe that further observation may show it to be less. They have decided one vitally important point, viz., that pathogenic ticks may remain active on an infected farm for at least six, and perhaps eight, months after all cattle have been withdrawn.

The removal of non-affected animals from an infected district is a serious question. They would need to be repeatedly dipped for safety to insure no ticks were carried by them; further, they would require to be quarantined in the meantime, in case anything developed. After removal to the new ground the dipping process would still have to be kept up to prevent any possibility of a case arising and infecting the whole district.

On this extremely important question of dipping cattle, the latest observations of Thieler and Stockman† show that the application of dips in a badly infected area gives no

\* *Transvaal Agricultural Journal*, No. 9, vol. iii., 1904.

† *Op. cit.*

guarantee against the further spread of the disease, and no hope for extinguishing an outbreak unless the animals are also removed to a fresh pasture, which, as we have mentioned, is a serious risk to run. It is true that systematic dipping, as mentioned p. 422, will reduce the number of ticks on a farm, but it is principally those varieties of ticks which remain on the animal for several days which are thus exterminated. The life history of the brown tick shows that the intermediate stages drop off in three days, and it would be impossible to catch these by any periodical dipping possible, especially when poisonous dips like arsenic, or irritating ones like paraffin, are used.

Public dipping tanks have proved themselves in this disease to be a source of infection, healthy cattle becoming affected with the ticks dropped by diseased cattle.

In a European country the entire destruction of the affected herd would be necessary, with restriction against stocking with cattle for many months. Koch proposes to immunise animals by the repeated injection of the blood of a recovered case at intervals of fourteen days. The process is a long one, and takes four or five months before immunity is said to be established. Gray in Rhodesia found it to be useless.

Theiler and Stockman are of opinion that to trust to dipping alone to keep off East Coast Fever is useless. If a farm be non-affected in an affected district, the only way to maintain it in this condition is to fence it, never allow the cattle to go off it, nor permit fresh cattle to enter until they have undergone a six weeks' period of quarantine.

*Equine malaria*, or *Bilious fever in horses*, is another disease due to a pyroplasma, and is presumably tick infected; the disease never occurs as an epizootic excepting among horses at grass, and then only affects those foreign to the country, home-bred stock having complete immunity. The disease has been described by Hutcheon in Cape Colony, Theiler in the Transvaal, and Verney in Natal. The intensely jaundiced condition is due to the liver getting rid of the broken-down red corpuscles.

The incubative period is about twenty-one days; one attack probably gives immunity. Recovery is frequent in cases treated early, otherwise it is very fatal. The preventive treatment is not to expose horses foreign to the country to infected pastures, and to keep them free from ticks. It is to Theiler that we are indebted for a clear account of the disease and the discovery of the parasite.\*

Pyroplasmosis of the donkey has been described by Dale.† In the donkey there is no jaundiced condition as in the horse, though the parasite (also discovered by Theiler) is very like that of the horse and mule, if not identical with it. The disease is amenable to treatment.

#### EPIZOOTIC DISEASES DUE TO TRYPANOSOMATA.

*Surra—Tse-tse—Maladie de Coït—Gall-Sickness—  
Mal de Caderas—Gambian Horse Disease.*

These diseases are due to a trypanosome in the blood of animals, and in all but one case, noted below, it is probable that a blood-sucking insect is the means of infection. No practicable means of prevention is known, protection from fly attacks by avoiding those districts known to be affected is at present the only thing to be done.

Something may, however, be done to prevent a country becoming infected, by the quarantine of all animals from affected countries and the examination of their blood. Should the disease find its way in, destruction of all affected is the only course to pursue. In this way the Dutch stamped out 'Surra' in Java.

*Surra* particularly affects horses, though cattle and dogs are known to be attacked. In cattle it is a benign disease. In *Tse-tse* disease, horses, cattle, and dogs are all equally affected, and in each equally fatal. *Dourine* or *maladie de coït* is essentially a disease of equines, and conveyed under ordinary circumstances exclusively by sexual

\* *Journal of Comparative Pathology*, vol. xv., 1902.

† *Idem*, vol. xvi., 1903.

intercourse. *Gall-sickness* is confined to cattle, and not at present known outside South Africa. *Mal de caderas* is a disease of horses in South America, which shows itself by progressive paralysis of the hind-quarters, and anæmia.

Surra is very widely distributed in India and Burmah, where it causes at times immense loss. Infection probably occurs from animal to animal through some biting insect, and may readily be conveyed by inoculation. The disease is attended by a marked progressive anæmia, and is invariably fatal. No protective measures are known; excepting to move animals out of those districts where the disease is enzootic.

*Tse-tse* disease is positively known to be conveyed from animal to animal by a blood-sucking fly (see p. 427). The fly obtains the organism from the blood of wild cattle, which though themselves immune, have the organism in their blood. The symptoms are much the same as in Surra, viz., progressive anæmia, and the disease is invariably fatal. There are large belts in Africa along the coast-line, and in low-lying districts, where no domesticated animal can live owing to this parasitic pest, and this will continue so long as game is preserved.

*Maladie de coït* is a well-known disease in some parts of Europe, though fortunately the United Kingdom has hitherto escaped infection. It is a most serious source of loss in breeding establishments. The disease progresses very slowly, and it is said may lie dormant in the system as long as a year before manifesting itself. Besides the local lesions on the generative organs, there are paralytic symptoms and progressive anæmia. There is no question but that all animals affected with the disease should be destroyed, and their surroundings thoroughly disinfected. This is the only known trypanosomata disease transmitted by contact.

*Gall-sickness* is an excessively common disease among cattle in South Africa. Many diseases are confused under this term, but Theiler has proved the existence of a trypanosome in the blood, and has infected animals by

allowing them to be bitten by a blood-sucking fly. The disease cannot be produced by inoculating with the blood, and is the sole exception in this respect to the group to which it belongs.

*Gambian horse disease*, due to a trypanosome, has recently been discovered by Dutton and Todd in Gambia. It is attended by anæmia and slight paresis.

#### SOUTH AFRICAN 'HORSE SICKNESS.'

This disease, to which no name has been given excepting the above, is the scourge of equines in South Africa. During certain years it causes immense losses, and invades parts of the country which are usually free; in other years it is comparatively mild. There are certain places where it is enzootic, and the disease may be looked for with great regularity. Such places are low lying, and are frequently associated with malarial attacks in man.

Altitude is a great protection, so much so that it is a common custom for farmers to send their horses away to higher ground from unhealthy places before the season begins. At the same time there are low-lying places in Cape Colony, for instance, where the disease is seldom seen.

The organism which produces this affection has never been seen owing to its extreme minuteness, nor has it been possible even with the closest grain of porcelain filter to separate it from the blood.

Yet the blood contains it and is highly infective, one drop being sufficient, as a rule, to produce the disease. There is also another remarkable feature about the infecting agent, and that is it may be kept for years in blood without losing its virulence, in spite of the fact that the blood is putrid and swarming with bacteria. In this respect it is in great contrast to all known poisons of infective diseases, which generally die when kept any time apart from the body, or in decomposing fluids. The blood may be kept in an ice chamber or exposed to a temperature of 140° F. without losing its virulence, but drying easily kills it.

How infection is produced is still a debated point, but considerable evidence has been accumulated to show that it must be due to some blood-sucking insect which is generally absent during the day and present at night. Bearing in mind the habits of the mosquito, this theory is not difficult to understand, in fact Theiler, the greatest authority in South Africa on veterinary bacteriology, believes that some variety of mosquito is responsible. The mosquito is possibly merely the simple carrier, as is the case with the Tse-tse fly, but where the mosquito obtains the poison is still a mystery.

The disease is essentially one of the hot and wet months, November to April; it is usual to look for its disappearance a few days after the first general frost in winter, and excepting in some places where it is enzootic nothing more is seen of it for some months.

The influence of dew and wet grass has been much debated; the Dutch farmer implicitly believes in it, but as a cause it does not stand the test of experimental inquiry. Even the dew has been collected and used for inoculation, but with no results. On the mosquito or blood-sucking insect theory we can understand why dew has been associated in the minds of the Dutch with the cause of this disease. The insect is perhaps entirely nocturnal, it objects to buildings, preferring the open, and it is in the open left out grazing all night that horses get most severely infected; dew has nothing to say to it.

As Theiler points out there is no means of explaining how the disease could come in the dew, and even if it were possible the first sun would kill the virus on the grass, for as he has pointed out a few hours' drying at ordinary temperature is sufficient to kill it.

The influence of shelter is remarkable, horses in stables enjoy comparative immunity provided they are stabled before sundown and not taken out again until after sunrise. Nor is it necessary that the stable should be closed; we have seen extraordinary protection afforded by stables without doors and with very incomplete walls.



There are places where horse sickness is very virulent and stabling does not afford complete protection, but as a general rule the statement may be accepted.

If grass were the cause of introducing the virus into the body, experimental infection by the digestive canal should be easy; as a matter of fact it is extremely difficult, a dose of virulent blood many thousand times greater than that required for hypodermic inoculation is required to produce infection.

Inhalation has been held by many as the chief source of infection, and nosebags soaked in a disinfectant are frequently employed for horses that have to go out at night, the nosebag acting, it is supposed, as a filter. Again this theory is not supported by experimental inquiry, even the intra-tracheal injection of the virus is not always followed by the disease. It is more in accordance with our knowledge of the disease, to regard the fine skin of the muzzle when grazing as a likely seat of attack by a blood-sucking insect, and the nosebag on horses working at night may act by protecting the skin of the muzzle.

The insect theory explains how the disease may travel over the Continent, and why it is worse some years than others. It also explains why the wet season and proximity to water are unfavourable conditions, why altitude gives relative protection, and further, why the disease ceases quite suddenly a few days after the first general frost.

The disease consists essentially in the outpouring of serum into the subcutaneous tissues of the head and throat, or the effusion of serum into the lungs, thorax, and pericardial cavities. There are other lesions, stomach and bowel for instance, but those that kill early and certainly are the effusions into the pericardial sac and lungs.

The mortality is high especially from the chest form, while when the head and throat become affected the chances of recovery are better; should recovery occur the animal is practically immune, though second attacks have been observed.

The incubation period is from ten to fifteen days, or on the authority of Theiler as long as 25 or 30 days, though these are exceptional.

The preventive measures consist in keeping animals away from river-banks, watercourses, or low-lying wet land, especially during the night. Stabling is essential, as previously pointed out, and the stable should be placed on high ground. The benefits of altitude are remarkable, even 40 or 50 feet may be of the utmost advantage. Smoke from burning litter is recommended to be kept going during the night outside the stables, it may help to keep away blood-sucking flies, and as a preventive should not be neglected.

No animal should be permitted out of the stable between sunset and sunrise; if this is found an impossible restriction a nosebag soaked in a solution of izal or creosote should be worn.

Arsenic internally administered throughout the sickly season has been advocated, but is of doubtful value.

Protective inoculation may be practised by Theiler's method, viz., the simultaneous injection of virus into the jugular vein and of serum from a hyperimmunised animal under the skin. Theiler's serum takes a long time to prepare, and a large dose is necessary, but it completely prevents the disease with mules, and probably horses, with a loss of about 10 per cent. It is to be hoped that some method of reducing the time taken in the preparation of the serum, and of the dose required, may be forthcoming.

Bearing in mind the extraordinary vitality of the organism, care should be taken in disposing of the dead to avoid soiling the ground, to disinfect all places occupied by diseased animals, and especially the discharges from their body, particularly the nasal passages. It is no use talking of cremation in a country where there is no wood, but deep burial should if possible be practised.

## EPIZOOTIC HEART-WATER.

This South African disease, for which there is no other name than the above, affects cattle, sheep, and goats. It is limited to certain areas of Cape Colony and the Transvaal, preferring, like 'horse-sickness,' low-lying and warm pastures.

It is an inoculable disease but not contagious; the organism has never been seen, but Robertson has filtered it from virulent blood\* so that it should come within the limit of visibility.

The disease is transmitted by a tick known as the Bont-tick (*Amblyomma hæbræum*) either in the nymph or adult stage, but the virus does not pass from the female into the egg. Wherever the particular infected tick is found the disease is perpetuated, but excepting in heart-water districts the same tick is harmless.

As the bont-tick can only live at certain altitudes and among bushes, the confinement of the disease to certain localities, and its disappearance where altitude fails to give the needful warmth, are easily explained.

The incubation period in natural infection is from eight to ten days though it may vary from five to fifteen. Cattle, sheep, and goats, placed on affected pastures soon succumb, but animals reared on such pastures have an immunity. Hence the common sheep and goat of the country lives and thrives in parts absolutely fatal to high-class stock.

Robertson and Lounsbury have pointed out the remarkable immunity possessed by Persian sheep to the disease. Crosses between the Persian and South African breeds produce an animal which can live and thrive on virulent heart-water pastures, where all other sheep and goats die.†

The preventive measures are to move animals at once from infected pastures to higher ground, and to keep them

\* Report of Chief Veterinary Surgeon, Cape Colony, 1903.

† *Agricultural Journal Cape of Good Hope*, August, 1904.

free from ticks by baths, such as have been previously described (p. 422).

The veterinary authorities in Cape Colony, especially Mr. Spreull, have been working for some time to devise a means of protective inoculation against heart-water, and the work in this direction is hopeful.

#### EPIZOOTIC ABORTION.\*

The animals affected by this are the cow, mare, and ewe; in the former, and probably in all, an organism is at work, though not necessarily derived from a previous case of infection. There is evidence to show that sporadic outbreaks may occur independent of contagion as their starting point, the organism responsible for the trouble having been leading a saprophytic existence outside the body, probably in the soil.

The organism isolated by Bang in epizootic abortion of the cow produced the disease in 37 per cent. of the animals experimented upon; pure cultures of the organism isolated by him produced abortion whether injected into the veins of cows, mares, and ewes, or merely placed in the genital passage. The effect of the introduction of this organism was to produce an infectious metritis.

Though soil infection is not unlikely as a starting point, it is probable the disease is more frequently introduced into a herd or stud by an apparently healthy though really affected animal. A bull, for instance, which has served an infected cow, is for some time capable of infecting others. A stallion which has suffered from influenza may be the means of causing abortion in the mares he serves for many months after his apparent recovery.

\* This section is based on the following published papers: 'Abortion in Cattle,' Prof. Brown, C.B., *Journal of the Royal Agricultural Society*, vol. xi., p. 4, 1891; 'Epizootic or Contagious Abortion,' Prof. McFadyean, *idem*, vol. lxii., 1901; 'Management of Aberdeen Angus Cattle,' C. Stephenson, F.R.C.V.S., *idem*, vol. v., 3rd series, part i., 1894.

The abortion bacillus may retain its vitality for some time outside the body, a point of great practical importance in dealing with the question of disinfection, and the disposal of abortions and excreta from affected animals.

Epizootic abortion in the mare is not so common as in the cow, but is attended by much greater risk and severe constitutional symptoms. Besides metritis, pneumonia and laminitis are common in this disease. The affection may be introduced into a stud by mares which have recently aborted, and no doubt also from mare to mare, as from cow to cow, by infection carried by attendants. The period of incubation is also shorter in the mare than in the cow, in which latter it may, as the results of experimental inquiry, be as long as two months, or even longer.

McFadyean in the paper previously quoted, the substance of which we are here giving, draws attention to the fact that in the ewe abortion generally occurs within a week of full term, from which he supposes that the poison affecting the cow can hardly be the same in the ewe, or abortion would occur as in the other animals at any period of the pregnancy. Bang's experiments, however, show that the poison of the cow can produce abortion in the ewe, though as McFadyean expresses it, it cannot be positively stated that a contagious form of abortion does occur in sheep.

The prevention of abortion is a most important matter, and the subject may be divided under two heads, viz., the best method of preventing the introduction of infection into a herd or stud, and how to prevent its spread if once introduced.

The renewal of dairy stock from time to time is a most fruitful source of introducing the disease. A cow may be infected and give no sign of ill-health, even carry her calf to full term, and yet be the means of introducing disease. The isolation of new purchases is not, therefore, a very promising preventive. The risk of introducing disease is less with heifers than with cows, but the only real safeguard is to purchase in those quarters where there is complete assurance the disease has not existed.

The bull and not the cow may be the means of introducing infection, especially where the bull is permitted to perform service on outside cows.

The practice of service being performed within a month or two after calving, increases considerably the risk of infecting the bull and of spreading the disease.

Abortion occurring among dairy stock must be regarded in a serious light, and every effort made to reduce the probable chance of the infection spreading, by the isolation of the cow at some distance, the destruction by fire or deep burial of the foetus in quicklime, the destruction of the membranes, bedding and excreta by fire, or deep burial in lime in some place where cattle have not access.

The evacuation of the stall is imperative, it must be thoroughly washed and disinfected with a 1 in 20 solution of sulphate of copper, which experiment shows to be destructive of the organism, and less likely to get mixed up with the milk than corrosive sublimate, and not likely to taint it like preparations of phenol.

This disinfection must be thorough, and repeated two or three times for safety. It should not be confined to the affected stall, but the entire shed done and the same repeated at intervals.

In Denmark good results have been obtained by freely sprinkling the floor with powdered lime.

The other cows must be watched, and any showing impending signs of abortion at once removed. Daily washing of their external genitals, anus, and root of tail with a 1 in 1000 solution of corrosive sublimate or other disinfectant may be practised, while newly calved cows may in addition receive a vaginal injection once or twice a day for a week.

The aborted cow is dangerous for a few weeks, and it is also probable she may infect others before she herself has aborted.

All isolated cows must have attendants to themselves; the above measures are of no use if the same persons look after both the sick and healthy.

Brown, in his communication previously quoted, lays especial stress on the fact that preventive measures must be persevered with for some time, as it is hopeless to see abortion cease at once. During the first year it will be less serious, but it will still show itself, for such cows as were infected when the preventive measures began will almost certainly abort. But, as Brown expresses it, all will cease as if by enchantment by the second year, provided care and exactitude have been paid to disinfection and isolation, and the owner possesses the needful patience.

Frequently cows which abort are fattened for the butcher, as there is a widespread belief that abortion will again occur; if they are not fattened they should still be kept isolated and a fresh bull provided, or if this is impossible the sheath and penis of the bull should be disinfected after each service. Cows should not, however, be put to the bull while there is a trace of vaginal discharge, and not until at least three periods of œstrum have elapsed.

Statistics regarding abortion in ewes show that they may vary from less than 2 per cent. to 24 per cent.\* Two-thirds of the abortions are less than 2 per cent., and McFadyean points out that when no higher than 20 per cent. contagion is not likely to be in operation, while when they are found to be from 30 per cent. to 50 per cent., and affect simultaneously several neighbouring flocks, a suspicion of contagion may be entertained. With sheep the interval which elapses between successive pregnancies tends to interfere with the spread of the disease.

In the paper quoted, the cause of ordinary abortion in ewes is attributed to the poor character of the food, and the consequent impoverished state of the animals.

#### RABIES.

There is nothing easier to deal with than rabies where a strong legislature exists, and few things more difficult when

\* 'Abortion, Barrenness, and Fertility in Sheep,' Mr. W. Heape. M.A., *Journal Royal Agricultural Society*, vol. x., part ii., 1899.

those responsible for the suppression of animal diseases are afraid to apply the law.

The disease can only be conveyed by inoculation, and the incubative period depends to an extent on the seat of injury; wounds of the face give rise to symptoms earlier than wounds of the limbs, owing to their close proximity to the central nervous system.

Most animals probably show symptoms within a month, though there are prolonged incubative periods extending over very many months, which are the exception rather than the rule.

On the occurrence of a case of rabies every dog within a radius of twenty-five miles should be muzzled, and this order should be issued by the Central Authority by telegraph to the police, so that all ownerless dogs may be captured and destroyed with the least possible delay. With a good administration, and energetic executive, not an ownerless dog should exist alive within that radius in three days.

It is not expected that muzzles will be obtainable locally in that time for all the dogs in a twenty-five mile radius, but until obtained the animals must be kept tied up, which in the event of a rabid dog being at large is a great safeguard.

Concomitant with this should be a rigid inspection by the Revenue Authorities of all dog licences. This would place many ownerless dogs into the hands of the police, for one of the chief objects aimed at is getting rid of the surplus dog population and the ownerless cur.

The muzzling order of the infected area should be for at least six months. Should a case occur on the margin of the zone, or at any distance from the original centre, another infected radius of 25 miles should at once be added.

There is scarcely a disease where the importance of a big infected zone is more essential than in Rabies, owing to the wanderings of the rabid dog. County muzzling is simply criminal; no question of county division should ever be considered where diseases are concerned.



The administration should place one large area under schedule, and rigidly enforce the Act.

The influence of centralized control in dealing with the disease may be seen from the following table, which shows the number of cases of Rabies in Great Britain for the past 10 years.

	Affected Counties.	Cases.		Affected Counties.	Cases.
1894	17	248	1899	4	9
1895	29	672	1900	2	6
1896	41	438	1901	1	1
1897*	30	151	1902	4	13
1898	10	17	1903	nil	nil

The muzzling order in affected districts came into operation on April 6, 1897, and the table just given† is eloquent testimony as to its efficacy.

We know for certain that for 55 years prior to 1903 Rabies and Hydrophobia existed in Great Britain, the latter malady claiming as many as sixty victims in a year (1885); yet six years of common-sense centralized legislation, with a deaf ear turned to a hysterical public, was sufficient to free the country from one of the saddest and most painful diseases man can contract.

There is no reason why rabies should ever again assume any proportions in Great Britain, though it is almost certain the disease will be introduced from time to time, until ships are forbidden to carry dogs. The public safeguard given by the Importation of Dogs Order, insures the disease will not be imported from abroad by dog-owners. It has been suggested that this Order is occasionally evaded, but a wholesome term of imprisonment for the first offender detected, without the option of a fine, would suffice to prevent a repetition of this selfish behaviour.

\* Muzzling in affected districts introduced April 6.

† Report of the Chief Veterinary Officer, Board of Agriculture, 1903.

## LEGISLATION.

*Diseases of Animals Act, 1894 ; Rabies Order of 1897 ; Importation of Dogs Order of 1901.*

Notification of disease falls upon the person having, or having had, in his possession an animal affected or suspected of Rabies.

The Inspector acting on any information obtained, proceeds to the place and discharges his duties.

The local authorities may placard a place where the disease exists, and may continue to do so during the existence of the animal, and until the place has been cleansed and disinfected.

The local authorities can compel the destruction of a dog which is affected, or one which has been bitten by an affected animal; but in the first place the owner or person in charge of the dog will be given reasonable facilities for this purpose. Failure to comply with this regulation is an offence against the Act.

Every case of rabies or suspected rabies that has either died or been destroyed, will be examined post-mortem by a Veterinary Surgeon specially appointed, and failure to give facilities for this examination is an offence.

Local authorities are compelled to secure the isolation of all dogs exposed to infection, notices to this effect being served on the owner or person in charge of every such dog.

Every dog will be considered as having been exposed to infection that has been in the same building, kennel, place, or otherwise in contact with any affected or suspected dog, or which has in any other way been exposed to infection.

The isolation imposed on an infected place insists on no animal being moved from, out, or into it, and no animal to be allowed to come in contact with those so isolated. The local authority can take steps to enforce compliance with this Order, while at the same time they inform the Board and the police of the district.

All stray dogs can be seized by the local authority. If affected with the disease, or suspected to have been bitten by either an affected or suspected dog, they are to be destroyed; if the animal has been exposed to infection it shall be detained in isolation, destroyed, or otherwise dealt with as the local authorities may determine.

Any dog seized which does not come under the above, shall be detained in some proper place, and kept there for such period as the local authorities may think expedient. If the owner or person in charge of such detained dog is known, a notice shall be served on him, and the dog given up on payment of expenses incurred. If the owner or person in charge of the dog does not claim it within two days after the Order is served the dog may be destroyed. If the owner is

unknown, and the dog not claimed within three days, it may be destroyed.

None of these provisions apply to the City and County of London.

Local authorities are compelled to dispose of the carcass of dogs destroyed for or suspected of rabies, by burial in its skin not less than six feet below the surface, and covered with quicklime or other disinfectant; or it may, after previous disinfection, be conveyed to a proper place and destroyed by fire or chemical means, under the inspection of the local authority.

A local authority may make regulations for the following purposes, viz., the cleansing and disinfection of any place used by a diseased or suspected animal, and anything used for or about such animal; for the cleansing and disinfection of any vehicle, other than railway, used in conveying any diseased or suspected animal. They may also prescribe the mode in which the cleansing and disinfection is to be carried out, and they may require the owner or occupier to do this, either at his own expense or that of the local authority.

Failure to disinfect and clean in accordance with regulations, necessitates the local authorities doing it at the expense of the persons concerned.

The Rabies Order makes a special provision to extend the Order to equines, all ruminants, and swine, by which, if diseased or suspected, they may be destroyed and compensation given out of the local rates.

The full powers of Inspectors and police under the Diseases of Animals Act, 1894, may also be exercised.

It is an offence to move an animal or anything in contravention of a notice served under the Order. If a carcass is removed, or not buried or destroyed, it constitutes an offence; similarly failure to cleanse or disinfect, or failure to keep a dog isolated, or wilfully allowing one to stray in order to avoid the operation of the Order, are all offences against the Act.

The *Importation of Dogs Order of 1901* is intended to prevent the reintroduction of rabies. It does not apply to dogs coming from Ireland, the Channel Isles, and the Isle of Man.

An imported dog cannot be landed in Great Britain unless its landing is authorized by a licence of the Board previously obtained, and when landed it is detained and isolated for six months on the premises of a veterinary surgeon, at the expense of the owner.

During this time it cannot be moved without licence, and then only to another place of detention, or to a vessel for exportation.

The only exception made to these conditions of quarantine are in the case of *bonâ fide* performing dogs.

Both performing and pet dogs are required to be confined in some place named by the owner and approved by the Board, and the super-

vision is kept up for six months. No exercise in the streets is allowed, and performing dogs are kept in the place of detention until required for performance. If the dog has to pass along a public thoroughfare or highway to reach this, it must be confined in a suitable receptacle.

Dogs landed for exportation within 48 hours are dealt with by an agent approved by the Board, and taken out of the charge of the owner. The agent then becomes responsible that the law is complied with.

It is the duty of the Customs officers to enforce the Order of ships' dogs not being allowed to leave vessels in British ports, or allowed to escape therefrom.

#### PUSTULAR STOMATITIS.

This is an infectious disease affecting the mouth of the horse, especially the interior of the lips, with frequently an eruption externally, which sometimes extends into the nostrils. The disease is said to affect other animals including man.

The saliva is infective, and the affection rapidly spreads through a body of horses; the symptoms are generally of a mild character, and run their course in a few days.

By some it has been described as variola of the horse, and as such we are inclined to consider it, but Fröhner and Friedberger say it is a distinct disease.

The chief means of infection is the saliva, and bearing this in mind the most complete isolation of the affected cases and their attendants is necessary. The bits and bridles, mangers, walls, and stalls, must be disinfected; water troughs should be emptied and disinfected, and no horse allowed to water at them until every mouth has been inspected. Buckets used for the affected cases should be filled at a tap, and subsequently thoroughly disinfected. To prevent the spread of the disease, daily inspection of all horses is absolutely necessary.

#### TETANUS.

The bacillus of this disease lives a saprophytic existence outside the body in garden mould, animal manure, and

other places. The organism sporulates, and the spores are destroyed with difficulty.

Infection in the horse generally occurs through injuries of the feet, but it is not uncommon after wounds, surgical or otherwise, and especially after castration.

The tetanus bacillus does not penetrate into the blood and tissues, but lives locally in the wound where it manufactures its toxin, the latter produces the characteristic symptoms of the disease.

The thorough disinfection of a place occupied by a tetanus patient is imperative, in the light of our recent knowledge. It is said that stable walls and surgical instruments may retain their infection for some months; we do not think this is in complete accord with clinical experience, but as a preventive measure it is most desirable nothing should be left to chance, and thorough disinfection should be practised. The complete disinfection of the part in all neglected injuries especially those of the feet is essential. A solution of iodine is said to kill the spores in a few minutes, and might be used for this purpose.

#### EPIZOOTIC LYMPHANGITIS.

This disease, new to British Veterinary Surgeons, has been known in Southern Europe for some time, and is also met with in the East, Egypt, India, and China. The late war in South Africa was the means of affecting Great Britain through horses sent home after the campaign.

The organism on which it depends is a cryptococcus, readily found in the discharge from the ulcers. A long period of incubation, probably seldom less than two months, is a very serious hygienic feature.

On the occurrence of the disease the most rigid precautionary measures should be adopted; the affected if not destroyed must be isolated, and bearing in mind that every droplet of discharge is loaded with the specific organism, the greatest care should be taken to avoid the patient being a focus for further infection.

The stable occupied by the diseased animal must be thoroughly disinfected, grooming kit, sponges, rubbers, etc., destroyed, bedding and nosebag burnt, saddlery and harness disinfected.

The most rigorous precautions should be adopted to prevent any existing wounds getting infected, and every possible care taken to reduce the number of stable and other injuries occurring, as the organism, so far as we know, can only enter through a cut or abrasion.

The daily inspection of all animals is very necessary; cases should be detected before ulceration has occurred, as in this way we may know that no further infection has resulted, and subsequent treatment is greatly simplified.

Bearing in mind the long incubation period of the disease, months must elapse before it is possible to declare the place free.

One of the most important precautionary measures is the antiseptic treatment of wounds, so as to prevent their getting infected. When flies are troublesome—and there is reason to believe they may carry infection—there is no dressing so useful as a mixture of creosote, turpentine, and oil; no fly will go near this. We are indebted to Captain Olver, A.V.D., for the information. Wounds dressed with this during the existence of lymphangitis ought never to become infected.

In hospitals wounds may become infected through the carelessness of dressers. To avoid this risk the parts should never be touched with the hand, tow or wool used for cleaning them must at once be destroyed, and the antiseptic employed should be applied with a syringe. The dressers employed looking after affected cases should not be brought in contact with any others.

There is good reason for believing that the soil may harbour the organism; it seemed quite certain this is the case in South Africa, so that a good, impervious, frequently disinfected stable floor is essential to the eradication of the disease.

## LEGISLATION.

*Epizootic Lymphangitis Order of 1904.*

Every person having in his possession a horse affected with or suspected of this disease, is directed to report the fact to the police, and as far as possible isolate the animal.

Every horse slaughterer who has in his possession a lymphangitis carcase is directed to report the fact to the police, who in turn report to the local authority.

An Inspector receiving in any way information of the existence, or supposed existence, of the disease should at once act. On the local authorities being informed they must cause a veterinary inquiry to be instituted to ascertain the correctness of the information; the owner or occupier of any premises on which there is a real or suspected case is compelled to give all reasonable facilities for this inquiry.

If the existence of the disease is established, the local authority is to take steps to secure the isolation of the affected or suspected cases, to prohibit the movement of such horse from out of the place of detention, and to prohibit any other horse coming in contact with the affected. The removal of any carcase, dung, fodder, litter, etc., which has been in contact with any affected or suspicious case is prohibited without the permission of the Inspector.

The Inspector may authorize the movement of any isolated case for its better isolation.

The disinfection of any place in which an affected case has been kept, and of all utensils, mangers, harness, or other things used about such case, is to be carried out at the expense of the owner or occupier of the place. The details regarding disinfection do not differ from those laid down for other disease, viz., sweeping up of litter and dung and mixing these with quicklime; scouring with water the floor and all other parts with which the animal has come in contact, and finally washing all these over with lime-wash or some suitable disinfectant. Failure to disinfect is an offence.

The carcase of every case of epizootic lymphangitis is to be disposed of by the local authority only, either by deep burial in quicklime, or by a high temperature or chemical means. Local authorities are to make regulations to insure this being carried out.

A similar Lymphangitis Order to the above exists in Ireland, but by including asses and mules in its operation, it is an improvement on the Order which applies to England, Wales, and Scotland.

## EPIZOOTIC ARTHRITIS.

This disease, due to septic organisms entering the system by the umbilicus, attacks foals, calves, and lambs. It is an extremely serious and very fatal affection, and is found to hang persistently to some breeding establishments, where it causes a heavy annual loss.

The organism in all probability always enters at the umbilicus, and though it is said that improper feeding of the dam, want of exercise, premature birth, or anything which during pregnancy debilitates the system of the mother, predispose to the disease, yet, in the majority of cases, we are compelled to look for causes operating from without. It is said that parturient fever in ewes and abortion in mares is often associated with the disease, and as these are dependent upon organisms which enter by the genital tract, infection of the umbilical cord, and subsequent general infection is possible.

It is, however, more likely that infection results after the cord is separated, and that dirty surroundings, soiled litter, or actual infection from the hands of attendants in tying or dressing the cord are the most common causes.

As the large majority of cases occur in males, it has been suggested that infection may result from the urine.

The preventive measures are attention to the hygiene of the surroundings and complete disinfection. On the first case occurring both dam and offspring should at once be completely isolated, also the attendant; if this is not done further spread of infection will follow. The stable, box, or lambing pen must be evacuated, thoroughly disinfected, and all bedding in contact with the affected, manure, etc., should be destroyed by fire. Attention must be directed to the umbilicus of the other animals, both it and the surrounding parts being thoroughly disinfected from birth onwards. This precaution should be taken for several days, as experience shows the disease may appear from seven to twenty days after birth.

The hands of the attendant should never touch the



umbilicus, the dressing being applied by means of a syringe.

If the dam is impoverished, liberal feeding in order to bring the milk up to standard is a necessary precaution, so as to reduce the susceptibility of the young animal to infection.

Lambing folds should be frequently moved if cases continue to occur, while with mares or cows if the building cannot be disinfected properly, owing to structural defects, foaling and calving should be allowed to take place in the open.

#### EPIZOOTIC OSTEO-POROSIS.

This disease has been described from several parts of the world, America, South Africa, etc., but nowhere does it appear to exist as an epizootic excepting at Hawaii in the Sandwich Group of Islands, and here the disease has been described by Elliot.\*

This observer is convinced that the disease is not of dietetic origin, nor due to the absence of lime-salts in the food; this is supported by the fact that the food consists of American hay, oats, bran, and barley. Elliot considers it is purely a climatic affection, and points out that the Island of Hawaii is divided into certain districts in which the rainfall and climate vary considerably. In the district which produces cases of osteo-porosis the rainfall is 150 inches annually; the other is dry and rarely favoured with rain, so that a mile or two on either side of the dividing line 'takes the traveller from fields sodden with moisture and covered with verdure, to a land which is arid and parched.'

The removal of animals from the wet to the dry district is followed by immediate improvement and recovery; in fact, the latter only occurs under these circumstances.

Heat, cold, and alternations of temperature have no effect in producing the disease. In the affected district the horses

\* In a most interesting and closely reasoned paper on 'Osteo-Porosis,' by Mr. H. B. Elliot, M.R.C.V.S., *Journal of Comparative Pathology*, vol. xii., part iv., 1899.

of the poor and rich are each equally liable, while in the non-affected districts no unfavourable surroundings or conditions produce the disease.

Elliot observes that the native horse is as liable as the imported animal to contract the disease, an interesting observation showing that there is nothing in the nature of an acquired immunity established. Yet he suggests the disease is microbic, and shows how in the infected district certain stables may escape while neighbouring ones suffer severely. Attempts to transmit the disease by inoculation have failed, though destruction of the affected animals in a stable has been followed by a cessation of the disease.

In South Africa the disease is well known, though excepting in one or two places is not common. It has been studied clinically by Captain Lane, A.V.D., who regards it as of dietetic origin, and due to the deficiency of lime-salts in the food. Particularly does he blame oat hay grown in a certain district. A change of diet, with especially the introduction of green food, has been found of the greatest benefit, also a change of locality. The influence of rainfall is not apparent in South Africa as in Hawaii; in fact, the disease occurred severely in one of the driest portions of the Colony, and at a time when there had been no good rains for two years. Race-horses in South Africa are known to suffer, and as these are, presumably, under the best conditions as regards feeding, it is certain that we have yet a deal more to learn about the disease. Personally, we regard the affection as microbic.

#### EPIZOOTIC OSTEO-MALACIA.

This disease has been fully described by Dr. Hutcheon,\* whom we follow in the following condensed account.

In the first instance it is important to note that Hutcheon regards it as a dietetic disease, and due to the absence of certain inorganic salts from the food. We lay

\* *Report of the Colonial Veterinary Surgeon, Cape of Good Hope, 1903.*

stress on this, as on p. 156 will be found the statement that there are no diseases of the lower animals attributable to this cause. Since those pages passed through the press the Report quoted has been received, and we do not hesitate to give prominence to Hutcheon's observations, which may be fully accepted from such a reliable source.

Cattle, sheep, goats, and sometimes horses, suffer over certain areas of South Africa from a highly inflamed condition of the cancellous tissue of the bones of the limbs, especially those of the fore-legs; the bone tissue softens and may readily be cut with a knife. What appears to be another form of the same disease is a paralytic condition of the hind-limbs, associated with a serous effusion into the brain and spinal cord, and inflammation and softening of the bones of the limbs.

Inoculation experiments fail to reproduce the disease, so there is no direct evidence of its being infective.

Hutcheon regards it as being due to the absence of calcium phosphate from the food. This he replaces artificially by the administration of bone meal, or bone ash, which acts as a preventive, and the disease entirely disappears. This observer is convinced of the preventive effects of bone meal; he says if given in sufficient quantity its action is most complete; it is of course aided by liberal feeding. The paralytic form of the disease is very fatal.

#### EPIZOOTIC OPHTHALMIA.

Epizootic Ophthalmia both of horses and cattle is common in South Africa. The form affecting the equine is the ordinary periodic ophthalmia of Europe, but in an epizootic form. The cattle disease appears to be limited to the cornea, and is curable by antiseptics; the horse ophthalmia is unaffected by treatment and most destructive. Both diseases are probably microbic; the ophthalmia of the horse cannot be transmitted by any known form of inoculation.

## INFECTIOUS DISEASES COMMON TO ANIMALS AND MAN.

The study of hygiene was stimulated by, in fact based upon, a desire to unravel the mystery which so often surrounds outbreaks of infectious disease. As education became more general, science was no longer satisfied with the explanation that disease was due to an act of God, but that there must be certain definite conditions existing which only required looking for.

A search for these led to a study of air, food, water, soils, drainage, etc.; in fact, no necessary conditions or surroundings of life have been neglected to throw light upon the all-important problem of how disease is produced. Unfortunately, this has not always been attended by satisfactory results; that disease can be traced to defective surroundings and local conditions we have had an opportunity for seeing, but that the particular class discussed in the present chapter could originate in this way was long disputed, and the argument finally crushed by the proof, so easy of demonstration, that the spontaneous origin of living matter is an impossibility.

We have seen that a study of the laws of health helped to account for the outbreak and spread of infectious disease, but did not go far enough; everything was reduced to conjecture until the new science of bacteriology revealed an unknown world to our senses, and explained with precision, and by the simplest methods, what was previously utter darkness.

It was Pasteur's work which gave the death blow to the spontaneous origin of infectious diseases; the youthful science of bacteriology has, ever since that time, gone on year by year unravelling the mystery surrounding infection, with the most astonishing and often unexpected results.

There are some infectious diseases peculiar to certain animals; for example, strangles only affects the horse; cattle plague and pleuro-pneumonia, the ox; swine fever, the pig; sheep-pox, braxy, and louping-ill, the sheep; distemper, the dog; scarlet fever, diphtheria, and typhoid

fever, man. There are other diseases communicable from animal to animal, but limited to certain species; for example, foot and mouth disease may affect cattle, sheep, pigs, and man; glanders affects the horse, some minor animals like the guinea-pig, and man; finally, there is a group of diseases which seems common to all the domesticated mammals as well as man, viz., tuberculosis, anthrax, and rabies.

In the search for the origin and transmission of disease in the human subject, the fact that certain diseases are common to animals and man has been the basis of many errors in public medicine.

Those diseases which are transmissible from animals to man, are so certainly transmissible as not to leave the slightest doubt in the mind of anyone. We may here conveniently recall the dictum of McFadyean, that 'In the whole range of Pathology there is not known a single instance of a disease that is common to three of the domestic species and yet does not attack man.' The diseases of animals communicable to man are as follows:

Cow-Pox,  
Foot and Mouth Disease,  
Rabies,  
Glanders,  
Anthrax,  
Tuberculosis,  
Tetanus,  
Actinomycosis,  
Ringworm (certain forms).

With the exception of tuberculosis, tetanus, ringworm, and actinomycosis, it is permissible to regard the others as purely diseases of animals, man only becoming infected with these through an animal suffering from the affection. In tuberculosis infection is not only from animal to man, but more commonly perhaps from man to man.

Nearly twenty years ago an attempt was made by the medical profession to connect some diseases of animals with the production of diphtheria and scarlet fever in man.

The mistake then committed could have been avoided had veterinary opinion been sought ; but the inquiry was conducted by medical men, who, necessarily, are no more capable of investigating the diseases of animals than veterinary men are of those affecting man.

When an infectious disease common to animals and man has to be investigated, both medical and veterinary forces must be combined for the purpose, and since the error alluded to above this has been done. When the combined forces have attacked the problem, the results have been satisfactory, of which the best example is tuberculosis.

To state the case referred to above as briefly as possible, it amounted to this, that an eruption on the teats and udders of cows, which was almost certainly cow-pox, was blamed for producing a condition of milk which caused a widespread outbreak of scarlet fever in London, and the dairyman was in consequence ruined. The next attempt made was to connect diphtheria of man with strangles of the horse. In both cases it is to be feared the inquiry was not entirely free from, perhaps, unconscious bias, as at that time there was a growing feeling in the office of the Local Government Board, that wherever human agency could not be traced in the transmission of disease, the cause was due to some animal affection of which the veterinary profession, in at least one case, had failed to take cognisance.

Nearly twenty years have since elapsed, and nothing has been added to our knowledge of the subject to in the least justify the position taken up by the medical investigators ; while the attitude adopted by the veterinary profession at the time, and consistently maintained to date, is that there is no disease of animals capable of giving scarlet fever or diphtheria to man.

Prejudice dies very hard. Two standard works on Human Hygiene include ' some ailment of the cow ' as the cause in man of scarlet fever, diphtheria, and probably enteric fever, while tetanus, it is hinted, has probably an equine origin !

The position of the veterinary profession relative to this question is very simple ; we deny the existence of a cow disease giving rise to scarlet fever, diphtheria, and enteric, and state that whenever the above diseases follow in the trail of the milk-pail, it is always due to the infection of the milk from human source.

On this point it is outside our province to enter any further ; the innumerable sources of milk infection through human agency are very manifest to those who know anything of the mode of milk collection and supply, and should be recognised by every medical man. If our drinking-water had to be drawn from an animal and delivered to us at the door after passing through a score of hands, it would be a more fruitful source of trouble than at present.

The veterinary profession fully recognises the gravity of milk as a medium of infection, but on unassailable grounds it refuses to believe that this is due to anything more than human agency.

## *SECTION II.—INSURANCE OF ANIMALS.*

Frequent reference has been made in these pages to the question of compensation for certain animal diseases, such as the State is expected to furnish, especially when a man's property is destroyed for the public good. By means of compensation diseases like cattle plague, pleuro-pneumonia, and foot and mouth disease have been abolished from this country, and none can doubt that the money was well invested in getting rid of these scourges. Compensation has not, however, abolished swine fever, for it may be laid down as an axiom that it is no use attempting compensation, excepting the stamping out machinery be perfect, otherwise it is a waste of public money.

That compensation for swine fever would have succeeded in attaining these results no thoughtful person will deny, had it been accompanied by a rigid, perhaps even aggressive, certainly ruthless policy, such as the State has a right to

enforce when it is giving in return a *quid pro quo*. We all know why this measure failed, but there was no need to purchase this costly lesson had common-sense prevailed, and a firm policy been adopted.

Compensation backed up by a policy of thoroughness in every detail will get rid of any disease; it would free England in a few weeks' time from tuberculosis or glanders if expense were no object; but assuming the money and the machinery existed, to what extent is it wise to carry this system of paternal government?

When the bread-winner of the family is taken away is compensation for his loss expected from the State? The case may not be on all fours with the destruction of the poor man's horse or cow, but the principle involved is much the same.

The fact is that it is incumbent on all to make provision against disease and death, and as we have previously expressed it, compensation is not an unmixed evil. A man does not keep horses, cattle, sheep, and pigs to look at but to make a profit out of. Is there any reason why a portion—a small portion—of these profits should not be devoted to insuring himself against loss by disease or accident? Is it not, in fact, an economical measure which should if possible be enforced, or at any rate encouraged by the State? Would not a mere fraction of the money spent annually in drink, gambling, or amusement be sufficient, if all stock-owners insured, to prevent the State always being looked to for relief when epizootics occur?

We hold no brief on behalf of the State, nor do we hold it entirely free from blame in this and allied matters; it is its duty in certain cases to direct public thought and opinion, and not wait until public opinion compels it to move. It was not public opinion that gave us our present Sanitary Laws imperfect as they are; it was the pressure exercised by the State, which awoke to a sense of its duty as the result of increasing density of population, and the invasion of disease.

What we advocate is a system of insurance, whether it is



to be carried out by the State or by local authorities is a question we do not feel competent to enter into. It is quite clear that every stock-owner should, if possible, be compelled to insure all his animals, with such assistance out of local or Imperial funds as may be necessary to encourage thrift, or to give the scheme a start. Such a system of insurance carried to its logical conclusion, as in Germany and Glasgow, provides that a stock-owner or butcher can also insure animals about to be converted into food, for possible rejection as unfit for consumption.

Times may be bad and profits small, the same cry judging from history, forms part of the creed of the agricultural community, but an extensive system of insurance would, if general, cost but little. Private companies at the present time, with only a small fraction of the public insuring, can accept a cow, including parturition risk, valued at £20, for £1 3s. per annum, and a farm or carriage horse of the same value for sixteen shillings a year.

It must not be supposed that we have proposed anything novel; animal insurance exists in Germany as a State-aided institution. Certain States have liberally subscribed to the funds, and left it permissive for the farmer to join. Experience, however, shows that this is wrong, and that if this Institution is to flourish it must be obligatory for all to join for the general good, in order to avoid a drain on the resources of the State.

Nor are we ignorant of successful efforts to establish a mutual system of Insurance in this country. For many years past such a system has existed in Scotland. The Rhinns of Galloway Insurance Co., Ltd., was organized in 1872 to insure the farmers of that district against loss from cattle plague and pleuro-pneumonia.\* The rate payable was one shilling per head per annum for every animal insured; landlords subscribed at the rate of two shillings for every hundred pounds of rental, until an accumulated sum of £5,000 was obtained. It was decided by the

\* 'Cattle Insurance in the Rhinns of Galloway,' Mr. H. Ralston, *Transactions of the Highland and Agricultural Society*, 1890.

members there should be no dividend until the sum of £5,000 accumulated, and this amount was reached in twelve years.

Compensation was limited to three-fourths of the value of the animal, but after 1878, when local authorities were compelled to compensate for pleuro-pneumonia, the Company supplemented the amount paid by the local authorities, so as to give full value for all animals dying or being destroyed for this disease.

Before the State came to their aid, this system of mutual insurance enabled the Galloway farmers to control pleuro-pneumonia, and stamp it out as it from time to time occurred.

This example of the intelligent application of mutual help gives an idea of its possibilities, and points out how this principle may be extended against disease and accident amongst all classes of stock, and against all diseases, if only the nation were sufficiently provident. If we held the purse-strings, not a farthing of compensation would be given from public funds for any disease in any class of animal, until stock-owners generally combined for mutual protection and help.

The last question of compensation on which the Government has been urged to act is that of tuberculous meat seized as unfit for food.

Experience in Germany shows that this can be provided for completely among the trade, nor is an example wanting in this country, and once more it is taken from Scotland. At Paisley condemnation of carcasses was so frequent, that the persons interested, sixty-seven in number, formed themselves into a mutual protection society, and by a premium of threepence per head on bullocks, and sixpence per head on cows, sufficient funds were rendered available, to cover all loss through the condemnation of carcasses for tuberculosis.

The machinery for putting the scheme of mutual Insurance in motion, exists in the form of the numerous Agricultural Societies scattered throughout the Kingdom.

*SECTION III.—LANDING OF FOREIGN ANIMALS  
IN GREAT BRITAIN.*

One of the most beneficial Acts of Parliament relating to animals and agriculture ever passed, was the Amendment introduced in 1896 to the Diseases of Animals Act of 1894, by which the 24th Section of the Act of 1894 was repealed, which permitted the landing of animals alive in this country.

The Act of 1896 prohibited the landing of foreign cattle, sheep, goats, and swine, excepting for slaughter at the place of landing. Only those conversant with the historic animal plagues, can fully realize the extraordinary possibilities of this Order. It is the first step towards the eradication of epizootic diseases from Great Britain, for which our insular position is so favourable. So long as foreign cattle were being admitted, the stamping out of disease was an expensive procedure with no finality; for it was conceivable, as indeed actually occurred, that after freeing the country from disease we again allowed the importation of it. It is almost past belief, and entirely past understanding, how such a policy could have been adopted.

The bitter lessons learned in this respect have been purchased at an unnecessary cost, and any Government that yields to outside pressure to open this country again to infection from without, will be guilty of national suicide.

The restrictions on the importation of foreign animals are contained in the

*Foreign Animals Order of 1903.*

This order prohibits the landing of animals, even for destruction, from certain prohibited countries, which are issued in the schedule to the Order. It prohibits the landing excepting for slaughter of all animals (horses excepted) from any foreign country; or the landing of any carcase that has died or been slaughtered on board during the passage to this country; further it prohibits the landing of the manure, partly consumed or broken fodder, or litter of such animal; or any

fittings, pens, utensils, etc., used about such animal unless by the permission of the Board, and only then if the same has been disinfected by being scoured with water and sprinkled\* with a solution of carbolic acid lime-wash.

Anything landed in contravention of this article is to be seized by the Customs Authorities, and the facts reported.

The conditions regarding the landing of animals are very clear. The vessels carrying the animals must not within twenty-eight days before taking them on board, have had on board any animal from a prohibited country; further the vessel itself must not within twenty-one days of receiving her cargo of animals, or at any time since taking them on board, have entered or been in any port of a prohibited country, and the animals imported must not while on board have been in contact with any animal exported from any port or place in a prohibited country.

Before the animals are landed, the master of the vessel must deliver to the Customs Authorities a signed declaration that all the animals imported are properly imported in accordance with the provisions just stated.

The landing is effected at the Foreign Animals Wharf,† and from that time the animals are under the Inspector of the Board of Agriculture; they are driven by lairage men to the nearest available reception lair, and there examined by the above officer. If found free from disease the animals may be moved into other lairs of the Foreign Animals Wharf, as the Inspector shall direct or permit.

The only authorized persons permitted to be present during the landing operations, and to enter upon the landing stage or any part of the wharf used as a reception lair, are the Inspector of the Board, the officers of the Customs, the Superintendent of the wharf, and the lairage men; all others require the authority of the Inspector in writing.

Overall clothing and leggings must be worn by all during the landing of animals, and on leaving the wharf or reception lair the overall clothing is to be removed, the hands washed with soap and water, and the boots disinfected. The overall clothing is not removed from the wharf until disinfected.

A notice may be affixed to the entrance of any building or wharf, forbidding persons to enter without permission; to enter without

---

\* 'Sprinkled' is the term employed in the Act. For the purpose of disinfection sprinkling is of no use.

† Foreign Animals Wharfs are situated at the following Ports:

Bristol.	Hull.	Manchester.
Cardiff.	Liverpool.	Newcastle-on-Tyne.
Glasgow.	London.	Southampton.

permission constitutes an offence. Any person may be directed to quit the wharf, landing-stage, lair, or any building ; failure to comply is an offence.

If the Inspector of the Board finds that disease exists among the animals in the reception lair, or other part of the wharf, all the animals shall be detained, or moved to such other part as he may permit, and then dealt with in accordance with instructions given by him.

When animals are landed the market authorities are responsible for the supply of food and water until the owners take charge of them, and the market authorities may take action against any omission in this respect on the part of the owners.

All animals shall be slaughtered within ten days after landing ; the slaughter may begin at any time after landing as the Inspector may direct.

No carcase, dung, offal, litter, or manure can be removed from a Foreign Animals Wharf without the permission of the Inspector, and if in his opinion any such carcase or thing may introduce disease, the same shall be destroyed ; offal or dung under any circumstance must be disinfected before removal.

Fittings of the vessel, pens, hurdles, utensils, etc., which have been landed cannot be removed until scraped, scoured with water, and sprinkled with a solution of carbolic acid and lime-wash, and then only with the authority of the Inspector. Anything which in his opinion may introduce disease is to be destroyed.

An Inspector of the Board may require the disinfection and cleansing of any part of the wharf by the market authorities, and such must be done to the satisfaction of the Inspector.

No animals other than foreign can at any time be landed or moved into the Foreign Animals Wharf, and any animal found in this wharf is treated as a foreign animal.

In the Foreign Animals Order is a chapter dealing with the landing, disinfection and disposal of dung, fodder, litter, fittings and other things belonging to foreign animals, other than those landed at a Foreign Animals Wharf. This does not differ in any important particular from the Regulations on the subject laid down for animals landed at a Foreign Animals Wharf, excepting where consent is required the local authorities of the district are the responsible officials.

The above chapter would appear to be especially applicable to the landing of horses, mules, and asses, from foreign countries, for in a subsequent chapter power is given the Principal Officer of Customs to seize any of the above animals, fodder, litter, dung, and other thing, if it appears to him disease may thereby be introduced ; the same officer is then to report to the Commissioners of Customs, who may order

the destruction or detention of the same or their delivery to the owner.

(There is nothing in this chapter to show how the Principal Officer of Customs arrives at the conclusion that the animals are diseased. Presumably there is a Veterinary Inspector for the Port, but he does not appear in the order.)

*The Channel Islands Animals Order of 1896.*

This permits animals from the Channel Islands to be landed at any part of a port, that may be for the time specified as a Landing-Place for Channel Islands animals, without these animals being subject to slaughter or quarantine.

Restrictions are placed on the vessel not having carried foreign animals for 21 days previously, or not having been for 21 days previously in a port of a scheduled country; while the animals themselves must not while on board have been in contact with any animal carried from any country outside the United Kingdom, Channel Islands, or Isle of Man.

To insure these regulations being observed, no animals can be landed until the owner of the vessel has entered into a bond with the State, in a sum of one thousand pounds; and until the master of the vessel has made a declaration that all the animals are properly imported according to the above provisions.

On landing a twelve hours' detention is required, at the end of which time the animals are inspected by an officer of the Board; if found free from disease they may be moved from the landing-place, and they then no longer constitute foreign animals.

If cattle plague or foot and mouth disease is found to exist, all the animals are to be destroyed. If any disease other than cattle plague or foot and mouth disease is found, the Inspector shall cause all animals of the same kind as the diseased animal, which were brought in the same vessel, to be destroyed.

Power is given the Inspector to detain for any period he thinks proper any animal landed under this Order, if he suspects it to be diseased, or that it may introduce disease.

No animal, carcasses, fodder, litter, dung, or manure shall be removed from a landing-place, lair, or other place except by permission of an Inspector of the Board. If an Inspector of the Board is of opinion that any such animal or thing may introduce disease it shall be destroyed, or otherwise dealt with.

Fittings, pens, hurdles, utensils, etc., cannot be landed until cleansed and disinfected, and then only by permission; while the Inspector may cause them to be destroyed if he considers they may introduce disease.

No animal other than animals landed under this Order, can be landed at or kept in a landing-place.

Persons are prohibited from entering a landing-place, and a notice to that effect is to be affixed at the entrance; any person may be directed to quit such landing-place, lair, quay, etc., and failure to do so, or to enter without permission, is an offence.

All persons entering or leaving a landing-place are required to disinfect themselves and their clothes.

*Isle of Man Animals Order of 1896.*

This admits of animals, brought from the Isle of Man, being landed in Great Britain without being subject to slaughter or quarantine.

There are no regulations laid down for inspection on landing, but the Principal Officer of Customs is empowered to seize any animal, horse, ass, or mule, brought from the Isle of Man, or any carcase, fodder, litter, or dung, that he considers may introduce disease, while the Commissioners of Customs may order their destruction or detention.

*Foreign Animals (Quarantine) Order of 1896.*

This Order admits of foreign animals intended for reshipment to a foreign country, or for purpose of exhibition, or for other exceptional purpose, being landed with the permission of the Board, and placed in a quarantine station to be defined by a Special Order.

This Order is of such very limited application, that its conditions are not of general interest.

*SECTION IV.—THE PRODUCTION OF CALF  
VACCINE LYMPH.\**

*Calves.*—Either bulls or heifers may be used, the latter having the advantage that when on the operating-table the urine is not voided over the abdomen. The most suitable age is from 3 to 6 months, at which time they are of convenient size for easy manipulation, not likely to have contracted a natural vaccinia previous to operation, or to be found tubercular on post-mortem examination. It is this latter consideration which is the main argument for

\* This Section is from the pen of Major Butler, A.V.D., Army Vaccine Institute, Aldershot, to whom I am greatly indebted.

using youthful vaccinifers, since it is well known that tubercular infection of young stock is of rare occurrence though it is exceedingly common in adults. White and red and white animals are to be preferred to those with black skins, but only with the object of avoiding a dark coloration of the resulting lymph.

*Preparation of the Vaccinifer.*—The animal is secured on a tilting table in the position shown in Fig. 190. The upper hind-leg being either held by an assistant, as in the illustration, or secured to a suitable prop fixed to the table. The vaccination area is then shaved, thoroughly cleansed, and dried.

*Vaccination.*—The area vaccinated by different operators varies considerably; whilst some utilize the inside of the thigh, the scrotum, udder, and neighbouring parts, others consider that vesicles in these situations become too advanced, and employ only the more forward parts of the abdomen and sides of the chest. The methods of operation adopted also vary, some scarifying small patches with criss-cross lines, others merely making a series of long or short incisions about  $\frac{3}{4}$  inch apart over the selected area (Fig. 191). Whichever mode be adopted the incisions should be deep enough to admit of a thorough infection, but not so severe as to produce any pronounced bleeding. Into each incision is rubbed a sufficient quantity of a previously prepared vaccine, which should have been stored for a considerable time, and the operation is complete.

*Collection of Lymph.*—The lymph is usually collected 120 hours (5 days) after vaccination (Fig. 191), and this is generally considered the most suitable time, although 3 and 4 day lymph will also give good results, and is sometimes utilized. The calf having been secured on the table as before, is again thoroughly cleansed, and the vesicles (incisions) are then scraped with a sharp spoon; in the case of scarified patches or short incisions, each may be clamped previous to being scraped, but this does not appear to be essential, so long as the deeper portions of the vesicles are secured. The object of the clamping is to cut off the blood





Fig. 190.—Showing method of securing calf for operation.



Fig. 191.—Appearance of Vesicles produced by linear incision—120 hours.

*To jacc p. 644.*



supply, and so keep the collected lymph and pulp as free as possible from blood.

The point of importance is to know when a vesicle (inoculated area) is fit to collect from. On no account should anything be taken from it if it is advanced, viz., if there is the least sign of suppuration.

*Preparation after Collection.*—The material resulting from the collection, is triturated in a special machine to the consistence of a cream with a suitable proportion of glycerin and water, and this mixture is kept for a considerable time before issue.

Throughout the above operations, it goes without saying that the strictest surgical cleanliness should be observed in general and in detail, but the employment of antiseptics, advocated by some, should be avoided as far as possible owing to the danger of sterilizing the lymph itself. A free use of ethereal soap and boiled water, combined with the employment of an autoclave, and the precautions known to all surgeons regarding general and personal cleanliness, suffice to insure perfect results.

*Glycerinated Lymph.*—The admixture of glycerin with vaccine lymph in order to produce an easily manipulated pulp has long been practised, and Warlomont ('Manual of Animal Vaccination') credits the Vaccination Committee of Milan with being the first to establish the method. A modification, viz., glycerin and water, was introduced by him into Holland, and in this country it has been practised at the Army Vaccine Institute since 1889. In 1892 St. Yves Ménard and Chambon (Paris) noted that storage of lymph with glycerin for a considerable time gave most excellent results, but it remained for Monckton Copeman to demonstrate (1892) the reason for this, by proving that storage with glycerin killed or inhibited the growth of the extraneous organisms found in the lymph.

Since then the matter has received considerable attention, and it is now clearly shown that storage of calf lymph with a 50 per cent. solution of glycerin and water, produces at the end of a month or six weeks a vaccine practically free

from extraneous organisms (Figs. 192, 193), but retaining its virulence and protective properties intact. Further, it is now also established that the intense inflammation of the vaccination area, which was so prominent a feature in the past, was to a great extent due to those organisms, which by the glycerine method are eliminated.

It has also recently been demonstrated (Dr. Alan Green), that these organisms may be rapidly got rid of by the judicious use of chloroform vapour, and that when necessary large quantities of lymph may be thereby rapidly rendered suitable for use immediately after collection. Many varieties of extraneous organisms are present in all lymphs, but those which are specially alluded to are the *Staphylococci aureus*, *albus*, and *cereus albus*, being the varieties most commonly seen; the other organisms found, being quite innocuous, may be left out of the question.

The employment of calf vaccine lymph is becoming more general every year, and, indeed, this is not to be wondered at, as apart from the efficient protection from small-pox which it confers, one makes certain that all risk of conveying vaccino-syphilis or tuberculosis is avoided; the first disease does not exist among animals, and the second can be detected by the use of tuberculin and by post-mortem examination. It is, however, a very rare condition in calves.

The results of vaccination and re-vaccination with calf lymph show a very high percentage of success, the most recent statistics published giving a case success of 98·2 per cent. and an insertion success of 93·7 per cent. for about 750,000 vaccinations, of which 525,000 were primary and 225,000 were re-vaccinations.

The protection afforded may be best illustrated by our Army and Navy, both of which services are supplied with calf lymph, and although necessarily exposed as much as or more than other members of the community to small-pox infection, are free from the disease.

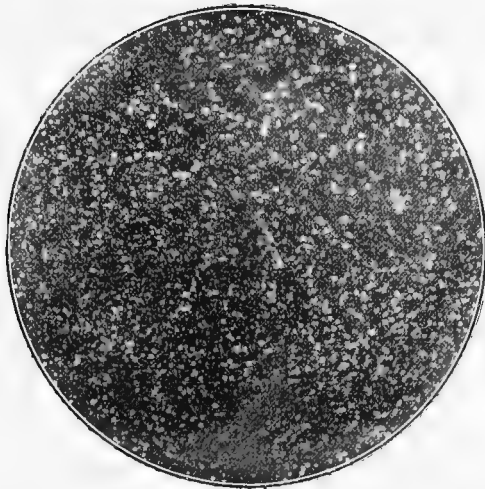

Fig. 192.—Appearance of agar-agar plate inoculated with one loopful of glycerinated lymph at the time of admixture, and subsequently incubated 48 hours.



Fig. 193.—Agar-agar plate inoculated from the same lymph and under the same conditions as that shown in Fig. 192 after 3 weeks' storage with glycerine.

*To face p. 046.*



## CHAPTER XII

### MUNICIPAL HYGIENE

It is only within the last few years that the function of the Veterinary Surgeon in Municipal Hygiene has received any recognition; even at the present time it is a mere germ compared to its prospective developments. The time must come, and that very shortly, when the Veterinary Officer of Health and his Assistants will be recognised as an integral part of every Municipal organization. We propose to consider in this chapter an outline of his duties, which may here be classified :

1. The veterinary care, entire management, and control of all horses the property of the Municipality.

As head of the Stable Department of the Municipality he should be charged with the buying of all horses, provender, and stable requisites; be held responsible for all expenditure, regulate the amount and character of the food, supervise the shoeing of the stud, and have control including the engagement and dismissal, of all subordinates; in fact, as the official head of a department, he should be saddled with the entire responsibility of its management and absolute efficiency.

2. The inspection of all cow-houses and dairy stock.

As Dairy Inspector he should be responsible for the carrying out of the law on the matter of water-supply, light, drainage, ventilation, cubic space, flooring, and general cleanliness of the cow-house and its surroundings; also for the thorough inspection of dairy stock, the detec-

tion of disease, the prohibition of the use of milk of those suffering from disease, with their compulsory removal if he considers necessary, and the general cleanliness of the cows.

3. The inspection of animals under the Diseases of Animals Act.

Combined with the examination of animals affected or suspected of being affected with a scheduled contagious disease, the Veterinary Inspector's duties include the inspection of Markets and Sale-Yards for animals of all kinds, and the entire responsibility for the efficient disinfection of these places rests with him. Likewise under his supervision should come the inspection of Knackeries, disposal of the dead, and registration of deaths.

4. The inspection of animals before and after slaughter for the purpose of food.

As Meat Inspector he must be responsible for the examination of meat as to its freedom from disease, with full powers to pass or reject, and possess complete administrative powers in connection with Public Abattoirs.

In some of his work he meets the Medical Officer of Health as a colleague, but not a subordinate. In the following pages every effort has been made to define where the responsibility of the one ends and the other begins.

In all matters of Reports the Veterinary Officer of Health should deal direct with the administrative head of the Department concerned, or with the Committees connected with the particular branch for which he is responsible.

#### MEAT INSPECTION.

The Royal Commission appointed to inquire into the danger to man through the use of tuberculous meat, went very carefully into the question of meat inspection in the United Kingdom. They pointed out that under the Public Health Act, 1875, and the Acts incorporated with it, the powers of inspecting and examining any animal, carcase, or meat for sale, falls to the Medical Officer of Health or



Inspector of Nuisances.\* Either of these officials may enter and inspect any place in the district used for the sale of meat, or slaughtering of cattle, and examine any cattle or carcase of any cattle.

The law in England did not contemplate, or rather the interested persons who drafted the Act, did not intend to contemplate a veterinary inspection of meat; excepting in Manchester and Swansea, both of which hold special and recent Parliamentary powers, the veterinary surgeon can only be a Meat Inspector if he be a Medical Officer of Health, or an Inspector of Nuisances.

Under the Public Health (Scotland) Act, 1897, a veterinary surgeon is approved as a meat inspector, and no medical officer or sanitary inspector can examine a living animal in connection with meat inspection, unless accompanied by a veterinary surgeon.

Under the same Act, provision exists which enables local authorities to appoint a place where an animal alive or dead may be inspected by a veterinary surgeon, and passed or condemned as the case may be. A certificate granted by a veterinary surgeon under these conditions exempts the owner from penalty should the meat be subsequently seized. But one very important clause in this Act, is that

\* Section 189 of the Public Health Act, 1875, requires every Urban Sanitary Authority to appoint a Medical Officer of Health, a Surveyor, and an Inspector of Nuisances.

A Rural Sanitary Authority is not compelled to appoint a Surveyor, but must appoint both the other officers.

The above Act does not recognise the designation Sanitary Inspector, the official designation is Inspector of Nuisances. The Public Health (London) Act, 1891, does recognise the title of Sanitary Inspector. The same Act requires the appointment of one or more Medical Officers of Health for the district of each Sanitary Authority, and an adequate number of fit and proper persons as Sanitary Inspectors. All the latter appointed in London since 1895, must be in possession of a certificate of such body as the Local Government Board may approve. This certificate in London is granted by the Conjoint Board.

Outside the Metropolis the Inspector of Nuisances requires no qualification, though the Sanitary Institute holds examinations in the Provinces for those desirous of obtaining its certificate.

'no carcase shall be submitted for examination, unless as a whole carcase, including the thoracic and abdominal viscera, in such a manner that the examiner shall be readily able to satisfy himself that the organs are those of the carcase under inspection.'

The Act does not contemplate under this scheme the inspection of dressed carcasses or parts of carcasses, for if these were admitted, there is nothing to prevent animals which have been killed on the point of death, or actually died from disease, from being submitted to examination and a protecting certificate obtained.

A very great trust is, therefore, imposed by the law of Scotland on the veterinary surgeon, and an enlightened view taken of his professional duties and qualifications.

In Ireland the law is the same as in England.

Meat inspection in England, with but few exceptions, of which Manchester stands pre-eminent, is an absolute farce.

In evidence before the Tuberculosis Commission, it was elicited that in Battersea four plumbers and three carpenters discharged these duties; in Hackney two plumbers, one carpenter, one compositor, one bricklayer, one florist, one builder, one surveyor, and one stonemason. In Portsmouth one butcher, three school teachers, one medical dispenser, one carpenter, and one tram-conductor! In fact men are appointed to these duties without any special training, or at the outside a smattering imparted by a short course of lectures and a hurried visit to an abattoir.

The training of meat inspectors should be carried out by the veterinary profession, and certificates of competence to subordinate meat inspectors should be granted under the authority of the Royal College of Veterinary Surgeons.

The inspection of meat before it leaves the abattoir should be purely veterinary; there is no one more ignorant of the symptoms, diseases, and post-mortem appearances of animals than the ordinary medical man, and this is said in no sense of disparagement; they are as awkward at this work as we should be at the bedside. In the veterinary inspection of meat all we should certify to is that the flesh

is healthy ; beyond that we should not attempt to go. If in the judgment of the medical officer it is unfit for human consumption, that is his side of the question on which we may be permitted to differ in private but not officially, for our interference with his work would be as intolerable as his with ours. Further, it is quite possible that meat passed as healthy before leaving the abattoir, may be unfit for consumption a few days later.

Assuming the public abattoir system were generally established, the veterinary voice should not be heard outside the abattoir, for the matter then belongs to the medical officer ; while neither during the life of the animal, nor during the abattoir inspection, should the voice of the medical officer be heard inside.

In no other way is it possible to avoid friction, or attempts at dual control. We must be as paramount where the animal is concerned, as the medical officer is where man is concerned. We are both in our distinct spheres guardians of the public health.

Many of the troubles arising from meat inspection are due to want of uniformity in rejection. In Belfast and Dublin medical inspection of tuberculous meat drove the butchers to private slaughter-houses. In Islington and Manchester seizure was only adopted for generalized tuberculosis, and at both these places skilled veterinary opinion was found to be in conformity with common-sense, and the subsequent opinion of the Tuberculosis Commission.

All engaged in the cattle and butchering trade bitterly complain of this want of uniformity, which is defeating its own ends, and driving from public abattoirs the very people whose opposition to anything new it is most undesirable should be intensified by unfair treatment. It is common-sense for these traders to ask for a recognised standard to be established and universally maintained, so that the absurdity of meat being passed by one inspector and rejected by another should not be able to occur.

As the Commission expressed it: 'Chaos is the only

word to express the absence of system in the inspection and seizure of tuberculous meat. . . .'

The inspection of meat should be thorough but fair, that is to say, some universal standard should as far as possible be laid down for the guidance of meat inspectors, but little left to their opinion, and nothing to their individual caprice; in this way all connected with the live and dead meat trade would know exactly how they stand.

In fairness to the British agriculturist and tradesman, the inspection of foreign meat whether landed alive or dead, should be as searching as that of home production. We recognise the difficulties in the examination of dead meat owing to the absence of the viscera, so that the conditions for imported dead meat should in consequence be more rigid.

We have touched on the question of the ordinary meat inspector as appointed by local authorities, and drawn attention to the ridiculous situation created, of men belonging to any odd calling being appointed to do work essentially the duty of a pathological expert. An attempt was made on the publication of the finding of the Tuberculosis Commission, to at once meet their recommendations by training Inspectors of Nuisances, and others similarly qualified, to take up a specialized line of study. These meat inspectors were put through a hurried course of a few days' instruction, in a syllabus which if carefully followed would take eighteen months to two years; imperfectly prepared material has been poured forth ever since supposed to be capable of examining animals both alive and dead.

We recognise everything must have a beginning, but the initial mistake made in the training of inspectors, was that it was not done by the veterinary authorities who do know, but by the medical authorities who do not know. It is a farce to talk of meat inspectors trained by means of a few wet preparations, diagrams, models, and a visit to an abattoir. Not a single qualification of meat inspectorship should be granted, excepting such persons have previously

been practically trained by the veterinary profession in the lair and abattoir.

All important and responsible positions as meat inspectors should be filled by veterinary surgeons, and only the minor positions or assistant inspectorships should be held by the subordinates they have trained.

It is interesting to note that the Royal Commission were careful to avoid committing themselves, as to who should be the authority to grant qualifications for meat inspectors. They left it to the Local Government Board or Board of Agriculture to prescribe the authority, and the Local Government Board appears to have nominated themselves. In a circular letter to local authorities they draw their attention to the qualifications of a meat inspector as laid down by the Royal Commission, and suggest that no inspector of nuisances be appointed to that office who has not the meat inspector's qualifications.

At the present time two sanitary bodies are endeavouring to remove the reproach from this country, the birth-place of sanitary science, by instituting some instruction in meat inspection and examination of inspectors.

This, however, will not suffice, neither in the interests of economy nor efficiency is it right to combine meat inspection with drains and effluvia; those who advocate this course have failed to realize this work is that of an expert, and that efficient meat inspection in any town or city, leaves no time for dealing with defective drains or nuisances.

The Tenth International Congress of Hygiene adopted a resolution that meat inspection could only be efficiently carried out by veterinary surgeons; with that opinion none will disagree who know the real facts of the case, the responsibilities involved, and the technical knowledge required.

The Royal Commission recommended that in every district where a public slaughter-house exists, every slaughtered carcase brought into the district should be inspected, unless there is evidence of it having been inspected and passed in the public abattoir of another authority.

The object of this recommendation was to insure the

inspection of meat, which is intentionally prepared outside the district in which a public abattoir is situated.

The marking of foreign meat as evidence of its inspection at the time of slaughter was also recommended, and that steps should be taken through the proper channel to ascertain that efficient inspection at foreign slaughter-houses takes place, of meat intended for consumption in this country.

The wisdom of this step is obvious, it is no use having a rigorous home inspection and letting in foreign meat without any examination. It must be borne in mind that such an inspection on landing must necessarily be very crude and imperfect, and the onus of a complete examination should be placed on the shoulders of the country which supplies the material.

#### *Slaughter-houses.*

We do not intend discussing whether a slaughter-house should be a private concern or the property of the public, for the reason that private slaughter-houses are absolutely unjustifiable, and a serious danger to the public health. Still they exist, and it is desirable to inquire into the conditions which attach to them.

All private slaughter-houses in urban districts in England and Wales are either Registered or Licensed. By the former is meant a house which was in existence when the Towns Improvement Clauses Act of 1847 was applied; by Licensed houses is understood those which have come into existence since that period, and of which the license is renewed annually or otherwise.

A Registered house which sells unsound or diseased meat, cannot be touched by any local authority for having done so, unless the occupier is the owner or proprietor; a Licensed house can be permanently closed after two convictions of the occupier.

By the system of license, it is within the power of all local authorities to reduce the number of slaughter-houses

in their area, and if steadily enforced the system of public abattoirs for all towns and cities would be gradually introduced.

The greatest difficulty has been experienced in educating the public mind to the necessity of public abattoirs, and private vested interests in this, as in everything else, have had primary consideration. Still, Glasgow is an example of what can be overcome by steady persistence. The municipality of this enlightened city erected public abattoirs forty years before they obtained the needful powers to enforce their use, and suppress private establishments.

Scotland has in the matter of slaughter-houses and meat inspection been far ahead of the times. For instance, she refuses to recognise any distinction between houses registered or licensed, they are treated alike, and both have to take out a license annually.

Further, and this is of the utmost importance, no private slaughter-houses of any kind are permitted to exist in any Burgh in Scotland once a public abattoir has been provided. In this way, in the immense city of Glasgow and the city of Edinburgh, not a single private slaughter-house exists!

In Ireland the private slaughter-house exists, and both at Belfast and Dublin, where public abattoirs are available, every possible means is adopted of evading the system of meat inspection which a public abattoir insists on. In the case of Belfast, private slaughter-houses were erected outside the municipal boundary; while in the case of Dublin the abattoir for the City having been accidentally built a few feet outside the municipal boundary, could only be brought within the boundary by the Dublin Corporation Act, 1890, at the expense of permanent licenses being granted to all slaughter-houses then holding temporary licenses, so that in future compensation would be necessary before these could be closed.

Thus, as the Royal Commission on Tuberculosis pointed out, a fine public abattoir, the best in the United Kingdom, is rendered comparatively useless. It would appear from the reports of the Commissioners that the chief fault to

find with existing public abattoirs is that, excepting in Dublin, the arrangements for efficient inspection and lighting are defective. The principle to be observed in a public abattoir is that the destruction of animals should take place in one common large well-lighted hall, and not in a series of separate chambers, as in this country, where the offal of several animals get impossibly mixed, and the lighting is so defective as to impair the value of inspection.

As the case of public abattoirs in this country at present stands, local authorities may under the Public Health Act, 1875, provide public slaughter-houses but cannot insist on their being used. How far the local authorities have availed themselves of their powers, may be judged by the fact that out of 1,083 towns in England, only 84 public abattoirs exist, and many of these are but little used, while London has six hundred private slaughter-houses and not one public abattoir available for general use.\*

There are certain conditions a public, or for that matter any, slaughter-house should comply with. It is not an institution which should be placed in the middle of a town, and yet it must not be so far away as to cause extra expense to those who use it.

The general arrangement and details of the building must depend upon the size of the town or city, but full information on this and allied subjects may be obtained by reference to the work above quoted. The general principles involved are as follows :

A separate drainage system is required for the killing-rooms, so as to avoid blood, fat, and excreta finding its way into the general sewerage system of the town.

The abattoir buildings must provide lairage for all animals, in order that rest before slaughter may be given them. The meat of animals killed in a state of fatigue is inferior and keeps badly.

The actual killing-place should be a large, well-lighted,

\* 'Public Abattoirs and Cattle Markets': Dr. O. Schwarz. Translated by Messrs. Harrap and Douglas.



well-ventilated central hall, where inspections can be made under satisfactory conditions ; no overcrowding should be permitted, and system and discipline must be maintained. Electric lighting should be provided, as it is in every way superior to gas.

The floor of this building must be water-tight, and if possible not slippery ; it should slope towards open gutters, and no other system than surface drainage should be permitted within the building, both traps and gutters being non-existent.

The walls must be impervious to moisture for at least six feet above the level of the floor, smooth and easily cleaned. An ample water-supply should be laid on for this purpose, for the most thorough cleanliness of flooring and walls is an absolute necessity.

An incinerator should form an essential part of every abattoir ; it should be so constructed that diseased tissues or carcasses can be destroyed, also all offal or refuse which cannot be utilized, even the ingesta if no sale can be had for it.

Among the essentials of a public abattoir are chambers where the meat can hang and properly set, and further, cold rooms where it may be kept until required. The air of the setting chambers must be both fresh and dry, and in consequence this part of the building should not communicate with the slaughtering hall or the cattle lairs.

The important question to the public is who should be the Superintendent of a Public Abattoir ? This matter has been settled, at any rate in most of the German states, in favour of the Veterinary Surgeon, who, with the status of Sanitary Veterinary Officer, has complete control over most of the principal abattoirs. His duties, besides those of administrator, comprise the inspection of all animals alive and after death.

In the United Kingdom two Veterinary Surgeons are employed as Superintendents of Abattoirs, with the full powers of Veterinary Officers of Health, viz., at Manchester and Glasgow.

## LEGISLATION.

Under Section 169, Public Health Act, 1875, with which is incorporated the Towns Improvement Clauses Act, 1847, urban authorities are authorized to regulate slaughter-houses within their district, and for this purpose to make byelaws for the licensing, registering, and inspection of the same; for preventing cruelty, keeping such places in a clean and proper state, removal of filth at least once in every twenty-four hours, and a sufficient water-supply; for neglect of any of these, penalties can be imposed.

The legislative difference between Registered and Licensed Slaughter-houses has already been defined.

The advice given to local authorities by the Local Government Board, as to the site and structure of private slaughter-houses, is as follows:

1. The premises to be erected or to be used and occupied as a slaughter-house should not be within 100 feet of any dwelling-house; the site should be such as to admit of free ventilation by direct communication with the external air, on two sides at least of the slaughter-house.

2. Lairs for cattle in connection with the slaughter-house should not be within 100 feet of a dwelling-house.

3. The slaughter-house should not in any part be below the surface of the adjoining ground.

4. The approach to the slaughter-house should not be on an incline of more than one in four, and should not be through any dwelling-house or shop.

5. No room or loft should be constructed over the slaughter-house.

6. The slaughter-house should be provided with an adequate tank or other proper receptacle for water, so placed that the bottom shall not be less than six feet above the level of the floor of the slaughter-house.

7. The slaughter-house should be provided with means of thorough ventilation.

8. The slaughter-house should be well paved with asphalt or concrete, and laid with proper slope and channel towards a gully, which should be properly trapped and covered with a grating, the bars of which should be not more than three-eighths of an inch apart.

Provision for the effectual drainage of the slaughter-house should also be made.

9. The surface of the walls in the interior of the slaughter-house should be covered with hard, smooth, impervious material to a sufficient height.

10. No watercloset, privy, or cesspool should be constructed within the slaughter-house.

There should be no direct communication between the slaughter-house and any stable, watercloset, privy, or cesspool.

11. Every lair for cattle in connection with the slaughter-house should be properly paved, drained, and ventilated.

No habitable room should be constructed over any lair.

A licence having been obtained to open a private slaughter-house, it has next to be registered, and then the following rules are suggested by the Local Government Board to apply to the management of such places :

7. Every occupier of a slaughter-house shall, at all reasonable times, afford free access to every part of the premises to the Medical Officer of Health, the Inspector of Nuisances, or the Surveyor of the Council, or to any Committee specially appointed by the Council in their behalf, for the purpose of inspecting such premises.

8. Every occupier of a slaughter-house shall cause every animal brought to such slaughter-house for the purpose of being slaughtered, and confined in any pound, stall, pen, or lair upon the premises previously to being slaughtered, to be provided during such confinement with a sufficient quantity of wholesome water.

9. Every occupier of a slaughter-house and every servant of such occupier and every other person employed upon the premises in the slaughtering of cattle shall, before proceeding to slaughter any bull, ox, cow, heifer, or steer, cause the head of such animal to be securely fastened so as to enable such animal to be felled with as little pain or suffering as practicable, and shall in the process of slaughtering any animal use such instruments and appliances, and adopt such method of slaughtering, and otherwise take such precautions as may be requisite to secure the infliction of as little pain or suffering as practicable.

10. Every occupier of a slaughter-house shall cause the means of ventilation provided in or in connection with such slaughter-house to be kept at all times in proper order and efficient action, so that the ventilation shall be by direct communication with the external air.

11. Every occupier of a slaughter-house shall cause the drainage provided in or in connection with such slaughter-house, to be kept at all times in proper order and efficient action.

12. Every occupier of a slaughter-house shall cause every part of the internal surface of the walls, and every part of the floor or pavement of such slaughter-house, to be kept at all times in good order and repair, so as to prevent the absorption therein of any blood or liquid refuse or filth which may be spilled or splashed thereon, or any offensive or noxious matter which may be deposited thereon or brought into contact therewith.

He shall cause every part of the internal surface above the floor or pavement of such slaughter-house to be thoroughly washed with hot

lime-wash at least four times in every year; that is to say, at least once during the periods between the first and tenth of March, the first and tenth of June, the first and tenth of September, and the first and tenth of December respectively.

He shall cause every part of the floor or pavement of such slaughter-house, and every part of the internal surface of every wall on which any blood or liquid refuse or filth may have been spilled or splashed, or with which any offensive or noxious matter may have been brought into contact during the process of slaughtering or dressing in such slaughter-house, to be thoroughly washed and cleansed within three hours after the completion of such slaughtering or dressing.

13. An occupier of a slaughter-house shall not at any time keep any dog, or cause or suffer any dog to be kept in such slaughter-house.

He shall not at any time keep, or cause or suffer to be kept in such slaughter-house any animal of which the flesh may be used for the food of man, unless such animal be so kept in preparation for the slaughtering thereof upon the premises.

He shall not at any time keep any cattle, or cause or suffer any cattle to be kept in such slaughter-house for a longer period than may be necessary for the purpose of preparing such cattle for the process of slaughtering.

If, at any time, he keep, or suffer to be kept in such slaughter-house any cattle for the purpose of preparation for the process of slaughtering, he shall not cause or suffer such cattle to be confined elsewhere than in the pounds, stalls, pens, or lairs provided on the premises.

14. Every occupier of a slaughter-house shall cause the hide or skin, fat, and offal of every animal slaughtered on the premises, to be removed therefrom within *twenty-four hours* after the completion of the slaughtering of such animal.

15. Every occupier of a slaughter-house shall cause the means of water-supply provided in or in connection with such slaughter-house to be kept, at all times, in proper order and efficient action, and shall provide for use on the premises a sufficient supply of water for the purpose of thoroughly washing and cleansing the floor or pavement, every part of the internal surface of every wall of such slaughter-house, and every vessel or receptacle which may be used for the collection and removal from such slaughter-house of any blood, manure, garbage, filth, or other refuse products of the slaughtering of any cattle or the dressing of any carcase on the premises.

16. Every occupier of a slaughter-house shall provide a sufficient number of vessels or receptacles, properly constructed of galvanized iron or other non-absorbent material, and furnished with closely-fitting covers, for the purpose of receiving and conveying from such slaughter-house all blood, manure, garbage, filth, or other refuse products of the slaughtering of any cattle or the dressing of any carcase on the premises.

He shall forthwith upon the completion of the slaughtering of any cattle or the dressing of any carcase in such slaughter-house cause such blood, manure, garbage, filth, or other refuse products to be collected and deposited in such vessels or receptacles, and shall cause all the contents of such vessels or receptacles to be removed from the premises at least once in every twenty-four hours.

He shall cause every such vessel or receptacle to be thoroughly cleansed immediately after such vessel or receptacle shall have been used for such collection and removal, and shall cause every such vessel or receptacle when not in actual use to be kept thoroughly clean.

#### *Methods of Slaughtering Animals.*

For years past the veterinary profession has been endeavouring to get some reform instituted in the direction of humane slaughtering; there is perhaps no one not connected with the trade who knows more of what goes on in an abattoir, and an endeavour has been made to educate the public to a sense of its responsibility in this matter. Up to the present the success has not been great, but the day must shortly arrive when it will be illegal throughout the country for any animal, great or small, to be killed without previously being rendered insensible by stunning.

In this and other matters connected with abattoirs they are ahead of us abroad. It is illegal in Saxony and Switzerland to slaughter without stunning, and, further, every means is taken to teach men the methods of becoming expert at this revolting business, by means of certain mechanism which will be found fully described in the reference given on p. 662.

Various forms of slaughter masks for the larger animals have been devised, some of which are ingenious but not always practical. In all cases they assume what is certainly very common, want of skill in the application of the most common and effective weapon, viz., the pole-axe. With the latter instrument stunning and brain destruction are effected at the same time, but the instrument requires skill and strength, and mishaps occur which the various masks are intended to prevent. The chief defect of the

mask appears to be the occasional difficulty of its application, and the alterations which occur in the bolt through use. The latter is capable of being remedied, but the former objection remains.

Shooting masks have been employed, but firearms in a crowded place are not without risk, and can never become popular.

The practice in this country is to stun the larger animals but not the smaller. As was pointed out by Hunting\* ox stunning was not carried out from humanitarian motives, but simply for the protection of the butcher from injury, while sheep were killed with the knife in a most cruel manner.

Whatever method of blood-letting is employed, the main principle should be that no cutting instrument should be used to any animal that was not already unconscious from a blow on the head. Holburn in his paper points out that the larger animals are not easily stunned on account of the anatomy of the skull, the structure of which enables the head of the animal to be its means of offence. This is all the stronger reason for not allowing any man to kill animals who is not certified to be properly trained and fit for his work.

The Jewish method of slaughter is generally regarded as cruel, and no doubt roughness is experienced in the preliminary casting. What amounts to very nearly decapitation must cause early loss of consciousness, and Holburn in comparing the Christian and Jewish methods considers from a point of hygiene the latter to be more commendable.

Animals so destroyed bleed better, and it is said *rigor mortis* sets in quicker and lasts longer than in the Christian method.

A Committee appointed by the Admiralty in 1904 to consider the 'Humane Slaughtering of Animals,' recommended that the Jewish system should not be permitted in any establishment under Government control, as the method

\* In the discussion on 'Slaughtering of Animals for Human Food': Mr. A. Holburn, M.R.C.V.S., *Congress Sanitary Institute*, 1903.

was not sufficiently rapid, or free from unnecessary pain, while loss of sensibility was not instantaneous.

There is no doubt it should be made obligatory throughout the country for all animals to be stunned before the knife is employed, and it certainly cannot be a problem outside mechanical skill to devise an arrangement for stunning an ox with one blow.

It appears to us that destruction of all animals by decapitation, on the principle of a guillotine, might be found practicable.

To find the right spot for the destruction of a brain two rules are given. One is a point which lies exactly halfway between the base of one horn and the opposite eye; the second is to draw a line from the root of each ear to the opposite eye, and where the two lines cross is the desired spot.

There are certain features in connection with the destruction of animals which require legislation. No person should be allowed to destroy animals who does not possess a certificate of qualification as a butcher, which certificate should be granted only by the local authorities.

Under no circumstances should any member of the public be admitted to an abattoir during working hours.

No person under eighteen should be permitted to be employed in any abattoir.

The steaming carcasses of freshly-killed sheep and pigs should not be exposed outside butchers shops to the gaze of the curious, especially children. The abolition of private slaughter-houses would get rid of this demoralizing sight.

#### *Inspection of Animals prior to Slaughter.*

This is an important part of any well-organized system of meat inspection. The animals intended for food are kept in suitable lairs in the abattoir, and rested after their journey. This is to insure that the flesh has an opportunity of recovering from the effects of fatigue, without which it would both bleed and set badly, and be tough.

Each animal is inspected to insure it is in health, and presents no obvious signs of disease. In questions of doubt the temperature should be taken. The expert's eye knows at once the least departure from health, a knowledge only obtained by long association with animals, and cannot be conveyed, as the layman generally considers, either by lectures or books.

At the ante-mortem inspection any doubtful point may be noted for careful post-mortem examination, such, for instance, as an enlarged jaw.

*Method of Meat Inspection.\**

We have previously drawn attention to the value of the central 'hall' system of abattoir over the Chamber system. Nowhere indeed is the advantage more felt than in the post-mortem inspection, where it is not only a time saving arrangement, but the carcase never being out of sight nothing can be removed by the butcher which he thinks would not stand inspection.

The following convenient system of inspection is suggested by McFadyean,† who lays stress upon the fact that the examination should be systematic, and conducted in some definite order so as to avoid overlooking anything of importance.

The skin should be examined for marks of bruising likely to damage the superficial muscles. In the case of a cow or heifer this is also the time to examine the udder, both its size and resistance. An incision should be made into each quarter, exposing the milk sinus and gland substance. A thorough examination of the gland for tuberculosis or any other form of mastitis should be made.

\* In the preparation of this section I have drawn freely on the late Professor Walley's 'Guide to Meat Inspection,' and have further had the advantage of having these pages revised by the Editor of the 4th Edition of that manual, Mr. S. Stockman, M.R.C.V.S., Chief Veterinary Officer to the Board of Agriculture.

† 'The Inspection of Animals intended for Food': Prof. McFadyean, B.Sc., M.R.C.V.S., *Proceedings National Veterinary Association*, 1893.



The abdominal cavity is then opened, and the escape of any serous or inflammatory fluid observed. The stomach and intestines are next removed, and the whole of the abdominal viscera exclusive of the kidneys.

The stomach and intestines should be felt with the hand for any tubercular deposits, and the former inspected within for evidence of inflammatory trouble.

The omentum, but particularly the mesenteric glands, should be examined for tuberculous deposits.

The liver and spleen should be cut into and the volume and colour of each noted. The bile-ducts should be examined for thickening or other evidence of fluke disease, while particular attention should be paid to the spleen, and in case of any marked departure from health the pulp should be examined for anthrax.

The kidneys may be examined *in situ* when the carcase is hanging, a longitudinal incision in each being made where there is reason to suspect tuberculosis, but not otherwise, or it may damage them for sale.

The pelvic organs in the female should be carefully looked at, the uterus opened and search made for portions of placenta, and any inflammatory or other fluid noted.

The chest should be opened and the organs examined *in situ* and then removed. The lungs should be thoroughly examined by the hand and then freely incised; deposits of any kind should be noted, and their nature determined. The presence of echinococcus cysts should be observed, and the state of the pulmonary pleura ascertained. The heart should be inspected for the presence of cysticerci or foreign bodies, and the whole of the costal pleura examined with the hand for any evidence of tubercular deposits.

The lymphatic glands of the chest, viz., the bronchial, also the prepectoral and suprasternal groups, should be carefully examined for evidence of tubercle by repeated sections.

The tongue, submaxillary and other glands of the region, should be inspected for evidence of actinomycosis.

In young animals a careful examination of the umbilicus

and liver must be made for any indication of septic inflammation or pyæmic disease. In pigs evidence of cysticerci should be sought in the muscle of the cheeks, diaphragm, tongue, heart, pectoral, intercostal, and neck muscles, while the vertebral column and sternum should be examined for tubercular disease. The examination for trichina is microscopical, the specimens selected being taken from the pillars of the diaphragm, abdominal, intercostal, and laryngeal muscles. The disease is so rare in this country that no routine examination is made. In Germany an army of inspectors is retained for the purpose, principally women, and payment is largely though not entirely by results. McFadyean tells us that in the Berlin abattoir alone the annual cost of inspection amounts to £25,000.

An examination of dressed carcasses sent for inspection without the viscera is nearly valueless, even if accompanied by the viscera there is no evidence they belong to the carcase under inspection. If an opinion on a dressed carcase is demanded, an examination of the peritoneal and pleural sacs, bone marrow, and all available lymphatic glands, should be made. A stripped pleura should at once condemn the whole, when the carcase has been sent in dressed without the organs, or in the case of foreign meat. In connection with this subject there are many carcasses which, with the permission of the Inspector, it might be allowable to strip for marketable purposes—for example, an echinococcus cyst on the periphery of the lung, or a local pleurisy, or a local and circumscribed abscess from injury.

In looking for evidence of septicæmia in the examination of a dressed carcase, a microscopical examination of the bone marrow is often of great value. The microbes of anthrax, swine erysipelas, and other septicæmic diseases, remain for a considerable time in a state of purity in the bones of the limbs.

The bones can be sterilized by boiling, and kept in an antiseptic solution for future reference, or for submission to an expert.

The muscles of such a carcase should be carefully exam-

ined ; the presence of blood in the larger vessels and decided discoloration of the muscular tissue, might mean the animal had died a natural death, or had only been killed at the point of death. Bruising of the surface of the body from the recumbent posture may be present, or evidence on the sternum and quarters of bruised tissue having been removed.

The smell of such flesh should be carefully noted for evidence of medicine, or signs of approaching decomposition or sourness. The best place to see muscular changes is between the ribs ; discoloration of the abdominal muscles would be evidence that the butcher had been called in late.

The condition of the flesh of a healthy animal slaughtered in the ordinary way, is best told after *rigor mortis* has set in. A freshly cut surface should be examined ; healthy muscle is red, brighter in the young animal, darker in the old ; the flesh is firm to the feel and not soft or sticky. There should be no blood in the larger vessels if bleeding has been properly conducted. The grain of the meat should be fine, it becomes coarser with age, and is markedly so in the cow and bull. A due proportion of fat should surround the muscles of the body, but none is seen in the muscles below the elbow or stifle.

The muscles of an animal which has been killed before recovering from the fatigue of a journey are darker in colour, sticky to the touch, the flesh 'sets' and keeps badly, and the meat is tough and difficult to digest.

Paleness of the muscular tissue indicates poverty ; a gelatinous exudate between the muscles, taking the place of the normal fat, is suggestive of advanced emaciation.

The smell of the flesh of the bovine should be sweet, free from all taint or mustiness. The flesh of the bull has a distinctive smell, is coarse, stringy, and darker in colour.

The muscles of an old cow are darker coloured and stringy, partaking more of the characteristic features of those of the bull. In the calf they are pale, and in very young animals, such as a foetus, both very pale and watery.

Calf flesh possesses a distinctive odour, and soon becomes sour by keeping.

In the ox the fat should be firm, varying from white to yellow, depending on age, diet, and occasionally on breed. It is whiter in young animals and such as are corn and grass fed; it is yellower in animals which are fed on cake, and it is naturally a deep yellow in the Jersey and Guernsey breed of cattle; it is also yellow in old cows.

In very young animals there may be an absence of fat, the fat area containing a gelatinous tissue; in the calf the fat resembles tallow.

The flesh of the horse is darker than that of the ox, and the fibres coarser; by keeping it soon contracts a sickly odour, and sticks to the fingers. The muscles of the horse contain glycogen, and in doubtful cases this may be looked for, though it would be unnecessary if any definite portion of the skeleton was present for identification.

To determine the presence of glycogen the suspected muscle must be extracted by boiling for half an hour, and the solution thus obtained cooled; after cooling dilute nitric acid is added and the solution filtered. To the filtrate is slowly added a saturated, hot, freshly prepared solution of iodine, which is allowed to trickle down the side of the test tube so as not to suddenly mix with the fluid under examination. At the junction of the two liquids a ring of colour, red to violet, is developed if glycogen be present.

The flesh of the sheep is less florid than that of the ox, and finer in the grain; the fat is white and very firm. In the ram the flesh is darker and tough.

The flesh of the goat is darker than that of the sheep, with less fat generally throughout the body, though the lumbar fat is much the same. The flavour and odour of this flesh is characteristic of the animal, and is more evident when it is heated.

The muscles of the pig are paler than those of herbivora, while the fat is soft and unctuous.

Meat for the sake of preservation or convenience of transport may be salted, frozen, or chilled.

It frequently happens, especially in hot weather, that the salting process is adopted to save meat which looks like not keeping. If meat is tainted before pickling, the salting process may save the exterior of the joint, but the tissues next the bone will still give evidence of the process. In doubtful cases the insertion of a skewer and smelling it on withdrawal should settle the point.

The difference between frozen and chilled meat is a question of temperature. The matter is of no interest to the veterinary inspector, who is only concerned with the question of the freedom of flesh from disease, and from what we have previously said the examination of a dressed carcase whether fresh, frozen, or chilled is of very little value. To the medical officer the question is of more importance, frozen quartered meat is not so nourishing as that which has been chilled, but this does not apply to carcasses frozen whole, where no loss of body fluid results from freezing.

The different characteristics which enable the carcase of one animal to be distinguished from another do not need to be taught to the veterinary inspector. When, however, the carcase of a bovine is quartered and the head removed, it becomes a question of some degree of nicety to determine whether the beef is bull, ox, or cow. The problems to be solved are identical with those demanded from the human surgeon for forensic purposes, when only a non-distinctive portion of a mutilated body is available for examination.

We shall confine our attention to practically the same points that he is called upon to determine, viz., sex and probable age.

The pelvic region and hind-quarters generally help the question of sex to be solved. In the bull there is a distinct tubercle on the anterior part of the symphysis pubis; this is smaller in the castrated animal, while in the cow it is poorly developed.

In the male the line of the symphysis is distinctly curved, in the female it is flatter.

In the bull the hind-quarters are well developed, less so

in the bullock, still less in the female, while in the cow the posterior line of the quarters is distinctly concave.

The pelvis is broader in the female than the male, and the diameter of the pelvic brim is greater.

The question of age in the bovine, may be assisted by the fact that up to the age of three it is possible to cut through the pelvic symphysis with the knife; up to the age of four years the costal cartilage of the ninth rib can be cut with comparative ease, at five years it is difficult, and at six impossible.

The junction between the summits of the dorsal vertebræ and the processes themselves are cartilaginous up to the sixth year, and even up to the eighth year a thin layer of cartilage may be seen in the first four or five vertebræ; up to the twelfth year the separation is represented by a red line, which after this disappears.

#### *Pathological Changes which Render Flesh Unfit for Food.*

This is at times rather a difficult subject, as no hard-and-fast lines can be drawn. Two animals might be affected with the same disease; take for example distomatosis in the sheep, one might be quite fit for consumption, the other unfit, the difference in the two depending upon the freedom or not of the muscular tissue from the general anæmic changes.

So with a pleurisy of traumatic origin, one case might be passed another rejected as food, depending on the period which has elapsed since the injury occurred, and whether the wound is aseptic or no. If the animals were destroyed before febrile changes took place no exception could be taken to the flesh; if some days have been allowed to elapse, and should perforation of the chest via the œsophagus have taken place, the flesh is often quite unfit owing to febrile and other disturbances.

These two broad rules govern the majority of cases; what is known as 'fevered flesh' may be met with in any disease where a high temperature exists, quite irrespective of the nature of the disease.

'Fevered flesh' is generally dark from defective bleeding, but not always so; it is soapy to the touch, sets badly as a rule, and is quite unfit for food.

Such a condition of flesh may be met with in any inflammatory disease, and if the animal has received medical treatment the drugs may be recognised by their smell in the flesh; in this way ether, turpentine, carbolic acid, camphor, etc., may give a characteristic smell, while severe purgation may render the muscles soft and watery.

Acute lesions may exist locally, the effect of which does not extend to the other muscles of the body. For instance, there may be extensive muscle injury where it is sufficient to remove the discoloured portion; or an encysted cold abscess, the entire removal of which is all that is required. On the other hand, extensive suppurations or gangrene necessitate the seizure of the whole carcase.

It is safe as a rule to say that acute inflammation of the viscera, especially involving serous membranes, causes the flesh to be unfit for food, rendering it dark, soapy, and oedematous, and specially prone to putrefaction.

Septic troubles like those associated with the parturient animal, render the flesh repulsive and utterly unfit.

Anthrax and quarter-evil flesh has been consumed without harm resulting, but should invariably be seized and destroyed.

The flesh in pleuro-pneumonia and foot and mouth disease has been consumed in the early stage of the affection, especially the latter.

In mammitis the entire removal of the gland and all lymphatics of the region is sufficient; the flesh if otherwise good may pass; but if an animal be killed during the acute stage of ordinary mammitis, it is possible the meat will be unfit for consumption owing to its being 'fevered.'

In bacterial necrosis of the liver of cattle and sheep, it is sufficient to seize the affected organ. The flesh is quite fit for food. If in any liver disease associated with jaundice,

the muscular tissues are stained yellow, condemnation of the carcase should follow.

Exception is frequently taken to the carcases of animals destroyed for milk-fever. There is no reason why, if killed early in the disease, at a time when they can be properly bled, and before they are saturated with medicine, they should not be used; the flesh is quite sound and good. Later on it is quite another matter, if destroyed *in extremis* the above objections exist, and the idea is repulsive. This is a very frequent class of case, and if any bruising of the brisket or hips exist with a badly-bled carcase, it is almost positive the animal has been destroyed on the point of death and the carcase should be rejected.

Tuberculosis, as we shall see presently, is the most common cause of meat being seized, and the preponderance of dairy stock affected over every other class of bovine will then be alluded to. The question which we have here to consider is the important one of determining what amount of tuberculosis may be present in a carcase, consistent with the safety of the consumer. In other words, when should a carcase affected with tuberculosis be accepted and when rejected?

The danger of infection from tuberculous meat has been greatly exaggerated. The veterinary profession in the person of McFadyean was the first in this country to point out that total seizure of every tuberculous carcase was not only unnecessary, but a waste of good food. This statement had a steadying effect, for medical officers at certain places had been rejecting everything with disastrous results, so far as the owner of the meat was concerned, and defeating the aim and object of public abattoirs. It is possible these medical officers were influenced by the decision of the Congress for the study of Tuberculosis in Man and Animals, held in Paris in 1888, which passed a resolution of total condemnation of the carcase no matter how slight the evidence of disease might be.

It is entirely owing to the labours of the Royal Commission, guided in these purely expert points by the opinion of



McFadyean, that the question has been placed on a common-sense basis. He adduced the veterinary returns of a rigid system of meat inspection in Saxony during the year 1895, which showed that 22,758 carcasses were during that time found to be tuberculous, but of which 92½ per cent. were passed as fit for food, 5½ per cent. were disposed of at a cheap rate after thorough cooking, and only 2 per cent. of the whole condemned as unfit for food.

The Commission, therefore, arrived at the conclusion that a stage of experience and knowledge had been attained as to the nature of tuberculosis, and the effect of tuberculous meat on the consumer, to enable a uniform standard to be prescribed for the guidance of meat inspectors. The broad basis of their recommendation was that the seizure of meat should be strictly confined to such parts as are dangerous to human health, while the non-affected portions of the carcass might be consumed.

To this end they submitted the following classification of tubercular lesions, with the needful action to be taken in each case. These recommendations are on much the same lines as the resolutions passed at the International Veterinary Congress held at Berne in 1896, and in close agreement with the official regulations in France and Germany.

‘ Pending the issue of such instructions, we are of opinion that the following principles should be observed in the inspection of tuberculous carcasses of cattle :

- |  |  |
|--|--|
| <p>(a) Where there is miliary tuberculosis of both lungs ... ..</p> <p>(b) When tuberculous lesions are present on the pleura and peritoneum ... ..</p> <p>(c) When tuberculous lesions are present in the muscular system, or in the lymphatic glands embedded in or between the muscles ... ..</p> <p>(d) When tuberculous lesions exist in any part of an emaciated carcass .. ..</p> | <p>} all the organs may be seized.</p> |
|--|--|

- |  |  |
|--|--|
| <p>(a) When the lesions are confined to the lungs and the thoracic lymphatic glands ... ..</p> <p>(b) When the lesions are confined to the liver ... ..</p> <p>(c) When the lesions are confined to the pharyngeal lymphatic glands ... ..</p> <p>(d) When the lesions are confined to any combination of the foregoing, but are collectively small in extent ... ..</p> | <p>} The carcase, if otherwise healthy, shall not be condemned, but every part of it containing tuberculous lesions shall be seized.</p> |
|--|--|

‘In view of the greater tendency to generalization of tuberculosis in the pig, we consider that the presence of tubercular deposit in any degree should involve seizure of the whole carcase and of the organs.

‘In respect of foreign dead meat, seizure should ensue in every case where the pleura has been “stripped.”’

In connection with tuberculosis of the pig, there is a feeling that the seizure of the whole carcase is unnecessary; this question is now under consideration.

*Parasitic Diseases.*—There are certain parasitic conditions of the body which affect its value as meat, or render it completely unfit for food.

We should unhesitatingly condemn any animal the flesh of which contains any parasite transmissible to man. Such parasites are :

*Cysticercus bovis*, producing in man *T. saginata*.

*Cysticercus cellulosæ*, producing in man *T. solium*.

*Trichinosis*, producing in man the same disease.

The cysts in *C. bovis* vary from a millet seed to a small pea, they are spherical or elliptical in shape, grayish in colour, and when enucleated a cavity is left behind in the muscle. The cyst contains the head of the future tapeworm. The parasite only lives about six months in the muscles of the ox; it then dies and becomes calcified. Flesh with calcified cysts may be harmless, but is excessively repugnant.

The muscles most commonly affected are those at the root and frenum of the tongue, the muscles of mastication,

pterygoids, heart muscle, and those of the shoulder and haunch.

*C. celluloseæ* affects the muscles of the pig, the cysts closely resembling those of *C. bovis*. The muscles chiefly affected are those of the tongue, heart, muscles of mastication, neck, chest, muscular part of the diaphragm, and sometimes the liver.

There are no statistics available to show what proportion of British pigs are affected with this disease, but both on the Continent of Europe and in the East it is frequently met with.

Measly beef and pork may contain a few or many cysts ; but no distinction should be made between them until an institute exists corresponding with the German Freibank (see p. 679) ; until that time arrives the whole carcase of even a slightly affected case should be destroyed.

*Trichinosis*.—This disease is mainly found in American pigs, and those of the Continent of Europe, especially in Germany. We have previously (p. 666) referred to the systematic examination which pork receives in Germany. It receives none in this country in spite of the amount of bacon we import from America, and it cannot be doubted that trichinosis finds its way in.

Ingestion of the flesh containing the parasites causes their liberation in the intestines, from here in the course of a few days they pass into the muscular tissues. Swine contract the disease from eating rats, mice, and the flesh of their own species infected with trichinæ.

The muscles most commonly affected are the pillars of the diaphragm, shoulder, loins, larynx, tongue, cheeks, and intercostals. In Germany the microscopical inspection is very thorough, no inspector is allowed to examine more than twenty pigs a day, and there is a stipulated time, varying in different districts from fifteen minutes to half an hour, during which the examination must last. Women do a great deal of the work, and in one place they combine it with midwifery. In some districts special rewards are paid for the discovery of trichinosis, which

suggest that the examinations are not always conscientiously performed.

Salting the flesh kills the parasite in course of time, but the discovery of trichinæ in either fresh or salted pork should insure seizure.

There are parasites harboured by the herbivora which though not communicable to man are so to other animals. The bladder worms mainly found in the peritoneal cavity of sheep, *Cysticercus tenuicollis*, produce *Tænia marginata* of the dog. The flesh is fit for food unless otherwise indicated on account of emaciation, but the affected portions should be destroyed. *Echinococcus veterinorum* may be found in all herbivora as cysts in the lungs, liver, and other organs; it produces *T. echinococcus* in the dog. The flesh is quite fit for food, though the affected organs should be destroyed. Sheep contract *Cœnurus cerebralis* from *T. cœnurus* of the dog. When the brain is affected the part should be destroyed to avoid further infection of the dog. Sometimes the cysts of the disease develop in the muscular tissue, and the condition is then known as measles in sheep.

In fluke disease of either sheep or cattle the flesh of the latter is as a rule fit for food; mutton may also be passed so long as it is not pale and watery. In all cases the affected organs should be destroyed.

Calves suffer from *Ascaris vituli* which sometimes gives to the flesh a peculiar sour smell, nauseating to some people though not harmful. The intestines should be destroyed. This rule should also follow in all cases where the wall of the intestine is affected by parasites, which renders them unfit for sausage skin purposes.

#### *Statistics of Condemnation.*

In the Metropolitan Cattle Market the veterinary officer reported for the year 1901 that 947 whole carcasses, and 275 partial seizures for disease were effected during the year, out of a total of 167,937 animals slaughtered; the

pathological conditions of 1202 carcasses are thus tabulated, and are interesting as showing the relative frequency with which disease is met with :

Tuberculosis	...	...	730	Cancer	...	...	...	...	3
Dropsy	...	...	339	Jaundice	...	...	...	...	3
Emaciation	...	...	39	Pyæmia	...	...	...	...	3
Smothered	...	...	18	Unmarketable	...	...	...	...	2
Injured	...	...	17	Parturient apoplexy	...	...	...	...	1
Inflammation	...	...	16	Died in transit	...	...	...	...	1
Hydatids	...	...	8	Erysipelas	...	...	...	...	1
Pleurisy	...	...	7	Urticaria	...	...	...	...	1
Peritonitis	...	...	6	Pneumonia	...	...	...	...	1
Actinomycosis	...	...	5	Swine fever	...	...	...	...	1

Of the 1,222 carcasses condemned, no less than 1,008 were those of cows, and this is the history in all abattoirs. Tuberculosis is the common cause of meat being seized and the animal most frequently affected with tuberculosis is the cow. In Glasgow in two years 1,286 carcasses were condemned for tuberculosis, of which 1,260 were those of cows. At Birkenhead in five years 71 carcasses were condemned, of which 64 were cows.

The figures published by Trotter\* of tuberculosis among the animals slaughtered in Glasgow are probably the most complete in this country. During 1901-1903, of 3,272 carcasses of Home Cattle seized for total destruction for tuberculosis, no less than 3,058 were cows, and of 2,299 partial destructions, 1,984 were cows.

This observer shows that of 47,362 Home Cattle slaughtered at Glasgow 15·8 per cent. were affected with tuberculosis, while of 39,638 Foreign Cattle only 1·11 per cent. had tuberculosis !

We have clearly stated that the Medical Officer is the only person who is justified in saying what is fit for human consumption, and with his opinion the veterinary inspector of meat should on no account interfere. So long as the veterinary inspection of the animal alive and dead has been

\* Annual Report of Mr. A. M. Trotter, Veterinary Surgeon to the Corporation of the City of Glasgow for 1903.

thoroughly and conscientiously performed, the matter so far as we are concerned is at an end. Nor need we resent the subsequent rejection of such meat as has been passed free from disease, as in the course of a few days it might obviously be unfit for consumption from putrefaction.

### *Meat Poisoning.*

Cases of meat poisoning are fairly common, and it appears to us these are the only conditions likely to arise which may reflect on the inspector of meat. Experience goes to show that cases of poisoning are infinitely more common, where the meat has been derived from an animal which has been destroyed in order to prevent it dying from disease.

Herein lies one of the advantages of an inspection of the animal during life. That there are many conditions, such as fractures and incurable injuries, where the flesh immediately after the accident is perfectly healthy is undoubted, but if the animal is kept alive until fever sets in the flesh takes on the characteristic 'fevered' condition, and should be rejected without hesitation.

The responsibility of the veterinary profession in the inspection of meat, suspected to have been obtained from an animal which has been killed on the point of death or that has actually died, is indeed very great. By an inspection of the viscera the examiner may satisfy himself of the stage of disease at which the animal was destroyed; by the evidence afforded by the muscular tissue he may suspect that the conversion of the animal into meat was only resolved upon at the last moment. Under the latter condition there should be no hesitation in rejecting the whole carcase, no matter what the affection was; in the former case the thorough bleeding which the muscular tissue may exhibit, and the stage of the pathological lesion as revealed by inspection must settle the point, the slightest doubt being given on the side of rejection rather than acceptance.

The chief object of this is to avoid the risk of meat poisoning, which is due to the formation in the flesh of one or more toxins unaffected by cooking, and capable, under certain circumstances, especially in the case of pork, of giving rise to the most alarming symptoms amongst consumers. An outbreak of pneumonia at Middlesbrough in 1888 which caused 490 deaths was attributed to American bacon, and many smaller outbreaks of disease, due generally to pork, have from time to time been reported.

That the flesh of animals on the point of death, or even dead of disease, has been eaten with impunity is quite undoubted, but the idea is repulsive and is a state of affairs which cannot for one moment be countenanced. If in practice a client prefers to take the chance of his animal recovering, rather than converting it into beef or mutton while there is still time, no change of opinion at the eleventh hour should receive any support or countenance from the professional adviser, who should direct the knacker and not the butcher to be called in.

#### *The Utilization and Destruction of Condemned Meat.*

In certain parts of Germany a system exists of utilizing the meat of animals found after slaughter to be affected with disease, the actual diseased parts being rejected.

This opens up a profoundly economic question; the attitude adopted by the State is that the public have a right to elect whether they shall eat meat known to be of inferior quality, owing to it having been derived from diseased animals, while the State protects them from any possible harm in the matter by cooking the meat before sale.

No meat unfit for human use and dangerous to health is included in this method.

'Freibank' meat, as it is called, has been known in Germany for some centuries, but it is only in recent years, since obligatory meat inspection has been introduced, that the question has assumed important proportions.

By the sale of Freibank meat, about one-third of the original value is saved instead of the whole being lost. There is no sale effected under false pretences, the public know they are buying the meat of diseased animals, but removed from healthy parts and of good quality.

Freibank meat is subjected to cooking in a special apparatus; the boiling, disinfection, and sterilization being carried out by steam at about 12 lbs. pressure, and a temperature of 212° F. to 248° F. By this process the meat is rendered completely germ free, at the same time it

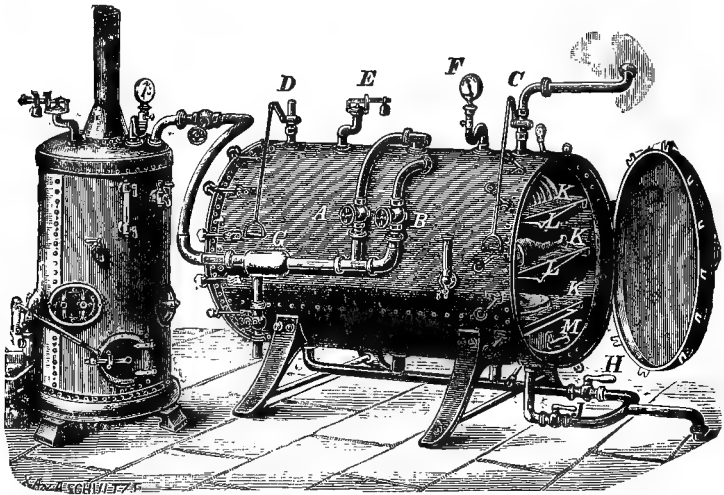

Fig. 194.—The Becker-Ullman Cooking or Destroying Apparatus.\*

suffers no loss in its nourishing properties, retains its juices and extractives, and is not as insipid as if boiled.†

In the apparatus in Fig. 194 the meat, cut in slices 4 inches or 5 inches thick, and 7 lbs. to 14 lbs. in weight, is placed on iron shelves, which are run into a jacketed cylinder. The steam is let in above, either into the jacket or direct

\* 'Public Abattoirs and Cattle Markets': Dr. Schwarz. Translated by Harrap and Douglas.

† For information on this subject I am indebted to 'Public Abattoirs and Cattle Markets,' from the German of Dr. O. Schwarz, by Messrs. Harrap and Douglas.



into the cylinder. The temperature to which the meat is raised is ascertained by a pyrometer inserted into the middle of the thickest piece, which works an electric bell outside the apparatus when the desired temperature is reached.

This apparatus can also be used as a destructor by allowing the steam to only enter the jacket, by which means the cylinder is formed into a drying chamber, and the destruction of meat unfit for consumption can be effected.

In the reference given above, the whole matter is very fully dealt with, and various forms of destructor figured.

In Germany the work of destruction of diseased meat unfit for human consumption, is so arranged that the useful material from it, fat, glue, bone-meal, meat-meal, etc., is extracted so as to assist in covering the cost of destruction. This is a more economical system than putting the carcase into a furnace and only recovering the ashes.

The Podewill destructor (Fig. 195) consists of a rotating cylinder having a steam jacket. After the apparatus is filled at a manhole, the cover is replaced, and steam admitted at 320° F., with a pressure of 60 lbs. to 90 lbs. In the course of three or four hours sterilization is completed, and the fat, having separated is drawn off. The next step is to dry and crush the contents of the cylinder, and for this purpose steam is allowed to enter the jacket only; the cylinder is rotated, and a roller inside crushes and grinds the material. After seven or ten hours of this process the material, flesh, horns, bones, etc., are reduced to powder, the cover is removed from the manhole, and sacks are filled from below. There is no odour from the apparatus as everything is done under air-tight conditions.

The destruction of unsound meat at Glasgow, was at one time effected by placing it in a solution of picric acid and iron sulphate for several hours, but it was found that this did not penetrate more than the one-sixteenth of an inch, and that the removal of the surface was sufficient to obliterate all traces of the dipping.

Crude carbolic acid, creosote, cresylic acid, and chloride of lime, were tried by sprinkling the meat with the agent, but they did not penetrate into the interior, and were

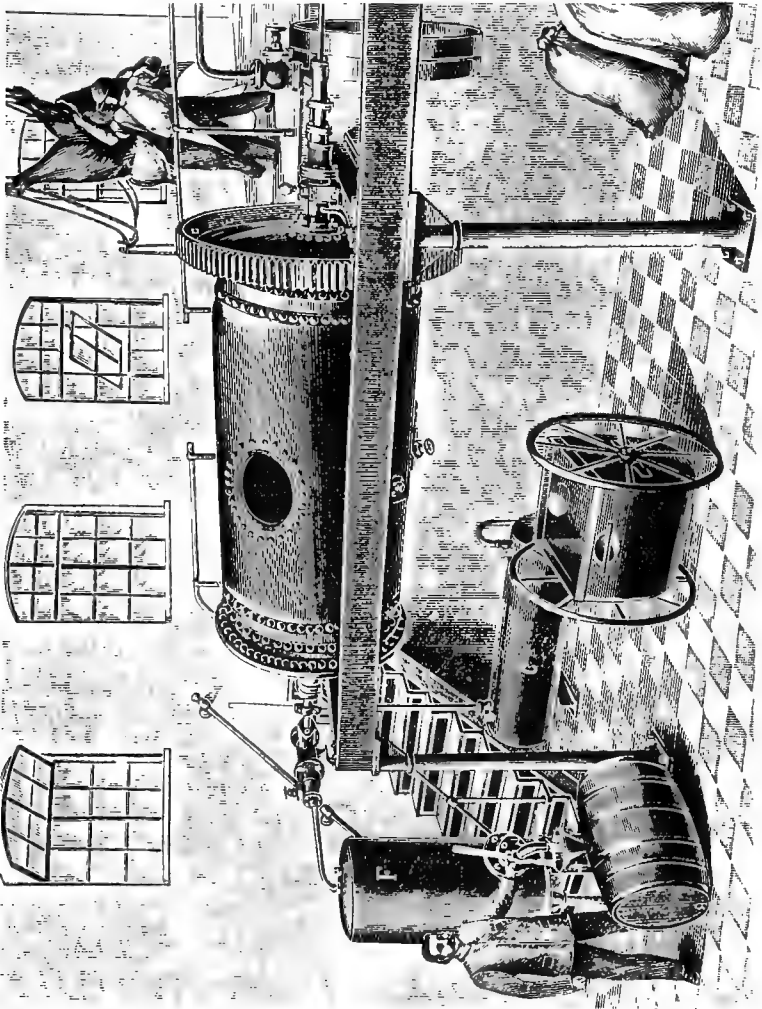

Fig. 195.—The Podewill Destructor for Diseased Carcasses (Schwarz).

found to be useless for the purpose of rendering meat sufficiently offensive to prevent its use as food.

The Corporation of Glasgow found the only way to deal

with unsound meat, was to arrange with various firms to convey it to a special place for boiling down, by a route mutually agreed upon, and to be conveyed in locked carts sealed by an inspector at the slaughter-house.

If these elaborate precautions are necessary in order to prevent people eating garbage, the success in this country of an institution on the lines of the Freibank is undoubted.

#### *Sale of Horse Flesh.*

The sale of horse flesh as human food is controlled by the Sale of Horse Flesh, etc., Regulations Act, 1889, and in this Act the term horse flesh includes that of asses and mules. Horse flesh can only be sold in a place over which a conspicuous notice is placed announcing the fact. A heavy penalty attaches to the sale of horse flesh to any purchaser asking for other meat.

Any officer of the Sanitary Authority, besides the Medical Officer and Sanitary Inspector, may have the power of inspecting places kept for the sale of this food.

#### DAIRY INSPECTION.

When in 1879 the first Orders were published which brought dairies under some form of sanitary control, the State very rightly vested the powers of the inspection of cows, sanitary arrangements of cow-sheds,\* etc., in the hands of the veterinary surgeon, but later on it was transferred from the veterinary to the medical profession. This transfer, hardly by a coincidence, occurred shortly after the medical discovery of some ailment of cows, which, owing to the ignorance of the veterinary profession, had been hitherto unrecognised, and the milk of which was capable of producing scarlet fever in man!

We have stated that such an ailment of the cow never existed, and after the experience mentioned on p. 633,

\* For information regarding cow-sheds, ventilation, drainage, cubic and superficial space, see p. 320.

the professional care of dairy stock, and the hygiene of the cow-house, ought to have found its way back into the charge of those who by their training and experience are legitimately qualified for the work. But from 1886 to 1899 veterinary aid was ignored by the Local Government Board. In the latter year the Royal Commission on Tuberculosis forced their hands, by recommending that tuberculosis of the udder should be included as a 'disease' under the Diseases of Animals Act on the certificate of a veterinary surgeon. As a result an Order had to be issued by the Local Government Board, which once more brought back to the dairy the only person with any knowledge of the subject, though at present with but modified powers.

It is interesting to note that when the Local Government Board drew the attention of the Councils of Rural Districts to this new departure, they made the following remarks :

'The Board think that it will be competent for the Council to employ and pay a veterinary surgeon with the view of obtaining a certificate under the Article as amended, or to appoint him as an officer for this purpose, if they think fit to do so.'

The object of this instruction is not very clear. It is evident a veterinary certificate could not be obtained without employing a veterinary surgeon, and it is quite certain that if employed he has to be paid. This suggested appointment as an officer *for this purpose* is not without significance.

Article 13a of the Dairies, Cowsheds, and Milkshops Order of 1885 provides 'For the inspection of cattle in dairies.' This as matters at present stand, and as the Local Government Board intended it should be when powers were transferred to them in 1886, falls to the Medical Officer of Health ; by the previous Order of 1879 and 1885 it was the duty of the veterinary surgeon. In the instructions to Rural Councils above quoted, it is clear that the Board by accurately defining the veterinary surgeon's sphere of usefulness to the determination of tuberculosis of the udder, are bent on retaining in their hands the veterinary inspection of dairy stock and the

hygiene of the cow-shed, for both of which duties they are unfitted by training or experience.

We wish to be quite clear on this matter ; the cleanliness of milk-stores, milk-shops, milk-vessels, and the precautions to be taken against the contamination of milk for sale, are obviously the duties of the Medical Officer of Health, and we have no desire to usurp his functions. His duties lie in the dairy, ours in the cow-house ; we meet on common ground for the protection of the public health. It is to the veterinary profession that the inspection of dairy stock should be consigned, and for it to prescribe and regulate questions of lighting, ventilation, cleansing, drainage, and water-supply of cow-sheds, and beyond that we have no wish to go.

Greater enlightenment than that exhibited by the Local Government Board has, however, been shown by various urban authorities, who, recognising the absurdity of employing an unskilled man to do the work of one whose special training it is, have appointed veterinary surgeons as dairy inspectors, and thereby not confined their usefulness to the detection of tuberculous udders, but have extended it to the entire hygienic surroundings of the cow. Rural authorities, on the other hand, whether from poverty, vested interests, or indifference, have not yet awakened to the importance of this change. There may be ulterior motives behind it ; the bulk of our milk-supply is rural rather than urban, towns and cities are dependent on the country, and the milk interests of the latter might be somewhat severely shaken by having to get rid of their tuberculous stock, and cleanliness insisted upon. As a profession we are indebted to the municipalities of Birmingham, Manchester, Leeds, Edinburgh, Glasgow, and other cities, for enlightened veterinary arrangements and control.

But this control only exists within their own boundaries, a dairyman outside the municipal boundary, excepting in certain cities which possess special powers, is not under control, he can sell tuberculous milk, and continue the old filthy system of milk-supply unchecked and uncontrolled.

The same condition applies, as we saw in dealing with Meat Inspection. The private slaughter-house outside the boundary of a city can do as it likes, while a few yards, perhaps, further away, the most rigid system of meat inspection is enforced.

The fact is that the old error of permissive legislation here exists, a system we have many times alluded to in these pages; it is a blot on our administration and our national common-sense, and the earlier it is removed the better.

Certain urban authorities have recognised the absurdity of rural authorities being permitted to accept or reject regulations framed for the public good, and have endeavoured by obtaining extra Parliamentary powers to neutralize the apathy and indifference of the rural authorities surrounding their cities. But even with these the value of the work is greatly curtailed, owing to the restrictions imposed; an example of these will suffice.

If the Municipal Authorities of certain cities suspect the milk-supply of a dairy in a Rural District, they have power to examine the suspected cows, but before doing so they must have some evidence laid before them on which to act. Assuming it is a case of supposed tuberculosis, the evidence must be such as may be supplied by a microscopical examination of the milk. As all milk from a dairy is mixed, the chance of detecting a culprit by the microscope is at best remote. However, assuming sufficient facts have been accumulated to warrant an inspection of the suspected dairy, an order from a magistrate is then required, and after due notice has been given to the owner of the suspected stock a veterinary inspection is made, with the possible result that during this process of circumlocution the suspected cow or cows have disappeared.

In Scotland the matter is much better arranged; there the Medical Officer of Health reports direct to the local authority in which the suspected dairy is situated, and they are compelled to send a medical and veterinary officer to inspect and report.

Malcolm\* has written fully on the question of the inspection of dairy stock, of which subject he is an acknowledged specialist. He states that in no other way, under existing permissive legislation, is it possible to meet a case like the above, than by municipal authorities having the right to inspect the dairy stock of any milkman who sells milk within their jurisdiction without waiting for the order of a justice. Such legislation if obtained would be very far reaching, and exercise a wholesome control which at present does not exist in rural districts, entirely owing to conservative instincts, and the fear entertained of private interests suffering.

Malcolm shows how as the result of his inspection of dairy stock in Birmingham the general health of the cows improved, due, as he points out, to the fact that dairymen exercised more care in the selection of stock for purchase, when they realized that systematic inspection brought to light defects in their herd.

He dwells on the importance of the veterinary inspector possessing the confidence and respect of the cow-keeper, and this can only be secured by an impartial and considerate discharge of his duties, by his knowledge of the subject, and his quick detection of abnormal conditions. He must know more of the subject than the cow-man, and this holds good through the whole range of veterinary work.

It is necessary in the inspection of dairy stock that something more than looking at the udder should be carried out. It is true that any marked departure in size or shape can be seen by inspection, but the most important condition which requires early diagnosis, viz., tuberculosis and parenchymatous mastitis, can only be determined by a manual examination of the gland and an inspection of its secretion.

The following conditions of the udder are described, and though it is slightly departing from the general plan

\* 'Veterinary Dairy Inspection,' by Mr. J. Malcolm, F.R.C.V.S., *Journal of Comparative Pathology*, vol. xiv., part i., 1901.

of this work to speak of symptoms, it is permissible, owing to the growing importance of the subject from a public health point of view, to note the differential diagnosis of conditions which to the untrained eye are very similar in appearance, though known to be quite distinct conditions.

In the inspection of dairy stock the udder must be examined for the following diseases :

*Tubercular mastitis,*  
*Catarrhal mastitis,*  
*Acute parenchymatous mastitis,*  
*Interstitial mastitis,*  
*Traumatic mastitis,*  
*Contagious mastitis,*  
*Cow-pox,*  
*Spurious cow-pox,*  
*Chaps and cracks of the teat.*

*Tuberculosis of the Udder.*—This condition involves one or more quarters, generally a posterior one.

The earliest indication is a slow indolent swelling in the depth of the gland, gradually extending and invading the whole quarter or even the whole gland. There is but little pain, no heat or sign of acute disturbance, the change, in other words, is essentially chronic, and may take six or eight weeks to accomplish, or much longer. On manipulating such an udder the swelling is found to be large and fleshy, and the inguinal lymphatics may also be found enlarged.

In the early stages the milk undergoes little or no alteration, but later on it becomes scanty, and transformed into a more or or less watery liquid. Malcolm describes the early diagnosis of tuberculosis, and the effect of its notification on the owner as follows :

‘When first examining such a case the milkman generally confidently asserts there is nothing the matter with the cow’s udder, nor ever has been, and further assures you the milk is all right, in proof of which he at once milks the suspected quarter and asks you to inspect



the milk. He little realizes that in a case of indolent, gradually extending induration of the udder, the fact that the milk retains its normal appearance for a time is a very grave symptom, and, to say the least, very highly suspicious of the existence of tuberculosis of the udder.'

The essential feature in the swelling of tuberculosis of the udder is that, unlike other forms of mastitis, the gland does not pass into the condition of atrophy, which so commonly sets in after other disturbances, that of actinomycosis being, of course, an exception. The permanent increase in size and density of the organ are symptoms of supreme importance.

This increase in size may, as we have previously noted, take a few weeks, but before the gland shows any actual hardening the milk may contain bacilli. It is not easy to see, as matters at present stand, how the existence of disease can be determined earlier, but it points to the necessity for systematic inspection of the udders of all dairy stock, if possible once a month, and at longest once in two months.

A good deal has been written on the proportion of cattle affected with tuberculosis, especially since the introduction of tuberculin. McFadyean\* regards 30 per cent. of the cattle in Great Britain as tuberculous, but though tuberculous udders have been placed as high as 10 per cent., this authority believes that 2 per cent. would be nearer the truth. In this way he considers that as the average number of cows in a dairy is under fifty, the majority of dairies and farms supply milk free from tubercle bacilli.

Both McFadyean and Nocard lay great stress on the amount of dilution to which tuberculous milk may be exposed. When the tuberculous milk is largely diluted by mixing, as it would be in a big establishment, the danger of infection is greatly reduced, whereas the milk from a small establishment, and from single cows, may be most highly infective.

\* 'Tubercle Bacilli in Cow's Milk a possible Source of Tuberculous Disease in Man': Address to the British Congress on Tuberculosis, London, July, 1901.

To infect by the digestive tract the fluid must be rich in bacilli; diluted tuberculous milk, which is unable to infect by ingestion, will readily produce the disease by inoculation.

The medical profession may here learn a lesson, and unless absolutely assured of the freedom of the cow from tuberculosis, it would be far better and safer not to insist on a special one being kept for invalids and children.

The case we have presented stands thus: 28 per cent. of our dairy stock suffer from tuberculosis not presenting clinical appearances; 2 per cent. suffer from clinical tuberculosis, viz., of the udder. What repressive measures exist for the control of this state of affairs?

So long as the udder remains free from disease nothing can be done. The law, which is most exacting with regard to the milk from an anthrax case, takes no notice of tuberculosis, though in the former it is doubtful if a single bacillus can pass the filter afforded by the mammary gland, while in the other actual tubercular disease of the gland may set in any day. Even when the disease is known to affect the udder, all the law can do is to stop the sale of such milk; it cannot compel the owner to destroy the animal, nor insist on the affected cow being removed from amongst the healthy, where it is a source of extreme danger. Certain municipalities have, however, obtained powers, making it a punishable offence to keep a cow affected with a tuberculous udder among other cows in milk.

On this point we cannot do better than quote that portion of McFadyean's address dealing with this matter.

'The present state of the law, or rather the almost entire absence of any law dealing with tuberculous udder disease in cows, is a scandal and a reproach to civilization. It scarcely sounds credible, but it is a fact that the owner of a cow in the most advanced state of tuberculosis, and exhibiting the most manifest signs of udder disease, may sell that cow's milk for human food so long as the sale has not been specially interdicted on the certificate of a veterinary surgeon, and no penalty attaches to the crime of deliberately or carelessly placing on the market a food material charged with the germs of a dangerous disease.'

*Catarrhal Mastitis.*—This disease is, as a rule, confined to one quarter of the mammary gland, and consists of an inflammation of the milk sinus and ducts. On manipulation there is a hardening at the base of the teat and around the sinus, but not accompanied by any degree of pain or acute symptoms, while the affected quarter presents no marked enlargement. The disease runs a slow course, and it is some time before the milk regains its normal condition. Even for a time after recovery some thickening and induration remains in the lower portion of the gland.

The milk drawn from the affected side at first shows no apparent change, but if allowed to stand until the cream separates it looks watery, almost translucent, while with the cream appears to be a mucoid material.

Microscopical examination of the milk reveals the presence of leucocytes, epithelial cells, and a few streptococci.

Malcolm, whose description we have literally followed, tells us that though this condition of the gland may be due to bacterial infection, dairymen have no doubt that it is less frequent with careful competent milkers than with incompetent.

*Acute Parenchymatous Mastitis* is an acute inflammation attacking two or more quarters or the whole gland. Well-marked constitutional disturbance exists, with heat, swelling, and pain of the udder. Suppuration soon follows the occurrence of the disease, and a complete loss of the secreting quarter, with subsequent atrophy, is a common sequel.

In the early stages the milk is reddish-brown in colour, and presents the appearance of a dirty flaky serous fluid. On standing it separates into three layers, the precipitate being casein, a reddish-brown whey existing as a middle layer, and a mucoid greasy-like material on the top.

Later on the milk becomes thicker, more or less purulent in character, and eventually is little more than a thick creamy pus.

It frequently happens that more than one case of the disease occurs at the same time, and this and other con-

siderations suggest bacterial infection as the prime cause, the organism gaining access to the gland through the teat-duct.

*Subcutaneous or Interstitial Mastitis* is an acute inflammation of the subcutaneous and interstitial tissues usually affecting the half or whole of the udder, and characterized by heat, pain, and marked swelling. There is slight constitutional disturbance, but no alteration in the character of the milk, though the quantity may be diminished.

Such cases, often attributed to cold, are probably the result of skin infection through some injury.

*Traumatic Mastitis* is the result of external violence, especially in cows with large udders. The degree and severity of the attack depend upon the extent of the injury; the formation of small subcutaneous abscesses is by no means uncommon, and where the gland structure is not involved no alteration in the character of the milk occurs.

*Specific Contagious Mastitis* is a well-recognised condition recorded by Malcolm and others. Besides slight constitutional disturbances there is a rash on the base of the teats, and tumefaction and induration of the gland structure surrounding the milk sinuses, with pain on pressure.

There is a marked reduction in the quantity of milk, which in appearance is of a dirty yellow colour, containing curdled stringy clots.

In an outbreak recorded by Radway\* the milk after standing separated into a thin layer of cream, a flocculent deposit, and an intervening bluish layer of fluid; the fluid also had an odour resembling decaying vegetable refuse. In this particular outbreak the milk gave the first indication of something being wrong; it was not until later that hardening of the affected quarter and base of the teats occurred, and no rash at any time appeared.

From observations made by Riddoch† the incubative

\* 'Contagious Mastitis in Cows': Mr. C. Radway, M.R.C.V.S., *Journal of Comparative Pathology*, vol. xv., part iv., 1902.

† 'Contagious Mastitis in Dairy Cows': Mr. John Riddoch, M.R.C.V.S., *Journal of Comparative Pathology*, vol. xv., part iv., 1902.

period of the disease would appear to be from eight to ten days.

The hygienic measures to be adopted in infectious udder trouble (and probably most udder troubles are infectious) are very clear. All affected animals with their attendants must be at once isolated; bearing in mind the fact that the spread of disease is through the hands of the milkers, the necessity for their isolation is as urgent as that of the affected cows. The place occupied by the diseased animals must be thoroughly disinfected, half measures are of no use, for it is known that under certain circumstances the disease may be most persistent.

In the outbreak recorded by Radway the most careful disinfection failed to combat the disease; fresh cows became infected, as he suggests through the milkers handling infected milk-churns: the owner had eventually to get rid of the whole of his stock and evacuate the place for six months, during which time it was thoroughly disinfected and thrown open to air and sunlight, which proved effective.

The great danger is the milker, and the necessity for his thorough disinfection, especially the hands, is evident. Hands are by no means easy to disinfect: scrubbing with soft soap and hot water, followed by methylated spirit, and finally bichloride 1-1000, is effective under thorough supervision; supervision which is, in fact, most difficult to insure with a class not remarkable for habits of ordinary cleanliness, and to whom surgical cleanliness appears superfluous and unnecessary.

It is fair to assume where the disease continues in spite of every apparent care, that a loophole exists somewhere which requires detection.

The washing out of churns and other vessels with boiling water may not prove sufficient; immersion and boiling would no doubt suffice, but for large vessels this may be difficult to carry out. In such cases the only method is to fill the churn with water, and light a fire below and boil for an hour. The whole of the outside may for safety be

disinfected with a plumber's lamp or lighted wisps of straw.

*Cow-pox* appears as a vesicular eruption on the udder and teats, which about the eighth day passes into a pustular stage. The number of eruptions on each teat and quarter is generally two or three, but may in severe cases be four or five. The eruption is circular or oblong in shape, with either a flattened or umbilicated centre, and a slightly raised, well-defined areola. The rupture of the vesicle is followed by a brown crust under which healing occurs, and when this falls off a depression remains surrounded by a brownish tint of skin.

The eruption is accompanied by fever and a slight diminution of milk-supply. Irritation from the hands of the milker delays the process of healing. Infection both of the milker and the remaining cows will almost certainly occur; either may be a source of infection to the other.

The disease it will be observed is a mild affection in the cow, and its chief interest lies in the fact that the lymph of the vesicle gives protection against human small-pox.

It is almost certain that it was this affection which was blamed by the medical profession for producing scarlet fever in man, referred to on p. 633. As no veterinary opinion was called in until too late for diagnostic purposes, the nature of the Hendon eruption will always remain one of conjecture.

Malcolm in describing cow-pox, refers to a spurious form of the disease or varicella, the eruption of which is quite distinct, the vesicles being small, superficial, acuminate, and not surrounded by a tumefied areola. Further there may be successive crops of vesicles, though usually the disease only lasts a week or ten days.

Varicella, like true vaccinia, is capable of transmission from cow to cow by the hands of the milker.

The question of the use of milk for human purposes derived from any form of diseased udder is one entirely for the consideration of the medical profession. Where the actual gland substance is involved, or the milk sinus and

teat canal, there can be no doubt that its use should be prohibited; but we would be departing from the standard laid down if we ventured to interfere in any way with this question. The Medical Officer of Health is acting quite within his province if he pours the whole milk-supply down the drain when he thinks it desirable, though under certain circumstances we may have our own ideas as to the necessity for this procedure. But as we distinctly say he has nothing to do with the cow, so with equal distinctness we have nothing to do with the milk, otherwise we would create a position as intolerable as that which arises from his interference with veterinary work. We refer entirely to the consumption of milk; the departure of milk from the normal is an important matter to us from a diagnostic standpoint, and our knowledge of this should be as complete as that of the medical officer, but with a different object in view.

We have been compelled, owing to its importance, to dwell on the question of the respective duties of the medical and veterinary officer. The scheme proposed is the only workable one for the future, and the only one which can unite conflicting interests and work for the public good, which after all is the sole objective.

Before concluding this section dealing with the inspection of dairy stock, it is desirable to refer to the question of existing and proposed legislation. The former is very elementary, viz., only milk from a tuberculous udder can be interdicted on the certificate of a veterinary surgeon. This presupposes also that the local authority in whose district the incriminated cow exists, have adopted the Orders bearing on cow-sheds and milk-shops, which as matters at present stand they may either accept or reject. The whole thing is utterly incomprehensible, and shows how desirable it is for an old conservative nation to be regenerated.

It should be compulsory for every cow proprietor to notify to the local veterinary authorities the existence of any form of udder disease. It is quite possible that even with this tuberculosis might escape detection for some time,

but it is a step in the right direction, and throws the onus on the owner or person in charge, as is the case with all scheduled diseases under the Diseases of Animals Act.

Every case of tuberculosis of the udder should be destroyed, of this there can be no possible doubt, and the most thorough disinfection of the building carried out.

It should be the duty of the veterinary officer to inform the medical officer of the existence of udder disease in any dairy; he should also notify when the cows are restored to health, and leave it entirely to the medical officer to settle the question of when the milk is fit to issue; that is a matter entirely outside our province.

The Royal Commission on Tuberculosis recommended :

1. Compulsory notification of every disease of the udder, whether in private dairies or those of which the milk is offered for sale.
2. Systematic inspection of the cows in dairies and cowsheds.
3. Power for a medical officer to suspend the supply of milk from any suspected cow for a period not exceeding 48 hours, pending veterinary inspection.
4. Power to prohibit the sale of milk from any cow, certified by a veterinary surgeon to be suffering from such disease of the udder as in his opinion renders the animal unfit for the supply of milk, or exhibiting clinical symptoms of tuberculosis.
5. The provision of a penalty for supplying milk for sale from any cow having obvious udder disease, without the possession, by the owner, of a certificate to the effect that such disease is not tubercular.

It is significant that the recommendations of the Commission are mainly based on Sections 24-27 of the Glasgow Police (Amendment) Act, which further gives the local authorities power to slaughter such cows subject to compensation.

The only action taken by the State after the Commission



reported, was to include tuberculosis of the udder as a 'disease' under the Diseases of Animals Act, and to prohibit the use of the milk of a cow so affected. It neither compelled destruction of the animal, nor insisted on its removal from the other stock, though some local authorities, like Manchester, possess these powers.

#### LEGISLATION.

##### THE DAIRIES, COWSHEDS AND MILKSHOPS ORDER OF 1885.

###### *Short Title.*

1. This Order may be cited as the Dairies, Cowsheds and Milkshops Order of 1885.

###### *Extent.*

2. This Order extends to England and Wales and Scotland only.

###### *Commencement.*

3. This Order shall commence and take effect from and immediately after the thirtieth day of June, one thousand eight hundred and eighty-five.

###### *Interpretation.*

4. In this Order—

The Act of 1878 means the Contagious Diseases (Animals) Act, 1878. Other terms have the same meaning as in the Act of 1878.

###### *Revocation of Former Order.*

5. The Dairies, Cowsheds and Milkshops Order of July, 1879, is hereby revoked.

###### *Registration of Dairymen and others.*

6. (1) It shall not be lawful for any person to carry on in the District of any Local Authority the trade of cowkeeper, dairyman, or purveyor of milk, unless he is registered as such therein in accordance with this Article.

(2) Every Local Authority shall keep a Register of persons from time to time carrying on in their District the trade of cowkeepers, dairymen, or purveyors of milk, and shall from time to time revise and correct the Register.

(3) The Local Authority shall register every such person, but the fact of such registration shall not be deemed to authorize such person to occupy as a dairy or cowshed any particular building, or in any way preclude any proceedings being taken against such person for non-compliance with or infringement of any of the provisions of this Order or any Regulation made thereunder.

(4) The Local Authority shall from time to time give public notice by advertisement in a newspaper circulating in their District, and, if they think fit, by placards, hand-bills, or otherwise, of registration being required, and of the mode of registration.

(5) A person who carries on the trade of cowkeeper or dairyman for the purpose only of making and selling butter or cheese or both, and who does not carry on the trade of purveyor of milk, shall not, for the purposes of registration, be deemed to be a person carrying on the trade of cowkeeper or dairyman, and need not be registered.

(6) A person who sells milk of his own cows in small quantities to his workmen or neighbours, for their accommodation, shall not, for the purposes of registration, be deemed, by reason only of such selling, to be a person carrying on the trade of cowkeeper, dairyman, or purveyor of milk, and need not, by reason thereof, be registered.

*Construction and Water-supply of New Dairies and Cowsheds.*

7. (1) It shall not be lawful for any person following the trade of cowkeeper or dairyman to begin to occupy as a dairy or cowshed any building not so occupied at the commencement of this Order, unless and until he first makes provision, to the reasonable satisfaction of the Local Authority, for the lighting, and the ventilation including air-space, and the cleansing, drainage, and water-supply, of the same, while occupied as a dairy or cowshed.

(2) It shall not be lawful for any such person to begin so to occupy any such building without first giving one month's notice in writing to the Local Authority of his intention so to do.

*Sanitary State of all Dairies and Cowsheds.*

8. It shall not be lawful for any person following the trade of cowkeeper or dairyman to occupy as a dairy or cowshed any building, whether so occupied at the commencement of this Order or not, if and as long as the lighting, and the ventilation including air-space, and the cleansing, drainage, and water-supply thereof, are not such as are necessary or proper—

- (a) For the health and good condition of the cattle therein ; and
- (b) For the cleanliness of milk-vessels used therein for containing milk for sale ; and
- (c) For the protection of the milk therein against infection or contamination.

*Contamination of Milk.*

9. It shall not be lawful for any person following the trade of cowkeeper or dairyman or purveyor of milk, or being the occupier of a milk-store or milk-shop—

- (a) To allow any person suffering from a dangerous infectious disorder, or having recently been in contact with a person so suffering, to milk cows or to handle vessels used for containing milk for sale or in any way to take part or assist in the conduct of the trade or business of the cowkeeper or dairyman, purveyor of milk, or occupier of a milk-store or milk-shop, so far as regards the production, distribution, or storage of milk; or
- (b) If himself so suffering or having recently been in contact as aforesaid, to milk cows, or handle vessels used for containing milk for sale, or in any way to take part in the conduct of his trade or business, as far as regards the production, distribution, or storage of milk—

until in each case all danger therefrom of the communication of infection to the milk or of its contamination has ceased.

10. It shall not be lawful for any person following the trade of cow-keeper or dairyman or purveyor of milk, or being the occupier of a milk-store or milk-shop, after the receipt of notice of not less than one month from the Local Authority calling attention to the provisions of this Article, to permit any water-closet, earth-closet, privy, cesspool, or urinal to be within, communicate directly with, or ventilate into any dairy or any room used as a milk-store or milk-shop.

11. It shall not be lawful for any person following the trade of cow-keeper or dairyman or purveyor of milk, or being the occupier of a milk-store or milk-shop to use a milk-store or milk-shop in his occupation, or permit the same to be used as a sleeping apartment, or for any purpose incompatible with the proper preservation of the cleanliness of the milk-store or milk-shop, and of the milk-vessels and milk therein, or in any manner likely to cause contamination of the milk therein.

12. It shall not be lawful for any person following the trade of cow-keeper or dairyman or purveyor of milk to keep any swine in any cowshed or other building used by him for keeping cows, or in any milk-store or other place used by him for keeping milk for sale.

*Regulations of Local Authority.*

13. A Local Authority may from time to time make Regulations for the following purposes, or any of them :

- (a) For the inspection of cattle in dairies.
- (b) For prescribing and regulating the lighting, ventilation, cleansing, drainage, and water-supply of dairies and cowsheds in the occupation of persons following the trade of cowkeepers or dairymen.

- (c) For securing the cleanliness of milk-stores, milk-shops, and of milk-vessels used for containing milk for sale by such persons.
- (d) For prescribing precautions to be taken by purveyors of milk and persons selling milk by retail against infection or contamination.

*Provisions as to Regulations of Local Authority.*

14. The following provisions shall apply to regulations made by a Local Authority under this Order :

- (1) Every Regulation shall be published by advertisement in a newspaper circulating in the District of the Local Authority.
- (2) The Local Authority shall send to the Privy Council\* a copy of every Regulation made by them not less than one month before the date named in such Regulation for the same to come into force.
- (3) If at any time the Privy Council are satisfied on inquiry, with respect to any Regulation, that the same is of too restrictive a character, or otherwise objectionable, and direct the revocation thereof, the same shall not come into operation, or shall thereupon cease to operate, as the case may be.

*Existence of Disease among Cattle.*

15.† If at any time disease ‡ exists among the cattle in a dairy or cowshed, or other building or place, the milk of a diseased cow therein—

- (a) Shall not be mixed with other milk ; and
- (b) Shall not be sold or used for human food ; and
- (c) Shall not be sold or used for food of swine, or other animals, unless and until it has been boiled.

*Acts of Local Authorities.*

16. (1) All Orders and Regulations made by a Local Authority under the Dairies, Cowsheds and Milkshops Order of July, 1879, or any Order revoked thereby, and in force at the making of this Order shall, as far as the same are not varied by or inconsistent with this Order, remain in force until altered or revoked by the Local Authority.

---

\* Altered by the Dairies, Cowsheds and Milkshops Amending Order, 1886 (see later, p. 701).

† Altered by the Dairies, Cowsheds and Milkshops Order of 1899 (see p. 702).

‡ The term 'disease' here only includes those recognised as such under the Diseases of Animals Act (see p. 480).

(2) Forms of Registers and other forms which have been before the making of this Order prepared for use by a Local Authority under the Dairies, Cowsheds and Milkshops Order of July, 1879, or any Order revoked thereby may be used, as far as they are suitable for the purposes of this Order.

*Scotland.*

17. Nothing in this Order shall be deemed to interfere with the operation of the Cattle Sheds in Burghs (Scotland) Act, 1866.

This Order was amended by the Local Government Board in 1886, and omitting recitals is as follows :

THE DAIRIES, COWSHEDS AND MILKSHOPS AMENDING ORDER, 1886.

Now therefore, We, the Local Government Board, in pursuance of the powers vested in Us by the Act of 1886, hereby Order as follows :

Article 1.—This Order may be cited as ‘The Dairies, Cowsheds and Milkshops Amending Order of 1886.’

Article 2.—Article 14 of the Order of 1885 shall be altered by the substitution therein of the words ‘Local Government Board’ for the words ‘Privy Council’ occurring therein.

Article 3.—If any person is guilty of an offence against the Order of 1885, he shall for every such offence be liable to a penalty of five pounds, and in the case of a continuing offence to a further penalty of forty shillings for each day after written notice of the offence from the local authority.

Provided, nevertheless, that the justices or court before whom any complaint may be made, or any proceedings may be taken in respect of any such offence, may, if they think fit, adjudge the payment as a penalty of any sum less than the full amount of the penalty imposed by this Order.

Article 4.—In this Order the expression ‘local authority’ means—

In the City of London and the Liberties thereof, the Mayor and Commonalty and Citizens of the City of London, acting by the Mayor, Aldermen, and Commons of that City in Common Council assembled :

In the Metropolis, except the City of London and the Liberties thereof, the Metropolitan Board of Works :

Elsewhere than in the Metropolis, the Urban or Rural Sanitary Authority.

Given under the Seal of Office of the Local Government Board, this First day of November, in the year One thousand eight hundred and eighty-six.

The next Order issued by the Local Government Board was at the instigation of the Tuberculosis Commission, which asked that *all diseases of the udder* might be scheduled. In the following Order only Tuberculosis of the Udder is made a 'disease' for the purpose of the Act :

THE DAIRIES, COWSHEDS AND MILKSHOPS ORDER OF 1899.

(*The recitals are omitted.*)

Now therefore, in pursuance of the powers vested in Us in that behalf, We hereby Order as follows :

Article 1.—This Order may be cited as 'The Dairies, Cowsheds and Milkshops Order of 1899.'

Article 2.—Article 15 of the Order shall be altered so that, for the purposes of the provisions of paragraphs (a) and (b) thereof the expressions in the said Article which refer to disease shall include, in the case of a cow, such disease of the udder as shall be certified by a veterinary surgeon to be tubercular ; and the Order and the Amending Order shall apply and be construed with the modifications necessary to give effect to this Article.

Given under the Seal of Office of the Local Government Board, this Seventh day of February, in the year One thousand eight hundred and ninety-nine.

In reviewing these Orders there can be no doubt that if fully exercised, and not rendered merely 'adoptive,' a very great improvement in the milk-supply would result. But, as expressed by the Royal Commission on Tuberculosis—which had every possible available evidence and information at hand—'from the evidence which we received, the Order would seem in some places to be a dead letter, and in the districts where it is enforced no attempt is made to obtain uniformity of practice.'

*The Infectious Diseases (Prevention) Act, 1890*, is a permissive measure, adopted by enlightened local authorities. Where it is law Section 4 authorizes the inspection of dairies in certain cases, with power to prohibit the supply of milk. Section 4 runs as follows :

In case the medical officer of health is in possession of evidence that any person in the district is suffering from infectious disease

attributable to milk supplied within the district from any dairy situate within or without the district, or that the consumption of milk from such dairy is likely to cause infectious disease to any person residing in the district, such medical officer shall, if authorized in that behalf by an order of a justice having jurisdiction in the place where such dairy is situate, have power to inspect such dairy, and if accompanied by a veterinary inspector or some other properly qualified veterinary surgeon to inspect the animals therein, and if on such inspection the medical officer of health shall be of opinion that infectious disease is caused from consumption of the milk supplied therefrom, he shall report thereon to the local authority, and his report shall be accompanied by any report furnished to him by the said veterinary inspector or veterinary surgeon, and the local authority may thereupon give notice to the dairyman to appear before them. . . . Any person refusing to permit the medical officer of health on the production of such order as aforesaid to inspect any dairy, or if so accompanied as aforesaid to inspect the animals kept there, or after any such order not to supply milk as aforesaid has been given, supplying any milk within the district in contravention of such order, or selling it for consumption therein, shall be deemed guilty of an offence against this Act.

The London Act contains similar provisions to the above, while the Act in Scotland, to which we will presently allude, has more comprehensive powers.

The chief blot in this legislation is the delay necessitated by legal formalities, while the penalties are far too small. It should be rendered obligatory for every dairyman to supply the medical officer of health with a list of his customers, while for both veterinary and medical reasons he should be compelled to disclose all his sources of supply.

Under the Public Health (Scotland) Act, 1897, the local authority may compel a dairyman to supply information, and produce a list of customers and invoices, if the medical officer has evidence that any person is suffering from an infectious disease attributable to milk.

If the incriminated dairy is situated outside the district the medical officer acts for, no legal delay results, as he has only to report to the local authority of the district in which the dairy is situated, and they are then compelled to send a veterinary and medical officer to inspect and report.

The Local Act in Glasgow (Glasgow Police Amendment Act, 1890) enables the Police Commissioners to inspect all cows kept for supplying milk within their jurisdiction, and to proceed against the owner if he retains any cow which suffers from tuberculosis, or any disease which might render the use of such milk dangerous or injurious to health. The same powers of inspection are extended to all byres outside the city, whence milk is brought for sale within the city, but the Tuberculosis Commissioners in reference to this said there were obvious difficulties in the way of exercising these powers, and that at the date of their Report they had not been put in force.

Certain cities have obtained special Acts of Parliament to deal with the question of tuberculosis and milk-supply. The following is that of the City of Manchester, which was the first in 1899 to obtain powers in private Bills for this purpose, since which date numerous towns have followed the excellent example set them.

By the Manchester Corporation (General Powers) Act, 1899, it is enacted as follows :

19.—(2) Every person who knowingly sells or suffers to be sold or used for human consumption within the city the milk of any cow which is suffering from tuberculosis of the udder shall be liable to a penalty not exceeding ten pounds.

(3) Any person the milk of the cows in whose dairy is sold or suffered to be sold or used for human consumption within the city who after becoming aware that any cow in his dairy is suffering from tuberculosis of the udder keeps or permits to be kept such cow in any field shed or other premises along with other cows in milk shall be liable to a penalty not exceeding five pounds.

(4) Every dairyman who supplies milk within the city and has in his dairy any cow affected with or suspected of or exhibiting signs of tuberculosis of the udder shall forthwith give written notice of the fact to the medical officer stating his name and address and the situation of the dairy or premises where the cow is. Any dairyman failing to give such notice as required by this sub-section shall be liable to a penalty not exceeding forty shillings.

(5)—(A) It shall be lawful for the medical officer or any person provided with the authority in writing of such medical officer to take within the city for examination samples of milk produced or sold or intended for sale within the city.



(B) The like powers in all respects may be exercised outside the city by the medical officer or such authorized person, if he shall first have obtained from a justice having jurisdiction in the place where the sample is to be taken, an order authorizing the taking of samples of the milk which order any such justice is hereby empowered to make.

(6)—(A) If milk from a dairy situate within the city is being sold or suffered to be sold or used within the city the medical officer or any person provided with and if required exhibiting the authority in writing of the medical officer may if accompanied by a properly qualified veterinary surgeon at all reasonable hours enter the dairy and inspect the cows kept therein, and if the medical officer or such person has reason to suspect that any cow in the dairy is suffering from tuberculosis of the udder, he may require the cow to be milked in his presence and may take samples of the milk, and the milk from any particular teat shall if he so requires be kept separate and separate samples thereof be furnished.

(B) If the medical officer is of opinion that tuberculosis is caused or is likely to be caused to persons residing in the city from consumption of the milk supplied from a dairy situate within the city or from any cow kept therein, he shall report thereon to the Corporation and his report shall be accompanied by any report furnished to him by the veterinary surgeon, and the Corporation may thereupon serve on the dairyman notice to appear before them within such time not less than twenty-four hours as may be specified in the notice to show cause why an order should not be made requiring him not to supply any milk from such dairy within the city until the order has been withdrawn by the Corporation.

(c) If the medical officer has reason to believe that milk from any dairy situate outside the city from which milk is being sold or suffered to be sold or used within the city is likely to cause tuberculosis in persons residing within the city the powers conferred by this sub-section may in all respects be exercised in the case of such dairy provided that the medical officer or other authorized person shall first have obtained from a justice having jurisdiction in the place where the dairy is situate an order authorizing such entry and inspection, which order any such justice is hereby empowered to make.

(D) Every dairyman and the persons in his employment shall render such reasonable assistance to the medical officer or such authorized person or veterinary surgeon as aforesaid as may be required by such medical officer person or veterinary surgeon for all or any of the purposes of this sub-section, and any person refusing such assistance or obstructing such medical officer person or veterinary surgeon in carrying out the purposes of this sub-section shall be liable to a penalty not exceeding five pounds.

*Examination of Milk.*

The chemical and bacteriological examination of milk for human food falls to the Medical Officer of Health; but quite apart from that, it is desirable for veterinary purposes that an independent examination should be made. While the Medical Officer of Health deals with it as a food, we examine it as a secretion, and whereas he causes his analysis to be made with material removed from the milk-can, the fluid we examine is taken direct from the gland.

Assuming that an examination is made by the Medical Officer of Health of the mixed milk of the dairy, and by the Veterinary Officer of Health of the secretion of a single cow, the results will by no means agree, even when the analyses are made by the same hand. The mixed milk of a dairy is of such uniform composition that adulterations are readily detected, while the secretion from a single cow may differ considerably from that of the mixed milk.

An examination of milk should be both chemical and microscopical. The chemical should deal with the specific gravity, reaction, total solids, fat, and the solids not fat. A table has been drawn up representing the *minimum* quantity of these found in a genuine sample of 'mixed' milk, viz.: Total solids, 11·5 per cent., consisting of—fats, 3 per cent., solids not fat, 8·5 per cent.

A milk containing less than these, is regarded under the Food and Drugs Act, 1875-1899, as not genuine until the contrary can be proved.

The average composition of mixed milk, obtained from the examination of some thousands of specimens, is as follows:

Water ...	...	...	...	Average.	...	87·34
Total solids	...	...	...	...	...	12·66
						100·00
Total solids	...	{	Fat	...	...	3·722
			Solids not fat	...	...	8·938
Solids not fat	...	{	Casein and albumin	...	...	3·594
			Milk sugar	...	...	4·614
			Ash	...	...	0·730

There are various causes which influence the composition of the secretion, which in the examination of a single sample would have to be borne in mind. For instance, the first portion of milk drawn from the udder is more watery than the last; in fact, during the whole process of milking there is a gradual increase in the total solids, more noticeable, however, in the fat constituent than in the solids not fat.

The morning milk usually contains from  $\frac{1}{2}$  to 1 per cent. more water than the evening milk, or to state the case another way the evening milk is richer than the morning. There is also a difference in the composition depending upon whether the animal is milked twice or three times a day; in the latter case the fat is higher than in the former.

The age of the cow is not without influence, the maximum amount of milk produced is generally between the fourth and fifth calf. A large yield of milk may, but not necessarily, mean a milk of poor quality. Breed is of the utmost importance in the composition of milk; in the Jersey, for example, the milk is very rich, in fact, comparing the Jersey with another excellent milking breed, viz., Ayrshire, there may be as much as 2 per cent. more fat and 2 per cent. less water in the milk of the former as compared with the latter.

The period of lactation is another factor to bear in mind, and here the fat is the main constituent affected. Taking the average period of lactation at about 300 days, it is found that practically there is throughout the whole of this time a gradual increase in the amount of fat secreted.

Diet also influences the composition of the secretion; one deficient in proteids produces a poorer milk than a diet in which this exists in proper proportion. It is considered by some that the influence of diet is not so marked as the influence of breed; but the influence of good feeding on the quantity and quality of the milk is extraordinary. Regularity in milking and kind treatment are both factors which influence the composition of the secretions.

The milk secreted for a few days after calving is, of

course, quite distinct from ordinary milk both in colour and composition.

The milk should be inspected in a tall glass measure, by which its colour can best be observed, while any deposit can be secured for microscopical examination.

The reaction of normal milk is alkaline, but some specimens may give both an acid and alkaline reaction, due to the presence of acid phosphates and carbonates of the alkalis. By warming the milk the alkaline reaction is rendered more pronounced, but it has no effect on the acid reaction.

The specific gravity varies from 1030 to 1033, but this presupposes that the temperature at which the examination is made is 60° F. Roughly speaking, a rise of ten degrees above 60° F. corresponds to a fall of one degree in the specific gravity. A correction has therefore to be made for temperature, unless the milk is warmed or cooled to the required degree. A lactometer is generally employed to ascertain the specific gravity, but greater accuracy can be obtained by the use of the specific gravity bottle.

The specific gravity may be higher or lower than that given above, which are the means of a large number of observations of mixed milk: that from single cows is more liable to variation, and may be as low as 1026 or as high as 1038.

The specific gravity is often used as a test of adulteration; fat has a lower specific gravity than water, and the solids not fat have a higher. A high specific gravity may mean the milk has had its fat removed. A low specific gravity might mean either that water had been added to the milk, or on the other hand, that it was unusually rich in fat. No definite statement can be based on the specific gravity alone.

The total solids can only be obtained by evaporating a definite amount of milk, and drying it for some hours at 212° F. until the weight becomes constant.

The fat in milk exists as an emulsion, and on standing rises to the surface as cream, of which there may be from

8 to 10 per cent. by bulk in ordinary milk, or very much higher, as in the case of certain breeds of cattle. One part of cream corresponds roughly to 0·2 of fat.

To ascertain the amount of fat in milk, a definite quantity of the fluid after well mixing so as to distribute the oil globules, is dried as above, and the fat extracted by ether in a special apparatus. It is then weighed after thorough drying.

The dried milk from which the fat has been extracted may be carefully incinerated, and the amount of ash thus obtained weighed.

The fat may be ascertained by Babcock's method which is very simple. A known bulk of milk is introduced into a special tube with a narrow graduated neck; sulphuric acid is added and the mixture centrifugalized, which causes the fat to collect in the neck where the amount can be read off.

The above simple analysis gives the total solids in the milk, the fat, ash, and the solids not fat. Beyond that it is hardly necessary to go; the determination of any alteration in the proteids of milk might be desirable information in udder disease, but would be a much more complex proceeding than the above; alterations, on the other hand, in the proportion of sugar are readily determined by Fehling's Solution.

#### *Sources of Contamination.*

The microscopical examination of milk should normally only reveal the milk globules, but epithelium, hair, and fragments of vegetable fibre are met with in milk which is not pathogenic. The epithelium is derived from the teats, the hair from the udder, and the vegetable fibre from anything which has dropped off the udder into the pail, ranging from fragments of food to portions of fæces. In pathogenic cases blood and pus cells and casts of the milk-ducts may be seen microscopically.

Whether the milk be normal or pathogenic, innumerable organisms may be seen by allowing it to stand sufficiently

long to admit of their growth and multiplication. These organisms are associated with changes in the milk, and are of normal occurrence; but in pathological milk micrococci and streptococci may be seen, while under highly favourable circumstances the bacilli of tuberculosis may be identified.

Milk being an admirable culture medium, many kinds of organisms may be found, quite irrespective of the state of health of the animal from which the secretion has been derived; calculations have shown that as many as 400,000 per cubic centimetre of milk are common.

The number of micro-organisms depends on the age of the milk examined; the older it is the more numerous the microbes, none of which may be pathogenic but all of which indicate contamination.

The colon bacillus if present is generally selected by the medical expert as evidence of contamination with cow dung, and it may be so. Such contamination if derived from the cow, could not possibly be productive of disturbance in man. But the colon bacillus may have a human origin, and as such may not be above suspicion. Medical officers who blame cow excreta for the existence of the colon bacillus, should not forget that it is much more readily obtained from the human hand, and carried into the milk in the detestable practice of wetting the fingers during milking, by introducing them into the pail.

No effort of imagination is required to understand how milk contamination from human sources may arise, when the careless and dirty habits of those in attendance on cows are known. The veterinary profession sees a side of the picture that rarely comes within the view of the medical officer, and the consensus of opinion is that in spite of advancing civilization and knowledge, matters are worse in the cow-house at the present day, so far as the personal cleanliness of the milker is concerned, than they were years ago.

The place formerly occupied by women is now largely taken by men. All farm employés, irrespective of the state

of their clothing, hands, and occupation, are called upon to assist in milking the cows, and the remarkable thing is that more trouble does not arise from this practice than we hear of. Medical Officers of Health will do well to carefully examine into this serious source of contamination before blaming the cow.

There are several fermentations known to occur in milk outside the body, some of which are destructive of the fluid, while others are turned to useful advantage in the dairy.

There are over one hundred different kinds of lactic acid organism known; the lactic acid is produced by the action of the bacterium on the sugar of milk. The most favourable temperature for its production is 60° F., which is the explanation why milk should be cooled on withdrawal from the body, for the more rapidly it is cooled the longer it will keep.

The lactic acid organism can also be destroyed by raising the temperature of the milk to 158° F., so that two opposite conditions effect the same result, so far as the organism is concerned, viz., cooling or heating.

Lactic acid fermentation is capable, so it is said, of liberating, under certain conditions, some very poisonous products from the casein of milk, which have played an important part in ice-cream poisoning of man.

The butyric bacillus is concerned in butyric fermentation, which breaks down both the casein and milk sugar.

The viscosity of some milk, which is frequently a pathological condition, may also occur after the milk has been drawn from the body, and is due to several organisms of which eighteen varieties are known to exist. It is also well to remember that special kinds of food may produce the same condition, such as tares and 'butter-wort'; the latter is in Norway purposely introduced into the milk, in order to produce a ropy condition which is much appreciated.

When viscosity occurs in milk on standing, it is practically always due to infection from without, dirt in the vessels or dairy, and not due to the cow.

Bitterness in milk is due to an organism acting as a ferment on the proteids of milk, and producing peptone and other products of proteid change, to which in all probability the bitterness is due. The hay bacillus can, it is said, bring about this change.

Alterations in milk affecting its colour are also known to result from organisms; thus blue milk results from the action of the *Bacillus cyanogenus*, a change which occurs in milk on standing, and in which the presence of lactic acid is an essential. Red milk may be due to *Micrococcus prodigiosus* or other pigment-forming bacteria. Yellow-milk is caused by the *Bacillus synxanthus*. In addition to the above, green and violet pigments in milk are found as the result of bacterial action.

None of these organisms exist in the milk when drawn from the body, but are the result of subsequent contamination.

Milk may readily be affected by powerfully smelling substances in the food (see pp. 135, 159, 183, 184, 262), turnips being perhaps the most common cause of taste. Besides this it can absorb odours from without, such as may be met with in badly ventilated cow-sheds or defective dairies, or from the use of carbolic acid as a disinfectant, or the presence of ensilage in the cow byre. The capacity milk possesses for absorbing gases or volatile substances is remarkable, in this respect it has been likened to a sponge; hence the necessity for the most thorough hygienic surroundings in the cow-shed and dairy.

#### *The Care of Milk.*

The care of milk essentially belongs to the medical officer; but it is important that our knowledge of this matter should be equal to his, for the cow may be blamed when the fault lies with the man. Still, we fully recognise that the care of milk, its storage, distribution, and sale, come entirely within the duties of the Medical Officer of Health, as completely as the cow and cow-house belong to us.



We can leave bacteriologists to settle the question of whether milk drawn from the udder is germ free. It is quite certain from the moment it enters the milk-pail it is infected ; this infection may result from the air of the cowshed, from the hands of the milker, the dirt, hair, etc., from the udder of the cow, and from want of cleanliness in the vessels used for milking.

All of these are more or less under control ; the proper care of the air of the building has been fully considered in previous pages. The other sources of infection may now be dealt with.

The ill effects milk may produce on man are not, with the exception of tuberculosis, due to anything derived from the cow, but to the hands or clothing of the milker, or to contact with those persons charged with the preparation and delivery of milk.

All milk epidemics, be they enteric, scarlet fever, diphtheria, or sore throat, may safely be attributed to human contamination. Considering the number of hands and sources of infection that milk is exposed to through human agency, from the moment it is propelled into the pail until it reaches the consumer, the unprejudiced observer will readily recognise the attitude adopted by the entire veterinary profession on this question. The position taken up has been quite unshaken by twenty years' efforts to saddle the cow with producing the above specific diseases in the human subject.

That dirt from the cow finds its way into milk is undoubted, the quarters and udder are often filthy, the most elementary care is frequently not observed. Cows in their standings are not kept clean, the flooring is not arranged so as to carry their excreta away from their bodies ; they are prevented from licking themselves by being packed two in a stall ; they are not groomed, and at pasture they are allowed to wallow in filth. It is therefore no wonder that dirt from their bodies finds its way into the milk.

But look also at the milker, little if any cleaner ; his clothing is dirty, his hands and nails filthy, his habits

often insanitary, and while he is the subject of the very diseases which milk is capable of distributing, the cow is immune to them. An immense amount of good solid work has been done by the medical profession to improve the cleanliness of milk-supply, but more yet remains; they must regulate the milker; he, at least, must be above suspicion, both in his general health and cleanliness. An ample supply of water and facilities for washing must form part of every dairy equipment; soap and nail-brushes are essentials, and supervision to insist on their use. Special clothing should also be employed during milking. Given these conditions, with a proper system of distribution, we should hear no more of milk epidemics.

Cleanliness of the udder and teats of the cow come next in importance; it has been suggested to wash these with soap and water, but perhaps it would be quite sufficient, and in practice infinitely more suitable, if the teats and udder were wiped with a clean cloth.

The cleanliness of the milk vessels has been assumed, facilities should exist for sterilizing them daily. The milk having been obtained, should at once be removed to the dairy, where it is strained and cooled and is then ready for delivery to the retail seller.

Even assuming it has left the dairy moderately germ free, as soon as it passes into retail hands a fresh cycle of possible contamination has to be risked. Dirty vessels, dirty hands; the man on his 'round' keeps dipping his hands into the can in the process of measuring, hands that could not be above suspicion even if he started his rounds with them surgically clean!

Take, again, the milkshops in the poorer parts of crowded cities, where the sale of milk is mixed up with tobacco, paraffin, fish and vegetables!

It is, indeed, utterly incomprehensible that all these sources of infection should have had so little real importance attached to them, while a hairless patch on the cow has been credited as the local indications of cow scarlatina!

It is to guard against the sources of infection, which

under the existing defective system cannot be prevented, that the consumer is invited to Pasteurize his milk ; or in other words, to raise its temperature to that point (158° F.) which will not give it a cooked taste, and yet sufficiently high to destroy, at any rate temporarily, most of the common organisms. If he wishes to destroy both common and pathogenic organisms, he should raise it to 212° F. for a few minutes.

As a matter of fact the day must come when all milk will have to be delivered 'put up,' so that the extra chances of infection resulting from the 'rounds' of the retail tradesman may be avoided. Jars can now be had made in all sizes from half a pint upwards with a germ proof cover, and the milk delivered without being exposed to infection from the time it leaves the dairy until it reaches the consumer. On the next round the jars are collected, washed, steamed, and sterilized, and again ready for issue.

For the poorer classes it is quite likely Municipalities will have to take over the milk-supply, already a step has been taken in this direction by one or two places, where milk for infants can be obtained which is above suspicion.

The milk-supply of towns is a purely medical question, though it has received capable handling by the veterinary profession.\* In the reference given, Lloyd mentions among other reforms, (1) An increased price must be paid for a better and purer article. (2) He urges municipalities to encourage the milk producer to extend greater cleanliness to everything connected with his trade. (3) Local authorities are begged to apply the powers they already possess, in the shape of the Dairies, Cowsheds, and Milkshops Order. (4) The supply of milk from any cow suffering from illness

\* 'The Milk-Supply of Large Towns': Mr. J. S. Lloyd, F.R.C.V.S., *Journal of State Medicine*, vol. xii., No. 1, 1904; 'Collection, Distribution, and Contamination of Milk': Mr. J. Brittlebank, M.R.C.V.S., *Journal Sanitary Institute*, vol. xxiv., part iv., 1903; 'Some Points on the Hygiene of the Udder, and the Conditions of Milk Production in Rural Districts': Mr. J. Harvey, F.R.C.V.S., *Royal Institute of Public Health, Exeter Meeting*, 1902.

should be rendered an offence. (5) To rigidly apply the law relating to Adulterations. (6) Municipalities are asked to certify the milk from dairies conducted on hygienic principles. And finally, (7) The establishment of municipal milk depôts is demanded for the supply of milk for the children of the poorer classes.

To these recommendations none can object, they are in accord with common-sense and experience, but their aspect is almost entirely medical.

It is quite possible one source of milk contamination will in course of time be abolished, and that is the milker. The milking of cows by machinery is an accomplished fact, and will in the course of years take the place of the person who at present is chiefly responsible for milk epidemics; such a system combined with the bottle method of delivery, will insure a perfectly sound food being placed in the hands of the consumer.

#### KNACKERIES.

The chief use of a knackery is the disposal of dead animals, or the destruction of those diseased or infirm. It particularly applies to horses, but other animals, though in far smaller numbers, find their way there.

It was a mistake to include knackeries under the expression 'slaughter-house' as defined by Section 4 of the Public Health Act of 1875, as in this way two totally distinct institutions became mixed up; into a slaughter-house there enters nothing which is not alive and, at least in theory, free from disease; whereas into a knackery dead and living animals are admitted, in all cases the subjects of disease or incapacitated for further work. It would have been far better to have included knackeries under offensive trades, and have kept this repulsive and offensive calling quite distinct from food production.

Knackeries have received insufficient attention at the hands of Sanitary Authorities, and the present state of affairs has recently received at the hands of the veterinary profession very exhaustive and advanced consideration.

Shaw\* points out that owing to the trade depreciation of the various products derived from knackereries, the question of the disposal of the dead animals from cities must sooner or later receive increased attention at the hands of Sanitary Authorities. During the last twenty years the commercial value of the products have depreciated fifty per cent., and it is possible within the next twenty years nothing but the hide may possess any value. The reasons for this opinion are given by Shaw in detail, some of which we reproduce. The sale of salted horse meat to the Continent is now prohibited, and has consequently decreased the value of the carcasses of such animals by one-half. Nothing is now sent to the Continent excepting in a live condition, and the restrictions on this export trade reduce the number to 8,000 a year from the Port of London. Should further restrictions be made, the whole of the animals will have to be disposed of in England, and at present the taste for horse-flesh has not developed.

The number of carcasses dealt with yearly in London by knackers is about 28,000 horses and cattle, besides a number of smaller animals such as sheep, goats, and pigs; what the trade amounts to in the whole of England is unknown, for as there is no horse census so also there is no death registration.

Mr. Shaw very properly calls upon Sanitary Authorities to municipalize knackereries, and so place them under effective control; he tells us from his experience in London, that he does not know of one which is conducted without causing a nuisance to the immediate neighbourhood.

As private concerns paying very reduced dividends, it is possible that if municipalities insisted on costly reconstruction, or changes involving further trade loss, these places which are at present voluntary might be compelled to close. The resulting state of affairs in towns and cities, especially during the summer, would then call for urgent

\* 'The Disposal of Dead Animals from a Sanitary Point of View': Mr. W. F. Shaw, F.R.C.V.S., Congress of the Sanitary Institute, Bradford, 1903.

and immediate action, which municipalities would do well to anticipate.

The following suggestion made by Shaw is worthy of their careful attention, viz., the purchase of all existing knackers' yards, their reconstruction, and leasing to properly qualified persons under rigid restrictions, or even worked by the municipality itself. There are other alternative suggestions made by the same authority, but they do not appear to us to be so practically useful as the above, nor to afford the same sanitary control.

Speaking broadly, from a public point of view a knackery is a place for the destruction of horses, and the reception of all dead animals; from a private point of view it is a place where the money paid for the collection of the dead, or of the living for destruction, may be recovered and as large a profit as possible obtained on the investment.

This profit is obtained by the sale of the various parts of the body used in trade, all of which are capable of being turned to useful advantage; the hide, flesh, bones, blood, fat, feet, hair, etc., have all an economic value, which, as Shaw shows, is gradually getting less, but still at present furnishes sufficient profit to carry on the trade as a voluntary concern.

A knackery should also be a place where the bodies of animals dead from or destroyed from infectious disease may be destroyed either by fire or chemical means, so as to prevent the spread of infection. For this purpose an incinerator should form part of the equipment of every well organized establishment, for there are bodies received into these places in such a state of putrefaction as to render the flesh quite unfit for utilization; this is especially the case in deaths from acute bowel or chest trouble in horses, especially if any time has elapsed since death occurred.

It is only those whose profession brings them in daily contact with the sick, dying, and dead who can realize to the full what this really means.

If the human body would only putrefy and smell with the same rapidity as that of herbivora, funeral reform

would receive considerable assistance. No medical man called upon to legislate on this subject, which essentially belongs to the veterinary profession, can form any notion of the rapidity of putrefactive changes in the herbivora. Shaw rightly proposes that a penalty should be attached to keeping dead animals on the premises longer than is absolutely necessary for their removal; but this is also a matter for the education of the public, who should be instructed that there is a vast difference between the keeping powers of a human cadaver and that of a horse or ruminant.

The sanitary aspect of this question is twofold, for not only does air-poisoning occur of the premises where the death took place, but it is this class of carcase which adds so seriously to the nuisance of a knacker's yard.

We know, of course, that the disembowelment of such a case delays putrefactive changes for some little time, but it is doubtful how far this simple procedure is capable of general application.

Knackeries from their very nature are offensive, but this is intensified by the want of cleanliness and care shown; bones, fat, blood, viscera, hides, hair, and so forth in various stages of change are practically always met with. The boiling processes take place in the slaughtering department; the air is saturated with moisture, and the odour of cooked flesh, a good deal of which is far from above suspicion, pervades the place, while the fat and decaying bones lend a penetrating smell which is most difficult to get rid of even in the open air.

That portion of the premises where animals are actually destroyed, should be fitted up on the same sanitary principles as an ordinary abattoir as regards lighting, ventilation, drainage, water-supply, impervious flooring and walls, for which see p. 656.

The flesh boiling process, and that of fat extraction, if practised, should be in a separate place, and carried out under conditions which produce as little effluvia as possible. Cooking operations should be effected in steam-

jacketed vessels, instead of open pans where the fire plays direct and offensive steam is generated. If pans be used they must be capable of closing, while the vapours should pass out through a special flue, and be conducted through the fire chamber, where they are destroyed by combustion.

The liberal use of disinfectants suggests itself in knackeries, but there must be a limit to their applicability; in the case of flesh it might render the surface poisonous or unsaleable, and the other products might conceivably not be improved from a manufacturer's point of view, by liberal dosing with crude carbolic acid.

But there is no reason why this should not be practised as a routine method to walls and flooring, as often as possible during the week.

There should be a time limit for stale bones, fat, blood, and offal generally; all these should be placed in air-tight galvanized vessels for removal to the manufacturer's; hides should not be allowed to accumulate but rapidly passed on to the tanner.

Such are the hygienic conditions which are necessary, and more frequently than not unattainable. A knackery is not like an abattoir where definite working hours exist, with definite days for slaughtering; the knacker's work is continuous seven days a week and often day and night, so that opportunities for a general clean down are not frequent.

Cleanliness should be the keynote, the early removal of all offal and manure is the first step in this direction. The separation of the cooking apparatus from the slaughterhouse should be insisted upon, as the high temperature generated by the furnace and boiler are both detrimental to the preservation of the tissues. Overcrowding should be avoided, a given area will only accommodate a certain number of workers; the sanitary limit of each institution should be determined by the floor space, the number of men employed, and the number of hours throughout the twenty-four during which work goes on. By increasing the floor space better sanitation would be possible.

It is convenient here to briefly consider the method by



which horses may be destroyed in the most humane manner. As they are more used to be handled than cattle, and the head assumes a different position, there is seldom any difficulty in expert hands in carrying out destruction quite painlessly, either by the pole-axe or by Greener's Patent Killer which fires a bullet.

It is otherwise in the hands of the nervous or inexperienced, especially where firearms are employed. For the safety of all concerned no firearm, excepting the above, should be employed in a crowded place, and even with it the bullet may at times be deflected and come out. On the whole, Greener's 'Killer' is as safe as firearms can ever be, and a cool inexperienced man can under competent directions carry out destruction with perfect success.

On the other hand, the pole-axe can only be wielded by an experienced hand, and the least movement of the head may be attended by untoward results.

Whether bullet or pole-axe be employed the spot selected should be the bottom of the forelock, at which position no failure to kill painlessly is possible; the inexperienced always aim too low. When a rifle is employed it is a source of danger to anyone within 1,000 yards; in consequence a shot gun should always be used by the inexperienced when the 'Killer' is not available.

Public opinion will shortly demand some better arrangement for the conveyance of the dead than the repulsive and insanitary knacker's cart. It is a disgusting sight with the dangling head in front, blood dripping from the nostrils, body fluids or blood running over the tail of the cart, with moreover everything exposed to view.

A proper sanitary watertight cart, preferably of metal, should be used, and the whole carcase hidden from view. Until such a cart is devised, and there are constructional difficulties, the local authorities should enforce a sheet being employed to hide every portion including the legs of the carcase from view, with a bag in which the entire head is placed.

As many animals suffering or dead from contagious

diseases are sent to the knackeries, a careful registration of all animals and carcasses is essential, as well as a regular and frequent inspection by the Inspector under the Contagious Diseases Animals Act. By adopting these measures many outbreaks of contagious diseases are successfully traced, and their eradication rendered more easy.

MARKETS.

By Section 167 of the Public Health Act, 1875, an Urban Authority may make with respect to any market belonging to them, byelaws for any of the purposes mentioned in Section 42 of the Markets and Fairs Clauses Act, 1847.

The portion of Section 42 which has a veterinary aspect deals with pens and standings, and for preventing nuisances in connection with them.

The following byelaws on this question are suggested by the Local Government Board.

7. A person who shall use any pen for the reception of any cattle brought into the market place for the purpose of sale, or of exposure for sale, shall not place or allow to be placed in such pen a greater number of cattle than shall be compatible with the allowance in respect of the several animals placed in such pen of an extent of superficial space\* to be determined in accordance with the following regulations :

	Feet.	Inches.		Feet.	Inches
For every horse a space not less than	"	"	by	"	"
For every ox or cow a space not less than ... ..	"	"	by	"	"
For every mule or ass a space not less than ... ..	"	"	by	"	"
For every calf a space not less than	"	"	by	"	"
For every ram, ewe, wether, lamb, goat, kid, or pig a space not less than ... ..	"	"	by	"	"

\* The following requirements have been suggested as generally suitable :

For every horse, 8 feet by 2 feet. For every ox or cow, 8 feet by 2 feet. For every mule or ass, 5 feet by 15 inches. For every calf, 5 feet by 15 inches. For every sheep, goat, or pig (of medium size), 4 feet (superficial).

The hygiene of the market or fair is a most important veterinary consideration. Markets are the chief means of spreading animal diseases throughout the country. Their inspection and thorough disinfection under veterinary supervision would greatly control this source of distribution; disinfection can never be left to lay management.

The following Order, which is a great advance on anything previously directed, will, if enforced, be of considerable benefit :

Under the *Markets and Sales Order of 1903*, which came into operation June, 1904, the Board of Agriculture directs that a market or sale of cattle, sheep, goats and swine shall not be held in any market-place, sale-yard or other premises, until eight days from the date on which the premises were last used for this purpose have expired, unless the place is paved with cement, concrete, asphalt, or other material impervious to water so as to permit effectual cleansing by washing. This article does not apply to the holding of any fair on two or more consecutive days.

Any market or other place where sales are habitually held shall before being used again be cleansed and disinfected as follows :

The premises shall be thoroughly scraped or swept, and such parts that permit of washing shall be so cleansed. After cleansing the premises are to be thoroughly sprinkled with lime-wash containing not less than five per cent. of carbolic acid. All pens, hurdles, and fittings shall be cleansed by scraping, washing, and sprinkling with the above mixture of lime-wash and carbolic acid before being again used.

All scrapings and sweepings are to be mixed with quicklime, and effectually removed from contact with animals.

The cleansing and disinfection is to be carried out by the person in occupation, and in any other case by the local authority of the district.

It is an offence to hold a market or sale in contravention of this Order, or to neglect cleansing or disinfection.

This Order revokes all regulations on this subject made by a local authority under any previous order of the Board.

## CHAPTER XIII

### THE CARE AND MANAGEMENT OF ANIMALS

THE subject of this chapter has formed the text of many works, and deservedly so from its extreme importance. While, therefore, giving due attention to all the principal points, and special details when we consider them necessary, yet it must not be considered that the question has been dealt with exhaustively.

The care and management of animals is really the practical application of the laws of hygiene and physiology, supplemented by those special details found necessary by experience. So vast is the subject that probably no one person is master of more than the details concerning one animal; hence we find that the care and management of horses, cattle, sheep, and pigs, are, generally speaking, separate and distinct callings, and certainly no one person could possibly lay claim to be an expert of the whole. As each animal is the study of a lifetime, we shall be compelled to draw on the best available sources for such special information as is outside our personal experience.

#### SECTION I.—THE HORSE.

This subject will be divided under three heads, viz., the care and management of horses in early life, in the stable and at work.

#### THE YOUNG ANIMAL.

*Early Handling.*—Horses are born wild. A recognition of this fact would save many in after life, for it points to

the necessity for early handling and domestication, at an age which is impressionable, when the lessons are soon committed to memory, and are permanent.

The present system of allowing young animals to have practically their own way for at least two years of their life, and often longer, is the cause of the existence of the so called 'breaker,' a term which is extremely appropriate.

There would practically be no need for such a person if the young animal could never remember when he first resented being handled; when to have a halter put on, his mouth looked at, feet picked up, legs handled, are as much part of his daily life as being watered and fed. Such an animal needs no breaking in the sense in which this term is generally applied; it is docile, tractable, obedient, confident, and on such a foundation any education can be imparted. Gain the confidence of a horse and everything else follows.

The young animal's lessons cannot begin too early, there is no reason why a week after birth a head collar should not be put on and the foal led about for a few minutes.

These leading lessons are most important; even the youngest animal resents them, but with kindness and firmness, it is possible within a very short time to get the foal to come up to have the head collar put on, and to follow a man about at the end of a rope without in the least resenting the temporary loss of freedom.

This is the first and great lesson to learn so far as the future usefulness of the animal is concerned; it is in the 'breaking' that so many tempers are ruined, and future unsoundness laid. With such a system as is sketched above, the animal is ready at two years old to have either harness or saddle put on without difficulty. The animal is in fact prepared for the final stage in its education, viz., a light man placed on its back, and obedience to the reins obtained.

The limbs and feet should be handled from the second week of birth, and the young animal taught not to resent the hands being passed over the body.

On no account should any part of this work be performed by boys; the temptation to tease is apparently irresistible, and the foal would grow up fidgety, flighty, and wanting in trust and confidence of the biped.

Weekly lessons of this kind lasting but a very short time may be given the whole time the foal is suckling, and should be continued as a regular routine throughout early life.

What a difference such an early upbringing would be to horses, with what confidence they would regard man, for ill-use or harsh words would never be required! Instead of this our present product is a nervous, irritable animal, frightened of its own shadow, frightened of everything which is strange, that resents a head collar, resents being handled, feet picked up or a hand passed over the body. In fact an animal that resents everything that restricts its freedom and the exercise of its own will.

On top of this irritable frame of mind has to come the lesson of carrying a man on its back, with all the attending exhibition of fear, excitement, and frequently temper later on.

The whole of these are practically abolished by the system laid down of handling all foals from the time they are born. What this simple system would add to their useful life cannot be overestimated, and would be the means of preventing a considerable amount of cruelty.

*Feeding.*—The feeding of foals is a matter of paramount importance, they should be induced to take both oats and hay long before the date of weaning arrives. A little may be placed on the ground for them when their dam is fed; if the corn is not scalded it should be crushed. In this way when the day of separation arrives, we have the feeling of certainty that though the foal may sulk as the result of separation, it, at any rate, will not starve.

If a foal is required to grow up strong and healthy it must be fed; the common practice adopted of giving very little more food than is required to keep the animal alive results in stunted growth and want of development.

The effect of liberal feeding may be seen in a two-year-old thoroughbred, which from its appearance might be taken for a four-year-old. Liberal feeding tends to bone and growth; wherever the nature of the country is such that feeding is scanty, or pastures bare for long periods in the year, in such places horses run small.

By good feeding horses could be brought into light work at an earlier age than is at present the case. Early maturity is now being looked for everywhere among animals, times move too quickly for the older process of slow development. Development is hastened by liberal feeding; in the case of sheep and cattle intended for the butcher, their value is in the pockets of their owners a year or eighteen months earlier than was the case a few years ago.

Whether forcing the maturity of the horse in order that he might be brought into work at say  $2\frac{1}{2}$  years instead of  $3\frac{1}{2}$  would be an advantage we are not at present prepared to admit, unless in the case of the man who understands he has bought a young horse and treats it accordingly. Such people are the exception. A man as a rule buys a horse to work; young or old makes little difference to the average individual so long as his work is performed. If it were pointed out that the horse should work only every other day, and then only short journeys and light loads, the response would be that it was not the class of animal the proposed owner was looking for.

We doubt the advisability of working horses too young, even though they have been liberally fed since birth, and the short artificial life led by the race-horse is no argument in favour of this practice. With animals which have been stunted in their diet it is entirely out of the question.

*Pasturing.*—The half-bred foal is weaned before the winter arrives, separated from the dam, and after a day or so of separation the mother and foal have equally forgotten to think of the matter. The foals should spend their winter outside with a simple form of shelter from the weather, but more particularly from the wind. It is not the rain, snow or frost which kills a well-fed animal, nor

do animals mind either snow or rain. It is frequently found in paddocks and straw-yards that they are standing away from the shelter during either of these, or even sleeping outside at night.

What they do not like is wind, and as protection against this they huddle together for warmth: for this reason shelter sheds in the paddock or straw-yard should be given animals. On no account should they be placed in a closed-in building, unless it is freely ventilated and doors and windows removed, for if these are left nothing can prevent them from being closed.

The mangers used in these sheds must be sufficiently low for the animal to feed in comfort, and sufficiently high to save his rather short neck. All the foals should feed together, but here the watchful eye of a foal attendant is required; one or more bullies will exist, and one or more subservient, weak charactered foals will in consequence suffer. Driven from the manger by the bullies, they suffer not only from emptiness but from kicks. Every kicker should be removed, and every bully banished; these must be fed by themselves, even if necessary kept by themselves, but on no account allowed to worry the others and teach them by example that habit almost characteristic of the English horse, viz., kicking.

Foals should be turned out to pasture, but it must be sufficiently long to afford a bite and so prevent close grazing which is a cause of parasitic invasion. Wet pastures are fruitful sources of parasitism, and they also contribute to the feet becoming flat and spreading, for these reasons, and the fact that the herbage is frequently poor in quality, they should be avoided.

Confinement in a straw-yard is no place for a growing animal, the utmost freedom should be given; so long as the pasture affords sufficient grazing, the rougher it is underfoot the better, it teaches him to pick his feet up and look at the ground he is travelling over. A moderately hilly pasture is an excellent place, especially for the foal that will eventually become a saddle horse; it teaches him



to be handy, and lays the foundation of that invaluable faculty of having a 'spare leg.'

The whole of the horse's future usefulness and handiness should be acquired at this time of life, and not when he has to carry a man. He should be taught if intended as a saddle horse to take a pleasure in jumping, small obstacles only being used, in fact so low that in the first instance all he has to do is to walk over them; ditches, banks and other obstacles should be gradually introduced, and if he avoids these he should be caught up and led over by hand. In all such cases every encouragement should be given to overcome such natural fear as may exist.

The man who rears a single foal may smile at this system, but he can, where possible, successfully imitate it by allowing the foal to accompany the mare at work, by which it gets used to sights and sounds, is taught to educate its limbs, gets handled and petted, and receives daily instruction of the utmost value when the time arrives for surrendering its liberty. There is not the slightest reason why the foal should not accompany its dam either to the plough or to market, or the ordinary carting work of the farm, and with very little management they are capable of travelling considerable distances.

In course of time it will be necessary to separate the fillies from the colts, and the period for the castration of the latter must depend upon their state of development. The forehead and neck are always backward in development; the back and hind-quarters often appear to belong to another animal, and the existing state of development and time of the year must decide the question. Twelve months of age is a suitable period of life with most animals, and the spring of the year better for the operation than the summer. Many animals will be improved by delaying the operation for another six or even twelve months.

*Breaking.*—When the final stage in its young life is reached, viz., that of so-called 'breaking,' there is only one man who can do it, and that is he who never loses his temper with a horse. Harshness and severity of any kind

defeat the object in view; firmness and kindness, with good hands and a good seat, are the four qualities most difficult to find in combination, but are the secrets of success.

If as foals, yearlings, or two-year-olds the young animals have been used to be haltered, handled, taught to lead and turn, tied up, feet lifted, wisped, and petted, the remainder of the work is simplicity, for they are already two-thirds broken.

When temper is shown by them it is no use meeting it with temper, but it may be met by restraint; the animal must be shown how powerless he can be rendered, but without violence of any kind. Lessons of restraint may require more than one administration, but they are effective, and the time comes when unconditional surrender is made and no further resistance offered, provided he has been treated kindly though firmly throughout.

The contrary renders him suspicious, shy, and timid, there is an utter want of confidence shown by him in everything; he is always on the look-out for trouble, and if so constituted he becomes vicious. It is well to remember that vice is more frequently the result of injudicious training than the fault of the horse.

The late Captain Hayes did excellent work in popularising rational methods of horse education. We shall have both in this, and the chapter devoted to military hygiene, to refer to the training of horses for saddle and draught, and shall aim at inculcating the modern to the exclusion of the seventeenth and eighteenth century systems.

Both a horse's manners and paces are undoubtedly improved by judicious training, yet there is a limit beyond which improvement cannot go. A naturally clumsy mover may be improved, but can never be made into a sharp, active horse. A naturally clever horse may be made into a brilliant hunter. If a horse cannot jump naturally, no amount of training can make him 'clever'; if he is a clumsy, unsafe mover with low action, and built on bad lines, the trainer may effect some improvement by various

devices; but such lessons are forgotten, partly or completely, when he leaves his hands.

Elsewhere we shall go more fully into the principles which should be aimed at in training a horse for saddle work, and shall urge simple straightforward methods, with as little turning and wrenching of the limbs as possible; the ordinary saddle horse does not require the same training as that artificial product the polo pony, nor does he need the accomplishments of the circus.

In these principles of training it is assumed the horseman rides with his legs, and does not hold on by his hands, and is thus able to give the animal the necessary freedom of head and neck. It is no longer considered needful to 'raise the forehand' by means of a severe bit and a dead pull on the mouth.

#### THE HORSE IN THE STABLE.

*Clothing and Clipping.*—When young animals are brought for the first time into a stable, or older horses taken up from grass, the greatest care should be taken with regard to the ventilation. Everything, doors and windows, should be left open, or for a certainty the animal will contract a catarrh. No clothing of any kind should be employed, though as the dirt and hair are removed from the body by grooming a light sheet may be used to take their place, and gradually the full clothing brought into use depending on the time of year.

As a matter of fact, excepting in the winter and only then after the removal of the coat, no clothing need be used. We fully recognise that this advice will not be followed, as one of the great points secured by clothing is a fine glossy coat, while a certain amount of body soiling is also prevented. No unclothed animal in winter can possibly carry a fine glossy coat; no animal in summer unless clothed ever carries quite such a clean coat.

The question of clothing, clipping, and the nature of the animal's work are intimately associated.

A hunter must have his winter coat removed, and consequently must have clothing to take its place. The horse at slow draught work neither requires the coat removing nor clothing, not even in the coldest winter; the troop horse if lying idle all the winter should be unclipped and un-rugged, if worked during these months he must be prepared for it by clipping and the coat artificially replaced.

Animals performing fast or severe work with a long coat, suffer an unnecessary drain on the system; the sweat of the horse is not a simple mixture of water and salts, but of water, proteid, and salts, and the observed loss of flesh which followed horses being worked unclipped, as was frequently the practice a generation ago, is thus readily explained.

The chance of chill following the return to the stable of an unclipped animal, with a long wet winter coat that takes two men an hour to dry, has not been exaggerated. The chances of chill would be still greater but for the presence of the above-mentioned proteid and the extraordinary amount of saline matter in the sweat.

We must clearly distinguish between the necessities of a business stable, and the requirements of the stable containing horses of pleasure.

In the former summer clothing is out of the question, a rough blanket, wool lined, preferably with a crupper to insure it being kept in its place, and a buckled breast piece is all that is required. The fastening should either be secured to the blanket or the ordinary roller applied. With the former care must be observed that the stitching does not injure the back, or that it is not pulled up so tightly that the piece of webbing comes down on the spine and inflicts injury.

There is nothing to beat a well padded roller, but few rollers are well padded, and even when so in the new state, through use they rapidly flatten and the entire pressure comes on the spine. Sore backs from either of these causes are common, while the remedy in either case is obvious.

A horse in poor condition is far more likely to be injured by a roller or blanket fastening than one with plenty of muscle on the back.

Preventive measures consist in taking the pressure off the spine by placing something under the pad of the roller, and as a temporary measure this may be a hay wisp or a horse rubber. In cases where the roller is stitched to the blanket and injury results from a horse being poor in condition, the best remedy is to cut through the webbing over the spine so as to insure no more damage is done, and place under the blanket where the webbing exists a handful of straw or hay on either side of the spine so as to take the pressure off entirely.

With horses kept for pleasure the clothing should be wool, but not heavy, three rugs on a horse during winter are too many. The largest amount of hair we obtained from a heavy horse weighed from seven to eight pounds with the dirt it contained; with a well bred animal it would be considerably less.

Two blankets, each about 8 lbs. in weight, are ample in the depth of winter.

As to the use of a hood, this seems to be largely influenced by fashion; it is rather like wearing a nightcap in the house and then going out of doors with nothing on the head. Hoods should only be seen in the Hospital. They require careful fitting to keep the opening for the eyes in the right place, but even then a hood is very liable to shift, and a head collar placed over it does not always succeed in keeping it in its place.

The bottom of the hood should fasten tightly to the blanket, so as to prevent it running towards the ears when the horse's head is depressed, as in feeding off the ground.

All clothing should be shaken daily and aired. The grease on the inside of the blanket may require brushing out.

Clipping is a comparatively modern stable procedure of inestimable benefit, and now rendered simple and time

saving by means of mechanical appliances, by which several horses can be clipped in a day. It is a process which should not be done too early until the winter coat has 'set,' or it is considered to spoil the next season's coat. Under ordinary circumstances a horse requires clipping twice during the winter.

Experience appears to dictate the advantage in riding horses of a patch left unclipped under the saddle, while opinion seems pretty generally in favour of leaving the hair on the legs of hunters, on the supposition that such legs are less likely to be injured by thorns. This explanation is difficult to understand, hair certainly does not keep out thorns; nor do we think it keeps off, but rather encourages, the skin eruptions on the legs that town horses suffer from in the winter, and to prevent which the hair is left long on the legs.

We see no reason why hair should be left on the limbs, but would keep it as short as on the general surface of the body; such legs are readily dried when the animal returns from work, an impossible thing to do with long hair. It is quite likely that the idea of the hair being a protection arose from the fact that the practically hairless skin of the heel is so liable to cracks and fissures during cold weather, or when left wet; but this skin is quite different to the general skin of the body, in the same way that the skin of the hand, which is so liable to crack in winter, is quite different from that of the face which practically never cracks.

Fashion dictates the hair should be left on the legs; and the same custom insists on its length being a valued characteristic of the cart horse!

*Care of the Legs.*—Bandaging the legs after work, especially in the winter, is a valued method of preventing skin eruptions, especially that known as 'mud fever.'

With long hair it is impossible to dry the legs; if they are bandaged while wet no harm results, as the bandages keep out the wind, and it is the wind acting on the wet skin which produces the trouble.

Apart from wet or muddy weather, the value of bandaging

as a support after work is undoubted, it prevents legs from filling by supporting the lymphatic vessels; so that after a hard day's work instead of the animal coming out with 'filled' legs the latter remain 'fine.'

Mud fever alluded to above was originally believed to be due to some irritating property in the mud, but this is known to be incorrect. Mud fever is due to washing the legs and not drying them, and in industrial stables practice shows that this class of affection is prevented by not washing the mud off, but letting it dry on and having it brushed out. The explanation is simple, the coating of mud excludes the air and prevents the temperature of the skin from being lowered.

In connection with chapped legs (mud fever) and cracked heels, it is to be observed that some legs are more liable to the latter condition than others; white legs, for example, especially with a pink skin devoid of pigment. It is not, however, because the legs are white that the heels crack, but for the reason that it is only a white leg that gets regularly washed.

If legs are washed they must have all the soap taken out of them and thoroughly dried, a long operation that only a first-class groom will do conscientiously; after drying the legs are hand-rubbed and then bandaged.

The only way to thoroughly dry the skin of the heel is by means of a soft rubber, and when all the wet is got rid of, to dry the part with bran which is rubbed in until it falls off the skin, showing no moisture remains.

It is usual to attribute both mud fever and cracked heels to bad stable management, and this is undoubtedly true. Both can be prevented by the greatest care and attention.

*Grooming* is required as a matter of comfort and convenience to the owner, and as a necessity for working horses. For the horse in training it is something more than mere body cleanliness that is aimed at, nothing can be better for muscles than massage, especially for hard-worked animals, and every good groom who puts heart into his work imparts this as well as cleanliness.

An animal left ungroomed or turned out in the rough, collects in the coat the shed epithelium, the salts of the sweat and other dirt collected from without. This condition of skin can be readily ascertained by rubbing the coat up the wrong way, a fine grey powder escaping which rests on the surface of the hair. Such a condition of skin is believed to produce both mange and lice, and though both, especially the latter, may be found in animals not groomed, it is not the absence of grooming which produces it, but exposure to infection, which with the condition of skin finds a suitable soil and the disease gets a hold.

We certainly do not know where both these parasites are obtained from, but there is reason to believe they may lead a saprophytic existence apart from the body, probably in the soil, and become parasitic on gaining the skin. Whether this is the case or no it is certain that animals kept clean in their bodies do not suffer from either, and that both affections are associated with neglect.

Mange is one of the scourges of armies in the field, and though the absence of grooming no doubt contributes to the life of the parasite, it cannot produce it.

Working horses living in the open require very little grooming, on this point there is a consensus of opinion and its explanation is simple; the removal of the whole of the shed epithelium exposes the body to a certain amount of cold, but the effect of grooming is more particularly to remove the actual fat which so largely exists in dandruff. This fat is protective, it prevents to an extent the penetration of rain, and assists in preventing loss of heat.

All that horses require in the open is one grooming a day to remove the actual dirt from the coat, but not to so freely stimulate the skin as to cause it to produce epithelium at too great a rate. The body brush should be lightly applied, and the grooming finished with a 'wisp'; both mane and tail, however, require thorough cleaning, not that either of the skin affections mentioned begin there, but for the comfort of the animal.

Animals in regular work living in the open, are nothing



like so dirty as the idle horse living in the open; the skin acts at work which is the explanation of the difference.

Animals, particularly mules, may be kept wonderfully clean by giving them merely a sand-bed to roll on after they have come in from work. Horses get as fond of this as mules, and go instinctively to the sand-bed on returning from work. It is their natural way of 'dressing' themselves, while sand, though it may make the coat harsh, certainly cleans the skin.

The grooming of horses living in stables is quite another operation; it is, or should be, thorough. It can hardly be carried to excess, for there is clothing available to take the place of the removed epithelium and fat, while the exercise of friction to the body causes the fat already in the skin to give that gloss to the coat which is so much admired in a stabled animal. Such horses are no doubt more liable to chill on exposure, though it is difficult to say how much of this may be due to the removal of clothing and how much to the removal of dandruff.

To thoroughly groom a horse is hard work; to give the animal the full benefit of grooming the work should be done with vigour, long strokes of the arm across and with the hair, and at the same time pressure. The weight of the body must be put into the brush, by which means the capillaries in the skin are stimulated, and the full effects of massage to the muscles obtained.

In those countries where massage is understood, as in the East, special leather pads are used on the hands, and brought down alternately on the muscles with some considerable force. Horses enjoy it, while the effect on their muscles is admirable.

There is a great deal of difference between the thorough grooming of the racing stable and the brush over that the majority of horses get, and the chief reason of this we have explained, it is simply part of their preparation and training.

The best time to groom a horse is in the morning; the grooming of a tired horse is never attempted by those who

know. All that an animal requires on return from work is to be dried if the surface of the body is wet, clothed, and made comfortable.

Drying a wet horse with a long coat is hard work, it requires two men to do it properly. The ordinary means of rubbing down is clean straw, the straw does not dry the hair by absorbing moisture, but by friction. The friction should be thorough, it is good for tired muscles (in fact, nothing can take the place of rubbing and kneading tired muscles), and at the same time reduces the chance of chill.

It is difficult to say when the body of a horse is permanently dry after sweating, owing to the curious physiological phenomenon of 'breaking out' into a sweat, a second or third time after being previously dried.

The careful horse-keeper looks out for this peculiarity, which is much more marked in some horses than others. It can only be met by a fresh process of drying, and may to an extent be controlled by not watering too soon. On this point we wish to be very clear, let the horse in a state of sweat get its fill of water on return from work, before the saddle is removed or anything done. Let him drink his fill, and be certain he has it; this will make him sweat more, but it cannot be helped. If the weather is favourable he should be walked about until nearly dry, then finished off as above described, and no more water given if he is liable to recurrent sweats; if not so liable he can be again tried before being fed.

The sponging out of eyes, nostrils, and dock, in the order named, is a hygienic advantage, but it requires a lighter hand for the nostrils than is usually applied. The sponge does not need to be squeezed up into the nasal cavity as if a hole were being cleared out, nor should it be picked up directly off the ground and adherent particles of sand and straw thus introduced. These cut the Schneiderian membrane, and streaks of blood are frequently seen after such an application; in consequence there are few minor things a horse resents more than his nostrils being cleaned.

A common sponge, which frequently contains shells, should never be employed for stable purposes; they leave their permanent mark in the nostrils from the injury they are capable of causing in rough hands.

Pulling the ears, as it is termed, of an exhausted horse appears to refresh him, and he always seems to enjoy the process.

We have made no mention of the care of the feet in the stable as a separate section is devoted to the hygiene of the foot.

*Washing Horses.*—Horses are sometimes washed, particularly is this so when they are covered with mud, as in the case of grey horses or when they become discoloured. Washing is a harmful practice and never adopted by a good groom. A man lazy enough to wash a horse will never have the energy to dry him, and drying is a long and tedious process which requires assistance.

Mud should be left on the body, as on the legs, until it is dry, when it can be removed by means of a dandy brush followed by the ordinary grooming.

*Securing Horses in the Stable.*—On p. 302 will be found a very full account of the proper way to tie up horses either in a box or stall, but there are still some points to be considered in connection with this matter.

The head collar should fit well, the brow band must be long enough for the head, and the nose band sufficiently large to enable the animal to freely open its mouth. The head collar should not be drawn up too high or injury to the zygoma from the nose band results; further, the higher it is drawn up the tighter it becomes, and the less room there is for the horse to move its jaws. The throat strap must never be tight but easily admit the breadth of three fingers.

Small as all these points seem, they constitute important matters in the care of horses, especially among large bodies of horses where individual attention is so difficult to procure. A well fitting head collar is a matter of importance and of comfort.

Some horses acquire the knack of removing their head collars, or 'slipping' them as it is termed, and they take great care to be very seldom seen at the operation, which is performed with remarkable rapidity. Even if one secretes himself in a stable for the purpose of seeing a horse well known to possess this accomplishment remove his head collar, it is quite likely disappointment may follow. Hayes\* has witnessed it, and describes that the horse gets his head rope on to the top of his poll and then hangs back; the rope is prevented from slipping off the poll by getting held behind the buckle of the check piece. In our experience the horse slips his head collar by putting his head under the manger, and catching the poll piece on the edge of the manger, and by gently hanging back pulls it off his head.

Once this trick is learned no ordinary head collar can be kept on; tightening the throat lash is of no use and often harmful, for it cannot prevent the poll piece being pulled forward, though it may make the head collar too small to slip over the eyes, where it gets fixed and causes injury.

One or two contrivances may be adopted; for instance, a neck strap may be worn, and the head rope attached direct to it; or a special throat strap may be made to the ordinary head collar, quite distinct from the head collar itself, but attached to it by an elongation of the brow band.

A head collar with a separate throat strap cannot be pulled over the head, and prevents this dangerous habit.

The length of a head rope or collar chain is a matter of supreme moment. It is fully dealt with on p. 302, and the object of this precaution explained. On no account, however, should head ropes or collar chains be made so short that the horse cannot lie down comfortably, as we shall presently describe a horse does not sleep on his breast but must lie out quite flat with his head on the ground, and he cannot assume this attitude with a short fastening.

Some animals require a double fastening, one from either side of the manger, probably all would be the

\* 'Stable Management and Exercise,' Captain Hayes, F.R.C.V.S.

better for this method, but it is especially desirable in stables with bails, so as to keep each animal as far as possible on his own ground, and prevent him encroaching, especially when lying down, on that of his neighbour.

Various methods of fastening are dealt with at p. 303, the point to which we here draw particular attention is the absolute necessity for a counterpoise at the end of the rope, either in the form of a metal or wooden block, so that the head rope is never slack. The weight of the counterpoise should equal the weight of the rope or chain, otherwise it will not act at all positions of the fastening, and especially at that position which is full of danger, viz., when the animal has been standing at the full length of the fastening and advances to the manger. If the counterpoise is not sufficiently heavy, the slack of the fastening is left as a loop into which he can easily introduce a hind foot, as in the act of scratching an ear, with the most disastrous consequences.

Where boxes are available, no fastening is required excepting during the time the animal is being dressed and the box cleaned out.

*Bedding.*—A good bed for a hard working horse is probably equal to an extra feed. It is a matter of the utmost importance that horses should be induced to lie down, not only in order to rest their tired muscles, but to get the weight of the body off their feet. No bed equals that of straw for warmth and comfort, but economical considerations have largely brought 'peat moss' into use as a bedding, while as an additional advantage it is found to be very absorbent, so that stable drains need not exist.

Where straw is used that of wheat is preferred to all other; oat straw is frequently used but is more liable to be eaten. Neither barley nor rye straw are liked in the stable, they do not make as good a bed; barley straw is soft and wanting in durability, while rye is very hard and wiry; rye straw has another market outside the stable, being largely used in brick making, packing bottles, thatching, and stuffing collars.

Grooms are always wasteful, but with bedding they are exceptionally improvident; most manure pits contain good bedding, which probably only requires drying or exposure, or not even this. In the army one of the best tests of the good stable management of a regiment is the condition of the manure pit.

A good bed in a stall can be maintained for horses where economy is practised by the allowance at the rate of a truss of straw per head every fourth day. In high-class stables, allowing for the usual waste, the same amount every two days will be required.

Bedding should be removed from the stable daily and placed outside, litter sheds being provided for wet weather. The practice of turning it up under the manger for the day is a lazy and dirty practice. It should be placed outside and aired if only for an hour or two. During this time it should be frequently shaken with a fork, and to get the full effect of airing should not be placed in a heap but in a layer not more than six inches in thickness.

Bedding left too long in a hot sun breaks up easily, but it is seldom in these islands that this damage has to be guarded against.

Where economical 'bedding down' is practised, the new and old bedding after drying should be mixed; where horses have the habit of eating their bedding, the old material should be used for the front of the stall and the new placed behind.

The making of a bed is not as simple a matter as it looks; it is a stable accomplishment only learned by practice and experience. The bedding should be higher at the sides than in the centre, so as to bring the largest amount of straw under the body.

The majority of horses prefer standing on bedding to the bare floor; they will go out of their way to get their feet, especially the hind feet, on to bedding; conversely many will not tolerate bedding under the fore feet, and persistently rake it away until the feet come on the floor.

This is a very annoying habit to the groom when the

bedding has been 'set fair,' and may lead to a breach of the peace; but chastisement is not of the slightest use to prevent the habit. In some cases it may be due to the ends of the straw tickling the legs, if so bandages might be tried.

Peat moss as a bedding is very largely used, it has economy to recommend it and the further advantage of absorbing the urine. A clean bed of moss litter though not attractive is comfortable, and horses do admirably upon it. A neglected bed of moss is an unpleasant sight to look upon, a black squelching mass trodden down to the consistence of clay, and about as comfortable and warm to lie on. The disadvantage of using peat moss as bedding is the common impression that it requires no care, whereas it requires more than an ordinary straw bed. It is not self cleansing, every day it remains down adds to its foulness unless all wet portions are removed daily. Six pounds of the litter should be allowed daily for a stall to replace that which is soiled.

Good as moss litter is where proper hygienic care is practised, it is capable of committing great havoc to the feet where it is used under the impression that it requires no care or looking after. The feet are bathed in a poultice of ammonia, and the action of this on the horn of the sole and foot pad has only to be seen to be realized.

Peat moss bedding badly kept does not only provide a wet uncomfortable bed for the horse to lie on, but destroys the feet. No objections of a stronger character could possibly be put forward. Under good hygienic management it provides a comfortable, elastic dry bed, does no damage to the feet, saves the stable drainage, in fact drains need not exist.

Sawdust makes an admirable bed, if it can be obtained in sufficient quantity: sand makes a soft but cold bed, but there are times when it may be usefully employed, viz. when nothing else is obtainable. Sawdust, and to an extent sand, like peat forms an absorbent bedding, which requires all solid portions to be removed daily if it is to be kept in a hygienic condition.

The removal of fæces from the stable is done by hand; the smaller the amount which passes into the drains the better. The watchful groom during the day is always on the look out for evacuations, as the sooner they are moved the cleaner the bedding and feet are kept. It will be observed how frequently horses stand in their recently-dropped evacuations, this cannot be purely accidental, and we think the reason is owing to the warmth imparted to the feet.

Some horses contract a habit of eating their own fæces; we have never succeeded in inducing them to eat those of another horse, but their own they recognise at once. This disgusting habit is difficult to explain; some believe it is due to deficiency of salt in the food, and extra salt may be given as a preventive, but we have never known it effect a cure. The animal becomes extraordinarily cunning in depositing his excrement in such a position, as to enable him to reach it with facility.

When bedding is neglected and dung allowed to collect in the feet, the foot pad frequently takes on an unhealthy action with a discharge from the cleft, followed by a destruction of the surface and cleft of the pad. This disease known as 'thrush' is an indication of bad stable management; it will be alluded to again in speaking of the hygiene of the foot.

*Injuries caused by lying down.*—As a rule we think it will be found that most horses prefer one particular side to lie on, and the choice is probably more frequently the off than the near.

Horses do not sleep for long at a time, they are generally up and down several times during the night, and in the matter of disarranging their bedding they closely resemble the biped. Some hardly disturb it, the bed in the morning is found much as it was left overnight; others have half their bedding away from under them, generally in the passage behind. This is not without hygienic interest, the horse that gets its bedding out in the passage mainly lies on the floor, and an animal that lies on the bare floor may get injured.



Apart from throwing the bedding about, there are horses naturally clumsy when lying down, that work through or displace their bedding at prominent points like the hip, but particularly the elbow point and outside of the hock.

Whenever the elbow point or outside of the hock come on the ground (and these parts rest on the ground when the animal is seated on his breast), injury may occur to them, especially the elbow. The disease known as capped elbow is always produced in this way and in no other. No long-heeled shoe ever gave a horse a capped elbow, in spite of what has been taught for years in this connection; if it were capable of doing so not a heavy horse in the North of England or Scotland could escape.

If the attitude of a horse is studied when he is sitting on his breast, it will be seen that the foot which is supposed to cause a capped elbow is not even near the elbow but is placed under the breast.

A capped elbow is always caused by the point of the elbow coming in contact with the ground, and in no other way is the injury possible; it is an injury due to want of bedding, and this may be caused by carelessness of the attendant, or the fault of the horse. Animals which work through their bedding at night, which we have described above as 'clumsy' horses, are the most liable to this accident.

The above class of horse is best bedded on sawdust or moss litter, with straw on top. Bedding arranged like this is much less liable to be shifted.

Though capped hocks are caused by kicking, yet once an enlargement occurs on the point of the hock it is bruised every time the horse lies down. Again, if notice be taken of the attitude assumed by an animal lying down, it will be seen that the whole of the outside of the leg from the point of the hock to the foot is in contact with the ground. If the hock has been 'capped,' not only does lying down aggravate it, but it absolutely prevents all hope of permanent reduction.

The bedding for a capped hock case is the same as that for a capped elbow; in both the horse should be made to lie down on the opposite side of the body. This is accomplished by using two head ropes, one from each end of the manger, and so arranged that one rope is much shorter than the other. The horse is compelled to lie on that side where the head rope is the shortest; if, for example, the off elbow is capped, he should lie on the near side, to effect this the left head rope should be shorter than the right. Sometimes special pads are required to keep the elbow off the ground. They should be large, circular, and fix around the coronet.

An injury outside the hock in the hollow between the calcis and tibia is also caused by lying on the bare ground, and its prevention is a question of sufficient bedding. Whenever horses are seen marked on the outside of the hocks, it is certain the bedding is insufficient.

*Horses that never lie down.*—There are some horses that never lie down, and such cases are not uncommon among the heavier breeds. It is usual to associate these with ankylosis of the spine, and that the animal fails to lie down as he is conscious of the difficulty experienced in rising.

It is obvious that such horses do not get rested, and a good night's rest is one of the essentials for working horses. Mechanisms exist in the limbs which enable horses to sleep in the erect position, but it was not intended these should be always employed. It is not uncommon to find that a horse which never lies down, may drop during his sleep and is found in the morning unable to rise without assistance. Further, in his struggles to rise he may injure himself severely, perhaps fatally, as the spine not uncommonly fractures through or near the ankylosed portion. Such a fracture may occur not only as the result of struggling, but at the moment the animal falls, for we have known an ankylosed spine fracture at the moment a horse was destroyed.

As a measure of precaution, and in order to afford such

cases the needful rest, it is essential that horses so affected should be placed in slings every night, by which means they may work for years.

*Ventilation.*—The ventilation of the stable should not be under the control of the groom, but be regulated by the intelligence of the owner. A thermometer should form part of the equipment of every stable, and one should also exist in a protected part of the yard. A comparison between the two should be made twice a day. The greater the difference in the temperature of the two places, the greater the air impurity in stables which are naturally ventilated (p. 64). To maintain a stable at 60° F. throughout the winter, where only natural ventilation is employed, means that the air of the building has to be heated by the hot expired air from the lungs, which is an insanitary proceeding. Horses are never so healthy in winter as when living in an atmosphere only a degree or two above the temperature of the outside air; this difference should never exceed ten degrees, preferably five, and far better two. In practice it is frequently twenty-five or thirty degrees higher, and nearly all of this is produced by heated expired air. For the practical application of ventilation, see p. 62; the main point to insist on here is that draught is harmful, a cold stream of air is dangerous; in practice it would be far safer and better for the animal to live in an open yard with a free current of air all round, than to have a draught blowing on him for hours.

*Watering and Feeding.*—The hours of watering and feeding should be regularly maintained, feeding should be at least four times a day, and watering as often in the summer, and three times daily in winter.

Regularity in watering and feeding are points of the greatest hygienic importance, and the work of the animals should be so regulated that as little interference occurs to this as possible. Long hours of fasting should be avoided, it is a common cause of colic. We do not attempt to lay down the exact hours of feeding as so much depends upon the class of horse and the work performed, but a morning,

noon, afternoon and night feed are desirable for all horses, though they frequently only receive three.

With regard to watering, the rule is to water before feeding and to water four times a day if possible. At early morning, especially in the winter, little or no water is drunk, the mid-day and evening water are the chief sources of supply, while the late watering ensures the animal will suffer no discomfort during the night, especially during the summer.

A lazy groom will fight against the night watering and feeding, but it should be insisted upon in all establishments where sufficient labour is provided.

The principles of feeding have already been fully dealt with (p. 139). There is, however, one question connected with the management of horses which may here be suitably considered.

When numbers of horses are in bad condition in spite of a liberal allowance of food, and the work not being excessive, it is safe to say there is something wrong with the management. If the food is found to be good and wholesome, then it may generally be accepted as true that peculation is occurring, and that the horses are poor because they are being robbed.

In examining into the question, the whole system of stable management should be dissected; nothing must be taken for granted; everything must be seen. Even, if necessary, the weights must be verified. It is quite unnecessary to see or deal with more than the one or more responsible persons. No questions should be asked of the subordinate staff. The man or men responsible for the receipt and issue of the forage and the feeding should know everything, and if they do not, or are unable to give a perfectly clear and intelligent account of the system pursued, then there is something which needs explanation.

These inquiries are of a delicate nature, and must be conducted tactfully. If theft is going on, there is more than one person concerned. The examiner should express no opinion at such a time; silence is especially golden, and he

should learn more with his eyes than he hears with his ears, and not a point in the management or arrangement of the establishment should escape his attention and observation.

Though the strongest opinion regarding the cause of the loss of condition may be held, yet it is wise to examine every channel through which condition may be affected. For instance, the drinking-water, its quality, and the periods of watering, should not be neglected in the inquiry ; but in by far the majority of cases it is a question of food, and that only.

When a loss of condition is confined to individual horses it is probably a case of defective teeth, internal parasites, or other pathological conditions. There are a certain number of horses, like men, that no food will fatten, but there are relatively fewer horses than men so affected. Three per cent. at the outside, probably less, represents the thin members of the ordinary equine population that no food or care can improve in condition.

The question of water is fully dealt with in Chapter I., the only point left to deal with here is the senseless notion possessed by some grooms of the necessity for stinting their horses in water. Every horse should at properly appointed times be allowed to drink his fill, and if water can be kept always by him so much the better.

Some horses drink better from a trough, others from a bucket. A shy or nervous horse should be given ample time to drink, and with all the greatest patience should be exercised until they have drunk their fill. The raising of the head from the trough or bucket is often the signal for removing a horse or taking away the water ; as a matter of fact the horse only raises his head to breathe, as during the time he is drinking no air can enter the lungs. Ample time for watering should be insisted upon, and in large establishments it should be carried out under competent supervision.

There is not the slightest objection to a horse drinking when hot, though occasionally in winter it may be desirable to take the chill off the water.

The question of the amount of exercise a horse should receive will be dealt with later.

There are certain *Stable Vices* which must now engage attention, they are Windsucking and Crib-biting, Weaving, and Kicking.

*Windsucking and Crib-biting* may conveniently be considered together as they are frequently complementary; though a horse may be a windsucker without being a crib-biter, he cannot be a crib-biter without being a windsucker. It is quite likely in many cases that crib-biting is learned before windsucking; the animal during the time it is being dressed frequently lays hold of the manger from ticklishness, and it is conceivable that this may in some cases be the forerunner of crib-biting. Other horses learn it by imitation, and it is said the lesson may be imparted in a few minutes, which in our opinion gives the horse credit for more observation and powers of imitation than we are inclined to believe.

In whatever way the vice is acquired, there is only one thing of which we can be positively certain; that it is contracted as the result of idleness. Hard-worked horses seldom crib-bite. It may also prove to be hereditary; common among British horses, it is unknown among those of S. Africa.

The question of whether air is sucked in or expelled is one that can only be settled by experiment, and then is only of academic interest. We believe there is no doubt air is sucked in, though the position assumed is suggestive of something being expelled.

Nothing can cure these vices. Mangers may be taken away, and the horse fed from a nose bag, or off the ground, but it is not defeated; it soon learns to windsuck without crib-biting. Straps around the neck are useful in a few cases, but no horse ever forgets the vice. That pleasure is derived from the vice is evident from the fact that the punishment of a neck strap with an iron gullet plate is no deterrent, while perhaps better evidence is afforded by the incisor teeth which may be worn down so

as to expose the pulp cavity, and yet it does not stop the vice.

Muzzles, perforated mouthpieces, and many other contrivances have been employed, all may be of temporary use, but an owner may be quite certain he will never cure the vice, though the above methods may help to control it.

Crib-biting leads to alteration in the incisor teeth, while windsucking induces a condition of debility which in some cases is extreme, and further causes changes to occur in the stomach which are frequently associated with colic. In a few rare cases we have known a windsucker to be unaffected in his condition by this vice.

A crib-biter may be kept on pillar reins, fed from a nose bag, or off the ground, wear a crib-biting or ordinary muzzle, a 'cribbing' strap with a piece of iron in the gullet piece, which inflicts punishment, or a hollow bit in the mouth to prevent air being swallowed, but none of these contrivances can cure the vice, some may temporarily prevent it, but they are never satisfactory. The best advice to give the owner is to get rid of the horse, and in the meantime keep it isolated should any other horses be in the stable.

*Weaving* is a curious vice associated with a highly nervous disposition, and in some cases due, in our opinion, to mental aberration, in others to idleness. A horse might learn to weave by playing with his collar chain, as some do by pulling it to and fro through the manger plate, but as a rule it is a nervous, irritably constituted horse that weaves, and like windsucking it may be hereditary. A weaver does not give himself sufficient rest, the gymnastic display is always more evident when he is being watched, so that such a horse should not only be placed in a box, but ought never to be the object of curiosity. We do not think the vice is ever forgotten.

*Kicking* may be vice or play, both are most destructive of stables, sources of lameness, and a danger to other horses and men.

Kicking as a vice is more frequent with mares, and may

be dependent on the generative functions, for it is always more pronounced at the period of œstrum. It may be due to bad bringing up, horses being annoyed when young, such as being 'flicked' with a rubber every time the man passes, until flicking and kicking become associated in the mind of the horse.

Horses may kick from disagreement among themselves. Whatever means they have of communication with each other are entirely unknown to us, but they certainly exist, because without some means of communication it would be impossible for two animals to quarrel. It is perfectly true that each watches the other very closely, attitude and expression speak volumes and are instantaneously recognised, but apart from these, we believe there may be other means of communication, and if they exist the spread of panics is accounted for.

There are sour-tempered, ill-conditioned horses that seldom agree with any others, and that invariably kick a stranger. In the management of a stud of horses it is important that animals should occupy the same position in the stable and know their companions, by which means kicking is controlled.

Some horses will kick when feeding and at no other time; the majority of stable kicks met with probably occur during feeding; the encroachment of a neighbour at this time is not appreciated. Rack chains should be used during feeding to prevent a horse trying to get at its neighbour's food. Obviously these are only required when stall partitions do not exist.

Kicking from sheer idleness and lightness of heart is very frequent. It generally occurs at night, is started by one animal and kept up by his neighbour, especially if a stall partition exists. By the morning this may be converted into matchwood. In such cases the sound of kicking produced on the board acts as a stimulus and encouragement. Not only in order to save the stall partition, but also to control the stimulus, kicking mats seen in Fig. 89 should be employed.



The prevention of kicking implies a profound knowledge of stable management. Horses may kick at one time and not at another, at a strange companion, during sexual excitement, from fright, from being interfered with during feeding, and many other causes. The cause has to be known before effectual preventive measures can be applied; the prevention is far more important in stables with bales than in those with stall partitions.

Horses that fail to agree must be kept apart, horses that know and like each other must be kept together. This sounds a mere platitude, and yet is so insufficiently observed that special attention is here drawn to it.

Well-known kickers must be placed by themselves, and every contrivance adopted to control the habit. Some will kick a partition down though no other horse is near to excite them. Such are accomplished kickers and should wear a kicking block or other contrivances to be presently mentioned.

A kicking log is a piece of wood at the end of a few links of chain, and worn by means of a padded strap above the hock. It may also be worn around the pastern, in which case the wooden log lies on the ground when the leg is at rest, and there is no strain on the strap. Sometimes no log is employed, nothing but a few links of chain attached to a strap.

The theory of this log is that when the horse kicks it hits him on the leg, but we doubt whether this is the real explanation, and consider that in many cases the influence is a moral one; something is hung on the leg which the horse knows has no right to be there, and its mere presence prevents him from using the limb to kick with.

In many cases the kicking log or chain is no use, and something heavier has to be employed; in such cases—very rare ones—we have gone on increasing the weight attached to the pastern until the foot has become too heavy for the horse to lift with ease. For this purpose we have attached a drag shoe or any other weighty piece of iron to a strap around the pastern, arranging it that no weight is

suspended from the pastern until the foot is lifted off the ground. This will control a kicker, but it is very difficult to get a contrivance of this kind regularly applied.

The legs of an inveterate kicker may be hobbled together by light hobbles, which allow of limb movement but no kicking; but the use of these may prove dangerous excepting in capable hands.

Another contrivance is a block of wood hollowed out to the shape of the heel and pastern and placed in the latter, being secured by a strap around the pastern. The theory of its application is that the block of wood prevents the foot being flexed, and kicking without flexing the foot is impossible.

Kicking from high spirits and insufficient work is obviously very simply dealt with.

The damage done by horses to their companions and to themselves by kicking is very great. About ninety-eight per cent. of fractures are produced by kicks, the bones most frequently broken are the radius and tibia. In both cases the injury is inflicted on the inner aspect of the limb, and at that part where the bone is exposed and only covered by skin and periosteum.

The injury on the hind limb is about 27 inches above the ground, which tells us that in the case of baled stables the bale should never be of such a height as to admit of this blow being delivered beneath it. In the fore limb the kick is implanted on the inside of the arm about two feet above the ground; see also p. 311.

When a determined kicker makes an attack on the partition of box or stall, he often drives his shoe across the foot, the clip may penetrate the sole and damage be inflicted. More frequently the chief evidence of kicking is borne on the shank, which swells, becomes extremely tender, and frequently ends in an unsightly and thickened leg or capped hock, which tells its own story to the trained eye.

With an inveterate kicker no pain or suffering incurred through his own vice ever acts as a corrective in the

future; a big and painful leg which he can hardly put to the ground is forgotten when cured.

*Stable Injuries.*—Injuries produced in the stable from other causes than kicking must now occupy our attention. They may be divided into injuries due to defective construction, those due to carelessness and bad stable management, and those caused by conditions not wholly under control.

Injuries due to defective stable construction are nearly matters of history, so great has been the improvement in this respect in recent years.

Cervical abscess, or poll-evil, was common enough in stables with low doors; if a horse ever knocked his head going through a low door, he invariably threw up his head every time he passed through it again, and repeated bruising led to deep-seated and most serious trouble. If a horse has to be led through a low doorway or gangway, as on board a ship, the secret of preventing him from damaging his poll is to give him a perfectly loose head, and never to attempt to pull it down; he will lower it of his own accord, any attempt to pull on it means that he will throw it up.

Narrow doors have fractured many a pelvis and bruised many a hip; once a hip has been bruised by passing through a narrow door it is never forgotten; the next time in all probability the animal will charge the opening in order to escape as quickly as possible. This in fact becomes a habit with some horses, and a most dangerous one.

Overhead hay-racks lead to the introduction of foreign bodies in the eye, such as hay seeds, or even laceration of the cornea from projecting hay stems.

Saddle or harness brackets on the heel post have cost many a horse his eye, or severe injury to the face, through being fitted too low.

Torn eyelids and nostrils from nails in the stable wall or partitions are most frequent causes of injury. If there is a nail anywhere within reach a horse is sure to come in

contact with it; the nostril gets torn up, or the upper eyelid left hanging by a neck of skin, or even the eyeball destroyed.

In stables with bails bites on the neck are very frequent; in this way a horse may be disfigured all down one side of the neck. The obvious remedy is to remove the horse which inflicts the injury, who will be found to be a bully, and to have suffered no injury whatever from retaliation. Bites on the ear from the same cause are much more severe, as they cause permanent disfigurement; the cartilage curls up and a very unsightly appearance is presented.

A horse given to biting should be examined to see whether he is a 'rig'; complete castration certainly controls horses in the use of their teeth.

Injuries due to bails are generally caused by the animal kicking over them; if the bail is high he becomes a fixture, and in his struggles to get free removes the skin from the hock to the perineum. Bails have been very fully dealt with at p. 311, it is only necessary here to repeat that a bail should be fitted sufficiently low to prevent a horse getting kicked, and at that height should he get over it, very little difficulty is experienced by him in getting his leg back; whereas with a high bail if once over he is suspended behind, and cannot of his own efforts get back.

With deep bails horses sometimes get under, and with the bail on their back are unable to rise; the accident is not a serious one, though the horse may be damaged by his struggles, as he invariably does when he finds himself in difficulties.

'*Slipping up*' in the stable is a common cause of injury, especially when the animal is being turned around in the stall, the hind legs go from under him, and he falls heavily on his pelvis, which in consequence is frequently broken. All stable floors are slippery, but the use of sand is an obvious precaution which should always be adopted. Slipping up is frequently due to the carelessness of the groom causing the horse to turn too suddenly, by giving

him a 'flick' with a rubber. A narrow stall is a fertile cause, but even when ample room exists a slippery floor is by far the most common cause.

*Heel Galls* are caused by the hind leg being got over the head rope or chain; it has been fully dealt with elsewhere (p. 304), and no further reference to it is needed. It may lead to a most serious accident, as horses thus caught up are very liable to throw themselves down in their fright and fracture the pelvis.

A horse *Cast* in the box or stall is one that is unable to rise owing to its position. The position is invariable, viz., the animal has got so close to the wall that the forelegs are bent at the knee, and in such a position no horse can rise. The cause of casting is always due to rolling in either box or stall, so that within certain limits a narrow stall or small boxes induce this accident.

If the horse were to lie in the middle of an ordinary box he might roll from side to side with safety; but should he select some place away from the middle and then roll over, he may roll so close to the wall that the fore and hind legs at once double up, and such a horse is quite helpless to rise without assistance. An animal fond of rolling, or a clumsy roller, may be cast in a large box; in fact, as mentioned at p. 298, a large box affords no protection in this respect to some horses, for should they select to lie down near the wall and then roll over, they are as effectively cast as if in a box half the size.

Once the animal finds himself unable to rise, a terrific struggle ensues, during which he may press his hind quarters further away from the wall, which increases his difficulties, as it brings the head nearer to the wall, in which position he is quite unable to rise. The noise occasioned by this accident generally attracts attention, but until worn out by exhaustion, the animal continues to inflict injuries on its head, hip, shoulder, or other prominent parts of the body, and may look a very sorry object when got up.

There are two methods of releasing a cast horse from its

difficulties ; if in a box a rope can be placed on the fore and hind legs and the animal rolled over, when it rises at once. The other method, and the one which must be practised in a stall, is to pull the body back from the wall until the fore-legs can be extended, when the animal gets up without difficulty.

A horse may be cast in a field by rolling into a ditch ; he is as helpless on his back in a ditch as he is when cast in his box.

Old horses if cast are very liable to break the back.

*Stable Sprains.*—There is one class of injury which a horse is credited with inflicting on himself in the stable, and that is a sprain. Though we do not deny a sprain of the ligaments of the hip or stifle are possible, yet a sprain of the suspensory or flexor tendons caused in the stable is an utter impossibility, though invariably urged by those in charge of the horse. There is a reason for the excuse, very apparent to those whose duties have brought them in contact with the class of man entrusted with the care of horses, and who know the damage these horse guardians are capable of inflicting on the pockets of their masters when out at exercise and under no control. The question of sprains is fully dealt with at p. 769.

Injuries from *hanging back* in the stable when tied up are not uncommon. Hanging back is a habit acquired by shy and nervous horses, and might almost be regarded as a stable vice, so persistent is it when once established. If the head collar and collar shank do not break the horse almost invariably comes down on to the points of the hocks, and scrapes them raw on the ground. Once the trick of hanging back is acquired, the horse had better be kept in a box and never tied up.

*Diseases the Result of Bad Stable Management*—and this term is used in its most comprehensive sense—are numerous. Lymphangitis, its causes and prevention, are dealt with at p. 145. Colic and abdominal trouble is fully considered in the chapter on feeding. Catarrh and pneumonia, skin diseases, fractures, wounds, and contusions,

cracked heels, 'mud' fever, and thrush, have received also attention.

#### THE HORSE AT WORK.

Horses are kept for pleasure or business ; in either case they are called upon to perform work, though of different degrees of severity and regularity, and under widely different circumstances. The nature of the work consists in either carrying a weight or dragging a load, and in the performance of these there is by no means uniformity of ideas as to what constitutes a fair day's work.

*Wear and Tear.*—As a general rule it may be said that the capacity of the horse for work is overestimated, often from ignorance, frequently from indifference; the only standard by which his capacity for work can be measured is by his condition, it being assumed if there is no loss of condition the work is not excessive. Nor are we disposed to suggest that this rule is not a good practical guide, and perhaps in the present state of our knowledge the only one available, but there is another aspect of the case, and that is that though the general condition is a sure index of work as affecting the muscles, it is no guide as to the influence of work on the limbs.

The limbs of horses suffer from disease out of all proportion to the other part of the body, and broadly speaking these diseases are due to work. Less work would mean less lameness, and the question is whether it is possible to tell when horses are performing work which though not beyond their muscular effort is in excess of what their limbs can perform.

As a matter of fact the highly trained eye is capable, as a rule, of forming a fairly correct judgment on these matters, and such judgment is based upon the age of the horse, the make and shape of the limbs, the nature of the work and class of ground over which it is performed, the weight carried or drawn, and finally the condition presented by the limbs. These several factors have all to be con-

sidered, a young animal cannot perform the same amount of work as an adult. Limbs of defective conformation lend themselves to disease, such for instance as excessively sloping or very upright pasterns, or a horse back on the knees, or small in bone and tendon, or legs which are not true in direction or too close together. But in spite of these defects it is remarkable the amount of work the most ill-shaped legs may perform without the usefulness of the animal being interfered with, though this remark does not apply to limbs which are not true in direction or are placed too close together, cardinal faults certain to lead to trouble.

The nature of the work is a most important factor, and presents so many phases that it would be impossible in the space at our command to fully detail them; but it is a very obvious cause of trouble and appeals to ordinary common-sense; for example, a light horse performing heavy draught, or a heavy horse performing saddle work, are extreme cases but illustrate the point.

Heavy wet ground, irregular ground, hard roads, and sandy roads are also factors which can readily be grasped as exercising an influence in the production of disease; on the other hand the influence of weight either carried or drawn is not so easily grasped by the lay mind, and is the most important factor of those mentioned.

Finally, the condition of the limbs tell a tale to the practical eye which nothing can explain away. A young horse showing in his limbs signs of work is being worn out before his time, no matter how good the muscular condition may be. The early signs of work are indicated by the legs getting puffy or swelling after work; later the fetlock joints enlarge, windgalls form, the pasterns become more upright, in the hind legs the fetlocks shoot forward, and in the final stage the legs bend forward at the knees.

When in practice we speak of the legs showing signs of wear, it is the above in any form or modification to which we allude.



All this would appear to have more direct application to the cause of lameness than to the question of work, but it is impossible to separate these conditions; they overlap so completely that a consideration of one necessarily entails dealing with the other, though it is our intention in a subsequent section to deal exclusively with the prevention of lameness so far as this is under direct control.

The production of labour is what the investor expects for his purchase money and the cost of maintenance. It is not, therefore, altogether a matter for surprise that selfishness at once becomes evident, as it does in all human affairs where an investment is made. As a matter of fact selfishness is here a costly feature, it leads to living flesh and blood being regarded in the light of a machine, and so defeats its own ends. In this respect there is little to choose between the rich and the poor, the hunting man will ride his horse to death should the necessity arise, the poor man will work his horse to death. It is no exaggeration to say that thousands of horses are annually disabled or killed through overwork, or work for which they are not in 'condition.'

#### CONDITION.

This brings us to a consideration of one of the most interesting practical features in horse labour, viz., 'condition,' a term freely used, well understood, but most imperfectly applied.

Condition is fitness for work, and is obviously of as many different degrees as there are varieties of work. The condition of a racehorse is very different from that of an ordinary riding horse; the condition of a horse that never goes out of a walk is different from that of one which performs its duties at a trot. Condition is fitness for the class of work required; its very highest development is seen in the racehorse, and next in the hunter; its most useful form exists in the industrial classes; its almost entire absence may be found in the pampered horses of the wealthy.

It is usual to judge condition by the state of the muscular

system, but this is only an index to the entire change which an animal's body has undergone in being made fit for work; the respiratory, circulatory, nervous and other systems are affected by the change. The heart's action as the result of work is rendered more active, a larger amount of blood passes into the vessels, and a larger amount through the lungs.

One of the first things to occur in 'condition' is the establishment of a concordant action between the heart and bloodvessels; there must be no difficulty in the passage of the blood from right to left heart, and none must exist between the heart and the vessels into which its contents are pumped.

While this reciprocal action is occurring other profound changes are taking place; the body fat is being largely used up and not replaced; the muscular system is growing in bulk, the muscles themselves become firmer, closer in texture, and the withdrawal of their fat maps out many of their contours. The tendons and ligaments throughout the body, but especially below the knees and hocks, become tense and firm, their outline clearly marked. The skin from sweating easily in the 'soft' horse gradually loses this disposition, so that quite a considerable amount of work can be done without any or only slight action of the skin; in this matter both pace and the temperature of the surrounding atmosphere are important factors in the production of sweat.

The respirations of the 'soft' horse which has been worked are often irregular, jerky, and take a long time to settle down. As the animal improves in condition all irregularity of movement and jerky expirations cease, and the breathing after work soon falls to normal. Respiration is a very important measure of the animal's condition. Distressed respirations are due not only to the fact that the lungs cannot get rid of the blood as fast as they receive it, but also to the fact that its carbonic acid is not fully removed, so that the muscles are not properly supplied with

oxygen. This produces exhaustion, while at the same time the effect of carbonic acid on the respiratory centre, and the engorgement of the heart, is to set up increased difficulty in breathing.

We cannot here enter into all the physiological problems concerned in training, we have touched on those of the greatest importance, viz., the conditioning of the heart and bloodvessels, skeletal muscles, and the respiratory problem, all of which are of considerable complexity, and of which we only know the beginning and the end.

It is quite impossible to exaggerate the influence of condition, no horse intended for work can be safely worked in its absence, it is unfair to the animal, and a species of cruelty such as the ordinary lay mind fails to recognise until pointed out.

What man that has been living a life of idleness can suddenly be put to hard work? Common-sense dictates that work must be light in the first instance, and gradually increased as the muscular and circulatory systems improve in tone. Exactly the same thing applies to horses, only to a more marked degree; for example, if a man is in training for a race he only has to carry the weight of his own body, but a horse has to carry not only the weight of its own body but that of its rider. In all cases of the conditioning of horses this must not be lost sight of, as a matter of fact it is never remembered, the only weight to which we pay attention is that which is placed on the animal's back or behind it; it is completely forgotten that there is the horse's own body-weight to consider, which he must first get fit to carry before any work can be expected from him.

Any calculation of the effort exerted to carry the body is a complex problem, and for the horse, has never, so far as we know, been determined by mathematicians; but it has been shown in the case of man that one twentieth part of the body-weight is expended in propelling it at three miles an hour on a level surface. This number is called the

co-efficient of resistance, and as shown in the following table it increases with the velocity :

Velocity in miles per hour.	Co-efficient of resistance.	Velocity in miles per hour.	Co-efficient of resistance.
3	$\frac{1}{20.59}$	8	$\frac{1}{9.60}$
4	$\frac{1}{16.74}$	9	$\frac{1}{8.68}$
5	$\frac{1}{14.10}$	10	$\frac{1}{7.52}$
6	$\frac{1}{12.18}$	11	$\frac{1}{7.27}$
7	$\frac{1}{10.72}$	12	$\frac{1}{6.73}$

So that in the case of a man weighing 150 lbs., the effort necessary to move the body at three miles an hour is about  $7\frac{1}{4}$  lbs. for each step taken.

Applying these figures to the horse, and assuming the body-weight of the animal is 1000 lbs., while the pace is five miles an hour, the animal would have to exert a muscular effort of about 71 lbs. at each step to carry its own weight; while at 10 miles an hour an effort of 133 lbs. is required for each stride.

In the above table it is assumed the horse is working on a level surface; in going uphill it is obvious much more effort is required, while in jumping the entire body-weight has to be lifted.

The table showing the co-efficient of resistance is mainly academical, but it is introduced to impress the important practical point of the great effort required by the muscular system to carry the animal's own body-weight, and further is intended to illustrate a point on which we shall presently insist, that all horses must in the first instance be got fit for work by carrying nothing more than their own weight.

An animal out of condition may be so from overfeeding and insufficient work, or from too much work, or from too much work combined with insufficient food, or finally as the result of lameness or sickness.

The appearance presented by each of these will naturally

differ; the overfed and insufficiently worked horse is probably as round as an apple, not a muscle contour can be seen; beneath the skin is a layer of fat over the whole surface of the body, the face and legs below the knees and hocks alone excepted.

The skin when moved to and fro with the hand feels like blubber, the points of the fingers may be forced into it; the abdomen during the walk waddles from side to side, owing to the weight of its contents, and the inability of the abdominal muscles to hold them together. Very little exertion causes respiratory distress and profuse sweating, the sweat being lathery and very unlike that of the horse in hard condition.

An animal in this state if called upon to do an ordinary day's work will suffer from laminitis or pneumonia, perhaps both. Pneumonia is almost essentially a disease of young horses, and no matter what the organism is that is responsible, or where it is derived from, or how closely allied pneumonia may be to strangles, the fact stands out pre-eminent that one of the most important causes of pneumonia is exhaustion following overwork in young 'soft' animals.

The horse out of condition from too much work, but receiving ample food, is merely 'stale,' it is difficult to find a more suitable word to express the state. In training racehorses it is one of the points looked for, as its early recognition is of the utmost importance. If in this condition the training be continued, the animal's speed falls off, and great damage may be done, whereas a few days' rest or light work causes the system to immediately respond. A hunter may be 'stale,' most of them are by the end of the season, especially if they possess that serious fault in a horse, viz., being too good. In such a case the staleness is the result of long continued overwork, which the limbs show in the most unmistakable manner, while the animal's action tells its own tale. This form of staleness is met by a few months' rest.

When overwork and insufficient food are combined, the

effects are evident very early, there is loss of muscle, a 'tucked up' condition of abdomen, lassitude, and if the causes in operation are carried beyond a certain degree, as they may have to be in military service, a point is at last reached from which recovery is either impossible, or only after months of rest and careful feeding. It is not necessary, however, to imagine anything as severe as this; hard worked and underfed horses are seen daily in our streets, principally in the possession of the small owner with no knowledge of the management of horses or the amount of food they require; with him it is ignorance, in many other cases it is indifference, and in large establishments is an unflinching indication of some irregularity in the feeding arrangements, frequently of the nature of speculation.

The last class of horse we have to speak of out of condition is the one which has either suffered from sickness or lameness, or, at any rate, for veterinary reasons has been unable to work. The appearances presented by these will naturally vary with the cause which threw the horse out of work; if from lameness, the animal may resemble the pampered and underworked horse we first described; while if it is a recovery from pneumonia or other debilitating disease, the appearance presented is that of the overworked and underfed horse mentioned above.

Every animal on recovering from sickness or lameness must be 'conditioned' before being sent to work; in this way we secure not only that the horse is made fit for work, but also that our treatment in the case of lameness has a fair chance. It is obvious that a horse rendered sound by rest and treatment, will probably be a lame horse once more if taken into ordinary work, until the cure becomes consolidated by 'condition.'

It is impossible to overrate the importance of these remarks. To take a horse out of a stable where he has been resting for lameness three weeks or a month, perhaps much longer, and give him a day's work without the slightest preparation is simply criminal; it can have but one result, and the man who produces that result does not

blame himself for his folly, but his veterinary attendant for his want of skill.

Condition can only be obtained by degrees, it is a gradual process beginning with light work, and slowly increasing it to the amount required by the purpose the horse is intended for.

In the first instance it must begin with walking exercise; in fact, condition begins with it and ends with it; it is walking exercise which develops muscles, which gets rid of fat, and lays the foundation for the reciprocal action of heart and vessels, vessels and lungs. It is walking exercise which 'conditions' the laminae of the feet, and which braces tendons and ligaments. Under all circumstances whether faster paces are being employed or no, walking exercise still forms the bulk of the work that horses have to perform to fit them for the hardest muscular effort that any animal is capable of.

This is a fundamental principle imperfectly appreciated; trotting and galloping only represent a portion of the work performed by the horse in training, and then only performed when he is absolutely fit to undergo it. Walking alternated by steady short trots, is the chief means of developing muscles and rendering horses fit.

Both walking and trotting should in the first instance be done without any weight on the back, the effort exerted by the horse in carrying his own body-weight is at first quite sufficient; later on in the case of a saddle horse or light draught horse a weight may be put up, but the whole process must be gradual.

These principles equally apply to draught horses; the heavy horse seen on London streets is gradually introduced to his work. Purchased at five off, the first work is of the lightest kind; for three months three half-days a week is all that is expected, and it is only gradually, as they become conditioned and accustomed to hard food, that full journeys are performed.

If 'condition' is the secret of keeping horses workably sound, then the secret of condition is the gradual intro-

duction of horses to their work. They must not be forced; forcing defeats its own object, and can only have one termination and that is disappointment. The whole process is a gradual one; time, patience, and for the higher form of condition, viz., that required for racing, skill, profound judgment, and experience, are required; for the lower forms of condition, viz., for ordinary saddle and harness work, all that is needed is time, patience, a knowledge of horses, and sound common-sense.

In the conditioning of horses there is one feature not yet alluded to, and that is the amount of 'condition' which any particular horse can attain. This is a variable quantity depending on the personal equation. There are some horses which from their condition of extreme nervous irritability can never be trained or got fit; we are now speaking almost entirely of the higher forms of condition for racing and hunting. There are others of naturally delicate constitution, whose limit of power is soon reached, and if pressed beyond it go off their feed for a day or two, in consequence of which it is practically impossible to get them 'fit.'

The amount of work each horse is capable of doing, when he has yielded his maximum, and when he shows the slightest deviation from his proper form, are features in the training of horses only learned by long experience. Even that experience is lost unless implanted on a judgment which is almost intuitive, hence the training of racehorses is in the hands of a few experts possessing extraordinary powers of judgment. This judgment they are no more able to transmit to others, than is the jockey who in a few rare instances becomes a remarkable judge of pace, and of knowing what he can really get out of a horse, and the right way and time of doing it.

This acute degree of perception is not required for the ordinary conditioning of horses, but it is obvious that a knowledge of what an animal is capable of yielding, for how long the work should last, and the nature of the pace, are quite as essential as in the higher form of training.



There is a look of 'fitness' about a horse in condition which is not easy to describe; a bright active appearance, an absence of fat, firmness of the muscles especially those of the neck, a bloom on the coat, and generally an appearance of a high degree of health. It is not possible to maintain a horse in the highest form of condition for long, but good sound hard general-utility condition is easily maintained, and just as easily lost. A horse thrown out of work for a week or fortnight has lost hard-working condition, and this must be restored by exercise before he is fit for the work he performed before being 'thrown up.'

The danger of working horses out of condition, or of giving them more work than their condition warrants, is manifold. The most common general results are sprains and laminitis; but almost any form of lameness may have its origin in want of fitness for work.

The hygienic aspect of sprains is considerable, for it may be broadly stated that no horse can suffer from a sprain that either has not been worked until exhausted, or is unfit for work through absence of condition. This is a most important statement with far-reaching possibilities, for if correct it is evident that the production of sprains is a matter which is largely under control. The correctness of the statement may be absolutely accepted; sprains in horses arise from want of condition and exhaustion. It is necessary to combine these two causes, for though the horse out of condition suffers from exhaustion, yet the horse in the highest condition will also suffer from exhaustion if the pace be too severe or the weight carried be too great.

Horses do not sprain themselves in the stable, and in this statement we refer to the common seat of sprain, viz., flexor tendons and suspensory ligaments; we exclude those rarer forms of sprain, say of the ligaments of the hip, from a bad slip in the stable.

Sprains of the back tendons and suspensory ligaments only occur when a horse gets tired; it is the function of the muscles of the limbs to propel and take the concussion of the body, and this they are enabled to do by their con-

tractility and elasticity. Neither ligament nor tendon are elastic; when muscles tire they lose their elasticity, and the strain they should take is thrown on the tendons and ligaments; these yield to the strain either by bundles of fibres giving way, or the greater part of one or more tendons rupturing. In spite of the difference in their physical characters, muscles are stronger than tendons; a ruptured muscle is rare, a ruptured tendon common.

It is evident that sprains do not occur at the walk, rarely if ever at the trot, seldom at the canter, nearly always at the gallop. The reason of this is explained by what we know of equine locomotion, it is only in the canter and gallop that a single fore leg is called upon to propel the body; in the case of the gallop it is capable of propelling it over twenty feet, in the canter the propulsion is about half that amount, and, further, owing to the slowness of the pace the horse can easily change the leading leg when its fellow gets tired. At this point we may conveniently note that all horses intended for riding purposes should be taught and encouraged to change the leading leg in the canter, and if possible in the gallop, as a safeguard against sprains. It is a lesson that requires to be taught early in life, for horses, like human beings, have a preference in the limb they employ.

We have said a horse may be in condition and yet suffer from sprain, but in such a case it is invariably the result of muscular fatigue, the result of the pace being too fast or the weight too much.

The importance of conditioning horses which from any cause have been thrown out of work, is now seen to be of the utmost hygienic advantage, but before concluding this subject it is well to look at the next great cause of inefficiency from want of condition, viz., laminitis.

The laminae of the feet are as capable of loss or gain of condition as the ordinary skeletal muscles. When the muscles of the body are flabby, wanting in tone, and easily fatigued, the laminae of the feet are in a similar condition; the result is that laminitis frequently supervenes when

horses out of condition are worked. Stating the case broadly, we may say that laminitis is a disease which may positively be prevented by attention to condition.

Early in this section we spoke of pulmonary trouble following on want of condition, and elsewhere\* we have recorded the fact that if horses be galloped even a short distance, when in 'dealer's condition,' pneumonia will supervene; in fact by these means the disease may almost be produced at will. But there is a form of pulmonary trouble met with in the conditioned horse which results from being over-galloped; the term pulmonary apoplexy is a very suitable one, for the lungs are unable to get rid of the blood as fast as it is received, and the horse finally drops. This is the condition which exists when a man gallops his horse to death in the hunting field, while the cruelty of the proceeding is covered up by that convenient term 'sport.'

It must not for one moment be imagined that the whole of the lameness due to want of condition is comprised in laminitis and sprains; it is quite possible, though we have no direct evidence, that bones may become conditioned just as muscles and vessels are. Greater attention to the question of condition might reduce the production of lameness due to bone and joint diseases, which in horses is only too frequent and the treatment unsatisfactory.

It may take three months to get a horse fit for the hunting field, during which he should be gradually accustomed to perform towards the end of his training twelve to sixteen miles daily, which is best divided into two periods of two and a half to three hours in the morning, and an hour in the afternoon, depending on the distance travelled.

Continual walking is very trying for horses; the exercise should be arranged so that a certain amount of trotting (that is assuming horses are fit for it) should be done every hour. By this means other muscles are brought into play, and the effect of trotting is refreshing.

\* 'Pneumonia and Pleurisy in the Horse': *Journal of Comparative Pathology and Therapeutics*, vol. x., 1897.

Intervals of rest should be arranged for during the exercise, especially when horses are very unfit. A halt of ten or fifteen minutes every hour should be given; later on as the animals get harder the rest intervals may be less, but under any circumstances a rest every two hours is desirable.

The exercise of each horse must be regulated according to his strength; signs of brushing or forging must be looked for as indicating leg weariness, and the former should in every case denote that less exercise must be given.

The animals should not be purposely sweated, the fat will all come off with patience; it is no use trying to hurry horses into condition, it only defeats its own object.

Hacks and harness horses may be conditioned in about two months, but no definite period can be laid down for any animal, so much depends upon the personal equation.

Horses intended for draught may in the course of a week wear their harness at exercise in order to accustom them to the friction; in fact, the collar might be worn from the beginning of their training, for the freedom of skin from chafes is enormously influenced by condition, and the sooner the collar is got on the better.

Later, when draught work begins, it must at first be steady, no loads, frequent rests, good roads selected; places like the shoulder and tail should be examined repeatedly to see no friction is occurring, and in this way the animal is gradually introduced to its work, which should begin with a load every other day for a short distance.

We have not touched on the question of conditioning and training horses for military purposes; the principles are identical with what have been previously considered, but the details differ; these will be considered in the chapter on Military Hygiene.

## THE AMOUNT OF LABOUR HORSES ARE CAPABLE OF PERFORMING.

We now come to a question on which very little exact information exists, and on which great divergence of opinion may be held. If the question were put in the form 'What amount of work can a horse perform?' the answer would be that it first depends upon whether it is intended he shall carry a weight or drag one; but under either circumstance the daily work is the product of three quantities, viz., the effort exerted, the velocity with which it is performed, and finally, the length of time daily during which the work is continual.

The question of 'effort' is an extremely interesting one from the physiologist's point of view, and obviously differs depending upon whether it is that entailed in carrying a weight or in dragging a load; in either case the effort capable of being rendered is governed by the animal's body-weight.

Dealing first with the weight carried, we have shown\* that the mean ratio of a horse's carrying power as compared with his body-weight is as 1 : 5·757. In other words it takes 5·757 lbs. of the animal's body-weight to carry 1 lb. of weight on the back during severe exertion. The original paper must be consulted for the methods employed in obtaining these results. The fact remains that a horse cannot effectively carry a greater weight than, in round numbers, about one-fifth to one-sixth of his body-weight. So that in order to arrive at the weight an animal should carry all that is required is to divide his body-weight by 5·757. Assuming his body-weight was 1,000 lbs., this would mean he was up to nearly twelve and a half stone exclusive of saddle, while if the animal is not intended for hunting, or exceptionally severe saddle work, one or two stone may be added to this, depending entirely on the velocity at which the work is performed.

\* 'Relation between the Weight of a Horse and its Weight-carrying Power': *Journal of Comparative Pathology and Therapeutics*, January, 1899.

These results are perhaps of more interest from a military than from a civil point of view. If a hunting man buys a horse that is not up to his weight he is the only person that suffers inconvenience; but the matter is very different when the effective weight-carrying power of military horses is concerned. It then becomes a fundamental question affecting the entire usefulness of the 'eyes and ears' of an army, and the matter will from this point of view be alluded to again in dealing with army horses.

The amount of weight which a horse is capable of pulling is much easier of determination. All that is required is a dynamometer. Yet reliable observations have hitherto not been very numerous.

Watts' classical experiment of a horse pulling 150 lbs. a distance of 220 feet every minute for ten hours a day, has been generally accepted as the normal capabilities of a horse, whereas it is not so. That this force can be exercised is undoubted, but it is far too high a standard to adopt for general work.

The first thing to ascertain is the extreme limit of a horse's power—his maximum muscular effort—and in a series of observations on this point which we have undertaken,\* it was found this varied from 65·6 per cent. of the body-weight to 78·5 per cent., the former group being recorded as indifferent pullers, the latter as excellent. If, therefore, we say the maximum muscular effort a horse can exert varies from 68 per cent. to 78 per cent. of his body-weight, it will not be far from the truth. So that a horse weighing 1,000 lbs. can exert a steady pull of from 680 lbs. to 780 lbs. for a few seconds; it is, in fact, the limit of his power.

The body-weight of a London dray horse is from 18 to 21 cwt., while that of a Glasgow horse is from 16 to 18 cwt.†

The next point for consideration is what proportion of a horse's body-weight may be effectively utilized in draught,

\* 'Maximum Muscular Effort of the Horse': *Journal of Physiology*, vol. xix., 1896.

† 'Heavy Horses': *Live Stock Handbook*, No. 3.

and this question can only be answered by saying that it entirely depends upon the pace at which the work is performed. We will take two extreme cases of draught work: the mail-coach horse of sixty years ago, and the plough horse of to-day. One worked for 50 minutes on an 8 mile stage, exerting a 40 lb. pull, or 4 per cent. of his body-weight; the other works for 8 or 9 hours a day in a plough, the mean draught being 168 lbs., and the pace  $1\frac{1}{3}$  miles per hour. In this last case the pull is 11 per cent. of the body-weight (taken at 1,500 lbs.); the average amount of daily ploughing is one acre in 9 hours, and this with a nine inch furrow slice gives a distance of 12 miles for the day's work.

In these two cases one horse works for 50 minutes at rather more than  $9\frac{1}{2}$  miles an hour, and exerts a force of 40 lbs.; the other does 9 hours work at  $1\frac{1}{3}$  miles an hour, exerting a force of 168 lbs. The one horse is called upon for a traction effort of  $\frac{1}{25}$  of his body-weight, the other for an effort of  $\frac{1}{5}$ .

Although the force exercised in draught is so easily measured, there is a great difficulty in saying at any particular moment what it amounts to; the fact is that, excepting on a smooth, perfectly level, steel road it is varying every moment, and this is due not only to friction between the road and the wheel, but between the wheel and the axle. The latter friction is due to the weight of the load and is affected by the size of the wheel, so that the larger the wheel the less the friction.

The friction between the wheel and the road depends upon the nature of the road. The force necessary to move 1,000 lbs. in a light four-wheeled cart is:—

			Lbs.
On a hard dry turnpike road	...	...	$30\frac{1}{2}$
The same road, dirty	...	...	39
Hard compact loam	...	...	53
Ordinary road	...	...	106
New gravelled road	...	...	143
Lone sandy road	...	...	204

This table is very instructive and tells its own tale.

Experiments have been made to determine the effort required to move a load on London streets. A gross load of 4 tons was drawn at a speed of from 2 to 6 miles an hour, and the following were the mean results in traction force required per ton :

			Lbs.	Lbs.
Macadamized surface	...	...	40·7	to 44·29
Asphalt	...	...	39·0	to 39·32
Wood pavement	...	...	33·62	to 36·63
Granite sets	...	...	26·20	to 27·00

These experiments were made on a level road ; when the draught is uphill a portion of the weight of the carriage must be added to the draught on the level. For example, if the draught on the level for a carriage weighing 12 cwt. amounted to  $1\frac{1}{2}$  cwt., and a hill rising one foot in four has to be ascended, then  $\frac{1}{4}$  of the weight of the carriage must be added to the draught on the level, viz., 3 cwt. must be added to the original  $1\frac{1}{2}$  cwt.

In the streets of Glasgow an average single horse load, inclusive of the dray, is  $3\frac{1}{2}$  tons ; in London a dray horse is not required to pull more than  $2\frac{1}{2}$  tons ; but the horse in the North does his work at a walk, whereas in London he has to do it at a trot.

We have referred previously to Watts' classical experiment whereby he determined with brewers' horses what is known in engineering as *Horse Power*. He found that a horse was capable of pulling a weight of 150 lbs. to a height of 220 feet every minute ; this is equivalent to 33,000 lbs. lifted one foot high every minute ( $150 \times 220 = 33,000$ ), and this is adopted as the unit of work in all engines.

There are many reasons which lead to eight hours being selected as the length of the working day, and it has been considered by those not conversant with the practical management of horses, that a fair day's work for a horse is 33,000 lbs. (14·7 foot tons) lifted one foot high every minute for eight hours ; but this is far too high for general application, it amounts to 7,000 foot tons per diem, which is a very hard day's work. Further, though at slow draught



work this exceedingly heavy amount might be performed yet for the faster paces it is impossible.

Morton,\* from a series of observations made on the draught of ploughs, and statistical data furnished by several farmers, gives a table showing the amount of work per horse in farm labour. Taking the mean of Morton's table, it amounts to 3,795 foot tons of work per day of eight hours. The remark that though the draught of an ordinary plough may be one-horse power per head per minute, yet there are various reasons why the effective work of horses barely exceeds half the calculated work.

We believe the normal daily work of the horse to be about 3,000 foot tons; that this is often exceeded is undoubted, but it is seldom that horses are not overworked. It may as a rule be said that, with few exceptions, they are worked up to the limit of their power, and frequently beyond their power.

In fixing 3,000 foot tons, if we have erred it is on the safe side, this amount of work will not shorten the useful life of a horse, nor wear out his legs before their time. That it is impossible to fix an amount of daily work which all horses should perform is manifest; many will do more, some less than the standard, the personal equation plays an important part, and the willing horse is sure to be imposed upon.

The following table will convey an idea of 3,000 foot tons of work. It assumes the weight of the horse with the load carried or drawn amounts to 1,000 lbs. :—

					Distance travelled.
Walking at	3 miles an hour for	8·7 hours	...		26 miles
"	4	" "	5·3 "	...	21 "
"	5	" "	3·7 "	...	18 "
Trotting at	8	" "	1·5 "	...	12 "
Cantering at	11	" "	1 "	...	11 "

But the question is by no means as simple as this table might indicate. This assumes a level surface, a good road, and an even pace being maintained; in fact it assumes a combination of conditions which are rarely met with, but

\* 'Labour on the Farm': Mr J. C. Morton.

which in the speculative subject under discussion we are compelled to assume as an approximation to the truth.

#### DISEASES AND ACCIDENTS DUE TO WORK.

As might be expected this is rather a formidable group of affections, as it includes among other things the question of lameness; the diseases may be classified as those of respiration, digestion, and locomotion.

When an animal with a heated and wet skin is left standing on the road with a cold wind blowing, catarrh, pleurisy, or pneumonia may result. It is to guard against these, among other troubles, that we have insisted on horses being got in condition for work, and further, on working horses being clipped. Both of these as preventive measures are of the utmost importance, for the conditioned and clipped horse sweats slightly, and the risk is consequently very small.

Protection from the weather should be afforded all draught horses, by means of a loin cloth arranged to cover the back, loins, and quarters. It should rest on the harness rather than on the skin, so that air may exist between it and the skin, and in this way sweating from an impervious covering is not produced; if allowed to rest on the skin the part is kept bathed in sweat.

Animals which have been out on a cold, or especially wet and cold, day, should receive particular care on their return from work. This should include thorough and *rapid* drying, a good warm bed of straw provided, the chill taken off the drinking water, and a good feed provided. If the latter is refused some gruel should be prepared and given in the ordinary way; if the horse will take this with his drinking water so much the better.

If the horses wear rugs, provision may be made before the animals return to have the rugs aired before a fire, so that a warm dry rug is available at once.

If sufficient labour does not exist to dry the horses rapidly (it takes two men to a horse) they had better at

once be blanketed up. If blankets are not worn the animals must be walked up and down until cool, and when put in the stables they must be well dried; it is desirable for an hour or so to keep the doors and windows closed on the windward side, in order to avoid a stream of cold air playing on their bodies.

Horses that return from work exhausted are best dealt with by means of gruel and a good warm bed. There is nothing warmer than straw, and a well made bed will induce rest, after which the appetite frequently returns, though sometimes not for a day or two.

Working horses on a full stomach, especially of bulky food like hay, is a prolific source of trouble. With all horses the pressure against the diaphragm may lead to rupture, while rupture of the stomach itself is only too common.

The means of preventing these troubles have been fully gone into in the chapter on Food (p. 139), all that is necessary here is to emphasize these points. A fall in draught, or even a bad stumble, may on a full stomach lead to rupture of the diaphragm, while a rupture of the stomach is produced by some disturbance of digestion, frequently associated with overdistension and aggravated by work.

We are not prepared to define the relationship existing between work and colic. The fact, as pointed out by us some years ago, exists.\* Horses that are not worked do not suffer from colic; bowel and stomach trouble is largely though not entirely due to work. Quite apart from such obvious causes as irregularity in feeding and watering, and hard and prolonged exertion, there are other more subtle causes, which we cannot define, connecting colic with work. It may be through the nervous system, and this is supported by the fact that twists, displacements, and invagination of the bowels are probably wholly nervous in origin.

\* 'Influence of the Time of Day in the Production of Colic': *Veterinary Record*, vol. v., p. 616, 1892.

Animals performing long hours of slow work may be watered and fed frequently in small quantities, in fact their work necessitates it. Animals performing fast draught work, as cab horses, are watered and fed during their comparatively long intervals of rest. Horses performing fast saddle work may be watered in small quantities during work, but should only be fed with small quantities of concentrated food like grain; bulky material like hay being entirely omitted, owing to the distension of the stomach and its pressure on the diaphragm.

In countries like South Africa where horses travel considerable distances daily, and with care and condition may do fifty miles a day for several days in succession, there are certain rules, the result of experience, which are never neglected. One is that the horse or horses are not worked at a stretch for more than two or three hours, after which there is a rest for an hour, during which the animal must lie down and roll and empty his bladder. If the latter function is not performed no further progress is made until it takes place. The Boers are wonderful horse-masters, and they know how to get every ounce out of a horse without unduly distressing it. Fifty miles a day for a Boer Commando during the war was a frequent performance; eighty miles was regarded as a long march, but quite within the capabilities of a horse-master. Of course British Cavalry cannot approach this until they know how to 'live on a country,' and the horse is asked to carry nothing but the rider and his weapons.

Sore backs and shoulders and wounds of the mouth, though not diseases of locomotion, are conveniently alluded to here as injuries resulting from work. Owing to their great importance they will receive special consideration in the section devoted to Saddles and Harness.

#### STUMBLING AND BRUSHING.

Defective action during work is very liable to lead to serious trouble, especially when a horse gets tired. The

most common defective action is stumbling. The causes in operation to produce this depend upon whether it is a draught or riding horse, though there are causes common to both classes.

A riding horse stumbles when he gets tired, but this obvious cause need not engage our attention. He may stumble from defective action, the most common form of which is an inability to carry the limb forward at a sufficient height above the ground to clear all ordinary irregularities. This inability may be due to natural clumsiness, or to stiffness of the joints, especially the knee and fetlock, by which the flexion is slightly reduced. A very slight loss of flexion at knee or fetlock will produce an inveterate stumbler.

Saddle horses may also stumble from the mechanical interference produced by the saddle pressing on the blade bones. A certain amount of freedom is required for the scapula, and if saddles are so constructed as to limit this freedom, it is impossible for the leg to be carried well and smartly to the front (see p. 817). This cause of stumbling among army horses was pointed out by us nearly twenty-three years ago,\* but does not appear yet to be generally recognised.

Horses stumble if their feet are too long; it is an exceedingly common cause of falling, especially when an animal is getting leg weary. If records are kept of all broken knee cases brought for treatment, it is astonishing how many occur either immediately following shoeing, or when the animal has been allowed to go over its time and requires shoeing. At first sight it seems strange that two such opposite conditions should give rise to the same results. Yet the matter is very easily explained. When the animal has gone over its time for shoeing the toes are long and liable to cause tripping; when tripping results after shoeing it is due to the new shoe not being worn away at the toe and so catching in the ground.

\* *Quarterly Journal of Veterinary Science in India*, vol. i., 1882.

Stumbling may result from brushing, while brushing results from want of condition or more commonly malformation. The horse with toes turned out and elbows turned in cannot help but brush, as he throws his feet inwards during progression. Methods of prevention, such as will be referred to in the section on shoeing, can never do anything more than give partial protection; they cannot prevent the toes being turned out and the feet deliberately thrown inwards at the trot. Such a conformation with a narrow chest must invariably lead to brushing.

Young horses out of condition will brush all round, even when their limbs are properly put on; but as they gain condition this entirely passes away, and unless there is good reason for it, their shoes should not be altered. All they require is to have their limbs protected.

Brushing from bad shoeing or want of shoeing will also occur; by bad shoeing we mean shoes being fitted too full on the inside, and by want of shoeing is meant the clenches being raised by the forward growth of the foot and left projecting, or a general spreading of the foot due to overgrowth and neglect of shoeing. A projecting clench or a shoe fitted too full are only likely to cause damage to horses that naturally 'go close,' or are very tired.

The nature of the ground has a good deal to say to stumbling. Animals that move over a level and hard pavement, like that met with in cities, do not pick their feet up any higher than necessary. It is a time-saving arrangement on a surface containing no projections, but a very dangerous proceeding where irregularity in the surface occurs.

Many horses, like Arabs, have naturally very low action at the walk, but though they frequently 'peck' it is seldom they come down. The fact is they become very clever at recovering themselves after a stumble, their movements to recover being quicker than the actual stumble. They are, however, very unpleasant horses to ride at a walk, especially as they expect stumbling to be followed by punishment. At the trot they are frequently perfectly safe.

Horses that 'speedy cut' may stumble. The condition of limb which leads to speedy cutting is the same as that which induces 'brushing,' the only difference being that the 'speedy cutter' picks his feet up higher, and hits himself inside the knee instead of inside the fetlock.

It is obvious that stumbling due to malformation of the limbs can only be partly met; the more frequently a horse hammers his fetlocks, and the larger they become, the nearer they are brought to the opposite foot, and the less flexion they possess; as flexion is reduced stumbling is increased. Such animals should receive permanent protection to the fetlock joints, and a special kind of shoe which will be alluded to later.

Stumbling due to scapular pressure is very easily remedied, by having the saddle cut well back. Stumbling

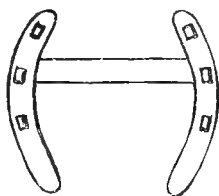

Fig. 196.—Shoe to Prevent Stumbling. The whole of the toe is removed, and the shoe held together by a transverse bar.

due to overwork and leg weariness can only be dealt with by attention to condition and food. That which is due to a naturally low action can be corrected by attention to shoeing, and the use of a special kind of shoe.

Fig. 196 shows a shoe used by us for many years, which with naturally clumsy horses with low action has given absolute satisfaction.

It will be observed there is no toe whatever to the shoe, so that to catch it against the ground is impossible. The shoe is prevented from being driven back by quarter clips. In making it for the first time, attention should be paid to the part of the toe of the old shoe which the horse wears away; if worn in the centre, then the gap in the shoe of Fig. 196 should be left at the centre; but most horses wear

to one side of the centre, and, whichever side it may be, is the one in which the gap in the toe of the shoe should be greatest.

The shoe should be made in the ordinary way and fitted; the cross-bar is then welded on, and finally the required portion of the toe cut out, the cut edges of the toe being bevelled off just like the heels of the shoe.

There are other methods of shoeing a stumbler, of which the well-known 'turned up' toe is an excellent shoe.

A horse may be a chronic stumbler and yet never come down; another horse may never have stumbled in its life, but one day falls without warning and breaks both knees.

It is the latter class of stumbling we are now going to consider, viz., the horse that really comes to the ground and damages its knees. The causes of this are comprised under those already considered with certain additions. For instance, a horse placing his foot on a loose stone may come down, especially if it be a thin sole, and actual pain results from the pressure of the stone. A horse may fall as if shot when there is no evident cause, though in some such cases we have known leg weariness to be the cause.

A horse is more liable to fall at a trot than at any other pace, and he does more damage to his knees when at the trot than at any other time.

He may come completely on to his head at the canter without touching his knees, though he cuts his forehead; he may fall at the walk and merely graze the parts.

When an animal saves itself from falling it is due to the opposite fore leg, though both the rider and driver take credit to themselves for 'holding the horse up.' A horse may be kept from stumbling by taking a short hold of his head, by which means he is compelled to pick his fore feet up, and bring his hind legs under his body. But if he once blunders no holding up will save him, he saves himself or fails. Evidence of this is the rarity of a single broken knee. Obviously if a horse falls and breaks one knee its fellow could never have been on the ground; it is a rare condition, the most common one is that the opposite fore leg



having failed to enable the horse to recover, he goes down on both, and so complete is the collapse that he frequently cuts the inside of his upper lip with the incisor teeth, through his mouth coming in contact with the ground.

The slower the pace the better chance the animal has of saving himself. The slope of the ground has also a great deal to say to it, a horse may recover himself going up a rise that would certainly fall if descending a hill. More broken knees occur going downhill than happen on a level, and I think more occur during the dry than in the wet months.

It is the small and irregular obstructions on the ground which are the most likely to cause stumbling. A horse approaching a small saucer-shaped rut (Fig. 197) is more likely to blunder in crossing it than a wider and shallower one (Fig. 198). A horse that is careful will instinctively



Fig. 197.



Fig. 198.

shorten his stride at the trot to cross Fig. 198, but takes little notice of Fig. 197. A very small depression in an otherwise fairly regular ground may cause a horse to stumble, especially if there is a sharp rise (Fig. 199) at the opposite side.



Fig. 199.



Fig. 200.

A stone fixed in the ground (Fig. 200, *a*) is less likely to throw a horse down if trod on, than one loose on the surface (Fig. 200, *b*). But if the toe strikes against the fixed stone, the horse may certainly fall, though if it strikes the loose one it will have no effect.

Horses are more liable to blunder over small obstructions than large ones; this may be due to vision or to indifference.

The irregular surface at Fig. 201, which is a section of South African veldt, is more likely to cause a horse to stumble than if the place were covered with large loose boulders. In fact, it is astonishing when a horse gets on to this latter ground how admirably he conducts himself.



Fig. 201.

It is usual for a rider to say in explanation of his horse falling that the animal 'crossed its legs,' and for an owner to say that the rider 'threw the horse down'; in our experience both these statements are absurdities.

#### OVER-REACHING AND FORGING.

Horses which are short in the back, especially if they possess anything like hock action, are liable to 'over-reach.' So long as the injury is confined to the heel of the foot no serious harm arises, but when the back of the fetlock is struck, as it may be during a gallop, the flexor tendons may be cut, and severe, perhaps fatal, synovitis of the fetlock joint ensue.

The horse that inflicts this injury on himself is generally one that is known to 'forge.' Forging generally occurs at a trot, though it may happen at a walk. So long as forging is limited to the toe of the hind shoe striking the toe of the fore shoe no harm arises, though the noise is very irritating; but when the blow is inflicted on the soft parts of the heel, or back of the fetlock, as in the gallop, the injury may be very severe.

A horse that 'forges' cannot get the fore legs away quick enough. Some animals do it only when they are tired or in heavy ground, others will do it while they are still fresh and active.

The methods of prevention are to keep the hind shoes

well back under the feet, the use of a square toe and quarter clips, and rounding the toe of the shoe so as to leave no sharp edge to cut. These simple measures will generally prevent forging, but where in spite of them the heel gets cut, preventive measures in the fore foot must be adopted. The one we have found the most useful is to allow the heel of the fore foot to grow unduly high, the blow then instead of falling on the junction of the skin and hoof, falls below it on the hoof itself. In some cases a protective mechanism is required, but they are difficult to adjust and keep in their place.

For protection against speedy cutting a properly fitting boot which laces on the shank is necessary, with a portion carried up to protect the part. In fact with a little care in fitting and adjustment the rubber sole and heel of a canvas shoe make an excellent protection; the sole saves the shank from injury, while the heel takes the blows inflicted on the knee, but the greatest nicety is required in the fitting.

Boots may also be used for brushing, though one or two good rubber rings are probably most generally useful; in their absence the Yorkshire boot made of a piece of blanket is an excellent protection.

#### LAMENESS.

In the section dealing with Condition, we have gone with a certain amount of detail into the question of lameness, as it is impossible to separate the two.

Here we must consider other features of lameness and how it is produced, but always bearing in mind the importance of condition.

Irregular work, by which we mean relatively long periods of rest followed by work, is a common cause of lameness, not only because the animal is out of condition, but for the reason that long-continued rest is not an unmixed blessing.

Navicular disease may be produced by resting a horse in a stable and not allowing it to lie down. That such cases

occur among animals, which from disease or injury are kept in one position through their inability to lie down, we have repeatedly satisfied ourselves by post-mortem examination.\* There is such a thing as the navicular disease of rest, which is due to compression the result of long-continued enforced idleness; the only other factor required being a weak navicular bone with very little compact tissue.

There is also, of course, the navicular disease of work, especially if that work is sharp and irregular. The influence of long-continued rest in one position, in producing nutritive changes in the limb, cannot be too strongly impressed. We now refer particularly to the enforced rest which has to follow injury or disease, when the sound leg, as in a case of lameness, is frequently doing double work in supporting the weight of the body. Both flexor tendons and joints suffer, especially the fetlock joint and the navicular bursa. The laminae of the feet also suffer, so that even separation with descent of the pedal bone may occur.

Valuable as rest is in the treatment of lameness it should not be abused; if necessarily prolonged, the conditions we have pointed out should if possible be neutralized by the horse being placed in a box, so that he is at liberty to move about. The chief danger to be apprehended from rest is in those cases where it is taken in a fixed position, as for example in a case of broken knees. The hygienic advantage of slings is here demonstrated; if owing to the nature of the case it is impossible for a horse to be allowed to lie down, slings are indicated as a means of rest, and to assist in preventing permanent nutritive changes in the sound limb. What is true of the fore leg is equally true of the hind.

Nor does it require disease to produce these nutritive changes resulting from horses kept in one position; there is nothing commoner than laminitis from standing on

\* 'Some Joint Diseases of the Horse': *Journal of Comparative Pathology and Therapeutics*, vol. v., 1892.

board ship, and the exercise which is prescribed for horses at sea is directed against this condition. What is true for the horse at sea is equally true for the one ashore.

Severe work and prolonged rest may both result in the production of the same diseases of locomotion, but we must consider the former in a little more detail.

A horse even in condition cannot perform an unlimited amount of work. Valuable as condition is there is a limit to the protective influence it exerts; it cannot prevent a horse from getting tired. In a tired state of the body both tendons and joints may suffer, the latter become inflamed, resulting in conditions of joint disease peculiar to the horse, of which spavin and ringbone are good examples.

The causes of these inflammations are compression of the bones, and concussion, or sprain of the connecting ligaments. In the production of the latter, irregularities of ground must be taken into consideration. For example, the foot on a perfectly level surface bears evenly all over the wall, as may be seen by studying footprints. If the surface on which the foot is bearing is irregular, then the foot only bears on the most prominent part of the irregularity, so that a great deal of the bearing surface is lost; but, moreover, this irregularity causes a deviation from the vertical through the lateral movement at the coronet, pastern, and fetlock, and it is conceivable that in excess this lateral movement may lead to sprain of the lateral ligaments, especially with a tired horse.

We do not urge this cause as a prominent one in lameness, for there are certain joints like the hock where there is practically no lateral movement, and yet it is a frequent seat of lameness. Dissection reveals the fact that in the case of ringbone the ligamentous structures around the coronet are implicated, and that a great deal of the early enlargement of the coronets is ligamentous and not osseous. A very large coronet during life, leading one to believe in the existence of considerable bony deposits, may prove on dissection that the parts show little or no bony swelling, the enlargement being ligamentous. It is not

conceivable that ligamentous enlargement can occur in any other way than by sprains.

It is beyond the scope of this work to enter fully into the various causes of lameness ; we have dealt elsewhere\* with some forms of serious lameness, and the causes in operation. But it is essentially within the scope of hygiene to deal with their prevention, and the two chief preventive features are never to work horses hard that are out of condition, and never to work an animal beyond its strength. This latter includes the pace, the distance, and the weight carried or drawn. If attention to these preventive features were paid lameness would diminish.

Heredity as a cause of lameness is believed to play an important part, and considering the indiscriminate nature of horse breeding, it would not be surprising if it were so ; but as a matter of fact we believe the amount of exact evidence on this point is not very great, and the opinion of even experienced breeders is by no means above error. It is generally conceded that sidebone, ringbone, navicular disease, and spavin, are hereditary, and so long as men regard the final use of a crippled and worthless mare as something to get a foal out of, there is every reason to believe there may be a good deal of truth in the accepted theory.

Excepting navicular disease and laminitis we have made no special reference to foot lameness, though it is by far the most common cause of trouble. It will perhaps be more convenient to deal with it in speaking of the hygiene of the foot, as so many causes of foot lameness are mixed up with the shoeing question.

The next class of locomotor troubles produced by work are Fractures ; by far the majority of fractures are caused by kicks, but fractures from concussion may take place during work, of which the typical example are the suffraginis and corona. Both of these may be split or comminuted during a gallop over hard ground, of which a highway or

\* 'Some Diseases of the Joints of the Horse': *Journal of Comparative Pathology*, vol. v., 1892.

the wet sand of a seashore may be taken as examples. A sudden blow to the foot while the leg is off the ground may fracture the pastern. We have seen it occur from striking a hurdle in 'running out' from a jump, and from the foot striking the skirting board in the riding school during a jump. Fracture may also occur through a fall on slippery pavements. In these cases the legs are taken from under the animal, which falls heavily on its side, and frequently fractures the pelvis. Fractures of the first rib may also occur from falls on the breast caused by stumbling. Heavy weights like the wheel of a waggon passing over the coronet or foot may fracture the bones within, while the face may be fractured from injuries received while running away.

#### DISEASES DUE TO SPECIAL CALLINGS.

These are rather an interesting group of injuries or diseases due to the special work the animal is called upon to perform. Injuries frequent in one class of horse may be quite unknown in another.

*Race Horses* are very liable to sprains of the flexors and ligaments of the fore legs, to fracture of the pastern, to splints, and from their youth and severe work, to osteitis of the metacarpals. *Hunters* are liable to sprains, splints, spavins, foot lameness, curbs, thorns in the legs, exhaustion, lung trouble, and 'roaring.' *Saddle horses and Hacks* to much the same as the hunter, with broken knees, brushing, and speedy cutting added to the list. *Cab horses* sprains, spavins, ringbones, navicular disease, pneumonia and pleurisy, broken knees, bent legs, colic, and enteritis. *Bus horses* much the same as cab horses, with sidebones added. *Heavy draught horses* are liable to colic and chest trouble, quitters, canker, sprain of sub-carpal ligament, sidebones, ringbone, grease, mallenders, and sallenders. Those employed on railways suffer from shunting injuries, fractures of the ribs and pelvis, laceration and crushing of the feet, and even the entire internal foot pulled out of the horny case through the hoof getting fixed

in the points. *Farm horses* suffer from shoulder slip caused through one leg being in the furrow when ploughing; colic is also very prevalent, pneumonia and pleurisy rare; grease, thrush, and other diseases due to neglect are frequent.

*Army horses* suffer from saddle and collar galls, galls in the heels from the method by which they are tied up, fractures from kicks, laminitis from severe work on unconditioned bodies; every variety of lameness both of tendons, ligaments, and bones; pneumonia and pleurisy are moderately common, 'roaring' is prevalent; intestinal and stomach trouble frequent, but less so than in civil life, excepting where animals have been living in the open, and have taken up dirt and gravel with their food. If we take the army horse in India he is liable to unhealthy sores (bursattee), anthrax, *Filaria oculi*, surra, specific lymphangitis, capped elbow, colic and enteritis, ruptured stomach, and intestinal twists. In South Africa to bilious fever, 'Horse Sickness,' specific lymphangitis, lameness (especially laminitis), specific ophthalmia, and osteoporosis.

Ponies in hot dusty coal mines suffer from asthma and frequently broken wind; pneumonia is rare. Injuries or 'bumps' on the knees are very common, due to slipping on the sleepers during draught; in consequence of the enlargement of the knees many cannot lie down, and stumbling over sleepers becomes more common. Eyes get knocked out against projecting pieces of rock or coal; while the spine may be bruised and the poll lacerated from contact with the timber supporting the roof of the roadway. Miners' lung is practically unknown, though many spend their lives down the pit. The effect on the eyes of living some years in the dark is to cause a bleaching of the choroid (Woods.)\*

Horses that work in copper mines, or that graze in the vicinity of copper-smelting works, are liable to arsenical poisoning. Copper smoke contains 68% arsenious acid, and this may be inhaled, or more commonly taken in with the herbage. The effect on horses (and cattle) is to pro-

\* See p. 37.



duce ossific deposits on the knees and hocks, falling off of the hair, and general emaciation ; it is known locally as 'copper smoke disease.'

#### VICES OF WORKING HORSES.

*Panic.*—There is no animal more liable to panic than the horse ; when a large number are brought together, as in the army, it is extraordinary how easily they may be frightened, any unusual noise, such as men suddenly cheering, may provoke a stampede ; a thunderstorm is a common cause, but even a slight sound, such as a pistol shot or rifle fire, especially at night, may produce a catastrophe. Sometimes no cause for alarm can be assigned.

Whatever it may be, the effect on the mass is electrical ; so concerted is their action and their determination to break away, that it could not be more thoroughly carried out if a meeting had previously been held and a stampede determined on. The animals are quite unmanageable and apparently not responsible for their action ; they will run into obstructions the nature of which they are perfectly acquainted with, masses will try to pass through narrow openings, and in their state of fright they will even gallop into water, a thing no horse in his senses would ever attempt to do.

There are always one or more leaders who give the direction and the pace, and for some time the whole mass keep together ; finally they break up into groups, again under a leader, and will travel immense distances before fatigue compels them to slow down and eventually halt.

In the first mad rush they may do considerable damage to themselves and perhaps to the men ; they do not hesitate to gallop through tents and over men lying on the ground. Fractures of the limbs, spine, and skull are frequent ; wounds numerous, while as the result of galloping the pectoral muscles may be found so swollen, that the following day many are scarcely able to advance one leg in front of the other.

It is not possible to guard against stampedes; strange sights and noises, such as army horses usually never notice, and which it is part of their daily life to encounter, may quite suddenly be the means of frightening them.

Fear is rapidly communicated from one horse to another; it runs along a line like wildfire, and if at such a moment it is possible for the men to stand to their horses the situation may be saved.

Occasionally a stampede occurs while the men are with their horses, but as a rule it happens when the animals are by themselves, and generally at night, though we have known one take place in broad daylight.

It takes horses some time to forget a panic, and the recurrence of a stampede must always be borne in mind.

*Running Away.*—Closely connected with stampedes is ordinary running away, excepting that in this case an individual horse and not a body gets frightened and starts off.

In the first instance running away may be really due to fright either under saddle or in harness; some unusual noise or sight, or the breaking of something which leads to loss of control; but there are some horses that never forget their dash for liberty, and running away then becomes a vice, and a most dangerous one. Some animals will do it from freshness, others from nervousness and excitement. There are many nervous army horses that cannot stand the squeezing they get in the ranks, and shoot out as soon as a gallop or charge occurs. No bit will hold this class of horse, and like the 'stampeder' he will run into any obstruction. There are others that run away from lightness of heart, a consciousness of their strength, and the inability of the man to control them. It is a dangerous frame of mind for any animal to be in, and fortunately a rare one, for most horses regard man as their master and behave accordingly.

Running away under saddle is probably impossible to prevent, excepting by some arrangement for closing the nostrils; but a horse used for draught might have the

blinkers so arranged as to be capable of closely covering over both eyes, which with most animals would certainly suffice to control the vice.

*Jibbing* is a vice which in the first instance probably began through ignorance of what was required, and this being followed by punishment was resented. It never occurs excepting in an animal which is strong-minded, and has some ideas of his own on the question of labour. In all cases the horse recognises that he can be as firm as the man. He has begun to learn something of his own muscular and moral strength, against which that of a man is powerless.

If a horse makes up his mind not to work there is no force we know of which can make him. It is usual to regard 'jibbers' as stubborn, which no doubt they are, but we look upon it as a very high and extremely aggravating form of equine intelligence; while the horse that works until he drops, and exercises two horse-power when one quarter would suffice, shows the lowest degree of intelligence.

A 'jibber' in the very early stage may be cured by kindness and coaxing, but a confirmed jibber is incurable. A man with the best of tempers and extraordinary patience is required to overcome jibbing; encouragement is needed, never punishment, but as a rule it is a rather hopeless task. We have been told by Major Bostock, late A.V.D., that rocking the horse by catching hold of the shafts on either side will cure jibbing. The horse is simply rocked from side to side by each man pulling and pushing alternately, and after a time the animal gets so tired of the motion that he starts off of his own free will.

It is very important in order to prevent jibbing becoming confirmed, that any sore points on the shoulder or elsewhere from the harness should be attended to, and the parts thoroughly healed and free from tenderness before the horse is again tried.

*Shying*.—Shying may be a vice or due to a physical defect in vision. Though shying has been termed a vice,

yet in the large majority of cases it is not due to any inborn determination on the part of the animal to be alarmed at anything unusual, but is, in the majority of cases, an uncontrollable weakness due to a peculiar temperament.

As regards defects in vision these may be due to nutritive changes in the lens or to errors of refraction. Though cataract is generally believed to produce shying, yet the small circumscribed cataract so common in the horse does not affect the sharpness of the image on the retina. On the other hand, errors of refraction like myopia or astigmatism, especially the latter, will certainly cause a blurring of the image sufficient to produce shying. As we have shown,\* both myopia and astigmatism are common errors of refraction in the horse, though the amount is generally small.

The chief causes of shying among horses are due to (1) unusual objects, (2) common objects out of place. Among unusual or terrifying objects are traction-engines, motor-cars, motor-cabs and omnibuses, or electric trams. With reference to these latter, few horses shy at cabs, omnibuses or tramcars which are horsed, but when driven by a motor they are frequently an object of terror. In days gone by the bicycle was a cause of great alarm, but they have become far too common for any but a small majority of horses to take notice of them. In the East camels and elephants are most alarming to horses, and we have known the camel to be an object of alarm to an elephant. Few horses take any serious notice of trains, though there are very few outside big cities which can be trusted to pass under a bridge or viaduct with a train passing overhead.

Common objects out of place are by far the most frequent cause of shying. There are very few horses that would pass a truss of hay or straw lying in the middle of the road without shying at it, yet, if the animal possessed a shred

\* 'The Refractive Character of the Eyes of Horses': *Proceedings of the Royal Society*, vol. lv., 1894.

of reasoning power such an object should not prove alarming, for if he knows nothing else by sight he certainly knows hay and straw.

A tree in its ordinary position he takes no notice of, but a small branch lying in the road he may refuse to pass; the same with a heap of stones at the roadside, though he crosses them without a second's hesitation if they are laid on the road.

Shadows are alarming; an animal may pass day by day over the same piece of road in daylight, yet on a cloudy day or towards evening, he may hesitate and look from right to left for some object of alarm.

A still object is less alarming than a moving one, a piece of paper fluttering in the wind is more alarming than a sheet of paper that gives no sign of movement. The colour of an object also exercises an effect; black and white, perhaps from their distinctness, are more alarming than those which are coloured.

Impressions like wheel marks which run parallel with the road may not cause the slightest disturbance, while wheel marks running across the road at once attract attention in a horse given to shying. In the same way, though he may pass a stick lying in the axis of the road, there will be a difficulty in getting him past one lying transversely to the road.

Sometimes it is impossible to determine what a horse sees that frightens him. We have known an animal shy every day for months at one particular part of the road, though the only thing present was a small bush which he never hesitated to walk up to, and which presumably could not have been a cause of alarm.

Some horses may shy from freshness on first coming out of the stable, but this soon passes off, and cannot be included in the same category with the persistent 'shyer.'

Some will shy in the town and not in the country; some will shy persistently at one or two objects and no others. Taking all these facts into consideration, we are compelled to regard shying as more rarely due to defective vision

than any other cause. When shying is persistent from one side and not from the other, vision is probably at fault.

A horse that shies from nervousness never gets over it; with kindness and care in handling he improves, sometimes to such an extent that one is conscious he is passing an object he dislikes with an effort not to be alarmed; but complete recovery appears impossible, while in the majority of cases no improvement whatever occurs owing to the punishment, either actual or anticipated, which the horse associates with his vice.

No punishment will ever cure this condition, no dread of punishment will cause a horse to pass with an air of indifference any object he dislikes. Kindness, soothing, and encouragement, accompanied by firmness may do some good; horses are very quick to realize whether a man is on their back they can take advantage of.

The dangers of shying are often considerable; many a man has lost his life through a fluttering piece of newspaper being carried along the road, and many a collision or overturned trap has occurred from equally slight causes.

Though a horse that shies in harness is not under the same control as one under saddle, yet with attention to blinkers shying in harness can be greatly controlled. The blinkers should fit closely behind, and incline towards each other in front, so as to limit the area over which the horse can see.

#### HYGIENE OF THE FOOT.

The horse's foot is particularly liable to disease both from the delicacy of its mechanism, and also the injury to which it is naturally exposed.

The care of the feet should begin with the foal: in speaking of the young animal we dwelt on the importance of early handling as preparing the way to its final subjugation. No part of the handling process should receive more attention than the simple one of teaching the young animal to allow its feet to be picked up and attended to.

The attention the feet require at this time of life is to

keep them regular in length, and so avoid one side growing longer than the other, which tends to malformation of the limbs; they should also be kept clean and the foot pads regularly examined. While this is being done the feet may be handled as in shoeing, and the formality gone through of tapping the hoof with a hammer. Only those conversant with the shoeing of young animals can fully appreciate the value of these early lessons, which should be given once a week for a few minutes.

As the animal matures the foot becomes wider at the heels, and the foot pad better developed. The unshod foot of an animal brought up on a dry soil has a firm, well-developed foot pad, strong heels and bars. The latter in the foot of a wild horse we once had the opportunity of examining, were of extraordinary size and strength, very much stronger and deeper than is ever seen in the domesticated animal, thus adding enormously to the strength of the foot.

It would be interesting to know how much of the development of the bar of the foot in the domesticated horse has been lost in breeding. In a foot with large bars the sole is relatively smaller, so if by breeding we have increased the size of the sole and reduced the depth and size of the bars, it has been a change for the worse and not for the better.

Perhaps the two most common faults in the domesticated foot are a thin sole and weak wall. It may be these have been produced by want of care in breeding, but they are serious sources of trouble in working horses.

Probably the next most common fault is one of shape, the feet being broader than there is any necessity for, and on this point it is pretty certain breeding is responsible. Over a certain point what feet gain in width they lose in strength, as the wide foot has a weak sole and low heel.

Feet are no doubt affected by the character of the soil on which the animal is reared, damp soil favouring a wide spreading foot, dry soil a narrower upright foot. From every point of view the flat, low-heeled foot is objectionable and a source of weakness.

In the breeding of horses the question of the shape and strength of the foot should receive more attention.

The feet of the stabled horse bear eloquent testimony to the class of stable management which is in vogue. Cleanliness is an all-important feature; under the influence of manure and urine the horn of the foot is very liable to suffer, the urine acts chemically by its alkaline nature, in which horn is more or less soluble.

This corrosive action is particularly evident in the matter of the sole and foot pad, especially the latter, where in conjunction with wet and filth inflammatory trouble is set up in the sweat glands of the pad, with destruction of horn and loss of function.

The horn of the foot requires for its healthy condition to be kept in contact with the ground; the effect of pressure is remarkable, and especially is this seen in the foot pad; but any part of the foot will demonstrate the same thing. Take, for example, the unshod foot of a young animal, and observe how tough and close of grain the horn of the wall is, so hard, in fact, that this class of foot will frequently resist the passage of a nail through the wall.

Pressure also keeps the foot normal in shape and width; the parts are intended for contact with the ground and pressure, and if this pressure is not obtained the foot atrophies; this shrinkage, besides other effects, also means a loss of bearing surface.

Though the horn of the wall and that of the foot pad appear to the eye as totally different, yet as a matter of fact in structure they are practically identical, the difference in their consistence being a question of the amount of water in the horn fibres and intertubular structure. All horn requires moisture to maintain its elasticity; anything which interferes with the supply of this from the blood, or that causes its undue evaporation from the surface of the hoof, leads to a brittle condition of horn which is not compatible with a healthy foot.

Constant evaporation is occurring from the horn of the



foot, especially that of the sole and foot pad, and it is evident the amount lost by evaporation must be replaced if horn is to remain elastic; this is facilitated by the tubular character of horn.

Horn may exist in either an elastic form or else dry and brittle; the latter condition is well seen in the dried foot of the museum, that readily fractures like glass if dropped on the ground. A few hours soaking in water of this glass-like horn is sufficient to restore it to the condition it was in when first removed from the animal, while fracture of it from violence is now impossible.

Horn requires a sufficiency but not an excess of moisture; contact with the ground is also essential for the full development of the foot, and for producing the best class of horn; finally, it needs cleanliness, and especially freedom from urine.

Horn is only modified skin, and anything which affects the cutaneous surface may also affect the feet; this is very well seen in certain pathological processes, where sympathy between the skin and feet is very marked.

The care of the feet in the stable is comprised in the word cleanliness and ordinary dryness. Cleanliness to insure the horn undergoing no change as the result of the action of urine and fæces, ordinary dryness to avoid the rotting of horn by constant exposure to wet. We do not consider there is the slightest necessity for drying the feet after washing them out, as sometimes recommended. Since the days of Xenophon it has been known that horses kept on a dry surface had stronger and better feet, and feet more capable of resisting injury, than those brought up on filth and moisture.

If for no other reason than this, the abominable system pursued on the Continent of Europe, and at one time actually introduced for trial into our Army, of allowing horses to stand on unchanged litter for three or more months, stands unhesitatingly condemned. If horses' feet are poulticed in this way by standing on a fermenting mass of filth, while at the same time the horn is attacked by

the ammonia of the urine, there can only be one result so far as the foot is concerned.

The excessive wear of the foot which results from work necessitates some protection being afforded, and this is given by shoeing. There are other advantages from shoeing, such as saving concussion, but its chief object is to save undue wear and tear.

In the application of a shoe to the foot the functions of the various parts must be borne in mind, and though the function of a part is the field of physiology, it is permissible here to state the main features of the case.

A horse's weight is carried by the wall of the foot and that part of the sole adjacent to it, by the bars and foot pad. All of these parts in an unshod foot are in contact with the ground. The sole, being concave, would not rest upon the ground excepting in soft soil, nor is it intended to carry weight, excepting where it joins with the wall.

When a shoe is placed on the foot the natural condition just mentioned should as far as possible be complied with, the shoe should rest on the wall, adjacent circumference of the sole, and the bars. The foot pad should rest on the ground; it is one of the great anti-concussion mechanisms, and cannot perform this function unless on the ground. Further, if it does not rest on the ground, the pad becomes smaller, and the foot in consequence narrows.

The wall of the foot is strongest at the toe, and gradually gets thinner and thinner towards the heels; this is to allow of a certain amount of lateral play at the posterior part of the foot which occurs when the weight comes on the limb. From this it is evident that the toe and quarters of the foot are the only places where nails can with safety be driven, and that not only are the heels of the wall too weak to stand a nail, but such would interfere with the slight lateral movement known as expansion.

The wall of the foot at the toe forms a certain angle with the ground, and all the horn fibres, whether of sole, foot pad, or wall conform to this angle; any section of the wall

cut at this angle shows the wall to be the same thickness from above to below.

Owing to the shape of the hoof, the wall throughout its extent is of a different age; for instance, at the toe it is the oldest, and being the furthest removed from the coronet, is the driest and toughest; at the heel it is the shortest, youngest, and most elastic. The hardest and oldest horn exists where there is the greatest wear and tear, while the young and elastic horn exists where there is the most lateral movement.

The bars of the foot, being merely the wall turned in at the heels, are intended to support weight. The sole, on the other hand, is not a weight bearer; its arch becomes slightly flattened when the weight of the body comes on it. The foot pad cannot have too much weight placed on it, nor have too large a surface on the ground, if its anti-concussion mechanism is to be employed.

It is obvious that shoeing, to comply with physiological principles, should interfere as little as possible with the foot; the wall must be artificially reduced to a proper length, which varies slightly in different feet. The object of this reduction is to remove the overgrowth of the foot, the result of wearing a shoe. In carrying it out care must be taken that the wall is lowered evenly, one quarter must not be higher than the other, and one foot should be made the same length as its fellow; the heels of both feet should also be reduced to the same height.

The shoe should then be fitted to the outline of the foot. It must bear evenly all over the wall and bars, and the crust should be so lowered that when the shoe is in its place the foot pad is level with the ground surface of the shoe and so supporting the horse's weight.

Clips are necessary to prevent shoes driving back under the feet; they should only be lightly hammered into their position. Clips tightly driven down are said to produce 'seedy toe.'

No more nails should be used than are absolutely necessary the number depends on the size of the shoe. Four

may be sufficient for a light fore shoe, six or seven for a heavy shoe. In the hind shoes, the strain being greater, it is always customary to place more nails than in the fore.

Both high and low nailing are damaging to the feet. In low nailing an insufficient hold is taken, the shoe gets cast, and the wall breaks away. In high nailing the nail-holes remain too long in the wall, as it takes some weeks for them to grow out. Wherever a nail is driven in the wall the portion of horn external to it becomes brittle, so that high nailing induces a brittle wall.

Nails should not be too large, but selected according to the size of the shoe. Large nails in small feet are very destructive and not always free from danger. The direction taken by the nails is important; at the toe they can slope and take the same angle as the wall fibres, but at the heel they must be more upright so as to avoid running the risk of injury in the thin wall. Clenches must be slightly bedded in and hammered down.

The chief evils caused in shoeing are produced by the knife and rasp. With the former the sole is thinned out, sometimes until it springs under the thumb. This in days gone by was supposed to facilitate the hoof mechanism, but as the function of the sole is the protection of the sensitive sole within, it is obvious it cannot be too thick or strong for this purpose. The exfoliated sole can be pulled out at each shoeing, but a knife should never touch it.

The bars are frequently thinned or cut away under the impression that by so doing more spring is given to the foot!

The foot pad which forms one of the chief anti-concussion mechanisms is invariably pared away, under the extraordinary misconception that it is a dangerous excrescence, and cannot be too effectually removed!

It is inconceivable that any rational person looking at the horse's foot could ever hold these ideas, yet they are universal outside the veterinary profession. It would be quite as reasonable for the hard skin on the weight-bearing

parts of the human foot to be thinned until the sensitive parts beneath were exposed.

When the foot pad is cut away the heels contract, the pad shrivels up and is thrown out of use, the cleft becomes diseased, and the whole foot in a bad case becomes narrower.

A practice in shoeing known as 'opening the heels' is carried out with the knife, a wedge-shaped piece of horn being cut out of the junction between the bar and foot pad. It is as senseless as it is harmful.

It is a remarkable fact that the three structures in the hoof which protect the sensitive parts within or ward off concussion, should be stripped of their obvious functions by these insane mutilations.

The other mutilations which are inflicted on the foot are perpetrated on the wall by means of the rasp. Frequently in indifferent shoeing the shoe does not take the outline of the crust, and after being nailed on the projecting portion of the wall is rasped away to agree with the outline of the shoe. When the function of the wall is borne in mind, it is obvious that this reduction of the weight-bearing surface is wholly indefensible. There are very few horses turned out from a forge that have not had the whole of the wall rasped from the coronet to the ground surface to improve its appearance! As a matter of fact this is one cause of brittle feet, by allowing increased evaporation of water from the torn surface of thousands of horn tubes.

No mention has up to the present been made as to the pattern of shoe, for the reason that there is nothing in patterns. A light horse should be shod with a light shoe, a heavy horse with a heavy shoe. The weight is merely a question of wear and tear, and the undesirability of shoeing too frequently. Provided a shoe admits of the principles above laid down being complied with, its pattern is an unimportant matter, which can be left to the fancy of the farrier or the taste of the owner. The only exceptions we can make to this statement are that most riding horses, or others intended for trotting work, go better in a shoe turned

up at the toe, so as to imitate as nearly as possible the wear which occurs at the toe of the unshod foot. Most animals working over stony ground require a shoe wider in the 'web' than those working on a level and good surface. Finally, shoes made so that the web narrows at the heels are a most prolific cause of corn, and should never be used.

Many horses which go 'feelingly' on macadam or other hard roads, have their action improved by wearing a heavier shoe than they need ordinarily carry. Light shoes, like tips, admirably suited for working off roads or on soft ground, soon cause a horse to lose his action if he is worked over a metalled or other hard surface.

No special mention has been made of hind shoes. The care in fitting and the care of the feet is the same as in the fore feet.

*Frost Shoeing.*—There are various methods employed in 'roughing' horses to enable them to move during frost, the most common being drawing out the heels of the shoe in the fire and turning them up. This rough-and-ready method is destructive to the feet, and frequently leads to accidents, owing to the haste which occurs where a large number of horses have to be 'roughed.' As a rule the turning up of the heels, as it is termed, is generally sufficient for the short frosts experienced in this country, but during a prolonged frost the method is unsuitable, as the process cannot be repeated without seriously shortening the shoe.

A simple and, with care, good method is the use of frost nails, which are placed in the heels of the shoes in a hole previously stamped in anticipation at the last shoeing. The shoe is fitted sufficiently wide at the heels to allow the nail to come out, and it is then turned under the shoe for safety, or cut off within a quarter of an inch of where it makes its exit, and the short clench then hammered down. This method possesses very many advantages, as no skilled labour is required, but it also has its weak points. The holes must be stamped in the shoe of the exact size, or the nail 'wobbles' and gets drawn out; the system is of no use in a shoe worn at the heels, as it does not afford sufficient

socket for the neck of the nail. The hole must be thoroughly cleaned before the nail is inserted—no easy matter when tightly packed with gravel—and a process of back-pritchelling is frequently required to drive out the gravel plug. If the inside nail rises it will probably injure the opposite leg, especially if the horse 'goes close.'

Undoubtedly the best, though most expensive, method is by means of screw cogs, the heels of the shoe being previously 'tapped,' while the thread is protected either by wearing a 'blank' or by a piece of cork carefully inserted. If the 'blanks' get worn they are difficult to remove; if the corks are not carefully inserted dirt gets in and refuses to allow the cog to be put in its place. Unless well screwed home the cogs work loose and get lost; if the cog is very hard it may break off close to the shoe, and the thread left behind is most difficult to remove.

In fact, there is no method known to us which is without its objections; perhaps the nail is the simplest for ordinary use, and certainly the least expensive.

Whatever method is adopted the inside 'sharp' of each foot is liable to damage the opposite coronet, especially when the animal is turning, and wounds of the coronet from this cause may produce deep-seated mischief. In order to prevent this accident the inside sharp is placed with its chisel head in the length of the shoe instead of across it. Where sharp-pointed studs are used this precaution is not possible, but a blunt cog is sometimes placed in the inside heel, of corresponding height to the sharp cog in the outside.

*Brushing.*—In the section dealing with work, mention was made of brushing and other forms of interference.

The prevention of brushing may be considered an hygienic necessity, though it cannot be dealt with in detail.

The causes of brushing with horses not possessing malformed limbs, are overwork and shoes fitted too full. Horses brush when they get tired in spite of well shaped limbs. Brushing from malformation is the most frequent and difficult to deal with.

An animal that brushes from excessive work requires protection to the damaged fetlock, but no alteration of the shoe; time, a reduction in work, and good feeding are all that are needed. But for malformations special shoes have to be devised, and the principle in all of them are much the same, viz., to keep the shoe well inside the foot, and to raise the inner side of it so as to throw the foot outwards. In effecting this, numerous patterns have been adopted, for which special reference must be made to works on shoeing.

The class of shoe suitable for a horse that hits his fetlocks is suitable, with such modification as the case demands, for one that 'speedy cuts'; but in all cases not only should the shoes be altered, but protection to the limbs worn.

There are certain peculiarities about some feet which require notice.

Brittle feet are very common in hot climates, due to standing on hot ground, and the constant evaporation occurring from the surface of the wall. There are some horses which are constitutionally disposed to brittle feet, evidently due to an abnormal reduction in the amount of water in the horn.

Feet that grow slowly are frequently associated with a brittle condition: most horses grow at least half an inch of horn in a month, and some very much more. The feet now under consideration show little or no growth, so that the wall becomes in time riddled with nail holes, and if, as frequently happens, a portion of the crust comes entirely away, there is nothing left to nail to.

Both brittle and slowly growing feet are improved by the walls being kept wet, and by greasy applications to the feet. These, of course, do not help the growth of horn, but assist to render it less brittle, and prevent evaporation from the surface.

On both brittle and slowly growing feet shoes should be kept on as long as possible without being touched. If such horses can go six weeks without shoeing so much the



better, for it means less interference with the feet. In order to make the shoes for such cases last a long time, they may be of steel, or steeled at the wearing points. The principle involved is that it is better to shoe a horse with slowly growing or brittle feet six times a year rather than twelve; in the meantime by wet applications to the wall of the foot and ointments, to prevent evaporation and try and keep the horn in a natural condition, but such feet are always a trouble and unsatisfactory.

In the same way that some horses grow very little wall others grow but little sole, and here the risk of lameness becomes considerable; fortunately by artificial means the sole can be protected and strengthened, but such feet are very troublesome. A horse with thin soles may be shod with leather, and the space between the leather and sole filled in with Stockholm tar and tow; in some cases it is sufficient to increase the width of web of the shoe so as to afford more protection to the sole, and such shoes must always be 'seated.'

Flat feet are very common among the heavier breeds of horses; they should be protected by shoes wide in the web.

*Diseases arising from Bad Shoving.*—We have alluded to the injuries that occur from shoes being fitted too full; accidents also occur from clenches being allowed to project; lameness results from shoes bearing on the soles, especially a flat sole. Brittleness of the wall follows rasping of its surface; contraction of the foot results from cutting away the foot pad or not giving it ground pressure. Inflammation of the sensitive pad (thrush) arises from the absence of ground pressure, and the presence of dirt and filth, especially from the stable flooring.

Bruising of the sole or deep structure of the foot follows paring out of the sole; weakening of the heels results from paring away the bars; seedy toe in some cases from clips being hammered down too tightly. Corns occur from the heel of the shoe pressing into the angle formed by the incurving of the bar, and this is brought about either by

shoes being put on too short or left on too long. Narrow heeled shoes are also a prolific cause of corn. Weak dry walls frequently fracture under the strain of work, constituting a sand crack.

Injury may occur to the feet as the result of the shoes being fitted too hot. This is only likely to happen in a horse with an abnormally thin sole, or one where the sole has been pared out 'until it springs under the pressure of the thumb.'

Injury from nails being driven too close is probably the least frequent accident in shoeing. It is an annoying occurrence, but if the man is sober it should be treated as such. In fact, we doubt whether any other mechanic could drive thousands of nails every year through a structure from one quarter to half an inch in thickness, and have such immunity from accident. It increases our respect for the mechanical skill of the farrier, when we bear in mind it is only by sound that he knows whether the nail is taking the right direction or not.

*Diseases arising from Neglect.*—Clean stable floors and cleanliness of the feet are most important factors in keeping the feet healthy, especially the pad and the sole. The hind feet are the most liable to be affected with thrush, and they are more exposed to the action of urine and fæces, and further owing to the prevalence of 'calkins' or thickened heels ground pressure is seldom given.

Horses left standing on filthy litter, puddles of urine or feet balled up with fæces, foul moss litter or other absorbent bedding very soon contract disease of the foot pad, and the soles become cheesy and crumble away. Cleanliness of stable floors is a hygienic necessity; if the above conditions become aggravated even canker may appear.

*Injuries arising from Work.*—Injuries which occur to the feet at work are due generally to picked up nails or stones. The former may be extremely dangerous and have ruined many a horse. Their serious nature depends upon where they enter; an inch or so from the point of the

foot pad is a common place and the most dangerous, as the navicular bursa is very liable to be punctured.

Animals employed in building operations, especially where wooden huts are concerned as in military camps, are very liable to suffer from picked up nails. To prevent this, we have been compelled to have all animals engaged in building operations shod with an iron plate under the shoe, and secured like a leather sole. It is made of ordinary galvanized iron.

The worst kind of nail a horse can 'pick up' is the type used by 'slaters,' the next worst is the French nail. The mechanism by which a horse picks up a nail is by no means clear. Of the many nails one sees lying about practically none are ever found standing on their heads point upwards, yet in some way we are not prepared to explain, the nail gets tilted point upwards and penetrates the foot. It rarely penetrates the sole, nearly always the pad, and unfortunately selects that part which covers the most vital portion of the foot.

#### SADDLES, HARNESS, AND DRAUGHT.

The injuries which saddles and harness, especially the former, are capable of inflicting, are more prominently brought to notice in military than in civil life, owing to the special conditions under which animals have to work on a campaign.

As a source of animal loss in war sore backs occupy a very important position, not only from the actual amount of inefficiency caused, but from the serious effect they may have on military operations. About one quarter of the total inefficiency and loss on service is due to injuries of this class.

There are of course special reasons and causes for saddlery and harness injuries assuming such serious proportions during war, and these causes we shall presently have to study; but whether seen in war or peace, the injuries are identical in nature though not in severity, and

produced by one or other of the definite causes to be referred to.

The structures implicated in these injuries are skin, muscle, and bone, and we shall first inquire what there is in these which causes them to become affected from either saddle or harness injuries.

*Cause of Injury.*—This brings us to a consideration of the actual exciting agents which are at work, and though the list of causes we have to mention is numerous, yet all injuries, slight or severe, and no matter what part of the body they affect, are due to two causes :

1. Friction.
2. Pressure.

If friction be applied to a portion of skin, in a short time the hair is rubbed off and the part becomes covered with a dew of serum, showing that the epithelium has been removed to a sufficient depth to expose the lymph channels.

If the rubbing be kept on long enough, it will be quite possible to gradually wear a hole in the skin, and expose the tissues beneath ; but it will take longer to wear a hole in the dermis by friction than it will to remove the epidermis.

The animal most out of condition is the one in which the skin earliest shows the effect of friction, while the animal in the hardest condition is the most resistant. And this holds good for other animals than the horse ; the man trained for a fight is most difficult to bruise or graze. The influence of condition in the prevention of skin injuries, was alluded to in dealing with this subject in an earlier section. In the prevention of injuries by saddles or harness, 'condition' is of supreme importance ; the most perfectly fitting material will rub an animal that is 'soft,' and this is particularly true of such parts as lie beneath the collar or under the girth, places where considerable movement occurs.

Pressure acts differently ; it produces injury to the skin by depriving it of its capillary blood-supply, and the amount

of pressure necessary for this is extremely small, as may be demonstrated on the back of the hand; the white mark left as the result of very slight pressure is a bloodless area.

Pressure is capable of killing and cutting through any of the tissues of the body; limbs may be amputated by this means, even the bones cut through. If bone cannot resist pressure, it is easy to understand why skin and muscle suffer.

In the pressure which produces sore backs both skin, muscle, and bone suffer; so long as there is a layer of muscle between the skin and the bone, the pressure required to kill skin, has to be exercised for a longer time than that needed to destroy skin where the bone alone is directly beneath, for the muscle acts as an elastic cushion. In those parts of the back, as on the withers and spine, where the skin has the bony framework immediately beneath, both the skin and skeleton may in a very short time suffer to a considerable extent, while where muscle lies between the two, as over the ribs, the time occupied in destroying the skin is greater.

No living tissues can withstand continuous pressure, even when it is maintained by a relatively soft and elastic substance. It can, therefore, be readily understood the harm that speedily arises when the pressure is brought about by a mechanism of wood and iron, such as a saddle-tree, and the whole forced into the back by the weight of the rider. Just as in friction, an animal in hard condition is better able to withstand pressure than an animal out of condition.

No matter where the injury occurs, or how it is brought about, friction or pressure, or both combined, are the two exciting causes, and are accountable for all the disorganization produced.

The above simple and very obvious statement is full of interest to us, as it explains the many injuries inflicted by saddles or harness.

So far as we have gone the remarks apply equally to

saddle or harness injuries, it is now desirable to specialize, and in the first place to deal with,

#### SADDLE INJURIES.

In order to form a correct appreciation of these it is necessary to glance at the structure and function of the back, without trenching too far on the field of anatomy and physiology.

A horse is not built for carrying weight; a horizontal spine is necessarily imperfect in this respect compared with the vertical spine of man. Moreover, some of the bones of a man's spine are not only relatively but actually larger in their body than those of the horse. A man is capable of carrying a weight which would crush a horse; further he can carry a weight, which he cannot possibly lift, by adjusting it over his vertical spine.

The horse, on the other hand, is adapted for dragging a weight, which man is not, as the weight of a man's body is small compared with his strength; further the body cannot be thrown far beyond the fulcrum at the feet, for which reason it is unable to exercise the force which is necessary for traction.

We have previously dealt with the weight a horse should carry, and in connection with this, his weak horizontal spine should be remembered as the chief cause of his defective weight-carrying power.

*Shape of Backs.*—All backs are not of the same shape, there are some naturally weak (hollow backs), others extremely strong (roach backs), and between these two extreme conditions any variety may be met with. Some are long and weak, others short and strong; some with high razor-like withers, others with thick low withers; some are wide, others narrow; the muscles on some backs stand up full and firm, on others they are small, ill-developed and soft.

We need not be surprised at these differences; horses' backs vary in make, shape, size, and condition, as much as

any other part of the body, and it is desirable this should be borne in mind, as alteration in saddles suitable for some are quite unsuitable for others.

The weakest form of back a horse can have is one which is hollow. Such formation of spine is associated with a very high razor-like wither, and animals of this shape are very easy to ride; but for carrying weight they are useless, while it is the back most liable of all others to injury.

The next objectionable shape is one that is long, not only in the back but also the loins; length means loss of weight-carrying power, and in such backs the muscles are small and ill developed, and the back is narrow in its transverse diameter.

The best back is a short one, not so short as to give insufficient room for the saddle: the shortness must be in the loins; the shorter the loin the wider it becomes, and width of loin means short, plump, well-developed muscles and implies carrying power.

All backs must have width; their width is due to rib curvature; if the ribs are straight instead of being curved there is nothing for the saddle to rest on. The saddle rests on the ribs from the 8th to 17th, and the curvature of rib now being described is least at the 8th and greatest at the 17th. A horse is narrower in front than behind, great width of chest for a saddle horse is undesirable, for it means loss of speed, but sufficient width is essential. It is on the curvature of the last nine ribs that the saddle rests; it should never rest on any part of the spine, nor on the loins.

Figs. 202 and 203 show a vertical section through the 8th and 17th bones of the dorsal vertebræ; the dotted lines show where the pannels of the saddle should rest.

It is obvious from what has been said that the make and shape of a back greatly influences the production of injury; it is just as important for a saddle horse that the back should be of good shape, as that the limbs should be.

It is perfectly impossible for the spinous processes of the vertebræ to carry weight no matter how slight; the pressure

of a strap or buckle, let alone the pressure of a saddle, is sufficient to set up considerable injury; this is the reason why projecting spinous processes, as in high withers, are so objectionable. Conversely, the low thick wither is objectionable, for apart from the fact that with such a conformation it is most difficult to retain the saddle in its place, there is also the fact that by being thick they are liable to be pinched, and spinous processes are just as intolerant of pinching as they are of pressure from above.

*Movements of the Scapula.*—The next point in the structure of the back that must be glanced at is the

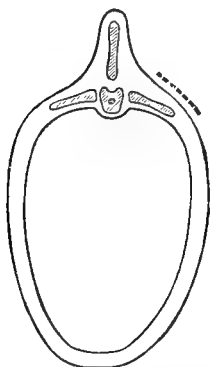

Fig. 202.—Section through the 8th Bone of the Back. The dotted line shows the position and direction of the pannel.

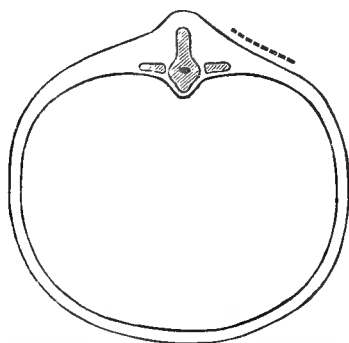

Fig. 203.--Section through the 17th Bone of the Back. The dotted line shows the position and direction of the pannel.

scapula. The anterior part of the body is slung between the fore legs; every movement of the limbs necessitates a movement of the scapula, and the movements of the upper end of this bone are such as would be produced were it pivoted to the vertebræ at its upper part. When the neck of the scapula advances, the supero-anterior angle of the scapula performs an upward and backward movement, while the infero-posterior angle is depressed forwards and downwards. These movements occur at the moment the leg is advanced and the foot placed on the ground. While the body is passing over the foot, a reverse movement of



the scapula occurs, the anterior angle passing downwards and forwards, the posterior upwards and backwards, until the body has completed its passage over the limbs; a final movement of the scapula occurs at the moment of propulsion, the whole of the posterior angle with its attendant muscle appearing to be pulled outwards from off the ribs, so that the part bulges in the most marked manner.

It is owing to these movements that we insisted in the section dealing with stumbling that scapula pressure was a cause not to be lost sight of, especially where small horses and big saddles are employed. The scapula both for the safety of horse and man must have its full range of motion unimpeded; it is hard enough for a horse to carry weight on his back, but it is intolerable that he should carry it on his scapulæ.

In the army, where longer and heavier saddles are used, this question of scapula pressure is of the utmost moment, for it is obvious, quite apart from the risk of stumbling, how easily horses may tire from this cause. It can readily be shown that the fore legs of the horse carry more than half the weight of his body, and the weight they have to carry is naturally increased by placing a man on the back. The position of the rider also influences the weight carried by the fore legs; it is increased when he leans forward, and decreased by leaning back.

The influence of this on scapula pressure is very obvious, but is intensified by bearing in mind that the function of the fore limbs is to propel the body. The mechanical disadvantage which the features we have been considering create need no further insistence.

*Where the Weight should be Carried.*—We have stated, that the weight carried on the back is not borne by the spine but on the ribs. These have a flat upper surface, gradually increasing in width from the 8th to the 17th rib, on which the weight is borne. The loins, on the other hand, are not weight bearers, their function is concerned chiefly in locomotion, and if pressure be placed on them they suffer in consequence. There is a rolling or lateral motion in

the loins during progression, which can be perfectly felt by placing a hand behind the saddle, and if weight rests here, the friction produced by the rolling movement of the loins very soon produces injury.

Though we have said the weight is carried on the ribs, yet, of course, it is necessary for the ribs to possess a sufficient covering of muscle.

Where the muscular development of the back is small and the ribs easily felt through the skin, we know for certain such a horse cannot carry weight for long without an injury resulting. In fact, the muscular development of the back is everything; as it increases or decreases in amount so the back alters in shape, and every alteration in shape means an alteration in the bearing surface of the saddle. As the muscles waste a gutter forms on either side of the spine, and the processes of the vertebræ project in an ominous manner. As the muscles develop the gutter disappears, and eventually the processes of the spine are lost to view.

It is owing to muscle waste that sore backs are so largely produced, as the exciting causes (pressure and friction previously alluded to) have so much more scope for action on the skin and framework, when once the natural clothing of the skeleton begins to waste away. It is this muscle waste which in army animals has to be replaced artificially if backs are to be kept free from injury. In connection with this it is of the utmost importance to bear in mind, that when the general vitality of the body is lowered by exhaustion and muscle waste, this loss of resistance extends to the skin, which then becomes far more susceptible to pressure and friction.

We do not intend here to deal with military saddles—that question is fully dealt with elsewhere\*—but the principles of fitting deduced from the foregoing are very obvious, and apply to any saddle either in civil or military life.

*Fitting a Saddle.*—In fitting a saddle we should see that

\* 'Saddle and Sore Backs': War Office Publication.

it is high enough above the spine, and wide enough in the front arch to admit the withers both in their height and width. A saddle not wide or high enough in the front arch should at once be rejected. In fitting a saddle it is not sufficient to simply place it on the back and look at the parts mentioned, the girths must be drawn and a man put in the saddle. An arch which appears quite high enough before this procedure, may now be found to touch the wither or to pinch it.

With a man in the saddle, leaning forward so as to increase the severity of the test, two fingers should easily be able to find admission between the arch and the withers, and the same should be able to gain admission behind, between the upper part of the spine and the underneath part of the rear arch.

If it is a new saddle which is being fitted, it is important to remember the stuffing in a new pannel soon settles down under pressure, and parts which were previously out of harm's way are now brought dangerously close to the saddle-tree.

Plain saddles are so cut in front that there is seldom any chance of scapula pressure being caused; but should a horse be very prominent at this part, and the saddle cut straight, the blade-bone will be interfered with, and a saddle more cut back will be required.

The fitting of a man's saddle is simplicity itself (we refer here to civil and not military saddles), but that for a woman is far different. The tendency of their saddles is to heel over to the near side, with the result that they are responsible for more wither injuries than men. Further, though bad riding is frequently and ignorantly urged as the cause of sore backs with men's horses, with women it is by far the most frequent cause. If a woman fails to sit upright, so that her saddle no longer remains in the middle of the horse's back, she will give the animal a wither injury; further, she will damage every horse she sits on until she does learn to sit with her weight balanced in the centre. Very little attention by the rider is required to

insure this, if she sees the off side of the saddle pressing against the withers, she should know at once that her weight is not properly adjusted.

Side saddles are most troublesome to fit, but the principle to adopt is that if the woman cannot sit up straight, increase the stuffing in the near side of the saddle so as to give it a cant to the off side, while a 'chamber' may be made in the pannel opposite to the injured wither, so as to keep it off the part; but the matter lies more with the horsewoman than the saddler.

*Chambering Saddles.*—A 'chamber' just alluded to is made by pressing the hair out of the pannel opposite to the injury, stitching it so as to keep the stuffing out, and so make a concavity over the wound and take the pressure off. A chamber must be in the exact spot required, which sounds rather a truism; unless there is blood on the pannel to guide the saddler, it is most likely he will put the chamber at some spot where it is not required.

The way to mark the site for a chamber is to make a mixture of a little lamp-black and vaseline, touch the place requiring protection, then put the saddle on. The black mark on the lining is an infallible guide as to the required position. A chamber should always be larger than the part it is desired to protect.

For sanitary reasons the lining of a saddle should never come in contact with the skin, there should always be something between the two, in order to prevent the sweat getting into the stuffing. A carefully dressed piece of leather answers very well, but preferably an absorbent surface like felt, which is both soft, porous, and easily cleaned.

As far as possible there should be a current of air along the spine; the object of this is not to keep the back cool, but to insure the existence of a channel above the spine.

*Girth galls* are very common in horses out of condition, and those whose saddles work forward owing to the thickness of the shoulders. Where condition is at fault the matter is easily rectified, time and exercise will give the

needful immunity. A change of girth to something softer may also be tried, a string or hide girth gains a better grip on the skin than the ordinary web girth, and so produces less friction.

For keeping the saddle in its place with a thick shouldered or a big-barrelled horse, the arrangement used in the army, described in the work previously mentioned, may be used ; it is unsightly for a private horse, but the man who rides a horse that ought to wear a collar may not consider this any objection.

*Stuffing Saddles.*—The only stuffing for pannels worth any consideration is curled horsehair ; this is elastic, and has a spring that nothing else can give. In course of time the stuffing settles down and takes the impression of the horse's back. This should never be unnecessarily disturbed ; it means the weight is evenly distributed, and such pannels may be in use a very long time before the stuffing becomes so compressed as to bring the tree too near the back.

There are many other pannels which could be worn, for instance felt, but the most generally useful is horsehair. We have known pneumatic pannels tried, but there appeared to be a prejudice against them. They are ideal in theory, and some day little else may be seen.

## HARNESS.

*Collars.*—We have previously studied the movements of the shoulders during progression and described their backward and forward motion. It is this movement which influences the fit of a collar and the injury produced. In a state of rest the collar is bearing on two parallel surfaces, viz., both shoulders ; during movement it is resting on an oblique surface as one scapula is passing backwards while the other is going forwards. It is this movement which causes so much oscillation in a collar, and it is this lateral movement which is largely responsible for collar injuries.

There is a class of shoulder suited for draught, viz., one that is upright, and that affords above the shoulder joints a good wide bearing surface for the collar to rest on. Such shoulders are thick at the root of the neck, while the withers are low and broad. In fact, the most suitably shaped surface for a collar to rest on, is exactly the opposite to that required by a riding horse.

Fine oblique shoulders are most unsuited for draught, as they afford very little bearing surface, and the tendency of such a collar is to rise on the shoulders. All collars rise on the shoulders immediately weight is put into them, but this rising is aggravated in an animal with fine sloping shoulders.

Necks and shoulders vary very much in shape. A moderately thick neck in front of the withers, with plenty of muscle on the sides of the neck and clothing the front of the blade-bone, are the best structural conditions for draught. Thin necks, such as may almost be felt through from side to side, show a want of stamina and defective strength.

In dealing with injuries due to saddlery, we divided the causes into two groups—friction and pressure. While pressure holds the palm in the production of saddle injuries, friction is the chief cause of collar trouble.

*Fitting a Collar.*—The secret in fitting a collar is to get it to fit closely in order to reduce the friction. Its inner edge must lie close against the side of the neck, but no effort must be required to press it on to the shoulders, or it indicates it is too narrow. Between the inside of the body of the collar and the neck, the flat of the fingers should find admission from top to bottom. More than this allows of too much lateral play and produces chafing.

The collar should rest evenly on the shoulders from top to bottom. To judge of this, both sides of it should be taken hold of and the collar pressed into its place. In doing this, there should be no see-saw motion, which would indicate that only the centre of the body of the collar was bearing on the shoulders.

The crest of the neck must not be pinched. The inside of the top of the collar should correspond to the thick crest of the cart horse; some collars meet too closely at this part to admit a thick crest without pinching. The hand should be able to find admission between the crest of the neck and the collar.

The depth of the collar is important; it must be deep enough to prevent pressure on the vessels at the root of the neck and trachea, it must also be deep enough to permit the slight rise in the collar which occurs when the horse puts his weight into it. But a collar which is too deep—viz., one which admits of the whole arm being introduced—is a very serious evil. If the collar will admit the hand and wrist being inserted between the throat of the collar and the front of the neck, it is sufficient for all purposes.

The 'after-wale' of a collar is the piece of thick leather which covers the outside of the body. In fitting a collar, especially a new one, particular attention must be paid to the position of the edge of the after-wale. Sometimes it touches the skin when the horse places his weight into the collar, and is then capable of producing considerable injury.

The projecting rim which runs around the front part of the collar is known as the 'fore-wale,' and in the space between the fore- and after-wale the hames are placed. The hames must take the shape of the collar: a collar that fits perfectly without hames may prove too tight when the hames are put on. In such a case they are too straight. In fitting the hames attention should be paid to the position of the trace attachment; it should neither be too high nor too low. The hames considerably increase the rigidity of a collar. The collar should be as light as consistent with the nature of the work; all unnecessary ornamentation and heavy housings should be abolished in order to reduce weight.

The collar should lie on the neck without pinching, and especially attention should be paid to this in pole draught,

as the greater part of the strain in 'pulling up' is thrown on the neck, which may get pinched or sore from pressure. In a collar well fitted it should be possible to introduce the hand beneath the collar and the neck.

A new collar even when it fits is a possible source of injury, for a collar has to be made by wear to take the impression of the shoulders, falling into depressions and accommodating elevations, and it is only after one has been in use for some time that it really fits. In this respect a new collar is worse than a new saddle.

From this it is obvious that a collar which fits a horse when in good condition does not fit when he loses condition, and under these circumstances some alteration must be made. The one which commonly suggests itself is putting more stuffing in the collar, or to speak correctly 're-plugging' it; but this means when the horse regains condition the collar is too tight and the extra plugging must be removed. The best method of alteration under these circumstances is a false collar, composed of a felt lining secured to the body of the collar by stitches; this can be removed when the animal puts up flesh. By means of felt any required number of pieces can be introduced, and practically any alteration of a large collar effected.

Collars are sometimes 'chambered' the same as a saddle pannel, but it is as a rule very unsatisfactory and we do not recommend it. Pads placed under collars to keep them off a damaged surface are equally unsatisfactory, for the draught comes where the pad rests and produces further injury. It is far better to throw the animal out of work for a few days, and in the meantime fit the collar.

The stuffing of a collar consists of rye straw; in course of time this settles down, and the lining gets worn, the collar must then be 're-plugged' and relined.

The injuries produced by collars are represented in the diagram (Fig. 204).

No. 1 is a common injury generally due to the strain in pole draught pulling the collar down on the neck. It can



be prevented by fitting the collar closer to the sides of the neck on the region lying between Nos. 1 and 2 in the diagram, and taking all the bearing off the crest.

The injury at No. 2 is due to a collar being too tight, and its remedy is obvious, viz., some of the plugging must be removed.

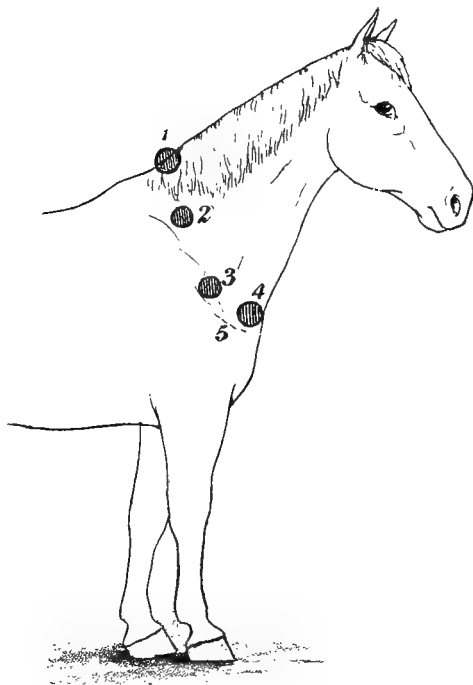

Fig. 204.—The Position of Collar Injuries. 1, Collar gall due to pole draught and collar resting on the neck; 2, collar gall due to a tight collar; 3, collar gall due to collar being too wide; 4, collar gall due to collar being too wide; 5, the dotted line shows the position of 'after-wale' injuries.

Injuries Nos. 3 and 4 are due to a wide collar producing friction; the remedy is to reduce the width by means of strips of felt, or increase the plugging at the part.

At No. 5 the dotted line indicates where the edge of the after-wale cuts into the skin, when the stuffing in a collar begins to settle down.

In seeing a collar on to determine the cause of injury, it

should always be raised on the neck in the position it occupies during draught.

*Breast harness* is sometimes used as a substitute for a collar and in some countries it is employed to the exclusion of collars. A horse is more liable to gall with breast harness than a collar, yet it is frequently a useful method to apply, especially when the collar has galled the shoulders.

It should never be used without a swingle-tree, so as to reduce as much as possible the sawing motion which breast harness produces.

Injuries from this form of harness are very common, and the pad requires to be carefully fitted and frequently inspected; there must be no stitching showing on the surface next the skin, or galling will certainly occur. The neck-supporting strap of breast harness should be quite slack, otherwise when in draught the weight is brought on to the neck, and galling results.

*The Fitting of Bits* is extremely important, especially with young animals, the mouths of which are naturally very tender. A horse with a good mouth and manners requires nothing but a snaffle, and this may be plain, hinged, twisted, single ring, or double ring, depending upon the horse and whether for saddle or draught.

With most saddle horses a double bridle is used, viz., a snaffle and bit, and the best combination of these is seen in a Pelham.

Whatever is placed in the horse's mouth should not be fitted too high nor too low, but a position between the corner incisor and first molar selected, and this position is the one which does not wrinkle the skin at the angle of the mouth. The curb should lie in the groove under the chin, a loose curb may be of no use and unable to act, a tight one may cause an accident, and under any circumstances is unnecessary. The curb should be capable of exercising pressure without a strain on the head stall; nothing more than this is required with the majority of horses.

The injuries inflicted by bits occur at the angles of the mouth, on the rami of the lower jaw in front of the first

molar tooth, and to a less extent under the chin owing to the curb chain.

The injury at the angle of the mouth is caused by the snaffle being fitted too high, or to it being drawn across the mouth. Some horses have very sensitive corners to the mouth, and rubber placed on the mouthpiece, or a non-jointed mouthpiece, may be tried for these; but the principle is to lower the snaffle in the mouth, teach the rider not to pull his horse about and to keep his hands low.

Bit injuries are generally most severe, the action of a bit being to compress the rami. Partial fracture of the ramus is not uncommon; or as the result of pressure there may be necrosis of a portion of the jaw, the dead piece of bone varying in size from the thickness of a match to the size of a thumb, which after a long and tedious illness comes away or is removed surgically.

Such a mouth is for ever destroyed as a 'good mouth,' and very liable to be re-injured. If the horse is hard in the mouth, or a 'bolter,' a tight noseband may be used, or a nose-net, or a gag-snaffle, but a tight curb can only result in further damage. As a rule these injuries do not occur in the first instance as the result of the horse's fault, but from bad horsemanship.

#### DRAUGHT.

This is an extremely complex subject which lies mainly in the realm of the mathematician. The only aspect of the question of draught which will be dealt with here, is in connection with the simple practical points of the best means of utilizing animal labour.

We have previously noted that the horse from his construction is essentially devised for hauling a weight and not for carrying one. He utilizes his weight in draught by throwing his body in front of his feet which form the fulcrum, and the tendency of the body to descend is the means by which it acts against the obstruction. Traction is mainly a question of body-weight, and at p. 774

this aspect of the subject has been alluded to in speaking of the greatest muscular effort horses can exert.

The angle of traction is the angle of inclination of the traces, and much has been written on the most suitable angle for different kinds of work. It would appear that theoretically the angle is constantly altering depending on the inclination of the road and its character, and mechanisms have been introduced which are capable of automatically altering the angle to suit various conditions. In practice it is found that the traces should have a slight inclination downwards, viz., from the horse to the carriage, and this is true whether there be one or more horses employed. If this is not effected the leader's efforts are mainly expended in putting weight upon the back of the wheelers instead of exerting it on the carriage. Whether this is caused or not depends upon the type of harness employed; take for instance a tip-cart with a small horse as leader, the traces of which are attached to the point of the shafts; in such a case the effort of the leader is mainly expended in throwing weight on the back of the shaft horse. This may be an advantage in going uphill, as it artificially increases the body-weight of the shaft horse, but is a great disadvantage on the level. It is considered in a two-wheel cart, that the power of the horse is most effective when not more than  $\frac{1}{2}$  of the load rests on his back.

If roads were a dead level and frictionless (which is impossible), a horizontal trace would effect its purpose, but as in draught the weight has not only to be hauled but also lifted over every obstruction, a trace at an angle is obviously the correct mechanical system to adopt.

There is a great loss of power caused by working horses in pairs placed in front of each other; the effective power is not increased in the same ratio as the number of horses. They are worked in this way mainly as the result of convenience, as there must be some limit to the width of a road.

In agricultural operations advantage is taken of having

plenty of room, and three horses may be worked abreast by means of a mechanical contrivance known as equalizing whippletrees (Fig. 205). The mechanism is adjustable, so that the horses may be placed closer together or wider apart; and it may also be arranged so as to save a weak or young horse.

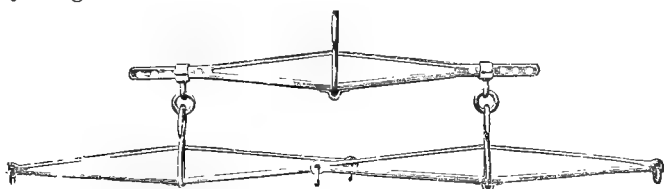

Fig. 205.—Adjustable Whippletrees to enable three horses to work abreast (Ransomes, Sims and Jefferies).

An equalizing chain and pulley for a plough attachment is shown at Fig. 206. The chain passes around a pulley so that the animals pull against each other, and none can escape their share of the work.

Experiment shows that, generally speaking, a wide tyre to a wheel renders traction lighter than a narrow tyre; the only advantage of a narrow over a broad tyre is on a very dusty road.

The height of a wheel has also an influence in traction; high wheels diminish draught, while a small wheel not only

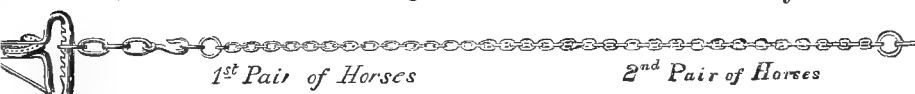

Fig. 206.—Equalizing Chain and Pulley for four horses to insure each animal takes its share of the work (Ransomes, Sims and Jefferies).

increases it, but is more destructive to roads. It is an advantage to have wheels which 'track,' viz., the fore wheels the same distance apart as the hind, as the fore wheels in heavy ground prepare the road for the hind, and so reduce the force of traction.

The weight in a four-wheeled waggon should be equally distributed over the four wheels provided they are of the same size, but if the front wheels be smaller than the hind, then less weight should be placed upon them.

*Roads.*—The condition of roads has its hygienic aspect ; a good road reduces traction, and good roads, whether in town or country, are expensive to make, and need frequent repair. No good road can exist unless the part be properly drained, but for this purpose undue curvature should be avoided, as affording no level surface to work on.

On reference to the table (p. 775) the force of traction employed on different kinds of road may be seen.

The least destructive roads for horses are those where a gradual rise and fall occurs ; roads on a dead level have always been observed to wear out horses quicker than those which are gently undulating, and the explanation is that on the dead level there is a uniform and constant strain which is relieved on the undulating road.

Experiments have been made to determine the comparative safety of certain pavements used in cities, and the following results were obtained in London :

A horse will travel 132 miles on granite pavement without falling.
"    "    191    "    asphalt    "    "
"    "    446    "    improved wood pavement without falling.

A dry granite pavement is very slippery ; a horse will only travel 78 miles on dry granite without falling as against 537 miles on wet.

On the other hand, both wood and asphalt are safer in the dry condition :

On dry wood a horse will travel 646 miles without falling.
"    damp    "    "    193    "    "
On dry asphalt a horse will travel 223 miles without falling.
"    damp    "    "    125    "    "

Both wet wood and asphalt are safer than 'damp,' doubtless for the reason that the greasy coating gets washed off.

Wooden pavement is less slippery than either asphalt or granite.

*Springs.*—Every effort should be made to reduce as far as possible the force of traction, and some of the methods

of accomplishing this we have mentioned above. It is obvious that the friction between the wheel and an ungreased axle is a most serious source of loss of power, and moreover an act of cruelty. The introduction of springs into waggons is another method of saving the strength of animals, for springs reduce the force of traction by about one-fourth to one-sixth. Springs in the traces are sometimes used, but these are only for the purpose of saving the shoulders.

## SECTION II.—CATTLE, SHEEP, PIGS AND DOGS.

### CATTLE.

Cattle are kept for two specific purposes, viz., either the production of flesh or of milk. Both of these are so intimately mixed up with the question of feeding, that some repetition of this subject is unavoidable. As the successful management of cattle depends upon a good system being adopted and strictly followed, it will facilitate our study of this question by considering—(1) the management of the calf, (2) the management of the cow, (3) feeding and management of cattle kept for feeding and breeding.\*

#### *Management of Calves.*

Whether the calf-rearing industry should exist on a larger scale than it does at present, is an agricultural

\* In the preparation of this section we have drawn our information from the most reliable sources: 'The Complete Grazier,' by Dr. Fream; 'Stephens' Book of the Farm,' Mr. J. Macdonald; 'Cattle, Breeds and Management,' Live-Stock Handbook, Mr. W. Housman. Many papers in the *Journal of the Royal Agricultural Society of England*, especially that in vol. v., 3rd Series, on the 'Management of Aberdeen Angus Cattle,' by Mr. C. Stephenson, F.R.C.V.S., and others previously quoted in these pages. In connection with this Section the remarks on the Production of Fat, p. 121; Feeding of Cattle, p. 123; Feeding of Sheep, p. 131; Feeding of Milch Cows, p. 133; Feeding of Calves, p. 137; and Feeding of Pigs, p. 132, should also be consulted.

question which is outside our province. The trouble and care required by calves certainly cause many farmers to neglect this side of their industry, and further in dairy farming the calf is regarded as a necessary evil to be got rid of as early as possible. Yet it is obvious the greater the home production of cattle, the less demand there will be for foreign importations.

Earlier in these pages farmers were urged to breed their own stock. This is the advice given by the highest agricultural authorities, and is moreover sound common-sense. An intelligent farmer by rearing his own stock could in course of time not only get rid of tuberculosis, but remain permanently free.

Home reared stock should be kept quite apart from the cows which farmers have to purchase as occasion arises, in order to make up their milk contracts.

The housing of calves has been dealt with (see p. 334), and the importance of an impervious dry floor, fresh air, daylight and cleanliness, has been insisted upon. It is considered by many that where calves are brought up by hand they are best kept in separate cribs to prevent them sucking one another, if herded together it may be found necessary to muzzle them to check this practice.

Though calves are generally hand-reared, the natural method is to suckle the mother. Economic considerations necessitate artificial rearing, which can be quite safely and successfully employed, provided definite conditions are followed. Natural feeding is always adopted among pedigree stock, and by others where the milk is not of primary consideration.

Calves to be hand-reared should be separated practically immediately after birth, that is as soon as they have been licked by the dam, and are able to get on to their legs. At this time the udder contents are generally available for them, though some farmers use the colostrum for the purpose of making custards. In such cases treacle is given to the calf with the first milk, in order to act as a purgative. Early separation may prevent difficulty later on, otherwise for



the first few days the calf might remain with its mother. On the separation taking place the first thing is to teach the calf to drink, and this by the exercise of a little patience is soon acquired. One or two fingers placed in the mouth at once induce sucking, and the pail containing the colostrum or milk is held under the mouth, which is slowly lowered towards the fluid until it touches it. The fingers may now be withdrawn gradually, the calf in the act of sucking being able to draw up a little milk, while the head is gently held so that the lips are kept under the level of the fluid. It may be necessary to introduce the fingers again with the head in this position, but very shortly the lesson is learned, and in a day or two the calf will drink voluntarily on the pail being presented.

The fingers of the nurse should be clean, and the vessel holding the milk must be above reproach. We have seen (p. 595) that 'white scour,' the bane of calthood, is produced by a filth organism that probably enters by the digestive canal, and which cleanliness can control.

But apart from this there is another form of gastrointestinal disturbance due to dirty pails, sour milk, etc., which is also obviously under control.

The question of the frequency of feeding calves has been dealt with on p. 137. Four times a day at least is required, not twice a day as is commonly the case, which frequently leads to the young animal overloading its stomach with milk, and producing stomach and intestinal disorders.

Whole milk for calf-rearing is not required provided an efficient substitute is used, full details of which will be given presently; but if possible it is best to give whole milk for the first week or two, and gradually substitute skim milk. The change on no account should be sudden. As we have seen, skim milk by itself is a starvation diet, with it must be added the milk substitutes. Even then the quantity given daily must be carefully regulated to avoid stomach and bowel irritation.

The amount of milk allowed daily for the first few weeks of existence varies from four quarts during the first two

weeks to six quarts daily during the sixth week of life. These are the minimum amounts which should be given daily, whether pure milk or skim milk with substitutes be used.

But it is most essential to watch the animals and be certain that they are not overdone; an error on the other side is preferable. They should neither suck nor drink to repletion; at the same time there must be no loss of condition. When the milk substitutes are employed they should be slowly and carefully introduced, gradually dropping the whole milk until skim milk and substitutes are tolerated by the stomach.

The following milk substitutes are taken from Fream.\*

For the first four weeks a mixture of new and skim milk; after this strong water-gruel, consisting of equal parts of bean or oat-meal, mixed with one-half of butter milk, carefully stirred with the gruel after the latter is cooked.

Three parts of milk and one of hay tea, gradually increasing the proportion of hay tea.

Hay tea with finely powdered linseed cake, the latter being boiled in the hay tea to the consistence of a jelly; no milk given.

A porridge made of wheat-flour, boiling water, and skim milk.

Three quarts of linseed meal, four quarts of bean meal, thirty quarts of boiling water, cover up for 24 hours; then add thirty-one quarts of boiling water, which is poured in slowly, stir well and boil for half an hour. This is given blood warm with an equal proportion of new milk, increasing the substitute to two-thirds as the calf gets older; after a month skim milk takes the place of new, and after six weeks the mucilage is given alone.

Two-thirds oatmeal, one-third crushed linseed made into a porridge, and mixed hot with skim milk.

Half a pint of linseed meal scalded and added to one quart of skim milk.

Linseed cake finely ground seven pounds, mixed meal (equal parts of wheat, barley, oat, and bean meal) seven pounds, hay tea two gallons, hot water four gallons.

Probably the best artificial milk for calves consists of separated milk

---

\* *Op. cit.*

to which linseed meal or oatmeal is added to take the place of the cream. The milk is separated at once, and in consequence of this its temperature falls, which must be raised before administration.

All pails and vessels used in the process of preparing milk substitutes, must be kept scrupulously clean or trouble will follow. In the above milk substitutes it must be understood that all of them are raised to blood-heat before being given.

We have previously referred (p. 334) to the admirable article on the rearing of calves by Rev. John Gillespie, in which he gives to farmers the most excellent advice in connection with artificial feeding :

‘Where pail feeding is followed, the person in charge must be thoroughly reliable and very painstaking. The food must be given with very scrupulous care and regularity ; this is important when nothing but the natural food of new milk is being given, but where the milk is supplemented by other articles, and a mixed diet given, care and attention at every stage are of exceptional moment. If the ingredients are not used in the proper proportions, or the constituents are not evenly mixed ; if the right quantity is not given to each calf, or at the proper temperature—when some or all these important conditions are not complied with, and especially when all of them are neglected, the result cannot but be unsatisfactory.’

At a month old the calf may receive a little hay, finely shred roots, and cake in powder, given in two meals a day, still continuing with the milk, or its equivalent, until the amount of fluid consumed at two months old amounts to two gallons daily.

It is during the first three weeks of life that especial care must be exercised in the feeding of calves ; irregular feeding, long fasts, or an excessive allowance are the points to guard against, while cleanliness in the matter of food and surroundings is imperative.

When the matter of taking a little solid food is firmly established, the amount of milk or substitute may be gradually reduced, say from two months onwards, so that by the third month the process of ‘weaning’ may be begun.

The natural method of suckling is adopted in all pure

bred stock, and by some other breeders; the calf being allowed with the dam either to suck at pleasure where the milk is no consideration, or to have access at regular intervals.

A cow can sometimes suckle two calves, especially if a deep milker, and in this way the milk of another is available. It is, however, generally considered best to combine milking with suckling, as otherwise the cows may later on be difficult to milk with the hand.

In the case of heifers with a calf at foot, and not intended to be added to the stock, the suckling process alone may be followed, as milking by developing the udder would spoil her sale in the fat stock market.

The pure bred calf practically gets all the milk it needs, though in some pedigree herds hand feeding is practised. The calf remains with its dam for six or seven months before weaning is adopted, and during that time it may occupy a compartment in the same box, or be brought regularly to the dam, or live with her constantly either in the box or at grass, different systems being followed in various herds.

Weaning is no trouble when hand feeding is practised, but in pure bred herds it must be prepared for between the sixth and eighth month by feeding on artificial food, so as not to have an abrupt transition. Gradually the amount of milk must be reduced until the calf has access but once a day, and then only after the udder has had some of its milk removed.

Linseed cake, hay and pulped mangels form an excellent diet for a calf, and when properly established the weaning process may be made complete.

In the early management of calves, Stephenson\* lays great stress upon their breaking, which must be carried out by a combination of care and firmness. The young animals must be haltered, and tied up in such a way as not to hurt themselves, for struggling is to be expected, and injury prevented by a little forethought; temper may be shown by

\* *Op. cit.*

some, but on no account should this be met by anything but firmness. In the course of a few days they surrender their freedom and learn to stand quietly.

In modern fittings the head stall is attached to a swivelled chain which slides up and down on a vertical bar. In Scotland a 'seal' is used, consisting of a chain which passes around the animal's neck, and connected with another chain, at the end of which is a ring which slides up and down a stake placed at an angle. This method leaves the animal perfectly free to lick itself, and is very secure.

The next lesson imparted in the case of bull calves intended for exhibition is to teach them to lead and turn to either hand; this is also quickly learned and never forgotten.

At the same time the young animal should be taught to have its feet lifted and held up, so that later on no trouble is experienced when these have to be examined for disease or injury, or require reducing for overgrowth. This education is of the greatest importance in after life.

The castration of calves not intended to be kept is best carried out when a few weeks old.

Those to be reared as bulls are brought up on a more liberal diet; they are not removed from their dams for six or eight months, their subsequent diet is richer and more forcing, and with it they should have exercise and fresh air. They should be handled, groomed, and whatever building they are in should be freely ventilated. These bulls must be taught to walk, which is one of the essentials of success in the show ring.

As a preventive of quarter-evil most calves are setoned in the dewlap in the spring or autumn. Nothing is known of how this acts, but the idea is deeply rooted, and the operation may be beneficial; see also p. 591.

Before the bulls are a year old the usual ring should be inserted in the nose, but must not be used until the wound has perfectly healed. If previously handled the leading is only a matter of routine. Nothing should be done to upset the animal in the leading lesson; he should be soothed and

encouraged, and very soon learns what is required from him.

The little we have to say about bulls may conveniently be considered here. The adult requires exercise daily, the diet excepting during the season of service should be light, grass when available, hay, sliced roots, and if necessary a little cake and meal. Water should be at hand, and grooming should not be forgotten. During the summer he should be in a well fenced or walled paddock, with a shed for protection.

'Bulls are great thinkers and have wonderfully retentive memories; they must not be played with, teased, or ill used, the temper of many a bull has been ruined by such treatment. Do not make an unnecessary fuss about the bull. Be gentle, yet firm without harshness, and he behaves like a gentleman; use him roughly or strike him wantonly and he will certainly never forget it, but will wait his time and pay it back with compound interest' (STEPHENSON).

#### *Feeding of Cows.\**

It was first proposed by Lawes that dairy stock should be fed according to their yield of milk. It was calculated that it required 4 lbs. cake and 4 lbs. bran to contain the ingredients in 3 gallons of milk, and this was fixed as the food basis for a three gallon production. For each rise or fall of 2 lbs. of milk one-quarter of a pound of each is added or taken off; so that a cow yielding only 2 gallons instead of 3 would have  $1\frac{1}{4}$  lbs. less of each food, viz.,  $2\frac{3}{4}$  lbs. each of cake and bran, while a cow yielding 4 gallons of milk would receive  $5\frac{1}{4}$  lbs. of each food.

To carry out this scheme a milk register has to be kept, a system which exists in all well-conducted dairies, and it has been shown that considerable saving in food may under this scheme be effected. Lawes first pointed out that the fluctuating yield of milk of each cow, from the time of calving to that of dryness, gives more scope for economy in the feeding of milking cows than in the fattening of oxen.

The following method or system of feeding cows in milk,

\* See also p. 133.

in addition to those mentioned on p. 133, are useful as showing the diversity of details in different parts of the country.\*

A well-known feeder in Derby considers 28 lbs. roots the limit for a cow in full milk, to which he adds the following liberal daily ration :

Cut hay and straw...	...	...	...	Lbs.	20
Bean meal	...	...	...	...	2
Ground oats	...	...	...	...	2
Mixture of wheat and barley meal	...	...	...	...	2
Linseed	...	...	...	...	2
Bran	...	...	...	...	2
Roots	..	...	...	...	25
Long hay in two feeds	...	...	...	...	5
					60

All but the hay is cooked or steamed, and the food given at a temperature of 55° to 60° Fahr.

In Staffordshire an experienced feeder chaffs all his straw, pulps his roots, partly chaffs his hay, and mixes them together. He makes no attempt to weigh the quantities given. Four lbs. of linseed or cotton cake, and 2 lbs. of meal are added to the daily diet, with one foddering with long hay at night. The hours of feeding are 6 a.m., 7.30 a.m., 3 p.m., 4.30 p.m., 5.30 p.m.

A well-known Irish breeder of dairy stock gives daily :

Roots	...	...	...	...	Lbs.	50
Hay	..	...	...	...	...	10
Barley meal and crushed oats	...	...	...	...	...	4

Feeding in Ayrshire :

Hay	...	...	...	Lbs.	4½ at 5	a.m.
Boiled roots with chaff or cut hay, mixed with bean meal	...	...	...	2½	at 7	,,
Hay	...	...	...	4½	at 7.30	,,
Hay	...	...	...	4½	at 10	,,
Turned out to water and air	...	...	...		at 11	,,
Boiled roots, chaff, and 2½ lbs. of meal (as at 7 a.m.)	...	...	...		at 4.30	p.m.
Hay	...	...	...	4½	at 5	,,
Hay	...	...	...	4½	at 8	,,

\* These diets are taken from Stephens, *op. cit.*

In this dietary the hay is in large amounts ; the dry cows get nothing but oat straw and turnips, as follows :

				Lbs.		
Oat straw	...	...	...	5	at 5	a.m.
Soft turnips	...	...	...	20	at 7	,,
Oat straw	...	...	...	5	at 7.30	,,
Oat straw	...	...	...	5	at 10	,,
Exercise and water	...	...	...		at 11	,,
Oat straw	...	...	...	5	at 2	p.m.
Soft turnips	...	...	...	20	at 4.30	,,
Oat straw	...	...	...	20	at 5	,,
Oat straw	...	...	...	20	at 8	,,

In a Northumberland dairy the following forms the daily ration :

Barley and maize meal	...	...	...	6 or 7 lbs.
Hay	...	...	...	21 lbs.
Turnips	...	...	...	42 ,,

In pure bred herds there is great variation in the method of feeding, some doing the cows most liberally, others sparingly. The overfeeding of breeding stock is a thing to be avoided, as it interferes with conception.

As a preventive against parturient apoplexy dairy stock should be kept somewhat low a month before calving, and a purgative administered. This should be particularly observed in the case of the third calf, which experience shows to be the most fatal. Thornton tells us in Jersey exercise before and after calving is regarded as an important preventive. Old village people unable to work earn a few shillings weekly by leading out cows to walk. Jersey cattle, he says, were immune to Milk Fever until a more forcing system of feeding was adopted. Roots are seldom given to the cows before calving, the animals are kept on dry food with a weekly dose of salts and sulphur.\*

We are informed that many Jersey cattle which are not overfed, suffer from parturient apoplexy.

#### *Feeding for the Butcher.†*

When cattle are fed in yards or courts, care should be taken not to overcrowd, for apart from the hygienic disad-

\* 'Jersey Cattle and their Management': Mr. Thornton, *Journal of the Royal Agricultural Society*, vol. xvii., 1881.

† See also pp. 121, 123.



vantages there is also the risk of loss by injury, and the damage done to timid animals by an aggressive neighbour. Cattle of the same age and size should as far as possible be placed together.

In the feeding of store cattle, and the same applies to cattle fed for shows, each animal must be fed according to its appetite, so that an experienced and intelligent cattle-man is required. Overgorging must be avoided; no matter what the food is, only the amount which each animal can consume should be given, food lying in the trough and rejected through repletion is a wasteful practice.

All feeders of repute acknowledge the above, with regularity in feeding, to be the secret of fattening animals, and that the man who is unable to accurately gauge each animal's appetite to a nicety, is unfit for the duty of cattle-man.

Home bred cattle fed for beef will be from six to nine months of age at the beginning of winter, and in days gone by the idea of regarding these in the light of store cattle would be ridiculed; but the early maturity movement has insisted on this, and mere calves before completing their first year are regarded in this light, while at eighteen or twenty months old they are fat cattle.

Early maturity is insisted upon both on economical grounds, and also because young animals put on more flesh per pound of food than older animals do.

The calves remain at grass as long as it lasts, receiving in addition manger feeding in the form of a few pulped or sliced roots, straw, and a pound or two of cake; they remain out all day, coming in earlier in the evening as the nights get colder. They are comfortably housed or placed in a well-sheltered yard. Finally, as the weather increases in severity they are completely housed, though this system depends upon the part of the country and the severity of the winter. Shelter during the winter is most important if economical feeding is to be practised, but this shelter does not mean an absence of fresh air. During the whole winter, roots, cake, and straw form the entire winter diet, until the grass comes in the spring.

In Scotland nothing but turnips and oat straw are given through the winter (see p. 262). The roots are given in the morning between 8 and 10 o'clock, and again in the afternoon between 2 and 3 o'clock; but it is better to feed with roots three times a day, viz., 6 a.m., 10 a.m., and 3 p.m., as the cattle are more contented. The straw is given between 5 and 6 a.m., 11 and 12 noon, and between 3 and 4 p.m., with sometimes a fourth feed of straw between 6 and 8 p.m.

When the spring arrives the young animals are turned out on the pastures, but frequent shiftings are necessary. Shelter sheds from sun, rain, or flies throughout the summer are very desirable. The most difficult time for the grazier is the autumn when the grass is short and the pastures dried up. It is essential in order to avoid loss of condition that hand feeding should at this time be practised, unless the farmer has some reserve crop to fall back on. The finishing off of the animals for the market may now be made by means of meal, cake, roots, hay or straw.

Purchased store cattle can be kept in good thriving condition during the winter on 3 lbs. cake, half being given at 6 a.m. and half at 1 p.m., with 50 lbs. roots, divided into two rations, about 9 a.m. and 3 p.m., and plenty of cut straw or hay three to four times a day. Later on, as the period for slaughter approaches, cake and grain are given, either singly, or mixed, from 4 lbs. to 6 lbs. daily, in two equal feeds in the early morning and afternoon.

A well-known Scotch breeder employs all his roots in a pulped condition for fattening cattle, and mixes them with the other food; the animals in the first instance are sparingly fed with this pulped mixture, as they are liable to overdo themselves.

The pulped mixture consists of :

Oat straw or chaff... ..	...	...	14	} Well mixed together, turned over two or three times, and allowed to fer- ment for 24 hours before use.
Pulped roots ... ..	...	...	56	
Cotton cake, decorticated	...	...	4	
Molasses or locust bean meal	...	...	1½	
			<hr/> 75½	

The above is a full day's ration, but when animals are first brought on to this diet, say in December, they do not receive more than 30 lbs. daily of the mixture, a month later 45 lbs., and on the first day of every month thereafter 15 lbs. more, until the daily amount consumed is as above.

As the fattening process under the mixture goes on, one or two pounds of linseed cake are given to all animals about April 1, while to those showing a decided inclination to early fattening, two to four pounds of cake are given, so that by June they are in prime condition for the fat market.

The months given above are those mentioned by the feeder, but it is obvious such a system is capable of application at any time where local conditions are favourable.

One of the greatest beef feeders in Aberdeenshire always ties up his cattle intended for the Christmas market early in the autumn; he considers that the stall method is preferable to the yard, as it is easier to increase or decrease the amount of food. The first diet given is a mixture of tares, white peas, and oats, which are sown in equal proportions, and cut when the tares are three parts ripe. The tares with fresh clover form an excellent feeding mixture. With this is given two to four pounds of cake a day; later the tares are replaced by turnips and then by swedes. By the middle of November the amount of cake should be 4 lbs. a day, while a feed of bruised oats and barley is also given; by December 14 the animals are fit for market. Six weeks is considered by this feeder to be the limit during which he can economically feed on cake and corn.

The following system of feeding and byre routine is followed by another celebrated Scotch feeder: At the end of the grazing season when the cattle are housed, they are placed on 2 lbs. decorticated cotton cake, and 2 lbs. linseed cake. This is gradually increased to 3 lbs. each; by degrees cotton cake is withdrawn, and the same amount of linseed substituted. Early in November the cattle receive

in addition bruised oats, 2 lbs., pea or bean meal, 2 lbs., slightly moistened with water. Half the daily allowance of cake is given at 6 a.m., and a feed of cut turnips at 9 a.m.

During the above hours the byres are cleaned out, and the animals groomed ; when the turnips are finished a small amount of oat-straw, or hay is allowed.

Perfect rest is given until 1 p.m., when they receive cake, roots, and straw or hay, as in the morning, with hay or oat straw again at 8 p.m. The feeding, grooming, and cleaning are done with clockwork regularity, and the feeder above mentioned considers that no cattle man can successfully feed, until he knows exactly how much his animals can eat without leaving a morsel.

The methods of fattening adopted in England are by no means identical with those in Scotland ; the difference in the climate, and the longer time available for agriculture are factors which affect this ; the food supply is also not identical. Turnips and oat straw to the Scotch feeder are what the swede, mangel, and hay are to the farmer of the south. More green stuff is also grown in the south as compared with the north, while in the finishing off of cattle a more liberal use of cake is made in England as compared with Scotland.

A Bedford feeder, for example, houses his fattening animals when the grass ends, and finishes them off on hay, hay chaff, a few roots, seven or eight pounds of cake, and one peck of a mixture of barley and bean meal daily.

In Hereford the young cattle in their second year, while still on grass, get four pounds daily of cotton cake and ground corn (wheat, barley, or oats). The animals are housed in September, and receive as much linseed and cotton cakes, with bruised corn, as they can eat.

In Norfolk, owing to the system of agriculture, there is very little opportunity for grazing, but an abundant supply of roots is available, and these are largely used in the feeding of fattening stock, together with cake, hay, grain, and straw.

The following rations are selected from different parts of England :\*

I.

Cake	...	...	6 lbs. daily.	Half morning and night.
Mixed meals	...	...	2 galls.	Half morning and night.
Roots	...	...	$\frac{1}{2}$ to 1 bushel.	After breakfast.
Long hay and hay chaff mixed with roots at 8 p.m.				

II.

Cake	...	...	...	Lbs.
Corn	...	...	...	4
Hay	...	...	...	4
Roots	...	...	...	7
Oat straw	<i>ad lib.</i>			60

III.

Swedes	..	...	...	Lbs.
Meal	...	...	...	100
Cake	...	...	...	4
Chaff scalded with linseed tea				
<i>ad lib.</i>				

IV.

Linseed cake	...	6 lbs. to 8 lbs.
Crushed beans or		
peas	...	1 gall.
Hay and cabbage.		

V.

Mixed meals	...	...	4 lbs
Linseed cake	...	...	4 "
Pulped roots	...	...	28 "
Chopped hay and straw.			

The mixed meals consist of equal parts of oats, wheat, white peas, and linseed, ground and mixed.

A well-known breeder in Monmouth fattens his cattle in the open during the winter, in a sheltered and warm part of the farm. The animals get what grass is available, and a great deal of cake and meal; six pounds of a mixture of these are given to begin with, and during the final fattening months from twelve to fourteen pounds daily divided into two feeds at 7 a.m. and 5 p.m.† In addition they receive straw, hay, and roots, according to their market value.

*Feeding for Exhibition Shows.‡*

In the fattening of animals for shows a much slower system is pursued, and the calf is frequently left with the dam for some months. After removal he is measured at

\* Taken from 'Stephens' Book of the Farm.'

† It is very doubtful whether more than seven pounds of cake per diem can be digested.

‡ See also p. 129.

the girth, as girth measurements are an unfailing indication of development, and this is repeated monthly.

The following is a system for feeding stock for exhibition, beginning with an animal 10 months old :—

2 lbs. linseed cake with some hay	...	...	6 a.m.
Exercise	...	...	7 to 8 a.m.
15 lbs. to 20 lbs. turnips, with a little oat straw			
or hay	...	...	8 a.m.
Grooming from	...	...	8 to 9 a.m.
Rest from	...	...	8.30 to 12 noon.
3 lbs. linseed cake with a little hay, followed			
by 15 or 20 lbs. roots	...	...	12 to 1 p.m.
Rest	...	...	1 to 5 p.m.
20 lbs. roots, with little hay or oat straw	...	5 p.m.	
2 to 3 lbs. bran, 4 lbs. barley and bean meal	...	8	,,

The secret of successful feeding we have before mentioned, but it cannot be too often repeated. Never give animals a chance of leaving food, their appetite must be gauged with exactitude.

In the summer feeding of show stock, grass takes the place of roots, while the food substances are increased as the animal gets older, so that at 2½ years they may be receiving—

7 lbs. linseed cake.		6 lbs. or 7 lbs. meal.
4 lbs. bran.		And a few turnips.

Regarding the criterion of girth measurement for fattening animals—

At	9 to 10 months	the girth should be	5 feet.
At 1 year and 10	„	„	7 „ 3 inches.
At 2	„ 10	„	8 „ 6 „

But nothing can take the place of the test by weight.

#### *Cattle prepared for Breeding Shows.*

In this case the young animal remains with its dam for eight or nine months, and at leaving receives :—

2 lbs. to 3 lbs. linseed cake.		3 lbs. bran.
1 lb. cotton cake.		2 lbs. barley and bean meal.

Straw as much as it can eat with a few roots.

The diet is increased with age, but the golden rule in cattle feeding is never forgotten.

In the winter the animals must be housed and made comfortable, but not too hot.

In the summer they are turned on to the pastures, but if the weather is hot it is preferable to turn them on only at night.

Show or other animals fed on milk, sugar, and condiments, are unsatisfactory. Milk develops a soft fat instead of a hard firm feel; sugar for breeding animals is said to affect their procreating functions, while there is abundant evidence that condiments are perfectly useless for the purpose for which they are given.

*Cattle House Routine.*—The routine of the farm may here be considered. The first duty in the early morning is the removal of the dung from the stalls of the cow byre, in order that milking may be carried out. The fattening stock are then attended to, every trough being cleared out of any refuse food it contains, and a fresh supply of roots given. This work must be done systematically, and always in the same definite order, by which means the cattle are not disturbed or disappointed by being kept waiting; they soon learn the system employed, and provided punctuality is observed they are patient.

From the fattening stock the bulls and extra cattle in courts or hammels may be attended to, the same routine of clearing out the troughs and supplying with roots being observed.

The heifers in calf and cows are frequently not given roots the first thing in the morning, but only straw or hay, and during the time this is being eaten the stalls are thoroughly cleaned out, the gutters swept clean, and the material removed from the building. Straw or hay is believed to be the best foundation for roots which now follow, each cow being fed in a definite order which is always maintained. If some straw can be spared for litter it is put down in the stalls, but frequently this cannot be afforded, though other

litter substitutes like peat may be employed. The cows are now left quietly by themselves, and the fattening animals in stalls and hammels are given fodder, that which was in the racks being spread over the ground and used as litter.

When the weather admits, cows are always turned out for an hour or so about mid-day, during which time they are generally watered.

An afternoon and evening feed is given to all animals in the order previously mentioned.

The important point illustrated is method and system. The same thing must be done every day at the same time and in the same order; otherwise cattle become impatient and lose condition. Whatever system of feeding is found by experience to be the best, is the one to be followed; a scheme for the day's work becomes elaborated, and if the best results are to be obtained it is followed with precision and exactitude.

In well-regulated herds the grooming of cattle is not neglected. It is true that when the method of tying up admits of it, the bovine does a liberal amount of skin cleaning with the tongue; this is a healthful and essential exercise denied the animal when two are placed in one stall, or tied up so short by the head as to be unable to turn round.

Grooming is probably more generally practised for show cattle, but it should form part of the routine of all well-conducted dairies, not only for the health and appearance given the animal, but as a hygienic matter in connection with milk-supply. Grooming enables the thighs, quarters, belly, and udder to be kept clean.

In this operation curry-comb and brush are used, not during the time the animals are feeding, but in the interim. Besides the body brush, wisps may be employed, and if the cattle have been taught early to allow their feet to be handled, these may be kept clean by washing.

Among show cattle even periodical body washing with water is practised, in order to get the hair and skin in fine condition.



## SHEEP.\*

The management of sheep is largely centred in the lambing-pen, for it is here that the chief mortality occurs. There is no difficulty in fattening sheep, they give very little trouble under the watchful eye of a good shepherd when intelligently fed and looked after, but the lambing time is one of anxiety and mortality.

The diseases from which they suffer are mainly those which are preventable, and within the bounds of cleanliness to either control or completely eradicate; abortion, septic arthritis of lambs, septicæmia of ewes, contagious mammitis, and contagious aphtha of lambs, are doubtless all microbic. Turning to other diseases not connected with the parturient period, contagious and non-contagious foot-rot, may both be controlled by hygienic measures, and the several parasitic attacks of the skin due to flies and acari are entirely within the laws of prevention; while even the ravages caused by such internal parasites as fluke and bronchial filaria are capable of considerable control.

*Feeding of Sheep.*†—The management of sheep varies with the part of the country; Scotch and English methods are not identical, and even in the various parts of England they differ greatly. The system of management depends upon the nature of the farm, and whether the animals are to be brought up under natural conditions or forced.

The summer feeding of sheep which are living under natural conditions is very simple, and consists of grazing with or without trough food, depending on the nature of the pasture and the custom of the country, but as a rule some oats and cake are given in addition.

\* In the preparation of this subject the following works have been drawn on: 'Stephens' Book of the Farm,' by Mr. J. Macdonald; 'The Complete Grazier,' by Dr. Fream; 'The Lambing-Pen,' by Mr. Harold Leeney, M.R.C.V.S., *Journal of the Royal Agricultural Society*, vol. vii., part iv., 1896; 'Sheep, Breeds and Management,' Professor J. Wrightson, M.R.A.C., F.C.S., *Live-Stock Handbooks*, No. 1.

† See also p. 131.

The grazing may be open or the sheep folded, the system adopted depends on the character of the grazing and the available crops for summer feeding. Many good sheep breeders combine the systems, allowing freedom during part of the day, and close folding at the other. At present we are only referring to summer feeding; during the winter while the sheep are on roots close folding is the rule.

Close folding has the advantage of feeding down the pastures systematically, while the grasses suffer no destruction from being trampled. Another markedly economical advantage is that, as every flock consists of sheep in different states of development, those for sale as mutton get the first bite of the new fold, the less forward ones follow and take a good deal that the others leave, while the stock ewes come last and clear up. But this latter by no means indicates that ewes need little in the way of keep, and if the above system of employing them as scavengers is carried too far, the ewes get poor and low in condition, and unfit for the drain on their system which is to follow at lambing time.

When the ewes have lambs the system of close folding may be practised by the use of the lamb hurdle, which allows the young animals ample opportunity of moving about, while the openings in the hurdles admit of them at once returning to their dams if alarmed or hungry. In this way lambs get the liberty they require. Close folding where sheep are forced in their maturity, is of the greatest advantage in furnishing that variation of food which appears essential to forcing lambs. In this way sheep may have two or three changes of green stuff in the course of a day; for example, a fold of vetches, rape, clover, or sainfoin may be used alternately during the course of a few hours.

In forcing lambs especially, trifolium, vetches, rape, and later on cabbage, are the great fodder crops available for summer feeding, while the spring feeding is met by rye, winter barley, and winter oats. Experience shows these fodder crops are best fed mixed rather than singly.

Besides these, there are permanent and temporary pastures to which sheep may have access, while when liberal feeding is desirable, cake, corn, beans, or peas in suitable proportions may be trough fed.

It is no use putting more sheep on a farm than it can carry. Where fodder crops are specially grown for their consumption a larger number may be maintained, but when no special provision of this kind is made, and the sheep have to depend entirely upon ordinary grazing, the greatest care must be paid to avoid overstocking.

Sheep may exhaust a land under a bad system of management, by which they take everything from the soil and return but little. Under enlightened management they may be a means of improving the soil, which is easily accomplished by hand feeding, of which the best are probably cake and corn.

Cake and corn cost money, and it is only to a limited extent that they can be afforded to ordinary sheep. Linseed is preferred to cotton cake, though the latter may be given to adult animals without injury. Beans and peas are good sheep foods. Cake should be given in small quantities to begin with; fattening sheep may have from one-quarter to one pound a day. The breeding flock only receives cake and corn from the lambing to the weaning period, in order to insure a good supply of milk. The administration of these expensive foods depends entirely on the object in view; as we shall see presently where forcing is the system adopted, they are used liberally and work out economically. For the ordinary bringing up of sheep for the market, their use may be delayed until the final period for finishing off arrives, in the meantime depending solely on the pastures, seeds, and fodder crops, for the spring, summer, and autumn feeding.

The winter feeding of sheep in those cases where 'early maturity' is not practised is a more difficult matter. Under the early maturity movement, the lambs are converted into mutton before the winter arrives, but there are several breeds of sheep in which early maturity is not practised,

while later lambs of all breeds have necessarily to be fed through the winter.

The chief means of winter feeding lies in roots; of these turnips are the great standby. The change from open grazing to close folding on turnips must be made with the greatest care and judgment, or ill effects will occur. The sheep should only be close folded on turnips for a short time each day, and then returned to the stubble or such grass as is still available; or a few turnips, preferably white to begin with as they are softer, may be scattered over the pasture.

Sheep at this time should not be turned on to turnips in the early morning when they are hungry, but be kept until later in the day when they have hay, grass, or straw inside them. The tops of the turnips may be dangerous at any time, but particularly so when wet.

If no grazing is available some hay must be allowed, the feeding of a breeding flock on turnips alone is wrong, and though nothing approaching rich and high feeding is required for the ewes before the lambing period, yet they must be kept in good store condition, and this can only be effected by giving dry food with the turnips.

In Scotland oat straw and turnips are considered sufficient for the keep of sheep, but there are many flock masters who do not regard straw in this light, and the practice in England is to give an allowance of hay where necessary. Clover and sainfoin hay chaffed is excellent feeding for sheep, though ordinary hay is regarded by many as the best. With a sufficiency of hay and roots the winter may be faced with equanimity; the evils of overstocking are strongly brought home in the winter, when the land fails to help, and the hay crop is short. Without hay to mix with the roots the winter prospect is a poor one, further, it has to be remembered that hand feeding may have to be carried into May.

Swedes follow turnips, they require slicing owing to their hardness; mangels may be used after swedes, but their tendency to produce urinary trouble in male sheep (see p. 261) must not be forgotten.

Mangels and swedes given to lambs frequently produce a troublesome form of diarrhœa. These young animals should be brought on to roots with great caution, and only when an artificial food like cake is given, with hay and straw chaff added. There is a great prejudice against the use of turnips and roots generally for in-lamb ewes, it being stated they cause abortion. Under any circumstances it is wise to exercise the greatest caution in their use until after lambing.

Frozen roots are a well-recognised source of danger, and should never be used. Unripe turnips have been blamed for causing mortality among sheep; it is said that the irritating substance may be removed by 'pulling' the turnips, and leaving them three or four days before feeding. Sheep with defective teeth require their turnips to be cut, and there are many agriculturists who consider this method should always be adopted, in preference to the more wasteful one of feeding on the ground.

Where forethought is practised in breeding flocks, it is not unusual to reserve for the ewes some of the older grass for use in winter, so that care should be taken this is not eaten too bare.

Uncorticated cotton cake has been said to be a good substitute for hay and roots in wintering ewes, from half to one pound a head with oat straw and pea haulm being allowed.

*Production of Early Maturity.*—The forcing of sheep and production of early maturity is the outcome of recent experience. As previously mentioned, lambs are now sold as mutton eight months after birth, and weigh 10 stones; even 12 stones are possible. Practice shows that sheep lend themselves to early maturity more than cattle, and especially certain breeds of sheep such as the improved Hampshire Downs.

There is only one thing which is capable of producing this condition, and that is good feeding; it is true breed and soil influence the question, but the main factor is plenty of food, and frequent changes.

The dams of early maturity lambs must also be liberally fed after lambing, in order to get their milk in a good nourishing condition. Hay, turnips, swedes, and one pound of cake daily are necessary for this, and should be maintained for at least ten weeks. The lambs and ewes live in the open, but in well-sheltered, warm and dry pens.

The first indication of the lambs feeding of their own free will is looked for, and they at once come on to a little finely ground linseed cake, crushed oats, split peas, and malt, all gradually introduced, while the dam's milk is not neglected.

As soon as the first green food of the season is available, lamb hurdles are introduced, and the young ones brought on to rape. In March they get grass, and later on spring and summer fodder and crops, all of which have to be carefully arranged for during the previous autumn.

Close folding on these is the rule, though frequently the lambs are allowed a scamper. Change of food daily is essential in order to stimulate the jaded palate. By May they are weaned and the ewes go back on to ordinary keep, while the cake is expended on the lambs. The routine of their short life cannot be better described than by one of the authorities on sheep, especially of Hampshire Downs.\*

'The lambs awaken on a fold of vetches; the shepherd is up betimes and begins by giving them an allowance of cake, he next grinds up some mangel which they eat with relish. They are then admitted to a fresh fold of vetches, after which they are walked quietly away to a neighbouring piece of good rape or cabbage. After two hours or more and in the heat of the afternoon, they are allowed to spread themselves over some old sainfoin or aftermath clover. They will then return to the vetch fold, and after receiving another feed of corn they lie down to a well-earned repose, having increased their weight by 1 lb. each. Hay-chaff in troughs is also frequently supplied, even in summer, by way of keeping them firm in their bowels; thus a lamb may easily partake in one day of eight different kinds of food. Rape and cabbage or kale give way to turnips in late July or early August, and the allowance of 'corn' is kept up to from 1 lb. to 1½ lbs. per head.'

---

\* Professor Wrightson, *op. cit.*

The artificial product thus obtained goes to the butcher or is used for breeding purposes at eight months old !

*Weaning* generally takes place at about three or four months old, the dams may be entirely separated from the lambs, or a hurdle fold so arranged that they may see each other without being in contact. It is the duty of the shepherd to examine the udders of the ewes, to avoid the risk of milk collecting and producing mammitis.

In the ordinary fattening of sheep they should be kept in small lots of about forty, each day if possible they should be brought on to fresh ground, and the greatest regularity in feeding must be observed. Sudden changes in feeding must always be avoided no matter at what stage of fattening, but especially when the animals are being brought for the first time on to a fattening diet.

Rock salt should always be found in the feeding troughs ; its value in the prevention of fluke disease has previously been dealt with.

*Sheep Shelters.*—Very little attention has been paid to the question of shelters for sheep, and the matter has received some notice at p. 348. Here, however, we would remark on the advantage of obtaining on all farms where little natural shelter exists some artificial protection for sheep living in the open during wind and rain, and the best artificial protection of this kind is that known in Scotland as ‘Stells.’ Stells may be of various shapes, as in Figs. 207, 208, and 209, which show the plan of three well-known patterns ; and, according to their arrangement, stells may be either inside or outside. A stone wall six feet high is erected, with an opening leading to the interior, as in Fig. 207 ; or the protection is *outside*, as in Fig. 208, where the space within the wall consists of a plantation, while the recesses afford shelter no matter from which point the wind is blowing. The *inside* shelter provided in Fig. 208 is especially good, as these are not only the stone walls, but a plantation exists between them. Fig. 209 is the simplest form of outside stell, viz., four incurved walls.

At these places hay should be ricked so as to be con-

veniently handy for winter feeding. The necessity for protection of this kind on hill farms, especially during the winter, is very great, and in time would more than pay for its erection by the saving in food and in life.

Stall feeding of sheep has been tried in Scotland, but failed, though shed and yard feeding have given good results.

*Abortion in sheep* has been dealt with at p. 616, but it may here be remarked that there is a widespread feeling that

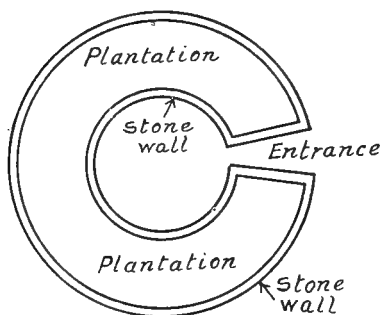

Fig. 207.—Inside 'Stell' for sheep protection (Stephens).

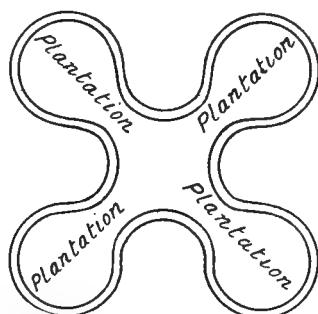

Fig. 208.—Outside 'Stell' with plantation (Stephens); the sheep are protected in the recesses.

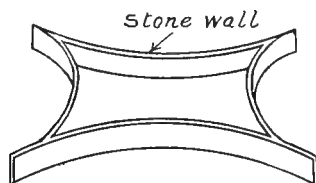

Fig. 209.—Outside 'Stell' without plantation (Stephens).

there are other causes in operation, quite apart from microbic infection. 'Roots' in various stages of immaturity, frostbitten, or in excess, have been blamed; cold winds, insufficient keep, wet and slippery ground, over-driving, and especially to being worried unnecessarily by the 'dog'; all these are put forward as causes in active operation.

Shelter, moving to higher and drier ground, with care and gentleness in dealing with them, are rational preventive



methods to adopt, in order to control abortion from the above causes.

Ewes, as we have previously mentioned, only require to be kept in good store condition until lambing occurs, but they must not be allowed to get too low, especially when the grass fails. Hay should then be given, and this will also prevent them from eating roots to excess, which is generally admitted to be dangerous with in-lamb ewes.

*Lambing Season.*—The lambing fold has already been described. There are several kinds, but the principle is much the same in all. The lambing season is one of mortality, from three to four per cent. of the ewes will die, either from difficulties in lambing or parturient after-effects. Nor is this to be wondered at, when it is borne in mind that shepherds, excellent as they undoubtedly are, indispensable though they be, are not learned in antiseptic midwifery, and despise the simple rules of cleanliness on which this is based. Cleanliness in the thoroughly surgical sense of the term, is only understood or appreciated by few outside the profession; so that soiled fingers, long and dirty fingernails, and rough instruments, take the place of skilled advice and antiseptics, with the result that the mortality is excessive.

But the whole of the mortality does not necessarily occur as the result of difficult presentations; parturient fever is common, highly infectious, and spreads by means of the shepherd, the soiled surroundings, and the after-births left in the pen. When this disease appears the lambing-pen must be at once broken up and destroyed; let it be set fire to, and the ground on which it stands thus disinfected. An opportunity should be taken of ploughing up the place and getting a crop off it. All membranes, fetuses, and dead ewes, must be buried deeply in lime in some place to which sheep have not access, and in this work on no account must the shepherd join. The sanitary measures for controlling this disease, will be dealt with presently in considering other infectious diseases of the lambing-pen.

One of the great difficulties in a lambing-pen is main-

taining a dry floor ; this can only be obtained by care in selecting the site, draining by means of surface channels any part that runs into it, so as to carry the water off, and raising the ground of the pens above the surrounding level with dry earth or burned clay, over which straw should be laid.

At times cow's milk has to be employed in the rearing of lambs and may produce diarrhœa, but besides this there is a very fatal form of diarrhœa among lambs two or three days after birth known as 'white skit,' due, it is supposed, to the disagreement of the ewe's milk. It is more than likely it is due to the same cause as white scour in calves, viz., an organism which enters the body by the mouth and perhaps navel. In combating this disease the ordinary method of moving the fold must be adopted, the destruction of the evacuations carried out, isolation of the sick practised, the greatest cleanliness insisted upon, and the group system adopted (see p. 495).

A green diarrhœa frequent at weaning time is considered by some to be more fatal than the white variety. Green diarrhœa is caused by sudden change of diet ; all changes in food should only be gradually brought about.

A very fatal form of aphtha occurs in lambs, probably the result of maternal infection. The teats of the ewe crack and ulcerate and so infect the lamb, which suffers in the mouth, nostrils, and lips. It is still a doubtful point, whether the dam infects the lamb, or the lamb infects the ewe. This is probably a purely infectious disease, and when many animals are affected it is a most difficult one to legislate for ; the ewes suffer from distended udders, the lambs from hunger owing to their inability to suck.

Small flocks can be dealt with, the ewes' udders being stripped, but where large numbers are affected it becomes impossible to deal with them. Isolation of the affected is of primary importance, grouping the cases into different degrees of severity, frequent changes of fold, insuring that hay racks and feeding troughs are put back in the pen they belong to, are elementary principles which suggest them-

selves. If it were possible to carry out, disinfection of the udder and mouth is of primary importance. Under any circumstances the shepherd must practise such disinfection as is practicable.

Septic inflammation may occur to the navel of lambs and lead to systemic infection. There is no doubt an organism is responsible for this disorder, which gains access through the unclosed navel; the affection is a most serious one in a lambing flock. It should at once be met by the lambing-pen being broken up and a fresh site found, isolation of the affected, destruction of the carcasses by fire or deep burial, and the adoption of the group system, a separate attendant being told off to each group of ewes and lambs. Cleanliness of the ground must be observed, the frequent use of disinfectants on the floor of the lambing-pen is essential, and all soiled litter must be destroyed by fire. The shepherd is the most important person to look to and disinfect; overall clothing should be provided, and a rigid disinfection of hands and nails made, under competent supervision. This should be carried out with hot water, soft soap and a scrubbing brush, repeated until the dirt has apparently gone; then followed by washing in alcohol and ether, finally scrubbing in bichloride of mercury (1-500). If the disease continues the shepherd must suspend operations.

This disease can be got rid of by surgical cleanliness, which is a difficult thing to thoroughly apply where all facilities exist, but is intensified where the work is being done in a field, with few appliances, and unskilled and passively obstructing labour.

What is true of 'Navel Ill,' as it is called, is equally true of parturient septicæmia in the ewe. Look to the accoucher, he is the source of infection and its chief method of spread. No matter how far the soil and surroundings are responsible for the first case, it is the hand of the shepherd which completes the evil.

The same measures must be adopted in parturient septicæmia as in other bacterial infections. Isolation of the

affected, introduction of the group system so as to reduce the chance of spread, removal of the lambing-pen to fresh ground, destruction by fire or deep burial of all membranes, fœtuses, dead ewes, and soiled litter. The liberal use of disinfectants on the ground, and to the hands and clothing of the attendants; fresh overall clothing must be used daily, and a system established of never touching a ewe until disinfection of the hands in perchloride has been made. Such are the measures of stamping out the disease; the degree of success can only be measured by the thoroughness with which they are carried out.

Infective mammitis of ewes is a microbic affection fortunately rare in this country. It has been said to be infectious from cows to ewes, and that the latter have contracted it from lying on litter soiled by cows. However conveyed, the organism no doubt gains access to the gland through the teat canal, and the usual symptoms of mammitis are present.

Isolation of the affected ewes is of the first importance, a fresh man must be put in charge of the cases, in order to prevent carrying infection to the other ewes. Disinfection of the ground must be practised, and soiled litter burned or buried.

There is a form of sporadic mammitis which, though troublesome and destructive, is not infectious, it is of interest from a hygienic point, as one of its supposed causes is chill due to the clipping away of wool from the region of the udder.

*Clipping.*—The object of this clipping, known by various provincial names, such as *clatting*, *underlocking*, etc., is to remove soiled wool from the udder, especially in the long-wool breeds of sheep, in order to prevent the lamb from taking this wool into its stomach, where it forms an obstruction. As a hygienic proceeding clatting is very necessary, for wool balls in the stomach of lambs are a very common cause of death among long-wool breeds.

Another cause of wool balls is the animal tearing out its own wool due to the irritation caused by parasites. The

prevention of this may be brought about by the dipping of ewes in the autumn, for it is obvious the parasitic infection of the lamb is derived from the ewe. The use of poisonous dips on ewes which have lambs still running with them must be carefully carried out, or the lambs may be poisoned by sucking the wool.

The clipping of wool from around and beneath the tail of ewes is a sanitary precaution in the long-wool breeds which should not be neglected either in the pasture or the lambing-pen.

The *Castration* and *Docking* of lambs are frequently carried out at the same time, and generally a few days after birth. Of the advantage of docking and its hygienic necessity there can be no doubt. A long useless tail has been provided the sheep, which soon becomes in a most filthy condition, and leads to the disease known as 'maggot,' described at p. 432.

Parasitic attacks to which sheep are liable are described elsewhere. Foot-rot has also been dealt with, but it is here necessary to draw attention to the fact that there is a variety of foot disease in sheep often mistaken for foot-rot, which is not contagious but due to neglect.

*Neglected Feet.*—The feet get overgrown, especially on wet land, and the horn becomes curled or twisted. Dirt and gravel work up between the wall and the laminae, and set up suppuration.

The preventive measures are very simple. Long feet should be at once attended to, and reduced to a proper length by means of a knife. Regular inspection of the feet should be made from time to time for horn separations, and burrowing dirt and gravel.

In some flocks the sheep are regularly passed through a trough containing a disinfectant, and afterwards folded on a surface like a hard road until the parts are dry. This is done to prevent foot-rot, a disease which is specific and quite distinct from the above; but there appears no reason why on pastures liable to produce non-specific foot-trouble this method should not be adopted as an

ordinary routine, combined with the individual inspection of feet.

*Dipping* and its principles have been dealt with at p. 422, but it may not be amiss here to draw attention to the question as a routine of flock management, both of preventing fly attacks and acari.

The dipping time varies, depending upon the part of the country, while many flock masters never dip. Dipping in the autumn is perhaps the more common practice, though in Scotland it is not done until as late as October or November. In some parts two dippings a year are practised, viz., after shearing, and again in the autumn, and this practice is rational and recommended. Lambs may also be dipped twice a year, which is the custom in some localities, but neglected in others.

The care to be taken in dipping, and the agents employed, are fully dealt with at p. 422.

#### PIGS.\*

The pig gives less trouble to manage than any other animal of the farm, and yields an excellent return, for there is no animal that puts on so much weight for a given weight of food, and none where early maturity can be so readily practised.

The only period, in fact, in the life of the pig where any anxiety arises is just after weaning; but there are few of the dangers of parturition as in the sheep, seldom any after-effects as in the cow, while the digestive system can accommodate itself to the most varied diet, and continue to turn it to useful advantage. The weak point about the pig appears to be his susceptibility to cold, which is much more marked than in the case of cattle and sheep.

\* This article is based on 'Pigs, Breeds and Management': Mr. Sanders Spencer, *Live Stock Handbooks*, No. 5; 'The Complete Grazier,' Dr. Fream; 'Breeding and Management of Pigs,' Mr. Howard, M.P., *Journal of the Royal Agricultural Society*, vol. xviii., part i, 1881.

*Feeding.*—The question of feeding may conveniently be considered with the pregnant sow, which unlike the ewe requires during the last month to be kept in better than store condition, owing to the drain of from fifteen to twenty fœtuses which require nourishment. The food during the fourth month should be nitrogenous rather than fatty: barley, wheat, maize, and peas, in the form of a meal fed as slop night and morning. It is here important to remember that even in this matter breeds of pigs vary. The better bred pig is less tolerant of a rich stimulating diet than one of little breeding; in the former the rich milk appears to react unfavourably on the progeny, so that indigestion and diarrhœa are said by men of experience to follow on its use, while this is not observed to follow with underbred pigs. Spencer tells us that so much is this the case, that he has for many years ceased to give barley or other meal to suckling sows until the pigs are at least a month old; in the meantime they receive twice a day sharps and bran, as much as they can clear up at once, and a month after farrowing a little meal composed of wheat, barley, maize, and oats, given three times a day, while a grass run and food like tares, lucerne, etc., are invaluable.

The winter feeding in the absence of green fodder is generally kohl rabi passed through a cutter. This is followed by mangels, while as the spring comes on grass is once more available. Cabbage is given frequently, but Spencer tells us it is liable to produce constipation.

During the winter beans or maize both crushed as a meal may be given.

After farrowing the food of the suckling sow may be gradually increased, and she should daily be permitted to take a turn in a grass field for an hour or so, as a relief from her family, and a means of assisting the action of the bowels and bladder. It also affords an addition to her diet of green stuff, and enables her to take such earth as she requires.

The litter should be encouraged to pay a visit to the

dam's trough, for when they are capable of taking some solid food the drain on the sow is greatly reduced ; later on, a special supply of food for them may be given, consisting of sharps or oatmeal stirred with milk, or a mixed meal of oats, peas, or wheat, with water, mixed with skim milk or whole milk when it can be spared. During the winter this material should be raised to blood-heat, to economize the body heat of the young animals.

*Weaning* may be carried out at eight or nine weeks, and is gradually brought about by allowing the dam to remain longer from her offspring during the day until final separation occurs.

Spencer is very clear over the harm which young pigs may suffer at weaning time through injudicious feeding ; they require little and often, three or four times a day. In the winter their food should be given warm, but the greatest care must be taken that food too rich in character is not given them at once on separation, under the mistaken idea that as they are not getting their dam's milk their hand feeding should be more nourishing.

It is at this time that under such treatment certain disorders of digestion appear, accompanied by fever, constipation, and finally diarrhoea. Their food need not differ in the first instance from what they were receiving before weaning, with the exception that some pea-meal may be added ; at three months old they may receive one-sixth of barley-meal, which is gradually increased until it becomes two-thirds of the diet in a pig of five months. Howard recommends sharps, bran, and barley-meal, with dust of linseed cake scalded with boiling water ; it is allowed to stand twelve hours, and given with warm water and milk. As the young animals advance some pea-meal may be given in addition at mid-day.

*Fattening of Pigs.*—In the fattening of pigs, as in that of other animals, they should never be allowed to lose condition ; they must always be kept in a progressive state, as young flesh once lost is always most difficult to replace. Variety in diet is essential, a mixture of meals is always



better than feeding on one particular kind, but the mixture must be judicious; maize, for instance, can be used in the earlier stages of fattening, but only in small quantities towards the end, as it renders the flesh yellow and flabby. Pea- or bean-meals are good for older pigs, and produce a firm flesh, though in excess they cause it to become hard and stringy. Oatmeal is very valuable in forcing young animals for an early market, while barley-meal is the best single meal which can be given.

No food must be permitted to remain in the troughs. Howard only allows troughs to boars and invalids; the others are turned out by pens into a yard to feed; if this system is adopted, it must be carried out regularly and systematically.

Howard recommends for fattening pigs a mixture of equal parts of bean, maize, and barley meals; to three parts of these is added one part of sharps, and if forcing is required a little linseed cake is added in a scalded condition.

Cooked food for pigs is not recommended by the best authorities, as it causes considerable loss in digestion, though if potatoes are given they are best in the cooked state.

The swill-tub is a permanent institution in pig-feeding, where all sorts of kitchen and dairy refuse finds its way; among the latter whey and skim milk are extensively used in pig feeding. The swill-tub has frequently been the cause of death owing to the contents of the brine-tub finding its way in, and producing poisoning (see p. 195).

Pigs that are not allowed a run abroad, require a certain amount of earth or cinders to be provided; but all stock pigs should be allowed exercise daily to keep their limbs and feet in order, and to regulate their bowels and bladder.

Show pigs are sometimes ball fed, which process is carried out after the usual thinner trough food, by means of balls the size of an egg, composed of mixed meal and milk. These are offered to the pigs after being dipped in

new milk, and a gallon of balls may be disposed of by each pig at a sitting.

Green food must not be neglected, it is imperative for fattening as well as other animals; grass, clover, lucerne, kohlrabi, turnips, cabbages, and cooked potatoes may be given. Pigs in their natural state freely partake of grass, roots, acorns, chestnuts, etc., and in the days when they were kept for a year before fattening was started, this method of feeding was adopted, but is now replaced by that of early maturity.

Acorn poisoning with pigs is due to excess, and is a well-known cause of trouble, especially during years when crops fail.

For further remarks on the feeding of pigs, see pp. 132.

*Piggeries.*—The construction of the piggery has been dealt with elsewhere (p. 345). Warmth and dryness are necessary, for pigs are very liable to rheumatism. Cleanliness is an essential where pigs are kept under artificial conditions, and is insisted upon in well-ordered establishments devoted to pig rearing. Ventilation and light, especially sunlight, are important adjuncts to health.

*Farrowing.*—A week before the time of farrowing is due, the sow should be placed in the sty she is to occupy, and some short straw given her to make her bed with. Long straw should not be used as it sticks to the eyes and nose of the young pigs, and winds round their legs; in this way it prevents them escaping being crushed when the dam lies down.

After farrowing food must be given sparingly for two or three days, and then consist of sharps and bran. A little exercise must be given the dam to assist the evacuations.

It is generally considered that a dam at the first farrow should not be expected to bring up more than seven or eight pigs, and not more than ten or twelve at subsequent farrowings. Numbers in excess of these are too great a strain on the maternal resources.

No sucking is permitted until confinement is complete, in the meantime the new arrivals are dried and placed in

a basket for warmth. After the placenta has been removed, in order to avoid the sow getting to it, the young pigs may be introduced to the dam and the udder emptied.

It may be necessary to remove the little black teeth some pigs are born with, and the existence of which is so painful to the dam in sucking that she refuses to allow access ; these should be broken off with a pair of plyers.

*Boars* should not be taken into service until eight or nine months old ; they must have exercise to keep the legs and feet in order. Both boars and sows must be treated gently, in the case of the boar his future temperament will depend upon his management and treatment when he is first used. Sows should not be used for breeding purposes until they are eight or nine months old.

#### DOGS.\*

The breeds, varieties, and uses of dogs are so many and different, that we can only touch upon a few general principles here, and refer the student to the works of specialists, and the literature of the so-called breed societies. The management of hounds, or of dogs used for sport, will necessarily differ from that accorded to the toy or fancy varieties, kept merely as pets and sharing the owner's home and many of his habits.

The diseases from which they suffer are largely preventable, if fed upon suitable food, given adequate exercise, and not indulged in luxurious habits, or made to suffer hardships when employed for sport or purposes of draught. The period of greatest anxiety is that from three to eight months of age, when distemper is most likely to affect them. The fancy varieties are liable to abortion, and all breeds to septic pneumonia, an infectious gastro-enteritis, to a great variety of entozoa, and to acari. The malady most to be feared, because communicable to man, and fatal

\* I am indebted to Mr. H. Leeney, M.R.C.V.S., for kindly contributing this section on the Care and Management of Dogs.

in its results, is rabies; happily (at the time of writing) extinct so far as the British Islands are concerned.

It may be said that dogs suffer from most of the diseases of the human subject, and that they are largely preventable. Rheumatism is common to the hound and gun dog, as the result of excessive exertion, long fasting, and lying down when wet upon cold and damp floors, or on the natural earth; and to the pampered pet, in which it takes the form of rheumatic gout, and would appear to be influenced greatly by retarded metamorphosis of tissue, or the presence of uric acid in excess of what the excretory organs can deal with.

*Feeding of Dogs.*—During the first month all the necessary aliment is supplied by the bitch, and the general custom among breeders is to wean at six weeks, a little farinaceous food having been offered during the final week or ten days. Economic reasons, however, will influence the breeder; the number of puppies may prove too serious a drain on the mother, and parturient eclampsia be the penalty incurred, or the conversion of her tissues into milk for the offspring may so reduce her as to preclude any hope of prize-winning at shows, for which she has already been entered and for which a fee has been paid.

So great a value will often be attached to a puppy that failing a foster-mother it will be brought up by hand almost from birth. Reference to the analytical tables showing the composition of milk will tell us that the bitch's milk is richer than all the other domesticated animals save in milk-sugar, and that the sow alone has more salts. The food best suited to hand-reared puppies or for those weaned early, is bread and cow's milk, with the addition of cane-sugar and lime-water. It should be given at the temperature of the body or a little over. They should be fed four times a day at first, and allowed to eat to repletion, after which they will sleep, wake up and play, and again seek food, as is the case with most young creatures.

Very young puppies should be fat and have the appearance of little pigs, if thriving well. From about the age of

ten weeks, a bread-and-milk diet should gradually give way to more substantial food, as oatmeal porridge and thin biscuits, fed dry, but not too hard to be dealt with by the temporary teeth. Ellenberger and Hofmeister have come to the conclusion that rice and milk are chiefly digested in the intestines, and that the rapidity with which the dog swallows his food precludes any sufficient action of the saliva to make the required change in the starch; hence it is desirable as the animal grows older to give such a proportion of dry food as will compel him to masticate and insalivate it, thereby developing his digestive powers for a mixed diet in adult life.

Quite the majority of puppies acquire nematode worms during the first four months of life, and breeders commonly drench them with santonine and castor-oil, or cascara sagrada, syrup of buckthorn, or other simple vermifuges, as soon as any check to development is observed. The exceptions to this rule are to be found among those whose object is to produce the smallest animals and the survival of the unfittest.

As to the feeding of dogs when adult, there is great variety of opinion and practice, it being held by those who consider the dentition as indicative of the food that should be given, that meat should form a considerable proportion of the ration, while those who desire dogs for their companionship chiefly, would confine them to a diet almost exclusively farinaceous. Hounds and hunting dogs are generally fed with oatmeal porridge, with various proprietary biscuits, and with the flesh of horses and cattle which have been killed on account of some infirmity, or died of disease. The fitness or otherwise of the latter is usually decided by the huntsman, and ill consequences are but rarely traceable to such food. The amount of flesh food allowed will bear some relation to the work required, and the keenness of scent; it being generally thought that dogs have a keener olfactory sense when not debauched by flesh food in abundance.

The dog is a most accommodating animal in the matter

of food, and will thrive on almost any diet if changes are not too suddenly made. The large amount of hydrochloric acid present in the stomach, enables him to deal rapidly with flesh food, and experiments conducted at the St. Petersburg School prove that the digestion of meat is very much more rapid than that of hydrocarbonaceous food, while the proportion of acid and of peptones varies with the individual's requirements. A number of dogs were subjected to experiment at the above-named school; the œsophagus being divided and secured outside in such a manner that food masticated was gathered in a receptacle as deglutated, while the gastric fluid was at the same time withdrawn and tested. It was assumed that, what we have already referred to as the accommodating nature of the dog led to altered secretion, and that progressively, when a change of diet was made, but the experiments proved that the proportions were influenced while yet the food was in the mouth, and that the stomach received some intimation of what to expect.

Digestive disturbances in dogs frequently lead to eczematous eruptions, and it is often found that a sudden and complete change from biscuit to flesh, or flesh to biscuit, is all the treatment required. It may be remarked here that dog biscuits, as sold by the chief manufacturers, contain a portion of exhausted flesh, the residue from factories where meat essences are made for human consumption, but that the processes employed are so efficient as to leave little but fibre and insoluble débris of no great food value, but having some slight taste and odour of meat attractive to dogs. That dogs thrive for years on this food is not open to doubt, but that a majority, said to live exclusively upon it, obtain table scraps, or forage for themselves when at liberty, is the general experience of canine surgeons.

As in the character of the food upon which dogs will thrive, so in the matter of hours of feeding; any habit may be established without apparent detriment to the animal's health. Many dog-keepers feed only once a day, and perhaps the greater number of these give the meal in the

middle hours of the day. Others, for their own convenience, and to prevent hungry dogs from howling at night, feed them in the evening. A dog will eat enough at one meal to keep him in health, but he will enjoy a higher level of comfort if fed twice a day. If it is desired to put flesh on a wasted dog, it is doubtful if more than two meals in the course of one day can be given with advantage, but most dogs will gain weight very rapidly if fed at nine or ten a.m. and at five or six p.m. For this purpose a mixed diet will produce the best results, and the meat portion should be cut up into very small pieces, and so mixed with porridge or other food that it cannot well be separated by the animal, who will soon acquire a preference for flesh food, and finally eat nothing else if he can obtain as much as he wishes.

House dogs too generally receive an excess of bones; they are particularly fond of them, and there is no other use for them in the domestic economy. They are crushed and swallowed unless very large. The gelatinous portion is digested, and the insoluble mineral matter accumulates in the terminal portion of the intestinal canal. The white hardened fæces, which crumble when trodden upon, are almost exclusively composed of this material. Apart from the risk of splinters of bone becoming lodged in the œsophagus, or some other portion of the tube, and of constipation when an insufficient proportion of laxative food is allowed, there is no great objection to bones, having regard to the peculiarities of the species in the matter of defæcation. Unless the excrement is hard, the anal glands are not called into play; they suffer congestion for want of the pressure exerted in the passing of hardened fæces, and little abscesses follow on the habit of drawing the anus along the ground to relieve the itching—caused by the congestion.

The fæces of a healthy dog should be hard, and there should be some posturing and effort to expel the first portion, the remainder coming away quite easily when the unctuous secretion from the glands has lubricated the fæcal substance.

*Exercise* is essential to the health of these animals, and many retain the excrement until they have had a gallop. Those unfortunate individuals doomed to be chained up as watch-dogs should be fed on wet biscuits, as these are laxative when fed wet, but not so when eaten dry; as with wet or dry bran when fed to horses.

*Water*.—A fresh supply of clean water should be within reach, but it will be observed that dogs seldom drink when chained up or confined in a kennel. If let off the chain or freed from confinement they will drink immediately on their return, although they may not have travelled a dozen yards. No dog will grow fat unless he drinks freely. The time-honoured custom of placing a roll of sulphur in the drinking trough is quite harmless; it is very insoluble.

*Housing*.—Dogs belonging to what may be called the useful breeds, as distinguished from the delicate fancy animals who share the owner's rooms, may be trained to sleep in a kennel outdoors all the year round and in any climate. They will make a bed in the snow and rear healthy whelps, or through pampering become so tender as to need a basket sheltered from the draughts of an ordinary living room. As bedding material pine shavings are preferred as inimical to fleas. It need hardly be said that changes should be made gradually if habits are to be altered. Kennels outdoors should always be provided with a wooden platform. In confined yards one or more posts should be erected, or male dogs will not urinate as freely as is desirable. In this matter also they are creatures of habit, and of man's convenience. If early trained to retain urine, they will suffer greatly rather than offend, and will learn to evacuate the bladder by one or two efforts when turned out for the purpose, but their natural habit is to pass small quantities and at many places. Bitches more frequently empty themselves by one or two efforts, and do not appear to find smelling at posts necessary as male dogs do.

*Washing*.—It is occasionally necessary to wash dogs, but is a practice which leads to many troubles. The white-haired varieties, kept as pets, cannot well be kept clean



without a bath at comparatively short intervals, but the custom of employing so-called dog soaps is responsible for much scratching and discomfort to the animal.

These soaps are destructive of the natural oil in the coat and integument, owing to the excess of alkali they contain. The skin is left dry after their use, and there is a disposition to desquamation of the cuticle. A habit of scratching is often due to this practice of washing in the first instance, but commonly attributed to ennui. If it is absolutely necessary to wash dogs, a superfatted soap should be employed, or the yolks of eggs, and to the final rinsing water some five per cent. of glycerine may be added.

When a dog is to be washed, he should be made to stand in a large bath, and his face, ears, and neck, first wetted with water not much above the temperature of the body, as these animals do not bear hot baths well, and have been known to faint in water not nearly so warm as might be agreeable to the human subject.

Beginning at the face, and working backwards with the soap or medicament, insures the destruction of ectozoa which otherwise take refuge around the eyes and ears, a few pregnant females escaping and sufficing to reinfest the host. No drying with towels should be deemed sufficient, but exercise enjoined until the coat is thoroughly dry.

Many dog fanciers keep their dogs clean without washing; simply rubbing into the skin a quantity of finely-powdered fuller's earth, and subsequently combing and brushing.

*Docking.*—The practice of docking certain classes of dogs has no hygienic justification such as may be claimed for sheep, but is purely a matter of fashion, as was the clipping of ears in a former generation.

*Worming.*—Under the tongue is a 'remarkable fusiform mass apparently of cartilage,' and the removal of this, under the impression that it is a worm, is a barbarous practice still carried on by ignorant dealers in dogs. It was advised also 'to prevent them going mad' and in-

identally to hinder, by the soreness of the tongue, the disposition of mischievous puppies to destroy carpets, slippers, etc., within reach.

*Ingrown Nails.*—Working dogs, and those enjoying abundant exercise, wear down the nails to a convenient length, but pet animals living very much in carpeted rooms, suffer from overgrowths necessitating periodic shortenings with scissors made for the purpose. Those nails upon the so-called dew claws grow in a circle, and if not shortened, as above advised, eventually pierce the pad. The vascular and sensitive portion of the nail grows in correspondence with the insensitive, and cutting back is a somewhat painful operation if long neglected.

*Canker of the Ears.*—Several forms of irritation in the meatus, and generally termed 'canker' by dog owners, are largely preventable by simple measures, such as the introduction of a little camphorated oil at night, followed by a careful syringing next day to remove the dust and debris which is specially noticeable in dogs allowed to follow carriages. The presence of a symbiote (*Symbiotes auris canis*) in the meatus is a frequent cause of itching, and the condition known as canker results from the animal's own efforts to dislodge him by striking the base of the ear with the hind foot. Serous abscess occurring between the inner reflection of skin and the cartilage of the flap of the ear is often the result of shaking the head violently when annoyed by the parasite above mentioned.

*Mange.*—Immediate isolation of infected subjects is important, as the acari are readily transferred, and in the case of long-haired dogs not easily eradicated without clipping and consequent disfigurement for a long period. A 4 per cent. creolin lotion is a safe and effectual remedy, and should be repeated at the time when a second brood may be expected.

*Distemper.*—It is to be regretted that up to the present time no real prophylactic has been discovered, nor does it seem at all clearly proved to be due to one specific organism. Dr. Phisalix claims to have isolated the bacillus and made

successful cultures, but the so-called vaccines, prepared under his directions, failed to satisfy a commission of experts who conducted a series of experiments upon puppies brought to London for the purpose, and placed under as favourable conditions as could be obtained. Professor McFadyean and the majority made a report in which they gave it as their opinion that the Phisalix vaccine did not afford any protection. Mr. Henry Gray, representing a minority of two, made a report in which they stated that the test was not a satisfactory one or carried out in a trustworthy manner, and therefore inconclusive. On the Continent of Europe distemper vaccines enjoy a considerable reputation.

## CHAPTER XIV

### HYGIENE OF BREEDING\*

THAT 'like produces like' is the fundamental principle which underlies all breeding, and it is on the intelligent and long-continued application of this principle towards a definite end, that the breeder depends for his results. The science of breeding is a most complex one, and in order to insure success the breeder must direct his careful attention to a variety of points which might at first sight appear to have no immediate bearing on breeding.

*The Breeder.*—Before going further we will first consider the personal equation of the breeder himself. A breeder to be successful must be possessed of considerable patience and tenacity of purpose, as he will have to put up with numerous disappointments as time goes on. He must be an enthusiast, with a thorough knowledge and keen love of the class of animal he elects to breed, and should be able to communicate some of his enthusiasm to his men. This last point is of importance, as a good deal of the breeder's success depends on good attendants, a fact which we think is often not sufficiently recognised at shows and in the distribution of prizes. We think that a certain amount of

\* This chapter is from the pen of Captain Olver, Army Veterinary Department, whose opportunities for studying the question were obtained with his father, the noted breeder of Trescowe, Cornwall. The principles of breeding here formulated are those gained by this family during two generations.

I desire to record my indebtedness to Captain Olver for his valuable assistance.

the prize money should always go to the man who has prepared the animal for show.

The breeder's success will also depend to a large extent on the possession of that more or less innate faculty for the selection of breeding stock and successful mating, which is known as the 'breeder's instinct.' This faculty is not possessed by all alike, and is probably to a certain extent inborn, but must always be based on a thorough knowledge of the animal, a feature which can, of course, be very largely cultivated. In addition, the breeder will require to have a thoroughly practical knowledge of farming and the management of grazing land, and of the care and feeding of stock at all ages and times.

Without this knowledge and the careful application of it, his efforts will constantly be counterbalanced by the unfavourable conditions under which his stock is reared.

A certain amount of capital will be required to obtain a good foundation for his stock, but money alone will not insure success without the above-mentioned qualifications.

Finally, the breeder should keep careful records of all pedigrees and the results he obtains, as in this way only can he avail himself to the full of the experience gained.

*Suitability of Locality and Climate.*—The next point requiring most careful consideration is the suitability of the land and climate to the particular classes of animal to be raised on it.

It is quite useless to attempt to produce the best of any class of animal on land and in a climate which is not completely suited to it, unless the system of breeding is to be an almost purely artificial one, in which case the expense will be excessive and quite impracticable for any but the most expensive classes of stock, such as race-horses and show animals.

Under any circumstances, this artificial system of breeding is not to be recommended, as it always has an ill-effect on the constitution of the stock as a whole. Before commencing operations, then, the breeder should take every

precaution in his power to insure that he obtains this complete suitability of stock and land.

In making his selection, he should be mainly guided by the reputation of the farm and district for the various classes of animals, and by the experience of the residents of the district. He should not attempt to fly in the face of the predilection of certain classes of stock for certain places for the sake of a strong fancy for some particular breed which is not so eminently suitable, as disappointment can be the only result.

Throughout the world there are certain farms, districts, and countries which have earned a reputation for producing certain classes of stock to perfection, often in spite of the utmost carelessness in breeding. This is due to the exceptional suitability of these places to the particular class of stock raised, and is well instanced in the predominance of Ireland in producing all classes of light horses.

Attempts may be made to supply the deficiencies of the soil by artificial means; for instance, on some farms which do not produce sufficient bone of the right class, owing to a lack of lime-salts and phosphates in the soil, phosphates and bone-meal may be supplied to the young stock from an early age, but the result, in our experience, has never been satisfactory, and often not appreciable. It would appear to be necessary to present the required salts in their natural condition in the food and water in order to produce the desired result.

As a very marked instance of the effect of the influence of land and locality on the stock raised on it, we would point to the marked difference in type between the North Devon breed of cattle and the South Devon or South Ham breed, sometimes also called the Somerset Devon.

There is every evidence that these two breeds originally sprung from the same stock, but owing to the marked difference in the character of the soil on which they have been raised for centuries, they have now become widely different in type, although retaining the same colour and

markings. The North Devon having been accustomed to rather a light, poor soil has itself become small and light, but shows great quality and milking character. The South Devon, reared on the very rich land of South Devon and Somerset, has become very much bigger and more massive, and of a coarser type generally. It is never sound policy to rear these South Devons on light land which will not 'carry' them, as they very soon lose their massive character, and tend to become light-fleshed and bony without the quality of the North Devon.

The difference of type between mountain ponies and cart-horses bred on the fens will also serve to illustrate the point, although a very extreme case.

Whether the system of raising the stock is to be a natural or a purely artificial one, the climate, aspect, and natural drainage of the farm must be taken into account. Every class of animal has a preference for a certain climate—aspect, for instance. Sheep as a rule prefer a high situation and dry atmosphere, with a light, well-drained soil, while cattle prefer a lower position, with deep, rather moist soil which will produce the richest herbage.

Then, again, the different breeds of each class of animal vary very much in this respect; for example, heavy shire horses can be raised with success on the Lincolnshire fens, while light, well-bred horses require a lighter and dryer soil, with a much warmer aspect.

*Suitability of Surroundings.*—All young animals require plenty of fresh air and sunlight, with sufficient exercise for their best development, and these must be assured them if success is to be obtained.

All boxes and houses should be dry, airy, sunny, and should stand on a well-drained soil, gravel for preference; any tendency to dampness or mouldiness should be avoided. They should have a southern aspect, and, if possible, an open court in front where the animals can remain during the day, and get a certain amount of natural exercise and sunlight.

While on the subject of the boxes, stables, etc., of a

breeding establishment, it may be mentioned that the floors, walls, mangers, etc., should be so constructed that they can be easily cleansed and disinfected, if any infectious disease makes its appearance.

When the system of raising the young stock is a natural one, so that they spend most of their time in the open all the year round, the composition of the fences is of great importance. Although good sheds may be provided and the animals fed in them, they will seldom make use of them for protection, even in the most inclement weather, but prefer to take shelter under a fence, so that these should be high and thick enough to afford sufficient protection. This does not apply to sheep, which always turn their backs to the storm and go in front of it to the most exposed position they can find.

It will probably be necessary to provide a certain number of foaling and calving boxes; lambing pens can be extemporized, but we do not advise the construction of any special place for the confinement of the animals except in extreme cases. The open field is the natural place for animals to be delivered of their young, and it is wonderful how little harm they suffer, even in the most inclement weather. We are satisfied in this matter that by far the best results will be obtained by adhering to natural conditions. We are very much more afraid of infection in the common foaling box or lambing pen than of the effects of the weather. If foaling boxes are used, great care should be taken in their disinfection after every parturition, and for this reason the floors and walls should be as impervious to moisture as possible, and lambing pens should be frequently moved. Common foaling boxes are held responsible for the spread of several diseases of breeding and young stock which are the source of great loss every year. Some of the most important are: Septic metritis, navel ill and white scour in calves, which are fully dealt with elsewhere.

Another reason why pregnant females are better in the open at the time of and before parturition is that they are then able to obtain natural exercise and what green food is



available, and will be less liable to complications in consequence.

All animals at this time are naturally shy, so that they should not be interfered with unless it is absolutely necessary. It is a good plan to have a small peep-hole in the door of a foaling box, so that a valuable mare can be watched without attracting her attention.

*Water-Supply.*—The question of water-supply on a breeding farm is also of great importance. As far as possible, a supply of good running water should be available in every field. Stagnant water forms an excellent breeding place for all sorts of parasites, and should in consequence be carefully avoided. In some places there is a common idea that sheep do not require water every day, if being fed on succulent herbage. This, we need hardly say, is an entirely erroneous idea, and the difference in the condition where an ample supply of water is available is very marked.

Before leaving the question of the farm, we would emphasize two points—viz., the necessity of maintaining the land in high condition, if the best results are to be obtained, and the value of scientific and thorough grazing. The class of stock on the grazing land should be constantly changed, or it will become 'sick' of the particular class of stock kept on it, and all tufts of old grass should be eaten off before the winter, as they harbour ticks, which are important carriers of disease—for instance, Red-water.

*Selection of Type.*—We now come to the consideration of the points which are more directly concerned with breeding itself.

The breeder, having selected the breeds which are most suited to the land and district, should then lay down for each the exact *type* he aims at producing. For instance, among cattle he may select the 'beef,' or 'milking,' type, or may aim at a general purpose animal with both qualities developed to a certain extent.

Among horses he may select the thoroughbred, the hunter, the polo pony, the hackney, the shire horse, etc.

Among sheep he may select an essentially wool-pro-

ducing variety, or if he intends to raise early lambs, one noted for its early maturity.

In selecting his type he should follow the natural tendency of his land as far as possible, and must remember that it is not possible to obtain the highest point of perfection in every respect in one animal; for instance, among cattle, if the beef-producing type is developed to its highest point it is almost certain to be at the expense, more or less, of milking qualities. In the shorthorn breed an attempt has been made to combine the two qualities in one animal, but among them certain families and herds are noted for the beef-producing character and others for the milk-producing.

This definite laying down of the type to be aimed at is of the utmost importance to successful breeding. The improvement obtained will always be very gradual, and must depend on continuous breeding towards the same end. By this means the desired type will in time become firmly stamped on the stock as a whole, a result which can never be obtained if frequent changes of policy are permitted, or if breeding is carried on in a haphazard way without a definite aim.

The advantage of firmly fixing a type on the stock is that the breeder can count with tolerable certainty on the constant reproduction of that type, whereas, with less carefully bred stock, the results will always be more or less a lottery.

If a distinct variation from the established type arises it should not be bred from, however excellent in other respects, or the liability to variation will be perpetuated, and is a most objectionable characteristic.

*General Principles of Breeding.*—We are now in a position to consider the general principles on which all breeding is based.

The one fundamental principle is that 'Like produces like,' but in its practical application the breeder must make certain reservations which are the result of long experience. The first of these reservations is that although well-bred animals of long and good pedigree can be depended on with

great certainty to reproduce their like, the same cannot be said of animals which have not the advantage of this long and careful breeding.

This explains why representatives of a newly-formed breed, or 'chance' animals, however good in themselves, so frequently fail to reproduce their type. They are quite likely to throw back to some ancestor of quite a different type. Provided that the breed has not become effete, it may be taken as a rule that the longer and more carefully any class of animal has been bred, the greater will be its *prepotency* or certainty to reproduce its type, so that pedigree is a most important point for consideration in the selection of breeding-stock.

The second reservation we would make is that it is never safe to mate animals of widely different types in the hope of striking the happy medium between the two parents in the offspring. It is much more probable that the result will be a bad representative of one type or the other, or a throw-back to a remote ancestor of one of the parents of quite a different type to either. If it is desired to modify an existing type the process must be a gradual one, so that the alteration becomes stamped on the stock as the change takes place by slow degrees.

It follows from the above that the breeder should only select his stock from well-bred animals of long pedigree, and should aim at close uniformity in type. Any marked variation from the desired type should be rigidly rejected, however excellent in other respects, otherwise annoying variations will be liable to crop up at any time and destroy the reputation of the stock for their true-breeding qualities.

These last remarks apply more particularly to breeding from representatives of well-established breeds.

If, on the other hand, the breeder aims at producing an entirely new breed from selected animals of various breeds, he will require to resort to inbreeding to counteract this tendency to uncertainty.

By inbreeding is meant the mating of closely related animals of the desired type, a sire not infrequently being

mated with his own daughters, provided that they show the desired type.

This system has been much resorted to in the formation of new breeds, and reduces the liability to variation to a minimum, as the blood of both parents is almost the same.

The offspring of such a union is usually exceptionally good looking and full of quality, but there is always a strong tendency to weakness of constitution, and if the system is persisted in over a number of generations the stock will become quite effete, and the females either refuse to breed or produce a large proportion of weedy or malformed animals.

When this system of inbreeding is resorted to, every endeavour should be made to counteract its enervating tendency by rearing the young stock under the healthiest and most natural conditions possible.

Among shorthorn breeders, who had recourse to this system very largely in establishing the breed, attempts were made to obtain exceptional vigour of constitution in the sires by sending them away for a season or two to a totally different climate to that in which they were reared. A well-marked instance of the influence of inbreeding is seen in the 'Snorer' family of polo ponies, in which the type was reproduced with remarkable fidelity.

*Unsoundness.*—In nothing is the maxim that 'Like produces like' more certainly borne out than in the transmission of the tendency to unsoundness, so that the breeder should be most particular only to breed from absolutely sound stock. By soundness we mean not only soundness of wind and limb, but also of constitution. Among horses there are certain well-accepted hereditary unsoundnesses which are laid down as disqualifying a thoroughbred sire from winning a Queen's Premium. They are as follows :

Roaring, whistling.	Navicular disease.
Ringbone.	Spavin.
Unsound feet.	Cataract.

An animal showing any of the above unsoundnesses should be rigorously excluded for breeding purposes, how-

ever good in other respects. We hold that it was a very good thing for the race-horses of England that Ormonde was sold out of England, although he was the horse of the century and had proved himself a prepotent foal-getter. He would have been mated with all the best mares in England, and, being unsound of wind himself, must have done incalculable harm to English thoroughbreds by transmitting a tendency to this unsoundness, which is, unfortunately, already only too common in England; in fact, he had already proved his prepotency in this respect among the few foals he got before leaving England.

In addition to the above there are many other unsoundnesses, qualities, and conformations which it is not desirable to reproduce, and which should, in consequence, be avoided in breeding animals. Among heavy cart-horses 'Sidebones' are of frequent occurrence, and should be carefully avoided in breeding stock, as they constitute a grave unsoundness in animals which are required for work on hard roads and in the streets; in fact, in all classes of horses any tendency to unsoundness or weakness in any part of the foot should be rigidly excluded. The old adage 'No foot no horse' should always be in the breeder's mind, as the best-looking horse in the world without sound, strong feet is quite useless for street work, and consequently will not command a high figure.

'Shivering' is another unsoundness of heavy coarse cart-horses which is very liable to be transmitted to the progeny. 'Splints' are a source of trouble in all classes of horses; they are nearly always to be found on the limbs of horses which have done much work, and may constitute a most serious unsoundness if they interfere with a joint or tendon. From the breeder's point of view they are of importance if present to a marked extent, as they are usually associated with a bad class of bone, or are particularly found in animals whose limbs are too light for their bodies and are consequently over-weighted.

'Curb' is an unsoundness which, from the breeder's point of view, is of considerable importance, as this sprain

usually occurs in weak, sickle hocks, which should be carefully avoided in breeding animals. Not only are they a source of weakness and mechanical disadvantage, but are also very unsightly and detract from the horse's value in consequence.

Before leaving this question of soundness we would emphasize the vital importance of strong, sound feet of the right class to all horses.

They should be of the correct size for each class of horse—*i.e.*, not too large and not too small. It is almost impossible to lay down any exact guide by which the breeder can be guided in determining when a foot is too big or too small, but he will learn by experience to judge in relation to the other parts of the limb.

We would rather see the feet a little too small than too big, provided they are of correct shape, have plenty of good tough horn, and that the smallness is not the result of contraction of the heels from old-standing disease of the foot. Such feet are usually associated with quality, and that hardness and toughness of the bones which is so much to be desired in all classes of horses.

The opposite class of foot—*i.e.*, a very big, flat foot—commonly has a bad class of horn, *viz.*, brittle, and weak, with fleshy heels and sole, which are very liable to bruises and corns.

Such feet are usually found in coarse, common horses of a very lymphatic temperament, and associated with a bad, soft class of bone.

We think that the fashion for very big, open feet has often been carried too far among fashionable shire-horse breeders, to the detriment of the breed. It should not be assumed because the heels tend to become high and narrow when the feet are chronically diseased that the exact opposite shape of foot, *i.e.*, a foot with particularly wide and rather low heels, is the ideal one.

Personally, we have rather a preference than otherwise for 'Donkey feet,' always provided that they are natural, *i.e.*, not the result of disease. Such feet are usually

particularly sound, hard, and tough, and associated with bone of similar class; some of the very best and soundest horses we have known have had a tendency to this shape of foot.

The ideal foot for every class of horse should be of medium size in conformity with the rest of the limb.

The fore feet should be almost round at the toe and should meet the ground at an angle of about  $45^{\circ}$ , while the hind feet should be more pointed and more upright. The heels of both fore and hind feet should be moderately wide, with well-developed frogs and strong heels, *i.e.*, the heels should not be too low and the horn of the heels and bars not too thin. The sole should be thick, well arched, and composed of good tough horn.

The horn should be thick, hard, and tough, and there is a very general preference for blue horn over white, white horn having the reputation of being weaker than blue.

Before leaving the subject of the correct conformation of the foot we would again impress on the breeder the vital importance of sound feet in horses of every class. We feel that it is not possible to emphasize this point too strongly, as no one but a veterinary practitioner of wide experience among working horses can realize its importance. Above all, the horn must be thick and tough, and animals which show any tendency to brittleness or thinness of horn or sole must be rigidly rejected for breeding purposes.

Deficiency of horn can be most easily detected by pinching the sole with a pair of farrier's pincers, while a thin wall is judged of when the shoe is removed. The great disadvantage of deficiency of horn, in addition to the liability to bruising in the case of the sole, is that in such feet the wall does not grow fast enough to keep pace with the damage done by the nails in shoeing. Consequently, the smith has difficulty in finding sound horn to which to nail the shoe, with the result that it is probably cast, and with it a large piece of the wall.

This want of sufficient growth is particularly noticeable in feet of this class in the very dry atmosphere of South

Africa, and great pains have to be taken to encourage the growth of horn as much as possible.

*Temperament.*—We have next to consider the question of temperament in its relation to breeding. Naturally, we would not advocate breeding from animals of very vicious temperament, but at the same time the greatest care should be taken to distinguish between high courage and innate viciousness, which we hold to be extremely rare in horses if they are well handled in their youth. Personally, we would much rather breed from a high-couraged animal which has resented ill-treatment in youth than from a phlegmatic animal in which no amount of ill-treatment would arouse any resentment.

Horses which are liable to show a little temper at times are usually exceptionally good workers, whereas the soft-hearted creature mentioned above, gives up when the slightest extra strain is put on him.

The animal to be avoided is the sulky one with an ugly head and an evil eye. Such are seldom good workers and can never be trusted.

We think the question of temper is of more importance in the female than the male, as in the former case the factor of evil associations will be added to that of heredity. Again, the temper of the sire, particularly among horses, is liable to be spoilt by a nervous or ill-tempered attendant. This is particularly the case among thoroughbred horses, and is almost certain to occur if the animal is used to 'try' mares for a more valuable stallion.

We have known several cases in which an entire horse has earned the reputation of being an absolute savage with one owner, while he has proved quite the opposite when transferred to more competent hands.

*Degeneration.*—Closely allied to unsoundness, and equally to be avoided in breeding animals, particularly horses, are certain conformations of the limbs which are recognised as being the result of degeneration. By degeneration we mean a tendency to fall away from the constructional lines which are recognised as being the



most advantageous, and to revert to a remote ancestor which has not had the advantage of improvement by careful breeding. This shows itself mainly in the limbs, which, instead of being so placed on the body that they look straight forward and can be carried forward in a straight line without any circular movement, are so placed that the whole leg looks outward, while at the same time the chest is narrow, and the quarters, instead of remaining square, become narrow from above downwards. The hocks are close together, and the hind feet and stifles look outwards.

A horse with this conformation of limb cannot carry his legs forward in a straight line, but must do so with a circular movement, which is a direct waste of power, and, in addition, is very liable to strike the opposite leg in progression.

On standing in front of such an animal the evidence of degeneration is very marked. The knees and feet are turned outwards, while the elbows are pressed in close to the side, and the chest is narrow, so that the whole limb is too close to the opposite one, particularly at the fetlocks. The knees are small, round, and narrow, and the leg below the knee is small and weak.

On viewing the animal from behind, the quarters are seen to narrow considerably from above downwards, the points of the hocks are close together, and the feet and stifles turned out. The hocks are small and weak, also the limbs below the hocks.

Limbs of this degenerate class always have small, weak bones and tendons, and a want of development of the natural bony prominences, which afford leverage for the muscles and tendons.

*Relative Influence of the Sexes.*—The general principles by which the breeder should be governed in the selection of the sires and dams respectively must now be dealt with, and in doing so we must touch on a subject about which there has always been a great deal of speculation, viz., the characteristics which are particularly liable to be transmitted to the offspring by each parent respectively.

As is the case in most questions on which there is a great deal of uncertainty among men of wide practical experience, we think that nothing very definite can be laid down for individual cases. The liability to variation is so great that, even in the offspring of the same parents, the type and character may be widely different, especially if the parents are not both well bred and of closely analogous type.

The factor of prepotency still further militates against the acceptance of any very definite rule, as some parents, either male or female, are so prepotent that they stamp their likeness very distinctly on the whole of their progeny, no matter how they may have been mated.

It is pretty generally accepted, however, among breeders that the male parent influences the outward formation particularly—*i.e.*, the external structure and organs of locomotion—and the female the internal organization. We think that is the general tendency, but, in view of the above-mentioned liability to variation, we do not think any great stress should be laid on it.

It seems reasonable to expect that each parent will be particularly liable to influence the characteristics which are specially developed in the sex to which he or she belongs.

Thus the sire would particularly influence the powers of muscular endurance, vigour, courage, and the locomotory apparatus, and the dam would be expected to influence quality, temperament, habit of body, and the organs of nutrition.

The point on which we would lay particular stress, as of the utmost importance in successful breeding, is the necessity of strongly-marked masculine character in the sires and feminine character in the females.

Parents which do not show the special characteristics of their sex strongly marked scarcely ever prove prepotent, and this fact is thoroughly recognised by most successful breeders.

Sires of all classes should possess marked courage and energy, and their frames, both of the body and limbs,

should be built on more substantial lines than in the female. The head should be big and massive, with a bold expression of the eye, and set on a strong, well-turned neck.

Any tendency to lightness of the neck should be avoided in a sire as it shows lack of constitution, and such sires are seldom successful stock-getters.

Quality in the sire is of importance as well as in the dam, but must be associated with more vigour. The female need not be so big as the sire, but must be very wide of hip and roomy of body to permit of the unimpeded development of the generative organs and foetus. She must possess quality, and the bony frame should not be so massive as in the male. The head should be small, with a mild, placid expression, and should show fine quality. The neck should be much lighter than in the male. The udder should be of the correct shape and well developed, and this is of importance, as the development of the progeny will be very much modified by the nourishment it receives in early life. Any tendency towards a lymphatic temperament should be carefully avoided both in sire and dam.

In the selection of the sire the criterion of the race-course or show-ring may generally be accepted as a safe guide, as a male which has proved a success in either sphere can generally be depended on to transmit his good points to the progeny, provided that his health has not been ruined by over-feeding.

In the case of the female this is not by any means so certain; in fact, exceptional females, either on the race-course or in the show-ring, commonly prove disappointing at the stud. The reason for this, we think, is not difficult to find. A mare which has the conformation which enables her to achieve great success on the race-course probably has not the width of hip and roominess of body which are essential to success at the stud, and also probably lacks feminine character.

In addition to this, if she has been kept in training for

a long time, her locomotory apparatus will have become specially developed, while the generative organs are certain to have atrophied more or less from inaction, and it is open to doubt if they can ever be developed to the same extent as they would have been if she had produced a foal at an earlier age. The thoroughbred mares, Signorina and La Flèche, will serve as instances of this liability to disappointment. Very high feeding also, over an extended period, undoubtedly militates against success at the stud. In the case of the successful show female, we think the unhealthy forcing to which they are subjected is chiefly to blame, especially if long continued.

This forcing of show animals until they arrive at an actually diseased state of fatness is a source of great damage to many of the best representatives of all breeds, and it is a great pity that something cannot be done to check it.

Almost every breeder of experience will be able to cite cases of exceptionally prepotent females, and in most cases we think it will be found that they are not above medium size and show a great deal of quality. We do not regard size in itself as a disadvantage in a female, but it is seldom associated with sufficient width, roominess, and quality, and any tendency to coarseness or legginess should be avoided, as such animals are scarcely ever a success at the stud.

Another question on which we must touch, and on which there appears to be a good deal of difference of opinion, is the relative importance of the influence of the sires and dams respectively in determining the permanent character of the stock as a whole.

There can be little doubt that the influence of any sire must be greater than that of any particular female owing to the larger number of his progeny, but we think that the true character of a well-established breed lies in the females as a whole; and although a sire can exert great influence, the established character of the stock will not be materially changed by one sire.

It is a very common error among a certain class of

breeder to attach great importance to the selection of the male parents and breed from any sort of female, often, in the case of mares, because they are too old and unsound to be of any further use for work. The result of such a system must be unsatisfactory, and the breeder will be fortunate if more than a small proportion of such mares should be capable of breeding. The successful breeder, on the other hand is equally careful in the selection of both sire and dam, and will seldom part with a prepotent female, as he recognises her great value. We understand that the Arab breeder does not attach very great importance to the influence of the female on the progeny, but we feel sure that every breeder of experience will be able to cite cases of females of extraordinary prepotency which could be depended on to produce good offspring, even when mated with inferior animals.

This prepotency is markedly hereditary, and in almost every breeding stock of any size one can find whole families descended from such a prepotent female which have inherited this quality. Such a family is of incalculable value to a breeder, and anyone who is collecting a nucleus should try to get typical representatives of similar families, even if they are not of exceptional merit themselves. The value of prepotent females is fully recognised among breeders of thoroughbred horses, and a 'dam of a winner' is of considerably more value than a mare which has not bred a winner. Owners of young improved sires are also very anxious to get a certain proportion of such mares to mate with their young stallions, as they recognise that they are much more likely to breed a winner than less successful mares.

We do not wish for a moment to minimize the importance of the sire, especially as he is particularly concerned in the transmission of the external characteristics which insure success in the show-ring and on the race-course, but the results can never be satisfactory unless he is mated with good females.

*Influence of Age.*—The question of the age at which

animals should commence and cease breeding is also of importance.

In the case of the male parent it is a pretty general custom to allow him to serve a small number of females at quite an early age, and gradually increase the number, and we think that this is the best system, provided that great care is taken to prevent him doing too much until he is fully developed. As regards breeding from old sires, it is very generally accepted that the progeny of very old animals is always liable to be small and weedy, and we think it a mistake to breed from animals which are losing their vigour. A great deal of harm may be done to the constitutions of the stock as a whole by the use of such a sire before it succeeds in attracting attention. Statistics tend to show that very young animals may not be very certain stock-getters, but in our experience the offspring is as a rule very good.

In the case of the female also we think it is a good system to get her to breed at quite an early age, provided that she can be maintained in extra good condition throughout the period of pregnancy and subsequently.

This system has the advantage of fully developing the genital organs at an early age, when the frame is capable of considerable modification, and thus stamping the maternal character on the animal.

Females which have bred at an early age are usually themselves very certain breeders afterwards, and, provided that the condition is well maintained throughout, we do not think that they are liable to be stunted in growth. In the case of mares we would recommend a year's rest from breeding after the first foal, during which time they could be trained and complete their development.

We have already referred to the practice of breeding from old, worn-out mares, but must again emphasize the fallacy of the system, as it is one of the greatest evils in breeding.

It is a very common practice among hunting men to send a favourite old hunter mare to the stud after she has carried

them well for several seasons, but the result, in our experience, has always been a more or less complete failure. In a considerable number of cases such a mare refuses to breed at all, and, if she does breed, the offspring is usually very small and weedy, unless she happens to have carried a foal at an earlier age.

Exactly the same result may be expected in breeding from old, worn-out mares which are past work in the streets and frequently unsound. The reason, we think, is the one we have already mentioned, viz., that the genital organs have become atrophied from continued disuse, and cannot be expected ever to develop to the same extent as they would have done in youth. The os uteri at the same time becomes contracted and hard, and accounts for the large proportion of failures to breed.

In addition to that, an animal which is more or less worn out should never be bred from, as the offspring, even if the genital organs are sufficiently roomy for its full development, cannot fail to lack robustness of constitution, and will also probably have the disadvantage of an inferior supply of milk. Breeders as a rule find that it does not pay to keep a dam for breeding purposes after she has passed her prime, unless she is a very exceptional animal, when it will be worth while to give the offspring artificial assistance from the day of birth.

*Mating.*—The successful mating of the parents is a science in itself, and we think to a certain extent intuitive, depending largely on the possession of the breeders' eye for a good female. The breeder's object in mating is to obtain the desired type, by correcting the faults of one parent by the strong points of the other.

In scientific breeding of thoroughbred horses, an attempt is made to calculate exactly the effect of the various strains of blood on the offspring; but, in view of the great liability to variation, even in the offspring of well-bred parents, we doubt if breeding can ever be reduced to so exact a science. The question of the capacity for 'nicking' also comes in here. Certain strains of blood appear to be particularly

suiting to each other, and are said to 'nick' well, but the knowledge of which particular strains will 'nick' well can only be gained by experiment.

The late Lord Falmouth, who was a most successful breeder of thoroughbred horses, believed he attributed much of his success to the fact that he seldom went on mating a mare with the same sire, but tried every possible combination of blood.

As we have already stated, the breeder should always look for size, vigour, and strongly-marked masculine character in the male, and quality, docility, and feminine character in the female. In the mating of animals of different breeds the same lines should be followed, *i.e.*, the sire should be from a breed particularly noted for development of the limbs and bony frame, while the dam should come from a breed noted for development of body. If the opposite practice is followed the result is seldom satisfactory; for instance, we have the authority of Professor McCall, of the Glasgow Veterinary College, for stating that the mating of Clydesdale sires and Shire mares is usually attended with great success, while the opposite is almost always a failure, the reason being that the Clydesdale is noted for fine development of the limbs, while the Shire is noted more particularly for the development of body.

We have seen exactly the same results in breeding hunters, and would always advocate getting the size, weight, and development of the limbs in the sire, and the quality in the dam, whether thoroughbreds or half-bred horses are used.

*Food.*—The question of feeding has been fully dealt with elsewhere, but we wish to emphasize the importance of a good, healthy condition of both parents and offspring throughout the whole year. Young, growing animals must never be allowed to get low in condition, or valuable time will be lost which can never be regained, and food which is only sufficient to maintain life is simply wasted, as no increase in value is taking place as a result of its consumption. The food of young animals should have a high



nutritive ratio, and should contain a high proportion of lime-salts and phosphates.

*Telegony.*—One other point on which we must touch is the question of 'telegony,' *i.e.*, the supposed influence on the subsequent progeny of a female of the first male with which she was mated. The idea that this influence did take place has been very generally held by breeders, but the series of most interesting experiments conducted by Professor Cossar Ewart with zebras, ponies, etc., afforded no confirmation of the theory, and, indeed, it would be a most difficult one to explain physiologically, so that we think it may be very safely ignored in practical breeding.

*Breeding Records.*—The breeder should keep careful records of all pedigrees and the results of his breeding and feeding experiments.

For this last purpose a 'weigh-bridge' is a most important addition to an up-to-date breeding establishment, and all animals should be weighed once a month to ascertain their progress.

Finally, to sum up, we would advise the breeder to pay careful attention to the following points in his operations, *viz.* :—

1. To carefully select the breeds and classes of animals most suited to the nature of the soil and climate.
2. To pay particular attention to the manuring, grazing, etc., of his land, so that it will produce herbage of the best class.
3. To avoid unnatural forcing and pampering, and maintain the whole of his stock in good, healthy condition throughout the year.
4. To lay down a definite type for each breed at the commencement, and rigidly reject any marked deviation from that type.
5. To pay careful attention to pedigree, and never to breed from a 'chance' animal.
6. Never to breed from an unsound or degenerate animal, or one which shows any tendency to weediness.
7. To look particularly for size, energy, and massive

development in the male, and fine quality and maternal character in the female.

8. To pay equal attention to the selection of the dam and sire, and never to part, lightly, with a prepotent female.

9. To commence breeding from both male and female at a comparatively early age, provided that they are well developed and can be maintained in good condition throughout.

10. Not to attempt to breed from old, effete animals, or females which have not been put to the stud till an advanced age.

11. To mate the parents so as to correct the faults of the one by the strong points of the other, but to avoid mating animals of widely different types.

## CHAPTER XV

### TRANSPORT BY SEA AND LAND

IF vessels could be built solely for carrying animals, there would be but little difficulty in arranging them so as to afford comfort, cleanliness, and a moderate amount of fresh air ; but ships are built for purposes of general utility, and the cattle boat of one voyage becomes the cargo boat of the next.

Ships are built to carry cargo and not animals, and when they are required for the latter purpose improvised methods have to be adopted, excepting in those boats which are built to carry cargo, and arranged with an eye to carrying animals if required. The only arrangements they receive for this purpose (and they are of the utmost utility), is giving a sufficient height between decks, and laying down in the construction of the vessel, permanent cants which can be utilized for stall or pen fittings if needed.

*Selection of a Vessel.*—As a rule it is a general-utility vessel which has to be selected, and the points of importance to inquire into before determining on the chartering, are the sea-going capabilities of the boat (which are always spoken of in the highest terms by the ship's officers, even if she be the veriest tub), her height between decks, the size of the hatchways, and the speed of the vessel.

A ship for animal transport cannot be too steady ; a certain tonnage is desirable, and ten tons per horse and man is the Government allowance, so that for 400 horses a ship of 4,000 tons is necessary. But 400 horses, although they take up a great deal of room, are very light as cargo

goes, and would only cause a few inches displacement of the ship, which would in consequence be very high out of the water unless properly ballasted for the conveyance of animals.

A vessel high out of the water has more motion than one which is nearer the surface, and is therefore lacking in steadiness; the latter is an essential quality for all ships used in animal transport. If they are known to roll they should certainly never be employed. A ship wide in the beam is steadier than a narrow one; on the width of beam depends the number of rows of horses carried. If four rows are carried on one deck the width should be at least forty feet.

The height between decks should not be less than eight feet for horses, though it is frequently less. Cattle and sheep could be carried in a vessel with less height than this, but there would be a corresponding reduction in cubic space. With horses height is essential to prevent injury to the poll.

The hatchways should be large as they then afford an easy means of getting animals up or down. A hatchway less than ten feet is no use for an animal transport; twelve feet should be the minimum measurement. The animals are walked down 'brows' or gangways fitted in the hatchway. If a hatchway is small, not only does it make a steep descent or ascent, but the chances are in the case of horses they will knock their heads against the coamings of the hatch.

Speed is important where a valuable cargo is concerned, and slow boats should be absolutely rejected; the highest type of cattle boat now crossing the Atlantic can do fifteen knots an hour. The principle should be to drive a vessel so long as fine weather lasts, but always to reduce the revolutions as soon as a sea gets up, or the animals will suffer from the motion. In very bad weather the ship should simply go slow and quietly ride it out, any other procedure will be attended by trouble and loss.

*Ventilation.*—The means of ventilation are all important,

but can never be satisfactory until vessels are specially built for animal transport. If this last condition were carried out the entire planning of hatchways and structural arrangements would be subservient to admitting air below ; whereas in the general construction of a ship, the air openings are reduced to the smallest possible number as interfering with deck space, and, further, where air can find its way water can.

Ventilation is also complicated by the number of decks employed for carrying animals, it is easier to ventilate two decks than three. No system of ship ventilation is satisfactory which depends entirely upon driving a certain amount of air into a space ; there must always be means for extracting air. The ordinary bell mouthed ventilator is intended to serve both these purposes ; turned towards the wind it is an inlet, turned away from the wind it is an outlet. In practice as well as theory they have this effect, but the number provided though sufficient for ventilating the ordinary cargo deck of a ship, is insufficient when that deck is converted into an animal transport. More ventilators mean increased deck space ; if they are aligned on each other they cannot all work as inlets when the wind is dead ahead as one covers the other, so that they require to be placed at various parts of the deck in order to be able to catch the wind, and this means interference with navigation. There are difficulties attached to introducing more ventilators, so that it is usual to supplement the usual trumpet mouthed structure by windsails which pass through hatchways to the various decks.

Windsails are excellent arrangements ; they should have a big square head, and an internal diameter of two feet ; below they should rest on the deck, and be carried forward some little distance from the hatchway to prevent the fresh air escaping by this channel before mixing with the air of the deck. As a matter of fact this is what generally occurs.

Windsails must not cover each other ; as they approach the bridge and the stern they require to be progressively

higher, to prevent one taking the wind from the other. They greatly reduce the speed of a vessel, and on this account are disliked by those responsible for navigation. There is also an objection to too many being rigged between the bows and the bridge, as in some vessels they interfere with the view.

All ventilators, whether of the bell-mouthed variety or windsails, require trimming every time the wind changes its direction or the ship her course, and when this needs doing half a dozen times day and night, it is likely to become neglected, especially at night.

Scuttles in the ship's side are available in fine weather, and should always be provided with wind scoops which are of the greatest use especially in the tropics, where the motion of the ship is probably the only air current produced.

All these contrivances depend on a wind being ahead; when it is astern the ventilation of the horse decks is most defective; when the ship is in port there is practically no ventilation excepting by diffusion, and the sick list increases at every stop.

Artificial ventilation appears to be the only real solution for supplying air on board a ship. A ship has been compared to a bottle with a narrow neck; there is plenty of air of the purest kind at sea, the difficulty is to introduce it; ships are proverbially close, stuffy, and objectionable.

Artificial ship ventilation may be effected in many ways. (1) By air conduits opening beneath the fires in the stoke-hole. (2) Exhaust pipes opening into the funnel. (3) Steam being ejected into exhaust pipes. (4) Jets of compressed air introduced into an air conduit, acting either as an extracting or propelling agent. (5) Rotary fans of the centrifugal variety. All the above act either by extracting or propelling air, and experience in ship ventilation shows that of the two propulsion is superior to extraction.

Edmonds' system of steam ejection is used as a means of drawing off foul air or distributing fresh. The apparatus consists of one or more ordinary lobster back or trumpet-

mouthed cowls, communicating with air shafts, which extend fore and aft along each side or midships. The shafts have perforations at every five or six feet.

If used for extracting foul air the ventilator is turned from the wind, a steam cock which passes into the interior of the ventilator is opened, and the steam thus ejected passes through a jetting arrangement and creates a vacuum, by which means foul air is drawn off while fresh air enters through the hatchways.

A 16-inch main ventilator with the steam on will extract 60,000 cubic feet of air per hour, which is a mere trifle where horses are concerned. As an air inlet it is turned towards the wind, the steam is cut off and air is driven along the shafts which are in communication with it.

Edmonds' system may be found on many transports; it is imperfect, but better than nothing.

We have previously dealt (p. 74) with the loss caused by friction in a tube or by bends. These are the difficulties and losses experienced by driving air through any tube system on a ship. As seen earlier in these pages a circular tube is preferable to any other shape, and should always be employed where possible. Of the various methods mentioned above, none would appear to be more likely to be effective than that of jets of compressed air; it is known as Green's system. A cubic foot of air under a pressure of 3 lbs. or 4 lbs. to the inch, is said to induce the extraction or propulsion of 25 cubic feet of ordinary air.

No ships for animal transport that we know of are ventilated artificially, with the exception of Edmonds' steam jet, but some such system is what has to be adopted on a man-of-war. The latter class of vessel, in the matter of ventilation, is in much the same plight as the main and lower deck of an animal transport.

It is obvious that all the decks of a horse or cattle ship are not equally foul; the lower we go in the interior of a ship the more difficult ventilation becomes, though strange to say it is the main and not the lower deck which furnishes the greatest amount of sickness. This is accounted for,

according to Martin,\* by the fact that the main deck is practically on a level with the water, while the lower deck is below the surface of the water; the one is heated by the sun in the tropics and gets unbearable, the other is kept moderately cool by immersion. This may be so, but it must also be borne in mind that the deeper one descends in a vessel the less motion is experienced.

We are compelled to recognise that the ordinary system of natural ventilation adopted for animal transports at sea is gravely defective; by dint of perpetual care, attention to windsails, bell-mouth ventilators, scuttles, windscoops, and clearing hatchways of every obstruction, we can succeed in keeping matters going, but the system is most defective.

*Fittings.*—The fittings for cattle ships are pens eleven

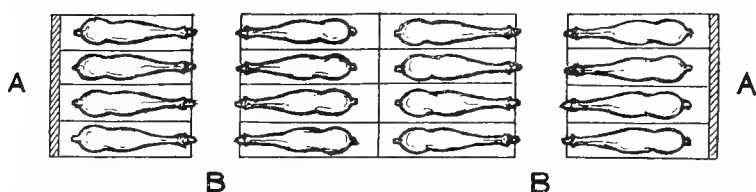

Fig. 210.—Portion of Deck Plan, showing four rows of horses. A is the ship's side; B, the gangways, on the proper width of which the successful management of the horses depends.

feet long by nine wide, the cattle in them are tied by the head, overcrowding is prohibited by law, and every animal must have room to feed and lie down. For a full account of what the law demands for cattle boats, see the section dealing with Legislation at the end of this chapter.

Horses may be carried in pens of three or four, or as in army transports in stalls. Stalls are placed along the sides of the vessel and down the centre; depending on the width of beam there may be four stalls across the vessel or three. With four stalls in the beam there is a row on either side and two rows in the centre; the horses' heads in all cases facing towards a passage running on the port and starboard side (Fig. 210).

\* 'Transport of Horses by Sea,' by Captain E. E. Martin, A.V.D.



The stalls are arranged across the ship, so that the animals stand at right angles to the direction in which the ship is moving, and this is the only position in which they should be carried, as they are then prepared to meet the rolling of the vessel. If pitching were more common than rolling, which fortunately it is not, the animals would have to stand in the long axis of the vessel.

The stalls are made of four posts, uprights, or stanchions, secured above and below; fitted into them is a breast and

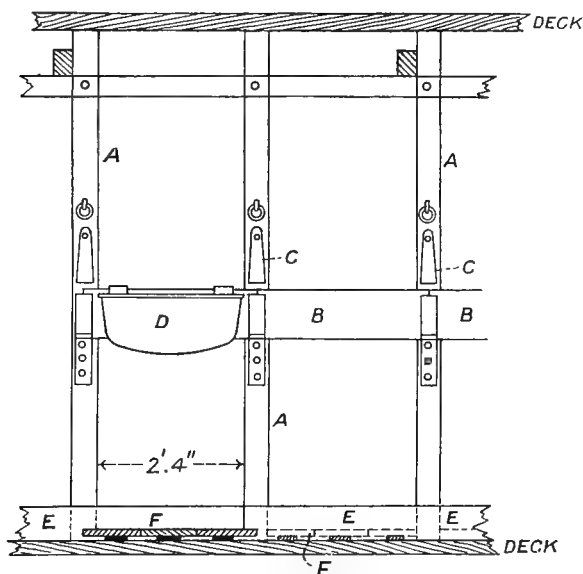

Fig. 211.—Front view of Horse Stall on Board Ship. A, front stanchions; B, breast bar; C, swinging stop; D, manger; E, front cant; F, platform.

haunch bar, and separating or side bars. The breast and separating bars are movable, the haunch bar is fixed (Figs. 211, 212, 213).

As each animal is placed in its stall, the separating bars are put up by sliding them into a groove, the breast bar is put in, and the animal's head tied up. The next horse is dealt with in the same way. Each horse is then in a sort of trevis.

All wood used in connection with this work should be strong, edges rounded off, no nails used, only screws, and no splinters left. In practice all this is otherwise, the wood-work is frequently flimsy, or badly put together, long wire nails are used which are easily displaced by a kick; the fittings are frequently rough, and splinters innumerable. Very often the carpenters are still working at the fittings as the horses appear on board, so that the 'finish,' rounding of edges, and desirable smoothing, may be imagined.

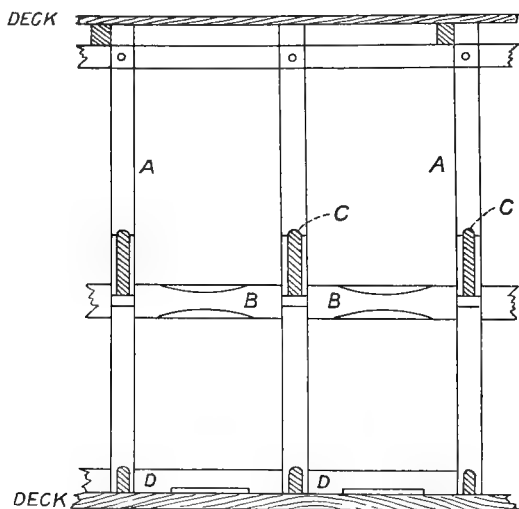

Fig. 212.—Rear Stanchions viewed from the front. A, rear stanchion; B, haunch bar; C, dividing bar fitting into a cleat; D, rear cant perforated to give exit to urine.

The standing of the stall is a movable floor (Fig. 211, F, and Fig. 213, G), made of three planks each one inch apart to allow passage for the urine; these rest on the deck. On the upper surface of the floor are certain battens at right angles to the stall to prevent the horse from slipping. Underneath the floor there are also battens running the length of the platform, by which it is kept off the deck, and the urine allowed to run away.

A heavy piece of timber 6 inches by 4 inches runs the whole length of the front of the stalls, to which the front

uprights are secured. It is known as the front 'cant' (Fig. 211, E, and Fig. 213, F), and is half a foot above the level of the deck. One object gained by the cant is to prevent the horse slipping out in front should the battens on the platform fail to keep him back, and in practice these battens are soon broken away. There is also a rear cant to which the rear uprights are secured (Fig. 212, D), while

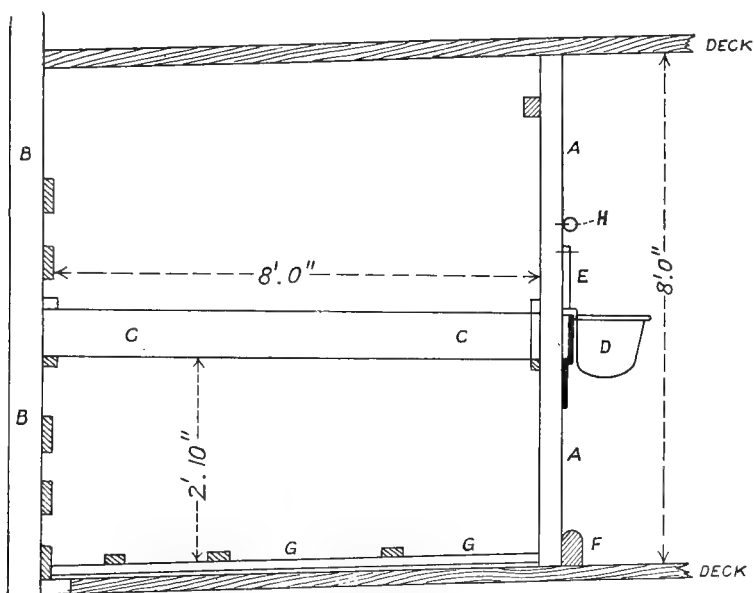

Fig. 213.—Side View of Stall, without rear stanchions or passage behind the horse. A, front stanchion; B, ship's side; C, side or dividing bar between the horses; D, manger hanging on breast bar; E, swinging stops; F, front cant; no rear cant required in stalls of this class; G, platform, with battens; H, ring to which the head is secured.

between each stall is a side cant to keep him from sliding on to his neighbour's ground. The rear cant is perforated 9 inches by 2½ inches, to allow the urine to escape into the scuppers.

These cants make a square wooden well of each stall, and dropped into this well is the movable wooden battened floor previously described.

The breast bars fit into an iron bracket on the front pair

of stanchions, and are kept in position by a swinging stop made of wood (Fig. 211, C). On to the front bar hangs the manger.

The parting or side bars, may be one, two, or three in number between each horse; they slide into a groove in the front and rear stanchions, and are a constant source of nuisance. Horses kick between them, sometimes get over them into the next stall, and injuries are frequent. One parting bar would be ample for the majority of horses, but it should be made of good stout timber 3 inches in thickness and 9 or 10 inches in depth, thoroughly secured into a strong mortise or cleat in the uprights (Fig. 213, C).

Too much attention cannot be given to this side plank, it may never be wanted the whole voyage, or it may be required within a short time of leaving port. Its function is to keep the animals from telescoping when the vessel pitches. It will be borne in mind the horse is only properly placed in the ship for rolling; when pitching occurs he is in a most disadvantageous position, and is thrown against the partition bar; if it breaks he passes into his neighbour's stall, if that gives way under double pressure the two are shot on to the next horse, and so on.

The lower edge of this side plank should be about 2 feet 10 inches from the platform on which the animal stands.

There are some horses which remain throughout a voyage sufficiently well to kick, and for them a single side bar will be insufficient, a second bar must be introduced immediately below the first; it should be 9 inches deep, so that the two form a protection of 18 inches against kicking. If there is no slot for the second bar to fall into, it can be secured to the bar above by lashing, and made to act the part of a swing kicking-piece on a bail.

The length of the stalls is an important matter to attend to, which will be evident when it is borne in mind what the apparent movement of the horse's body is during rolling. If one stands at the end of a gangway and watches the horses during rolling a curious sight is observable; as the ship, for

instance, rolls from left to right the heads of the horses standing on the right gradually come further and further out of the stall, while the animals facing them recede until they are entirely lost to view; as the reverse roll occurs the horses which disappeared now appear, while those the heads of which were projecting almost across the gangway, are now receding until they are lost to view. It reminds one of the man and woman in the old-fashioned weather clock, when as one comes out the other goes in. If there are fifty horses on each side of the gangway, the curious sight is presented of fifty heads appearing on one side, while fifty heads disappear on the other, all with absolute precision and regularity.

As a matter of fact it is the ship moving and not the animals, all they are trying to do is to maintain a horizontal position, and in so doing they appear to be undergoing rhythmical pendulum movements.

What this observation teaches is that a stall must be long enough to admit of these movements backwards and forwards, a short stall would result in injury to the neck or quarter or both. There must be sufficient length to prevent injury, and the length is from  $7\frac{1}{2}$  to 8 feet, depending on the size of the horse.

A stall of sufficient length is very properly insisted upon by Martin in his monograph previously mentioned. The official length of stall varies from 6 feet to 6 feet 6 inches, depending on the size of the horse, this is not long enough to allow the pendulum movements of the body. It is here convenient to note that the head ropes in bad weather must not be tied too short, or the horse will be unable to properly adjust his body to the rolling.

The internal width of the stall should be from 2 feet 2 inches to 2 feet 4 inches, depending on the size of the horse. No padding of any kind is required in stalls; the haunch piece previously spoken of is hollowed out for a horse to rest in, but this piece is quite unnecessary if the stalls are made longer, and carried right up the ship's side as they should be.

The official type of stall for military horses has a two-foot passage between the ship's side and the rear of the stalls, so that a man can go in and clean them out; but this is not required. No passage is needed behind the horses in order to clean the stalls; where a passage is wanted and where it is of vital importance is in the gangway, and here it cannot be too wide.

The height of the breast bar and haunch piece (if one is used) are important; a high breast bar with a small horse means injury to the neck, while as the manger is hung on the breast bar, it is obvious if the manger is too high the animal can only feed with difficulty. If the breast bar is made 8 inches in depth and 2 inches in thickness, its lower edge should be 2 feet 10 inches from the platform on which the horse stands, and the haunch bar should be  $2\frac{1}{2}$  feet from its lower edge to the platform. The side partitions or bars should be fitted at the same height as the breast bar.

Mule stalls are arranged to carry three or four animals; the width depends upon the number carried in each stall, but not less than 2 feet should be allowed each mule of medium height, 2 to 4 inches more will be required for larger mules. The depth of the stall will vary with the size of the mule, from 6 to 7 feet will generally be found sufficient. The fitting of breast and side bars is lower than for horses, 6 inches lower is sufficient for most animals, but it is a question of the height of the mule; the position of the breast bar is most important, for if too high their necks get damaged.

Valuable horses are frequently carried in specially made horse boxes, which are slung on board and then lashed to the deck. They are padded and well made, and placed on the upper deck with an awning overhead to keep off the sun and rain.

*Mangers.*—The mangers are hung as before mentioned on the breast bar; galvanized iron is used on military transports and has many advantages over wood. A horse on board ship has so much spare time that a wooden manger is a temptation to eat. Mules invariably eat away

all the woodwork they can get at; it is convenient to mention here that the only protection which can be given to woodwork, that is not covered by a zinc casing, is to smear it over with soft soap. Mules will not then touch it.

Mangers might be made longer and deeper, their width cannot be increased, owing to the obstruction they would cause in the gangway. It is useless attempting to use mangers for hay, so that hay nets should be provided or else the greatest waste occurs. As soon as the feed is finished mangers should be collected, washed with sea water, and placed ready for the next feed.

Great waste occurs with the ordinary board ship manger, many horses throw their food out of it, and this can only be prevented by two pieces of iron arranged like a manger guard (p. 316).

*Hay Nets.*—One secret of landing horses with flesh on them, and keeping them quiet at sea, is to supply them with hay, and the only way to give them hay is in a net. Any other system is utterly wasteful. The mesh of the net must not be large, it is surprising how horses manage to extract the hay through a small mesh; it takes time which is a great advantage, as they have twenty-four hours at their disposal for feeding. A hay net capable of containing a pound or two of hay, should be hung from each stanchion, and filled up from time to time. Any hay lying in the gangway is wasted, and shows the system has not been carried out. It is quite impossible to overrate the importance of hay nets on board a ship and their economic advantage. A ship's hay net might be specially made sufficiently long to tie to each stanchion and pass across the front of the horse; the present military net hangs up like a ball on the end of a string.

*Slings.*—The old idea of slinging horses in their stalls on board a ship has finally exploded, it took many years to kill the preconceived prejudice.\* All veterinary officers of

\* The credit of abolishing the use of slings is due to Colonel Duck, C.B., late Director-General A.V.D., whose views were published in the first edition of this work.

experience condemned them, for it is obvious if a horse is in slings he is simply swinging to and fro with the rolling of the ship, the very thing we wish to avoid. What we want horses to learn on board is to resist the rolling by maintaining a horizontal position, and this is impossible with slings beneath the body. Two per cent. of slings for veterinary purposes are ample.

*Hospitals.*—A certain amount of accommodation for the sick is needed, and should be surplus to all their requirements. The hospital should be situated on the upper deck and consist of stalls and boxes, the stalls having the same measurements as those used for healthy animals, while the boxes may be specially made or improvised by taking away the stall partitions. A comfortable floor can be made for a colic case by means of coir matting, of which plenty should be on board.

It is well to have two hospitals, one fore and aft, as it will be found more convenient.

Apart from regular hospital accommodation, care should be taken to provide more stalls than there are horses. This admits of animals being readily moved for any purpose, or for treatment.

If a modern vessel is employed as a transport and built in bulkheads with watertight doors, such a construction is most convenient for horse ships; when the doors are open there is a clear air way along the length of the deck fore and aft, which facilitates ventilation and economizes time, as one can walk the whole length instead of having to visit separate compartments communicating by companions.

*Gangways.*—This leads to a subject of supreme importance on board ship, viz., gangways, or the passage on either side of the vessel towards which the horses' heads are turned, and from which the whole of the work of feeding and looking after them is carried out.

A gangway should not be less than 3 feet broad, it is usually made 2 feet; at the ends of the vessel where she narrows the gangways are reduced to about eighteen



inches, in order to still get in the four rows of horses across the ship. What ought to be done at the narrow ends of the vessel is to omit one row of horses, so as not to interfere with the width of the gangway.

The gangway is all important. If too narrow, viz., the 2 feet laid down for transports, the opposite horses can touch noses; this is undesirable when disease exists, and horse ships and disease are inseparable. From the gangway the horses' stalls are cleaned out; from the gangway the animals are fed and watered; in the gangway they are placed when being moved from one point to another; finally, and most important of all, in the gangway they are exercised.

Where gangways are made narrow in order to get more horses on board, it is an unsuitable boat for military purposes, for the great object should be to have every horse out of his stall daily and walked about; the only thing which should prevent this is the weather; at present the only thing which prevents it is the difficulty, sometimes the impossibility, of doing it.

*Exercise.*—To exercise horses on a ship a 3 feet gangway is required, so arranged as to form an irregular circle around the compartment. If it were not for the watertight doors they could be walked all round the ship, but if exercised in their own compartment gangway it will be found equally satisfactory. It is evident there must be a clear passage all round; there is no turning back once the horse is in the gangway, he cannot turn in a space of 3 feet, so that to get back to his stall he must go all round until he comes to it again. There must be no obstructions; hatchways leading to other decks may have to be crossed by a bridge, but it must be done; the exercising party should circle around the deck, ten or twenty horses at a time, for as long as can be spared; they are then put back in their stalls, and the next twenty taken out. Coir mats are put down on the deck for this exercise.

While the exercise is going on the horses awaiting their turn spend their time by biting their companions as they

pass, which they can readily do. This frequently necessitates men placed at an interval of every three or four horses to control them. They can sit on the side bar between the stall, there is no room in the gangway for them.

Exercise on board is the essence of ship management for all horses, but especially military, because it facilitates their being got in condition on arrival, it stops laminitis, it eases the joints, and regulates the bowels. It takes time, but as soldiers have nothing else to do, this is unimportant.

We are particular in impressing the necessity for a 3-foot gangway. In Government transports a 2-foot passage between the horses and the ship's side is provided for, but is perfectly unnecessary. Half the space thus taken up may be thrown into the ordinary gangway of 2 feet, and the remaining half used to lengthening the stalls.

There should be no difficulty in arranging a mechanical device for exercising horses on board a ship, so that some other pace than a walk could be got out of them. The principle to employ for this purpose is a revolving endless platform arranged as an inclined plane, up which the horse has to climb; at every step the platform passes from beneath his feet and acts as a treadmill. There is nothing novel in this suggestion; something similar was used before the days of steam for the purpose of grinding corn or other mechanical effects, and was worked by horses. The inclined plane, which was as steep as 1 in 4, was arranged either in a series of low steps, or the steps were replaced by a level tread; the latter was generally considered best for the animal's limbs. This equine treadmill was on wheels, and carried about to different parts of the farm where horse-power was needed.

Professors Zuntz and Lehmann of Berlin, used a somewhat similar contrivance when inquiring into the chemistry of respiration in the horse; they were also able to regulate the speed of their platform, so as to produce something resembling the faster paces.

*Drainage.*—The drainage of the horse decks is simple and defective. The platform on which the horse stands does

not, as previously described, rest directly on the deck, but has some longitudinal battens which raise it sufficiently to allow the urine, which passes between spaces in the platform, to run away towards the sides of the vessel, and thence to a narrow pipe which conveys the urine to the bilge. As the narrow pipe is generally plugged with manure, the lowest point of the deck has frequently a shallow pond of urine which runs from side to side or front to rear depending on the motion of the vessel. In other words the waste pipes to the bilge are not large enough.

It would be far better to allow the drainage from all decks above water-level to pass directly over the side through a flap valve, and use the bilge entirely for the drainage of the lower decks. Instead of passing the urine into the bilge, it might be emptied into special urine tanks under the lower deck, and be pumped out daily.

The method of disposal of the solid excreta on an ordinary ship is to leave it under the animals until the voyage is over. Anything more filthy cannot be imagined; as it accumulates behind the horse he is pushed up higher and higher, until his hind quarters are several inches above his forehead. The condition of the feet steeped in this fermentable poultice can be imagined, while the stench when the mass is disturbed is intolerable.

We do not wish to see a passage behind the horses for cleaning out the stalls, it is not necessary, and if put in takes off from the width of the gangway which is an absolute essential. Stalls can be cleaned out by removing a horse, clearing out the stall, putting the next horse into it, and so on throughout the length of the deck. If a spare stall is left between every group of ten horses, the whole thing is absolute simplicity. The dung is collected in baskets and thrown overboard.

There is not the slightest reason why the hose should not be turned on to the stalls daily after cleaning out; it would flush the stalls, and do the horse's legs and feet good.

*Water.*—The water for horses on board ship is generally carried in iron tanks, which if shaken up with weather

causes it to come out rusty but does no harm. Water must be supplied to every deck; watering horses is slow work when each bucket has to be drawn by hand. Under ordinary circumstances horses require water three times a day, and in the tropics they should be tried at night for a fourth time.

*Grooming* at sea is a very tame affair unless the horse is taken out of its stall, or two stalls made into one. As a matter of fact very little grooming is done, an occasional brush along the back from a man standing or sitting on the parting bar is about all that can be attempted. In the fitting up of transports, a space could be left in each compartment where half a dozen horses could be groomed at one time; these could be groomed by machinery so as to facilitate matters, and keep as few men as possible below. It should be borne in mind that the more men below the greater the vitiation of the air.

There is no difficulty in the animal's legs receiving attention; if the body cannot be brushed the legs can be handrubbed, which for tired joints standing in a constrained position is most beneficial.

*Clipping* should be practised in passing from winter in Northern latitudes to summer in Southern. Those horses that sweat the most should be the first done, and these animals will be found in the stalls close to the engine-room. Mechanical clippers should be used driven by an electric motor.

*Feeding.*—The feeding on board must be regulated by the length of the voyage; the system is to start moderately low with corn, and gradually increase it towards the end of the voyage; also to regulate the bowels with bran and if possible carrots throughout the journey. If the voyage last three weeks the diets may be as follows:

For the first week—

				Lbs.
Corn ...	...	...	...	3
Bran ...	...	...	...	3
Hay ...	...	...	...	10 to 12 lbs. daily
Carrots	...	...	...	5

The second week the diet may be—

						Lbs.
Corn	...	...	...	...	...	5
Bran	...	...	...	...	...	5
Hay and carrots as before.						

During the third week—

						Lbs.
Corn	...	...	...	...	...	7
Bran	...	...	...	...	...	5
Hay and carrots as before.						

There is no secret in dieting horses on board ship; keep them moderately low by not overdoing the corn; increase the diet, gradually not suddenly; give bran and carrots to regulate the bowels, and sufficient hay to afford the needful bulk. Make the horses eat their hay slowly by putting it in nets, and if it takes them an hour to eat a pound so much the better, it will be the means of keeping them quiet for half a day, and at the same time insures thorough mastication.

*Diseases.*—No nitre is required with the food and no vinegar on the body; these are ancient methods of dealing with horses at sea founded on ignorance and misconception. The only medicine they may require is Magnesium Sulphate, but the best medicine is bran; and the best treatment for bowel derangement, from want of exercise or other causes, is aloes by the mouth and plenty of sea water by the rectum.

There are diseases, however, which cannot be regarded in a light manner, one is pneumonia and the other 'ship staggers.'

Pneumonia may appear twelve hours after the horses are on board, it runs a rapid course, soon becomes putrid, and death occurs in three or four days. The pleura as well as the lung tissue is affected. Some animals will die in an hour or two, the previous symptoms not having attracted attention.

The disease sets in quite suddenly, frequently several horses are simultaneously attacked, or in the course of a few hours. A few recover, some partly recover to die later

ashore, probably after a tedious and indefinite illness; many die without ever rallying.

The disease is infectious, and due to an organism which finds a congenial soil in the atmosphere of the horse deck. Nor is the disease limited to decks below; we have seen it in horses standing on the upper deck, though it is possible the infection was conveyed to them from below.

If these cases are to have any chance of recovery they must be got up into the open air; but the disease is a most heartbreaking one to deal with, and the mortality so high that it leaves very little hope of success.

Ship Stagers is also an unsatisfactory disease; such opportunities as we have had of examining the brain throw no light on the affection. We have known it occur in quite moderate weather, though it is generally associated with considerable motion of the ship; it may be due to some reflex action through the vagus owing to the inability of the horse to vomit. The symptoms are very alarming, and the horse dangerous to a degree.

To get him out of his stall to an open hatch or under a windsail is of the first importance; but there are some cases unable to rise, and so violent as to preclude this being done. If the horse can be got out of his stall and put under the cold air douche, the symptoms will abate, often in an astonishing manner (Duck).

Laminitis is a frequent disease on board, many cases do not show it until they are being disembarked. It is caused by standing in one position without a rest, and is aggravated by the strain on the lamina during bad weather.

The *Mortality* among horses at sea is usually high. Anything from 1 to 3 per cent. may be regularly looked for from disease. In some cases it is much higher, even 10 per cent. from disease. If fittings give way during bad weather the mortality from broken legs and other injuries may be anything.

The losses not only differ on various ships, but also from different ports. Of 76,830 horses sent from England

during the War in South Africa 6·04 per cent. died; of 60,352 sent from Hungary 1·96 per cent. died; of 109,839 shipped from the United States of America 2·63 per cent. died; of 14,611 shipped from Canada 3·22 per cent. died; while of 26,616 shipped from the Argentine only ·54 per cent. died. These losses include the casualties before shipment, but are nevertheless comparable.

The latter figures might lead one to believe that latitude had something to say to it, and that horses passing from south of the equator to South Africa were in a better position than those passing from winter to summer in the course of a week or so; but this view is not entirely tenable.

Speaking roughly it may be said that the mortality among horses shipped from England to South Africa was double that of any other country.

Mules are far better sailors; during the South African War ships carrying a thousand mules would arrive with the loss of three or four only. Of 81,524 mules shipped from the United States to South Africa 2 per cent. died.

The mortality among other animals at sea is much less than horses. Of 310,498 cattle sent from America to the United Kingdom in 1900 only ·24 per cent. were lost, and of 96,544 sheep ·71 per cent. were lost. It is interesting to note that during the same year 29,064 horses crossed the Atlantic from America to Great Britain, with a loss of 2·55 per cent.; while in the succeeding year 23,351 crossed with a loss of 1·73 per cent., which is extremely low. During the years 1901 to 1903 inclusive 1,404,591 cattle were imported from Canada and United States into Great Britain, with a loss of under one quarter (·22) per cent., while during the same period 911,099 sheep were imported from the same country with a loss of 1·3 per cent.

In bringing forward these figures, it is not intended to convey the idea that the loss of horses can be brought down as low as that for cattle. When a horse will learn to lie down and take matters quietly on board a ship, and can be given immunity to ship pneumonia, we may then

expect the losses to fall to that of cattle. At present two to three per cent. of loss appears inevitable among horses at sea.

*Treatment before Embarking.*—Before horses are placed on board a ship, they should if in hard work be reduced both in work and diet for a few days prior to embarkation, and their bowels rendered laxative.

On the day of embarkation they should be watered before going on board as it saves trouble, and after being placed in their stalls they may be fed with hay, in order to settle them to their new surroundings.

They should embark as far as possible newly shod with both fore and hind shoes on. Shoes should never be removed for a voyage.

Good health prior to embarkation should be insisted upon; the weak or feverish will probably succumb. Freedom from infectious and contagious disease is a veterinary duty of the utmost importance; it is far better to leave a doubtful case behind than to run any risk by taking him. No more favourable conditions are conceivable for the spread of disease than life on board a ship, for the animals are packed closely together, frequently with their muzzles touching, and there is the utter impossibility of keeping the feeding troughs separate, and in addition the animals are breathing a vitiated air which lowers their powers of resistance. Glanders, strangles, pneumonia, and mange, are diseases among horses which soon get a foothold, and find most congenial conditions existing for their spread at sea. The most rigorous inspection before embarkation is necessary to avoid their introduction, while all animals should have been previously malleined; if such a disease as a case of mange got on board, it would be sound economy to at once destroy it in order to stay its spread, as it is almost impossible to treat mange effectively at sea, while it spreads in the most extraordinary manner on board.

A febrile condition is very common at sea; it may be due to heat in the tropics, but is more commonly caused by air



poisoning and nausea. Such cases are frequently the prelude to matters more serious.

The inspection of animals on landing is also of the utmost importance, and should be most thoroughly performed, especially those intended for a Remount Dépôt. The inspection of foreign cattle on landing in Great Britain is a duty of national importance, and is dealt with in detail on p. 639.

*The Care of Horses after Landing* is a matter of supreme moment. It will take the animals as long to regain condition on shore as the journey occupied. If horses have been three weeks at sea they should be at least three weeks being put in condition, and many will require longer. To work them at once is the height of folly, and can only result in laminitis and exhaustion. As to the best method of putting them in condition, the section dealing with this subject may be consulted.

*The Veterinary Duties* on board are of the most exacting and harassing kind; they last the round of the clock. An inspection of every animal on the boat must be made at least three times in the working twelve hours, viz., 6 a.m. to 6 p.m., and a fourth visit should be paid at night. These visits are the means of picking out all cases of sickness as early as possible, and detecting irregularities in stable management of which the most common is the waste of hay in the gangway, and insufficient watering.

It takes a long time to go round a ship and inspect three or four hundred horses, and one round seems to be hardly completed before the next has to start; but there is a feeling of security given by these inspections which no inspection by laymen can take the place of. This is the time when the early removal of a case to the upper deck, or other place of fresh air, may be the means of saving life; a few hours lost in the treatment of a case at sea can never be made good.

A surgery should be fitted up at either end of the vessel, but very little medicine is required; what is needed is incessant care and supervision.

## LEGISLATION.

There are three distinct Orders of the Board of Agriculture dealing with the protection of animals on board a ship. One is entitled the *Animals (Transit and General) Order, 1895*, and deals solely with animals carried on vessels between any two ports in Great Britain. The other is the *Foreign Animals Order of 1903*, and applies to vessels on which foreign animals intended to be landed at a Foreign Animals Wharf are carried to a port in Great Britain; the third is the *Exportation of Horses Order of 1898*, which applies to all vessels, other than military transports, in or on which horses are carried from any port in Great Britain to any port outside the British islands.

Besides these three main Orders, there are two others, viz., the *Channel Islands Animals Order of 1896*, and the *Isle of Man Animals Order of 1896*, regulating the traffic between those islands and Great Britain. They are based, so far as the ship accommodation and fittings are concerned, on *The Animals (Transit and General) Order, 1895*.

These Orders are of considerable importance from a humanitarian point of view, as there are more than half a million of both cattle and sheep imported annually into Great Britain.

*The Animals (Transit and General) Order, 1895*, deals only with animals carried on vessels between any two ports in Great Britain. It directs that no animals\* are to be carried on a hatch above a compartment where other animals are carried, nor shall they be carried on any part of the vessel which would interfere with its navigation, ventilation, or efficient working of the boats.

The fittings on these vessels are to be pens ten feet by nine feet, made of substantial material, and securely fastened to the deck. They must be of sufficient strength to withstand weather and the weight of the animals thrown against them. The floor of each pen shall be fitted with suitable battens securely fastened to the deck to afford a foothold, and strewn with sand or other suitable material. All cattle must be securely tied by the head. Ship's fittings likely to cause injury to animals must be properly fenced off, and animals must be protected against undue exposure to weather.

No passage way shall be less than one and a half feet in width.† Proper gangways must be provided for sheep carried on deck.

The ventilation must be sufficient and suitable, both for the admis-

---

\* The word 'animals' means ruminants and swine only.

† This does not apply to vessels employed in the trade at the date of the Order.

sion of fresh and discharge of foul air.\* The vessels must be properly lighted both in passages and pens, and provision made for adequate light in tending the animals.

The vessel must not be overcrowded so as to cause injury or suffering to the animals.†

Food and water must be placed on board for any journey that exceeds eighteen hours. A sufficient number of qualified attendants must be provided to tend and look after the animals.

Gangways and passage ways are to be so constructed that injury is not caused to the animals.

Between the 1st Nov. and 30th April no sheep shall be carried on deck that have been shorn within sixty days.

The master of the vessel has the power to destroy any animal with a broken limb or seriously injured during the voyage, unless he is satisfied it can be kept alive and led away without cruelty.

A return of casualties on board is to be kept by the owners of the vessel, and a copy sent to the Board every month.

If an Inspector of the Board certifies that any of the provisions of this Order have not been observed, the animals shall be detained at the place of landing until the Board otherwise directs.

Water is provided free at either the shipping or unshipping place. Food may be supplied at the unshipping place on payment.

At every place where animals are landed provision must be made for their speedy and convenient landing.

Vessels carrying animals at sea or inland navigation, must be cleansed and disinfected before taking on board other animals or cargo. The parts soiled by excreta shall be scraped, swept, scoured with water, and a coating of limewash applied. All fittings, pens, utensils, etc., shall be dealt with in a similar manner. All scrapings and sweepings are to be mixed with quicklime before they are landed. Ferry boats used in the transport of animals, are to be cleansed and disinfected once in every period of twelve hours within which they are so used.

All partly consumed and broken fodder, and all litter which has been used by animals either at sea or inland navigation, shall be landed, then well mixed with quicklime, and effectually removed from contact with animals.

Gangways, passages, cages, or other apparatus used in the loading or unloading of animals, either in transit by sea or inland navigation, shall as soon as practicable be scraped and swept, all dung and litter effectually removed, then thoroughly scrubbed. The scrapings will be dealt with as above.

---

\* The Order is silent as to what constitutes sufficient and suitable ventilation.

† The Order does not define what constitutes overcrowding.

When a landed animal is found to be affected with disease,\* the place and every other place the animal has occupied since landing, shall not be used for any fresh animals until it has been cleansed and disinfected.

If anything which is ordered is neglected to be done, or anything done in contravention of this Order, it constitutes an offence against all concerned.

*Exportation of Horses Order of 1898.*

This Order prohibits the conveyance in a vessel from any port in Great Britain, of any horse which owing to age, infirmity, illness, injury, fatigue, or other reason cannot be conveyed without cruelty during the intended passage and on landing.

The Order applies to all vessels, excepting Government transports, on which horses are carried from any port in Great Britain, to any place outside the British Islands.

The Order must be enforced by the Local Authority. The general powers of Inspectors, and the duties and authorities of the Police, laid down in Sections 43 and 44 of the Diseases of Animals Act, 1894, apply to this Exportation of Horses Order, as also the provision for offences and legal proceedings laid down in the Act of 1894.

The general powers of an Inspector alluded to above, enable him among other things to have a ship detained, when he is satisfied an Order of the Board has not been, or is not being complied with on board a vessel in a port; Section 692 of the Merchant Shipping Act of 1894 prescribes the penalties to be inflicted for a disregard of detention.

Each horse carried under this Order must be provided with a separate box or stall of sufficient size, constructed of substantial character, and of sufficient strength to resist the weather and weight of the horse when thrown against it. The floor must be battened and suitable substance used to prevent slipping. Each box or stall must be provided with slings. Ship's fittings liable to inflict injury must be fenced off, and protection against undue exposure to weather must be provided.

The matter of ventilation, light, passage ways, gangways, and attendance are the same as in the previously quoted Order.

Food and water must be supplied, and a suitable place provided for the accommodation of food, so that it may not be exposed to the weather.

All horses must be properly secured by the head.

---

\* The term 'disease' here refers only to those which are scheduled under the Diseases of Animals Act; see p. 480.

*Foreign Animals Order of 1903.*

Applies to vessels on which foreign animals\* intended to be landed at a Foreign Animals Wharf are carried to a port in Great Britain.

Animals are not to be carried on more than three decks, nor on any hatch above a compartment where other animals are carried, nor on any hatch the coamings of which exceed eighteen inches in height, nor in any part of a vessel where they would interfere with navigation, ventilation, or efficient working of the boats.

The size of the pens, flooring, protection against weather, and injury, are the same as in the Order first quoted. Pens are not to be overcrowded, and sufficient space must be allotted to enable the animals to feed and lie down.†

The question of light, food and water, approaches and gangways, are the same as in the Order first quoted.

All cattle whether polled or not are to be tied by the head or neck so as to stand athwartships.

Qualified attendants for the proper care of the animals must be carried, and in charge of a responsible foreman. The total number of persons thus provided should be one for every twenty-five head of cattle.

Injured animals may be destroyed by the master, unless he is satisfied they can be kept alive and led away without cruelty.

Any maimed or injured animal landed, shall be destroyed by the owner or person in charge if directed by an Inspector of the Board so to do.

Up to this point the Order is clear; it refers to 'animals,' viz., Ruminants and Swine coming from Foreign Countries, and landed at certain Foreign Animals Wharfs.‡ In dealing with pens, fittings, space, overcrowding, ventilation, passage ways, light, attendance, food and water only the term 'animal' is used, but when the Order deals with 'disinfection' horses, asses, and mules are for the first time mentioned, and it is directed that for the purpose of disinfection the above equines become 'animals' within the meaning of the Act.

---

\* Though the term 'animals' only means all ruminating animals and swine, yet this Order later on speaks of horses, asses and mules. It is evident these are not landed at a Foreign Animals Wharf within the meaning of the Act, so that some confusion exists so far as equines are concerned.

† As the pens are eleven feet long by nine feet deep, it is a pity the Order does not state how many animals each should contain.

‡ These wharfs are at the following ports: Bristol, Cardiff, Glasgow, Hull, Liverpool, London, Manchester, Newcastle-upon-Tyne, and Southampton.

The Order regarding disinfection says 'a vessel from which foreign animals have been landed in Great Britain' (no mention of the words Foreign Animals Wharfs) shall after the landing, and before any other animals or cargo are placed on board, be cleansed and disinfected in a manner to be presently described.

There is no mention of how foreign horses are to be carried, the nature of the fittings, or ventilation; further, until the disinfection chapter is arrived at, the Order applies purely to cattle and swine.

The disinfection above spoken of consists in scraping all parts of the compartment in which any animal or its excreta have come in contact; these parts to be scrubbed, then thoroughly *sprinkled* with a solution of carbolic acid and limewash; fittings, pens, hurdles, or utensils to be scraped, scoured and *sprinkled* with carbolic acid and limewash, and the scrapings and sweepings to be well mixed with quicklime and effectually removed.

If any horse, ass or mule is carried in a horse box, then it is sufficient if the horse box be disinfected by scraping, sweeping, removing all excreta, and washing the box with soap and water. No lime or carbolic acid are directed to be used after the preliminary washing of the box.

Gangways used for the loading and unloading of foreign animals are to be cleansed and disinfected as soon as possible, by scraping, sweeping, scouring with water, and then *sprinkled* with a solution of carbolic acid and limewash.

Under the chapter 'Miscellaneous' of this Order, are instructions dealing with the carcasses of animals dying on the voyage, and it is stated that 'if a vessel arriving at a port has on board the carcass of a foreign animal, horse, ass, or mule, which was taken on board for the purpose of importation, but died on the voyage,' the master shall report the fact to the officer of *Customs* on arrival.\* The carcass cannot be landed from the vessel without the permission in writing of that Officer.

It is very difficult to see what the Customs have to do with the matter, but the Order goes on to say that if in the opinion of the Principal Officer of Customs disease may be introduced by any foreign animal, equine, carcass, litter, dung, etc., he may seize and detain the same!

---

\* Our object in drawing attention to this paragraph is that horses, asses, and mules are for the second time mentioned in this Order, though the Order is essentially one referring to foreign cattle which are permitted to land at a Foreign Animals Wharf.

Beyond these two paragraphs there is nothing dealing with the importation of foreign horses, although the annual importations into Great Britain are considerable, viz., an annual average of 45,750, during the five years 1896-1900.

## TRANSPORT BY RAIL.

*Horses.*

The transport of horses by rail is a very simple and comfortable procedure when the ordinary padded horse box is used; but military horses have to be carried in trucks which are frequently open, and a few words on the subject may prove of use.

The general notion with regard to trucking horses is that they require to be hauled in and their heads then tied up. Both are wrong; they want to be led in without any hauling, a quiet and confidential horse leading, which

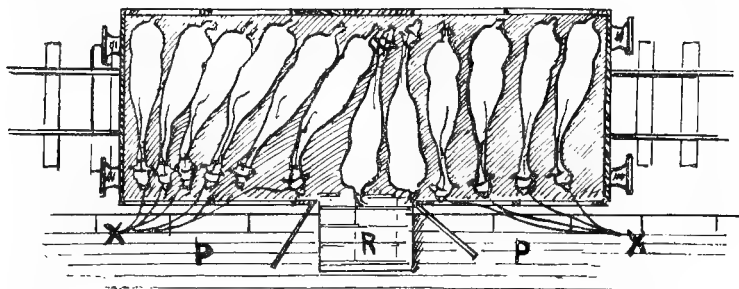

Fig. 214.—Diagram of truck loaded with horses. PP is the platform; R, the lamp leading into the truck. At XX stands a man to receive the head-ropes as the horses are loaded.

is then turned round, and his head-robe thrown over the truck for a man on the platform to hold. Once the first horse starts going in the others must follow without a check. Horses are very much like sheep in following each other. Every alternate horse should turn to the right or left with the heads facing the loading platform, the heads being held by head-ropes passed to a man on the platform. The last two horses are pressed in with their heads the reverse way, owing to the fact they cannot be turned round. Fig. 214, drawn by Major Eassie, A.V.D., exhibits the loading up of horses in a military truck.

It would be best for all the horses' heads to be turned

away from passing trains, and a further advantage gained by this is that they are then generally in the best position for watering and feeding.

After all the horses are in the door is closed, and the head-ropes thrown back into the truck and left trailing on the floor.

Some military journeys abroad last several days, and this necessitates a carefully thought out programme for the horses, prepared in conjunction with the railway authorities. It may be taken as a rule that for the effective watering and feeding of these horses, they ought if possible to be detrained twice in each 24 hours. The length of time it takes them to water, and to consume a given amount of corn and hay, plus the time occupied in entraining them again, is the period for which the train should stop. Say, if possible,  $1\frac{1}{2}$  hours. Watering and feeding in railway trucks is a most unsatisfactory proceeding and a wasteful one. Under certain military exigencies it may be impossible to detrain at regular intervals; in this case both watering and feeding must be done in the truck as best possible, but it can only be done by turning out the men at any hour of the day or night when water is available. Hay under these circumstances would be wasted, but corn can be given in nosebags, and two men should travel on each truck at feeding time to attend to this matter.

The truck containing the forage for a troop train should be the furthest from the engine; we have known of serious accidents from the neglect of this elementary precaution.

When a horse gets cast in a truck there is only one way of getting him up, and that is by taking a couple of horses out. There should always be a man riding on each truck to render what assistance is possible in the event of difficulties occurring, or to call for help at the next stopping place.

If it is fine weather there is no comparison between an open and a closed truck for comfort; the closed trucks are stifling on a hot day, especially when made of iron as many are on our colonial railways.



*Cattle.*

In the conveyance of Show cattle by rail, it is generally considered that with the ordinary cattle trains running in connection with Exhibitions, the risk of contracting disease is very great as these trains pick up all comers ; we do not know that there is much evidence bearing on this point.

If horned cattle are carried in the ordinary horse box instead of cattle trucks, they are liable to knock a horn off against the hinged partition which is used to separate the horses' heads, unless this is unshipped or so secured as to be out of harm's way. Failing this it is better to turn the animals' heads the other way, allowing them just sufficient rope to lie down. All small cattle, calves, heifers, or young bulls, should invariably be turned round and tied the reverse way, as when frightened by the train they are liable to double themselves up, and get their bodies wedged between the front of the partition and the wall of the horse box (Houseman\*).

In the conveyance of ordinary cattle by rail, there has been vast improvement within recent years owing to legislative enactments, the result of public opinion. Injuries during shunting are now less frequent, and animals arrive at markets in a saleable condition.

## LEGISLATION.

*The Animals (Transit and General) Order of 1895* deals not only with transit by Sea, but also by Rail and Road.

It directs that every railway vehicle used for carrying any animal shall be provided with two spring buffers at each end ; the floor of the vehicle shall be littered or sanded, or provided with battens or other proper foothold.

No overcrowding in any railway vehicle is permitted.

Between the 1st Nov. and the 30th April sheep which have been shorn within sixty days, are not to be carried in any uncovered railway vehicle.

A horse box used for horses, asses, or mules, shall on every occasion after use be cleansed before any other animal is placed therein. All

---

\* 'Cattle Breeds and Management': Live Stock Handbooks, No. 4.

excreta and litter shall be removed, the floor and other parts soiled by dung shall be scraped and swept, and scrapings, sweepings, and litter shall be mixed with quicklime and effectually removed. The sides of the horse box, or other parts capable of being soiled by a discharge from the mouth or nose shall be washed.

Any railway vehicle (not being a railway truck) used for animals\* shall on every occasion after an animal is taken out, and before any other animal or horse, ass, or mule is placed in it, be cleansed and disinfected as follows :

If the animal is accompanied by a written declaration that it is intended for exhibition or other special purpose, and has not been exposed to the infection of disease,† then the floor and parts soiled by evacuations shall be scraped and swept, and all scrapings, litter, etc., after mixing with quicklime are to be effectually removed ; while the sides of the vehicle, where any discharge from the mouth and nose of the animal can come in contact, shall be washed.

If the animal is not accompanied by the declaration above mentioned, the vehicle in addition to the routine mentioned in the previous paragraph, is to have the floor scoured with water and a coating of limewash applied.

A truck used for animals shall on every occasion after use be cleansed and disinfected by the collection of all excreta and litter, scraping the floor and such parts as may be soiled by manure, the whole to be swept up, mixed with quicklime, and effectually removed. The floor and sides are then to be scrubbed with water and limewashed.

Any van constructed for moving animals or equines by road and carried on a railway, shall on every occasion after a diseased or suspected animal or equine is taken out, be cleansed and disinfected on the same lines as a railway truck.

Any movable gangway used for loading or unloading on a railway shall after use be scraped, swept and washed ; the scrapings and sweepings to be mixed with quicklime and effectually removed.

Pens or other places used for the reception of animals before or after transit by rail, shall be cleansed and disinfected before being again used, either on the day of use, or not later than twelve noon the following day provided it is not Sunday, in which case it is deferred until Monday.

The pen is to be scraped and swept, and the scrapings and sweepings together with all manure and litter are, after mixing with quicklime, to be effectually removed. The pen is then to be washed with water, and a coating of limewash applied.

---

\* Animals here means all ruminating animals and swine.

† For the definition of disease within the meaning of the Act, see p. 480.

Under *The Water Supply on Railways Order of 1895*, Railway Companies are compelled to provide water for animals carried over their system.

### TRANSPORT BY ROAD.

The transport of animals by road is limited to those which are sick and injured, or suffering from infectious diseases.

Some fat stock are also conveyed in this manner to the show yard, owing to their inability to walk.

An ambulance for conveying animals may be on two or four wheels. It must be close to the ground, so that no great height has to be ascended in order to enter; the back must let down for this purpose and form a ramp. The shaft or pole should be capable of being unshipped, and the front let down, so that the patient can walk out.

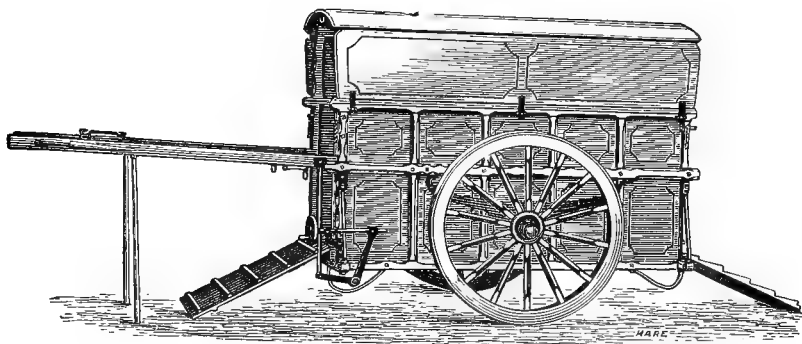

Fig. 215.—Ambulance for Animals for transit by road. There is a movable cover in this design, also a regulating screw lever for keeping the body of the cart level when travelling up or down hill (East Yorkshire and Crosskill's Cart and Waggon Co., Beverley).

Some ambulances are covered, but it makes them very close; a canvas cover on hoops could be employed in wet weather, otherwise it may be made open but with high sides. Two rings in front secure the head, and arrangements can be made for slinging the animal if desired, but this is very rarely necessary. The width of the ambulance need be no greater than that required to take an animal

comfortably—say, for a horse, three and a half feet clear inside measurement.

*The Animals (Transit and General) Order of 1895* provides for the disinfection of vans used for moving animals, horses, asses, and mules by road, on every occasion after a diseased or suspected case has been carried, and before it is again used.

The cleansing consists of removing all excreta and litter, and scraping the floor and other parts which have come in contact with the animal; these are next to be scoured with water, and then lime-washed. All scrapings, litter, and manure are then to be mixed with quicklime and effectually removed.

## CHAPTER XVI

### MILITARY HYGIENE

THE care and management of Army horses in peace only differs from that of horses in civil life in one or two particulars, such, for example, as their military training. It is not a hard life compared with that of civil horses, and it is only during the drill season and manœuvres that any severe work is done. The hardest part of the life of a troop-horse is the weight he has to carry, and he carries more during peace than during war.

Under the conditions of active service, the whole tenour of the life of the troop-horse changes. From living in a comfortable and hygienic stable with a warm bed, he finds himself in the open, exposed to wind, rain, sun, dust, frost or snow; from food of good quality and sufficient in quantity, he may find himself on reduced rations and poor of its kind; from work which is rarely excessive, he finds himself under the saddle all day and perhaps all night for days or weeks together.

In fact he is being tried very highly. The strain is excessive, the exposure considerable, food and water very variable in amount and quality, and work continuous.

In other words, the uttermost is being extracted from the horses, it is only a question of how long they can stand the incessant strain, and this length of time depends almost entirely on the care and management exercised.

It is when horses, in fact all army animals, are living under the most trying conditions, that the supervision should be the greatest and best. Every care must be taken to

husband the strength and maintain the vigour of the animals, and especially does this apply to horses, for they must not be found wanting when the supreme moment arrives which may necessitate their sacrifice.

The conservation of energy which we so strongly urge can only be brought about by officers, non-commissioned officers, and men knowing what to do, and possessing the needful resourcefulness. Resourcefulness can never be taught in any school; in the hard school of experience some facts may be accumulated even by men entirely wanting in resource, but they do not take the place of natural aptitude for adaptation to circumstances, and making the most of the conditions to hand.

The resourceful man knows no difficulties, they melt before him as they present themselves, while the man without resource stands paralyzed at nothing being to hand to meet his requirements.

Want of resourcefulness is the penalty paid for civilization; this thin veneer has to be cast aside entirely during war, and beneath it one finds either a better man or a worse; it finds the man who knows no difficulties, or the one who is incapable of overcoming the slightest obstruction.\*

The ordinary soldier cannot without supervision be trusted to look after his horse, and he is quite as incompetent to look after himself. Shifts and expedients are an unknown quantity to most men who have lived under civilized conditions, and who have seldom known what it is to even cook their own food.

If with a willingness to look after himself he fails, we cannot be surprised at the indifferent results when applied to the horse, an animal for which he has neither liking nor regard.

This dislike or indifference to horses is not characteristic

\* A volume might be filled with examples of want of resourcefulness in horse management during war. We shall be compelled, out of consideration of space and the limited interest of the subject to the general reader, to allow this matter to stand over for the present.

of the soldier, it is seen in civil life where nothing but payment by results insures the animal being looked after ; and for this indifference, dislike, and sometimes actual hatred of men for horses, there is only one creature to blame, and that is the animal itself.

The equine appreciates but is utterly incapable of reciprocating kindness, care, and attention ; affection has no centre in his cerebral organization, he has no love for man, and only occasionally for his own species. He is slavishly obedient, and is in consequence abused ; most forgiving, cheerfully forgetting an act of violence in the pleasures of the nosebag, and is therefore imposed upon. If he paid back every unwarrantable attack by immediate retaliation, men would no longer kick their horses in the belly for trivial faults.

Yet the same men who hate the slave that willingly carries them until it drops, will shower affection on a dog. No dog will ever leave soldiers of its own free-will, and no dog that joins a regiment will starve, be rations ever so short. The man who will not take the trouble to lead his horse 100 yards to water, or to feed him unless supervised, will share his rations with a dog ; yet from a practical point of view the one is nothing to him and the other everything.

The only explanation of this is that the dog is full of sense and affection, the horse possesses neither, and there are few people who can show liking for an animal when it is not reciprocated.

As a rule, neither in military nor civil life can we depend upon men looking after horses as the result of a friendship established between the two, though we are perfectly aware there are exceptions. Not even a man's care for his own safety will cause him to think of his horse ; apart from the absence of sentiment, this is due to lack of foresight and improvidence, the latter being the most universal feature in everything pertaining to the poorer classes.

Going back to the main point, the care of horses in war, we have stated that much of the neglect is due to a want of

appreciation of the element of personal responsibility, to an improvident disposition, to an utter want of resourcefulness, and to a dislike of the animal the result of its own stupid nature.

In the training of officers for the mounted branches of the Service, horse-mastership in its most practical and comprehensive form must be imparted from the first. They should be able to groom, make a bed, saddle, harness, and perform all stable operations like an expert; without this they cannot teach what they do not know. In the forge they should learn sufficient of shoeing to be able to put a shoe on—information of much more value than lectures or books on the subject. In the matter of saddles and collars they should be able to recognise the cause of most sore backs and sore shoulders at a glance, and know exactly what alterations should be made to enable the horse to work without further damage occurring; useful expedients to take the place of these alterations they should be able to make with their own hands. Not a single thing in the ordinary management of horses should they be ignorant of, and they must be just as capable of training them for military service as of riding them.\*

*Supply of Horses.*—Breeding horses specially for army purposes is talked of lightly by those ignorant of the subject. Anything more truly ridiculous cannot be conceived—as if the army horse were a special type of no use anywhere else! But, even apart from that, and granting for the sake of argument that he is a distinct type, how is it possible to find in any army the high technical skill and

\* We quite recognise that horse-mastership in the fullest sense of the term is only one part of the military education of the officer, which year by year is being added to and made more exacting. It is just as essential as his more purely military training, for without horse-mastership he may never have an opportunity of putting his military knowledge into practice. Further, he has plenty of time to learn it in; he is a long-service soldier, and it cannot be expected that a knowledge of the arts and sciences which go to make up the profession of arms, can be learned in less time than law or medicine, the groundwork of which takes at least five years to lay down.



profound experience which is required for one of the most delicate operations in nature? To learn the art of breeding requires a life-long apprenticeship, and this has to be grafted on a strangely intuitive knowledge possessed by very few men in a generation; yet, so profoundly ignorant is the public generally of the needful requirements for this delicate art, that the last boy from school is quite prepared to cheerfully accept the responsibilities of conducting a Government breeding establishment. Breeding consists in something more than bringing the male and female elements together, though this is the general standard apparently by which the matter is judged.

The supply of Remount horses in peace is not a very difficult matter, as only about 2,000 are required annually by the Army at home. It is otherwise in time of war, and the question then assumes an extremely important aspect; we may here glance at the system which has to be adopted in order to obtain horses, though the matter is not one which comes within the province of the Veterinary Department.

The first system is one which has its counterpart among men, viz., calling out the reserve. Under an enlightened and intelligent scheme devised by a late officer of the Remount Department, a capitation fee is paid annually to certain owners of studs, to enable in time of war a selection to be made of a certain number of horses at a fixed price. It is known as the Registration Scheme, and constitutes at a very low cost a permanent Army reserve, sufficient, in the first place, to meet any ordinary emergency.

The enormous advantage of the registration scheme consists in being able to obtain not only a large number of horses, but, above all, seasoned ones in hard-working condition, for in civil life horses are not kept to look at. No matter how technically unsound the horses may be, if they are in hard and regular work, the question of soundness or unsoundness need hardly be considered, provided they are moving practically 'true.'

We cannot, indeed, conceive a more admirable system

for the first supply of horses for a campaign—we say ‘first supply’ for the reason that only a limited number is obtainable; no firm can afford to register to such an extent as would paralyze its operations if the animals were suddenly withdrawn.

There is, however, one weak point, and that is the supply of riding horses. Obviously this is not the class employed commercially, excepting in the case of hansom cabs, while the number of patriotic private owners prepared to part with valuable saddle horses at remount price is necessarily small.

But, as a matter of fact, we do not consider that even this class would be difficult to obtain if the first essential element to success existed, viz., a horse census. Eighteen years ago, in the first edition of this book, we urged the necessity for an animal census. Some returns are available—for instance, horses used for agricultural purposes and brood mares, but this information is of no use for any practical purpose. It seems extraordinary that we, of all nations, should have neglected this very obvious information, which is really the basis of all large horse questions.

We should know how many of each age are living on any fixed date, their classification into draught and saddle, and, if possible, their sub-classification into heavy and medium draught, weight-carriers, or light saddle work. Thoroughbred stock should in these returns be kept quite distinct. With this information arranged in counties by the Board of Agriculture, there would be no difficulty in knowing where to look for the likely class of horse required. To obtain them when found, unless registered, is another matter, and might require special Parliamentary powers.

By whatever means the first supply of horses is obtained, the next essential step is to know where to obtain successive supplies, and here again the census returns would prove a valuable help for home purchases, while the Intelligence Department would have prepared the available sources of supply in other countries, and to these places would be despatched the purchasing staff.

Purchasers of army horses must approach the question in a practical spirit. Some tell us a cavalry horse should be of the hunter class, others look out for the activity of the polo pony, a combination of qualities of the utmost value, but how often can either the one or the other be obtained for the sum of £38?

*Stables at Home and Abroad.*—The general arrangement of stables in barracks has undergone immense improvements during the last forty years. Prior to that time the type of stable constructed is that which is seen in section at Fig. 95, p. 289, but the Barrack and Hospital Improvement Commission, which did so much to improve the sanitary condition of the soldier's life, was also the means of doing permanent good work in connection with horses.

The ground-plan of a stable shown in Fig. 117, p. 309, was devised by the Commission, and in fact the details we have given of industrial stables, p. 308, are based entirely on the recommendations of this Commission, which after 40 years' experience have been proved of permanent value.

Large cubic and superficial space, light, ventilation, impervious flooring, a double row of horses between opposite sources of air, and open-roofed stables instead of the men living overhead, were the outcome of this Commission.

There are no army stables in Europe superior in excellence of design and sanitary detail to these. Each troop horse gets 1,605 cubic feet of space and 100 superficial feet of area. The stalls are 5 feet 6 inches wide, 9 feet 6 inches in length, and the passage between the stalls 14 feet in width. The windows, of which there is one to each horse, are 3 feet 4 inches high, and 2 feet 6 $\frac{3}{4}$  inches wide.

Hospital stalls are larger; 1,900 cubic feet of space and 137 square feet of area are allowed, while the boxes afford 2,700 cubic feet, and 204 square feet of area. Each hospital stall has a window 2 feet 3 inches by 2 feet 6 inches over the animal's head, and a row of windows in the opposite wall; unlike the troop stables, there is only a single row of horses in the hospital stalls.

In India the stables consist of a roof, pillars, and a deep

verandah. There are no walls, the whole place is open, and no other type of structure should be used as stabling either in tropical or subtropical countries. The roof keeps off the rain and sun, the absence of walls maintains the circulation of air, while the deep verandah prevents the rain driving in so as to reach the horses.

The floors are of earth and require constant repair. A series of outside lines exist where the animals can be placed at night or any other time; this helps to save the stable floor.

The Indian stable cannot be improved upon, though the earth floors are a constant source of trouble from a sanitary point of view.

In South Africa the stables are galvanized iron and closed with four walls, perforated by large shutters which admit of good ventilation. Some of the stables have no such shutters, and are built on the lines of home stables, with only windows and ridge ventilation to keep them from being stuffy. This type is much too hot; all iron buildings are either hot or cold depending upon the season. Structural difficulties in dealing with sheet iron have prevented the walls in the South African stables being left open as in India.

The flooring is of concrete and cement, and the drainage surface, the urine being disposed of by the general drainage system into septic tanks, described on p. 370.

The mangers are of galvanized iron, and both this and the amount of wire in the country is a frequent source of wounds and injury, often resulting in lymphangitis. South Africa is essentially a country of iron houses and barbed wire, these take the place of wood which is practically non-existent.

The influence of stables on sickness is a point of considerable importance. Do we save life by placing animals under shelter from sun, rain, wind, and dust? With one exception we do not, and the exception is South African Horse Sickness, which is enormously influenced by shelter. In making this statement we do not include the period of acclimatization of imported animals, which in a

tropical or subtropical country feel the heat, and seek for shade nearly as much as man.

Once an animal is acclimatized, and is receiving the best of care and attention, living in the open in all weathers—heat, rain, cold, dust, wind, ground baked as hard as cement, or churned into a quagmire into which he sinks over his fetlocks—none of these make any difference to his general health. He feels, or at any rate looks, very miserable in wet weather but it does not hurt him.

Yet we would give cover to all animals as affording comfort, shelter from wind, rain, and sun, a dry standing, and no loss of forage such as bad weather in the open entails.

A roof and an impervious floor are all that is required for horses in any country, and though the remarks made above apply mainly to tropical and subtropical countries, this suggestion of a simple shed applies to all countries hot or cold. Walls are unnecessary if a verandah is used; while wind or driving rain can be kept out by means of canvas wind-screens attached to the verandah, and capable of being rolled up out of the way when not required. The temperature of the stable should never, even in the depth of winter, be more than a degree or two above that of the external air; in other words, the animals should live in the open but with none of the discomforts of this mode of life.

The effect of this on the skin will naturally show itself, but it is absurd to expect the same bloom and satin condition of coat seen in a civil stable where they are obtained through treating the animal as a hot-house plant, by keeping the stable at 60° F. and permitting two or three rugs to be worn.

A horse intended for war must live a more natural existence; feed him well, water him, look after him, and exposure in an acclimatized animal is borne without loss. Underfeed or neglect him, and the hardships above named at once accentuate the bad state of affairs.

*Hospitals.*—At p. 351 will be found a short description of the buildings and arrangements needed for a hospital, and for military purposes we have little to add to what is there laid down.

It is a mistake to place too many patients under one roof without dividing walls; a group of ten stalls is a convenient size. Box accommodation should exist for one-third of the sick. In a large hospital three or four of these boxes should be fitted with the most approved appliance for slinging horses, while arrangements both of water-supply and drainage should exist in the event of continuous irrigation being required. A foot-bath of concrete to accommodate the fore feet only is a valuable adjunct. 'Stocks' are a useful accessory to the operating appliances. The remaining essentials are dealt with on p. 352.

There is one extremely important duty of Hospitals in time of peace, viz., they should 'condition' their patients before they are sent back to work. It is obvious that after a case has been away two, three, or several weeks from duty, it is inviting further trouble if that animal is sent back to the ranks before being got 'fit.' No facilities exist in any regiment for conditioning horses after sickness, and when returned to duty there is nothing to prevent them being sent to a 'Field Day' at once.

Much of our trouble, with lameness especially, is due to this cause, and it should be regarded as part of the veterinary officer's duty to get the animal fit for work as well as to cure it. This may be effected by means of an automatic exercising track (to be presently described, see Remount Depôts), belonging to each hospital. In war this service should be performed by the Remount Department.

In South Africa the hospital consists of three blocks of semi-detached buildings, where possible arranged in line, and divided in such a way as to allow of the grouping of cases in hospital. Each section of stabling has an enclosure in which the patients may be allowed their freedom if desired, with water-troughs and manging. All the enclosures open into an exercising track, where the animals can be automatically dealt with.

The isolation buildings are quite distinct from the hospital proper. Fig. 216 shows diagrammatically the plan of this building.

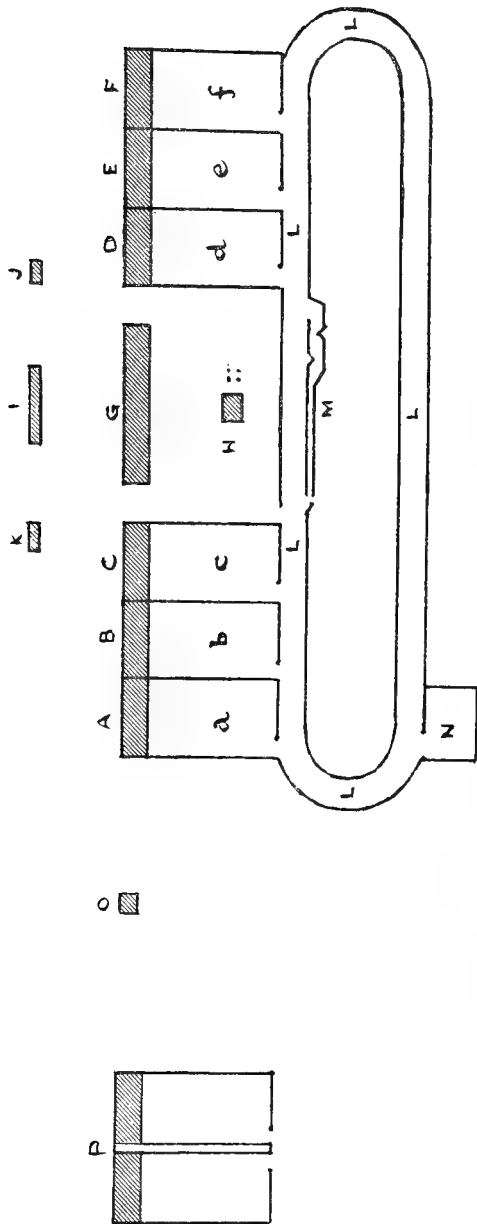

Fig. 216.—Diagram of Plan of Veterinary Hospital in South Africa. A, B, C, D, E, F, stables containing ten horses, each possessing its own enclosure, a, b, c, d, e, f; in the latter are mangers and water-troughs. G, the boxes; H, operating shed, with 'stocks' outside; I, office and stores; J, the forge; K, forage store; L, L, L, the exercising track; M, the 'crush'; N, watering enclosure for animals exercising; O, *post-mortem* shed; P, isolation stables. No detail is shown in this figure, and the accommodation for the hospital personnel is omitted.

*Military Training.*—The peace life of a soldier's horse consists of riding school, drills, field-days, and occasional show parades. Of these there is nothing which more solidly lays the foundation of future trouble than the riding school. The recruit horse on joining had until recently\* many months of this weary monotony in front of him, within the four walls of a roofed building, badly lighted, badly ventilated, where he saw nothing of the common sights of the road or field, and where he was taught to be an automaton. The influence of the old High School of Horsemanship of the 17th century still hangs to us, and horses are made to place themselves in unnatural attitudes, walk sideways like crabs, cross their legs, bend the neck and spine into a position never naturally assumed, and all this under the impression that the joints are being *suppled* and the horse made *handy*.

He is taught to move with chronometrical precision in a circle, the diameter of which is little more than the length of his own body; he is trained on the word of command to turn sharply at right angles to the path in which he is travelling, a movement absolutely unnatural in a four legged animal, and only possible with a biped. In the riding school he makes at the least four turns at right angles in every 130 yards, and is not allowed to round off corners but must take them squarely; the object of this being to make him 'handy' on parade and obedient to the rein and leg.

The effects of the above are to wear out the joints and lay the foundation of future unsoundness.

The essentials in the training of a military horse are :—

1. He must be used to strange sights, sounds, noises, cheering, music, guns, masses of men. These can never be learned in a Riding School.

2. He must learn to go by himself anywhere at any

\* In 1904 the first attempt to train horses on rational lines was started, the basis being the method of which the late Captain Hayes was the well-known exponent.



time. The instinct of gregariousness is so strong in horses, that the effect of working them together in a riding school is to produce a type not fifty per cent. of which will go anywhere by themselves, but always need a companion!

3. He must be taught to stand without being held when the man is dismounted, so that the number of horse holders in action is reduced, and the firing line in consequence strengthened. This training should be begun from the day of joining, so that the animal recognises it as part of his duty never to move when left standing alone; the time spent in teaching a horse not to require holding when the man is off his back is of inestimable value.

4. Horses do not require to be taught to move in a body; that is their natural method of life. Although in more than half of their soldiering they will be required to move in masses, inasmuch as they do this naturally no lengthy time need be devoted to its instruction; what requires to be taught and insisted upon is to move *alone*.

5. They require to be taught to change their legs in both the canter and gallop, and made equally handy with either the near or off leg leading. The object of this is to save a sprain when the leading leg tires (see p. 770).

6. He does not require to be taught to close to his right or left in the ranks, for his tendency is to hug or rub up against every horse he stands next to, or walks by the side of.

7. He must be taught to walk, trot, canter, gallop, jump, and stand firing, and the whole of this should be imparted in the open. No unnecessary turning on haunches to wrench the hocks, no frequent turning on the forehand to wrench the coronets, no acrobatic feats, but plain straightforward work, such as is expected from any horse.

The training of a cavalry horse should be individual not collective; he never requires to be taught to work in a mass for it is the delight of his heart, but he requires a lot of training to teach him to go by himself, to walk properly, and to jump. The latter must be done with the greatest care, and only when the joints are fit for the strain.

Jumping must be taught without a man on the back ; the horse must feel confidence in himself and know that he is capable of jumping, before he is handicapped by asking him to lift not only his own weight, but that of a ten or eleven stone man.

There are few things army horses hate more, or do worse than jumping, and with many it can be seen that they have not confidence in themselves, attributable in some cases to a previous accident when they may have blundered or fallen. A horse rarely forgets any difficulty he has experienced of this sort, and it makes him unwilling to face it again. At p. 814 it will be found stated that a horse is not intended to carry a weight on his back while a man is ; yet there are many men capable of jumping a certain height who would find considerable difficulty in doing so when handicapped with twenty or thirty pounds on their back, and this is about the equivalent carried by the horse. But apart from these considerations there are many horses which possess no aptitude for jumping.

A horse requires to be taught how to walk, it must be a good free stride, with no jig-jogging, wearing out his own legs and the man's seat. Few horses walk well, yet it is one of the things capable of improvement by education, the first principle of which is to give him his head and teach him to walk out with freedom.

The military training of a horse must not be hurried, the animal is young and growing, and like the recruit must be given time to condition and stiffen : there must be no forcing, no hurrying through. It is admittedly a peace training, because it would be impossible to devote this time to training horses in war. This peace training is not only to make the horse handy but to consolidate his limbs ; and this cannot be effected in a hurry.

The training for Artillery is mainly training for draught. At first nothing is carried but the harness ; as condition improves and no rubbing is evident, the gun limber is employed for hooking into. One great advantage possessed by the Artillery training of horses is that the young horse

can be harnessed with the old one, and thus learn his work. He can be let down lightly by being placed in the lead, or he may be kept under control by going in the centre, or his work may be greatly increased by going in the wheel.

Draught horses should not receive any riding school instruction; work in the open is what they require, learning obedience and to go over bad ground, being accustomed to strange sights and sounds, and getting shoulders hardened.

So long as horses join at four years old arrangements must be made to give them nothing but light work for a year, not that their training will take this time, but their limbs are not sufficiently knit for hard work.

Training in time of war is a very simple process, for the reason that it is impossible; the most that can be done is to have the horses ridden, to see they are moderately quiet and safe; it is bad enough to mount a man on a horse that has never heard a rifle fired in its life, without giving him an unmanageable one to ride at the same time. As a matter of fact the hardships of service are wonderfully steadying in their effects, and sober some of the most refractory animals, but certainly every horse ought to have been ridden before it carries a man into action.

The *Sanitation of Camps* is an important duty for the veterinary officer. Camps are of two kinds—(1) standing camps, which may remain for a month or a year, and (2) shifting camps, which may only be occupied a few hours. It is the sanitation of standing camps which is all important, especially as military necessity may require a close formation in the vicinity of an enemy, and considerable congestion of a limited area results. It may be accepted as a general principle that the horse lines of a camp under ordinary circumstances should be moved weekly; the amount of soiling which occurs in that time is considerable; the ground smells especially after rain followed by sun, and in wet weather the place is a quagmire. It is not the slightest use changing ground while rain continues, but immediately

a change in the weather sets in, the old lines should be evacuated and fresh lines opened. As soon as the old ground is evacuated it should be got ready for re-occupation; there is ample labour on service but few implements for cleaning up.

Resourcefulness, the sheet-anchor of soldiering, here comes in, and scrapers and sweeping material must be improvised; there is no difficulty about the latter if bushes exist, while the tin lining of biscuit boxes makes a useful scraper. The material is collected at the end of the lines, forage sacks being used in place of wheelbarrows, and the manure when dry enough can be burned.

The object of clearing the lines is not only to get rid of the filth, but to prepare the old place for re-occupation when the new lines get foul.

The manure should always be collected and burned, it both disposes of it, and in hot countries the smoke helps to keep away flies.

The water-supply on service is generally very unsatisfactory; rivers, streams, and ponds are the chief source of supply, while in standing camps wells are frequently sunk. On the question of water-supply in camp see the remarks made under this head in dealing with Stationary Veterinary Hospitals.

*Picketting.*—The ordinary method of securing horses in the open is by means of two ground lines, to one is attached the head-rope, to the other the heel-rope. Heel-ropes are not required when horses are doing regular work, they are generally too tired to kick, and may therefore be dispensed with. The worst line a horse can be tied up to is a ground line, it stretches, the pegs give way, and worse than all without heel-ropes the animal is liable to get its foot over the head-rope, and inflict severe injury to the heel.

This injury is known as a heel-rope gall, which is a misnomer, it should either be called a head-rope gall, or simply a heel-gall. It is a perfectly preventable injury, for even without a heel-rope a gall from the head-rope is impossible, if only it is not left too long. A head-rope of

3½ to 4 feet in length does not admit of the animal getting its hind heel over it, so that if horses are tied up with a rope which is not too long, they are perfectly safe without heel-ropes. There are few things more difficult to secure than this, simple as it is, while the injury arising from neglect of these precautions is excessive.

An air-line is far better than a ground-line; it is fixed at about three and a half to four feet from the ground, either by means of stakes, or by being secured to the wheels of a waggon. In the Artillery gun-limbers or waggons are used for the purpose and answer admirably. With this air-line no injury is possible from the head-rope.

A system of picketting by one fore leg to a ground-line has been successfully used; it has many advantages but has not been universally adopted. Eighteen inches of rope and a shackle around the pastern are all that are required. By this method the use of head-ropes is abolished, which in itself is a great advantage, as there is nothing which wears out so quickly or is so difficult to replace.

Known kickers should always be placed by themselves at the end of the lines, either secured by the fore leg system to a peg, or by a head-rope. The latter is not recommended, as without a heel-rope the horse walks round and round until he winds himself up like a clock-spring, and at the same time untwists the strands of his rope. A heel-rope will prevent this, but is not always available.

All pegs used for single horses without a heel-rope should be driven in flush with the ground, otherwise a serious accident may happen, the animal either lies on it, or rolls over on it, and penetrating wounds of the chest from this cause are by no means uncommon.

Horses on piquet or outpost are generally tied together, the head-rope of one passing to the head collar of the other, the process being known as linking. If startled they may go off with their heads tied together, but it is an accident which should not happen if the guard over the horses does his duty. The Italian ring, which is an ordinary ring

about the diameter of a stirrup-iron, may be employed for this purpose. Eight or nine horses may be tied to it with their heads in a circle, so that moving, though not impossible, is greatly restricted.

*Shoeing on service* is done cold with machine-made shoes; if forges are carried at the beginning of a campaign, they are sure to be left behind when transport through wear and tear becomes less. One fore and hind shoe are carried on the saddle with a complement of nails, and unless the wear is very heavy this is found sufficient.

If shoes run short they may be taken off the dead, and even the sick may have to give up their shoes to the horse at duty.

There is great difficulty in the proper care of the feet in the field. Often there is not time, sometimes no nails or shoes, frequently no rasps, farriers or shoeing-smiths may be sick, or even none left.

We shall touch on the question of the farrier and shoeing-smith presently, but here note that he does no more work than he is compelled to. Shoes are left to drop off, if the ground is easy going they are frequently not even replaced, and this largely results from the impossibility of shoeing being done often for days together, and the state of exhaustion in which men are when called upon to perform this class of work, at a time when they ought to be resting.

During *Marches* the place for the veterinary officer and his staff is in rear of the force or unit to which he is attached, and he should always notify where he is to be found. If the sick fall out of the ranks they stand by until the veterinary officer reaches them, and are brought on by him in the rear after being dealt with.

Dressings and remedies must be available, so that no delay is incurred. No veterinary chest can be got at as it is with the baggage, but a surgical haversack or wallet is carried by the subordinate staff, while in addition the officer carries his instruments.

Hypodermic remedies are useful at such a time, and

strychnine may help a horse to reach the next camp that might otherwise be left behind from exhaustion.

Very little can be done on the march in the way of treatment, and especially at night unless there is a moon, for lights are not available, and under certain conditions are prohibited.

The commanding officer who is anxious to husband the strength of his horses during marches, will dismount his men and make them lead their horses for a definite period every hour. There is nothing the men hate more; it is a proceeding which cannot be done in the vicinity of the enemy, but contact with the enemy is the exception and not the rule in war. When marching on foot occurs, the men must open out for ventilation and safety, especially if marching at night and on dusty or broken tracks. At night it is the only way to keep men awake and prevent them from tiring their horses by rolling about in the saddle.

At every halt, and especially the daybreak halt after a night march, horses should be looked round; if possible the saddle removed for half an hour, and shoes inspected. The removal of the saddle is an invaluable practice, and should be done every two hours when marching, in order to allow the back to dry and restore its circulation.

Every advantage should be taken of watering horses on a march, for one never knows in a strange country how long it will be before water is again met with. It is more difficult with artillery and transport than cavalry, for the animals have to be unhooked.

The transport of a force marches in the rear of it. With an army it may be so large as to extend for miles, even with a small force it is remarkable the amount of ground it covers. The officer in charge of transport and the veterinary officer should between them exercise the most constant supervision, riding both with and against the stream of waggons and animals, pointing out irregularities, rectifying misfits of harness or badly arranged loads, before they do any further damage.

The attention required is constant; one pace should be maintained, all trotting to make up intervals should be prohibited; the infantry protecting the convoy are certain to ride on the already overloaded waggons unless prevented; breaks put on going downhill are often forgotten to be taken off on the level; easy watering places are passed without taking advantage of them; temporary halts are not utilized for grazing when such is available, though to do this does not necessitate unhooking a single animal. The non-commissioned officers with the convoy continue to sit on their horses at every stoppage instead of dismounting; obvious galls are not immediately rectified by simple alteration in the harness; creaking wheels are not greased though grease is available, these and other matters are what should be looked for to insure the transport animals—the backbone of an army without which it cannot move—are kept in as fit condition as possible.

Here, for example, may be seen a pack mule loaded up in the dark with much more weight on one side than the other, causing the saddle to heel over and damage the withers; another carrying a few rifles, cooking-pots, and other impedimenta in addition to its legitimate load, in order to save trouble. There, perhaps, may be seen a mule with a portion of a machine gun so placed as to grind a hole in the withers, while another has some of the pack-saddle straps lying between the back and the pommel.

In a team may probably be seen a small willing mule in the wheel pulling his heart out, while a big one in the lead is not pulling an ounce. Here, perhaps, may be a string of camels, tied so closely head to tail that the rope does not admit of the naturally jerky movements of the head and neck, and the piece of wood to which it is attached in the nose is painfully pulled on by his fellow in front, and may even be torn out of the nose. Here may be seen a batch of sick or wounded animals tied up in groups of four or five, with a rope passing from head to head so short that all freedom of action is denied, and they lean on each other for support. Fig. 217, A shows the position, looked at from above, of



animals so tied up, which results in the skin being rubbed off the hips, while the centre horses are almost flattened by the pressure. Fig. 217, B shows that with a little longer connecting rope they can march in comfort without injury.

While daylight lasts the transport supervision must be kept up; at the halts it must still continue or animals will be allowed to go unwatered and unfed. Nothing, in fact, can take the place of the eye of the watchful officer, and when fully exercised it means the difference between neglect and efficiency.

The care of the transport must be largely left to the transport officer; Generals have their hands full of matters

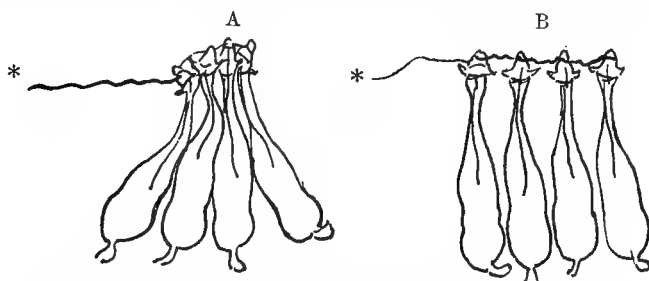

Fig. 217.—Method of Tying up a Group of Horses for Leading.

A, from its shape, might be known as the 'cartridge clip' method, and is due to the heads being tied too close together: it results in the most utter exhaustion from the lateral pressure each horse exerts on the other. B, is the common-sense method, which allows the horses to walk freely straight to their front, and with no lateral pressure.

The star in both figures indicates the position of the man leading the group; each group may consist of from four to six horses.

at the front. The transport officer should be the most highly trained and resourceful officer in the field; nothing should escape him; his first and last consideration should be his animals.

Neither men nor horses can fight on an empty stomach, and the officers whose successful management and organization have supplied them with food, cover, and often ammunition, with a minimum of wear and tear to the animals which have carried them, cannot be too liberally rewarded.

Selected veterinary officers should be attached to the transport; it is the hardest work in the field if properly

done, and comprises a knowledge of horses, mules, donkeys, oxen, camels, and elephants.

The *Food Supply* to the animals of an army in the field is met by the transport of grain and often forage, supplemented or replaced by local supplies.

It is no use talking of local supplies when operating in an inhospitable or unfriendly country ; in such, practically everything that is required will have to be sent from the base. When operations occur in civilized or partly civilized countries some local supplies are available, but seldom sufficient for a large army. If a line of rail exists no difficulty is experienced in supplying both grain and forage, while if no line of rail is available, and everything has to be carried on wheels, nothing more than grain can be calculated upon, forage being far too heavy and bulky ; so that the nature of the food supply depends upon the country where the operations are occurring and the transport facilities. Napoleon always made a country in which he was campaigning support the war by seizing all food for men and animals, but this admirable method of conducting war is not now approved of, and though in the heart of an enemy's country supplies can be seized as a matter of urgency, they are paid for in full. Veterinary officers requisitioning supplies or other stores should make an exact entry in their note-book of what was taken. A pencilled receipt handed to the owner may easily be manipulated.

From what we have said it is very little use discussing the food question ; everybody knows animals require food, no one has ever complained of the food supply being in excess of requirements, but it is frequently deficient from causes which are not under control and cannot be foreseen.

Every opportunity should be taken to supplement supplies from local sources ; fields of growing grain may occasionally be met with and utilized, care being taken to limit the amount, as a sudden change of food is harmful. The various millets and Indian corn may be used ; it has been known for a force to be very short of food for their animals, and unable to recognise a neighbouring field of millet !

Food supplies are often hidden on the approach of an army, the grain is generally buried, and anything in the shape of straw or forage hidden away; the roof of the house is a favourite place for the latter. The enemy is perfectly right to destroy food supplies; enormous tracts of grass country may be fired with this object, as was done during the late war in South Africa, which very successfully defeats the invader from using this important source of local supply.

Campaigns of starvation have not been unknown. Napoleon in Russia, Wellington in Spain, the Army of the Indus in Afghanistan in 1838, and the British Army in the Crimea, are notable examples.

Horses and other animals have to be fed if they are to be kept alive. As Nansouty remarked to Murat in the 1812 Campaign in Russia—when the latter was complaining of want of vigour in the cavalry charges—‘Horses have no patriotism; the soldiers fight without bread, but the horses insist on oats.’ A pound or two of hay and a handful of grain, can only have one termination.

Food may be available, but military necessity may not admit of giving animals time to eat it. A man can halt for a few minutes, consume his biscuit and beef, and be fit to go on; but this amount of time is of no use for any animal. It takes a horse at least five minutes to eat a pound of corn, and about twenty minutes to eat a pound of hay; at least five hours out of the twenty-four are required for feeding, and as he is fed in the hours of daylight and not in the dark, the bulk of the five hours is required to come out of the working day. And so with cattle; not only must time be given for feeding, but also for rumination. Without this they lose condition, and in time die from exhaustion.

In hot countries as much work should be done at night as possible. The animals at the front may have from necessity to work during the day, but there are convoys on the lines of communication which may be just as safe at night as in the day, while the work got out of the animals

is fifty per cent. better. This especially applies to oxen, which always work better out of the sun. By such a system the day is given to rest and feeding, and the convoy moves off in the evening both man and animal refreshed, and fit to go until the next morning.

Stragging is the only thing to be feared at night—seldom of the animals but frequently of the men, though that is an aspect of the case which does not concern us.

While feeding horses on service gives very little opportunity for selection, yet it affords every scope for the most rigid care and management. We believe it to be an underestimate in saying that one quarter of the hay and corn ration is lost, sometimes through sheer waste and indifference, sometimes from circumstances which are not under control, such as rain, and especially wind.

Nose-bags are at best a poor apology for a manger. Their life on service is a short one. Some horses will wear a hole in the bottom in a few days, through rubbing them on the ground in order to get them off when the feed is finished. A double bottom, or still better a piece of rope arranged crossways, would largely prevent this; but there is also the question of management, viz., they should be removed before the horse has time to rub them against the ground.

A nose-bag with a hole in it is like a purse with a hole in it. If those responsible for the care of horses would regard the grain ration as gold dust, they would take care of the purse containing it. We have no hesitation in saying that the enormous waste of grain on service is due to defective nose-bags, viz., to a condition largely under control, and, therefore, preventable. At immense cost and labour grain is brought thousands of miles, and when it reaches its objective it trickles in a thin stream on to the ground and is lost, while the most ordinary common-sense precautions could prevent it.

At the same time, we fully acknowledge the nose-bag is defective. It is always too small, which in itself causes waste when the horse throws his head up, as many of

them invariably do when feeding. It does not allow sufficient air to enter at the top. These defects are easily remedied, but we would like to see a nose-bag capable of taking hay as well as corn ; one in the shape of a long bag secured around the neck, and passing to the head (introduced some time ago into civil life) would appear to be on the lines required, though we have no practical acquaintance with it.

Forage biscuits for use in time of war have been frequently made, but they are a failure, as might easily be predicted from a knowledge of the physiology of 'feeding.' The horse is not constructed to live on concentrated food ; he must have bulk. If whole oats and crushed beans could be compressed into a cake and sewn up in canvas it would make a useful emergency ration and reduce the bulk carried ; but there is no such thing as concentrating the food in the sense in which this term is generally employed. If the above cake weighs one pound then at the least ten of them a day will be required to keep a horse going, with such grazing as can be got.

It will be observed there is nothing of the nature of concentration about this cake, there is no reduction in weight ; it is simply a useful means of carrying compressed food, and would save considerable waste, sufficient, in fact, to pay for the compressing and canvas cover.

Bales of compressed forage are admirable, they usually contain chaffed hay, oats, and straw. Crushed oats in compressed cake frequently turn sour, so that only whole oats should be employed.

In speaking of the transport of horses by sea we laid especial stress on the use of hay nets in preventing waste. The same holds good for horses in open camp or bivouac, only a hundred times more so. It is perfectly impossible if any wind is blowing, to give hay in the open in any other way than by means of a net, without incurring a loss of at least half the material. The hay net is tied to the picket line, and no waste can possibly occur. A good large nose-bag, well protected from injury, and a couple of good close-

meshed hay nets, are as essential for horses on service as ammunition is for the men.

In the standing camps of Field Veterinary Hospitals, mangers of either canvas, galvanized iron, or wood may be erected. Canvas mangers are not very successful, but are easily carried, and are the next best thing to wood or iron mangers. Their defect is they 'sag' at the centre, and the food naturally gravitates to that part, so that the ration is not equally distributed among all the horses.

Sheets of corrugated iron placed on a low wall made of mud and stone form a very fair manger, and keep the food clean. The corrugations save loss. Each sheet of iron has to be firmly pegged down to the wall, or accident will occur.

The saving in food by the use of mangers can only be believed by those whose duty brings them in contact with this class of work. Mangers pay the cost of their construction in a month by the saving of forage and prevention of disease. They may be made of plain or corrugated iron—the latter is stronger—bent into half a circle, and secured to a frame with good trestles. They should be kept ready-made in store, as part of the equipment of an army, for use at the base and on the lines of communication.

In the same way water-troughs should be kept ready for issue. Wooden troughs are very wasteful; they leak at the joints, and also at the tubes where they are coupled up with the other troughs so as to form a long line. Metal troughs are the best in every way. But whatever method is used, whether of canvas (which is more wasteful than wood), wood, or iron, the supports must be strong and substantial, owing to the great weight they have to withstand.

In the absense of nose-bags horses may receive their grain ration off the saddle blanket—in fact, the care taken to keep the grain from getting mixed with dirt on the ground cannot be too rigidly exercised.

*Animal Losses in War.*—The loss of horses and other

animals in war is a most important subject. Before our last great struggle in South Africa we published papers on this subject,\* in order to attract the needful attention to those sources of loss which were under control. Such extracts from these as specially bear on the subject we are now considering will be reproduced.

Speaking roughly, of every 100 horses sick on service:—

25 will be suffering from exhaustion or debility.

25 from sore backs and other forms of preventable wounds, such as rope galls, bit injuries, etc.

25 from mange.

25 from other causes, of which lameness will predominate.

It is obvious that the object of this tabular statement is rather to fix attention on the principal causes of sickness, than to state the exact proportions in which they occur.

It will be convenient to separately consider each of these causes.

*Exhaustion* may result from starvation, from insufficient food combined with too much work, or it may occur in the midst of plenty where horses are being worked incessantly without rest, or at such a fast pace as to kill them. Exhaustion may occur in time of peace; there is no regiment that does not possess a certain number of horses that after a hard field-day go 'off feed,' probably for two or three days, until the effect passes off. The life of such a horse on service is necessarily a short one; if he cannot eat he cannot work, or if he has to work in spite of not eating his days are numbered.

But whether food be liberal, sufficient, or insufficient, no animal can produce an unlimited amount of work; everything over and above a certain useful effort means wearing

\* 'Saddles and Saddlery': Lecture, Aldershot Military Society, July, 1891; 'The Loss of Horses in War': *United Service Magazine*, August, 1893; 'The Loss of Horses in War': *Journal of the United Service Institution*, vol. xxxviii., 1894.

out the machine, and some of them wear out very quickly. Where important military operations depend upon a certain movement being made at all costs, the results must compensate for the sacrifice; but it is within the knowledge of history that enormous efforts have been demanded from horses not followed by any useful result, for when the psychological moment arrived the horses were done up. For example, at the Battle of Borodino the charges of the French cavalry against the Russians were executed at a slow trot. Some of the most important results in a campaign may be entirely lost through an inability to reap the effects of victory. If artillery prepare the way for victory, and infantry win it, it is cavalry that collect its fruits, and consummate the destruction. If cavalry are so exhausted they can move no quicker than infantry, the defeat of an enemy becomes a carefully carried-out dignified retirement instead of a rout, and the whole process will again have to be repeated.

There is a great art in skilfully throwing away lives whether of men or horses; it is part of the extremely rough game of war, and has to be faced. It is not this which produces the loss of horses in war, but the inexcusable wastage which occurs under subordinate commanders; galloping when a quiet canter would suffice, trotting when the work could easily be done at a walk; failing to dismount the men at every available opportunity; failing to make them walk in order to ease their horses' backs; failing to take every opportunity for watering and feeding the animals.

It is perfectly simple in a very few hours to exhaust horses on these lines; when we speak of the loss of horses in war, how few realize the enormous control the junior officers can effect in this direction, by bearing in mind (1) that a horse is not a machine but living flesh and blood, (2) that every cavalry horse is carrying a weight which is not represented by one man but by very nearly two!

It may be stated as a general rule (to which there are exceptions), that no horse or mule in the army which is not under the eye of an officer receives any care, and



the reasons which influence this have been discussed earlier in this chapter. Strange to say this has been the history of our army for a hundred years, and probably longer.\* Burgoyne tells us that in the Peninsula the difference in care bestowed on their horses by the British and German Dragoons was most noticeable; both horses received the same forage, were with the same force, while the difference in condition and fitness for work, was due to the greater care bestowed by the Germans, who could always place 100 horses in the ranks to our 10. Mercer also, strange to say, drew a contrast between the German and British Dragoon, and says the difference in the affection for and care of the horse is what distinguishes the two: 'while the former would sell anything to feed his horse, the latter would sell his horse itself for spirits or the means of obtaining them. The one never thinks of himself until his horse is provided for, the other looks upon the animal as a curse, and a source of perpetual drudgery to himself.' Wellington throughout his Peninsular despatches deplures the loss of horses. In one despatch he says, 'It is inconceivable how fast both the horses of the cavalry and artillery fell away. When horses as well as men are new to war, *I believe the former are generally the sacrifice of their mutual inexperience.*' The italics are ours. The sentence shows what was in the Commander-in-Chief's mind.

Returning to the two vitally important points to be borne in mind by all officers of cavalry, especially junior officers, it is but fair to them to state that the assumption is that their horses are in condition for work, or if not, that they understand how to get them in condition and have the time to do it.

General Hartmann's Cavalry Division in the War of 1866 marched 16 miles to the Battle of Koeniggraetz, was engaged for ten hours with the enemy, and in pursuing the retreating Austrians marched 97 miles in three days; it cost the Division 25 per cent. of its horses, but the animals

\* See 'Military Opinions,' Field-Marshal Sir J. Burgoyne; 'Diary of the Waterloo Campaign,' Major Mercer, R.A.

must have been in excellent condition for it to have come off so lightly. An Artillery officer\* who went through the Corunna campaign, records that his battery marched in mid-winter 34 miles through deep snow over the mountains without halting a minute, and that for 145 miles not an hour's halt was made during any day, merely resting a few hours at night. These horses must have been very fit to have undergone this exertion. The only casualties Captain Wall speaks of were sore shoulders from badly-made collars.

Here is a final example of what conditioned horses are capable of doing. In the campaign of 1866, the 5th Cuirassiers of the Prussian Army marched 200 miles in seven consecutive days, often bivouacking in heavy rain; they came in contact with the enemy at Tobitschau, charged their artillery, drove back the cavalry support, and captured 18 guns, 400 prisoners, and 157 horses.

*Sore Backs.*—The next heavy source of loss is sore backs; these have always accompanied every army that has taken the field, though strange to say no attempt has been made to record the number.

The causes generally operating in the production of sore backs have been fully dealt with at p. 811, what we have to inquire into here, are the special causes in operation in military service. These causes may thus be classified:—

1. Uneven or irregular pressure on the back.
2. Want of condition and loss of muscle.
3. Dead continuous pressure, and want of balance in the weight carried.
4. The saddle resting on parts of the back not intended to carry weight.

A military saddle has to be made very heavy and strong in order to carry the weight placed on or secured to it. Every part of the saddle with the exception of the flaps is capable of producing injury. But it is only fair to say if no portion of the saddle was capable of producing injury, yet a proportion of sore backs would occur from dead continuous pressure.

\* Capt. Wall, *Proceedings Royal Artillery Institution*, vol. xiv.

Let us, therefore, first inquire into this dead continuous pressure so destructive of military horses.

A cavalry horse carries nearly the equivalent of two men of average weight, and this weight may be divided into living and dead; obviously the living weight is the man, the dead weight consists of the saddle, arms, accoutrements, ammunition, kit for the man, and rations for both. Fig. 218 shows diagrammatically the weight carried by a troop horse. It would almost appear as if the troop horse were to be considered some special act of creation for military purposes,

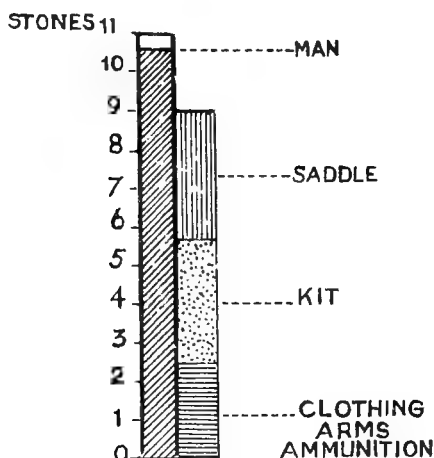

Fig. 218.—Diagrammatic representation of the Weight carried by a Cavalry Horse.

otherwise it is inconceivable that anyone could imagine an ordinary horse could carry the above  $19\frac{1}{2}$  stone day after day, especially on short rations, insufficient water, short rests, and over broken ground.

Yet this supposed special product the troop horse has to do it, as if the fact of being a soldier's horse gave him supernatural strength and energy.

We have at p. 773 gone into the question of the weight-carrying powers of the horse, and have shown that 15 stone is the maximum which should be enforced. The Emperor Theodosius had evidently a keen appreciation of the weight-carrying powers of his cavalry, for in the Theodosian Code,

A.D. 385, is a rescript which confines the weight of the saddle and bridle to 56 lbs., and orders that the cloak bag, which presumably contained the spare kit, should not weigh more than 35 lbs., the cloak bag to be forfeited and the saddle broken in case these orders were disobeyed. The Roman saddle and impedimenta weighed 6 stone 7 lbs., while our cavalry saddle and impedimenta weigh but one pound less. The reduction of one pound in weight in 1,500 years is not very creditable.

The Man-at-Arms in the reign of Henry VIII. rode a few pounds short of 26 stone, but he rode a cart horse which he only mounted when he came into action, and the length of his charge was under a hundred yards. The German Cuirassier is shown by the official handbook published by our Intelligence Department to ride 23 stone, and though we have given 19½ stone as the weight carried by our cavalry this is the minimum, while many horses are carrying 21 to 22 stone.

On this matter we have nothing to add to what was written eight years before the war in South Africa occurred.\*

‘I feel I have said enough on this point; the error we are making must be patent to all. I protest most solemnly against the crushing weight a horse has to carry, and leave it to the combatant authorities to decide in what way it can be reduced if cavalry in the field is to remain efficient for any length of time. As matters stand at present, it would not be a very difficult calculation to ascertain how many horses free from sore back would remain to us, say out of our 1st Army Corps, after a three months’ severe campaign.

‘If we can afford to kill off these horses by having others to replace them so well and good; as a matter of fact, we know that to replace them is an utter impossibility. Let us deal with this question while we can. We all believe there is a great future for cavalry in our next campaign, that future they will never see unless the question of saddles and weights are settled in favour of the horse. . . .

‘We are bound to recognise a cavalry horse must be capable of undergoing severe exertion; if he sinks under it it is his fate; it cannot be helped; if he gets a sore back through it in the majority of cases it

---

\* *Op. cit.*

is neglect or ignorance, and these are preventable. *Reduce the weight, this is the panacea for sore backs, this is the secret of efficient cavalry.*'

Among the causes of sore back which are tabulated at p. 962 is want of balance in the weights carried, and the fact of the saddle bearing on parts of the back not intended to carry weight. At p. 816 we have dealt very fully with the question of blade bone and loin pressure; a troop horse carries 22 lbs. 6 ozs. over the scapula, and nearly 13 lbs. behind the saddle. On the near side of the horse is carried  $16\frac{1}{2}$  lbs., on the off side  $13\frac{1}{3}$  lbs.

So the tendency of all this weight in front, plus the side bars of the saddle resting on the blade bones, is to impede the movements of the scapula more and more; while the fact that more weight is carried on one side of the saddle than the other, necessarily causes a heeling over with greater pressure on that side, and destroys the even distribution of weight.

It is obvious from what has been said in this and previous chapters, that nothing should be carried on the horse but the man, his rations, and his arms. This would mean that a light saddle would be sufficient for the purpose, while whatever is required for the comfort of the man must be carried in some other way, and the only other way suitable for cavalry is by means of a second horse.

In future campaigns the cavalry which have a second horse for each man will be the victorious cavalry. Every officer in the field has a second, sometimes a third charger. The horse that carries the impedimenta to-day carries the rider to-morrow, and so it must be for the men; every man must have two horses. There is nothing new in this suggestion; it was always so in the days of armour, even when it became much lighter. Cruso in his 'Military Instruction for the Cavallerie,' 1632, tells us that the cavalier had 'a boy and a nagge to carry his spare arms, and oat, and sac, and get him forreage.' The word 'sac' here means something corresponding to our valise, for in the 'Souldiers Accidence,' published by Markham in 1643, it is described

as his 'necessary sackage of carriage.' In fact, so far as our inquiries go, there is nothing to indicate the cavalry carried anything on the saddle until after the middle of the 18th century.

History will have to repeat itself in this as in many other things. The present air line so largely used for the tying up of horses in camp (p. 949) was employed by the French cavalry before 1750; and our cavalry will have to come back to a spare horse for each man, on which will be carried the lightest of kit for the man and rations for two horses. It was this system which enabled the Boers to move in the way they did during the late war, and some of their men had three horses.

This is no place to discuss the question of how these spare horses are going to be led or driven; they will have to be tied up in groups, and it is hoped the object lesson figured at p. 953 will not be forgotten.

*Glanders* as a source of loss on service does not figure in the table on p. 959, as this only represents existing sickness. The disease is generally speaking rife, and the larger and more extended the operations the more is it spread. The rule to adopt during war is to destroy only the clinically affected; nothing can be done to stamp the disease out until the campaign closes. On this subject see the remarks later on in connection with mallein.

*Mange* as a cause of inefficiency is very serious; it is quite true a mangy horse may be worked, but it certainly should not be placed among horses free from the disease. There should be no difficulty in making up a mangy squadron from a regiment, but to prevent the disease spreading is impossible until the horses can be spared for treatment.

There is nowhere that mange will spread so quickly among military horses as in a railway truck and on board ship. The only possible attempts at isolation that can be made for a regiment affected with mange, engaged with or in contact with the enemy, is that mentioned above; when the emergency is passed, the majority of the cases will find

their way to hospital, fresh horses will take their places, the same saddles will be placed on these, and the result can be imagined. Nor is it possible on service to prevent this sort of thing occurring. Disinfection of saddles, blankets, etc., is difficult enough in time of peace, almost impossible on service both from lack of material and facilities. Still, if the disinfectant exists, the plan suggested at p. 410 is the only one to adopt for the blankets, while the saddlery may be steeped for a short time in the same bath.

*Lameness.*—The most common seat of lameness on service, as in peace, is situated in the foot; the most common foot trouble is laminitis, but quittors from injured coronets and neglected suppuration of the foot are very common and extremely unsatisfactory.

The *Loss of Horses under Fire* is always greater than the loss of men, due to the fact they present a larger target. We made an examination of this question some years ago,\* taking all the available figures during the 179 years prior to the Battle of Sedan; this period was divided into three groups corresponding with the change in firearms, and the following facts ascertained:

During the period 1691 to 1799, for every 100 cavalrymen disabled there were 148 horses.

During the period 1800 to 1865, for every 100 cavalrymen disabled there were 121 horses, and for every 100 artillerymen there were 133 horses.

During the period 1866 to 1870, for every 100 cavalrymen disabled there were 141 horses, and for every 100 artillerymen there were 133 horses.

In the examination of the above figures the killed, wounded and missing are included in the term 'disabled'; it is unfortunate that through the number of horses actually present at the engagements not being stated, it was found impossible to give a percentage due to losses under fire. In memorable losses, such as the Charge of the Union and Heavy Brigades at Waterloo, of the Light Brigade in the

\* *Op. cit.*

Crimea, and the 'Death Ride' at Mars-la-Tour, the percentage loss is known. The mean cavalry loss in horses at Waterloo was 38 per cent., in the cavalry charges 54 per cent.; at Balaclava 50 per cent., at Mars-la-Tour 51 per cent.; these three charges agree very closely in the number lost under concentrated fire, though historically they lie so far apart.

In the field veterinary hospitals will be found a certain number of cases of bullet wounds; only those situated deeply in the muscles of the quarters are likely to give trouble. Many of the wounds received on the field kill outright, or inflict such considerable injury that the animals never leave the field, so that a veterinary hospital in war contains a minimum number of injuries specially due to fighting, and a maximum of those which are generally regarded as preventable.

*Defective Shoeing* has always been a serious source of inefficiency; it is impossible to keep horses shod up on service that are moving daily, and the system whereby farriers and shoeing-smiths have to take their place in the ranks as ordinary trained soldiers, and then set to work to shoe at the first halt while the other men are resting, is not a very helpful one to keep horses' feet in order. The farriers and shoeing-smiths should move with the baggage, and be kept as fresh as possible, so that on arrival in camp they are moderately fit for work, for all marching is tiring. Shoes lost while the regiment is on the move should be replaced by the 'cold shoers,' of which there are a certain number in each squadron.

It seems a most extraordinary system to expect farriers and shoeing-smiths to do their work in the ranks as soldiers, and then set to work shoeing when they need rest. The farrier is a valuable man in the care of horses' feet, and should have his strength and energy conserved for the work which awaits him at every halt.

In every campaign the cry is for farriers, yet the system we adopt is one which uses them up. It was the same in the Peninsula, the farriers could not do the amount of



work required, in consequence of which Wellington recommended the ready-made shoe for military purposes, another example of history repeating itself.

The loss in General Hartmann's Cavalry Division mentioned at p. 961 was largely due to the impossibility of keeping the horses shod. The Corunna campaign is the best example in our history of defective shoeing, for there were neither shoes nor nails; the same thing frequently occurred during the American Civil War.

The absence of frost-shoeing was partly responsible for some of Napoleon's disasters in 1812, for the sufferings of the Danish Army in their retreat from the Prussians in 1865, and according to the French it helped to determine the capitulation of Bourbaki in 1871.

Shoeing would be greatly simplified on service if farriers were struck off all other duties; in fact, the only thing required to render shoeing efficient is to have a sufficient number of farriers, and confine them solely to their trade.

Apart from the loss of horses under fire, the heaviest losses in animals occurring to any army is during a retreat. Out of the 160,000 cavalry which entered Russia in 1812 only about 1,600 recrossed the Niemen six months later, the loss being over 97 per cent. In our retreat on Corunna the cavalry losses were about 50 per cent. In a retreat of the Portuguese cavalry in the Peninsular Campaign the loss was 42·6 per cent.

In Wellington's retreat from Salamanca to Ciudad Rodrigo he lost one horse for every mile traversed, while Massena in his retreat from Portugal, lost in the ten days it lasted as many horses as during the previous two and a half months' campaign.

It is obvious that the chief cause of loss in a retreat is due to exhaustion.

*Stampedes.*—One would have thought that war brought quite enough damage without horses inflicting losses on themselves, but whenever bodies of horses are brought together, the curious contagious nervous explosions known as stampedes are liable to occur. We have dealt with this

question at p. 793, but as affecting Army horses and losses in the field it presents the most important aspect, for a regiment of cavalry minus its horses is not of much use, while if their animals have gone over to the enemy they may be invaluable.

The two most common features connected with stampedes are that they generally occur in the dark, and almost invariably as the result of a sudden noise, which may vary in degree from a heavy thunderclap to a single rifle shot. But any sudden noise, whether they can recognise it or not, may produce the same effect. A regiment has stampeded through the men suddenly cheering. There is one feature common to all stampedes, and that is the horses are under no control at the time it occurs. No one has ever heard of the horses of a regiment stampeding with men on their backs, and this fact tells us the steps which should at once be taken to try and cut a probable stampede short, viz., the men should at once stand to their horses; this is easy enough in a bivouac, but much more difficult when the men are in tents. The trumpet call for 'feed' has been sounded with success for a small party of runaways, but if these measures succeed they will be phenomenally lucky; as a rule the horses go off in one mass, as if the whole thing had been carefully arranged beforehand.

Line gear cannot be too good or too secure, and especially should this be looked to in wet weather, when pegs are easily drawn. A body of horses which has once stampeded is very liable to a recurrence until the affair is forgotten.

*Total Losses.*—An examination of the total losses likely to be experienced by an army in the field, led us some years ago to place it at 20 per cent. every three months, and though this was enormously exceeded during the late war in South Africa, we are not inclined to regard the estimate as seriously wrong. It might be safer, perhaps, to say that one quarter of the entire number of horses engaged will have to be replaced every three months, and in spite of the South African figures, we believe this

estimate for animals entering on a campaign in a condition of fitness will not be exceeded.

This matter of 'condition' is the crux of the entire question, and leads us to examine the methods by which condition can be obtained in the simplest possible manner among a large body of horses, and how their management may be systematized so as to render the reserve horses of an army in the field being made and kept fit, with no loophole for neglect in their general system of management.

This scheme\* has been practically employed in a campaign, so that it cannot be consigned to the realm of theory, while the practical results impressed all who had an opportunity of observing what method, system, and intelligence are capable of producing.

As the reserve of horses in the field are held on charge of the Remount Department, we may fitly describe the following as the organization of a Remount Dépôt in time of war.

#### ORGANIZATION OF REMOUNT DÉPÔTS IN WAR.†

On the outbreak of hostilities, among the first transports allotted after the departure of the Field Army, should be that for the Remount Department; this ship should carry the entire remount staff, and material for the erection of a dépôt on landing.

The material required is portable light shedding of galvanized iron, to accommodate 1,000 horses, with mangers, water troughs, posts, gates, wire for erecting enclosures, pumps, waggons, etc. Accompanying it is a staff of qualified artificers, viz., 20 farriers and 10 carpenters, capable of putting it together in a few days, with such native labour as is obtainable at the base of operations.

Until accommodation is provided for the reception of

\* Devised by Major Eassie, D.S.O., Army Veterinary Department.

† Specially written by Major Eassie for this Manual, and for which I am extremely indebted.

the horses, it is no use sending remounts to the seat of war.

There is only one scheme of construction and organization which is economically possible; it must provide—

1. For the reception of a ship-load of animals, their inspection, and sorting.

2. It must afford these animals the needful rest and comfort after a tiring journey by sea or rail.

3. It must provide for the watering, feeding, and exercise of a very large number of horses, with a minimum amount of labour.

4. It must insure that the three above essentials in horse management are carried out with regularity and precision.

5. It must embrace a system by which animals are 'conditioned' after their voyage, with a minimum amount of labour and a maximum of efficiency, and their feet got in thorough order.

6. It must be a system which admits of facilities for the detection of disease, inspection of individual horses, and their isolation.

The scheme to be described is one by which the horses are practically taught to look after themselves; only a small number of attendants are required (which is of immense advantage on service where every man is required for the fighting line), and the horses are thoroughly well done. Any scheme which admits of 1,000 horses being exercised, watered, and fed, in less than an hour by 48 men, is one deserving of attention.

Before describing how this is brought about, it is desirable that the mainspring of the whole mechanism be examined, and on this point let it be at once said that what is about to be described is no theoretical or fanciful scheme, but one actually used for more than two years during a campaign, in which time it dealt with over 50,000 horses, or a daily average of over 2,000.

Two years afforded ample time to elaborate and perfect the system employed, and this is mentioned for the reason



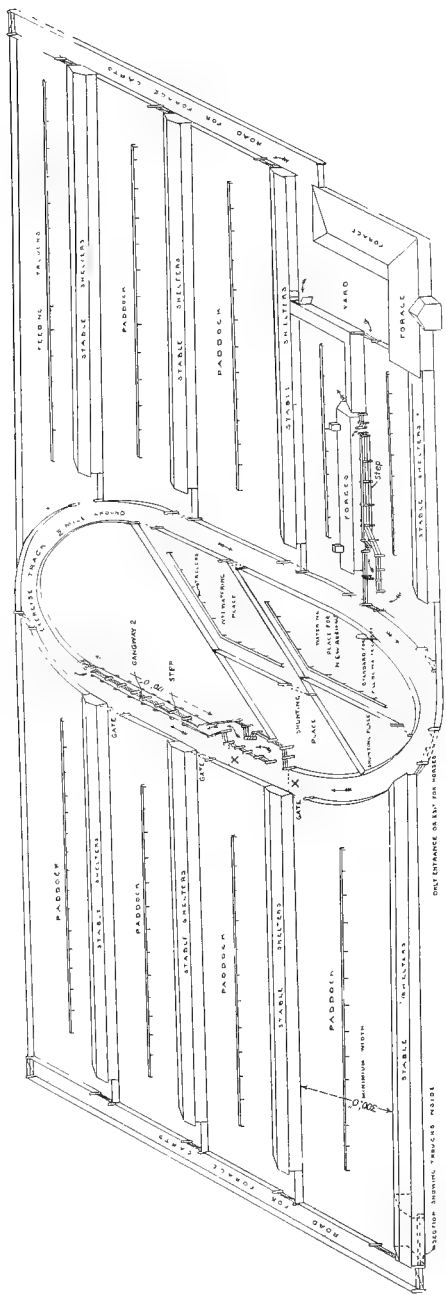

Fig. 219. — Isometrical Plan of a Remount Depot described in the text (Drawing not to Scale).

x x, Position of gates which close across the track and enclose a section of the track (see Fig. 221, Plan of Crush).

To face p. 373

that the complete success of the scheme depends upon the details yet to be described being thoroughly carried out.

It is assumed that the best available site is chosen for the depôt, viz., on sandy ground, with sufficient fall for storm drainage, and proximity to water-supply. Given these conditions, the existence of the building material and staff to erect it, the production of a Remount Depôt which practically runs itself, is only a matter of a few days.

The mainspring of the mechanism is the proper arrangement of the ground-plan; no matter whether the depôt is to accommodate 500 or 5,000 animals, the basis of the system is the exactitude with which the instructions herein laid down are followed.

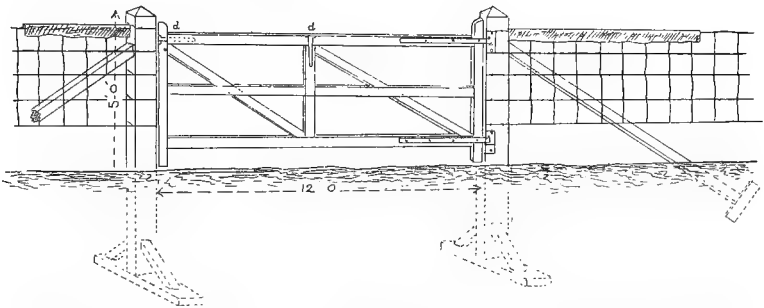

Fig. 220.—Showing type of wire fencing for Remount Depôts, also method of supporting the uprights for the gates and other main posts. Where 20 foot gates are used they should be in two halves.

The first thing to be marked out is the exercising track (Fig. 219). This is an irregular circle capable of exercising 250 horses at one time; the circumference of the circle is about half a mile, and the width of the track 30 feet. This track is enclosed by either ordinary park fencing, or by wire fencing. Both are readily put up; if the latter is used the pattern shown in Fig. 220 should be employed, as it is time-saving in erection and strong.

Communicating with the exercising track by means of gates are certain paddocks or enclosures, each capable of holding 250 horses, and within the area bound by the exercising ring are enclosures where the horses are watered.

These watering enclosures do not communicate with each other, but they all communicate with the exercising ring, and each is provided with a shunting place, the use of which will appear later.

A paddock for 250 horses possesses the following measurements: length, 600 feet; breadth, 300 feet. On one side of it is erected light shedding, intended to protect from the sun or rain, but in which the animals are never tied up, they go in or remain out as it pleases them. There is manging in these sheds for use in bad weather, but under ordinary circumstances the horses are fed outside.

Down the centre of the paddock runs 400 feet of double manging, that is, mangers of double width, sufficient for 250 horses to feed with comfort.

The mangers are on wooden trestles, and in sections no longer than 20 feet for convenience of transport. The trestles get a good hold in the ground and render the thing secure.

Plain and not barbed wire fencing is employed to enclose the entire depôt, which has only one entrance gate, viz., the one leading to the exercising ring.

A word may be said about the fencing; if wire strands are used never put in the bottom strand, horses get their feet over it and sustain severe injury to the coronet or heel. The fencing should be 5 feet from the ground, and there should be nothing in the shape of wire nearer than 18 inches to the ground.

The posts to which this is fixed must be well let into the ground, and be provided with side pieces, as in Fig. 220, to give them a good hold in the event of any strain being imposed on the fencing.

Uprights simply driven into the ground are not strong enough; time expended in putting up good firm uprights on which to stretch the wire fencing is well spent.

Horses do not see wire well, and to enable them to recognise the limit of the enclosure a piece of galvanized iron is fixed to the top strand and bound on to it like a cornice (Fig. 220). It is white-washed to catch the eye.



In the enclosures the horses are perfectly free to roam about as they will, they rest if they wish it without disturbance, and if the soil is sandy as it should be, they get all the grooming they need. Sand is an excellent thing for cleaning the skin. As a matter of fact, owing to the sand-bath, and the regular and sufficient exercise, it is found that after a time they carry perfect coats, and the mane and tail are entirely free from scurf.

The description of one paddock suffices for all the others, the number of which depends entirely on the proposed strength of the depôt. To facilitate description we have supposed a depôt is being arranged for 1,000 horses; to accommodate this number four paddocks such as have just been described would be necessary.

These paddocks are placed side by side, each possessing a 20 foot gate made in two halves leading into the ring.

Within the area bounded by the exercising track is placed the enclosure for watering the horses. By pumps and in other ways water is brought into a sufficient number of troughs for the watering of 1,000 animals, and the total capacity of these must not be less than 3,000 gallons. They are best made of galvanized iron in portable lengths, and are arranged to communicate when fixed up, so that the pump delivers into one and fills the whole lot.

It is advantageous, and imperative if large numbers of horses are being imported weekly, to have a second watering enclosure, where the new arrivals may be dealt with until their freedom from disease is determined. This second watering place is indicated in Fig. 219. These watering enclosures are made of upright posts and wire, exactly as previously described, should be large enough to contain 250 horses at one time, and must afford 400 feet of standing room at the troughs.

Each watering enclosure has only one gate, and it opens into the ring.

Hitherto the various gates have been indicated but not described. The opening of each gate should not be less than 20 feet, and the structure may be made in two halves.

In Fig. 219 may be seen two roads running at the end of the series of paddocks marked 'way for forage carts.' The forage is conveyed in low horse trolleys by these roads, and through the back gates into the various enclosures, and the bales of hay and bags of oats are dropped at a convenient distance along the line of troughing, as soon as the business of exercise of each paddock has commenced.

There is only one gate for horses leading into or out of the *dépôt*, which may be seen indicated in Fig. 219. The object of this is that if a horse gets loose escape is practically impossible.

The scheme of construction is now completed so far as the exercise, watering, and feeding of the animals is concerned. For example, the 250 horses in one of the paddocks are gently directed through the open gate into the exercising ring by three mounted men, who follow them into the track and prevent any from breaking back. They carry whips for emergency, but are discouraged from using them, or from shouting or exciting the horses in any way. The animals have entered the ring at a tangent to it, and, therefore, unchecked; they are allowed to go round at their own pace, and soon trail out into a sort of procession. It is remarkable how quiet and orderly they are, even on the first occasion of being so manœuvred.

After they have been round their half-mile track a sufficient number of times, the gate of the watering enclosure is opened, and the leading horses are diverted through it, while the rest follow. The entrance to this water enclosure is made so that the horses can go straight in or out, without their pace being checked by indirectness or narrowness of the gate. From the moment the manœuvring is started the animals must be left alone to continue their way unchecked, until brought to a natural standstill at the watering troughs. Here they get their fill of water at a time when they may be permitted to drink any amount with impunity.

After watering, the whole of the horses are quietly returned to their enclosure, travelling in a reverse direction

to that in which they were exercised, by which means they enter the paddock in almost a straight line. The watering enclosure has, therefore, served as a reversing station.

As soon as the horses of the first paddock have returned to feed, those of the next are taken out to exercise and water, and so on until all are disposed of.

This procedure is carried out at daybreak, noon and afternoon, the rest of the day being free for receiving, issuing, and other routine work of the depôt. The track is watered if necessary after each exercise.

This is the automatic system by which large bodies of horses can be placed under absolutely hygienic conditions, and made 'fit' by a system of exercise which is under perfect control, while the sequence of exercise, watering, and feeding cannot be upset, and is largely carried out by the horses themselves.

Everything in war must be capable of expansion. A depôt intended to hold, say, 1,000 horses must be capable of dealing with 2,000, and our paddock of 250 now becomes one of 500. In such cases time is economized by having the watering paddock to communicate with a shunting paddock (see Fig. 219), so that after watering, the first 250 animals can be directed into the shunting paddock, where they wait until the next 250 are exercised and dealt with, then the whole 500 are returned in one body, and the next paddock started.

*The Crush.*—In all these operations there is not even a head-stall on the horses. Circumstances, however, may necessitate the catching up of, say, 250 horses in any paddock. The ordinary method is to herd them into a 'mob,' to the infinite risk of their limbs and feet, especially the coronets, and the destruction of the fence. Such a process would take hours in the case of partly-handled horses, and a very considerable time even with those that are 'broken in.'

The proper method of catching up these horses is by means of a 'crush.' The simplest conception of a crush is that it roughly resembles the funnel used for bottles.

There is a large opening at one end, and a narrow one at the other. The horses are directed into the wide opening, and are allowed to pass in single file into the narrow channel, where they are powerless to escape and head-collars are at once adjusted.

There are certain measurements of the 'crush' which are absolute, so that a detailed consideration of its structure is essential. Fig. 221 shows a plan of it. The arrows show the entrance into the funnel. The exit is the long, narrow gangway where the horses get caught up. The funnel end is only a convenient accessory into which the horses are coaxed to enter, and, by means of the

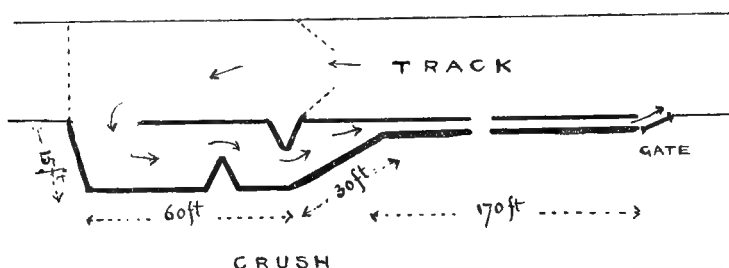

Fig. 221.—Diagram of a Plan of the 'Crush.' The dotted lines across the track indicate the closing of the gates, which imprison, say, 100 horses; these follow the direction of the arrows until they get in the narrow gangway. At the outlet of the gangway is a two-way gate, so that the horses can pass either to the right or left. The gangway is seen in section in Fig. 222, and in elevation in Figs. 223 and 224. The two-way gate is seen at Fig. 225.

V-shaped buttresses seen in the plan, they are unable to return. As a matter of fact, having entered, they wander forward, and soon find themselves in the gangway, with its two feet inside measurement.

The above principle of a crush is the same whether it is intended to hold ten or fifty horses at a time, the only difference being the question of length. In a large remount depôt a crush suitable for 100 horses would be a convenient size, and a crush to hold this number would be 170 feet long at its narrow part.

Fig. 222 shows a section of the gangway of the crush, which is five feet high, and two feet wide internal

measurement. Here will be seen a step running the whole length of the gangway on either side, on which the men stand to adjust the head-collars, or from which mallein

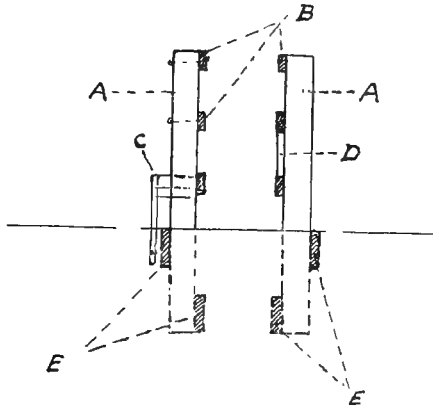

Fig. 222.—Section of gangway. AA, uprights, 5 feet in height and well let in the ground, with side pieces, EE, to render the structure firmer. B are three rails on each side of the gangway; on one side the interval between the bottom and middle rail is filled in, D, to prevent a horse kicking through. C is a step to enable the horses to be reached.

operations are performed. Figs. 223 and 224 show an elevation of the gangway.

At the end of the gangway—viz., at the outlet—is a

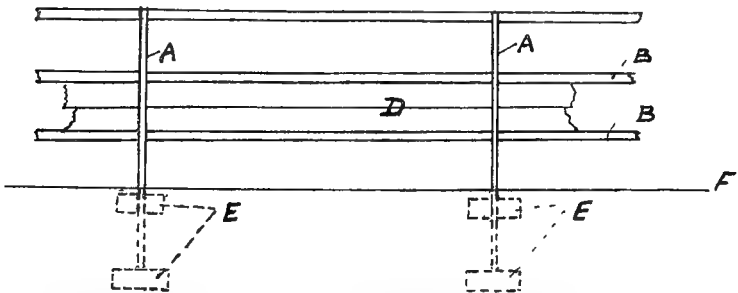

Fig. 223.—Elevation of gangway on the right side, showing the uprights, A, with side pieces, E; the three rails, B, and the space between the lower and middle rail filled in, D. F is the ground level.

swing gate (Fig. 225), useful in sorting horses. They may be passed either to the right or the left, depending upon the grouping of the examiner.

Only one point remains to be described, and that is how the 250 horses in the paddock are got to the funnel of the crush. It is done as follows:—The gate leading into the

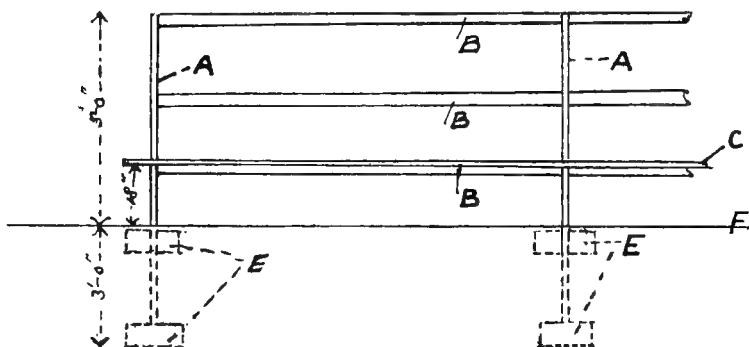

Fig. 224.—Elevation of gangway on the left side, showing uprights, A, with side pieces in the ground, E; the three rails, B, and the step, C. F is the ground level.

exercise track is opened, and the horses turned in the direction of the crush. At this point a pair of gates are swung across, and completely close the track. The herd of 100 or less, depending on the size of the crush, having

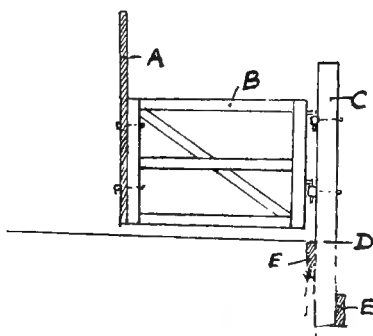

Fig. 225.—Two-way gate seen at the end of the gangway in Fig. 221; C, upright 5 feet in height; E E, side pieces for greater security; B is the gate with an upright, A, which prevents horses from rushing at the gate when escaping from the gangway.

reached these gates, another pair is closed behind them; see *x x*, Fig. 219 (Isometrical Plan), and Fig. 221. They are thus imprisoned in a section of the track, and the only

outlet is into the funnel end of the crush, which they readily try, and one horse is at once followed by another, until the gangway is full.

It takes longer to describe this process than it does to catch up the horses. Fifty men can put head-collars on a hundred horses in eight minutes with very little practice. In regular practice men can do it in half this time, including the leading out of the horses, and placing them in line for inspection.

With head-collars on, one hundred loose horses have been caught up in the crush in three minutes.

*Forges.*—In order to avoid the possibility of neglect of shoeing, the following arrangements are made. There are two enclosures side by side, both opening into the track, and between them are situated the forges, containing ten fires (see Fig. 219). The first of these enclosures is for the reception of the horses set aside for shoeing, and it may conveniently be made to contain, say, 200 horses. In this enclosure there is a crush identical in construction with the crush for general use which has been described. The object of this is to catch up successive lots of horses as they are required by the shoeing-smiths. The second enclosure, situated, as it has been explained, on the other side of the forge-building, is for the reception of the horses after they have been shod. Into this place they are accordingly let loose as the work of shoeing is completed. In both enclosures there are sufficient feeding-troughs, so that the animals can be fed either while they are waiting for shoeing or awaiting return to their paddock.

Horses that are waiting for shoeing or inspection after shoeing do not lose their exercise. Both these paddocks communicate with the track, and the animals can be exercised by themselves, watered, and fed in the ordinary way.

One advantage of the second paddock for the last shod horses of any particular day, is that there is a check on the amount of work done, as the number in the second paddock represents the day's work.

Further, if at any time it is desired to examine the quality of the work, the horses in the 'shod' enclosure can be let into the track, examined at the main crush, let loose as they are individually examined, and allowed to find their way around the track to the 'shod' enclosure, or placed at once in the paddock to which they belong.

*New Arrivals.*—We may here conveniently consider the method of dealing with new arrivals at the depôt. Let us suppose 500 horses have come to hand, weary, empty-looking, and 'tucked up.' There is a vacant paddock ready for their reception and their feed is already put out. They are examined one by one for contagious disease, any suspected are taken to a place of isolation, the sick to hospital, the rest, as they are examined, are let loose in the track. Leading out of the track is a second watering place reserved for new arrivals only; this is done with the object of limiting the possibilities of infectious disease. Into this watering place the horses are at once allowed to find their way, fill themselves with water, and permitted to lie and roll in the sand.

When the last of the new arrivals has been examined and let loose in the watering place, the whole lot can be allowed to find their way around the track, and into the paddock in which their feed has been made ready. The taking in of these horses has, it will be observed, occupied very little time, and no delay has occurred in giving them water and food.

For the first few days they are worried as little as possible, being merely observed as they do their allotted exercise in the track. Later, however, they will have sufficiently recovered to be tested with mallein; it is important that this should be determined as soon as convenient. Accordingly, a hundred of them are let out quietly into the track, and taken to the crush, where they are malleined while standing in the gangway; the whole hundred being done in a very short time, as the operator has only to walk from one to the other.

When the mallein results have been ascertained, restric-



tions as regards these 500 recent arrivals may now be relaxed; they can be put with another lot of improving horses, and watered in the general watering enclosure. Their feet, however, must first be attended to, and for this purpose they are transferred to the shoeing enclosure as early as convenient after malleining.

By the end of a week the recently joined 500 horses have been malleined, had their feet seen to or shod, and have had a week of work regulated according to their condition, and increasing with their improvement. They have recovered from their exhausted state, and have rested themselves to their hearts' content, lying at will day and night on the sandy soil of the enclosure. Under these conditions they have digested all food given to them, and have turned it into muscle.

It will now only be a matter of time before they become fit horses. But even if through necessity this preparation should unfortunately be interrupted, and these horses be required for issue prematurely, or to be passed on to another dépôt, they have benefited at least to the extent shown, while the risks of laminitis are greatly reduced.

*Exercise.*—The principle of the system described is based upon the consideration that horses with suitable arrangements can do much for themselves, which by custom is ordinarily done for them, and that in reality it becomes an absolute necessity, in dealing with large numbers, to let them at least water and exercise themselves. The system, however, goes further than this, as it provides a means whereby in a semi-automatic manner they get a regulated amount of work by which they are 'conditioned' for service.

If the animals are fat, care is taken that work is very gradually entered upon; in this way laminitis is avoided. Horses in a state of grossness flounder in their gait, and have no control over the muscles of the belly, which is thrown from side to side helplessly. Such animals are object lessons of the condition in which remounts should not be issued. As days go by and the work is increased, it is observable that the muscles of the belly are under

increasing control, and that the sprawling inco-ordinated movement is replaced by collected action. Thus from day to day, by gradually increasing work, they are being made fit to march if necessary 40 miles on the day they are issued.

While in the exercise track any restriction of the movements of horses, except to keep them quietly moving in the one direction, is greatly to be deprecated, and more especially the practice of restraining those in front. With a properly made track in sandy soil with high fences, there can be no danger whatever in letting them make their own pace, nor is there any likelihood of their going faster than is good for them. If taken in this way, with occasional quiet handling in the crush, they tend to get quieter and gentler every day, and so tame in disposition that in the paddocks they lie in groups, and will not get up unless made to do so. They rarely if ever kick one another, provided they get regular exercise, and that sufficient room is given them to feed.

In fact whilst still under full control they become used to being loose, which is no small consideration in respect of training for military purposes.

As sick, injured, or lame horses are seen to pass in the track, they are marked down and followed up on entry into the watering enclosure by special men on duty for this purpose, and after they have watered are quietly guided into a corner of the watering place, where they are caught up, taken outside the track, and tied up until the completion of work, when all are sent to the neighbouring Veterinary Hospital.

And here it is desirable to say that a Remount Dépôt and Veterinary Hospital are two distinct institutions, and on no account should ever be mixed up. Nothing that is not free from disease, lameness, or injury, should be found inside a Remount Dépôt, and in this way the place is prevented from becoming a centre of infection.

This completes the description of arrangements and methods adopted during war in order to get horses fit for

work. The construction of a depôt on these lines is a matter of skilled labour properly directed ; the responsible person must have a knowledge of the measurements required, materials suitable, be capable of directing construction, while in the choice of site he should see all the advantages and avoid the reverse.

The completion of the track, watering, and feeding arrangements, with the construction of two or three enclosures, are all that are essential for the reception of the first batch of remounts.

The subordinate staff should be civilians, three or four overseers, a good supply of shoeing-smiths, one or two permanent carpenters after the erection is complete, a leather worker, clerks, and local labour depending on the number of animals. No soldiers are needed for the care of the horses, local labour is in every way preferable.

Remount Depôts such as we have described should be situated (1) at the port of embarkation in the countries where the horses are purchased ; (2) at the port of landing in the seat of war ; and (3) at advanced bases as developments require.

*Veterinary Hospitals in War* are of two kinds, Field Hospitals which accompany the army and are essentially mobile, and Stationary Hospitals placed at convenient points on the Line of Communication and Base.

It is not intended that Field Hospitals should do more than deal with urgent cases, and those not likely to require prolonged treatment. Every useless mouth with the Field Army is a drain on the supply department, and the proper place for sick animals which offer no reasonable prospect of early recovery, is the Stationary Hospitals situated on the Line of Communication.

A Field Hospital relieves all regiments of their sick, so that the mobility of a regiment is not interfered with. Animals which are temporarily of no further use must go to hospital and be taken care of by the Veterinary Department. Further, it is the duty of the Field Hospital to collect and take along any horses abandoned by units, in

this way recovering many which may eventually take their place in the ranks, and thus save immense loss.

The actual amount of treatment which can be done while a force is moving is not much. Wounds can be attended to, and urgent cases treated, but when it is impossible to rest animals the chances of early recovery are not great.

An army is not marching every day, and it is during these intervals that active curative measures should be adopted. The cases should be grouped according to the nature of the disease, and the number of groups is likely to be that mentioned on p. 495. This grouping for systematic treatment is the essence of hospital methods; not only should the cases be grouped according to their nature, but if possible according to severity, so that the serious cases of any particular group are brought together, and are placed under better supervision than when scattered throughout the lines. The grouping systematizes work; for instance, the debility cases only require very little attention beyond rest, water, and food; the surgical cases will require the attention of the entire body of dressers, the lame cases the service of the farriers.

Every hospital must have its section for the reception of infectious cases or suspects; the bulk of these will be represented by mange, while a few may be waiting for the mallein test.

While on the question of the mallein test, it is perhaps well to add that reactors should not be destroyed if in moderately good condition. Such animals may have months of work left in them before becoming clinically affected, and if the campaign is a severe one, the probability is they will be dead from other causes before clinical signs show themselves.

All reactors should be branded, or marked for identification at the end of the campaign. Speaking generally, it may be stated that all attempts to get rid of glanders during active operations are costly and useless; what we can do is to keep it under control by the identification and destruction of those clinically affected.

A Field Hospital takes the earliest opportunity of sending back all horses useless to retain for treatment in the area of active operations, and these cases are sent to the Stationary Hospitals.

A Stationary Hospital is a much more highly organized institution than a Field Hospital. It has properly laid out lines, even, perhaps, temporary shelter for the sick, mangers, water troughs, baths for skin cases, baths for disinfecting purposes, an exercising track, tents for the men and equipment, and accommodation for stores. The sanitation of a standing camp, especially that used for hospitals, must receive urgent attention. One, two, or more changes of lines are imperative, depending on the weather, in order to prevent the ground getting seriously fouled. Dung must be collected and removed, standings scraped, latrines dug, and storm drainage provided for. The collection of a large number of sick in one place calls for the most urgent sanitary control.

A graveyard is one of the earliest matters to arrange for. It is no use discussing cremation unless the fuel exists. The death-rate may be one hundred a week, more or less, depending on circumstances. Long trenches should be dug by local labour, the animals disembowelled, stifles and elbows cut through so as to cause the limbs to drop, and the animals placed on their backs side by side, not a foot of space being wasted. Trench digging is laborious work, and may be unable to compete with the death-rate, let alone with the destructions, which may number a hundred or two at a time.

Under these circumstances a place must be selected as far from camp as possible, on elevated but flat ground, away from watercourses or collecting areas, and here the dead are laid on the surface after being disembowelled. They are placed side by side, and a good deep trench, six feet wide and not less than four feet deep, dug all round the place in the form of a circle or square, with a bridge of earth left affording access to this Golgotha.

The object of the trench is to collect the water deposited

on the graveyard area by rain, and cause it to percolate through the soil rather than run over the surface. Later on, as labour becomes available, the carcasses may be buried, or, in hot countries if they have shrunk up and dried, they may then be easily burned, the tissues supplying their own fuel once the water is lost by drying.\*

The collection of the dead may, under certain circumstances, have to be undertaken. If recently dead they can, with considerable labour, be hauled away, for no other form of transport is likely to be available. If decomposed, the tissues will not stand being dragged on, but the carcass may be placed on a raw hide to which the traces are attached, and so taken to some specially selected collecting area.

It is useless a Stationary Hospital being established away from a source of water-supply, for the time occupied in watering some hundreds of cases prevents the ordinary work of the hospital being conducted. If a river is used for watering, the part selected is below that from which the water for the troops is drawn. If the banks of the river are steep and deep, the debility cases will not have strength to pull themselves up, so an easy road down must be made. If water can be pumped up from the river to troughs on its bank it is an immense advantage, and, under any circumstances, whether the supply be from river or pond, watering should take place on the bank and not in the water, which, otherwise is kept in a constant condition of muddiness through being churned up by the horses' feet. The watering can be carried out by means of nose-bags if there is no pump or trough.

The proximity of water is also essential for the washing of wounds and of skin cases—in fact, unless an ample supply exists the place is unsuitable for a hospital.

The splashing of mud during washing wounds of the

\* I am indebted to Colonel Flintoff, D.S.O., late A.V.D., for this suggestion, imported from South America, where dried portions of animal remains are in certain places used as fuel. During the war in South Africa, he burned in this way the dried remains of hundreds of horses.

limb, may be controlled by putting down a waggon cover or sail on which the horses stand to be dressed. A similar contrivance may be arranged for the dressing of skin cases where water dressings, such as izal, are employed; and to prevent waste of these, especially when running short of material, a depression in the ground, covered by the sail, acts as a well into which the dressing runs as it drips off the horses, and after straining through a sack may be recovered for subsequent dressings.

Beds for the sick may be made by digging up the ground to the depth of a foot. A circular bed is the best, with a peg in the centre well sunk out of harm's way.

The most important general equipment for a hospital consists of nose-bags, head-collars, ropes, and picket lines. Without these it is impossible to deal with the sick as they pour into hospital. They should be as much part of the hospital equipment as the medicine chests. To have to admit one, two, or three hundred sick without a head-rope or picket line is a serious matter.

There is no necessity to describe the group system of arranging the cases, as it has already been mentioned in dealing with a Field Hospital, but without it the whole thing is chaos.

If a campaign lasts long enough, enclosures of plain (not barbed) wire can be made, with mangering, where the horses may be turned loose. These enclosures should never have more than 200 animals in them. A preferable size is fifty, as the supervision is better.

If in a bush country, these enclosures may be protected from the cold of winter by having bushes laced through the wire of the enclosure. Some useful hints for winter protection of sick horses on a campaign, may be obtained from the figures on p. 856.

We cannot go into the details of hospital organization or routine, but the principle to bear in mind is this: the hospital should never start from its destination without the needful equipment. With 500 head-collars, 1,000 head-ropes, hundreds of nose-bags, hundreds of fathoms of

two inch rope, and scores of pegs of suitable length, with means for driving them in, a place may be made for the reception of some hundreds of sick in a few hours. The grouping of the cases must follow. The first thing is to relieve regiments of their sick, and this cannot possibly be done without the above.

It must not be assumed that the sole equipment required by a hospital is that just mentioned. Why these are specially specified is that without them a hospital had far better not start, while with them something can be done.

The number of Stationary Hospitals on the line of communications depends on the length of the latter and on the number of lines. No rule can be laid down, convenience of feeding, proximity of water-supply, and suitable facilities for protection are the factors which govern this. There is one rule, however, that must always be observed, and that is to regularly work down the line all cases that are likely to take some time to cure. The nearer a useless mouth is brought to the base the easier and cheaper it is to feed it. The hospital on the line which is the nearest to the army should always be ready to take in the whole of the sick of the Field Hospitals; at very short notice an army may move, and the Field Hospitals must at once get rid of their cases, or they become hopelessly congested; these are received by the nearest Stationary Hospital on the line.

As we have previously stated it is impossible in the space at our disposal to do more than give an outline of the Hospital organization in War. The supply of medicine, dressings, and surgical means is quite a distinct branch, and requires its own personnel and organization.

It is desirable to note that a Stationary Veterinary Hospital will always be placed on the line where a Remount Depôt exists, so as to receive its cases as well as those of the Field Army. Into the Remount Depôt are returned all horses as they recover; the Remount Depôt, conducted on the lines mentioned in the section dealing with their organization, being charged with the duty of getting these animals fit before they are again issued to regiments



*Marking Army Horses.*—From what has been said it requires no effort of imagination to understand how impossible it becomes to identify horses after they have once left their regiments, and been filtering up and down the line, passing from regiments to hospitals, from hospitals to remount depôts, and so back to regiments. Every army animal bears a number branded on its foot; this brand may last three months or longer, depending upon its position on the wall; month by month it grows more indistinct until finally it is impossible to recognise, and equally impossible to replace. On service there is often no fuel, more frequently no branding irons, and when both exist no time even if the number were known. It takes a long time to brand four or five figures on the feet of even fifty horses, and in a large hospital or remount depôt would require a special staff for this work alone.

The army number of every horse and mule can be put on for once and all at the time of purchase, and rendered permanent for life, by the simple process of tattooing it on the gum above the upper incisor teeth. In fact, on this place can be placed all that is necessary to know of any army animal, viz., its number, age at purchase, and year of purchase, for example:—

17694—4—01

gives us at once the army number of the horse, his age, and his length of service.

During time of war, when horses are being purchased in half a dozen different countries, a prefix letter previously agreed upon, would indicate whether the animal came from Russia or Hungary, America or Australia, and will also determine the name of the purchaser.

An expert hand can tattoo the figures in a few minutes, the gum being rendered insensitive by tincture of aconite; or they can be made by means of an instrument.

Finally, by the above system not only is the identity of a horse never lost, but in the event of it being stolen no question of ownership can arise. In the case of private animals the name of the owner can be put on.

## CHAPTER XVII

### CLIMATE

WHEN we speak of the climate of a place we refer to conditions of temperature, to the relative dryness or dampness of the air, to the presence or absence of winds, to rain, its absence or excess, and to altitude. The whole question of climate depends upon these factors of which, perhaps, temperature is the most important.

Though extremes of temperature may be a cause of death, and certain conditions of wind and rain predispose to disease, yet the science of bacteriology has largely exposed the fallacy which underlies the argument of blaming climate as a cause of unhealthiness; the pestilential vapours and miasma, so prominent a feature in the pathology of a few years ago, have vanished under the exactitude of experimental inquiry. What was originally considered a deadly vapour now frequently turns out to be a deadly insect.

The fact is that though climates are spoken of as healthy and unhealthy, we know very little of the real influence on health of climate as above defined; exact observation shows that what used to be attributed to climate may now turn out to be a micro-organism. Further, climate has been blamed when the fault lay with insanitary surroundings, and the neglect of sanitary precautions; especially has this been the case in hot countries.

A country may be unhealthy for one class of animal and not for others, which proves that it is not a question of climate; no better example could be quoted than South

Africa, which is a health resort for man but the home of pestilence for animals. It is not the climate which must be blamed for this latter, but largely the existence of insect life charged with pathogenic germs.\*

It is, however, undoubted that heat, cold, rain, and wind may act as predisposing causes of disease, and we may briefly glance at these as factors, and consider how they operate.

In hot climates there is less tissue change occurring, and in consequence less urea and carbonic acid are excreted, while there is a freer action of the skin and less urine. The heated air owing to expansion contains less oxygen, and the number of respirations is increased in order to compensate for this. The extremely active condition of the skin is part of the cooling mechanism, and prevents the blood rising to the temperature of the air; the effect of long-continued heat, especially in the absence of air movement, becomes very trying, and with man heat-apoplexy may under these conditions occur. There is nothing corresponding to this in animals, excepting when they are performing labour: severe exertion plus a high external temperature with especially no movement of the air, may then easily cause death. This is probably brought about by want of proper oxygenation of the blood in an atmosphere largely expanded by heat. During hot weather the body temperature rises considerably during work, but falls with cessation of labour.

In the absence of work the direct rays of the sun have no action on the central nervous system of any equine or ruminant; but in animals new to hot countries the body temperature may rise, and a condition of fever be produced from standing exposed to the sun. The temperature will also rise if acclimatized animals are left standing in a hot sun, but with them it does not appear to be pathological.

Animals, especially until acclimatized, feel the sun and seek every opportunity for obtaining shade; but that in

\* In this chapter the term insect is used in its convenient and not necessarily zoological sense.

itself counts for little. All animal life in the hot weather, for instance, in India, does the same during the heat of the day; even the crow of the country will sit on the ground under a tree with the mouth wide open gasping for breath, and he certainly should be fully acclimatized.

In seasoned animals a dry heat is borne with comparative indifference; in the case of horses their coats may be burned and their muzzles sore from the rays of the sun, but there is no such thing as sunstroke and no illness due to the sun's rays, though they may be exposed to them the whole time the sun is above the horizon. But when the air becomes saturated with moisture and the heat is a damp one, then the loss of heat by evaporation from the skin is interfered with, and the effects on animals are enervating and depressing.

The lessened evaporation under these circumstances is due to the humidity of the air which checks evaporation from the skin and lungs, for the air being nearly or wholly saturated has but little drying power. Hence one of the chief means of keeping the blood at its proper temperature is lost, while the distress and enervation which accompanies a continuous vapour bath is evident.

One of the most remarkable physiological features is the perfect manner in which the body adapts itself to a rise and fall of the surrounding temperature. Adaptation to a gradual rise or gradual fall one can understand, but the mechanism which admits of a variation of forty degrees of the thermometer in a few hours is a very perfect one.

The effect of cold is to increase tissue metabolism, and in order to provide for this a larger amount of food, especially carbonaceous, must be taken. The contraction of the atmosphere enables more oxygen to be taken in at each inspiration, so that the hurried respirations of high temperatures are wanting, while the contracted state of the capillaries of the skin reduces considerably the loss of heat from this surface, and in consequence of there being less evaporation a larger bulk of urine is secreted.

Low temperatures are perfectly withstood provided there

is a sufficient food-supply, but under the condition of starvation cold readily kills. Extremely low temperatures are tolerated provided the air is still, while a moderate degree of cold is intensely felt if a wind is blowing, for a dry wind causes a loss of heat to the body.

The effect of a reduction in atmospheric pressure, such as is obtained at high altitudes, causes at first a difficulty in breathing, as owing to the expansion of the air insufficient oxygen enters the blood; but this after a short residence passes away, though we are told\* that animals working on the Cordillera of Peru suffer from a disease known as *veda*, which shows itself by great difficulty in breathing and muscular tremors. Animals so affected die if not rested.

At considerable elevations there is generally a more active movement of the atmosphere, and the air is drier. The air on the Cordillera is so remarkably dry that a dead animal becomes mummified in the course of a few days with, it is said, no evidence of decomposition.

The temperature at high altitudes is liable to great daily variations, the days may be hot, while the rapid radiation after the sun sets produces considerable cooling and lowering of air temperature.

At moderate altitudes, say up to 4,000 feet, there is no evidence whatever among animals that they experience the slightest difficulty in breathing, and certainly none in work. So adjustable is the organism that neither a reduction nor an increase in atmospheric pressure within moderation produce harmful effects. Animals continue to work in deep mines for years and never come to the surface; the fact of their working for years shows that they must enjoy a large measure of health; their breathing and circulation may be slower, but there are no other observable conditions the result of the increase in pressure. Sudden reductions in body pressure are very harmful, they are seen in divers and men working in caissons; sudden reductions in

\* 'Influence of Atmospheric Pressure and Altitude.' The late Dr. Fleming, F.R.C.V.S., *Veterinarian*, 1868.

pressure may lead to hæmorrhages, especially in tissues like the membrane of the cord, followed by immediate paralysis.

Winds are infinitely more likely to produce disease than cold without wind, and the cause of this has been previously touched on. Of the various factors in climate, viz., heat, cold, reduction or increase in pressure, and rain, nothing in our opinion can approach cold wind as a pathological factor.

In cold weather it robs the body of heat, in warm weather or over a sweating surface it does the same thing, in both cases it may produce that common but remarkable pathological condition known as 'chill,' though it is far more likely to produce this when blowing over a hot wet surface than when playing on a cool dry one.

In the whole range of climatic causes we are convinced that a cold wind stands pre-eminent; through the influence of chill it is responsible for the production of inflammatory chest diseases in cold climates, and to congestion of the abdominal viscera in hot. There are even forms of paralysis in tropical countries like India attributed to wind; and in horses the affection is popularly known as 'wind-stroke.' Its pathology is quite unknown, and the wind may have no more influence in its production than the moon has in the production of ophthalmia.

Animals at liberty instinctively turn their backs to the wind especially when this is associated with rain. During heavy rain and wind the back is arched, the legs drawn together, the tail pressed into the quarters, the head drawn back, and the neck arched on its upper surface, as if the muscles were unable to resist the elastic recoil of the ligamentum nuchæ.

The influence of rain in the production of disease is mainly indirect. Two pests like anthrax and South African Horse Sickness are practically only seen during the rainy season, but the influence of the rain in the latter disease is to rouse into activity the intermediate host. Insect life during the rains under the influence of heat and moisture,

becomes extraordinarily active both in tropical and subtropical regions. It is inconceivable the myriads of insects and scores of varieties which come from the ground after the first rain ; the extraordinary thing is they come out in the adult form, active, full of life and energy, just as if they had been waiting under cover for months for the rain to appear. Among the insects which put in an appearance is the intermediate host of Horse Sickness ; it is this insect and not the rain which produces the disease.

In Indian anthrax the rain mainly acts by distributing the spores over the soil, while the high temperature which exists at this time of the year facilitates the growth of the organism.

Diseases like rheumatism are without doubt more frequent during wet or damp weather, but rheumatic affections of animals are rare.

If we regard climate as made up of heat, cold, rain, wind, and altitude, an excess of any of these may kill or greatly influence the body, but there is nothing in them specifically unhealthy, so that unhealthy climates, so called, are due to other causes, some of which we have outlined above.

If now we come to consider *Acclimatization* we are met by still more difficulties ; very little exact knowledge exists as to the changes occurring in the body, which render an animal capable of living in a totally different climate to the one in which it has been born and brought up.

In matters of altitude there is no doubt the system rapidly adapts itself to the reduction in pressure ; but altitude in the case of the herbivora means a change in forage plants, and what may be attributed to reduced pressure is probably nothing more than the stomach and intestinal canal adjusting itself to the change in food. The danger incurred of passing from highlands to lowlands is mainly dietary, while in tropical and subtropical countries there is in addition the question of passing to an area of increased activity in insect life, for this latter is to an extent controlled by moderate altitude, and practically completely held in check by considerable altitude.

We have seen in Horse Sickness how valuable altitude is, even a relatively small rise may be sufficient to secure comparative immunity.

In dealing with the question of heat it was pointed out how very rapidly the body by its mechanisms adjusts itself to a rise in external temperature, and though animals from cold countries feel the heat on introduction to hot climates, they very soon, in the course of a few months, become perfectly adapted to their new surroundings. If the transit is from cold northern to southern latitudes, the abrupt transition from winter to summer is felt in the case of horses, mainly, perhaps, owing to the presence of the heavy winter coat. It would appear that it frequently takes from one to two years before the change in the coat is properly established, and there are many observers who regard this, and with a good show of reason, as an index to acclimatization. It takes the Australian horse at least a year to become acclimatized in South Africa, though it involves no transition from one season to another. It takes the same horse two years to be acclimatized to India, where a change in season is involved, and far greater heat experienced. In both these cases the change in food must also be taken into account, though this is much more easily adjusted than the other surroundings.

During wet and hot seasons in tropical and subtropical countries, horses are certainly not at their best, and this is probably explained as the result of the languor which heat and moisture combined are capable of causing.

Wounds are liable to take on an unhealthy appearance, and the specific indolent ulcer of India, known as Bursattee, is essentially a wet-weather product, though this and allied sores may yet be shown to be parasitic.

There is still a more complex aspect to acclimatization. Animals may inherit an immunity to indigenous diseases from which the the newcomer suffers. For example, it is practically impossible to produce Biliary Fever in the native horse of the Transvaal, they are protected by a natural immunity while a foreign horse can be infected



with the greatest certainty. Algerian sheep have a natural immunity against Anthrax. Some Indian cattle are highly resistant though not completely immune to Rinderpest, and only exceptionally die from 'Surra.' The cattle of the East Coast of Africa are immune to tropical pyroplasmosis. Wild cattle in the Fly Belts of Africa, also the Masai donkeys, are immune to *Tsetse*. Texas cattle, and other cattle reared in an infected country, have a high degree of resistance to Red Water. Persian sheep show considerable immunity to Heart Water, while it is well known that the native inhabitants of malarious districts have a natural immunity to Fever, though, as in Red Water of animals, they are capable through the intermediate host of infecting newcomers.

Probably this aspect of acclimatization is by far the most important, as it is the indigenous diseases rather than heat, cold, rain, wind, altitude, and change in diet, which so enormously influence new arrivals in a country.

CHAPTER XVIII  
STATISTICAL INQUIRY

A LARGE and interesting field is open to the veterinary statistician, for with the exception of the returns of Contagious Diseases furnished by the Board of Agriculture, and the returns furnished by the Veterinary Department of the Army, but little has been done in the matter.

We have very little idea what the loss of horses is in civil life, either from old age, accident, or disease. We do not even know how many horses there are in Britain, or the equine population of any of our large towns! The value of such information would be very great, especially to the political economist and hygienist.

We require information respecting the distribution of disease in all classes of animals, and its mortality; the influence of season, sex, age, work, and management on the production of disease. We ought to know for what period horses may be reasonably expected to last in our big cities, employed in the different capacities assigned to them; the proportion of sound and unsound horses of different breeds, and the common causes of unsoundness in each.

Many persons affect to ignore statistics, and it is usual to say that figures may be made to prove anything. This is not correct; statistics have their value when the data are reliable, and the matter carefully handled with the object of eliminating error. The causes which may vitiate statistics are an incorrect, incomplete, and insufficient number of facts, and illogical grouping.

*An accurate collection of facts* forms the foundation of statistical inquiry. The importance of a correct diagnosis is here exemplified; there must be no doubt whatever as to the nature of the cases we are examining; if there is a doubt they must be rejected from the inquiry. Let us take one or two examples.

Suppose we wish to ascertain the number of horses which have suffered from sprains of ligaments or tendons during the year; we must take care that every unit we accept has undoubtedly suffered from sprain, and that the word 'sprain' has not been used in the record of cases to cover any lameness which could not be diagnosed. In other words, unless we can see or feel a sprain, we cannot be warranted in recording the case as such. If we use the term 'sprain' to cover the many forms of obscure lameness to which the horse is liable, it is evident that the statistical results obtained from such data are worthless. Where it is difficult to make a diagnosis the case must be shown by itself as 'obscure,' and only when the nature of the lameness is beyond all doubt should it receive a name.

We all know how many cases of lameness there are the nature of which is beyond all doubt,\* and it only shows how careful we should be in assigning a cause to lameness, unless, from peculiarity of action, changes in the shape of a part, or history of the case, there can be no reasonable doubt as to the nature of the disease.

One more example, to show the necessity of accurately collecting facts. We will suppose a horse is seized with colic, and suffers pain for several hours; this ultimately subsides, is succeeded by obstinate constipation lasting a few days, and ends in death from impaction and enteritis. At the post-mortem examination the cause of the trouble is found to be an intestinal calculus. There can be no doubt in a logical mind in which class such a case should be included; yet, according to a system we have known

\* Our opinion is that 50 per cent. of lame cases are obscure during the earlier stages of lameness, and many remain permanently so.

pursued, the case would first be admitted for the attack of colic and discharged relieved, re-admitted for constipation and discharged relieved, and finally admitted for intestinal calculus or enteritis and discharged 'died.' Therefore, during one illness, this horse swelled the list of admissions of two diseases which were only present in his particular case as symptoms, and he would accordingly vitiate the returns connected with the admissions and recoveries of these diseases. If this method of collecting data be carried out in a number of cases, it is easily seen how devoid of value such statistical results must be.

Every unit forming part of a series representing any disease, must without doubt belong to this disease, and to no other. If there is a doubt about it, omit the unit entirely, and account for it under the heading of 'obscure.' It is not the compiler of statistics who is answerable for the correctness of the units, the responsibility rests with those who furnish them.

*Group Building.*—The second point to attend to is the grouping or arranging of the figures, so as to analyze what they really represent. This group building, as Parkes said, seems simple; but, in reality, 'to properly group complex facts so as to analyze them, and to bring out all the possible inferences, can only be done by the most subtle and logical mind.'

Let us suppose that we have collected the record of 1,200 cases of pneumonia, and wish to learn from them the lessons they are certainly capable of teaching if we only know how to extract them. We can ascertain the various supposed causes, the mean duration of the affection, the effects of certain methods of treatment, the mortality, etc. The portion of the inquiry of most interest to the hygienist are the causes in operation and the mortality, and one would probably find that some such plan as the following would be the most suitable method of work—viz., to study the influence of season, age, sanitation, work, and the effects of strangles and influenza. These would be termed the dividing characters.

The influence of season would be ascertained by arranging the cases in the four quarters of the year in which they occurred. The influence of age would be obtained by arranging the cases according to their ages, and the other dividing characters would be examined in like manner.

In grouping results, it is very difficult to arrange the dividing characters so that all the cases selected will fit into them, and that one case will fall only to one group and to no other. A disregard of this latter rule—viz., that no case can appear in two groups at the same time—will render all groupings worthless.

In observations extending over a series of years, we have an opportunity afforded of ascertaining whether there is an improvement in the general health, and a decrease in the mortality. By a careful consideration of facts we can be led to determine the causes acting beneficially or otherwise in this direction.

*A sufficient number of facts* is absolutely essential if any correct deductions are to be drawn. Conclusions based on a small number of observations are insufficient to establish a fact, for the reason that it can be mathematically demonstrated that where the number of units is small, the chances that the same result will be obtained again with a similar number of cases is highly improbable; whereas, when deductions are drawn from a large number of units, the chances of error are less, and the probability is that with a similar number like results will be obtained on another occasion. The reason why this is so can be readily appreciated; errors in a few numbers alter considerably the value of the results, whereas errors acting through a large series of numbers tend to neutralize each other, owing to some being greater and others less than the real value.

The larger the number of observations the greater the accuracy, but the error only diminishes as the square root of the number of observations, so that twice the accuracy is not obtained by doubling the number of observations; it requires four times the number of facts to effect this.

When we have a large number of units collected which

have been operating through a length of time, representing such events as ages, deaths, castings, destructions, etc., we can ascertain, by means of an average, the mean value of these collected figures. The average will not necessarily give the value of any one unit of the group, for it is almost sure to be either above or below the actual value of a single unit; but it will give us a general value of the whole series. For example, a business firm has 365 horses of an average age of 8 years. It by no means follows that all or any of the horses are 8 years old. Many will be above or below—in fact, the ages of the horses may vary from 5 years to 20 years old. The quantities either above or below the average are termed the 'extreme values.' As Dr. Parkes expressed it, extreme values are the two ends of the scale of which the average is the middle.

Averages must not be struck from a series of percentages, by adding them up and dividing by the number of series. For instance :

250 admissions with 10 deaths gives a mortality of 4·0 per cent.  
 120 admissions with 9 deaths gives a mortality of 7·50 per cent.  
 1050 admissions with 35 deaths gives a mortality of 3·33 per. cent.

If the percentage mortality be added together and divided by three, the result is 4·94, which is not the true percentage.

The correct method is that 1,420 cases furnished 54 deaths, and the real percentage is, therefore, 3·8, and not 4·94, as calculated above.

One more example may be useful :

MONTHLY ADMISSIONS AND MORTALITY FOR DISEASES OF THE DIGESTIVE SYSTEM.

	Jan.	Feb.	March.	April.	May.	June.	July.	Aug.	Sept.	Oct.	Nov.	Dec.
Strength	464	534	527	1069	725	549	531	540	559	594	549	490
Admissions	31	94	20	1	3	0	0	1	6	18	8	4
Per cent.	6·68	17·60	3·79	·09	·41	—	—	·18	1·07	3·03	1·45	·80
Mortality	5	8	2	0	1	—	—	—	—	2	1	1
Per cent.	1·07	1·49	·37	—	·13	—	—	—	—	·36	·18	·20

The percentage of admission and mortality for the year is not obtained by adding the monthly percentages together and dividing by 12, but by ascertaining the average strength, and by rule of three calculating what percentage the total admissions and deaths bear to this. In the example given, the average strength for the twelve months was 594.25, and the total admissions 186; therefore  $186 \times 100 \div 594.25 = 31.29$  per cent. admissions per annum, and  $20 \times 100 \div 594.25 = 3.36$  per cent. deaths per annum.

In expressing statistical results, some constant means of comparison must be adopted, such as per cent., per 1,000, or per 10,000, etc. The most common standard used is per cent.

To ascertain the percentage is a rule-of-three sum. Suppose, for instance, that in a strength of 3,978 horses 428 cases of strangles occurred causing 12 deaths, we can ascertain :

- (1) What proportion of the horses were attacked.
- (2) Of those attacked, what was the mortality.
- (3) Of those attacked, what were the recoveries.
- (4) The mortality on the total strength.

One or two examples of the working will suffice for the others.

In 428 cases of strangles there are 12 deaths. What is the mortality per cent. of those attacked ?

$$\frac{12 \times 100}{428} = 2.803 \text{ per cent.}$$

In 428 cases of the disease there are 12 deaths. What proportion per cent. recovered ?

$$\frac{416 \times 100}{428} = 97.196 \text{ per cent.}$$

The value of statistical inquiry in questions relating to health, disease, mortality, casting, etc., is obvious. We should know the proportion of horses which are constantly sick, the average length of time under treatment, and the general inefficiency which this represents.

Here are a few examples of the method of obtaining this information :

The *Admission Rate* for sickness is calculated by adding together the total number of admissions for each month, and then by rule of three ascertaining what percentage of the average annual strength this represents. For example :

The admissions for twelve months are 447 ;  
 The average strength for the year is 597·25 ;  
 Therefore  $447 \times 100 \div 597 \cdot 25 = 74 \cdot 84$ ,

which is the percentage of sick during the year. To state the fact in another way, out of every 100 horses, 74·84 for one reason or another, had been brought under treatment during the year.

The mortality for the year is ascertained in the same way :

The mortality being 20,  
 The average strength 597·25,  
 $20 \times 100 \div 597 \cdot 25 = 3 \cdot 34$  per cent. of deaths per annum.

The *Average Daily Number Constantly Sick in Hospital*—viz., the *Sick Population*—is ascertained by adding up the number of days each case was in hospital, including the day of admission and discharge, and dividing the total by 365, or 366 for leap year. All cases remaining in hospital from the previous year must be included.

Or it may be obtained, though with less exactitude, by taking the numbers remaining under treatment at the end of each week or month, and dividing by the number of weeks or months.

For example, the number remaining under treatment at the end of each month for twelve months equals 478 :

$478 \div 12 = 39 \cdot 83$  constantly sick ;  
 The average strength of animals for the year is 597·25 ;  
 Therefore  $39 \cdot 83 \times 100 \div 597 \cdot 25 = 6 \cdot 66$  per cent. constantly sick.

To find the *Average Duration of each Case of Sickness*—viz., the average number of days each case was under treatment—multiply the sick population by the number of days in the year, and divide by the number of admissions :



Sick population = 39·83.  
 Number of days = 366.  
 Number of admissions = 447.  
 $39\cdot83 \times 366 \div 447 = 32\cdot61$  days,

which is the average duration of each case, and represents the number of days' service lost by each of the sick.

*Average Inefficiency per Head.*—Though, in the case we have supposed, 74·84 horses out of every hundred were sick during the year, and the average number of days each was under treatment was over 32, yet it is interesting to ascertain what the average inefficiency for each animal amounted to in consequence. The rule is to multiply the sick population by the number of days in the year under review, and divide by the average strength :

Sick population = 39·83 ;  
 Number of days = 366 ;  
 Average strength = 597·25 ;  
 $39\cdot83 \times 366 = 14,577\cdot78 \div 597\cdot25 = 24\cdot4$  days—

viz., the amount of sickness for the year was such as to be equivalent to the loss of 24·4 days service for each horse in the stud. With the above data, it is a simple matter to ascertain the money loss in consequence of sickness, when the cost of keep and attendance is known.

*Expression of Statistical Results.*—Statistical results may be expressed in a graphic manner by intersecting horizontal and vertical lines. The horizontal lines are known as the axis of the abscissæ, the vertical as the axis of the ordinates. For example, in Fig. 188, p. 557, the axis of the abscissæ represent the number of events, while the axis of the ordinates represent a certain time ; when these two quantities are connected by lines with others of the series, a curve is obtained which forms a graphic representation of their relationship, and appeals more readily to the mind than rows of figures.

A system of columns may also be employed, of which Fig. 218, p. 963, is an example.

The most important points which require to be dealt with in veterinary statistics are :

(1) The animal population, and its rate of increase.

(2) Regarding the increase, we should know the proportion of male and female births; of premature births and abortions; also the proportion of animals which may prove barren, and the deaths occurring amongst young animals during their first year of life.

(3) The amount of sickness and mortality among horses in military and civil employment, grouped according to disease, season, age, sex, occupation, and geographical distribution.

(4) The mean duration of life among horses, grouped according to occupation.

(5) The principal causes of unsoundness among horses grouped according to breed and occupation, showing the mean age at which permanent unsoundness becomes developed.

(6) The mean period for which useful work may be expected from a horse, grouped according to occupation.

We may say at once that we have very little information on any of these points; taking the first, *we have no knowledge of the total number of horses in the United Kingdom*; the returns furnished by the Board of Agriculture only deal with horses kept for agricultural purposes, including mares kept for breeding and unbroken horses. This state of affairs is permitted to exist in a country which prides itself on being the first horse country in the world!

The following table, compiled from the latest available returns, gives the animal population of Great Britain and the Colonies:—

ANIMAL POPULATION.\*

Countries.	Horses.	Cattle.	Sheep.	Pigs.
†United Kingdom	2,101,833	11,575,965	29,105,074	4,192,092
Australia ... ..	1,625,741	8,459,036	72,322,918	958,268
Canada ... ..	800,831	2,984,838	1,665,295	2,082,545
Cape of Good Hope	387,824	1,077,044	12,639,992	245,947
Natal ... ..	66,695	519,689	562,422	55,639
British India ...	1,309,189	‡49,306,962	17,736,199	—
New Zealand ...	286,955	1,460,663	19,002,049	193,740

\* Agricultural Statistics, Board of Agriculture, 1903 and 1904.

† Returns for the year 1904.

‡ Exclusive of Bengal.

*Births.*—The proportion of male and female births we have ascertained for the thoroughbred horse to be as follows.\* 49·7 per cent. of the total births are colts, and 50·3 are fillies. For every 1,000 fillies there are 989·06 colts born. We do not know what the proportions are among other animals.

Of every 100 mares (thoroughbred) put to the horse, 25·5 per cent. prove barren; the returns do not show whether the mares were permanently barren, or whether they proved fruitful in after years, or in alternate years; of every 100 mares in foal, 4·04 abort.

*The mortality* among brood mares is 4·27 per cent. per annum; of the ages at death we have no data to hand.

The mortality among army horses at home, including destructions, varies from  $1\frac{1}{2}$  per cent. to  $2\frac{1}{2}$  per cent. per annum.

*The amount of sickness* among animals in civil life we have no idea of; in the army alone, and a few public companies which keep returns, can we obtain the required information.

Between 60 per cent. and 70 per cent. on the total strength of army horses are admitted to treatment during a year; many of the diseases are wounds and contusions, which in civil life would not be allowed to interfere with the animal's work; the number of days' service lost yearly to the State by each horse sick is about twenty.

Where care is exercised, and an animal's work only stopped when really necessary, it will generally be found among any large body of horses, that from 4 per cent. to 5 per cent. are constantly sick or lame. This only applies at home, it is higher in India and especially in South Africa.

*The normal duration of life*, for obvious reasons is very difficult to fix. We considered the best plan of obtaining it would be to ascertain the age at death of all animals which

\* Obtained from the figures given in the 'Stud Book,' but not including those published within the last eighteen years.

during their life had been well cared for and not over-worked; for this reason the thoroughbred stallion was selected, and the age obtained from the 'Stud Book.' The mean age at death from natural causes was 17·34 years. The mean age of those destroyed (old age, broken legs, etc.) was 22·84 years.

The probable duration of life is about 18·29 years. In the figures examined, the extremes were 5 years and 33 years.

From the elaborate article by Dr. Balfour,\* which we have previously had occasion to refer to, we can obtain much information respecting the age at death of working horses (the observations are from the records of the French Cavalry). The highest mortality occurs at 4 years of age, and decreases till 11, when it reaches the minimum. The chief deaths occur at 4, 5, and 6 years of age. More mares die than horses—the excess is equal to  $4\frac{1}{4}$  per 1,000; on the other hand, 11 per 1,000 more horses are cast than mares. The total loss of geldings over mares is  $6\frac{3}{4}$  per 1,000 greater.

*Castings.*—The chief cause of casting is for worn-out legs 2·8 per cent.; incurable lameness 1 per cent.; broken wind 5 per cent.; old age, 13·4 per cent.

*Influence of Season.*—More horses are sick in April, May, and June, and fewer in October, November, and December. Diseases of the lungs are most frequent during the second quarter of the year. Strangles is most frequent in the second quarter, and least in the fourth. Diseases of the bowels are more frequent during the third quarter, and least during the first quarter of the year.

It must be remembered that these results are from French Army horses. Climate, breed, stable management, and many other points may cause them to differ from what occurs in the United Kingdom.

*The period for which horses will stand work* in civil life varies with its nature. Cab-horses work for about 2 or 3

\* 'Vital Statistics of Cavalry Horses,' *Journal of the Statistical Society*, June, 1880.

years. From information kindly furnished me by some of the public passenger carrying companies, we learn that the horses last about 6 to  $6\frac{1}{2}$  years. The death-rate is between 4 per cent. and 5 per cent. per annum. These companies only purchase between the ages of 5 and 7 years.

The army horse works for about 8 or 9 years, but as he is purchased between 3 and 4 years of age, we get but little more work out of him than public companies get out of their horses, and have to give in return for it about 2 years' keep, and run the risks incidental to youth. Before army animals arrive at the mature age of those purchased by big companies, they cost in keep what would buy another horse.

Some statistics regarding other animals have recently been made available through the labours of a Committee of the Statistical Society, which inquired into the question of the 'Production and Consumption of Meat and Milk.'\*

*Cattle.*—The *mortality* among cattle over 1 year old is 2·6 per cent. per annum, for calves it is 7·4 per cent. The average mortality among cattle of all ages is taken by the Committee at 4 per cent. The *birth-rate* is about 90 per cent., while 10 per cent. is the proportion of barrenness. The average milking life of a cow is about 5 years.

*Sheep.*—The *mortality* for sheep under 1 year old is 5·8 per cent., for those 1 year and over it amounts to 3·5 per cent. A general death-rate for sheep of all ages is 4·25 per cent. The *birth-rate* is taken by the Committee at 112 per cent., viz., as the number of lambs born to 100 ewes. Very much higher results than this have, however, been obtained in individual flocks.

*Pigs.*—The *mortality* is taken at 9 per cent. per annum; the *birth-rate* at an average of 11 per sow three times a year.

The economics of food-supply give the healthy pig a very short life; it has been estimated that the average life is about six months.

\* *Journal of Royal Statistical Society*, vol. lxxvii., Part III., 1904.

## APPENDICES

### APPENDIX I

AFTER the sheets dealing with the Eradication of Epizootic Diseases had passed through the press, new Orders dealing with Sheep Scabies (Sheep Scab Order of 1905, 6879; Sheep Scab (Compulsory Dipping Areas) Order of 1905, 6880; and Sheep Scab (Regulation of Movement) Order of 1905, 6881), were published.

The first Order (No. 6879) does not differ in principle from that of 1898, but provides, as may be seen from the quotations below, for the immediate detention of all sheep suspected to have scabies pending a veterinary examination, and increases the powers of Inspectors, both of the Board and the Local Authority, as regards the isolation of in-contacts.

‘An Inspector of a local authority on receiving, in any manner whatsoever, information of the supposed existence of sheep scab, or having reasonable ground to suspect the existence of sheep scab, shall proceed with all practicable speed to the place where such disease exists or is suspected to exist, and shall forthwith serve a Detention Notice.’

It will be noted that there is no option in the service of this notice, and on it the sheep are detained until a veterinary inspection is made.

‘An Inspector of the local authority may serve an Isolation Notice . . . on the owner or person in charge of any sheep which he has reason to believe to have been in contact with sheep affected with sheep scab.’

Such ‘in-contacts’ cannot then be moved for 56 days, unless dipped to the satisfaction of the Inspector.

The second Order (No. 6880) provides for a census of all sheep within any area declared to be a ‘Compulsory Dipping Area,’ and their detention within that area until they are dipped to the satisfaction of the authorities.

The third Order provides for the restriction of movement of sheep within a ‘Scheduled area,’ which may be any area decreed by the Board.

## APPENDIX II

### CATTLE PLAGUE

SINCE the section dealing with cattle plague passed through the press I have had the advantage of exchanging views with Mr. Stockman, Chief Veterinary Officer, Board of Agriculture. He considers the method of inoculating simultaneously with serum and virulent blood, or with bile, to be dangerous, even in the hands of an expert, owing to the risk of setting up fresh centres of infection.

He strongly urges the use of serum alone as a protective inoculation, and to guard against the short immunity serum gives, he advises the inoculation of the herd every ten days for a month, by which time all chances of further infection has passed.

According to this view, blood and serum inoculation should be reserved for countries where the disease is enzootic, and where, obviously, the only way to stamp it out is to establish permanent immunity.

The use in the United Kingdom of blood and serum, or bile, for use in the outer cordon, as recommended at p. 493, should in the light of this opinion be modified, and only serum used in the outer cordon.

Mr. Stockman urges that the length of time required for the production of protective serum has been unduly emphasized at p. 497; he has found it may be prepared in three weeks.

Dr. Theiler informs me, in connection with the disinfection of persons, that, apart from obvious disinfection, such as hands, it is sufficient if they change their boots, as the virus has a very short life outside the body.

The views expressed by me in the section dealing with cattle plague were those successfully employed in Cape Colony by Dr. Hutcheon and his staff, to whom I am indebted for learning how to deal with Rinderpest during the campaign in South Africa. For military purposes the risk of serum and virulent blood inoculation must be accepted; the serum method alone would be useless in war, owing to the brief protection afforded.

## APPENDIX III

### DECIMAL PARTS OF A FOOT.

12 inches	=	1.00	decimal part of a foot.		
11 "	=	.92	"	"	"
10 "	=	.83	"	"	"
9 "	=	.75	"	"	"
8 "	=	.67	"	"	"
7 "	=	.58	"	"	"
6 "	=	.50	"	"	"
5 "	=	.42	"	"	"
4 "	=	.33	"	"	"
3 "	=	.25	"	"	"
2 "	=	.17	"	"	"
1 "	=	.08	"	"	"

### LIQUID MEASURES.

The imperial gallon	=	10 lbs. water at 62° Fahr.
1 pint	=	34.66 cubic inches.
1 quart	=	69.318 "

### DRY MEASURES.

4 quarts	=	1 gallon.
2 quarts	=	1 pottle.
2 pottles	=	1 gallon.
2 gallons	=	1 peck.
4 pecks	=	1 bushel.
1 bushel	=	8 gallons.
8 bushels	=	1 quarter.

### MEASURES OF SURFACE AND SOLIDITY.

144 square inches	=	1 square foot.
9 " feet	=	1 " yard.
1728 cubic inches	=	1 cubic foot.
27 " feet	=	1 " yard.



According to Act of Parliament, a bushel is defined as a hollow cylinder having a plane base, the internal diameter of which is double the internal depth. The imperial bushel contains 80 lbs. weight of water.

1 bushel of Wheat is on an average 60 lbs.				
1	„	Barley	„	47 „
1	„	Oats	„	40 „
1	„	Oatmeal	„	50½ „
1	„	Peas	„	64 „
1	„	Beans	„	63 „
1	„	Malt	„	38 „
1	„	Linseed	„	53 „
1	„	Maize	„	66 „
1	„	Bran	„	20 „
1	truss of	Straw	„	36 „
1	„	old Hay	„	56 „
1	„	new Hay	„	60 „
1	load of	Hay or Straw	=	36 trusses.
Hay is considered new until 1st September.				

## INDEX

- ABATTOIRS**, 654  
     legislation, 658  
**Abortion amongst animals**, 30  
**Abortion, epizootic** 394, 616  
**Absorption method, excreta**, 379  
**Abyssinian Expedition**, 27  
**Acari**, 168  
     mange, 417  
*Acarina*, 416  
**Access pipe**, 368  
**Acetic acid**, 99  
*Achorion Schönleini*, 452  
**Acid works**, 37  
*Aconitum napellus*, 181, 182  
**Actinomycosis**, 452  
**Action of water on metal pipes**, 11  
**Adulteration of cakes**, 255  
*Æcidiospore*, 165  
*Æcidium berberidis*, 164  
**Aerobes, facultative**, 453  
     obligatory, 453  
*Æthusa cynapium*, 174  
**Aftermath**, 220  
**Agglutination**, 461  
**Air**, 31  
     acid works, 37  
     alkali works, 37  
     ammonia in, 34-89  
     amount of, required, 53  
     Argon, 33  
     aspiration, 64  
     bacteria and impure, 47  
     Beaufort scale, 80  
     Blackman air-propeller, 83  
     Boyle extractor, 73  
     carbonic acid in, 33  
     cattle, fresh air for, 59  
     Chaumont's equation, 56  
     composition of, 31  
     cubic space required, 57  
         for cattle, 61  
     decomposition impurities, 39  
     determination of organic matter,  
         88  
     direction of currents, 69  
     *Air—continued*  
         diseases produced by impure, 44  
         draughts, 57  
         estimation of carbonic acid, 87  
         examination of, by senses, 86  
         from manure pits, 39  
         impurities in, 35  
             from offensive trades, 36  
         in mines, 36  
         inlets and outlets, 67  
         McKinnell's tube, 76  
         mechanical ventilation, 82  
         micro-organisms in, 43  
         microscopical examination of, 89  
         Muir's tube, 75  
         nitrogen in, 33  
         of marshes, 40  
         offensive trades, 37  
         organic matters in, 34  
         oxygen in, 32  
         ozone in, 33  
         perflation, 63  
         respiratory organic matter, 42  
         respiration impurities, 40  
         size of inlets, 79  
         sulphuretted hydrogen in, 89  
         sulphurous acid in, 36  
         supply in mines, 56  
         suspended matters, 34  
         Tobin's tubes, 76  
         vitiation by combustion, 35  
         warming, 65  
         watery vapour in, 34, 89  
     'Air Space in Dairies and Cow-sheds,'  
         323  
     Air-bricks, 77  
     Albuminoid ratio, 97, 103  
     Albuminoids, 94  
     *Alexin* of Bordet, 459  
     *Alfalfa*, 227  
     Alkali works, 37  
     *Allium*, 183  
     *Alopecurus agrestis*, 209  
         *pratensis*, 209  
     *Amblyomma hebraeum*, 417, 615

- Amboceptor of Ehrlich, 459-461  
 American water hemlock, 176  
 Amides, 95  
 Ammonia carbonate, 42  
   in the air, 34  
   in stable air, 89  
   in water, 20  
 Amount of food required daily, 113  
 Anaerobes, facultative, 453  
   obligatory, 453  
 Analysis, grasses, 230  
   linseed, 252  
   maize, 241  
   oats, 240  
   peas, 249  
   roots, 264  
   straw, 235  
 Anemone group, 183  
 Angus Smith's test for CO<sub>2</sub>, 87  
 Animals, care and management of, 724  
   census, 938  
 Animal parasites affecting food, 167  
   *Anopheles*, 425  
   *Anthoxanthum odoratum*, 209  
 Anthrax, 50, 393, 481, 582  
   and fat horses, 155  
   and cremation, 414  
   infection, 30  
   legislation, 588  
   protective inoculation, 588  
   in linseed cake, 195  
   *Anthyllis vulneraria*, 229  
 Anti-bacterial serum, 459  
 Antitoxic serum, 457  
 Appendices, 1012  
 Abor vitæ, 193  
*Argas*, 168  
 Argon, 32  
 Arsenical dips, 520  
 Arthritis, epizootic, 628  
 Artificial grasses, 224  
 Artois, well at, 4  
*Ascaris vituli*, 676  
 Ash, 184  
*Aspergillus*, 166, 452  
*Astragulus lentiginosus*, 190  
*Atropa belladonna*, 178  
 Attendants, disinfection of, 410  
 Autumn crocus, 171  
*Avena flavescens*, 216  
 Avenin, 237  
 Azoturia, 153  
  
 Babcock's method (fat in milk), 709  
 Bacillary pyroplasma, 450  
*Bacillus anthracis*, 455  
   *cyanogenus*, 712  
*Bacillus* of glanders, 48  
*Bacillus radiccicola*, 389  
   *synacanthus*, 712  
  
 Backs, horses', shapes of, 814  
 Bacteria, 450  
   facultative, 47  
   obligatory, 47  
   metatrophic, 454  
   paratrophic, 455  
   prototrophic, 454  
   saprogenic, 454  
   zymogenic, 454  
 Bacteriaceæ, 450  
 Bacterial growth, conditions of, 453  
   products of, 454  
 Bacteriological examination of water,  
   16  
*Bacterium megatherium*, 455  
 Bails, compound, 312  
   deep, 313  
   simple, 312  
   swing, 303, 312  
 Barley, 245  
   malted, 246  
   and products, tables, 247  
 Bead tree, 193  
 Beans, 250  
   crushing of, 196  
 Beaufort wind-scale, 80  
 Becker-Ullman cooking or destroying  
   apparatus, 680  
 Beech, 184  
   nut, 193  
 Beet fly, 261  
 Beetroot pulp, 184  
 Bell trap, 373  
 Belooch mares, 244  
 Bhoot, 250  
 Bilious fever in horses, 417, 608  
*Biota orientalis*, 193  
 Birds as carriers of infection, 509  
 Birdsfoot trefoil, 227  
 Bits, fitting of, 826  
 Bitter-sweet, 180  
 Black bent, 209  
 Blackman air-propeller, 83  
 Blankets, disinfection of, 410  
 Blastomycetes, 453  
 Blinding Breeze Fly, 427  
 Blue-bottle flies, 432  
 Bokhara clover, 229  
 Bont-tick, 615  
*Bostrichus longus*, 168  
   *sperocephalus*, 168  
 Bot-flies, 427  
   treatment, 429  
*Botrytis grisea*, 166  
 Boussingault's tables, 120  
 Box and yard system of fattening, 342  
 Box feeding of cattle, 128  
 Boxwood, 184  
 Boyle extractor, 73  
 Boyle's system of air-supply, 65

- Bran, 101, 242  
   in diet, 119  
   mashes, 244, 270  
 Braxy, 593  
 Breaking horses, 729  
 Breast harness, 826  
 Breeding, hygiene of, 876  
   age, influence of, in, 893  
   breeder, the, 876  
   degeneration, 888  
   food, 896  
   general principles of, 882  
   inbreeding, 883  
   mating, 895  
   ' nicking,' 895  
   records, 897  
   selection of type, 881  
   suitability of climate, 877  
     of locality, 877  
     of surroundings, 879  
   telegony, 897  
   temperament, 888  
   unsoundness in, 884  
   water-supply in, 881  
 Brewers' grains, 246  
 Bricks, 277  
 Brine poisoning, 195  
*Bromus catharticus*, 186  
 Bronchial parasites, 439  
 Brucine test, 19  
 Bruised grain, 265  
 'Brushing' of horses, 782, 807  
 Buchan's disconnecting syphon, 372  
 Buckthorn, 184  
 Buckwheat, 184  
 Buffalo gnats of America, 427  
 Buffein machine, 256  
 Buildings for cattle, 318  
 Bull box, 337  
 Bulls, treatment of, 837  
 Bunt, 162  
 Butyric acid, 99  
 Byres, area of, 329  
  
 Cabbage, 263  
 Cake breakers, 268  
*Calandra gramina*, 169  
 Calcarene, 386  
 Calculation of diets, 148  
 Calf-house, 334  
 'Calf kill,' 179  
 Calf-pen, 337  
 Calf vaccine lymph, 643  
 Calves. *See* Cattle  
   breaking of, 836  
   diarrhœa in, 138, 595, 599  
   feeding of, 137  
   management of, 834  
   milk substitutes for, 138  
   weaning of, 126  
  
 Calvert's disinfecting powders, 403  
 Canadian hay, 222  
 Carbohydrates, 97  
 Carbolic acid, 403  
 Carbonic acid, 33  
   estimation of, 87  
 'Carceag' of Roumania, 449  
 Carrots, 263  
 Catarrh of horses, 600  
 Catarrhal mastitis, 691  
 Cattle, acclimatization of, 997  
   anthrax, *q.v.*  
   biliary fever, 604  
   boxes, 341  
   buildings for, 318  
   bulls, treatment of, 837  
   byre routine, 843  
   calves, *q.v.*  
   cattle-house routine, 847  
   courts, 343  
   cow-pox, 694  
   dairy inspection, 683  
   diet tables, 114  
   digestion tables, 107  
   Diseases Prevention Bill, 468  
   East Coast fever, 604  
   epizootic abortion, 616  
     arthritis, 628  
     heart-water, 615  
     ophthalmia, 631  
     osteo-malacia, 630  
   excreta, amount of, 357  
   fattening of, 123  
   feeding for breeding, 846  
     butcher, 840  
     exhibition shows, 845  
     mixture, 129  
     cows, 838  
   foot and mouth disease, 507  
   gall sickness, 610  
   grain-feeding of, 159  
   grazing and pasturing, 202  
   grooming of, 348  
   hæmo-albuminuria, 604  
   insurance in the Rhinns of Gal-  
     loway, 637  
   mastitis, 688  
   milk cows, feeding of, 133  
   milk substitutes, 834  
   mortality, 1011  
   Pasteurelloses, 599  
   plague, 28, 480, 490  
     appendix, 1013  
     department, 467  
     legislation against, 497  
   pleuro-pneumonia, 501  
     septic of calves, 599  
   quarter-evil, 590  
   rail transport, 929  
   road transport, 931

- Cattle—*continued*  
 'soiling,' 205  
 stalls, 324, 340  
 statistics, 1011  
 Texas fever, 604  
 trucks, disinfection of, 411  
 Tse-tse, 609  
 tuberculosis in, 573, 688  
 ventilation for, 61  
 water, quantity of, required, 27  
 'white scour,' 595
- Caustic lime, 404  
 Ceilings, 280  
 Cellulose, 99  
   digestion of, 108  
 Cercariae, 437  
 Cerealine, 242  
 Cervical abscess (horse), 755  
 Cesspits, 375  
 Cesspool pollution, 7  
 Cestodes, 435  
 Chaff, 264  
   instead of long hay, 144  
 Chamber of Agriculture, 468  
 Chapped legs, 735  
 Chaumont's equation, 56  
 Cherry laurel, 187  
*Cheyletus*, 168  
 Chloride of lime water, 402  
 Chlorine gas, 401  
   in water, 18  
 Cholera and water-supply, 2  
*Chrysops cacutiens*, 427  
*Cicuta maculata*, 176  
   *virosa*, 175  
*Cicer arietinum*, 249  
*Ciliata*, 447, 450  
*Ciliophora*, 447  
 Citric acid, 100  
 Clark's process for softening water, 13  
 Classification of waters, 9  
 'Clatting' of ewes, 860  
*Claviceps purpurea*, 165  
 Cleaning grain, 266  
 Cleansing of roots, 267  
 'Cleg-fly,' 427  
*Clematis flammula*, 183  
   *vitalba*, 183  
 Climate, 992  
   acclimatization, 997  
   atmospheric pressure, 995  
   bursattee, 998  
   cold winds, 996  
   natural immunity, 999  
   rain, influence of, 996  
   surra, 999  
   temperature, adaptation to, 994  
   tse-tse, 999  
   veda, 995  
   windstroke, 996
- Clipping ewes, 860  
   horses, 731  
 Clothing of horses, 732  
 Clover, Alsike, 226  
   Bokhara, 229  
   broad, 225  
   crimson, 226  
   Dutch, 225  
   Italian, 226  
   red, 225  
   sickness, 167  
   Swedish, 226  
   white, 225  
   yellow suckling, 226  
 Coal dust, 37  
   gas, 36  
*Coccaceae*: *Micrococcus*, 450  
   *Sarcina*, 450  
   *Staphylococcus*, 450  
   *Streptococcus*, 450  
*Coccidium cunicoli*, 449  
 Cocksfoot, 209  
*Ctenurus cerebri*, 436, 676  
*Colchicum*, 184  
   *autumnale*, 171  
 Colic, influence of work on, 142  
   horses', 779  
 Collars, 821  
 Compensation, 477, 502  
 Complement of Ehrlich, 459  
 Complementophile group, 459  
 Condition of horses, 761  
 Conditions affecting the digestibility  
   of food, 109  
   of assimilation, 156  
   of digestibility, 156  
*Conium maculatum*, 173  
 Conservation of farmyard manure,  
   358  
 Construction of habitations, 276  
 Contagious foot rot, 509  
   of sheep, 597  
   pneumonia, swine, 599  
 Cooking of food, 269  
 Cooltee, 161, 250  
 Coolthie, preparation of, 197  
 Copper in water, 22  
   smoke disease, 37, 793  
*Coriaria myrtifolia*, 183  
 Corn cockle, 194  
   crushing of, 197, 265  
   meters, 272  
   stalk disease, 183  
 Cotton cake, 254  
   seed, 521  
 Cowbane, 175  
 Cow-houses, 320  
   consideration of existing, 330  
   cubic space of, 321  
   flooring of, 326

- Cow-houses—*continued*  
 lighting of, 320  
 manger for, 325  
 position of stalls, 326  
 superficial area, 323  
 tying-up method, 325  
 ventilation of, 320
- Cowl exhaust, 74  
 extraction and inlet, 73  
 lobster back, 73
- Cow-pox, 694
- Cow-shed floor, 329
- Cows. *See* Cattle
- Cremation, 412
- Cresol, 404
- Crested dogstail, 209
- Crib-biting, 750
- Crow garlic, 183
- Crushing of grains, 196, 265
- Culicidae*, 425
- Cynoctomum Capense*, 190
- Cynosurus cristatus*, 209
- Cysticercus bovis*, 436, 674  
*cellulosa*, 436, 674  
*pisiformis*, 436  
*tenuicollis*, 436, 676
- Cytasis of Metchnikoff, 459
- Cytophile group, 459
- Cytotoxic serum, 461
- Dactylis glomerata*, 209
- Dairies, London, winter feeding in, 134
- Dairy inspection, 683  
 legislation, 697
- Damp-proof course, 276
- Darnel, 185  
 poisoning, 184
- Datura stramonium*, 181
- Deadly nightshade, 178
- Death camas, 183
- Decimal parts of a foot, 1014
- Denitrification, 392
- Destruction of condemned meat, 679
- Determination of organic matter, 88
- Diarrhoea of calves, 138, 599
- Dichapetalum cymosum*, 188
- Diet, essential, 113  
 of farm horses, 119  
 scale of, for horses, 118  
 sheet in stables, 146  
 subsistence, 113  
 sudden changes of, 145  
 variable, 114  
 working, 114
- Dieting, substitutional, 120
- Digestibility of food, 105  
 conditions affecting, 109  
 food-stuffs, 107  
 salts, 101
- Dip, Queensland, 424
- Dip trap, 373
- Dipping-tank for cattle, 422
- Dips, phenol, 521  
*See* Sheep
- Diptera*, 425
- Direction of air-currents, 70
- Diseases connected with food, 150  
 due to imperfect preparation of  
 food, 196  
 of Animals Act, 1894, 480  
 produced by impure water, 28
- Disinfection, 396  
 by acids, 400  
 by carbolic acid, 403  
 by caustic lime, 404  
 by cresol, 404  
 cremation, 412  
 disinfectants, 400  
 expert, need for, 398, 400  
 fumigation, 401  
 glands, 398  
 heat, 404  
 iron sulphate, 404  
 izar, 404  
 lysol, 404  
 mercuric chloride, 402  
 method of applying solutions,  
 406  
 of attendants, 410  
 of blankets, 410  
 of cattle-trucks, 411  
 of grooming utensils, 410  
 of hides, 412  
 of harness, 412  
 of hoofs, 412  
 of horse-boxes, 411  
 of leatherwork, 409  
 of ships, 411  
 principles of, 396  
 routine of, 408  
 scabies in horses, 399  
 swine fever, 398  
 water troughs, 409  
 zinc chloride, 404
- Disposal by incineration, 380  
 of excreta, 356  
 of sewage, 370
- Distillers' grains, 247  
 wash, 247
- Distoma hepaticum*, 437
- Distribution of food, 272
- Dogs, distemper of, 599, 874  
 canker of the ears, 874  
 docking, 873  
 exercise of, 872  
 feeding of, 868  
 housing, 872  
 ingrown nails, 874  
 malignant jaundice of, 417, 421

- Dogs—*continued*  
 management of, 867  
 mange, 874  
 Pasteurella, 599  
 Phisalix vaccine, 875  
 pyroplasmiasis, 418  
 rabies in, 619  
 tse-tse in, 609  
 washing of, 872  
 water for, 872  
 'worming' of, 873  
 Dogs' mercury, 183  
*Dolichos uniflorus*, 250  
 Donkey, pyroplasmiasis of, 609  
 Door handles, 292  
 latches, 292  
 Doors for large stables, 317  
*Dourine*, 447, 609  
 Drain-grenades, 381  
 Drains, 366  
 subsoil, 366  
 testing of, 380  
 traps for, 371  
 underground, 366  
 ventilation of, 371  
 Drainage, absorption method, 380  
 Draining soil, 394  
 'Dronk-gras,' 185  
 Dry cows, feeding of, 136  
 'D' trap, 373  
 Dundee air examinations, 43  
 'Dupla' sheltering cloths, 350
- Ear cockle, 168  
 East Coast fever, of cattle, 417, 422, 604  
*Echinococcus veterinarum*, 436, 676  
 Ehrlich's lateral chain theory, 457  
 Electric cleansing of corn, 162  
 Ellison's air-brick, 77  
 Emanations from manure-pits, 39  
 Ensilage, 231  
 Enteric and water-supply, 2  
 Enzymes, 454  
 Epizootic abortion, 394, 616  
 arthritis, 628  
 diseases due to Pasteurella, 599  
 pyroplasmiasis, 604  
 trypanosomata, 609  
 heart-water, 615  
 lymphangitis, 393, 453, 481, 625  
 ophthalmia, 631  
 osteo-malacia, 630  
 osteo-porosis, 629  
 Equine malaria, 608  
 Equines, care and management, 724  
*dourine*, 447, 609  
 epizootic diseases of. *See* Epizootic
- Equines—*continued*  
 glanders, *q.v.*  
 infectious pneumonia, 599  
 influenza, 599  
*Mal de cadenas*, 610  
*maladie de coit*, 610  
 malarial fever, 608  
 mallein, 560  
 pustular stomatitis, 624  
 quantity of water required, 27  
 scabies in, 529  
 South African horse-sickness, 611  
 Surra, 609  
 tetanus, 624  
 Tse-tse, 609 (*q.v.*)  
 ventilation for, 59  
*See* Horse  
*Equisetum palustre*, 185  
 Equivalents for substitutional dieting, 121  
 Ergot, 165  
 symptoms produced by, 170  
 Ergotized rye, 165  
*Ericaceae*, 178  
 Estimation of carbonic acid, 87  
*Euphorbia*, 183  
 'Everyday' immunity, 49  
 Examination of air, 86  
 of milk, 706  
 of water, 13  
 Excreta, daily amount of, 357  
 disposal of, 356  
 Experimental feeding work, 97
- Faba vulgaris*, 250  
 Facultative parasites, 416  
*Fadogia*, 189  
*Fagus sylvatica*, 193  
 Farcy, 564. *See* Glanders  
 in starved horses, 155  
 Fastening arrangements for horses, 302  
 Fat, 97  
 into starch, factor, 104  
 production of, 121  
 Fattening of cattle, early, 125. *See* Cattle  
 boxes, 341  
 Fermentation, 269  
*Fescues, v. Festuca*  
*Festuca durivaseula*, 212  
*elatior*, 212  
*ovina*, 209  
*pratensis*, 212  
*quadrivalvis*, 186  
 Field cremation, 477  
*Filaria equi*, 442  
*Evansi*, 443  
*immitis*, 443  
*inermis*, 443

- Filaria equi*—continued  
*irritans*, 443  
*labiato-papillosa*, 431, 442  
*lachrymalis*, 443  
*haemorrhagica*, 443  
*oculi*, 30  
*palpebralis*, 443  
*recondita*, 443
- Filtration of water, 12
- Fixateur of Metchnikoff, 459
- Flies, 425, *et seq.*  
*anopheles*, 425  
 beet, 261  
 blinding breeze-fly, 427  
 blue-bottle, 432  
 bot, 428  
 breeze, 426  
 buffalo gnats, 427  
*Chrysops cæcutiens*, 427  
 'cleg,' 427  
 forest, 434  
 gad, 426  
*Gastrophilus equi*, 429  
*haemorrhoidalis*, 430  
*Glossina morsitans*, 431  
*palpalis*, 432  
 green-bottle, 432  
*haematobia*, 431  
*Hæmatopota pluvialis*, 427  
*Hippobosca equina*, 434  
*rufipes*, 434  
 horn-fly, 431  
 horse bot-fly, 429  
 breeze-fly, 427  
 house fly, common, 431  
*Hypoderma bovis*, 428  
*lineata*, 428  
 'ked,' 433  
 louse-fly, 433  
*Lucilia Caesar*, 432  
*sericata*, 432  
*Melophagus ovinus*, 433  
*Musca domestica*, 431  
*Æstrus caricola*, 428  
*cuticula*, 428  
*gastricola*, 428  
*ovis*, 430  
 ox gad-fly, 426  
 ox warble, 428  
 sheep-louse-fly, 433  
 nostril-fly, 430  
*Simuliida columbaschense*, 427  
*meridionale*, 427  
 spider, 433  
*Tabanus bovinus*, 426  
 Tse-tse, 431  
 warble, 428
- Fluke disease, 394, 437
- Foals, early handling of, 724  
 feeding of, 147, 726
- Foals—continued  
 pasturing, 727
- Fodder, dry, digestibility of, 109  
 effect of storage on, 109  
 green, digestibility of, 109
- Fogs, London, 35
- Food and feeding, 90  
 amount of, required daily, 113  
 calculation of diets, 148  
 mechanical value of, 112  
 potential value of, 112  
 calves, 137  
 carbohydrates, 98  
 cellulose digestion, 108  
 classification of, 93  
 common salt, 101  
 composition of pasture grasses,  
 207  
 conditions affecting digestibility  
 of, 109  
 conditions of quality, 159  
 deficiency of, 154  
 digestive coefficient, 106  
 digestibility of, 105  
 diseases connected with, 150  
 due to imperfect preparation  
 of, 196  
 distribution of, 272  
 dry cows, 136  
 ensilage, 231  
 essential diet, 113  
 fat, 97  
 fat production, 121  
 fattening cattle, 123  
 farm horses, diet of, 119  
 foals, 147  
 frequent, 144  
 grains, 235  
 hay, 216  
 harmful substances, 171  
 heat-producing power of, 111  
 inorganic substances, 100  
 infection of, by specific germs, 195  
 maize in pig feeding, 133  
 manurial value of, 123  
 milch cows, 133  
 daily diet of, 136  
 mineral matter, 100  
 poisoning, 195  
 nitrogen tables, 96  
 nitrogenous substances, 93  
 non-nitrogenous substances, 97  
 nutritive ratio, 103  
 oil-cakes, 253  
 overfeeding, 153  
 parasites affecting, 162  
 animal, 167  
 vegetable, 162  
 phosphoric acid in, 101  
 pigs, 132



- Food and feeding—*continued*  
 poisonous plants, 171-194  
 poisonous substances, 171  
 potato poisoning, 194  
 preparing rooms, 338  
 stuffs, nitrogen in, 96  
*See Tables*
- Fool's parsley, 174
- Foot and mouth disease, 480, 494, 507  
 legislation, 512
- Foot of horse, hygiene of the, 798
- Forage inspection, 146
- Foreign animals, landing of, 639  
 Cattle Trade Association, 508
- Forest fly, 434
- Forging of horses, 786
- Foundations of habitations, 276
- Foxy grain, 167
- Freibank meat, 679
- Frequent feeding, horses, 144
- Fritillaria imperialis*, 183  
*meleagris*, 183
- Frost shoeing, 806
- Fumigation, 401
- Fungi affecting food, 162
- Furze, 229
- Gad-flies, 426
- Gall-sickness, S. African, 434, 609
- Gamasus fenorum*, 168
- Gambian horse disease, 609
- Gastrobium bilobum*, 191
- Gastrophilus equi*, 429  
*hemorrhoidalis*, 430
- Geological formations and water, 10
- Germination, 246
- 'Gift-blaar,' 188
- Girth galls, 320
- Githago segetum*, 194
- Glanders, 28, 44, 46, 48, 481, 552  
 and starved horses, 155  
 disinfecting in, 399  
 eradication of, 568  
 legislation, 569
- Glasgow water, 5
- Globulins, 94
- Glossina morsitans*, 431  
*palpalis*, 432
- Glycerinated lymph, 645
- Goat, epizootic heart-water, 615  
 osteo-malacia, 631  
 infectious pneumonia, 599
- Gorged stomach, 143
- Goitre, 30
- Gold chloride test, 21
- Golden oat-grass, 216
- Gorse shoots, preparation of, 198
- Grain, bruised and crushed, 265  
 cleaning of, 266  
 'foxy,' 167
- Grains, 235  
 brewers', 246  
 distillers', 247  
 for dairy stock, 159  
 for milk production, 134  
 'Gram,' 249  
 preparation of, 197
- Gramineæ*, 198, 235
- Grass, 198  
 as a diet, 206  
 land, 198
- Grasses, artificial, 224
- Gratiola officinalis*, 183
- Grazing, 202
- Greedy feeding, horses, 197
- Green-bottle flies, 432
- 'Green meat,' 197
- Green sugar-sorghum, 183
- Greener's patent killer, 721
- Grooming horses, 735
- Ground water, 387
- Gruel, 272
- Guadeloupe, mal de*, 452
- Guillotine, for animal slaughter,  
 663
- Guinea Corn of Barbadoes, 184
- Gully trap, 374
- Habitations, 273  
 aspect, 274  
 buildings for cattle, 318  
 bull-box, 337  
 calf-house, 334  
 cattle stalls, 340  
 ceilings, 280  
 construction, 276  
 cow-houses, existing, considera-  
 tion of, 330  
 foundations, 276  
 hospitals, 351  
 inside walls, 280  
 lighting, 280  
 paving, 282  
 piggeries, 345  
 roofing, 277  
 sheep shelters, 348  
 site, 274  
 soil, 274  
 stables, 286
- Hæmaphysalis leachi*, 417
- Hæmatobia*, 431
- Hæmatopinus*, 434
- Hæmatopota pluvialis*, 427
- Hæmo-albuminuria (Texas fever),  
 156, 604
- Hæmoglobinuria, 417, 449
- Hæmolytic serum, 461
- Hæmoproteus Danilewsky*, 449
- Hæmoproteus*, diagram, 448
- Hæmorrhagic septicæmias, 599

- Hæmosporidia, 449  
 Hammels, 339  
     flooring of, 285  
 Hand feeding of calves, 137  
 Hands, disinfection of, 693  
 Haptines, 462  
 Haptophore, 457  
 Hard fescue, 212  
 Hardness of water, 10, 17  
     removal of, 13  
 Harness, 811, 821  
 Hay, 216  
     amount of, to be given, 224  
     badly saved, 223  
     Canadian, 222  
     dusty, 223  
     'mow-burned,' 223  
     musty, 223  
     new and old, 222  
     rack, 301  
     varieties of, 221  
 Hazel, 184  
 Head-ropes as carriers of infection, 509  
 Heart-water, 417-418, 421-422  
 Heat, disinfection by, 404  
 Heat-producing power of food, 111  
 Height of stables, 60  
*Helleborus niger*, 181  
 Helminths, 435  
 Hemlock, 173  
 Henbane, 181  
 Hendon eruption, the, 694  
 'Hide-bound' horses, 158  
*Hippobosca equina*, 434  
     *rufipes*, 434  
*Hippoboscidae*, 433  
*Homeria pallida*, 187  
 'Hoose,' 439  
 Hop trefoil, 226  
 Horse. *See also* Equines  
     accidents, due to work, 778  
     amount of labour, 773  
     backs, shape of, 814  
     bedding, 741  
     bilious fever, 417, 608  
     bits, fitting of, 826  
     bot-fly, 429  
     boxes, disinfection of, 411  
     breaking, 729  
     breast harness, 826  
     breeze-fly, 427  
     'brushing,' 780, 807  
     care of the, 724  
     care of the legs, 734  
     chambering saddles, 820  
     carrying power of, 773  
     cast, 757  
     clipping, 731  
     clothing, 731  
     Horse—*continued*  
     collar injuries, position of, 825  
     collars, 821  
         after-wale of, 823  
         fitting, 822  
         fore-wale of, 823  
     condition, 761  
     conformation of, 145  
     cubic space for, 59  
     diet tables, 113, 118  
     digestion tables, 107  
     diseases arising from bad shoe-  
         ing, 809  
         neglect, 810  
         due to work, 778  
         special callings, 791  
     draught, 811, 827  
     early handling of, 724  
     exportation of, 924  
     excreta, amount of, 357  
     farm, diet of, 119  
     feeding, 726, 747  
     flesh, sale of, 683  
     foot, hygiene of the, 798  
     forging, 786  
     friction, effect of, 775  
     frost-shoeing, 806  
     girth-galls, 820  
     grooming, 735  
     hanging back in the stable, 758  
     harness, 811, 821  
         breast, 826  
     heel-galls, 757  
     'horse-power,' 776  
     injuries caused by lying down,  
         744  
         to feet arising from work,  
             810  
     inspiration of, 41  
     jibbing, 795  
     lameness, 787  
         in war, 967  
     laminitis, 157, 770  
     navicular disease, 787  
     normal daily work, 777  
     over-reaching, 786  
     panic, 793, 969  
     Pasteurelloses of, 599  
     pneumatic pannels, 821  
     rail transport, 927  
     remount depôt, 971  
     rest of, 143  
     road transport, 931  
     roads, effect of, 830  
     roughing, 806  
     running away, 794  
     sand-bed for cleaning, 737  
     saddles, 811  
         chambering of, 820  
         fitting of, 818

Horse—*continued*

- saddles, injuries caused by, 814
  - scale of diets for, 118
  - shoeing, 802
  - shoe to prevent stumbling, 783
  - shying, 795
  - sickness, 388
  - slipping up, 756
  - sore backs, 962
  - speedy cut, 783
  - sprains, cause of, 769
  - springs, effect of, 830
  - stable injuries, 755
    - sprains, 758
    - vices, 750
  - stabling, 273
  - stampedes, 793, 969
  - statistical inquiry, 1000
  - stuffing saddles, 821
  - stumbling, 780
  - subsistence diet of, 113
  - transport of, 899
  - troop, 963
  - ventilation for, 747
  - vices of working horses, 793
  - washing, 739
  - watering, 747
  - Watts' experiment, 774
  - wear and tear, 759
  - weight carried by, 963
  - where the weight should be carried, 817
  - work, amount of, 116
- Hospitals, 351
- Housing of fattening stock, 339
- Huddersfield water, 11
- Human hygiene, errors of, 634
- Humane slaughtering of animals, 662
- Humic acid in water, 12
- Humus, 386
- Hunger weed, 209
- 'Husk,' 439
- Hydrogen sulphide in water, 22
- Hygiene, object of, 29
- Hygienic classification of water, 9
- Hyoscyamus niger*, 181
- Hyphomycetes, 452
- Hypoderma bovis*, 428
- lineata*, 428
- Impurities, in air, 35
- in water, 9
- Immunity, 446, 457
- 'everyday,' 49
- methods of producing, 463
- lateral chain theory, 457
- phagocyte theory of, 462
- Incineration, disposal by, 380
- Incinerators, 414
- 'In-contact,' definition of, 489

- India, diet of horse in, 152
  - Indian water-tanks, 6
  - Infection, 446, 455
  - Infectious diarrhoea of calves, 595
    - diseases common to animals and man, 632
    - pneumonia, horse, 599
  - Influenza, 394
    - horse, 599
  - Inoculation against rinderpest, 496
  - Inorganic substances in food, 100
  - Inspection of animals prior to slaughter, 663
  - Insurance, 478, 635
  - Interstitial mastitis, 692
  - Intestinal calculi, 161
  - Intestines. ratio of length to body length, 91
  - Iron in water, 22
    - sulphate, 404
  - Italian rye grass, 212
  - Isodes veduvius*, 417
  - Ivalide*, 417
  - Izal, 404
- Jersey cattle, 840
- Jibbing, 795
- Kaffir corn, 184
- Kale, thousand-headed, 263
- Kalmia angustifolia*, 179
- Kalning, 560
- 'Ked,' 433
- Kicking (horses), 751
  - log, 753
- Kidney Vetch, 229
- Klimop, 190
- Knackeries, 716
- Kohl-rabi, 263
- Lameness of horses, 787
  - in war, 967
- Laminitis, 157, 770
- Landing of foreign animals, 639
- Larkspur, 123
- Lathyrus sativus*, 193
- Laurel, 187
- Lay inspectors, 471
- Lead for stable floors, 285
  - in water, 22
  - pipes, action of water on, 11
- Lead poisoning, 195
- Leather work, disinfection of, 409
- Leclainche's method of immunization, 552
- Leeches, 30
- Legislation, 466
  - Anthrax, 588
  - cattle by rail, 929
  - by road, 932

Legislation—*continued*

- Cattle Plague, Appendix, 1013  
Order, 497  
Dairies, etc., 697  
Diseases of Animals Act, 481  
Epizootic Lymphangitis, 627  
Exportation of Horses, 924  
Foot and Mouth Disease, 512  
Foreign Animals, 639, 925  
Glanders, 569  
Habitations, 354  
Inspector of Nuisances, 649  
Manchester Local Act, 704  
Markets, etc., 723  
Parasitic Mange, 534  
Pleuro-pneumonia, 505  
Rabies, 622  
Regulation of Ports, 484  
Sheep-pox, 515  
Sheep Scab, 527 ; Appendix, 1012  
slaughter-houses, 658  
Transport of Animals, 922  
Tuberculosis, 582  
Length of head-collar fastening, 304  
*Lessertia annularis*, 190  
Leucin, 95  
*Leucothoe Catesbawi*, 179  
Lice, 434  
Lighting, 280  
Lignin fibre, 99  
Lime in water, 17  
*Limnæa truncatula*, 437  
Linseed, 251  
    cake, preparation of, 198  
    in dieting, 146  
    preparation of, 197  
Liquid manure tanks, 375  
Litter shed, 317  
Liver fluke of sheep, 30, 394, 437  
Loam, 385  
Local authorities, 471  
    object-lesson, 501  
Local Government Board bye-laws re  
    'keeping animals,' 354  
Loch Katrine water, 5  
'Loco' disease weed, 190  
*Lolium italicum*, 212  
    *perenne*, 212  
    *temulentum*, 185  
London, strata beneath, 4  
Loose-box division, 298  
Lorenz's method of immunization, 552  
*Lotus corniculatus*, 227  
'Louping-ill,' 417, 594  
Louse-flies, 433  
Lucerne, 226  
*Lucilia Caesar*, 432  
    *sericata*, 432  
Lupine, 194, 229  
Lupinotoxin, 194  
Lymphangitis, epizootic. *See* Epizootic
- Macdougall's disinfecting powders, 403  
Macrophages, 462  
Maceration of grains, 268  
'Maggot' in sheep, 432  
Magnesia in water, 18  
Maize, 240  
    analysis of, 241  
    crushing of, 196  
    in pig feeding, 133  
    in pregnancy, 117  
*Mal de cadenas*, 447, 609  
*Maladie de coit*, 447, 609  
Malaria, 382  
Malarial catarrhal fever of sheep, 603  
    fever of equines, 604  
Malic acid, 100  
Malignant apthæ (sheep), 509  
    jaundice, dog, 417, 420  
    œdema, 393  
Mallein, 560, 982  
Mammitis, infective, of ewes, 860  
Man, infective diseases common to  
    animals and, 632  
Mange in equines, 530  
    in starved horses, 155  
    in war, 966  
Mangels, 261  
Mangers, 299  
    for industrial stables, 315  
Manure-pits, 40  
Manure-sheds, 375  
Manurial value of foods, 123  
Mares, pregnant, feeding of, 147  
Markets, 722  
Marl, 386  
Mashes, bran, 270  
*Mastigophora*, 417  
Mastitis, acute parenchymatous, 691  
    catarrhal, 691  
    contagious, 692  
    forms of, 688  
    interstitial, 692  
    traumatic, 692  
    tubercular, 688  
McKinnell's air-tube, 76  
Meadow and pasture grasses, 208  
    catstail, 216  
    fescue, 212  
    foxtail, 209  
    land, 199  
    saffron, 171  
Measurements of cubic contents, 84  
Measures, 1015  
Meat, condemned, utilization of, 679  
    inspection, 649  
    farce of, 650  
    method of, 664

- Meat inspection, parasitic diseases, 674  
 inspectors, 475  
 poisoning, 678
- Meat-flies, 432
- Mechanical value of foods, 112  
 ventilation, 82
- Medicago lupulina*, 226  
*sativa*, 226
- Melia azedarach*, 193
- Meliga dendroides*, 185
- Melilot, 229
- Melilotus officinalis*, 229
- Melophagus ovinus*, 433
- Mercuric chloride, 402
- Meta-phenylenediamine test, 19
- Metchnikoff's theory of immunity,  
 50, 462
- Microbes, 446
- Micrococcus*, 450  
*proligiosus*, 712  
*pyogenes*, 451
- Micro-organisms in inhabited rooms,  
 44  
 in soil, 390
- Microphages, 462
- Microscopical examination of stable  
 air, 89  
 of water, 15
- Middlesbrough pneumonia outbreak,  
 679
- Milch cows, feeding of, 133-136
- Mildew, 163-164
- Military hygiene, 933  
 cavalry, second horse for, 965  
 census needed, 938  
 Corunna campaign, 962  
 'crush,' the, 977  
 defective shoeing, 968  
 disposal of dead, 987  
 exercise, 983  
 exhaustion, 959  
 food supply, 954  
 forges, 981  
 glanders in war, 966  
 German care of horses, 961  
 hay nets, 957  
 heel-rope gall, 948  
 horse-mastership, 936  
 hospitals, 941, 985, 987  
 Italian ring, 949  
 linking, 949  
 losses, animal, in war, 958  
   under fire, 967  
 man-at-arms, 964  
 mangle in war, 966  
 mangers, 958  
 march, attention during, 951  
 marking army horses, 991  
 new arrivals at depôt, 982  
 nose-bags, 957
- Military hygiene—*continued*  
 Peninsular War, 961  
 picketing, 948  
 registration scheme, 937  
 remount depôts, 971, 985  
 remounts, 937  
 sanitation of camps, 947  
 shoeing, 950, 968  
 sore backs, 962  
 stables, home, 939  
   Indian, 939  
   South African, 940  
 supply of horses, 936  
 tattooing army numbers, 991  
 Theodosian code, 963  
 total losses of horses in war, 970  
 training, essentials of, 941  
 weight carried by cavalry horse,  
 963
- Milk, average composition of, 706  
 butyric bacillus, 711  
 epidemics, 713  
 examination of, 706  
 lactic acid organism, 711  
 Pasteurization of, 715  
 sources of contamination, 709  
 specific gravity of, 708  
 substitutes, 834  
 supply of towns, 715  
 trade legislation, 697
- Millers' horses and intestinal calculi,  
 161
- Milletts, 244
- Mineral matter in food, 100  
 poisoning, 195
- Model regulations, L.G.B., dairies,  
 etc., 322  
 set of food-preparing machinery,  
 271
- Molinea cœrulea*, 186  
 'Moor-ill,' 184
- Mouldiness, 166
- Moulds, 452  
 'Mow-burned' hay, 219
- Mucor*, 166, 452
- Mud fever, 735
- Muir's air-shaft, 75
- Mules, sand-bed for, 737
- Municipal hygiene, 647  
 Dairies, etc., Order, 697  
 dairy inspection, 683  
   stock, inspection of, 688  
 destructors, 680  
 enlightened cities, 685  
 Freibank meat, 679  
 Glasgow, local powers, 704  
 horse-flesh, sale of, 683  
 Hendon eruption, 633, 694  
 Infectious Diseases (Prevention)  
 Act, 702

- Municipal hygiene—*continued*  
 inspection of animals prior to slaughter, 663  
 knackeries, 716  
 legislation, existing and proposed, 695  
 markets, 722  
 meat, condemned, statistics of, 676  
   utilization of, 679  
 meat inspection, 648  
   method of, 664  
 meat poisoning, 678  
 milk, care of, 712  
   epidemics, 713  
   examination of, 706  
   sources of contamination, 709  
   supply of towns, 715  
 milk-trade legislation, 697  
 pathological changes in flesh, 670  
 slaughter, inspection of animals prior to, 663  
 slaughter-houses, 654  
   legislation, 658  
 slaughtering animals, methods of, 661  
   tubercle bacilli in milk, 690  
 tuberculous meat, destruction of, 672  
 Veterinary Officer of Health, 647  
*Musca domestica*, 431  
*Muscidae*, 431  
 Mutters, 193  
 Myron, 257  
 Myronic acid, 257
- Natural ventilation, 62  
 Navel-ill, 394, 859  
 Needle-grass, America, 193  
 Nematode worms, 168  
 Nematodes, 439  
*Nerium oleander*, 187  
 Nessler's test, 20  
*Nicotiana tabacum*, 181  
 Nitrification, 391  
 Nitrifying ferment, 391  
 Nitrous acid in water, 19  
 Nitrogen, 33  
   in food-stuffs, 96  
 Nitrogenous ratio, 97, 103  
   substances in food, 93  
 Non-nitrogenous substances, 97  
 Normal moderate work of horse, 116  
 Nutritive ratio, 103
- Oat hair calculi, 161  
 Oats, 236  
   analysis of, 240  
   bad, 239
- Oats—*continued*  
   'foxy,' 239  
   kiln-dried, 238  
   method of feeding with, 240  
   old and new, 238  
   weight of, 239  
 Obligatory parasites, 416  
*Oenanthe crocata*, 176  
   *fistulosa*, 178  
   *phellandrium*, 176  
 Oesophagus, impaction of, 267  
*Oestridae*, 427  
*Oestrus caricola*, 428  
   *cuticola*, 428  
   *gastricola*, 428  
   *ovis*, 430  
 Offensive trades, 36  
*Oidium albicans*, 453  
   *aurum*, 167  
 Oil, addition of, to diet, 110  
 Oil-cake, 101, 253  
   amount given, 259  
   digestibility of, 259  
   diseases produced by, 258  
 Oleander, 187  
 Oleaginous seeds, 251  
*Onobrychis sativa*, 227  
 Oocyst, 449  
 'Oorud,' preparation of, 197  
 Open board roof, 279  
 Ophthalmia, epizootic, 631  
 Oregon henlock, 176  
 'Orf' in Scotland, 509  
 Organic acids, 99  
   matter, determination of, 88  
   in the air, 34  
 Organization of remount depôts, 971  
*Oribata*, 168  
*Ornithoglossum glaucum*, 191  
 Osteo-porosis, epizootic, 629  
   -malacia, epizootic, 630  
 Over-feeding, 153  
 Over-reaching of horses, 736  
 Ox 'gad-fly,' 426  
   warble, 428  
 Oxalic acid, 100  
 Oxen, subsistence diet of, 114  
 Oxidizable matter in water, 21  
 Oxygen, 32  
 Ozone, 33
- Panic, 793, 969  
 Parasites, 415  
   affecting food, 162  
 Parasitic diseases spread by water, 30  
 Parasitic gastro-enteritis of sheep, 441  
 Parasitic inflammation of the fourth stomach of ruminants, 441  
 Parasitic Mange (Ireland) Order, 534  
   in equines, 481

- Parched barley, 159  
 Parching barley, 270  
 Parenchymatous mastitis, acute, 691  
*Parinarium*, 189  
 Parsnips, 263  
*Pasteurella equi*, 600  
 Pasteurelloses, 599  
 Pasteurellosis, 595  
 Pasteur's method, immunization,  
   swine erysipelas, 552  
 Pasture grasses, 200  
 Pasture lands, 199  
 Pasturing, 202  
 Pathogenic organisms, 446  
 Pathological changes which render  
   flesh unfit for food, 670  
 Pavements, comparative safety of, 830  
 Paving, 363  
 Paving brick, 282  
 Peas, 248  
   crushing of, 196  
 Peat moss as bedding, 743  
 Peaty water, 12  
 Pectin, 260  
*Penicillium*, 452  
   *glaucum*, 166  
 Peppercorn, 168  
 Percolation of rain, 3  
 Perennial rye-grass, 212  
 Permissive legislation, 471  
 Pettenkofer's process for CO<sub>2</sub>, 87  
 Phagocyte theory of immunity, 462  
*Phleum pratense*, 216  
 Phonendoscope, 503  
 Phosphoric acid, 100  
 Phosphoric acid in water, 21, 23  
 Physical examination of water, 14  
 Picketing, 948  
 Piggeries, 345  
 Pigs, feeding, 132  
   on dairy farms, 338  
 Pink eye, 600  
 Pipes, 366  
*Pisum arvense*, 248  
 Pit ponies, 37  
*Plasmodium malaria*, 449  
   *precox*, 449  
   *vivax*, 449  
*Plasmodroma*, 447  
 Pleuro-pneumonia, 480, 501  
   legislation, 505  
   septic, of calves, 599  
 Pneumo-enteritis of sheep, 599  
 Pneumonia, infectious, horse, 599  
 Pneumonia on board ship, 51  
   contagious, of swine, 599  
*Poa pratensis*, 216  
   *trivialis*, 216  
 Podewill destructor, 681  
 Poison pea of Australia, 191  
 Pole-axe, the, 721  
 Pollards, 242  
 Poll-evil, horse, 755  
 Polyvalent serum, 464  
 Porcupine grass, America, 193  
 Potatoes 264  
   boiling of, 197  
   poisoning by, 194  
   poisonous, 181  
 Potential energy of foods, 112  
 Precipitines, 461  
 Preparation of food, 264  
   methods, 109  
 Principles of feeding horses, 139  
 Production of fat, 121  
 Propionic acid, 99  
 'Protection in disguise,' 508  
 Protective inoculation (pleuro-pneu-  
   monia), 503  
 Proteid, feeding with, 96  
 Proteids, 93  
*Protozoa*, 425  
*Protozoa*, 447  
*Pseudalius ovis*, 439  
*Psocus pulsatorius*, 169  
   *veloce*, 169  
*Psoroptes*, 424  
 Psoroptic mange, 530  
*Pinus fur*, 168  
 Public Health Act, 354  
*Puccinia graminis*, 163  
*Pulicidae*, 435  
 Pulmonary parasites, 439  
 Pulses, 248  
 Purging pastures, 206  
 Purification of water, 12  
 Purpura, 600  
 Purples, 168  
 Pustular stomatitis, 624  
*Pyroplasma bigeminum*, 449  
   *canis*, 449  
   *equi*, 449  
   *ovis*, 449  
   *parrum*, 450  
 Pyroplasmosis, dog, 418  
 Qualitative examination of water, 16  
 Quantity of water required, 27  
 Quarter-evil, 50, 393, 590  
   protective inoculation, 592  
   seton for, 591, 837  
 Queensland Dip, 424  
 Rabies, 471, 481, 619  
 Rainfall in England, 5  
 Rain-water, 1, 3  
 Rape, 263  
 Rape-cake, 253, 257  
 Rape-seed, 251  
*Ranunculaceae*, 181

- Ranunculus acrid*, 184  
*acris*, 181  
*flammula*, 181  
*lingua*, 181  
*scleratus*, 181  
 Rattle weed, 190  
 Reaction of water, 17  
 Red Water, 604  
 Regularity in feeding, 133  
 Remount depôts, 971  
 Respiratory impurity, 40, 55  
     organic matter, 42  
*Rhipicephalus appendiculatus*, 417  
     *annulatus*, 417  
     *Australis*, 417  
*Rhizopoda*, 447  
 Rhodesian redwater, 417, 420, 449,  
     604  
 Rhododendron, 187  
 Rice, 244  
 Rinderpest *v.* cattle plague, 491  
 Ringworm, 443  
 River water, 6  
*Rhus coriaria*, 183  
 Roads, hygienic inspection of, 830  
 Roofs, open board, 279  
 Roofing, 277  
 Roots, 259  
     cleansing of, 267  
     pulpers, 267  
     pulping and slicing, 196  
     slicers of, 267  
 Rothamsted experiments, 121, 199  
     silage, 233  
 Roughing horses, 806  
 Rough-stalked meadow grass, 216  
     ' Ruhr, die rote,' 449  
 Running away of horses, 794  
 Rust, 163  
 Rye, 244  
  
*Saccharomyces farciminosus*, 453  
 Saddle injuries, 814  
 Saddles, 811  
     chambering, 820  
     fitting, 818  
     pneumatic pannels, 821  
     side, 819  
     stuffing, 821  
 Sainfoin, 227  
 Saliva, amount of, taken up by foods,  
     139  
 Salmca, 250  
 Salt, addition of, to diet, 111  
 Salt, common, 101  
     ' Sand apple,' 189  
 Sand crack, 810  
 Sarcina, 450  
*Sarco-cystis Bertrami*, 450  
     *Blanchardi*, 450  
     *Sarco-cystis Miescheriana*, 450  
     *t-nella*, 450  
*Sarcoptidae*, 417, 424  
*Sarcoptina*, 424  
 Sarcoptes, 424  
 Sarcoptic mange, 530  
*Sarcosporidia*, 450  
 Satire on Veterinary Hygiene, 38  
 Sawdust as bedding, 743  
 Scalies in equines, 529  
     prevention of, 531  
     treatment of, 533  
     in sheep, 516  
 Scale of diets for working horses, 118  
 Schweineseuche, 464  
*Sclerotinia ciborioides*, 167  
 Seedy toe, 803, 809  
 Selection of site, 395  
 Septic pleuro-pneumonia of calves,  
     599  
 Serradella, 229  
 Serum, antibacterial, 459  
     antitoxic, 457  
     cytotoxic, 461  
     hæmolytic, 461  
     polyvalent, 464  
 Sesame cake, 256  
 Seton for calves, 591, 837  
 Sewage, disposal of, 370  
     farms, 39  
 Sewer air, 39  
 Sewers, 369  
 Sheep, abortion, 616, 856  
     aphtha, 858  
     brain hydatid, 436  
     braxy, 593  
     castration, 861  
     ' clatting,' 860  
     clipping, 860  
     contagious foot-rot, 597  
     diet tables, 114  
     digestion tables, 107  
     dip, Queensland, 424  
     dipping, 422, 525, 862  
     dips, 520, 521  
     docking, 861  
     epizootic, abortion, 616  
         arthritis, 628  
         heart-water, 615  
         osteo-malacia, 630  
     excreta, amount of, 357  
     fattening, 131  
     feeding of, 849  
     fescue, 209  
     foot and mouth disease, 507  
     ' gid ' in, 436  
     grazing and pasturing, 203  
     green diarrhoea, 858  
     infectious mammitis, 860  
     lambing season, 857



- Sheep—*continued*  
   lambs, feeding of, 854  
   laurel, 179  
   liver fluke, 30, 437  
   louping-ill, 417, 594  
   louse-fly, 433  
   ' maggot ' in, 432  
   malarial catarrh, 603  
   manumitis, infective, 860  
     sporadic, 860  
   management of, 849  
   maturity, early production of,  
     853  
   mortality, 1011  
   navel-ill, 859  
   neglected feet, 861  
   nostril fly, 430  
   ' Orf ' in, 509  
   parturient septicaemia, 859  
   Pasteurelloses, 599  
   pneumo-enteritis of Argentine,  
     599  
   pox, 470, 480, 514  
     legislation, 515  
   quarter-evil, 590  
   scab, 1012  
   scabies, 469, 481, 516  
   shelters, 348, 855  
   stells, 855  
   subsistence diet of, 114  
   underlocking, 860  
   weaning, 855  
   white skit, 858  
   wool balls in stomach, 860  
 Sheffield water, 11  
 Shelter cloths, 350  
 Sheringham ventilating windows, 68  
   window, 281  
 Ship disinfection, 411  
 Shoeing, 802  
   defective, in war, 968  
   diseases arising from bad, 809  
   frost, in war, 969  
   *See* Horse  
 Show cattle, mixture, feeding, for, 129  
 Shying, 795  
 Silage for milch cows, 135  
   sour and sweet, 232  
 Silica in water, 11  
 Silos, 231  
*Simulivida columbaschense*, 427  
   *meridionale*, 427  
*Simulivida*, 425  
 Site for habitation, 274  
 Slang-kop, 191  
 Slaughter-houses, 654  
 Slaughtering animals, methods of, 661  
 Sleeping sickness of Uganda, 432  
 Sleepy grass, 187  
 Slender foxtail, 209  
 Smooth-stalked meadow-grass, 216  
 Smut, 163  
 Snake head, 191  
 Soap liniment (B.P.) for testing, 18  
   ' Soiling,' 127, 205  
 Soils, 382  
   air in, 388  
   calcarene, 386  
   draining, 394  
   geologically, 384  
   ground water, 387  
   humus, 386  
   loam, 385  
   marls, 386  
   micro-organisms, 390  
   selection of site, 395  
   soil temperature, 390  
*Soja hispida*, 250  
*Solanacca*, 179  
*Solanum Dulcamara*, 180  
   *nigrum*, 181  
 Sore throat, horses, 600  
*Sorghum vulgare*, 184  
 South African horse-sickness, 611  
 Spear-grass of India, 193  
 Specific contagious mastitis, 692  
   germs, infection of food by, 195  
   ' Speedy cut ' of horses, 783  
 Spider-flies, 433  
*Spirillaceae*, 450  
   *spirillum*, 451  
   *spirochaete*, 451  
   *vibrione*, 451  
*Spiroptera megastoma*, 443  
   *microstoma*, 443  
   *reticulata*, 443  
 Sporidia, 165  
 Sporozoa, 447-448, 450  
 Spray-pumps, 406  
 Springs, 4  
 Spruce laurel, 184  
 Stable doors, 289  
 Stable, 286  
   height of, 60  
   high class, 287  
   industrial, 306  
   inside walls, 293  
   large *v.* small, 57  
   middle class, 306  
   pavilion system, 308  
   roof of, 293  
   stall divisions, 294, 306  
   windows for, 288  
 Stall feeding of cattle, 128  
 Stalls, length and width of, 297  
 Stampede, horses, 793  
*Staphylococci albus, aureus, cecreus*  
   *albus*, 646  
 Staphylococcus, 450  
 Starch, 98

State hygiene, 466  
 anthrax, 582  
   legislation, 588  
   protective inoculation, 592  
 Board of Agriculture, 472  
 braxy, 593  
 calf vaccine lymph, production of, 643  
 cattle plague, 490  
   department, 467  
   Diseases Prevention Bill, 468  
 Chamber of Agriculture, 468  
 compensation, 477, 502  
 contagious foot-rot of sheep, 597  
 definition of 'in-contact,' 488  
 Diseases of Animals Act, 1894, 480  
 earliest Act, 469  
 epizootic abortion, 616  
   arthritis, 628  
   diseases due to *Pasteurella*, 599  
   pyroplasmoses, 604  
   trypanosomata, 609  
 lymphangitis, 625  
   legislation, 627  
 ophthalmia, 631  
 osteo-malacia, 630  
 osteo-porosis, 629  
 equines, scabies in, 529, 531, 534  
 field cremation, 477  
 foot and mouth disease, 507  
   legislation, 512  
 glanders, 552  
   compensation, 564  
   legislation, 569  
 group system, 495  
 infectious diarrhoea of calves, 595  
   diseases common to animals and man, 633  
 inoculation against rinderpest, 496  
 insurance, 478, 635  
 landing of foreign animals in Great Britain, legislation, 639  
 lay inspectors, 471  
 local authorities, 471, 486  
 louping-ill, 594  
 malarial catarrhal fever of sheep, 603  
   protective inoculation, 603  
 Market and Fair (Swine Fever) Order, 474  
 measures and Act on which based, 480  
 meat inspectors, 475  
 Orders, number of, 481  
 permissive legislation, 471  
 pleuro-pneumonia, 501

State hygiene—*continued*  
 pleuro-pneumonia, protective inoculation, 503  
 pustular stomatitis, 624  
 quarter-evil, 590, 593  
   protective inoculation, 592  
 rabies, 619  
   legislation, 622  
 restrictions on movements, 478  
 scabies in sheep, 516  
   legislation, 527  
 sheep-pox, 470, 514  
   legislation, 515  
 South African horse sickness, 611  
   protective inoculation, 614  
 swine erysipelas, 551  
   fever, 474, 535  
   legislation, 544  
   plague, 552  
 tetanus, 624  
 tuberculosis, 573  
   control of, 577  
   legislation, 582  
   weak points in the Act, 475  
 Statistical inquiry, 1000  
   accurate collection, 1001  
   admission rate, 1006  
   average duration of each case, 1006  
   average inefficiency, 1007  
   averages, 1004  
   births, 1009  
   Board of Agriculture, 1008  
   castings, 1010  
   expression of results, 1007  
   extreme values, 1004  
   graphic expressions, 1007  
   group building, 1002  
   influence of season, 1010  
   methods, 1004  
   mortality, 1009  
   normal duration of life, 1009  
   sick population, 1006  
   sufficient number of facts, 1003  
 Statistics of condemnation (flesh), 676  
   of percolation, 3  
   vital, of cavalry horses, 45  
 Steaming apparatus, 270  
 Stells, 855  
*Stik-gras* of the Boers, 193  
*Stipa viridula* var. *robusta*, 187  
 Stomach digestion, rate of, 141  
   of horse, size of, 139  
*Stomoxys calcitrans*, 431  
 Storage of water, 12  
 Strangles, 600  
 Straw, 233  
   analysis, 235  
 Straw-yard, 344  
 Stramonium, 181

- Streptococcus*, 450  
   *agaluctia*, 451  
   *equi*, 451  
*Streptothrices*, 452  
*Streptothrix bovis*, 452  
   *farcinica*, 452  
   *necrophora*, 452  
**Strongles**, 416  
*Strongylus armatus*, 442  
   *cervicornis*, 441  
   *contortus*, 441  
   *convolutus*, 441  
   *filaria*, 439  
   *gracilis*, 441  
   *micrurus*, 439  
   *rufescens*, 439  
   *tetracanthus*, 441  
**Stumbling** (horse), 780  
**Subcutaneous mastitis**, 692  
 'Substance sensibilisatrice' of Bordet, 459  
**Substitutional dieting**, 120  
   equivalents for, 120  
**Suctoria**, 447  
**Sugar in pig feeding**, 133  
**Sulphur and lime dip**, 520  
**Sulphuretted hydrogen in stable air**, 89  
**Sulphuric acid in water**, 18  
**Sulphurous acid**, 36, 402  
**Surface draining**, 359  
   of cow-sheds, 366  
**Surface-water in wells**, 8  
**Surra**, 609, 999  
**Suspended matter in the air**, 34  
**Swedes**, 262  
**Sweet vernal**, 209  
**Swine, ball-feeding of**, 865  
   boars, 867  
   erysipelas, 551  
   immunization, 552  
     Lorenz's method, 552  
   excreta, amount of, 357  
   farrowing, 866  
   fattening, 864  
   feeding, 132, 863  
   fever, 28, 474, 481, 535  
     disinfection after, 398  
     disinfectant, 542  
     infection, 539  
     legislation, 544  
   foot and mouth disease, 507  
   management of pigs, 862  
   mortality, 1011  
   Pasteurelloses, 599  
   piggeries, 345, 866  
   plague, 552, 599  
   pneumonia, contagious, 599  
   septicæmia, 599  
   statistics, 1011  
   Swine weaning, 864  
   *Symbiotes*, 424  
     *auris canis*, 874  
   Symbiotic mange, 531  
*Tabanidae*, 425  
*Tabanus bovinus*, 426  
**Tables, analysis of bran**, 244  
   of green grasses, 230  
   of Indian pulses, 250  
   of maize, 241  
   of linseed, 252  
   of peas, 249  
   of roots, 264  
   of oats, 240  
   of straws, 235  
   average percentage composition  
     of pasture grasses, 207  
   composition, barley and pro-  
     ducts, 247  
   composition of cakes, 255  
   digestibility, barley and pro-  
     ducts, 247  
     cakes, 259  
     peas, 249  
   for calculating diets, 148  
*Tænia cœnurus*, 436, 676  
*echinococcus*, 436, 676  
*expansa*, 436  
*marginata*, 436, 676  
*mediocanellata*, 436  
*saginata*, 674  
*serialis*, 436  
*serrata*, 436  
*solum*, 436, 674  
**Tall fescue**, 212  
**Tame syringa**, 193  
**Tank, dipping, for cattle**, 422  
**Tares**, 227  
**Tartaric acid**, 100  
**Tattooing army numbers**, 991  
**Taxine**, 191  
*Taxus baccata*, 191  
**Telegony**, 897  
**Teleutospore**, 164  
**Temperature of stable air**, 89  
**Temuline**, 186  
*Tenebrio farina*, 168  
   *mollitor*, 168  
**Testing drains and traps**, 380  
**Tetanus**, 392, 624  
**Texas fever**, 156, 417, 421, 422, 604, 605  
**Theodosian code**, 963  
**Thermometric test of stable-air im-  
 purities**, 64  
**Thousand-headed kale**, 263  
 'Thrush,' 744  
**Tick bites**, 605  
   black-pitted, 417

- 'Tick fever,' 604  
 Ticks, 417  
 'Til' cake, 256  
*Tilletia caries*, 162  
 Time needed for feeding, 144  
 Timothy, 216  
 Tobacco, 181  
 Tobin's air-tubes, 76  
 Toxins, 456  
 Toxophore, 457  
 Transport, ambulance, 931  
   care after landing, 921  
   cattle by rail, 929  
   clipping, 916  
   diseases, 917  
   drainage, 914  
   Edmonds' system of steam injection, 902  
   exercise, 913  
   feeding, 916  
   fittings on ships, 904  
   gangways, 912  
   Green's system, 903  
   grooming at sea, 916  
   hay-nets, 911  
   hospitals, 912  
   laminitis, 918  
   legislation, 922, 929, 932  
   mangers, 910  
   mortality, 918  
   mule stalls, 910  
   pneumonia, 917  
   rail, by, 927  
   road, by, 931  
   ship-staggers, 918  
   slings, 911  
   treatment before embarking, 920  
   ventilation, 900  
   vessel, selection of, 899  
   veterinary duties on board, 921  
   windsails, 901  
   wind-scoops, 902  
   water, 915  
 Trap, bell, 373  
   'D,' 373  
   dip, 373  
   gully, 374  
 Traps, drainage, 371  
 Traumatic mastitis, 692  
 Trefoil, 226  
   birdsfoot, 227  
*Trematodes*, 437  
*Trichinosis*, 674  
*Trichodectes*, 434  
   *cucumerina*, 435  
*Trichophyton tonsurans*, 444, 452  
*Trifolium hybridum*, 226  
   *incarnatum*, 226  
   *minus*, 226  
   *vratense*, 225  
*Trifolium repens*, 225  
 'Tristeza' disease of the Argentine, 417  
*Trombidium*, 168  
*Trypanosoma Brucei*, 432, 447  
   *equinum*, 447  
   *equiperdum*, 447  
   *Evansi*, 447  
   *Lewisi*, 435  
   *Theileri*, 447  
 Trypanosomata, 609  
 Tse-tse, 431, 447, 609, 999  
 Tubercular disease of the udder of cows, 481, 688  
   lesions, classification of, 673  
 Tuberculin testing, 578  
 Tuberculosis, 573  
   immunizing against, 581  
   of the udder, 481, 688  
   Royal Commission on, 696  
 Tuberculous meat, destruction of, 672  
 'Tucked-up' horse, 143, 155  
 Tulp, 184, 187  
 Turnips, 262  
 Tying arrangements for horses, 302  
*Tyroglyphus*, 168  
 Tyrosin, 95  
  
*Umbelliferae*, 172  
 Underground drains, 366  
 Underlocking of ewes, 860  
 Upright buttercup, 181  
 Urea, 95  
*Uredo linearis*, 164  
 Uredospores, 164  
*Ustilago carbo*, 163  
 Utilization and destruction of condemned meat, 679  
  
 Vaccination, calves, 644  
   lymph, collection of, 644  
   glycerinated, 645  
   preparation, 644  
   treatment after collection, 645  
 Vaccine lymph, 643  
 Vaccinia, 694  
 Varicella, 694  
 Various articles of food, 198  
 Veda (Peru), 995  
 Vegetable acids, 100  
   matter in lakes, 6  
   parasites, 162, 443  
 Ventilation, 53  
   artificial, 65  
   board ship, 900  
   Boyle's system, 65  
   methods of, 62  
   methods of examining sufficiency of, 84

- Veterinary department of Board of  
Agriculture, 468  
Vetch, kidney, 229  
*Vibrio tritici*, 168  
*Vicia sativa*, 227  
Vices of working horses, 793  
Vitiation of air by combustion, 35  
Vitrified paving-brick, 282
- Walnut, 184  
Walls, inside, 280  
War. *See* Military Hygiene  
Warble cell, 428  
fly, 415, 428  
Warming stables, 67  
'Washy' horses, 145  
Water, 1  
analyses, 26  
ammonia in, 20  
bacteriological examination of,  
16  
chemical analysis of, 13  
chlorine in, 18  
Clark's process, 13  
classification of, 8  
collection of, 5  
copper in, 22  
dropwort, 176, 177  
examination of, 13  
filtration of, 12  
hardness of, 10, 17  
hemlock, American, 176  
inferences from qualitative tests,  
22  
impure, diseases produced by,  
28  
impurities found in, 9  
iron in, 22  
lead in, 22  
lime in, 17  
microscopical examination of, 15  
magnesia in, 18  
nitric acid in, 19  
nitrous acid in, 19  
oxydizable matter in, 21  
physical examination of, 14-15  
phosphoric acid in, 21, 23
- Water—*continued*  
plants, purifying action of, 6  
purification of, 12  
qualitative examination of, 16  
quantity required, 27  
reaction of, 17  
river, 6  
sources of, 3  
storage of, 12  
sulphuric acid in, 18  
troughs, disinfection of, 409  
Watery vapour in stable air, 89  
the air, 34  
Watson's cattle-feeding mixture, 129  
Weaning of calves, 126  
'Weaving' (horses), 751  
Weevil, 169  
Weight, weekly increase, cattle, 126  
Weights and measures, 1014  
Well, area drained by, 8  
Wells, artesian, 7  
deep and shallow, 7  
Wheat, 212  
for horses, 157  
Wheels, height and width of, 829  
Whipple-trees, equalizing, 829  
White scour, 51, 394, 595, 833  
skit, 858  
Wind-sucking, 143, 750  
Woburn experiment in feeding, 129  
Wool, feeding sheep for, 132  
Wool-sorters' disease, 196. *See* An-  
thrax  
Work of horses, 116, 773  
producing power of food, 111  
Worms, 435
- Yard feeding of cattle, 128  
straw, 344  
Yards, covered and open, 344  
Yeasts, 453  
Yellow oat-grass, 216  
Yew poisoning, 191  
tree, 191
- Zinc chloride, 404  
*Zygodenus venosus*, 183



**CATALOGUE OF**  
**William R. Jenkins Co.'s**  
 Works Concerning  
**HORSES, CATTLE, SHEEP, SWINE, Etc.**  
**1910**

(\*) *Designates New Books.*

(†) *Designates Recent Publications.*

- ANDERSON.** "Vice in the Horse" and other papers on Horses and Riding. By E. L. Anderson. Size, 6 x 9, cloth, illustrated.....1 75
- ARMSTEAD.** "The Artistic Anatomy of the Horse." A brief description of the various Anatomical Structures which may be distinguished during Life through the Skin. By Hugh W. Armstead, M.D., F.R.C.S. With illustrations from drawings by the author. Cloth oblong, 10 x 12½.....3 75
- BACH.** "How to Judge a Horse." A concise treatise as to its Qualities and Soundness; Including Bits and Biting, Saddles and Saddling, Stable Drainage, Driving One Horse, a Pair, Four-in-hand, or Tandem, etc. By Capt. F.W. Bach. Size, 5 x 7½, clo., fully illus.1 00
- BANHAM.** "Tables of Veterinary Posology and Therapeutics," with weights, measures, etc. By Geo. A. Banham, F. R. C. V. S. New edition. Cloth, size 4 x 5 1-2, 192 pages.....1 00
- BAUCHER.** "Method of Horsemanship." Including the Breaking and Training of Horses. By F. Baucher. (Temporarily out of print).
- BELL.** (\*) "The Veterinarian's Call Book (Perpetual)," By Roscoe R. Bell, D.V.S., editor of the *American Veterinary Review*. Completely revised.  
 A visiting list, that can be commenced at any time and used until full, containing much useful information for the student and the busy practitioner. Among contents are items concerning: Prescription writing; Veterinary Drugs; Poisons; Solubility of Drugs; Composition of Milk, Bile, Blood, Gastric Juice, Urine, Saliva; Respiration; Dentition; Temperature, etc., etc. Bound in flexible leather, with flap and pocket..... 1 25

**BITTING.** "Cadiot's Exercises in Equine Surgery."

See "Cadiot."

**BRADLEY.** "Outlines of Veterinary Anatomy."

By O. Charnock Bradley, Member of the Royal College of Veterinary Surgeons; Professor of Anatomy in the New Veterinary College, Edinburgh.

The author presents the most important facts of veterinary anatomy in as condensed a form as possible, consistent with lucidity. 12mo.

Complete in three parts.

PART I.: *The Limbs* (cloth).....1 25

PART II.: *The Trunk* (paper) .....1 25

PART III.: *The Head and Neck* (paper).....1 25

THE SET COMPLETE .....3 25

**CADIOT.** "Exercises in Equine Surgery." By P. J.

Cadiot. Translated by Prof. A. W. Bitting, D.V.M.

Edited by Prof. A. Liautard, M.D.V.M. Size, 6 x 9¼. cloth, illustrated..... 2 50

— "Roaring in Horses." Its Pathology and Treatment.

This work represents the latest development in operative methods for the alleviation of roaring. Each step is most clearly defined by excellent full-page illustrations. By P. J. Cadiot, Professor at the Veterinary School, Alfort. Translated by Thos. J. Watt Dollar, M.R.C.V.S., etc. Cloth, size 5 1-4 x 7 1-8, 77 pages, illustrated..... 75

— "Studies in Clinical Veterinary Medicine and Surgery."

By P. J. Cadiot. Translated, edited, and supplemented with 49 new articles and 34 illustrations by Jno. A. W. Dollar, M.R.C.V.S. Cloth, size 7 x 9 3-4, 619 pages, 94 black and white illustrations..... 5 25

— (\*) "A Treatise on Surgical Therapeutics of the Domestic Animals." By P. J. Cadiot and J. Almy. Translated by Prof. A. Liautard, M.D., V.M.

General Surgery.—Means of restraint of animals, general anæsthesia, local anæsthesia, surgical anti-sepsis and asepsis, hematosiis, cauterization, firing, Diseases Common to all Tissues.—Inflammation, abscess, gangrene, ulcers, fistula, foreign bodies, traumatic lesions, complications of traumatic lesions, granulations, cicatrices, mycosis, virulent diseases, tumors.

Diseases Special to all Tissues and Affections of the Extremities.—Diseases of skin and cellular tissue, of serous bursae, of muscles, of tendons, of tendinous synovial sacs, of aponeurosis, of arteries, of veins, of lymphatics, of nerves, of bones, of articulations.

Cloth, size 6 x 9, 580 pages, 118 illustrations.... 4 50

**CAMPBELL and LECROIX.** (\*) "Essentials of Parasitology," with a brief discourse on ZOOLOGY. Size 5 3-4 x 8 1-2, 96 pages, with three Charts.....1 00



- CHAPMAN.** "Manual of the Pathological Treatment of Lameness in the Horse," treated solely by mechanical means. By George T. Chapman. Cloth, size 6 x 9, 124 pages with portrait..... 2 00
- CLARKE.** "Chart of the Feet and Teeth of Fossil Horses." By W. H. Clarke. Card, size 9 1-2 x 12.. 25
- "Horses' Teeth." Fourth edition, re-revised, with second appendix. Cloth, size 5 1-4 x 7 1-2, 322 pp., illus.. 2 50
- CLEVELAND.** "Pronouncing Medical Lexicon." Pocket edition. By C. H. Cleveland, M.D. Cloth, size 3 1-4 x 4 1-2, 302 pages..... 75
- CLEMENT.** "Veterinary Post Mortem Examinations." By A. W. Clement, V.S. The absence in the English language of any guide in making autopsies upon the lower animals, induced Dr. Clement to write this book, trusting that it would prove of practical value to the profession. Cloth, size 5 x 7 1-2, 64 pages, illustrated..... 75
- COURTENAY.** (†) "Manual of the Practice of Veterinary Medicine." By Edward Courtenay, V. S. Revised by Frederick T. G. Hobday, F.R.C.V.S. Second edition. Cloth, size 5 1-4 x 7 1-2, 573 pages ..... 2 75
- COX.** "Horses: In Accident and Disease." The sketches introduced embrace various attitudes which have been observed, such as in choking; the disorders and accidents occurring to the stomach and intestines; affection of the brain; and some special forms of lameness, etc. By J. Roalfe Cox, F.R.C.V.S. Cloth, size 6 x 9, 28 full page illustrations..... 1 50
- DALRYMPLE.** (\*) "Veterinary Obstetrics." A compendium for the use of advanced students and Practitioners. By W. H. Dalrymple, M. R. C. V. S., principal of the Department of Veterinary Science in the Louisiana State University and A. & M. College; Veterinarian to the Louisiana State Bureau of Agriculture, and Agricultural Experiment Stations. Second edition revised. Cloth, size 6x9 1-4, 162 pages, 51 illustrations..... 2 50
- DALZIEL.** "Breaking and Training Dogs." Part I, by Pathfinder. Part II, by Hugh Dalziel. Cloth, illustrated..... 2 50
- "The Collie." By Hugh Dalziel. Paper, illustrated.... 50
- "The Diseases of Dogs." Causes, symptoms and treatment. By Hugh Dalziel. Illustrated. Paper..... 50
- "The Fox Terrier." By Hugh Dalziel. Paper, 50; clo. 1 00
- "The Greyhound." Cloth, illus..... 1 00
- "The St. Bernard." Cloth, illustrated..... 1 00

**DANCE.** "Veterinary Tablet." By A. A. Dance. Chart, 17 x 24, mounted on linen, folded in a cloth case for the pocket, size 3 3-4 x 6 1-2. Shows at a glance the synopsis of the diseases of horses, cattle and dogs; with their cause, symptoms and cure..... 75-

**DE BRUIN.** (\*)"Bovine Obstetrics." By M. G. De Bruin Instructor of Obstetrics at the State Veterinary School in Utrecht. Translated by W. E. A. Wyman, formerly Professor of Veterinary Science at Clemson A. & M. College, and Veterinarian to the South Carolina Experiment Station. Cloth, size 6 x 9, 382 pages, 77 illustrations..... 5 00

**Synopsis of the Essential Features of the Work**

1. Authorized translation.
2. The only obstetrical work which is up to date.
3. Written by Europe's leading authority on the subject.
4. Written by a man who has practiced the art a lifetime.
5. Written by a man who, on account of his eminence as bovine practitioner and teacher of obstetrics, was selected by Prof. Dr. Fröhner and Prof. Dr. Bayer (Berlin and Vienna), to discuss bovine obstetrics both practically and scientifically.
6. The only work containing a thorough differential diagnosis of ante and post partum diseases.
7. The only work doing justice to modern obstetrical surgery and therapeutics.
8. Written by a man whose practical suggestions revolutionized the teaching of veterinary obstetrics even in the great schools of Europe.
9. The only work dealing fully with the now no longer-obscure contagious and infectious diseases of calves.
10. Absolutely original and no compilation.
11. The only work dealing fully with the difficult problem of teaching obstetrics in the colleges.
12. The only work where the practical part is not overshadowed by theory.

... A veterinarian, particularly if his location brings him in contact with obstetrical practice, who makes any pretence toward being scientific and in possession of modern knowledge upon this subject, will not be without this excellent work, as it is really a very valuable treatise.—Prof. Roscoe R. Bell, in the *American Veterinary Review*.

In translating into English Professor De Bruin's excellent textbook on Bovine Obstetrics, Dr. Wyman has laid British and American veterinary surgeons and students under a debt of gratitude. The work represents the happy medium between the booklets which are adapted for cramming purposes by the student, and the ponderous tomes which, although useful to the teacher, are not exactly suited to the requirements of the everyday practitioner . . . We can strongly recommend the work to veterinary students and practitioners.—*The Journal of Comparative Pathology and Therapeutics*.

**DOLLAR.** (\*)"Diseases of Cattle, Sheep, Goats and Swine." By G. Moussu and Jno. A. W. Dollar, M.R.C.V.S. Size 6 x 9 1-2, 785 pages, 329 illustrations in the text and 4 full page plates..... 8 75-

— (†)"A. Hand-book of Horse-Shoeing," with introductory chapters on the anatomy and physiology of the horse's foot. By Jno. A. W. Dollar, M.R.C.V.S., with the collaboration of Albert Wheatley, F.R.C.V.S. Cloth, size 6 x 8 1-2, 433 pages, 406 illustrations . . 4 75-

**DOLLAR** (continued)

- (†) **“Operative Technique.”** Volume 1 of “The Practice of Veterinary Surgery.” Cloth, size 6 3-4 x 10, 264 pages, 272 illustrations. . . . . 3 75
- **“General Surgery.”** Volume 2 of “The Practice of Veterinary Surgery.” In preparation.
- (†) **“Regional Veterinary Surgery.”** Volume 3 of “The Practice of Veterinary Surgery.” By Drs. Jno. A. W. Dollar and H. Möller. Cloth, size 6 1-2 x 10 853 and xvi pages, 315 illustrations. . . . . 6 25
- **“Cadiot’s Clinical Veterinary Medicine and Surgery.”**  
*See “Cadiot.”*
- **“Cadiot’s Roaring in Horses.”** *See “Cadiot.”*

**DUN.** (\*) **“Veterinary Medicines, their Actions and Uses.”**  
By Finlay Dun, V.S., late lecturer on Materia Medica and Dietetics at the Edinburgh Veterinary College, and Examiner in Chemistry to the Royal College of Veterinary Surgeons. Edited by James Macqueen, F.R.C.V.S., and Harold A. Woodruff, M.R.C.V.S. Twelfth English edition. Cloth, size 6 x 9. . . . . 3 75

- FLEMING.** **“The Contagious Diseases of Animals.”** Their influence on the wealth and health of nations and how they are to be combated. Paper, size 5 x 7 1-2, 30 pages. . . . . 25
- **“Parasites and Parasitic Diseases of the Domesticated Animals.”** *See “Neumann.”*
  - **“Operative Veterinary Surgery.”** Vol. I, by Dr. Geo. Fleming, M.R.C.V.S. This valuable work, one of the most practical treatises yet issued on the subject in the English language, is devoted to the common operations of Veterinary Surgery; and the concise descriptions and directions of the text are illustrated with numerous wood engravings. Cloth, size 6 x 9 1-4, 285 and xviii pages, 343 illustrations. . . . . 2 75  
(\*) Vol. II, edited and passed through the press by W. Owen Williams, F.R.C.V.S. Cloth, size 6 x 9 1-4, 430 and xxxvii pages, 344 illustrations. . . . . 3 25
  - **“Roaring in Horses.”** By Dr. George Fleming, F.R.C.V.S. Its history, nature, causes, prevention and treatment. Cloth, size 5 1-2 x 8 3-4, 160 pages, 21 engravings, 1 colored plate. . . . . 1 50
  - **“Veterinary Obstetrics.”** Including the Accidents and Diseases incident to Pregnancy, Parturition, and the Early Age in Domesticated Animals. By Geo. Fleming, F.R.C.V.S. Cloth, size 6 x 8 3-4, 758 pages, illus. 6 25

- GOTTHEL.** (†) **“A Manual of General Histology.”**  
 By Wm. S. Gotthel, M.D., Professor of Pathology in the American Veterinary College, New York; etc., etc.  
 Histology is the basis of the physician's art, as Anatomy is the foundation of the surgeon's science. The subject is presented in an accessible and simple form. Second edition revised. Cloth, size 5 1-2 x 8, 152 pages, 68 illustrations..... 1 00
- GRESSWELL.** **“Diseases and Disorders of the Horse.”**  
 A Treatise on Equine Medicine and Surgery, being a contribution to the science of comparative pathology. By Albert, Jas. B. and Geo. Gresswell. Cloth, size 5 3-4 x 8 3-4, 227 pages, illustrated.... 1 75
- **“The Bovine Prescriber.”** For the use of Veterinarians and Veterinary Students. Second edition, revised and enlarged, by James B. and Albert Gresswell, M.R.C.V.S. Cloth, size, 5 x 7 1-2, 102 pages..... 75
- **“The Equine Hospital Prescriber.”** For the use of Veterinary Practitioners and Students. Third edition revised and enlarged, by Drs. James B. and Albert Gresswell, M.R.C.V.S. Cloth, size 5 x 7 1-2, 165 pages..... 75
- **Manual of “The Theory and Practice of Equine Medicine.”**  
 By James B. Gresswell, F.R.C.V.S., and Albert Gresswell, M.R.C.V.S. Second edition revised. Cloth, size 5 1-4 x 7 1-2, 539 pages..... 2 75
- (†) **“Veterinary Pharmacopœia and Manual of Comparative Therapy.”** By George and Charles Gresswell, with descriptions and physiological actions of medicines, by Albert Gresswell. Second edition revised and enlarged. Cloth, 6 x 8 3-4, 457 pages..... 3 50
- HASSLOCH.** **“A Compend of Veterinary Materia Medica and Therapeutics.”** By A. C. Hassloch, V.S., Lecturer on Materia Medica and Therapeutics, and Professor of Veterinary Dentistry at the New York College of Veterinary Surgeons and School of Comparative Medicine, N. Y. Cloth, size 5 1-4 x 7 1-2, 225 pages..... 1 50
- HEATLEY.** **“The Stock Owner's Guide.”** A handy Medical Treatise for every man who owns an ox or cow. By George S. Heatley, M.R.C.V.S. Cloth, size 5 1-4 x 8, 172 pages..... 1 25
- HILL.** (†) **“The Diseases of the Cat.”** By J. Woodroffe Hill, F.R.C.V.S. Cloth, size 5 1-4 x 7 1-2, 123 pages, illustrated..... 1 25  
 Written from the experience of many years' practice and close pathological research.
- **“The Management and Diseases of the Dog.”** By J. Woodroffe Hill, F.R.C.V.S. Cloth, size 5 x 7 1-2, extra fully illustrated.

**HINEBAUCH.** "Veterinary Dental Surgery." By T. D. Hinebauch, M.S.V.S. For the use of Students, Practitioners and Stockmen. Cloth, size 5 1-4 x 8, 256 pages, illustrated.

**HOARE.** (\*) "A Manual of Veterinary Therapeutics and Pharmacology." By E. Wallis Hoare, F.R.C.V.S. Cloth, size 5 1-4 x 7 1-4, xxvi plus 786 pages..... 4 75

**HOBDAY.** (†) "The Castration of Cryptorchid Horses and the Ovariotomy of Troublesome Mares." By Frederick T. G. Hobday, F.R.C.V.S. Cloth, size 5 3-4 x 8 3-4, 106 pages, 34 illustrations..... 1 75

**HUNTING.** (†) The Art of Horse-shoeing. A manual for Horseshoers. By William Hunting, F.R.C.V.S., ex-President of the Royal College of Veterinary Surgeons. One of the most up-to-date, concise books of its kind in the English language. Cloth, size 6 x 9 1-4. 126 pages, 96 illustrations..... 1 00

**JENKINS.** (\*) "Anatomical and Physiological Model of the Cow." Half life size. Composed of superposed plates, colored to nature, showing internal organs, muscles, skeleton, etc., mounted on strong boards, with explanatory text. Size of Model opened, 10 ft. x 3 ft., closed 3 ft. x 1½ ft..... 10 00

— "Anatomical and Physiological Model of the Horse." Half life size. Size of Model 38 x 41 in..... 12 00

— Anatomical and Physiological Models. Colored to Nature, With explanatory Charts. Opened, 22in. x 26 1-2 in.; closed, 11 in. x 26 1-2 in.

Horse, 384 parts.....	2 00
Cow, 393 parts.....	2 00
Sheep, 364 parts.....	2 00
Dog, 364 parts.....	2 00
Fig, in preparation.	

All five models ordered at one time, prepaid..... 8 75

With each model and chart a descriptive book of the animal is supplied free. These books when sold separately are 25c. each.

These models are not only of the utmost value to veterinarians, but every lecturer, student, owner of a dairy, will be amazed at the resultant value and convenience to him of a thing of the sort hanging for ready reference on the wall of his room or office. For clearness the model at once surpasses books and atlases.

**JONES.** (\*) "The Surgical Anatomy of the Horse." By Jno. T. Share Jones, M.R.C.V.S. Parts I, II and III ready. To be completed in four parts. Each part—paper, \$4.25; cloth, \$5.00.

**JORDAN.** (\*) "The Gait of the American Trotter and Pacer." By Rudolf Jordan, Jr. Size 6 1-4 x 9 1-2, xii plus 324 pages, 217 illustrations, including 11 full page, and frontispiece in color.....3 50

Every lover of the harness horse should read this book. The most notable study of the trotting and pacing gaits ever published. It clears up the question of balance by a simple inquiry into cause and effect. It gives an exact analysis of the motion, action and extension of the two gaits, and with numerous illustrations points the way to the proper adjustment of hoof and shoe for a square gait. It sets forth many important facts by a new and practical method of fixing the origin of a faulty gait. Its investigations for the rational development of speed by means of a corrected gait make it a valuable aid to every owner and trainer.

A Classic.—*Chicago Horseman.*

**KOBERT.** "Practical Toxicology for Physicians and Students" By Professor Dr. Rudolph Kobert, Medical Director of Dr. Brehmer's Sanitarium for Pulmonary Diseases at Goerbersderf in Silesia (Prussia), late Director of the Pharmacological Institute, Dorpat, Russia. Translated and edited by L. H. Friedburg, Ph.D. Authorized Edition. Practical knowledge by means of tables which occupy little space, but show at a glance similarities and differences between poisons of the same group. Also rules for the Spelling and Pronunciation of Chemical Terms, as adopted by the American Association for the Advancement of Science. Cloth, 6 1-2 x 10, 201 pp..2 50

**KOCH.** "Etiology of Tuberculosis." By Dr. R. Koch. Translated by T. Saure. Cloth, size 6 x 9 1-4, 97 pages.....1 00

**LAW.** "Farmers' Veterinary Adviser." A Guide to the Prevention and Treatment of Disease in Domestic Animals. By Prof. James Law. Cloth, size 5 1-4 x 7 1-2, illustrated.....3 00

**LIAUTARD.** (†) "Animal Castration." A concise and practical Treatise on the Castration of the Domestic Animals. The only work on the subject in the English language. By Alexander Liautard, M.D., V.S. Having a fine portrait of the author. Tenth edition revised and enlarged. Cloth, size 5 1-4 x 7 1-2, 165 pages, 45 illustrations.....2 00

..... The most complete and comprehensive work on the subject in English veterinary literature.—*American Agriculturist.*

**LIAUTARD** (continued).

- “**Cadiot’s Exercises in Equine Surgery.**” Translated by Prof. Bitting and edited by Dr. Liautard.  
See “*Cadiot.*”
- “**A Treatise on Surgical Therapeutics of the Domestic Animals.**” By Prof. Dr. P. J. Cadiot and J. Almy. Translated by Prof. Liautard. See “*Cadiot.*”
- “**How to Tell the Age of the Domestic Animal.**” By Dr. A. Liautard, M.D., V.S. Standard work upon this subject, concise, helpful and containing many illustrations. Cloth, size 5 x 7 1-2, 35 pages, 42 illustrations..... 50
- “**Lameness of Horses and Diseases of the Locomotory Apparatus.**” By A. Liautard, M.D., V.S. This work is the result of Dr. Liautard’s many years of experience. Cloth, size 5 1-4 x 7 1-2, 314 pages..... 2 50
- (\*) “**Manual of Operative Veterinary Surgery.**” By A. Liautard, M.D., V.M. Engaged for years in the work of teaching this special department of veterinary medicine, and having abundant opportunities of realizing the difficulties which the student who earnestly strives to perfect himself in his calling is obliged to encounter, the author formed the determination to facilitate his acquisition of knowledge, and began the accumulation of material by the compilation of data and arrangement of memorandum, with the recorded notes of his own experience, the fruit of a long and extended practice and a careful study of the various authorities who have illustrated and organized veterinary literature. Revised edition, with complete index. Cloth, size 6 1-4 x 9, xxx and 803 pages, 563 illustrations..... 5 00
- “**Pellerin’s Median Neurotomy in the Treatment of Chronic Tendinitis and Periostosis of the Fetlock.**” Translated by Dr. A. Liautard. See “*Pellerin.*”
- “**Vade Mecum of Equine Anatomy.**” By A. Liautard, M.D., V.S. For the use of advanced students and veterinary surgeons. Third edition. Cloth, size 5 x 7 1-2, 30 pages and 10 full page illustrations of the arteries. .... 2 00
- Zundel’s “**The Horse’s Foot and Its Diseases.**”  
See “*Zundel.*”
- LONG.** “**Book of the Pig.**” Its selection, Breeding, Feeding and Management. Cloth..... 4.00

**LOWE.** (†) "**Breeding Racehorses by the Figure System.**" Compiled by the late C. Bruce Lowe. Edited by William Allison, "The Special Commissioner," *London Sportsman*, Hon. Secretary Sporting League, and Manager of the International Horse Agency and Exchange. With numerous fine illustrations of celebrated horses. Cloth, size 8 x 10, 262 pages..... 7 50

**LUDLOW.** "Science in the Stable"; or How a Horse can be Kept in Perfect Health and be Used Without Shoes, in Harness or under the Saddle. With the Reason Why. Second Edition. By Jacob R. Ludlow, M.D. Late Staff Surgeon, U. S. Army. Paper, size 4 1-2 x 5 3-4, 166 pages..... 50

**LUPTON.** "Horses: Sound and Unsound," with Law relating to Sales and Warranty. By J. Irvine Lupton, F.R.C.V.S. Cloth, size 5 3-4 x 7 1-2, 217 pages, 28 illustrations..... 1 25

**M'FADYEAN.** (†) "**Anatomy of the Horse.**" Second edition completely revised. A Dissection Guide. By John M'Fadyean, M.B., B.Sc., F.R.S.E. Cloth, size 6 x 8 3 4, 388 pages, illustrated..... 6 50

This book is intended for Veterinary students, and offers to them in its 48 full-page colored plates, 54 illustrations and excellent text, a valuable and practical aid in the study of Veterinary Anatomy, especially in the dissecting room.

— "**Comparative Anatomy of the Domesticated Animals.**" By J. M'Fadyean. Profusely illustrated, and to be issued in two parts.

Part I—Osteology, ready. Size 5 1-2 x 8 1-2, 166 pages, 132 illustrations. Paper, 2 50; cloth..... 2 75  
(Part II in preparation.)

**MAGNER.** "**Standard Horse and Stock Book.**" By D. Magner. Comprising over 1,000 pages, illustrated with 1756 engravings. Leather binding..... 6 00

**MILLS.** "**How to Keep a Dog in the City.**" By Wesley Mills, M.D., D.V.S. It tells how to choose, manage, house, feed, educate the pup, how to keep him clean and teach him cleanliness. Paper, size 5 x 7 1-2, 40 pages..... 25

**MOHLER.** "**Handbook of Meat Inspection.**" By Robert Ostertag, M.D. Translated by Earley Vernon Wilcox, A.M., Ph.D. With an introduction by John R. Mohler, V.M.D., A.M. See "*Ostertag.*"

**MÖLLER — DOLLAR.** (†) "**Regional Veterinary Surgery.**" See "*Dollar.*"



**MOSSELMAN-LIENAU.** "Manual of Veterinary Microbiology." By Professors Mosselman and Liénaux, Nat. Veterinary College, Cureghem, Belgium. Translated and edited by R. R. Dinwiddie, Professor of Veterinary Science, College of Agriculture, Arkansas State University. Cloth, size 6 1 2 x 8, 342 pages, illustrated.....2 00

**MOUSSU.** (\*) "Diseases of Cattle, Sheep, Goats and Swine." See "Dollar."

**NEUMANN.** (\*) "A Treatise on Parasites and Parasitic Diseases of the Domesticated Animals." A work to which the students of human or veterinary medicine, the sanitarian, agriculturist or breeder or rearer of animals, may refer for full information regarding the external and internal Parasites—vegetable and animal—which attack various species of Domestic Animals. A Treatise by L. G. Neumann, Professor at the National Veterinary School of Toulouse. Translated and edited by Geo. Fleming, C.B., LL.D., F.R.C.V.S. Second edition, revised and edited by James Macqueen, F.R.C.V.S., Professor at the Royal Veterinary College, London. Cloth, size 6 3 4 x 10, xvi + 698 pages, 365 illustrations ..... 6 75

**NOCARD.** "The Animal Tuberculoses, and their Relation to Human Tuberculosis." By Ed. Nocard, Prof. of the Alfort Veterinary College. Translated by H. Scurfield, M.D. Ed., Ph. Camb. Cloth, 5 x 7 1-2, 143 pages..1 00

Perhaps the chief interest to doctors of human medicine in Professor Nocard's book lies in the demonstration of the small part played by heredity, and the great part played by contagion in the propagation of bovine tuberculosis.

**NUNN.** (\*) "Veterinary Toxicology." By Joshua A. Nunn, F.R.C.V.S. The study of toxicology is intimately blended with other biological sciences, particularly physiology and chemistry, both of which it on many occasions overlaps. A carefully arranged and complete index is given in the front of the volume. Cloth, size 6 x 8 3-4, vii + 191 pages.....1 75

**OSTERTAG.** (\*) "Handbook of Meat Inspection." [By Robert Ostertag, M.D. Authorized Translation [by Earley Vernon Wilcox, A.M., Ph.D. With an introduction by John R. Mohler, V.M.D., A.M. The work is exhaustive and authoritative and has at once become the standard authority upon the subject. Second edition, revised. Cloth, size 6 3-4 x 9 3-4, 920 pages, 260 illustrations and 1 colored plate. ....7 50

**PALLIN.** (†) “A Treatise on Epizootic Lymphangitis.” By Capt. W. A. Pallin, F.R.C.V.S. In this work the author has endeavored to combine his own experience with that of other writers and so attempts to give a clear and complete account of a subject about which there is little at present in English veterinary literature. Cloth, size 5 3-4 x 8 1-2, 90 pages, with 17 fine full page illustrations.....1 25

**PEGLER.** “Goat Keeping for Amateurs.” Paper, 5x7½, 77 pages, illustrated..... 50

**PELLERIN.** “Median Neurotomy in the Treatment of Chronic Tendinitis and Periostosis of the Fetlock.” By C. Pellerin, late repetitor of Clinic and Surgery to the Alfort Veterinary School. Translated, with Additional Facts Relating to It, by Prof. A. Liautard, M.D., V.M. Having rendered good results when performed by himself, the author believes the operation, which consists in dividing the cubito-plantar nerve and in excising a portion of the peripheral end, the means of improving the conditions, and consequently the values of many apparently doomed animals. Agriculture in particular will be benefited.

The work is divided into two parts. The first covers the study of Median Neurotomy itself; the second, the exact relations of the facts as observed by the author. Boards, 6 x 9 1-2, 61 pages, illustrated. .1 00

**PETERS.** “A Tuberculous Herd—Test with Tuberculin.” By Austin Peters, M. R. C. V. S., Chief Inspector of Cattle for the New York State Board of Health during the winter of 1892-93. Pamphlet.... 25

**ROBERGE.** “The Foot of the Horse,” or Lameness and all Diseases of the Feet traced to an Unbalanced Foot Bone, prevented or cured by balancing the foot. By David Roberge. Cloth, size 6 x 9 1-4, 308 pages, illustrated..... 5 00

**SESSIONS.** (\*) “Cattle Tuberculosis,” a Practical Guide to the Agriculturist and Inspector. By Harold Sessions, F.R.C.V.S., etc. Second edition. Size 5 x 7 1-4, vi + 120 pages..... 1 00

The subject can be understood by those who have to deal particularly with it, yet who, perhaps, have not had the necessary training to appreciate technical phraseology.

**SEWELL.** “The Examination of Horses as to Soundness and Selection as to Purchase.” By Edward Sewell, M.R.C.V.S. Paper, size 5 1-2 x 8 1-2, 86 pages, illustrated with 8 plates in color..... 1 50

.... It is a great advantage to the business man to know something of the elements of law, and nobody ought either to buy or own a horse who does not know something about the animal. That something this book gives, and gives in a thoroughly excellent way....

**SMITH.** (\*) "A Manual of Veterinary Physiology." By Vet. Capt. F. Smith, C.M.S., M.R.C.V.S., Examiner in Physiology, Royal College of Veterinary Surgeons, author of "A Manual of Veterinary Hygiene." A completely revised and enlarged edition just published. Cloth, 6 x 8 3-4, 720 pp, 102 illust'ns. . . . 4 25

The whole book has been carefully revised and brought up to date. All the important advances of the last few years have been embodied. The chapter on the nervous system has been specially revised by Prof. Sherrington, whose remarkable work on the "spinal dog" has been introduced. A special point is made of the bearing of physiology on pathology, and the utilization of physiology to the better understanding of every-day practice. The book is written by a veterinary surgeon for veterinary practitioners and students, and is the only work in the English language which can claim to be purely veterinary.

— (\*) "Manual of Veterinary Hygiene." Third edition revised. Cloth, size 5 1-4 x 7 1-2, xx + 1036 pages, with 255 illustrations . . . . . 4 75

Recognizing the rapid advance and extended field of the subject since the previous issue, the author has entirely re-written the work and enlarged its scope, which is brought thoroughly up to date. Contains over 500 more pages than the second edition.

**STRANGEWAY.** (\*) "Veterinary Anatomy." Edited by I. Vaughan, F.L.S., M.R.C.V.S. New 13th American edition revised. Cloth, size 6 1-4 x 9 1-2, 625 pages, 224 illus. . . . . 5 00

**SUSSDORF.** "Six Large Colored Wall Diagrams." By Prof. Sussdorf, M.D. (of Göttingen). Text translated by Prof. W. Owen Williams, of the New Veterinary College, Edinburgh. Size, 44 inches by 30 inches.

- |           |                   |
|-----------|-------------------|
| 1.—Horse. | 4.—Ox.            |
| 2.—Mare.  | 5.—Bear and Sow.  |
| 3.—Cow.   | 6.—Dog and Bitch. |

The above are printed in eight or nine colors. Showing the position of the viscera in the large cavities of the body.

Price, unmounted. . . . . 1 75 each  
 " mounted on linen, with roller. . . . . 3 50 "

**VAN MATER.** "A Text Book of Veterinary Ophthalmology." By George G. Van Mater, M.D., D.V.S., Professor of Ophthalmology in the American Veterinary College; Oculist and Aurist to St. Martha's Sanitarium and Dispensary; Consulting Eye and Ear Surgeon to the Twenty-sixth Ward Dispensary; Eye and Ear Surgeon, Brooklyn Eastern District Dispensary, etc. Illustrated by one chromo lithograph plate and 71 engravings. Cloth, 6 x 9 1-4, 151 pages. . . 3 00

- VETERINARY DIAGRAMS** in Tabular Form.  
 Size, 28½ in. x 22 inches. Price per set of five.... 4 00  
 Mounted and folded in case.....7 00  
 Mounted on roller and varnished.....10 00
- No. 1. "The External Form and Elementary Anatomy of the Horse."** Eight colored illustrations—  
 1. External regions; 2. Skeleton; 3. Muscles (Superior Layer); 4. Muscles (Deep Layer); 5. Respiratory Apparatus; 6. Digestive Apparatus; 7. Circulatory Apparatus; 8. Nerve Apparatus; with description.... 1 25  
 Mounted on roller and varnished..... 2 25
- No. 2. "The Age of Domestic Animals."** Forty-two figures illustrating the structure of the teeth, indicating the Age of the Horse, Ox, Sheep, and Dog, with full description ..... 75  
 Mounted on roller and varnished ..... 2 00
- No. 3. "The Unsoundness and Defects of the Horse."** Fifty figures illustrating—1. The Defects of Conformation; 2. Defects of Position; 3. Infirmities or Signs of Disease; 4. Unsoundnesses; 5. Defects of the Foot; with full description..... 75  
 Mounted on roller and varnished..... 2 00
- No. 4. "The Shoeing of the Horse, Mule and Ox."** Fifty figures descriptive of the Anatomy and Physiology of the Foot and of Horse-shoeing.....75  
 Mounted on roller and varnished..... 2 00
- No. 5. "The Elementary Anatomy, Points, and Butcher's Joints of the Ox."** Ten colored illustrations—1. Skeleton; 2. Nervous System; 3. Digestive System (Right Side); 4. Respiratory System; 5. Points of a Fat Ox; 6. Muscular System; 7. Vascular System; 8. Digestive System (Left Side); 9. Butcher's Sections of a Calf; 10. Butcher's Sections of an Ox; with full description ..... 1 25  
 Mounted on roller and varnished..... 2 25
- WALLEY.** "A Practical Guide to Meat Inspection." By Thomas Walley, M.R.C.V.S., late principal of the Edinburgh Royal (Dick) Veterinary College; Professor of Veterinary Medicine and Surgery, etc. Fourth Edition, thoroughly revised and enlarged by Stewart Stockman, M.R.C.V.S., Professor of Pathology, Lecturer on Hygiene and Meat Inspection at Dick Veterinary College, Edinburgh. Cloth, size 5 1-2 x 8 1-4, with 45 colored illus., 295 pages.... 3 00
- WILCOX.** (\*) "Handbook of Meat Inspection." By Robert Ostertag, M.D. See "Ostertag."
- WILLIAMS.** (\*) "Principles and Practice of Veterinary Medicine." By W. Williams, M.R.C.V.S., revised by his son, W. O. Williams, F.R.C.V.S., F.R.S.E., etc., and S. H. Baldrey, Major I.C.V.D., F.R.C.V.S., D.V.H. (Liv.) Ninth edition. Cloth, 8vo, 1004 pp., 25 colored plates and 88 other illustrations..... 7 50

WILLIAMS (continued)

- “Principles and Practice of Veterinary Surgery.” Author’s edition, entirely revised and illustrated with numerous plain and colored plates. By W. Williams, M.R.C.V.S. Cloth, size 6 1-2 x 9 1-4, 756 pages ..... 7 50

**WINSLOW.** (\*) “The Prevention and Treatment of Diseases of the Domestic Animals,” including Etiology and Symptoms. By Kenelm Winslow, B.A.S., M.D.V., M.D. (Harv.); formerly Instructor in Zoology, Bussey Institute, and Assistant Professor of Therapeutics in the Veterinary School of Harvard University; Fellow of the Massachusetts Medical Society; Surgeon to the Newton Hospital, etc. Cloth, size 6 1-4 x 9 1-2, 302 pages, frontispiece in color ..... 3 50

- (†) “Veterinary Materia Medica and Therapeutics.” By Kenelm Winslow.

**Sixth Edition, Revised and Enlarged**

Cloth, size 6 1-4 x 9 1-4, xii + 859 pages ..... 6 00

The most complete, progressive and scientific book on the subject in the English language. The recognized authority on Veterinary Materia Medica and the standard text-book on the subject in veterinary colleges.

- (\*) “The Production and Handling of Clean Milk, including Practical Milk Inspection.” by Kenelm Winslow; and **Essentials of Milk Bacteriology**, by H. W. Hill, M.D. Cloth, 6½ x 9¾, xiv plus 367 pp, 101 illustrations, including 1 colored and 16 full page plates 3 25

A complete, plain, practical and authoritative guide to the production, inspection, analysis, handling and distribution of milk for veterinary, agricultural and dairy students, farmers, health officers, milk inspectors, practical dairymen, sanitarians, country gentlemen, physicians and others interested in matters pertaining to dairying and hygiene.

**WYMAN.** (\*) “Bovine Obstetrics.” By M. G. De Bruin. Translated by W. E. A. Wyman, M.D.V., V.S.

See also “De Bruin.”

- (\*) “Catechism of the Principles of Veterinary Surgery.” By W. E. A. Wyman, M.D.V., V.S. Cloth, size 6 x 9, 321 pages ..... 3 50

Concerning this new work attention is called to the following points:

- 1.—It discusses the subject upon the basis of veterinary investigations.
- 2.—It does away with works on human pathology, histology, etc.
- 3.—It explains each question thoroughly both from a scientific as well as a practical point of view.
- 4.—It is written by one knowing the needs of the student.
- 5.—It deals exhaustively with a chapter on tumors, heretofore utterly neglected in veterinary pathology.
- 6.—The only work in English specializing the subject.
- 7.—The only work thoroughly taking into consideration American as well as European investigations.
- 8.—Offering practical hints which have not appeared in print, the result of large city and country practice.

WYMAN (continued)

- (†) “**The Clinical Diagnosis of Lameness in the Horse.**”  
By W. E. A. Wyman, D.V.S., formerly Professor of  
Veterinary Science, Clemson A. & M. College, and  
Veterinarian to the South Carolina Experiment  
Station. Cloth, size 6 x 9 1-2, 182 pp., 32 illus.... 2 50
- (†) “**Tibio-peroneal Neurectomy for the Relief of Spavin-  
Lameness.**” By W. E. A. Wyman, M.D.V., V.S.  
Boards, size 6 x 9, 30 pages, illustrated..... 50
- Anyone wanting to perform this operation should procure  
this little treatise; he will find it of considerable help.—*The  
Veterinary Journal.*

**ZUILL.** “**Typhoid Fever; or Contagious Influenza  
in the Horse.**” By Prof. W. L. Zuill, M.D., D.V.S.  
Pamphlet, size 6 x 9 1-4, 29 pages..... 25

**ZUNDEL.** “**The Horse's Foot and Its Diseases.**” By  
A. Zundel, Principal Veterinarian of Alsace Lorraine.  
Translated by Dr. A. Liautard, V.S. Cloth, size  
5 x 7 3-4, 248 pages, illustrated..... 2 00

---

*Any book sent prepaid for the price. Send for  
Complete Descriptive Catalogue*

**WILLIAM R. JENKINS CO.**

851 and 853 Sixth Avenue,

NEW YORK.













