

## Historic, archived document

Do not assume content reflects current scientific knowledge, policies, or practices.



U. S. DEPARTMENT OF AGRICULTURE.

---

Report No. 62.

---

CULTIVATION

OF

CIGAR-LEAF TOBACCO IN FLORIDA.

BY

MARCUS L. FLOYD,

OF THE DIVISION OF SOILS,

IN COOPERATION WITH THE DIVISION OF VEGETABLE PHYSIOLOGY  
AND PATHOLOGY.



WASHINGTON:

GOVERNMENT PRINTING OFFICE.

1899.

## RECENT PUBLICATIONS OF THE DEPARTMENT ON TOBACCO.

---

*Bulletin No. 11, Division of Soils.*—Tobacco Soils of the United States, a Preliminary Report upon the Soils of the Principal Tobacco Districts, by Milton Whitney, Chief of Division of Soils.

*Farmers' Bulletin No. 60.*—Methods of Curing Tobacco (revised edition), by Milton Whitney, Chief of Division of Soils.

*Farmers' Bulletin No. 82.*—The Culture of Tobacco, by Otto Carl Butterweck.

*Farmers' Bulletin No. 83.*—Tobacco Soils, by Milton Whitney, Chief of Division of Soils.

Cultivation of Tobacco in Sumatra, by Emile Mulder.

*Report No. 59.*—Curing and Fermentation of Cigar-leaf Tobacco, by Dr. Oscar Loew, of the Division of Vegetable Physiology and Pathology.

*Report No. 60.*—Temperature Changes in Fermenting Piles of Cigar-leaf Tobacco, by Milton Whitney and Thos. H. Means, of the Division of Soils.

---

<sup>1</sup>Since its establishment in 1862 the Department of Agriculture has issued various publications of a miscellaneous character not properly belonging to any of its established series, which have, up to the present time, remained practically unclassified. These publications, fifty-eight in number, have heretofore been known as "unnumbered reports," and are herewith brought into a series and assigned numbers—1 to 58.

U. S. DEPARTMENT OF AGRICULTURE.

---

Report No. 62.

---

CULTIVATION

OF

CIGAR-LEAF TOBACCO IN FLORIDA.

BY

MARCUS L. FLOYD,

OF THE DIVISION OF SOILS,

IN COOPERATION WITH THE DIVISION OF VEGETABLE PHYSIOLOGY  
AND PATHOLOGY.



WASHINGTON:

GOVERNMENT PRINTING OFFICE.

1899.

## LETTER OF TRANSMITTAL.

U. S. DEPARTMENT OF AGRICULTURE,  
DIVISION OF SOILS,  
*Washington, D. C., July 29, 1899.*

SIR: In pursuance of the work of this Division, and in order to interpret the results obtained in the investigation of the tobacco soils of the United States, particularly to determine whether the crops produced on the types of the tobacco soils are the best obtainable with our present knowledge and skill in manipulation, it seemed advisable to add to the staff of this Division a person trained by experience in the tobacco business.

In reviewing the situation carefully it seemed evident that the most striking advances in recent years have been made in the development of the cigar-tobacco industry of Florida. A request was therefore made on the Civil Service Commission to establish an eligible register of those who had thorough knowledge of the Florida methods and who had had experience in the development of the industry there. Mr. M. L. Floyd, of Quincy, Fla., was appointed tobacco expert in this Division as a result of this examination.

The present development of the tobacco industry in Florida was started about twelve years ago by several prominent New York firms. In 1888 Mr. Floyd assumed general charge of the operations in Florida of one of these firms, producing the first year 25,000 pounds of tobacco and purchasing from the farmers 200,000 pounds for fermentation and packing. In 1894 he took a similar position with another firm in Quincy, at that time planting from 800 to 1,000 acres in tobacco and buying extensively from the farmers. Thus for many years he was connected with two of the largest firms operating tobacco plantations in Florida. He had general oversight of the plantations and of the manipulation of the tobacco in the barns and curing sheds, and has also assisted in selling the tobacco after it had been fermented and packed. In 1897 he secured a packing house of his own and was in business for himself up to the time of his connection with this Department.

The work of the Florida growers, while essentially practical, has really been developed along scientific lines.

The accompanying manuscript embodies the results of Mr. Floyd's knowledge and experience, and its publication is recommended as Report No. 62 of this Department.

Respectfully,

MILTON WHITNEY,  
*Chief of Division, in Charge of Tobacco Investigations.*

Hon. JAMES WILSON,  
*Secretary of Agriculture.*

## CONTENTS.

---

	Page
Requirements of the cigar-leaf trade .....	5
Cultivation of Cuban tobacco in Florida .....	8
Field culture .....	9
Harvesting .....	11
Curing .....	12
Cultivation of Sumatra tobacco in Florida .....	13
Selection and preparation of seed bed .....	13
Field work .....	13
New v. old land .....	14
Fermenting, grading, sorting, and baling Florida-grown Cuban tobacco.....	15
The manipulation and packing of Sumatra tobacco.....	19
Development of the tobacco industry in Florida .....	20
"Old Florida" tobacco .....	21
Experiments in improving tobacco .....	21
Changes in methods and improvement in style and quality .....	22
Cost of growing tobacco in Florida .....	23
Kind of barn desired and its cost .....	25
Estimates and cost of construction of barn.....	26
Tobacco grown by the farmer compared with that grown by the tobacco planter .....	27

# ILLUSTRATIONS.

## PLATES.

	Page.
PLATE I. Fig. 1.—Seed bed, with part of the canvas cover removed, as the plants are ready to be reset. Fig. 2.—Part of a 10-acre tobacco field with plants just set. The whole is covered with cheese cloth fastened to wires running across a wooden frame, the frame being 9 feet high.....	8
II. Fig. 1.—Part of a 10-acre tobacco field covered with cheese cloth, showing the details of the outside structure of the frame. Fig. 2.—The outside of a 10-acre tobacco field covered with cheese cloth. (From an elevation some distance away.).....	10
III. Fig. 1.—Sumatra tobacco under cheese cloth on June 25, just after the plants had been topped. Fig. 2.—Sumatra tobacco under cheese cloth, with plants maturing and laborer priming off the ripe leaves. The leaves average from 16 to 18 inches in length.....	12
IV. Fig. 1.—Sumatra tobacco left to mature for seed. This also illustrates the development in the modern method of securing fine wrappers when not grown under canvas and where a fine, thin Sumatra wrapper is desired. Fig. 2.—The method of stringing the leaves and hanging in the shed.....	14
V. Fig. 1.—Exterior view of a curing and packing house. The fermentation is done in the basement and the sorting and packing on the first floor. Fig. 2.—Assorting and classifying tobacco on the first floor of the packing house.....	18
VI. Fig. 1.—Putting up the Cuban tobacco into carrots. Fig. 2.—Samples of 12, 14, and 16 inch carrots ready to be baled.....	20
VII. Fig. 1.—Making up a bale of Cuban tobacco. Fig. 2.—The Cuban bale with and without the canvas cover.....	22
VIII. Fig. 1.—The Sampson jack-press, used for making the Sumatra bale. Fig. 2.—A finished Sumatra bale of Florida-grown tobacco.....	24

## TEXT FIGURES.

FIG. 1. The Cuban press or baling frame, with the sticks and mallet used in the process.....	17
2. Shed filled with primed leaves, with the ventilators open.....	25
3. Ground plan of tobacco barn.....	27
4. Side elevation of tobacco barn.....	27
5. End elevation of tobacco barn.....	28
6. Middle section of tobacco barn.....	29



# CULTIVATION OF CIGAR-LEAF TOBACCO IN FLORIDA.

## REQUIREMENTS OF THE CIGAR-LEAF TRADE.

The demand of the trade for cigar-leaf tobacco is exceedingly vacillating. This is very apparent to the man who goes out on the road to sell tobacco. There is hardly a class of men in any one line of business so much at variance in their opinions and wants as the dealers in and the manufacturers of cigar-leaf tobacco. In view of the fact that we have not yet arrived at the point in cultivation where any section produces a uniform lot of tobacco, perhaps this difference of opinion and variety of qualities desired on the part of the dealer and manufacturer is a good thing, as we can be sure that, no matter what we have so long as it is really tobacco, we can find a manufacturer who can and will use it, provided the price is low enough. There are stogies, cheroots, and a world of low-grade cigars consumed each year, and to produce tobacco suitable for these goods we need make no special effort. What we want is to produce a tobacco for a cigar of better grade and higher price.

All are fairly well agreed that for wrapper purposes the Sumatra furnishes the ideal leaf, while for fillers, where quality is needed, the island of Cuba produces the best leaf. As these tobaccos are the standard of quality and style sought after, it should be the aim of each tobacco-growing section to produce as nearly as possible a tobacco that will take the place of these imported goods, both in appearance and quality. The first essential in all cases is that the tobacco, whether wrapper or filler, burn smoothly and freely. Next there must be quality; the taste must be pleasant, not rank and strong, nor too mild. When the taste is pleasant, not sharp, the aroma will invariably be good. The cigar that possesses the above qualities will please the smoker and leave him wanting another, and thus the manufacturer will also be pleased. The wrapper must have style. At present the Sumatra is the standard by which all other wrapper leaf is compared, both as to quality and appearance. That means that a wrapper, to be acceptable to the manufacturer of the high-grade cigars, must be light in color, rich in grain, thin in texture, small in vein and stem, very elastic, and of good burning quality. The most desirable

sizes are 16 and 18 inch leaves, as from leaves of these sizes the manufacturer will get four wrappers from each leaf and have very little waste, which is always quite an important item to consider. We will assume, for illustration, that a manufacturer buys 2 pounds of Sumatra wrappers for which he pays \$4 per pound. These 2 pounds will wrap 1,000 cigars, all "first," at a total cost of \$8. There is no loss, the entire leaf being used as a wrapper, and the manufacturer has the satisfaction of knowing that for each 2 pounds of Sumatra wrapper bought 1,000 cigars will be wrapped and will be uniform in color.

Whenever we can produce in this country a wrapper that will come up to the above requirements, we shall find that the trade will take it and pay liberally for it, but as long as we offer to the trade inferior goods the prices will be low. Of course the first essential is that the wrapper leaf be grown; the next is that it be properly cured, assorted, and classified. A manufacturer will never pay a high price for a bale of tobacco unless he can calculate just what it will yield him, and this he can only do when it is well and carefully selected. The tobacco should be uniform in size, color, and texture, as when a bale of tobacco contains a variety of colors, sizes, and textures, the buyer is left to guess its value, and the price will necessarily be low.

For filler purposes, Cuban tobacco makes the standard. The size of the leaf should be from 12 to 14 inches, not longer, and it should not be very dark and heavy, as many seem to think, but of medium body and of a rich brown color, burning smoothly and freely. All manufacturers agree that it is never well to make a cigar from only one kind of tobacco; that is, a cigar should not be made in which the entire filler is Ohio, Pennsylvania, or Florida tobacco, but tobacco should be taken from these various sections and a combination tried until tobaccos are found that blend well. When this result is secured the combination is adopted and a new brand of cigar is put on the market. This is especially true of the Cuban tobacco. Many of the manufacturers would gladly reduce the amount of imported Cuban tobacco if they could be supplied with a domestic tobacco that would blend well with it.

We have no choice in the matter. The trade demands the quality contained in the Cuban tobacco and the style of the Sumatra leaf, therefore we must try to produce what they want. The tobaccos produced in the States of Pennsylvania, Ohio, and Wisconsin, and in the Connecticut Valley, go far toward supplying the manufacturers of our country; but unfortunately these goods find their way into medium and low-priced cigars, and our higher-priced and best cigars are made from imported goods. Just where the fault lies and what is the remedy is hard to say.

This much, however, can be said of some of the States, especially of Massachusetts and Connecticut—that a very pretty leaf is produced which one would think would be acceptable to the trade and find a place in the higher-priced cigars, but such is not the case except to a limited degree. Some manufacturers do use the Connecticut wrapper

on fine cigars, getting about two wrappers from or near the point of the leaf, where it has a rich grain. The remainder of the leaf being sleek and glossy—looking “seedy,” as the manufacturer would say—can only be used on medium and low-priced cigars. The Zimmer Spanish and Little Dutch produced in Ohio make a good fight for a place in the medium-priced stock and are very acceptable to the smoker on 5-cent cigars.

For the past ten years Florida has done much to show what could and should be done. Finding that the trade could not be forced into taking whatever might be produced, it was determined to grow as nearly as possible a tobacco similar both in appearance and quality to that grown on the islands of Sumatra and Cuba. To do this the best seed obtainable was secured from these islands, and, as far as practicable, their methods of cultivation, harvesting, fermenting, and manipulation were employed. How well these efforts have succeeded may be judged from the fact that Florida fillers, when well cured and baled, bring to-day as high as 45 cents per pound, while wrappers bring from 50 cents to \$2 per pound, according to style and quality.

This applies to the Cuban variety. So far as the production of the Sumatra type of tobacco in Florida is concerned, there is equal assurance of success. Unquestionably bales of that type of tobacco have been grown and packed that the best experts could not distinguish from the imported goods, and some of this, grown under shade, has been sold for \$4 per pound. Of course these bales contain tobacco that has been selected with great care, each leaf being perfect. Two pounds of such tobacco would wrap 1,000 cigars, all “first,” and equal to those wrapped with imported goods. This shows that when we offer to the trade the proper goods it is willing to pay for them. We have much yet to learn, as the per cent of this finer grade of wrapper has been very small compared with the quantity grown, thus causing the selection and classification of tobacco to be very expensive, as it requires the assorting of a large quantity in order to obtain a very small percentage of desirable wrapper leaf. However, as before stated, we have met with sufficient success to warrant the belief that in the near future we will produce a leaf that will take the place of the imported Sumatra. What may seem strange regarding the Florida-grown Sumatra is that from the same crop we are able to obtain light spotted leaves that are identical with the imported Sumatra, also light unspotted leaves that closely resemble the finest type of wrapper grown on the island of Cuba, each possessing the rich grain and general appearance of the imported goods.

All this is written relative to Florida in order to show that a high price can only be obtained when we offer to the trade a tobacco which resembles and will, in a great measure, take the place of the goods imported from Cuba and Sumatra. Undoubtedly Florida is gradually approaching this condition. It is a fact that during the past two years

much of the tobacco grown in all parts of the State has had no ready sale, and many of the growers have become discouraged. This, however, is due to the fact that the growers are inexperienced as to the culture, harvesting, and general care necessary for the production of fine tobacco.

From the foregoing statements it can be seen that the cigar trade, as applied to the higher-grade goods, demands the quality of the Cuban tobacco and the style of the Sumatra leaf. With these facts before us, it is unquestionably the duty of each tobacco-growing section to try to produce a tobacco that will meet these requirements. While we may not hope to entirely displace the Cuban fillers, we certainly can hope to produce a filler that will blend well with these goods, and thus greatly reduce the quantity of Cuban tobacco imported into this country.

#### CULTIVATION OF CUBAN TOBACCO IN FLORIDA.

The land for the seed bed should preferably be fresh, rich hammock, having a light gray soil, moist but not wet. Dry, thirsty land should be avoided. One hundred square yards of seed bed are necessary for each acre to be grown, and two tablespoonfuls of seed are needed to sow this area. If fresh hammock is available, the timber should be cut in November or December and the wood stacked, so that it will dry and be ready for burning when the seed bed is made. The time for sowing the seed is from January 15 to March 1. About one week before sowing the seed the bed should be thoroughly cleaned, and all straw and leaves carefully raked off, after which the ground should be "burned." This burning is done for two reasons; first, to destroy all grass or weed seeds or roots that might otherwise come up and choke the tobacco plants; second, to obtain the fertilizing properties of the hard wood. It is done in the following manner:

After raking the surface of the land well, skids are laid 4 feet apart, running the full length of the plot to be sown. A pile of wood is then laid across the skids, running the full width of the bed. The fire is started, and as fast as the ground is thoroughly burned and covered with ashes the fire and wood are drawn along the skids, wood being continuously added. The fire is moved along the skids until the entire bed has been burned, after which the ground is again raked to remove the coals, letting the ashes remain. The soil is then spaded to a depth of about 4 inches, carefully taking out all roots and tufts. If the soil needs fertilizing after the spading is completed (the seed bed should be very rich in order to give thrifty, healthy plants), such quantity of fertilizer as may seem necessary is sown broadcast over the surface. Any complete guano may be used. The bed is again raked with an iron-toothed rake to mix the fertilizer well with the soil and to have the surface smooth and loose.

The bed is divided into "lands" about 4 feet wide, leaving narrow walks between. Each land is measured, to see how many square



FIG. 1.—SEED BED WITH PART OF THE CANVAS COVER REMOVED AS THE PLANTS ARE READY TO BE RESET.



FIG. 2.—PART OF A 10-ACRE TOBACCO FIELD WITH PLANTS JUST SET.

The whole is covered with cheese cloth fastened to wires running across the wooden frame, the frame being 2 feet apart.



feet it contains, and enough seed is mixed with ashes to sow one land at a time at the rate of 2 tablespoonfuls to each 100 square yards. After the sowing is completed a heavy roller is drawn over the bed, thus packing the seed well into the soil, making the surface smooth, and preventing the rapid drying out of the surface, that would otherwise take place. If the ground is dry, it should be watered immediately after sowing the seed, and this should be continued from time to time as the soil may require. In the absence of rain after the plants are up the watering should be continued. An illustration of one of the seed beds is given in Plate I, fig. 1.

There are many enemies to the seed bed in the way of insects, so a careful watch is necessary. As soon as there is any appearance of flea-beetles or horn worms it is the practice to spray the bed with Paris green mixed with water, at the rate of one teaspoonful to two gallons of water. In order to keep down all insects the bed is sprayed at least three times a week. It is usual to have plants large enough to transplant within sixty or seventy days from the time of sowing the bed. This applies to the January and February sowings; March and April sowings will give plants from forty to sixty days after being sown. The sowings are arranged according to what the requirements are likely to be in the planting season. In selecting early seed beds, it is best to get lands sloping from north to south, protected on the north by forests and open on the south to let in the midday sun. It is safer to protect these early beds by covering them with cheese cloth stretched on frames made around and over the beds. (Pl. I.)

When the plants are drawn for transplanting, great care should be taken to get as much root as possible. Each person drawing plants should be provided with a bucket of water, and as soon as the plants are drawn the roots should be washed to remove all dirt that may have stuck to them. The plants are then placed in a basket, roots down, and immediately set out. This washing of the roots is not generally practiced, but it has been found that the plants live and grow better when the roots are clean. After each drawing of the plants from a bed the soil should be immediately watered, in order to close up the places from which the plants were drawn. After all the plants have been drawn from the beds, all vegetation should at once be cut down and the bed covered with straw and leaves to a depth of about 6 inches. This covering prevents the grass, weeds, etc., from growing and also serves as a mulch. With this care a plot of land may be used for several years for the growing of plants.

#### FIELD CULTURE.

The soil selected should be light, gray, sandy loam with clay subsoil. The land should be broken up in November or December, allowing the plow to cut from 4 to 6 inches deep, according to the nature of the soil and the quantity of fertilizer used. If a large quantity of fertilizer is

used, such as cotton seed and stable or barn manure, it should be thrown broadcast over the surface and plowed in. This should be done about six weeks before the time of setting out the plants. About one week before setting the plants the land is laid off in rows 4 feet apart, listed with 2 furrows, thus making a ridge on which to set the plants. On the morning before setting out the plants the top of this ridge is made flat and smooth by means of a hoe or by a board attached to a plow drawn over the ridge. This leaves the top of the ridge flat and smooth and ready to receive the plants, which should immediately be set about 14 inches apart in the drill. As it is always desirable to get a uniform growth, great care should be exercised to have each plant live. Replanting should be done as quickly as it is possible to determine where fresh plants are needed. If the ground is moist and showers frequent, watering the plants is unnecessary, but if the ground is dry they should be watered immediately after setting and each day thereafter as long as the plants require it. The quantity of water used is in all cases governed by the condition and nature of the soil. After setting, the plants should not be disturbed for at least six days. If the soil becomes packed and hard, a furrow should be run on each side of the row, using a small straight plow and letting it run well down. This should be followed immediately by two sweep furrows, which will put the plants on a smooth ridge. The hoe is then used, carefully stirring the soil about the plants. From this point on the cultivation should be rapid and shallow. When the plants begin to "button" cultivation should stop. Early or low topping is not desirable, as it throws too much growth in the leaves, making them large and coarse. There should be 14 to 16 leaves to the stalk after a plant is topped. After the plants are topped, suckers will start at each leaf. These must be broken off at least twice each week. Of course in plowing and hoeing great care is exercised to preserve the soundness of the leaves.

The battle with the worm begins in the seed bed and does not end until the tobacco is harvested. As soon as the plant begins to grow after being transplanted, a preparation is made of Paris green and meal, mixed well together, at the rate of one tablespoonful of Paris green to one gallon of meal. This is sprinkled directly in the bud of the plant, and its use is continued until the plant is topped. By applying this with great care twice a week the bud worm, which is the greatest enemy of the crop, is kept off. The horn worm is also a great pest. Poisoning is resorted to in order to get rid of it, using cobalt and strychnine mixed with honey. One drop of this mixture is put in each blossom of the Jamestown weed. The blossoms are distributed over the fields in little stands prepared for this purpose, the stands being about 6 feet high, so as to enable the blossoms to be seen above the tobacco plants. The horn-fly is attracted to the blossom, and one sip of its poisoned contents proves deadly. In this way many of the horn





FIG. 1.—PART OF A 10-ACRE TOBACCO FIELD COVERED WITH CHEESE CLOTH, SHOWING THE DETAILS OF THE OUTSIDE STRUCTURE OF THE FRAME.



FIG. 2.—THE OUTSIDE OF A 10-ACRE TOBACCO FIELD COVERED WITH CHEESE CLOTH. From an elevation some distance away.



flies are destroyed. However, as this means of extermination can not be depended upon entirely, a force of help is kept continually going over the field picking off the worms.

#### HARVESTING.

As soon as the first leaves at the bottom of the stalk begin to ripen harvesting is begun by plucking off the first four leaves from the bottom and transporting them to the curing sheds in baskets. These baskets are 36 inches long, 18 inches wide, and 12 inches deep, holding about 600 leaves, or enough to fill 20 laths. These baskets are carried from the field to the curing shed by men, if the curing shed is near; if not, they are carried in wagons. Each wagon has a frame that will carry 16 of these baskets, thus in one load transporting 9,600 leaves, enough to fill 220 laths. On reaching the curing sheds these baskets are received by the foreman of the barn work, who places them on tables, around which he has a number of women engaged in "stringing." They take the tobacco from the baskets and put it on strings by means of large needles. The leaves are placed back to back and face to face. This is done to prevent the leaves from cupping or folding over each other. Thirty-five or 40 leaves are put on one string, according to the size of the leaf. Each end of the string, as soon as filled, is attached to a lath 4 feet 4 inches long, and the leaves are evenly distributed along the string. The lath is then hung in the barn, where it remains until the leaves are cured. The method of stringing the leaves is shown in Plate IV, fig. 2.

If the tobacco gives promise of being "wrapper," that is, if it is light green, very sound in leaf, and of desirable size, it should be "primed" at an early stage of ripening. If, however, appearances indicate that it will prove "filler" tobacco, it should be allowed to thoroughly ripen. After priming six or eight leaves the remainder will ripen sufficiently near the same time to permit the cutting of the stalks. When the stalk is cut it is placed on what is called a hand barrow, carried by two men. These barrows will hold about eighty stalks, or enough to fill ten laths. On reaching the barn these barrows are placed on a table and the stalks are immediately put on laths by means of a spear fitted on the end of the lath, eight or ten stalks being put on each lath. These laths are then put in the barn just where they will remain until the tobacco is cured.

If the soil is rich and the season propitious a second profitable crop can be produced from the suckers. As soon as the original crop is topped suckers will sprout from each leaf. These, of course, should be broken off as soon as they appear, otherwise they will sap, hinder, and check the growth of the leaves. When all of the leaves have been primed from the original stalk, except the four or six leaves at the top, two suckers should be allowed to grow from the bottom of the stalk. These two will be well started by the time the top leaves of the original

stalk are ripe. The stalk should then be cut just above where the suckers sprout and cultivation should begin at once, the soil being brought up around the old stubble. The suckers should not be allowed to have more than six leaves each. The growth of these will be rapid and they will mature quickly. When ripe the leaves should not be primed, but the stalks should be cut. It is often the case, where the seasons are favorable, that the suckers will be very fine in quality for filler purposes. Where the original crop yields 600 pounds per acre it is often the case that 400 pounds can be produced from the second growth or sucker crop. As soon as all of the tobacco is harvested, the stubble is dug or pulled up and the field sown in cowpeas. In about three weeks the pea vines will cover the ground, thus protecting it from the midsummer sun. In the fall the vines are plowed under and prove of great benefit to the soil.

#### CURING.

When the tobacco is primed from the stalk it should not take longer than two weeks to cure; when hung on the stalks three or four weeks are necessary. The manipulation of the barn or curing shed is entirely governed by the condition of the weather and the nature of the tobacco, and no fixed rule or rules can be given. However, in a general way it may be said that if a barn is filled with green tobacco, and the weather is hot and dry, the ventilators should be tightly closed for about three days, by which time the tobacco will be quite yellow. The barn should then be opened at night and kept closed during the day. This is done to prevent rapid curing, as rapid curing destroys the life of the leaf and gives uneven colors. If there are frequent showers and but little sunshine, the barn should be closed and fires started in small charcoal heaters distributed throughout the barn. These fires should be continued as long as is necessary to keep the barn in proper condition. Where the charcoal heaters are not available, wood, which has little odor and as little smoke as possible should be used as the smoke is taken up by the tobacco and the odor of it is noticeable long after the tobacco is cured. It is very important to dry out the barn without giving the tobacco any foreign odors. To obtain the best results the tobacco should become fairly moist and be fairly dried out once in every twenty-four hours.

When the stems of the leaves are thoroughly cured they are ready to be taken to the packing house. To get the tobacco in a condition to be handled all of the places for ventilation are left open for one night, opening them about 6 o'clock in the evening. The next morning the tobacco will be in what is called "good case;" that is, it will have taken up moisture and become soft and pliable. The barn is then tightly closed in order to retain the moisture. The tobacco is taken from the poles and stripped from the stalk or taken from the string, as the case may be, and is packed in bundles that weigh from 35 to 40

FIG. 1. SUMATRA TOBACCO UNDER CHEESE CLOTH ON JUNE 29, JUST AFTER THE PLANTS HAD BEEN TOPPED.



FIG. 2. SUMATRA TOBACCO UNDER CHEESE CLOTH, WITH PLANTS MATURING, AND LABORER PIMING OFF THE RIPE LEAVES.





pounds. These bundles are made by means of a box 30 inches long, 12 inches wide, and 12 inches deep. Strings are placed at even distances across the box and pressed down well into little notches cut in the edge of the side. A sheet of paper, 28 inches by 50 inches, is then laid inside the box, on which the tobacco is put, placing the heads of the leaves to each end of the box and allowing the tips to lap in the center. When the box is well filled the paper is folded over the top and the strings securely tied. This gives a neat and easily handled package. In this condition it is delivered to the packing house as quickly as possible. In the barn the following grades are kept separate—bottom leaves, middle leaves, and top leaves—each package being marked to show its contents. This ends the work of the farmer.

### CULTIVATION OF SUMATRA TOBACCO IN FLORIDA.

#### SELECTION AND PREPARATION OF SEED BED.

All that has been written relative to the selection of the land and the preparation of seed beds for the Cuban tobacco applies to the Sumatra as well, except that the Sumatra beds are sown later. It is the aim of the farmer to get all of the Cuban crop set out by May 15, about which time the setting of the Sumatra crop begins. The setting of the Sumatra crop is finished about the 15th or 20th of June. All the seed beds must be sown with the view of having the plants when needed.

#### FIELD WORK.

New, low hammock is decidedly the best land on which to grow Sumatra tobacco. The soil should be light gray with a clay subsoil. Sumatra tobacco must have a rapid growth in order to produce light, thin wrappers, and if the land is not rich it must be made so by fertilizers. A little complete guano, not exceeding 200 pounds per acre, may be used to stimulate the plants at the early stage of growth. Cotton seed, cotton-seed meal, and cotton-seed hull ashes are generally considered the best fertilizers for tobacco. If a great quantity of cotton seed is used it should be crushed and scattered broadcast over the land and plowed in. This is done about six weeks before the time for setting the plants. The quantity of fertilizer is governed in all cases by the original strength of the land. When not more than 75 or 100 bushels of cotton-seed per acre are used they are put in the drill. This is done by bedding out the land about four weeks before the time of setting the plants, immediately after which the fertilizer is evenly distributed along the water furrow and covered with two furrows. This is allowed to remain about three weeks, when a 10-inch solid sweep is used to break out the list in which the fertilizer has been put, letting the plow run well down, thus mixing the fertilizer with the soil. This furrow is followed immediately by two other furrows, throwing the soil back and making a ridge on which to set the plants. Before setting out the plants the

tops of these ridges are knocked off with a hoe or board, leaving them smooth and flat. The plants are given a distance of 12 inches in the drill. Of course great care is used to make every plant live, as a uniform growth is essential if a uniform crop is to be harvested. Two or three days after the first setting the field is gone over, putting fresh plants wherever one of the original setting seems to be drooping or dying.

The cultivation is the same as that given the Cuban variety, and it must be rapid and shallow. The ground should be stirred at least once each week until the plants begin to bud, at which time cultivation should stop. It is very essential that the plants should have a continuous, rapid growth from beginning to maturity; they are often given a second application of fertilizer. For this cotton-seed meal or cotton-seed-hull ashes are usually applied when the plants are 12 or 14 inches high. This fertilizer will be available when most needed by the plants, furnishing as it does food for the many feeders or surface roots.

The same means used for keeping the worms off the Cuban crop are also used in the case of the Sumatra; and as the principal value of the Sumatra plant is its wrapper leaves, great care is exercised to preserve the soundness of the leaf. The Sumatra tobacco is topped higher than the Cuban; that is, only the seed bud is taken out, and all of the leaves are allowed to grow. If the land is exceedingly rich it is found best not to top at all, but to allow the plants to go to bloom. To top in that case causes the leaves to thicken and curl. It has been found by experience that Sumatra tobacco should be harvested at an early stage of ripeness, as the leaves will cure lighter and be more elastic; that is, it will have more life. It is usual to take four to six leaves at each priming, thus going over the field four or five times before the whole crop is harvested. The methods and means of transporting this tobacco to the curing shed are the same as employed in transporting the Cuban variety, and the work in the barn or curing shed is also the same. The first priming, which means the first four leaves taken from the stalk, also the last priming, which means the last four or six leaves taken from the top of the stalk, are kept separate. Thus there are three grades, as follows: Bottom leaves, middle leaves, and top leaves.

When the tobacco is sufficiently cured it is packed in paper bundles, the same as described under Cuban tobacco, and delivered to the packing houses, each bundle being marked so that its contents can be known.

#### NEW *v.* OLD LAND.

As stated in the beginning of this article, new, low hammock land is necessary, or has been so considered. Some excellent Sumatra has been grown on old land, but this is decidedly the exception and not the rule. However, in 1896, as an experiment, a New York company operating in Gadsden County, Fla., built a shed over 1 acre of old land.





FIG. 1.—SUMATRA TOBACCO LEFT TO MATURE FOR SEED.

This also illustrated the heavy loss in the market, many of the young plants withered when not drawn, and the survivors were a fine strain Sumatra wrapper tobacco.



FIG. 2.—THE METHOD OF STRIPPING THE LEAVES AND HANGING IN THE SHED.



The shed or arbor was 9 feet high and covered with laths, giving only half cover; that is, the laths were 2 inches wide and were placed 2 inches apart, so that there was half sunshine and half shade. This acre was made very rich and Sumatra tobacco was planted. The result was all that could have been hoped for, as they harvested a finer crop than had ever before been raised on the finest hammock land. In 1897 they increased their experiment to 5 acres, the result being as good as in 1896. In the following year, 1898, this concern planted more than 200 acres on old land, under shade, harvesting about 800 pounds per acre; and they claim that at least 50 per cent was wrapper. I have examined these tobaccos and I am sure that the island of Sumatra has never produced a finer type of wrapper leaf; and, what is more, this tobacco is just as acceptable to the trade as the finest imported Sumatra. All the farmers who are able to do so are building shades, and I think there will be at least 600 acres planted under shade in Gadsden County this year.

#### FERMENTING, GRADING, SORTING, AND BALING FLORIDA-GROWN CUBAN TOBACCO.

When the tobacco is first received from the curing shed it should be divided into the following grades: Medium to light leaves, medium to dark leaves, and fillers, making three sizes to each grade. It should then be tied in hands, about fifty leaves to the hand. This assortment is made to give each grade of tobacco such curing in bulk as it may need. As soon as the tobacco is tied in hands, proceed to bulk it. The light, thin tobacco, which needs but little curing, is put in small bulks of from 3,000 to 5,000 pounds; the medium to dark tobacco is put in bulks of from 8,000 to 10,000 pounds, as more curing is required for the dark tobacco. The fillers should be put in bulks of from 10,000 to 15,000 pounds, as they need thorough curing, and the larger the bulk the more intense is the heat. Allow these bulks to remain from six to eight days, according to the condition of the tobacco when bulked, then proceed to rebulk in the following manner: Six or eight cases should be filled with tobacco taken from the top of the bulk and then set to one side. Then take tobacco from the old bulk and lay the foundation of the new, continuing until the bulk is about half removed. Take the tobacco from the six cases first removed from the top of the bulk and put on the new; refill these six cases with the tobacco from the center of the old bulk, again setting these to one side; proceed to take the remainder of the old bulk and put on the new until the old bulk is entirely removed; then take the six cases that were taken from the center of the old bulk and put this tobacco on top of the new. Thus the top and bottom of the old bulk have become the center of the new one. The outside layers are also put in the center of the new bulk, and the center layers of the old bulk become the outer layers of the

new. These bulks are made about 6 feet wide and 12 feet long, the length and width being governed by the quantity to be bulked. In all cases the length and width of the bulk should be so arranged that when finished it will be at least 6 feet high.

After the bulk has been once repled allow it to remain about ten days, when the same process of rebulking should be repeated. The second time the tobacco is rebulked it should be allowed to remain about fifteen days, and if the tobacco had sufficient moisture in the beginning the wrappers at the end of that time should be sufficiently cured to assort and bale. The fillers and low grades of wrapper can not be entirely cured with the moisture the tobacco had when received from the curing shed. These grades are allowed to remain in bulk until they are thoroughly dried out, and they are then given moisture by dipping them into water. If the tobacco is flimsy and has but little gum, a preparation should be made of stem juice. This is done by boiling Havana stems and pressing them well, making the juice quite thick, then adding 1 bucket of juice and about 1 gallon of sour wine to a tub of water. Dip the heads of the tobacco about 4 inches into the water and shake well, thus distributing the water through the leaves. The tobacco should then be lightly laid into cases and allowed to remain for about twenty-four hours, by which time the moisture will have been taken up and the tobacco become uniformly soft. Then proceed to bulk as before, keeping a close watch and rebulking from time to time as the tobacco may need, until it is thoroughly cured.

The above-described work should be done in a room prepared for this purpose called the sweat room. Steam pipes should run through this room, the pipes being so arranged that the room can be filled with steam whenever desired. The mean temperature of the room should be about 75°. When filling the room with steam all tobacco should be covered with blankets. The steam is not used to soften the tobacco, but to prevent it from drying out, which it will do if the air is allowed to get warm and dry. The temperature given above should be kept throughout the entire building, as it is desirable to keep the tobacco in about the same atmosphere; that is, the tobacco should never be taken from a warm room to a cold one while in the process of manipulation.

The best grades, of course, should always receive attention first. As soon as sufficiently cured, proceed to assort and classify, making the following grades: Light, medium colored, and dark wrappers; light, medium-colored, and dark seconds. Make four lengths of each grade as follows: 12, 14, 16, and 18 inches. The first three grades represent the perfect leaves, the next three grades the imperfect, uneven-colored leaves. In making these assortments measured tills should be provided to receive each grade; each till being marked to show just what grade it contains, thus avoiding the possibility of mixing the various grades. With a force of about fifty women assorting, one inspector for each grade is necessary; that is, there should be one man who thoroughly

understands the classifying of tobacco to receive the light wrappers and to go through them carefully and see that no leaves are put in that do not rightly belong there. Each grade should be inspected in like manner, after which it is handed over to the foreman of the tiers. It is then tied into hands, thirty-five to forty leaves constituting a hand, and packed carefully into cases, great care being taken to keep the leaves even and smooth. The foreman should put a ticket on each case to show its contents. The tobacco remains in these cases for three or four days, by which time the moisture in the leaf becomes uniform. Then give the tobacco to the "carrot" makers, who will make it into what is called Cuban carrots; that is, four hands are tied together, the heads being evened and the tobacco wrapped from head to tip with Cuban bast. Care should be taken to have the outside leaves very smooth, thus making a neat bundle of tobacco which weighs from 1 to  $1\frac{1}{2}$  pounds, according to the size of the leaf, thickness, etc. As soon as the carrots are made proceed to put them in bales, eighty carrots constituting a bale, the material used being the same as is used in Cuba (fig. 1). When the package or bale is complete, it is identical in appearance with those put up in Havana. (See Pls. V, VI, VII.)

As stated in the beginning of this article, the tobacco is divided into three grades when it is first received into the packing house. The first handled is, of course, the grade from which the light wrappers are to be made. In this final selection there will be a lot of low-grade goods which must be used for fillers, and of course these will not be sufficiently cured for baling. So the low grade, or filler goods, are tied in hands and bulked down for further curing. In making this bulk the tobacco should be "petuned," if necessary.

The following preparation is used as a petuning solution by the best packers: To make a mixture of 5 gallons, use 2 gallons of New England rum, 1 gallon of sour wine, one-half pint tincture valerian, 1 ounce of oil of anise seed, one-half gallon black coffee, 1 ounce pulverized cloves, 1 ounce pulverized cinnamon, 2 pounds licorice paste dissolved in water, and sufficient water to make up 5 gallons. Mix this well and allow it

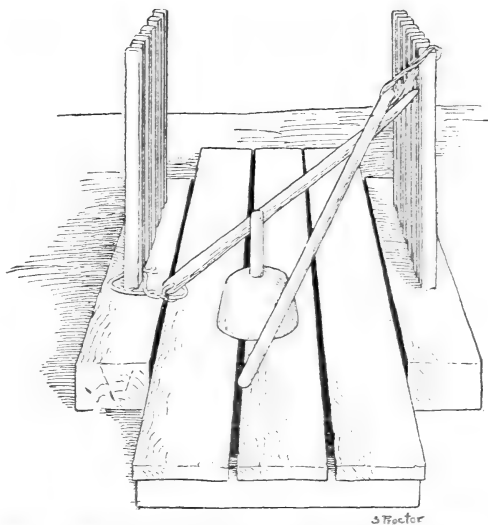

FIG. 1.—The Cuban press or baling frame with the sticks and mallet used in the process

to remain for 24 hours. As the filler tobacco is bulked each layer should be sprayed with this preparation, using a fine atomizer for the purpose. This should be done with great care, as the idea is simply to give the tobacco a rich aroma, such as is found in the best Cuban goods.

These bulks are turned or rebulked from time to time as may be required. When the tobacco is sufficiently cured and aged it is made up into Cuban carrots and baled. At this stage the odor of the petune used may be noticeable, but after the tobacco has remained in the bale for two or three months it can not be detected. The tobacco will have a rich aroma similar to the imported Cuban tobacco. The upper grades, that is the wrappers, should in no case be petuned, only the fillers or low grades being so treated.

All trashy, flimsy tobacco should be thrown out, and only the good, clean leaves put in carrots. The badly torn and trashy tobacco should be put through a hard sweat. These goods should be petuned liberally, thoroughly cured, and stemmed; that is, the stem should be taken out, leaving about 2 inches of stem at the tip of the leaf. The leaves should then be carefully smoothed out and put into pads, called by the trade "book *d* fillers." These are placed on screens and allowed to become quite dry. They are then taken up and put in cases, care being taken to keep the pads straight and all the tips of the leaves pointing in the same direction. As this tobacco is placed in the case it should again be petuned, using a fine atomizer and lightly blowing each layer. The tobacco remains in these cases three or four days, by which time the petune will be thoroughly taken up by the tobacco. Then the tobacco should be baled. In baling great care should be used to keep the pads straight, and the tips of the leaves should point to the center of the bale. In making "book *d* fillers" many scraps or small pieces of leaves—too small to put in the "book *d*" goods—will accumulate. These scraps, or picadura, as they are called by the trade, should be thoroughly cleaned, picking out all stems and shaking the scraps in a coarse sieve, thus getting out all sand, etc. Spread out and allow the scraps to become dry, after which pack them up in cases, petuning with the same care as with the "book *d* fillers." Allow them to remain in the cases two or three days and then bale.

As to the care of the tobacco after it is baled, that depends on the condition of the weather and the nature of the tobacco. The bales containing wrappers should be stored in a cool place, so that fermentation will cease. The bale should be stood on one end for the first two or three weeks after baling, reversing it about three times each week. After that time the bales may be laid flat and stacked three or four deep, reversing this position at least once each week until the tobacco has become well aged and dried out. After this, only a general care is necessary. The low grades, when it is desired that some fermentation should go on even after the tobacco is baled, should be stored in a close warm room and stacked about four bales deep. The position of these



FIG. 1.—EXTERIOR VIEW OF A CURING AND PACKING HOUSE.

The fermentation is done in the basement, and the sorting and packing on the first floor.



FIG. 2.—ASSORTING AND CLASSIFYING TOBACCO ON THE FIRST FLOOR OF THE PACKING HOUSE.





bales should also be reversed at least once a week until fermentation stops. The wrapper grade should be ready for use after being in the bale three months, while the fillers should remain in bales at least six months.

#### THE MANIPULATION AND PACKING OF SUMATRA TOBACCO.

When the tobacco is received from the plantation, it should immediately be taken from the package and divided into three grades, as follows: Light thin leaves; medium-weight leaves of medium color; and dark heavy leaves. Then it should be tied into small bundles of about 50 leaves to a bundle and put in bulks of from 3,000 to 5,000 pounds each. This division is made in order to give to each grade just the amount of curing needed. Keep the room in which these bulks are made at a temperature of 75°. This is done by means of steam pipes running through the building. Also have the pipes so arranged that the room can be filled with steam, thus making the air soft and moist. These bulks are to be watched, turned, and rebulked from time to time in the same manner as Cuban tobacco. There are no fixed rules by which this work can be done, as the condition and type of tobacco govern the work in all cases. Every effort should be made to sweat this tobacco to a finish with what moisture it has when received from the curing shed. This can be accomplished if the tobacco is delivered from the farm in a proper condition. This is especially true if the tobacco is light and thin, as but little heat is needed to finish its curing; but if the tobacco is heavy and gummy, it inevitably becomes necessary to use water to force the curing.

It is the experience of the packers that there is nothing more suicidal than to offer to the trade raw, uncured tobacco. It must be cured even at the expense of color, etc. Light tobacco is made in the field, not in the curing shed or packing house. Thin light tobacco will cure out thin and light. Heavy, gummy tobacco, though light in color when taken from the poles or curing shed, will be dark when sufficiently cured for use. It is often the case that tobacco which is thin, light, and very fine is delivered to the packer from the farm in an exceedingly dry condition. This tobacco must be softened; but to give it water is risky, whether the water is applied by dipping or by spraying. Even in using a very fine atomizer it will get water stains. The following method is therefore adopted:

After softening up a lot of low-grade goods pile in a great heap, and allow it to remain until it becomes very hot. Take this hot tobacco and make a bed about 5 feet wide, 10 feet long, and 1 foot thick; then lay a strip of paper about 12 inches wide across the end of the pile and begin bulking the dry tobacco. Allow the body of the leaves to lie on the paper and the head of the hand to rest on the hot tobacco, running rows across the bulk. Begin again, allowing the next layer to rest on the first with the heads of the hands pulled a little forward,

resting on the hot or wet tobacco. This is continued the entire length of the bulk. Then reverse the order, allowing the heads of the hands to point up, dropping each layer back so that about 5 inches of the head will show. This is continued until the full length of the bulk has been covered, leaving nothing exposed on the top but the heads of the hands, all tips and bodies of the leaves being in the center. Put on another thick layer of wet tobacco and the strip of paper, and bulk again as before. Continue this until the bulk reaches the height of 5 or 6 feet; then cover well with low-grade stuff and allow the bulk to remain five or six days, by which time the dry tobacco will have taken up sufficient moisture and heat from the wet tobacco to be ready for the assorters. In this way the possibility of water stains is avoided and the tobacco comes out soft and clean.

Proceed to assort in the following grades, making four sizes each: Light plain wrappers, light spotted wrappers, medium-colored plain wrappers, medium-colored spotted wrappers, dark plain wrappers, and dark spotted wrappers. Make the same number of grades in seconds. The seconds are leaves slightly broken and uneven in color. Thus we have twelve assortments of wrappers of four sizes each; in all, forty-eight grades. As in the handling of Cuban tobacco, there should be an inspector for each of these assortments, who will take great care that a proper assortment is made. The tobacco is then given to the foreman of the tiers, who has it tied in hands, putting thirty-five to forty leaves in each hand. It is again put in bulk, packing fan shaped—that is, the leaves when tied are folded once and the hand is carefully flattened. The bulks are narrow and so arranged that the tobacco will slowly age and dry out. When sufficiently dry, it is packed in matting just as is done in Sumatra. After finishing the wrapper grade take up the filler portion, giving it the same treatment as is given the Cuban tobacco, putting the sound leaves in carrots and stemming the lower grade for “book & fillers.” With this the work of the packer ends and the work of the salesman is in order (Pl. VIII, fig. 2).

#### DEVELOPMENT OF THE TOBACCO INDUSTRY IN FLORIDA.

The cultivation of tobacco in Florida is not a new industry, but an old one revived. Far back in the forties and fifties Gadsden County became famous for the fine wrapper leaf produced there. The industry thrived until the civil war, but from that time until 1888 the production of tobacco in Florida was so small that it attracted but little attention. In 1880 only about 90 acres were grown in the State; in 1890 the acreage had increased to more than 1,000 acres; and in 1898 there were at least 8,000 acres, giving a yield of 4,000,000 pounds. After the close of the war a few farmers continued to grow tobacco in a very small way, and they would often accumulate three or four crops before finding a buyer, and even then the price would be low. The farmers became



FIG. 1.—PUTTING UP THE CUBAN TOBACCO INTO CARROTS.

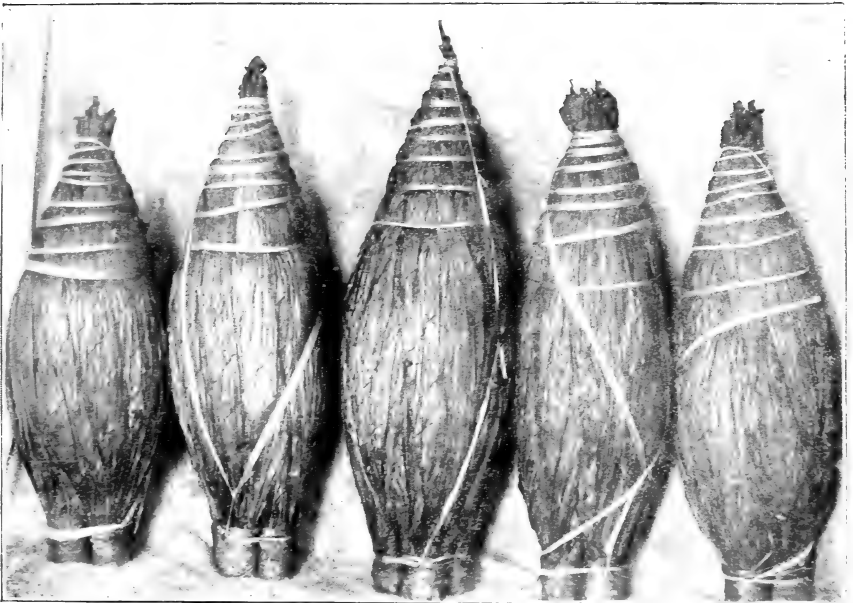

FIG. 2. SAMPLES OF THE HAITI AND HONDURAS CARROTS READY TO BE BALE.



discouraged and reduced their acreage, until, as before stated, in 1880 there was less than 100 acres planted in tobacco in the entire State.

“OLD FLORIDA” TOBACCO.

The variety of tobacco grown in Florida before the civil war, and especially famous for its beautifully spotted wrappers, was known simply as Florida tobacco, being unlike any type produced in any other part of the country. When the industry was revived in 1889 and 1890, many of the old planters had seed of what was known as “Old Florida,” which they again planted. But the style had changed; Sumatra, with its bright rich gloss, had established itself; “Old Florida” proved to be a back number and the farmers had to give it up. In the year 1884-85 several farmers of small plantations obtained seed from the island of Cuba and a number of small patches of it were grown. It was this tobacco that revived the industry. Some of the tobacco grown from the Cuban seed fell into the hands of a large cigar-manufacturing concern of New York, which made it into cigars. The quality of these cigars proved so satisfactory, that men were at once sent to Florida to study further the possibility of producing a tobacco that would meet the requirements of the trade. After going over the old tobacco sections of the State they became confident that the attempt could be made a success, and they purchased and equipped plantations in Gadsden County. This concern was followed by several other companies, all of which now own and operate large farms, each having established large and well-equipped packing houses in or near Quincy, the county seat of Gadsden County. These firms, in addition to the tobacco they grow, also buy extensively from local farmers.

EXPERIMENTS IN IMPROVING TOBACCO.

In order to improve the tobacco and adapt it to the trade demands, these concerns have indulged in all sorts of experiments, some of which have proved quite expensive. However, they have met with such a degree of success as to warrant them in continuing the experimental work. There were many questions to be settled. First of all, what seed should be used. To settle this question seed was obtained and tried from every part of the country. This point, however, was soon determined and now there are only two varieties grown in the State—Sumatra and Cuban—the Sumatra giving the style required for the wrapper and the Cuban giving the filler qualities nearest the requirements of the trade. As each of these tobaccos possesses the quality and style needed, the kind of soil best suited to each was the next point to be settled; then the proper fertilizer, the quantity necessary, and the proper cultivation had to be found out by numerous experiments. At first it was thought that but little fertilizer of any kind should be used. The tobacco was set out early, given a distance

in the drill of about 24 inches, and topped low; that is, not more than twelve or fourteen leaves were allowed to each stalk. The result was that the plants produced large, coarse, undesirable leaves. The next step was to give the tobacco less distance in the drill; 18 inches were tried. The result was better, but not satisfactory. From time to time changes were made until now the plant is given 14 inches, the fertilizer is doubled, and the tobacco is topped higher, allowing at least sixteen leaves to each stalk. The result is that the leaves are of the desirable size and finer in quality and appearance.

For a long time the cultivation was continued until the time of harvesting, but this was decidedly wrong. The writer has seen fields of tobacco plowed that were ripe and ready to be harvested, and in consequence the tobacco turned green and started a new growth. This generally increases the yield, but almost totally destroys the quality of the tobacco. At present the cultivation stops as soon as the plants are topped.

When the Sumatra seed was first introduced into Florida, the land selected, the amount of fertilizers used, and the methods of cultivation and harvesting employed were the same as those practiced in growing the Cuban variety. With this treatment Sumatra proved to be an absolute failure; many abandoned the seed, while others continued to experiment. It was soon found that the soil had to be exceedingly rich, the growth quick; that low topping was ruinous, and that each stalk should have from twenty-four to thirty leaves, according to the strength of the soil. When the land was exceedingly rich it was found best not to top at all, but to allow the plants to go to bloom. Then the leaves would be of desirable size, thin and smooth; whereas if topped, the leaves would curl and thicken. This tobacco is also crowded into the drill, the plants being given only from twelve to fourteen inches. The growth is rapid; the top leaves soon serve as a shade for the middle and lower leaves, and the results have been most gratifying. New land proved to be more desirable for this variety of tobacco, and it was noticed that when trees were left standing in the field the plants shaded by trees were far superior to the plants not so shaded. From this the idea of building artificial shade had its birth. It was also found that no good results could be obtained if the plants were cut, but the leaves should be primed off just as they ripen, and at a very early stage of ripeness.

#### CHANGES IN METHODS AND IMPROVEMENT IN STYLE AND QUALITY.

If we consider the tobacco industry in Florida during the past ten years, we will find great changes in the methods and improvements in the style and quality of the tobacco produced. Why were these changes in methods made? Because certain manufacturers knew just what the trade required. After the crop was harvested and cured they were able to discover its faults or good points, and if faults were found,



FIG. 1.—MAKING UP A BALE OF CUBAN TOBACCO.

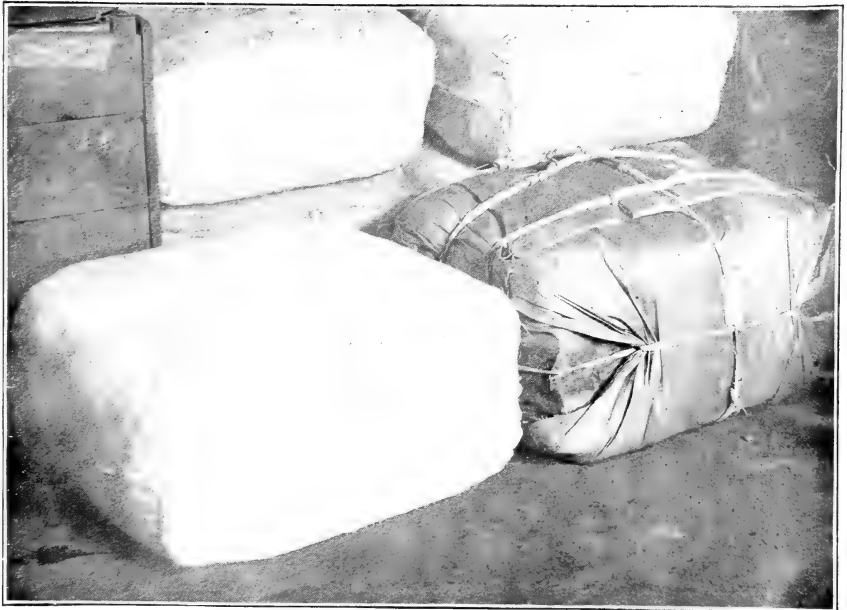

FIG. 2.—THE CUBAN BALE WITH AND WITHOUT THE CANVAS COVER.





they studied how to remedy them; if good points were observed, they studied to find how they were obtained. Each year there were a number of small experimental plots on which different kinds of soil were tested, different fertilizers used, and different methods of cultivation employed. The tobacco of each plot was harvested at different stages of growth—ripe, overripe, and underripe. In the curing shed this experiment was continued. If there were four experimental crops, they were cured in four different barns and a part of the tobacco from each plot put in each barn.

For convenience, we will call the four plots A, B, C, and D and the barns or curing sheds 1, 2, 3, and 4. In each barn we have tobacco from the four plots, and each barn receives different manipulation. The tobacco from each barn was marked so that it could be easily identified, and when thoroughly cured its quality was tested. It can be seen at once that such a method of experimenting is practicable. We will say that all of the tobacco in barn No. 2 made the best showing and that the tobacco from plot A was the most desirable. Therefore we would naturally assume that the soil, fertilizer, and method of cultivation of plot A was the best and the management of barn No. 2 was the nearest correct. We could also determine at what stage of ripeness the tobacco should be harvested in order to obtain the best results. This final test can not be made, however, until the tobacco has been carried through the process of fermentation and all the qualities of the leaf thoroughly developed.

#### COST OF GROWING TOBACCO IN FLORIDA.

The following figures will undoubtedly surprise many not acquainted with the growing of tobacco in Florida. The cost per pound of the tobacco produced will seem exceedingly high. However, the figures are in every way conservative, and the experience of the large growers of tobacco in Florida will not disprove their correctness. In the first place, in order to grow 100 acres of tobacco each year it is necessary to have a farm containing at least 500 acres, as it is not considered desirable to plant the same field in tobacco for more than two or three consecutive years. These lands should be planted in other crops or allowed to rest for three or four years; so every two or three years the locality of the tobacco fields should be changed. On this point all farmers (I mean successful farmers) do not agree. Still, it is the opinion and practice of a majority of the successful farmers to rotate their crops, tobacco being the main crop for which the plantation is equipped. The fields planted in tobacco should be followed by such other crop as will tend to improve rather than to impoverish the land. Usually corn is planted, and when giving the corn the last plowing the field is sown in cowpeas. The writer has known fields to be greatly improved by the planting of these crops where no fertilizers were used. As soon as the corn is harvested and the pea vines begin to die they should be

plowed under. After this has been done for two or three years the field is again ready for tobacco, and it has really gained in general fertility.

While it is the special purpose of the farm to grow tobacco, any concern operating such a farm will strive to produce corn, oats, hay, and all such produce as may be necessary to sustain the farm. The first thing is to carefully select the lands best suited for tobacco and to plant on these lands only such crops as will tend to improve the soil. Potatoes, sugar cane and the like should never be raised on tobacco lands, as they are very exhausting to the soil. Many farmers, as soon as they locate the lands on which they expect to grow tobacco, sow such fields in beggar weed and cockleburs, and as soon as a good growth of either of these weeds can be obtained it is plowed under. This tends to improve the land.

In the following figures it will be noted that no credit is given the farm for any other crop than tobacco, all cost being applied to the tobacco crop, because whatever else is grown is simply used to sustain the farm and assist in producing the tobacco. Feed for stock is charged against the first crop—January to June, six months—by which time the farm should have produced oats, millet, and such other forage as may be necessary to feed the stock.

*Cost of farm and buildings.*

500 acres of land.....	\$5,000.00
House for superintendent.....	500.00
House for assistant superintendent.....	250.00
20 tenement houses or cabins.....	1,000.00
10 barns, 36 by 96 feet.....	5,818.50
160,000 laths.....	320.00
Stables, cribs, and other outhouses.....	500.00
	<hr/>
Total cost of land and improvements.....	\$13,388.50

*Stock and implements.*

8 mules, at \$120 each.....	960.00
1 horse for superintendent.....	125.00
Wagons, harnesses, and implements.....	500.00
	<hr/>
Total cost of stock and implements.....	1,585.00
	<hr/>
Total.....	14,973.50
	<hr/> <hr/>

*Labor and general expenses.*

Superintendent, for twelve months.....	900.00
Assistant superintendent, twelve months.....	480.00
2 foremen, for twelve months.....	360.00
10 men laborers, for twelve months.....	1,560.00
15 men laborers, for six months.....	1,170.00
25 women, for six months.....	1,200.00
Feed for stock for six months.....	270.00

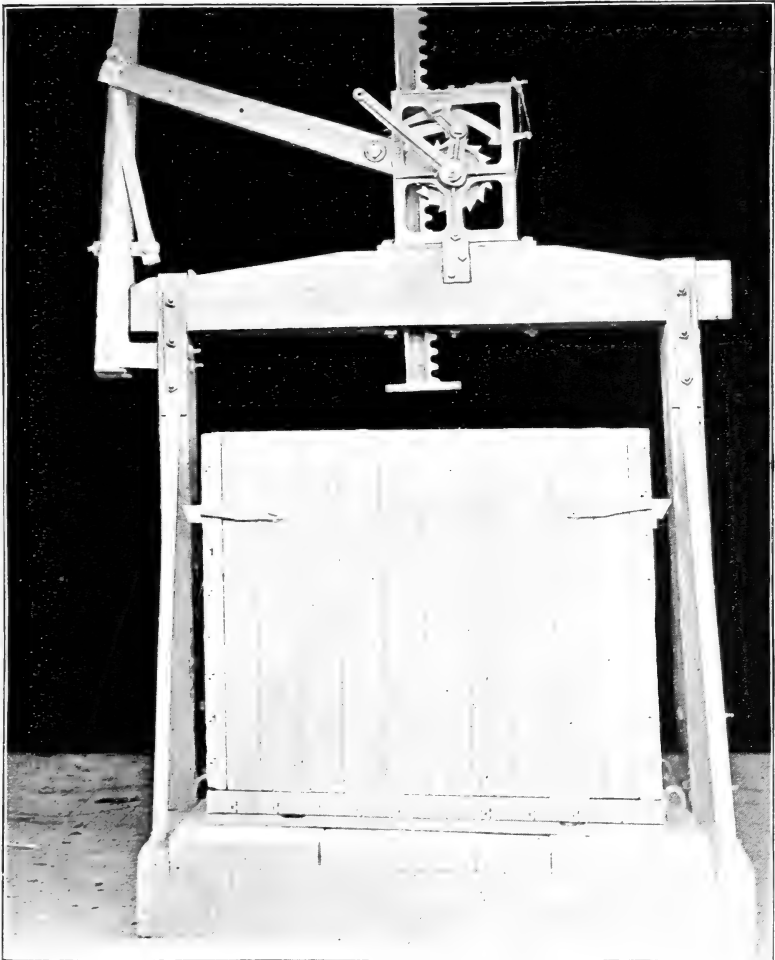

FIG. 1.—THE SAMPSON JACK-PRESS USED FOR MAKING THE SUMATRA BALE.



FIG. 2.—A FINISHED SUMATRA BALE OF FLORIDA-GROWN TOBACCO.



*Labor and general expenses—Continued.*

50 tons of cotton-seed meal .....	1,050.00
10,000 bushels of cotton seed.....	1,500.00
Incidental expenses.....	150.00
<hr/>	
Total amount of general expenses.....	8,640.00
Interest on \$8,640 for six months .....	259.20
Interest on \$14,973.50 for twelve months.....	898.41
10 per cent depreciation on land and improvements.....	1,338.85
20 per cent depreciation on stock and implements .....	317.00
<hr/>	
Amount chargeable to tobacco crops.....	11,453.46
Total amount of tobacco produced, 60,000 pounds.	
Average cost about 18½ cents per pound.	

## KIND OF BARN DESIRED AND ITS COST.

In the development of the tobacco industry in Florida one of the important points to be determined was, what kind of a barn or curing shed was most desirable. Different kinds of buildings were constructed—some broad and flat, others narrow and tall; some with wooden shutters, other with glass windows. The man in favor of the glass windows thought that to cure tobacco light in color, much light was necessary. This proved a failure, as light tobacco is grown and not made in the curing shed. The man with the tall, narrow barn thought

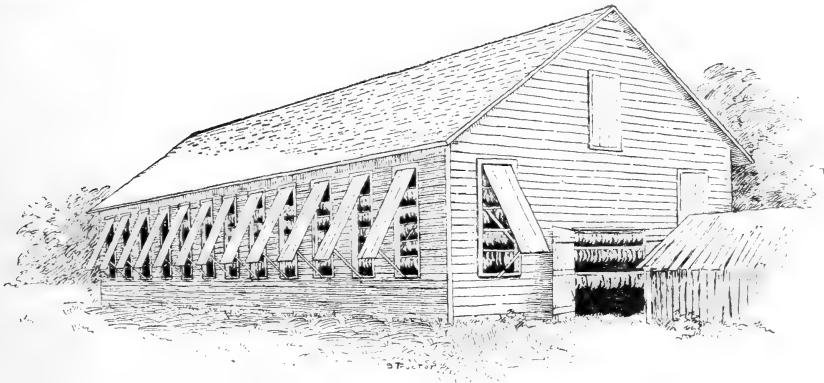

FIG. 2.—Shed filled with primed leaves with the ventilators open.

that to cure tobacco quickly was the proper thing; so he constructed his barn in such a way as to make it as hot as possible, in order to cure the tobacco quickly. The result was “house burn,” bad color, and dead tobacco. The man with the broad, flat barn wanted slow curing. This style of barn proved nearest to the proper barn. However, the idea of building a barn for slow curing was carried too far, the result being that the tobacco molded because of insufficient heat and ventilation. The barn illustrated in figs. 2-6 has been adopted by the most successful growers as the correct barn.

## ESTIMATES AND COST OF CONSTRUCTION OF BARN.

The following detailed estimates of the cost and quantity of material necessary for the construction of such a barn, together with the cost of labor, may be of interest:

*Estimate of material required for tobacco barn.*

	Feet.	
Sills, 22 pieces 6" x 6" x 20' .....	1,320	
Studding (24-inch centers), 160 pieces 2" x 4" x 18' .....	1,920	
Plates, 14 pieces 2" x 6" x 20' .....	280	
Rafters (26-inch centers), 88 pieces 3" x 6" x 24' .....	3,168	
Strongback for rafters, 6 pieces 3" x 6" x 32' .....	288	
Strongback supports, 14 pieces 3" x 6" x 8' .....	168	
Uprights for tiers, 10 pieces 4' x 4" x 21' .....	280	
Uprights for tiers, 10 pieces 4' x 4" x 24' .....	320	
Uprights for tiers, 10 pieces 4' x 4" x 27' .....	360	
Uprights for tiers, 10 pieces 4' x 4" x 30' .....	400	
Tier poles, 240 pieces 2" x 4' x 16' .....	2,560	
Ribbons, 56 pieces 1' x 4" x 20' .....	374	
Cross braces, 14 pieces 1' x 6" x 25' .....	175	
Ventilators, 16 pieces 1" x 12" x 12' .....	192	
Ventilators, 32 pieces 1" x 12" x 10' .....	320	
Sheathing for roof, 2,750 feet 1" x 3" x any .....	2,750	
Weatherboarding, 4,500 feet 1" x 6" x any .....	4,500	
Doors and shutters, 1,000 feet G. and T. ceiling .....	1,000	
	20,375, at \$10..	\$203.75
Pillars, 2,000 brick, at \$10 .....		20.00
Pillars, 2 barrels stone lime, at \$1.50 .....		3.00
Shingles (6-inch to weather), 30,000 4" x 18" cypress, at \$3 .....		90.00
Ventilators, 60 pairs 8-inch T hinges, at 12½ cents .....		7.50
Shutters, 22 pairs 8-inch strap hinges, at 15 cents .....		3.30
Doors, 8 pairs 12-inch strap hinges, at 20 cents .....		1.60
Shutter props, 11 pairs 6-inch T hinges, at 10 cents .....		1.10
Ventilator levers, 24 angle brackets, at 10 cents .....		2.40
Intermediate tiers for primed tobacco:		
5,200 feet barn wire .....		5.00
20 pounds staples .....		1.00
2 kegs 4-penny cut nails, at \$3 .....		6.00
3 kegs 10-penny cut nails, at \$2.50 .....		7.50
2 kegs 20-penny cut nails, at \$2.35 .....		4.70
Labor .....		225.00
Total cost of barn (without paint) .....		581.85

Building, 36 x 96; 16 feet from sills to plate tiers, 4 tiers; 13 feet from plate tiers to point of roof, 2 tiers. All the tiers are 4 feet apart each way. When tobacco is primed the tiers are doubled in quantity. This is done by stretching heavy wire so as to alternate with the original tiers.

There are years when the seasons are very unfavorable when the cost will naturally be increased, while during other years when the seasons are exceedingly favorable the cost is reduced. It will be noticed that the barn room provided for this 100 acres of tobacco is small. The writer is aware of the fact that if the entire acreage of

tobacco should ripen within one month the space would be altogether insufficient, but on such a farm harvesting should begin the middle of June and continue until the 1st of September, so each barn would be

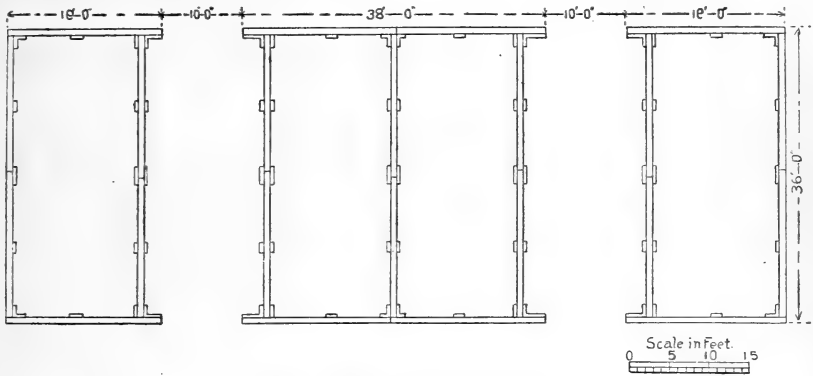

FIG. 3.—Ground plan of tobacco barn.

filled two or three times. In this way the barns would be quite sufficient.

#### TOBACCO GROWN BY THE FARMER COMPARED WITH THAT GROWN BY THE TOBACCO PLANTER.

If a farmer of a small tobacco farm is asked what it costs to raise tobacco in Florida, he will say from 10 to 12 cents per pound, according to the season. The explanation of this is, the farmer lays out his farm not for the sole purpose of growing tobacco, but for producing everything needful for the support of himself and family. Such a farmer may have in cultivation 100 acres, only 8 or 10 of which are in tobacco. His attention is given to producing corn, potatoes, peas, rice, and peanuts, and

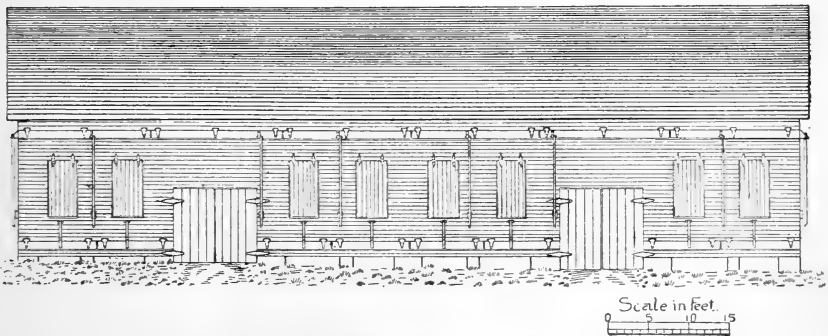

FIG. 4.—Side elevation of tobacco barn.

to the raising of hogs and cows—in fact, all things necessary for the sustenance of his family. As a money crop, he plants 10 acres in tobacco, against which he makes no charge for his own services or for

the services of any member of his family who may assist in its production. He simply counts the fertilizers used and the actual time his hired labor worked in the field; so with this method of calculation the actual cost of producing tobacco by anyone engaged in tobacco raising as a business would be greatly at variance with the figures given by a farmer.

The question then naturally arises, if the farmers can raise tobacco at 12 cents per pound and it costs the larger concerns from 18 to 20 cents per pound, why would it not be better for the large concerns to



FIG. 5.—End elevation of tobacco barn.

let the farmers grow all the tobacco and buy of them? The answer is this: The large concern that has sufficient capital to equip a farm and grow 100 acres of tobacco is also able to employ good men to manage the farm—men who give their entire time and attention to the growing and curing of the tobacco. This care begins with the first work on the farm and does not end until the tobacco is delivered to the packing houses, the tobacco receiving at all times the greatest care and attention. The superintendent and his assistant watch and study the tobacco closely and do all things necessary for its perfect development.



These large farms are owned by leaf dealers who have been long in the business, who know just what the trade wants, and who bend all their energies to secure it. There is no time at which the tobacco is neglected. The farmer with a small plantation may produce in the field fully as good a crop as is raised by the larger concern, but after the tobacco is taken from the stalks this farmer simply packs it in boxes of all sizes and kinds, places it in an open barn, and apparently forgets that he has any tobacco; that is, if one is to judge from the care and attention it receives. This is the weak point on the small

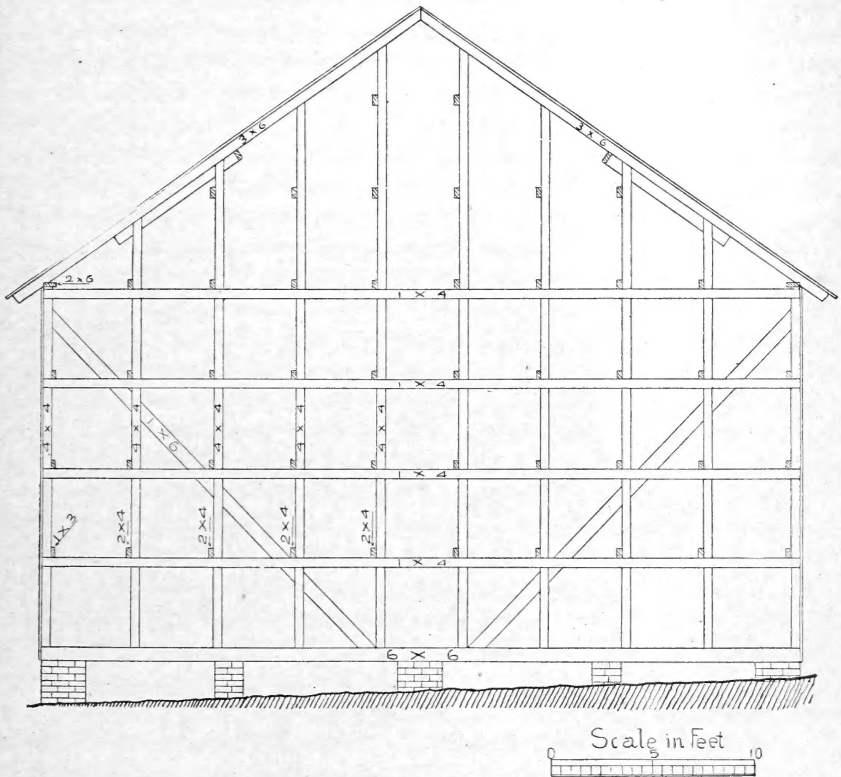

FIG. 6.—Middle section of tobacco barn.

tobacco farms, and success can never be attained until this point is remedied. A poor crop in the field must inevitably produce a poor finished article, although the tobacco may be improved or injured by proper or improper treatment after curing. A fine crop in the field is no guaranty that it will be fine and desirable when the buyer comes around, since in the absence of proper care it will become exceedingly poor and, in some cases, almost worthless. Of course, there are some farmers of small tobacco plantations who recognize these facts and who produce and market just as good tobacco each year as do the larger

growers, but they are the exception rather than the rule. Such men make a study of tobacco, and from them the larger growers obtain each year good and valuable points. The dealer who wishes to succeed becomes a farmer; he knows that while it may cost him more to produce the tobacco than to buy it from the small farms, it will be more profitable in the end, as he will then have what the market demands.

As has been previously stated, the manipulation of the barn is entirely governed by weather conditions. This much, at least, can be said—the barn should be so managed as to have the tobacco go in and out of case once in every twenty-four hours, care being taken not to allow the tobacco to become too damp or too dry. When this is done with care, the tobacco that is hung on the stalks will cure in about thirty days; that which is primed and strung will cure in about fifteen days. The present method of manipulating these tobaccos after they are pole-cured is quite different from what it was years ago. Then they simply took the tobacco from the poles, made it into three assortments—long wrappers, short wrappers, and fillers—and packed them into boxes, where they remained until a buyer came. When sold, the buyer had the case well closed and shipped just as it was. If the tobacco happened to sweat and cure out well in the case, all well and good; but if not, it did not seem to occur to the growers that any thing could have been done to insure good curing. To reach the present methods many expensive experiments were made. At first it was thought that only a slight curing was necessary, and the tobacco was baled raw. The trade found fault with this because the tobacco was rank. Then the fillers were thoroughly cured and all went well, the light wrapper—or so-called light wrapper—still being cured but little, as thorough curing would so darken the leaf that it could not pass for light. The result was that the Florida wrappers were condemned by the trade. The packers of Florida to-day will not offer to the trade tobacco that is not thoroughly cured. The outcome is that Florida wrappers are in demand at present, and the fillers from the Cuban seed bring the highest price of any filler tobacco produced in the United States. This is largely due to the methods of fermentation, as well as to the methods of cultivation.

The values of these different grades vary so greatly that any figures given would be merely conjectural, as the first wrappers will be valued at from \$1 to \$2.50, the seconds from 40 to 75 cents per pound, and the fillers from 30 to 45 cents per pound, so exact figures can not be given. Of course these prices refer to the tobacco baled and ready for the manufacturer. The prices paid the local farmers vary from 12 to 40 cents, according to the style and quality of the crop. Some years the farmers have lost money, while other years they have realized good prices and made fine profits. As a whole the farms of Gadsden County are in good condition and the farmers are prospering.

As already shown, the tobacco will cost the large grower, delivered at the packing houses, at least 18 cents per pound. This by no means ends the cost. The present methods of fermenting, assorting, classifying, and baling cost from 6 to 8 cents per pound, including cost of material, interest on money, insurance, etc. The tobacco will sustain a shrinkage in this process of work of at least 10 per cent, and often the shrinkage will reach 20 per cent from the time of delivery to the packing house to the time the tobacco is marketed, so that the final cost of the tobacco at the time of marketing can be estimated to be from 30 to 32 cents per pound. The following is about the result of an average Florida packing: Of a lot of 100,000 pounds there will be about 10 per cent first wrappers, 35 per cent second wrappers, 40 per cent of good clean fillers, and 15 per cent of trash and waste; or 10,000 pounds of first wrappers, 35,000 pounds of second wrappers, 40,000 pounds of filler, making in all 85,000 pounds, with a loss of 15,000 pounds. The point of interest now is, How can the per cent of upper-grade goods be increased? This must be solved by continuous experiments along the line from seed bed to bale.



