

UD  
413  
A3

UC-NRLF  
  
\$B 72 696

YC 63161

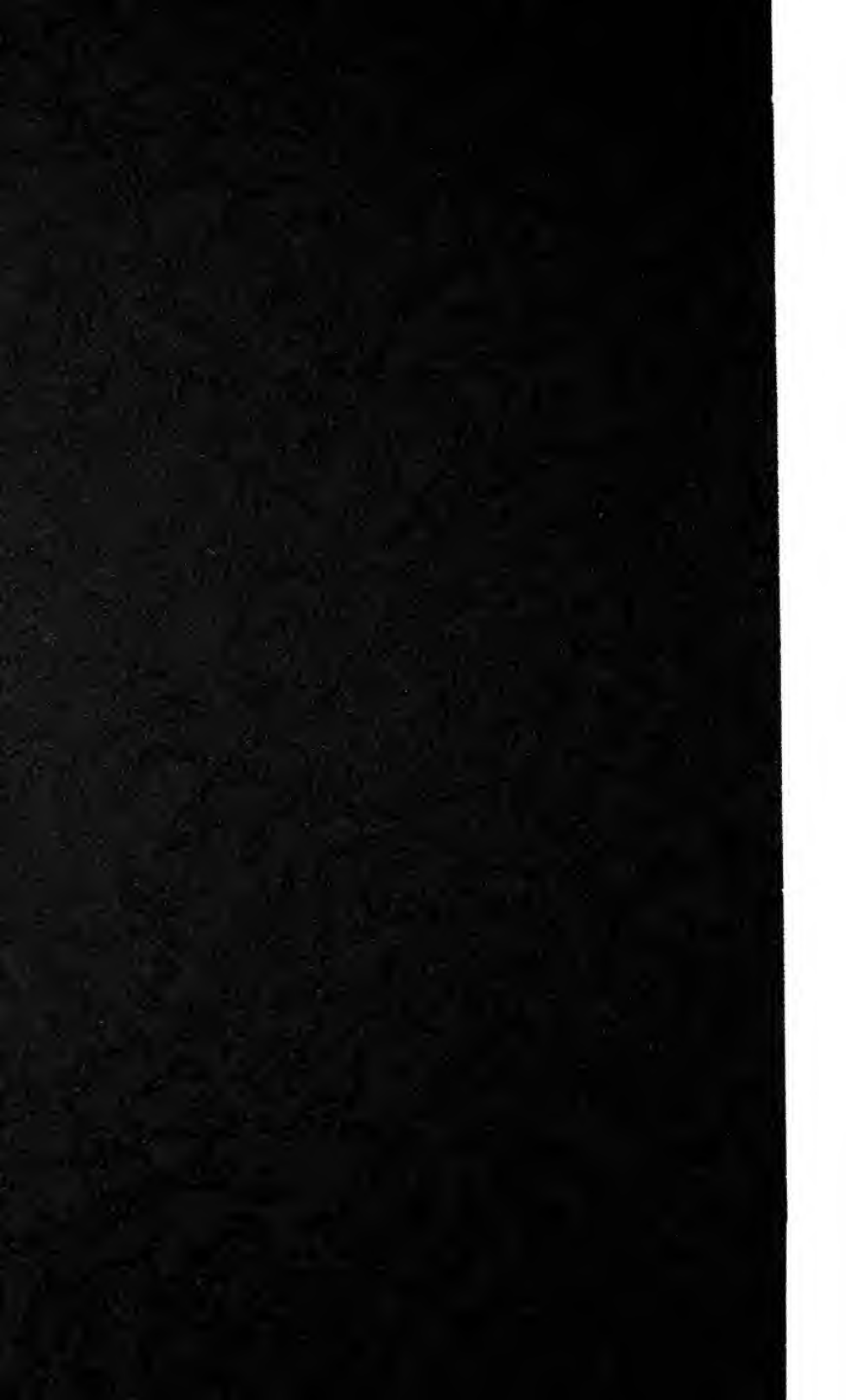

No. 1866

DESCRIPTION  
OF THE  
AUTOMATIC PISTOL, CALIBER .45  
MODEL OF 1911

WITH RULES FOR MANAGEMENT, MEMORANDA OF  
TRAJECTORY, AND DESCRIPTION  
OF AMMUNITION

(SIX PLATES)

APRIL 1, 1912  
REVISED FEBRUARY 14, 1914



WASHINGTON  
GOVERNMENT PRINTING OFFICE

1917

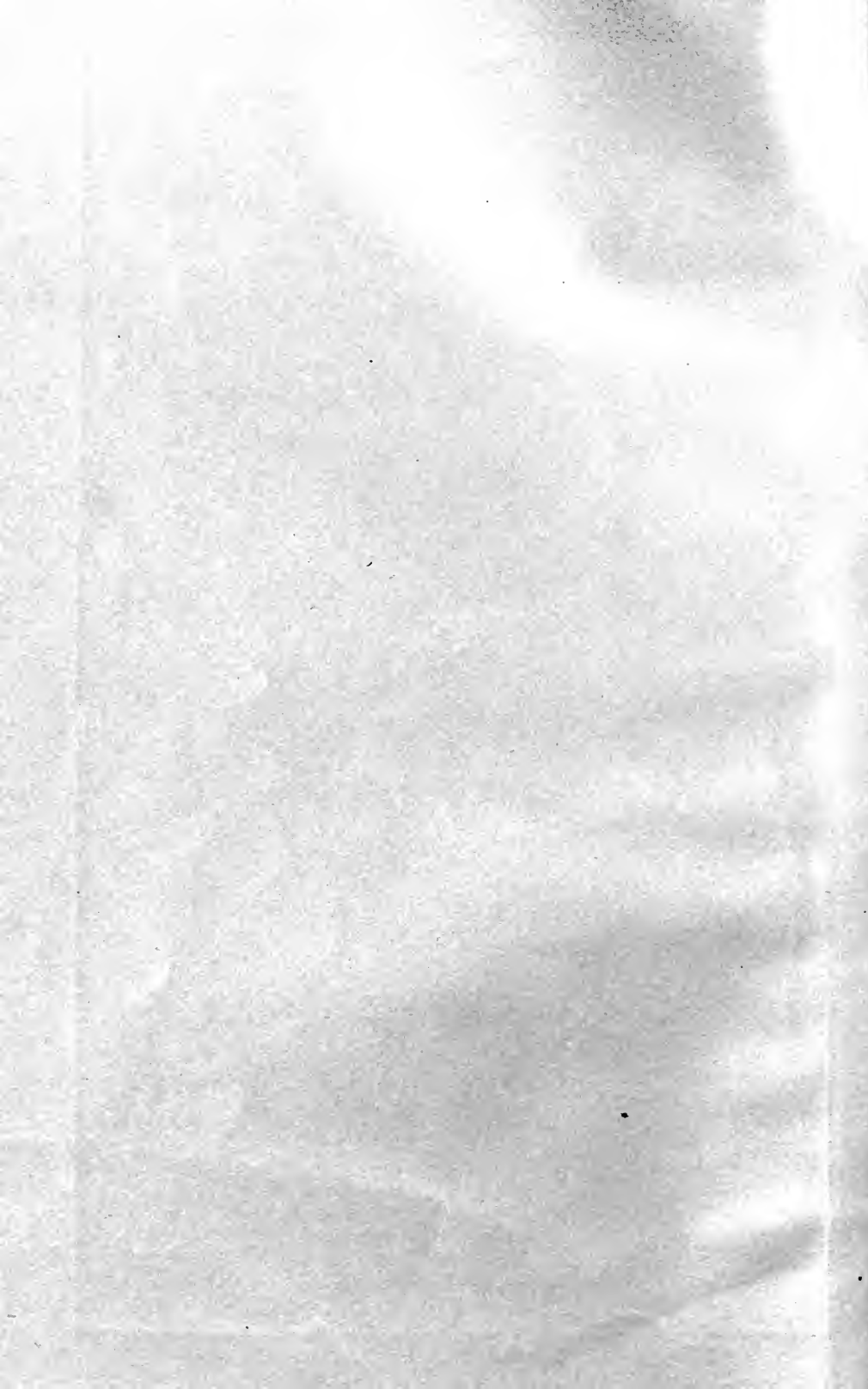

No. 1866

---

DESCRIPTION  
OF THE  
AUTOMATIC PISTOL, CALIBER .45  
MODEL OF 1911

WITH RULES FOR MANAGEMENT, MEMORANDA OF  
TRAJECTORY, AND DESCRIPTION  
OF AMMUNITION

---

(SIX PLATES)

---

APRIL 1, 1912  
REVISED FEBRUARY 14, 1914



WASHINGTON  
GOVERNMENT PRINTING OFFICE  
1917

UJ 413  
A三

UJ 413  
A三

WAR DEPARTMENT,  
OFFICE OF THE CHIEF OF ORDNANCE,  
*Washington, February 14, 1914.*

This Manual is published for the information and government of the Regular Army and Organized Militia of the United States.

By order of the Secretary of War:

WILLIAM CROZIER,  
*Brigadier General, Chief of Ordnance.*

(3)

Digitized by the Internet Archive  
in 2007 with funding from  
Microsoft Corporation



## CONTENTS.

---

	Page.
Component parts.....	7
Plates, list.....	7-8
Detailed description.....	8-11
To dismount and assemble.....	11-13
Method of operation.....	13
Safety devices.....	13-14
Operation in detail.....	14-16
Parts issued for repairs.....	16
Important points.....	16-17
Cleaning kit.....	17
Miscellaneous data.....	17
Exterior ballistics.....	18-19
Ammunition.....	19-20
Packing.....	20

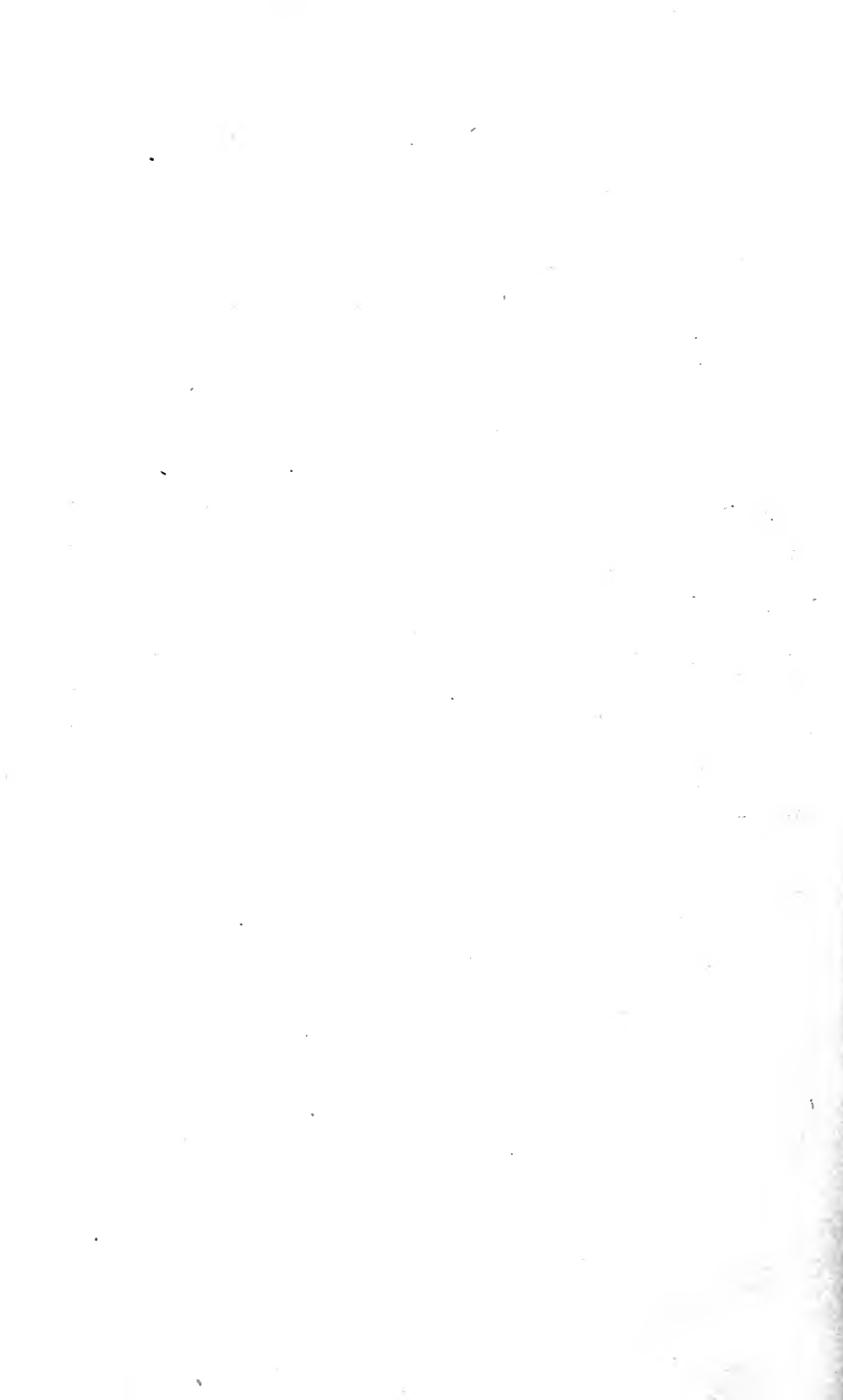

# DESCRIPTION OF THE AUTOMATIC PISTOL, CALIBER .45, MODEL OF 1911.

(6 plates.)

The automatic pistols, caliber .45, model of 1911, in the military service are marked on the right side, "Model of 1911, U. S. Army"; on the left side, "United States Property." They are also marked with the serial number of the pistol.

## COMPONENT PARTS.

- |                          |                             |
|--------------------------|-----------------------------|
| 1. Receiver.             | 28. Mainspring cap.         |
| 2. Barrel.               | 29. Mainspring-cap pin.     |
| 3. Slide.                | 30. Sear.                   |
| 4. Plunger tube.         | 31. Sear spring.            |
| 5. Slide-stop plunger.   | 32. Sear pin.               |
| 6. Plunger spring.       | 33. Disconnecter.           |
| 7. Safty-lock plunger.   | 34. Trigger.                |
| 8. Slide stop.           | 35. Grip safety.            |
| 9. Rear sight.           | 36. Safety lock.            |
| 10. Front sight.         | 37. Mainspring housing.     |
| 11. Link.                | 38. Housing pin.            |
| 12. Link pin.            | 39. Housing-pin retainer.   |
| 13. Barrel bushing.      | 40. Lanyard loop.           |
| 14. Recoil spring.       | 41. Lanyard-loop pin.       |
| 15. Recoil-spring guide. | 42. Magazine tube.          |
| 16. Plug.                | 43. Magazine base.          |
| 17. Extractor.           | 44. Magazine pins (2).      |
| 18. Ejector.             | 45. Magazine loop.          |
| 19. Ejector pin.         | 46. Magazine spring.        |
| 20. Firing pin.          | 47. Magazine follower.      |
| 21. Firing-pin spring.   | 48. Magazine catch.         |
| 22. Firing-pin stop.     | 49. Magazine-catch spring.  |
| 23. Hammer.              | 50. Magazine-catch lock.    |
| 24. Hammer pin.          | 51. Stocks, right and left. |
| 25. Hammer strut.        | 52. Stock screws (4).       |
| 26. Hammer-strut pin.    | 53. Screw bushings (4)      |
| 27. Mainspring.          |                             |

## PLATES.

Plate I is a side view of the pistol.

Plate II is a longitudinal section of the pistol, and shows the component parts in assembled position.

Plate III shows the receiver, barrel, and slide.

Plate IV shows the other component parts.

Plate V shows the magazine and its component parts.

Plate VI shows the cartridge and the trajectory.

In the plates the numbers correspond with those given in the list of component parts and in the description that follows.

#### DETAILED DESCRIPTION.

The three principal parts of the pistol are the receiver (1), barrel (2), and slide (3).

The *receiver* (1) has suitable guides for the reciprocating slide (3), and a hollow handle in which the magazine is inserted from below and locked in place by the magazine catch (48). The magazine may be removed by pressure upon the checkered end of the magazine catch (48), which projects from the left side of the receiver (1) in a convenient position for operation by the thumb.

The *magazine catch* (48) engages with and locks the magazine under the pressure of the *magazine catch spring* (49) and is held in the receiver (1) by means of the *magazine catch lock* (50).

The magazine consists of a *magazine tube* (42) closed at the bottom by means of the *magazine base* (43) secured with two *magazine pins* (44). The magazine base (43) has riveted to it the *magazine loop* (45) to which can be attached a lanyard to prevent loss of the magazine. Within the magazine tube (42) is contained the *magazine spring* (46) exerting a pressure against the *magazine follower* (47), which serves as a movable platform for the cartridges.

Secured at each end of the handle of receiver (1) on both sides are *screw bushings* (53), on to which are fitted the *stocks* (52) and into which, to secure the latter, are screwed the *stock screws* (52).

In front of the handle of receiver (1), in the trigger guard, is seated the *trigger* (34); in rear and above the handle the firing mechanism is arranged, comprising the *hammer* (23), mounted on the *hammer pin* (24), the *sear* (30) and (automatic) disconnector (33), mounted together on the *sear pin* (32), the grip safety (35), and safety lock (36); also the mainspring (27), and the sear spring (31). The *mainspring* (27) is seated within the *mainspring housing* (37) and there held by the *mainspring-cap pin* (29). The mainspring housing (37) also contains the *mainspring cap* (28) and the *housing-pin retainer* (39). The conical point of the latter protrudes slightly into the hole for the *housing pin* (38), engaging with the groove around the middle thereof, thereby holding the housing pin (38) in place. Into the base of the mainspring housing (37) is fitted the *lanyard loop* (40) secured by the *lanyard-loop pin* (41).

The *sear spring* (31) has a rib on its lower end which fits into a slot in the rear wall of the magazine seat and keeps the spring from moving vertically. The mainspring housing (37), bearing against

the rear of the spring, locks it in position and gives to it the required tension. The *hammer strut* (25) is attached to the hammer (23) in rear of its pivot by means of the *hammer-strut pin* (26). Its lower end rests in the mainspring cap (28).

Above the handle on the left side are the *slide stop plunger* (5) and *safety lock plunger* (7) with their ends protruding from the front and rear, respectively, of the *plunger tube* (4). The *plunger spring* (6) is seated between the plungers (5 and 7) within the plunger tube (4) and yieldingly holds them in position.

The *ejector* (18) is seated at the top of the receiver (1) near the rear end at the left side. It is held in place by the *ejector pin* (19).

The top of the receiver (1) forward of the trigger guard has a semitubular extension which forms the seat for the rear portion of the recoil spring (14).

The *barrel* (2) of the pistol is largest at the breech, and at the top has two transverse locking ribs, the forward edges of which, together with the forward edge of the breech portion, serve to positively interlock the barrel (2) with the slide (3) when in the firing position. At its rear is an extension which facilitates the entrance of the cartridge from the magazine into the chamber. The rear end of the barrel (2) is attached to the receiver (1) by the *link* (11), *link pin* (12), and the pin of the slide stop (8), and swinging thereon can move a limited distance lengthwise and also in a vertical plane.

The side walls of the slide (3) overlap the sides of the receiver (1), and being provided with longitudinal ribs corresponding with similar grooves at the top of the receiver (1), the slide (3) is free to move longitudinally.

The *slide* (3) has at its front end a strong tubular abutment which is in line with the forward portion of the receiver (1), and which permits the slide (3) to move to the rear until the rear end of the abutment comes in contact with the flange of the recoil spring guide (15) against the shoulder in the receiver (1) at its forward end, thereby positively limiting the rearward movement of the slide (3). The latter is therefore necessarily assembled to the receiver (1) from the front, and is prevented from being thrown rearward from the receiver (1) under any circumstances.

In the abutment at the front end of the slide (3) is seated the forward end of the *recoil spring* (14), fitted into the *plug* (16). The rear end of the recoil spring (14) fitted onto the *recoil spring guide* (15) rests against the shoulder in the front end of the receiver (1).

On the top of slide (3) are mounted the *front sight* (10) and *rear sight* (9):

The *barrel bushing* (13) fits into the front end of the slide (3), supports the muzzle end of the barrel (2), and holds the plug (16) and recoil spring (14) in place.

When the slide (3) and the barrel (2) therein are mounted upon the receiver (1) and the slide stop (8) is in its place, so that the pin part of the slide stop (8) locks the barrel (2) to the receiver (1) through the link (11), the slide (3) is thereby positively locked in place upon the receiver (1).

The *firing pin* (20), *firing-pin spring* (21), and (shell) *extractor* (17) are carried in the rear end of the slide (3) and locked by the *firing-pin stop* (22). By pressing the firing pin (20) forward so as to clear the firing-pin stop (22), the latter is released and may be removed downwardly, leaving both firing pin (20) and extractor (17) free for removal.

The *slide stop* (8) consists of the pin part, which serves as a pivot and passes through the link (11), and a body, on which is a thumb piece, for releasing the slide (3) from the open position.

The *safety lock* (36) consists of a thin plate, a projecting pin, a thumb piece, and a projecting stud. The pin part serves as a pivot for the safety lock (36) and is at the same time a pivot for the grip safety (35). The upper corner of the plate has an angle which will fit into a correspondingly shaped recess in the slide (3). When the slide (3) is in its forward position, and the hammer (23) is full cocked, the safety lock (36) may be pushed up manually, by means of the thumb piece, thereby positively locking the hammer and the slide. While the safety lock (36) is being pushed up into the locking position the stud on the safety lock (36) is being carried upward and it finally stands in rear of the lower arm of the sear (30), blocking the sear (30) and causing the locking of the hammer (23). If the safety lock (36) is pressed down so as to release the slide (3) the projecting stud on the safety lock (36) clears the sear (30), permitting the sear (30) to be operated by the trigger (34), thereby causing the release of the hammer (23) if the grip safety (35) is pressed inward, as by the hand grasping the handle of the pistol, and the trigger (34) is pulled.

The *grip safety* (35) is pivoted in the upper part of the receiver (1). Its lower part projects from the rear face of the handle under pressure of the short leaf of the sear spring (31), thereby locking the trigger whenever the handle of the pistol is released. But when the handle is grasped, as in the firing position, the grip safety (35) releases the trigger (34) without requiring the attention or thought of the firer.

The (automatic) *disconnecter* (33) is mounted in the receiver (1) in rear of the magazine seat. In the underside of the slide (3) and near its rear end, a recess is provided which stands above the top of the disconnecter (33) when the slide (3) is in the forward firing position. With the slide in this position the disconnecter (33) is raised to its operative position by the center leaf of the sear spring

(31) and it then will transmit the movement of the trigger (34) to the sear (30). The forward surfaces of the recess of the slide (3) and of the projecting end of the disconnecter (33) are inclining, so that the rearward movement of the slide (3) depresses the connector (33) until the slide (3) again returns to its forward position. In this depressed position of the disconnecter (33) the trigger (34) is disconnected from the sear (30), allowing the sear (30) to reengage the hammer (23). This arrangement automatically and positively prevents firing of the pistol except when all its parts are in the fully closed and locked firing position, and it also prevents more than one shot from following each pull of the trigger (34).

#### TO DISMOUNT AND ASSEMBLE THE PISTOL.

Remove the magazine by pressing the magazine catch (48).

Press the plug (16) inward and turn the barrel bushing (13) to the right until the plug (16) and the end of the recoil spring (14) protrude from their seat, releasing the tension of the spring (14). As the plug (16) is allowed to protrude from its seat, the finger or thumb should be kept over it, so that it will not jump away and be lost or strike the operator. Draw the slide (3) rearward until the smaller rear recess in its lower left edge stands above the projection on the thumb piece of the slide stop (8); press gently against the end of the pin of the slide stop (8) which protrudes from the right side of the receiver (1) above the trigger guard and remove the slide stop (8).

This releases the link (11), allowing the barrel (2), with the link (11) and the slide (3), to be drawn forward together from the receiver (1), carrying with them the barrel bushing (13), recoil spring (14), plug (16), and recoil-spring guide (15).

Remove these parts from the slide (3) by withdrawing the recoil-spring guide (15) from the rear of the recoil spring (14), and drawing the plug (16) and the recoil spring (14) forward from the slide (3). Turn plug (16) to right to remove from recoil spring (14). Turn the barrel bushing (13) to the left until it may be drawn forward from the slide (3). This releases the barrel (2) which, with the link (11), may be drawn forward from the slide (3), and by pushing out the link pin (12) the link (11) is released from the barrel (2).

Press the rear end of the firing pin (20) forward until it clears the firing-pin stop (22), which is then drawn downward from its seat in the slide (3); the firing pin (20), firing-pin spring (21), and extractor (17) are then removed from the rear of the slide (3).

The safety lock (36) is readily withdrawn from the receiver (1) by cocking the hammer (23) and pushing from the right on the pin part or pulling outward on the thumb piece of the safety lock (36)

when it is midway between its upper and lower positions. The cocked hammer (23) is then lowered and removed after removing the hammer pin (24) from the left side of the receiver (1). The housing pin (38) is then pushed out from the right side of the receiver (1), which allows the mainspring housing (37) to be withdrawn downward and the grip safety (35) rearward from the handle. The sear spring (31) may then be removed. By pushing out the sear pin (32) from the right to the left side of the receiver (1), the sear (30) and the disconnecter (33) are released.

To remove the mainspring (27), mainspring cap (28), and housing-pin retainer (39) from the mainspring housing (37), compress the mainspring (27) and push out the small mainspring cap pin (29).

To remove the magazine catch (48) from the receiver (1), its checkered left end must be pressed inward, when the right end of the magazine catch (48) will project so far from the right side of the receiver (1) that it may be rotated one-half turn. This movement will release the magazine catch lock (50) from its seat in the receiver (1), when the magazine catch (48), the magazine catch lock (50), and the magazine catch spring (49) may be removed.

With the improved design of magazine catch lock (50) the operation of dismounting the magazine catch (48) is simplified in that when the magazine catch (48) has been pressed inward the magazine catch lock (50) is turned by means of a screw driver or the short leaf of the sear spring (31) a quarter turn to the left when the magazine catch (48) with its contents can be removed. The improved design will be recognized from the fact that the head of the magazine catch lock (50) is slotted.

The trigger (34) can then be removed rearwardly from the receiver (1).

The hammer strut (25) or the long arm of the screw driver can be used to push out all the pins except the mainspring-cap pin (29) lanyard-loop pin (41), and ejector pin (19).

To assemble the pistol, proceed in the reverse order.

It should be noted that the disconnecter (33) and sear (30) are assembled as follows: Place the cylindrical part of the disconnecter (33) in its hole in the receiver (1) with the flat face of the lower part of the disconnecter (33) resting against the yoke of the trigger (34). Then place the sear (30), lugs downward, so that it straddles the disconnecter (33). The sear pin (32) is then inserted in place, so that it passes through both the disconnecter (33) and the sear (30).

The sear (30), disconnecter (33), and hammer (23) being in place and the hammer (23) down, to replace the sear spring (31), locate its lower end in the cut in the receiver (1), with the end of the long leaf resting on the sear (30); then insert the mainspring housing (37)



until its lower end projects below the frame about one-eighth of an inch, replace the grip safety (35), cock the hammer (23), and replace the safety lock (36); then lower the cocked hammer (23), push the mainspring housing (37) home and insert the housing pin (38).

In assembling the safety lock (36) to the receiver (1) use the tip of the magazine follower (47) or the screw driver to press the safety-lock plunger (7) home, thus allowing the seating of the safety lock (36). It should be remembered that when assembling the safety lock (36) the hammer (23) must be cocked.

When replacing the slide (3) and barrel (2) on the receiver (1), care must be taken that the link (11) is tilted forward as far as possible and that the link pin (12) is in place.

#### METHOD OF OPERATION.

A loaded magazine is placed in the handle and the slide (3) drawn fully back and released, thus bringing the first cartridge into the chamber (if the slide is open, push down the slide stop (8) to let the slide (3) go forward). The hammer (23) is thus cocked and the pistol is ready for firing.

If it is desired to make the pistol ready for instant use and for firing with the least possible delay the maximum number of shots, draw back the slide (3), insert a cartridge by hand into the chamber of the barrel (2), allow the slide (3) to close, then lock the slide (3) and the cocked hammer (23) by pressing the safety lock (36) upward, and insert a loaded magazine. The slide (3) and hammer (23) being thus positively locked, the pistol may be carried safely at full cock, and it is only necessary to press down the safety lock (36) (which is located within easy reach of the thumb) when raising the pistol to the firing position.

The grip safety (35) is provided with an extending horn, which not only serves as a guard to prevent the hand of the shooter from slipping upward and being struck or injured by the hammer (23), but also aids in accurate shooting by keeping the hand in the same position for each shot; and, furthermore, permits the lowering of the cocked hammer (23) with one hand by automatically pressing in the grip safety (35) when the hammer (23) is drawn slightly beyond the cocked position. In order to release the hammer (23), the grip safety (35) must be pressed in before the trigger (34) is pulled.

#### SAFETY DEVICES.

It is impossible for the firing pin (20) to discharge or even touch the primer, except on receiving the full blow of the hammer (23).

The pistol is provided with two automatic safety devices:

(1) The (automatic) disconnecter (33) which positively prevents the release of the hammer (23) unless the slide (3) and barrel (2)

are in the forward position and safely interlocked; this device also controls the firing and prevents more than one shot from following each pull of the trigger (34).

(2) The (automatic) grip safety (35) at all times locks the trigger (34) unless the handle is firmly grasped and the grip safety (35) pressed in.

The pistol is in addition provided with a safety lock (36) by which the closed slide (3) and the cocked hammer (23) can be at will positively locked in position.

#### OPERATION IN DETAIL.

The magazine may be charged with any number of cartridges from one to seven.

The charged magazine is inserted in the handle and the slide (3) drawn once to the rear. This movement cocks the hammer (23), compresses the recoil spring (14), and, when the slide (3) reaches the rear position, the magazine follower (47) raises the upper cartridge into the path of the slide (3). The slide (3) is then released and, being forced forward by the recoil spring (14), carries the first cartridge into the chamber of the barrel (2). As the slide (3) approaches its forward position, it encounters the rear extension of the barrel (2) and forces the barrel forward; the rear end of the barrel (2) swings upward on the link (11), turning on the muzzle end as on a fulcrum. When the slide (3) and barrel (2) reach their forward position they are positively locked together by the locking ribs on the barrel (2) and their joint forward movement is arrested by the barrel lug encountering the pin on the slide stop (8).

The pistol is then ready for firing.

When the hammer (23) is cocked, the hammer strut (25) moves downward, compressing the mainspring (27), and the sear (30), under action of the long leaf of the sear spring (31), engages its nose in the notch on the hammer (23).

In order that the pistol may be fired the following conditions must exist: The grip safety (35) must be pressed in, leaving the trigger (34) free to move; the slide (3) must be in its forward position, properly interlocked with the barrel (2), so that the disconnecter (33) is held in the recess on the underside of the slide (3) under the action of the sear spring (31), transmitting in this position any motion of the trigger (34) to the sear (30); the safety lock (36) must be down, in the unlocked position, so that the sear (30) will be unblocked and free to release the hammer (23) and the slide will be free to move back.

On pulling the trigger (34), the sear (30) is moved and the released hammer (23) strikes the firing pin (20) which transmits the blow to the primer of the cartridge. The pressure of the gases generated in

the barrel (2), by the explosion of the powder in the cartridge, is exerted in a forward direction against the bullet, driving it through the bore, and in a rearward direction against the face of the slide (3), driving the latter and the barrel (2) to the rear together. The downward swinging movement of the barrel (2) unlocks it from the slide (3), and the barrel (2) is then stopped in its lowest position. The slide (3) continues to move to the rear, opening the breech, cocking the hammer (23), extracting and ejecting the empty shell and compressing the recoil spring (14), until it—the slide (3)—reaches its rearmost position when another cartridge is raised in front of it and forced into the chamber of the barrel (2) by the return movement of the slide (3) under pressure of the recoil spring (14).

The weight and consequently the inertia of the slide (3), augmented by those of the barrel (2) are so many times greater than the weight and inertia of the bullet that the latter has been given its maximum velocity and has been driven from the muzzle of the barrel (2) before the slide (3) and barrel (2) have recoiled to the point where the barrel (2) commences its unlocking movement. This construction, therefore, delays the opening of the breech of the barrel (2) until after the bullet has left the muzzle and therefore practically prevents the escape of any of the powder gases to the rear after the breech has been opened.

This factor of safety is further increased by the tension of the recoil spring (14) and mainspring (27), both of which oppose the rearward movement of the slide (3).

While the comparatively great weight of the slide (3) of this pistol insures safety against premature opening of the breech, it also insures operation of the pistol, because at the point of the rearward opening movement where the barrel (2) is unlocked and stopped, the heavy slide (3) has attained a momentum which is sufficient to carry it through its complete opening movement and makes the pistol ready for another shot.

When the magazine has been emptied, the pawl-shaped slide stop (8) will be raised by the magazine follower (47) under action of the magazine spring (46) into the front recess on the lower left side of the slide (3), thereby locking the slide (3) in the open position, and serving as an indicator to remind the shooter that the empty magazine must be replaced by a charged one before the firing can be continued.

Pressure upon the magazine catch (48) quickly releases the empty magazine from the handle and permits the insertion of a loaded magazine.

To release the slide (3) from the open position, it is only necessary to press upon the thumb piece of the slide stop (8) when the slide (3) will go forward to its closed position, carrying a cartridge from

the previously inserted magazine into the barrel (2) and making the pistol ready for firing again.

#### PARTS ISSUED FOR REPAIRS.

For making repairs to these pistols in the hands of troops in field and garrison the following spare parts will be issued. The number opposite each part is the maximum for 100 pistols for ordinary repairs per year:

Name of component part.	Number.	Name of component part.	Number.
Disconnecter.....	5	Mainspring-cap pin.....	5
Extractor.....	10	Plug.....	5
Firing pin.....	10	Plunger spring.....	10
Firing-pin spring.....	10	Recoil spring.....	10
Firing-pin stop.....	5	Recoil-spring guide.....	5
Hammer pin.....	10	Safety-lock plunger.....	10
Hammer strut.....	10	Sear.....	10
Hammer-strut pin.....	10	Sear pin.....	5
Housing pin.....	10	Sear spring.....	10
Housing-pin retainer.....	5	Slide stop.....	5
Link.....	10	Slide-stop plunger.....	10
Link pin.....	10	Stock, left.....	5
Mainspring.....	5	Stock, right.....	5
Mainspring cap.....	5	Stock screw.....	10

#### IMPORTANT POINTS.

1. Never place the trigger finger within the trigger guard until it is intended to fire and the pistol is pointed toward the target.

2. Do not carry the pistol in the holster with the hammer cocked and safety lock on, except in an emergency.

If the pistol is so carried in the holster, cocked and safety lock on, the butt of the pistol should be rotated away from the body when withdrawing the pistol from the holster, in order to avoid displacing the safety lock.

3. The trigger should be pulled with the forefinger. If the trigger is pulled with the second finger, the forefinger extending along the side of the receiver is apt to press against the projecting pin of the slide stop and cause a jam when the slide recoils.

4. Care must be exercised in inserting the magazine to insure its engaging with the magazine catch.

5. Pressure must be entirely relieved from the trigger after each shot in order that the trigger may reengage with the sear.

6. To remove cartridges not fired disengage the magazine slightly and then extract the cartridge in the barrel by drawing back the slide.

7. The pistol must be kept clean, free from rust, and properly oiled. Excessive oil left in the mechanism will cause the parts to gum and work stiffly.

8. Care must be exercised to insure that the disconnecter is properly assembled to the sear.

9. The hammer should not be snapped when the pistol is partially disassembled.

10. The stocks need never be removed, as the pistol can be dismounted and assembled without removing them.

11. **Use no hammer either in assembling or dismantling the pistol.**

12. Magazine: Reasonable care should be taken to see that the magazine is not dented or otherwise damaged.

Never insert the magazine and strike it smartly with the hand to force it home, as this may spring the base or the inturning lips at the top. It should be inserted by a quick continuous movement.

#### CLEANING KIT.

For cleaning, dismantling, and assembling the pistol a kit is issued consisting of a metal box containing the following articles:

10 screw drivers.

10 cleaning rods, brass (made so that either a cloth wiper or bristle brush can be used).

10 thong brushes.

1 oil can.

1 grease pot for cosmic.

The above articles, with the exception of the oil can and grease pot for cosmic, are also supplied as part of the contents of the arm repair chest, model of 1910, when this chest is issued to organizations equipped with the pistol. The cleaning kit will therefore be issued only to organizations equipped with the pistol and not provided with an arm repair chest.

#### MISCELLANEOUS DATA CONCERNING PISTOL.

Weight, 2 pounds 7 ounces.

Trigger pull, 6 to  $7\frac{1}{2}$  pounds.

Total length, 8.593 inches.

Barrel:

Length, 5.025 inches.

Diameter of bore, 0.445 inch.

Rifling:

Grooves—

Number, 6.

Width, 0.1522 inch.

Depth, 0.003 inch.

Lands, width, 0.072 inch.

Twist, one turn in 16 inches, left-handed.

Front sight above axis of bore, 0.5597 inch.

## EXTERIOR BALLISTICS.

## 1. RAPIDITY OF FIRE.

(a) This pistol has been fired 21 times in 12 seconds, beginning with pistol empty and loaded magazines on a table at side of operator.

(b) Firing at 25 yards distance at a target 6 feet by 2 feet under the same conditions as in (a) 21 shots were fired in 28 seconds, making 21 hits, with a mean radius of 5.85 inches.

(c) Firing 10 shots, using a muzzle rest at 25 yards distance, at a target 6 feet by 2 feet, a mean radius of dispersion of 0.855 inch has been obtained.

## 2. ACCURACY WITH MUZZLE REST.

Range.	Mean radius.	Mean vertical deviation.
<i>Yards.</i>	<i>Inches.</i>	<i>Inches.</i>
25	0.855	0.619
50	1.356	.910
75	2.244	1.422

The above figures represent the mean variations for several targets.

## 3. DRIFT.

The drift or deviation due to the rifling is, in this pistol, to the left, but is more than neutralized by the pull of the trigger when the pistol is fired from the right hand. The drift is slight at short ranges and that for long ranges is immaterial, inasmuch as the pistol is a short-range weapon.

## 4. VELOCITY WITH STRIKING ENERGY.

Range.	Velocity.	Energy.
<i>Yards.</i>	<i>Feet per second.</i>	<i>Foot-pounds.</i>
0	802	329
25	788	317
50	773	305
75	758	294
100	744	283
125	730	272
150	717	262
175	704	253
200	691	244
225	678	235
250	666	226

## 5. PENETRATION IN WHITE PINE.

Range.	Depth.
<i>Yards.</i>	<i>Inches.</i>
25	6.0
50	5.8
75	5.6
100	5.5
150	5.2
200	4.6
250	4.0

A penetration of 1 inch in white pine corresponds to a dangerous wound.

The penetration in moist loam at 25 yards is 9.95 inches.

The penetration in dry sand at 25 yards is 7.8 inches.

## 6. TRAJECTORY.

Plate VI shows the trajectory with ammunition model of 1911 up to 250 yards. The maximum ordinate for this range is 4.29 feet at 126 yards from the muzzle. The trajectory is very flat up to 75 yards, at which range the pistol is accurate. The angle of departure is  $1^{\circ}-13'-37''$ .

With the angle of departure equal to  $45^{\circ}$ , the range is approximately 1,955 yards, the maximum ordinate of the trajectory being 2,219 feet.

### AMMUNITION FOR AUTOMATIC PISTOL CALIBER .45, MODEL OF 1911—BALL CARTRIDGE.

(Plate VI.)

The components of the ball cartridge consist of cartridge case, primer, powder, and bullet.

#### CARTRIDGE CASE.

The cartridge case is cylindrical and is made of brass. It is provided with a cannellure to prevent the bullet being forced down on the powder.

#### PRIMER.

The primer consists of a cup which contains the primer composition, a paper disk, and an anvil which resists the blow of the firing pin. The anvil is provided with two vents by which the flame is communicated to the charge. Ignition is produced by crushing the composition between the cup and anvil by a blow of the firing pin.

#### POWDER.

The powder is a smokeless powder. The charge varies with the kind and lot, but it is generally about 5 grains.

## BULLET.

The body of the bullet is a cylinder. The bullet has a core of lead and tin composition inclosed in a jacket of gilding metal or cupro-nickel. It weighs  $230 \pm 2$  grains.

	Inches.
Length of bullet.....	0.662
Diameter of cylindrical part of bullet.....	.45015
Total length of cartridge.....	1.261

To render the cartridge waterproof the inside of the neck of the case and the outside of the primer are shellacked.

## PACKING.

The cartridges are packed in pasteboard boxes containing 20 cartridges each. One hundred pasteboard boxes, or 2,000 cartridges are packed in one zinc case, hermetically sealed, with handle for tearing open. The whole is inclosed in a wooden box, the cover of which is fastened with screw hooks and thumb nuts and sealed.

	Pounds.
Weight of 100 cartridges.....	4.6
Weight of 2,000 cartridges, packed.....	110

WAR DEPARTMENT,

OFFICE OF THE CHIEF OF ORDNANCE,

*Washington, February 14, 1914.*

13092—2873.

April 1, 1912.

Revised, February 14, 1914.

FORM No. 1866.

Ed. June 13-17—20,000.





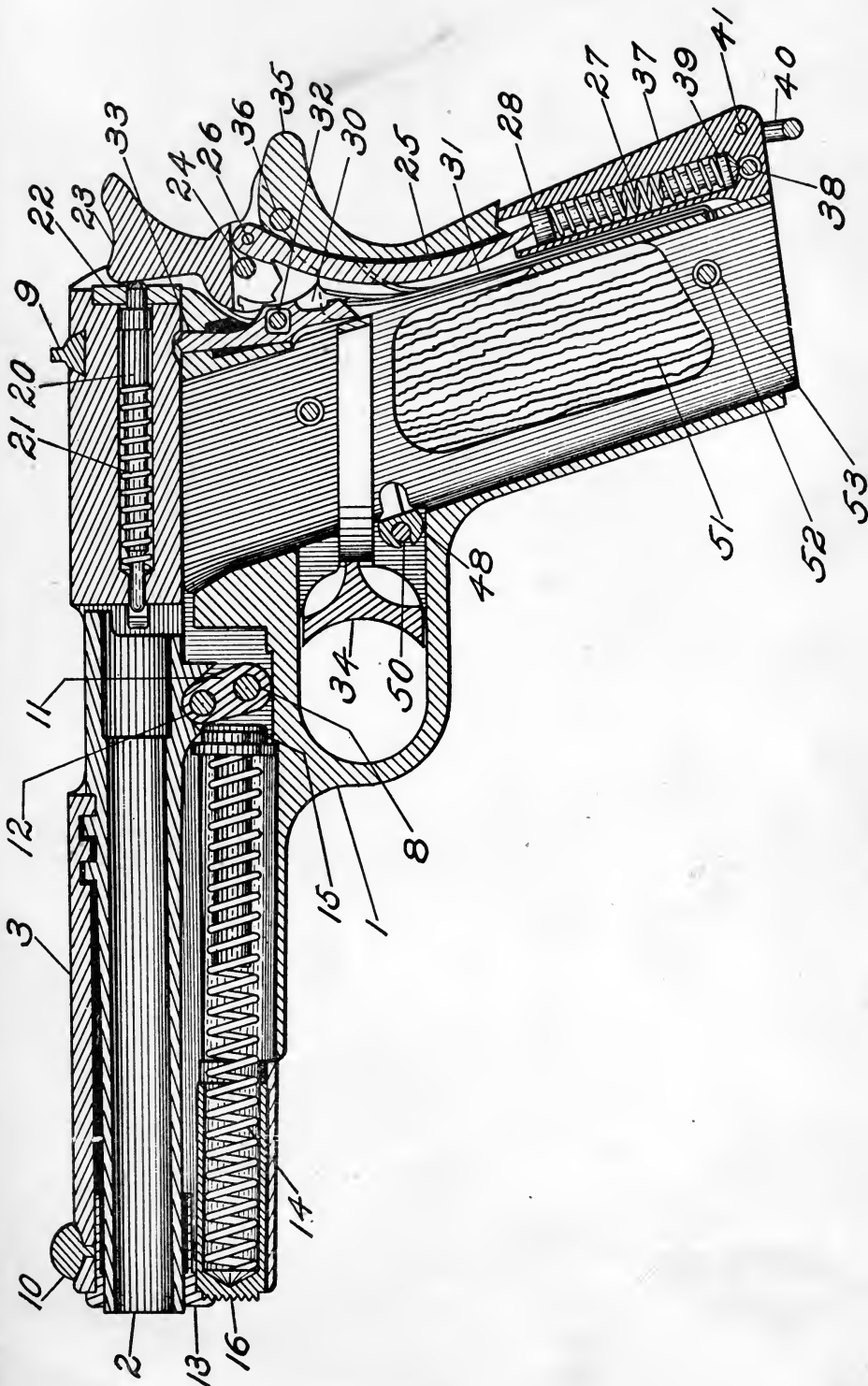





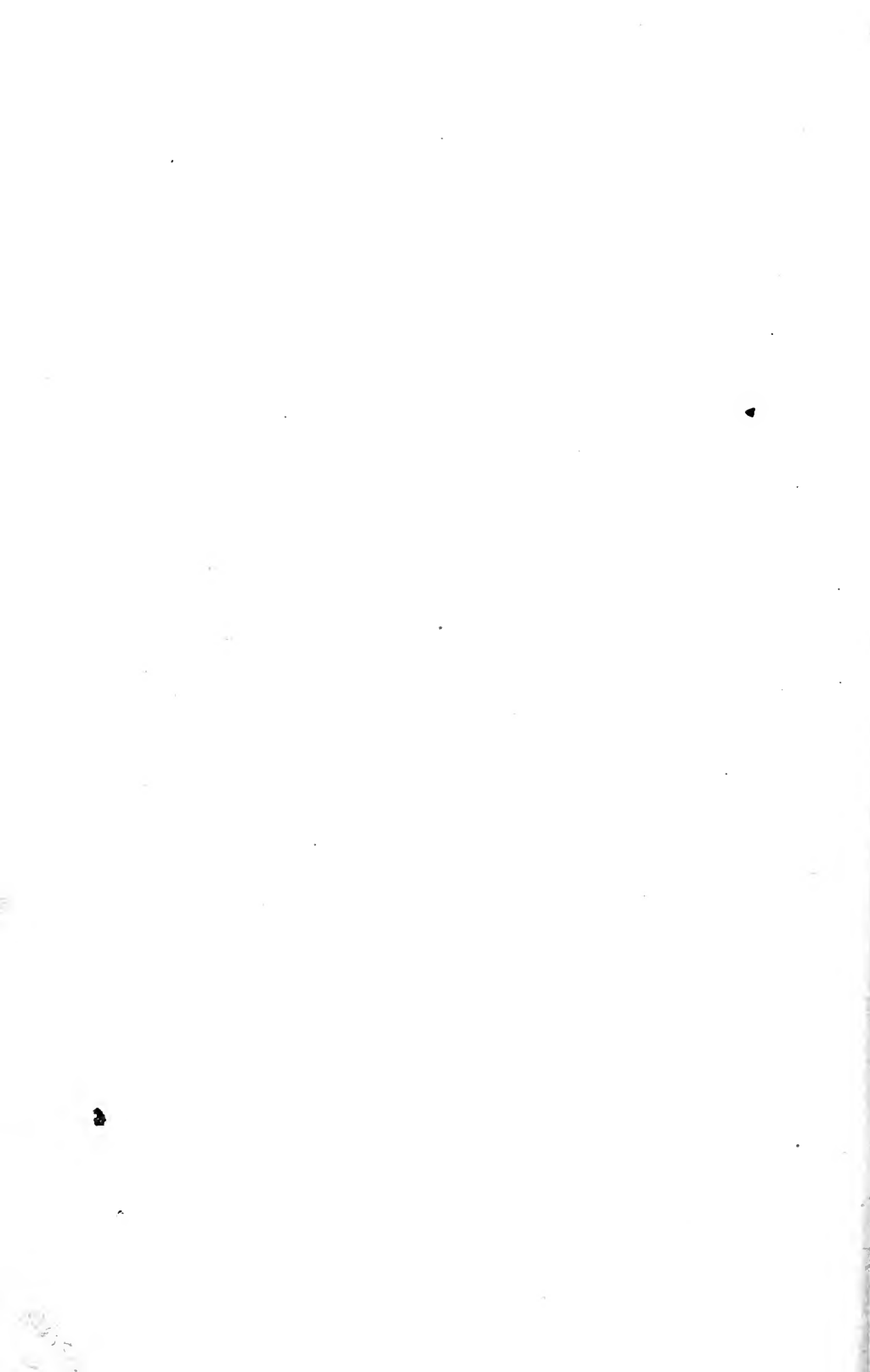

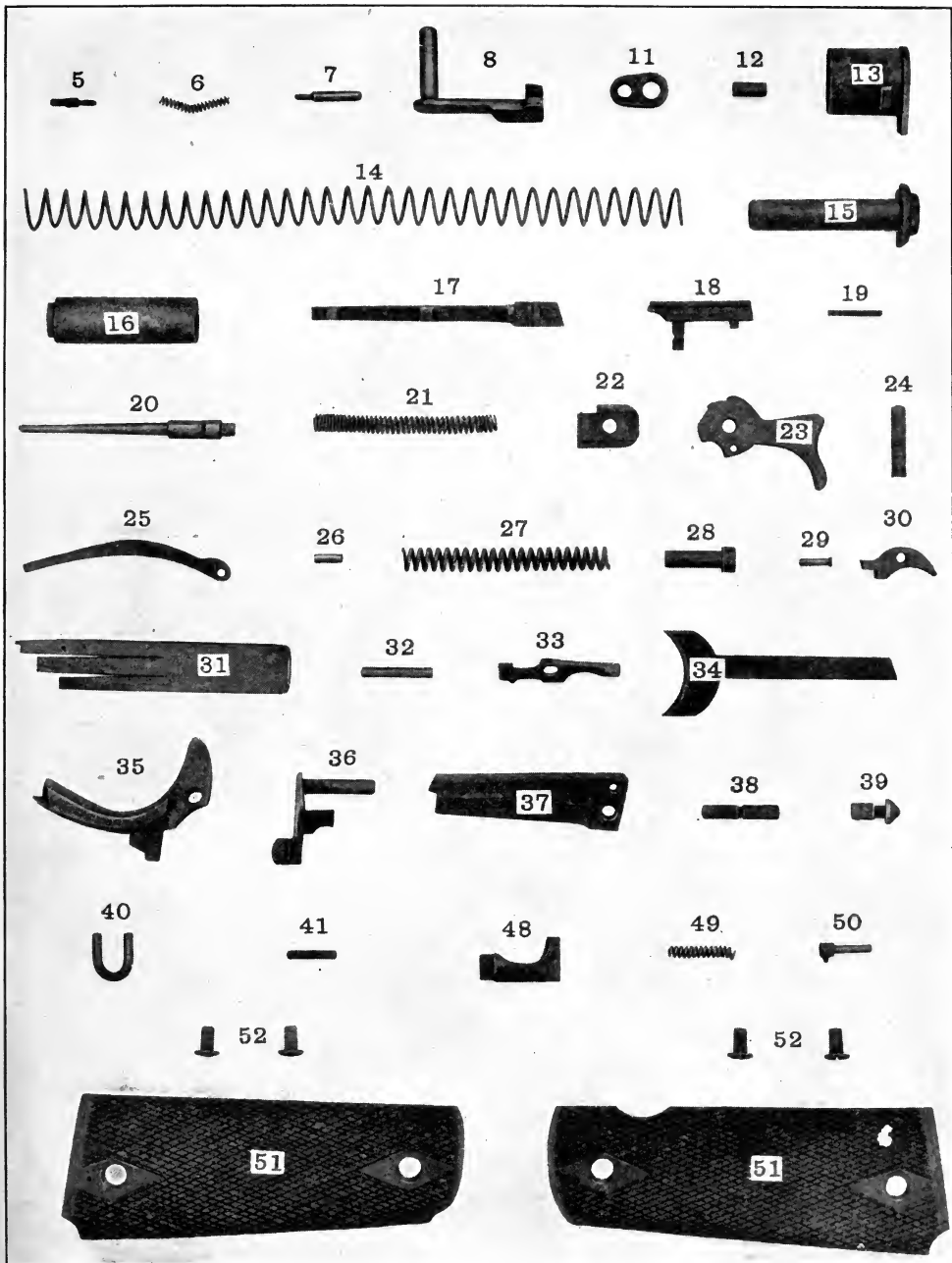

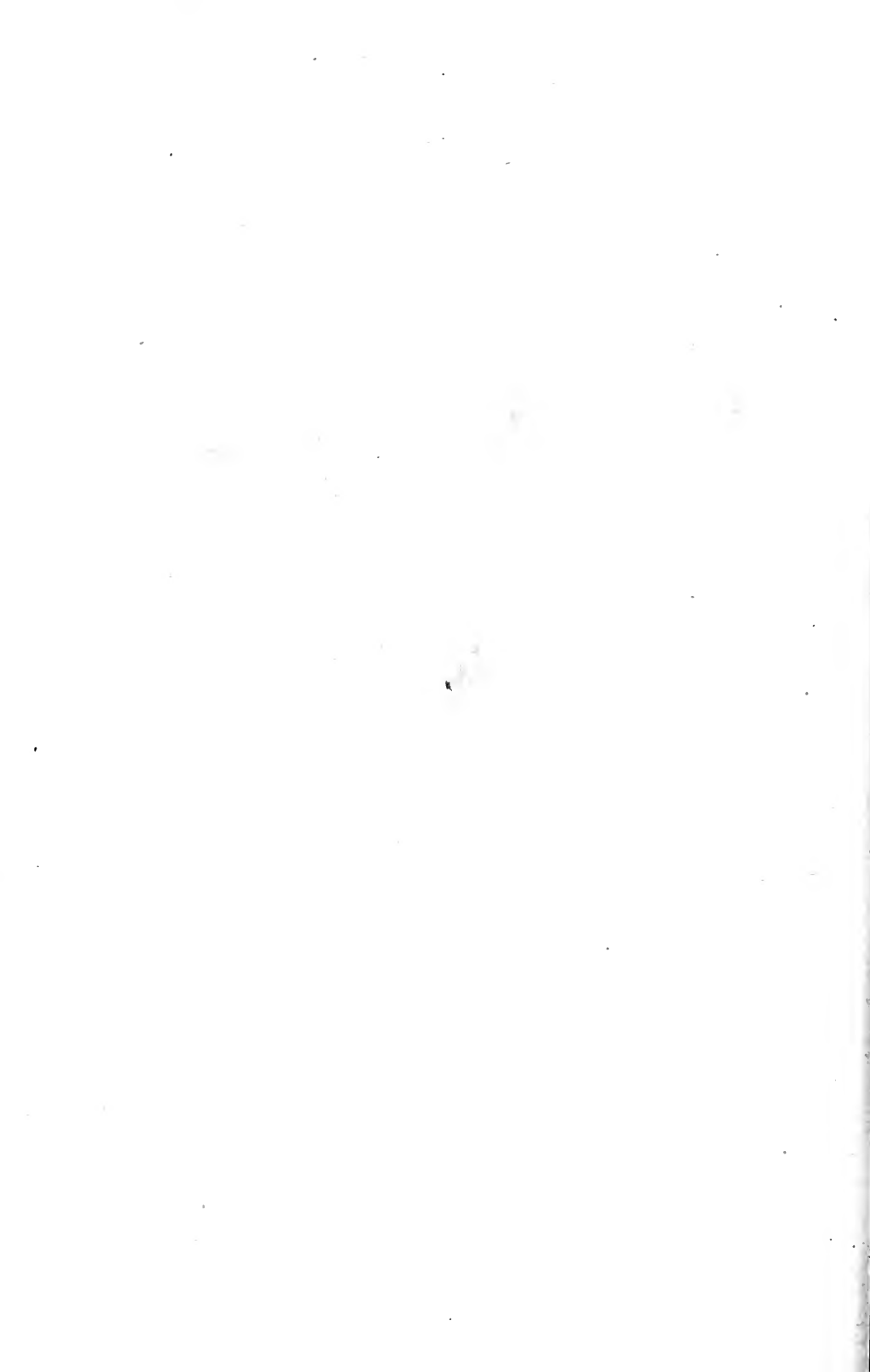

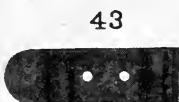

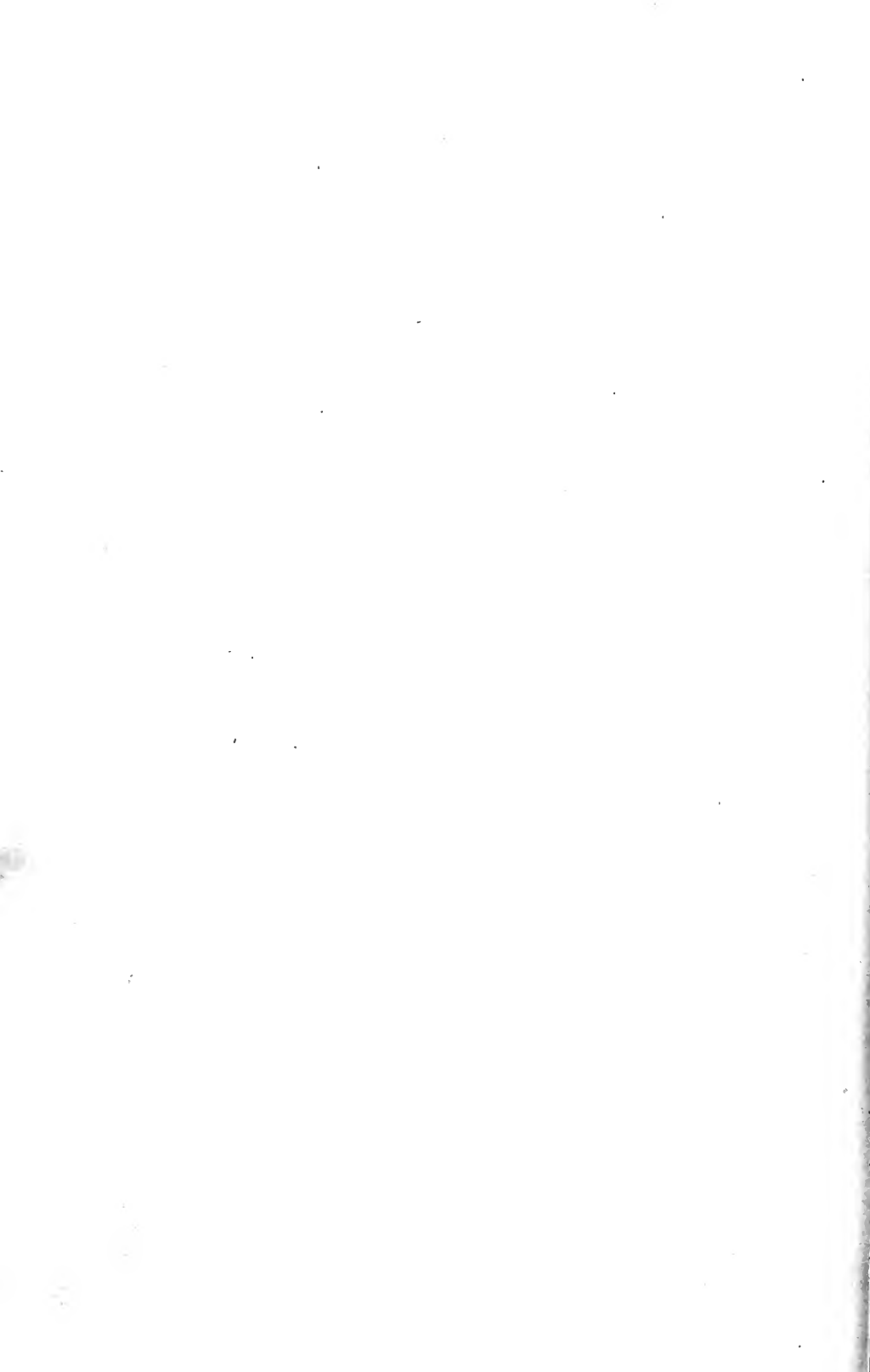



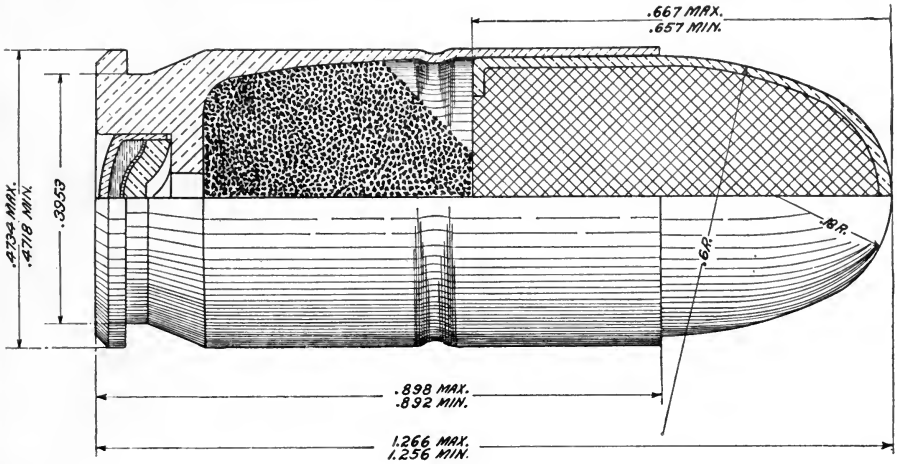

PISTOL BALL CARTRIDGE, CALIBER .45, MODEL OF 1911.

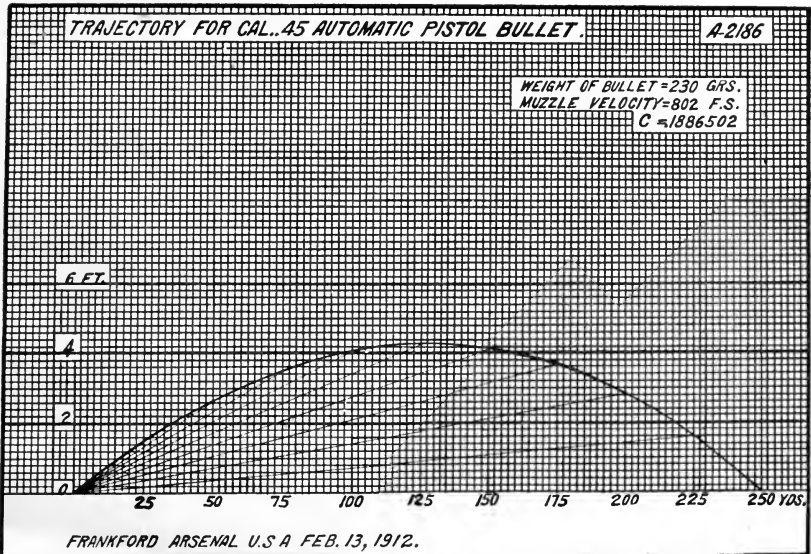





14 DAY USE  
RETURN TO DESK FROM WHICH BORROWED  
**LOAN DEPT.**

This book is due on the last date stamped below, or  
on the date to which renewed.  
Renewed books are subject to immediate recall.

~~MAR~~ 1 1968 '77

REC'D LD FEB 18 '68 -4PM

JAN 21 1970

REC'D LD JAN 7 - '70 -1PM

2

LD 21A-45m-9,'67  
(H5067s10)476B

General Library  
University of California  
Berkeley

5



