

Historic, archived document

Do not assume content reflects current scientific knowledge, policies, or practices.



84 M
.911

Miscellaneous Publication 911

**Design and
Operation
of a**

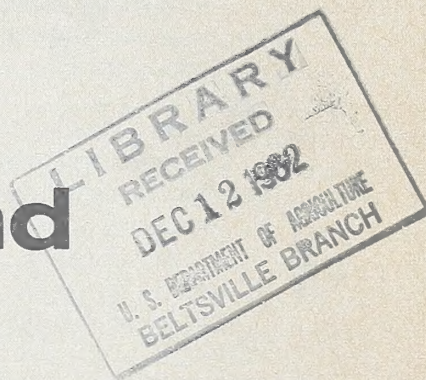

**CARBON-14
BIOSYNTHESIS
CHAMBER**

Agricultural Research Service
UNITED STATES DEPARTMENT OF AGRICULTURE

AGRICULTURE
BRANCH

Contents

	Page
Design and Construction of Chamber.....	3
Framework.....	3
Glazing.....	3
Door construction.....	5
Utility and service entrances.....	5
Facilities for plant growth.....	8
Environmental Controls.....	9
Temperature.....	9
Lighting.....	9
Carbon dioxide.....	9
Pressure regulation.....	10
Operation of the Chamber.....	11
Growth of soybeans.....	12
Growth of corn.....	13
Growth of wheat.....	13
Growth of tobacco.....	14
Summary.....	14
Literature Cited.....	15

Design and Operation of a Carbon-14 Biosynthesis Chamber

By J. H. SMITH and F. E. ALLISON, *soil scientists*, and J. F. MULLINS, *design engineer*, Soil and Water Conservation Research Division, Agricultural Research Service

Carbon-14 labeled plant material can be used to advantage in many types of research. Two of these uses—for studies of soil organic matter and for plant physiological investigations—are being employed at Beltsville, Md. Preparation of labeled plant material requires a special growth chamber in which plants can be grown for considerable periods of time in an atmosphere containing carbon dioxide labeled with carbon-14 at constant specific activity.

Several such facilities have been constructed. Some are located at the Argonne National Laboratories, Chicago, Ill. (7);¹ at the University of Bonn, Germany (6); at Rothamsted Experiment

Station, Harpenden, England (4); at the Radiological Nutriculture Laboratory, Medical College of Virginia, Richmond; and at the Danish Atomic Energy Commission, Research Establishment, Riso, Denmark (1). The above-mentioned chambers are all used for long-term labeling of plants grown in an atmosphere containing carbon-14 dioxide. A chamber for short-term labeling of plants was designed by Brown (2) and was also reported by Fisher (3).

This publication describes an improved growth chamber for growing plants in an atmosphere containing carbon-14 dioxide to produce labeled plant material.

DESIGN AND CONSTRUCTION OF CHAMBER

The biosynthesis chamber resembles a small greenhouse with flat top, 9 feet long by 6.75 feet wide by 6.75 feet high. The chamber is located in a room 23 by 13.5 feet. One corner, 6 feet by 7.5 feet, has been partitioned off to contain most of the machinery required for operation.

The air in the room in which the chamber is located is constantly changed by a positive pressure blower ducted to circulate fresh air from outside. A large exhaust fan located in the ceiling of the room provides for rapid air removal.

Framework

The framework of the chamber was assembled in four sections, as shown in figure 1, brought into the room where it was to be installed, and the sections arc-welded together. The top was made from 2 x 2 x 1/4-inch angle iron welded together to form T-shaped members in which the glass was supported. The vertical corner members were

made from 2.5 x 2.5 x 1/4-inch angle iron. The vertical window frames were made from 2 x 2 x 1/4-inch angle iron. A channel iron was welded into the horizontal framework to be used as a service entrance area for all electrical, water, and thermostat lines. The bottom section of the chamber was supported on the top, bottom, and corners by 2 x 2 x 1/4-inch angle iron. The bottom and sides, 18 inches high, were covered with 1/16-inch sheet metal, which was welded to the supporting members to form a gastight base; the sides were reinforced with 2 x 1/4-inch iron strap.

Glazing

For maximum light transmission, large windows of 1/4-inch thick plate glass were used. The size of the largest pane was calculated from the manufacturer's formula to stand a pressure variation of ± 20 inches of water.² Each pane of glass was

²Glass for Modern Needs. Engineering Data, Pittsburgh Plate Glass Co., One Gateway Center, Pittsburgh 22, Pa. June 1956.

¹Italic numbers in parentheses refer to Literature Cited, p. 15.

C-14 GROWTH CHAMBER

CHAMBER 6'-9" WIDE 9'-0" LONG 6'-9" HIGH
NOT TO SCALE

CHAMBER CONSTRUCTED
IN SECTIONS AND
WELDED TOGETHER

T'S MADE FROM 2 ANGLES WELDED TOGETHER

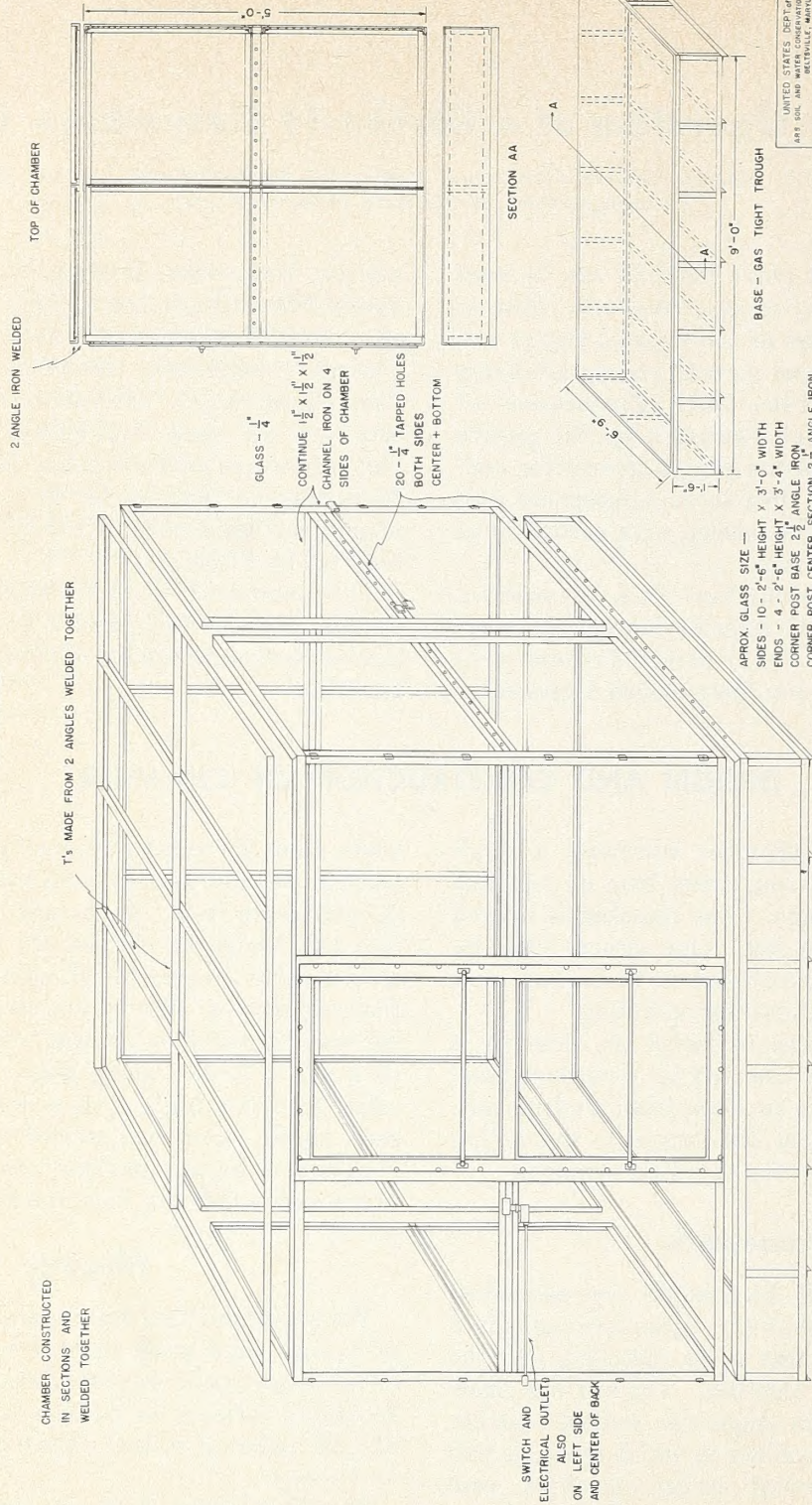

APPROX. GLASS SIZE ---
SIDES - 10' - 2" HEIGHT X 3'-0" WIDTH
ENDS - 4' - 2" HEIGHT X 3' - 4" WIDTH
CORNER POST BASE - 2 1/2" ANGLE IRON
CORNER POST CENTER SECTION 2 1/2" ANGLE IRON
ALL OTHER STRUCTURE - 2" ANGLE IRON

UNITED STATES DEPT. OF AGRICULTURE BUREAU OF PLANT INDUSTRY PLANT PHYSIOLOGY DIVISION	
C-14 GROWTH CHAMBER ASSEMBLY	
DESIGN	HOW E.S. HUNTER
DATE	11-29-40
DRAW. NO.	1 OF 3

FIGURE 1.—The C-14 growth chamber

sealed into the framework with a nonhardening calking compound that is sold under the trade name of Kalk Kord by Sears, Roebuck & Co.³

A special roller was fabricated for preparing a smooth, even layer of calking. This roller, shown in figure 2, pressed the ribbons of calking material into a uniform layer on which the glass could be easily seated. When the pane of glass was pressed against the calking, a sharp, raised area, made by a notch in the roller, showed when the glass was uniformly seated. This is a critical point! If seating is not perfect, the chamber will leak. Another ribbon of calking was then laid on top of the glass, and the angle retaining strips were fastened with bolts to hold the glass in place. When, with time, the calking pulled away from the glass, it was pressed back in place with a special tamping tool, shown in figure 2, or additional calking was added to renew the seal. The framework of the chamber was painted inside and out with white polymerizing plastic.

Figure 3 shows details of the calking and glass retainer strips for a corner installation, both top and side view. Another view of a divider between two panes of glass is also shown in figure 3 with side and top views. The joint where the side meets the top and the glazing method at that point are also detailed.

The chamber was tested for leaks by admitting a charge of Freon 12 to about 10 inches of water pressure, as indicated by a manometer, and by checking all the surface for the presence of halogen with a halogen detector.

Door Construction

For access to the chamber, a door, 29 inches wide and 59 inches high, was constructed of aluminum sheet, using two layers each 0.5-inch thick. These layers of aluminum were fastened together with blind screws and two windows machined out as indicated in figure 4. A slot was machined around each window opening, into which the glass was seated. To secure the door to the chamber, 30 studs, 0.5 inch in diameter, were set in the doorframe and the heads welded to prevent leaks. A half-round groove was machined in the door, and in this groove a gasket made from tygon tubing

³ Use of this and other trade name material mentioned in this publication does not constitute an endorsement by the U.S. Department of Agriculture.

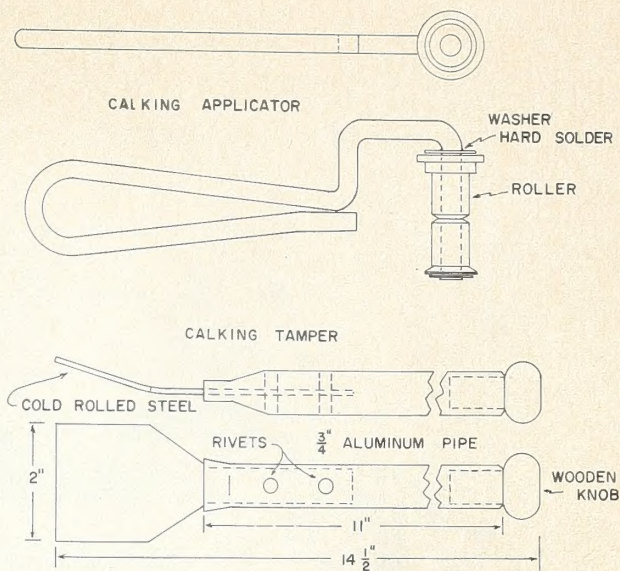

FIGURE 2.—Calking applicator and tamping tool.

was inserted. The gasket was made continuous by heat sealing it at the corners in right-angle joints. In addition to the gasket, a layer of calking was placed on the rest of the doorframe. The pressure of sealing the door extruded calking inside the doorframe, and a seal was indicated by uniform expressing of the calking compound. There has been no difficulty in sealing the door, and it is easily removed and replaced by two men.

Utility and Service Entrances

The pressure-tight electrical fitting, shown in figure 5, was one of the type used to introduce electricity into the chamber. The channel iron at the midline of the chamber was drilled and tapped to receive the 1/4-inch pipe thread on the fitting. The fitting was made of brass except the insert, which was tygon. A single No. 12 wire was inserted through the hole in the tygon sleeve, and the assembly secured in the body of the fitting and tightened to a leakproof seal.

Two sizes of pressure-tight refrigerant tubing fittings were made according to the diagram in figure 6. The connection was threaded into the channel iron in the chamber, the refrigerant tube inserted, and the fitting tightened on the tube and sealed. Two of these units were used to install 1/4-inch and 3/8-inch refrigerant tubing.

Figure 7 shows details for admitting one type of thermoregulator to the inside of the chamber.

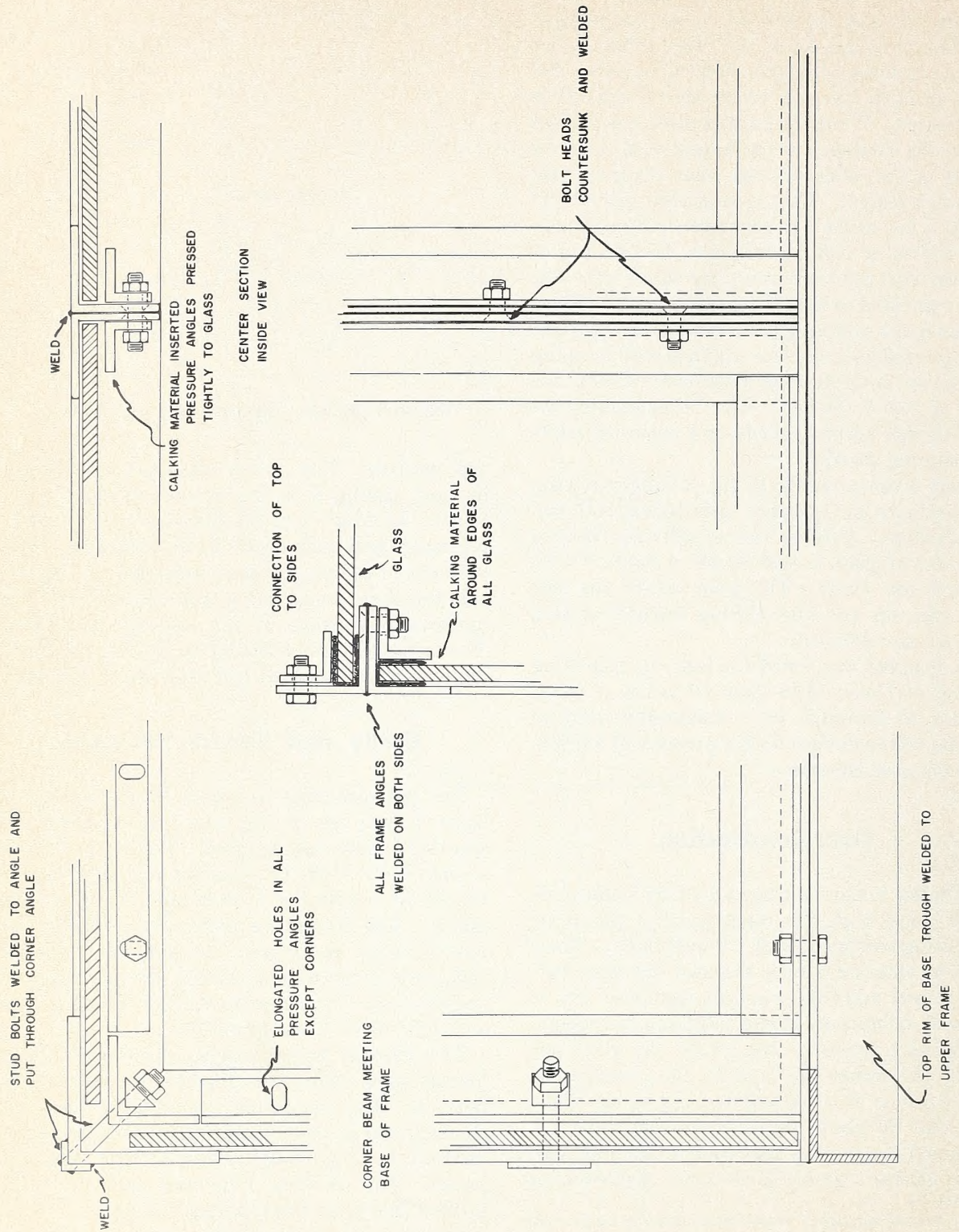
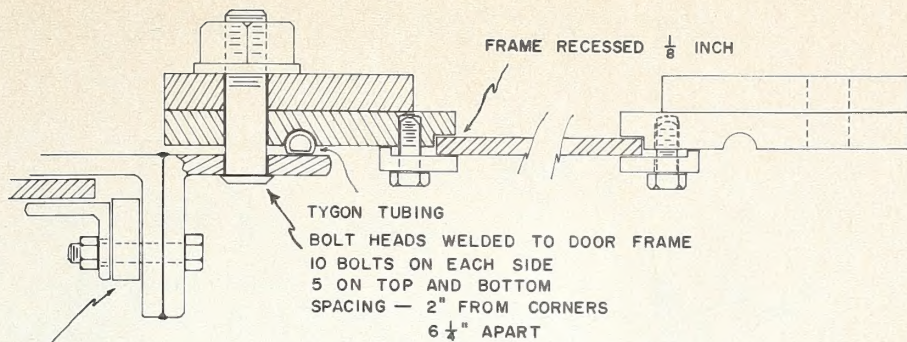

FIGURE 3.—Detailed structural and glazing cross sections.



SPACER BAR $\frac{3}{8}$ " THICK BY 1" WIDE
BETWEEN DOOR FRAME ANGLE
AND PRESSURE ANGLE
RUNS LENGTH OF PRESSURE ANGLE

INNER PLATE GROOVED FOR $\frac{3}{8}$ " O.D.
TYGON TUBING FOR SEAL

WHEN SEALING DOOR
CALKING COMPOUND IS
PLACED AROUND FRAME
BETWEEN TYGON TUBING
AND PRESSURE ANGLES
SUPPORTING GLASS

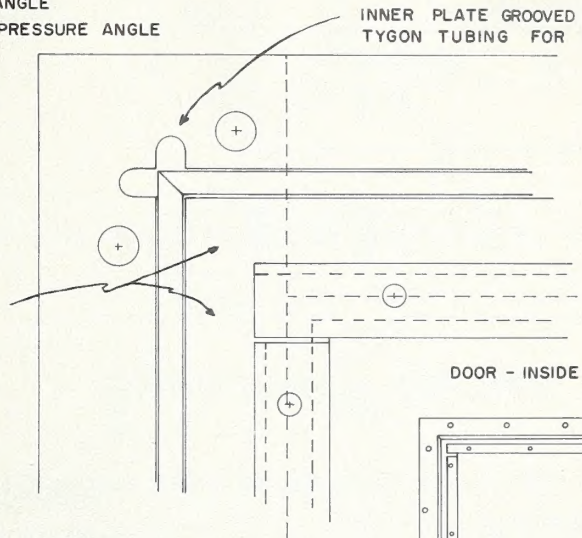

DOOR - INSIDE VIEW

DOOR FRAME MADE OF TWO
PARTS - $\frac{1}{2}$ " THICK ALUMINUM
SCREWED TOGETHER
OUTER FACE -
SIDE STRIPS 3" WIDE
CENTER STRIP 4" WIDE
INNER FACE -
SOLID PLATE RECESSED FOR GLASS
SIDES 4" WIDE
CENTER 5" WIDE

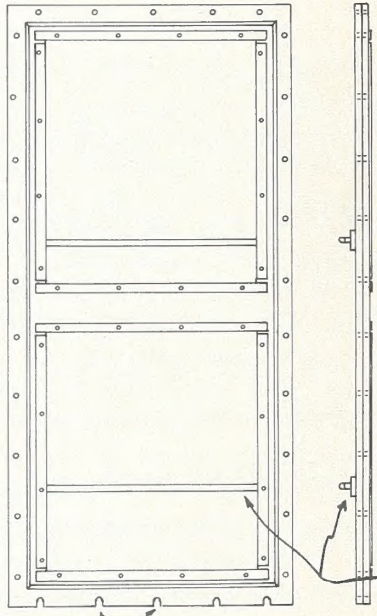

PIPE HANDLES
ON OUTSIDE

HOLES OPENED AT BASE

FIGURE 4.—Structural details of door.

PRESSURE TIGHT ELECTRICAL FITTING

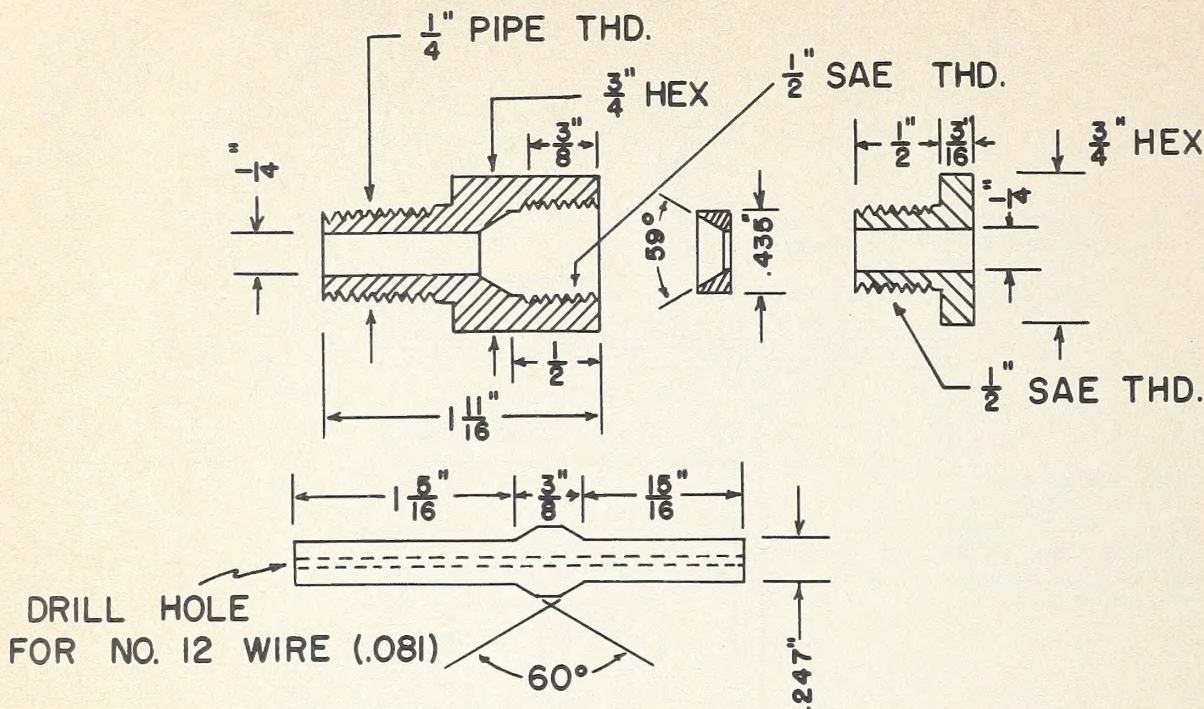

FIGURE 5.—Pressure-tight electrical fitting, showing machine work detail and dimensions.

PRESSURE TIGHT FITTINGS FOR REFRIGERATION TUBING

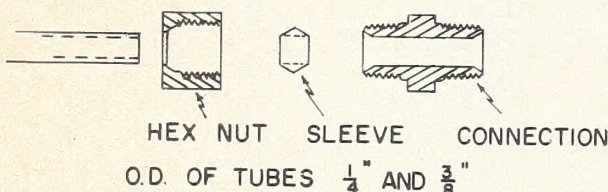

FIGURE 6.—Pressure-tight fitting for refrigeration tubing.

Facilities for Plant Growth

For simplicity of operation, plants were grown in hydroponic culture in the biosynthesis chamber. Soil was not used because of two problems: (1) maintenance of constant specific activity with soil carbon dioxide being released, and (2) recovery of roots at harvest. A uniform nutrient solution was used for growing each crop. This simplified watering of the plants, because water that was lost through transpiration or evaporation was condensed and reused. Water was condensed

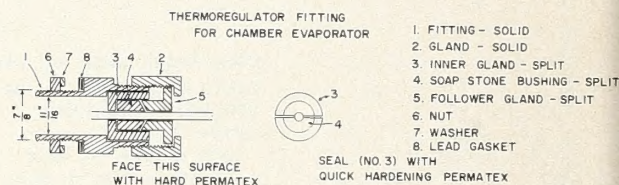

FIGURE 7.—Thermoregulator mounting fitting for passing a large bulb thermostat through the chamber wall and sealing around the small tube leading from the sensing bulb to the thermostat switch.

from the air as it contacted the cold air-conditioning coil, was passed through an ion exchanger to remove dissolved metals, and was redistributed to all the pots by siphon (fig. 8).

All liquid and air service inlet valves were modified from standard miniature brass body, stainless steel stem valves. The valves had a short nipple soldered into the inside end for connecting tubing. Forty of these valves were prepared for air and solution handling and were mounted in the channel at the midline and in the lower angle below the windows on both ends of the chamber.

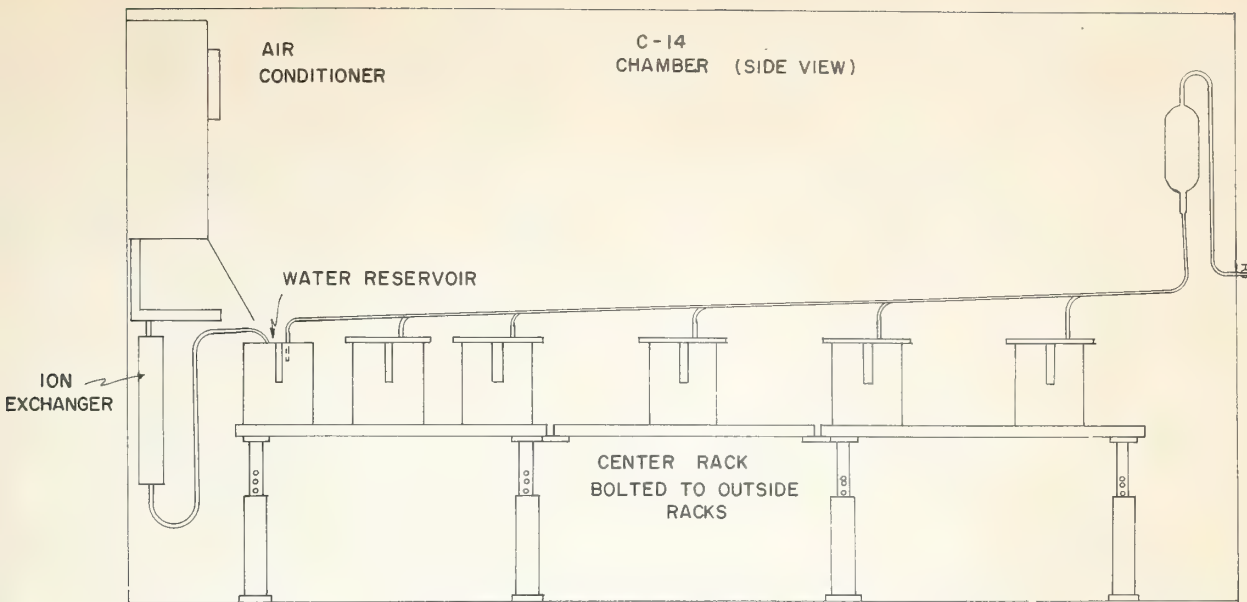

FIGURE 8.—A schematic diagram of the chamber, showing the water recirculation equipment.

ENVIRONMENTAL CONTROLS

Temperature

For temperature control of the room in which the chamber is located, a 10-horsepower, water-cooled air-conditioning compressor was installed in the equipment room with the cooling tower located outside the building. Two 5-ton capacity evaporator coils are located in opposite ends of the room, and the temperature is controlled by adjustable thermostats. Safety controls turn off the lights in case the air conditioners cease functioning, which prevents high-temperature damage to the plants.

Temperature is controlled in the biosynthesis chamber by a $\frac{3}{4}$ -horsepower compressor installed in the equipment room and an evaporator coil in the chamber. A large-bulb thermostat controls a solenoid in the liquid Freon line, and the compressor is operated on back-and-head pressure controls. Temperature in the chamber is maintained within $\pm 1.5^\circ$ F.

A 500-watt strip heater is operated continuously in the chamber to increase the heat load for the compressor to reduce humidity.

Lighting

The biosynthesis chamber is illuminated by a bank of 80 fluorescent 96-inch tubes and 24 incandescent 60-watt lamps. These produce a light intensity in excess of 1,000 foot-candles at the floor of the chamber. Readings of about 1,500 foot-candles at the horizontal midline and between 2,500 and 3,000 foot-candles at the top inside the chamber have been observed. These values are sufficiently high to give excellent growth of soybeans, wheat, corn, and tobacco.

The controls for the lighting and refrigeration are installed in the machinery room. The ballasts for the fluorescent lights are mounted on a rack and covered with a vented hood. A thermostatically controlled exhaust fan removes excess heat.

Carbon Dioxide

Radioactive carbon (C-14) is available at moderate cost only in the form of barium carbonate. It is necessary for automatic handling and reaction to have the carbonate in a soluble form. A

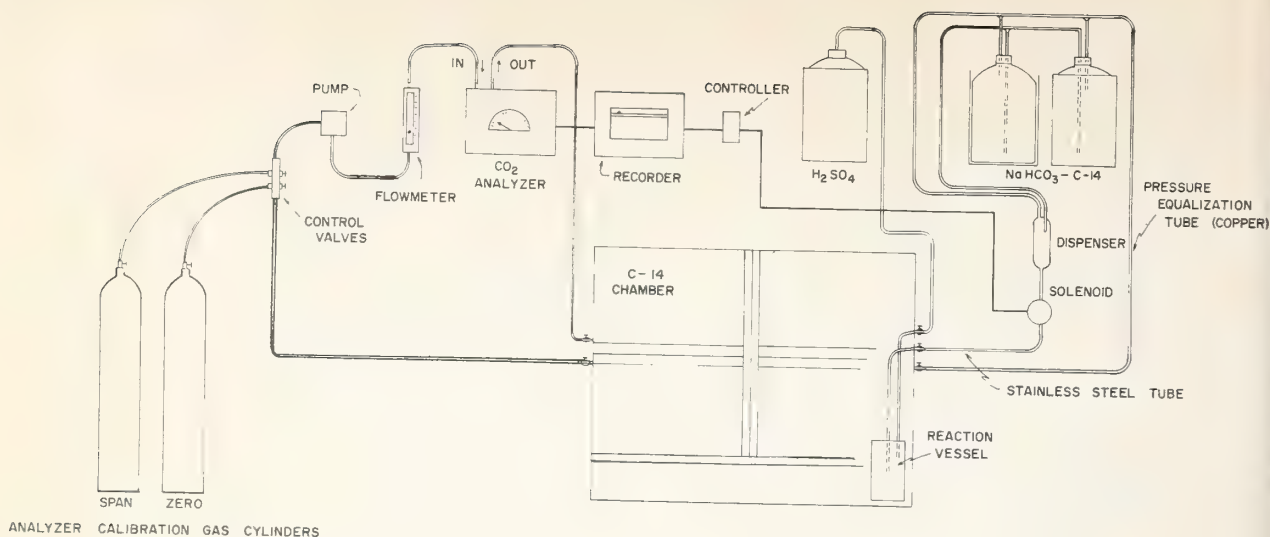

FIGURE 9.—A schematic diagram of the carbon dioxide control equipment for the biosynthesis chamber.

reaction vessel was constructed from a 200-ml. round bottom flask with a side-arm outlet and a ground glass joint inlet with stopcock. A weighed quantity of C-14 barium carbonate was placed in the flask, the inlet and outlet systems connected, and a mixture of sulfuric acid and fuming sulfuric acid admitted dropwise through the stopper in the top. A slight vacuum was applied to sweep out the evolved CO₂, which was captured in a train of bubblers containing sodium hydroxide solution. The radioactive carbonate solution thus prepared was then mixed with a large volume of sodium bicarbonate solution to produce the desired specific activity. This radioactive solution then became the "stock" from which a given crop of plants derived its carbon.

The carbon dioxide concentration in the biosynthesis chamber was continually monitored. Air from the chamber was pumped through a flow system to an infrared carbon dioxide analyzer and back into the chamber. The CO₂ content of the air was recorded on a strip chart recorder. (See fig. 9.) A special switch installed on the recorder was set to actuate the controller when a preset CO₂ concentration was reached. This opened a solenoid for a given time and emptied the contents of a metering vessel into a reaction vessel in the chamber. The reaction vessel contained sulfuric acid that reacted to evolve a quantity of carbon dioxide. During normal operation

CO₂ content was automatically maintained between 0.03 and 0.10 percent. Figure 9 gives a schematic layout of the carbon dioxide control apparatus. This system has proved to be satisfactory and has overcome the major problem involved in the operation of this facility.

The metering vessel (dispenser in fig. 9) is a special fabricated glass vessel designed to fill by siphon from the storage vessels. It has a filling tip that is restricted to require 20 to 30 minutes to fill the vessel, depending on head. The solenoid is controlled so that it opens and remains open only long enough for the vessel to empty (about 30 seconds), then closes. This delivers 300 ml. of 7-percent sodium bicarbonate solution, which upon reaction with H₂SO₄ will increase the CO₂ content of the chamber about 0.06 percent.

The cultures were aerated by recirculation of air within the chamber by a sigmoid pump. The air was pumped through a manifold and the flow rate regulated by needle valves for each vessel and through air dispersion tubes made of porous glass into the solutions (fig. 10).

Pressure Regulation

Strain imposed on the glass during installation may have weakened some of the panes; therefore, a maximum pressure well below theoretical maximum was maintained. A pressure variation of

± 4 inches of water was created by a 3° F. temperature variation. A safety valve was designed to prevent greater fluctuations (fig. 10). The device was composed of two vessels containing sodium hydroxide solution to the level that pressure inside the chamber or outside would force air through the safety valve at a rate great enough to prevent dangerous pressure buildup. Air pass-

ing through the trap was washed free of CO_2 and radioactivity. This prevented radioactive contamination from exhaust air and changes in specific activity of CO_2 in the chamber by incoming air. This trap is rarely required to function.

A manometer is located on the end of the chamber to indicate pressure differences between the inside and the outside of the chamber.

OPERATION OF THE CHAMBER

Soybeans, corn, wheat, and tobacco have been grown in the biosynthesis chamber. Although the same system of culture and environmental control was used for all crops, each crop presented different nutritional problems.

With all the crops except tobacco the seeds were germinated between moist layers of muslin in a Pyrex tray on a stainless steel screen, then transferred to nutrient solution for a few days for root and stem elongation. The soybean plants were then placed in the chamber supported in cork stoppers with their roots in nutrient solution. The corn and wheat plants were supported in funnels

filled with sand. These funnels were made from 200-ml. Erlenmeyer flasks from which the bottoms had been removed. The necks of the funnels extended into the nutrient solution in the culture vessels.

The basic nutrient used was one described by Steinberg (8) and modified by reducing the phosphorus concentration to half. The normal concentration of phosphorus was too high for growing plants in the high CO_2 concentration of the chamber, because the solubility of the solid phase calcium phosphate was increased and the phosphorus precipitated the iron. For soybeans 10

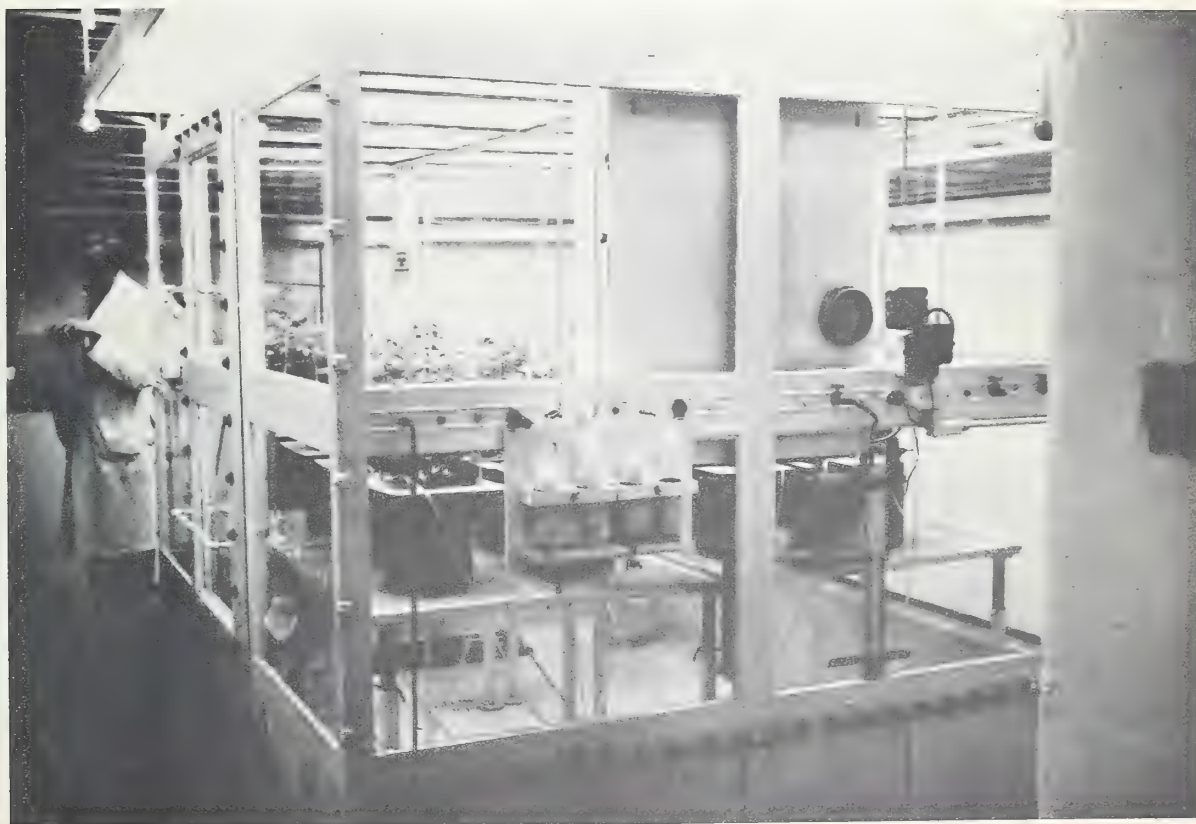

FIGURE 10.—An end view of the carbon-14 biosynthesis chamber.

BN-16478

p.p.m. of Chel 138 (ethylenediaminedihydroxyphenylacetic acid) supplied all the iron necessary for normal plant growth. With wheat the iron requirement was met with 10 p.p.m. ferric chloride. Corn required both Chel 138 at 10 p.p.m. and ferric chloride at 15 p.p.m.

The plants were placed in the chamber and observed a day or two to make certain they were all living, then the door was installed and the chamber sealed. Radioactive CO_2 was admitted, and the plants were allowed to grow to the desired stage of maturity. For harvesting the plants, the CO_2 charging equipment was turned off and the plants allowed to use the CO_2 until the concentration reached the compensation point (about 0.01 percent). The door was then opened and remaining traces of CO_2 were blown away with a fan placed in the door. The large exhaust fan cleared the traces of activity from the room. The plants

were then harvested, with the operator using adequate safety measures for handling radioactive plant material.

Growth of Soybeans

Three crops of soybeans were grown in the chamber. The first crop was a preliminary one to test the nutrient and growing conditions in the chamber and was not radioactive. The second crop was grown with carbon-14 and harvested at three stages of maturity—28, 54, and 70 days from planting. At 70 days the plants were mature and produced an excellent crop of soybeans. The third crop was grown only 28 days.

Temperature in the chamber was maintained at $75^\circ \text{F.} \pm 1.5^\circ$. Daylength was 16 hours for about 6 weeks, then was reduced to 13 hours to induce flowering. In 7 days after shortening the daylength, the plants were in full bloom.

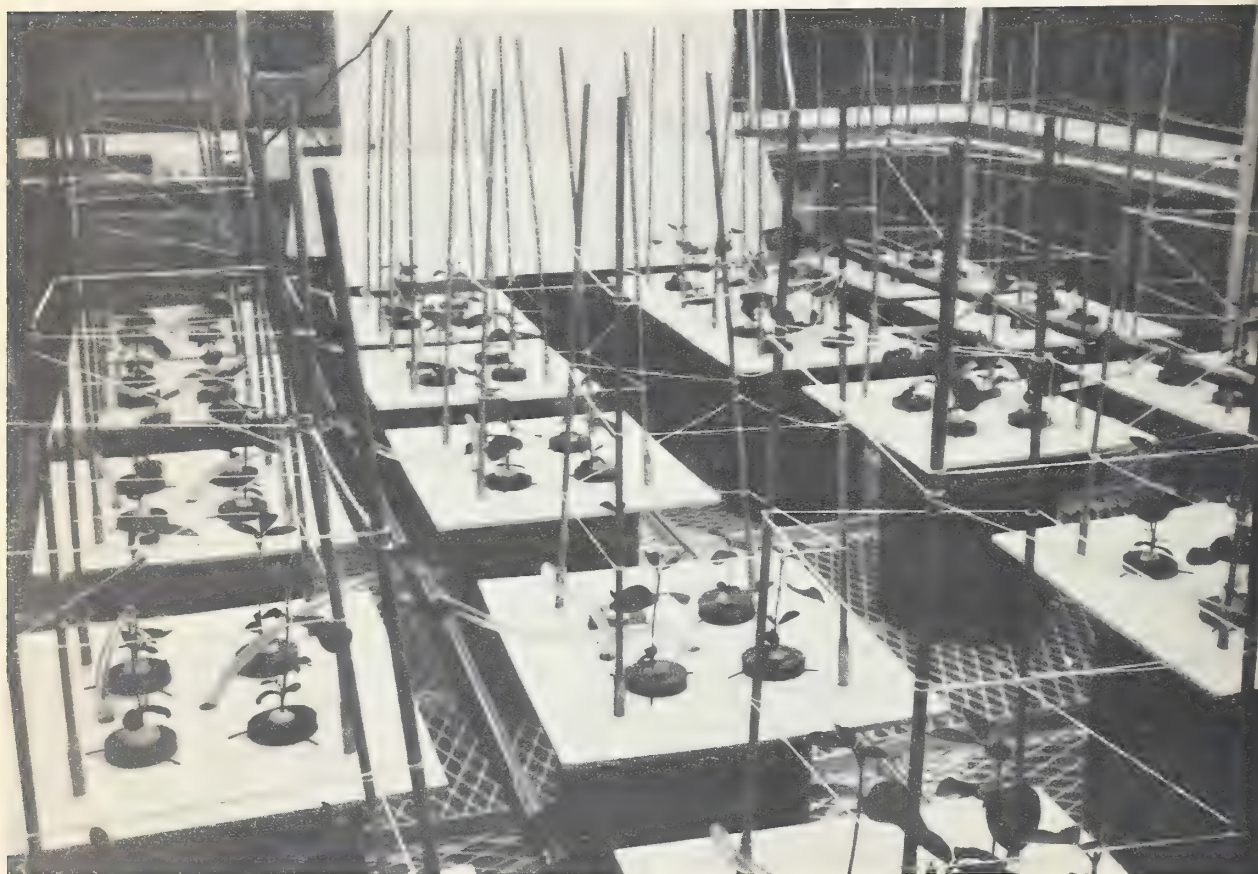
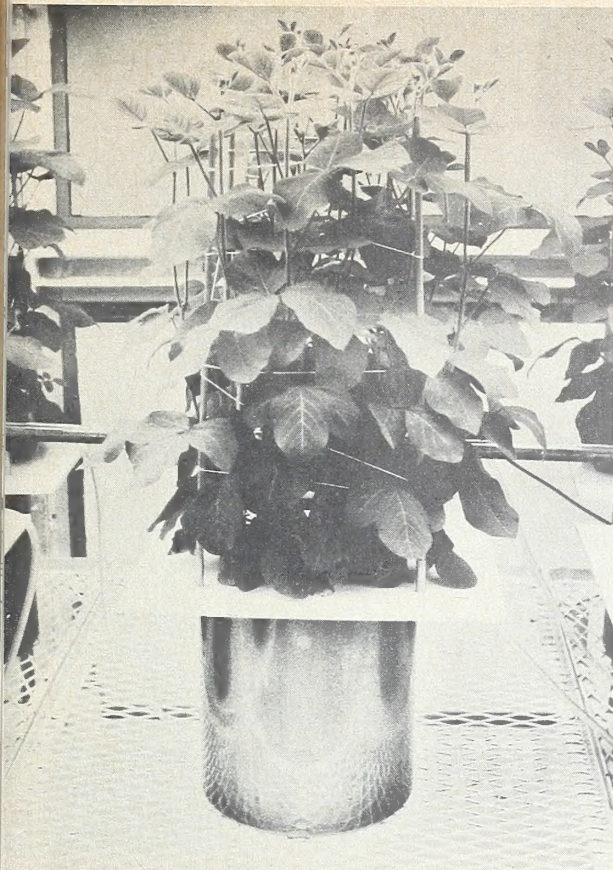

FIGURE 11.—Carbon-14 labeled soybean seedlings growing in the biosynthesis chamber.

BN-16479



BN-16483

FIGURE 12.—Carbon-14 labeled soybean plants approaching blossoming, growing in the biosynthesis chamber.

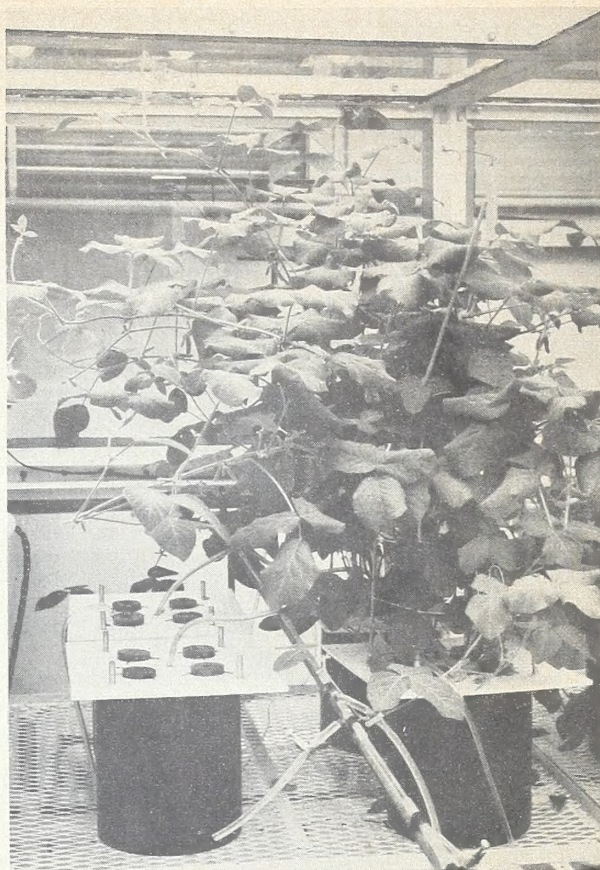

BN-16481

FIGURE 13.—Carbon-14 labeled soybean plants approaching maturity, growing in the biosynthesis chamber.

Figures 11, 12, and 13 show carbon-14 tagged soybean plants growing in the biosynthesis chamber and the excellent growth that was obtained.

Growth of Corn

Two crops of corn were grown. The first was grown about 2 months without radioactivity to determine optimum conditions, and the second crop was grown to maturity with carbon-14. The corn was harvested at two stages of maturity—at 50 days when the first tassels appeared and at 93 days when the corn was mature. Figure 14 shows corn at the silking stage growing in the chamber.

The temperature was maintained at 75° F. $\pm 1.5^{\circ}$. Daylength was 16 hours for the first 73 days, then it was reduced to 14 hours for the remainder of the time.

Special precautions had to be taken in harvesting the radioactive corn. A mass of pollen was produced and scattered throughout the inside of the chamber. Protective clothing was worn to prevent contamination by the pollen. The corn tassels were removed and discarded because of the pollen and its tendency to scatter. Corn yields by fractions of the plant were about as follows: mature corn leaves 150 grams, mature cornstalks 150 grams, mature corn on the cob 300 grams, and mature roots 50 grams. Young plants harvested at early tasseling (or 50 days) produced about 150 grams total top weight.

Growth of Wheat

The growth of the wheat crop was only partially successful because of nutrient balance problems. Both Chel 138 and ferric chloride were

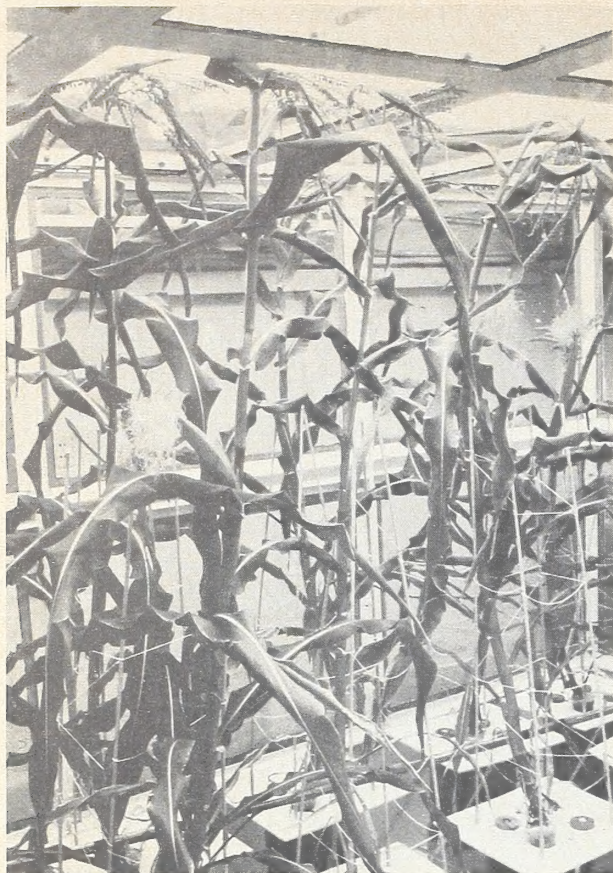

BN-16482
FIGURE 14.—Carbon-14 labeled corn plants at silking and tasseling, growing in the biosynthesis chamber.

A biosynthesis chamber was designed, and plants were grown in it from seedling stage to maturity in an atmosphere containing carbon-14 dioxide. Carbon dioxide content of the chamber was monitored and recorded constantly and CO_2 was introduced into the chamber automatically. Light intensity, daylength, temperature, aeration,

added, and symptoms that resembled copper deficiency developed. A new medium replaced the old, and the chelate was left out. The plants then recovered and grew fairly well. They were harvested at early heading when the plants were about 98 days old. Another crop of wheat will be grown without chelate.

Temperature was maintained at $67^\circ \text{F.} \pm 1.5^\circ$ for 18 days, then was increased to $70^\circ \pm 1.5^\circ$. Daylength was 14 hours. Figure 15 shows young wheat plants growing in the chamber.

Growth of Tobacco

Tobacco seed was germinated in the greenhouse, and the seedlings grown in nutrient solution until they were about 12 inches tall. Four seedlings were then placed in the growth chamber in nutrient solution C_1 described by McMurtrey (5), except that Perma Green Fe135 was added at 10 p.p.m. to supply iron. Two crops of radioactive tobacco were grown. The first was labeled with carbon-14, tritium, and nitrogen-15. The second crop was labeled with only carbon-14. Three weeks after placing the plants in the chamber, the door was opened and the suckers removed and the plants sprayed with maleic hydrazide, to reduce sucker growth and increase alkaloid production.

SUMMARY

and partial control of humidity were achieved with relatively simple equipment. Crops of corn, soybeans, wheat, and tobacco were grown in solution culture in the chamber, and the incidental problems associated with their growth were largely solved.



FIGURE 15.—Carbon-14 labeled wheat plants, growing in the biosynthesis chamber.

BN-16480

LITERATURE CITED

- (1) ANDERSEN, A., NIELSEN, G., and SORENSEN, H.
1961. GROWTH CHAMBER FOR LABELING PLANT MATERIAL UNIFORMLY WITH RADIOCARBON. *Plant Physiol.* 14 (2) : 378-383.
- (2) BROWN, J. C., TIFFIN, L. O., and HOLMES, R. S.
1958. CARBOHYDRATE AND ORGANIC ACID METABOLISM WITH C-14 DISTRIBUTION AFFECTED BY COPPER IN THATCHER WHEAT. *Plant Physiol.* 33 (1) : 38-42.
- (3) FISHER, A. C., JR.
1958. YOU AND THE OBEDIENT ATOM. *Natl. Geog. Mag.* 114 (3) : 303-353.
- (4) JENKINSON, D. S.
1960. THE PRODUCTION OF RYEGRASS LABELED WITH CARBON-14. *Plant and Soil* 13 (3) : 279-290.
- (5) McMURTREY, J. E., JR.
1933. DISTINCTIVE EFFECTS OF THE DEFICIENCY OF CERTAIN ESSENTIAL ELEMENTS ON THE GROWTH OF TOBACCO PLANTS IN SOLUTION CULTURES. U.S. Dept. of Agr. Tech. Bul. 340, 42 pp., illus.
- (6) SAUERBECK, D. VON.
1960. ZUR MARKIERUNG VON PFLANZEN MIT ¹⁴C. *Atompraxis* 6. Jahrgang, Heft 6.
- (7) SCULLY, N. J., and others.
1956. BIOSYNTHESIS IN C-14 LABELED PLANTS; AGRICULTURAL AND BIOLOGICAL RESEARCH. *Internatl. Conf. Peaceful Uses of Atomic Energy Proc.* 12: 377-385. United Nations, New York.
- (8) STEINBERG, R. A.
1951. INFLUENCE OF ACIDITY, CALCIUM AND MAGNESIUM ON GROWTH OF XANTHI TOBACCO IN WATER-CULTURE. *Plant Physiol.* 26 (1) : 37-44.



Growth Through Agricultural Progress