



This is a digital copy of a book that was preserved for generations on library shelves before it was carefully scanned by Google as part of a project to make the world's books discoverable online.

It has survived long enough for the copyright to expire and the book to enter the public domain. A public domain book is one that was never subject to copyright or whose legal copyright term has expired. Whether a book is in the public domain may vary country to country. Public domain books are our gateways to the past, representing a wealth of history, culture and knowledge that's often difficult to discover.

Marks, notations and other marginalia present in the original volume will appear in this file - a reminder of this book's long journey from the publisher to a library and finally to you.

Usage guidelines

Google is proud to partner with libraries to digitize public domain materials and make them widely accessible. Public domain books belong to the public and we are merely their custodians. Nevertheless, this work is expensive, so in order to keep providing this resource, we have taken steps to prevent abuse by commercial parties, including placing technical restrictions on automated querying.

We also ask that you:

- + *Make non-commercial use of the files* We designed Google Book Search for use by individuals, and we request that you use these files for personal, non-commercial purposes.
- + *Refrain from automated querying* Do not send automated queries of any sort to Google's system: If you are conducting research on machine translation, optical character recognition or other areas where access to a large amount of text is helpful, please contact us. We encourage the use of public domain materials for these purposes and may be able to help.
- + *Maintain attribution* The Google "watermark" you see on each file is essential for informing people about this project and helping them find additional materials through Google Book Search. Please do not remove it.
- + *Keep it legal* Whatever your use, remember that you are responsible for ensuring that what you are doing is legal. Do not assume that just because we believe a book is in the public domain for users in the United States, that the work is also in the public domain for users in other countries. Whether a book is still in copyright varies from country to country, and we can't offer guidance on whether any specific use of any specific book is allowed. Please do not assume that a book's appearance in Google Book Search means it can be used in any manner anywhere in the world. Copyright infringement liability can be quite severe.

About Google Book Search

Google's mission is to organize the world's information and to make it universally accessible and useful. Google Book Search helps readers discover the world's books while helping authors and publishers reach new audiences. You can search through the full text of this book on the web at <http://books.google.com/>

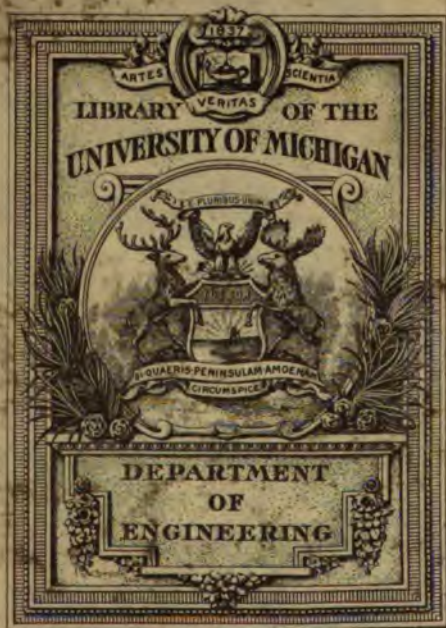

164

108

Engla. Library

TG

260

A59

THE DESIGN OF STRUCTURES.

Professor Rankine's Series of Manuals FOR ENGINEERS AND OTHERS.

In Crown 8vo, Cloth, with Diagrams.

1. APPLIED MECHANICS (A MANUAL OF). *Twelfth Edition. 12s. 6d.*
 2. CIVIL ENGINEERING (A MANUAL OF). *Seventeenth Edition. 16s.*
 3. THE STEAM ENGINE AND OTHER PRIME MOVERS. *Thirteenth Edition. 12s. 6d.*
 4. MACHINERY AND MILL-WORK. *Sixth Edition. 12s. 6d.*
 5. USEFUL RULES AND TABLES FOR ENGINEERS. With Electrical Appendix. By A. JAMIESON, C.E., F.R.S.E. *Seventh Edition. 10s. 6d.*
 6. A MECHANICAL TEXT-BOOK. By Professor RANKINE and E. F. BARKER, C.E. *Fourth Edition. 9s.*
- PROFESSOR RANKINE'S MISCELLANEOUS SCIENTIFIC PAPERS. With Memoir by Professor TAIT, M.A., and Fine Portrait on Steel. Royal 8vo, handsome cloth. *31s. 6d.*

Medium 8vo, with 48 Lithographic Plates and Numerous Woodcuts. 25s.

HYDRAULIC POWER AND HYDRAULIC MACHINERY.

For the Use of Practical Engineers and Students.

By HENRY ROBINSON, M. INST. C.E., F.G.S.,

Professor of Surveying and Civil Engineering, King's College, London.

"A Book of great Professional usefulness."—*Iron.*

Medium 8vo, with Numerous Lithographic Plates and Woodcuts, 30s.

BRIDGE-CONSTRUCTION (A Practical Treatise on).

A Text-book on the Design and Construction of Bridges in Iron and Steel.

By T. CLAXTON FIDLER, M. INST. C.E.

"Should prove not only an INDISPENSABLE Hand-book for the Practical Engineer, but also a stimulating Treatise to the Student of Mathematical Mechanics and Elasticity."—*Nature.*

SECOND EDITION. *Pocket-Size, Leather; also, for Office use, in Crown 8vo, Cloth. 12s.*

BOILERS: THEIR CONSTRUCTION AND STRENGTH.

A Handbook of Rules, Formuls, Tables, &c., relative to Material, Scantlings and Pressures, Safety Valves, &c. For the use of Engineers, Inspectors, Surveyors, Draughtsmen, Boilermakers, and Steam Users.

By T. W. TRAILL, F.E.R.N., M. INST. C.E.,

Engineer-Surveyor-in-Chief to the Board of Trade.

"We can strongly recommend Mr. Traill's Book as being the most complete and eminently practical work on the subject."—*Marine Engineer.*

With Illustrations. 9s.

FUEL AND WATER.

A Manual for Users of Steam and Water.

By PROF. FR. SCHWACKHÖFER

AND

WALTER R. BROWNE, M.A., C.E.

"The PRACTICAL UTILITY of the work is beyond question."—*Mining Journal.*

LONDON: CHARLES GRIFFIN & CO., EXETER STREET, STRAND.

THE

395-26

DESIGN OF STRUCTURES:

A Practical Treatise

ON

THE BUILDING OF BRIDGES, ROOFS, &c.

BY

Samuel,

S. ANGLIN, C. E.,

MASTER OF ENGINEERING, ROYAL UNIVERSITY OF IRELAND,
LATE WHITWORTH SCHOLAR, ETC.

With Numerous Diagrams, Examples, and Tables.

LONDON:

CHARLES GRIFFIN & COMPANY,

EXETER STREET, STRAND.

1891.

[All Rights Reserved.]



PREFACE.

IN undertaking this work, my principal object has been to supply the want, long and universally felt among Students of Engineering and Architecture, of a concise Text-book on Structures, requiring on the part of the reader a knowledge of elementary mathematics only. In order to obtain complete information on the subject it has been necessary, hitherto, to consult a large number of books, and these, moreover, have been generally too advanced for the average student. The present work is an attempt to remove, or at least to minimise, these disadvantages.

Throughout, my aim has been to treat the different branches of the subject from a *practical*, as well as from a theoretical, stand-point; and with this object I have introduced, and carefully worked out, a large number of Practical Examples such as occur in the every-day experience of the Engineer. Several of these Examples are solved both analytically and graphically, one method being used as a check upon the other.

The subject of Graphic Statics has only of recent years been generally applied in this country to determine the Stresses on Framed Structures; and in too many cases this is done without a knowledge of the principles upon which the science is founded. I have tried to explain it from first

1190 m. r.

Revised 6-2-42 M J V

principles, and the student will find in this system a valuable aid in determining the stresses on all irregularly-framed structures.

Although the work has been designed mainly for the class of readers above referred to, it is further hoped that it may prove a useful book of Reference to those engaged in the profession generally. Several chapters are devoted to the practical side of the subject—those relating to the Strength of Joints, and to Punching, Drilling, Rivetting, and other processes connected with the manufacture of Bridges, Roofs, and Structural work generally, being the result of many years' experience in the bridge-yard; and it is hoped that the information given on this branch of the subject may be of value to the practical bridge-builder.

S. A.

PRESTWICH, *January*, 1891.

CONTENTS.

CHAPTER I.—STRESSES AND STRAINS.

Art.	Page	Art.	Page
1. Framed Structures—Definition,	1	5. Measurement of Stresses and Strains,	3
2. Constituent parts of Structures—Beams, Struts, and Ties,	1	6. Tensile Stresses,	3
3. External Loads on Structures—Dead and Live Loads,	1	7. Compressive Stresses,	3
4. Stresses and Strains—Compressive—Tensile—Shearing Stresses,	2	8. Shearing Stresses,	4
		9. Transverse Stresses,	4
		10. Torsional or Twisting Stresses,	5
		11. Long Struts—Do not fail by direct crushing,	7
		Table of Weights of Materials,	8

CHAPTER II.—ELASTICITY AND FATIGUE OF MATERIALS.

12. Elasticity of Materials—Definition,	11	19. Ultimate Strength—Working Load—Factor of Safety—Contraction of Area and Elongation of Bar under Tensile Stress—Different kinds of Loads on Structures,	16
13. Limits of Elasticity in Materials,	11	20. Value of the Factor of Safety depends on the kind of Load and the nature of the Material—Elastic Limit a good measure of Strength,	17
14. Elasticity an important Measure of Strength,	12	21. Proof Strength—Proof Load a multiple of the Working Load—Table of Proportions of Proof, Working and Ultimate Strengths for different Materials,	18
15. Modulus of Elasticity—Hooke's Law of Elastic Reaction,	12	22. Resilience—Definition—Method of Determining,	19
16. Different Methods of determining the Modulus of Elasticity—by Compression, by Tension, by Transverse Stress,	12	23. Fatigue of Materials,	21
17. Deflection of Beams—Method of determining Deflection—Table of Modulus of Elasticity for different Materials,	13	24. Experiments relating to the Fatigue of Cast- and Wrought-Iron Bars and Girders,	22
18. Set—Definition—Temporary and Permanent Set—Members of Structures should not be strained beyond the Elastic Limit of the Material—Not advisable to have different Materials in the same Structure,	16	25. Wöhler's and Fairbairn's Experiments on the Fatigue of Materials,	23

CHAPTER III.—PROPERTIES OF MATERIALS AS USED IN STRUCTURES.

Art.	Page	Art.	Page
26. Principal Materials used in Structural Work—Timber, Cast Iron, Wrought Iron, Mild Steel, . . .	25	36. Tensile Strength of Wrought Iron—Table of Strengths and Contraction of Area both <i>with</i> and <i>across</i> the Grain—Superior Strengths of Small Sections, . . .	32
27. Variation in the Strength of Timber—Effect of Alternate Wetness and Dryness—Dry Rot—Best time for Felling Timber, . . .	25	37. Tensile Strength of Wrought Iron across the Fibre, . . .	33
28. Seasoning and Preserving Timber—Desiccating Process—Paint a Preservation against Moisture, . . .	26	38. Strength of Welds—Means for counteracting Diminished Strength, . . .	34
29. Tensile and Crushing Strengths of Timber, . . .	26	39. Iron Wire—Tensile Strength diminished by Annealing, . . .	34
30. Uses of Cast Iron in Structures somewhat Limited—Imperfections in Cast Iron—Well adapted for Direct Compressive Stresses and for Ornamental Work, . . .	27	40. Compressive Strength of Wrought Iron, . . .	34
31. Varieties of Cast Iron, white in colour is hard and brittle; gray is soft and tough—Tenacity, . . .	28	41. Effects of Annealing on Wrought Iron, . . .	34
32. Relative Strengths of Small and Large Castings—Skin of Casting adds to the Transverse and Crushing Strengths, . . .	28	42. Shearing Strength of Wrought Iron—Table of Shearing Strengths, . . .	35
33. Engineers' requirements in Castings—Table of Tensile and Transverse Strengths—Superior Strength of Castings made in America, . . .	29	43. Expansion and Contraction due to Changes of Temperature—Table of Coefficients of Linear Expansion, . . .	35
34. Wrought Iron as used in Structures—Varieties of Wrought Iron, . . .	31	44. Different Kinds of Steel—Advantages of Mild Steel for Structural Work, . . .	37
35. Testing Wrought Iron—Contraction of Area at Point of Rupture—Extension, . . .	32	45. Strength of Steel, . . .	37
		46. Elasticity of Steel—Modulus of Compressive and Tensile Elasticity, . . .	38
		47. Admiralty Tests for Steel, . . .	38
		48. Lloyd's Tests for Steel, . . .	39
		49. Rules of the French Admiralty, . . .	39
		50. Steel Castings—Advisability of Annealing Steel Castings, . . .	39
		51. Effects of Annealing on Steel—Table of Strengths of Annealed and Non-annealed Steel, . . .	40
		52. Treatment of Steel by Hydraulic Pressure—Sir Jos. Whitworth's Method, . . .	40

CHAPTER IV.—MECHANICAL LAWS RELATING TO STRESSES ON STRUCTURES.

Art	Page	Art	Page
53. Diagrams of Forces—Principle of Moments—The Parallelogram or Polygon of Forces, . . .	41	57. Graphic Method of Determining the Stresses on Framed Structures, . .	45
54. Mechanical Forces—Methods of Determining a Force, . . .	42	58. Equilibrium of Three Forces acting on a Point—Parallelogram of Forces, . .	45
55. Forces of Compression and Extension, . . .	43	59. Resolution of Forces, . .	47
56. Principle of Moments, . .	43	60. Triangle of Forces, . . .	47
		61. Polygon of Forces, . . .	50

CHAPTER V.—EXTERNAL LOADS ON BEAMS—SUPPORTING FORCES.

62. Different kinds of Beams—Simple Beams—Semi-Beams or Cantilevers—Continuous Beams, . .	51	67. Beam projecting over One Support, . . .	58
63. External Forces on Beams—Supporting Forces—Conditions of Equilibrium—Concentrated Loads—Uniformly Distributed Loads, . . .	52	68. Beam projecting over both Supports, . . .	60
64. Beam resting on Two Supports and Loaded with a Single Weight, . . .	53	69. Continuous Beams, . . .	61
65. Beam resting on Two Supports and Loaded with two or more Weights, . .	55	70. Continuous Beam of <i>Uniform Section</i> and Two Equal Spans Uniformly Loaded, . . .	63
66. Beam resting on Two Supports and Loaded with a Distributed Weight, . .	55	71. Continuous Beam of <i>Uniform Section</i> and more than Two Equal Spans Uniformly Loaded—Table of Supporting Forces—Continuous Beams of <i>Uniform Strength</i> , . .	65

CHAPTER VI.—BENDING MOMENTS FOR FIXED LOADS.

72. Definition of Bending Moment, . . .	66	78. Position of Maximum Bending Moment, . . .	73
73. Bending Moment in a Beam produced by a Single Load, . . .	67	79. Purely Graphic Solution, . .	74
74. Beam loaded with a number of Weights, . . .	68	80. Graphic Determination of the Centre of Gravity of the Loads on a Beam, . .	76
75. Diagram of Bending Moments, . . .	69	81. CASE III.—Beam supported at both ends and Loaded with a Uniform Weight, . .	77
76. CASE I.—Beam supported at each end and loaded with a Single Weight, . .	70	82. Beam loaded Uniformly over a portion of its length next to One Support, . . .	79
77. CASE II.—Beam supported at both ends and loaded with two or more Weights, . . .	71	83. Beam Loaded Uniformly over an Intermediate portion of its Length, . .	81

Art.	Page	Art.	Page
84. Beam Loaded Uniformly on Two Segments with Weights of Different Intensity,	84	93. Beam Supported at One End and an Intermediate Point, and Loaded at the Other End,	95
85. Bending Moments on Semi-Beams,	84	94. Beam Supported at Two Intermediate Points,	99
86. Cantilever Loaded with a Single Weight at its Free End,	84	95. Beam, as before, with an Additional Load,	100
87. Cantilever Loaded with more than One Weight,	85	96. Bending Moments in Continuous Beams,	103
88. Cantilever Loaded Uniformly over its Entire Length,	88	97. Determination of the Points of Inflexion in Continuous Beams of Two Equal Spans and of Uniform Section,	104
89. Cantilever with a Uniform, and also a Concentrated, Load,	89	98. Bending Moments in a Continuous Beam of Two Equal Spans and of Uniform Section,	105
90. Cantilever Loaded Uniformly over a portion of its Length,	89	99. Bending Moments in Continuous Beams of Uniform Strength,	107
91. Beam of Uniform Section Securely Fixed at its Ends and Loaded at the Centre,	91	100. Girders of Uniform Strength most Common in Large Spans,	107
92. Beam of Uniform Section Fixed at the Ends and Loaded Uniformly,	93		

CHAPTER VII.—BENDING MOMENTS FOR MOVING LOADS.

101. Definition of a Moving or Travelling Load,	110	105. Diagram of the latter,	117
102. Beam exposed to a Uniform Moving Load less in Length than in Span,	111	106. Beam Loaded with Two Concentrated and Unequal Weights at a fixed interval apart,	118
103. Beam Exposed to a Single Concentrated Rolling Load,	114	107. Graphic Method of finding the Position of the Rolling Load so as to produce the Maximum Bending Moment at any Section,	120
104. Beam exposed to a Rolling Load consisting of Two Concentrated and Equal Weights,	114		

CHAPTER VIII.—SHEARING FORCES ON BEAMS.

108. Definition of the Shearing Force on the Section of a Loaded Beam,	121	110. Purely Graphical Representation of Shearing Forces,	124
109. Maximum Shearing Force for Fixed Loads—Graphic Representation of Shearing Forces,	122	111. Beam Loaded Uniformly over its Entire Length,	124
		112. Beam Loaded Uniformly over a Portion of its Length,	125

Art.	Page	Art.	Page
113. Beam Loaded Uniformly over Two Segments with Different Intensities of Load,	127	118. Beam Exposed to Two Concentrated Rolling Loads,	131
114. Cantilever Loaded with Concentrated Weights,	127	119. Beam Exposed to a Uniformly Distributed Rolling Load,	132
115. Cantilever Uniformly Loaded,	128	120. Diagram of Shearing Forces when the Length of the Load is equal to, or greater than, the Span,	133
116. Cantilever with Uniform and Concentrated Loads,	128	121. Diagram of Shearing Forces when the Length of the Load is less than the Span,	133
117. Beam Exposed to a Concentrated Rolling Load,	130		

CHAPTER IX.—CENTRE OF GRAVITY AND MOMENT OF INERTIA OF PLANE SURFACES.

122. Centre of Gravity of simple Geometrical Surfaces,	136	128. Moment of Inertia of Complex Figures,	141
123. Centre of Gravity of the Section of a Flanged Girder,	137	129. Moment of Inertia of a Circular Disc,	142
124. Centre of Gravity of T-Section,	139	130. Moments of Inertia of a Circular Ring and Hollow Rectangle,	143
125. Practical Method of finding the Centre of Gravity,	139	131. Moment of Inertia of H-Section with Equal Flanges,	145
126. Definition of the Moment of Inertia of a Plane Surface,	140	132. Moments of Inertia of Beams of Various Sections,	149
127. Moment of Inertia of a Rectangle,	140		

CHAPTER X.—INTERNAL STRESSES IN BEAMS.

133. Theory of Stresses on Loaded Beams,	151	141. Beams of H-Section with Unequal Flanges,	160
134. Method of Determining the Moment of Resistance for Different Beams,	154	142. Beams of T-Section,	162
135. Beams of Solid Rectangular Section,	155	143. Discrepancies between Theory and Practice in Determining the Strength of Solid Beams—Table of Moduli of Rupture for Different Sections and Materials,	162
136. Beams of Solid Square Section, one Diagonal being Vertical,	156	144. Strength of Solid Rectangular Cantilevers Uniformly Loaded,	169
137. Beams of Solid Circular Section,	156	145. Strength of Solid Rectangular Cantilevers Loaded at the Free End,	170
138. Beams of Hollow Circular Section,	156	146. Solid Rectangular Beams Supported at both Ends and Loaded at the Centre,	171
139. Beams of Hollow Rectangular Section,	157		
140. Beams of H-Section with Equal Flanges,	157		

Art.	Page	Art.	Page
147. Solid Rectangular Beams Supported at both Ends and Loaded Uniformly—Rolled Girders,	171	148. Approximate Method of Calculating the Strength of Rolled Girders—Table of Strengths,	184

CHAPTER XI.—COLUMNS AND LONG STRUTS.

149. Strength of Columns Theoretically and Practically Considered,	187	158. Columns of + and H-Section,	198
150. Short Columns—Method of Failure,	188	159. Gordon's Rules for Columns—Table of Breaking Weights,	198
151. Long Columns—Method of Failure,	188	160. Rankine's Rules for the Strength of Columns—Table of Squares of Radii of Gyration,	203
152. Columns of Medium Length—Method of Failure—Strength of Flat- and Round-ended Columns,	188	161. Wrought-Iron Columns of Solid Section,	205
153. Position of Fracture in Long Cast-Iron Columns,	189	162. Rankine's Rules for Wrought-Iron Columns,	206
154. Rules for Determining the Strength of Long Cast-Iron Columns, either Solid or Hollow, and Circular in Section—Hodgkinson's Rules—Table of 3 ⁵ th and 1 ⁶ 3rd powers,	190	163. Strength of Solid Round Wrought-Iron Columns,	206
155. Strength of Columns of Medium Length,	195	164. Wrought-Iron Tubular Columns—Table of Strengths,	207
156. Safe Working Load on Cast-Iron Columns,	196	165. Wrought-Iron Struts of Angle-, Tee-, and Channel-Sections,	209
157. Proportions of Hollow Cast-Iron Columns,	196	166. Mr. Christie's Experiments on Wrought-Iron Struts,	211
		167. Steel Columns of Solid, Round, and Rectangular Sections—Mr. Baker's Rules,	212
		168. Steel Columns of L- and H-Section,	212

CHAPTER XII.—BRACED GIRDERS—BOLLMAN TRUSS—TRAPEZOIDAL TRUSS—FINK TRUSS.

169. Braced Girders—Definition,	214	174. Bollman Truss of any Number of Panels,	218
170. Different kinds of Braced Girders,	214	175. Defects of the Bollman Truss,	222
171. Simple Triangular Truss with Single Load—Bollman Truss,	214	176. Trapezoidal Truss,	222
172. Bollman Truss with Distributed Load,	217	177. Trapezoidal Truss of any Number of Panels,	223
173. Bollman Truss of Three Divisions,	218	178. Fink Truss,	225
		179. Fink Truss of any Number of Equal Panels,	227

CHAPTER XIII.—BRACED GIRDERS (*continued*)—WARREN GIRDERS.

Art.	Page	Art.	Page
180. Definition of Warren Girder,	233	184. Warren Girders Uniformly Loaded,	242
181. Nature of Stresses in Warren Girders,	233	185. Semi-girders Loaded at their Extremities,	249
182. Girder Supported at both Ends and Loaded at an Intermediate Point,	233	186. Cantilever Uniformly Loaded,	252
183. Bow's Method of Lettering Diagrams,	237	187. Warren Girders with Vertical Bracings,	255

CHAPTER XIV.—BRACED GIRDERS (*continued*)—LATTICE GIRDERS—LINVILLE TRUSSES.

188. Definition of Lattice Girder,	258	192. Linville Truss Loaded with Single Weight at any Point,	263
189. Stresses on Lattice Girders,	258	193. Linville Truss Weighted with an Evenly Distributed Load—Case I.,	266
190. Linville Trusses,	262	194. Linville Truss Weighted with an Evenly Distributed Load—Case II.,	269
191. Linville Truss Loaded with Single Weight at the Centre,	263		

CHAPTER XV.—BRACED GIRDERS (*continued*)—BRACED GIRDERS WITH CURVED FLANGES.

195. Different Forms of Curved Girders,	277	198. Professor Ritter's Method of Moments,	279
196. Calculation of Stresses in Braced Girders with Curved Flanges,	277	199. Bowstring Girder Uniformly Loaded,	281
197. Bowstring Girders,	277	200. Fish-bellied Girders,	286

CHAPTER XVI.—CRANES—FRAMEWORK.

201. Definition of a Crane,	291	Chain is taken into Account,	294
202. Jib Cranes,	291	206. Derrick Crane,	299
203. External Forces on Cranes,	292	207. Sheer Legs,	300
204. Stresses on Jib Crane when the Effect of the Chain is not considered,	293	208. Tripods,	301
205. Stresses on Jib Crane when the Effect of the		209. Cranes with Rolling Loads,	301
		210. Wharf Crane,	304

CHAPTER XVII.—ARCHES.

211. Circumstances which Modify Stresses on Arches,	307	213. Linear Arches—Line of Pressures,	306
212. Different Forms of Metal Arches,	307	214. Different Kinds of Stresses on Arches,	310

Art.	Page	Art.	Page
215. Method of Loading Arched Ribs,	312	218. Braced Arch Loaded with a Number of Weights, . .	314
216. Braced Iron Arches, . .	312	219. Stresses on the Braced Arch by the Principle of Moments,	318
217. Braced Arch with Single Load,	313		

CHAPTER XVIII.—ROOFS—STRESSES ON ROOF TRUSSES.

220. Divisions of Roofing, . .	319	223. French Truss,	335
221. Main Principals,	319	224. Saw-tooth Truss,	337
222. Simple Forms of Roof Trusses,	320	225. Curved Roof Trusses, . .	339

CHAPTER XIX.—ROOFS (continued)—PRACTICAL DETAILS.

226. Design of Roofs, Dependent on Circumstances,	345	239. Different Kinds of Roof Coverings — Table of Weights,	354
227. Loads on Roofs—Statical and Dynamical Loads, . .	346	240. Slates,	355
228. Weight of Snow on Roofs, .	347	241. Tiles—Pantiles,	356
229. Wind Pressure on Roofs, .	347	242. Corrugated Iron — Table of Weights, &c.,	356
230. Rafters,	349	243. Zinc Covering—Table of Weights, &c.,	360
231. Main Tie-bars,	350	244. Lead Covering,	362
232. Struts,	350	245. Felt Covering,	362
233. Shoes of Principals, . . .	351	246. Glass,	362
234. Wind-Bracing,	352	247. Ventilation of Buildings, .	363
235. Roof Trusses with Curved Rafters,	352	248. Timber Roofs—Table of Scantlings for Different Spans,	363
236. Arched Ribs,	352		
237. Distance apart of the Prin- cipals,	353		
238. Working Stresses on Roof Trusses,	354		

CHAPTER XX.—DEFLECTION OF GIRDERS—CAMBER OF GIRDERS.

249. Causes which Influence the Deflection of Girders, . . .	365	252. Amount of Camber in Girders,	370
250. Rules for Finding the Deflection,	366	253. Methods of Finding the Ordinates of the Curve, . .	371
251. Deflection of Solid Beams, .	368	254. Camber in Plate Girders, .	372
		255. Camber in Lattice Girders, .	373

CHAPTER XXI.—CONNECTIONS—RIVETTED JOINTS—PROPORTION OF EYES.

256. Different Methods of Join- ing Plates by Rivets, . . .	374	261. Double-Riveted Lap- Joints,	380
257. Rivets in Single and Double Shear,	375	262. Butt-Joints with Single Covers,	302
258. Shearing Strength of Rivets, .	376	263. Butt-Joints with Double Covers,	382
259. Strength of Lap-Joints, . .	377		
260. Proportion of Joints, . . .	379		

Art.	Page	Art.	Page
264. Joints in the Flanges of Girders,	385	267. Proportions of Eyes,	388
265. Joints in a Girder Flange consisting of a number of Plates,	387	268. Rules of American Engineers,	389
266. Method of Connecting Bars by Pins,	387	269. Gibs and Cotters,	390
		270. Proportions of Cotters, &c.,	391

CHAPTER XXII.—PUNCHING—DRILLING—RIVETTING.

271. Methods of Perforating Plates,	392	277. Different Forms of Rivet-Heads,	396
272. Punching—Relative Sizes of Punches and Dies,	393	278. Methods of Forming Rivet-Heads,	398
273. Weakening Effect of Punching and Drilling,	393	279. Rivetting by Hand,	399
274. Punching and Drilling Mild Steel,	395	280. Machine Rivetting—Steam Rivetters—Mechanical Rivetters,	399
275. Increase of Strength Due to Perforation,	396	281. Hydraulic Rivetters,	399
276. Strength of Rivets in Punched and Drilled Holes,	396	282. Pneumatic Rivetters,	400
		283. Pressure Required to Form the Rivet-Head,	400
		284. Strength of Rivets put in by Different Machines,	401

CHAPTER XXIII.—BRIDGES—WORKING LOADS AND STRESSES.

285. Definition of Bridges, Viaducts, Aqueducts, &c.,	402	296. Centrifugal Force,	413
286. Substructure and Superstructure,	403	297. Longitudinal Stresses on Bridges—Effect of Brakes,	414
287. Particulars Requisite for Designing a Bridge,	403	298. Working Stresses on Bridges,	414
288. Dimensions of Bridges,	405	299. Working Stress on Cast-Iron Bridges—Board of Trade Rules,	415
289. Dimensions relating to Railway Bridges,	405	300. Working Stresses on Wrought-Iron Bridges—Board of Trade Rules,	417
290. Loads on Bridges,	405	301. Shearing Stresses on the Webs of Wrought-Iron Bridges,	418
291. Dead Load—Roadway, Platform, Main Girders,	407	302. Working Stresses on Steel Bridges—Board of Trade Rules,	418
292. Live Load upon Public Road Bridges,	407	303. Working Stresses on Timber,	419
293. Live Load on Railway Bridges—Table of Loads,	408		
294. Effect of Loads in Rapid Motion,	411		
295. Side Pressure on Bridges,	413		

CHAPTER XXIV.—BRIDGES (continued)—FOUNDATIONS AND PIERS.

304. Timber Foundations,	419	309. Method of Sinking Screw Piles,	422
305. Cofferdams,	420	310. Piers composed of Screw Piles,	423
306. Caissons,	420	311. Cast-Iron Cylinders,	423
307. Iron Piers,	421		
308. Screw Piles,	421		

CHAPTER XXV.—BRIDGES (*continued*)—SUPERSTRUCTURE.

Art.	Page	Art.	Page
312. Different Varieties of Superstructures, . . .	424	324. Different kinds of Floors for Bridges, . . .	431
313. Cast-Iron Girder Bridges, . . .	425	325. Distance apart of Cross-Girders, . . .	432
314. Wrought-Iron and Steel Girder Bridges, . . .	426	326. Intermediate Bearers, . . .	433
315. Flanges or Booms of Girders, . . .	426	327. Timber Flooring for Roadway, . . .	434
316. Girders made of Different Materials in Combination, . . .	427	328. Iron Flooring, . . .	435
317. Plate Web Girders, . . .	427	329. Strength of Wrought-Iron Flat Road Plates, . . .	436
318. Stiffeners for Web, . . .	428	330. Buckled Plates, . . .	437
319. Rolled Beams, . . .	429	331. Strength of Buckled Plates, . . .	439
320. Box Girders, . . .	429	332. Patent Trough and Corrugated Flooring, . . .	439
321. Lattice Girders, . . .	430	333. Lindsay's Patent Troughs—Table of Sections, . . .	439
322. Platforms of Bridges, . . .	430		
323. Method of Attaching the Platform, . . .	431		

CHAPTER XXVI.—BRIDGES (*continued*)—SUSPENSION BRIDGES.

334. Definition, . . .	443	339. Stresses on the Horizontal Member, . . .	449
335. Chain Uniformly Loaded, . . .	445	340. Main Chains, . . .	451
336. Method of Attaching the Main Chains to the Piers, . . .	446	341. Advantages of Suspension Bridges, . . .	453
337. Stresses on Suspending Rods, . . .	448	342. Disadvantages of Suspension Bridges, . . .	453
338. Suspension Bridges with Sloping Rods—Dredge's System, . . .	448	343. Stiffening Suspension Bridges, . . .	454

CHAPTER XXVII.—BRIDGES (*continued*)—MOVABLE BRIDGES.

344. Definition, . . .	456	348. Classification of Swing Bridges, . . .	458
345. Different kinds of Movable Bridges, . . .	456	349. Traversing Bridges, . . .	459
346. Bascules, . . .	457	350. Lifting Bridges, . . .	459
347. Swing Bridges, . . .	457	351. Pontoon Bridges, . . .	459

CHAPTER XXVIII.—BRIDGES (*continued*)—WEIGHT OF BRIDGES.

352. Importance of knowing Approximate Weight of Bridge before making the Design, . . .	459	354. Weight of Railway Bridges under 200 feet span, . . .	461
353. Weight of Girders under 200 feet span, . . .	460	355. Long Span Railway Bridges—Relative Economy of different Types, . . .	461

CHAPTER XXIX.—WIND PRESSURE ON STRUCTURES.

Art	Page	Art	Page
356. Importance of Wind-Pressure on Structures, . . .	463	359. Influence of the form of a Surface as affecting Wind-Pressure, . . .	467
357. Circumstances which Influence Wind-Pressure, . . .	463	360. Wind-Bracing, . . .	467
358. Relationship between the Velocity and Pressure of the Wind, . . .	464	361. Stresses on Braced Piers, . . .	467

CHAPTER XXX.—LIFTING TACKLE—ERECTION OF BRIDGES, &c.

362. Derricks, . . .	470	371. Erection of Small Bridges, . . .	477
363. Sheer Legs, Tripods, and Scotch Cranes, . . .	471	372. Erection of Large Bridges, . . .	477
364. Ropes and Chains, . . .	471	373. Erection upon Staging, . . .	478
365. Preserving Ropes, . . .	473	374. Erection by Floating Girders, . . .	478
366. Chains—Close Link and Studded Link Chains, . . .	473	375. Erection by Protrusion or Rolling Over, . . .	479
367. Fatigue of Chains, . . .	473	376. Erection by Overhanging or Building Out, . . .	480
368. Ultimate Stress—Proof Stress and Working Stress on Chains, . . .	474	377. Cost of Erection, . . .	481
369. Weight of Chains, . . .	475	378. Erection of Iron Roofs and Buildings, . . .	481
370. Different Systems of Erecting Bridges, . . .	476		

CHAPTER XXXI.—ENGINEERS' SPECIFICATIONS OF IRON AND STEEL BRIDGES.

Manchester, Sheffield, and Lincolnshire Railway, . . .	483	Lancashire and Yorkshire Railway, . . .	486
Cast-Iron Work, . . .	483	Wrought-Iron Work, . . .	486
Wrought-Iron Work, . . .	484	Cast-Iron Work, . . .	487
Steel, . . .	486	Steel, . . .	488
Maintenance, . . .	486		

INDEX,	489
------------------	-----

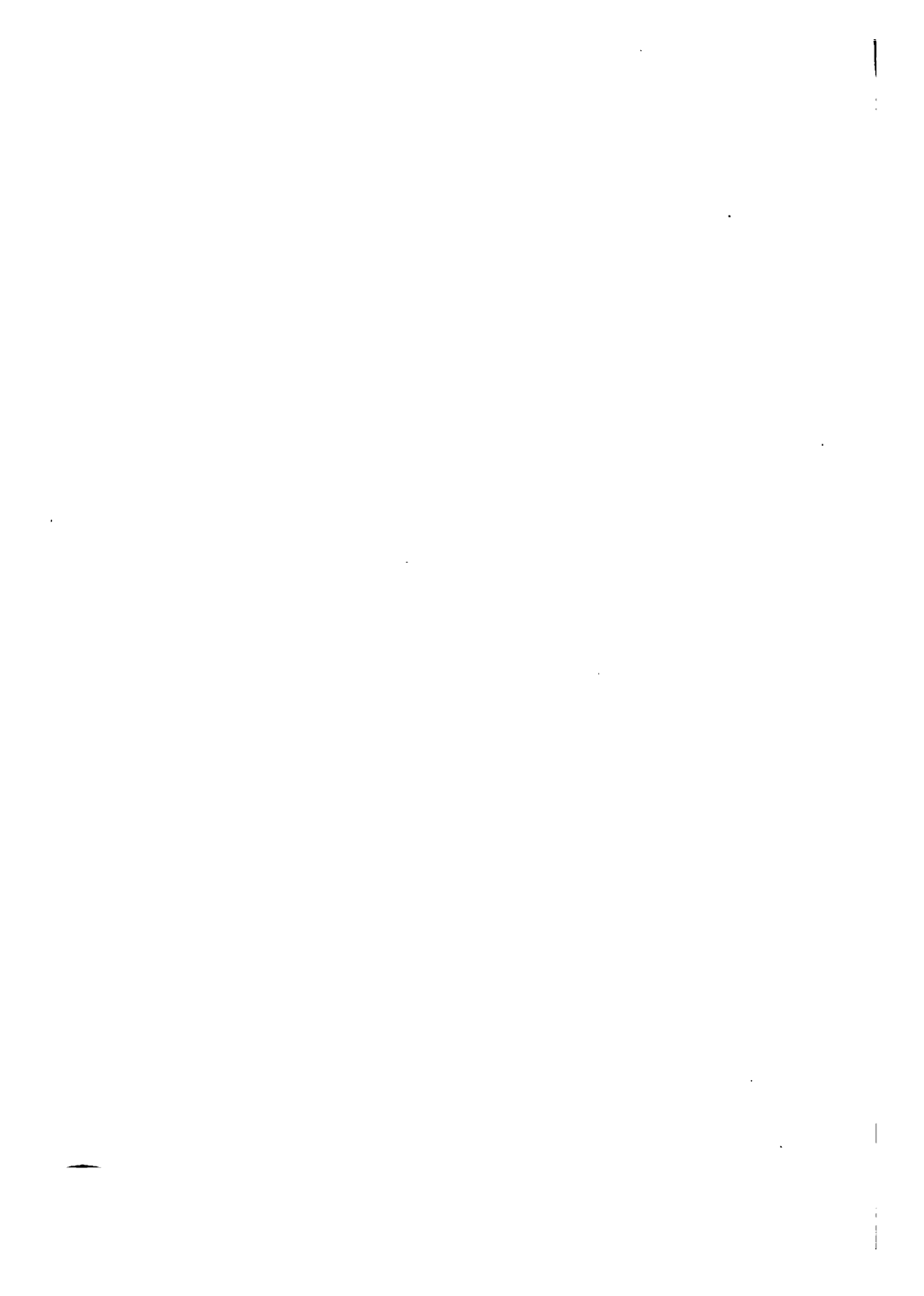

LIST OF TABLES.

TABLE	PAGE
I. Weight of materials,	8-10
II. Moduli of elasticity of different materials,	14
III. Ratios between ultimate strength, proof strength, and working loads of different materials,	18
IV. Wöhler's experiments on the fatigue of iron and steel,	24
V. Do. do. do.,	24
VI. Strength of timber (compressive and tensile),	26
VII. Major Wade's experiments on the relative strengths of small and large castings,	29
VIII. Tensile and transverse strengths of cast iron,	30
IX. Tensile strength of wrought iron—Average results of 587 experiments by Mr. Kirkaldy,	32
X. Strength of wrought iron, as used in bridge-work,	33
XI. Experiments on shearing wrought-iron bars with parallel cutters,	35
XII. Coefficients of linear expansion by heat,	3
XIII. Strength of annealed and un-annealed steel plates,	40
XIV. Strength of steel ingots subjected to hydraulic pressure from test-pieces cut longitudinally,	41
XV. Strength of steel ingots subjected to hydraulic pressure from test-pieces cut transversely,	41
XVI. Supporting forces on continuous beams,	65
XVII. Positive and negative maximum shearing stresses on the main girders of a railway bridge 200 feet span during the passage of a train,	134
XVIII. Moduli of rupture (f) of beams of different sections and of different materials,	164
XIX. Experiments on the transverse strength of square bars of cast iron broken on their sides,	166
XX. Do. do. do.,	166

TABLE	PAGE
XXI. Experiments on the transverse strength of square bars of cast iron broken on their angle,	167
XXII. Experiments on the transverse strength of cast-iron solid cylindrical bars,	167
XXIII. Do. do. do.,	168
XXIV. Experiments on the transverse strength of cast-iron beams of H-section,	168
XXV. Weights and strengths of rolled joints of iron and steel,	186
XXVI. The 3 ⁵ th power of different numbers (d^{35}),	192
XXVII. The 1 ⁶³ rd power of different numbers (d^{163}),	193
XXVIII. Breaking weight in tons per square inch of solid or hollow cast-iron columns, the ends being securely fixed, by Hodgkinson and Gordon's rules,	202
XXIX. Values of the square of the radii of gyration for different sections,	204
XXX. Experiments on wrought-iron hollow cylindrical columns,	208
XXXI. Average results of Mr. Christie's tests of wrought-iron struts of angle and tee sections,	211
XXXII. Average results of Mr. Christie's tests of steel struts of angle and tee sections, the ends being flat,	212
XXXIII. Stresses on Warren girder loaded with three weights,	241
XXXIII a. Do. do. uniformly loaded,	243
XXXIII b. Do. do. do.,	244
XXXIV. Do. do. do.,	247
XXXV. Do. do. loaded with three weights,	249
XXXVI. Stresses on the diagonals of a Warren cantilever uniformly loaded,	253
XXXVII. Stresses on the flanges of a Warren cantilever uniformly loaded,	254
XXXVIII. Stresses on the diagonals and flanges of a Warren cantilever uniformly loaded,	255
XXXIX. Stresses on the diagonals of a Warren girder with vertical bracings,	257
XL. Stresses on lattice girders without vertical bracings,	261
XXI. Do. with do.	261
XLII. Flange stresses on Linville truss loaded with single weight at the centre,	263
XLIII. Flange stresses on Linville truss loaded with single weight at any point,	264

LIST OF TABLES.

TABLE	PAGE
XLIV. Stresses on a Linville truss loaded with a single weight,	265
XLV. Do. do. when loaded with two weights,	265
XLVI. Stresses on a Linville truss with an even number of bays, and loaded uniformly,	268
XLVII. Stresses on a Linville truss when the number of bays is odd,	268
XLVIII. Stresses on a Linville truss when loaded along the bottom flange,	270
XLIX. Stresses on a Linville truss when the load rests on the top flange,	272
L. Stresses on a Linville truss with uniformly distributed dead and rolling loads,	274
LI. Maximum stresses on a Linville truss during the passage of a single rolling load,	275
LII. Stresses on bowstring girder with single load resting on the middle of the bottom flange,	279
LIII. Stresses on bowstring girder with two loads resting on the bottom flange,	281
LIV. Stresses on the flanges of a bowstring girder loaded uniformly,	283
LV. Stresses on the bracing of a bowstring girder loaded uniformly,	283
LVI. Stresses on bowstring girder loaded uniformly with live and dead loads,	285
LVII. Stresses on bowstring girder when the live load covers half the girder only,	285
LVIII. Stresses on fish-bellied girder loaded with uniform live and dead loads,	287
LIX. Stresses on fish-bellied girder when live load covers half the girder only,	287
LX. Stresses on a braced curved girder loaded with a single weight at its centre,	290
LXI. Stresses on a braced curved girder uniformly loaded,	291
LXII. Stresses on a braced crane,	306
LXIII. Stresses on a braced arch for a central load,	316
LXIV. Stresses on roof truss of 35 feet span loaded uniformly,	323
LXV. Do. do. with an additional load on the left slope,	324

TABLE	PAGE
LXVI. Stresses on roof truss of 90 feet span uniformly loaded,	326
LXVII. Do. do. 50 feet span, loaded uniformly and also exposed to wind-pressure,	328
LXVIII. Stresses on cantilever roof truss loaded with dead load and also with wind-pressure,	330
LXIX. Stresses on roof truss, 45 feet span, loaded uniformly, and also with snow on one slope,	332
LXX. Stresses on roof truss, 35 feet span, loaded uniformly,	333
LXXI. Do. 50 do.	334
LXXII. Do. loaded with snow on one slope, .	335
LXXIII. Stresses on French truss, 70 feet span, loaded uni- formly,	337
LXXIV. Stresses on saw-tooth roof truss, 20 feet span, loaded uniformly,	338
LXXV. Stresses on composite roof truss,	339
LXXVI. Stresses on bowstring roof truss, 55 feet span, . . .	341
LXXVII. Stresses on curved roof truss, 100 feet span, loaded uniformly,	344
LXXVIII. Stresses on curved roof truss with additional loads, .	344
LXXIX. Weight of roof-principals of different spans, . . .	347
LXXX. Wind-pressure on roofs of different slopes,	348
LXXXI. Weights of different materials for roof-coverings with minimum angles of slopes,	355
LXXXII. Sizes and weights of corrugated sheeting for roof- covering,	358
LXXXIII. Gauge and weight of zinc sheets for roof-covering, . .	361
LXXXIV. Weights per square of zinc-covering for roof, . . .	362
LXXXV. Sizes of scantlings for timber roof trusses from 20 to 30 feet span,	364
LXXXVI. Sizes of scantlings for trusses from 30 to 46 feet span,	364
LXXXVII. Do. do. 46 to 60 do.,	365
LXXXVIII. Proportions of eye-bars (American practice), . . .	390
LXXXIX. Safe working stresses in cotters, &c.,	392
XC. Mr. Parker's experiments on punched and drilled wrought-iron plates,	394
XCI. Strength of steel rivets put in by different machines, .	401
XCII. Dimensions relating to railway bridges,	406
XCIII. Weights of metalling for road bridges,	407
XCIV. Weight and distribution of railway locomotives, . . .	409

LIST OF TABLES.

xxiii

TABLE	PAGE
XCV. Live loads per lineal foot on railway bridges of different spans (Baker),	409
XCVI. Do. do. (English practice),	410
XCVII. Do. do. (Stoney),	411
XCVIII. Weight of flooring in railway bridges,	431
XCIX. Weight of cross-girders and rail-bearers in railway bridges,	433
C. Weight, strength, and cost of iron flooring for bridges,	438
CI. Size, weight, and strength of Lindsay's steel troughs for flooring,	441
CII. Relationship between the velocity and the pressure of the wind,	465
CIII. Strength and weight of hemp ropes,	472
CIV. Working strength and weight of hemp ropes,	472
CV. Strength and weight of chains,	475
CVI. Strength and weight of studded link cables,	476

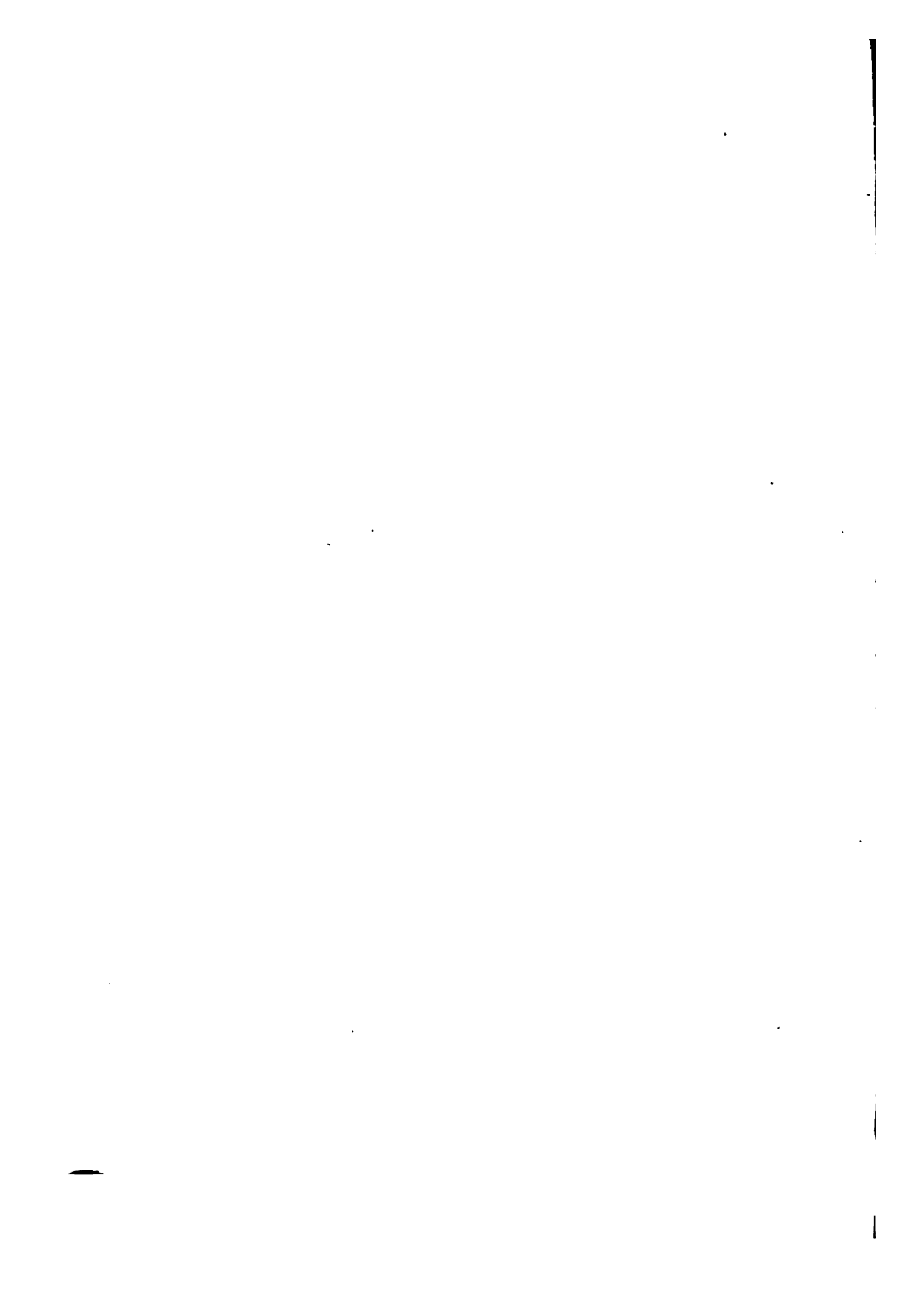

DESIGN OF STRUCTURES.

CHAPTER I.

STRESSES AND STRAINS.

1. **Framed Structures.**—A framed structure in wood, iron, or steel is generally understood to be an assemblage of different members composed of these materials, which are joined together by straps, bolts, pins, or rivets, and arranged in such a manner as best to contribute to the stability of the structure itself; and of such form and dimensions as are best adapted to withstand the various stresses and strains to which they may be subjected from the application of external loads or forces.

This is a definition altogether from a utilitarian point of view. Other considerations from an æsthetic standpoint have their weight in determining the best form of a structure; it usually being desirable to produce something which shall be pleasing to the eye and in harmony with the surroundings.

2. The constituent parts of a structure have various names; but so far as the kinds of stresses produced in them are concerned, they may be grouped under the terms *beams*, *struts*, and *ties*, or some combination of these.

Some of the more common forms of structures are girders, bridges, roofs, piers, ships, and buildings of various descriptions.

When a structure is exposed to weights or loads, stresses are produced in its different constituent members, and it is the province of the engineer to determine the nature and intensity of these stresses, and so to arrange and proportion the members as best to withstand them, due regard being had to economy and artistic effect.

3. **External Loads on Structures.**—By the load on a structure

is meant all the external forces acting upon it. These include:—

(1) *The weight of the structure itself*, which is a constant quantity, and acts vertically.

(2) In bridges and similar structures they include the *weight of the roadway*, which also is constant, and also *the live or moving loads* coming upon them, such as railway trains, vehicular and pedestrian traffic, &c., which vary in amount. All these forces act vertically.

(3) *Wind pressure*, which affects all exposed structures. This is a variable force acting horizontally or nearly so, and in some cases is the most important of all the external forces.

4. Stresses and Strains.—All members of a loaded structure, except those inserted for ornament, are exposed to stresses and strains. These two terms are often used indiscriminately as meaning the same thing; strictly speaking, however, this is not so, and in this work each term will (as far as possible) be used in its proper sense. Generally speaking, they represent cause and effect.

A *strain* is a change of form. When an external force acts upon a bar of any material, it produces in it a change of form, no matter how minute. It may elongate it, or shorten it, or bend it. This change of form is termed a "strain." Strains may be temporary or permanent. If, after the force be removed, the bar regain its original shape and dimensions, the strain on its fibres will only be *temporary*, and only last during the application of the force. If, on the other hand, the bar do not regain its original shape and dimensions after the removal of the force, it is said to be *permanently* strained.

By a *stress* is meant the internal force or resistance set up in the fibres of the bar in opposing the strain.

The stresses in materials are proportional to the strains, so long as there is no permanent alteration in the form of the body acted upon.

There are three kinds of stresses and strains:—

- (1) *Compressive* or *positive* stresses and strains.
- (2) *Tensile* or *negative* stresses and strains.
- (3) *Shearing* stresses and strains.

If a bar of any material be acted upon by two *equal* forces applied at its extremities, and acting *away* from each other in the direction of its length, it becomes *extended*, and the strains produced in the fibres are said to be *tensile* or *negative* strains.

The stresses or resistance to the straining action on the fibres are, in like manner, termed tensile or negative stresses.

If, on the other hand, the bar be acted upon by two equal forces acting *towards* each other, it becomes *shortened*, and the strains and stresses generated are termed *compressive* or *positive* strains and stresses.

A tensile stress on a bar tends to cause its failure by lengthening and ultimately *tearing* apart its fibres; a compressive stress induces failure by shortening and ultimately *crushing* its fibres; and a shearing stress produces failure by causing one part to slide across the other, or by *cutting* it across.

Besides these three kinds of stresses, there are others which are frequently to be met with, the most common of which are *transverse* or *bending* stresses and *torsional* or *twisting* stresses, with their corresponding strains; but these and other forms, as will subsequently be shown, may be resolved into one or more of the three elementary forms named.

5. Measurement of Stresses and Strains.—In England and where English standards are adopted, a stress is measured by so many pounds, cwts., or tons. A *unit stress* is usually measured by so many pounds, cwts., or tons per square inch of sectional area of the body under stress. According to the French standards of measurements, the unit of stress is reckoned as so many kilogrammes per square centimetre. If the stress on a bar of iron 2 inches square be 50 tons, the unit stress, or stress per square inch, will be 12.5 tons. The corresponding unit stress in French measure is 1,968 kilogrammes per square centimetre.

A strain is usually measured in inches or parts of an inch. A unit strain is measured in parts of an inch per lineal foot of the bar under strain, or it may be measured as so much per cent. of the length of the bar. If a bar of steel 2 feet long, under a certain tensile stress, be lengthened by half an inch, the strain produced is equal to $\frac{1}{4}$ -inch per foot, or 2.08 per cent. of the length of the bar.

6. Tensile Stress.—Fig. 1 is an example of tensile stress. A bar, *a b*, of section *A* square inches, is suspended at one extremity, *a*; and a weight of *W* tons is hung from the other end, *b*. The bar under these conditions is said to be subjected to a tensile stress of *W* tons throughout its entire length, or to

a unit stress of $\frac{W}{A}$ tons.

7. Compressive Stress.—Fig. 2 is an example of compressive stress. A pillar rests on the ground, and a weight of *W* tons rests on the top. The pillar is under a compressive stress of *W* tons, and if *A* = its sectional area in square inches, the fibres are

subjected to a compressive stress of $\frac{W}{A}$ tons per square inch throughout its entire length.

8. Shearing Stress.—Figs. 3 and 4 are examples of shearing stresses. Two links of iron or steel are joined together by a pin of the same material, and are exposed to forces of W tons acting in the directions of the arrows.

In both cases the pin is subjected to a shearing stress. In fig. 3 the pin is exposed to a *single* shearing stress of W tons at its section, $a b$, and is said to be in *single shear*, and if A = number of square inches in its sectional area, the shearing stress per square inch on the pin = $\frac{W}{A}$ tons.

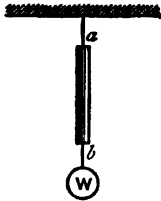

Fig. 1.



Fig. 2.



Fig. 3.



Fig. 4.

In fig. 4 the pin is exposed to a *double* shearing stress at its sections, $a b$, and $c d$, and is said to be in *double shear*. The shearing stress at each section is equal to $\frac{W}{2}$ tons, and if A_1 = sectional area of the pin, the shearing stress per square inch upon it = $\frac{W}{2 A_1}$. From this it is apparent that the sectional area of the pin in fig. 4 need only be one half of that in fig. 3, in order to be of equal strength.

9. Transverse Stress.—Fig. 5 is an example of *transverse* or *bending* stresses. The beam, $A B$, rests on two supports at A and B , and is loaded at an intermediate point by a weight, W ; the beam in this condition is said to be exposed to a bending or transverse stress; but, as will be shown in a future chapter, the fibres in the upper portion of the beam are subjected to a compressive stress, and those in the lower portion to a tensile stress, while shearing stresses also come into operation throughout the beam.

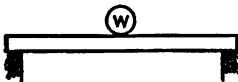

Fig. 5.

10. Torsional or twisting stresses do not often occur in the members of structural work ; but they are to be met with in the shafting of machinery of all descriptions.

It is usually assumed that the stress on a bar is uniformly distributed over the whole cross-section of the bar. This is generally true as regards tensile and compressive stresses so long as the bar is of a compact form. It is only approximately true, however, when applied to shearing stresses, and the form of the pin or bar exposed to this stress has something to do with this want of uniformity. It has been found from experiments that the maximum intensity of shearing stress on a round pin is somewhat greater than the mean intensity, and with a pin of a square or rectangular section, the difference is greater still. For all practical purposes, however, it may be assumed that the stress is uniformly distributed over the section. This being so, if

f = unit stress, or number of lbs. or tons per square inch of section of the bar.

a = number of square inches of sectional area of the bar.

F = total stress in lbs. or tons on the bar.

$$\text{Then } F = af \quad . \quad . \quad . \quad (1).$$

Example 1.—If the ultimate tensile strength of mild steel be 32 tons per square inch, what force will be necessary to tear asunder a bar of this material 4 inches in diameter ?

Here $f = 32$ tons, $a = \pi \times (2)^2 = 3.1416 \times 4 = 12.56$ sq. ins.

Substituting these values of f and a in equation (1), we get

$$F = 32 \times 12.56 = 402 \text{ tons,}$$

which is the tensile force necessary to rupture the bar.

Example 2.—What force will crush a short column of cast iron, 8 inches in external, and 6 inches internal diameter, the ultimate compressive strength of the metal being 40 tons per square inch ?

$f = 40.$

a = sectional area of column = $\pi \{ (4)^2 - (3)^2 \} = 22$ sq. inches.

Required force $F = 22 \times 40 = 880$ tons.

Example 3.—If the bars shown in fig. 3 be pulled with a

force of 50 tons acting in opposite directions, what must be the diameter of the pin so that the shearing stress on it may be equal to 10 tons per square inch?

Let d = required diameter.

We have then $a = .7854 d^2$. $f = 10$. $F = 50$.

From equation (1) we have, by transposing,

$$a = \frac{F}{f}, \text{ or } .7854 d^2 = \frac{50}{10} = 5.$$

$d^2 = 6.36$, or $d = 2.5$ inches, the required diameter.

Example 4.—In the last example, if the pin be in double shear as shown in fig. 4, what must be its diameter in order to fulfil the same conditions?

Using the same notation we get

$$\begin{aligned} a &= 2 \times .7854 d^2. \\ 2 \times .7854 d^2 &= 5, \text{ or } d^2 = 3.18. \\ d &= 1.79 \text{ inches.} \end{aligned}$$

Example 5.—If a rectangular tie-beam of oak, 6 inches by 4 inches, be subjected to a tensile stress of 50 tons, what will be the stress per square inch exerted on its fibres?

$$F = 50. \quad a = 6 \times 4 = 24 \text{ sq. inches.}$$

$$f = \frac{F}{a} = \frac{50}{24} = 2.08 \text{ tons per sq. inch.}$$

Example 6.—A bar of wrought iron of any uniform section is suspended from one end, and hangs vertically, what must be its length so as to break by its own weight, the ultimate strength of the iron being 20 tons per square inch, and the weight of a cubic inch being 0.28 lbs.?

Let l = length of the bar in feet.

a = its section in square inches.

$$\left. \begin{array}{l} \text{Breaking weight of} \\ \text{the bar in pounds} \end{array} \right\} = 20 \times 2240 \times a.$$

$$\left. \begin{array}{l} \text{Weight of bar in} \\ \text{pounds} \end{array} \right\} = 12 \times .28 \times a \times l = 3.36 a l.$$

These two expressions must be equal to each other, or

$$3.36 \times a \times l = 44,800 \times a.$$

$$\text{or } l = 13,333 \text{ feet.}$$

It will be seen from this that the section of the bar does not affect the length under the conditions stated.

Example 7.—Two round steel bars, each of 2 inches diameter, are joined together by means of a steel pin in the manner shown in fig. 4. If the ultimate strength of the steel to resist tension be 30 tons per square inch, and its ultimate shearing strength be 24 tons per square inch, what must be the diameter of the pin so as to be equal in strength to the bars ?

Let d = required diameter.

$$\left. \begin{array}{l} \text{Strength of pin to resist} \\ \text{shearing} \end{array} \right\} = 2 \times 24 \times .7854 d^2 = 37.7 d^2 \text{ tons.}$$

$$\text{Tensile strength of bars} = 30 \times .7854 \times (2)^2 = 94.248 \text{ tons.}$$

These two expressions, according to the conditions of the question, must be equal to each other, or

$$37.7 d^2 = 94.248,$$

$$\text{or } d = 1.58 \text{ inches,}$$

which is the required diameter of the pin.

11. Long Struts.—The rule embodied in the formula $F = af$, does not hold when applied to compressive stresses, if the diameter of the bar or column is small in proportion to its length. Long bars when subjected to a compressive stress in the direction of their length do not break entirely by crushing. They have a tendency to become deflected laterally, and to break partially by cross-fracture.

This happens in bars made of iron or steel when the length of the bar is more than five times its diameter, or least thickness; and in the case of wood when the proportion exceeds 10 to 1.

Members of this kind are termed "long struts," and their strengths will be investigated in Chapter XI.

TABLE I.—WEIGHT OF MATERIALS (*Molesworth*).

METALS.	Specific gravity.	Weight of a	Weight of a
		cubic inch.	cubic foot.
		lbs.	lbs.
Copper, cast,	8·607	0·310	537·3
Iron, cast, from,	7·0	0·252	437·0
„ „ to,	7·6	0·273	474·4
„ „ average,	7·23	0·26	451·0
„ wrought, from,	7·6	0·273	474·4
„ „ to,	7·8	0·281	486·9
„ „ average,	7·78	0·28	485·6
Lead, cast,	11·36	0·408	708·5
Mercury,	13·596	0·491	848·75
Steel,	8·0	0·288	499·0
Tin, cast,	7·291	0·262	455·1
Brass, cast,	8·4	0·30	524·4
Gun-metal, 10 copper, 1 tin,	8·464	0·306	528·36
TIMBER.			
Ash, from,	0·69	0·025	43·0
„ to,	0·76	0·027	47·0
Beech, from,	0·69	0·025	43·0
„ to,	0·696	0·025	43·0
Cork,	0·240	0·008	15·0
Deal, Christiania,	0·689	0·025	43·0
Elm, English, from,	0·553	0·02	34·0
„ „ to,	0·579	0·021	36·0
„ Canadian,	0·725	0·026	45·0

TABLE I.—WEIGHT OF MATERIALS (*Continued*).

TIMBER (<i>Continued</i>).	Specific gravity.	Weight of a	Weight of a
		cubic inch.	cubic foot.
		lbs.	lbs.
Fir, Spruce,	0·512	0·018	32·0
Larch, from,	0·543	0·019	34·0
„ to,	0·556	0·02	35·0
Oak, African,	0·988	0·035	62·0
„ American, red,	0·850	0·030	53·0
„ „ white,	0·779	0·028	49·0
„ English, from,	0·777	0·028	48·0
„ „ to,	0·934	0·034	58·0
Pine, red, from,	0·576	0·021	36·0
„ „ to,	0·657	0·024	41·0
„ white, from,	0·432	0·015	27·0
„ „ to,	0·553	0·020	34·0
STONES, &c.			
Basalt, Scotch,	2·95	0·106	184
Chalk, from,	2·33	0·084	145
„ to,	2·62	0·094	162
Granite, Aberdeen,	2·62	0·095	165
Limestone, Compact,	2·58	0·093	161
„ Purbeck,	2·6	0·093	162
„ Blue Lias,	2·467	0·089	154
Sandstone, Arbroath pavement,	2·477	0·089	155
„ Yorkshire paving,	2·51	0·09	157
Slate, Welsh,	2·88	0·104	180

TABLE I.—WEIGHT OF MATERIALS (*Continued*).

MISCELLANEOUS SUBSTANCES.	Specific gravity.	Weight of a cubic inch.	Weight of a cubic foot.
		lbs.	lbs.
Asphalte,	2·5	0·09	156
Brick, common, from,	1·6	0·057	100
„ „ to,	2·0	0·072	125
„ London stock,	1·84	0·066	115
„ red,	2·16	0·077	134
Cement, Portland, in powder, from,	3·1	0·05	86
„ „ „ to,	3·155	0·054	94
Clay,	1·9	0·068	119
Coal, anthracite,	1·53	0·055	95
„ cannel,	1·272	0·046	79
Coke,	0·744	0·026	46
Earth, from,	1·52	0·054	77
„ to,	2·0	0·072	125
Glass, flint,	3·078	0·111	192
Mortar, from,	1·38	0·049	86
„ to,	1·9	0·068	119
Pitch,	1·15	0·041	69
Sand, quartz,	2·75	0·099	171
„ river,	1·88	0·67	117

CHAPTER II.

ELASTICITY AND FATIGUE OF MATERIALS.

12. **Elasticity.**—There are other properties of materials which make them valuable for structures besides their tensile, compressive, and shearing strengths. One of the principal of these is *elasticity*.

Elasticity is the term applied to that property which materials possess of returning to their original size and shape after they have been strained; and a material is said to be *elastic* if the strain disappears after the stress has been removed.

When a gradually-increasing tensile stress is applied to a bar of iron, steel, or other material, it becomes elongated or stretched, and the amount of this elongation, or *increment* of length, within certain limits, is proportional to the stress applied. The same law holds good if the bar is subjected to a compressive stress. In this latter case the bar is shortened, and the amount of shortening, or *decrement* of length, is proportional to the stress within the limits named. This principle is known as *Hooke's law of uniform elastic reaction*, or the *law of elasticity*, to which the discoverer applied the Latin phrase "*Ut tensio sic vis.*"

The truth of this law has been proved by more than one experimenter. The late Mr. Hodgkinson instituted an elaborate series of experiments on cast and wrought iron, subjecting these materials both to compressive and tensile stresses, and the results he obtained practically prove the truth of the above law, so far as these materials are concerned.

13. **Limits of Elasticity.**—The limits of stress, between which bodies are elastic, are termed their *limits of elasticity*. The range of these limits is very much greater in some materials than in others. Lead, for example, has little or no elasticity. If it be strained to any appreciable extent, it will be found that when the stress which produces the strain is removed, the strain itself does not suffer any appreciable diminution. Lead, therefore, may be called a *non-elastic substance*. On the other hand, glass is very elastic. If it be strained just up to its breaking-point, when the stress is removed, it regains its original dimensions. Iron and steel occupy a position intermediate between lead and glass as regards their elasticity. They are elastic, or nearly so, up to about one-half of their ultimate strength. When a body

under stress passes its elastic limit, the increments or decrements of length increase at a much more rapid rate until finally rupture takes place.

14. **Elasticity a Measure of Strength.**—The elasticity of a material as used in a structure is a very important measure of its quality, even more so than its ultimate compressive or tensile strength.

15. **Modulus of Elasticity.**—

Let L = length of a bar in inches ;

P = stress applied to it in tons per square inch ;

l = increment or decrement of length in inches arising from the stress P .

From Hooke's law, when P varies, l will vary in the same proportion, so that the expression $\frac{P \times L}{l}$ is a constant quantity for all values of P within the elastic limits of the material. This expression is termed the *modulus of elasticity* of the material, and is usually represented by the symbol E . Consequently we have

$$E = \frac{P \times L}{l} \quad . \quad . \quad . \quad (1).$$

In this equation, if we put $L = l$, we get $E = P$, so that the modulus of elasticity may also be defined as that tensile force in tons per square inch which, if applied to a bar, will double its length, on the assumption that the material is perfectly elastic up to this point. Of course, it is unnecessary to remark that no structural material with which we are acquainted fulfils this condition.

16. **Methods of Determining the Modulus of Elasticity.**—The modulus of elasticity may be determined without much difficulty for different materials in three different ways :—

(1) By exposing a bar of the material to a direct compressive stress, and observing the decrement of length.

(2) By exposing the bar to a direct tensile stress, and observing the increment of length.

(3) By exposing a beam of the material to a transverse stress, and observing the deflection.

The modulus, as determined by these three methods, is sometimes different. It has been found for most materials that the compressive modulus is different from the tensile modulus, and that found by transverse stress different from both. For wrought

iron and cast iron the tensile modulus is greater than the compressive modulus, which shows that these materials yield more to compression than extension.

The moduli, as found by the first and second methods, are calculated by the aid of equation (1).

As an illustration, suppose we take a bar of wrought iron, 20 feet long and 1 square inch in section, and expose it to a tensile stress of 1 ton, it will be found to be elongated by about $\frac{1}{80}$ part of an inch. We have here all the data necessary for determining the tensile modulus of elasticity of the iron.

$$L = 20 \times 12 = 240 \text{ inches. } l = \cdot 02 \text{ inches. } P = 1 \text{ ton.}$$

Substituting these values in equation (1) we get

$$E = \frac{1 \times 240}{\cdot 02} = 12,000 \text{ tons.}$$

No two bars of the same material will give precisely the same results. This is not to be wondered at, considering that the least irregularity or flaw in the fibres, or even the manner in which the stress is applied, will vary the result considerably.

The following is the method of finding the modulus of elasticity by transverse stress. Take a rectangular beam of the material, and lay it on two supports, and load it at the centre.

- Let l = span of the beam in inches.
 b = breadth of beam in inches.
 d = depth " "
 W = weight in lbs. applied at the centre.
 δ = central deflection of the beam in inches.
 E = modulus of elasticity in lbs.

We have the following expression for determining E —

$$E = \frac{W l^3}{4 b d^3 \delta} \quad . \quad . \quad . \quad . \quad (2).$$

This rule assumes that the material in the top of the beam is compressed by the same amount that it is extended at the bottom, or that E is the same for compression as for tension.

17. Deflection of Beams.—From equation (2) the central deflection of rectangular bars or beams of different materials by a central load may be determined, when the modulus of elasticity is known.

We get by transposing

$$\delta = \frac{W l^3}{4 E b d^3} \quad . \quad . \quad . \quad (3).$$

TABLE II.—MODULUS OF ELASTICITY.

E = modulus of elasticity in tons; one inch being the unit of area.
W = weight in tons each square inch will bear without producing a perceptible permanent set.

	E.	W.
Cast iron, average,	6,250	6·8
Wrought-iron plates, with the fibre, . .	11,000	...
,, ,, across ,, . . .	12,000	...
,, average,	11,600	9·5
,, bars,	13,000	10·5
Mild steel,	13,200	16·0
Cast steel, tempered,	16,000	29·0
Ash,	732	1·7
Beech,	600	1·4
Elm,	500	1·3
Oak,	650 to 800	1·8
Red pine,	800	2·0

Example 1.—A rectangular bar of wrought iron, 3 inches wide by 4 inches deep, rests on two supports 6 feet apart. What will be the deflection of the bar if a load of $1\frac{1}{2}$ tons be hung from the centre, the modulus of elasticity of the iron being 12,000 tons?

Here we have

$$b = 3". \quad d = 4". \quad l = 72". \quad W = 1\cdot5 \text{ tons.} \quad E = 12,000 \text{ tons.}$$

Substituting in equation (3), we get the deflection—

$$\delta = \frac{1\cdot5 \times (72)^3}{4 \times 12,000 \times 3 \times (4)^3} = 0\cdot06 \text{ inch.}$$

Example 2.—It was found by experiment that a beam of oak, 12 inches wide by 10 inches deep, placed on two supports 16 feet 8 inches apart, and loaded with 2 tons at the centre, deflected 0.45 inch. What is the modulus of elasticity of the oak?

$$W = 2. \quad l = 200". \quad b = 12". \quad d = 10". \quad \delta = 0.45".$$

Substitute in equation (2), and we find the required modulus—

$$E = \frac{2 \times (200)^3}{4 \times 12 \times (10)^3 \times .45} = 740 \text{ tons.}$$

Knowing the value of E for different materials, it is an easy matter to calculate the amount of elongation or contraction of a bar of any length and section, when acted upon by any longitudinal stress within the limits of elasticity, without going to the trouble of actually testing it.

Let K = section of the bar in square inches, equation (1) then becomes

$$E = \frac{P \times L}{K \times l} \quad . \quad . \quad . \quad (4).$$

From this we get

$$l = \frac{P \times L}{K \times E} \quad . \quad . \quad . \quad (5).$$

Example 3.—By how much will a tensile stress of 30 tons lengthen a round bar of steel, 2 inches in diameter and 20 feet long, the modulus of elasticity of steel being 13,000 tons?

From equation (5) we have

$$l = \frac{30 \times 20 \times 12}{3.1416 \times 13,000} = 0.176 \text{ inch.}$$

Example 4.—If a scantling of beech 2 inches square and 10 feet long be strained $\frac{1}{2}$ inch by a force of 10 tons, what is the modulus of elasticity of the beech?

$$E = \frac{P \times L}{K \times l} = \frac{10 \times 10 \times 12}{4 \times .5} = 600 \text{ tons.}$$

It will be seen from equation (5) that the greater the modulus of elasticity, the less will be the extension or compression of the material for a given stress, and *vice versa*. The modulus for cast iron being considerably less than that of wrought iron or steel, it follows that bars of this material will extend or contract

more than those of wrought iron or steel for the same stress. This explains why a cast-iron girder of given span and depth will deflect more under a load than a similar girder of wrought iron or steel. For the same reason timber beams deflect more than those of iron under similar conditions.

18. *Set*.—When a bar of iron is put into a testing-machine, and exposed to a stress, it becomes elongated or shortened, according to the nature of the stress as already explained. When the stress is removed the bar returns to its original length if it be not strained beyond its elastic limit. If the bar be further strained by a stress beyond its elastic limit, then, when the stress is removed, the bar tends to regain its original length, but does not quite do so. In this case the elasticity of the material is said to be destroyed. The amount of the temporary extension or contraction of the bar in the first case is sometimes called its *temporary set* for the particular stress which produces it. The amount of the permanent extension or contraction in the second case is termed its *permanent set*, or simply "*set*."

Strictly speaking, any stress, however small, produces a permanent set, but its amount is so minute, until the limit of elasticity is reached, that practically it may be ignored.

With wrought iron the limit of elasticity is usually reached when the stress is from 10 to 12 tons per square inch. In good qualities of mild steel it is not reached until the stress is from 18 to 20 tons. In other substances, such as glass, there is no appreciable permanent set whatever, such substances being elastic up to their breaking point.

No member of a structure should on any account be strained beyond its limit of elasticity, for in such case not only will the strength of such a member be permanently impaired, but, on account of its permanent alteration in length, additional stresses will be thrown on adjacent members, which they are not designed to sustain.

It will be readily seen, from what has been said, that it is not advisable to have members of the same framed structure made of different materials when there is much difference between their moduli of elasticity, as, for example, in the case of a timber-beam trussed with iron or steel tension bars. Here, owing to the difference of contraction and extension between the wood and the iron, it is difficult or impossible to calculate with any degree of exactness the amount of stress on the different members.

19. *Ultimate Strength—Working Load—Factor of Safety*.—The *ultimate strength* of a material, is the direct stress which pro-

duces rupture. This is reckoned usually as so many tons per square inch of the section of the material. It is always understood that the section taken is the original section of the bar, and not that at the point of fracture after the bar has been ruptured.

When a bar of iron or steel is strained to the point of fracture by a tensile stress, the area of the section where fracture takes place is considerably contracted, often to the extent of 20 per cent. or even more of its original area. If a bar of 4 square inches of sectional area break with a tensile stress of 84 tons, and the area at the point of fracture be found to be 3 square inches, then the stress per square inch of fractured area is $\frac{84}{3} = 28$ tons, while that of the original section is $\frac{84}{4} = 21$ tons. The strength of the bar is measured by the latter quantity, and not by the former, and it is said to be equal to 21 tons per square inch.

The *working stress* on a member of a structure is the maximum stress to which it is subjected in actual practice. The ratio of the ultimate strength to the working stress is termed the *factor of safety* of the material. In order to determine the proper value of this factor, a number of considerations must be taken into account. A great deal depends on the character of the working load.

1st. The load may be a constant dead load—a dead load being one which is steady and produces no vibration.

2nd. The load may be a live load, or rolling load, such as a crowd of people, or a railway train or waggon passing over a bridge.

3rd. There are cases of intermittent loads, or loads which are repeatedly or suddenly laid on or taken off again, examples of which occur in cranes.

The loads coming on all structures may be referred to one or more of these three different kinds. Most structures with which the engineer has to do are exposed to the first two. All bridges, for example, have to support a dead load, consisting of the weight of the bridge itself, as well as the ballast and metalling; they have also to support a live load, consisting of the ordinary traffic passing over them. Roofs are also exposed to these two kinds of loads, the first including the weight of the framework of the roof along with its covering, and the second consisting of wind pressure.

20. Value of the Factor of Safety.—The factor of safety varies, or ought to vary, with the nature of the working load. For a

structure like a crane, wholly exposed to varying and jerky loads, it ought to be higher than in a structure like a bridge, or a roof, where the working load is made up of a dead and a live load; and still higher than in the case of girders which support the walls and floors of a warehouse.

In fixing the factor of safety, another consideration must be taken into account, and that is the nature of the material itself. Some materials are more reliable than others; for example, wrought iron and steel are more reliable than cast iron.

Some engineers prefer to take the elastic limit of the material, instead of its ultimate strength, as the basis for fixing its factor of safety, and perhaps this is the more intelligent method. Experiments made by the late Sir Wm. Fairbairn, and more recently by Wöhler, confirm this view. This subject is more fully treated in the chapter on Bridges.

21. **Proof Strength.**—Girders, bridges, and other structures are often proved by testing them before they are used for the purposes for which they are intended. The proof load may be a multiple of the breaking load or of the working load. The

TABLE III. (*Rankine*).

	Ult. Strength. + Proof Strength.	Ult. Strength. + Working Load.	Proof Strength. + Working Load.
Strongest steel,	1½
Ordinary steel and wrought iron, steady load, . . }	2	3	1½
Ordinary steel and wrought iron, moving load, . . }	2	4 to 6	2 to 3
Wrought iron rivetted structures,	3	6	2
Cast iron, steady load, . . .	2 to 3	3 to 4	about 1½
„ moving load,	3	6 to 8	2 to 2½
Timber; average,	3	10	3½
Stone and brick,	about 2	{ 4 to 10: } { av. ab. 8 }	av. about 4

proof load of a bridge is taken to be equal to the greatest load which can possibly come on it. In testing girders, whether of

iron or steel, the proof load is usually somewhat more than this. Cases have been known when it has been taken as high as one-half the breaking load, but this should not be allowed, as at this point the limit of elasticity of the material may be reached or even exceeded, and a permanent set and injury to the material may be produced. Some parts of a structure, such, for example, as the links of a suspension bridge, may be exposed to a proof stress as high as once and a-half their maximum working stress.

The foregoing table, drawn up by the late Prof. Rankine, gives (1) the ratios between the ultimate strength and the proof strength; (2) the ultimate strength and the working load; and (3) the proof strength and the working load of different materials exposed to different kinds of loads.

22. Resilience.—When a bar is strained either by a compressive or tensile force, within the elastic limits, the quantity of work done in extending or compressing it is equal to the amount of compression or extension multiplied by the mean stress which produces it. The term "*resilience*" is used to specify the amount of work thus done, when the stress just reaches the elastic limit.

Resilience may also be defined to be *half the product of the stress into the strain*, where the stress and the strain are those produced when the elastic limit is reached.

Let W = stress in pounds applied to a bar so as to strain it just up to its elastic limit.

l = elongation of the bar in feet due to the stress W .

R = resilience of the bar.

$$\text{then } R = \frac{1}{2} W l \text{ foot-pounds} \quad . \quad . \quad (6).$$

The energy thus exerted is stored up in the stretched bar, and if the stress be gradually removed, the bar recovers its normal length, and the energy is recovered.

The work done in stretching a bar may be expressed in a different form. Thus—

Let a = section of the bar in square inches;

P = stress applied in tons per square inch.

Then $W = P a$.

$$\text{From equation (1) we get } l = \frac{P L}{E}.$$

Substituting these values of W and l in equation (6) we get work done in extending the bar by the length l , equal to

$$\begin{aligned} & \frac{1}{2} P a \times \frac{P L}{E}, \\ & = \frac{P^2}{E} \times \frac{a L}{2} = \frac{P^2}{E} \times \frac{1}{2} \text{ volume of bar,} \quad (7) \end{aligned}$$

since $a L =$ volume of the bar.

It follows from this, that the work required to produce a given stress on the bar is directly proportional to the square of the stress and to the volume or weight of the bar, and inversely proportional to the modulus of elasticity of the material composing the bar.

If $F =$ stress per square inch on the bar when its limit of elasticity is reached, we get $P = F$, and the resilience of the bar, or the greatest amount of work that can be done on the bar without injury to its elasticity, may be expressed by

$$R = \frac{F^2}{E} \times \frac{\text{volume}}{2} \quad (8).$$

The quantity $\frac{F^2}{E}$ is called the *modulus of resilience*.

Example 5.—A bar, 1 inch square, is found to extend $\frac{1}{16}$ inch with a stress of 9 tons. Determine the work done in producing the extension in foot-pounds.

$$\text{Work done} = \frac{\frac{1}{2} \times 9 \times 2240 \times \frac{1}{16}}{12} = 52.5 \text{ foot-pounds.}$$

Example 6.—A round bar of steel 10 feet long and 3 inches in diameter, is exposed to a tensile stress of 100 tons. Determine the number of foot-pounds developed in the bar, the modulus of elasticity of steel being 13,000 tons.

The work done may be calculated from equation (6) by making $W = 100$ tons = 224,000 lbs. and $l =$ extension in feet produced by the weight of 100 tons.

We must first find l by means of equation (1).

$$a = \text{sectional area of bar} = .7854 \times (3)^2 = 7.0686 \text{ sq. ins.}$$

$$P = \text{stress in tons per sq. in.} = \frac{100}{7.0686} = 14.15 \text{ tons.}$$

From equation (1)

$$l = \frac{P L}{E} = \frac{14.15 \times 10}{13,000} = 0.0109 \text{ feet.}$$

\therefore work done = $\frac{1}{2} \times 224,000 \times 0.0109 = 1,220$ foot-pounds.

The result may also be arrived at from equation (7).

$$\begin{aligned} \text{Work done} &= \frac{P^2}{E} \times \frac{1}{2} \text{ volume of bar} \\ &= \frac{(14.15)^2}{13,000} \times 2,240 \times \frac{7.0686 \times 10}{2} = 1,220 \text{ foot-pounds.} \end{aligned}$$

Example 7.—If, in the last example, a weight of 120 tons strains the bar to the limit of its elasticity; find the modulus of resilience.

With a stress of 120 tons on the bar, the stress per square inch

$$F = \frac{120}{7.0686} = 17 \text{ tons.}$$

$$\text{Modulus of resilience} = \frac{F^2}{E} = \frac{(17)^2}{13,000} \times 2,240 = 49.8 \text{ inch-lb.-units.}$$

23. Fatigue of Materials.—When a load is suddenly applied to a girder, it produces a momentary deflection much greater than that which would be produced by the same load at rest. In the same way, if we take a bar of wrought iron, whose ultimate tensile strength is equal to 20 tons per square inch, and apply a much less tensile load suddenly, and very often, so as to produce elastic vibrations in the bar, it will be found that this load, though much less than the statical breaking load of the bar, will, after a certain number of applications, produce rupture. If a load of 12 tons per square inch, or little over half the breaking load of the bar, for example, be applied, it will not produce rupture at the first application, nor even when it has been applied a thousand times; but in the long run, if the number of applications be sufficiently numerous, and suddenly imposed, the bar will fail.

This deterioration produced in the fibres of a bar by repeated applications of the load, is known as the *fatigue* of the material.

This tendency to fracture is increased if the bar be subjected alternately to both compressive and tensile strains.

It becomes, therefore, a very important question to determine to what extent the strength of a structure as a whole, or of its individual members is affected by vibratory action.

This subject, as stated, has been investigated by the late Sir Wm. Fairbairn, and more recently and exhaustively by Wöhler. It is generally understood that when wrought iron, even of the toughest and most fibrous quality, is exposed to long and continuous vibration it becomes crystalline in its texture, and its strength is much impaired, so that it will break not only with a stress much less than its original breaking weight, but also much less than the working stresses to which it was previously exposed. This is frequently observed in the chains of cranes; they will fail while carrying a load which they have often carried with safety previously.

24. Experiments on Cast- and Wrought-Iron Bars.—Sir Henry James and Captain Galton subjected cast-iron bars to repeated stresses, corresponding to statical loads of some proportion of the breaking weight, by means of cams, which depressed the bars, and then allowed them to resume their natural position. From these experiments it was found that bars which received 10,000 depressions equal to that produced by one-third of the statical breaking weight, received no apparent injury; as when they were afterwards broken by a statical weight they were found to be as strong as similar bars which had not been treated in this way. Three other bars were subjected to deflections equal to that which would be produced by half the statical breaking weight, and it was found they broke with 490, 617, and 900 depressions respectively.

From these experiments, it seems reasonable to conclude that it is not safe to expose cast-iron bars or girders to repeated deflections equal to that produced by one-half their statical breaking weight, but that they are quite safe when subjected to repeated deflections, no matter how many, equal to that produced by one-third of their breaking weight.

Wrought-iron bars were also experimented upon, and it was found that no perceptible effect was produced on them by 10,000 successive deflections, each being equal to that produced by one-half the statical breaking weight.

The same result, however, does not hold good when wrought-iron rivetted girders are loaded. In order to determine the effect produced on these latter by repeated loads, Sir W. Fairbairn made a number of experiments on a wrought-iron rivetted single-web plate-girder, 20 feet clear span and 16 inches deep. He first exposed it to a series of loads equal to one-fourth of the

calculated breaking weight of the girder, and applied in such a manner as to resemble as nearly as possible the effect produced on the main girders of a bridge by the passage of railway trains. After the girder had undergone above half-a-million changes of load, no visible alteration was observed in it. The load was then increased from one-fourth to two-sevenths of the statical breaking-weight, and was applied another half-a-million of times without apparent injury. After this, the load was increased to two-fifths of the breaking weight, the deflection produced being 0.35 inch against 0.16 and 0.23 inches in the first and second cases respectively; the girder, after sustaining 5,175 applications of the load, broke by the rupture of the bottom flange.

25. *Wöhler's Experiments.*—Wöhler, with the assistance of the German Government, has made very exhaustive experiments on metals, in order to determine the effect of varying and oft-repeated stresses on these materials. His results agree with those of Sir W. Fairbairn where they travel over the same ground, but Wöhler's experiments are more varied and complete, and he has thrown much additional light on the subject. By means of ingeniously-constructed machines, he exposed bars of wrought iron and steel to tensile stresses varying between zero and a fixed quantity, and also to repeated bending and twisting in opposite directions. The loads were applied and removed a great number of times until the bar was broken, or until it proved its ability to withstand the varying stresses an infinite number of times.

With bars subjected to tensile stresses varying between zero and a certain fixed quantity, the general conclusion to be arrived at from his experiments is, that the greatest tensile stress a bar will bear for an indefinite number of times is for iron and steel about one-half its ultimate static breaking stress.

The number of repetitions required to produce rupture is increased if the range through which the stress is varied is reduced.

Wöhler concluded that bars of wrought iron and steel—the static ultimate strength of the iron being 21, and that of the steel 47 tons—would probably bear an infinite number of stress changes between the limits (in round numbers) and the kinds of stress given in Table IV.

It appears from this that a bar will be *strongest* when exposed to varying stresses of the *same kind*, and *weakest* when exposed to stress of *different kinds*—i.e., a pull and a push. The strengths of the three bars in the Table are approximately in the proportion of 1 : 2 : 3. If the members of a structure be exposed to

stresses similar to those on the bars in the Table, which may frequently occur owing to passing loads, there ought to be different factors of safety applied to them, and these factors ought to be in the proportion of 3 : 2 : 1.

TABLE IV.

	STRESS IN TONS PER SQUARE INCH.	
	Wrought iron.	Steel.
From compression to tension, .	+ 7 to - 7	+ 13 to - 13
From tension to no stress, .	13 to 0	22 to 0
From tension to less tension, .	19 to 10½	37 to 16

The average result of the experiments further proves that with bars of wrought iron and steel, which are exposed alternately to compressive and tensile stresses of equal amount, the limiting stress which they will bear for an infinite number of variations of the load, is about equal to one-third of the ultimate static tensile stress.

The principal results alluded to may be summarised in the following Table:—

Let W = ultimate or static strength of the bar.

W_1 = greatest load the bar will bear for an indefinite number of applications.

TABLE V.—BREAKING WEIGHT BY WÖHLER'S EXPERIMENTS.

1. Steady load without variation, . . . $W_1 = W$.

2. Load varying between 0 and W_1 , . . . $W_1 = \frac{W}{2}$.

3. Load varying between + W_1 and - W_1 , . . . $W_1 = \frac{W}{3}$.

A bar may be broken by a still smaller fraction of the static breaking load, if it is alternately bent upwards and downwards.

CHAPTER III.

PROPERTIES OF MATERIALS USED IN STRUCTURES.

26. The principal materials used in structural work, if we except masonry and brick work, are :—

- (a.) Timber.
- (b.) Cast Iron.
- (c.) Wrought Iron.
- (d.) Mild Steel.

A knowledge of some of the leading characteristics of these materials will be useful to the student.

(a.) TIMBER.

27. Variation in the Strength of Timber.—The strength of timber, even of the same kind and from the same tree, is very variable, and is affected by a number of conditions, such as its age, the part of the tree from which it is cut, the nature of the soil in which it is grown, its seasoning, and other considerations. All kinds are most durable when kept dry and exposed to thorough ventilation.

The effect of moisture is to diminish its strength, and in some kinds it causes decay.

When timber is exposed alternately to wetness and dryness, it decays rapidly, more especially if it is in an enclosed situation where there is no ventilation. Special precautions should be taken to preserve it in such situations.

What is termed "*dry rot*" is very destructive to timber, converting it into a dry powder; and, when it has once attacked a building, it is difficult or impossible to arrest its progress.

Timbers which have grown most slowly, which are dark in colour and heavy, are, as a rule, the strongest and most lasting. Woods which have little resin or sap in their pores are also the strongest.

The sap in timber, by its decomposition, accelerates decay: consequently, it is best to fell timber at the season when its sap is not circulating; this occurs in temperate countries in the winter season and in tropical countries in the dry season.

Trees at the age of maturity produce the best timber.

In the case of young trees, the strongest portion is the heart. After a tree passes the age of maturity, the heart-wood begins to deteriorate, and other portions of the trunk are stronger, with the exception of what is termed the sap-wood, which lies next the bark, and is the worst part of the tree.

28. **Seasoning and Preserving Timber.**—The strengths of most timbers are nearly doubled by proper “seasoning” or drying. Seasoning timber consists in expelling the moisture, and may be done either by natural or artificial means. The former method merely consists in stacking it in a dry sheltered place; the seasoning being effected in from two to five years.

There are several methods of artificial seasoning. By the *desiccating* process, the timber is placed in a chamber and exposed to a current of hot air. Other methods consist in impregnating the pores with creosote or metallic salts.

Timber may be protected against moisture, by painting it from time to time with good oil paint; the timber, however, should be dry before the paint is first applied. Pitch and tar are also good preservatives.

TABLE VI.—STRENGTH OF TIMBER.

	TENSILE STRENGTH PER SQUARE INCH.		Crushing Strength per Square Inch.
	With the Grain.	Across the Grain.	
	lbs.	lbs.	lbs.
Ash,	17,000	...	9,300
Beech,	11,500 to 17,300	...	9,300
Elm,	14,000	...	10,300
Fir (Red Pine), . . .	12,000	540 to 840	6,800
Oak, English, . . .	12,000	2,316	6,400
„ American, . . .	10,000	...	6,000

29. **Strength of Timber.**—The tenacity of timber is much greater when pulled in the *direction* of the grain than *across* the

grain. In the former case, the tenacity varies with that of the fibres themselves, while in the latter case, it depends on the lateral adhesion of the fibres. Table VI gives the strength when the timber is dry and in good condition. It will be noticed that the tensile strength with the grain is much greater than the crushing strength.

(6.) CAST IRON.

30. Uses of Cast Iron in Structures.—Cast iron is a material which enters largely into most classes of structural work, although of recent years its use has not been so general as formerly. At present, wrought iron and steel are gradually taking its place in those members of a structure which are exposed to direct tension, or to bending stresses. One reason of this is, that the tensile strength of cast iron is small compared with that of wrought iron or steel; but another, and perhaps more important, cause is that it is not a reliable metal. In the process of casting cavities are often formed in the body of the casting, owing to the generation of gases. Also, owing to the shape of the casting, or the presence of iron of different qualities, unequal stresses are generated in the process of cooling, which sometimes cause the fracture of the casting; while in other cases initial stresses are developed, causing minute cracks which escape detection, but which afterwards may cause failure. Cast iron, unlike wrought iron and other materials, gives no warning of its approaching failure, which is also a very great objection. Notwithstanding all these drawbacks, however, it will, probably, always be useful and economical in those parts of a structure which are exposed to direct compressive stresses unaccompanied by vibration; as in pillars for supporting warehouses, mills, &c. It is also well adapted for arched ribs, for girders, roofs, &c.; although even here, except in the case of small spans, wrought iron or steel will be found more economical. It is much used by the general builder for gutters, lintels, window-frames, &c., for which purposes it is well suited. It also lends itself more easily than wrought iron or steel for ornamental work, and is much used for the parapets of bridges and such other positions where appearance is of importance, but where it is not exposed to much stress.

31. Varieties of Cast Iron.—There are various kinds of cast iron which have their distinctive names, according to the district in which they are made, or the kind of ore from which they are

manufactured, and they differ a good deal from each other both in colour and texture. Their strengths are very much influenced by the presence of foreign materials, such as carbon, phosphorus, sulphur, &c.

According to Hodgkinson, "white cast iron is less liable to be destroyed by rusting than the gray kind; and it is also less soluble in acids; therefore it may be usefully employed where hardness is necessary, and where its brittleness is not a defect; but it should not be chosen for purposes where strength is necessary. In a recent fracture it has a white and radiated appearance, indicating a crystalline structure. It is very hard and brittle."

"Gray cast iron has a granulated fracture, of a gray colour, with some metallic lustre; it is much softer and tougher than white cast iron."

Between these extremes of colour there are many intermediate varieties, the whiter kinds, as a rule, being the harder and more brittle, while those approaching to gray are the softer and tougher, and the better fitted for structural work.

The castings which give the best results, both as regards their ultimate strength and their elasticity, are produced by mixing in proper proportions a number of different kinds of the metal, the best combinations being the result of practical experience.

The tenacity of cast iron varies a good deal; inferior qualities have only a strength of about 5 tons to the square inch, while in some cases as high a result as 15 tons has been obtained. The average tenacity is from 7 to 8 tons.

32. Relative Strengths of Small and Large Castings.—The transverse strength of small castings is relatively greater than that of large ones, and is augmented by rapid cooling.

What is termed the skin of a bar, or the outside chilled surface, appears to add to its *transverse* strength.

This is borne out by the results of some experiments made by Major Wade, and given in Table VII., where he compared the transverse and tensile strengths of proof bars cut from the body of a cast-iron gun with those cast at the same time in separate vertical dry sand moulds.

These experiments show that in small castings the transverse strength is increased by rapid cooling, but the tensile strength is diminished. This diminution of tensile strength, however, does not seem to be common, and only applies to high class castings similar to those employed in these experiments. Major Wade remarks that, "As a general rule, the tenacity of the common sorts of foundry iron is increased by rapid cooling."

TABLE VII

COEFFICIENT OF TRANSVERSE RUPTURE.		TENSILE STRENGTH PER SQUARE INCH.		SPECIFIC GRAVITY.	
Bar cut from gun.	Bar cast separate.	Bar cut from gun.	Bar cast separate.	Bar cut from gun.	Bar cast separate.
lbs.	lbs.	lbs.	lbs.		
8,415	9,880	30,234	29,143	7.196	7.263
9,233	9,977	31,087	30,039	7.278	7.248
8,575	10,176	26,367	24,583	7.276	7.331
8,741	10,011	29,229	27,922	7.250	7.281
					} Mean.

The chilled surface or skin of a casting adds very much to its power of resisting a crushing stress. Mr. Hodgkinson (in his experiments on the crushing strength of cast-iron pillars) found that the external part of the casting was always harder, and consequently stronger to resist crushing, than that near to the centre; and in the case of hollow pillars the hardness increased with the thinness of the tube. He found that, "In solid pillars, $2\frac{1}{2}$ inches diameter of Low Moor iron No. 2, the crushing force per square inch of the central part was 29.65 tons, and that of the intermediate part near to the surface was 34.59 tons; whilst the external ring, $\frac{1}{2}$ inch thick, of a hollow cylinder, 4 inches diameter, of which the outer crust had been removed, was crushed with 39.06 tons per square inch; and external rings of the same iron, thinner than half-an-inch, required from 49.2 to 51.78 tons per square inch to crush them. These facts show the great superiority of hollow pillars over solid ones of the same weight and length."

In the case of large castings the difference of hardness and crushing strength between the iron at the centre and at the surface, although it exists, is not nearly so great as in small castings.

33. Engineers' Requirements in Castings for Structural Work.—In engineers' specifications, when referring to castings, it is

usually laid down that they must be free from any defects and be cast with sharp edges. In the case of pillars, it is becoming usual to specify that they be cast vertically on their ends and not on their sides; it is also usual to specify that at each melting

TABLE VIII.—TENSILE AND TRANSVERSE STRENGTH OF CAST IRON.

DESCRIPTION OF IRON.	Tensile Strength per Square Inch of Section.		Transverse Strength, 4' 6" Bearing.
	lbs.	Tons.	lbs.
Carron Iron (Scotland), No. 2, Cold Blast, }	16,683	= 7.45	476
Carron Iron (Scotland), No. 2, Hot Blast, }	13,505	= 6.03	463
Carron Iron (Scotland), No. 3, Cold Blast, }	14,200	= 6.35	446
Carron Iron (Scotland), No. 3, Hot Blast, }	17,755	= 7.93	527
Devon Iron (Scotland), No. 3, Hot Blast, }	21,907	= 9.78	537
Buffery Iron (Birmingham), No. 1, Cold Blast, }	17,466	= 7.80	463
Buffery Iron (Birmingham), No. 1, Hot Blast, }	13,434	= 6.00	436
Cold Talon Iron (N. Wales), No. 2, Cold Blast, }	18,855	= 8.42	413
Cold Talon Iron (N. Wales), No. 2, Hot Blast, }	16,676	= 7.45	416
Low Moor Iron (Yorkshire), No. 3, Cold Blast, }	14,535	= 6.49	467
Mean,	16,502	= 7.37	464

one or more test-bars of certain dimensions are to be cast, which are afterwards to be placed on supports a certain distance apart and tested with dead weights in the centre. For example, rect-

angular bars, 2 inches by 1 inch, placed on supports 3 feet apart with the deep side vertical, should bear a central load of 30 cwts. and deflect before fracture at least .29 inch. Another common test is, that bars, 1 inch square, placed on supports 4 feet 6 inches apart, shall bear a central load of 530 lbs. It is not usual to specify the direct tensile or crushing stresses of the bar, though it is sometimes done.

Table VIII. gives the results of some experiments made by Mr. Hodgkinson on cast-iron bars, 1 inch square, the tensile strength was obtained by a direct pull, and the transverse strength by placing each bar on two supports 4 feet 6 inches apart, and loading it at the centre with gradually increasing static loads.

In America, iron masters obtain castings of much greater strength than we do in this country. These are used for the manufacture of guns. This great strength is got by employing a very superior ore to begin with, and then by frequent recasting and keeping the metal under fusion from three to four hours. By these latter means an increase of strength equal to 60 per cent. may be obtained.

(c.) WROUGHT IRON.

34. Wrought Iron as used in Structures.—Of all the materials which are at the present time employed in engineering structural works, wrought iron is the most general. Whether or not this will continue to be so, it is difficult to say. Appearances at present seem to indicate that steel in some form or other will gradually replace it, mainly for economical reasons.

The quality of wrought iron varies a good deal, and depends primarily on the quality of the cast iron from which it is made, and on the care taken in its manufacture. The amount of carbon which it contains has a great deal to do with its quality. In very soft irons the quantity of carbon is almost imperceptible; when it reaches $\frac{1}{4}$ per cent., the iron becomes harder and stronger, and is known as "soft steel." The presence of carbon, although it increases its strength, makes the welding much more difficult.

35. Testing Wrought Iron.—When a bar of uniform section is tested for tensile strength, the extension which occurs is at first pretty general over the length of the bar. When the bar, however, approaches the point of rupture, a large local extension takes place near the place of fracture, attended

by a corresponding contraction of the area of the bar at this point.

After rupture, the contraction of area at the point of fracture should be noted. This is a very important index of the quality of the iron. The extension which the bar undergoes in a certain length should also be observed. The quality of the iron is ascertained from the following results:—

- (1) The ultimate tensile strength per square inch.
- (2) The contraction of area at the point of fracture, or the extension in a certain length of the specimen.

36. Tensile Strength of Wrought Iron.—The ultimate strength of a specimen of wrought iron depends to a certain extent on the shape of the specimen. In order to get good results, there should be no sudden variations of section in the bar tested, and care should be taken to have the pull exactly longitudinal with the bar.

Table IX. gives the net results of 587 experiments made by Mr. Kirkaldy.

TABLE IX.—TENSILE STRENGTH OF WROUGHT IRON.

NUMBER OF EXPERIMENTS.	BREAKING WEIGHT PER SQUARE INCH OF ORIGINAL AREA.		
	Highest.	Lowest.	Mean.
	Tons.	Tons.	Tons.
188 Rolled bars,	30·7	19·9	25·7
72 Angles and straps, . .	28·5	16·9	24·4
167 Plates with the grain, .	27·9	16·7	22·6
160 ,, across the grain, .	27·1	14·5	20·6

It will be seen from the table that iron of very different qualities was tested. On the whole, the quality is much superior to that ordinarily used for structural work.

Table X. may be taken as representing the tensile strength both *with* and *across* the grain, and also the contraction of area at the point of fracture of iron as ordinarily used for constructional work.

TABLE X.—STRENGTH OF WROUGHT IRON AS USED IN BRIDGE WORK, &c.

DENOMINATION.	Tensile strength with the grain.	Tensile strength across the grain.	Contraction of area at point of fracture with the grain.	Contraction of area at point of fracture across the grain.
	Tons.	Tons.	Per cent.	Per cent.
Plates,	20 to 22	16 to 18	7 to 10	3 to 4
Angles and Tees, . . .	21 to 23	...	12 to 16	...
Flat bars,	21 to 24	...	18 to 22	...
Round bars up to 1½ in. diam.,	20 to 22	...	16 to 18	...
Round bars above 1½ ,,	19 to 21	...	13 to 16	...

Soft and ductile irons draw out a good deal under stress, and though they may not give a high breaking stress per square inch of the original section of the bar, yet, when measured with respect to the fractured area, they show very good results.

A hard specimen, which possesses little ductility, does not give a great elongation, and the fractured area will not be much less than the original area of the bar. One advantage of using a soft iron in a structure is, that it will stretch a good deal before fracture takes place, and consequently will give ample warning before it collapses.

As a rule, the smaller and thinner a plate or bar is after leaving the rolls, the better results it will give in testing. This seems natural enough when we consider that the particles of iron are more likely to be thoroughly welded together, and that impurities are more likely to be eliminated. Angles and tees also give better results than plates rolled from the same quality of iron.

37. Tensile Strength of Wrought Iron across the Fibre.—In the process of rolling plates and bars the molecules of the iron are elongated in the direction in which the plate or bar is rolled, what is termed a "fibre" being formed, and the bar always shows greater strength when tested in the direction of the fibre than when tested across it, the proportion roughly varying as 21 to 18. The elongation of the specimen, and the contraction of area at the point of rupture, are also greater when the specimen is tested with the grain than when tested across it. It is usual for engineers, when drawing up a rigid specification of the

strength of plates, to take cognisance of this fact, and to mention the ultimate strength and contraction of area for plates when tested both ways.

38. **Strength of Welds.**—There is a popular belief that the strength of a welded joint is as great as that of the bar itself, and no doubt this is so, when the iron is of a quality well adapted for welding, and when the greatest care is taken by using a clean fire, scarfed joints, &c. Experience, however, proves that the strength of the weld is nearly always less than that of the original bar, in some cases to the extent of 50 per cent. For this reason, and also on account of the cost, welds should, if possible, be avoided in structural work, and if they have to be made, the bar should be swelled out, so that its sectional area be greater at the welded joint than at other parts. By this means the deterioration of strength suffered by the welding process is partially or wholly neutralised.

39. **Iron Wire.**—When wrought iron is drawn out in the form of wire, its tensile strength is very much increased; the amount of increase depending upon the diameter. For example, iron wire, $\frac{1}{10}$ th inch in diameter, when made from iron of a tensile strength of 25 tons per square inch, will have an ultimate strength of about 35 tons, or even more. The wire used in the cables of the Niagara bridge had a strength of about 44 tons per square inch, and cases have been known where it has reached 56 tons. It is a strange thing that the specific gravity of wire is rather less than that of the iron from which it was produced, so that its additional strength is not due to the closeness of the molecules, but must arise from some other cause not clearly understood. When wire is annealed, it loses a large portion of its strength, and becomes, in fact, only about the same as the iron from which it was produced.

40. **Compressive Strength of Wrought Iron.**—It is very rarely that structures fail from the actual crushing of the material. If a compressive member fail, it is generally due to buckling or bending sideways, owing to want of proper stiffening. From experiments made on short cylinders, it has been ascertained that ordinary wrought iron is crushed or bulged with from 16 to 20 tons per square inch.

41. **Effects of Annealing.**—Annealing wrought iron of small sections diminishes its ultimate tensile strength but increases its ductility. In the case of iron which has suffered fatigue, annealing is very beneficial. It is a good practice to anneal crane chains from time to time; by this means their brittleness is removed and their ductility restored. According to Morin,

the annealing of large forgings is injurious, as it produces a crystalline structure; and the same authority states that the prolonged annealing of iron of small sections has a bad effect.

42. **Shearing Strength of Wrought Iron.**—The shearing strength of wrought iron is practically equal to its tensile strength; this may be tested by punching holes in plates, or by cutting them with an ordinary shearing machine.

Table XI. gives the result of some experiments made by Mr. Little in order to determine the force required to shear wrought-iron bars with parallel shear blades.

TABLE XI.—EXPERIMENTS ON SHEARING WROUGHT-IRON BARS WITH PARALLEL CUTTERS.

No. of Experiment.	Width of Bar in inches.	Thickness of Bar in inches.	Sectional Area Square inches.	PRESSURE ON CUTTERS.	
				Total Pressure in Tons.	Pressure per Square Inch of Area cut, Tons.
1	3·0	0·5	1·50	33·4	22·3
2	3·0	0·5	1·50	34·6	23·1
3	3·0	1·0	3·00	69·2	23·1
4	3·0	1·0	3·00	68·1	22·7
5	3·02	1·0	3·02	59·7	19·8
6	3·02	1·0	3·02	62·1	20·6
7	5·0	2·04	10·20	210·6	20·6

43. **Expansion and Contraction due to Change of Temperature.**—

All metals in the solid state expand with an increase, and contract with a diminution of temperature, and the change of length which they undergo is proportional to the change of temperature, at least between the limits of 32° and 212° Fah., or between 0° and 100° on the centigrade scale.

The *coefficient of linear expansion* of a material is the fractional part of its length by which it elongates or shortens owing to a change of temperature of 1°.

Most tables give the coefficient for 1° on the centigrade scale. It will be an easy matter, however, to reduce the results to the Fahrenheit scale, bearing in mind that 1° Fah. : 1° cent. :: 5 : 9.

Let l = length of a bar at 0° C.

l_1 = its length at t° .

α = the coefficient of linear expansion for 1° C.

Then the elongation for $t^{\circ} = \alpha t l$

$$\text{and } l_1 = l(1 + \alpha t) . . . (1).$$

Example 1.—By how much will a wrought-iron girder, 200 feet in length, elongate when the temperature is raised 40 degrees Fah.?

The amount of elongation is expressed by $\alpha t^{\circ} l$ where

$$\alpha = 0.00000642.$$

$$t = 40^{\circ}.$$

$$l = 200 \text{ feet.}$$

$$\text{Elongation} = 0.0000642 \times 40 \times 200 = 0.5136 \text{ foot} = 0.61632 \text{ inch.}$$

TABLE XII.—COEFFICIENTS OF LINEAR EXPANSION.

Description of material.	Coefficient of linear expansion for 1° C.	Coefficient of linear expansion for 1° Fah.	Authority.
METALS.			
Brass rods,	00001052	Ray.
Copper,	00000944	Smeaton.
Iron (cast),	000011094	...	Ramsden.
„ „ (from bar 2 in. square),	000011467	...	Adie.
„ „ (from bar $\frac{1}{4}$ in. square),	000011022	...	„
„ (wrought),	000012204	...	Laplace & Lavoisier.
„ „	00000642	Borda.
Steel (untempered),	000010788	...	Laplace & Lavoisier.
„ (tempered),	000012396	...	„
„ (blistered),	000011500	...	Smeaton.
„ (rod),	000011447	...	Ramsden.

(d.) STEEL.

44. Different Kinds of Steel.—The term steel is a very elastic one, and includes metals which differ very widely from each other in strength and other properties. Of late years a mild form of steel has been largely manufactured for boilers, ships, bridges, &c., which differs very little from wrought iron; in fact, it is very difficult to say where “wrought iron” ends and “steel” begins.

In its chemical composition steel is the same as wrought iron with a little admixture of carbon. A very slight difference in the amount of carbon produces a very great difference in the strength of the metal; thus, a steel which has a tensile strength of 28 tons per square inch may, by slightly altering its chemical composition, have its strength raised to 50 or 60 tons.

It is principally with mild steel that we are here concerned.

Formerly, the difficulties attending the manufacture of a reliable metal were so great, that engineers set their faces against its use. Many failures have occurred which could not be accounted for, and justified the suspicion with which this metal was regarded. This uncertainty in the manufacture and behaviour of steel has recently passed away, and a material can now be produced which is quite as reliable as wrought iron, and even more uniform in its strength; and there can be little doubt that in the future it will to a large extent take the place which wrought iron now holds as a material for structures.

The advantages which it offers, when applied to bridge-work, are very great and very obvious.

Its strength is from 40 to 50 per cent. in excess of that of wrought iron, and it has a proportionate superiority in elasticity and ductility, while the cost of its production is not very much greater. The advantages which this superior strength gives are great, especially in bridges of large span, as the dead load of the structure will be very much diminished. Other advantages will be subsequently referred to when treating on steel bridges.

45. Strength of Steel.—The *tensile strength* of steel varies between very wide limits. That for mild steel, as used in structural work, is from 27 to 32 tons per square inch; while, in very hard varieties, it may be as high as 60 tons.

The *crushing strength* for the soft varieties is about equal to the tensile strength. In the harder varieties it is much greater, and may reach as much as 150 tons.

The *shearing strength* is approximately equal to three-fourths of the tensile strength. It has been found that mild steel of 29 tons tensile strength has only a shearing strength of $24\frac{1}{2}$ tons. On account of this weakness in the shearing strength, it is the practice to use iron rivets for steel structures.

46. Elasticity of Steel.—From experiments made by the "Steel Committee," it appears that the limit of elastic reaction for the qualities of steel upon which they experimented was, on the average, about 21 tons per square inch both for tension and compression. For milder qualities, it is not so high. For 28-ton steel the limit of elasticity is reached at about 18 tons.

From the experiments above referred to, it was found that with bars under compression, the mean decrement of length per ton per square inch was $\frac{1}{13,459}$ th of the original length of the bars; and under tension, the mean increment of length was $\frac{1}{13,089}$ th of the original length. This is equivalent to a modulus of compressive elasticity = 13,459 tons, and a modulus of tensile elasticity = 13,089 tons, or a mean of 13,274 tons.

From experiments made by Sir W. Fairbairn, he found the modulus of elasticity somewhat higher—namely, 13,839 tons. The average modulus may be taken as 13,393 tons, or 30,000,000 lbs., which is considerably in excess of that for wrought iron.

47. Admiralty Tests for Steel.—The Admiralty specification for steel plates, angles, &c., is as follows:—

"1. Strips cut lengthwise of the plates to have an ultimate tensile strength of not less than 26, and not exceeding 30 tons per square inch of section, with an elongation of 20 per cent. in a length of 8 inches.

"2. Strips cut lengthwise or crosswise, $1\frac{1}{2}$ inch wide, heated uniformly to a low cherry-red, and cooled in water of 82° Fah., must stand bending in a press to a curve of which the inner radius is one and a half times the thickness of the plates tested.

"3. The strips are to be cut in a planing machine, and are to have the sharp edges taken off.

"4. The ductility of every plate is to be ascertained by the application of one or both of these tests to the shearing, or by bending them cold by the hammer on the Contractor's premises and at his expense.

"5. All plates to be free from lamination and injurious surface defects.

"6. One plate to be taken for testing by tensile, extension, and tempering tests from every invoice, provided the number of plates does not exceed 50. If above that number, one for every

addition of 50, or portion of 50. Plates may be received or rejected without a trial of every thickness on the invoice.

"7. The pieces of plate cut out for testings are to be of parallel width from end to end; or for at least 8 inches of length.

"When the plates are ordered by thickness, their weight is to be estimated at the rate of 40 lbs. per square foot for plates of 1-inch thick, and in proportion for plates of all other thicknesses; the weight so produced is not to be exceeded, but a latitude of 5 per cent. below this will be allowed for rolling in plates of half an inch in thickness and upwards, and 10 per cent. in thinner plates.

"These weights may be ascertained by weighing as much as 10 tons at a time.

"The steel for angles, tees, bars, &c., to stand a tensile strain of 26 tons to the square inch, and not to exceed 30 tons to the square inch."

The other tests for angles, &c., to be the same as those described for plates.

48. **Lloyd's Tests for Steel.**—Lloyd's rules for steel used in ship-building stipulate that steel plates and angle and bulb steel shall have an ultimate tensile strength of not less than 27 tons, and not exceeding 31 tons per square inch, with an elongation before fracture equal to 20 per cent., measured on a length of 8 inches. They also specify that "strips cut from the plate, angle, or bulb steel to be heated to a low cherry-red, and cooled in water of 82° Fah., must stand bending double round a curve, of which the diameter is not more than three times the thickness of the plates tested." The Liverpool Underwriters' Registry give a tensile range of strength from 28 to 32 tons per square inch.

49. **Rules of the French Admiralty.**—The rules of the French Admiralty for the strength of steel plates, &c., are somewhat different from those already given. They do not prescribe any maximum strength, and the minimum strength is fixed according to the thickness of the plates. For example, for plates $\frac{3}{4}$ inch in thickness, the minimum strength is fixed at about 28 tons per square inch, and for thinner plates it is fixed at about 28 $\frac{1}{2}$ tons. In order to test the ductility they prescribe that, in an 8-inch test-piece, the elongation must be 20 per cent. of its original length, and provided this test is complied with they do not fix any maximum strength.

50. **Steel Castings.**—Great improvements have been made during the last few years in the production of steel castings, and they can also be made at prices very much lower than formerly.

The chief objection to castings made in steel used to be their want of ductility; now they can be made of soft steel of a tensile strength of about 30 tons, and giving an elongation of 20 per cent. in an 8-inch test-piece.

If the steel casting is to be used in a position where it will be subjected to vibratory stresses, it is advisable to anneal it. Up to the present, steel castings have not been much used by the bridge-builder, but in the future it is probable that they will become more common.

51. Effects of Annealing on Steel.—Annealing steel reduces its strength but increases its ductility. It is very useful when applied to castings.

Table XIII., which gives the results of some experiments, shows the effect of annealing on plates.

TABLE XIII.

KIND OF STEEL	UN-ANNEALED.		ANNEALED.	
	Tensile strength per sq. inch.	Ultimate set in length of 8 inches.	Tensile strength per sq. inch.	Ultimate set in length of 8 inches.
	Tons.	Per cent.	Tons.	Per cent.
Hard steel $\frac{1}{4}$ -in. plate, .	32·97	16·65	28·52	24·12
Mild „ $\frac{1}{4}$ „ .	26·60	24·32	24·05	29·87
„ „ $\frac{1}{4}$ „ .	28·55	25·05	26·95	26·90

52. Treatment of Steel by Hydraulic Pressure.—The late Sir Joseph Whitworth introduced and patented a system, which promises to become common, of subjecting steel ingots, when in the fluid state, to great pressure. The pressure is produced by hydraulic power, and may reach as much as 12 tons per square inch on the metal. When the fluid metal is poured into the mould, the pressure is applied, and may be continued from 1 to 4 hours. Its effect is to drive out all gases and other impurities which may be collected in the body of the metal, and to render it more ductile and homogeneous in its texture. By the old method of casting, a large portion of the ingot con-

tained cavities which necessitated a good deal of cutting to waste. The contraction produced in the length of the ingot during the application of the pressure amounts to as much as 12½ per cent.

Tables XIV. and XV.* give results of the tests of the pressed and unpressed ingots.

TABLE XIV.—MEAN OF TEST-PIECES CUT LONGITUDINALLY.

	Elastic limit in tons per square inch.	Ultimate breaking stress in tons per square inch.	Contraction in area at point of fracture	Elongation in 4 inches.
			Per cent.	Per cent.
Unpressed Ingot,	11·11	29·18	4·41	8·76
Pressed Ingot, .	11·45	29·53	7·90	12·51

TABLE X.—MEAN OF TEST-PIECES CUT TRANSVERSELY.

	Elastic limit in tons per square inch.	Ultimate breaking stress in tons per square inch.	Contraction in area at point of fracture.	Elongation in 4 inches.
			Per cent.	Per cent.
Unpressed Ingot,	11·43	28·04	3·61	7·91
Pressed Ingot, .	12·38	30·07	7·57	12·74

CHAPTER IV.

MECHANICAL LAWS RELATING TO STRESSES ON STRUCTURES.

DIAGRAMS OF FORCES.

53. Preliminary.—The whole subject of the investigation of the stresses on beams and framed structures is a very important one,

* Greenwood.—*Proc. Inst. of C.E.*, vol. xcviij., p. 83.

and of late years a number of eminent men have devoted a great deal of time and skill to its elucidation.

Our knowledge of the subject now is very much more complete than formerly, and, generally speaking, the subject is much simplified, and the results arrived at in most cases are practically exact.

It is true that on some questions (as, for example, the stresses on continuous girders, and the investigation into the strengths and the distribution of stresses in solid beams), something yet remains to be explained and simplified; yet these cases are the exceptions to the general rule stated, and the difficulties and ambiguities which arise in the investigation of these special cases need not prevent the student from thoroughly understanding the subject in general.

It may here be stated that it is presumed the student possesses an elementary knowledge of mathematics; with this knowledge he will have little difficulty in understanding the solutions given of the different problems which will be presented to him.

The two main mechanical principles upon which are based the calculation of stresses in structures are:—

- (1) The principle of moments;
- (2) The parallelogram or polygon of forces.

These two principles we shall briefly explain and illustrate.

54. Mechanical Forces.—A force is a quantity which is measured by some unit of weight, such as pounds, cwts., or tons.

A straight line may be taken to represent a force—(1) when its length measured to some scale, represents the magnitude of the force in lbs., tons, &c.; and (2) when its direction corresponds to the line of action or the direction of the force.

We may say that a force is completely determined when we know—

- (1) Its magnitude,
- (2) Its point of application,
- (3) Its direction.

Suppose a body, A B, whose weight is W (fig. 6), to rest on a horizontal surface, A C; it presses on the surface with a force equal to W ; the line of action of this force is vertical, and it passes through the centre of gravity of the body. At the same time the surface, A C, is said to exert an upward vertical pressure against the body equal to W . This upward pressure is termed *the vertical reaction of the surface, or the supporting force.*

55. Forces of Compression and Tension.—If two equal forces, P, P , act on a body, $a b$ (fig. 7), in a direction *towards* each other and in the same line, the body is in a state of *compression*, and is said to receive a *thrust*; the amount of this compressive force being equal to P .

Members of a structure which are wholly in compression are sometimes called *struts, columns, or pillars*.

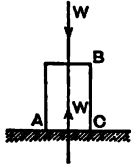

Fig. 6.

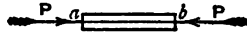

Fig. 7.

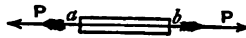

Fig. 8.

If the two equal forces, P, P , act on $a b$ *away* from each other and in the same line (see fig. 8), the body is in a state of *tension*, and is said to receive a *pull*; the amount of the tensile force being equal to P .

Members of a structure which are wholly in tension are sometimes called *ties*.

56. Principle of Moments.—*The moment of a force with respect to a fixed point is the product of its intensity into the perpendicular distance between the point and the direction of the force.*

The force may be expressed in pounds, tons, or any other unit of weight. The perpendicular distance may be expressed in inches, feet, or any other unit of measure.

If the force and distance be expressed in pounds and inches respectively, the moment will be expressed in *inch-pounds*. If they be expressed in tons and feet respectively, the moment will be expressed in *foot-tons*, and so on.

In fig. 9, the body $A a$ is supposed to be acted upon by a force P , in the direction of the line $a P$. A is a fixed point or pivot round which the body may revolve. Draw $A a$ perpendicular to $a P$; then the moment of the force P with respect to the point A is equal to $P \times A a$; and the tendency of the force is to cause the body to revolve round A in a direction opposite to that of the hands of a clock.

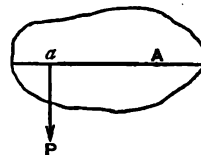

Fig. 9.

The principle of moments may be thus stated—

44 MECHANICAL LAWS RELATING TO STRESSES ON STRUCTURES.

If any number of forces acting in the same plane on a body, keep it in equilibrium, or in a state of rest, then the sum of the moments of the forces which tend to turn the body in one direction round a fixed point, must be equal to the sum of the moments of the forces which tend to turn it in the opposite direction round the same point.

In order to explain this by the aid of a diagram, let A B

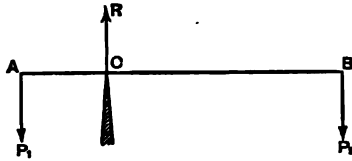

Fig. 10.

(fig. 10) represent a horizontal rod or beam resting on a fixed support or fulcrum, C, and let weights P_1 and P_2 be suspended from its extremities. The weight P_2 has a tendency to turn the rod round C in the direction of the hands of a clock, while the weight P_1 has a tendency to turn it in the opposite direction. If the bar be in equilibrium the moment of P_1 with respect to C must be equal to that of P_2 with respect to the same point; or expressing the relationship by symbols,

$$P_1 \times A C = P_2 \times B C \quad . \quad . \quad . \quad (1)$$

This is also called the *principle of the lever*.

Another condition of equilibrium comes into operation here, namely, the upward reaction at C, or the supporting force is equal to the sum of the downward forces.

If R = supporting force, we have (in symbols)

$$R = P_1 + P_2 \quad . \quad . \quad . \quad (2)$$

This principle may be thus stated—

If a loaded beam be supported by one or more props, the sum of the upward reactions of these props is equal to the total weight on the beam.

It is not necessary that the external forces should be parallel, or act in a vertical direction, in order that the principle of moments should hold true. In fig. 11, the two forces, P_1 and P_2 , are shown acting in directions which are inclined to each other; let their directions be produced so as to meet at the point O.

Let x_1 and x_2 represent the lengths of the perpendiculars from the point C on these directions. If the beam be in a state of rest, we have, as before,

$$P_1 \cdot x_1 = P_2 \cdot x_2$$

Join OC, the reaction at C acts along this line. To find its amount, set off $Oa = P_1$ and $Ob = P_2$; draw ac and bc

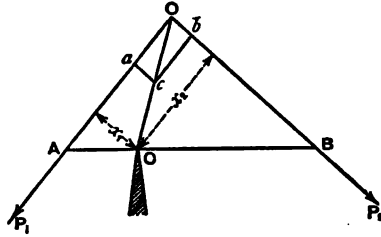

Fig. 11.

parallel to OB and OA respectively; these lines will meet OC at the same point, c; and the line Oc will represent the magnitude of the reaction at C.

57. **Graphic Method of determining the Stresses on Framed Structures.**—The simplest, and in many cases the most accurate, method for determining the stresses on framed structures is by means of stress-diagrams, which must be accurately drawn to scale. In such diagrams lines are made to represent forces, both in magnitude and direction. By measuring these lines to the proper scale, the stress on any member (no matter how complicated the structure is) may be determined. It is assumed that the different members of the structure are so connected together by pins that the joints are as free to rotate as if they were hinged; when this is so, the stress-diagram is theoretically a perfect representation of the stresses on the structure. In practice, however, this is not generally the case, as the connections have a certain amount of rigidity, which, to a certain extent, modifies the stresses.

58. **Equilibrium of Three Forces acting on a Point-Parallelogram of Forces.**—A point acted upon by forces is said to be in equilibrium when it is in a state of rest. This occurs when the forces balance each other.

A point acted upon by a *single* force cannot be in equilibrium, as it will move in the direction in which the force acts, and will continue to do so as long as the force is applied.

If a point acted upon by *two* forces be in equilibrium, the two following conditions must be fulfilled :—

1. The forces must be equal to each other in magnitude.
2. They must act in the same straight line, but in *opposite* directions.

If three forces acting in the same plane on a point, as represented by three straight lines, be in equilibrium, the following condition must be fulfilled :—

If a parallelogram be drawn which has for its adjacent sides two straight lines representing in magnitude and direction any two of the forces, then the third force must be equal in magnitude, and act in an opposite direction to the diagonal of the parallelogram, drawn from the junction of the before-mentioned adjacent sides.

In order to illustrate this, in fig. 12, let three forces, represented by the three straight lines, $O A$, $O B$, $O C$, act on the point O in a direction *away* from it (as shown by the arrow-heads). Take any point, O_1 (fig. 13), and draw $O_1 A_1$, $O_1 C_1$, equal and parallel to

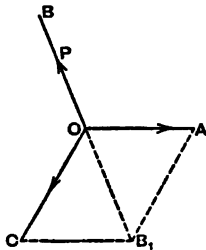

Fig. 12.

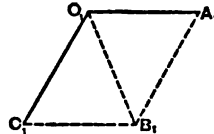

Fig. 13.

$O A$, $O C$ respectively. Complete the parallelogram $O_1 A_1 B_1 C_1$, and draw the diagonal $O_1 B_1$. Now, if the forces $O A$, $O B$, $O C$ (fig. 12) balance each other, $O B$ must be equal and parallel to $O_1 B_1$ (fig. 13). The diagonal $O B_1$ of the parallelogram $A O C B_1$ is called the *resultant* of the two forces $O A$ and $O C$; and it produces the same effect on the point O as these two acting together.

Example 1.—If two forces of 3 and 4 tons act on a point in directions at right angles to each other and away from the point, what is the magnitude and direction of their resultant force?

In fig. 14, draw a line $O A = 3$ tons, on any scale; draw $O B$ perpendicular to $O A$, and make $O B = 4$ tons on the same scale; complete the parallelogram $A O B C$ and join $O C$. $O C$ will re-

present the resultant of OA and OB ; by scaling we find it = 5 tons. If OC be produced on the other side of O to C_1 , making $OC_1 = OC$, then OC_1 will balance OA and OB .

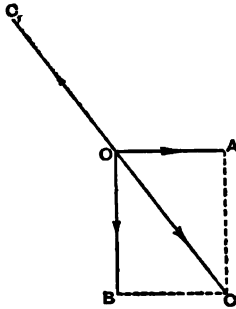

Fig. 14.

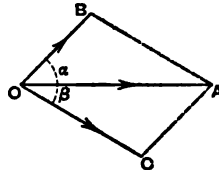

Fig. 15.

59. Resolution of Forces.—We have seen how the resultant of two forces, or what may be termed *the composition of forces*, may be found. The converse of this, called *the resolution of forces*, consists in resolving a single force into two others, acting in any direction.

If, for example, we have a single force, OA (fig. 15), and we wish to resolve it into two others making angles α and β with its direction, draw lines OB and OC , making angles α and β respectively with OA ; through A , draw AB parallel to OC , and AC parallel to OB ; then OB and OC will represent the required forces both in magnitude and direction.

60. Triangle of Forces.—What is known as *the principle of the triangle of forces* is merely another way of stating that of the parallelogram of forces.

The principle may be stated thus—

If three forces acting at the same point are in equilibrium, three lines drawn parallel to them will form a triangle, the lengths of the sides of which are proportional to the forces. In fig. 12 we have the three forces OA , OB , OC in equilibrium and acting at the point O ; take a line O_1A_1 (fig. 13), parallel to OA ; through its extremities, O_1 and A_1 , draw O_1B_1 , A_1B_1 parallel respectively to OB and OC , and meeting at the point B_1 . The sides of the triangle $A_1O_1B_1$ are proportional to the forces OA , OB , and OC ,—namely, $O_1A_1 : O_1B_1 : A_1B_1 = OA : OB : OC$; and if O_1A_1 is made equal to OA , then O_1B_1 and A_1B_1 will be equal to OB and OC respectively.

It will be gathered from the foregoing, that if there are three forces meeting at a point, which are in equilibrium; if their directions be known; and, further, if the magnitude of one of them be known, then the values of the other two can be found. In order to illustrate this, suppose the two ends, a and b (fig. 16), of a string, aob , to be fixed, and a weight, W , to be hung from the point, o , it is required to determine the tensions

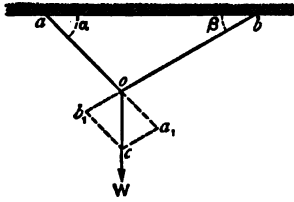

Fig. 16.

on the portions oa and ob of the string. We have here three forces acting at the point, o , which are in equilibrium—namely, the weight, W , which acts vertically downwards, and the tensions on oa and ob . Of these three forces only one—viz., W —is known. In order to find the other two we proceed as follows:—

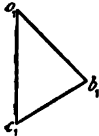

Fig. 17.

On the vertical line through o measure off a distance, oc , on any scale, equal to W . Through c , draw ca_1 , cb_1 parallel respectively to ob and oa and meeting these lines produced in b_1 and a_1 . Then the lines, oa_1 and ob_1 , which are the sides of the parallelogram, oa_1cb_1 , will represent the tensions on oa and ob respectively; and their amounts may be determined by measuring their lengths on the scale.

It will be generally found more convenient, especially in complex structures, to have a separate diagram showing the stresses on the different members of the structure, apart from the figure representing it. Thus, in the case we have been considering, take a vertical line, o_1c_1 (fig. 17), to represent the weight, W ; through its extremities o_1 and c_1 draw o_1b_1 and c_1b_1 parallel respectively to oa and ob , and meeting at the point, b_1 ; these lines will represent the stresses on the strings oa and ob . The diagram in fig. 17 is called the *stress-diagram*.

The above is the graphic method of finding the stresses on the string.

Analytical Method.—The stresses may be found analytically thus:—If oa , ob make angles α and β respectively with ab , we have the following equations:—

$$\text{Stress on } oa = W \sin \alpha \cdot \frac{W \cos \beta + \sin(\alpha + \beta)}{W \cos \alpha + \sin(\alpha + \beta)}$$

$$\text{Stress on } ob = W \sin \beta \cdot \frac{W \cos \alpha + \sin(\alpha + \beta)}{W \cos \alpha + \sin(\alpha + \beta)}$$

Suppose for example that $W = 100$ lbs.; and $\alpha = \beta = 45^\circ$, then stress on $oa =$ stress on $ob = 100 \sin. 45^\circ = \frac{100}{\sqrt{2}} = 70.7$ lbs.

Example 2.—In fig. 18, a weight of 5 tons is shown suspended from the extremity, *o*, of an inclined prop, *ob*, the other extremity of which rests against a wall. A horizontal tie, *oa*, is fastened to *o*, and the other end fixed to the wall. If *oa* = 8 feet and *ab* = 6 feet, determine the stresses on *ob* and *oa*.

On the vertical line through *o*, set off *oc* = 5 tons; through *c* draw *cd* parallel to *oa* and meeting *ob* in *d*; then

od (by scale) = 8.3 tons = compressive stress on *ob*,

cd (by scale) = 6.6 tons = tensile stress on *oa*.

Example 3.—Fig. 19 represents a simple roof truss resting on two walls, and consisting of two rafters, *AC*, *CB*, equally

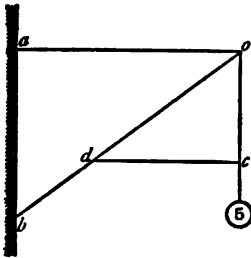

Fig. 18.

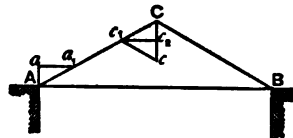

Fig. 19.

inclined to the horizontal at an angle of 30° , and a horizontal tie, *AB*, connecting the feet of the rafters together. Determine the stresses on the rafters and tie-beam, if a weight of 4 tons be placed on the apex, *C*.

The supporting force on each wall = 2 tons.

On the vertical, through *A*, set off *Aa* = 2 tons; draw *aa*₁ parallel to *AB*; then

Aa_1 = compressive stress on rafters = 4.0 tons by scale;

aa_1 = tensile stress on tie = 3.46 tons by scale.

These results may be verified analytically thus:—

$Aa_1 = Aa \times \sec. 60^\circ = 2 \times 2 = 4 \text{ tons};$

$aa_1 = Aa \times \tan 60^\circ = 2 \times \sqrt{3} = 3.46 \text{ tons, the same as}$
found by the graphic method.

Another method of graphically determining the stresses, is to set off, on the vertical through C, $Cc = 4$ tons, draw cc_1 parallel to BC, meeting AC in c_1 ; draw c_1c_2 parallel to AB, meeting Cc in c_2 ; then

compressive stress on rafters = $Cc_1 = c_1c_2 = 4$ tons, as before;
 tensile stress on tie = $c_1c_2 = 3.46$ tons, as before.

By adopting this latter plan, we are saved the trouble of finding the supporting forces at the abutments.

61. Polygon of Forces.—If any number of known forces lying in the same plane act on a point, it is always possible to find their resultant. In fig. 20 let the forces $P_1, P_2, P_3, P_4,$ and $P_5,$ be represented, both in magnitude and direction, by the straight lines $OP_1, OP_2, OP_3, OP_4,$ and $OP_5,$ and act on the point O. First find OR_1 , the resultant of P_1 and P_2 as explained for the parallelogram of forces. Next find

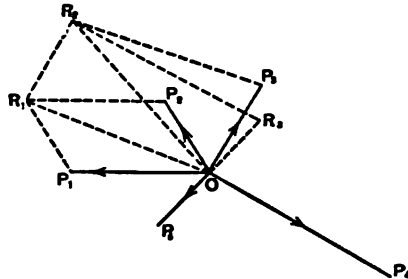

Fig. 20.

OR_2 , the resultant of OR_1 and P_3 ; OR_2 will, therefore, be the resultant of the three forces P_1, P_2, P_3 . Next find OR_3 , the resultant of OR_2 and the fourth force P_4 ; and so on. If the five forces shown, be in equilibrium, their resultant will be zero; in which case OR_3 will be in the same line with P_5 , and equal to it in magnitude. It is not necessary to construct the parallelograms in finding the successive results; the method of procedure being as follows:—

Through P_1 draw P_1R_1 equal and parallel to OP_2 ;
 through R_1 draw R_1R_2 equal and parallel to OP_3 ;
 through R_2 draw R_2R_3 equal and parallel to OP_4 ;

and so on.

If the forces be in equilibrium, $O P_1 R_1 R_2 R_3 O$ will form a closed polygon. This polygon may be drawn separately, as shown in fig. 21, by making $o_1 p_1 = P_1$, and drawing $p_1 r_1$, $r_1 r_2$, $r_2 r_3$, and $r_3 o_1$ parallel respectively to P_2 , P_3 , P_4 , and P_5 . If the forces be in equilibrium, $o_1 p_1 r_1 r_2 r_3 o_1$ will form a closed polygon.

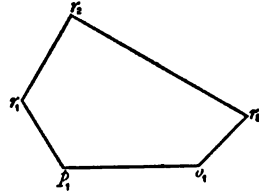

Fig. 21.

The principle of the polygon of forces, which is merely an amplification of the principle of the parallelogram of forces, may be thus stated—

If any number of forces acting on a point be in equilibrium, and lines be drawn successively in the directions of the forces and proportional to their magnitudes, these lines will form a closed polygon.

If any number of forces acting on a point be in equilibrium, and if all the forces be known both in magnitude and direction, except two, it is always possible to determine the magnitude of these when their directions are known. For it is only necessary to determine the resultant of the known forces in the manner already described. This resultant is also the resultant of the two unknown forces; so that we then have the whole system reduced to three forces in equilibrium, one of which is known, and the other two can be determined in the manner already described for the parallelogram of forces.

CHAPTER V.

EXTERNAL LOADS ON BEAMS; SUPPORTING FORCES.

62. Different Kinds of Beams.—The term *beam*, when used in connection with constructional work, is the name given to any member of the structure which is exposed to *transverse* stresses, whether the material of which it is composed be timber, iron, or steel. The term *girder* is usually restricted to beams made of iron or steel, and of a flanged form—that is, consisting of a top and bottom flange connected by a web. In this work the terms “beams” and “girders” will be used indiscriminately as meaning the same thing.

A *simple beam* or *girder* is one which is supported at its ex-

terminities and loaded at a point, or points, intermediate between them.

A *semi-beam* or *semi-girder* is a beam or girder *fixed* at one extremity only, and free at the other. The term *cantilever* is also applied to this form of beam.

A *continuous beam* or *girder* is one supported at three or more points.

Figs. 22, 23, and 24 represent the three kinds of beams referred to. A B, fig. 22, is the simple beam, which rests on the two supports, A and B, usually termed "abutments," and loaded at an intermediate point with a weight, W.

Fig. 23 represents a semi-beam or cantilever, which is fixed at one end, A, to a wall or other support, termed the abutment, and loaded at the other end, B.

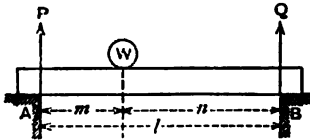

Fig. 22.

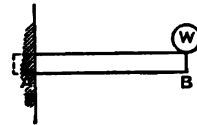

Fig. 23.

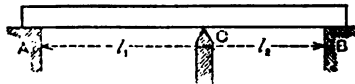

Fig. 24.

Fig. 24 represents a continuous beam resting on three supports, A, C, and B. As before, the supports, A and B, are called "abutments," while the intermediate support, C, is termed a "pier." The beams are all supposed to rest in a horizontal position, and the horizontal distances between A and B (fig. 22), and between A and C and C and B (fig. 24), are termed the "spans" of the beams.

63. **External Forces on Beams.**—When a rigid beam, as in fig. 22, is loaded at one or more points, these loads, or weights, act downward in a vertical direction, and they develop forces at A and B, which act upwards in a vertical direction. These upward forces are termed the "*reactions*" at the points of support, or *the supporting forces*. All these vertical forces are termed the *external forces acting on the beam*, in contradistinction to the

forces produced in the fibres of the beam itself, which are termed *internal forces*, and which will be treated of in a future chapter.

The forces which act downwards may, for the sake of convenience, be considered *positive*, and those which act upwards *negative*.

Since all the forces are parallel and act in one plane, there are two conditions which must be fulfilled in order that the beam may be in a condition of equilibrium:—

(1) The sum of the upward forces must be equal to that of the downward forces; or, in other words, the algebraic sum of all the forces must be zero.

(2) The sum of the moments of the forces which tend to turn the beam in *one* direction must be equal to that of those which tend to turn it in the other direction; or, the algebraic sum of the moments of the forces with reference to any point must be zero.

As regards loads on beams, there are usually recognised three varieties:—

(1) Loads concentrated at one or more points, which are known as *concentrated* loads.

(2) Loads uniformly distributed over the whole or certain parts of the beam. These are known as *uniformly-distributed* loads and are measured by so many lbs., cwts., or tons, per lineal foot of the beam or span.

(3) Loads made up of a combination of the two former, or those which are partly distributed and partly concentrated.

64. Beam Resting on Two Supports and Loaded with a Single Weight.—In fig. 22, let m and n be the segments into which the weight, W , divides the span, and let P and Q represent the reactions at the abutments or the supporting forces; then, by the conditions of equilibrium already given, we have

$$P + Q = W \quad . \quad . \quad . \quad (1),$$

and taking moments about A ; since the force, W , tends to turn the beam about this point in the direction of the hands of a clock, and the force, Q , tends to turn it in the opposite direction, we get

$$W \times m = Q(m + n) \quad . \quad . \quad . \quad (2).$$

We have here two equations, from which the values of the two unknown quantities, P and Q , may be determined. Reducing, we get

$$Q = W \cdot \frac{m}{m + n} \quad . \quad . \quad . \quad (3).$$

$$P = W \frac{n}{m + n} \quad \dots \quad (4).$$

This latter expression, giving the value of P , may also be got directly by taking moments about B .

If W is in the centre of the beam, $m = n = \frac{l}{2}$, where $l = \text{span}$.

Substituting these values in the last two equations, we get

$$P = Q = \frac{W}{2},$$

which shows that when a weight rests in the centre of the beam, the reactions at the abutments are equal to each other, each being equal to one-half the weight.

It will be noticed that in the above investigation the weight of the beam itself is not taken into consideration, and unless otherwise stated, in all future examples this will also be the case.

Example 1.—A beam, 20 feet span, supports a load of 30 tons situated at a point 7 feet from the left bearing. Find the supporting forces, or the reactions, at the bearings.

Adopting the same notation which we have just been using, we get—

$$m = 7, \quad n = 13, \quad W = 30.$$

From equations (3) and (4)—

$$Q = 30 \times \frac{7}{20} = 10.5 \text{ tons.}$$

$$P = 30 \times \frac{13}{20} = 19.5 \text{ tons.}$$

If the weight is at the centre of the beam,

$$P = Q = \frac{W}{2} = 15 \text{ tons.}$$

Example 2.—If the supporting forces at the left- and right-hand supports of a beam, 30 feet span, on which is placed a single load, be 27 and 13 tons respectively : determine the load and its position on the beam.

The load $W = P + Q = 27 + 13 = 40 \text{ tons.}$

From equation (3) (by transposing) $m = \frac{Q}{W} \times l$,

or $m = \frac{13}{40} \times 30 = 9.75$ feet; $n = 30 - 9.75 = 20.25$ feet.

The beam is, therefore, loaded with 40 tons, placed at a distance of 9.75 feet from the left support.

65. **Beam Resting on Two Supports and Loaded with Two or more Weights.**—Fig. 25 represents a beam loaded with weights,

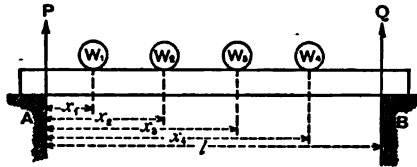

Fig. 25.

W_1, W_2, W_3, W_4 , whose distances from the left support are respectively x_1, x_2, x_3, x_4 .

Applying the two conditions of equilibrium, we get—

$$P + Q = W_1 + W_2 + W_3 + W_4 = \Sigma W \quad (5).$$

where the symbol ΣW signifies the sum of W_1, W_2, W_3, W_4 .

Taking moments about A, we get—

$$Q \times l = W_1 x_1 + W_2 x_2 + W_3 x_3 + W_4 x_4 = \Sigma W x;$$

$$\text{or, } Q = \frac{\Sigma W x}{l} \quad (6).$$

Similarly, by taking moments about B, we get—

$$P \times l = W_1(l - x_1) + W_2(l - x_2) + W_3(l - x_3) + W_4(l - x_4) = \Sigma W(l - x);$$

$$\text{or, } P = \frac{\Sigma W(l - x)}{l} \quad (7).$$

P may also be found directly from equation (5) when Q is known, and *vice versa*.

66. **Beam Resting on Two Supports and Loaded with a Distributed Weight.**—In the case of a load uniformly distributed over the whole or part of the beam, it is only necessary to find the centre of gravity of the load, and consider it as a concentrated

load acting at this point, and then to find the supporting forces (as explained in the first case).

If a beam of span, l , support a uniformly-distributed load of w tons per foot over its whole length, the total load $W = wl$, and each of the supporting forces = $\frac{wl}{2}$.

If the load only covers part of the beam, as is shown in fig. 26, the supporting forces may be found thus—

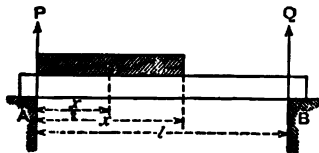

Fig. 26.

Let the left-hand portion of the beam for a distance, x , be loaded with w per foot,

$$\text{Total load } W = wx.$$

Distance of its centre of gravity from the left support = $\frac{x}{2}$.

Taking moments about A and B in succession, we get—

$$Q \times l = wx \times \frac{x}{2}, \text{ or } Q = \frac{wx^2}{2l}, \text{ and}$$

$$P \times l = wx \left(l - \frac{x}{2} \right), \therefore P = \frac{wx(2l - x)}{2l}.$$

Example 3.—The span of a beam is 52 feet, and it supports loads of 10, 15, and 20 tons, resting at points which divide the span into four equal parts. Find the pressures on the two supports.

$$\begin{aligned} W_1 &= 10. & W_2 &= 15. & W_3 &= 20. \\ x_1 &= 13. & x_2 &= 26. & x_3 &= 39. & l &= 52. \end{aligned}$$

From equations (6) and (7)

$$Q = \frac{10 \times 13 + 15 \times 26 + 20 \times 39}{52} = 25 \text{ tons.}$$

$$P = \frac{10 \times 39 + 15 \times 26 + 20 \times 13}{52} = 20 \text{ tons.}$$

$P + Q = 25 + 20 = 45$ tons, the total weight on the beam, which is a check on the result.

Example 4.—Three wheels of a locomotive rest on a girder 60 feet span. The centre of the driving wheel is 6 feet 6 inches from each of the others, and 20 feet from the left abutment, and it transmits a load of 15 tons—that transmitted by each of the others being 8 tons. Determine the pressure which the girder exerts on the abutments.

$$W_1 = 8. \quad W_2 = 15. \quad W_3 = 8. \quad \Sigma W = 31.$$

$$x_1 = 13.5. \quad x_2 = 20. \quad x_3 = 26.5. \quad l = 60.$$

$$Q = \frac{8 \times 13.5 + 15 \times 20 + 8 \times 26.5}{60} = 10\frac{1}{3} \text{ tons.}$$

$$P = 31 - 10\frac{1}{3} = 20\frac{2}{3} \text{ tons.}$$

If the weight of the girder itself be 20 tons, the total weights on the abutments, taking this into consideration, will be $20\frac{1}{3}$ tons and $30\frac{2}{3}$ tons respectively.

Example 5.—A railway train 200 feet long, and of a uniform weight of 2 tons per lineal foot, comes gradually on to a bridge of 300 feet span from the left. Find the pressure of the girders on the abutments (the weight of the bridge itself not being considered).

(1) When 150 feet of the train are on the bridge, the remainder being on the left abutment.

(2) When the whole train is on the bridge, the left-hand end being 60 feet from the left abutment.

In the first case, the weight of the train on the bridge = $150 \times 2 = 300$ tons; the centre of gravity of the load is 75 feet from the left abutment.

$$P = \frac{300 \times 225}{300} = 225 \text{ tons.} \quad Q = 300 - 225 = 75 \text{ tons.}$$

In the second case, $W = 200 \times 2 = 400$ tons.

x = distance of centre of gravity of train from left abutment = 160 feet.

$$P = \frac{400 \times 140}{300} = 186.6 \text{ tons.} \quad Q = 400 - 186.6 = 213.3 \text{ tons.}$$

If the bridge consist of two main girders, the pressures of the ends of the girders on the abutments will be *one-half* of P and Q as found, that is, supposing the rails to lie mid-way between the girders.

67. Beams projecting over one Support.—Fig. 27 is an example of a beam, $A C$, which projects over one of the supports, B , the end, C , being free. If this end be loaded with a weight, W , its

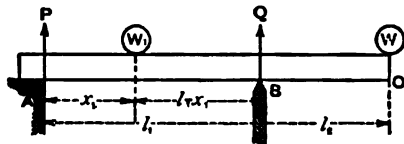

Fig. 27.

action is to cause the beam to turn round B as a fulcrum, the end A being lifted off its bearing, unless it is anchored down.

Let P = stress on the anchor bolts,

Q = reaction of the support B ,

W = weight placed on the end C .

Let $A B = l_1$ and $B C = l_2$.

Taking moments about B we get—

$$P \times l_1 = W \times l_2; \text{ or } P = \frac{W l_2}{l_1}.$$

Taking moments about A we get—

$$Q \times l_1 = W (l_1 + l_2); \text{ or } Q = W \frac{l_1 + l_2}{l_1} = W \frac{l}{l_1}$$

if $l = l_1 + l_2$.

If the beam be loaded with a second weight, W_1 , placed at a distance, x_1 , from A , we get, by the same process,

$$Q \times l_1 = W_1 x_1 + W l; \text{ or } Q = \frac{W_1 x_1 + W l}{l_1}.$$

Taking moments about B we get—

$$W_1 (l_1 - x_1) \pm P l_1 = W \times l_2; \text{ or } \pm P = \frac{W l_2 - W_1 (l_1 - x_1)}{l_1}.$$

If $W l_2$ be greater than $W_1 (l_1 - x_1)$, P will be positive, and act in a downward direction, so that, unless the beam be anchored at

this end it will be lifted off the bearing. If, on the other hand, $W_1(l_1 - x_1)$ be greater than Wl_2 , P will be negative, and will act in an upward direction. In other words, the beam will exert a downward pressure on the abutment A , and will not require to be anchored.

There will be little difficulty in finding the supporting forces in beams of this description when loaded with any number of weights, either concentrated or distributed, and placed in any position.

Example 6.—A beam, AC , 20 feet long, is supported on two bearings, A and B , in the manner shown in fig. 27, AB being equal to 12 feet and $BC = 8$ feet. The portion BC is covered with a uniform load of 50 lbs. per foot, and a concentrated load of 100 lbs. acts at a point on the beam 6 feet to the left of B . Determine the upward reaction at the bearing B , and also the nature and amount of the reaction at A .

The load on $BC = 8 \times 50 = 400$ lbs., and its centre of gravity is 4 feet to the right of B .

Taking moments about A we get—

$$Q \times 12 = 400 \times 16 + 100 \times 6; \text{ or } Q = 583.3 \text{ lbs.}$$

Taking moments about B we have—

$$P \times 12 = 400 \times 4 - 100 \times 6; \text{ or } P = 83.3 \text{ lbs.}$$

It will be necessary, therefore, to anchor the end A , the stress on the anchor bolt being 83.3 lbs.

Example 7.—In fig. 27, $l_1 = 20$ feet; $l_2 = 30$ feet; the portion AB of the beam is loaded with a distributed weight of $\frac{1}{2}$ ton per foot. The end A is anchored to the abutment by means of a single bolt 2 inches in diameter. What weight placed at the extremity of the beam C will produce a tensile stress of 5 tons per square inch on the sectional area of the bolt?

Sectional area of bolt = 3.1416 square inches.

Total stress on bolt = $5 \times 3.1416 = 15.71$ tons.

Let W = required load.

Taking moments about B , we get—

$$W \times 30 = 15.71 \times 20 + 10 \times 10; \text{ or } W = 13.8 \text{ tons.}$$

Example 8.—In fig. 27, $AB = 10$ feet. Two weights of 20 tons and 30 tons are suspended from the arm BC at distances of 15 feet and 20 feet from B respectively. The end A of the beam is anchored to the abutment by two bolts of equal diameter.

60 EXTERNAL LOADS ON BEAMS; SUPPORTING FORCES.

Determine the diameters of these bolts, so that they may be subjected to a stress of 4 tons per square inch.

If P = total stress on the bolts, by taking moments about B, we have—

$$P \times 10 = 20 \times 15 + 30 \times 20; \text{ or } P = 90 \text{ tons};$$

that is, 45 tons on each bolt.

The sectional area of each bolt = $\frac{45}{4} = 11.25$ square inches.

If x = diameter of bolts, $.7854 x^2 = 11.25$; or $x = 3.8$ inches.

68. Beams projecting over both Supports.—Fig. 28 shows an

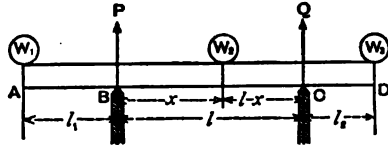

Fig. 28.

arrangement where the beam projects beyond its supports in the form of two cantilevers.

As before, let P and Q represent the supporting forces :—

Let l = length of beam between the supports;
 l_1 and l_2 = lengths of projecting arms.

W_1 and W_3 are weights placed at the extremities A and D; and W_2 is a weight resting on the central bay at a distance x from B.

It is required to determine, for a beam under these conditions, expressions for the values of the supporting forces P and Q .

Taking moments about B and C successively, we obtain—

$$Q \times l + W_1 \times l_1 = W_2 \times x + W_3 \times (l + l_2),$$

from which we obtain by reducing—

$$Q = \frac{W_2 x + W_3 (l + l_2) - W_1 l_1}{l}. \quad (8).$$

Also $P \times l + W_3 \times l_2 = W_2 (l - x) + W_1 (l + l_1)$; or

$$P = \frac{W_2 (l - x) + W_1 (l + l_1) - W_3 l_2}{l}. \quad (9).$$

From these two equations we get $P + Q = W_1 + W_2 + W_3$ which proves their accuracy.

Example 9.—A beam 50 feet long rests on two supports 20 feet apart; the left- and right-hand ends projecting beyond the supports 18 feet and 12 feet respectively. Loads of 10 and 15 tons rest on these ends, and a load of 20 tons rests on the central bay at a distance of 7 feet from the left support. Determine the supporting forces.

Referring to fig. 28, we find

$$\begin{aligned} W_1 &= 10 \text{ tons.} & W_2 &= 20. & W_3 &= 15. \\ l_1 &= 18. & l &= 20. & l_2 &= 12. & x &= 7. \end{aligned}$$

Substituting these values in equations (8) and (9), we get

$$Q = \frac{20 \times 7 + 15 \times 32 - 10 \times 18}{20} = 22 \text{ tons.}$$

$$P = \frac{20 \times 13 + 10 \times 38 - 15 \times 12}{20} = 23 \text{ tons.}$$

$$P + Q = 22 + 23 = 45 \text{ tons} = W_1 + W_2 + W_3,$$

which gives a check on the result.

Example 10.—In the last example, if the beam be loaded with a distributed weight of 3 tons per foot, determine the supporting forces.

$$\begin{aligned} W_1 &= 18 \times 3 = 54 \text{ tons.} & W_2 &= 20 \times 3 = 60 \text{ tons.} \\ W_3 &= 12 \times 3 = 36. & l_1 &= 9. & l &= 20. & l_2 &= 6. & x &= 10. \end{aligned}$$

Substituting these values in equations (8) and (9), we obtain

$$Q = \frac{60 \times 10 + 36 \times 26 - 54 \times 9}{20} = 52.5 \text{ tons.}$$

$$P = \frac{60 \times 10 + 54 \times 29 - 36 \times 6}{20} = 97.5 \text{ tons.}$$

$$P + Q = 150 \text{ tons} = \text{total load on beam.}$$

69. Continuous Beams.—In fig. 24 we have an example of a beam resting on three supports—one at each end and one intermediate. Such a beam is said to be a continuous beam of two spans. If the beam rest on four supports, it is a continuous beam of three spans; and so on.

At first sight it would appear that in beams of this class the

reactions at the various points of support would be the same as if the beam were disconnected at the points of support into a number of independent beams ; but this is not so, as will appear more clearly when we come to discuss the bending moments on continuous beams.

Consider fig. 24 to represent a beam continuous over two equal spans, l , and uniformly loaded with w per unit of length. The total weight on the beam will then be $2wl$.

If the beam be cut through at C, so as to form two independent beams, we should have—

The load on the central pier = wl .

The load on each abutment = $\frac{wl}{2}$.

If the beam be continuous, the total load on the pier and the two abutments remains the same as before, namely, $2wl$; but its distribution is quite altered.

If the central pier be a little *higher* than the side abutments, the total weight of the beam, $2wl$, will rest upon it, and there will be no pressure on the abutments. The beam would then consist of a double cantilever resting on C, the two arms being CA and CB.

If the central support be *lower* than the side supports, the total weight of the beam would be carried by the side supports alone, the pressure on each being equal to wl ; while there would be no pressure on the centre. Usually the three supports are considered to be in the same horizontal line, and the actual pressures upon them will be somewhere between the two extreme cases considered. These pressures cannot be determined by the principle of the lever, and recourse must be had to a method which involves very tedious and intricate calculations. It is not proposed to go into this analysis here ; those who wish to do so will find the subject fully treated in the works of Humber, Stoney, and other writers.

In actual practice it is not advisable to adhere too closely to merely theoretical rules in the case of continuous beams. A slight elevation or depression of one or more of the points of support will alter to a large extent the amount of the supporting forces ; and, consequently (as will be seen in a future chapter), the bending moments and stresses on the beam will also be altered.

It must be borne in mind that practically all girders are more or less flexible ; if this were not so, continuous girders could not

be employed at all, and it would be impossible to investigate their strength.

70. Continuous Beam of Uniform Section and of Two Equal Spans, each Loaded Uniformly throughout its entire Length.—In fig. 29,

Let $AC = CB = l =$ length of each span ;

$w =$ load per unit of length on AC ;

$w_1 =$ load per unit of length on CB ;

$P, R, Q =$ reactions at the three points of support, $A, C,$ and B respectively.

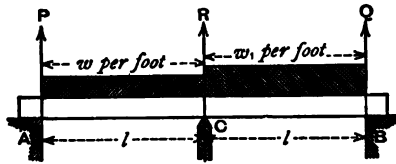

Fig. 29.

We have the following two, amongst other conditions of equilibrium :—

By taking moments about C we get—

$$P \cdot l - wl \times \frac{l}{2} = Ql - w_1 l \times \frac{l}{2} \quad . \quad (10).$$

Also, $P + R + Q = (w + w_1)l \quad . \quad (11).$

It may be shown from these, and other relationships, that

$$P = \frac{7w - w_1}{16} \cdot l \quad . \quad . \quad (12).$$

$$Q = \frac{7w_1 - w}{16} \cdot l \quad . \quad . \quad (13).$$

$$R = \frac{5}{8}(w + w_1)l \quad . \quad . \quad (14).$$

If the intensity of load on both spans be the same, we have $w = w_1$; and the supporting forces become

$$P = Q = \frac{3}{8}wl \quad . \quad . \quad (15).$$

$$R = \frac{5}{4}wl \quad . \quad . \quad (16).$$

Example 11.—A continuous girder of two equal spans, 50 feet each, is loaded with a uniform weight of 2 tons per foot on the left-hand span, and 3 tons per foot on the other span—What are the pressures on the three points of support?

We have—

$$w = 2, \quad w_1 = 3, \quad l = 50.$$

Substituting these values in equations (12), (13), and (14), we have—

$$P = \frac{7 \times 2 - 3}{16} \times 50 = 34.375 \text{ tons.}$$

$$Q = \frac{7 \times 3 - 2}{16} \times 50 = 59.375 \text{ tons.}$$

$$R = \frac{5}{8} (2 + 3) \times 50 = 156.25 \text{ tons.}$$

If this girder be divided over the central support, so as to produce two independent girders, the supporting forces would be

$$P = 50, \quad Q = 75, \quad R = 125.$$

It will be seen, therefore, that the effect of giving continuity to the girder, is to increase very much the pressure on the centre-support and to diminish it on the side-supports. In consequence of this, it is not advisable, in actual work, to use continuous girders where the foundations for the piers are unreliable. There are two reasons for this—1st, because the pressure on the pier is increased; 2nd, if the foundations subside the whole character and amount of the stresses in the main girders are altered.

Example 12.—A railway bridge, carrying a double line of rails, crosses a ravine 400 feet in clear width between the abutments. The platform is carried by two main girders, which are supported at their centres by an intermediate pier; the girders being continuous over the pier. If the dead weight of the superstructure be equal to 2 tons per foot, and the weight of a train of carriages be equal to $1\frac{1}{4}$ tons per foot; determine the pressures on the pier and abutments when the bridge is fully loaded with two trains.

$$\begin{aligned} \text{Dead load on each span} &= 200 \times 2 = 400 \text{ tons;} \\ \text{Live load on each span} &= 2 \times 200 \times 1\frac{1}{4} = 500 \text{ tons;} \\ \text{Total load on each span} &= 900 \text{ tons.} \end{aligned}$$

We have, therefore, from equations (15) and (16)—

$$\text{Total pressure on pier} = \frac{5}{4} \times 900 = 1,125 \text{ tons.}$$

$$\text{Total pressure on each abutment} = \frac{3}{8} \times 900 = 337.5 \text{ tons.}$$

71. Continuous Beam of Uniform Section and of more than Two Equal Spans, each Loaded Uniformly throughout its entire Length.—By means of the theorem of three moments, which is due to Clapeyron, the pressures on the piers and abutments of continuous beams of any number of spans, whatever may be their dimensions, and however loaded, may be calculated. The investigation is too abstruse and tedious to be introduced here. The following table, however, gives the result of these calculations up to 5 spans; the spans being all equal to each other, and the distributed load being uniform throughout.

l = length of each span.

w = load per unit of length.

TABLE XVI.

NUMBER OF SPANS.	LOADS ON THE					
	Abutment.	1st Pier.	2nd Pier.	3rd Pier.	4th Pier.	Abutment.
1	$\frac{1}{2} wl$	$\frac{1}{2} wl$
2	$\frac{3}{8} wl$	$\frac{5}{4} wl$	$\frac{3}{8} wl$
3	$\frac{4}{10} wl$	$\frac{11}{10} wl$	$\frac{11}{10} wl$	$\frac{4}{10} wl$
4	$\frac{11}{28} wl$	$\frac{32}{28} wl$	$\frac{26}{28} wl$	$\frac{32}{28} wl$...	$\frac{11}{28} wl$
5	$\frac{15}{38} wl$	$\frac{43}{38} wl$	$\frac{37}{38} wl$	$\frac{37}{38} wl$	$\frac{43}{38} wl$	$\frac{15}{38} wl$
Infinite, .	$\cdot 39 wl$	$1\cdot 13 wl$	$\cdot 96 wl$	wl	wl	$\cdot 39 wl$

From this table it will be seen that the larger the number of spans, the more equable are the loads on the piers. For all spans over five the load on each of the piers, with the exception of the first and last, is practically equal to wl ; while that on the first and the last is very little more.

Example 13.—A continuous beam of four equal spans, 20 feet each, is loaded uniformly with 5 cwt. per foot. What are the loads on the five supports?

$$w = 5 \text{ cwt. } \quad l = 20 \text{ feet. } \quad wl = 5 \times 20 = 100 \text{ cwt. } = 5 \text{ tons.}$$

$$\text{Load on 1st and 5th supports} = \frac{11}{28} \times 5 = 1.96 \text{ tons.}$$

$$\text{Load on 2nd and 4th } \quad \text{,,} \quad = \frac{32}{28} \times 5 = 5.71 \quad \text{,,}$$

$$\text{Load on 3rd } \quad \text{,,} \quad = \frac{26}{28} \times 5 = 4.64 \quad \text{,,}$$

It must be remembered that the results given in Table XVI. are based on the assumption that the beams are of uniform section throughout.

In the case of beams of *uniform strength*, that is, beams in which the strength at the different parts is made proportional to the stress coming on these parts, the results are different. For example, for a beam of uniform strength, continuous over two equal spans, l , uniformly loaded with w per foot,

$$\text{The pressure on each abutment} = \frac{1}{3}wl, \text{ and}$$

$$\text{The pressure on the central pier} = \frac{4}{3}wl.$$

CHAPTER VI.

BENDING MOMENTS FOR FIXED LOADS.

72. Definition.—When a beam resting on two supports is loaded, it becomes deflected downwards in a vertical direction; the amount of deflection being different at different parts of the

beam. A bending moment is developed at each section, and the amount of this moment is proportional to the deflection and also to the longitudinal stress existing at each section. In order to determine these stresses it will first be necessary to determine the bending moments.

When a beam is acted upon by external loads, the bending moment at a given section is equal to the sum of the moments, taken relatively to that section of all the external forces acting on the portion of the beam on either side of it.

It does not matter which segment is considered, the result being the same in both cases.

73. Bending Moments in a Beam produced by a Single Load.—The beam, A B (fig. 30), is loaded with a weight, W, at a distance, m , from the left abutment; the span of the beam being l ; it is required to determine the bending moment of the beam at the section, $a b$, situated at a distance, x , from the left abutment.

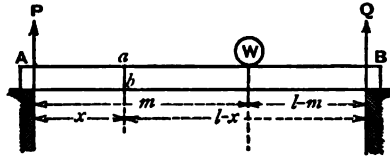

Fig. 30.

Let P and Q represent the reactions at the abutments.

The external forces acting on the segment to the left of $a b$ are represented by the single force, P; those acting on the segment to the right of $a b$ are represented by W and Q.

First consider the left segment.

Let M_{ab} = bending moment at $a b$; then from our definition

$$M_{ab} = P x, \text{ and as } P = W \frac{l - m}{l}$$

$$\text{we get } M_{ab} = W x \frac{l - m}{l} \quad (1).$$

Next consider the segment to the right of $a b$.

In this case we get $M_{ab} = Q (l - x) - W (m - x)$.

Putting for Q its value $\frac{W m}{l}$, we get

$$M_{ab} = W m \frac{l - x}{l} - W (m - x), \text{ or } M_{ab} = W x \frac{l - m}{l},$$

which is the same as that previously found.

For the given position of W , M_a , will be a maximum when x is a maximum; that is, when $x = m$.

The greatest bending moment, therefore, in a beam loaded with a single weight occurs at the point of application of the weight.

When W is expressed in tons, and the other dimensions in feet, M will be expressed in foot-tons. If W be expressed in pounds, and x , l , and m in feet, M will be expressed in foot-pounds, and so on.

Example 1.—A beam 20-feet span, supported at its extremities, is loaded with a weight of 5 tons, situated at a point 7 feet from the left abutment. Determine the bending moment at a point 12 feet from the left abutment, at the centre of the beam, and at the point of application of the load.

$$P = \frac{5 \times 13}{20} = 3.25 \text{ tons.} \quad Q = 5 - 3.25 = 1.75 \text{ tons.}$$

Let M_1 , M_2 , M_3 be the required bending moments.

$$M_1 = Q \times (20 - 12) = 1.75 \times 8 = 14 \text{ foot-tons.}$$

$$M_2 = Q \times 10 = 17.5 \text{ foot-tons.}$$

$$M_3 = P \times 7 = 22.75 \text{ ,,}$$

74. Beam Loaded with a Number of Weights.—Let W_1 , W_2 , W_3 , W_4 , W_5 , W_6 be a number of loads resting on the beam, A , B , as shown in fig. 31.

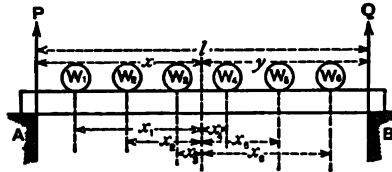

Fig. 31.

Let x = distance from the abutment, A , of the section, whose bending moment it is required to determine, and let x_1 , x_2 , - - - x_6 represent the distances of the several weights from this section. It is a matter of indifference which segment is considered; the moment of one segment is positive, and that of the other negative.

Considering left segment, we get

$$M = Px - (W_1 x_1 + W_2 x_2 + W_3 x_3).$$

Considering right segment, we get

$$M = Q(l - x) - (W_4 x_4 + W_5 x_5 + W_6 x_6).$$

If the values of P and Q be substituted in these expressions, it will be found that they are precisely the same.

If M_1, M_2, \dots, M_6 represent the bending moments at the points of application of W_1, W_2, \dots, W_6 , we get the following expressions for these moments:—

$$M_1 = P(x - x_1).$$

$$M_2 = P(x - x_2) - W_1(x_1 - x_2).$$

$$M_3 = P(x - x_3) - W_1(x_1 - x_3) - W_2(x_2 - x_3).$$

$$M_4 = Q(y - x_4) - W_6(x_6 - x_4) - W_5(x_5 - x_4).$$

$$M_5 = Q(y - x_5) - W_6(x_6 - x_5).$$

$$M_6 = Q(y - x_6).$$

Example 2.—A beam 50 feet span is loaded with weights of 5, 6, 7, and 8 tons, situated at points distant from the left abutment of 10, 25, 30, and 40 feet respectively. What are the bending moments at these points?

$$P = \frac{5 \times 40 + 6 \times 25 + 7 \times 20 + 8 \times 10}{50} = 11.4 \text{ tons.}$$

$$Q = 26 - 11.4 = 14.6 \text{ tons.}$$

$$M_5 = 11.4 \times 10 = 114 \text{ foot-tons.}$$

$$M_6 = 11.4 \times 25 - 5 \times 15 = 210 \text{ foot-tons.}$$

$$M_7 = 14.6 \times 20 - 8 \times 10 = 212 \quad ,,$$

$$M_8 = 14.6 \times 10 = 146 \text{ foot-tons.}$$

75. Diagram of Bending Moments.—The bending moments at the different sections of a beam may be found by means of a diagram. The graphic solution is often simpler and more expeditious than that obtained by algebraic methods. We propose to apply both methods in obtaining the bending moments of beams and cantilevers loaded in different ways, one being used as a check on the other. It is important to bear in mind that in order to get correct results by the graphic method, it will be necessary to draw the diagrams correctly and to a large scale.

When this is done, the results as obtained by measurement may be relied upon to the same extent as those obtained by algebraic methods.

76. Case I.—Beam supported at each end and loaded with a Single Weight.—Let A B (fig. 32) represent a beam of span, l , loaded with a weight, W , at the point, C, distant x from A. We

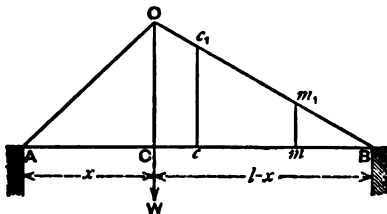

Fig. 32.

have already seen that the bending moment at C is represented algebraically by the equation $M_c = W x \frac{l-x}{l}$.

Draw a vertical line through C, and on it set off on any scale of foot-tons, $CO = W x \frac{l-x}{l}$. Join A O and O B. The triangle A O B is called the diagram of bending moments of the beam, the different ordinates of the triangle representing the bending moments at these points.

To find the bending moment at *any* point, m , it is only necessary to raise an ordinate at this point, intersecting the line O B at m_1 . The ordinate $m m_1$, so drawn, will give the bending moment at m . In the same way the bending moments at any other point of the beam may be found.

It will be seen that the maximum moment is that represented by the line O C, and this occurs at the point of application of the load. If the load be placed in the centre of the beam the diagram of moments will be represented by an isosceles triangle.

Example 3.—A beam 32 feet span is loaded with a weight of 5 tons, placed 12 feet from the left support. Draw the diagram of moments.

From equation (1) the moment at C is

$$M_c = \frac{5 \times 12 \times 20}{32} = 37.5 \text{ foot-tons.}$$

Set off, therefore, O C (fig. 32) on any scale of foot-tons = 37.5.

Join A O, O B; A O B will then represent the required diagram.

In order to find the bending moment at the centre of the beam, and a point 25 from left support, set off A c = 16 and A m = 25, and draw the verticals c c₁, m m₁. Measuring these lines on the scale for foot-tons, we find c c₁ = 30 foot-tons, and m m₁ = 13·125 foot-tons.

These results may be checked by the algebraic method thus :—

$$M_c = Q \times c B, \text{ and } M_m = Q \times m B;$$

and as
$$Q = \frac{5 \times 12}{32} = 1\cdot875 \text{ tons,}$$

$$M_c = 1\cdot875 \times 16 = 30 \text{ foot-tons,}$$

$$M_m = 1\cdot875 \times 7 = 13\cdot125 \text{ foot-tons,}$$

which confirm the previous results.

It will be seen from this that, for any beam supported at its extremities and loaded with a single weight, the bending moments at the points of support are zero, and that they gradually increase as we proceed from these points to the point of application of the load, where they become a maximum. Also, that if the beam supports a single rolling load which travels across it, the greatest bending moment occurs at its centre and is expressed by $M_{max} = W \times \frac{l}{4}$, where l = span; and the maximum bending moment at any other point distant, x , from the abutment is $M_x = W \cdot x \frac{(l-x)}{l}$.

77. Case II.—Beam supported at both Ends and loaded with two or more Weights.—The method of finding by analysis

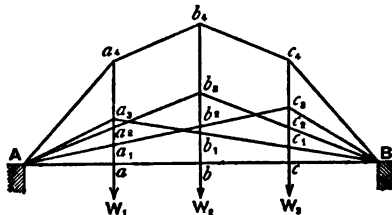

Fig. 33.

the bending moments of a beam thus loaded has been already explained. To construct a diagram of bending moments let A B

(fig. 33) represent a beam loaded with weights, W_1, W_2, W_3 , resting on the points a, b, c . Construct the diagram for each weight in succession, on the supposition that it is the *only* load resting on the beam. Each of these diagrams will be represented by a triangle. Referring to the figure, $A a_3 B$ will be the diagram for W_1 , $A b_3 B$ for W_2 , and $A c_3 B$ for W_3 . At the point a , $a a_3$ will represent the moment for W_1 , $a a_2$ that for W_2 , and $a a_1$ that for W_3 . The total moment at a will be the *sum* of these. If we set off, therefore, on the ordinate, the length $a a_4 = a a_3 + a a_2 + a a_1$, this line will represent the total bending moment at a for the three weights. In the same way make $b b_4 = b b_3 + b b_2 + b b_1$; $b b_4$ will then represent the total bending moment at b ; similarly $c c_4$ will give the total moment at c , where $c c_4$ is the sum of $c c_3, c c_2$, and $c c_1$. Join $A a_4 b_4 c_4 B$; this polygon will give the curve of bending moments of the beam when the three weights rest upon it simultaneously. The length of the ordinate from any point of the beam to the polygonal figure will give the moment at that point.

Another and more direct way of drawing the diagram curve is that shown in fig. 33a, which represents a beam, $A B$, of span l , loaded with weights W_1, W_2, W_3, W_4 , resting at the points

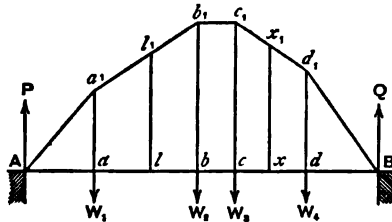

Fig. 33a.

a, b, c , and d . The bending moments at these points, when all the weights rest on the beam, are first found analytically, as already explained. Draw the ordinates $a a_1, b b_1, c c_1, d d_1$, making these lines on a scale of foot-tons equal to the moments at a, b, c, d . Join $A a_1, b_1, c_1, d_1, B$. This polygon will be the diagram for the beam.

To find the moment at any point, x , draw the ordinate $x x_1$, intersecting the polygonal curve at x_1 . The line $x x_1$ will give the moment required.

We shall illustrate this further by taking a practical example. Consider the case of a beam 50 feet span and loaded, as in example 2.

We have here—

$$W_1 = 5 \text{ tons, } W_2 = 6, \quad W_3 = 7, \quad W_4 = 8.$$

$$P = 11.4 \text{ tons.} \quad Q = 14.6 \text{ tons.}$$

$$M_a = 114 \text{ foot-tons.} \quad M_b = 210 \text{ foot-tons.}$$

$$M_c = 212 \text{ foot-tons.} \quad M_d = 146 \text{ foot-tons.}$$

Set off to scale (fig. 33a) $a a_1 = 114$, $b b_1 = 210$, $c c_1 = 212$, $d d_1 = 146$; then, as before, $A a_1 b_1 c_1 d_1 B$ represents the diagram of moments.

Since P is greater than W_1 , or, to write it more concisely, $P > W_1$, the line $a_1 b_1$ must incline upwards towards the right, and consequently the bending moment gradually increases between the points a and b ; also since $P > (W_1 + W_2)$, $b_1 c_1$ must also incline upwards from b_1 to c_1 , though only by a very small amount. Since $P < (W_1 + W_2 + W_3)$, $c_1 d_1$ must slope downwards towards the right, or the bending moment decreases between the points c and d . Lastly, since $P < (W_1 + W_2 + W_3 + W_4)$, $d_1 B$ must also slope downwards toward the right. The maximum moment occurs at that point of the polygon where one of the sides slopes *upwards* and the adjacent side slopes *downwards*. If one of the sides of the polygon be horizontal, the maximum moments occur on that portion of the beam opposite this side. It will be seen from this that if we commence at the left abutment and pass towards the right, the sides of the polygon will slope upwards towards the right when the reaction of the left abutment is greater than the sum of the weight passed, and *vice versa*. If the reaction of the abutment be *equal* to the sum of the weights passed, then the side of the polygon for that interval will be horizontal.

To find the moment at any intermediate point on the beam, say at l , where $A l = 18$ feet; draw the vertical $l l_1$, intersecting the side of the polygon at l_1 . The line $l l_1$ will represent the required moment, and by measurement we get $M_l = 165.2$ foot-tons. This result may be checked algebraically, as follows:—

$$M_l = P \times A l - W_1 \times a l = 11.4 \times 18 - 5 \times 8 = 165.2 \text{ foot-tons.}$$

78. Position of Maximum Bending Moment.—The point of a beam loaded with weights W_1, W_2, W_3 , &c., where the bending moment is a maximum, may be found by calculation thus:—Having found P , subtract the quantities W_1, W_2, W_3 , &c., from it in succession, until the remainder becomes zero, or a negative quantity. When the remainder, by adopting this process, becomes zero, there will be more than one

point of maximum bending moment, and they will occur at all sections of the beam between the position of the weight last deducted and the weight next in order. When the remainder becomes negative for the first time, there will only be one maximum bending moment, and it will occur at the weight last deducted. In the example we have just been considering, $P - W_1 = 11.4 - 5 = 6.4$, a positive quantity; $P - W_1 - W_2 = 11.4 - 5 - 6 = 0.4$, also a positive quantity; $P - W_1 - W_2 - W_3 = 11.4 - 5 - 6 - 7 = -6.6$, a negative quantity. The maximum bending moment occurs, therefore, at the point of application of W_3 , which agrees with that obtained by means of the diagram.

79. Purely Graphic Solution.—The diagrams of bending moments which have just been given do not afford a complete graphical solution of the problem, inasmuch as the moments at the points of application of the weights have first to be determined by algebraic or arithmetical calculation. It is possible, however, to dispense with these calculations and to determine the curve of moments by a *purely graphical method* only, in the following manner:—

A B (fig. 34) represents the beam. Set off to scale the points of application of the weights at a, b, c , and d . In the example

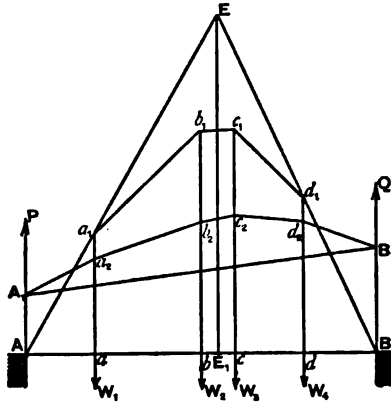

Fig. 34.

under consideration, $Aa = 10$, $ab = 15$, $bc = 5$, $cd = 10$, $dB = 10$. On the vertical line x_1x_5 (fig. 35), set off $x_1x_2, x_2x_3, x_3x_4, x_4x_5$, on a scale of tons, equal respectively to W_1, W_2, W_3, W_4 . In the present case $x_1x_2 = 5$, $x_2x_3 = 6$, $x_3x_4 = 7$, $x_4x_5 = 8$.

Take any point O and join it to the points $x_1, x_2, x_3, x_4,$ and x_5 . Through the points A, a, b, c, d, and B, in fig. 34, draw verticals. Through A_1 , any point on the vertical through A, draw $A_1 a_2$ parallel to $O x_1$, meeting the vertical through a at a_2 . In the

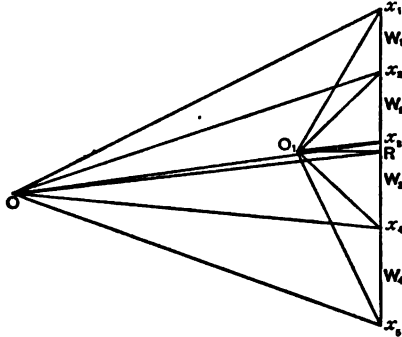

Fig. 35.

same way draw $a_2 b_2, b_2 c_2, c_2 d_2,$ and $d_2 B_1$ parallel respectively to $O x_2, O x_3, O x_4,$ and $O x_5$, meeting the ordinates through b, c, d, and B, at the points $b_2, c_2, d_2,$ and B_1 : join $A_1 B_1$. Through O draw $O R$ parallel to $A_1 B_1$, meeting $x_1 x_5$ at the point R. $x_1 R$ will then represent the reaction at the left abutment, or

$$x_1 R = P = 11.4 \text{ tons.}$$

Similarly $R x_5$ represents the reaction at the right abutment, or

$$R x_5 = Q = 14.6 \text{ tons.}$$

This is a very important solution, and shows how the supporting forces, in the case of a beam loaded with one or more weights, may be determined *graphically*.

The polygon $A_1 a_2 b_2 c_2 d_2 B_1$, represents a diagram of bending moments, but as the position of the point O (in fig. 35) is not known, the values of these moments cannot be determined by this diagram. In order to determine these values it will be necessary to construct another diagram in the following manner:—Through R draw the horizontal line $R O_1$: on this line take a distance, $O_1 R$, equal to some integral number on the scale of the horizontal dimensions of the beam. For example, make this polar distance $O_1 R = 10$, which is one-fifth the span of the beam: join $O_1 x_1, O_1 x_2, O_1 x_3, O_1 x_4,$ and $O_1 x_5$, and construct the polygon $A_1 a_1 b_1 c_1 d_1 B_1$ (fig. 34) by drawing lines parallel to these. This

polygon will represent the bending moment diagram of the beam. If correctly drawn, the last line, $d_1 B$, will come exactly to the point B. The bending moment at any point of the beam is proportional to the ordinate at that point, and its amount is determined by measuring the ordinate on the scale for vertical loads adopted in fig. 35, and multiplying the result so found by the polar distance $O_1 R$. For example, the ordinate $a a_1 = 11.4$, and multiplying this by $O_1 R = 10$, we get—

$$M_a = 11.4 \times 10 = 114 \text{ foot-tons.}$$

Proceeding in the same way for the other points we have—

$$M_b = 210 \text{ foot-tons, } M_c = 212 \text{ foot-tons, } M_d = 146 \text{ foot-tons,}$$

which agree with the results previously found by calculation. The bending moments may be found directly by measuring the ordinates on a new scale for moments. This new scale being constructed by subdividing each division on the scale for tons into 10 equal parts, as the polar distance is equal to 10 on the scale for dimensions. If the polar distance be 5 or 6, the divisions on the scale for tons must be subdivided into 5 and 6 parts respectively.

80. Graphic Determination of the Centre of Gravity of the Loads on a Beam.—The centre of gravity of the loads on the beam may be found graphically thus:—Produce the two sides, $A a_1$, $B b_1$, of the polygon in fig. 34 until they meet at E; draw the vertical $E E_1$; E_1 will be the centre of gravity of the weights W_1 , W_2 , W_3 , and W_4 .

Example 4.—A beam 60 feet span is loaded with 7, 12, 10, and 3 tons placed in order, proceeding from left to right, and dividing the span into five equal parts. Determine the point on the beam where the bending moment is a maximum.

$$P = \frac{7 \times 48 + 12 \times 36 + 10 \times 24 + 3 \times 12}{60} = 17.4 \text{ tons.}$$

$$Q = 32 - 17.4 = 14.6 \text{ tons.}$$

Deduct the first load from P; we get $17.4 - 7 = 10.4$, a positive quantity. From this amount deduct the second load, we get $10.4 - 12 = -1.6$, a negative quantity. The point of the beam, therefore, where the maximum moment occurs, is at the weight of 12 tons, or 24 feet from the left abutment.

The moments at the points of application of the different loads are thus found analytically:—

$$M_7 = 17.4 \times 12 = 208.8 \text{ ft.-tons.}$$

$$M_{12} = 17.4 \times 24 - 7 \times 12 = 333.6 \text{ ft.-tons.}$$

$$M_{10} = 17.4 \times 36 - 7 \times 24 - 12 \times 12 = 314.4 \text{ ft.-tons.}$$

$$M_3 = 17.4 \times 48 - 7 \times 36 - 12 \times 24 - 10 \times 12 = 175.2 \text{ ft.-tons.}$$

The student should check these results by the graphic method.

The bending moment at a point midway between two loads is the mean of the moments at the points of application of the loads. For example, the moment at the point midway between the loads of 12 and 10 tons in the last example

$$= \frac{333.6 + 314.4}{2} = 324 \text{ foot-tons.}$$

Example 5.—A beam 40 feet span supports four loads of 5, 1, 2, and 3 tons, situated at distances of 10, 18, 32, and 36 feet respectively from the left abutment. Find the maximum bending moment and where it occurs.

$$P = \frac{5 \times 30 + 1 \times 22 + 2 \times 8 + 3 \times 4}{40} = 5 \text{ tons.}$$

$$Q = 11 - 5 = 6. \quad P - W_1 = 5 - 5 = 0.$$

The maximum bending moments will therefore occur at the points of application of 5 and 1 tons, and at all points between them, and its amount is

$$M_{5 \text{ to } 1} = 5 \times 10 = 50 \text{ foot-tons.}$$

The bending moments at the other weights are

$$M_2 = 6 \times 8 - 3 \times 4 = 36 \text{ foot-tons.}$$

$$M_3 = 6 \times 4 = 24 \text{ foot-tons.}$$

81. Case III.—Beam Supported at both Ends, and Loaded with a Uniformly Distributed Weight.—The beam shown in fig. 36 is thus loaded—

Let l = span of beam ; w = load per unit of length ;

W = total load on the beam = wl .

The supporting force at each abutment = $\frac{wl}{2}$.

To find the bending moment at any section, aa , at a distance, x , from the left abutment, we have the segment, Aa , held in equilibrium by

(1) The upward reaction of the abutment acting at A , and equal to $\frac{wl}{2}$;

(2) By the load on the segment which equals $w x$, and which acts vertically downwards, and may be supposed to be concentrated at its centre of gravity; and

(3) By the bending moment at aa .

We have, therefore,

$$M_x = \frac{wl}{2} \times x - wx \frac{x}{2} = \frac{wx}{2} (l - x) \quad . \quad . \quad (2).$$

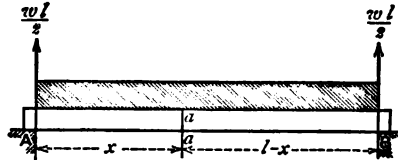

Fig. 36.

Equation (2) gives an expression for determining the bending moment at any point of a beam loaded with a uniformly distributed weight. This expression is a maximum when $x = l - x$, that is when $x = \frac{l}{2}$.

The maximum bending moment will, therefore, be at the centre of the beam, and is expressed by the formula,

$$M_{\text{cen.}} = \frac{wl^2}{8} \quad . \quad . \quad . \quad (3).$$

when $x = 0$, and $x = l$, $M_A = M_B = 0$.

The expression $M_x = \frac{wx}{2} (l - x)$ is the equation to a parabola. The diagram of bending moments for a beam supporting a distributed load will, therefore, be represented by a parabolic curve whose axis is vertical and passes through the centre of the beam.

To construct this parabola draw an ordinate through the

centre, on a scale of foot-tons = $\frac{wl^2}{8}$. This line will represent the axis of the parabola, and its highest point will be the vertex. Two other points on the curve will be those points on the beam over the edges of the abutments.

Example 6.—A girder of 60 feet span has a load of $\frac{3}{4}$ ton per foot distributed over it. Determine the bending moment at the centre of the girder, and also at points 12 feet and 24 feet from the centre.

In equation (2) we have $w = \frac{3}{4}$; $l = 60$; $x = 30, 18,$ and 6 for the three cases. Let M_1, M_2, M_3 be the three bending moments respectively.

$$M_1 = \frac{wl^2}{8} = \frac{3}{4} \times \frac{(60)^2}{8} = 337.5 \text{ foot-tons.}$$

$$M_2 = \frac{3}{4} \times \frac{18}{2} \times 42 = 283.5 \text{ foot-tons.}$$

$$M_3 = \frac{3}{4} \times \frac{6}{2} \times 54 = 121.5 \quad ,,$$

82. Beam Supported at both Ends, and Loaded with a Uniformly Distributed Weight over a certain portion of its Length next to one Support.—A B (fig. 37) is a beam of span l -feet supporting a load of w per foot, distributed over the length, a , next the

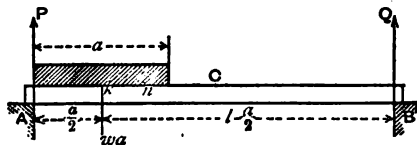

Fig. 37.

abutment, A. In order to determine the supporting forces, P and Q , this load may be supposed to be concentrated at its centre of gravity, which will be at a distance, $\frac{a}{2}$, from the left abutment

$$P = wa \frac{2l - a}{2l}; \quad Q = \frac{wa^2}{2l}.$$

To determine the bending moment at any point at a distance, x , from the left abutment, we get, when $x = a$ or when $x > a$,

$$M_x = P x - w a \left(x - \frac{a}{2} \right) = \frac{w a^2 (l - x)}{2l} \quad (4),$$

and when $x < a$ we get

$$M_x = P x - w x \frac{x}{2} = \frac{w x}{2} \left\{ \frac{a(2l - a)}{l} - x \right\} \quad (5).$$

If the load do not extend beyond the centre of the span, the maximum bending moment will be at the extremity of the load, or when $x = a$. If the load extends beyond the centre of the beam the greatest bending moment may be found thus—If C is the centre of the beam and k that of the load, set off kn , so that $kn = kC \times \frac{a}{l}$; n will be the point of the greatest bending moment.

Diagram.—To construct the diagram of bending moments for this beam. Take the line $A_1 B_1$ (fig. 38) = l . Make $A_1 C = a$; draw the ordinate $CD = \frac{w a^2 (l - a)}{2l}$ got from equation (4) by putting $x = a$. Join $A_1 D, B_1 D$.

Draw a parabola on $A_1 C$, representing the bending moments

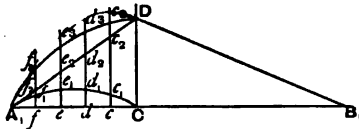

Fig. 38.

on $A_1 C$, on the supposition that it is an independent beam of span, a , supported at A_1 and C , and uniformly loaded with a weight, $w a$. Next take a number of points, c, d, e, f , on $C A_1$, and through them draw ordinates, making each ordinate equal to the sum of the ordinates of the triangle $A_1 D C$ and the parabola—for example, $c c_3 = c c_2 + c c_1$, and so on for the others. These ordinates will represent the bending moments at these points, and $A_1 f_3 e_3 d_3 c_3 D B_1$ will represent the curve of bending moments for the beam.

Example 7.—A beam, 54 feet span, is loaded uniformly for a distance of 36 feet, measured from the left abutment, with 15 cwt. per lineal foot. Find the position of the maximum bending

moment, and its amount; find also the bending moment at the centre of the beam, and draw a diagram of the curve of moments.

Referring to fig. 37, we have $l=54$, $a=36$, $w=15$, $kC=9$. If n be the point of maximum bending moment

$$kn = 9 \times \frac{36}{54} = 6, \text{ or } An = 24.$$

The maximum moment, therefore, occurs at a point 24 feet from the left abutment—

$$P = 15 \times 36 \times \frac{108 - 36}{108} = 360 \text{ cwts.}$$

$$Q = 540 - 360 = 180 \text{ cwts.}$$

From the equation

$$M_x = Px - \frac{wx^2}{2}; \text{ by putting } x=24,$$

we get

$$M_x = 360 \times 24 - \frac{15(24)^2}{2} = 4,320 \text{ foot-cwts,}$$

which is the maximum bending moment on the beam. If M_c = moment at the centre,

$$M_c = 360 \times 27 - \frac{15(27)^2}{2} = 4,252.5 \text{ foot-cwts.}$$

The bending moment at the right-hand extremity of the load, or at a point 36 feet from the left abutment, is given by equation (4).

$$M_{36} = \frac{wa^2(l-a)}{2l} = \frac{15 \times (36)^2 \times 18}{2 \times 54} = 3,240 \text{ foot-cwts.}$$

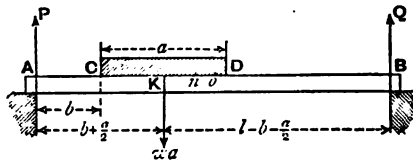

Fig. 39.

83. Beam Supported at both Ends and Loaded Uniformly over a Portion of its Length not extending to either Abutment.—Let A B

(fig. 39) represent a beam of span l , and loaded over the portion CD with a weight of w per unit of length.

Let $CD = a$, $AC = b$.

Total load on the beam = wa .

$$P = wa \cdot \frac{l - b - \frac{a}{2}}{l} \quad Q = wa \cdot \frac{b + \frac{a}{2}}{l}.$$

The bending moment at any section between A and C is given by the equation—

$$M_x = Px = \frac{wa x}{l} \left(l - b - \frac{a}{2} \right) \quad . \quad (6),$$

where x = distance of the section from the left support.

For any point between D and B

$$M_x = Q(l - x) = \frac{wa}{l} (l - x) \left(b + \frac{a}{2} \right) \quad . \quad (7).$$

For any point between C and D

$$M_x = Px - w \frac{(x - b)^2}{2} = \frac{wa x}{l} \left(l - b - \frac{a}{2} \right) - w \frac{(x - b)^2}{2} \quad . \quad (8).$$

From one of these three equations we can determine the bending moment at any section of the beam.

The maximum bending moment occurs at the point n , where

$$kn = \frac{a}{l} \times kO \quad . \quad . \quad . \quad (9).$$

where O is the centre of the beam, and k that of the load.

Diagram of Bending Moments.—Let $A_1 B_1$, fig. 40, represent

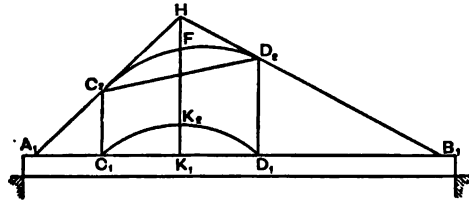

Fig. 40.

the beam; the load extending over the portion $C_1 D_1$ which is equal to a ; K_1 is the centre of $C_1 D_1$.

The moment at K_1 , on the supposition that the whole load wa is concentrated at this point, will be $= \frac{wam(l-m)}{l}$, where $A_1 K_1 = m$.

Draw the vertical, $K_1 H$, to represent this moment. Join $A_1 H$, $B_1 H$. From the extremities of the load C_1, D_1 , draw the verticals $C_1 C_2, D_1 D_2$. Join $C_2 D_2$. Next consider the portion of the beam $C_1 D_1$ as an independent beam supported at C_1 and D_1 , and loaded uniformly with the weight wa . Construct the curve of bending moments for this beam: this curve will be represented by the parabola $C_1 K_2 D_1$, whose central ordinate $K_1 K_2 = \frac{wa^2}{8}$.

By laying off ordinates from $C_2 D_2$, equal to the ordinates of the parabola $C_1 K_2 D_1$, we get for the complete curve of bending moments the curve $C_2 F D_2$, and the two straight lines $A_1 C_2, B_1 D_2$; the latter being tangents to the curve at the points C_2 and D_2 .

Example 8.—A beam 72 feet span is loaded uniformly with 1 ton per lineal foot over the portion commencing at 12 feet from the left support, and ending at the middle of the beam, or for a distance of 24 feet. Find the bending moments at each end of the load, and also the position and magnitude of the maximum bending moment.

Total load on beam $= wa = 24$ tons.

$$a = 24, b = 12, l = 72.$$

$$P = \frac{wa}{l} \left(l - b - \frac{a}{2} \right) = \frac{24}{72} \times (72 - 12 - 12) = 16 \text{ tons.}$$

$$Q = 24 - 16 = 8 \text{ tons.}$$

The moment at the point C, fig. 39, is from equation (6),

$$M_{12} = 16 \times 12 = 192 \text{ foot-tons.}$$

The moment at D is from equation (7),

$$M_{36} = 8 \times 36 = 288 \text{ foot-tons.}$$

To find the point, n , where the greatest moment occurs, we get from equation (9),

$$kn = \frac{24}{72} \times 12 = 4 \text{ feet, since } kO = 12 \text{ feet.}$$

The maximum bending moment, therefore, occurs at a point

8 feet to the left of the centre of the beam, or 28 feet from the left support.

To find its amount—

In equation (8), $P = 16$, $x = 28$, $w = 1$, $b = 12$. Substituting these values, we get

$$M_{24} = \text{max. bending mom.} = 16 \times 28 - \frac{(28 - 12)^2}{2} = 320 \text{ ft.-tons.}$$

84. Beam Supported at both Ends, and Loaded Uniformly on its Two Segments with Loads of different Intensity.—From the descriptions given in the last two cases, the student will have little difficulty in solving this problem. It is evident that if one load only be considered to act on the beam at the same time, and the bending moments at any section calculated separately for each load, then the sum of these moments will give the total moment when both loads rest simultaneously on the beam.

85. Bending Moments on Semi-Beams.—In the case of a beam supported at both ends and loaded, the particles in the top of the beam are in a state of compression and are shortened, while those in the bottom are in tension and are lengthened; so that the centre of curvature of the beam is *above* the beam. In the cantilever the reverse takes place. This distinction is recognised by treating the bending moments in the first case as positive; while in the cantilever they are negative. In continuous beams, as will be seen later on, the bending moments are partly positive and partly negative.

Girders of the cantilever form are used for a variety of purposes, as in cranes and swing bridges; and of late are coming much into use in combination with ordinary girders for bridges of large span, as in the Forth Bridge and similar structures.

86. Cantilever loaded with a Single Weight at the Free End.—In fig. 41 let AB represent a cantilever of length l , fixed in a horizontal position. At the end B is placed a weight W .

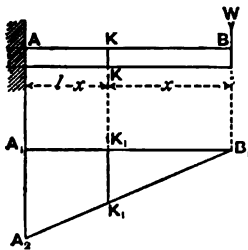

Fig. 41.

Let M_x = bending moment at the section KK , at a distance x from the end B ; then, from the definition already given for the bending moment, we get—

$$- M_x = Wx \quad (10)$$

the negative sign being used as the moment is negative. It is evident that M_x increases as x increases, and will become a maximum when $x = l$. The maximum bending

moment occurs, therefore, at the fixed end of the beam, and is expressed by $M_1 = Wl$. The moment will be a minimum when $x = 0$, that is, at the point of application of the weight.

Diagram of Bending Moments.—To construct the diagram of moments, take the horizontal line $A_1 B_1 = AB$, draw the vertical line $A_1 A_2 = -M_1$. Join $A_2 B_1$. The line $A_1 A_2$ is drawn *downwards* as the bending moment is negative. The triangle, $A_1 B_1 A_2$, is the diagram of moments for the cantilever. The moment at any section of the beam KK is represented by the ordinate $K_1 K_1$.

Example 9.—A semi-beam 15 feet long has a load of 12 cwts. resting on its free end. Determine the maximum bending moment; and also that at the centre of the beam.

The maximum bending moment occurs at the fixed end of the beam, and its amount is—

$$- M = 12 \times 15 = 180 \text{ foot-cwts.}$$

That at the centre of the beam is—

$$- M_{\text{cen.}} = 12 \times 7.5 = 90 \text{ foot-cwts.,}$$

or one-half the amount of the former.

87. Cantilever loaded with more than one concentrated Weight.—Let AB , fig. 42, be the cantilever, fixed at the end A , and

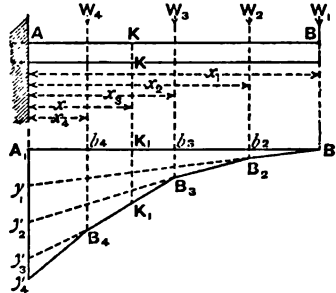

Fig. 42.

loaded with weights W_1, W_2, W_3, W_4 , applied at points of the beam situated at distances x_1, x_2, x_3, x_4 , from the fixed end. The maximum bending moment occurs at A , and is equal to the sum of the moments of each weight taken separately, and its value is—

$$- M_A = W_1 x_1 + W_2 x_2 + W_3 x_3 + W_4 x_4 = \Sigma W x \quad (11).$$

To find the moment at any section K K at a distance x from A. It is evident that all weights situated to the left of this section do not influence its bending moment; it is only those situated to the right. The total moment at K K is the sum of the moments of all the weights to the right of it taken separately, or—

$$- M_x = W_1(x_1 - x) + W_2(x_2 - x) + W_3(x_3 - x) \quad (12).$$

Diagram.—To construct the diagram of moments for this cantilever, draw the horizontal line $A_1 B_1 = A B$, and directly underneath it; on the vertical line through A_1 , set off on a scale of moments $A_1 y_1 = W_1 x_1$, $y_1 y_2 = W_2 x_2$, $y_2 y_3 = W_3 x_3$, and $y_3 y_4 = W_4 x_4$.

Join $B_1 y_1$; then $A_1 B_1 y_1$ will be the triangle of bending moments for W_1 . Draw a vertical line through W_2 , meeting $B_1 y_1$ at the point B_2 , and draw $B_2 y_2$. Join B_3 , the point of intersection of the vertical through W_3 and $B_2 y_2$, with y_3 ; and connect B_4 , the point of intersection of this line and the vertical through W_4 with y_4 . The polygonal line $B_1 B_2 B_3 B_4 y_4$ will represent the diagram of moments for the beam as loaded; and the length of the ordinate between any point of $A_1 B_1$, and this line will represent the bending moment at the section of the beam vertically over this point. The bending moment, for example, at the section K K is given by the line $K_1 K_1$. In the figure, the triangles $A_1 B_1 y_1$, $y_1 B_2 y_2$, $y_2 B_3 y_3$, and $y_3 B_4 y_4$, represent the diagrams for the weights W_1 , W_2 , W_3 , and W_4 taken separately.

The above diagram may of course be got, and perhaps more

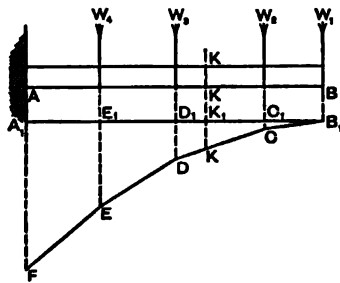

Fig. 43.

directly, by drawing the verticals $A_1 y_4$, $b_1 B_4$, $b_3 B_3$, $b_2 B_2$, equal respectively to the moments at A and at the points of application of W_4 , W_3 , and W_2 , and joining $B_1 B_2 B_3 B_4 y_4$.

The diagram of moments, as found by the methods just explained, does not give a complete graphical solution of the problem, as it involves the calculation of the moments at several sections of the beam; the purely graphical solution may be thus found:—

Graphical Solution.—In fig. 43 take the horizontal line $A_1 B_1$ to represent the length of the beam, on a scale, which may be called the scale for horizontals. The positions of the loads are shown by W_1, W_2, W_3, W_4 . Draw a vertical line, $x_1 x_5$, fig. 44, and on it measure off the distances $x_1 x_2, x_2 x_3, x_3 x_4, x_4 x_5$, to represent the weights W_1, W_2, W_3, W_4 , on a scale which may be called the scale for verticals. Measure off on the horizontal line through x_1 the polar distance $x_1 O$, equal to a convenient integral number, say 10, on the scale for horizontals. Join $O x_2, O x_3, O x_4, O x_5$. Through B_1 (fig. 43) draw $B_1 C$ parallel to $O x_2$, meeting the vertical through W_2 in C . In the same manner draw $C D, D E$, and $E F$, parallel respectively to $O x_3, O x_4$, and $O x_5$. The polygonal line $B_1 C D E F$ will give the diagram of moments; and the ordinates measured on a scale one-tenth of that for verticals, will give the bending moments at the different sections of the beam.

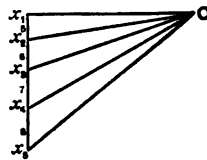

Fig. 44.

Example 10.—A cantilever, 20 feet long, supports four loads of 5, 6, 7, and 8 tons situated at distances from the fixed end of 20, 16, 10, and 5 feet respectively. Find the bending moments at the fixed end, at each weight, and at a section 12 feet from the fixed end.

$$W_1 = 5, W_2 = 6, W_3 = 7, W_4 = 8;$$

$$x_1 = 20, x_2 = 16, x_3 = 10, x_4 = 5, x = 12.$$

The bending moments are—

$$- M_0 = 5 \times 20 + 6 \times 16 + 7 \times 10 + 8 \times 5 = 306 \text{ foot-tons.}$$

$$- M_{20} = 0.$$

$$- M_{16} = 5 (20 - 16) = 20 \text{ foot-tons.}$$

$$- M_{10} = 5 (20 - 10) + 6 (16 - 10) = 86 \text{ foot-tons.}$$

$$- M_5 = 5 (20 - 5) + 6 (16 - 5) + 7 (10 - 5) = 176 \text{ foot-tons.}$$

$$- M_{12} = 5 (20 - 12) + 6 (16 - 12) = 64 \text{ foot-tons.}$$

88. Cantilever Loaded Uniformly over its Entire Length.—
Let A B (fig. 45) represent a cantilever covered with a uniformly

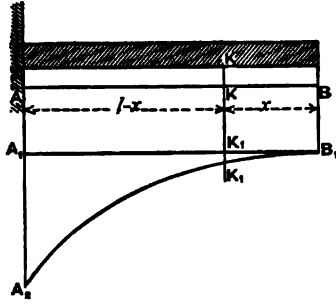

Fig. 45.

distributed load of w per unit of length. The total load $= w l$, and it may be assumed as concentrated at its centre.

$$-M_A = w l \times \frac{l}{2} = \frac{w l^2}{2} = \frac{W l}{2} \quad . \quad . \quad . \quad (14),$$

where $W = w l$.

The bending moment at a section, K K, situated at a distance, x , from B, is

$$-M_x = w x \times \frac{x}{2} = \frac{w x^2}{2} \quad . \quad . \quad . \quad (15).$$

From equation (15) it is seen that the moment increases as x increases, and becomes a maximum when $x = l$.

This equation also shows that the locus of the bending moments, represented graphically, is a parabolic curve. To construct this curve set off $A_1 A_2 = \frac{w l^2}{2}$, and draw the parabola, $B_1 K_1 A_2$; the vertex of the parabola being at B_1 , and its axis vertical. By drawing a vertical through K K, the ordinate $K_1 K_1$ will represent graphically the moment at K K.

Example 11.—A cantilever, 20 feet long, is loaded with a uniform weight of 16 cwt. per lineal foot. Determine the bending moments at 5 feet from the free end, at the middle of the beam, and at the fixed end.

From equation (15) we find that the moment at a distance of 5 feet from the end is

$$- M_5 = 5 \times 16 \times \frac{5}{2} = 200 \text{ foot-cwts.}$$

At the middle of the cantilever

$$- M_{10} = 10 \times 16 \times \frac{10}{2} = 800 \text{ foot-cwts.}$$

At the fixed end

$$- M_0 = 20 \times 16 \times \frac{20}{2} = 3,200 \text{ foot-cwts.}$$

89. Cantilever with Uniform Load, and also with a Concentrated Load at its Free End.—When a cantilever is loaded with a distributed weight of w per foot, and, in addition, a concentrated load, W , at its end, B, we get

$$- M_0 = \frac{w l^2}{2} + W l \quad . \quad . \quad . \quad (16),$$

$$- M_x = \frac{w x^2}{2} + W x \quad . \quad . \quad . \quad (17).$$

Diagram.—The curve of moments of this cantilever is a curve, the ordinates of which are equal to the *sum* of the ordinates of the diagrams for each load taken separately.

Example 12.—A cantilever, 30 feet span, is covered with a uniform load of 2 tons per foot, and, in addition, has a concentrated load of 5 tons suspended from its free end; find the maximum bending moment, and also that at the centre.

$$M_{\max.} = 2 \times 30 \times 15 + 5 \times 30 = 1,050 \text{ foot-tons,}$$

$$M_{\text{cen.}} = 2 \times 15 \times \frac{15}{2} + 5 \times 15 = 300 \text{ foot-tons.}$$

Example 13.—In the last example, what will be the bending moments if an additional concentrated load of 10 tons be placed at the centre of the cantilever?

$$M_{\max.} = 1,050 + 10 \times 15 = 1,200 \text{ foot-tons.}$$

The bending moment at the centre is not affected by this load.

90. Cantilever Loaded Uniformly over part of its Length.—Let the cantilever, A B (fig. 46), be uniformly loaded with w per foot over the length a at its free end.

$$- M_x = w a \left(l - \frac{a}{2} \right) \quad . \quad . \quad (18).$$

$$- M_x = w a \left(x - \frac{a}{2} \right) \quad . \quad . \quad (19).$$

when $x > a$, the distance x being reckoned from the free end.

$$- M_x = \frac{w x^2}{2} \quad . \quad . \quad . \quad (20).$$

when $x < a$ or $x = a$.

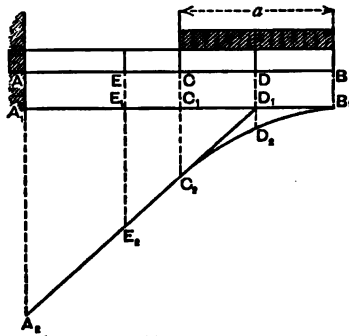

Fig. 46.

Diagram.— $A_1 B_1 = A B$, $C_1 B_1 = C B = a$.

Set off the vertical $A_1 A_2 = w a \left(l - \frac{a}{2} \right)$.

Join A_2 to the central point of $C_1 B_1$.

Draw the semi-parabola $B_1 D_2 C_2$; $C_1 C_2$ being = $\frac{w a^2}{2}$.

The diagram curve is $A_2 C_2 D_2 B_1$; which is made up of the straight line $A_2 C_2$, and the parabolic curve $C_2 D_2 B_1$, the straight line being a tangent to the curve at the point C_2 .

Example 14.—A semi-beam, 24 feet long, has a load of $1\frac{1}{2}$ tons per foot distributed over one-half the beam reckoning from the free end. Determine the bending moments at the fixed end, and at 8 feet, 12 feet, and 18 feet from the fixed end.

$$- M_0 = \frac{3}{2} \times 12 \times \left(24 - \frac{12}{2} \right) = 324 \text{ foot-tons,}$$

$$- M_8 = \frac{3}{2} \times 12 \times \left(16 - \frac{12}{2} \right) = 180 \text{ foot-tons,}$$

$$- M_{12} = \frac{3}{2} \times \frac{(12)^2}{2} = 108 \text{ foot-tons,}$$

$$- M_{18} = \frac{3}{2} \times \frac{(6)^2}{2} = 27 \text{ foot-tons.}$$

91. Beam of Uniform Section securely Fixed at the Ends and Loaded at the Centre.—When a beam, A B (fig. 47), is firmly fixed at its ends, by being built into walls or otherwise, and loaded at its centre, it will assume a shape similar to that shown by the line $A_1 B_1$, the two end portions being curved

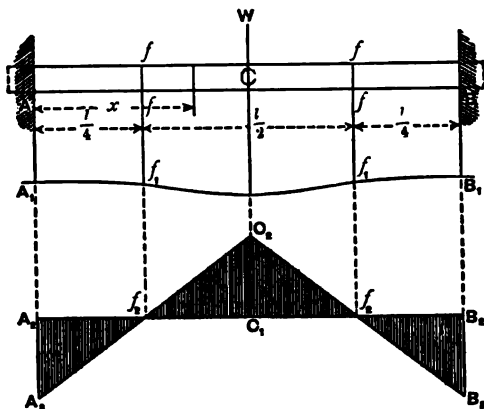

Fig. 47.

upwards and the central portion downwards; the two points, $f_1 f_1$, where the curvature alters, are called the *points of contrary flexure*, the two curves having common tangents at these points.

At the points of contrary flexure with beams of uniform section, theoretically, there is no bending moment. The beam A B may, therefore, be considered as being made up of three different beams—viz., the central beam, $f f$, and the two cantilevers, A f and B f .

It may be proved by mathematical investigation that with a beam thus fixed and loaded with a central weight, the distances, Af and Bf , of the points of contrary flexure from the near abutments are, each of them equal to $\frac{l}{4}$, where l = span of the beam, the central portion, ff , being = $\frac{1}{2}l$.

First consider the central portion, ff , which may be taken as an independent beam of span $\frac{l}{2}$ resting on two supports at f and f , and loaded at the centre with a weight, W .

The bending moment at the centre is

$$M = \frac{Wl}{8} \quad . \quad . \quad . \quad . \quad (22).$$

At a point situated at a distance, x , from the abutment

$$M_x = \frac{W}{2} \left(x - \frac{l}{4} \right) \quad . \quad . \quad . \quad (23),$$

when $x > \frac{l}{4}$.

Next consider the end portions Af , Bf . These are equivalent to cantilevers fixed at the ends, A and B , and loaded at the free ends, f , with weights $\frac{W}{2}$. The maximum bending moments of these cantilevers occur at the fixed ends, and are

$$-M_A = -M_B = \frac{Wl}{8} \quad . \quad . \quad . \quad (24).$$

The bending moments, therefore, at the centre and at the two ends are equal to each other but of opposite sign—one being positive and the others negative.

Diagram.—To construct the diagram of moments, take the line $A_1B_2 = AB$. Make A_1f_1 and B_2f_2 each equal to $\frac{l}{4}$. From C_1 , the centre of the beam, draw the vertical C_1C_2 upwards = $\frac{Wl}{8}$. C_1C_2 is drawn upwards, as the moment at C is positive. Next draw A_2A_1 and B_1B_2 downwards, making each = $-\frac{Wl}{8}$. These ordinates are drawn downwards, because the moments at A and B are negative. Join A_1C_2 and B_2C_1 ; these lines will inter-

sect $A_2 B_2$ at the points f_2, f_2 ; $f_2 C_2 f_2$ will be the triangle of bending moments for the central portion, ff , of the beam, and $A_2 f_2 A_2, B_2 f_2 B_2$ will be the triangles of bending moments for the end portions Af and Bf .

It will be seen that, taking the beam, AB , as a whole, there are three sections where the bending moments are equal—namely, at A, C , and B ; and further, the moments at these sections are greater than at any other. Also, there are two sections, namely, at the points of contrary flexure, f and f , where the bending moments are zero.

It will also be observed that a beam of uniform section with its ends firmly fixed is *twice* as strong to resist transverse stress as a beam of the same length and section whose ends are free, inasmuch as the maximum bending moment ($\frac{Wl}{8}$) in the first case is only one-half that ($\frac{Wl}{4}$) in the second case.

Example 15.—A beam, 20 feet span, has its ends firmly fixed by being imbedded in the abutments. It has a central load of 10 tons resting on it. What are the bending moments at the ends and centre of the beam; also at points distant 3 feet and 7 feet from one of the abutments?

$$-M_A = -M_B = \frac{Wl}{8} = \frac{10 \times 20}{8} = 25 \text{ foot-tons.}$$

$$+M_C = \frac{Wl}{8} = 25 \text{ foot-tons.}$$

$$-M_3 = 5 \times 2 = 10 \text{ foot-tons.}$$

$$+M_7 = \frac{W}{2} \left(x - \frac{l}{4} \right) = 5 (7 - 5) = 10 \text{ foot-tons.}$$

92. Beam of Uniform Section Fixed at the Ends and Loaded Uniformly.— AB (fig. 48) represents a beam of span, l , with its ends, A and B , firmly embedded in the abutments, and loaded uniformly over its entire length with w per foot. A beam thus loaded becomes bent in a manner similar to that in the last case, but the points of contrary flexure, f, f , do not occupy the same positions. It may be demonstrated by mathematical analysis that in beams thus fixed and loaded, the points of contrary flexure occupy positions such that

$$Af = Bf = \cdot 211 l, \text{ or } ff = \cdot 578 l$$

This beam may, therefore, be resolved into three independent ones—viz., a central beam, ff , of span = $\cdot 578 l$, resting on two supports at f, f , and loaded uniformly with w per foot; and

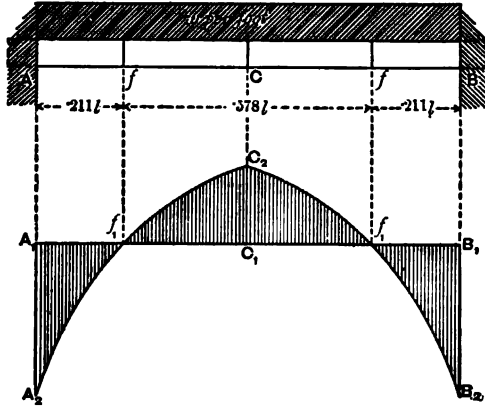

Fig. 48.

two cantilevers, Af, Bf , whose lengths = $\cdot 211 l$, and which are loaded uniformly with w per foot, and also with a concentrated load at their extremities = $\cdot 289 w l$.

To express the bending moments algebraically we have

$$M_C = \frac{w \times (\cdot 578 l)^2}{8} = \frac{w l^2}{24} \quad \dots \quad (25).$$

$$- M_A = - M_B = \frac{w \times (\cdot 211 l)^2}{2} + \cdot 289 w l \times \cdot 211 l = \frac{w l^2}{12} \quad (26).$$

$$M_x = \frac{w x}{2} (l - x) - \frac{w l^2}{12} \quad \dots \quad (27).$$

From equations (25) and (26) it will be seen that the bending moment at the centre is one-third that of the same beam free at the ends. Also, that the moment at the bearings is double that at the centre of the beam. From this it follows that the strength of a beam embedded at the ends and loaded uniformly is theoretically once and a half that of the same beam, the ends of which merely rest on the abutments.

Diagram.—Draw $A_1 B_1 = A B$, and make $A_1 f_1 = B_1 f_1 = A f = B f$.

Draw the vertical $C_1 C_2 = \frac{wl^2}{24}$, and draw the parabolic curve, $f_1 C_2 f_1$; the ordinates of this curve will give the moments at the different points of the central portion, f, f , of the beam. Next draw the verticals, $A_1 A_2, B_1 B_2$, downwards, and equal to $\frac{wl^2}{12}$, and construct the curves $A_2 f_1, B_2 f_1$. The ordinates of these curves will represent the bending moments of the ends, A, f and B, f , of the beam. The shaded portion of the fig. will represent the diagram of moments for the whole beam.

Example 16.—A beam 34 feet long, of uniform section, is loaded uniformly with a weight of 5 cwts. per lineal foot. If the beam be firmly fixed at the ends, determine the points of contrary flexure; also, the bending moments at the ends and centre, and at 4 feet from the centre.

The distances of the points of contrary flexure from the abutments = $211 \times 34 = 7.17$ feet.

Bending moment at centre,

$$M_c = \frac{wl^2}{24} = \frac{5(34)^2}{24} = 240.8 \text{ foot-cwts.}$$

Bending moment at ends,

$$-M_A = -M_B = -\frac{wl^2}{12} = 481.6 \text{ foot-cwts.}$$

At a point 4 feet from the centre, $x = 13$.

From equation (27),

$$M_x = \frac{5 \times 13}{2} \times 21 - \frac{5(34)^2}{12} = 200.9 \text{ foot-cwts.}$$

93. Beam Supported at One End and at an Intermediate Point between its Two Ends, and Loaded at the other End.—In fig. 49 let the beam A C be anchored down to the abutment at A, and rest on the pier B, and be loaded with a weight W at C.

This is precisely the same case as that of a beam resting on two abutments, and loaded with a single weight at an intermediate point, except that the bending moments in all parts of the beam are negative.

Let AB = l_1 , BC = l_2 , AC = l .

$$P = W \frac{l_2}{l_1} \quad Q = W \frac{l}{l_1}$$

The beam may also be regarded as two cantilevers, A B and B C, loaded at their free ends with P and W; the ends at B being fixed.

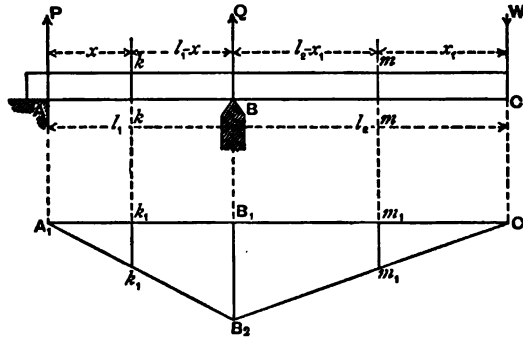

Fig. 49.

The bending moment at a distance x from A is—

$$- M_x = P x = W x \frac{l_2}{l_1} \quad (28).$$

The bending moment at a distance x_1 from C is—

$$- M_{x_1} = W x_1.$$

The maximum bending moment occurs at B, and is—

$$- M_B = P l_1 = W l_2.$$

Diagram.—To construct the diagram of bending moments. Draw $B_1 B_2$ vertically downwards equal to $W l_2$, on a scale of moments: join $B_2 A_1$, $B_2 C_1$, then $A_1 B_2 C_1$ will be the triangle of moments; the ordinate $k_1 k_1$ will represent the moment at $k k$, and $m_1 m_1$ that at $m m$. It will be noticed in this case that all the moments are negative.

If the beam be loaded in addition, with a single concentrated weight on the span A B, as shown in fig. 50, the amount and nature of the bending moments become altered. Let this weight = W_1 , placed at a distance m from A.

By taking moments about A we get—

$$Q = \frac{W (l_1 + l_2) + W_1 m}{l_1}.$$

Knowing Q , we can find the bending moment at any section of $A B$. At the point of application of W_1 , for example, we get—

$$M_{W_1} = Q(l_1 - m) - W(l_2 + l_1 - m).$$

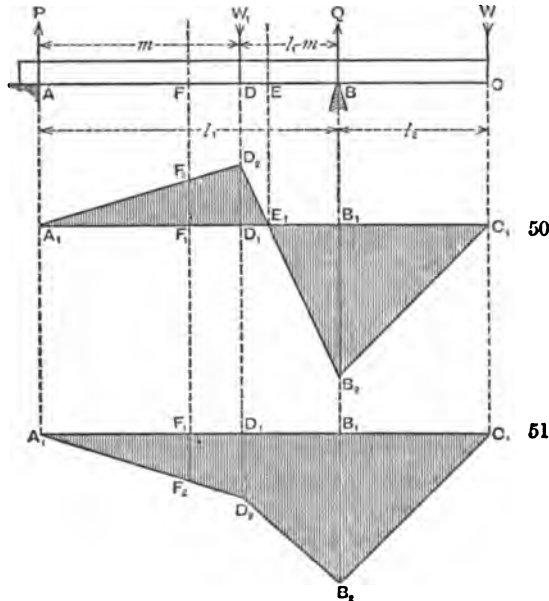

Figs. 50 and 51.

This moment is positive or negative according as

$$Q(l_1 - m) > \text{ or } < W(l_2 + l_1 - m)$$

The bending moment at W_1 may also be found in terms of P , thus—

$$M_{W_1} = P \times m, \text{ where } P = \frac{W l_2 - W_1(l_1 - m)}{l_1}$$

P acts *downwards* if $W l_2 > W_1(l_1 - m)$; and acts *upwards* if $W_1(l_1 - m) > W l_2$.

Diagram.—Draw $B_1 B_2$ downwards = $W l_2$. If the moment at D be positive, draw the vertical $D_1 D_2$ upwards, and

$$= Q(l - m) - W(l_2 + l - m).$$

Join $A_1 D_2$, $B_1 D_2$, and $B_2 C_1$. The shaded figure will indicate the diagram of bending moments, and the length of the ordinates above or below the line $A_1 C_1$ will represent the moments at the corresponding sections of the beam.

If the moment at D be negative, the ordinate at D_1 must be drawn downwards as $D_1 D_2$, in fig. 51; the bending moments throughout the beam will then be negative, and will be represented by the ordinates of the shaded diagram in fig. 51.

Example 17.—In fig. 50 $AB = 12$, $BC = 6$. A weight of 5 tons rests at C, and a weight of 12 tons at D. AD being equal to 8 feet, determine the bending moments at D and B, and at a point midway between A and B.

Referring to the equations previously given, we get—

$$Q = \frac{5 \times 18 + 12 \times 8}{12} = 15.5 \text{ tons.}$$

$$P = \frac{12 \times 4 - 5 \times 6}{12} = 1.5 \text{ tons.}$$

As P is positive it acts in an upward direction.

$$-M_B = 5 \times 6 = 30 \text{ foot-tons.}$$

$$M_D = 1.5 \times 8 = 12 \text{ foot-tons.}$$

The bending moment at the centre of AB, or at a distance of 6 feet from A, is—

$$M_c = P \times 6 = 1.5 \times 6 = 9 \text{ foot-tons.}$$

Example 18.—A beam of the same dimensions as in example 17, is loaded over AB with a distributed load of 2 tons per foot. A weight of 10 tons rests on the extremity C. Determine the bending moments at B, at the centre of AB, and at a section D, 4 feet from A.

Here we have $w = 2$, $W = 10$, $l_1 = 12$, $l_2 = 6$, $x = 4$.

$$Q = \frac{10 \times 18 + 24 \times 6}{12} = 27 \text{ tons.}$$

$$P = \frac{24 \times 6 - 10 \times 6}{12} = 7 \text{ tons.}$$

$$-M_B = 10 \times 6 = 60 \text{ foot-tons.}$$

$$M_D = Px - \frac{wx^2}{2} = 7 \times 4 - \frac{2(4)^2}{2} = 12 \text{ foot-tons.}$$

$$M_{\text{cen.}} = 7 \times 6 - \frac{2(6)^2}{2} = 6 \text{ foot-tons.}$$

To find the position of the point of contrary flexure; we obtain from equation

$$M_x = Px - \frac{wx^2}{2}$$

by making $M_x = 0$

$$Px - \frac{wx^2}{2} = 0, \text{ or}$$

$$P = \frac{wx}{2} \quad \therefore x = \frac{2P}{w} = \frac{2 \times 7}{2} = 7.$$

The point is consequently 7 feet from A.

94. Beam Supported at Two Points intermediate between the Ends.—A D (fig. 52) represents a beam supported at B and C, where $AB = l_1$, $BC = l_2$, $CD = l_3$.

First consider the case when such a beam is loaded at its extremities with two weights, W_1 and W_2 .

The values of the supporting forces at B and C are—

$$P = \frac{W_1(l_2 + l_1) - W_2 l_3}{l_2}, \text{ by taking moments about C.}$$

$$Q = \frac{W_2(l_2 + l_3) - W_1 l_1}{l_2}, \text{ by taking moments about B.}$$

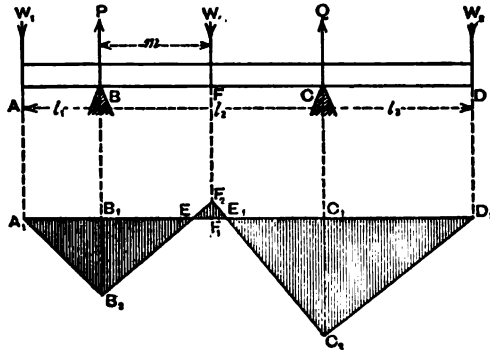

Fig. 52.

The bending moments at B and C are—

$$- M_B = W_1 \cdot l_1 \text{ or } = W_2(l_2 + l_3) - Q l_2 \quad \dots (29).$$

$$- M_C = W_2 \cdot l_3 \text{ or } = W_1(l_1 + l_2) - P l_2 \quad \dots (30).$$

The bending moment at any section of the beam situated at a distance from B = x , is

$$- M_x = W_1(l_1 + x) - P x = W_2(l_2 + l_3 - x) - Q(l_3 - x) \quad (31).$$

Example 19.—A beam, A D (fig. 52), 30 feet long, is supported at two points, B and C, so that A B = 5 feet, B C = 15 feet, C D = 10 feet. Weights of 5 tons and 4 tons rest on the extremities A and B. Draw the diagram of moments, and find the value of the bending moment at a point midway between B and C.

Using the notation previously adopted, we have

$$l_1 = 5, \quad l_2 = 15, \quad l_3 = 10, \quad W_1 = 5, \quad W_2 = 4, \quad x = 7.5.$$

Substituting these values in the previous equations, we get

$$P = \frac{5 \times 20 - 4 \times 10}{15} = 4 \text{ tons.}$$

$$Q = \frac{4 \times 25 - 5 \times 5}{15} = 5 \text{ tons.}$$

From equations (29), (30), and (31), we find

$$- M_B = 5 \times 5 = 25 \text{ foot-tons.}$$

$$- M_C = 4 \times 10 = 40 \text{ foot-tons.}$$

$$- M_{\text{cen.}} = 5 \times 12.5 - 4 \times 7.5 = 32.5 \text{ foot-tons.}$$

95.—Next consider the case of a beam similar to the last, but loaded with an additional weight, W , at a point between B and C, and at a distance, m , from the former. In fig. 52,

$$P = \frac{W(l_2 - m) + W_1(l_1 + l_2) - W_2 l_3}{l_2}.$$

$$Q = \frac{W m + W_2(l_2 + l_3) - W_1 l_1}{l_2}.$$

$$- M_B = W_1 l_1 \text{ or } = W_2(l_2 + l_3) + W m - Q l_2 \quad (32).$$

$$- M_C = W_2 l_3 \text{ or } = W_1(l_1 + l_2) + W(l_2 - m) - P l_2 \quad (33).$$

$$\pm M_F = P m - W_1(l_1 + m) \text{ or } = Q(l_2 - m) - W_2(l_2 + l_3 - m) \quad (34).$$

The value of the bending moment at any section of the project-

ing arms, A B or C D, is given by the equation

$$- M_x = W_1 x, \text{ or } - M_x = W_2 x,$$

where x = distance of the section from the end of the beam.

The general expression for the bending moment of any section of the beam between B and C, at a distance, x_1 , from B, is

$$\begin{aligned} \pm M_{x_1} &= P x_1 - W_1 (l_1 + x_1) \\ \text{or} &= Q (l_2 - x_1) - W (m - x_1) - W_2 (l_2 + l_3 - x_1) \quad (35), \end{aligned}$$

when the section lies to the left of W ; and

$$\begin{aligned} \pm M_{x_1} &= P x_1 - W (x_1 - m) - W_1 (l_1 + x_1) \\ \text{or} &= Q (l_2 - x_1) - W_2 (l_2 + l_3 - x_1) \quad . \quad . \quad (36), \end{aligned}$$

when the section lies to the right of W.

It will be seen that M_{x_1} may be positive or negative, according to the relative values of the different weights and dimensions.

It also appears that the values of the bending moments at B and C are not affected by the addition of W.

Example 20.—In the last example obtain a solution of the problem when an additional weight of 10 tons rests on the centre of B C.

$$l_1 = 5, l_2 = 15, l_3 = 10, W_1 = 5, W_2 = 4, W = 10, m = 7.5.$$

Substituting these values in equations (32), (33), (34), and the two previous ones, we obtain

$$P = \frac{10 \times 7.5 + 5 \times 20 - 4 \times 10}{15} = 9 \text{ tons.}$$

$$Q = \frac{10 \times 7.5 + 4 \times 25 - 5 \times 5}{15} = 10 \text{ tons.}$$

$$- M_B = 5 \times 5 = 25 \text{ foot-tons.}$$

$$- M_C = 4 \times 10 = 40 \text{ foot-tons.}$$

$$M_W = 9 \times 7.5 - 5 \times 12.5 = 5 \text{ foot-tons.}$$

In fig. 52, which is drawn to scale, make the vertical $B_1 B = M_B = 25$, and $C_1 C_2 = M_C = 40$. Also draw $F_1 F_2$ upwards = 5. Join $A_1 B_2, B_2 F_2, F_2 C_2, C_2 D_1$. The shaded figure will represent the complete diagram of moments.

It will be seen that the moments are negative for all parts of the beam except $E E_1$.

The points E and E₁, where B₁ F₂, C₂ F₂ intersect A₁ D₁, are the points of contrary flexure where the bending moments are zero.

To find the position of these points analytically. If x_1 = distance of E from B₁, then, since $M_{x_1} = 0$, we get from equation (35)

$$M_{x_1} = P x_1 - W_1 (l_1 + x_1) = 0;$$

or, $x_1 (P - W_1) = W_1 l_1.$

$$\therefore x_1 = \frac{W_1 l_1}{P - W_1} = \frac{5 \times 5}{9 - 5} = 6.25 \text{ feet.}$$

The point E is, therefore, distant from B₁ = 6.25 feet, which agrees with the distance as found by scale. Again, putting $x_2 = B_1 E_1$, we get from equation (36)

$$M_{x_2} = P x_2 - W (x_2 - m) - W_1 (l_1 + x_2) = 0.$$

$$x_2 (P - W - W_1) = W_1 l_1 - W m.$$

$$\therefore x_2 = \frac{W_1 l_1 - W m}{P - W - W_1} = \frac{5 \times 5 - 10 \times 7.5}{9 - 10 - 5} = 8.3 \text{ feet.}$$

The point of contrary flexure E₁ is consequently 8.3 feet from B₁.

Example 21.—In example 19 determine the bending moments of the beam if the central portion, BC, is uniformly loaded in addition with $1\frac{1}{2}$ tons per foot.

$$l_1 = 5, l_2 = 15, l_3 = 10, W_1 = 5, W_2 = 4, w = 1\frac{1}{2}.$$

Taking moments about C and B in succession, we get

$$P = \frac{5 \times 20 + \frac{3}{2} \cdot \frac{(15)^2}{2} - 4 \times 10}{15} = 15.25 \text{ tons.}$$

$$Q = \frac{4 \times 25 + \frac{3}{2} \cdot \frac{(15)^2}{2} - 5 \times 5}{15} = 16.25 \text{ tons.}$$

The bending moments, B and C, are not affected by the additional load on BC. We have, therefore, as before,

$$- M_B = 25 \text{ foot-tons,}$$

$$- M_C = 40 \text{ foot-tons.}$$

At the centre of the span, B C, $x = 7.5$ feet ;

$$\pm M_{\text{cen.}} = 15 \cdot 25 \times 7.5 - 5 \times 12.5 - \frac{3}{2} \times \frac{(7.5)^2}{2} = 9.69 \text{ foot-tons.}$$

From this it is seen that the moment at the centre is positive.

In order to find those points on the beam which have no bending moment, we must put $M_x = 0$; we then obtain—

$$P x - W_1 (l_1 + x) - \frac{w x^2}{2} = 0.$$

x being the distance of the points of contrary flexure from B.

Substituting the values of P , l_1 , &c., in this equation, we get

$$15.25 x - 5 \times 5 - 5 x - \frac{3}{2} x^2 = 0;$$

or,

$$3x^2 - 41x + 100 = 0.$$

Solving this quadratic equation, we find—

$$x = 10.5 \text{ and } x = 3.18.$$

There will be no bending moments, therefore, on those sections of the beam whose horizontal distances from B are 10.5 feet and 3.18 feet.

BENDING MOMENTS ON CONTINUOUS BEAMS.

96. Definition.—When a uniformly loaded beam is supported at its ends it becomes deflected in the manner shown in fig. 53, the upper edge of the beam being concave and the lower edge convex, and the bending moments throughout its length will be positive. If, while in this position, a central prop be placed underneath, it will assume a form similar to that shown in fig. 54. The portions A D and E B will be curved downwards, while the portion D E over the central pier will be curved upwards; the upper edge in the latter case being convex and the lower edge concave. At the two sections of the beam D and E, where the convex curve meets the concave, there will be no curvature. These are called the *sections of contrary flexure*, or the *points of contrary flexure*, or, simply, the *points of inflexion*.

The beam shown in fig. 54 may, therefore, be considered to

be made up of three separate and independent beams—viz., A D, D E, and E B.

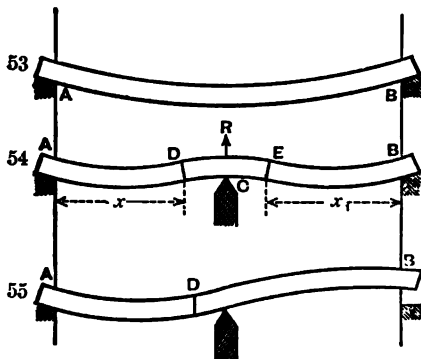

Figs. 53, 54, 55.

A D and E B are supported at their extremities, and D E is supported in the middle in the form of a double cantilever. The bending moments throughout A D and E B are *positive*; while those in D E are *negative*. At the points of contrary flexure, D and E, there are no bending moments; there being only *shearing* actions at these sections.

With a stationary load, the positions of D and E remain stationary, and when the load is uniformly distributed, the distances of D and E, from the central support, are the same when the two spans are equal. With a passing load, the points of inflexion change with each position of the load. This complicates the question a good deal. If the left-hand span be loaded more than the right, it has the effect of moving the points of inflexion towards the right. If this preponderance of loading be great, the right-hand portion may be lifted altogether off the abutment, as shown in fig. 55. In this case, instead of there being three independent beams, there will only be two—namely, A D and D B. In the first the bending moments will be positive, and in the second negative.

Referring to fig. 54, if the beam be uniformly loaded, the reactions at the abutments, A and B, will be equal to one-half the loads on A D and E B respectively, and the reaction at the central support, C, will be equal to the load on D E *plus* one-half the loads on A D and E B. The amount of these reactions for beams of equal section has been given in Chapter V.

97. **Determination of the Position of the Points of Inflexion of Continuous Beams of two equal Spans and of Uniform Section.**—When the reactions at the different points of support of a continuous beam are known, it is a simple matter to determine the points of contrary flexure.

Let $A C = C B = l$,
 w = distributed load per unit of length in $A C$,
 w_1 = " " " " " " " " $C B$,
 P, R, Q = reactions at the " points of " support, A, C, B ,
 respectively,
 x and x_1 = horizontal distances of the points of inflexion,
 D and E , from A and B respectively ;

Then, since P = half the load on $A D$, we have—

$$P = \frac{w x}{2}, \text{ or } x = \frac{2 P}{w} \quad . \quad . \quad (37).$$

In the same manner it may be shown that

$$x_1 = \frac{2 Q}{w_1} \quad . \quad . \quad . \quad (38).$$

Substituting the values of P and Q , as given in equations (12) and (13), Chapter V., we find—

$$x = \frac{7 w - w_1}{8 w} \cdot l \quad . \quad . \quad (39).$$

$$x_1 = \frac{7 w_1 - w}{8 w_1} \cdot l \quad . \quad . \quad (40).$$

$$\text{If } w = w_1, \text{ then } x = x_1 = \frac{3}{4} l \quad . \quad . \quad (41).$$

We have this general rule, therefore, *that in continuous beams of uniform section of two equal spans and uniformly loaded, the distance of each point of inflexion from the near abutment is equal to three-fourths of the span ; or the distance from the central pier is equal to one-fourth of the span.*

98. Bending Moments in a Continuous Beam of two equal Spans, and of Uniform Section.—When the positions of the points of inflexion are known, there is little difficulty in finding the curve of bending moments.

In fig. 54 let w and w_1 be the weights per unit of length on $A C$ and $C B$.

There are three maximum bending moments on the beam, occurring at the centres of $A D$ and $E B$, and at C .

Let M_H = bending moment at the centre of $A D$,
 M_K = bending moment at the centre of $E B$,
 M_C = bending moment at C .

A D and E B are uniformly loaded with $w x$ and $w_1 x_1$ respectively.

The arm D C of the cantilever is loaded with $\frac{w x}{2}$ at its extremity; and $w (l - x)$ distributed over it.

The arm C E is loaded with $\frac{w_1 x_1}{2}$ at its extremity, and $w_1 (l - x_1)$ distributed over it.

We have, therefore, as the values of the maximum moments

$$+ M_H = \frac{w x^2}{8} \quad \dots \quad (42).$$

$$+ M_K = \frac{w_1 x_1^2}{8} \quad \dots \quad (43).$$

$$- M_C = \frac{w x}{2} \cdot (l - x) + \frac{w (l - x)^2}{2} = \frac{w l (l - x)}{2} \quad (44).$$

$$\text{Also - } M_C = \frac{w_1 l (l - x_1)}{2}.$$

By substituting the values of x and x_1 given in equations (39) and (40), we get the bending moments in terms of w , w_1 , and l .

If $w = w_1$, then $x = x_1 = \frac{2}{3} l$. Substituting these values in equations (42), (43), (44), we obtain—

$$M_H = \frac{9 w l^2}{128} \quad \dots \quad (45).$$

$$M_K = \frac{9 w l^2}{128} \quad \dots \quad (46).$$

$$- M_C = \frac{w l^2}{8} \quad \dots \quad (47).$$

We thus see that in a continuous girder of two equal spans uniformly loaded, the maximum bending moment occurs over the central pier, and is greater than the maximum bending moment of the two spans in the proportion of 16 to 9.

Diagram.—The diagram of moments for the beam we have just been considering is shown in fig. 56, and may be constructed thus:—

$A_1 B_1$ is drawn equal to $A B = 2 l$;

$A_1 D_1 = \frac{2}{3} l$, $D_1 E_1 = \frac{1}{3} l$, $E_1 B_1 = \frac{2}{3} l$.

$H_1, C_1, K_1,$ are the centres of $A, D_1, D_1 E_1,$ and $E_1 B_1$ respectively. Draw $H_1, H_2,$ and $K_1, K_2,$ vertically upwards, and equal to $\frac{9 w l^2}{128},$ on a

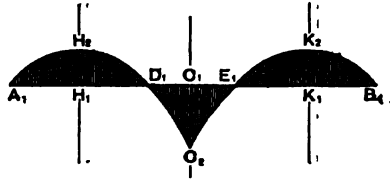

Fig. 56.

scale of moments, and construct the parabolic curves $A_1 H_2 D_1,$ and $E_1 K_2 B_1;$ the ordinates of these curves will represent the moments at the corresponding points of $A D$ and $E B,$ and are all positive. Next draw $C_1 C_2$ vertically downwards, making it = $\frac{w l^2}{8}$ on the same scale of moments.

Draw the curves $D_1 C_2, E_1 C_2;$ the figure $D_1 C_2 E_1$ represents the diagram of moments for the portion $D E$ of the beam.

99. Bending Moments in a Continuous Beam of Two Equal Spans, and of Uniform Strength throughout its Length.—In beams of *uniform strength* the supporting forces are (see page 66)—

$$P = Q = \frac{w l}{3}$$

$$R = \frac{4}{3} w l,$$

when loaded with a uniform load of w per unit of length.

$$\text{Also, } x = x_1 = \frac{2}{3} l.$$

We, therefore, have for the bending moments at $H, K,$ and C —

$$+ M_H = \frac{w l^2}{18} \quad (48).$$

$$+ M_K = \frac{w l^2}{18} \quad (49).$$

$$- M_C = \frac{w l^2}{6} \quad (50).$$

In this case the bending moment at C is to that at H or $K,$ as 3 is to 1.

The diagram of moments for this beam may be constructed in a precisely similar manner to that in the last case.

100. Girders of Uniform Strength.—As continuous girders of

large span in actual practice are designed approximately of uniform strength throughout (that is, the section of the different parts of the flanges are made proportional to the stresses to which they are exposed), it is evident that the solution just given will be more applicable than that given for girders of uniform section. It must be borne in mind, however, that, owing to the shifting position of the rolling load, the points of contrary flexure and also the pressures on the supports vary, and the girder must be so designed as to meet all these variations. If the piers sink ever so little, the character and amount of the stresses will be quite altered. Such being the case it is always advisable to allow a considerable margin of strength in continuous girders over and above that which theory indicates.

Example 22.—A girder of uniform section is continuous over two spans of 100 feet each, and is uniformly loaded with $1\frac{1}{2}$ tons per foot. What are the maximum positive and negative bending moments of the girder and the pressures on the supports?

Here we have $w = 1\frac{1}{2}$, $l = 100$.

Pressure on abutments are (see Table XVI.)—

$$P = Q = \frac{3}{8} w l = \frac{3}{8} \times \frac{3}{2} \times 100 = 56.25 \text{ tons.}$$

Pressure on central pier—

$$R = \frac{5}{4} w l = \frac{5}{4} \times \frac{3}{2} \times 100 = 187.5 \text{ tons.}$$

Distance of points of inflexion from near abutment is

$$x = \frac{3}{4} l = 75 \text{ feet.}$$

The positive maximum bending moments occur at a distance of 37.5 feet from each abutment, and their values from equations (45) and (46) are—

$$M_H = M_K = \frac{9 w l^2}{128} = \frac{9 \times \frac{3}{2} \times (100)^2}{128} = 1054.7 \text{ foot-tons.}$$

The maximum negative moment occurs over the central pier, and from equation (47) its value is

$$- M_C = \frac{w l^2}{8} = \frac{\frac{3}{2}(100)^2}{8} = 1875 \text{ foot-tons.}$$

Example 23.—If in the last example the girder be of uniform strength throughout, determine the solution.

$$\text{In this case } = P \quad Q = \frac{wl}{3} = \frac{\frac{3}{2} \times 100}{3} = 50 \text{ tons.}$$

$$R = \frac{4}{3}wl = \frac{4}{3} \times \frac{3}{2} \times 100 = 200 \text{ tons.}$$

Distance of points of inflexion from near abutment is

$$\frac{2}{3}l = 66.6 \text{ feet.}$$

The maximum positive bending moments occur at a distance of $\frac{66.6}{2} = 33.3$ feet from each abutment, and their values are from equations (48) and (49).

$$+ M_H = + M_K = \frac{wl^2}{18} = \frac{\frac{3}{2}(100)^2}{18} = 833.3 \text{ foot-tons.}$$

The maximum negative bending moment is, from equation (50),

$$- M_C = \frac{wl^2}{6} = \frac{\frac{3}{2}(100)^2}{6} = 2500 \text{ foot-tons}$$

Example 24.—Determine the positions of the points of contrary flexure and the bending moments of the beam in *Example 11* Chap. V., and draw a diagram of the same.

$$w = 2, w_1 = 3, l = 50.$$

$$P = 34.375, Q = 59.375, R = 156.25.$$

The first thing to be done is to find the points of inflexion. These are determined from equations (39) and (40).

$$x = \frac{7w - w_1}{8w} \cdot l = \frac{7 \times 2 - 3}{8 \times 2} \times 50 = 34.375 \text{ feet.}$$

$$x_1 = \frac{7w_1 - w}{8w} \cdot l = \frac{7 \times 3 - 2}{8 \times 3} \times 50 = 39.58 \text{ feet.}$$

From equations (42), (43), and (44) we get the maximum bending moments as follows:—

$$+ M_R = \frac{w x^2}{8} = \frac{2(34.375)^2}{8} = 295.4 \text{ foot-tons.}$$

$$+ M_K = \frac{w_1 x_1^2}{8} = \frac{3(39.58)^2}{8} = 587.5 \text{ foot-tons.}$$

$$- M_C = \frac{w l (l - x)}{2} = \frac{2 \times 50 \times 15.625}{2} = 781.25 \text{ foot-tons.}$$

$$\text{Also, } - M_C = \frac{w_1 l (l - x_1)}{2} = \frac{3 \times 50 \times 10.42}{2} = 781.25 \text{ foot-tons,}$$

which proves the correctness of the results.

Example 25.—In the last example determine the solution when the beam is covered with a uniform load of $2\frac{1}{4}$ tons per foot.

Here we have

$$w = w_1 = 2.5, l = 50.$$

$$P = Q = \frac{3}{8} \times 2.5 \times 50 = 46.875 \text{ tons,}$$

$$R = \frac{5}{4} \times 2.5 \times 50 = 156.25 \text{ tons,}$$

$$x = x_1 = \frac{3}{4} \times 50 = 37.5 \text{ feet.}$$

$$M_R = M_K = \frac{9 \times 2.5 (50)^2}{128} = 439.5 \text{ foot-tons,}$$

$$- M_C = \frac{2.5 (50)^2}{8} = 781.25 \text{ foot-tons.}$$

In this example the total load on the beam is the same as in the last, but differently distributed.

The distances of the points of inflexion from the abutments are a mean of those in the last case, so also is the positive maximum bending moment, while the negative maximum moment remains the same.

CHAPTER VII.

BENDING MOMENTS FOR MOVING LOADS.

101. *Definition.*—A *moving or travelling load* on a beam is one which occupies different positions at different times. The terms

live load and *rolling load* are also used to designate this class of loads. An example of a moving load on a bridge is a railway train as it passes over it. The length of load may be equal to or greater than the span of the bridge, or it may be less. In the former case, at some moment the span will be loaded throughout its entire length. A moving load affects a beam both *statically* and *dynamically*. The latter plays an important part in the case of bridges of small span, when the velocity of the rolling load is great; and its effect must be taken into account. This will be treated of in Chapter XXIII. In the present chapter the statical effect only of moving loads will be considered.

102. Beam supported at Both Ends, and exposed to a Uniform Moving Load, less in Length than the Span.—In fig. 57 let the beam A B be exposed to a uniform load moving over it. Each section of the beam will have a different bending moment according to the different positions which the load occupies relatively to the section. An important case is to determine what position of the load will produce the maximum bending moment on any particular section of the beam. This we will now proceed to investigate.

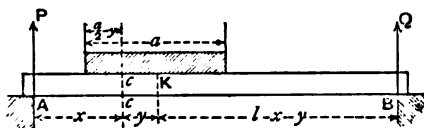

Fig. 57.

Let l = span of the beam,

a = length of the load,

w = weight of load per unit of length,

x = distance of section $c c$ of beam from A,

y = distance of this section from the centre of gravity of the load.

The total load = $w a$, and its centre of gravity is K. As in previous chapters, P and Q represent the reactions at the abutments

$$P = \frac{w a (l - x - y)}{l},$$

$$Q = \frac{w a (x + y)}{l}.$$

Considering the portion of the beam to the left of cc , and taking moments, we get—

$$M_x = Px - \frac{w}{2} \left(\frac{a}{2} - y \right) \left(\frac{a}{2} - y \right).$$

Substituting for P , its value, we get—

$$M_x = \frac{w a (l - x - y)}{l} \cdot x - \frac{w}{8} (a - 2y)^2.$$

$$= \frac{w a x}{l} (l - x) - \frac{w a^2}{8} + \frac{w}{2} \left(a - \frac{2 a x}{l} - y \right) y \quad (1).$$

This is the general equation for the bending moments. To find the position of the load, so that this expression may be a maximum, we must find the value of y , which makes it so.

M_x will be a maximum when the expression

$$\left(a - \frac{2 a x}{l} - y \right) y$$

is a maximum, and this will occur when the two factors of this expression are equal to each other, or when

$$a - \frac{2 a x}{l} - y = y,$$

that is, when

$$y = \frac{a(l - 2x)}{2l} \quad (2).$$

This equation gives us the distance of the centre of the load from cc when the bending moment at that section is greatest.

To find the maximum bending moment at cc , substitute the value of y , given in equation (2), in equation (1), and we get, by reducing,

$$M_x = \frac{w a x}{2 l^2} (l - x) (2 l - a) \quad (3).$$

This is the equation of the maximum bending moments in the beam during the passage of the load. The locus of these moments, plotted graphically, may be shown to lie in a parabolic curve, the apex being above the centre of the span. The maximum of these maxima occurs at the centre of the span, and its value may be found analytically from equation (3) by putting $x = \frac{l}{2}$. Making this substitution, we get

$$M_{\text{max}} = \frac{w a}{8} (2 l - a) \quad (4).$$

The graphic representation of the maximum bending moments of the beam, under consideration, may be found by erecting an ordinate at the centre $= \frac{w a}{8}(2l - a)$ and drawing a parabolic curve passing through the end of this ordinate and the extremities of the beam.

Example 1.—An advancing load, 20 feet long, of 3 tons per foot, comes on to a beam 50 feet span from the left abutment. What are the maximum bending moments—(1) at 15 feet from the left abutment, and (2) at the centre of the span? and what must be the positions of the load to produce these moments?

$$w = 3, \quad x = 15 \text{ and } x = 25, \quad l = 50, \quad a = 20.$$

To find the positions of the load, which produce the maximum bending moments, substitute the above values in equation (2), and we find

$$y = \frac{20(50 - 2 \times 15)}{2 \times 50} = 4 \text{ in the first case.}$$

That is, the centre of the load is 4 feet to the right of the section or 19 feet from the left abutment.

In the second case, putting $x = 25$ in equation (3), we get $y = 0$, or the centre of the load is at the centre of the beam.

In the first case the maximum moment is, from equation (3),

$$M_{15} = \frac{3 \times 20 \times 15}{2(50)^2} \times 35 \times 80 = 504 \text{ foot-tons.}$$

In the second case, from equation (4), we get

$$M_{\text{cen.}} = \frac{3 \times 20}{8}(100 - 20) = 600 \text{ foot-tons.}$$

Example 2.—A railway train, 200 feet long, weighing $1\frac{1}{4}$ tons per foot, comes from the left on to a bridge 300 feet span consisting of two main girders. What must be the position of the train on the bridge to produce maximum bending moments on the girders at sections 50 feet from the left abutment?

For each girder we have—

$$w = \frac{5}{8}, \quad x = 50, \quad l = 300, \quad a = 200.$$

Substituting these values in equation (2), we obtain—

$$y = \frac{200 \times 200}{2 \times 300} = 66.6 \text{ feet.}$$

wrong! } The centre of the train must, therefore, be 66·6 feet to the left of the centre of the girder, or 83·3 feet to the right of the left abutment. There will be, therefore, only 183·3 feet of the train resting on the bridge, when the maximum bending moments occur at the sections indicated.

103. Beam Supported at both Ends, and exposed to a Single Concentrated Rolling Load.—A single concentrated rolling load W passes over a beam of span l .

The maximum bending moment at any section of the beam, whose distance from the left abutment = x , occurs when the load rests on this section.

$$P = W \frac{l - x}{l} \quad Q = W \frac{x}{l}$$

$$M_x = Px = Q(l - x) = W \cdot \frac{x(l - x)}{l} \quad (5).$$

M_x will be a maximum when $x(l - x)$ is a maximum; that is, when $x = l - x$, or $x = \frac{l}{2}$, which is at the centre of the beam.

The locus of the maximum bending moments is a parabola, the apex of which is above the centre of the span, and the central ordinate = $\frac{Wl}{4}$, which value is obtained by substituting $x = \frac{l}{2}$ in equation (5).

Example 3.—A single load of 10 tons rolls over a girder 50 feet span. Determine the maximum bending moments at intervals of 10 feet.

$$l = 50; \quad x = 10, 20, 30, 40; \quad W = 10.$$

$$M_{10} = \frac{10 \times 10 \times 40}{50} = 80 \text{ foot-tons,}$$

$$M_{20} = \frac{10 \times 20 \times 30}{50} = 120 \text{ foot-tons,}$$

$$M_{30} = \frac{10 \times 30 \times 20}{50} = 120 \text{ foot-tons,}$$

$$M_{40} = \frac{10 \times 40 \times 10}{50} = 80 \text{ foot-tons.}$$

$$M_{\text{cen.}} = \frac{10 \times 50}{4} = 125 \text{ foot-tons.}$$

104. Beam Supported at both Ends and exposed to a Rolling Load consisting of two Concentrated and Equal Weights, at a

fixed interval apart.—In fig. 58 the two equal loads, W, W , at a fixed distance, a , apart—resembling the wheels of a truck—pass over the beam $A B$. The problem we give ourselves to investigate is—What must be the position of the loads on the beam in order to produce the maximum bending moment on a section $b b$, situated at a distance, x , from the left support?

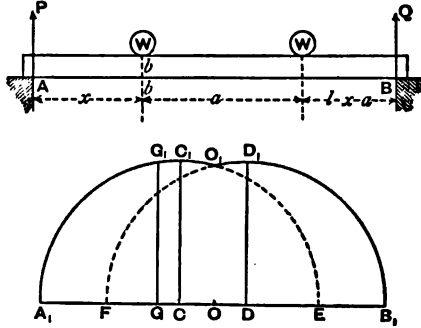

Fig. 58.

First consider the case when the left weight rests on b .

$$P = \frac{W}{l} (2l - 2x - a).$$

$$Q = \frac{W}{l} (2x + a).$$

$$M_x = Px = \frac{Wx}{l} (2l - 2x - a) \quad . \quad (6).$$

If the load travel to the right, P diminishes, and consequently the bending moment at $b b$; so that when one weight rests on b , the bending moment at that point is greater than for any position of this weight to the right of b .

Next consider the weights to be moved to the left so that the left weight is at a distance x_1 from b .

In this case we have

$$P = \frac{W}{l} \{2l - (2x - 2x_1) - a\}.$$

$$Q = \frac{W}{l} (2x - 2x_1 + a).$$

$$M'_x = Px - Wx_1.$$

$$= \frac{Wx}{l} \{2l - 2x + 2x_1 - a\} - Wx_1.$$

$$= \frac{Wx}{l} (2l - 2x - a) - Wx_1 \left(1 - \frac{2x}{l}\right).$$

$$= M_x - Wx_1 \left(1 - \frac{2x}{l}\right) \quad . \quad (7).$$

From this equation it will be seen that $M_x > M'_x$ if the expression $W x_1 \left(1 - \frac{2x}{l}\right)$ be positive, and this is the case so long as $1 > \frac{2x}{l}$, that is, for all values of x which are less than $\frac{l}{2}$; when $x = \frac{l}{2}$, $M'_x = M_x$.

From this investigation it will be apparent that, in a beam exposed to a rolling load consisting of two equal weights placed at a fixed distance apart, the maximum bending moment on any section of the left half of the beam occurs when the left weight rests on this section; and the maximum moment on any section of the right portion occurs when the right weight rests on the section. Also, the maximum bending moment at the centre of the beam occurs when either weight rests on the centre, or when one weight rests at one side of the centre and the second weight on the other side. The general equation to the maxima bending moments of the left half of the span is $M_x = \frac{2Wx}{l} \left(l - x - \frac{a}{2}\right)$.

The locus of these moments is a parabola with its axis vertical. To find the apex of this parabola we must determine at what point of the left half of the span the maximum of these maxima bending moment occurs. In other words, what value of x will make M_x a maximum? This will occur when $x \left(l - x - \frac{a}{2}\right)$ is greatest, and, as the sum of these two factors is constant, the expression will be a maximum when both factors are equal to each other, or $x = \frac{l}{2} - \frac{a}{4}$. A similar result will be obtained for the right hand half of the span. We have, therefore, the following general rule:—

When two equal concentrated loads, separated by a constant distance, a , roll over a beam, there will be two points in the beam where the bending moments will be a maximum; these points are situated at each side of the centre of the span, and at distances from it equal to one fourth of the distance between the two weights.

In order to determine the value of these moments we must substitute for x its value $\left(\frac{l}{2} - \frac{a}{4}\right)$ in the general equation (6), and we obtain—

$$M_{\max.} = \frac{W}{8l} (2l - a)^2 \quad . \quad . \quad . \quad (8).$$

To find the bending moment at the centre of the beam, substitute $\frac{l}{2}$ for x in equation (6), when we get

$$M_{\text{cen.}} = \frac{W}{2}(l - a) \quad . \quad . \quad . \quad (9).$$

105. *Diagram.*—When $a = \frac{l}{2}$, or $a < \frac{l}{2}$, the diagram of moments may be constructed thus:—Draw the horizontal line, $A_1 B_1$, (fig. 58a) to any scale, equal in length to the beam. From its centre, O , lay off $O C = O D = \frac{a}{4}$; the maximum bending moments will occur at C and D , and may be found by means of equation (8). Draw the verticals $C C_1$, $D D_1$, equal to these moments on a scale of bending moments, and construct the parabolic curves $A_1 C_1 E$ and $B_1 D_1 F$, intersecting at the point O_1 ; then $A_1 C_1 O_1 D_1 B_1$ will represent the diagram of maximum bending moments for the beam during the passage of the load. The maximum moment at any point, such as G , is at once found by measuring the ordinate $G G_1$ at this point.

Example 4.—Two wheels of a loaded truck pass over a beam 30 feet span. If the load on each wheel be 5 tons, determine the maximum bending moment on the beam, and also the bending moment at its centre, the wheels being 10 feet apart—

$$W = 5, \quad l = 30, \quad a = 10.$$

As a is less than $\frac{l}{2}$, the maximum moments occur at the two points of the beam situated at a distance of 2.5 feet at each side of the centre. Their values are found from equation (8), viz:—

$$M_{\text{max.}} = \frac{W}{8l}(2l - a)^2 = \frac{5}{8 \times 30}(2 \times 30 - 10)^2 = 52.08 \text{ foot-tons.}$$

The maximum moment at the centre of the beam is found from equation (9), viz:—

$$M_{\text{cen.}} = \frac{W}{2}(l - a) = \frac{5}{2}(30 - 10) = 50 \text{ foot-tons.}$$

Example 5.—In the last example, determine the greatest bending moment at a section 8 feet from the left abutment.

The greatest bending moment at this section will occur when

the left wheel rests upon it, and its value is found from the general equation—

$$M_x = \frac{2}{l} W x \left(l - x - \frac{a}{2} \right), \text{ where } x = 8.$$

Substituting this and reducing, we find

$$M_x = 45.3 \text{ foot-tons.}$$

106. Beam supported at Both Ends and Loaded with two Concentrated and Unequal Weights at a fixed interval apart, and moving over the Beam.—If A B represent the beam, W_1 and W_2 the two weights, and a = distance between them, then by adopting the same process of reasoning as that given in the last case, it may be shown that when both weights are on the beam the bending moment at any section of the beam is greatest when W_1 is over it, provided that the section is situated between A and F, where $A F = \frac{W_1 l}{W_1 + W_2}$.

When $B F = \frac{W_2 l}{W_1 + W_2}$, the maximum bending moment at any section between F and B will occur when the weight W_2 rests upon it.

1st. Suppose the section to lie between A and F; let x = its distance from A; then when W_1 rests upon it,

$$P = W_1 \frac{l-x}{l} + W_2 \frac{l-x-a}{l} = (W_1 + W_2) \left(\frac{l-x}{l} \right) - \frac{W_2 a}{l}.$$

$$M_x = \frac{x}{l} \{ (W_1 + W_2) (l-x) - W_2 a \}. \quad . \quad . \quad . \quad (10).$$

2nd. Suppose the section to lie between F and B; let x_1 = its distance from A. The maximum bending moment will occur at this section when W_2 rests upon it; in which case

$$Q = \frac{x_1}{l} (W_1 + W_2) - \frac{W_1 a}{l}.$$

$$M_x = \frac{x_1}{l} (W_1 + W_2) (l - x_1) - \frac{W_1 a}{l} (l - x_1). \quad . \quad (11).$$

The loci of the bending moments, as represented by the two equations (10) and (11), are two parabolas, the axes of which are vertical and intersect the beam at two points, one at each side of the centre. At these points the moments are greatest for each half of the beam.

The section where the greatest bending moment occurs in the left half of the beam is situated at a distance to the left of the

$$\text{centre} = \frac{W_2 \alpha}{2(W_1 + W_2)}.$$

The section in the right half, where the bending moment is a maximum, is at a distance from the centre = $\frac{W_1 \alpha}{2(W_1 + W_2)}$

The distances x and x_1 of these points from A are—

$$x = \frac{l}{2} - \frac{W_2 \alpha}{2(W_1 + W_2)} \quad \dots \quad (12).$$

$$\text{And } x_1 = \frac{l}{2} + \frac{W_1 \alpha}{2(W_1 + W_2)} \quad \dots \quad (13).$$

The values of these maximum bending moments may be found from equations (10) and (11) by substituting for x and x_1 the values given in equations (12) and (13).

An expression for the maximum bending at the centre of the beam may be found by putting $x = \frac{l}{2}$ in equations (10) and (11).

We then get—

$$M_{\text{cen.}} = (W_1 + W_2) \frac{l}{4} - \frac{W_2 \alpha}{2} \quad \dots \quad (14),$$

$$\text{or } M_{\text{cen.}} = (W_1 + W_2) \frac{l}{4} - \frac{W_1 \alpha}{2} \quad \dots \quad (15).$$

according as W_1 or W_2 rests on the centre.

In the foregoing investigation the results arrived at are on the assumption that both weights rest on the span. If $W_2 > W_1$, the maximum moment near the end, A, of the beam will occur when W_2 only is on the beam, the other weight resting on the abutment.

Example 6.—A travelling load, concentrated on two wheels 10 feet apart passes over a beam of 40 feet span. If 2 tons rest on the left wheel and 8 tons on the right, find the maximum bending moment at the centre of the beam, and also determine the section on the beam which has the greatest maximum moment, and find its amount.

$$W_1 = 2, \quad W_2 = 8, \quad l = 40, \quad \alpha = 10.$$

The bending moment at the centre will be a maximum when the weight of 8 tons rests on it.

From equation (15) we get—

$$M_{\text{cen.}} = (2 + 8) \times \frac{40}{4} - \frac{2 \times 10}{2} = 90 \text{ foot-tons.}$$

The maximum moment on the whole beam occurs at a section whose distance from the left abutment is found from equation (13),

$$x_1 = \frac{40}{2} + \frac{2 \times 10}{2(2 + 8)} = 21.$$

The section is, therefore, 21 feet from the left bearing, and the amount of the bending moment is found from equation (11) by putting $x_1 = 21$. Thus—

$$M_{21} = \frac{21}{40} \times 10 \times 19 - \frac{2 \times 10 \times 19}{40} = 90.25 \text{ foot-tons.}$$

The maximum bending moments at every 4 feet of the beam, reckoning from the left abutment, are—

$$M_0 = 0, M_4 = 28.8, M_8 = 51.2, M_{12} = 70, M_{16} = 84, M_{20} = 90,$$

$$M_{24} = 88, M_{28} = 78, M_{32} = 60, M_{36} = 34, M_{40} = 0.$$

The values, M_4 and M_{36} , are those produced when only one weight—viz., 8 tons—rests on the beam, the weight of 2 tons resting on the left abutment.

107. Graphic Method of Finding the Position of the Rolling Load so as to produce the Maximum Bending Moment at any Section.—A convenient method of finding by graphic construction what must be the position of the rolling load on the beam, in order that the bending moment at any section may be

a maximum, is the following, which may be made to apply to any number of weights.

Let A B (fig. 59) represent a beam over which passes a rolling load consisting, say, of four weights, W_1, W_2, W_3, W_4 . We wish to determine the position of these loads on the beam so as to produce the maximum bending at any section, say at F.

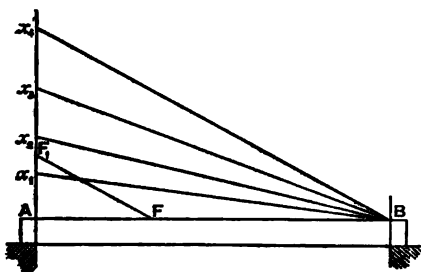

Fig. 59.

Draw a vertical line through A and on it set off

$$A x_1 = W_1, \quad x_1 x_2 = W_2, \quad x_2 x_3 = W_3, \quad x_3 x_4 = W_4.$$

Join $x_1 B$. Through F draw $F F_1$ parallel to $x_1 B$, meeting the vertical line through A at the point F_1 . The maximum moment at F will occur when the weight, represented by the division in which F_1 is situated, rests on F . In the figure F_1 lies in $x_1 x_2$, which represents the weight W_2 . The maximum bending at F will, therefore, occur when the weight W_2 rests upon it.

CHAPTER VIII.

SHEARING FORCES ON BEAMS.

FIXED LOADS.

108. Definition.—*The shearing force at any transverse section of a beam is equal to the algebraic sum of all the external forces acting upon either segment of the beam into which the section divides it.*

We will illustrate this definition by a few simple examples. Suppose AB (fig. 60) to be a beam loaded with a single weight W placed at a distance a from A , then the proportion of W transmitted to the left abutment will be

$$P = W \cdot \frac{l-a}{l}.$$

$W \cdot \frac{l-a}{l}$ will, therefore, represent the shearing force throughout the segment AC .

The shearing stress on the segment $BC = \frac{W a}{l}$.

If W rest on the centre of the beam, the shearing stress will be constant throughout and equal to $\frac{W}{2}$.

Next take the case of a beam loaded with several weights, as is shown in fig. 61.

Let W_1, W_2, W_3, W_4 be the weights resting on the beam; P and Q the supporting forces.

Let the symbol F be used to represent the shearing force, so that

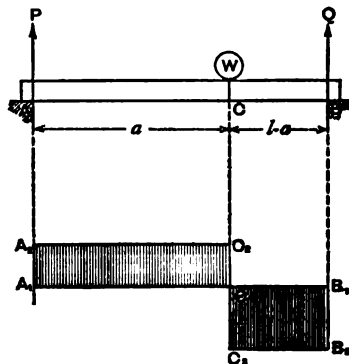

Fig. 60.

F_a = shearing force on the segment a ;
 F_x = shearing force at a section distant x from a fixed point.

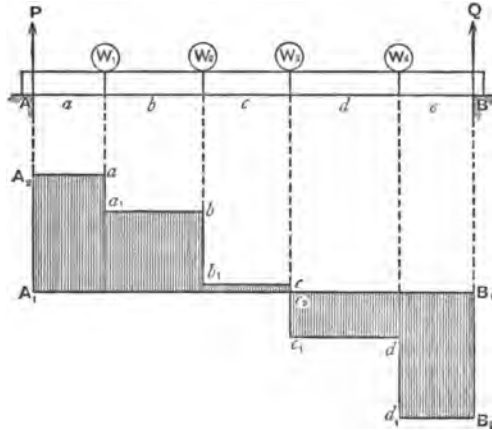

Fig. 61.

From the definition given we have the following :—

$$\begin{aligned} F_a &= P \text{ or } = Q - (W_1 + W_2 + W_3 + W_4), \\ F_b &= P - W_1 \text{ or } = Q - (W_2 + W_3 + W_4), \\ F_c &= P - (W_1 + W_2) \text{ or } = Q - (W_3 + W_4), \\ F_d &= P - (W_1 + W_2 + W_3) \text{ or } = Q - W_4, \\ F_e &= P - (W_1 + W_2 + W_3 + W_4) \text{ or } = Q. \end{aligned}$$

It will be noticed that the shearing force is constant for all sections of the beam between two contiguous weights.

For the sake of convenience, some of the shearing forces may be considered *positive* and some *negative*.

At any section x ; F_x is *positive* when P is greater than the sum of the weights to the left of x , and *negative* when P is less than the sum of these weights.

109. Maximum Shearing Force.—In the case of a beam supported at its extremities, the maximum positive shearing force occurs at the left abutment, and the maximum negative shearing force at the right abutment; the greater of these will be the maximum shearing force for the whole beam.

Graphic Representation of Shearing Forces.—In fig. 60 draw the horizontal line $A_1 B_1$ equal to the span of the beam, and

make $A_1 C_1 = A C$. Draw the vertical line $A_1 A_2$ upwards on a scale of forces = P , and the vertical line $B_1 B_2$ downwards = Q ; the rectangle $A_1 A_2 C_2 C_1$ will represent the diagram of shearing forces for the segment $A C$, and the rectangle $B_1 C_1 C_2 B_2$ will be the diagram for $C B$; the former, being positive, is above the line $A_1 B_1$; and the latter, being negative, is below that line. The shearing force on the segment $A C$ is constant, and is represented by the line $A_1 A_2$; that on $C B$ is also constant, and is represented by the line $B_1 B_2$.

The shearing force diagram of the beam, shown in fig. 61, is given underneath the beam, and the method of its construction is the following:—As before, take the horizontal line $A_1 B_1 = A B$. Draw the vertical $A_1 A_2$ upwards and equal to P . Draw the vertical $B_1 B_2$ downwards and equal to Q . Draw $A_2 a$ horizontally, meeting the vertical through W_1 at a . Measure off $a a_1 = W_1$. Draw $a_1 b$ horizontally, meeting the vertical through W_2 in b . Measure off $b b_1 = W_2$, and so on for the remainder of the diagram. It will be seen that the shearing force changes its sign at W_3 ; to the left of W_3 it is positive and to the right negative. The ordinates of the diagram represent the shearing

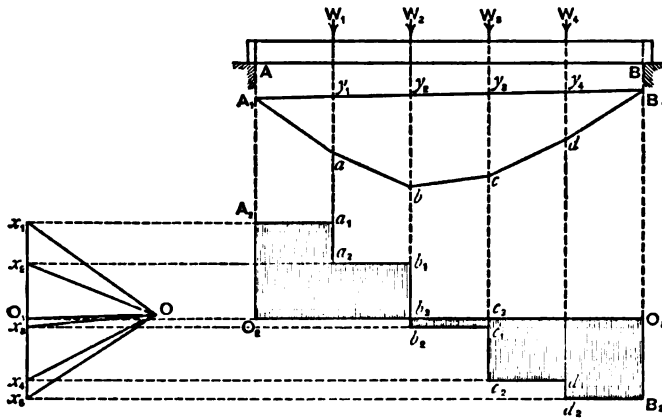

Fig. 62.

stresses at the corresponding sections of the beam. For example, the shearing force between W_2 and W_3 is represented by $c c_2$, and that between W_3 and W_4 by $c_1 c_2$.

110. Purely Graphical Solution.—The solution just given is not a purely graphical one, as it involves algebraic calculations.

The following is a solution of this nature:—In fig. 62 draw the vertical line $x_1 x_2$, and on it set off $x_1 x_3 = W_1$, $x_1 x_4 = W_2$; $x_3 x_4 = W_3$, $x_4 x_5 = W_4$. Choose any pole, O; join O x_1 , O x_2 , &c. Take any point, A, in the vertical line through A, draw $A_1 a$ parallel to O x_1 , meeting the vertical through W_1 at a ; draw $a b$ parallel to O x_2 , and so on as already explained. Join $A_1 B_1$; through O draw $O O_1$, parallel to $A_1 B_1$, then $x_1 O_1 = P$ and $x_2 O_1 = Q$. Through O_1 draw the horizontal line $O_1 O_2 O_3$. This may be considered as a datum line; all parts of the diagram above it representing positive shearing forces, and those below negative shearing forces. Through x_1, x_2 , &c., draw horizontal lines, meeting the vertical lines from the external forces on the beam, and construct the diagram of shearing forces which is represented by the sectioned portion of the diagram.

The figure $A_1 a b c d B_1$ is a graphic representation of the bending moments in the beam.

111. Beam supported at both Ends, and Loaded Uniformly over its Entire Length.—In fig. 63 the beam A B, of span l , is uniformly loaded with w per foot.

Total load on the beam = $w l$.

$$P = Q = \frac{w l}{2}.$$

The shearing force at any section at a distance x from A is

$$F_x = \frac{w l}{2} - w x = w \left(\frac{l}{2} - x \right) \quad . \quad . \quad . \quad (1).$$

F_x is positive when x is less than $\frac{l}{2}$.

F_x is negative when x is greater than $\frac{l}{2}$.

F_x is a maximum when $x = 0$ and when $x = l$.

In the former case, which is at the point A, the shearing stress is positive—

$$F_A = \frac{w l}{2}.$$

In the latter case it is negative—

$$F_B = -\frac{w l}{2}.$$

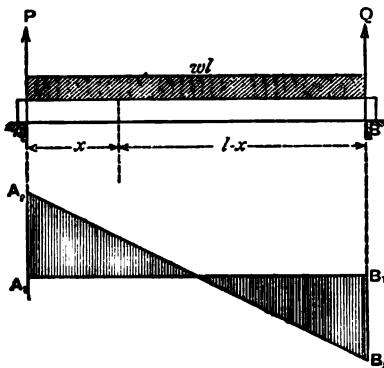

Fig. 63.

F_x becomes a *minimum* when $x = \frac{l}{2}$, or at the centre of the beam, in which case $F_{\text{cen.}} = 0$.

Diagram.—Draw $A_1 A_2$ upwards $= \frac{wl}{2}$, and $B_1 B_2$ downwards $= \frac{wl}{2}$; join $A_2 B_2$, the sectioned figure represents the diagram of shearing forces; the vertical distances between $A_1 B_1$ and $A_2 B_2$ will give the shearing forces at the corresponding points of the span.

Example 1.—A beam, 20 feet span, supports a load of 10 tons at a point 2 feet to the left of the centre. What are the shearing forces on the beam?

$$F_{0 \text{ to } 8} = P = 6 \text{ tons,}$$

$$F_{8 \text{ to } 20} = -Q = -4 \text{ tons.}$$

The shearing forces change from positive to negative at the point of application of the load.

Example 2.—In the example No. 4 given in Chap. VI. determine the shearing forces in the beam.

$$P = 17.4 \text{ tons,} \quad Q = 14.6 \text{ tons.}$$

$$F_{0 \text{ to } 12} = P = 17.4 \text{ tons,}$$

$$F_{12 \text{ to } 24} = P - 7 = 10.4 \text{ tons,}$$

$$F_{24 \text{ to } 36} = P - (7 + 12) = -1.6 \text{ tons,}$$

$$F_{36 \text{ to } 48} = P - (7 + 12 + 10) = -11.6 \text{ tons,}$$

$$F_{48 \text{ to } 60} = P - (7 + 12 + 10 + 3) = -14.6 \text{ tons.}$$

From this it will be observed that the maximum shearing forces occur between the left bearing and the first load, and also that the sign of the forces changes at 24 feet from the left support.

112. Beam Supported at both Ends and Uniformly Loaded over a Portion of the Span.

Let α = length of load,

w = intensity of load per unit of length.

Figs. 64 and 65 represent graphically the shearing stresses on the beam.

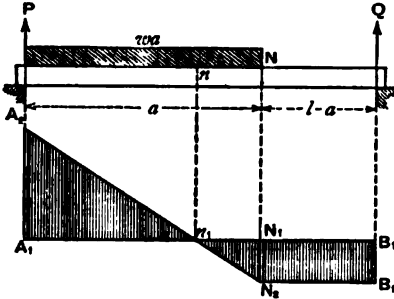

Fig. 64.

In fig. 64 the load commences at the left abutment, and in fig. 65 it occupies an intermediate position on the span.

In both cases there is no shearing force at the section of the beam where the bending moment is a maximum.

In fig. 64 draw the horizontal line $A_1 B_1 =$ span of the beam, and find n , the point where

the bending moment is greatest, as explained in Art. 82.

Draw the vertical $A_1 A_2 = P$ and $B_1 B_2 = Q$.

Through n , the point of maximum bending moment, and N , the extremity of the load, draw the verticals $n n_1$ and $N N_1$, meeting $A_1 B_1$ in n_1 and N_1 . Draw $B_2 N_2$ horizontally, meeting $N N_1$ produced in N_2 ; join $n_1 A_2$, $n_1 N_2$. The shaded figure will represent the diagram of shearing stresses.

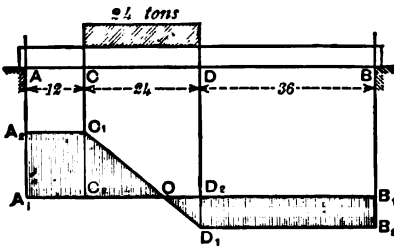

Fig. 65.

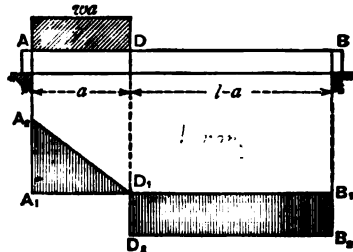

Fig 66.

The diagram in fig. 65 is constructed in a similar manner, so that no description will be necessary.

Fig. 66 represents the diagram when the load does not extend beyond the centre of the beam.

113. Beam Supported at both Ends and Loaded Uniformly over two Segments with Different Intensities of Load.—In fig. 67—Let a and $(l - a)$ represent the lengths of the loads, and w and w_1 the intensities of loads.

Find n , the point of maximum bending moment, as explained in Chap. VI., Art. 84.

Draw $A_1 A_2 = P$, and $B_1 B_2 = Q$, also $M_1 M_2 = P - w a$; join $A_2 M_2$, and $n_1 B_2$; the shaded portion will represent the diagram of shearing stresses in the beam.

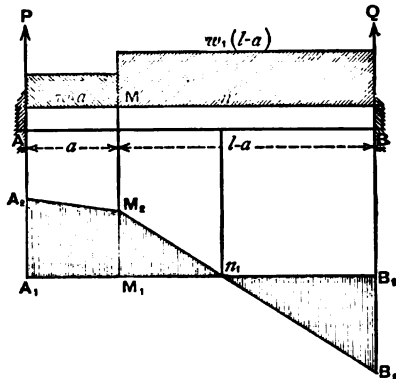

Fig. 67.

114. Cantilever Loaded with One or more Concentrated Weights.—In a cantilever the shearing stress at any section is equal to the sum of the weights between the section and the free end of the cantilever.

In fig. 68 the cantilever, $A B$, is loaded with weights W_1 , W_2 , and W_3 , resting at the points C , D , and B .

The shearing stress on all sections between

$$A \text{ and } C = W_1 + W_2 + W_3$$

$$C \text{ and } D = W_2 + W_3$$

$$D \text{ and } B = W_3$$

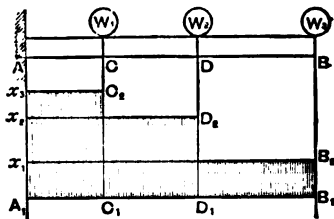

Fig. 68.

Diagram.—The shearing force diagram may be constructed thus:—

Draw the horizontal line $A_1 B_1 = A B$; through the extremity A_1 draw a vertical line $A_1 x_3$; set off on this line, $A_1 x_1 = W_3$, $x_1 x_2 = W_2$, $x_2 x_3 = W_1$.

Through x_1 , x_2 , x_3 draw horizontal lines, meeting the vertical lines through B , D , C in B_2 , D_2 , and C_2 respectively. The shaded figure will represent the shearing stress diagram of the cantilever.

Example 3.—In example 10, Chapter VI.—What are the shearing stresses on the different portions of the cantilever?

$$F_{0 \text{ to } 5} = 8 + 7 + 6 + 5 = 26 \text{ tons,}$$

$$F_{5 \text{ to } 10} = 7 + 6 + 5 = 18 \text{ tons,}$$

$$F_{10 \text{ to } 15} = 6 + 5 = 11 \text{ tons,}$$

$$F_{15 \text{ to } 20} = 5 \text{ tons.}$$

115. Cantilever Uniformly Loaded over its entire Length.—In fig. 69—

Let l = length of cantilever, A B,

w = load per unit of length.

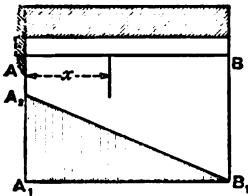

Fig. 69.

The maximum shearing stress occurs at A, and is

$$F_A = w l.$$

At any section at a distance, x , from A—

$$F_x = w(l - x) \quad (2).$$

At the free end of the cantilever, $x = l$, and at this point the shearing stress is zero.

Diagram.—Make $A_1 A_2 = w l$; join $A_2 B_1$; $A_1 A_2 B_1$ will be the diagram of shearing stresses.

Example 4.—A cantilever, 25 feet long, is uniformly loaded with $\frac{1}{2}$ ton per foot. What is the maximum shearing stress on the beam? Find also the shearing stresses at the sections at distances of 10 feet and 20 feet from the fixed end.

$$l = 25, \quad w = \frac{1}{2}, \quad x = 0, 10, \text{ and } 20.$$

From equation (2)—

$$F_{\text{max.}} = w l = 12.5 \text{ tons,}$$

$$F_{10} = w(l - x) = \frac{1}{2}(25 - 10) = 7.5 \text{ tons,}$$

$$F_{20} = \frac{1}{2}(25 - 20) = 2.5 \text{ tons.}$$

116. Cantilever Loaded with a Uniform Weight, and also with Concentrated Weights at Fixed Intervals.—The shearing stress at any section of a cantilever loaded with both a uniformly distri-

buted, and a concentrated load is equal to the sum of the shearing stresses of each load considered separately.

The diagram of shearing stresses is constructed by superposing the diagram in fig. 68 on that in fig. 69.

Example 5.—A semi-girder, 30 feet long, supports three wheels of a locomotive whose distances from the fixed end are 8, 15·5, and 23 feet. If the weights on these wheels be 4, 7, and 3 tons respectively, find the shearing stresses at these points of application; the uniform dead load of the girder being $\frac{3}{4}$ ton per foot.

$$w = \frac{3}{4}, \quad l = 30, \quad W_1 = 4, \quad W_2 = 7, \quad W_3 = 3.$$

$$F_8 = w(l - x) + W_1 + W_2 + W_3 = \frac{3}{4}(30 - 8) + 4 + 7 + 3 = 30\cdot5 \text{ tons,}$$

$$F_{15\cdot5} = \frac{3}{4}(30 - 15\cdot5) + 7 + 3 = 20\cdot875 \text{ tons,}$$

$$F_{23} = \frac{3}{4}(30 - 23) + 3 = 8\cdot25 \text{ tons,}$$

$$F_{\max} = \frac{3}{4} \times 30 + 4 + 7 + 3 = 36\cdot5 \text{ tons.}$$

Example 6.—In example 8 (Chap. VI.), find the shearing stresses at the two ends of the load, and determine, both analytically and graphically, at what point on the beam there is no shearing stress.

$$F_{12} = P = 16 \text{ tons,}$$

$$F_{36} = P - 24 = -8 \text{ tons.}$$

The minimum shearing stress occurs at the section where the bending moment is a maximum, and this section, as has been shown in Chap. VI., is 28 feet from the left abutment.

This may be verified thus :—

Let x = distance of the section where the shearing stress is zero from the left abutment.

We have then

$$F_x = P - (x - 12) = 16 - (x - 12) = 0;$$

$$\text{or, } x = 28 \text{ feet.}$$

Fig. 65, which is drawn to scale, gives a graphic representation of the shearing stresses on the beam. The diagram is constructed thus :—Draw $A_1 A_2 = 16$ tons; $B_1 B_2 = 8$ tons. Draw

$A_2 C_1$, $B_2 D_1$ horizontally, meeting the verticals through the extremities of the load at the points C_1 and D_1 . Join $C_1 D_1$. The point O , where $C_1 D_1$ intersects $A_1 B_1$, gives the point where there is no shearing stress. By scaling we find $A_1 O = 28$ feet. Its position may also be found geometrically thus—from similar triangles $\frac{C_2 O}{D_2 O} = \frac{C_1 C_2}{D_1 D_2}$, from which we find $C_2 O = 16$ feet, or $A_1 O = 28$ feet.

SHEARING STRESSES FOR MOVING LOADS.

117. Beam supported at both Ends and subjected to a Concentrated Load moving in either Direction.—When a concentrated rolling load, W , passes over a beam, the shearing stress at any section of the beam varies with the position of the load.

At a section at a distance, x , from the left abutment, $F_x = P$, and is positive so long as W is to the right of the section. If W be situated to the left of the section $F_x = Q$ and is negative.

P increases as W moves towards the left abutment, and becomes a maximum when W rests directly over the abutment. The maximum positive shearing stress on the beam occurs, therefore, at the left abutment, when W rests at this point, in which case it is equal to W . In the same manner it may be shown that the maximum negative shearing stress occurs at the right abutment when W rests at this point, and is equal to W .

The maximum positive and negative shearing stresses for any section of the beam occur when the weight rests on that section, in which case the positive and negative shearing stresses are P and Q respectively.

Example 7.—A concentrated load of 15 tons rolls across a girder 40 feet span. What are the maximum shearing stresses at intervals of 10 feet?

$$F_0 = F_{40} = 15 \text{ tons,}$$

$$F_{10} = F_{30} = 11.25 \text{ tons,}$$

$$F_{20} = 7.5 \text{ tons.}$$

Example 8.—In the last example determine the maximum shearing stresses if the dead weight of the girder itself be 10 tons uniformly distributed.

$$F_0 = F_{40} = 15 + 5 = 20 \text{ tons,}$$

$$F_{10} = F_{30} = 11.25 + 2.5 = 13.75 \text{ tons,}$$

$$F_{20} = 7.5 \text{ tons.}$$

118. **Beam supported at both Ends and subjected to a Rolling Load, consisting of two or more Concentrated Loads.**—Suppose a beam be acted upon by a system of travelling loads, as is the case where a locomotive passes over a bridge, and let the load be supposed to pass from the right to the left. The shearing stress at any section constantly varies with the position of the load. The shearing force at any section increases as each load in succession approaches it, and when the load passes to the left the shearing force suddenly diminishes by an amount equal to the load. At each section, therefore, the positive shearing stress is a maximum for the time, when each load is immediately to the right of the section, and a minimum when immediately to the left. In order to determine these maximum and minimum values for each weight, let the load system be so placed that this weight rests exactly over the section. Determine the reaction of the left abutment for this arrangement of load, and from it deduct the weights to the left of this particular weight; the result will be the required maximum, and for the minimum further deduct the weight itself.

The following rule is generally true in actual practice:—

When a system of loads roll across a girder, the greatest numerical value of the shearing stress at any section of the girder occurs when the leading load (travelling from the further abutment) arrives at that section.

If the leading load be small in comparison with the others, this rule does not hold.

Example 9.—Three wheels of a locomotive (8 feet centres) pass over a girder 40 feet span. The weights on the leading, driving, and trailing wheels are 5, 8, and 4 tons respectively. What are the maximum shearing stresses on the girder at intervals of 5 feet, the locomotive travelling from right to left?

The greatest shearing stresses at the sections, whose distances from the left abutment are 0, 5, 10, 15, and 20 feet, occur when the leading wheel (5 tons) rests immediately over the section. At the sections distant 25, 30, 35, and 40 feet from the left abutment, the shearing stresses will be a maximum when the trailing wheel (4 tons) rests on them. In the former case the stresses will be positive and equal to the reaction of the left abutment, and in the latter they will be negative and equal to the reaction of the right abutment.

Bearing these points in mind we get the following values for the maximum shearing stresses at the different sections:—

$$F_6 = \frac{5 \times 40 + 8 \times 32 + 4 \times 24}{40} = 13.8 \text{ tons,}$$

$$F_8 = \frac{5 \times 35 + 8 \times 27 + 4 \times 19}{40} = 11.675 \text{ tons,}$$

$$F_{10} = \frac{5 \times 30 + 8 \times 22 + 4 \times 14}{40} = 9.55 \text{ tons,}$$

$$F_{11} = \frac{5 \times 25 + 8 \times 17 + 4 \times 9}{40} = 7.425 \text{ tons,}$$

$$F_{20} = \frac{5 \times 20 + 8 \times 12 + 4 \times 4}{40} = 5.3 \text{ tons,}$$

$$F_{23} = \frac{4 \times 25 + 8 \times 17 + 5 \times 9}{40} = 7.025 \text{ tons,}$$

$$F_{30} = \frac{4 \times 30 + 8 \times 22 + 5 \times 14}{40} = 9.15 \text{ tons,}$$

$$F_{35} = \frac{4 \times 35 + 8 \times 27 + 5 \times 19}{40} = 11.275 \text{ tons,}$$

$$F_{40} = \frac{4 \times 40 + 8 \times 32 + 5 \times 24}{40} = 13.4 \text{ tons.}$$

119. Beam supported at both Ends and subjected to an Advancing Distributed Load of Uniform Intensity.—In fig. 70 suppose an advancing load of w per foot to come on a beam from the right. The maximum positive shearing stress on the section at a distance, x , from the left abutment, occurs when the front of the load is at this section, and the amount of this stress at x , and all points to the left of x , is, $F_x = P = \frac{w(l-x)^2}{2l}$. This shearing stress increases as x diminishes, and becomes a maximum when $x = 0$, or immediately over the left abutment, where it equals $\frac{wl}{2}$.

It is easy to see that the maximum shearing stress at the section indicated must occur when the front of the load is just at it, for if the load move to the right, the value of P will diminish, and consequently the shearing stress. If, on the other hand, the load move to the left of the section the value of P is increased by a *portion* of the load to the left of the section, but the shearing stress is less than the new value of P by the *whole* load to the left of the section, and consequently it is less than the first value of P . This will hold true whether the moving load is long enough to cover the whole span or only a portion of it.

In a similar manner it may be shown that the greatest negative shearing stress occurs at any section when the tail of the load rests over it and that the stress is equal to Q , the supporting force of the right abutment for this position of the load.

It will also be apparent from this that the maximum shearing stress at the centre will occur when the beam is loaded over one-half the span, and will be equal to $\frac{wl}{8}$.

120. Diagram of Shearing Forces when the Length of the Load is equal to, or greater than the Span.—In fig. 70 suppose a load of uniform intensity of w per foot to pass over the beam AB in the direction from B to A . Draw the horizontal line $A_1B_1 = AB$. Draw A_1A_2 vertically at A_1 , and make it = $\frac{wl}{2}$.

Draw the parabolic curve $A_2C_2B_1$; B_1 being the vertex of the parabola. This curve is the locus of the maximum positive shearing stresses at the different sections of the beam. This shearing stress is zero at B , and occurs before any portion of the load enters on the span. The positive shearing stress is a maximum

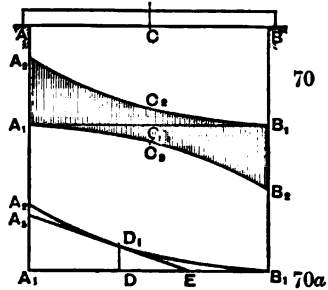

Figs. 70 and 70a.

at A and is represented by $A_1A_2 = \left(\frac{wl}{2}\right)$ and occurs when the span is fully loaded. The maximum shearing stress at the centre is $C_1C_2 = \frac{wl}{8}$, and occurs when the right half of the beam is loaded.

By constructing a similar parabolic curve, $A_1C_3B_2$, underneath A_1B_1 , we get a diagram for the maximum *negative* stresses on the beam, these stresses being exactly the same in value as the positive stresses. The shaded portion of the figure is the diagram for the maximum numerical shearing stresses on the beam during the passage of the load.

121. Diagram of Shearing Forces when the Length of the Load is less than the Span.—The locus of the maximum shearing stresses in this case is not a parabolic curve, but is made up of a straight line and a parabolic curve. It may be drawn thus—

Let a = length of the load,
 w = weight per lineal foot.

Draw the parabolic curve, $A_2 D_1 B_1$, fig. 70a, by making $A_1 A_2 = \frac{wl}{2}$. Set off $B_1 D = a$; draw the vertical, $D D_1$, meeting the curve in D_1 . Through D_1 draw $D_1 A_3$, a tangent to the parabola at D_1 .

A practical method of drawing this tangent is to bisect $D B_1$ at E , join $E D_1$, and produce it. The locus of the positive maximum shearing stresses on the beam is a line composed of the curve $B_1 D_1$, and the straight line $A_3 D_1$.

Example 10.—A railway train weighing 2 tons per foot passes over a bridge 200 feet span. What are the maximum positive and negative shearing stresses on each of the two main girders at intervals of 20 feet, the train being considered as a uniformly distributed load and longer than the span, and the dead weight of the bridge being neglected?

$$l = 200. \quad w = 1 \text{ ton for each girder.}$$

$$\text{Dead load on each girder} = \frac{200 \times 200}{150} \text{ tons.}$$

$$150$$

TABLE XVII.

Distance from Left Abutment	Positive Max. Stress from Live Load.	Negative Max. Stress from Live Load.	Stress from Dead Load.	Total Stress from both Loads.
Feet.	Tons.	Tons.	Tons.	Tons.
0	100	0	75	175
20	81	1	60	141
40	64	4	45	109
60	49	9	30	79
80	36	16	15	51
100	25	25	0	± 25
120	16	36	-15	- 51
140	9	49	-30	- 79
160	4	64	-45	-109
180	1	81	-60	-141
200	0	100	-75	-175

The maximum positive shearing forces may be calculated from the equation, $F_x = \frac{w(l-x)^2}{2l} = P$, and the negative stress from the equation, $F_x = \frac{wx^2}{2l} = Q$, by giving to x its proper value.

It will be seen that the maximum numerical value of the shearing stress occurs at each abutment, and is equal to 100 tons, while the minimum numerical value occurs at the centre of the beam and is equal to 25 tons.

Example 11.—In the last example, what are the maximum shearing stresses at the different sections of the girder during the passage of the load if the dead weight on the girder, including its own weight, be 150 tons equally distributed?

The fourth column in the table gives the shearing stresses arising from the dead weight alone, and the fifth column gives the total maximum shearing arising from both the live and dead loads. These latter stresses are obtained by adding those in column 4 to the corresponding maximum numerical stresses in columns 2 and 3.

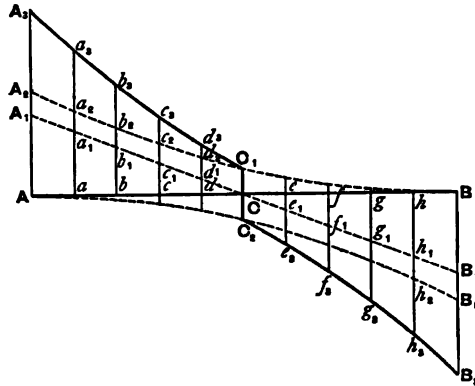

Fig. 71.

It will be seen from Table XVII. that whether the live or dead loads, or a combination of them, be taken, the shearing stresses on both halves of the girder are equal, though of opposite sign.

Fig. 71 represents graphically the shearing stresses on the girder for the different loads drawn to scale.

AB = span = 200 feet.
 Aa = ab = bc, &c. = 20 feet.

Draw the ordinates, $A A_1$ and $B B_1$, each = 75 tons.

Join $A_1 B_1$; the two triangles, $A A_1 C$, $B B_1 C$, will consequently represent the diagram of shearing stresses on the girder for the dead weight alone.

Next, draw the ordinates, $A A_2$, $B B_2$, each equal to 100 tons. Construct the parabolic curves, $A_2 C_1 B$, $B_2 C_2 A$. The spaces included between these curves and $A B$ will give the diagrams for the maximum positive and maximum negative shearing stresses respectively, arising from the travelling load.

Next, by setting off on the ordinates through A , a, b, c , &c., $A_3 A_3 = A A_1$, $a_2 a_2 = a a_1$, $b_2 b_2 = b b_1$, &c., we get the line $A_3 a_3 . . . C_3$, which is the locus of the maximum positive shearing stresses for both loads taken together.

In the same way we can construct $B_3 h_3 g_3 . . . C_3$, which is the locus for the maximum negative shearing stresses.

CHAPTER IX.

CENTRE OF GRAVITY AND MOMENT OF INERTIA OF PLANE SURFACES.

It will be seen in Chapter X. that, in order to determine the transverse strengths of beams of solid section, it will be necessary in the first instance to know the moments of inertia of the sections of such beams with respect to axes passing through their centres of gravity. It is advisable, therefore, that the student be able to determine the centres of gravity and moments of inertia of the sections of such beams as are usually to be met with.

In ordinary language the terms "centre of gravity" and "moment of inertia" have reference to the weight or mass of solid bodies, and belong to the domain of rigid dynamics. As used in this sense they do not concern us here; it is only in their application to plane surfaces that we wish to consider them.

122. Centre of Gravity.—*The centre of gravity of a plane simple surface is its geometrical centre.* That of a circular surface, for example, is the centre of the circle bounding the surface, while that of a parallelogram is the point where its diagonals intersect each other.

The centre of gravity of a triangle is found by joining the middle points of any two sides with the opposite vertices ; the point where the two lines thus drawn intersect each other gives the required centre.

The centre of gravity of the segment A C B of a circle whose centre is O is at the point O_1 where $O O_1 = \frac{(A B)^3}{12 \times \text{area of segment}}$

The line $O O_1$ being drawn to bisect the chord A B.

In the case of a semi-circle the line $O O_1 = .4244 \times \text{radius}$.

The centre of gravity of any four-sided figure may be found thus—

In fig. 72 draw the diagonals A C and B D of the figure A B C D, intersecting each other at E; set off A F = E C; join F D and F B. Find O the centre of gravity of the triangle B F D as explained. This point will be the centre of gravity of the whole figure.

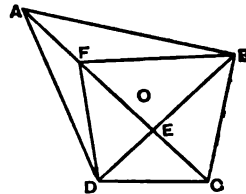

Fig. 72.

123. Centre of Gravity of Section of Flanged Girder.—The following is an important case :—Fig. 73 represents the section of a cast-iron beam which is symmetrical with reference to the vertical axis yy . The section is composed of three rectangles—viz., A B C D and E F G H, which are the sections of the top and bottom flanges respectively, and the rectangle which connects them together, which is the section of the web.

The centre of gravity, O, of the whole section will lie in the line yy , and it will only be necessary to determine its distance along this line from some fixed point.

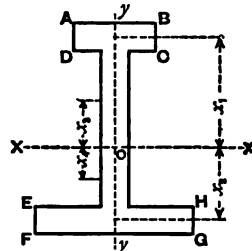

Fig. 73.

Let a_1 = area of top flange A B C D,

a_2 = area of bottom flange E F G H,

a_3 = area of portion of web above X X,

a_4 = area of portion of web below X X,

x_1 = distance of O from centre of gravity of top flange,

Let x_2 = distance of O from centre of gravity of bottom flange,

x_3 = distance of O from centre of gravity of top portion of web,

x_4 = distance of O from centre of gravity of bottom portion of web.

From the principles of the centre of gravity, we get

$$a_1 x_1 + a_3 x_3 = a_2 x_2 + a_4 x_4 \quad . \quad . \quad . \quad (1).$$

As a_1, a_2, a_3, a_4 are known, and as x_2, x_3, x_4 are known in terms of x_1 , from this equation we can determine the value of x_1 , which gives us the position of the centre of gravity, O, from a known point.

Example 1.—Find the position of the centre of gravity of the cross-section of a cast-iron girder of the following dimensions—

Let x = distance of the centre of gravity O from the bottom edge of the section.

Total depth of girder = 14 inches.

Area of top flange = $4 \times 2 = 8$ sq. in.

Area of bottom flange = $6 \times 4 = 24$ „

Area of top portion of web = $2(12 - x)$.

Area of bottom portion of web = $2(x - 4)$.

Distance of O from centre of gravity of—

Top flange = $13 - x$,

Bottom flange = $x - 2$.

Top portion of web = $\frac{12 - x}{2}$.

Bottom portion of web = $\frac{x - 4}{2}$.

We get from equation (1)—

$$8(13 - x) + 2(12 - x) \times \frac{12 - x}{2} = 24(x - 2) + 2(x - 4) \times \frac{x - 4}{2}$$

Or $x = 5.83$ inches.

124. Centre of Gravity of T-Section.—In fig. 74—

Let b = width of flange of tee.

d = total depth.

d_1 = depth of web.

b_1 = thickness of web.

x = distance of centre of gravity of the sections from the top edge.

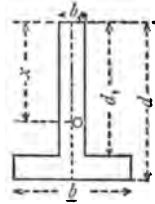

Fig. 74.

By working on the same principle as that employed in the case of the flanged girder, it may be shown that—

$$x = \frac{1}{2} \left\{ d_1 + \frac{bd(d-d_1)}{b_1d_1 + b(d-d_1)} \right\} \quad (2).$$

Example 2.—What is the distance of the centre of gravity of a tee section $6'' \times 3'' \times \frac{1}{2}''$ from the end of the tongue?

$$b = 6, \quad d = 3, \quad d_1 = 2.5, \quad b_1 = .5.$$

From equation (2) we get—

$$x = \frac{2.5}{2} + \frac{.5 \times 6 + .5 \times 3}{6 \times .5 + .5 \times 2.5} = 2.3 \text{ inches.}$$

125. Practical Method of Finding the Centre of Gravity of a Surface.—In the case of figures of irregular form whose centres of gravity cannot be conveniently determined by any of the methods already referred to, the following practical method will fix the centre of gravity sufficiently near for practical purposes:—

Cut a model of the section out of a piece of cardboard or thin metal of uniform thickness, and suspend the model from two different points, as shown in fig. 75, allowing a plumb-bob to hang from the point of suspension in each case. The plumb-line will pass through the centre of gravity in each position, and by tracing the lines on the model their point of intersection O will give the centre of gravity of the figure.

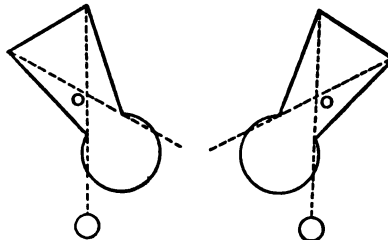

Fig. 75.

Even in cases where the centre of gravity may be found by calculation, this practical method may be adopted with

advantage where great exactness is not required, as it often saves an amount of laborious calculation.

MOMENT OF INERTIA.

126. Definition.—If a plane surface be considered to be composed of a number of infinitesimally thin laminae, and if the area of each lamina be multiplied by the square of its perpendicular distance from a given line or axis, the sum of all these products is called the geometrical moment of inertia of the surface with respect to that axis.

The symbol I is used to express the moment of inertia by most writers on the subject, and we shall adopt the usual notation in the following pages.

127. Moment of Inertia of a Rectangle.—A B C D (fig. 76) is a rectangle; it is required to find its moment of inertia with respect to the axis X X which passes through its centre of gravity, O, and is parallel to the sides A B and D C.

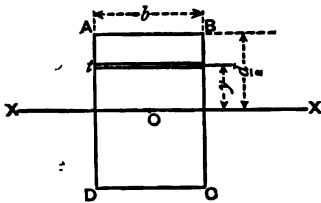

Fig. 76.

Let $AB = b$, $AD = d$.

I = required moment of inertia.

The rectangle may be considered to be made up of a number of elemental areas or laminae parallel to X X.

Let t = thickness of one of these elemental areas,

y = its distance from X X.

Then, its area = $b t$, and its moment of inertia, with respect to X X, from our definition = $b t y^2$.

The moment of inertia of the rectangle = sum of these, or $I = \Sigma b t y^2$.

The expression $\Sigma b t y^2$ is the sum of an infinite series and its value, taking y between its proper limits is $\frac{b d^3}{12}$.*

* This summation is most conveniently effected by means of the integral calculus, thus:— $I = 2 \int_0^{\frac{d}{2}} b y^2 d y = \frac{b d^3}{12}$.

We have, therefore, for the rectangle

$$I = \frac{b d^3}{12} \quad . \quad . \quad . \quad . \quad . \quad (3).$$

If b and d be both expressed in inches, I will be expressed in inch-units.

If $b = d$ we get—

$$I = \frac{d^4}{12} \quad . \quad . \quad . \quad . \quad . \quad (4).$$

which is the expression for the moment of inertia of a square whose side = d , and with respect to an axis passing through its centre of gravity and parallel to a side.

If in the rectangle the axis is parallel to the side d , the expression for the moment of inertia becomes

$$I = \frac{d b^3}{12}.$$

128. Moment of Inertia of Complex Figures.—It will frequently be necessary to determine the moments of inertia of beams of complex sections, made up of two or more simple sections. This can readily be done when the moments of inertia of the simple sections are known, by employing the following important theorem :—

The moment of inertia of an area with respect to any axis is equal to the moment of inertia of the area about a parallel axis passing through its centre of gravity plus the product of the area into the square of the distance between the two axes.

To express this theorem by symbols,

Let I = moment of inertia of a surface about an axis passing through its centre of gravity ;

I_1 = moment of inertia of the same surface about a parallel axis situated at a perpendicular distance, h , from the former ;

A = area of the surface.

Then

$$I_1 = I + A h^2 \quad . \quad . \quad . \quad . \quad . \quad (5).$$

By means of this relationship the moment of inertia (I_1) of the rectangle shown in fig. 76 with respect to an axis passing through the sides AB or DC , may be determined thus—

$$I = \frac{b d^3}{12} \quad h = \frac{d}{2},$$

we get then from equation (5)—

$$I_1 = \frac{b d^3}{12} + b d \times \frac{d^2}{4} = \frac{b d^3}{3}.$$

If the axis passes through the sides A D or B C,

$$I_1 = \frac{db^3}{3}.$$

From this it will be apparent that the moment of inertia of a rectangle, with respect to an axis passing through a side, is *four times* that of the moment of inertia of the same rectangle with respect to a parallel axis passing through its centre of gravity.

Example 3.—A rectangular beam is 4" wide and 6" deep. Determine the moment of inertia of its cross-section,

- 1st. With reference to an axis passing through its centre of gravity and parallel to the short side;
- 2nd. With reference to an axis passing through its centre of gravity and parallel to the long side;
- 3rd. With reference to an axis passing through one of its longer sides;
- 4th. With reference to an axis parallel to a short side and at a perpendicular distance of 2" from it.

$$1st. I = \frac{4(6)^3}{12} = 72 \text{ inch-units};$$

$$2nd. I = \frac{6(4)^3}{12} = 32 \text{ inch-units};$$

$$3rd. I = 32 + 24(2)^2 = 128 \text{ inch-units};$$

$$4th. I = 72 + 24(1)^2 = 96 \text{ inch-units}.$$

129. Moment of Inertia of a Circular Disc.—In fig. 77,

Let I_1 = moment of inertia of the disc with reference to an axis passing through its centre O and perpendicular to its plane;

I = moment of inertia with reference to an axis A B passing through its centre and lying in its plane.

The circular surface may be considered to be made up of a number of circular laminae.

Let t = thickness of one of these whose distance from O = y .

The moment of inertia of such a lamina with reference to an axis perpendicular to the plane of the paper

= $2\pi y^3 t$, and the moment of inertia of the whole surface is

$$I_1 = \Sigma 2\pi y^3 t.$$



Fig. 77.

If R = radius of circle

$$I_1 = \frac{\pi R^4}{2}.*$$

Again,

$$I = \frac{I_1}{2} = \frac{\pi R^4}{4} \quad . \quad . \quad . \quad (6).$$

130. Moments of Inertia of a Circular Ring and Hollow Rectangle.
 —When a surface is obtained by adding two other surfaces together, or by deducting one surface from another, both of which have a common centre of gravity, the value of the moment of inertia of the original surface is obtained by adding or subtracting the moment of inertia of one of the constituent surfaces to or from the other.

Take, for example, the case of a circular ring, as shown in fig. 78. If r and r_1 be the radii of the outer and inner circles respectively, and I_1, I_2, I be the moments of inertia of the large and small circular surfaces and the ring respectively, with reference to a diameter as axis, we have—

$$I_1 = \frac{\pi r^4}{4},$$

$$I_2 = \frac{\pi r_1^4}{4}.$$

$$I = I_1 - I_2 = \frac{\pi}{4} (r^4 - r_1^4) \quad . \quad . \quad . \quad (7).$$

In the same manner consider the case of the hollow rectangle, shown in fig. 79,



Fig. 78.

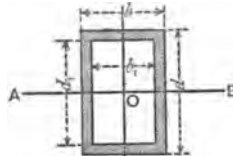

Fig. 79.

where O is the common centre of gravity of both rectangles. The moment of inertia of the large rectangle with reference to the axis $AB = \frac{b d^3}{12}$.

$$* I_1 = 2 \pi \int_0^R y^3 dy = \frac{\pi R^4}{2}.$$

That of the small rectangle with reference to the same axis
 $= \frac{b_1 d_1^3}{12}$.

The moment of inertia of their difference or the portion shown
 in section

$$= \frac{1}{12} (b d^3 - b_1 d_1^3) (8).$$

Example 4.—What is the moment of inertia of the section of
 a circular tube of which the external and internal radii are
 12" and 10" respectively?

- (1) With reference to a diameter of the section;
- (2) With reference to the axis of the tube.

$$r = 12; \quad r_1 = 10.$$

- (1) From equation (7)—

$$I_{diam.} = \frac{\pi}{4} \{(12)^4 - (10)^4\} = 8,432 \text{ inch-units};$$

- (2) $I_{axis} = 2 I_{diam.} = 16,864 \text{ inch-units}.$

Example 5.—In the last example find the moment of inertia
 of the tube with respect to a tangent to its outside surface and
 parallel to a diameter.

From equation (5)—

$$I_{tan.} = I_{diam.} + \pi (r^2 - r_1^2) \times r^2;$$

$$I_{tan.} = 8,432 + 19,905 = 28,337 \text{ inch-units}.$$

Example 6.—What is the moment of inertia of the cross-section
 of a hollow rectangular tube 6" × 4" outside dimensions, and of
 a uniform thickness of 1.5 inches, with reference to axes passing
 through its centre of gravity and parallel to its longer and
 shorter sides?

Let I_1 = moment of inertia with respect to axis parallel to
 longer side;

I_2 = moment of inertia with respect to axis parallel to
 shorter side.

From equation (8), we obtain—

$$I_1 = \frac{6 \times (4)^3 - 3 \times (1)^3}{12} = 31.75 \text{ inch-units};$$

$$I_2 = \frac{4 \times (6)^3 - 1 \times (3)^3}{12} = 69.75 \text{ inch-units}.$$

131. Moment of Inertia of Beams of H-Section with Equal Flanges.—Fig 80 represents the section of a beam where

d = total depth,

d_1 = depth of web,

b = width of each flange,

$\frac{d-d_1}{2}$ = thickness of each flange,

b_1 = thickness of web.

The moments of inertia of the section with respect to axes $X X$ and $Y Y$ passing through its centre gravity, are equal to the difference of the moments of inertia with respect to those axes of the two rectangles whose areas are $b d$ and $(b - b_1) d_1$.

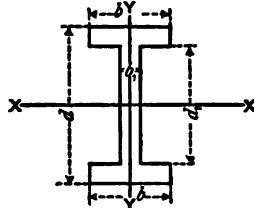

Fig. 80.

$$I_{XX} = \frac{1}{12} \{ b d^3 - (b - b_1) d_1^3 \} \quad (9).$$

$$I_{YY} = \frac{1}{12} \{ d b^3 - d_1 (b^3 - b_1^3) \} \quad (10).$$

If the web be thin in proportion to the other dimensions, its moment of inertia may be neglected without introducing much error; in such case, putting $b_1 = 0$, we obtain—

$$I_{XX} = \frac{1}{12} b (d^3 - d_1^3) (11).$$

$$I_{YY} = \frac{1}{12} b^3 (d - d_1) (12).$$

Example 7.—Find the moments of inertia of the cross-section of a 12" × 6" rolled girder, with reference to a horizontal axis ($X X$) and also with reference to a vertical axis ($Y Y$), both passing through its centre of gravity, the thickness of the flanges being 1", and that of the web $\frac{1}{2}$ ".

$$b = 6, \quad d = 12, \quad b_1 = .5, \quad d_1 = 10.$$

Substituting these values in equations (9) and (10), we get—

$$I_{XX} = \frac{1}{12} \{ 6 \times (12)^3 - (6 - .5) \times (10)^3 \} = 405.6 \text{ inch-units.}$$

$$I_{YY} = \frac{1}{12} [12 \times (6)^3 - 10 \{ (6)^3 - (.5)^3 \}] = 36 \frac{1}{2} \text{ inch-units.}$$

Example 8.—In the last example what are the moments of inertia of the section if the web be neglected?

From equations (11) and (12) we get—

$$I_{xx} = \frac{1}{12} \times 6 \{(12)^3 - (10)^3\} = 364 \text{ inch-units.}$$

$$I_{yy} = \frac{1}{12} \times (6)^3 \times 2 = 36 \text{ inch-units.}$$

It will be observed that the amount of error in the moment of inertia, by neglecting the web, is almost nil, when taken with respect to the axis Y Y.

In calculating the moments of inertia of beams of H-section of equal flanges, if the thickness of the flanges be small compared with the depth of the beam, the flanges may be supposed to be concentrated on their centre lines, without introducing much error into the result.

Let d_0 = depth between the centres of the flanges,

a_1 = area of each flange,

a_2 = area of web.

Then, from the definition of the moment of inertia, we get approximately—

$$I = a_1 \left(\frac{d_0}{2}\right)^2 + a_1 \left(\frac{d_0}{2}\right)^2 + \frac{1}{12} a_2 d_0^2.$$

$$I = \frac{d_0^2}{2} \left(a_1 + \frac{a_2}{6}\right) \dots \dots \dots (13).$$

where I is taken with reference to an axis passing through the centre of gravity of the section and parallel to the flanges. If the web of the girder be thin, and we neglect its moment of inertia, equation (13) becomes

$$I = \frac{d_0^2}{2} a_1 \dots \dots \dots (14).$$

Example 9.—Apply equations (13) and (14) to determine the moment of inertia of the section of the beam given in example 7, and show the amount of error introduced.

$$d_0 = 11, \quad a_1 = 6, \quad a_2 = 5.$$

From equation (13) we get—

$$I = \frac{(11)^2}{2} \left(6 + \frac{5}{6}\right) = 413.4 \text{ inch-units.}$$

As the correct value of the moment of inertia = 405.6 inch-units, the error = 413.4 - 405.6 = 7.8 inch-units, or nearly 2 per cent. in excess, which is a trivial discrepancy.

Neglecting the web and applying equation (14) we get—

$$I = \frac{(11)^2}{2} \times 6 = 363 \text{ inch-units.}$$

The error in this case = 405.6 - 363 = 42.6 inch-units, or about 10½ per cent. less than the true value.

In Chapter X. it will be seen that the transverse strength of a beam depends upon the moment of inertia of its section, and we may lay it down as a general practical rule for H-beams with equal flanges—

1st. That when the flanges and web are thick, as is usually the case with cast-iron girders, the value of I should be calculated from equation (9).

2nd. When the flanges are comparatively thin, as is the case with wrought-iron or steel-rolled girders (except those of small section), it will be sufficiently accurate to determine I from equation (13).

3rd. When both flanges and web are thin, as happens in wrought-iron or steel-built or rivetted girders, I may be calculated from equation (14).

Example 10.—Determine the moment of inertia of the section of a cast-iron girder of the following dimensions, with respect to an axis passing through its centre of gravity and parallel to the flanges:—

The total depth of girder = 18".

Area of top flange = 6" × 2" = 12 square inches,

Area of bottom flange = 12" × 3" = 36 square inches,

Area of web = 13" × 2" = 26 square inches,

Total area of section = 74 square inches.

To effect this solution we must first determine the position of the centre of gravity of the section.

Let x = distance of the centre of gravity from the outside edge of the bottom flange;

we have, therefore,

$$12(17-x) + 2(16-x) \times \frac{16-x}{2} = 36\left(x - \frac{3}{2}\right) + 2(x-3) \times \frac{x-3}{2}.$$

Reducing this equation, we get, $x = 6.8$ inches.

To find the moment of inertia of the section, we must substitute in equation (g), p. 150, the proper values of the symbols, viz :—

$$b = 6, \quad b_1 = 12, \quad t = 2, \quad t_1 = 3, \quad d = 11.2, \quad d_1 = 6.8, \quad t_2 = 2.$$

$$I = \frac{1}{3} \{ 6(11.2)^3 - (6-2)(11.2-2)^3 + 12(6.8)^3 - (12-2)(6.8-3)^3 \} \\ = 2,846 \text{ inch-units.}$$

Example 11.—In the last example, determine the moment of inertia of the section with respect to a vertical axis passing through the centre of gravity of the section.

$$I_1 = \text{moment of inertia of top flange} = \frac{2(6)^3}{12} = 36,$$

$$I_2 = \text{,, ,, bottom ,,} = \frac{3(12)^3}{12} = 432,$$

$$I_3 = \text{,, ,, web ,,} = \frac{13(2)^3}{12} = 8.66,$$

$$I = \text{,, ,, the whole section}$$

$$= I_1 + I_2 + I_3 = 36 + 432 + 8.66 = 476.66 \text{ inch-units.}$$

Example 12.—Determine the moment of inertia of the section of the girder, given in example 10, with respect to a horizontal axis passing through its bottom edge.

From Art. 128 we find—

$$I_1 = \text{moment of inertia of top flange} = \frac{6(2)^3}{12} + 6 \times 2(17)^2 \\ = 3,472 \text{ inch-units,}$$

$$I_2 = \text{,, ,, bottom ,,} = \frac{12(3)^3}{12} + 12 \times 3(1.5)^2 \\ = 108 \text{ inch-units,}$$

$$I_3 = \text{,, ,, web ,,} = \frac{2(13)^3}{12} + 13 \times 2(9.5)^2 \\ = 2,712.7 \text{ inch-units,}$$

$$I = \text{required moment of inertia} = I_1 + I_2 + I_3 = 6,292.7 \text{ ,,}$$

132. Moments of Inertia of Beams of Various Sections about a Horizontal Axis passing through their Centres of Gravity.

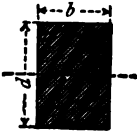

Beam of Solid Rectangular Section.

$$I = \frac{b d^3}{12} \quad . \quad . \quad . \quad (a).$$

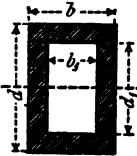

Beam of Hollow Rectangular Section.

$$I = \frac{b d^3 - b_1 d_1^3}{12} \quad . \quad . \quad (b)$$

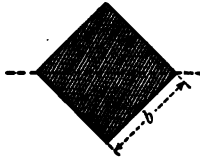
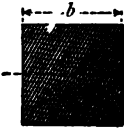

Beam of Solid Square Section.

$$I = \frac{b^4}{12} \quad . \quad (c).$$

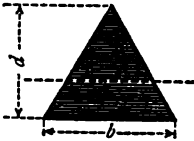

Beam of Solid Triangular Section.

$$I = \frac{b d^3}{36} \quad . \quad . \quad (d).$$

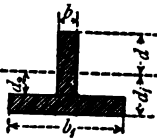

Beam of T-Section.

$$I = \frac{1}{3} \{b d^3 + b_1 d_1^3 - (b_1 - b) d_2^3\} \quad (e).$$

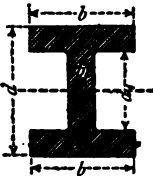

Beam of H-Section with Equal Flanges.

$$I = \frac{1}{12} \{b d^3 - (b - b_1) d_1^3\} \quad . \quad (f).$$

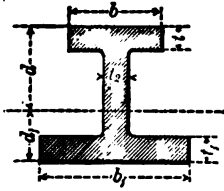
*Beam of H-Section with Unequal Flanges.*

$$I = \frac{1}{3} \left\{ b d^3 - (b - t_2) (d - t)^3 + b_1 d_1^3 - (b_1 - t_2) (d_1 - t_1)^3 \right\} \quad (g).$$

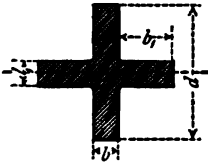
*Beam of Cruciform Section.*

$$I = \frac{1}{12} \{ b d^3 + 2 b_1 d_1^3 \} \quad (h).$$

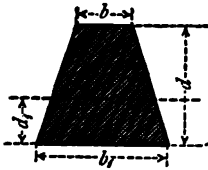
*Beam of Trapezoidal Section.*

$$I = d^3 \frac{b_1^2 + 4 b b_1 + b^2}{36(b_1 + b)} \quad (i).$$

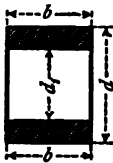
*Beam of H-Section of Equal Flanges, the Web being neglected.*

$$I = \frac{1}{12} b (d^3 - d_1^3) \quad (j).$$

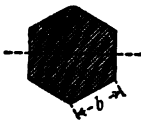
*Beam of Hexagonal Section.*

$$I = \frac{5419}{3} b^4 \quad (k).$$

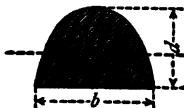
*Beam of Parabolic Section.*

$$I = \frac{b d^3}{21.875} \quad (l).$$

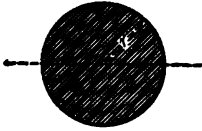

Beam of Solid Circular Section.

$$I = .7854 r^4 . . . (m).$$

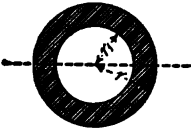

Beam of a Hollow Circular Section.

$$I = .7854 (r^4 - r_1^4) . . . (n).$$



Beam of a Solid Semicircular Section.

$$I = .11 r^4 . . . (o).$$

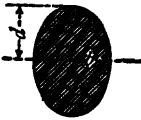

Beam of a Solid Elliptical Section.

$$I = .7854 b d^3 . . . (p).$$

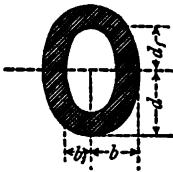

Beam of a Hollow Elliptical Section.

$$I = .7854 (b d^3 - b_1 d_1^3) . . . (q).$$

CHAPTER X.

INTERNAL STRESSES IN BEAMS.

133. **Theory of the Stresses on Loaded Beams.**—The following investigation, it must be borne in mind, is mainly a theoretical one, and certain assumptions are made which are not altogether warranted from a practical stand-point.

It is not surprising, therefore, that the results deduced do not

in all cases accord with those derived from actual experiment. But, however imperfect the theory may be, it is the best which we possess, and the results deducible from it, when modified by practical experience, are sufficiently accurate for all ordinary purposes.

Fig. 81 represents a portion of a loaded beam, the section of which is rectangular; the investigation will apply, however, to any beam whose section is symmetrical with reference to a vertical axis, and it is assumed—though the assumption is not accurate for most materials—that the material of which it is composed is a *perfectly elastic* one.

YY is a vertical section passing through the centre of the beam; MN, MN are sections at any other parts; the lines MN, MN, YY all radiate towards the common centre of the circle of curvature of the layers MM, OO, NN, &c.

Before bending, the lines MN, MN were vertical, and the layers MM, NN were of the same length. After bending, the

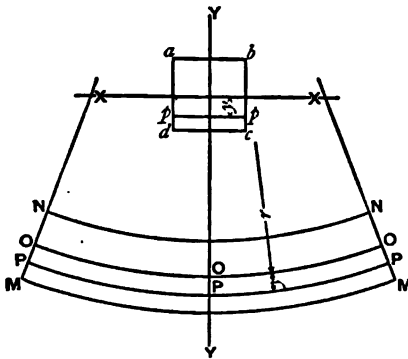

Fig. 81.

top layer NN becomes shortened and the bottom MM lengthened, and there will be a certain layer OO intermediate between these which is neither lengthened nor shortened, but retains its original length. This latter layer which in a beam of rectangular section, or any section symmetrical with respect to a horizontal axis, is in the centre of the beam, and is called the neutral surface of the beam.

All layers of the beam below OO will be lengthened, and will, therefore, be exposed to a tensile stress, while all those above OO will be shortened and exposed to a compressive stress; the layer OO which is not altered in length will be exposed to no stress whatever.

Consider any intermediate layer, PP, whose distance below the neutral surface is equal to y . Then if r = radius of curvature of the neutral surface OO, $r + y$ will be the radius of the layer PP.

The original length of PP was equal to OO, so that PP - OO

represents its increase of length; and as the strain on any layer is measured by its increase of length, the strain on P P per unit of length is represented by its increase of length per unit of length.

If l = this strain we get—

$$l = \frac{PP - OO}{OO}.$$

As the lengths of arcs of circles are proportional to their chords, we get by similar triangles—

$$\frac{PP}{OO} = \frac{r+y}{r} \quad \therefore l = \frac{r+y}{r} - 1 = \frac{y}{r}.$$

From this it is seen that *the strain, and consequently the stress, on any layer of a perfectly elastic beam is proportional to its distance from the neutral surface.*

This is practically true of beams of all materials, so long as the material is not strained beyond a limit considered safe in practice.

The layer at a distance y above the neutral surface is shortened by the same amount as the layer P P is lengthened, consequently the stress upon it is the same in amount, but of opposite kind.

As the total stresses above and below the neutral surface are equal in amount, it follows that the neutral surface must pass through the centres of gravity of the different sections of the beam, and the neutral axis X X must pass through the centre of gravity of its cross-section.

It will be gathered from the foregoing explanation, that in a loaded beam of any section the external fibres at the top or bottom may be strained to their breaking point, while those near the neutral surface may be exposed to little or no stress. Beams of a rectangular section which have a great deal of material close to the neutral surface are, therefore, not economical, while those of a circular section are still less so. On the other hand, flanged beams of H-section, which have the bulk of the material at a distance from the neutral surface, are best adapted for resisting the longitudinal stresses of compression and tension.

The bending moment developed in each section of a beam has to be resisted and held in equilibrium by its *moment of resistance* with reference to the neutral axis, so that in all cases the bending moment must be equal to this moment of resistance.

Let μ = moment of resistance to flexure.

M = bending moment.

Then in all cases $\mu = M$.

The expression μ , in addition to being called *the moment of resistance to flexure*, is also sometimes designated *the moment of the elastic forces*, or *the moment of stress*.

134. We will now show how μ may be determined for beams of different sections.

Consider the cross-section, $abcd$, of the beam, shown in fig. 81, to be made up of an infinite number of elementary laminae parallel to the neutral axis X X.

Let t = thickness of one of these laminae pp .

b = breadth " " "

y = its distance from X X.

f = intensity of stress per unit on the lamina.

Then the total stress on the lamina = $f b t$.

The moment of this stress with respect to the neutral axis

$$= f b t y \quad \dots \quad (1).$$

Let h_1 = distance of the extreme fibres at ab from X X.

h_2 = " " " dc "

f_1 = compressive unit-stress on the fibres ab .

f_2 = tensile " " " cd .

Then we have $\frac{f}{f_1} = \frac{y}{h_1}$, or $f = \frac{f_1}{h_1} \cdot y$.

Similarly we get $f = \frac{f_2}{h_2} \cdot y$.

Substituting these values in equation (1) we get moment of stress on the elementary lamina pp

$$= \frac{f_1}{h_1} b t y^2 = \frac{f_2}{h_2} b t y^2.$$

Taking the sum of all these moments about the neutral axis, we obtain the moment of resistance of the whole section.

$$\mu = \frac{f_1}{h_1} \Sigma b t y^2, \text{ or } \mu = \frac{f_2}{h_2} \Sigma b t y^2.$$

We have seen in Chapter IX., Art. 126, that the expression $\Sigma b t y^2$ represents the moment of inertia of the section with respect to the axis X X or $\Sigma b t y^2 = I$.

$$\text{Consequently } \mu = \frac{f_1}{h_1} \cdot I, \text{ or } \mu = \frac{f_2}{h_2} \cdot I.$$

Of these two values of μ the least should be taken in calculating the strength of the beam.

The general expression for the moment of resistance of the section is—

$$\mu = \frac{f}{h} \cdot I \quad . \quad . \quad . \quad . \quad . \quad (2),$$

where f = unit-stress on the fibres at the distance h from the neutral axis.

As $\mu = M$ (bending moment) we get—

$$M = \frac{f}{h} \cdot I \quad . \quad . \quad . \quad . \quad . \quad (3).$$

This equation will enable us to determine the strength of any beam, no matter how loaded.

If the bending moment at any section of a beam be known, and also the moment of inertia of the section about its neutral axis, the intensity of the stress on the fibres at a distance h from the neutral axis may be found from the equation—

$$f = \frac{M h}{I} \quad . \quad . \quad . \quad . \quad . \quad (4),$$

which is derived from equation (3).

135. Beam of Solid Rectangular Section.—

Let b = breadth of beam.
 d = depth ,,

In this case the neutral axis passes through the centre of the section so that—

$$h = \frac{d}{2}, \quad I = \frac{b d^3}{12}.$$

Substituting these values in equation (3) we get—

$$M = \frac{f b d^2}{6} \quad . \quad . \quad . \quad . \quad . \quad (5).$$

If the section of the beam be a square, whose side is b , we get—

$$M = \frac{f b^3}{6} \quad . \quad . \quad . \quad . \quad . \quad (6).$$

136. Beam of a Solid Square Section, One Diagonal being Vertical—

Let b = side of square.

$$\text{Then } h = \frac{b}{\sqrt{2}}.$$

$$\text{And since } I = \frac{b^4}{12}.$$

Substituting in equation (3) we get—

$$M = \frac{f \sqrt{2}}{b} \times \frac{b^4}{12} = \frac{f b^3}{8.5} \quad . \quad . \quad . \quad (7).$$

$$\therefore M = \frac{f b^3}{8.5}$$

137. Beam of a Solid Circular Section.—

Let r = radius, $h = r$.

$$I = .7854 r^4,$$

$$M = .7854 f r^3 \quad . \quad . \quad . \quad . \quad (8).$$

138. Beam of a Hollow Circular Section.—

Let r = external radius,

r_1 = internal radius,

$$I = .7854 (r^4 - r_1^4),$$

$$M = .7854 f \cdot \frac{r^4 - r_1^4}{r} \quad . \quad . \quad . \quad (9).$$

If t = thickness of the tube, then $r_1 = r - t$.

Substituting this value of r_1 in equation (9), we obtain—

$$\begin{aligned} M &= .7854 f \cdot \frac{r^4 - (r - t)^4}{r} \\ &= .7854 f \cdot \frac{4 r^3 t - 6 r^2 t^2 + 4 r t^3 - t^4}{r}. \end{aligned}$$

If t be small compared with r , the expressions containing

t^2 , t^3 , and t^4 may be neglected without introducing much error, and we get—

$$M = .7854 f \cdot \frac{4 r^3 t}{r} = \pi f r^2 t . \quad (10).$$

139. Beam of Hollow Rectangular Section.—

Let d and d_1 = external and internal depths,

b and b_1 = external and internal breadths.

$$I = \frac{b d^3 - b_1 d_1^3}{12},$$

$$M = \frac{f}{6 d} (b d^3 - b_1 d_1^3) . \quad (11).$$

If the beam be of a hollow square section

$$b = d, \quad b_1 = d_1.$$

$$M = \frac{f}{6 d} (d^4 - d_1^4) . \quad (12).$$

If the square tube be of uniform thickness, t , throughout $d_1 = d - 2 t$.

Substituting this value of d_1 in equation (12) and neglecting all terms containing t^2 , t^3 , and t^4 , we get—

$$M = \frac{4}{3} \cdot f d^2 t . \quad (12a).$$

This equation gives a sufficiently accurate result if t be small compared with d .

140. Beams of H-Section with Equal Flanges.—

Let b = width of each flange,

d = total depth of beam,

d_1 = depth of web,

b_1 = thickness of web.

$$\text{Then } I = \frac{1}{12} \{b d^3 - (b - b_1) d_1^3\}$$

$$h = \frac{d}{2}.$$

Substituting these values of I and h in equation (3), we get—

$$M = \frac{f}{6d} \{b d^3 - (b - b_1) d_1^3\} \quad . \quad . \quad (13).$$

If the thickness of the flanges be small compared with the depth of the beam, we obtain from equation (13), Chapter IX.—

$$M = f d_0 \left(a_1 + \frac{a_2}{6} \right) \quad . \quad . \quad (14),$$

where d_0 = depth between centres of flanges,

a_1 = area of each flange,

a_2 = area of the web.

If the web of the girder be thin, it may be neglected without introducing much error; in which case we find from equation (14), Chapter IX.—

$$M = f d_0 a_1 \quad . \quad . \quad . \quad (15).$$

If the beam be placed so that its web is horizontal instead of vertical; its moment of inertia, with respect to a horizontal axis passing through its centre of gravity, is from equation (10), Chapter IX.—

$$I = \frac{1}{12} \{b^3 (d - d_1) + b_1^3 d_1\},$$

where b, d, b_1, d_1 , represent the dimensions already given. From this we get—

$$M = \frac{f}{6} \left\{ b^2 (d - d_1) + \frac{b_1^3 d_1}{b} \right\} \quad . \quad . \quad (16).$$

An adaptation of equation (15) may be used for determining the strengths of most wrought-iron and steel-riveted girders, as in such cases the webs are thin, and for practical purposes the strength which they add to the girder in resisting bending moments may be neglected. In such girders, also, the thickness of the flanges is small compared with the depth of the girder.

Let S = total stress on either flange of the girder in tons;

then $S = f a_1$,

where f = unit-stress in either flange,

a_1 = sectional area of either flange in square inches.

Equation (15) may, therefore, be written

$$M = S \times d \quad . \quad . \quad . \quad (17),$$

where d = depth between centres of gravity of the flanges.

For girders resting on two abutments of span l and supporting a weight W at the centre, $M = \frac{Wl}{4}$.

Substituting in equation (17), we get—

$$S = \frac{Wl}{4d} \quad . \quad . \quad . \quad (18).$$

For girders supporting a distributed load W ,

$$S = \frac{Wl}{8d} \quad . \quad . \quad . \quad (19).$$

For a cantilever of length, l , with a weight, W , at the end,

$$S = \frac{Wl}{2d} \quad . \quad . \quad . \quad (20).$$

For a cantilever supporting a distributed weight, W ,

$$S = \frac{Wl}{d} \quad . \quad . \quad . \quad (21).$$

Example 1.—A cast-iron girder of H-section rests on two supports 20 feet apart; what weight placed at its centre will break it, the modulus of rupture being 12 tons; and the section of the girder being—

Total depth $d = 12$ inches,
 Depth of web $d_1 = 9$ inches,
 Width of each flange $b = 5$ inches,
 Thickness of web $b_1 = 1$ inch ?

The flanges are of equal thickness, viz., $1\frac{1}{2}$ inches,

$$f = 12 \text{ tons}, \quad l = 240 \text{ inches.}$$

Let $W =$ required breaking weight in tons.
 The maximum bending moment, $M = 60 W$.
 Substitute in equation (13)

$$\begin{aligned} 60 W &= \frac{f}{6d} \{b d^3 - (b - b_1) d_1^3\} \\ &= \frac{12}{6 \times 12} \{5 \times (12)^3 - (5 - 1) \times (9)^3\}. \end{aligned}$$

$$W = 15.9 \text{ tons.}$$

Applying the approximate equation (14), we get—

$$60 W = 12 \times 10 \cdot 5 \left(7 \cdot 5 + \frac{9}{6} \right).$$

or, $W = 18 \cdot 9$ tons.

141. Beams of H-Section with Unequal Flanges.—In cast-iron girders of H-section, the section of the bottom flange is made considerably larger than that of the top, as cast iron is much stronger in compression than in tension.

The moment of resistance of the section of such a girder is expressed by the general equation

$$\mu = \frac{f}{h} \cdot I,$$

where I = moment of inertia of the section with respect to an axis passing through its centre of gravity, and parallel to the flanges.

f = unit-stress on the extreme fibres of the beam,

h = distance of extreme fibres from the neutral axis.

f may represent the unit-stress on the extreme fibres either at the top or bottom of the beam, whichever gives to $\frac{f}{h}$ its least value.

For example, if the ultimate strength of cast iron in compression = 40 tons per square inch, and the distance of the extreme top fibres from the neutral axis = 8 inches, then

$$\frac{f}{h} = \frac{40}{8} = 5.$$

In the same beam, if the strength of the iron in tension = 8 tons per square inch, and the distance of the extreme bottom fibres from the neutral axis = 2 inches, then $\frac{f}{h} = \frac{8}{2} = 4$.

As this second value of $\frac{f}{h}$ is the smaller, it must be substituted in the general equation in determining the strength of the beam.

Let b = width of top flange,
 t = thickness of top flange,
 b_1 = width of bottom flange,
 t_1 = thickness of bottom flange,
 t_2 = thickness of web,
 d = distance of top of beam from the neutral axis,
 d_1 = " " bottom " "
 f and f_1 = unit-stresses at the top and bottom of the beam,

$$I = \frac{1}{3} \{ b d^3 - (b - t_2) (d - t)^3 + b_1 d_1^3 - (b_1 - t_2) (d_1 - t_1)^3 \}.$$

See equation (g), page 150.

Substituting this value of I in equation (2) we obtain—

$$\mu = \frac{f_1}{3 d_1} \{ b d^3 - (b - t_2) (d - t)^3 + b_1 d_1^3 - (b_1 - t_2) (d_1 - t_1)^3 \} \quad (22).$$

$$\frac{f_1}{3 d_1} \text{ must be used in this case as } \frac{f_1}{3 d_1} < \frac{f}{3 d}.$$

This is the complete expression for the moment of resistance of the section. Several approximations may be made according to the relative proportions of the different parts of the section. For example, if the thickness of the flanges be small compared with the depth of the beam, they may be supposed to be concentrated at their centre lines. In such case we get the following approximate formula—

$$\mu = \frac{f}{d} \left\{ \left(\alpha_1 + \frac{\alpha_3}{3} \right) d^2 + \left(\alpha_2 + \frac{\alpha_4}{3} \right) d_1^2 \right\} \quad (23).$$

Where d = distance of centre of top flange above the neutral axis,

d_1 = distance of centre of bottom flange below the neutral axis,

α_1 = area of top flange,

α_2 = area of bottom flange,

α_3 = area of web above the neutral axis,

α_4 = area of web below the neutral axis,

f = stress on the extreme fibres at the top of the beam,

f_1 = stress on the extreme fibres at the bottom of the beam.

If $\frac{f_1}{d_1} < \frac{f}{d}$, $\frac{f_1}{d_1}$ must be taken as the multiple instead of $\frac{f}{d}$

When the flanges of the beam are equal to each other, the neutral axis passes through the centre of the web.

If d_0 = depth between the centres of the flanges,

a_1 = area of each flange,

a_2 = area of the web,

equation (23) may be written—

$$\mu = f d_0 \left(a_1 + \frac{a_2}{6} \right),$$

which agrees with equation (14), as already determined.

142. Beams of T-Section.

Let b_1 = width of flange,

b = thickness of web,

d = distance of centre of gravity from edge of web,

d_1 = " " " outside edge of flange,

d_2 = " " " inside " "

Then since from equation (e), p. 149,

$$I = \frac{1}{3} \{ b d^3 + b_1 d_1^3 - (b_1 - b) d_2^3 \}$$

we have
$$u = \frac{f}{3d} \{ b d^3 + b_1 d_1^3 - (b_1 - b) d_2^3 \},$$

or,
$$\mu = \frac{f_1}{3d_1} \{ b d^3 + b_1 d_1^3 - (b_1 - b) d_2^3 \} \quad (24).$$

Where f = unit-stress on fibres at a distance d from the neutral axis,

f_1 = unit-stress on fibres at a distance d_1 from the neutral axis.

The multiple $\frac{f}{3d}$ or $\frac{f_1}{3d_1}$ is to be taken, whichever is least.

143. Discrepancies between Theory and Practice in Determining the Strength of Solid Beams.—The theory which has been given for determining the strengths of beams cannot be rigidly applied. Certain modifications have to be made to suit beams of different sections.

For a beam of rectangular section—

$$\mu = f \frac{b d^2}{6}.$$

If a weight, W , rests on the centre of such a beam whose span is l , we get—

$$M = \frac{Wl}{4}.$$

Substituting this value of M in the previous equation, we get (since $\mu = M$)—

$$\frac{Wl}{4} = f \frac{bd^2}{6}, \text{ or } W = \frac{2}{3}f \cdot \frac{bd^2}{l} \quad (25).$$

If W be the breaking weight of the beam, f ought to represent the ultimate compressive or tensile strength per unit of area of the extreme fibres; the strength of the beam, however, as determined from experiment, does not confirm this view.

We will explain this by means of an example.

Example 2.—What weight applied at the centre of a cast-iron bar 1" square, placed on two supports 60" apart, will break it, the tensile strength of the iron being 9 tons per square inch, and its direct crushing strength 50 tons per square inch?

This bar will fail by the fibres at the bottom tearing apart, and, according to the theory propounded, this will take place when the stress on them = 9 tons per square inch. Consequently we must put $f = 9$ tons, $b = d = 1$, $l = 60$, in equation (27) when we get—

$$W = \frac{2}{3} \times \frac{9 \times 1}{60} \text{ tons} = 2 \text{ cwts.}$$

Now, if this bar be tested experimentally by applying gradually increasing weights at its centre, it will (if sound) probably support 500 lbs. before failure takes place. In other words, its actual strength is between 2 and 3 times that found according to the foregoing calculation.

In the case of round bars, or square bars with one diagonal vertical, the discrepancy between the theoretical and actual results is still greater.

Various explanations have been given to account for these discrepancies in the strengths of solid beams, but none of them appear to be quite satisfactory. One explanation is that when a beam is loaded transversely, the position of the neutral axis which at first passed through the centre of gravity of the section gradually shifted its position as the load was increased. This assumption does not seem improbable in the case of a material like cast iron, in which the ultimate tensile and compressive strengths differ materially from each other.

It is also probable that the lateral action between the different fibres of solid beams, which are exposed to different stresses, tends to equalise the stresses, and thereby accounts for the discrepancy.

To illustrate the effect of this lateral action, let a, b, c, d (fig. 82) represent, say, a plate of iron, and suppose it be exposed to a tensile stress close to the edge $a b$. If the plate be a short one the fibres which are exposed to the greatest stress will be those close to the edge $a b$; but these are not the only fibres strained, for owing to the lateral adhesion between them, a portion of the

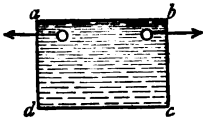

Fig. 82.

the stress on those at $a b$ will be communicated to those next to them, and these in their turn will communicate a portion of their stress to their neighbours, and so on, until the opposite edge $d c$ is reached, so that the maximum stress will occur on the fibres at $a b$ and the minimum stress on those at $d c$.

In the case of flanged girders with thin webs, the value of f , as found by experiment, agrees very nearly with the ultimate tensile or compressive strength of the material, whichever is least; but in beams of solid section it varies according to the section.

Professor Rankine, instead of calling f the ultimate strength of the fibres, calls it the *modulus of rupture*, and assigns to it different values, according to the material and also to the section of the beam. These values are given in Table XVIII., and by using the proper value of f the various formulæ given may be applied with confidence in determining the strengths of beams.

TABLE XVIII.—MODULI OF RUPTURE (f) OF BEAMS OF DIFFERENT SECTIONS AND DIFFERENT MATERIALS.

MATERIALS.	Modulus of Rupture (f) in Tons.
<i>Cast Iron.</i>	
Small rectangular bars (not exceeding 1 inch in width),	20·4
Large rectangular bars (3 inches wide),	13·5
Rectangular bars of Salisbury iron, U.S.A. (not exceeding 1 inch in width),	24·0
Small round bars 1 inch diameter,	23·0
„ „ 2 inches „	20·0
Beams of I-section, from,	7·5
„ to	15·0

TABLE XIX.—SQUARE BARS OF CAST IRON BROKEN ON THEIR SIDES,
SPAN 60 INCHES.

Depth.	Breadth.	Sectional Area.	Breaking Weight.	Value of f .
Inches.	Inches.	Sq. Inches.	Lbs.	Lbs.
1·01	1·02	1·030	505	43,689
1·01	1·025	1·035	505	43,492
1·01	1·02	1·030	561	48,534
1·02	1·025	1·045	533	45,004
1·00	1·02	1·020	533	47,030
Mean.	1·010	1·020	527	45,550

TABLE XX.—SQUARE BARS OF CAST IRON BROKEN ON THEIR SIDES,
SPAN 60 INCHES.

Depth.	Breadth.	Sectional Area.	Breaking Weight.	Value of f .	
Inches.	Inches.	Sq. Inches.	Lbs.	Lbs.	
1·985	2·020	4·010	3,303	36,700	
1·990	2·015	4·010	3,303	36,790	
2·010	2·010	4·040	3,443	38,160	
2·000	1·990	3·980	3,863	43,896	
Mean.	1·996	2·009	4·010	3,478	38,866

The values of f in Tables XIX. and XX. are calculated from the equation—

$$f = \frac{3}{2} \cdot \frac{W l}{b d^2}.$$

TABLE XXI.—SQUARE BARS OF CAST IRON BROKEN ON THEIR ANGLE,
SPAN 60 INCHES.

Depth.	Side of Square.	Sectional Area.	Breaking Weight.	Value of f .	
Inches.	Inches.	Sq. Inches.	Lbs.	Lbs.	
1.442	1.020	1.040	449	53,945	
1.467	1.037	1.076	421	48,134	
1.450	1.025	1.050	449	53,160	
1.428	1.010	1.020	449	55,564	
1.428	1.010	1.020	477	59,031	
Mean	1.443	1.020	1.041	449	53,973

The values of f in Table XXI. are calculated from the equation—

$$f = \frac{8.5 W l}{4 b^3}.$$

TABLE XXII.—SOLID CYLINDRICAL BARS OF CAST IRON
SPAN 60 INCHES.

Mean Diameter.	Sectional Area.	Breaking Weight.	Value of f .
Inches.	Sq. Inches.	Lbs.	Lbs.
1.145	1.030	519	52,860
1.113	0.972	505	56,017
1.115	0.976	449	49,511
1.118	0.981	449	49,127
1.120	0.985	449	48,840
Mean, 1.122	0.989	474	51,271

The values of f in Tables XXII. and XXIII. are calculated from the equation—

$$f = \frac{W l}{\pi r^3}$$

TABLE XXIII.—SOLID CYLINDRICAL BARS OF CAST IRON,
SPAN 60 INCHES.

Mean Diameter.	Sectional Area.	Breaking Weight.	Value of f .
Inches.	Sq. Inches.	Lbs.	Lbs.
2.52	4.987	4,283	40,897
2.52	4.987	4,283	40,897
2.52	4.987	4,003	38,223
2.51	4.948	4,003	38,524
Mean, 2.52	4.977	4,143	39,635

TABLE XXIV.—CAST-IRON BEAM OF H-SECTION, WITH EQUAL FLANGES,
WEB VERTICAL, SPAN 48 INCHES.

Total Depth.	Thickness of each Flange.	Depth of Web.	Width of each Flange.	Thickness of Web.	Sectional Area.	Breaking Weight.	Value of f .
Inches.	Inch.	Inches.	Inches.	Inch.	Sq. In.	Lbs.	Lbs.
1.97	.495	.98	1.99	.55	2.51	3,310	33,878
2.00	.500	1.00	1.97	.47	2.47	3,560	35,950
2.01	.505	1.00	2.02	.48	2.52	3,735	36,366
2.08	.555	.97	2.07	.53	2.81	3,910	34,005
2.07	.53	1.01	2.02	.52	2.67	4,528	40,784
2.07	.51	1.05	2.04	.47	2.57	4,563	41,582
2.06	.52	1.02	2.09	.53	2.71	4,423	40,060
Mean 2.04	.51	1.00	2.03	.50	2.60	4,004	37,512

The value of f in Table XXIV. is calculated from the equation—

$$f = \frac{3}{2} \times \frac{W d l}{b d^3 - (b - b_1) d_1^3}$$

These experiments are instructive in showing how, in bars of the same material, the modulus of rupture varies according to the section. It will be noticed that the smaller the section the greater is the modulus. Roughly speaking, with bars 1 inch square broken on their sides the modulus is 20 tons, while with those 2 inches square the modulus is only 17 tons. Again, with 1 inch square bars placed with a diagonal vertical, the modulus is as high as 24 tons, and with circular bars 1 inch diameter it is 23 tons. When the diameter of the circular bars is increased to $2\frac{1}{4}$ inches, the modulus is found to be reduced to 18 tons. As is to be expected in those bars which have most material in the neighbourhood of the neutral axis, the modulus is highest. For example, comparing a circular bar, 1 inch diameter, and a beam of H-section, 1 inch deep, the respective moduli are 23 and 16.75 tons.

144. Solid Rectangular Cantilevers Loaded Uniformly.—

Let W = load uniformly distributed,
 l = length of semi-girder,
 b = breadth of beam,
 d = depth of beam.

$$\text{Moment of resistance } \mu = f \cdot \frac{b d^2}{6}.$$

$$\text{Maximum bending moment } M = \frac{W l}{2}.$$

$$\text{We, therefore, have } \frac{W l}{2} = f \cdot \frac{b d^2}{6};$$

$$\text{or } W = f \cdot \frac{b d^2}{3 l} \quad . \quad . \quad (26).$$

Example 3.—One end of a rectangular beam of oak, 10 feet long, 4 inches wide, and 6 inches deep, is fixed in a wall; what load distributed over its length will break it, the coefficient of rupture of oak being five tons?

Here we have $f = 5$ tons, $b = 4$ inches, $d = 6$ inches, $l = 120$ inches.

Substituting these values in equation (26), we get—

$$W = \frac{5 \times 4 \times (6)^2}{3 \times 120} = 2 \text{ tons.}$$

Example 4.—One end of a bar of cast iron, 4 inches square, was firmly fixed, the projecting portion being 6 feet. Weights

equally distributed were gradually applied until the bar broke. Determine the moment of rupture of the bar, the breaking weight being 4 tons.

From equation (26) we get by transposing—

$$f = \frac{3 W l}{b d^2}.$$

Substituting the values given above in this equation, we find—

$$f = \frac{3 \times 4 \times 72}{(4)^2} = 13.5 \text{ tons.}$$

145. Solid Rectangular Cantilever loaded at the Free End.—Adopting the usual notation we get—

$$\mu = \frac{f b d^2}{6}, \quad M = W l.$$

Equating these, we get—

$$W l = \frac{f b d^2}{6},$$

$$\text{or, } W = \frac{f b d^2}{6 l} \quad . \quad . \quad . \quad (27).$$

Example 5.—What weight suspended from the end of a rectangular cantilever of wrought iron, 2 inches wide and 3 inches deep, will break it, the length of the cantilever being 5 feet, and the modulus of rupture of the bar being 24 tons?

From equation (27) we have—

$$W = \frac{24 \times 2 \times (3)^2}{6 \times 60} = 1.2 \text{ tons.}$$

Bars of wrought iron of this section rarely actually break, but they become so bent that their utility is destroyed, and for all practical purposes they may be considered to be fractured.

Example 6.—A square bar of soft steel, 3 feet long, is fixed in a cantilever form. What must be the section of the bar, so that a weight of 2 tons hung from its end will just produce fracture, the modulus of rupture being 36 tons?

Let d = side of the bar in inches.

From equation (27) we get—

$$d^2 = \frac{6 W l}{f}, \quad \text{or } d = \left(\frac{6 W l}{f} \right)^{\frac{1}{2}}.$$

Substituting the values given in the example, we get—

$$d = \left(\frac{6 \times 2 \times 36}{36} \right)^{\frac{1}{2}} = (12)^{\frac{1}{2}} = 2.3 \text{ inches nearly.}$$

Example 7.—In the last example, if the depth of the bar be 2 inches, what must be its width in order to support the weight? From equation (27)—

$$b = \frac{6 W l}{f d^2} = \frac{6 \times 2 \times 36}{36 \times (2)^2} = 3 \text{ inches.}$$

Example 8.—If the bar in example (6) be 3 inches wide and 4 inches deep, what weight suspended at the centre of the cantilever, in addition to the 2 tons at the extremity, will cause failure? Let W = required weight.

The maximum bending moment is

$$M = 2 \times 36 + 18 \times W.$$

Equating this to the moment of resistance of the section, we obtain—

$$18 W + 72 = \frac{f b d^2}{6} = \frac{36 \times 3 \times (4)^2}{6} = 288.$$

$$\therefore W = 12 \text{ tons.}$$

146. Solid Rectangular Beams supported at both Ends and Loaded at the Centre.—

$$\mu = \frac{f b d^2}{6}. \quad M = \frac{W l}{4},$$

$$\therefore W = \frac{2}{3} \cdot \frac{f b d^2}{l} \quad \dots \quad (28).$$

147. Solid Rectangular Beams supported at both Ends and Loaded Uniformly.—

$$\mu = \frac{f b d^2}{6}. \quad M = \frac{W l}{8}.$$

$$W = \frac{4}{3} \cdot \frac{f b d^2}{l} \quad \dots \quad (29).$$

Example 9.—A beam of cast iron, whose section is 5 inches square, is placed upon two props 10 feet apart. What weight, placed at its centre, will cause fracture, the modulus of rupture being 14 tons?

From equation (28)—

$$W = \frac{2}{3} \times \frac{14 \times 5 \times (5)^2}{120} = 9.7 \text{ tons.}$$

Example 10.—In the last example, if the beam be placed so that a diagonal of the cross-section is vertical, what is the breaking weight at the centre, the modulus of rupture being 16 tons?

In this case, since from equation (7),

$$\mu = \frac{f b^3}{8.5},$$

$$\therefore W = \frac{4}{8.5} \cdot \frac{f b^3}{l} = \frac{4}{8.5} \times \frac{16 \times (5)^3}{120} = 7.84 \text{ tons.}$$

From equations (6) and (7) it is seen that the strength of a beam of square section with a side vertical is to that of the same beam with a diagonal vertical, as 8.5 : 6, on the understanding that the moment of rupture (f) in both cases is the same. With some materials, however, notably cast iron, the moment of rupture in the latter case is somewhat greater than in the former, on account of there being more material in the neighbourhood of the neutral axis of the section, the proportion of the moments of rupture in the two cases for small sections being something like 10 to 9. This has the effect of reducing the relative strength of cast-iron bars with a side vertical to a diagonal vertical from $\frac{8.5}{6}$ to $\frac{8.5}{6} \times \frac{9}{10}$ or about $\frac{6.4}{5}$. In the example just considered, this proportion is as 9.7 to 7.84.

Example 11.—A beam of spruce, 6 inches wide by 9 inches deep, rests on two supports 15 feet apart; what weight per lineal foot distributed over the beam will cause it to break, the moment of rupture of spruce being 5 tons?

Let W = required weight per foot in tons.

From equation (29), we have—

$$W \times 15 = \frac{4}{3} \cdot \frac{5 \times 6 \times (9)^2}{180} = 18 \text{ tons,}$$

$$\text{or } W = 1.2 \text{ tons.}$$

Example 12.—In the last example, what distance apart must the supports be so that the beam may break by its own weight, the weight of a cubic inch of spruce being .0185 lbs.?

Let l = required span in inches,
 W = weight of the beam in pounds,
 f = moment of rupture in pounds.

From equation (29), we get—

$$W = \frac{4}{3} \times \frac{11200 \times 6 \times (9)^2}{l} = \frac{7257600}{l}.$$

Also $W = 6 \times 9 \times l \times 0.165 = l.$

Equating these two values of W , we get—

$$l = \frac{7257600}{l}, \text{ or } l = 2,694 \text{ inches.}$$

When the length of the beam, therefore, is 224.5 feet it will break by its own weight.

Example 13.—A square bar of cast iron, 3 inches by 3 inches, rests on two supports 60 inches apart. A weight of 3 tons is suspended from the centre of the bar. What additional weight suspended at one foot from the centre will break it?

Let W = required weight in tons.

The maximum bending moment takes place at the centre of ^{providing} the beam, and equals (45 + 9 W) inch-tons. W < 5 Tons

The moment of resistance of the section of the bar is $\mu = \frac{15 \times 27}{6} = 67.5$ inch-tons, the modulus of rupture being taken at 15 tons per inch.

Equating these two expressions, we have—

$$9W + 45 = 67.5,$$

$$\text{or } W = 2.5 \text{ tons.}$$

A weight of 2.5 tons, therefore (in addition to the central load of 3 tons), placed at 1 foot from the centre of the bar, will cause it to break at the centre.

Example 14.—A round bar of cast iron is placed upon two supports 6 feet apart. A weight of 2 tons hung from a point 2 feet 6 inches from one of the bearings is just sufficient to fracture it. What must be the diameter of the bar if the modulus of rupture = 20 tons per square inch?

Let r = radius of the section of bar.

From equation (8),

$$M = .7854 f r^3.$$

The weakest part of the bar, or the point where the maximum bending moment occurs, is at the point of application of the weight. At this point

$$M = 35 \text{ inch-tons,}$$

consequently

$$.7854 f r^3 = 35,$$

$$.7854 \times 20 \times r^3 = 35, \text{ or } r = 1.3 \text{ inches,}$$

which gives the diameter of the bar = 2.6 inches.

Example 15.—A timber bridge crossing a rivulet 20 feet wide is supported by two main beams of ash 14 inches square. The dead weight of the bridge is 4 tons. What is the maximum safe concentrated load it would be advisable to roll across the centre of the bridge?

The moment of rupture for ash is about 6 tons. One-sixth of this, or 1 ton, may be taken as a safe working load, so that if—

$$W = \text{breaking weight, then } \frac{W}{6} = \text{required load.}$$

Dead load (distributed) on one beam = 2 tons.

$$\left. \begin{array}{l} \text{The breaking live load (concentrated)} \\ \text{on one beam} \end{array} \right\} = \frac{W}{2}.$$

The maximum bending moment on the beam occurs at its centre when W rests on the centre of the bridge, in which case

$$M = 60 + 30 W,$$

M being expressed in inch-tons. Moment of resistance of the beam

$$= \frac{f d^3}{6} = \frac{6 \times (14)^3}{6} = 2,744 \text{ inch-tons,}$$

we get, therefore,

$$60 + 30 W = 2,744, \text{ or } W = 89.4 \text{ tons;}$$

and required safe load

$$= \frac{89.4}{6} = 14.9 \text{ tons.}$$

SOLID RECTANGULAR BEAMS SUPPORTED AT BOTH ENDS. 175

Example 16.—A hollow tube of mild steel, 12 inches external, and 11 inches internal diameter, is placed upon two supports 15 feet apart. What weight placed at its centre will cause it to collapse, the tube being properly stiffened?

The ultimate strength of mild steel is about 30 tons per square inch.

$$f=30, \quad r=6, \quad r_1=5.5, \quad l=180 \text{ inches.}$$

W = required breaking weight.

The maximum bending moment is $M=45 W$ inch-tons.

Substituting this in equation (9) we have—

$$45 W = \frac{.7854 \times 30}{6} \{(6)^4 - (5.5)^4\} = 1,496,$$

$$\text{or, } W = 33.24 \text{ tons.}$$

The breaking weight may be found approximately from equation (10), by putting $t = .5$ inch, thus—

$$45 W = 3.1416 \times 30 \times (6)^2 \times .5 = 1,696,$$

$$\text{or, } W = 37.7 \text{ tons.}$$

A result which is somewhat greater than that previously found.

Example 17.—What must be the thickness of a wrought-iron tube, 12 inches external diameter, and properly stiffened, in order to carry with safety a load of 5 tons placed centrally between two supports 8 feet apart, the safe working load of the iron being taken at 4 tons per square inch?

Maximum bending moment, $M = 120$ inch-tons.

From equation (10) we get—

$$t = \frac{M}{\pi f r^2} = \frac{120}{3.1416 \times 4 \times (6)^2} = 0.27 \text{ inch.}$$

Example 18.—A tube of cast iron, 9 inches square, outside measurement, and $\frac{1}{2}$ inch thick, rests on two props 12 feet apart. What is the greatest distributed load it will carry, so that the maximum stress on the fibres may not exceed 2 tons per square inch?

$$d=9, \quad d_1=8, \quad f=2, \quad l=144.$$

Let W = required distributed load in tons.

$$\text{Maximum bending moment, } M = \frac{W l}{8} = 18 W.$$

Substituting this in equation (12), we obtain—

$$18 W = \frac{f}{6d} (d^4 - d_1^4) = \frac{2}{6 \times 9} \{(9)^4 - (8)^4\},$$

or, $W = 5.07$ tons.

The result, as found by the approximate formula (12a), is—

$$18 W = \frac{4}{3} \times 2 \times (9)^2 \times \frac{1}{2},$$

or, $W = 6$ tons.

Example 19.—In the last example, if the tube be of wrought iron, what must be its thickness in order to support weights of 4 tons and 6 tons placed at distances of 6 and 8 feet respectively from the left support, without producing a greater stress than 5 tons to the square inch on the extreme fibres of the tube?

$$f = 5, \quad d = 9, \quad t = \text{required thickness in inches.}$$

The maximum bending moment occurs at all sections between the points of application of the weights, and its value is $M = 288$ inch-tons.

From equation (12a)—

$$t = \frac{3}{4} \cdot \frac{M}{f d^2}.$$

Substituting the above values, we get—

$$t = \frac{3}{4} \frac{288}{5 \times (9)^2} = 0.53 \text{ inch.}$$

Example 20.—A wrought-iron rivetted girder of H-section rests on two abutments placed 60 feet apart, and is uniformly loaded with 1 ton per lineal foot, including the weight of the girder; the sectional area of the top flange = 11 inches, and that of the bottom 9 inches net. What is the stress per square inch on the flanges, if the depth of the girder = 10 feet?

$$\frac{1}{2} W = 60 \text{ tons,} \quad l = 60 \text{ feet,} \quad d = 10 \text{ feet.}$$

If S = total stress on either flange, from equation (19), we find—

$$S = \frac{60 \times 60}{8 \times 10} = 45 \text{ tons.}$$

$$\text{Stress per square inch on top flange} = \frac{45}{11} = 4.1 \text{ tons.}$$

$$\text{Stress per square inch on bottom flange} = \frac{45}{9} = 5 \text{ tons.}$$

Example 21.—A steel solid-web girder, 50 feet span and 5 feet deep, supports a distributed load of $\frac{3}{4}$ ton per foot and two concentrated loads of 5 tons each, placed at a distance of 5 feet at each side of the centre. Determine the maximum stress on the flanges, and state convenient sections for the top and bottom flanges, if they are exposed to stresses of 6 tons and 7 tons respectively.

The maximum bending moment occurs at the centre of the girder.

$$\begin{aligned}
 &\left. \begin{array}{l} \text{Bending moment at the centre for} \\ \text{the distributed load} \end{array} \right\} = 234.375 \text{ foot-tons,} \\
 &\left. \begin{array}{l} \text{Bending moment at the centre for} \\ \text{the concentrated loads} \end{array} \right\} = 100.0 \quad \text{"} \\
 &\text{Total bending moment at the centre} = 334.375 \quad \text{"} \\
 &\text{Flange stress at the centre of girder} = \frac{334.375}{5} = 66.87 \text{ tons,} \\
 &\left. \begin{array}{l} \text{Gross section of top flange at centre} \\ \text{of girder} \end{array} \right\} = \frac{66.87}{6} = 11.14 \text{ sq. ins.,} \\
 &\left. \begin{array}{l} \text{Net section of bottom flange at} \\ \text{centre of girder} \end{array} \right\} = \frac{66.87}{7} = 9.55 \text{ sq. ins.}
 \end{aligned}$$

The following sections may be used—

$$\begin{array}{l}
 \text{Top flange, . . .} \\
 \text{Bottom flange, .}
 \end{array}
 \left\{
 \begin{array}{l}
 \begin{array}{l}
 1 \text{ plate, . . . } 12 \times \frac{1}{4} = 6 \text{ sq. ins.} \\
 2 \text{ angles, . . . } 3 \times 3 \times \frac{1}{4} = 5.5 \quad \text{"} \\
 \hline
 \text{Total area of flange, . } 11.5 \quad \text{"}
 \end{array} \\
 \begin{array}{l}
 1 \text{ plate, . . . } 12 \times \frac{9}{8} = 6.75 \quad \text{"} \\
 2 \text{ angles, . . . } 3 \times 3 \times \frac{1}{4} = 5.5 \quad \text{"} \\
 \hline
 12.25 \quad \text{"} \\
 \text{Allowance for rivet-holes, } 2.625 \quad \text{"} \\
 \hline
 9.625 \quad \text{"}
 \end{array}
 \end{array}
 \right.$$

These sections of flanges should occur for at least 15 feet at the centre of the girder. If great economy be desired, the flange plates for the remainder of the girder may be made $\frac{5}{8}$ " or $\frac{3}{4}$ " in thickness. Practically, however, there is not much gained by this, and in girders of this section it will generally be found

advisable to continue the thicker section of plate to the ends of the girder. Theoretically the flanges for a considerable distance towards the ends would be strong enough with the angles alone without any plate, but a girder of this kind looks unfinished, and is deficient in lateral stiffness, and for other reasons it is not advisable to dispense with the plate.

The maximum shearing stress on the web occurs at the edge of each abutment, and = 23.75 tons.

If the maximum shearing stress per square inch of gross sectional area be taken at 3 tons, the section of the web at the abutments theoretically should be $\frac{23.75}{3} = 8$ square inches, and as the depth of the web = 60 inches, its thickness would be $\frac{8}{60} = .133$ inch. In solid plate web girders the thickness of the web, however, is seldom taken less than $\frac{5}{16}$ inch. If less than this, it would have comparatively little stiffness, and would be liable to bulge with compressive stresses. Even at this and greater thickness, it will be found necessary to introduce vertical stiffeners to keep the web straight and to give lateral rigidity to the girder. Another objection to using thin webs is that in the course of time their strength is materially affected by corrosion.

Example 22.—In the last example, with the sections of flanges given, what extra weight placed at the centre of the girder will break it, the ultimate tensile strength of the steel being 32 tons, and its ultimate compressive strength being 28 tons per square inch?

The top flange will be crushed with a total stress of $11.5 \times 28 = 322$ tons.

The bottom flange will be torn with a total stress of $9.625 \times 32 = 308$ tons.

The bottom flange theoretically will, therefore, fail before the top one and when the stress at the centre = 308 tons.

We have seen in the last example that the distributed load and two concentrated loads produce a stress of 66.87 tons at the centre of each flange. The question, therefore, resolves itself into this—What weight placed on the centre of the girder will produce a flange stress at the centre equal to $308 - 66.8 = 241.2$ tons?

Let W = required weight in tons.

From the well-known equation (18), we get—

$$W = \frac{4 d S}{l}; \text{ or } W = \frac{4 \times 5 \times 241.2}{50} = 96.5 \text{ tons.}$$

Example 23.—A railway bridge, 150 feet span, carrying a double line of rails, is supported by two main wrought-iron lattice girders 15 feet deep. If the dead weight of the structure between the abutments = 400 tons and the weight of each train of carriages = $1\frac{1}{2}$ tons per foot, what must be the sections of the booms of the girders at their centres, allowing a factor of safety of 4 for the dead load and 5 for the live load, the ultimate strength of the iron being 20 tons per square inch?

Total dead load on one girder = 200 tons distributed,

Total live load on one girder = 225 tons distributed.

Let S and S_1 represent the flange stresses produced by these loads respectively at the centre of the girder.

$$S = \frac{200 \times 150}{8 \times 15} = 250 \text{ tons,}$$

$$S_1 = \frac{225 \times 150}{8 \times 15} = 281 \text{ tons.}$$

The dead load requires $\frac{250}{5} = 50$ square inches of sectional area at the centre of the flange.

The live load requires $\frac{281}{4} = 70.25$ square inches.

The total sectional area of each flange, therefore, at the centre of the girder must be 120.25 square inches.

If the stress be computed on the net sectional area of the flange, the section of boom given in fig. 83 would be a suitable one for this girder. It will be noticed that it is arranged for a box girder, the vertical plates being for the purpose of connecting the lattice bars to the booms. It must be understood that the 15 feet given as the depth of the girder means the distance between the centres of gravity of the sections of the booms, the actual depth of the girder being somewhat more than this.

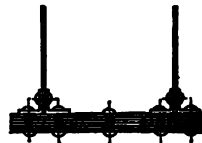

Fig. 83.

The net section of the boom may be computed as follows:—

6 horizontal plates $32'' \times \frac{1}{2}'' = 96$ sq. ins.	
2 vertical plates $18'' \times \frac{3}{4}'' = 27$ „	
4 angles $\frac{4}{4}'' \times \frac{4}{4}'' \times \frac{5}{8}'' = 18.4$ „	
	141.4 total gross area.
Allow for 1'' rivet-holes, 18.0	
	123.4 total net area.

This allows a slight margin in excess of the area required.

ROLLED GIRDERS.

Rolled girders are made of wrought iron and also of mild steel; those made of the latter material being much stronger and not much more costly, are coming very much into favour.

In the Table (XXV., p. 186) the ultimate tensile strength of the wrought iron is assumed to be 20 tons per square inch, and that of the steel 30 tons. The moment of inertia given is that taken with respect to a horizontal axis passing through the centre of gravity of the section, and as the top and bottom flanges are equal, this point will be in the centre of the web.

In order to explain the Table, we will go through the process of calculating the moments of inertia and resistance, and the breaking weight for No. 1 section.

The formula for the moment of inertia of a H-section with equal flanges with respect to an axis passing through its centre of gravity and parallel to the flanges is (see Chap. IX.)—

$$I = \frac{1}{12} \{b d^3 - (b - b_1) d_1^3\}.$$

Applying this to the girder under consideration we have

$$\begin{aligned} d &= 20, & d_1 &= 18.06, \\ b &= 8.26, & b_1 &= .76, \end{aligned}$$

so that

$$I = \frac{1}{12} \{8.26 (20)^3 - 7.5 (18.06)^3\} = 1825.1 \text{ inch-units.}$$

Next, to find the moment of resistance of the section (μ). This is found from the general equation $\mu = \frac{f}{h} \times I$; and as $h = 10$, $I = 1,825$, $f = 20$ and 30 tons for wrought iron and steel respectively, by substituting these values, we get—

$$\mu \text{ (for wrought iron)} = \frac{20}{10} \times 1,825 = 3,650 \text{ inch-tons,}$$

$$\mu \text{ (for steel)} = \frac{30}{10} \times 1,825 = 5,475 \text{ inch-tons.}$$

Lastly, to find the breaking load on a girder of 1 foot span. If W = required breaking load in tons distributed, the maximum bending moment of the girder is—

$$M = \frac{W \times 12}{8} = \frac{3}{2} W \text{ inch-tons,}$$

and as $M = \mu$, we obtain—

$$\frac{3}{2} W = 3,650, \text{ or } W = 2,433 \text{ tons for iron,}$$

$$\frac{3}{2} W = 5,475, \text{ or } W = 3,650 \text{ tons for steel.}$$

Knowing the breaking load for a span of one foot, the breaking load for any other span may be found by dividing the former load by the number in feet.

For example, the breaking load of the girder under consideration for a span of 20 feet is—

$$\text{Breaking load in tons} = \frac{2433}{20} = 121.6 \text{ tons for iron girder.}$$

$$\text{'' ''} = \frac{3650}{20} = 182.5 \text{ tons for steel girder.}$$

If the ends of the girders be fixed by being built into a wall or otherwise, their strengths will be greater than those given by the table. The amount of extra strength imparted to them by thus fixing their ends altogether depends on the efficacy with which it is done. If the ends be *firmly* fixed, their strengths will be theoretically doubled, as shown in the chapter on bending moments. Practically, however, this is rarely the case; the ratio, as found by experiment, between beams with fixed and unfixed ends, is not often more than 3 to 2, and this is only when the fixing is properly done. With independent girders (as used in warehouses for supporting walls and floors), it is always best to ignore this addition of strength, and to consider them as if their ends were entirely free.

The allowance usually made for the load on floors is—

Dwelling-houses, . . .	$1\frac{1}{2}$ cwts. per square foot.
Public buildings, . . .	$1\frac{1}{2}$ " "
Warehouses, . . .	$2\frac{1}{2}$ to 3 " "

Example 24.—It is required to construct a floor to a warehouse to be carried by steel-rolled girders. The span between the side walls is 20 feet; the main girders are to rest on these walls and to be placed 10 feet apart. On these girders are to rest smaller girders running transversely with them and placed 3 feet apart; on these latter a 4" timber floor is laid. The greatest live load estimated to come on the floor is 3 cwts. per square foot distributed over its surface. Determine suitable sections for the girders.

LOAD ON ONE MAIN GIRDER.

4" timber planking, . . .	$\frac{20 \times 10 \times 4}{12} \times 40 \text{ lbs.} = 1.2 \text{ tons.}$
Estimated weight of steel in girders . . .	$= 1.4 \text{ ,,}$
Live load,	$20 \times 10 \times 3 \text{ cwt.} = 30.0 \text{ ,,}$
Total load,	32.6 —say 33 tons.

The working load on each main girder is, therefore, 33 tons.
 The breaking load = $4 \times 33 = 132$ tons.
 The breaking load for a span of 1 foot = $132 \times 20 = 2,640$ tons.
 Referring to the Table we find the nearest section which corresponds with this is No. 2, or a steel joist 18" \times 7".
 Next consider the cross-beams :—

LOAD ON ONE CROSS-BEAM.

4" timber planking, . . .	$\frac{10 \times 3 \times 4}{12} \times 40 \text{ lbs.} = 0.18 \text{ tons.}$
Estimated weight of beam,	$= 0.1 \text{ ,,}$
Live load,	$10 \times 3 \times 3 \text{ cwts.} = 4.5 \text{ ,,}$
Total load,	4.78 —say 5 tons.

The breaking load on cross-girder = $5 \times 4 = 20$ tons.
 The breaking load for a span of 1 foot = $20 \times 10 = 200$ tons.
 By referring to the Table we find a suitable girder is No. 11, which weighs 16 lbs. per foot.

If the cross-girders be continuous over two or more spans their strength is increased in the proportion explained in the chapter on *Bending moments* (see Arts. 96 to 98).

Example 25.—A rolled iron girder of No. 3 section rests on two abutments 15 feet apart. Determine (1) what weight placed at the centre will break it; (2) what weight placed 5 feet from one abutment will break it.

(1) From the Table it is seen that the distributed breaking weight in tons = $\frac{1218}{15} = 81.2$ tons.

The central weight, therefore, = $\frac{81.2}{2} = 40.6$ tons.

(2) In the second case, the maximum bending moment occurs at the point of application of the weight.

If W = required weight, the bending moment = $\frac{10}{3} W$ foot-tons, or = $40 W$ inch-tons. This must be equal to the moment of resistance of the section, or

$$40 W = 1,827. \quad W = 45.675 \text{ tons.}$$

Example 26.—In the last example, if two weights of 10 and 15 tons be placed on the girder at two points 18 inches at each side of the centre, what is the maximum tensile or compressive stress per square inch on the fibres?

The maximum bending moment occurs at the point of application of the 15 tons, and is equal to 78 foot-tons, or 936 inch-tons.

If f = stress in tons per square inch on the flanges,
 h = half the depth of girder = 8 inches,
 I = moment of inertia of section = 731.

Then from equation $\mu = \frac{f}{h} \times I$ we get, by putting $\mu = 936$,

$$f = \frac{936 \times 8}{731} = 10.24 \text{ tons.}$$

Example 27.—Two rolled-steel girders placed side by side, span an opening of 16 feet. They are required to support a brick wall 20 feet high and $17\frac{1}{2}$ inches in thickness. A cross-beam is also suspended from their centres, which imposes on them an extra weight of 10 tons. Determine a suitable section for the girders.

The weight of a cubic foot of brickwork is about 100 lbs.

Total weight of brickwork = $20 \times 16 \times 1.45 \times 100$ lbs. = 20.7 tons,
 Estimated weight of girders between abutments = 1.3 ,,

Total distributed load on two girders . . . = 22.0 ,,

Each girder, therefore, is loaded with a distributed weight of 11 tons, and a concentrated central weight of 5 tons. The maximum bending moment occurs at the centre of the girder, and is equal to 42 foot-tons, or 504 inch-tons.

If the steel be strained to one-fourth of its breaking weight, the moment of resistance of the section must be equal to four times the maximum bending moment, or = $504 \times 4 = 2,016$.

In looking down the column of the moments of resistance in the Table, we find that girders 4, 5, and 6 give results nearest to what is required, and as No. 4 or a $15'' \times 5''$ girder is the lightest, it is the most economical to use. This girder will give a margin of strength, as the estimated weight of the two girders, or 1.3 tons, is considerably in excess of their actual weight.

If iron girders be used instead of steel, it will be necessary to use No. 2 section, which weighs 81.6 lbs. per foot.

If the girders have a bearing on each abutment of 15 inches, we have—

Weight of steel girders = $37 \times 50 = 1,850$ lbs.,

Weight of iron girders = $37 \times 81.6 = 3,019$ lbs.

148. Approximate Method of Calculating the Strength of Rolled Girders.—The method of determining the strengths of rolled girders, which we have been considering, involves the determination of their moments of inertia and resistance; the calculation of these quantities is somewhat tedious, and where very great accuracy is not necessary, a shorter and much simpler rule may be adopted, which we will now proceed to explain. By this latter method the aid which the web supplies in resisting the horizontal stresses is left out of consideration, so that the strength of the girder as thus found is somewhat less than its real strength. This discrepancy is somewhat modified by taking as the effective depth of the girder its *extreme depth* over all, instead of the depth between the centres of gravity of the flanges.

Let S = horizontal flange-stress at any section of the girder,

M = bending moment at the section,

d = total depth of the girder.

Then, in all cases,

$$S = \frac{M}{d}$$

We have, therefore, the following approximate rule for determining the flange-stress at any portion of a H-girder with a thin web.

The flange-stress at any section of a rolled girder is equal to the bending moment at this section, divided by the depth of the girder.

Applying this approximate rule to example 26, we have—

$$M = 936, \quad d = 16.$$

$$\therefore S = \frac{936}{16} = 58.5 \text{ tons.}$$

And, as the sectional area of the flange = 5 square inches, we get stress per square inch on flanges = $\frac{58.5}{5} = 11.7$ tons, instead of 10.24 tons as previously found.

Example 28.—What must be the distance between the supports so that the girder No. 5 in the Table will break by its own weight—(1) in steel; (2) in iron?

Let l = required span in feet.

From the equation—

$$S = \frac{W l}{8 d},$$

we get

$$l = \frac{8 d S}{W}.$$

(1) In the case of steel $W = 53$ lbs. Substituting this in the above equation, we get—

$$l = \frac{8 d S}{53},$$

and as $d = 14$ inches = 1.16 feet and $S = 4.75 \times 30 = 142.5$ tons, or 319,200 pounds, we obtain—

$$l = \frac{8 \times 1.16 \times 319,200}{53},$$

or $l = 237$ feet.

(2) In the case of iron $W = 51.5$ lbs., $d = 1.16$ feet.

$$S = 4.75 \times 20 = 95 \text{ tons} = 212,800 \text{ lbs.}$$

$$l = \frac{8 \times 1.16 \times 212,800}{51.5},$$

$l = 196$ feet.

TABLE XXV.—STRENGTHS OF ROLLED GIRDERS IN WROUGHT IRON AND STEEL.

No.	Depth.	Width of Flange.	Thickness of Web.	Mean Thickness of Flange.	Area in Square Inches.	Weight per foot in lbs.		Moment of Inertia of Section.	Moment of Resistance of Section.		Distributed Breaking Load in Tons on Span of one foot.	
						Iron.	Steel.		Iron.	Steel.	Iron.	Steel.
1	20·0	8·26	·76	·97	29·67	97·2	100	1825	3650	5475	2433	3650
2	18·0	7·10	·71	·94	24·67	81·6	84	1208	2673	4010	1782	2673
3	16·0	6·06	·64	·82	19·15	62·7	64·5	731	1827	2740	1218	1827
4	15·0	5·06	·50	·80	14·88	48·6	50	510	1360	2040	907	1360
5	14·0	5·87	·50	·81	15·76	51·5	53	494	1413	2120	942	1413
6	12·0	6·23	·73	·87	18·45	60·2	62	404	1347	2021	898	1347
7	10·0	6·16	·66	·70	14·27	46·7	48	221·5	886	1329	591	886
8	9·0	3·75	·50	·50	7·74	25·3	26	89·0	396	594	264	396
9	8·0	4·02	·42	·56	7·4	24·3	25	74·2	371	556	247	371
10	7·0	3·70	·32	·46	5·36	17·5	18	42·4	242	364	162	242
11	6·25	3·38	·26	·50	4·76	15·6	16	31·2	200	299	133	200
12	6·0	3·09	·39	·50	5·06	16·5	17	27·5	184	275	122	184
13	5·0	4·35	·35	·58	6·39	20·9	21·5	26·4	211	317	141	211
14	4·0	3·23	·48	·41	4·16	13·6	14·0	9·82	98·2	147	65·5	98·2
15	4·0	1·87	·37	·35	2·53	8·3	8·5	5·5	54·8	82·2	36·5	54·8
16	3·5	2·84	·15	·30	2·68	8·7	9·0	5·7	65·1	97·7	30·3	65·5
17	3·5	1·60	·28	·30	1·78	5·8	6·0	3·04	34·7	52·1	23·2	34·7
18	3·0	2·99	·30	·40	3·05	9·9	10·2	4·34	57·5	86·8	38·3	57·8
19	3·0	1·49	·40	·25	1·75	5·8	6·0	1·94	25·8	38·8	17·2	25·9
20	3·0	1·30	·21	·25	1·19	3·9	4·0	1·52	20·3	30·4	13·5	20·3

CHAPTER XI.

COLUMNS AND LONG STRUTS.

149. **Definition.**—Columns or struts are members of a structure, which are exposed to direct compressive stresses acting in the direction of their lengths. They may be employed in isolated positions, without being connected to other members of the structure, as in the case of ordinary columns supporting the floor of a warehouse, or they may form parts of a braced structure, as, for example, the struts of a lattice girder.

Theoretic Strength of Columns.—The laws which govern the strengths of columns may be investigated theoretically, on purely mathematical principles. This has been done very ably and exhaustively by Euler, Lagrange, Poisson, and others, and the results arrived at are very interesting as specimens of mathematical analysis, though it cannot be said that in all cases they are confirmed by actual experiments.

This theoretic investigation is, to a large extent, founded on certain assumptions regarding the elasticity and other properties of materials which are true only to a limited extent. It, moreover, requires a knowledge on the part of the student of advanced mathematics which, in a treatise like the present, would be altogether out of place. For these reasons it will not be given here, and those who are desirous of studying it exhaustively are referred to Euler's work or to Mr. Fidler's *Treatise on Bridges*.

Practical Rules.—Theoretical rules as applied to determine the strength of structures, though very valuable, are not to be relied upon unless they are confirmed by the tests of practical experience.

The rules for determining the strength of columns which will be given here are altogether *empirical*; and the experiments from which they are deduced have been very numerous and conducted with a great deal of care.

It is to the late Mr. Hodgkinson that we are principally indebted for the knowledge we possess on the subject. He made exhaustive experiments on pillars of cast iron, wrought iron, steel, and timber, of different lengths and sections, from which it appears that so far as the *design* of a column is concerned, its strength depends mainly on two considerations:—

1st. On the proportion which the length of the column bears to its shortest diameter.

2nd. Upon the form of, and the method of, fixing the ends.

As regards the first consideration, columns may be divided into three classes, viz. :—

Short columns.

Long columns.

Medium columns.

150. **Short Columns** are those which fail by the actual crushing of the material of which they are composed. The relative proportion of the length to the least diameter of columns belonging to this class varies with the nature of the material. When made of cast iron, this proportion should not be greater than four or five to one. For wrought iron and steel the proportion may be somewhat greater, while for timber it may be as high as ten and even twelve to one.

I. CAST-IRON COLUMNS.

151. **Long Columns**—Mr. Hodgkinson applies the term “long column” to one (when made of cast iron) whose length is at least 30 times its diameter, both ends being flat. If both ends be rounded the term will apply to those whose lengths are 15 diameters and upwards. It is important to bear this distinction in mind, for, as will presently be seen, the *form* of the ends of a column has a great deal to do with its strength.

Long columns, unlike short ones, do not fail by direct compression, their failure being produced by bending or cross fracture, in a manner very similar to beams acted upon by a transverse stress. The direct breaking weight of columns of this class is far less than the actual crushing strength of the material of which they are composed. Certain rules and formulæ have been given by Hodgkinson, Gordon, and others for determining their strength, which will be given later on.

152. **Columns of Medium Length**.—Columns classified under this head are those in which the ratio of the length to the diameter is a mean between that which exists in short and long columns. All those with flat and square ends whose lengths are less than 30 and more than 5 diameters; and all with both ends rounded whose lengths are less than 15 diameters belong to this class. Columns of medium length fail partly by flexure and partly by crushing.

Experiments show that in long solid columns those with flat ends are approximately three times as strong as similar ones with rounded ends, and also that the strengths of those with discs cast on their ends are nearly the same as those of the same diameter with rounded ends but only half the length.

The strength of solid cast-iron columns with one end rounded and the other flat is approximately a mean between those of the same length and diameter with both ends flat and those with both ends rounded, so that the strengths of these three classes are in the proportion 1 : 2 : 3.

These rules also apply when the material is wrought iron, steel, or timber.

Figs. 84, 85, and 86 represent columns of these three classes whose lengths and diameters are the same. Their tendency to deflect will be in the manner shown. The breaking weight of 85 is *twice* and of 86 *three times* that of 84.

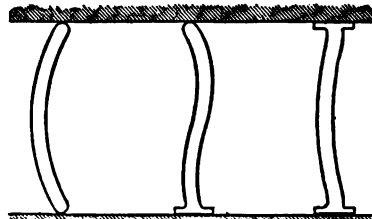

Figs. 84, 85, 86.

153. Position of Fracture in Long Cast-Iron Columns.—From his experiments on long columns, Mr. Hodgkinson found that when they were the same at both ends—that is, either when both ends were flat, or both ends rounded—fracture took place in the middle of the column or near to it. When one end was flat and the other rounded the column broke at some point near the rounded end, the piece broken off being always a little more than one-third of the whole length.

In the case of *round* columns of *solid* section with similar ends and which always broke near the middle, their strengths (as was to be expected) were increased by increasing the diameter at the middle; the increase in strength being about one-seventh more than in parallel columns of the same weight; and being most marked in those with rounded ends. In the case of columns with discs cast on the ends, the increase of strength is not so great.

The strength of a flat-ended column depends a good deal on the manner in which its ends are fixed. In ordinary practice such columns have discs cast on their ends, and if these discs are not quite level and square with its length, there is a tendency for the load to be transmitted diagonally or unequally along the column. In order to prevent this, it is usually the custom of

engineers in drawing up their specifications to direct that the bases and tops be faced in the lathe, and also that the stones or other foundations on which they rest be dressed off level. As an additional precaution, it is often specified that a sheet of lead or felt be inserted between the base of the column and the stone on which it rests.

When these precautions are not adopted, liquid cement should be run in between the base and the top of the stone after the column has been fixed truly vertical in its place; by this means all crevices are filled up, and when the cement solidifies it is very hard and durable. Cases have come under the author's observation where large cast-iron columns carrying heavy loads have not only fractured the stones on which they rested, but also had their own bases cracked owing to unequal bedding.

154. Rules for Determining the Strength of Long Cast-Iron Columns either Solid or Hollow, and Circular in Section.—In the elaborate theoretical researches of Euler, he proceeded on the assumption that the strength of a column was proportional to its power of resisting bending. He found that in long columns their strengths were *directly* proportional to the fourth power of their diameters and *inversely* to the squares of their lengths, so that if

d = diameter of a solid column,

l = length " "

the strength will vary as $\frac{d^4}{l^2}$.

In the same way, if d_1, d_2 be the external and internal diameters of a hollow column of length l , its strength will be proportional to $\frac{d_1^4 - d_2^4}{l^2}$.

The correctness of this conclusion has not been established by the experiments of Hodgkinson. He found that with long cast-iron columns whose ends were flat and well bedded, their strengths varied directly as the 3.5th power of their diameter, and inversely as the 1.63rd power of their lengths.

Let W = breaking weight of the column in tons,

l = length of the column in feet,

d = diameter " inches,

m = a coefficient which varies with the quality of the iron.

Hodgkinson's formula for long columns of solid cylindrical section is—

$$W = m \cdot \frac{d^{3.5}}{l^{1.63}} \quad . \quad . \quad . \quad (1).$$

For hollow cylindrical columns whose external and internal diameters are d_1 and d_2 respectively—

$$W = m \cdot \frac{d_1^{3.5} - d_2^{3.5}}{l^{1.63}} \quad . \quad . \quad . \quad (2).$$

From a number of experiments on columns made of 13 different kinds of cast iron, the mean values of m were found to be as follows :—

- (1) For solid columns with flat ends, . . . $m=44.16$.
- (2) For solid columns with rounded ends, . . . $m=14.9$.
- (3) For hollow columns with flat ends, . . . $m=44.34$.
- (4) For hollow columns with rounded ends, . . . $m=13.00$.

Substituting these values of m in equations (1) and (2) we get the following :—

For solid columns with flat ends, . . . $W = 44.16 \frac{d^{3.5}}{l^{1.63}} \quad . \quad . \quad (3).$

For solid columns with rounded ends, $W = 14.9 \frac{d^{3.5}}{l^{1.63}} \quad . \quad . \quad (4).$

For hollow columns with flat ends, . . . $W = 44.34 \frac{d_1^{3.5} - d_2^{3.5}}{l^{1.63}} \quad . \quad (5).$

For hollow columns with rounded ends, $W = 13 \frac{d_1^{3.5} - d_2^{3.5}}{l^{1.63}} \quad . \quad (6).$

It must be borne in mind that equations (1) and (2) apply not only to columns with flat ends whose lengths exceed 30 diameters, but also to columns with rounded ends whose lengths exceed 15 diameters.

TABLE XXVI.—THE 3·5TH POWER OF THE DIAMETERS, OR $d^{3.5}$.

1·0 ^{3.5} = 1·00	3·7 ^{3.5} = 97·43	5·6 ^{3.5} = 415·58	7·5 ^{3.5} = 1155·35
1·25 ^{3.5} = 2·18	3·75 ^{3.5} = 102·12	5·7 ^{3.5} = 442·14	7·6 ^{3.5} = 1210·17
1·5 ^{3.5} = 4·13	3·8 ^{3.5} = 106·96	5·75 ^{3.5} = 455·87	7·7 ^{3.5} = 1266·83
1·75 ^{3.5} = 7·09	3·9 ^{3.5} = 117·15	5·8 ^{3.5} = 469·89	7·75 ^{3.5} = 1295·85
2·0 ^{3.5} = 11·31	4·0 ^{3.5} = 128·00	5·9 ^{3.5} = 498·86	7·8 ^{3.5} = 1325·35
2·1 ^{3.5} = 13·42	4·1 ^{3.5} = 139·55	6·0 ^{3.5} = 529·09	7·9 ^{3.5} = 1385·78
2·2 ^{3.5} = 15·79	4·2 ^{3.5} = 151·83	6·1 ^{3.5} = 560·60	8·0 ^{3.5} = 1448·15
2·25 ^{3.5} = 17·09	4·25 ^{3.5} = 158·26	6·2 ^{3.5} = 593·43	8·25 ^{3.5} = 1612·83
2·3 ^{3.5} = 18·45	4·3 ^{3.5} = 164·87	6·25 ^{3.5} = 610·35	8·5 ^{3.5} = 1790·47
2·4 ^{3.5} = 21·42	4·4 ^{3.5} = 178·68	6·3 ^{3.5} = 627·61	8·75 ^{3.5} = 1981·66
2·5 ^{3.5} = 24·70	4·5 ^{3.5} = 198·30	6·4 ^{3.5} = 663·18	9·0 ^{3.5} = 2187·00
2·6 ^{3.5} = 28·34	4·6 ^{3.5} = 208·76	6·5 ^{3.5} = 700·16	9·25 ^{3.5} = 2407·11
2·75 ^{3.5} = 34·49	4·7 ^{3.5} = 225·08	6·6 ^{3.5} = 738·59	9·5 ^{3.5} = 2642·61
2·8 ^{3.5} = 36·73	4·75 ^{3.5} = 233·58	6·7 ^{3.5} = 778·51	9·75 ^{3.5} = 2894·12
2·9 ^{3.5} = 41·53	4·8 ^{3.5} = 242·29	6·75 ^{3.5} = 799·03	10·0 ^{3.5} = 3162·28
3·0 ^{3.5} = 46·76	4·9 ^{3.5} = 260·43	6·8 ^{3.5} = 819·94	10·25 ^{3.5} = 3447·73
3·1 ^{3.5} = 52·45	5·0 ^{3.5} = 279·51	6·9 ^{3.5} = 862·92	10·5 ^{3.5} = 3751·13
3·2 ^{3.5} = 58·62	5·1 ^{3.5} = 299·57	7·0 ^{3.5} = 907·49	10·75 ^{3.5} = 4073·14
3·25 ^{3.5} = 61·88	5·2 ^{3.5} = 320·63	7·1 ^{3.5} = 953·68	11·0 ^{3.5} = 4414·43
3·3 ^{3.5} = 65·28	5·25 ^{3.5} = 331·56	7·2 ^{3.5} = 1001·53	11·25 ^{3.5} = 4775·66
3·4 ^{3.5} = 72·47	5·3 ^{3.5} = 342·74	7·25 ^{3.5} = 1026·08	11·5 ^{3.5} = 5157·54
3·5 ^{3.5} = 80·21	5·4 ^{3.5} = 365·91	7·3 ^{3.5} = 1051·07	11·75 ^{3.5} = 5560·74
3·6 ^{3.5} = 88·52	5·5 ^{3.5} = 390·18	7·4 ^{3.5} = 1102·33	12·0 ^{3.5} = 5985·96

TABLE XXVII.—THE 1·63RD POWER OF THE LENGTHS, OR $l^{1·63}$.

$1^{1·63} = 1·00$	$7^{1·63} = 23·85$	$13^{1·63} = 65·42$	$19^{1·63} = 121·44$
$2^{1·63} = 3·09$	$8^{1·63} = 29·65$	$14^{1·63} = 73·82$	$20^{1·63} = 132·03$
$2·5^{1·63} = 4·45$	$9^{1·63} = 35·92$	$15^{1·63} = 82·61$	$21^{1·63} = 142·96$
$3^{1·63} = 5·99$	$10^{1·63} = 42·66$	$16^{1·63} = 91·77$	$22^{1·63} = 154·22$
$4^{1·63} = 9·58$	$11^{1·63} = 49·83$	$17^{1·63} = 101·30$	$23^{1·63} = 165·81$
$5^{1·63} = 13·78$	$12^{1·63} = 57·42$	$18^{1·63} = 111·20$	$24^{1·63} = 177·72$
$6^{1·63} = 18·55$			

Example 1.—What is the breaking weight of a solid cylindrical column of cast iron whose length is 20 feet and diameter 6 inches; the ends being flat and well bedded?

From equation (3) we get, by substitution,

$$W = 44·16 \times \frac{6^{3·5}}{20^{1·63}} = 44·16 \times \frac{529·09}{132·03} = 176·9 \text{ tons.}$$

Example 2.—A hollow cylindrical cast-iron pillar is 24 feet long, and its external and internal diameters are 9 inches and 7 inches respectively. Calculate its breaking weight, its ends being flat and well bedded.

From equation (5)

$$W = 44·34 \times \frac{9^{3·5} - 7^{3·5}}{24^{1·63}} = 44·34 \times \frac{2187 - 907·49}{177·72} = 319·4 \text{ tons.}$$

Hodgkinson's formulæ are not well adapted for determining the strengths of pillars unless we have a table of 3·5th and 1·63rd powers. In case such a table is not at hand it will be necessary to have recourse to a table of logarithms.

In equation (1), if W and l be known d may be found, or if W and d be known l may be found.

By transposing the members of the equation we get—

$$d^{3·5} = W \cdot \frac{l^{1·63}}{m}, \text{ or } d = \sqrt[3·5]{W \cdot \frac{l^{1·63}}{m}}.$$

From which we get

$$\log d = \frac{\log W + 1·63 \log l - \log m}{3·5} \quad (7).$$

By means of this equation the diameter of a solid cylindrical column may be found when its breaking weight and length are known. In the same way it may be shown that

$$l = \sqrt[1.63]{m \cdot \frac{d^{3.5}}{W}},$$

or

$$\log l = \frac{\log m + 3.5 \log d - \log W}{1.63} \quad (8),$$

which gives an expression for the length of a solid cylindrical pillar whose breaking weight and diameter are known.

Example 3.—What will be the diameter of a solid cylindrical cast-iron pillar 10 feet long whose breaking weight is 40 tons, the ends being flat?

$$\begin{aligned} W &= 40. & \log W &= 1.6020. \\ l &= 10. & \log l &= 1. \\ m &= 44.16. & \log m &= 1.6450. \end{aligned}$$

Substituting these values in equation (7) we obtain—

$$\begin{aligned} \log d &= \frac{\log 40 + 1.63 \log 10 - \log 44.16}{3.5} \\ &= \frac{1.6020 + 1.63 - 1.6450}{3.5} = 0.4534 \end{aligned}$$

$$\therefore d = 2.8 \text{ inches.}$$

Example 4.—A solid cast-iron cylindrical pillar with both ends rounded, and whose diameter is 3 inches, fails with a load of $5\frac{1}{2}$ tons. What is its length?

$$\begin{aligned} W &= 5.5 \text{ tons.} & \log 5.5 &= 0.7403. \\ d &= 3. & \log 3 &= 0.4771. \\ m &= 14.9. & \log 14.9 &= 1.1732. \end{aligned}$$

By substitution in equation (8) we get—

$$\log l = \frac{\log 14.9 + 3.5 \log 3 - \log 5.5}{1.63} = 1.2536$$

$$\therefore l = 19.5 \text{ feet.}$$

The external and internal diameters and also the lengths of

hollow cylindrical columns may be found by transposing the members of equation (2). Thus—

$$d_1^{3.5} = d_2^{3.5} + W \cdot \frac{l^{1.68}}{m}, \text{ or } d_1 = \left(d_2^{3.5} + W \frac{l^{1.68}}{m} \right)^{\frac{1}{3.5}} \quad (9).$$

$$d_2^{3.5} = d_1^{3.5} - W \frac{l^{1.68}}{m}, \text{ or } d_2 = \left(d_1^{3.5} - W \frac{l^{1.68}}{m} \right)^{\frac{1}{3.5}} \quad (10).$$

$$l^{1.68} = \frac{m}{W} (d_1^{3.5} - d_2^{3.5}), \text{ or } l = \left\{ \frac{m}{W} (d_1^{3.5} - d_2^{3.5}) \right\}^{\frac{1}{1.68}} \quad (11).$$

The values of d_1 , d_2 , and l may be found from equations (9), (10), and (11) with the aid of a table of logarithms.

155. Strength of Columns of Medium Length.—A column of medium length, as has been explained, is one whose length varies between 5 and 30 times its diameter when applied to those with flat ends. Columns of this class fail partly by crushing and partly by bending, and the formulæ given for long columns do not apply to them. Mr. Hodgkinson has, from his experiments, deduced the following formula for the strength of medium pillars :—

$$W_1 = \frac{Wc}{W + \frac{1}{4}c} \quad (12).$$

Where W_1 = breaking weight of the medium column in tons,
 W = breaking weight in tons as calculated from equations (1) or (2),
 c = sectional area of the columns multiplied by the crushing weight of the material.

Example 5.—What is the breaking weight of a solid column of cast iron 10 feet long and $7\frac{1}{2}$ inches in diameter, the ends being flat and well bedded, and the crushing strength of the iron being 40 tons per square inch.

From equation (3) we get—

$$W = 44.16 \frac{(7.5)^{3.5}}{10^{1.68}} = 44.16 \times \frac{1155.35}{42.66} = 1,196 \text{ tons.}$$

This would be the breaking weight on the assumption that the column failed by flexure alone. Sectional area of column = 44.17 square inches, hence—

$$c = 44.17 \times 40 = 1766.8 \text{ tons.}$$

By substitution in equation (12) we get—

$$W_1 = \frac{1196 \times 1766 \cdot 8}{1196 + 1325} = 838 \text{ tons,}$$

which is the required breaking weight.

156. Safe Working Load on Cast-iron Columns.—The factor of safety to be used for columns cannot be fixed on any hard and fast lines as a number of considerations have to be taken into account. Generally speaking, for those made of cast iron and exposed to steady loads, $\frac{1}{3}$ th of the breaking weight may be considered as a safe working load, provided that proper precautions be taken to make the column bed properly, but even then it is not often advisable to load them to a greater extent than $\frac{1}{10}$ th of their breaking load.

If the columns be exposed to loads of a vibratory character the margin of safety should be still greater, varying from $\frac{1}{2}$ th to $\frac{1}{20}$ th of the breaking weight. We have, therefore, the following rules for the factor of safety for cast-iron columns:—

1st. For steady loads the factor of safety should vary from 6 to 10.

2nd. For vibratory loads it should vary from 12 to 20.

Example 6.—What is the safe stationary load which may be applied in practice to a hollow cast-iron column (of the same quality of iron as in example 5) 12 feet long, the external diameter being 8 inches and the thickness of metal being 1 inch, and the ends well bedded?

$$d_1 = 8 \text{ inches,} \quad d_2 = 6 \text{ inches,} \quad l = 12 \text{ feet.}$$

From equation (5) we get—

$$W = 44 \cdot 34 \times \frac{8^{3 \cdot 5} - 6^{3 \cdot 5}}{12^{1 \cdot 68}} = 44 \cdot 34 \times \frac{1448 \cdot 15 - 529 \cdot 09}{57 \cdot 42} = 709 \text{ tons.}$$

Sectional area of column = 22 square inches,

$$c = 22 \times 40 = 880 \text{ tons.}$$

$$\text{The breaking weight } W_1 = \frac{709 \times 880}{709 + 660} = 456 \text{ tons.}$$

The safe load in ordinary practice may be taken as $\frac{1}{10}$ th of this or 45.6 tons.

157. Proportions of Hollow Cast-iron Columns.—There is no rule to guide us in determining the best proportions between the lengths and diameters of columns; several considerations have to be taken into account in fixing this. The relative pro-

portion depends mainly on the load which has to be carried. It depends also on the space which the column takes up. Plenty of room in a building is often a great desideratum, and when so, the smaller the diameter the better. There is also the question of appearance and the harmony produced by comparing the column with its surroundings.

It is not often that the length is made more than 30 times the diameter. For warehouses and buildings in general, the length varies between 12 and 25 times the diameter. Columns for supporting bridges and other heavy structures are often of a much larger proportionate diameter, it sometimes being as much as one-sixth of the length.

As regards the thickness of metal in hollow columns a recognised practical rule is that in no case should the thickness be made less than one-twelfth of the diameter. It may vary between this and one-sixth.

General Morin recommends the following rules :—

For columns from 7 to 10 feet long the maximum thickness should be	7 to 10	10 to 13	13 to 20	20 to 27	27 to 30	30 to 35	35 to 40
	5 in.	6 in.	8 in.	10 in.	12 in.	14 in.	16 in.

The old foundry practice, and which is even now very largely followed, is to cast pillars in a horizontal position. There are objections to this, as it is not often easy to keep the core central, which leads to the fault of getting the metal thicker on one side than the other. When this happens unequal strains are produced in the body of the casting as it cools, and this has a tendency to make the column crooked and may even produce fracture.

The modern practice, and much the better one, is to cast the column vertically in the sand with a head of metal. By doing this the uniformity in the thickness of the metal is better preserved, while the pressure from the head of metal tends to drive out air and gas bubbles which make the casting honeycombed.

Mr. Hodgkinson remarks that "In experiments upon hollow pillars it is frequently found that the metal on one side is much thinner than on the other; but this does not produce so great a diminution in the strength as might be expected, for the thinner part of the casting is much harder than the thicker, and this usually becomes the compressed side."

It is a common practice for inspectors of ironwork to have small holes drilled at different portions of the column, so that its thickness may be gauged. If the thickness at any portion be as much as 25 per cent. less than that specified the casting should be rejected.

158. Columns of + and H-Sections.—The most common form for columns made of cast iron is that of a hollow cylinder, but those of the + and H-sections are also much used. The H-section is often employed in mills and other works, not because of its appearance or strength, but for the reason that its shape readily lends itself for the fixing of brackets for shafting, &c. An advantage which both this and the cruciform section possess over the hollow cylinder is, that if any defects occur in the casting they are more easily discovered. Columns of these sections, for the same weight, are not nearly so strong as hollow cylindrical ones, so that from this point of view they are not so economical as the latter.

Their relative strengths are as follows:—

Hollow cylindrical column, . . .	100
H-shaped " . . .	75
+ -shaped " . . .	44

The relative strengths of long solid pillars of round, square, and triangular sections, the columns being of the same weight and length, are:—

Long solid round columns, . . .	100
" square " . . .	93
" triangular , , . . .	110

159. Gordon's Rules for Columns.—The various formulæ given by Mr. Hodgkinson, though very valuable and reliable, cannot be said to be in a form easily adapted for calculations, and for this reason will never become popular with the engineer. As has been already explained, they require the aid of a table of logarithms, which is not always at hand; besides, it makes calculations a laborious matter. For this reason several attempts have been made to embody these rules in forms more convenient for calculation. This has been done most successfully by Mr. Lewis Gordon, whose formula we will now give.

Let P = breaking load of a column in tons,

S = number of square inches of sectional area of column,

r = ratio of length to least diameter,

f and a = constants which depend on the material and the section of the column;

then
$$P = \frac{fS}{1 + ar^2} \cdot \cdot \cdot \cdot (13),$$

for columns with both ends flat and fixed ;

and
$$P = \frac{fS}{1 + 4 a r^2} (14),$$

for columns rounded or jointed at ends.

The values of the constants are :—

For round, solid, or hollow cast-iron columns,

$$f = 36 \text{ tons}, \quad a = \frac{1}{400};$$

For solid and hollow rectangular columns,

$$f = 36 \text{ tons}, \quad a = \frac{1}{500}.$$

The student will find it a profitable exercise to calculate the strengths of different columns, both by Hodgkinson's and Gordon's rules, and see how far the results agree.

Example 7.—Find by Gordon's rule the breaking weight of the column in example (1).

$$S = \text{area of section} = 28 \cdot 27 \text{ square inches,}$$

$$r = \frac{240}{6} = 40.$$

Substituting these values in equation (13), and putting for f and a their proper values, we get—

$$P = \frac{36 \times 28 \cdot 27}{1 + \frac{(40)^2}{400}} = 203 \cdot 5 \text{ tons.}$$

The breaking weight according to Hodgkinson's rule is 177 tons, which shows a considerable discrepancy.

If the ends are imperfectly fixed, we get from Gordon's formula (14)—

$$P = \frac{36 \times 28 \cdot 27}{1 + \frac{(40)^2}{100}} = 59 \cdot 8 \text{ tons.}$$

From Hodgkinson's rule—

$$\text{Breaking weight} = 14 \cdot 9 \times \frac{6^{35}}{20^{1.33}} = 59 \cdot 7 \text{ tons.}$$

These results agree very nearly.

Example 8.—Apply Gordon's formula to determine the breaking weight of the column given in example 2.

$$S = \frac{\pi}{4} \{(9)^2 - (7)^2\} = 25 \cdot 13 \text{ square inches.}$$

$$r = \frac{288}{9} = 32.$$

From equation (13)—

$$P = \frac{36 \times 25 \cdot 13}{1 + \frac{(32)^2}{400}} = 254 \text{ tons,}$$

as against 319 tons as found by Hodgkinson's rule.

Example 9.—Apply Gordon's formula to find the diameter of the pillar given in example 3.

Let d = required diameter,

$$\text{Then } S = \cdot 7854 d^2, \quad r = \frac{120}{d}.$$

$$P = 40.$$

Substituting in equation (13) we get—

$$40 = \frac{36 \times \cdot 7854 d^2}{1 + \frac{(120)^2}{400 d^2}} = \frac{28 \cdot 27 d^4}{d^2 + 36}.$$

$$28 \cdot 27 d^4 - 40 d^2 - 1,440 = 0.$$

Solving this quadratic equation, we get—

$$\begin{aligned} d^2 &= 7 \cdot 9 \text{ inches,} \\ d &= 2 \cdot 81 \text{ inches,} \end{aligned}$$

which agrees very nearly with the diameter as found by Hodgkinson's rule.

Example 10.—Find the length of the pillar in example 4 by the aid of Gordon's rule.

Let l = required length, d = diameter.

Substituting in equation (14) we get—

$$P = \frac{f S}{1 + 4 a \cdot \frac{l^2}{d^2}}$$

From this equation, solving for l , we find—

$$l = \frac{d}{2} \sqrt{\frac{fS - P}{Pa}}$$

Putting $d = 3$, $S = .7854 \times 9 = 7.068$,

$$P = 5.5, \quad f = 36, \quad a = \frac{1}{400}$$

19.5 we get $l = 201.9$ inches = 16.8 feet,
as against 18 feet, as found by Hodgkinson's rule.

Example 11.—What is the breaking weight of a solid cast-iron pillar, 12 feet long and 4 inches square; the ends being securely fixed?

Applying equation (13) we have the following values:—

$$f = 36. \quad S = 16. \quad a = \frac{1}{500}. \quad r = \frac{144}{4} = 36.$$

Hence, by substitution, we get—

$$P = \frac{36 \times 16}{1 + \frac{(36)^2}{500}} = 160.4 \text{ tons.}$$

If the pillar have rounded ends

$$P = \frac{36 \times 16}{1 + 4 \times \frac{(36)^2}{500}} = 50.6 \text{ tons.}$$

Example 12.—What is the breaking weight of a solid rectangular cast-iron pillar 10 feet long, its section being 3 inches by 2 inches, and ends fixed?

In this case $S = 3 \times 2 = 6$. $r = \frac{120}{2} = 60$.

$$P = \frac{36 \times 6}{1 + \frac{(60)^2}{500}} = 26.3 \text{ tons.}$$

Example 13.—A solid cast-iron pillar of rectangular section, 4 inches by 3 inches, breaks with a weight of 60 tons when its ends are properly fixed; determine its length.

Let l = required length; if d = least diameter, $r = \frac{l}{d}$.

From equation (13) we obtain—

$$l = d \sqrt{\frac{f S - P}{P a}}$$

Putting $d = 3$, $S = 4 \times 3 = 12$, $P = 60$, $f = 36$, $a = \frac{1}{500}$, we get—

$$l = 167.1 \text{ inches} = 13.9 \text{ feet.}$$

TABLE XXVIII.—BREAKING WEIGHT IN TONS PER SQUARE INCH OF SOLID OR HOLLOW CAST-IRON COLUMNS, THE ENDS BEING SECURELY FIXED.

Length of Column in diameters	Breaking Weight in Tons per square inch.		Length of Column in diameters	Breaking Weight in Tons per square inch.	
	HODGKINSON.	GORDON.		HODGKINSON.	GORDON.
5	...	33.9	19	20.1	19.0
6	...	33.0	20	19.1	18.0
7	...	32.0	21	18.2	17.1
8	...	31.0	22	17.4	16.3
9	...	30.0	23	16.5	15.5
10	33.1	28.8	24	15.7	14.6
11	31.3	27.6	25	15.1	14.1
12	29.6	26.5	26	14.5	13.4
13	28.0	25.3	27	13.9	12.8
14	26.5	24.2	28	13.2	12.1
15	25.0	23.0	29	12.5	11.6
16	23.7	22.0	30	11.8	11.0
17	22.5	20.9	33	10.0	9.7
18	21.8	19.9			

Example 14.—What must be the section of a square column, 15 feet long, so as just to fail with a load of 100 tons; its ends being fixed?

If d = side of the square and l = length, from equation (13) we get—

$$P = \frac{f d^4}{d^2 + a l^2}, \text{ or } f d^4 - P d^2 - P a l^2 = 0.$$

By substituting for f , P , a , and l , their proper values, we get—

$$\begin{aligned} 36 d^4 - 100 d^2 - 6,480 &= 0, \\ d^2 &= 14.88, \\ d &= 3.86 \text{ inches.} \end{aligned}$$

160. Rankine's Rules for the Strength of Columns.—The late Professor Rankine has given rules for calculating the strengths of columns and struts which are expressed in terms of the least radius of gyration of the section; these rules are of the greatest importance, and the following is a summary taken from his *Useful Rules and Tables*:—

Let P = breaking load of the column,
 S = sectional area " "
 l = length " "
 r = least radius of gyration of its cross-section,
 f and c = coefficients whose value depends on the nature of the material.

1st. For a column fixed at both ends

$$P = \frac{f \cdot S}{1 + \frac{l^2}{c r^2}} \quad \dots \quad (15).$$

2nd. For a column with both ends rounded or jointed

$$P = \frac{f \cdot S}{1 + \frac{4 l^2}{c r^2}} \quad \dots \quad (16).$$

3rd. For a column with one end fixed and the other rounded or jointed

$$P = \frac{f \cdot S}{1 + \frac{16 l^2}{9 c r^2}} \quad \dots \quad (17).$$

The following are the values of the constants f and c :—

	f	c
	lbs. per square inch.	
Cast iron,	80,000	3,200
Wrought iron,	36,000	36,000
Dry timber,	7,200	2,000

Definition.—The square of the radius of gyration of a surface about a given axis is equal to the moment of inertia of the surface about the axis divided by its area.

Let r = radius of gyration of the surface,
 I = moment of inertia " "
 A = area of the surface.

Then—

$$r^2 = \frac{I}{A}.$$

TABLE XXIX.—VALUES OF r^2 FOR DIFFERENT FORMS OF CROSS-SECTION.

FORM OF SECTION.	$r^2 = \frac{I}{A}$.
Solid square side = b ,	$\frac{b^2}{12}$
Solid rectangle least side = a ,	$\frac{a^2}{12}$
Rectangular cell breadths b and b_1 , depths d and d_1 ,	$\frac{b d^3 - b_1 d_1^3}{12 (b d - b_1 d_1)}$
Square cell sides b and b_1 ,	$\frac{b^2 + b_1^2}{12}$
Solid cylinder diameter = d ,	$\frac{d^2}{16}$
Hollow cylinder diameters d and d_1 ,	$\frac{d^2 + d_1^2}{16}$
Angle iron of equal ribs, breadth of each = b ,	$\frac{b^2}{12}$
Angle iron of unequal ribs, greater = b , less = h ,	$\frac{b^2 h^2}{12 (b^2 + h^2)}$

II. WROUGHT-IRON COLUMNS AND STRUTS.

Columns made of wrought iron are much more reliable than those made of cast iron. All risk of flaws, blow-holes, shifting of cores, and irregularity in section are avoided; and they possess

the further advantage (which is a very important one when used in buildings) of being better able to resist the attacks of fire.

The rules which regulate their strength are very similar to those which apply to cast-iron columns.

161. Wrought-iron Columns of Solid Section.—The strength of solid rectangular columns may be found from Gordon's formulæ by giving to the constants f and a the following values :—

$$f = 16 \text{ tons}, \quad a = \frac{1}{3,000}.$$

Example 15.—What is the breaking weight of a solid pillar of wrought iron 20 feet long and 6 inches square ?

$$l = 240, \quad d = 6, \quad S = 36, \quad r = 40.$$

From equation (13)—

$$P = \frac{16 \times 36}{1 + \frac{(40)^2}{3,000}} = 375.6 \text{ tons.}$$

If both ends are rounded—

$$P = \frac{16 \times 36}{1 + 4 \frac{(40)^2}{3,000}} = 183.8 \text{ tons,}$$

which is about one-half of the former.

Example 16.—What must be the section of a solid square pillar of wrought iron, 15 feet long, whose breaking weight is 50 tons; the ends being fixed ?

Let d = side of the square in inches,

$$S = d^2, \quad l = 180, \quad P = 50.$$

From equation (13)—

$$50 = \frac{16 d^2}{1 + \frac{1}{3,000} \times \frac{(180)^2}{d^2}}.$$

Reducing, we get—

$$8 d^4 - 25 d^2 = 270; \quad d^2 = 7.6, \quad \text{or} \quad d = 2.75 \text{ inches.}$$

Example 17.—If the breaking load of a solid rectangular wrought-iron pillar, 10 feet long and 2 inches in thickness, be

30 tons—What will be the width of the pillar if its ends be imperfectly fixed?

Let x = required width,

$$S = 2x, \quad l = 120, \quad r = 60, \quad P = 30.$$

From equation (14), we get—

$$30 = \frac{16 \times 2x}{1 + 4 \cdot \frac{(60)^2}{3,000}}$$

From which we get

$$x = 5.4 \text{ inches.}$$

162. Rankine's Rules for Wrought-iron Columns.—Rankine's rules, given in equations (15), (16), and (17), may be applied for determining the strengths of wrought-iron columns and struts of any section, by giving to the constants the following values:—

$$f = 36,000 \text{ lbs.}, \quad c = 36,000.$$

These rules might be applied to solve examples 15, 16, and 17. For example, in 15 we get—

$$r^2 = \frac{(6)^2}{12} = 3.$$

$$P = \frac{36,000 \times 36}{1 + 36,000 \times 3 \cdot \frac{(240)^2}{3,000}} = 377.3 \text{ tons,}$$

when both ends are fixed, which agrees very nearly with the result as found by Gordon's formula.

When both ends are rounded

$$P = \frac{36,000 \times 36}{1 + 4 \cdot \frac{(240)^2}{3,600 \times 3}} = 184.8 \text{ tons.}$$

When one end is fixed and the other rounded

$$P = \frac{36,000 \times 36}{1 + 9 \cdot \frac{(240)^2}{3,600 \times 3}} = 297 \text{ tons.}$$

This latter is rather more than a mean between the first two.

163. Solid Round Wrought-iron Columns.—The strengths of solid round wrought-iron columns per square inch of section is less than that of similar solid square columns. Rankine's formula may be applied for determining these strengths.

Example 18.—What is the breaking weight of a solid round wrought-iron column, 2 inches in diameter and 7·5 feet long ?

1. When both ends are fixed.
2. When both ends are jointed.
3. When one end is fixed and the other jointed.

$$S = 3 \cdot 1416, \quad r^2 = \frac{(2)^2}{16} = \frac{1}{4}, \quad l = 90 \text{ inches.}$$

1. By substitution in equation (15) we get—

$$P = \frac{36,000 \times 3 \cdot 1416}{1 + \frac{(90)^2}{36,000 \times \frac{1}{4}}} = 26 \cdot 5 \text{ tons.}$$

2. From equation (16) we get—

$$P = \frac{36,000 \times 3 \cdot 1416}{1 + 4 \frac{(90)^2}{36,000 \times \frac{1}{4}}} = 10 \cdot 9 \text{ tons.}$$

3. From equation (17) we have—

$$P = \frac{36,000 \times 3 \cdot 1416}{1 + \frac{16}{9} \cdot \frac{(90)^2}{36,000 \times \frac{1}{4}}} = 19 \cdot 4 \text{ tons.}$$

164. Wrought-iron Tubular Columns.—From experiments made by Messrs. Fairbairn and Clark on wrought-iron tubular columns, it appears that, within certain limits, their strength per square inch of sectional area is independent of their length. For columns whose length does not exceed 30 times the least breadth, the failure takes place, not by the bending of the column as a whole, but by the buckling of the plates in short lengths. This buckling of course would not have taken place if the plates were thick or properly stiffened. The crushing strength per square inch of a long tubular column depends mainly on two considerations:—

1. On its diameter or least breadth compared with its length,
2. On the thickness of the plates compared with its diameter.

Generally speaking, as appears from Table XXX., the unit strength appears to be greater, the thicker the plate is compared with the diameter of the tube. It will also be seen from the table, that in most cases when the proportion of the dia-

meter to the thickness of the sides is less than 50, the breaking weight per square inch of sectional area exceeds 10 tons, though there are some exceptions.

TABLE XXX.*—EXPERIMENTS ON WROUGHT-IRON HOLLOW CYLINDRICAL COLUMNS.

Length.	Diameter.	Thickness of Plates.	Sectional Area.	Ratio of Length to Diameter.	Ratio of Diameter to thickness of Metal.	Breaking Weight.	Breaking Weight per sq. in. of Section.
Feet.	Inches.	Inch.	Sq. Ins.			Tons.	Tons.
10	1·495	·101	·444	80	15	2·9	6·55
5	1·495	40	15	6·18	13·92
2·5	20	15	6·78	15·27
10	1·964	·104	·61	60	18·8	6·32	10·36
5	30·5	18·8	9·07	14·86
2·5	15·3	18·8	10·07	16·51
10	2·49	·107	·804	47·8	23·27	10·69	13·3
5	24·1	...	12·6	15·67
2·5	21·0	...	13·1	16·29
10	2·35	·242	1·605	51·0	9·7	15·4	9·63
2·5	2·38	·246	1·65	12·5	9·7	24·4	14·78
10	3·0	·15	1·35	40·0	20·0	16·67	12·35
7·5	3·03	·168	1·41	29·6	18·0	18·8	13·3
2·3	3·0	·153	1·41	9·3	19·6	23·6	16·7
10	4·05	·14	1·70	29·6	29·0	21·07	12·34
7·5	4·05	·121	1·61	22·2	30·9	24·0	14·88
10	4·06	·155	1·9	29·6	26·1	22·27	11·72
10	6·36	·13	2·54	18·9	49·0	40·80	16·06
7·5	6·36	·13	2·54	14·1	48·9	47·37	18·6

* *Proc. Inst. C.E.*, vol. xxx.

Example 19.—Apply Rankine's formula to determine the breaking weight of a wrought-iron hollow cylindrical column, its length being 10 feet, external diameter $1\frac{1}{2}$ inches, and thickness of metal $\frac{1}{10}$ th inch; the ends being bedded flat.

In Rankine's formula, equation (15), we have

$$f = 16 \text{ tons}, \quad c = 36,000, \quad S = .44,$$

$$l = 120 \text{ inches}, \quad r^2 = \frac{(1.5)^2 + (1.3)^2}{16} = 0.246, \quad \frac{l^2}{r^2} = 58,536.$$

Substituting, we get

$$P = \frac{16 \times .44}{1 + \frac{58,536}{36,000}} = 2.7 \text{ tons},$$

which nearly agrees with the result found by experiment as shown in the Table.

185. **Wrought-iron Struts of Angle, Tee, Channel, and Miscellaneous Sections.**—Gordon's formulæ, equations (13) and (14), may be applied to calculate the strengths of wrought-iron struts and columns of angle, tee, channel, and cruciform section, by giving certain values to the constants f and a .

Mr. Unwin recommends the following:—

$$f = 19 \text{ tons}, \quad a = \frac{1}{900}.$$

The diameter to be used for such sections is found by taking the shortest diameter of a rectangle or triangle circumscribing the section.

Example 20.—Apply Gordon's formula to determine the breaking weight of a wrought-iron strut of angular section $3 \times 3 \times \frac{3}{8}$, its length being 18 inches and ends fixed.

The least diameter of the section $d = 2.12$ inches.

Applying formula (13) we get, putting $r = \frac{18}{2.12} = 8.5$,

$$P = \frac{19 \times 2.11}{1 + \frac{(8.5)^2}{900}} = 37.1 \text{ tons}.$$

Example 21.—If the angle bar in the last example be used as a strut in a lattice girder with pin connections at its ends; what is the safe stress to apply to it, the factor of safety being 4?

In this case we must use equation (14), from which we get the breaking weight

$$P = \frac{19 \times 2.11}{1 + 4 \frac{(8.5)^2}{900}} = 30.4 \text{ tons.}$$

$$\text{Safe load} = \frac{30.4}{4} = 7.6 \text{ tons.}$$

Example 22.—The diagonal brace of a Warren girder is 10 feet long and is composed of two tee bars $6 \times 3 \times \frac{1}{2}$ placed back to back and rivetted together. What is the maximum compressive working stress that should be applied to it when the ends are firmly rivetted to the booms?

$$\text{Area of } 6 \times 3 \times \frac{1}{2} \text{ T} = 4.25 \text{ square inches,}$$

$$S = 2 \times 4.25 = 8.5 \text{ square inches,}$$

$$\text{least diameter } d = 6 \text{ inches, } l = 120 \text{ inches.}$$

By Gordon's formula we get breaking stress

$$P = \frac{19 \times 8.5}{1 + \frac{(20)^2}{900}} = 111.8 \text{ tons.}$$

Adopting a factor of safety of 4 we get the working stress

$$= \frac{111.8}{4} = 27.9 \text{ tons.}$$

If each end of the strut be connected to the boom by a single pin we must use equation (14).

$$P = \frac{19 \times 8.5}{1 + 4 \frac{(20)^2}{900}} = 58.1 \text{ tons,}$$

or safe load = 14.5 tons, about one-half of that in the first case.

Example 23.—What must be the thickness of the bars in a strut similar in section to that in the last example, if the length be 12 feet and the maximum working stress 12.5 tons; the ends being connected by pins?

By transposing equation (14) we get—

$$S = \frac{P}{f} \left\{ 1 + 4 a \left(\frac{l}{d} \right)^2 \right\}.$$

In this equation we have the following values:—

$$P = 12.5 \times 4 = 50 \text{ tons,} \quad a = \frac{1}{900}, \quad f = 19 \text{ tons,}$$

$$l = 144 \text{ inches,} \quad d = 6 \text{ inches.}$$

By substitution

$$S = \frac{50}{19} \left\{ 1 + \frac{4}{900} (24)^2 \right\} = 9.36 \text{ square inches.}$$

Each tee bar must, therefore, have a section = 4.68 square inches, or the required thickness = 0.55 inch.

166. **Mr. Christie's Experiments.**—Mr. Christie has recently made, in America, a number of experiments on wrought-iron struts of angle, tee, and channel sections with the ends fixed in four different ways.

- 1st. With loose flat ends,
- 2nd. With fixed ends,
- 3rd. With hinged ends,
- 4th. With rounded ends.

He found that in all cases, except for very short lengths, the bars bent in the direction of the least radius of gyration.

Table XXXI. gives the results of his investigations.

* TABLE XXXI.—AVERAGE RESULTS OF MR. CHRISTIE'S TESTS OF WROUGHT-IRON STRUTS OF ANGLE AND TEE SECTIONS.

Rates of Length to Least Radius of Gyration $\frac{l}{r}$	BREAKING WEIGHT IN POUNDS PER SQUARE INCH.			
	Flat Ends.	Fixed Ends.	Hinged Ends.	Round Ends.
20	46,000	46,000	46,000	44,000
40	40,000	40,000	40,000	36,500
80	32,000	32,000	31,500	25,000
100	29,800	30,000	28,000	20,500
200	14,500	17,500	10,800	6,000
300	7,200	9,000	5,000	2,800
400	3,000	5,200	2,500	1,500
480	1,900	...	1,800	...

* *Proc. Inst. C.E.*, vol. lxxvii., p. 396.

III. STEEL COLUMNS.

167. Steel Columns of Solid Round and Rectangular Sections.—The laws which govern the strength of steel columns are very similar to those which apply to those made of wrought iron.

A good deal of the knowledge which we possess on the strength of steel columns of solid section is due to the investigations of Mr. B. Baker, who recommends the following values for the constants in Gordon's formulæ :—

$$\begin{array}{l} \text{Solid round pillars,} \\ \text{Solid rectangular} \\ \text{pillars,} \end{array} \left\{ \begin{array}{l} \text{Mild steel } f = 30 \text{ tons, } a = \frac{1}{1,400}; \\ \text{Strong steel } f = 51 \text{ tons, } a = \frac{1}{900}. \\ \text{Mild steel } f = 30 \text{ tons, } a = \frac{1}{2,480}; \\ \text{Strong steel } f = 51 \text{ tons, } a = \frac{1}{1,600}. \end{array} \right.$$

168. Steel Columns of L and I-Section.—Mr. Christie gives the following table of the average strengths of steel struts of angle and tee section, for different ratios of length to radius of gyration :—

TABLE XXXII. — AVERAGE RESULTS OF MR. CHRISTIE'S TESTS OF STEEL STRUTS OF ANGLE AND TEE SECTION; THE ENDS BEING FLAT.

Ratio $\frac{l}{r}$	BREAKING WEIGHT IN POUNDS PER SQUARE INCH.		Ratio $\frac{l}{r}$	BREAKING WEIGHT IN POUNDS PER SQUARE INCH.	
	Mild Steel.	Hard Steel.		Mild Steel.	Hard Steel.
20	72,000	100,000	180	19,500	23,800
40	46,000	65,000	200	16,500	20,000
60	41,000	58,000	220	14,000	16,900
80	38,000	54,000	240	12,000	14,000
100	35,000	47,000	260	10,300	11,800
120	31,500	40,000	280	9,000	10,200
140	27,000	33,500	300	7,900	9,000
160	23,000	28,300			

Mr. Fidler (*Bridge Construction*, p. 180) says:—"For the most ordinary ratios of length to radius of gyration, i.e., for all ratios greater than 20 and less than 200, the results of Mr. Christie's experiments, as given in his own tables, would be expressed with a fair degree of accuracy by the following empirical formulæ:—

$$\text{Mild steel } p = \frac{48,000}{1 + \frac{l^2}{30,000 r^2}}$$

$$\text{Hard steel } p = \frac{70,000}{1 + \frac{l^2}{20,000 r^2}}$$

in which r = radius of gyration."

Example 24.—What is the breaking weight of a solid rectangular pillar of mild cast steel, its length being 12 feet and section 3 inches by 2 inches; both ends being securely fixed?

$$f = 30 \text{ tons}, \quad a = \frac{1}{2,480}, \quad S = 3 \times 2 = 6 \text{ square inches,}$$

$$l = 144 \text{ inches,} \quad \text{least diameter } d = 2 \text{ inches.}$$

From equation (13), we get breaking weight—

$$P = \frac{30 \times 6}{1 + \frac{(72)^2}{2,480}} = 58.2 \text{ tons.}$$

If the pillar be jointed at the ends, we get from equation (14)—

$$P = \frac{30 \times 6}{1 + 4 \frac{(72)^2}{2,480}} = 19.2 \text{ tons.}$$

Example 25.—What is the safe working stress on a round strut, 3 inches diameter and 8 feet long, made of mild forged steel; both ends being jointed?

$$f = 30 \text{ tons}, \quad a = \frac{1}{1,400}, \quad S = .7854 (3)^2 = 7.0686 \text{ sq. inches,}$$

$$l = 96 \text{ inches,} \quad d = 3 \text{ inches,} \quad \frac{l}{d} = \frac{96}{3} = 32.$$

From equation (14), we get the breaking weight—

$$P = \frac{30 \times 7.0686}{1 + 4 \times \frac{(32)^2}{1,400}} = 54 \text{ tons.}$$

If the load be a steady one, the safe working stress will be (adopting a factor of safety of 4) $\frac{54}{4} = 13.5$ tons.

If it be attended with vibration, the working stress will be $\frac{54}{5} = 10.8$ tons.

CHAPTER XII.

BRACED GIRDERS.

BOLLMAN TRUSS, TRAPEZOIDAL TRUSS, FINK TRUSS.

169. Braced Girders differ from ordinary plate girders, mainly in the construction of their webs. In the latter the web is a continuous plate connecting the flanges together, while in the former it consists of a number of bars usually termed braces or lattices. These braces divide the girder into a number of triangles or trapeziums, and they transmit the horizontal stresses from one flange to the other. The braces are exposed to direct stresses in the direction of their lengths, either of compression or tension; in the former case they are termed *struts*, and in the latter *ties*.

170. Different kinds of Braced Girders.—Braced girders are divided into a number of different types, many of which are known by the names of their inventors. Thus we have *the Bollman Truss, the Trapezoidal Truss, the Fink Truss, the Warren Girder, the Lattice Girder, the Bowstring Girder, &c.*

I. BOLLMAN TRUSS.

171. Simple Triangular Truss with Single Load — Bollman Truss. — The simplest form of braced girder is the triangular truss shown in fig. 87, and is sometimes known as the Bollman

truss. It consists of a horizontal member, A B, and two inclined members, A C and B C, with a vertical connecting member, D C. When this truss rests on two supports or abutments at its extremities A and B, and is loaded with a weight, P, resting at the point, D, the stress on A B will be a constant direct compressive one throughout its length; so also will be the stress on the vertical member D C, while the stresses on A C and C B will be tensile.

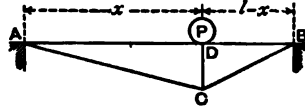

Fig. 87.

Let l = span or distance between the supports,
 x = distance of D from the left support,
 d = D C the depth of the truss.

The supporting forces at A and B will, therefore, be

$$P \frac{l-x}{l} \text{ and } P \frac{x}{l}$$

respectively, and the bending moment at D will be

$$M_D = P \frac{x(l-x)}{l},$$

and the horizontal stress on A B will be

$$S_{AB} = P \frac{x(l-x)}{ld} \quad (1).$$

This expression is also equal to the horizontal component of the stresses on A C and B C; we have, therefore,

$$S_{AC} = S_{AB} \times \frac{AC}{AD} = P \frac{x(l-x)}{ld} \cdot \frac{\sqrt{x^2+d^2}}{x} \quad (2).$$

$$S_{BC} = S_{AB} \times \frac{BC}{BD} = P \frac{x(l-x)}{ld} \cdot \frac{\sqrt{(l-x)^2+d^2}}{l-x} \quad (3).$$

The stress on D C is evidently equal to the vertical force P,
 or $S_{DC} = P$.

If the point D be midway between A and B, we get—

$$x = \frac{l}{2}, \quad S_{AB} = \frac{Pl}{4d}$$

$$S_{AC} = S_{BC} = \frac{P}{4d} \sqrt{l^2 + 4d^2}.$$

The above is the analytical method of determining the stresses in a truss of this kind.

In nearly all braced girders the stresses may be got more readily by a stress-diagram, which for the case under consideration is constructed as follows:—

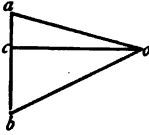

Fig. 88.

Take a vertical line, ab (fig. 88), equal to the weight P on any scale of forces; draw ao parallel to AC and bo parallel to BC ; these lines meet at o . Through o draw oc parallel to AB . Fig. 88 will be a complete stress diagram of the truss.

$$\begin{aligned} bo &= S_{BC} & ao &= S_{AC} & oc &= S_{AB} & ab &= S_{DC} \\ ac &= \text{upward reaction at A,} \\ bc &= \text{upward reaction at B.} \end{aligned}$$

By measuring these lines on the adopted scale we find at once all the stresses required.

Example 1.—A trussed girder, similar to that shown in fig. 87, is divided into two panels, AD and BD , of 16 feet and 8 feet respectively, and the depth $DC = 4$ feet. Find the supporting forces and the stresses on the different members when a load of 3 tons rests at the point D .

(a.) *Analytical Solution.*—

$$\text{Reaction of abutment at A} = \frac{3 \times 8}{24} = 1 \text{ ton.}$$

$$\text{,, ,, B} = \frac{3 \times 16}{24} = 2 \text{ tons.}$$

$$\text{From equation (1) } + S_{AB} = 3 \cdot \frac{16 \times 8}{24 \times 4} = 4 \text{ tons.}$$

$$\text{,, (2) } - S_{AC} = 4 \cdot \frac{\sqrt{(16)^2 + (4)^2}}{16} = 4.12 \text{ tons.}$$

$$\text{,, (3) } - S_{BC} = 4 \cdot \frac{\sqrt{(8)^2 + (4)^2}}{8} = 4.47 \text{ tons.}$$

$$+ S_{DC} = 3 \text{ tons.}$$

(b.) *Graphic Solution.*—In fig. 88 draw the vertical line $ab = 3$ tons by scale. Through its extremities a and b draw ao , bo parallel to AC and BC respectively. Through their point of intersection, o , draw oc parallel to AB .

We find by scaling—

$$\begin{aligned} a b &= S_{DC} = + 3 \text{ tons,} \\ o c &= S_{AB} = + 4 \text{ tons,} \\ o a &= S_{AC} = - 4.12 \text{ tons,} \\ o b &= S_{BC} = - 4.47 \text{ tons,} \end{aligned}$$

which agree with the results as found by analysis.

172. **Bollman Truss with Distributed Load.**—If the load P , coming on the truss, instead of being concentrated over the vertical strut, be evenly distributed along the top member, $A B$, the stresses on the various members of the truss will be different to those previously found. In such case

$$\text{the reactions at the abutments will each} = \frac{P}{2}.$$

$$\text{the thrust on the vertical member will} = \frac{P}{2},$$

and the direct stresses on the other members will be exactly one-half of those produced when the load is a concentrated one. It must be noticed, however, that the stress on the top member, $A B$, is not a purely direct compressive one; as, in addition to the direct thrust, there are bending stresses produced. In fact, $A B$ partakes somewhat of the nature of a beam continuous over two spans, the central support being $D C$.

Trusses of this simple pattern do not conveniently lend themselves for carrying distributed loads, but are more suited for supporting a single load resting directly over the vertical strut.

If the truss shown in fig. 87 be inverted as shown in fig. 89, the load should be applied at D , the foot of the vertical member. If applied at the top, the load, or part of it, would travel down $C D$ and produce a bending stress on the horizontal member, which is not desirable. If, instead of doing this, the load be transmitted *entirely* through the inclined members $A C$ and $B C$, then there would be no need of the vertical member. With the load resting at D , the method of calculating the stresses is the same as that given for truss, fig. 87, but the character of the stresses will be different. Those in $A B$ and $C D$ being tensile, while those in $A C$ and $C B$ will be compressive, just the reverse of the former case.

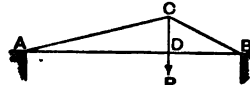

Fig. 89.

173. **Bollman Truss of Three Divisions.**—Fig. 90 is a development of the truss we have been considering; the horizontal member is divided into three equal parts, and two separate and distinct triangular trusses, $A C B$, $A D B$, are formed, the member $A B$ being common to both. If the truss support a uniformly distributed load, P , on

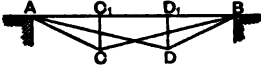

Fig. 90.

each of the three panels into which it is divided, it will be equivalent to two concentrated loads, each equal to P , resting on the points C_1 and D_1 , and the supporting force at each abutment, neglecting that which comes directly on it will be equal to P .

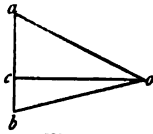

Fig. 91.

If each triangular truss, $A C B$, $A D B$, be considered separately and independently, the stresses on the different members may be found exactly in the manner described for fig. 87.

The total stress on $A B$ will be equal to the sum of the two stresses on this member as found from each separate load.

174. **Bollman Truss of any Number of Panels.**—It is not a difficult investigation to find a general formula for determining the total stress on the horizontal member of a Bollman truss of any number of equal panels when loaded uniformly.

Let n = number of equal panels in truss,
 P = weight on each panel,
 d = depth of the truss,
 l = span of truss,
 p = intensity of distributed load.

We have seen from equation (1) that the horizontal stress on the top member arising from one weight, P , at a distance, x , from the abutment is $= P \cdot x \frac{l-x}{ld}$.

$$\text{Putting } x = \frac{l}{n}, \text{ and } P = \frac{pl}{n},$$

by substitution we get—

$$\text{The horizontal stress on } A B \text{ from one weight} = p l^2 \frac{n-1}{n^3 d}.$$

As there are $(n-1)$ weights, we get—

$$\text{Total stress on horiz. member} = \Sigma p l^2 \cdot \frac{n-1}{n^3 d} = \frac{p l^2}{d} \cdot \frac{n^2-1}{6 n^2}. \quad (4).$$

For truss with two panels $n=2$,	$S_{AB} = \frac{1}{8} \frac{p l^2}{d}$.
" " three " $n=3$,	$S_{AB} = \frac{4}{27} \frac{p l^2}{d}$.
" " four " $n=4$,	$S_{AB} = \frac{5}{32} \frac{p l^2}{d}$.
" " five " $n=5$,	$S_{AB} = \frac{4}{25} \frac{p l^2}{d}$.
" " six " $n=6$,	$S_{AB} = \frac{35}{216} \frac{p l^2}{d}$.
" " seven " $n=7$,	$S_{AB} = \frac{8}{49} \frac{p l^2}{d}$.
" " eight " $n=8$,	$S_{AB} = \frac{21}{128} \frac{p l^2}{d}$.
" " infinite " $n=\alpha$,	$S_{AB} = \frac{1}{6} \frac{p l^2}{d}$.

It will be seen, therefore, that no matter what the number of panels, the horizontal stress on the top member varies between $\frac{1}{8} \frac{p l^2}{d}$ and $\frac{1}{6} \frac{p l^2}{d}$ when it is loaded with a uniformly distributed load of p per unit of length.

Example 2.—A Bollman truss of three panels is 24 feet span and 4 feet deep, and is loaded uniformly with $\frac{7}{8}$ ton per foot. What is the stress on each member?

Total distributed load on truss = $24 \times \frac{7}{8} = 21$ tons.

This is equivalent to 7 tons on each panel, or to two loads of 7 tons each resting on the points C_1 and D_1 , fig. 90. The compressive stresses on $C C_1$ and $D D_1$ are, therefore, each equal to 7 tons.

Graphic Solution.—Consider the triangular truss $A O B$ by itself; this supports a load of 7 tons, acting at C_1 . Draw the vertical line, $a b$ (fig. 91) = 7 tons. Through its extremities draw $a o$, $b o$, parallel to $A C$ and $B C$ respectively. Through o draw $o c$ parallel to $A B$. We have, therefore, by scaling—

$$\begin{aligned} S_{AC} &= a o = -10.4 \text{ tons,} \\ S_{BC} &= b o = -9.6 \text{ tons,} \\ S_{AB} &= c o = +9.3 \text{ tons.} \end{aligned}$$

By considering the triangle $A D B$ we get similar results, namely:—

$$S_{AD} = -9.6 \text{ tons,} \quad S_{BD} = -10.4 \text{ tons,} \quad S_{AB} = +9.3 \text{ tons.}$$

The total stress on A B will, therefore, be $9.3 + 9.3 = 18.6$ tons.

The result may be checked algebraically from equation (4) by putting—

$$n = 3, \quad p = \frac{7}{8}, \quad l = 24, \quad d = 4.$$

We then get from equation (4)—

$$S_{A,B} = \frac{7}{8} \times \frac{(24)^2}{4} \times \frac{(3)^2 - 1}{6 \times (3)^2} = 18.66 \text{ tons.}$$

Example 3.—A railway bridge, 60 feet span, carrying a single line of railway, is supported by two Bollman trusses 10 feet deep; each being divided into six equal panels. If the dead weight of the structure be 120 tons, and the rolling load of a train of carriages be equal to $1\frac{1}{2}$ tons per foot, determine the stresses on the various members of the truss.

We have—Dead load	= 120 tons.
Live load = $60 \times 1\frac{1}{2}$	= 90 „
Total load on bridge	= 210 „
„ each truss	= 105 „

This is equivalent to 17.5 tons resting on each panel, and as the load is transmitted to the main trusses by five cross girders, the actual load on each truss = $17.5 \times 5 = 87.5$, the difference between this and 105 tons being 17.5 tons, which is carried directly by the abutments, and does not affect the stresses on the truss.

Fig. 92 represents a skeleton sketch of one of the trusses drawn to scale. Loads of 17.5 tons rest on each of the points $C_1, D_1, E_1, F_1,$ and G_1 , and it is evident that the stress on each of the five vertical members $CC_1, DD_1, EE_1, FF_1, GG_1$ is +17.5 tons. The readiest method of finding the stresses on the other members is by the aid of the resolution of forces. Consider the triangular truss A B C; this is a complete truss in itself, and is loaded with a weight of 17.5 tons acting at C_1 .

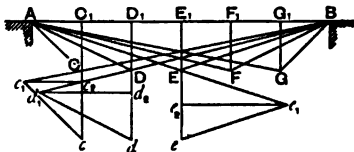

Fig. 92.

This weight passes unaltered down $C_1 C$, producing in this member a thrust of 17.5 tons. At the point C there are, therefore, three forces acting—viz., the compressive stress on $C_1 C$ and the tensile stresses on A C and B C. As one of these stresses—namely,

that on C, C—is known, the other two may be found by the

resolution of forces, as explained in Art. 60. Draw, therefore, to any scale the vertical line $Cc = 17.5$ tons. Through c draw c_1 parallel to AC , and meeting BC produced at c_1 . We have, then, by scaling—

$$\begin{aligned} c c_1 &= \text{tensile stress on } AC = -20.62 \text{ tons.} \\ C c_1 &= \text{tensile stress on } BC = -14.87 \text{ tons.} \end{aligned}$$

In the same manner we may consider the other triangular trusses. Each is loaded with a weight of 17.5 tons, and by proceeding exactly on the same lines as just explained we have the following results :—

For truss ADB —

$$\begin{aligned} d d_1 &= \text{tensile stress on } AD = -26.06 \text{ tons,} \\ D d_1 &= \text{,, ,, } DB = -24.03 \text{ ,,} \\ D d &= \text{compressive ,, } D_1 D = +17.5 \text{ ,,} \end{aligned}$$

For truss AEB —

$$\begin{aligned} E e &= \text{compressive stress on } E_1 E = +17.5 \text{ tons,} \\ E e_1 &= \text{tensile ,, } AE = -27.67 \text{ ,,} \\ e e_1 &= \text{,, ,, } BE = -27.67 \text{ ,,} \end{aligned}$$

The stresses on the members of the triangular trusses AFB and AGB will be exactly the same as those on ADB and ACB .

The horizontal line, $c_1 c_2$, represents the horizontal stress on the member AB arising from the load at C_1 . Also—

$$\begin{aligned} d_1 d_2 &= \text{compressive stress on } AB \text{ arising from the load at } D_1. \\ e_1 e_2 &= \text{,, ,, ,, } E_1. \end{aligned}$$

And as the stresses on AB from the loads at F_1 and G_1 are respectively equal to those from the loads on D_1 and C_1 we have the following result :—

Total compressive stress on AB —

$$= 2(c_1 c_2 + d_1 d_2) + e_1 e_2 = 2(14.57 + 23.305) + 26.25 = 102 \text{ tons.}$$

This result may be checked from equation (4)—

$$p = 1\frac{1}{2} \text{ tons per foot, } l = 60 \text{ feet, } d = 10 \text{ feet, } n = 6.$$

Substituting we get—

$$\text{Stress on } AB = \frac{1.75 (60)^2}{10} \times \frac{35}{216} = 102.1 \text{ tons,}$$

which agrees with the result previously found.

175. **Defects of the Bollman Truss.**—The Bollman truss has one serious drawback which becomes very noticeable in large spans.

It will be seen that the two ties supporting any one of the vertical struts except the central one are of unequal length; consequently any expansion which may take place, whether it arise from the strain on the bars, or an increase of temperature, affects their lengths unequally; the long bar naturally extending more than the short one. This tends to throw the vertical struts out of the perpendicular and to introduce secondary stresses into the structure.

This defect does not exist in other trusses, such as the Fink truss for example, which latter is superior to the Bollman.

II. TRAPEZOIDAL TRUSS.

176. **Trapezoidal Truss.**—Another simple form of truss is that in which the constituent trusses are trapezoids instead of triangles, examples of which are shown in figs. 93 and 94.

In fig. 93 the longer horizontal member is uppermost, and is divided into an odd number (five) of equal panels, and the truss consists of the two trapezoidal trusses $A C D B$ and $A E F B$.

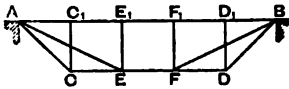

Fig. 93.

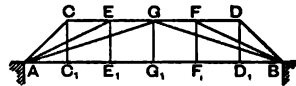

Fig. 94.

In fig. 94 the shorter horizontal member is uppermost, and the truss is divided into an even number (six) of equal panels, and consists of the two trapezoidal trusses $A C D B$ and $A E F B$, and the triangular truss $A G B$.

In all trusses of this kind with an even number of bays there will be one triangular truss.

In fig. 93 the load is placed on the top of the truss, and the top member $A B$ and also the vertical members will be in compression; while the bottom member $O D$, as well as the inclined members, will be subject to tensile stresses. In the truss represented in fig. 94 the load will be applied at the bottom, and, as before, the top and bottom members will be exposed to compressive and tensile stresses respectively. The vertical members will be in tension, and the inclined members will all be in compression.

The form of truss shown in fig. 93, or that with the longer horizontal member uppermost, is much superior to the other, on account of the diagonal members being in tension. When these members are in compression they require a good deal of extra metal, on account of their length, to prevent their buckling.

177. Trapezoidal Truss of any number of Panels.—

Let n = number of equal panels in truss,
 d = depth of truss,
 l = span of truss,
 p = intensity of distributed load (say in tons per foot),
 P = total load on each panel.

$$P = \frac{pl}{n}.$$

(a.) If the number of bays be even, there will be a central triangle, and

$$S_{AB} = \frac{pl^2}{8d} \dots \dots \dots (5).$$

(b.) If the number of bays be odd

$$S_{AB} = \frac{pl^2}{d} \cdot \frac{n^2 - 1}{8n^2} \dots \dots \dots (6).$$

If we compare this formula (equation 6) with equation (4), we see that the horizontal stress in a Bollman truss is greater than that in a trapezoidal truss of the same span and depth and loaded with the same weight, in the proportion of 4 to 3.

Example 4.—A simple trapezoidal truss, similar to that shown in fig. 95, is 24 feet span and 6 feet deep; the length of the upper chord is 9 feet. Find the stress on each member when loaded with 4 tons at each joint.

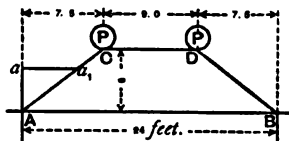

Fig. 95.

The upward reaction at each abutment = 4 tons. Draw, therefore, the vertical line $Aa = 4$ tons. Through a draw a_1 parallel to AB .

$a a_1$ = tensile stress on $AB = - 5$ tons, by scale,
 $A a_1$ = compressive stress on $AC = + 6.4$ tons, by scale.
 Stress on $CD =$ stress on $AB = + 5$ tons.

As the loads rest on C and D there should be no vertical struts at these points; if the load be carried on the bottom

member A B it would be necessary to introduce these vertical members which, in this latter case, would be subject to tensile stresses, equal to the weights suspended at their feet.

The solution may also be effected by the principle of moments. Taking moments about the point C, we get—

$$S_{AB} \times 6 = 4 \times 7.5, \text{ or } S_{AB} = 5 \text{ tons} = S_{CD},$$

$$S_{AC} = S_{AB} \times \frac{AC}{7.5} = 5 \times \frac{9.6}{7.5} = 6.4 \text{ tons.}$$

Example 5.—A bridge 54 feet span and 8 feet in width is supported by two timber trusses of the design shown in fig. 96. Each truss is 6 feet deep and divided by two vertical posts into three equal parts. Find the stresses on the various members, the total weight on the bridge

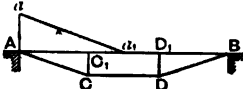

Fig. 96.

being equivalent to 200 lbs. per square foot of platform.

$$\text{Total weight on bridge} = 54 \times 8 \times 200 \text{ lbs.} = 86,400 \text{ lbs.}$$

$$\text{,, one truss} = 43,200 \text{ lbs.}$$

$$\left. \begin{array}{l} \text{Load resting on each of} \\ \text{the points } C_1 \text{ and } D_1 \end{array} \right\} = \frac{43,200}{3} = 14,400 \text{ lbs.}$$

$$\left. \begin{array}{l} \text{Upward reaction at} \\ \text{each abutment} \end{array} \right\} = 14,400 \text{ lbs.}$$

At the point A, there are three forces acting, viz.:—The upward reaction which = 14,400 lbs. and the stresses on A B and A C. Draw, therefore, the vertical line A a = 14,400 lbs. Through a draw a a_1 parallel to A C, meeting A B at a_1 .

$$S_{AC} = a a_1 = - 45,600 \text{ lbs. by scale,}$$

$$S_{AB} = A a_1 = + 43,200 \text{ lbs. ,,}$$

The stress on A B is constant throughout its length, and the stress on O D is equal to it in amount, but tensile. Stress on $C_1 C$ = stress on $D_1 D$ = + 14,400 lbs.

The stress on the horizontal members may also be found analytically from equation (6).

By putting $n = 3$, $d = 6$ feet, $l = 54$ feet, $p = 800$ lbs., we get—

$$S_{AB} = \frac{800 (54)^2}{6} \times \frac{(3)^2 - 1}{8 (3)^2} = 43,200 \text{ lbs.}$$

III. FINK TRUSS.

178. **Fink Truss.**—The Fink truss, called after its inventor, is, like the Bollman truss, much used in America for timber bridges.

Fig 97 represents one of these trusses, consisting of what are called primary and secondary systems. The primary truss is the triangle $A B C$, the strut $C D$ supporting the horizontal member $A B$ at its centre. The triangles $A D E$ and $D B F$ are the secondary systems. The vertical struts $G E$ and $F H$ further support the horizontal member $A B$ at the points G and H , which are midway between A and D , and D and B respectively. If the top member of the truss require extra support, it may be accomplished by further subdividing the truss into tertiary systems, and this is done by introducing additional struts midway between the points A , G , D , H , and B , and trussing them in a similar manner to that adopted for the primary and secondary systems.

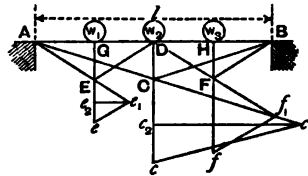

Fig. 97.

The top member or boom, $A B$, is common to all the systems, and the direct stress upon it, which is compressive, will be uniform throughout its whole length, when the load on the truss is an evenly distributed one. This stress will be equal to the sum of the horizontal stresses due to each of the systems.

Suppose the truss to be loaded at the points G , D , and H , with weights W_1 , W_2 , and W_3 respectively.

$$\text{Let } l = \text{span of truss, } d = \text{depth.}$$

First consider the triangular truss, $A E D$, as an independent truss supported at A and D ; this has a weight, W_1 , resting at G . Taking moments about E , we get—

$$S_{AD} \times d = \frac{W_1}{2} \times A G,$$

$$\text{or } S_{AD} = \frac{W_1 l}{8 d} \text{ (compressive).}$$

$$S_{AE} = S_{ED} = S_{AD} \times \sec \angle G A E = \frac{W_1 l}{8 d} \times \frac{A E}{A G} \text{ (tensile).}$$

$$S_{GE} = W_1 \text{ (compressive).}$$

Similarly, we get for triangle D F B—

$$S_{BD} = \frac{W_2 l}{8d}. \quad S_{DF} = S_{BF} = \frac{W_3 l}{8d} \times \frac{FB}{HB} \\ S_{HF} = W_3.$$

Next consider the triangle A C B.

Here the thrust acting along D C is not simply the weight W_2 resting at D, but in addition the vertical components of the stresses on the members E D and D F. These latter are $\frac{W_1}{2}$ and $\frac{W_3}{2}$ respectively; so that the total thrust on D C is

$$S_{DC} = W_2 + \frac{1}{2}(W_1 + W_3).$$

The stresses produced on the different members of A C B, arising from this thrust on D C, are—

$$S_{AB} = \left(W_2 + \frac{W_1 + W_3}{2} \right) \frac{l}{4d} \\ S_{AC} = S_{BC} = \left(W_2 + \frac{W_1 + W_3}{2} \right) \frac{l}{4d} \times \frac{AC}{AD}.$$

Taking all the loads into consideration simultaneously, the total stresses on A D and D B are—

$$S_{AD} = \frac{W_1 l}{8d} + \left(W_2 + \frac{W_1 + W_3}{2} \right) \frac{l}{4d} = \frac{l}{4d} \left(W_1 + W_2 + \frac{W_3}{2} \right). \\ S_{DB} = \frac{W_3 l}{8d} + \left(W_2 + \frac{W_1 + W_3}{2} \right) \frac{l}{4d} = \frac{l}{4d} \left(W_2 + W_3 + \frac{W_1}{2} \right).$$

The stresses on the other members are not altered, but remain at the values already given.

If the weight on each panel = W , we get $W_1 = W_2 = W_3 = W$, and substituting in the above expressions we get the following values for the stresses :—

$$S_{GE} = S_{HF} = W. \\ S_{DC} = 2W. \\ S_{AD} = S_{DB} = \frac{Wl}{2d} \left(1 + \frac{1}{4} \right) = \frac{5Wl}{8d}. \\ S_{AE} = S_{ED} = S_{DF} = S_{BF} = \frac{Wl}{8d} \times \frac{AE}{AG}. \\ S_{AC} = S_{BC} = \frac{Wl}{2d} \times \frac{AC}{AD}.$$

If the truss be loaded with a uniformly distributed weight, equal to p per unit of length, we get $W = \frac{pl}{4}$.

Substituting this value for W in the previous equations, we get—

$$S_{GH} = S_{HF} = \frac{pl}{4}. \quad S_{DO} = \frac{pl}{2}.$$

$$S_{AD} = \frac{pl^2}{8d} \times \frac{5}{4} = \frac{5}{32} \frac{pl^2}{d},$$

and so on.

If the truss, instead of being divided into 4 equal bays, be divided into a number represented by any other power of 2, it will be an easy matter to find the stresses in the manner indicated.

The sketch shown in fig. 98 represents a more extended form of the Fink truss. The seven uprights at 1, 2, 3, &c., divide the span into eight equal panels. If a weight, W , rest on each of the points 1, 2, 3, &c., the truss may be considered to be made up of seven distinct and independent trusses. Each of the vertical struts at 1, 3, 5, and 7 is exposed to a compressive stress equal to W . Each of the struts at 2 and 6 to a compressive stress equal to $2W$; while the central strut at 4 has a compressive stress equal to $4W$.

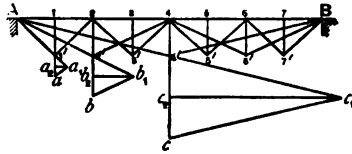

Fig. 98.

179. Fink Truss of any Number of Equal Panels loaded uniformly.

- Let n = number of panels in the truss,
- l = span of truss in feet,
- d = depth of truss in feet,
- w = weight per foot resting on truss,
- W = total weight, or $W = wl$.

The number of panels must always be equal to some power of 2, as 2, 4, 8, 16, &c.; the most general form is that where $n = 8$.
 (a.) When $n = 2$, we get simply an inverted triangular truss.

The stress on the vertical post = $\frac{W}{2}$.

The horizontal stress on the boom = $\frac{W l}{8 d}$. (7).

The stresses on the inclined ties are each = $\frac{W l}{8 d}$ sec. θ ,

where θ = angle of inclination of the ties to the boom.

$$\text{Sec } \theta = \frac{\sqrt{\frac{l^2}{4} + d^2}}{l} = \frac{\sqrt{l^2 + 4 d^2}}{l};$$

so that

$$\text{Stress on tie} = \frac{W}{8 d} \sqrt{l^2 + 4 d^2} \quad . \quad . \quad (8).$$

(b.) $n = 4$. In a truss of four equal panels the stress on the central post is the same as in the latter case, and consequently the stresses on the long inclined stays are also the same, that is, of course, when the span and depth are the same; the introduction of the secondary trusses do not alter these in any way. It will, therefore, only be necessary to consider the stresses in the two secondary triangles. The stresses on the two secondary vertical posts are each equal to $\frac{W}{4}$, and the stress on the horizontal boom arising from these thrusts = $\frac{1}{4} \frac{W l}{8 d} = \frac{W l}{32 d}$. The total stress on the boom from the total load will be equal to the sum of the stresses due to the primary and secondary trusses, or

$$\text{Total stress on boom} = \frac{W l}{8 d} + \frac{W l}{32 d} = \frac{5 W l}{32 d} \quad (9).$$

The stresses on the inclined ties of the secondary trusses are each equal to $\frac{W l}{32 d} \times \text{sec. } \theta_1$, where

θ_1 = angle of inclination of these ties to the boom,

$$\text{sec. } \theta_1 = \frac{\sqrt{\left(\frac{l}{4}\right)^2 + d^2}}{\frac{l}{4}} = \frac{\sqrt{l^2 + 16 d^2}}{l};$$

∴ stress on secondary ties

$$= \frac{W l}{32 d} \times \frac{\sqrt{l^2 + 16 d^2}}{l} = W \frac{\sqrt{l^2 + 16 d^2}}{32 d} \quad (10).$$

(c) $n = 8$. In this case there are three systems of trusses—viz., primary, secondary, and tertiary.

The stresses on the central vertical post 44' (fig. 98) and the primary ties A 4' and B 4' remain the same as in the previous cases.

The stresses on the secondary struts and ties also remain the same as in the last case.

The stresses on the tertiary posts at 1, 3, 5, and 7 are each equal to $\frac{W}{8}$.

The horizontal stresses on the different segments of the boom, A 2, 2 4, 4 6, and 6 B arising from these thrusts on the posts, are each equal to $\frac{W}{8} \times \frac{l}{16 d} = \frac{W l}{128 d}$

The total stress on the boom

$$= \frac{W l}{8 d} + \frac{W l}{32 d} + \frac{W l}{128 d} = \frac{W l}{d} \left(\frac{1}{8} + \frac{1}{32} + \frac{1}{128} \right) = \frac{21 W l}{128 d} \quad (11).$$

The tensile stresses on the inclined ties of the tertiary trusses are each equal to $\frac{W l}{128 d} \sec \theta_2$

where $\theta_2 =$ angle of inclination of these ties to the boom.

$$\sec \theta_2 = \frac{A 1'}{A 1} = \frac{\sqrt{\left(\frac{l}{8}\right)^2 + d^2}}{\frac{l}{8}} = \frac{\sqrt{l^2 + 64 d^2}}{l};$$

$$\therefore \text{stress on tertiary ties} = \frac{W}{128 d} \sqrt{l^2 + 64 d^2} \quad (12).$$

Example 6.—A Fink truss of four equal divisions is 25 feet span and 3 feet 9 inches deep, and carries a uniformly distributed load of $1\frac{1}{2}$ tons per foot. Find the stresses on the different members.

Total load on truss = $25 \times 1.5 = 37.5$ tons = W .

This is equivalent to loads of 9.375 tons resting on each of the points G, D, and H (fig. 97).

The thrusts on the vertical posts are, therefore,

$$S_{GE} = S_{HF} = \frac{W}{4} = 9.375 \text{ tons.} \quad S_{DC} = \frac{W}{2} = 18.75 \text{ tons.}$$

Analytical Solution.—The total thrust on the boom A B is found from equation (9) by putting

$$W = 37.5 \text{ tons,} \quad l = 25 \text{ feet,} \quad d = 3.75 \text{ feet.}$$

$$S_{AB} = \frac{5 W l}{32 d} = \frac{5 \times 37.5 \times 25}{32 \times 3.75} = 39.06 \text{ tons.}$$

From equation (8) we get the stress on the primary ties—

$$S_{AC} = S_{CB} = \frac{37.5}{8 \times 3.75} \sqrt{(25)^2 + 4(3.75)^2} = 32.625 \text{ tons.}$$

The stresses on the secondary ties as found from equation (10) are—

$$S_{AE} = S_{ED} = S_{DF} = S_{BF} = \frac{37.5}{32 \times 3.75} \sqrt{(25)^2 + 16(3.75)^2} = 9.11 \text{ tons.}$$

Graphic Solution.—Through E, fig. 97, draw the vertical line $Ee = 9.375$ tons. Through e draw ee_1 parallel to ED, and meeting AE produced at e_1 . Then

$$S_{AE} = Ee_1 = 9.1 \text{ tons by scale,} \\ S_{ED} = ee_1 = 9.1 \text{ tons by scale.}$$

The stresses on the other two secondary ties; DF and FB, may be similarly found by resolving the forces acting at the point F.

To find the stresses on the primary ties, through C draw the vertical line $Cc = 18.75$ tons. Through c draw cc_1 parallel to CB, and meeting AC produced at c_1 .

$$S_{AC} = Cc_1 = 32.6 \text{ tons by scale,} \\ S_{BC} = cc_1 = 32.6 \text{ tons by scale.}$$

To find the stress on the boom AB, through e_1 draw e_1e_2 parallel to AB, then $e_1e_2 =$ stress produced in AB by the weight acting at G = 7.8 tons.

A stress of the same amount is produced in DB by the load acting at H.

The stress produced in AB by the central load of 18.75 tons, acting at D, is equal to the line c_1c_2 , which is found by drawing c_1c_2 parallel to AB. $c_1c_2 = 31.2$ tons.

We have, therefore, the total stress on the boom—

$$S_{AB} = e_1 e_2 + c_1 c_2 = 7.8 + 31.2 = 39 \text{ tons.}$$

It will be seen that these results agree with those found by the analytical method.

Example 7.—In the last example, if the right-hand half of the truss be loaded with an additional weight of 1 ton per foot, find the stresses on the truss.

Let W_1 , W_2 , W_3 be the loads resting at the points G, D, and H respectively; we have—

$$W_1 = 9.375 \text{ tons, } W_2 = 12.5 \text{ tons, } W_3 = 15.625 \text{ tons.}$$

The stresses produced in the vertical posts are—

$$S_{GE} = 9.375 \text{ tons, } S_{HF} = 15.625, \text{ and}$$

$$S_{DC} = 12.5 + \frac{1}{2}(9.375 + 15.625) = 25 \text{ tons.}$$

The stresses on the secondary ties A E and E D are the same as in the last example.

The stresses on the secondary ties D F and F B are—

$$S_{DF} = S_{FB} = \frac{W_3}{8d} \sqrt{l^2 + 16d^2} = \frac{15.625}{8 \times 3.75} \times 29.15 = 15.18 \text{ tons.}$$

The stresses on the primary ties A C and B C are—

$$\begin{aligned} S_{AC} = S_{BC} &= \left(W_2 + \frac{W_1 + W_3}{2} \right) \frac{l}{4d} \times \frac{\sqrt{l^2 + 4d^2}}{l} = \frac{25}{4 \times 3.75} \times 26.1 \\ &= 43.5 \text{ tons.} \end{aligned}$$

The total stresses on the portions A D and D B of the boom are—

$$\begin{aligned} S_{AD} &= \frac{l}{4d} \left(W_1 + W_2 + \frac{W_3}{2} \right) = \frac{25}{4 \times 3.75} (9.375 + 12.5 + 7.8125) \\ &= 49.4 \text{ tons.} \end{aligned}$$

$$\begin{aligned} S_{DB} &= \frac{l}{4d} \left(W_2 + W_3 + \frac{W_1}{2} \right) = \frac{25}{4 \times 3.75} (12.5 + 15.625 + 4.6875) \\ &= 54.7 \text{ tons.} \end{aligned}$$

Example 8.—A bridge crossing a river is 60 feet span, and is supported by two Fink trusses, each divided into eight bays of 7 feet 6 inches each; the depth being also 7 feet 6 inches. The dead load of the bridge is 40 tons. What will be the stresses

on the various members of the main trusses when the bridge is fully loaded with a train of waggons weighing $1\frac{1}{2}$ tons per foot?

Dead load on the bridge . . .	=	40 tons.
Live " " . . .	=	90 "
Total, " " . . .	=	130 "
Total load on each truss . . .	=	65 "

This is equivalent to loads of 8.125 tons resting directly over each vertical post.

We have, therefore, the following data—

$$W = 65 \text{ tons, } l = 60 \text{ feet, } d = 7.5 \text{ feet, } n = 8.$$

By means of equations from (8) to (12) we get the following results (see fig. 98)—

$$S_{44'} = \frac{W}{2} = \frac{65}{2} = 32.5 \text{ tons.}$$

$$S_{22'} = S_{66'} = \frac{W}{4} = \frac{65}{4} = 16.25 \text{ tons.}$$

$$S_{11'} = S_{33'} = S_{55'} = S_{77'} = \frac{W}{8} = 8.125 \text{ tons.}$$

$$S_{A_4'} = S_{B_4'} = \frac{W}{8d} \sqrt{l^2 + 4d^2} = \frac{65}{8 \times 7.5} \sqrt{(60)^2 + 4(7.5)^2} = 67 \text{ tons.}$$

$$S_{A_2'} = S_{42'} = S_{46'} = S_{B_2'} = \frac{W}{32d} \sqrt{l^2 + 16d^2}$$

$$= \frac{65}{32 \times 7.5} \sqrt{(60)^2 + 16(7.5)^2} = 18.15 \text{ tons.}$$

$$S_{A_1'} = S_{21'} = S_{25'} = S_{45'} = \&c. = \frac{W}{128d} \sqrt{l^2 + 64d^2}$$

$$= \frac{65}{128 \times 7.5} \sqrt{(60)^2 + 64(7.5)^2} = 5.74 \text{ tons.}$$

$$S_{A_B} = \frac{21 W l}{128 d} = \frac{21 \times 65 \times 60}{128 \times 7.5} = 85.31 \text{ tons.}$$

The above results may be checked by the resolution of forces. Thus in fig. 98 draw the verticals—

$1'a = S_{11'} = 8.125$ tons, $2'b = S_{22'} = 16.25$ tons, $4'c = S_{44'} = 32.5$ tons.

Proceeding as before explained, we get—

Stress on tertiary ties . . . = $a a_1 = 5.74$ tons by scale.

Stress on secondary ties . . . = $b b_1 = 18.15$ „

Stress on primary ties . . . = $c c_1 = 67$ „

Compressive stress on boom = $a_1 a_2 + b_1 b_2 + c_1 c_2 = 85.3$ tons.

CHAPTER XIII.

BRACED GIRDERS—*continued.*

WARREN GIRDERS.

180. Definition.—A Warren girder, called after its inventor, Captain Warren, is a braced girder of single triangulation, as shown in fig. 99, each triangle being usually equilateral, though not always so.

The horizontal members are called the flanges, and the inclined members the lattice bars or braces. The point in the flange where two braces intersect is called an *apex*. The portion of the flange, top or bottom, between two adjacent apices is called a *bay*, or sometimes a *panel*.

If a Warren girder form one of the main girders of a bridge, it is usual to have it loaded at the apices, by the cross girders resting at these points.

181. Nature of Stresses in Warren Girders.—When a Warren girder is loaded, the top flange or boom will always be exposed to a compressive stress, and the bottom flange to a tensile stress, the amount of which varies in each bay or panel. Each weight will cause either a compressive or tensile stress in each brace, and the algebraic sum of these will represent the total stress on these members.

182. Case 1—Girder supported at both Ends and loaded at an Intermediate Point.—In fig. 99—

Let l = span of girder,

d = depth of girder,

W = weight resting on an apex in the top flange,

x = distance of W from the left abutment,

θ = angle which the diagonals make with a vertical line,

a = length of one panel,

P = reaction at left abutment,

Q = reaction at right abutment.

$$P = W \frac{l-x}{l}, \quad Q = W \frac{x}{l}, \quad \tan \theta = \frac{a}{2d}.$$

These reactions represent the vertical shearing stresses on the two segments of the girder into which W divides it, and the stresses on the diagonals are equal to these shearing stresses multiplied by $\sec \theta$.

The stresses on the diagonals 1, 2, 3, 4, 5, 6, and 7 are all the same in amount but different in kind; some being compressive and some tensile, and may be thus represented—

$$S_{1 \text{ to } 7} = \pm W \frac{l-x}{l} \sec \theta.$$

The stresses on the diagonals to the right of W may be expressed thus—

$$S_{8 \text{ to } 12} = \pm W \frac{x}{l} \sec \theta.$$

The diagonals 1, 3, 5, 7, 8, 10, and 12 will be in compression;
The diagonals 2, 4, 6, 9, and 11 will be in tension.

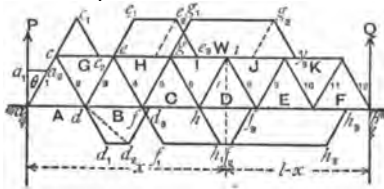

Fig. 99.

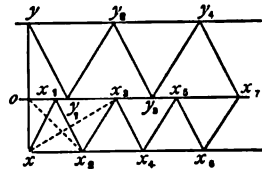

Fig. 100.

In order to explain this more thoroughly we will go through the process of resolving the forces acting along this girder, throughout its entire length.

Let us begin at the point a , at the left abutment. There are three forces acting at this point, viz. :—

- (1) The reaction of the abutment which acts vertically upwards.
- (2) The stress on the panel A.
- (3) The stress on the brace 1.

Of these three forces the first only (P) is known. Draw, therefore, the vertical line $a a_1 = P$; through a_1 draw $a_1 a_2$ parallel to A.

$a_1 a_2$ will then represent the stress on A, which is tensile, and $a a_2$ that on diagonal 1, which is compressive.

Next proceed to the point c ; here there are three forces acting, viz., the stress on diagonal 1, that on the bay G, and that on diagonal 2. Of these three the first only is known. Produce ac to c_1 , making $cc_1 = aa_2 =$ stress on 1. Through c_1 draw c_1c_2 parallel to 2.

Then $cc_2 =$ stress on G, which is compressive,
and $c_1c_2 =$ stress on 2, which is tensile.

Next consider the forces acting at the point d . These are four in number, viz., the stresses on the bays A and B, and on the diagonals 2 and 3. Of these, the stresses on A and 2 are known, and the other two unknown; we can find these latter as there are only two unknown forces. Produce diagonal 2 to d_1 , making $dd_1 = S_2 = c_1c_2$. Draw d_1d_2 parallel to A and equal to $a_1a_2 = S_A$. The diagonal dd_2 will represent the force which balances these two forces, and it must also be equal to the resultant of the two unknown forces. Draw, therefore, d_2d_3 parallel to 3, then

$dd_2 = S_3$, which is compressive,
 $d_2d_3 = S_B$, which is tensile.

In the same manner, by considering the four forces acting at the point e , two of which are known, we can find the others, viz. :—

$e_2e_3 = S_4$, which is tensile,
 $ee_3 = S_H$, which is compressive.

Similarly, by resolving the forces acting at the points f, g, h , &c., taken in succession, the stresses on all the members of the girder may be graphically found. We have, therefore, the following results :—

The stresses on all the diagonals to the left of $W = \pm P \sec \theta$.

$$S_A = a_1 a_2 = P \tan \theta = \frac{1}{2} P \cdot \frac{a}{d}$$

$$S_G = c c_2 = 2 a_1 a_2 = 2 P \tan \theta = P \cdot \frac{a}{d}$$

$$S_B = d d_3 = 3 a_1 a_2 = 3 P \tan \theta = \frac{3}{2} P \cdot \frac{a}{d}$$

$$S_H = e e_3 = 4 a_1 a_2 = 4 P \tan \theta = 2 P \cdot \frac{a}{d}$$

$$S_C = f f_3 = 5 a_1 a_2 = 5 P \tan \theta = \frac{5}{2} P \cdot \frac{a}{d}$$

$$S_I = g y_3 = 6 a_1 a_2 = 6 P \tan \theta = 3 P \cdot \frac{a}{d}$$

$$S_D = h h_3 = 7 a_1 a_2 = 7 P \tan \theta = \frac{7}{2} P \cdot \frac{a}{d}$$

In the same way, by commencing at the right-hand abutment and working back to the point of application of the weight W , it may be shown that the stresses on all the diagonals to the right of $W = \pm Q \sec \theta$.

$$S_F = Q \tan \theta = \frac{1}{2} Q \cdot \frac{a}{d}$$

$$S_K = 2 Q \tan \theta = Q \cdot \frac{a}{d}$$

$$S_E = 3 Q \tan \theta = \frac{3}{2} Q \cdot \frac{a}{d}$$

$$S_J = 4 Q \tan \theta = 2 Q \cdot \frac{a}{d}$$

$$S_D = 5 Q \tan \theta = \frac{5}{2} Q \cdot \frac{a}{d}$$

The stresses in the flanges may be checked by the principle of moments.

Taking moments about the apices c, d, e, f , &c., in succession, we get the following results:—

$$S_A \times d = P \times \frac{a}{2}, \text{ or } S_A = \frac{1}{2} P \cdot \frac{a}{d} = P \tan \theta.$$

$$S_G \times d = P \times a, \text{ or } S_G = P \cdot \frac{a}{d} = 2 P \tan \theta.$$

$$S_B \times d = P \times \frac{3a}{2}, \text{ or } S_B = \frac{3}{2} P \cdot \frac{a}{d} = 3 P \tan \theta,$$

and so on.

It will be seen that these results correspond with those as found by the resolution of forces.

Instead of resolving the forces in the manner explained, it will

generally be found more convenient in girders of this description to construct a separate stress diagram, on the principles explained by Professor Clerk Maxwell.

A diagram of this description is shown in fig. 100, and may be constructed as follows:—

Take a vertical line, $y x$, on any scale of forces, to represent the weight W ; let $o x$ represent P , and $o y$ represent Q . Through x , o , and y draw lines parallel to the flanges of the girder. Commencing at the left abutment, through x draw $x x_1$ parallel to diagonal 1; then $o x_1 = S_A$, and $x x_1 = S_1$. As $x x_1$ is the resultant of the stresses on diagonal 2 and bay G, by drawing $x_1 x_2$ parallel to 2, and $x x_2$ parallel to G, we get $x_1 x_2$ = stress on diagonal 2, and $x x_2$ = stress on bay G. The dotted line $o x_2$ is the resultant, in magnitude, of S_A and S_2 , and it is also the resultant of the stresses on diagonal 3 and bay B. Through its extremities, o and x_2 , draw $o x_3$ and $x_2 x_3$ parallel respectively to B and 3, then $o x_3 = S_B$, and $x_2 x_3 = S_3$. Again the dotted line $x x_3$ is the resultant of the stresses in G and 3, and it is also the resultant of the stresses on bay H and diagonal 4. By drawing $x x_4$ parallel to H, and $x_3 x_4$ parallel to 4, we get—

$$x x_4 = S_H, \text{ and } x_3 x_4 = S_4.$$

Proceeding in this manner throughout, we get—

$$o x_5 = S_C, \quad o x_7 = S_D, \quad x_3 x_4 = S_4, \quad x_4 x_5 = S_5, \quad x_5 x_6 = S_6, \quad x_6 x_7 = S_7.$$

Having thus found the stresses on all the members to the left of W , we can next find the stresses on the members to the right by drawing $y y_1$ parallel to 12, and proceeding exactly as before, when we get—

$$\begin{array}{llll} y y_1 = S_{12}, & y_1 y_2 = S_{11}, & y_2 y_3 = S_{10}, & y_3 y_4 = S_9 \\ y_4 x_7 = S_8, & o y_1 = S_F, & o y_3 = S_E, & o x_7 = S_D, \\ & y y_2 = S_K, & y y_4 = S_J, & \end{array}$$

As a check on the accuracy of the diagram, the last line drawn, viz., $y_4 x_7$, should exactly meet at the point x_7 .

183. Bow's Method of Lettering the Parts of Figures.—In his *Economics of Construction*, Mr. R. H. Bow has introduced a new method of lettering the parts of a truss, and of its reciprocal diagram, which possesses advantages of simplicity, especially when the reciprocal diagram is complicated. By this system it is easy to tell at a glance what line on the stress diagram represents the stress on any member of the truss. Mr. Bow remarks, "This plan of lettering consists in assigning a particular letter to

each enclosed area or space *in*, and also to each space (enclosed or not) *around* or bounding the truss, and attaching the same letter to the angle or point of concurrence of lines which represent the area in the diagram of forces. Any linear part of the truss, or any line of action of an external force applied to it, is to be named from the two letters belonging to the two spaces it separates; and the corresponding line in the reciprocal diagram of forces, which represents the force acting in that part or line, will have its *extremities* defined by the same two letters."

This method of lettering is illustrated in figs. 101 and 102, which represent a similar truss and stress-diagram to those shown in figs. 99 and 100. The letters A, B, C, D, . . . K, fig. 101, are assigned to the spaces *in*, and the letters X, Y, and O to those *around* the truss. The designation of the diagonals corresponding to 1, 2, 3, . . . 12, in fig. 99, will, according to this system, be X A, A B, B C, C D, D E, E F, F G, G H, H I, I J, J K, and K Y respectively. The designation of the top bays proceeding from the left abutment will be X B, X D, X F, Y H, Y J, and those of the bottom bays proceeding from the left abutment will be O A, O C, O E, O G, O I, and O K.

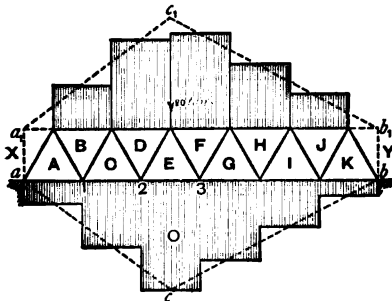

Fig. 101.

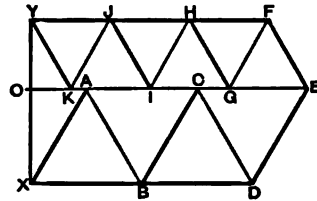

Fig. 102.

The line in the diagram fig. 102 representing the stress on any member of the truss will have the same letters attached to its extremities as those which designate the member of the truss.

Thus the stress on diagonal X A is represented by the line X A in the diagram, that on A B by A B, and so on.

In the same way the stresses on the bays X B, X D, &c., are represented by the lines X B, X D, &c., in the diagram.

The convenience of this notation will be at once apparent.

Example 1.—A Warren girder with six equal bays in the bottom flange is 90 feet span and 13 feet deep, and is loaded

with a weight of 20 tons resting on an apex of the top flange 37 feet 6 inches from the left abutment. Determine the stresses on the diagonals and flanges of the girder.

Analytical Solution—

$$l = 90 \text{ feet, } d = 13 \text{ feet, } x = 37.5, \quad a = 15, \quad W = 20 \text{ tons,}$$

$$\theta = 30^\circ, \quad \sec \theta = 1.15.$$

$$\text{Reaction of left abutment} = \frac{20 \times 52.5}{90} = 11.66 \text{ tons.}$$

$$\text{Reaction of right } \quad \quad \quad = \frac{20 \times 37.5}{90} = 8.33 \text{ tons.}$$

Stresses on diagonals to the left of weight—

$$= 11.66 \times \sec \theta = 11.66 \times 1.15 = 13.4 \text{ tons.}$$

These stresses will be compressive and tensile alternately.

Stresses on diagonals to the right of weight = $8.33 \sec \theta = 9.58$ tons, which will also be compressive and tensile alternately.

The stresses on the bays of the top flange taken in order from the left, and adopting Bow's notation (see fig. 101), are—

$$S_{XB} = P \times \frac{a}{d} = 13.46 \text{ tons.}$$

$$/ \quad S_{XD} = 2 P \times \frac{a}{d} = 26.92 \text{ tons.}$$

$$/ \quad S_{YF} = 3 Q \times \frac{a}{d} = 28.86^5 \text{ tons.}$$

$$; \quad S_{YH} = 2 Q \times \frac{a}{d} = 19.24^3 \text{ tons.}$$

$$S_{XZ} = Q \times \frac{a}{d} = 9.62 \text{ tons.}$$

The stresses on the bays of the bottom flange are—

$$S_{oA} = \frac{1}{2} P \times \frac{a}{d} = 6.73 \text{ tons.}$$

$$S_{oC} = \frac{3}{2} P \times \frac{a}{d} = 20.2 \text{ tons.}$$

$$S_{oE} = \frac{5}{2} P \times \frac{a}{d} = 33.65 \text{ tons.}$$

$$S_{oG} = \frac{5}{2} Q \times \frac{a}{d} = 24.07^4 \text{ tons.}$$

$$S_{O_I} = \frac{3}{2} Q \times \frac{a}{d} = 14.4\frac{1}{2} \text{ tons.}$$

$$S_{O_K} = \frac{1}{2} Q \times \frac{a}{d} = 4.81 \text{ tons.}$$

The stresses on the bays may be got more directly by the principle of moments, as explained in Chap. IV., Art. 56. Thus, for example, to find the stress on O E, take moments round the apex where W rests, and considering the left portion of girder, we get

$$S_{O_E} \times 13 = P \times 37.5,$$

$$\text{or } S_{O_E} = \frac{11.66 \times 37.5}{13} = 33.65 \text{ tons,}$$

which agrees with that already found.

Graphic Solution.—In fig. 102, which is drawn to scale, take the vertical line Y X = 20 tons, the portion O X being = 11.66 tons the reaction of the left abutment, and O Y = 8.33 tons the reaction of the right abutment, and construct the diagram in the manner already explained.

By scaling the lines in the diagram, the stresses on the various members of the truss may be found, and it will be seen that they correspond with those as determined by the analytical method.

The shaded portion in fig. 101 represents graphically the stresses on the flanges; the ordinates of this diagram being drawn to a smaller scale than that adopted in fig. 102.

If the web of the girder be a continuous plate instead of lattice bars, the flange stresses would be represented by the ordinates of the triangles $a c b$ and $a_1 c_1 b_1$.

If the weight rest on the bottom flange instead of the top, the method of calculating the stresses both by moments and also by the stress diagram will be similar to that described.

Example 2.—If, in the last example, a load of 20 tons be suspended at the points 1, 2, and 3 on the bottom flange in succession, find the stresses on each member of the girder. Find also the stresses when a weight of 20 tons is suspended from each of these points simultaneously, or a total weight of 60 tons.

This is a useful example for the student to work out; he should draw stress diagrams for each case. It is evident that when the three weights are suspended simultaneously the stresses will be the algebraic sum of those due to each weight taken separately. Table XXXIII. gives the required stresses.

TABLE XXXIII.

Bays.	STRESS ON BOOMS.				Loads at 1, 2, and 3. Tons.	Braces.	STRESS ON DIAGONALS.				Loads at 1, 2, and 3. Tons.
	Load at 1.	Load at 2.	Load at 3.	Load at 1.			Load at 2.	Load at 3.			
	Tons.	Tons.	Tons.	Tons.			Tons.	Tons.			
A O	- 9.6	- 7.7	- 5.76	- 23.06	X A	+ 19.2	+ 15.4	+ 11.52	+ 46.12		
R X	+ 19.2	+ 15.4	+ 11.52	+ 46.12	A B	- 19.2	- 15.4	- 11.52	- 46.12		
C O	- 17.28	- 23.1	- 17.28	- 57.66	B C	- 3.84	+ 15.4	+ 11.52	+ 23.06		
D X	+ 15.36	+ 30.72	+ 23.04	+ 69.12	C D	+ 3.84	- 15.4	- 11.52	- 23.06		
E O	- 13.44	- 26.88	- 26.8	- 69.12	D E	- 3.84	- 7.7	+ 11.52	0		
F Y	+ 11.52	+ 23.04	+ 34.56	+ 69.12	E F	+ 3.84	+ 7.7	- 11.52	0		
G O	- 9.6	- 19.2	- 26.8	- 57.6	F G	- 3.84	- 7.7	- 11.52	- 23.06		
H Y	+ 7.68	+ 15.36	+ 23.04	+ 46.08	G H	+ 3.84	+ 7.7	+ 11.52	+ 23.06		
I O	- 5.76	- 11.52	- 17.28	- 34.56	H I	- 3.84	- 7.7	- 11.52	- 23.06		
J Y	+ 3.84	+ 7.68	+ 11.52	+ 23.04	I J	+ 3.84	+ 7.7	+ 11.52	+ 23.06		
K O	- 1.92	- 3.84	- 5.76	- 11.52	J K	- 3.84	- 7.7	- 11.52	- 23.06		
					K Y	+ 3.84	+ 7.7	+ 11.52	+ 23.06		

184. Warren Girder Uniformly Loaded.—Suppose the load to rest on the bottom flange of the girder, as shown in fig. 103—

Let n = number of bays in the bottom flange of girder,

P = load on each bay,

θ = angle which diagonals make with a vertical line,

nP = total load on girder = W .

If the load be uniformly distributed along the bottom flange it will be equivalent to a weight P resting on each bottom apex.

As half the loads on the bays adjacent to the abutments will be carried directly by the abutments themselves there will be $(n-1)$ points on the girder upon each of which a weight P rests. Consequently, reaction at each abutment

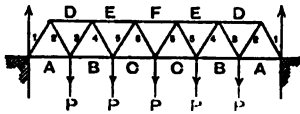

Fig. 103.

$$= \frac{n-1}{2} P.$$

With this distribution of load the stresses on the diagonals increase *pro rata* from the centre, where they are a minimum, to the ends, where they are a maximum.

Any two diagonals equidistant from the centre will be subjected to stresses of the same intensity and of the same kind, and the stress on each will be equal to the load between it and the centre multiplied by $\sec \theta$.

The stress on diagonals 1 and 2 = $\frac{n-1}{2} P \sec \theta$,

„ „ 3 and 4 = $\frac{n-3}{2} P \sec \theta$,

„ „ 5 and 6 = $\frac{n-5}{2} P \sec \theta$,

and so on.

The stresses on the bays of the flanges are a maximum at the centre, and gradually decrease towards the ends. They may be found most conveniently by taking moments about each apex in succession.

Thus to find the stress on the bay A, take moments about the first apex on the top flange, and putting

a = length of each bay, d = depth of girder, $\tan \theta = \frac{a}{2d}$

we get—

$$S_A \times d = \frac{n-1}{2} P \times \frac{a}{2}, \text{ or } S_A = \frac{n-1}{2} P \tan \theta.$$

Similarly, we may find the stresses on the other bays—

$$S_D \times d = \frac{n-1}{2} P \times a, \text{ or } S_D = (n-1) P \tan \theta,$$

$$S_B \times d = \frac{n-1}{2} P \times \frac{3a}{2} - P \times \frac{a}{2}, \text{ or } S_B = \frac{3n-5}{2} \cdot P \tan \theta,$$

$$S_E \times d = \frac{n-1}{2} P \times 2a - P \times a, \text{ or } S_E = 2(n-2) P \tan \theta,$$

$$S_C \times d = \frac{n-1}{2} P \times \frac{5a}{2} - P \left(\frac{a}{2} + \frac{3a}{2} \right), \text{ or } S_C = \frac{5n-13}{2} \cdot P \tan \theta,$$

$$S_F \times d = \frac{n-1}{2} P \times 3a - P(a+2a), \text{ or } S_F = 3(n-3) P \tan \theta,$$

and so on.

For the truss shown in fig. 103, $n = 6$.

The following table gives a summary of the stresses in this girder.

The general equation for finding the flange stress at the centre of a girder of span l and depth d , loaded uniformly with a load W , is $S = \frac{Wl}{8d}$. In this equation, by putting

$$W = 6P, \quad l = 6a, \quad \frac{a}{d} = \tan \theta, \text{ we get—}$$

$$S_{\text{cen.}} = \frac{6P \times 6}{4} \times \frac{a}{2d} = 9P \tan \theta,$$

which agrees with the stress on the centre bay, as given in the table.

TABLE XXXIIIa.

Diagonals,	1	2	3	4	5	6
Stresses,	$+\frac{5P}{2} \sec \theta$	$-\frac{5P}{2} \sec \theta$	$+\frac{3}{2} P \sec \theta$	$-\frac{3}{2} P \sec \theta$	$+\frac{P}{2} \sec \theta$	$-\frac{P}{2} \sec \theta$
Flanges,	A	D	B	E	C	F
Stresses,	$-\frac{5}{2} P \tan \theta$	$+5 P \tan \theta$	$-\frac{13}{2} P \tan \theta$	$+8 P \tan \theta$	$-\frac{17}{2} P \tan \theta$	$+9 P \tan \theta$

It will be noticed that when two diagonals intersect at a loaded apex of a Warren girder uniformly loaded, the stress in the

diagonal further from the centre exceeds that in the other diagonal by $P \sec \theta$, where P is the load on the apex; and further, that when two diagonals intersect on an unloaded apex, no matter whether the load is equally distributed or not, the stresses in the diagonals are equal in amount but of opposite kind; that is, one is compressive and the other tensile.

Example 3.—A Warren girder similar to that shown in fig. 104 is 60 feet span and divided into 11 equilateral triangles; a load

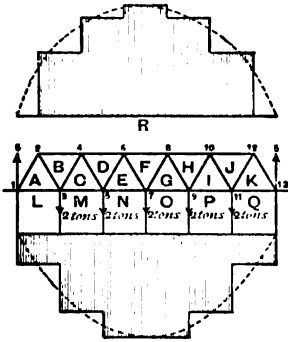

Fig. 104.

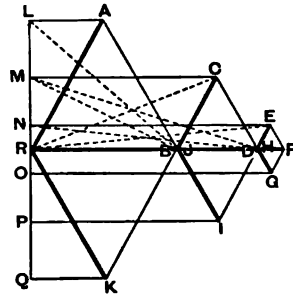

Fig. 105.

of 2 tons is suspended from each of the bottom apices. Write down a table of the stresses on the different members, and verify the result by means of a stress diagram.

$$P = 2 \text{ tons}, \quad \theta = 30^\circ, \quad \sec \theta = 1.154, \quad \tan \theta = 0.577.$$

Substituting these values in the last table, we get the following table of stresses:—

TABLE XXXIIIb.

Diagonals, .	RA	AB	BC	CD	DE	EF
	Tons.	Tons.	Tons.	Tons.	Tons.	Tons.
Stresses, .	+5.77	-5.77	+3.46	-3.46	+1.15	-1.15
Flanges, .	AL	CM	EN	BR	DR	FR
	Tons.	Tons.	Tons.	Tons.	Tons.	Tons.
Stresses, .	-2.88	-7.5	-9.8	+5.77	+9.23	+10.38

Stress Diagram.—Fig. 104 represents the girder lettered according to Bow's method, with the addition that figures are

put at each of the apices for the purpose of more fully explaining the diagram.

At the apices 3, 5, 7, 9, and 11 are suspended weights of 2 tons; the upward reactions of the abutments 1 and 13 are 5 tons.

In fig. 105, which represents the stress diagram drawn to scale, take the vertical line $LQ = 10$ tons, the total weight on the girder. Set off LM , MN , NO , OP , and PQ , each equal to 2 tons, and make $LR = RQ = 5$ tons. LR will then represent the upward reaction of the left abutment, and RQ that of the right.

By drawing LA and RA parallel to LA and RA respectively in fig. 104 these two lines will represent graphically the stresses on the first bay and the first diagonal of the girder.

By scaling them, we get—

$$\begin{aligned} S_{AL} &= AL = -2.88 \text{ tons,} \\ S_{RA} &= RA = +5.77 \text{ tons.} \end{aligned}$$

The next apex in the girder for resolving the forces is 2, at which point three forces act, one of which is known, namely, the stress on RA . This stress is the resultant in point of magnitude of the stresses on the other two members. In the diagram draw, therefore, RB , AB parallel respectively to the corresponding members of the girder; these two lines will represent the stresses on the members.

By scaling, we get—

$$\begin{aligned} S_{RB} &= RB = +5.77 \text{ tons,} \\ S_{AB} &= AB = -5.77 \text{ tons.} \end{aligned}$$

Next take the apex 3. At this point there are five forces acting, viz. :—The stresses on the bays AL and CM , and those on the diagonals AB and BC , and also the vertical weight of 2 tons. All these forces are known except two, which we now proceed to find. The dotted line BL represents the resultant of the stresses on the bay AL and the diagonal AB . Combining this resultant with the vertical load of 2 tons, which is represented by LM in the diagram, we get the resultant of the three known forces, which is represented by the dotted line BM . Resolving this resultant in the direction of the two unknown stresses by drawing MC parallel to the bay MC , and BC parallel to the

diagonal B C, we get the lines so drawn to represent the stresses on these members, and by measuring we get—

$$\begin{aligned} S_{M C} &= M C = -7.5 \text{ tons,} \\ S_{B C} &= B C = +3.46 \text{ tons.} \end{aligned}$$

Next proceed to apex 4. The dotted line R C represents the resultant of the two known stresses, R B and B C; and drawing C D parallel to the diagonal C D, and R D parallel to the bay R D, we get—

$$\begin{aligned} S_{R D} &= R D = +9.23 \text{ tons,} \\ S_{C D} &= C D = -3.46 \text{ tons.} \end{aligned}$$

The forces acting at the apex 5 are, like those at 3, five in number, and are treated in the same way. The dotted line M D in the diagram represents the resultant of the stresses on the bay M C and the diagonal C D, and the dotted line N D represents the resultant of this latter resultant combined with the vertical load of 2 tons. Resolving the resultant N D in directions parallel to the two unknown forces, by drawing N E parallel to the bay N E, and D E parallel to the diagonal D E, we get—

$$\begin{aligned} S_{N E} &= N E = -9.8 \text{ tons,} \\ S_{D E} &= D E = +1.15 \text{ tons.} \end{aligned}$$

The dotted line R E in the diagram represents the resultant of the stresses on the bay R F and the diagonal E F. Draw E F parallel to E F, meeting the line through R parallel to the bay R F at the point F, then we get—

$$\begin{aligned} S_{R F} &= R F = +10.38 \text{ tons,} \\ S_{E F} &= E F = -1.15 \text{ tons.} \end{aligned}$$

The portion of the diagram above the line R F represents the stresses on the left half of the girder as just explained; and it will be noticed that these stresses agree with those given in the table. The stresses on the second half of the girder are exactly the same as those on the first half, and are graphically represented by the portion of the diagram below the line R F. This may be constructed in exactly the same way as the upper portion, by starting at the point R and drawing R K parallel to the diagonal R K, and Q K parallel to the bay Q K, and proceeding

in the manner explained; the last line drawn will be G F, and, as a proof of the accuracy of the diagram, this line should exactly intersect the line R F at F.

The lower portion of the diagram may also be constructed by commencing where we left off in the upper portion, namely, at the point F, and proceeding backwards; in which case the last line of the diagram, namely, K R, should exactly intersect the horizontal line in the point R.

The thick lines of the diagram represent the compressive stresses, and the thin ones the tensile stresses.

The shaded portion of fig. 104 represents graphically the flange stresses on the girder. The dotted lines obtained by joining the centres of each step are parabolic curves.

Another method which might be adopted for finding the stresses on the diagonals, is to consider each weight in succession and find the stress which it produces on each diagonal; then the total stress on each brace is equal to the algebraic sum of the stresses produced on it by each load.

Calling the weights applied at 3, 5, 7, 9, and 11, P_1 , P_2 , P_3 , P_4 , and P_5 respectively, Table XXXIV. will explain this method as applied to the last example.

TABLE XXXIV.

Diagonals.	P_1 .	P_2 .	P_3 .	P_4 .	P_5 .	Stress due to Total Load.
	Tons.	Tons.	Tons.	Tons.	Tons.	Tons.
R A	+1.92	+1.54	+1.15	+0.77	+0.38	+5.76
A B	-1.92	-1.54	-1.15	-0.77	-0.38	-5.76
B C	-0.38	+1.54	+1.15	+0.77	+0.38	+3.46
C D	+0.38	-1.54	-1.15	-0.77	-0.38	-3.46
D E	-0.38	-0.77	+1.15	+0.77	+0.38	+1.15
E F	+0.38	+0.77	-1.15	-0.77	-0.38	-1.15

Example 4.—The Warren girder, shown in fig. 106, is 90 feet span and 7 feet 6 inches deep. It is divided into six bays of 15 feet each, thus forming a series of right-angled isosceles triangles. Three weights of 5, 8, and 12 tons rest on the top

flange at the 1st, 3rd, and 5th apices respectively from the left abutment. Investigate the stresses on the various members.

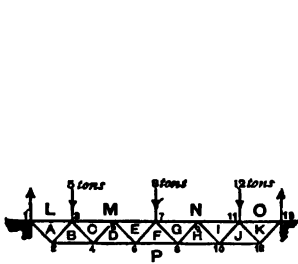

Fig. 106.

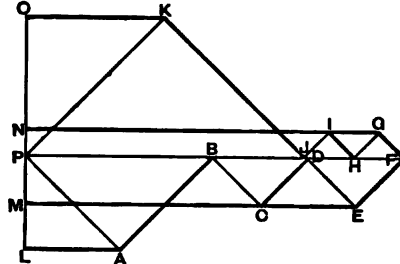

Fig. 107.

Analytical Solution—Stresses on Flanges.—The stresses on the flange bays may be calculated by the method of moments.

$$\text{Reaction at left abutment} = 10.16 \text{ tons.}$$

$$\text{Reaction at right abutment} = 14.83 \text{ tons.}$$

Taking moments about each of the apices in succession, starting from the left, we get the following:—

$$\begin{array}{ll} S_{AL} \times 7.5 = 10.16 \times 7.5, & \text{or } S_{AL} = + 10.16 \text{ tons,} \\ S_{BF} \times 7.5 = 10.16 \times 15, & \text{or } S_{BF} = - 20.33 \text{ tons,} \\ S_{CM} \times 7.5 = 10.16 \times 22.5 - 5 \times 7.5, & \text{or } S_{CM} = + 25.5 \text{ tons,} \\ S_{DF} \times 7.5 = 10.16 \times 30 - 5 \times 15, & \text{or } S_{DF} = - 30.66 \text{ tons,} \\ S_{EM} \times 7.5 = 10.16 \times 37.5 - 5 \times 22.5, & \text{or } S_{EM} = + 35.83 \text{ tons,} \\ S_{FF} \times 7.5 = 10.16 \times 45 - 5 \times 30, & \text{or } S_{FF} = - 41.0 \text{ tons,} \\ S_{GN} \times 7.5 = 14.83 \times 37.5 - 12 \times 22.5, & \text{or } S_{GN} = + 38.16 \text{ tons,} \\ S_{HF} \times 7.5 = 14.83 \times 30 - 12 \times 15, & \text{or } S_{HF} = - 35.33 \text{ tons,} \\ S_{IN} \times 7.5 = 14.83 \times 22.5 - 12 \times 7.5, & \text{or } S_{IN} = + 32.5 \text{ tons,} \\ S_{JP} \times 7.5 = 14.83 \times 15, & \text{or } S_{JP} = - 29.6 \text{ tons,} \\ S_{OK} \times 7.5 = 14.83 \times 7.5, & \text{or } S_{OK} = + 14.83 \text{ tons.} \end{array}$$

Stresses on Webs.—The simplest analytical method of determining the stresses on the diagonal braces is to find the stress for each weight acting separately, and then add or subtract the different stresses, as the case may be, in order to find the total stresses. This is done in detail in Table XXXV.

$$\theta = 45^\circ, \sec \theta = 1.414.$$

TABLE XXXV.

Diagonal.	Stress from load of 5 tons.	Stress from load of 8 tons.	Stress from load of 12 tons.	Stress from total load.
	Tons.	Tons.	Tons.	Tons.
A P	-5.88	-5.65	-2.82	-14.35
A B	+5.88	+5.65	+2.82	+14.35
B C	+1.17	-5.65	-2.82	-7.3
C D	-1.17	+5.65	+2.82	+7.3
D E	+1.17	-5.65	-2.82	-7.3
E F	-1.17	+5.65	+2.82	+7.3
F G	+1.17	+5.65	-2.82	+4.0
G H	-1.17	-5.65	+2.82	-4.0
H I	+1.17	+5.65	-2.82	+4.0
I J	-1.17	-5.65	+2.82	-4.0
J K	+1.17	+5.65	+14.14	+20.96
K P	-1.17	-5.65	-14.14	-20.96

Stress Diagram.—Take the vertical line O L (fig. 107) = 25 tons, the total weight on the girder, set off O N = 12 tons, N M = 8 tons, and M L = 5 tons. Take the point P so that P O = reaction of right abutment = 14.83 tons, and P L = reaction of left abutment = 10.16 tons. The stress diagram is constructed as already explained.

185. *Semi-Girders Loaded at their Extremities.*—Fig. 108 represents a cantilever of the Warren girder type, one end of which is fixed to a wall or other support; and from the other extremity *a*, a weight *W* is suspended. At the point *a* there are three forces meeting, namely, the stresses on *ba* and *ac*, and the vertical weight *W*. Draw the vertical line *aa*₁ to represent the weight *W*; through *a*₁ draw *a*₁*a*₂ parallel to *ac* meeting *ba* produced in *a*₂; the lines *aa*₂ and *a*₁*a*₂ will then represent the stresses on the diagonal *ba* and the bay *ca*, the first being tensile and the latter compressive.

If θ = angle which a diagonal makes with the vertical, we get—

$$S_{a,b} = a a_2 = W \sec \theta,$$

$$S_{a,c} = a_1 a_2 = W \tan \theta.$$

If we continue the process of resolving the forces at the different apices $b, c, d, \&c.$, taken in succession (as explained in Art. 182), we can find the stresses on all the members. It will be found that those on the diagonals are equal in amount but of

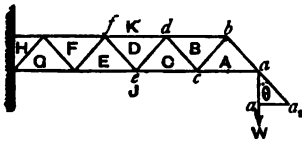

Fig. 108.

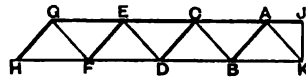

Fig. 109.

different sign. It will also be seen that at each apex the flanges receive successive increments of stress = $2 W \tan \theta$, and also that the stress on the first bay of the top flange = $2 W \tan \theta$. This being so, the stresses on the bays of the top flange, commencing at the right-hand end, are—

$$2 W \tan \theta, - 4 W \tan \theta, - 6 W \tan \theta, \&c.,$$

and those on the bottom flange are—

$$+ W \tan \theta, + 3 W \tan \theta, + 5 W \tan \theta, \&c.,$$

so that if n = number of the diagonals between any bay and the weight, the stress on that bay = $\pm n W \tan \theta$.

The general expression for the stresses on the diagonals is

$$S_{diag.} = \pm W \sec \theta.$$

Example 5.—A cantilever similar to that shown in fig. 108 is 16 feet long and 2 feet 3 inches deep. It is loaded with a weight of 20 tons at its extremity. What are the stresses on the different members? Verify the result by means of a stress diagram.

$$l = \text{length of cantilever} = 16 \text{ feet,}$$

$$l_1 = \text{length of each bay} = 4 \text{ feet,}$$

$$d = \text{depth of girder} = 2.25 \text{ feet,}$$

$$W = \text{weight at end} = 20 \text{ tons,}$$

$$\tan \theta = \frac{2}{2.25} = 0.888, \text{ or } \theta = 41^\circ 38',$$

$$\sec \theta = 1.338.$$

This is an example of a girder in which the lattices do not make a common angle with the vertical.

Stress on lattices = $\pm W \sec \theta = \pm 20 \times 1.338 = \pm 26.76$ tons,

$$\begin{aligned} S_{AJ} &= W \tan \theta = +17.77 \text{ tons,} \\ S_{BK} &= 2 W \tan \theta = -35.55 \text{ tons,} \\ S_{CJ} &= 3 W \tan \theta = +53.33 \text{ tons,} \\ S_{DK} &= 4 W \tan \theta = -71.10, \\ S_{EJ} &= 5 W \tan \theta = +88.88, \\ S_{FK} &= 6 W \tan \theta = -106.66, \\ S_{GJ} &= 7 W \tan \theta = +124.44, \\ S_{HK} &= 8 W \tan \theta = -142.20. \end{aligned}$$

Stress Diagram.—In fig. 109 take the vertical line JK to represent 20 tons. Draw JA parallel to the bay AJ, and KA parallel to the diagonal AK; then these lines will represent the stresses on these members, and scaling them, we get—

$$\begin{aligned} S_{AJ} &= AJ = +17.7 \text{ tons,} \\ S_{KA} &= KA = -26.7 \text{ tons.} \end{aligned}$$

The further construction of the diagram is carried out in the usual way, and the stresses on the different members of the girder are represented by the lines similarly lettered. It will be found by scaling these stress lines that they give the same results as previously found.

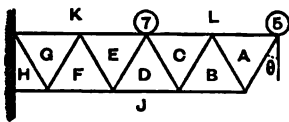

Fig. 110.

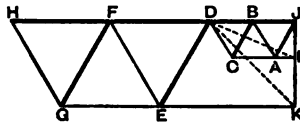

Fig. 111.

Example 6.—The cantilever shown in fig. 110 is composed of equilateral triangles, a side of each triangle being 8 feet. A load of 5 tons rests on the extremity of the top flange and a weight of 7 tons at the centre. Determine the stresses on the girder.

$$\begin{aligned} \theta &= 30^\circ, \sec \theta = 1.154, \tan \theta = 0.577, \\ d &= \text{depth of girder} = \sqrt{8^2 - 4^2} = 6.93 \text{ feet.} \end{aligned}$$

The stresses on the members to the right of the load of 7 tons are not affected by this weight.

The stresses on the four diagonals to the right of the central

load are each equal to $\pm 5 \times \sec \theta = \pm 5.77$ tons, the stresses on A J and B C being compressive and those on B A and D C being tensile.

The stresses on the diagonals to the left of the central load are each equal to $\pm (7 + 5) \sec \theta = \pm 13.848$ tons, those on E D and G F being compressive, and those on F E and H G being tensile.

The stress on the flanges may be most conveniently determined by taking moments about the apices in succession, from which we find—

$$\begin{array}{ll} S_{A L} \times d = 5 \times 4, & \text{or } S_{A L} = - 2.88 \text{ tons,} \\ S_{B J} \times d = 5 \times 8, & \text{or } S_{B J} = + 5.77 \text{ tons,} \\ S_{C L} \times d = 5 \times 12, & \text{or } S_{C L} = - 8.66 \text{ tons,} \\ S_{D J} \times d = 5 \times 16, & \text{or } S_{D J} = + 11.55 \text{ tons,} \\ S_{E K} \times d = 5 \times 20 + 7 \times 4, & \text{or } S_{E K} = - 18.47 \text{ tons,} \\ S_{F J} \times d = 5 \times 24 + 7 \times 8, & \text{or } S_{F J} = + 25.4 \text{ tons,} \\ S_{G K} \times d = 5 \times 28 + 7 \times 12, & \text{or } S_{G K} = - 32.32 \text{ tons,} \\ S_{H J} \times d = 5 \times 32 + 7 \times 16, & \text{or } S_{H J} = + 39.25 \text{ tons.} \end{array}$$

Stress Diagram.—Fig. 111 is the stress diagram for this girder, and may be constructed as follows:—On a vertical line set off J L = 5 tons and L K = 7 tons. The diagram of stresses for the right half of the girder is constructed in the manner explained in the last example. When we reach the centre apex of the girder on which the load of 7 tons rests we find that there are five forces acting, namely, the stresses in the two diagonals, those on the two bays meeting at the apex, and also the vertical load of 7 tons. The dotted line D L represents the resultant of the stresses on the diagonal D C and the bay C L; and the dotted line D K represents the resultant of the stresses on these two members, and the vertical load of 7 tons; through its extremities draw D E parallel to the diagonal D E and K E parallel to the bay K E, these two lines will then represent the stresses on the two members. The remainder of the diagram does not need further explanation.

186. Cantilever Loaded Uniformly.—The bottom flange of the cantilever shown in fig. 112 is loaded with a uniformly distributed weight of P resting on each panel.

This load may be supposed to be suspended from each apex of the bottom flange, in the manner shown. The end apex carries only half the load on the panel, or $\frac{1}{2}$ P.

Stresses on Diagonals.—If each weight be supposed to act

alone it will produce stresses equal in amount, but of opposite sign, on all the diagonals between its point of application and the abutment; and the amount of this stress is equal to the weight multiplied by the secant of the angle of inclination of the diagonal to a vertical line.

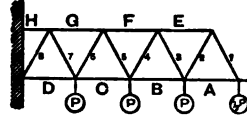

Fig. 112.

Thus the weight $\frac{1}{2} P$ produces a stress $= \pm \frac{1}{2} P \sec \theta$ on all the diagonals of the cantilever. The next weight produces a stress of $\pm P \sec \theta$ on diagonals 3, 4, 5, 6, 7, and 8. The third weight produces a stress $= \pm P \sec \theta$ on the diagonals 5, 6, 7, and 8, and so on. The diagonals to the right of a weight are not affected by it. Consequently, when all the weights act simultaneously on the girder, the total stress on any diagonal is obtained by adding together the stresses due to each individual weight when acting alone.

Table XXXVI. gives the stresses on the diagonals.

TABLE XXXVI.

Diagonals,	1	2	3	4	5	6	7	8
Stresses,	$-\frac{P}{2} \sec \theta$	$+\frac{P}{2} \sec \theta$	$-\frac{3P}{2} \sec \theta$	$+\frac{3P}{2} \sec \theta$	$-\frac{5}{2} P \sec \theta$	$+\frac{6}{2} P \sec \theta$	$-\frac{7}{2} P \sec \theta$	$+\frac{7}{2} P \sec \theta$

Generally speaking, if n = number of the weights, P , between any diagonal and the free end of the cantilever, the stress on that diagonal is represented by

$$S_{diag.} = n P \sec \theta.$$

Thus, for diagonal 6,

$$n = 2\frac{1}{2},$$

$$\therefore S_{diag. 6} = \frac{5}{2} P \sec \theta.$$

Stresses on the Flanges.—The stresses on each bay of the flanges is obtained by adding together the stresses produced on such bay by each weight when it acts separately. It has been shown that, with a single weight, P , acting on the extremity of the cantilever, the increment of stress on each successive bay of a flange $= 2 P \tan \theta$. When all the weights act on the girder simultaneously, the increment of stress on each successive bay is

not a constant quantity, the increment increasing with each successive bay.

Let n = number of the bay measured along its flanges from the free end of the cantilever.

Then, for the bottom or *loaded* flange, the stress on a bay is represented by

$$S_{\text{nth bay}} = \left\{ n(n-1) + \frac{1}{2} \right\} P \tan \theta ;$$

and, for the top or *unloaded* flange, by

$$S_{\text{nth bay}} = n^2 P \tan \theta.$$

Applying these formulæ to the example under consideration, we get—

TABLE XXXVII.

Flanges,	A	B	C	D	E	F	G	H
Stress,	$+\frac{P}{2} \tan \theta$	$+\frac{5}{2} P \tan \theta$	$+\frac{18}{2} P \tan \theta$	$+\frac{25}{2} P \tan \theta$	$-P \tan \theta$	$-4 P \tan \theta$	$-9 P \tan \theta$	$-16 P \tan \theta$

These stresses on the flanges may be verified by the principle of moments, thus—

Let a = length of a bay,

d = depth of girder,

$$\tan \theta = \frac{a}{2d}$$

To find the stress on the bay F, for example, take moments about the point of intersection of diagonals 4 and 5, and we get—

$$S_F \times d = \frac{P}{2} \times 2a + Pa = 2Pa,$$

$$\text{or } S_F = 4P \frac{a}{2d} = 4P \tan \theta.$$

In the same way the stresses on the other bays may be verified.

From the foregoing description, the student will have no difficulty in determining the stresses on a cantilever, when loaded on the top instead of the bottom flange.

Example 7.—The projecting arm of a swing bridge is sup-

ported by two Warren cantilever girders 40 feet long and 8·66 feet deep of the form shown in fig. 113. The dead load of the bridge = $1\frac{1}{4}$ tons per foot and the live load = $\frac{3}{4}$ ton per foot; the load being applied by cross girders resting on the top apices of the main girders. Determine the stresses on the various parts of the cantilever.

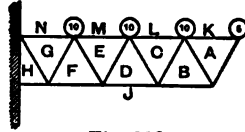

Fig. 113.

Dead load on projecting arm = $40 \times 1\frac{1}{4} = 50$ tons,
 Live „ „ „ = $40 \times \frac{3}{4} = 30$ tons.

The total distributed load, therefore, on bridge = 80 tons.
 This is equivalent to a load of 40 tons on each cantilever, or 10 tons on each bay.
 Distributing this on the apices we get a load of 10 tons on each apex, except the end one, which has a load of 5 tons.

$$\theta = 30^\circ. \quad \sec \theta = 1.154, \quad \tan \theta = 0.577, \quad P = 10 \text{ tons.}$$

The stresses on the diagonals and flanges may be found from the tables last given, remembering that the load is applied at the top instead of the bottom flange.

TABLE XXXVIII.

Diagonals,	A J	A B	B C	C D	D E	E F	F G	G H
	Tons.	Tons.	Tons.	Tons.	Tons.	Tons.	Tons.	Tons.
Stresses,	+5.77	-5.77	+17.31	-17.31	+28.85	-28.85	+40.40	-40.4
Flanges,	A K	C L	E M	G N	B J	D J	F J	H J
	Tons.	Tons.	Tons.	Tons.	Tons.	Tons.	Tons.	Tons.
Stresses,	-2.88	-14.40	-37.44	-72.0	+5.77	+23.06	+61.98	+92.32

The flange stresses may also be found by the method of moments. Thus, to find the stress on the bay of the bottom flange next the abutment, we get, by taking moments round the point of intersection of the diagonal next the abutment with the top flange—

$$S_{HJ} \times 8.66 = 10 \{10 + 20 + 30\} + 5 \times 40 = 800,$$

or $S_{HJ} = 92.31$ tons.

187. Warren Girders with Vertical Bracings.—Fig. 114 is an example of a Warren girder with vertical bracings arranged for a load resting on the bottom flange. When the cross girders of

a bridge not only rest on the apices of the girder but also on the centres of the bays, bending moments are produced in the latter, which, if possible, ought to be avoided, especially if the bays be long; the vertical braces are introduced with the object of preventing this bending action. When the load is carried on the bottom flange all the verticals are in tension, and the stress on each will be equal to the load transmitted by the cross-girder. When the girder shown in fig. 114 is loaded uniformly on the bottom flange, the effect is precisely the same as if all the apices in both flanges were loaded, and the method of calculating the stresses is similar to that already explained.

Example 8.—A railway bridge carrying a double line is 90 feet span, and is supported by two main Warren girders of the type

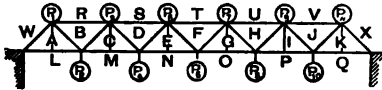

Fig. 114.

shown in fig. 114; the bottom booms of the girders are divided into six bays of 15 feet each, and the depth of the girders is 7 feet 6 inches. The cross-girders are supported on the apices and the centres of the bays. If the dead load of the bridge, including the permanent way, be equal to $1\frac{1}{4}$ ton per foot, and the live load for each pair of rails be $1\frac{3}{8}$ ton per foot, find the stresses on, and draw a stress diagram of the main girders when the bridge is fully loaded.

$$\text{Dead load on bridge} = 90 \times 1\frac{1}{4} = 112.5 \text{ tons,}$$

$$\text{Live load on bridge} = 90 \times 2\frac{1}{4} = 247.5 \text{ tons.}$$

$$\text{Total load on both main girders} = 360 \text{ tons,}$$

$$\text{Total load on one main girder} = 180 \text{ tons.}$$

This is equivalent to 11 loads of 15 tons each resting on the bottom flange of each

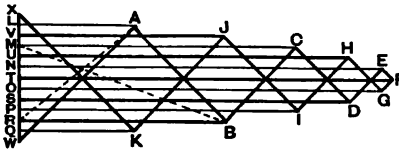

Fig. 115.

girder; and as the vertical members transmit the loads on the centres of the bays to the top apices, the effect on the girder will be the same as if 5 loads of 15 tons each rested on the bottom flange, and 6 loads of the same amount rested on the top flange, all the loads being applied at the apices.

The supporting forces at each abutment = 82.5 tons.

$$\theta = 45^\circ, \quad \tan \theta = 1, \quad \sec \theta = 1.414.$$

The girder being loaded symmetrically, the stresses on the right half are precisely the same as those on the left.

Flanges.—The stresses on the flanges are most readily determined by the principle of moments.

$$S_{AL} = - 82.5 \text{ tons,}$$

$$S_{BR} = + 150.0 \text{ ,,}$$

$$S_{CM} = - 202.5 \text{ ,,}$$

$$S_{DS} = + 240.0 \text{ ,,}$$

$$S_{MN} = - 262.5 \text{ ,,}$$

$$S_{FT} = + 270.0 \text{ ,,}$$

Diagonals.—The stresses on the diagonals may be found by calculating the stress on each, for each load taken in succession, and taking the algebraic sum.

In order to distinguish the different loads, let them be designated by $P_1, P_2, P_3, \&c.$ The following table gives the stress on each diagonal produced by each load, and also the total stress when all the loads act simultaneously:—

TABLE XXXIX.—STRESSES ON DIAGONALS.

Diagonals.	P_1	P_2	P_3	P_4	P_5	P_6	P_7	P_8	P_9	P_{10}	B_{11}	Total Stress.
A W	+19.44	+17.67	+16.00	+14.12	+12.37	+10.60	+8.83	+7.07	+5.30	+3.53	+1.76	+116.6
AB	+ 1.76	-17.67	-16.00	-14.12	-12.37	-10.60	-8.83	-7.07	-5.30	-3.53	-1.76	- 95.4
BC	- 1.76	- 3.53	+16.00	+14.12	+12.37	+10.60	+8.83	+7.07	+5.30	+3.53	+1.76	+ 74.2
CD	+ 1.76	+ 3.53	+ 5.30	-14.12	-12.37	-10.60	-8.83	-7.07	-5.30	-3.53	-1.76	- 63.0
DE	- 1.76	- 3.53	- 5.30	+ 7.07	+12.37	+10.60	+8.83	+7.07	+5.30	+3.53	+1.76	+ 31.8
EF	+ 1.76	+ 3.53	+ 5.30	+ 7.07	+ 8.83	-10.60	-8.83	-7.07	-5.30	-3.53	-1.76	- 10.6

It will be seen from the table that the stresses on the diagonals vary from 10.6 tons at the centre to 116.6 tons at the ends of the girder; and that the increment of stress for each diagonal as we approach the ends is 21.2 tons, or twice the stress on the centre diagonals. It will also be observed that the stress on

any diagonal is equal to the load between it and the centre of the girder multiplied by the secant of the angle of inclination which the diagonal makes with a vertical line. For example, the load between the diagonal BC and the centre of the girder is 52.5 tons, so that

$$S_{BC} = 52.5 \times \sec 45^\circ = 74.2 \text{ tons,}$$

which agrees with that given in the table.

Fig. 115, which is drawn to scale, represents the stress diagram of the girder.

CHAPTER XIV.

BRACED GIRDERS—*continued.*

LATTICE GIRDERS—LINVILLE TRUSSES.

188. Definition.—The term "lattice girder," in its most general sense, is applied to all braced girders, that is, girders whose webs are composed of inclined or vertical braces or lattices. In a more restricted sense, however, a lattice girder is usually understood to be one whose web is composed of two or more systems of the Warren type. Fig. 116 is a lattice girder of a *double*

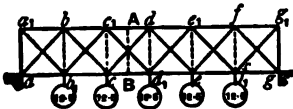

Fig. 116.



Fig. 117.

system of triangulation. One system being $abcdefg$ and the other $a_1b_1c_1d_1e_1f_1g_1$. Each of these forms a complete Warren girder in itself. The two end vertical members, aa_1 and gg_1 , are called the end posts or pillars, and they serve to transmit the upward reactions of the abutments equally to the two systems, one-half of the abutment reaction being directly transmitted through the vertical pillar aa_1 , while the other half is resolved along the diagonal ab .

189. Stresses on Lattice Girders.—From what has been said on the subject of Warren girders, there will be little difficulty

in determining the stresses on girders of this lattice type, it being only necessary to consider each system of triangulation separately.

When a lattice girder of a given span and depth is loaded uniformly, the stresses on the braces are inversely proportional to the number of systems of triangles in the web. For example, the stresses in the braces of a girder like that shown in fig. 116 are approximately *one-half* of those in the corresponding braces in a girder of a single system, or Warren girder; while in a girder of a quadruple system, like that shown in fig. 117, they are approximately *one-fourth* of those in a Warren girder.

Lattice girders usually have vertical members situated at certain intervals along the girder. These are introduced with the object of distributing the load between the top and bottom flanges, and also of giving lateral stiffness to the girder, and need not, as a rule, be considered in calculating the stresses.

The flange stresses on lattice girders may be determined by the method of moments, but the calculation of the stresses by this plan is not so simple as in the case of girders with a single system of triangulation. For example, let us consider how to determine the stress on the bay $c_1 d$ (fig. 116). By drawing a vertical line, A B, through this bay, it will be seen that the portion of the girder to the left of the line, A B, is held in equilibrium—

- (1) By the reaction of the left abutment;
- (2) The vertical loads acting on $a_1 A B a_1$;
- (3) The stresses in the bays $c_1 d$ and $c d_1$; and
- (4) The stresses in the diagonals $c d$ and $c_1 d_1$.

And in order to determine the stresses in the flanges we must first know the stresses in the diagonals. If, as is frequently the case, the stresses in the pair of diagonals be equal to each other, then the moments of these two forces neutralise, so that they need not be considered, in which case the determination of the flange stresses is a simple matter, at least in girders of this type.

In dealing with lattice girders, no matter how complicated the system of triangulation, the readiest method of determining the stresses is by drawing a stress diagram for each system and adding the results together.

Example 1.—A bridge 60 feet span is supported by two lattice girders of a double system of triangulation. The girders are 10 feet deep, and each flange is divided into six equal bays of

10 feet. If the dead load on the bridge be equal to $1\frac{1}{2}$ tons per foot, and the live load to 1 ton per foot, determine the stresses on the girders when the bridge is fully loaded.

Dead load on bridge	=	$60 \times 1\frac{1}{2}$	=	90 tons.
Live	„	„	=	$60 \times 1 = 60$ „
—				
Total	„	„	=	150 „
Total load on each girder			=	75 „

This is equivalent to loads of 12.5 tons resting on each apex on the bottom flange (see fig. 116).

The girder may be supposed to consist of two Warren girders, namely, $a b c d e f g$ and $a_1 b_1 c_1 d_1 e_1 f_1 g_1$, the first being loaded with two weights of 12.5 tons resting at the points c and e , and the second being loaded with three weights of 12.5 tons resting at b_1 , d_1 and f_1 .

Considering each one separately we get for the first system—

$$\begin{aligned} S_{a,b} &= +12.5 \sec \theta = +17.67 \text{ tons} = S_{e,f} \\ S_{b,c} &= -12.5 \sec \theta = -17.67 \text{ tons} = S_{f,g} \\ S_{c,d} &= S_{d,e} = \text{zero,} \\ S_{e,f} &= -12.5 \text{ tons} = S_{e,g} \\ S_{b,d} &= +25 \text{ tons} = S_{a,f} \\ S_{c,e} &= -25 \text{ tons;} \end{aligned}$$

and for the second system—

$$\begin{aligned} S_{a_1,b_1} &= -18.75 \sec \theta = -26.51 \text{ tons} = S_{f_1,g_1} \\ S_{b_1,c_1} &= +6.25 \sec \theta = +8.83 \text{ tons} = S_{a_1,f_1} \\ S_{c_1,d_1} &= -6.25 \sec \theta = -8.83 \text{ tons} = S_{a_1,e_1} \\ S_{a_1,c_1} &= +18.75 \text{ tons} = S_{a_1,f_1} \\ S_{b_1,d_1} &= -25 \text{ tons} = S_{a_1,f_1} \\ S_{c_1,e_1} &= +31.25 \text{ tons.} \end{aligned}$$

Having thus determined the flange stresses for each system separately, we must add them together where the stresses, so to speak, overlap each other. Thus, for example, as the stress on the bay $b d$ is 25 tons, and that on $c_1 e_1$ is 31.25 tons, the total stress on the bay $c_1 d$ (which is common to both) must be equal to the sum of these stresses, viz., 56.25 tons.

Table XL. gives the complete stresses on the girder.

TABLE XL.—LATTICE GIRDERS WITHOUT VERTICALS.

Diagonals,	$a b$	$a_1 b_1$	$b c$	$b_1 c_1$	$c d$	$c_1 d_1$	$d e$	$d_1 e_1$	$e f$	$e_1 f_1$	$f g$	$f_1 g_1$
Stresses,	+17.67	-26.51	-17.67	+8.83	0	-8.83	0	-8.83	-17.67	+8.83	+17.67	-26.51
Bay's,	$a b_1$	$a_1 b$	$b_1 c$	$b c_1$	$c d_1$	$c_1 d$	$d_1 e$	$d e_1$	$e f_1$	$e_1 f$	$f_1 g$	$f g_1$
Stresses,	-12.5	+18.75	-37.5	+43.75	-50.0	+56.25	-50.0	+56.25	-37.5	+43.75	-12.5	+18.75

TABLE XLI.—LATTICE GIRDERS WITH VERTICALS.

Diagonals,	$a b$	$a_1 b_1$	$b c$	$b_1 c_1$	$c d$	$c_1 d_1$	$d e$	$d_1 e_1$	$e f$	$e_1 f_1$	$f g$	$f_1 g_1$
Stresses,	+22.09	-22.09	-13.25	+13.25	+4.41	-4.41	+4.41	-4.41	-13.25	+13.25	+22.09	-22.09
Flanges,	$a b_1$	$a_1 b$	$b_1 c$	$b c_1$	$c d_1$	$c_1 d$	$d_1 e$	$d e_1$	$e f_1$	$e_1 f$	$f_1 g$	$f g_1$
Stresses,	-15.625	+15.625	-40.625	+40.625	-53.125	+53.125	-53.125	+53.125	-40.625	+40.625	-15.625	+15.625

It will be noticed that in this example the stresses on the intersecting diagonals are not equal, also the stresses on the top and bottom bays opposite each other are unequal. This inequality will be removed if a number of verticals be introduced into the girder. The function of these verticals is merely to distribute half the loads resting on the bottom apices to the top apices, and also to give external stability to the girder. With this arrangement the girder may be considered as loaded with weights of 6.25 tons resting on both the top and bottom apices, and the only direct stress in the verticals will be a tensile one equal to 6.25 tons. Of course this is the theoretical view of the case, and the assumption is a convenient one. In practice it is difficult to say how much direct stress really passes along the verticals. This question is, however, practically unimportant, and does not materially affect the general result. We may therefore assume that each of the Warren trusses, into which the girder may be separated, is similarly loaded, there being 5 loads of 6.25 tons resting on each. The stress on each of the end pillars will be 15.625 tons, and Table XLI. gives the stresses on the lattices and flanges.

The advantages derived from the introduction of the vertical members is apparent by comparing Tables XL. and XLI. In the first the maximum stress on the lattices is 26.51 tons, as against 22.09 tons in the second; while the maximum stress on the flanges is 56.25 tons, as against 53.125 tons.

GIRDERS WITH INCLINED AND VERTICAL BRACING.

190. Linville Trusses.—The form of truss shown in fig. 118 is

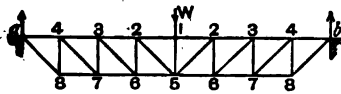

Fig. 118.

generally known as the Linville truss from the name of its inventor. It is a very useful and economical form of girder, and is largely used both in this country and in America, either in the single system of

triangulation (as shown in the figure), or in the double, triple, or quadruple systems.

When this truss is loaded either on the top or bottom flange, the vertical braces will be in compression and the inclined ones in tension. In this respect it has an advantage over the Warren girder, as it is always best to have the long braces in tension.

If the truss be inverted the nature of the stresses on the

bracings will be reversed, the inclined brace being in compression and the vertical ones in tension. It is unnecessary to remark that a girder of this type is not so economical.

191. **Linville Truss Loaded with a Single Weight at the Centre.**—Let the girder shown in fig. 118 be loaded with a single weight, W , resting at the centre of the top flange.

Let θ = angle which inclined braces make, with the vertical.

$$\text{Reaction at each abutment} = \frac{W}{2}.$$

From the explanations already given, it is evident that there is a compressive stress equal to $\frac{W}{2}$ on all the vertical members except the central one which is exposed to a compressive stress equal to W . It is also apparent that the stresses on the inclined bars are all tensile and equal to each other, and that this stress = $\frac{W}{2} \sec \theta$.

Flanges.—By resolving the three forces acting at the point a , we get—

$$S_{.4} = + \frac{W}{2} \tan \theta.$$

The increment of stress at each successive apex is $\frac{W}{2} \tan \theta$.

We, therefore, have the following stresses on the bays :—

TABLE XLII.

Flanges,	a 4	87	43	76	32	65	21
Stresses,	$+\frac{W}{2} \tan \theta$	$-\frac{W}{2} \tan \theta$	$+\frac{W}{2} \tan \theta$	$-\frac{W}{2} \tan \theta$	$+\frac{3}{2} W \tan \theta$	$-\frac{5}{2} W \tan \theta$	$+\frac{7}{2} W \tan \theta$

192. **Truss Loaded with a Single Weight at any Point.**—If the weight rest at the apex 2_1 , instead of at the centre, the form of the girder will be as shown in fig. 119.

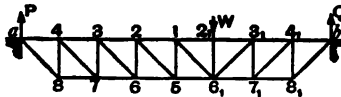

Fig. 119.

The stresses on the vertical braces to the left of W = $+ P$.

” ” ” right ” = $+ Q$.

” inclined ” left ” = $- P \sec \theta$.

” ” right ” = $- Q \sec \theta$.

The stress on the vertical brace at W = $+ W$.

The stresses on the flanges are given in Table XLIII.

TABLE XLIII.

Top Flange,	$\alpha 4$	43	32	21	12 ₁	2 ₁ 3 ₁	3 ₁ 4 ₁	4 ₁ b
Stresses,	$+P \tan \theta$	$+2P \tan \theta$	$+3P \tan \theta$	$+4P \tan \theta$	$+5P \tan \theta$	$+3Q \tan \theta$	$+2Q \tan \theta$	$+Q \tan \theta$
Bottom Flange,	87	76	65	56 ₁	6 ₁ 7 ₁	7 ₁ 8 ₁		
Stresses,	$-P \tan \theta$	$-2P \tan \theta$	$-3P \tan \theta$	$-4P \tan \theta$	$-2Q \tan \theta$	$-Q \tan \theta$		

Example 2.—A Linville truss (fig. 120) of six equal divisions is 60 feet span and 10 feet deep, and has a load of 8 tons resting on the apex 10 feet to the left of the centre. Determine the stresses on the truss and draw a stress diagram.

$$\theta = 45^\circ, \quad \tan \theta = 1, \quad \sec \theta = 1.414.$$

Reaction of left abutment $P = 5.33$ tons.

„ right „ $Q = 2.66$ tons.

The stresses are given in Table XLIV.

The stress diagram is shown in fig. 121, which is drawn to scale.

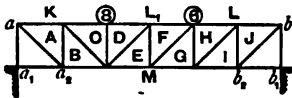

Fig. 120.

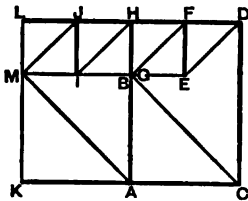

Fig. 121.

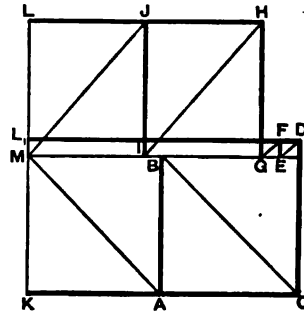

Fig. 122.

Example 3.—If in the last example an additional load of 6 tons rest on the apex 10 feet to the right of the centre, determine the solution.

Fig. 122, which is drawn to scale, represents the stress diagram. By scaling we get the results given in Table XLV.

TABLE XLIV.

Verticals, . . .	AB	CD	EF	GH	IJ				
Stresses, . . .	+5.33	+8.0	+2.66	+2.66	+2.66				
Diagonals, . . .	MA	BC	DE	FG	HI	JM			
Stresses, . . .	-7.54	-7.54	-3.77	-3.77	-3.77	-3.77			
Flanges, . . .	AK	CK	DL	FL	HL	JL	BM	EM	IM
Stresses, . . .	+5.33	+10.66	+10.66	+8.0	+5.33	+2.66	-5.33	-8.0	-5.33

TABLE XLV.

Verticals, . . .	AB	CD	EF	GH	IJ				
Stresses, . . .	+7.33	+8.0	+0.66	+6.66	+6.66				
Diagonals, . . .	MA	BC	DE	FG	HI	JM			
Stresses, . . .	-10.37	-10.37	-0.94	-0.94	-9.43	-9.43			
Flanges, . . .	AK	CK	DL ₁	FL ₁	HL	JL	BM	EM	IM
Stresses, . . .	+7.33	+14.66	+14.66	+14.0	+13.33	+6.66	-7.33	-14.0	-13.33

193. **Linville Truss Weighted with an Evenly Distributed Load.**
Case I.—First suppose the number of bays to be even. Fig. 123 represents a Linville girder divided into 8 equal bays.

Let l = span of girder,
 a = length of each bay,
 d = depth of truss,
 θ = angle which the inclined braces make with the vertical,
 P = external load on each panel.

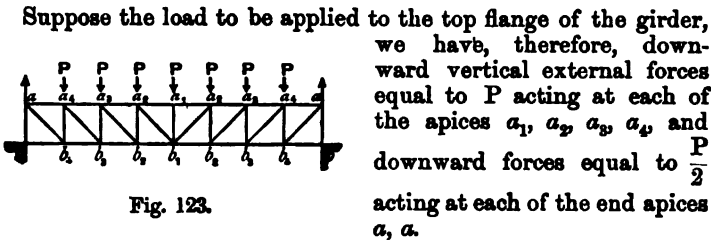

Fig. 123.

The vertical reactions of the abutments at b and $b_8 = 4P$; but as $\frac{P}{2}$ acts downwards at a and a_8 , the net upward reaction at each of these points will be $\frac{7P}{2}$.

Vertical Posts.—By reasoning in a manner similar to that already used, we get the compressive stress on the centre post $a_1 b_1 = P$. One-half of this stress is communicated by means of the inclined braces $b_1 a_2, b_1 a_2$ to each of the posts $a_2 b_2$ and $a_2 b_2$, and these posts have in addition the stresses P, P which are communicated directly to them by the loads on the apices at a_2, a_2 , so that the total compressive stress on each of these posts = $\frac{3}{2}P$. In the same way it may be shown that the

total compressive stress on each of the verticals $a_3 b_3 = \frac{5}{2}P$,

” ” ” $a_4 b_4 = \frac{7}{2}P$,

” ” ” $a b = 4P$.

Diagonal Braces.—The stress on each of the diagonal braces arising from the central weight $P = -\frac{P}{2} \sec \theta$.

The stresses on each of the diagonals $b_2 a_3$, $b_3 a_4$ and $b_4 a$, arising from the weights resting at each of the apices a_2 and $a_3 = -P \sec \theta$. These weights do not affect the central diagonals $b_1 a_2$. The stresses on each of the diagonals $b_2 a_3$, $b_3 a_4$, and $b_4 a$ arising from the three central weights will therefore be equal to $-3 \frac{P}{2} \sec \theta$.

In the same way it may be shown that the weights at each of the points a_2 and a_3 add an increment of stress to the diagonals $b_3 a_4$ and $b_4 a$, while they do not affect the diagonals between these points and the centre of the girder.

Again, the weights at the apices a_1 and a_4 affect only the two end diagonals, giving to them an additional stress = $P \sec \theta$. By adding together all the stresses produced on a diagonal by the different weights we get the total stress on this diagonal.

Flanges. — The stresses on the flanges may be found in a similar manner to that explained for Warren girders, so that it is not necessary to repeat the process. The maximum stress occurs in the two central bays of the top flange and equals $8 P \tan \theta$. The minimum stress occurs at the two end bays, $b b_4$, of the bottom flange, and is equal to zero.

Theoretically, the truss is complete without these bays, and also without the two end vertical posts $a b$; but practical considerations are usually in favour of their retention.

The stresses on the girder are given in Table XLVI. The load being symmetrical, the stresses on the two halves of the girder are the same.

If the loads rest on the bottom apices the stresses on the different members of the girders will be exactly the same, except those on the vertical posts, the stresses in each of these being diminished by the amount $\frac{P}{2}$; there will be no stress on the central post, which consequently will not be required.

In the general case where n = number of bays in the truss, the reaction at each abutment = $\frac{n-1}{2} P$.

The stresses on the vertical posts, reckoning from the centre towards the ends, with girders loaded on the top, are—

$$P, \quad \frac{3}{2} P, \quad \frac{5}{2} P, \quad \frac{7}{2} P, \quad \dots \quad \frac{n}{2} P.$$

The stresses on the diagonal braces, reckoning the same way, are :—

TABLE XLVI.

Vertical Posts,	$a b$	$a_4 b_4$	$a_2 b_3$	$a_1 b_1$			
Stresses,	$+4 P$	$+\frac{7}{2} P$	$+\frac{5}{2} P$	$+\frac{3}{2} P$	$+ P$		
Diagonal Braces,	$a b_4$	$a_4 b_3$	$a_3 b_3$	$a_3 b_1$			
Stresses,	$-\frac{7}{2} P \sec \theta$	$-\frac{5}{2} P \sec \theta$	$-\frac{3}{2} P \sec \theta$	$-\frac{1}{2} P \sec \theta$			
Flanges,	$a a_4$	$a_4 a_3$	$a_3 a_3$	$a_3 a_1$	$b b_4$	$b_4 b_3$	$b_3 b_1$
Stresses,	$+\frac{7}{2} P \tan \theta$	$+6 P \tan \theta$	$+\frac{15}{2} P \tan \theta$	$+8 P \tan \theta$	zero	$-\frac{7}{2} P \tan \theta$	$-\frac{15}{2} P \tan \theta$

TABLE XLVII.

Vertical Posts,	$a b$	$a_4 b_4$	$a_3 b_3$	$a_1 b_1$			
Stresses,	$+\frac{9}{2} P$	$+4 P$	$+3 P$	$+ P$			
Diagonal Braces,	$a b_4$	$a_4 b_3$	$a_3 b_3$	$a_1 b_1$			
Stresses,	$-\frac{4}{2} P \sec \theta$	$-3 P \sec \theta$	$-2 P \sec \theta$	zero			
Flanges,	$a a_4$	$a_4 a_3$	$a_3 a_3$	$a_1 a_1$	$b b_4$	$b_4 b_3$	$b_3 b_1$
Stresses,	$+4 P \tan \theta$	$+7 P \tan \theta$	$+9 P \tan \theta$	$+10 P \tan \theta$	zero	$-4 P \tan \theta$	$-10 P \tan \theta$

$$\begin{aligned} \frac{1}{2} P \sec \theta, \quad \frac{3}{2} P \sec \theta, \quad \frac{5}{2} P \sec \theta, \quad \frac{7}{2} P \sec \theta, \\ \dots \quad \frac{n-1}{2} P \sec \theta. \end{aligned}$$

The stresses on the flanges, reckoning from the abutments towards the centre, and neglecting the first bay in the bottom flange on which there is no stress, are :—

$$\begin{aligned} \frac{n-1}{2} P \tan \theta, \quad (n-2) P \tan \theta, \quad \frac{3(n-3)}{2} P \tan \theta, \\ 2(n-4) P \tan \theta, \quad \dots \quad \frac{n^2 P}{8} \tan \theta. \end{aligned}$$

These expressions for the flange stresses are found by taking moments about the apices. For example, to find the stress in the third bay in the top flange, we get—

$$\begin{aligned} S \times d = \frac{n-1}{2} P \times 3a - P \times 3a = \frac{3(n-3)}{2} P a, \\ S = \frac{3(n-3)}{2} P \times \frac{a}{d} = \frac{3(n-3)}{2} P \tan \theta. \end{aligned}$$

If the girder contain 16 equal bays, the stress in the centre bay of the top flange = $\frac{n^2 P}{8} \tan \theta = 32 P \tan \theta$.

194. Case II.—If the girder be divided into an odd number of bays, as shown in fig. 124, both its construction and the stresses on it will be slightly modified. Theoretically, there is no neces-

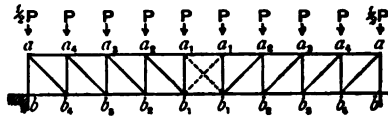

Fig. 124.

sity for any diagonal braces in the centre bay of the girder with a uniform load. It is customary, however, to insert two, as shown by the dotted lines $a_5 b$ and $a_6 b_1$.

TABLE XLVIII.

Verticals,	$a_1 b_1$	$a_2 b_2$	$a_3 b_3$	$a_4 b_4$	$a_5 b_5$	$a_6 b_6$	$a_7 b_7$	$a_8 b_8$	$a_9 b_9$	$a b$
Stresses,	zero	zero	$+\frac{1}{2} P$	$+ P$	$+\frac{3}{2} P$	$+2 P$	$+\frac{5}{2} P$	$+3 P$	$+\frac{7}{2} P$	$+\frac{17}{2} P$
Diagonals,	$a_2 b_1$	$a_4 b_2$	$a_6 b_3$	$a_8 b_4$	$a_7 b_5$	$a_9 b_6$	$a_9 b_7$	$a b_8$	$a b_9$	
Stresses,	$-\frac{1}{2} P \sec \theta$	$- P \sec \theta$	$-\frac{3}{2} P \sec \theta$	$-2 P \sec \theta$	$-\frac{5}{2} P \sec \theta$	$3 P \sec \theta$	$-\frac{7}{2} P \sec \theta$	$-4 P \sec \theta$	$-\frac{9}{2} P \sec \theta$	$-\frac{9}{2} P \sec \phi^*$
Top Flange, }	$a a_9$	$a_9 a_6$	$a_6 a_7$	$a_7 a_8$	$a_8 a_5$	$a_5 a_4$	$a_4 a_3$	$a_3 a_2$	$a_2 a_1$	
Stresses,	$\frac{25}{4} P \tan \theta$	$+\frac{39}{4} P \tan \theta$	$+\frac{51}{4} P \tan \theta$	$+\frac{61}{4} P \tan \theta$	$+\frac{69}{4} P \tan \theta$	$+\frac{75}{4} P \tan \theta$	$+\frac{79}{4} P \tan \theta$	$+\frac{81}{4} P \tan \theta$	$+\frac{81}{4} P \tan \theta$	
Bottom Flange, }	$b b_9$	$b_9 b_8$	$b_8 b_7$	$b_7 b_6$	$b_6 b_5$	$b_5 b_4$	$b_4 b_3$	$b_3 b_2$	$b_2 b_1$	
Stresses,	zero	$-\frac{9}{4} P \tan \theta$	$-\frac{25}{4} P \tan \theta$	$-\frac{39}{4} P \tan \theta$	$-\frac{51}{4} P \tan \theta$	$-\frac{61}{4} P \tan \theta$	$-\frac{69}{4} P \tan \theta$	$-\frac{75}{4} P \tan \theta$	$-\frac{79}{4} P \tan \theta$	

* ϕ = angle which $a b_9$ makes with the vertical.

The stresses on each of the central verticals $a_1 b_1$ and $a_2 b_2$ will be equal to P , and the increment of stress on each of the others taken in succession towards the abutments will be equal to P .

Table XLVII. gives the stresses for the girder.

If the load rest on the bottom flange the stress in each of the vertical members, except those over the abutments, is diminished by the amount P , while the stress in each of the end verticals is diminished by $\frac{1}{2} P$.

Fig. 125 represents a form of Linville truss which is commonly employed for bridges of large span. The inclined braces, instead of joining the top of one vertical stay to the foot of the next, is carried to the foot of the next but one. This converts the girder into two simple Linville trusses, the number of the diagonal and vertical braces being doubled, and the stresses on them reduced to one-half of what they would be if only a single system were employed.

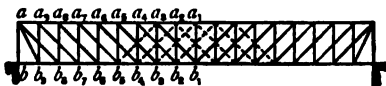

Fig. 125.

If this girder be loaded uniformly along the bottom flange by weights equal to P resting at each apex, Table XLVIII. will give the stresses on the various members of the truss.

With a uniform dead load there is no stress on the diagonal braces shown by dotted lines at the centre of the girder; however, with a rolling load they are subject to stresses, and are consequently introduced.

Example 3.—A bridge, 100 feet span, is carried by a pair of Linville trusses, each of which is 10 feet deep and divided into 10 equal bays. If the weight of the bridge fully loaded be equal to 2 tons per foot equally distributed, determine the stresses; the load resting on the top flange.

Total load on the bridge = $100 \times 2 = 200$ tons,

“ “ each girder = $100 \times 1 = 100$ tons.

This is equivalent to a load of 10 tons for each panel, or 9 weights of 10 tons each resting on the bottom apices, and 2 weights of 5 tons each resting directly over the abutments.

The net upward reaction at each abutment = 45 tons.

The inclination of the diagonal braces to the vertical = 45° .

$$\sec 45^\circ = 1.414; \quad \tan 45^\circ = 1.$$

The stresses are given in Table XLIX.

TABLE XLIX.

Vertical Posts,	A B	C D	E F	G H	I I ₁
Stresses, . . .	+45·0	+35·0	+25·0	+15·0	+10·0
Diagonal Braces,	A O	B C	D E	F G	H I
Stresses, . . .	-63·63	-49·49	-35·35	-21·21	-7·07
Top Flange, .	A J	C K	E L	G M	I N
Stresses, . . .	+45·0	+80·0	+105·0	+120·0	+125·0
Bottom Flange,	B O	D O	F O	H O	
Stresses, . . .	-45·0	-80·0	-105·0	-120·0	

Example 4.—A railway bridge, 80 feet span, is carried by a pair of Linville girders 8 feet deep and divided into 10 equal divisions. A uniform dead load of 80 tons is distributed over

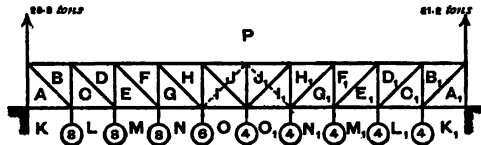

Fig. 126.

the platform which rests on the bottom booms of the girders. A rolling load consisting of a train of waggons weighing 1 ton per foot comes on the bridge from the left, to a distance of 32 feet, thereby covering four bays of the girder. Draw the stress diagram—

$$\begin{aligned} \text{Dead load on bridge} &= 80 \text{ tons,} \\ \text{,, one girder} &= 40 \text{ tons.} \end{aligned}$$

This is equivalent to a weight of 4 tons on each panel.

$$\begin{aligned} \text{Live load on bridge} &= 32 \times 1 = 32 \text{ tons,} \\ \text{,, each girder} &= 16 \text{ tons.} \end{aligned}$$

This is equivalent to 4 tons on each of the four panels to the

left of the girder, so that the total load on each of the four panels to the left = 8 tons, and that on each of the other six panels = 4 tons.

This distribution of load is equivalent to three weights of 8 tons resting at the feet of the three pillars next the left abutment — excluding that directly over it — one weight of 6 tons resting at the foot of the fourth pillar, and five weights of 4 tons resting at the feet of the other pillars.

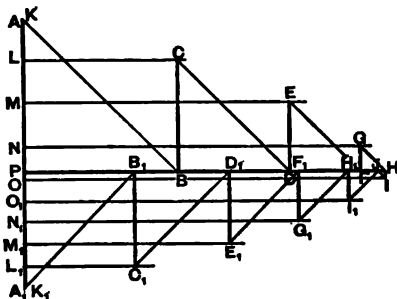

Fig. 127.

The net reaction of the left abutment from the dead load = 18 tons and from the live load = 10·8 tons, so that the total vertical reaction of the left abutment = 28·8 tons.

The reaction at the right abutment is 18 tons for the dead load and 3·2 tons for the live load, or a total of 21·2 tons.

Stress Diagram.—Fig. 126 represents the girder, and fig. 127 the stress diagram. To construct the latter take the vertical line $A A_1 = 50$ tons, the total load resting on the bottom flange, excluding the portions carried directly by the abutments. Set off $A P = 28·8$ tons, the reaction of the left abutment; and $A_1 P = 21·2$ tons, the reaction of the right abutment. Set off $A L = L M = M N = 8$ tons, $N O = 6$ tons, and $O O_1 = O_1 N_1 = N_1 M_1 = M_1 L_1 = L_1 A_1 = 4$ tons.

The diagram is constructed in the usual manner, and its accuracy is verified by its being found to close, the last line drawn, viz., $B_1 A_1$, parallel to the last diagonal, $B_1 A_1$ coming exactly to the point A_1 .

By scaling, the following values (see Table L.) will be found for the stresses on the different members of the girder. The correctness of the results may be checked analytically in the way already explained.

It will be noticed that the effect of the rolling load coming on the girder from the left abutment is to put a compressive stress on the diagonal brace $I J$, and a tensile stress on the vertical pillar $H I$. All the other diagonals and verticals being exposed to tensile and compressive stresses respectively, except the vertical $J J_1$, which has no stress.

If the rolling load come on the bridge from the opposite

direction, there will be a compressive stress of 1·7 tons on diagonal $I_1 J_1$, and a tensile stress of 1·2 tons on the vertical $I_1 H_1$. As the diagonal braces of girders of this description are usually made of flat bars, which are not adapted to transmit a compressive stress, it will be necessary to use counterbraces at the centre of the girder, as represented by the dotted lines. These latter relieve the diagonal braces at the centre of any compressive stress by themselves transmitting tensile stresses.

If the rolling load compared to the dead load be relatively larger than that given, as would be the case with a double line of railway, other diagonal braces besides the two centre ones may be subjected to compressive stress, and consequently extra counterbracing will be necessary.

Example 5.—If, in the last example, the rolling load coming on the bridge consist of a single weight of 30 tons, traversing it centrally from one end to the other, determine the maximum stresses on each member of the girders in its progress.

Suppose the load to traverse the bridge from left to right. The maximum stresses on the bays P B and C L will occur when the load of 15 tons (half of 30 tons) rests on the first apex of the bottom flange, reckoning from the left abutment.

The maximum stresses on the diagonal A B and the vertical B C will also occur when the load occupies this position. Similarly, when the load rests on the second apex, the maximum stresses will occur on the members P D, E M, C D, and D E; and so on.

Table LI. gives—

1. The stress on each member from the dead load.
2. The maximum stresses for the rolling load.
3. The total maximum stresses arising from the dead and live loads combined.

This forms a most excellent example of the effect of rolling loads on lattice girders, and a careful study of it will well repay the attention of the student.

It will be noticed that with both loads it will only be necessary to counterbrace the two centre bays. If the dead load, however, be very small compared with the rolling load, it would be necessary to counterbrace all the bays, with the exception of the two end ones, so that the girder would be practically a double Warren girder. The Linville truss is, therefore, unsuitable for small spans carrying a heavy rolling load. In large railway bridges, however, where the dead load forms a large proportion

of the total load, it forms a suitable structure, especially in the form shown in fig. 125. In such cases it is only necessary to counterbrace a few of the central bays.

CHAPTER XV.

BRACED GIRDERS—*continued.*

BRACED GIRDERS WITH CURVED FLANGES.

195. The braced girders hitherto considered have parallel flanges, and this is the most common form. There is another class which have one or both flanges curved or oblique, such girders being frequently used in preference to those with parallel flanges on account of their more graceful appearance, their harmony with surrounding structures, or for some other reason.

In some designs the bottom boom is straight, and the top curved, while in others the top is straight and the bottom curved either concavely or convexly; in some other cases both top and bottom booms are curved or polygonal.

196. Calculation of Stresses in Braced Girders with Curved Flanges.—We have seen that in braced girders with straight, parallel flanges the stresses throughout the girder may be easily calculated by the aid of simple algebraic formulæ, as well as by means of stress diagrams. In the girders we are now considering, algebraic formulæ cannot be conveniently applied, on account of the varying angles of inclination of the several parts of the structure, and it will be necessary to have recourse to carefully constructed stress diagrams in order to determine the stresses, at the same time checking the results thus obtained, when practicable, by moments or other analytical methods.

197. Bowstring Girders.—The most common form of curved braced girder is that in which the bottom boom is straight and the top curved; this is known as the "bowstring girder," and the load is carried on the bottom boom. One advantage possessed by this type is that the stresses on the diagonals are small, a large portion of the shearing stress being taken up by the curved boom. This advantage is intensified in large girders with long unsupported struts, which latter are always an expensive item.

In calculating the stresses on curved girders it is assumed

that the portions of the curve between two adjacent apices are straight lines, so that the boom, instead of being a regular curve, is polygonal in form. This assumption does not materially affect

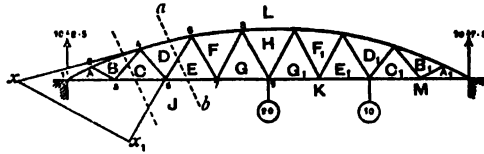

Fig. 128.

the value of the stresses, especially if the apices be tolerably close together.

Example 1.—A bowstring girder of a single system of triangulation is 80 feet span, and 10 feet deep at the centre.

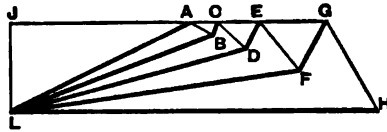
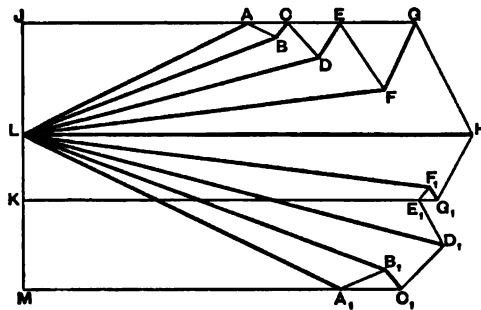

Fig 129.

The bottom boom is divided into eight equal bays of 10 feet each. Determine the stresses on the girders if a load of 20 tons be suspended from the centre of the bottom boom.



[Fig. 130.

Fig. 128, which is drawn to scale, represents the girder. The top bays are all supposed to be equal to each other, except the

two end ones, which are one-half the others. The stress-diagram is shown in fig. 129, which is also drawn to scale.

The stresses on the girder are given in Table LII., the correctness of which, it must be remembered, depends on the accuracy with which the diagram is drawn.

It will be noticed that the lines A B, C D, E F, and G H, which are drawn *downwards*, represent tensile stresses; while B C, D E, and F G, which are drawn *upwards*, represent compressive stresses.

TABLE LII.

Flanges, .	LA	LB	LD	LF	LH	AJ	CJ	EJ	GJ
Stress in Tons, } Diagonal Braces, } Stress in Tons, }	+22.6	+24.6	+27.8	+32.8	+40.8	-20.2	-24.0	-28.5	-35.6
	AB	BC	CD	DE	EF	FG	GH		
	-3.2	+1.8	-4.4	+3.6	-7.2	+7.0	-11.2		

It will be noticed that the maximum flange stress occurs at the centre bay of the top flange and the minimum flange stresses occur at the two end bays of the bottom flange. It will also be observed that the difference of the flange stresses in the several bays is not nearly so great as in a girder with parallel flanges similarly loaded.

The stresses in the diagonal braces are also very different to those in a warren girder with a central load. In the latter, as has been shown, the stresses in the braces are constant throughout the girder, while in the bowstring girder they decrease from the centre towards the ends, though not in any fixed ratio. It will also be seen that the compressive stresses in these bars are much smaller than the tensile stresses.

The flange stresses may be checked by the method of moments. Thus, for the centre bay of the top flange, we get—

$$S \times 9.85 = 10 \times 40, \text{ or } S = 40.6 \text{ tons,}$$

which result agrees very closely with that as found from the diagram.

198. Professor Ritter's Method of Moments.—The principle of Professor Ritter's method of moments, or as it is sometimes called "method of sections," may with advantage be applied to

determine the stresses on structures similar to those we are at present considering. This principle is merely an amplification of the ordinary method of moments which has already been frequently used. By it we can determine the stresses, not only in the flanges of a bowstring girder, but also in the lattice bars.

The principle may be applied by drawing "lines of section" cutting the truss in not more than three of its members. These lines of section divide the truss into two parts, one of which is supposed to be removed, and the external forces acting on the other portion alone are considered.

The stress on any one of the three members cut by the line of section may be found by taking moments round the point of intersection of the other two. Adopting this plan, it will be seen that the moments of the stresses on the members which meet at the point above indicated become zero; and it only becomes necessary to equate the moment of the stress on the third member to the algebraic sum of the moments of the external forces acting on the portion of the truss considered.

For example (in fig. 128), draw the sectional line ab cutting the three members LD , DE , and EJ . The portion of the girder to the left of ab is held in equilibrium by the stresses on LD , DE , and EJ , and by the external force represented by the reaction of the left abutment. To find the stress on LD , we must take moments about 5, the point of intersection of the other two; thus—

$$S_{LD} \times 7.2 = 10 \times 20,$$

$$S_{LD} = 27.8 \text{ tons.}$$

To find the stress on EJ , take moments about 6, the point of intersection of LD and DE ; thus—

$$S_{EJ} \times 8.75 = 10 \times 24.94,$$

$$S_{EJ} = 28.5 \text{ tons.}$$

To find the stress on DE , take moments about x , the point of intersection of LD and EJ ; thus—

$$S_{DE} \times x x_1 = 10 \times x 1,$$

$$\text{or } S_{DE} \times 26.5 = 10 \times 9.7,$$

$$\therefore S_{DE} = 3.66 \text{ tons.}$$

It will be seen that the stresses thus found agree with those obtained from the stress diagram.

An advantage which this method possesses over the graphic system is that the stress on any member may be found directly without going to the trouble of finding those on all the members which precede it.

Example 2.—Determine the stresses on the bowstring girder in the previous example, if an additional weight of 10 tons be suspended on the second bottom apex measuring from the right abutment.

In this case the reaction of the left and right abutments are 12·5 and 17·5 tons respectively.

In fig. 130, on a vertical line make $JL = 12·5$ tons, and $LM = 17·5$ tons; $JK =$ weight of 20 tons, and $KM =$ weight of 10 tons. This figure, which is constructed in a manner similar to fig. 129, represents the stress diagram, the portion above the line LH giving the stresses on the left half of the girder, and that below LH those on the right half.

By scaling we get the following table of stresses for the girder:—

TABLE LIII.

Top Flange,	L A	L B	L D	L F	L H	L F ₁	L D ₁	L B ₁	L A ₁
Stress in Tons,	+28·2	+30·8	+34·7	+41·0	+51·0	+46·5	+48·6	+43·1	+39·3
Bottom Flange,	A J	C J	E J	G J	G ₁ K	E ₁ K	C ₁ M	A ₁ M	
Stress in Tons,	-25·2	-30·0	-35·7	-44·5	-47·0	-44·4	-42·1	-35·3	
Diagonal Braces,	A B	B C	C D	D E	E F	F G	G H		
Stress in Tons,	-4·0	+2·3	-5·5	+4·6	-9·0	+8·8	-14·0		
Diagonal Braces,	H G ₁	G ₁ F ₁	F ₁ E ₁	E ₁ D ₁	D ₁ C ₁	C ₁ B ₁	B ₁ A ₁		
Stress in Tons,	-8·4	+2·4	-2·5	-5·0	-7·8	+3·2	-5·5		

The student should check these results by Ritter's method of moments.

199. Bowstring Girder Uniformly Loaded.—Suppose the girder shown in fig. 128 to be uniformly loaded with a distributed live load of $1\frac{1}{2}$ tons per foot. This is equivalent to $12\frac{1}{2}$ tons acting at each apex of the bottom flange, with the exception of the two over the abutments at which $6\frac{1}{2}$ tons act.

The net upward reaction at each abutment = 43·75 tons.

It will form an instructive exercise for the student to determine

the stresses produced on each member of the structure by each load of $12\frac{1}{2}$ tons acting separately; by taking the algebraic sum of the stresses so found, he will get the total stress on each member when the girder is fully loaded.

If W_1, W_2, W_3 , &c., represent the loads of 12.5 tons acting at the apices taken in succession from the left abutment, Tables LIV. and LV., which are lettered to suit fig. 131, will represent the stresses on one-half the girder.

When the total load is acting, the stresses on all the braces are tensile, but when certain bays only are loaded this is not so. The tables help us to find the stresses produced on each member of the girder when the rolling load gradually comes on from one end and passes over it. It will be seen that all the diagonal braces except the two end ones are exposed in this passage of the load, to both compressive and tensile stresses. If, in addition to the live load, there be a dead load on the girder equal to $1\frac{1}{2}$ tons to the foot, the eight centre braces alone will be exposed to both compressive and tensile stresses during the passage of the rolling load, the others being exposed to tensile stresses alone. In such case it will be necessary to counterbrace those central braces only. In bowstring girders of large span where the dead load bears a large proportion to the live load very little counterbracing will be required.

Example 3.—A bridge carrying a double line of railway is 100 feet span, and is supported by two main girders of the Bowstring

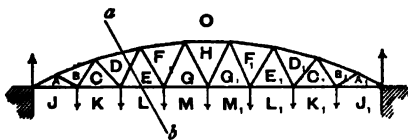

Fig. 131.

type (see fig. 131). Each girder is divided into eight equal bays of 12 feet 6 inches, and the depth at the centre is 12 feet 6 inches. If the dead weight of the bridge be equal to 70 tons, and each train load be equal

to $1\frac{1}{2}$ tons per foot, determine the stresses on the main girders when the bridge is fully loaded with two trains.

Dead load on bridge,	= 70 tons.
Live " "	= $100 \times 2.5 = 250$ "
—	
Total " "	= 320 "
" " one girder,	= 160 "

TABLE LIV.—STRESSES ON FLANGES IN TONS.

Flanges.	W ₁ .	W ₂ .	W ₃ .	W ₄ .	W ₅ .	W ₆ .	W ₇ .	W ₈ .	W ₉ .	W ₁₀ .	Total Load.
OA	+24.6	+21.2	+17.6	+14.1	+10.6	+7.0	+3.5	+98.6			
OB	+26.7	+23.1	+19.2	+15.4	+11.5	+7.7	+4.3	+107.4			
OD	+13.0	+26.0	+21.6	+17.4	+13.0	+8.6	+4.3	+103.9			
OF	+8.5	+17.1	+25.6	+20.5	+15.4	+10.2	+5.1	+102.4			
OH	+6.4	+12.8	+19.2	+25.6	+19.2	+12.8	+6.4	+102.4			
AJ	-22.0	-18.9	-15.7	-12.6	-9.5	-6.2	-3.1	-88.0			
CK	-16.4	-22.6	-18.7	-15.0	-11.2	-7.5	-3.8	-95.2			
EL	-9.9	-19.9	-22.6	-18.1	-13.6	-9.0	-4.5	-97.6			
GM	-7.1	-14.3	-21.4	-22.2	-16.9	-11.1	-5.5	-98.5			

TABLE LV.—STRESSES ON BRACING IN TONS.

Braces.	W ₁ .	W ₂ .	W ₃ .	W ₄ .	W ₅ .	W ₆ .	W ₇ .	W ₈ .	W ₉ .	W ₁₀ .	Total Load.	Maximum Compression.	Maximum Tension.
AB	-3.4	-2.9	-2.5	-2.0	-1.5	-1.0	-0.5	-13.8				...	-13.8
BC	-14.2	+1.7	+1.4	+1.1	+0.9	+0.6	+0.3	-8.2				+6.0	-14.2
CD	+6.0	-4.2	-3.5	-2.7	-2.1	-1.4	-0.7	-8.6				+6.0	-14.6
DE	-5.4	-10.7	+3.3	+2.5	+1.9	+1.2	+0.6	-6.6				+9.5	-16.1
EF	+3.0	+5.9	-5.6	+4.5	-3.4	-2.2	-1.1	-7.9				+8.9	-16.8
FG	-2.9	-5.7	-8.4	+4.4	+3.3	+2.2	+1.0	-6.1				+10.9	-17.0
GH	+1.7	+3.5	+5.2	-7.0	-5.2	-3.5	-1.7	-7.0				+10.4	-17.4

This is equivalent to 20 tons resting at each apex of the bottom flange, and 10 tons coming direct on each abutment.

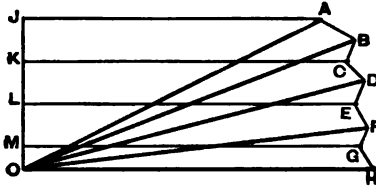

Fig. 132.

Reaction at each abutment = 70 tons.

The stress diagram for the left half of the girder is shown in fig. 132, which is drawn to scale, that of the other half being exactly the same.

It is constructed by taking the vertical line $J O = 70$ tons, and making $J K = K L = L M = 20$ tons, and $M O = 10$ tons.

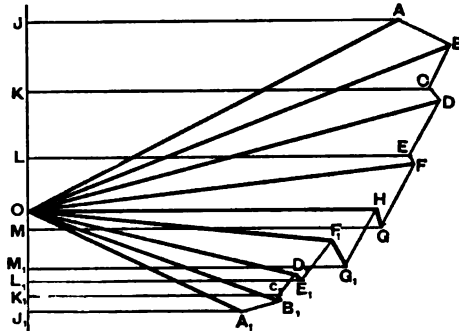

Fig. 133.

Table LVI. gives the value of the stresses.

Method of Moments.—It will be a useful exercise for the student to check the results given in the table by Ritter's method of moments.

For example, by drawing a sectional line $a b$ (fig. 131) we get, by taking moments round the second bottom apex—

$$S_{O_D} \times 9.0 = 70 \times 25 - 20 \times 12.5;$$

$$\text{or } S_{O_D} = 166.6 \text{ tons.}$$

Taking moments about the third top apex we get—

$$S_{B_L} \times 10.7 = 70 \times 30.25 - 20(5.5 - 18.0);$$

$$\text{or } S_{B_L} = 154.0 \text{ tons.}$$

TABLE LVI.

Flanges,	OA	OB	OD	OF	OH	AJ	CK	EL	GM
Stress in Tons,	+157.8	+172.4	+166.5	+163.5	+164.0	-141.0	-153.8	-155.5	-158.5
Diagonal Braces,	AB	BC	CD	DE	EF	FG	GH		
Stress in Tons,	-22.0	-12.5	-12.5	-11.8	-14.0	-9.0	-11.5		

TABLE LVII.

Top Flange,	OA	OB	OD	OF	OH	OF ₁	OD ₁	OB ₁	OA ₁
Stress in Tons,	+122.5	+134.75	+124.25	+113.5	+100.0	+89.0	+81.0	+78.0	+71.0
Bottom Flange,	AJ	CK	EL	GM	G ₁ M ₁	E ₁ L ₁	C ₁ K ₁	A ₁ J ₁	
Stress in Tons,	-109.75	-117.0	-112.0	-103.5	-82.25	-79.75	-72.75	-64.0	
Diagonal Braces,	AB	BC	CD	DE	EF	FG	GH		
Stress in Tons,	-17.75	-15.5	-4.5	-18.5	-2.0	-21.0	+6.5		
Diagonal Braces,	HG ₁	G ₁ F ₁	F ₁ E ₁	E ₁ D ₁	D ₁ C ₁	C ₁ B ₁	B ₁ A ₁		
Stress in Tons,	-20.0	+9.0	-15.0	+3.0	-8.5	-0.75	-10.5		

To find the stress on the diagonal DE take moments about the point of intersection of OD and EL produced.

$$S_{DE} \times 33 = 70 \times 12 - 20(24.5 + 37);$$

$$\text{or } S_{DE} = -11.8 \text{ tons.}$$

These results agree with those found from the stress diagram as nearly as can be expected considering the smallness of the scale.

Example 4.—In the last example determine the stresses when the live load covers the left half of the bridge only.

In this case the distribution of load is equivalent to three loads of 20 tons each resting on the three apices to the left of the centre, one load of 12.1875 tons resting on the centre apex, and three loads of 4.375 tons resting on the three apices to the right of the centre.

The upward reaction at the left abutment = 54.375 tons,

The upward reaction at the right abutment = 30.9375 tons.

In order to construct the stress diagram (fig. 133), draw the vertical line JJ₁ = 85.3124 tons, the total weight resting on the seven apices. Set off JK = KL = LM = 20 tons, MM₁ = 12.1875 tons, and M₁L₁ = L₁K₁ = K₁J₁ = 4.375 tons. Further, make JO = 54.375 tons, and OJ₁ = 30.9375 tons. The stresses are given in Table LVII.

200. Fish-bellied Girder.—An inverted bowstring girder is called a *fish-bellied girder*, and though it is not often used in bridges, it is a common form for cranes both in the lattice form and also with a continuous plate web.

The method of calculating the stresses in a braced girder of this description with a single system of triangulation is similar to that employed in girders of the Bowstring type. The top flange being horizontal, the load rests on this member.

Example 5.—A bridge carrying a single line of railway is 72 feet span, and is supported by a pair of fish-bellied lattice girders with a single system of triangulation, 9 feet deep at the centre; and each divided into eight equal bays of 9 feet. The dead load of the bridge is 56 tons, and the rolling load, consisting of a train of carriages, is equal to 1 ton per foot.

Determine the stresses on the girders—

1. When the train covers the entire length of the bridge.
2. When it covers the left half.

TABLE LVIII.

Flanges,	OA	OB	OD	OF	OH	JA	KC	LE	MG
Stress in Tons,	-63.1	-69.0	-66.5	-65.6	-65.3	+56.4	+61.0	+62.5	+63.0
Diagonal Braces,	AB	BC	CD	DE	EF	FG	GH		
Stress in Tons,	+8.8	+5.2	+5.6	+4.2	+5.1	+4.0	+4.5		

TABLE LIX.—STRESSES.

Top Flange,	JA	KC	LE	MG	M ₁ G ₁	L ₁ E ₁	K ₁ C ₁	J ₁ A ₁	
Stress in Tons,	+47.5	+60.0	+49.0	+47.25	+44.0	+40.25	+37.5	+34.0	
Bottom Flange,	OA	OB	OD	OF	OH	OF ₁	OD ₁	OB ₁	OA ₁
Stress in Tons,	-53.25	-58.0	-53.75	-50.5	-46.75	-43.5	-41.75	-41.0	-37.75
Diagonal Braces,	AB	BC	CD	DE	EF	FG	GH		
Stress in Tons,	+7.0	+6.75	+3.75	+6.5	+2.125	+7.0	-0.5		
Diagonal Braces,	HG ₁	G ₁ F ₁	F ₁ E ₁	E ₁ D ₁	D ₁ C ₁	C ₁ B ₁	B ₁ A ₁		
Stress in Tons,	+6.75	-1.5	+7.0	+0.5	+4.5	+1.5	+5.0		

First Case.—

Dead load on bridge	= 56 tons.
Live " "	= 72 "
—	
Total load on two girders	= 128 "
" " one " "	= 64 "

This is equivalent to 8 tons on each panel. There will, therefore, be seven loads of 8 tons resting on the apices of the top flange of each girder, and two loads of 4 tons resting on the apices immediately over the abutment. The net upward reaction of each abutment = 28 tons. Fig. 134 represents the

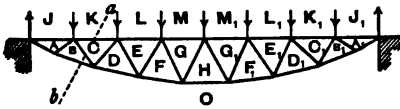

Fig. 134.

girder, and fig. 135 the stress diagram for the left half. The stresses are given in Table LVIII.

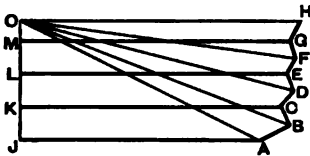

Fig. 135.

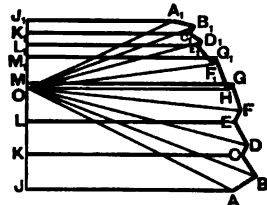

Fig. 136.

All these stresses may be analytically checked by Ritter's method of moments. For example, by drawing the dotted sectional line *a b*, we can find the stresses on the bays *K C*, *B O*, and the diagonal *B C*.

$$S_{K C} \times 5.5 = 28 \times 13.2 - 8 \times 4.2 ;$$

or $S_{K C} = 61$ tons.

$$S_{B O} \times 3.6 = 28 \times 9 ;$$

or $S_{B O} = 70$ tons.

$$S_{B C} \times 9.1 = 28 \times 1.7 ;$$

or $S_{B C} = 5.2$ tons.

It will be seen that in girders of this description, loaded uniformly along the straight flanges, the stresses in the

diagonals are all compressive, whereas in the bowstring girder they are all tensile. This fact of itself renders the lattice fish-bellied girder less economical than the bowstring type.

Second Case.—With this distribution of load, the dead weight is just the same as in the first case, and is equivalent to loads of 3.5 tons resting on each apex of the girder. The live load puts an additional weight of 4.5 tons on the first three apices on the left, and a weight of 2.25 tons on the central apex. These weights produce an upward reaction of 23.5 tons at the left, and 16.75 tons at the right abutment.

To construct the stress diagram, on a vertical line (fig. 136) take $OJ = 23.5$ tons, and $OJ_1 = 16.75$ tons, the reactions of the abutments. Set off $JK = KL = LM = 8$ tons, $MM_1 = 6.75$ tons, and $M_1L_1 = L_1K_1 = K_1J_1 = 3.5$ tons, the loads at the apices taken in succession from the left. The diagram is then constructed in a similar manner to the last, and the stresses are given in Table LIX.

Fig. 137 represents another form of braced curved girder which is frequently employed, not only in bridges, but also in public buildings, where it is used for supporting the roof principals. It will be seen that the top flange is straight and the bottom curved upwards in the arch form.

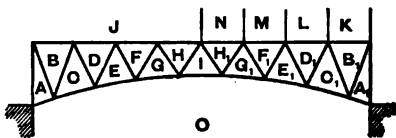

Fig. 137.

This gives it a graceful appearance, which makes it a favourite design for exhibition buildings, &c.

Example 6.—A lattice girder of the type shown in fig. 137 is 80 feet span, 15 feet deep at the ends, and 7 feet 6 inches at the centre. The top flange is divided into eight bays of 10 feet each. Determine the stresses (1) when the girder is loaded with a weight of 20 tons resting at the centre of the top flange; (2) when loaded with 40 tons distributed.

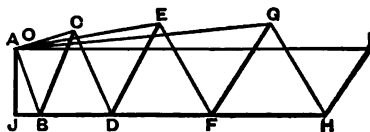

Fig. 138.

Fig. 138 represents a stress diagram of the left half of the girder for the central load. The vertical line AJ is taken equal to the abutment reaction of 10 tons. There is no stress on the two end bays, AO and A_1O_1 , of the bottom flange.

The stresses are given in Tables LX. and LXI.

TABLE LX.—STRESSES FOR CENTRAL LOAD.

Flanges,	JB	JD	JF	JH	OA	OC	OE	OG	OI
Stress in Tons,	+4.1	+14.5	+29.5	+46.2	0	-9.0	-22.0	-37.7	-53.0
Braces,	JA	AB	BC	CD	DE	EF	FG	GH	HI
Stress in Tons,	+10.0	-10.8	+13.5	-14.0	+15.3	-16.0	+16.0	-16.25	+12.0

TABLE LXI.—STRESSES FOR DISTRIBUTED LOAD.

Top Flange,	JB	JD	JF	JH	NH ₁	MF ₁	LD ₁	LB ₁	
Stress in Tons,	+7.0	+23.0	+40.0	+51.0	+51.0	+40.0	+23.0	+7.0	
Bottom Flange,	OA	OC	OE	OG	OI	OG ₁	OE ₁	OC ₁	OA ₁
Stress in Tons,	0	-16.0	-33.7	-47.4	-53.0	-47.4	-33.7	-16.0	0
Braces,	JA	AB	BC	CD	DE	EF	FG	GH	HI
Stress in Tons,	+17.5	-19.0	+23.4	-18.6	+20.8	-15.8	+14.0	-7.8	+3.0
Braces,	H ₁ I	H ₁ G ₁	G ₁ F ₁	F ₁ E ₁	E ₁ D ₁	D ₁ C ₁	C ₁ B ₁	B ₁ A ₁	A ₁ K
Stress in Tons,	+3.0	-7.8	+14.0	-15.8	+20.8	-18.6	+23.4	-19.0	+17.5

CHAPTER XVI.

CRANES — FRAMEWORK.

201. Definition.—A crane is a structure used for lifting weights, and, in addition to the framework, includes the mechanism, such as the gearing, &c. It is only with the former we are here concerned.

There are many varieties of cranes, as regards the structural character of their framework; we will refer to some of the principal, and show how the stresses on their different parts may be determined.

202. Jib Cranes.—A simple form of jib crane, sometimes known as the wharf crane, is that which is shown in skeleton outline in fig. 139.

It consists of three main members, viz. :—

- The vertical post, A D,
- The inclined jib, B C,
- The stay or tie, A C.

The crane post is bedded into the ground, its extremity or toe, D, usually resting in a socket, so that the crane may be turned round, A D, as a vertical axis, in a horizontal direction.

The post acts as a cantilever, the maximum stress on which occurs at B.

The jib, B C, is always exposed to a direct compressive stress, while the stay, A C, is always subjected to a direct tensile stress. Both the post and jib may be made of iron, steel, or wood; while the stay is usually made of wrought iron or steel.

The weight to be lifted is suspended at O, the point of intersection of the jib and stay; the chain from which it is hung passing over a pulley at C and then round the drum at E, which is fixed to the crane post. Usually there is an arrangement by means of which the jib may be raised or lowered—turning round its foot, B—by shortening or lengthening the stay. With a single pulley at C, the tension on the chain is always

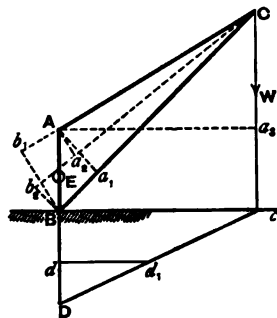

Fig. 139.

supposed to be equal to the weight lifted. Practically, however, this is not the case, on account of the friction in the pulley. The stress on EC is always greater than W when the weight is being lifted, and less when the weight is being lowered. If the pulley is not in good working order and properly lubricated the difference in stress may be considerable.

203. External Forces acting on the Crane.—The crane as a whole, is held in equilibrium by three external forces, the weight of the frame itself being supposed to be omitted.

- 1st. The vertical weight W .
- 2nd. The reaction of the toe-plate at D .
- 3rd. The horizontal pressure against the curb-plate at B .

The 1st acts vertically downwards through O ; the 2nd is the resultant of two forces acting at D , the first of which acts ver-

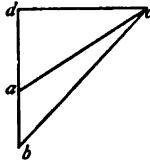

Fig. 140.

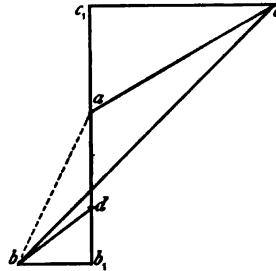

Fig. 141.

tically upwards and is equal to W , and the second is the horizontal reaction of the toe-plate. The amount and direction of this 2nd force may be found thus:—Set off the line Dd to any scale, = W . Draw the horizontal line dd_1 ; then dd_1 represents the horizontal reaction of the toe-plate, and the line Dd_1 will represent its total reaction at D .

The 3rd force acts along the horizontal line Bc , and as the three forces above mentioned keep the crane in equilibrium, they must all pass through one point c , and their intensities are proportional to the three sides of the triangle DBC .

We have, therefore, the following practical method of finding the 2nd and 3rd forces when W is known:—Draw the vertical line Cc , intersecting the horizontal line through B in c . Join Dc . Then the horizontal pressure against the curb is repre-

sented by the line Bc ; the reaction of the toe-plate by the line cD , and the weight W by BD .

204. Stresses on Jib Crane when the effect of the Chain is not considered.—The stresses on the different members of the crane may be most conveniently found by graphic construction, though they may be also calculated by the method of moments.

In the following explanation we will assume the chain EC to be altogether omitted, the weight W being supposed to be hung from the point C .

In fig. 140 take the vertical line ab to represent the weight W ; through its extremities draw ac , bc parallel respectively to the members AC and BC of the crane; ac will then represent the tensile stress on the stay AC , and bc the compressive stress on the jib BC .

The vertical post is acted upon by a transverse stress, and may be considered as a loaded cantilever; or, more strictly speaking, it resembles a girder supported at its extremities A and D and loaded at B , at which point the maximum bending moment will occur.

Considering it as a cantilever of length, AB , the load at its extremity A is equal to ac (fig. 140), and acts in the direction AC . This inclined pull may be resolved horizontally and vertically. Through c draw the horizontal line cd , meeting ba produced at d ; cd is the horizontal component of the pull at A , and ad is its vertical component. As the latter force does not affect the bending stress on the post we get the maximum bending moment

$$M_B = dc \times AB.$$

The stresses in the jib and stay may be calculated thus—

Taking moments about A , we get—

$$S_{BC} \times Aa_1 = W \times Aa_3,$$

$$\text{or } S_{BC} = W \cdot \frac{Aa_3}{Aa_1}.$$

Taking moments about B , we get—

$$S_{AC} \times Bb_1 = W \times Bc,$$

$$\text{or } S_{AC} = W \cdot \frac{Bc}{Bb_1}.$$

Example 1.—A crane of the form shown in fig. 139 supports a weight of 10 tons suspended at C . Determine the stresses on the

jib and stay when these members are inclined at angles of 45° and 30° respectively to the horizontal. Find also the maximum bending moment on the vertical post; its length above ground being 15 feet.

Take the vertical line ab (fig. 140), equal to 10 tons. We then have, by scaling—

$$S_{AC} = ac = -27.3 \text{ tons,}$$

$$S_{BC} = bc = +33.5 \text{ tons.}$$

These results may be checked analytically thus—

Taking moments about A, we get—

$$S_{BC} \times A a_1 = 10 \times A a_2.$$

Now, $A a_1 = AB \times \sin ABC = 15 \times \sin 45^\circ = 10.61$ feet,

and $A a_2 = 35.5$,

$$\therefore S_{BC} = 10 \times \frac{35.5}{10.61} = 33.5 \text{ tons.}$$

Taking moments about B, we have—

$$S_{AC} \times B b_1 = 10 \times Bc;$$

and as $B b_1 = AB \times \sin 60^\circ = 13$ feet,

$$S_{AC} = 10 \times \frac{35.5}{13} = 27.3 \text{ tons.}$$

cd (fig. 140) is equal to the horizontal component of the tension on $A C = ac \times \sin 60^\circ = 23.6$ tons.

The post AB may, therefore, be considered as a cantilever 15 feet long with a load of 23.6 tons acting at its extremity, in a direction perpendicular to its length. If M_B = bending moment at B, we get—

$$M_B = 23.6 \times 15 = 354 \text{ foot-tons.}$$

205. Stresses on Jib Crane when the Effect of the Chain is taken into Account.—If the chain be considered, the stresses on the crane will be considerably altered. Generally speaking, it has the effect of diminishing the stress on the stay and increasing it on the jib.

Suppose in the previous example that the drum be fixed in such a position that the direction of the chain meets the vertical

post at a point E (fig. 139), midway between A and B. If the chain pass over a single pulley at C, the tensile stress throughout the chain will be constant and equal to the weight lifted (the friction being neglected). In the present case this tension = 10 tons.

Take the vertical line ad (fig. 141) to represent the weight of 10 tons, draw db parallel to the direction of the chain C E and make db equal to 10 tons; the dotted line ab will, therefore, represent their resultant, and drawing ac , bc parallel respectively to AC and BC, these lines will represent the stresses on the stay and jib.

By scale we find—

$$S_{A C} = ac = 22.8 \text{ tons.}$$

$$S_{B C} = bc = 39.0 \text{ ,,}$$

Drawing the horizontals b_1b_1 , c_1c_1 , meeting the vertical ad produced in b_1 and c_1 , we get—

b_1b_1 =	horizontal component of the stress on the	chain EC =	7.8 tons.
c_1c_1 =	,,	,,	stay AC = 19.7 ,,
$b_1b_1 + c_1c_1$ =	,,	,,	jib BC = 27.5 ,,

The vertical post in this case will resemble a cantilever 15 feet long with a weight of 19.7 tons acting at its extremity at right angles to its length, and a weight of 7.8 tons acting in the same direction at its centre E.

It will be noticed that the vertical post, in addition to its being acted upon by horizontal or bending forces, is also exposed to longitudinal tensile stresses, the portion AE being subjected to a tensile stress equal to the vertical component of the stress on AC. This is represented by the line ac_1 (fig. 141) = 11.5 tons.

The portion of the post between B and E is exposed to the tensile stress on the portion AE *plus* the vertical component of the stress on the chain EC, this latter stress = b_1d ; so that the total tensile stress on EB = $ac_1 + b_1d = 17.5$ tons. These upward tensile forces on the post are balanced by the vertical component of the stress on the jib which is represented by the line b_1c_1 ; the excess of this latter force over the upward pull on EB is represented by the line ad , which is equal to the weight of 10 tons. This excess comes on the toe of the post.

The stresses on the jib as found graphically, may be checked by moments, thus—

$$\begin{aligned} S_{BO} \times A a_1 - S_{BO} \times A a_2 &= W \times A a_3. \\ S_{BO} \times 10.61 &= 10 \times 35.5 + 10 \times 5.9 = 414. \\ S_{BO} &= +39 \text{ tons.} \end{aligned}$$

Taking moments about B, we get—

$$\begin{aligned} S_{AO} \times B b_1 + S_{BO} \times B b_2 &= W \times B c. \\ S_{AO} \times 13 &= 10 \times 35.5 - 10 \times 5.9 = 296. \\ S_{AO} &= -22.8 \text{ tons.} \end{aligned}$$

It will be seen from this example and the last that the effect of the tension on the chain CD is to diminish the tension on the stay by $27.3 - 22.8 = 4.5$ tons, and to increase the compression on the jib by $39 - 33.5 = 5.5$ tons.

The maximum bending moment on the post is—

$$M_B = 19.7 \times 15 + 7.8 \times 7.5 = 354.0 \text{ foot-tons,}$$

from which it is seen that the effect of the chain pulling at the centre of the post does not alter the bending moment at B.

The sketch shown in fig. 142 represents a form of jib crane very commonly used, and is somewhat different in construction to that last described. The vertical post, in this case, instead of going into the ground, is fixed to a platform EB, which may be

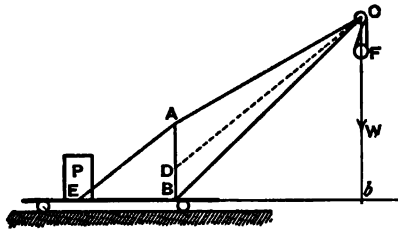

Fig. 142.

be arranged to run on rails; so that the crane may be moved about from one position to another.

In order to relieve the post of the greater portion of its cross-stress, a second stay AE is introduced which connects its extremity with the platform. A load P is placed on the latter with the

object of preventing the crane being turned over when the weight is being lifted. This load P is sometimes arranged so that it can be moved backwards or forwards according as the weight lifted is light or heavy. CD represents the chain which passes round a single pulley at C, and round a second pulley

at F ; with this arrangement of pulleys, the tension on the chain is only one-half the weight lifted; friction not being taken into account.

If Bb be the perpendicular distance between B and the direction in which the weight W acts, then if the weight of the crane itself be neglected, there will be no cross-stress on the crane post when $W \times Bb = P \times BE$.

Example 2.—The post, AB , of the crane shown in fig. 142 is 8 feet high; the jib, BC , and stay, AC , are inclined at 45° and 30° respectively to the horizontal. The stay AE is attached to the platform at E , so that $EB = 10$ feet. Find the stresses on the crane when a weight of 20 tons is suspended from C , the tension on the chain being neglected. Find also the weight of

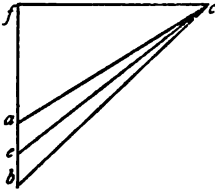

Fig. 143.

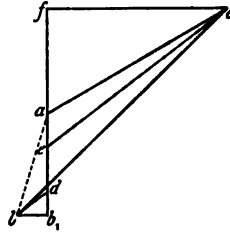

Fig. 144.

the counterpoise P , so that the post may not be exposed to a cross-stress, the weight of the crane and platform being left out of consideration.

Take the vertical line ab (fig. 143) equal to 20 tons; draw ac parallel to AC , and bc parallel to BC .

$$ac = S_{AC} = -56.5 \text{ tons,}$$

$$bc = S_{BC} = +69.25 \text{ tons.}$$

At the point A there are three forces acting, viz., the tensile stresses on AC and AE and the compressive stress on AB . Draw, therefore, through the extremities of the stress line ac , the lines ce , ae parallel respectively to AE and AB , these lines will represent the stresses on those members. By scale we find

$$ce = S_{AE} = -62.5 \text{ tons,}$$

$$ae = S_{AB} = +9.75 \text{ tons.}$$

At the point E we may consider there are three forces acting, viz., the stress on the stay AE , the vertical weight P , and the

stress along the platform E B. By drawing cf parallel to B E, we get—

$$\begin{aligned} cf &= S_{EB} = +48.75 \text{ tons,} \\ cf &= P = +38.75 \text{ tons.} \end{aligned}$$

All the stresses may be checked by the principle of moments. For example, to find P, we get—

$$\begin{aligned} P \times BE &= 20 \times Bb, \\ \text{or, } P &= \frac{20 \times 19}{10} = 38.0 \text{ tons.} \end{aligned}$$

Example 3.—Find the stresses in the last example when the tension of the chain is taken into account. Suppose the direction of the chain to intersect the vertical post at the point D, so that BD = 3 feet.

With a pulley at F the tensile stress on the chain is equal to 10 tons, friction being neglected.

Fig. 144 represents the stress diagram; $ad = 20$ tons; bd parallel to CD represents 10 tons, the stress on the chain. The dotted line, ab , represents the resultant of these two forces, and is equal in magnitude and direction to the total pressure on the pulley at C. The remainder of the diagram is constructed as in the previous example. By scaling, we get—

$$\begin{aligned} ac &= S_{AC} = -52.5 \text{ tons,} \\ bc &= S_{BC} = +75.0 \text{ tons,} \\ ce &= S_{EB} = -58.0 \text{ tons,} \\ ae &= S_{AD} = +9.75 \text{ tons,} \\ cf &= S_{EB} = +45.5 \text{ tons,} \\ cf &= P = +36.0 \text{ tons.} \end{aligned}$$

By drawing bb_1 horizontally, we get—

bb_1 = horizontal component of the stress on the chain = 7.5 tons.

The post A B may, therefore, be considered as a girder supported at A and B, and acted upon by a force equal to bb_1 acting at D, in a direction perpendicular to its length.

The line b_1d = vertical component of the stress on the chain = 6.25 tons. The direct longitudinal compressive stress, therefore, on the portion D B of the post is equal to $ae - b_1d = 3.5$ tons.

It will form an instructive exercise for the student to check these various stresses by the method of moments.

206. **Derrick Crane.**—The Derrick crane, or, as it is sometimes called, the Scotch crane, is shown in outline in fig. 145. It is usually made of wood, and consists of a vertical post, AB , which revolves in a socket at its foot, B . BC is the jib, and AC the tension member, which is frequently a chain, by means of which the jib may be raised or lowered to any angle. AE and AE_1 are two back stays which are generally placed so that EBE_1 is a right angle. The back stays may have their lower extremities

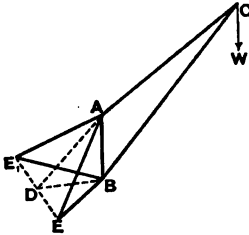

Fig. 145.

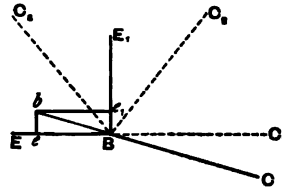

Fig. 146.

anchored to the ground. It is more usual, however, to have them fastened to two horizontal members, BE and BE_1 , which are laid on the ground and weighted.

It will be readily seen that the stresses on the jib and front stay may be determined, as already explained for the ordinary jib crane. The stresses on the back stays vary according to the position of the jib relatively to them: the maximum tension on the stay AE_1 occurs when ABC and AE_1B are in the same vertical plane. Similarly, the maximum tension on AE occurs when A, E, B , and C are all in the same plane. When the tension on AE_1 is a maximum, that on AE is zero, and *vice versa*.

If the plane of ABC lies between these two extreme positions, and it be prolonged to meet E_1E in D , we can find the stress on the imaginary stay, AD , on the assumption that the other two do not exist. Having found this, the stresses on the other two may be found by the triangle of forces, as the first stress is their resultant.

Let fig. 146 represent the plan of the crane shown in fig. 145, BE and BE_1 being at right angles to each other. Let Bb represent the horizontal component of the stress on the main stay AC . Draw $b e, b e_1$ parallel to BE_1 and BE respectively; these lines will represent the horizontal components of the stresses on the back stays AE_1 and AE . These components

being known, the stresses on the stays themselves may easily be found.

If the jib occupy the position shown by the dotted line BC_1 , so that BC_1 is in the same line with BE , then the stress on AE will be a maximum, and that on AE_1 zero.

If the crane be swung round to the position BC_2 , the tensile stress on AE will be diminished, and there will be a compressive stress on AE_1 . The compressive stress on this stay will reach a maximum when the jib is directly over it in the same vertical plane.

If the jib occupy the position shown by the line BC_3 , the stresses on both back stays will be compressive.

207. Sheer Legs.—What is commonly known as “sheer legs” is a kind of crane used by builders and erectors, and possesses the advantage of portability; it being easily moved about from one position to another to suit the requirements of the work, without going to the inconvenience of taking it to pieces, as is necessary with the derrick crane.

It consists of two main posts or struts, AC and BC , of equal length (fig. 147). The lower ends A and B rest on the ground at a considerable distance apart, and the posts gradually taper towards

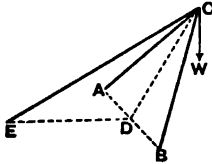

Fig. 147.

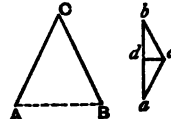

Fig. 148.

each other until they meet at C . These posts are capable of moving in a vertical plane round an imaginary axis, AB . At C , the weight is hung by means of a rope or chain which passes round a pulley-block and thence taken to a crab. The sheer legs are prevented from falling by a stay, EC , or sometimes by several stays. These stays, or, as they are commonly called, “guys,” usually consist of ropes or chains which are fixed by means of spikes to the ground, or are fastened to posts or other convenient objects in the vicinity. They are arranged so as to be easily lengthened or shortened to suit the inclination of the sheer legs.

It is a very simple matter to find the stresses on the legs and stays. Take D , the centre of the imaginary line AB . Join

CD and ED. The two legs may be supposed to be replaced by a single leg, CD. We will then have EC, CD, and the weight W in the same vertical plane, and the stresses on the two former may be found graphically, as previously explained for the jib crane. The stress thus found on the imaginary leg, CD, is the resultant of the stresses on AC and BC.

Let AC, BC, fig. 148, represent the development of the legs; take the vertical line ba to represent their resultant stress as found; draw ac parallel to AC, and bc parallel to BC; then

$$ac = S_{AC}, \quad bc = S_{BC}.$$

As the legs are equal in length and equally inclined to the horizontal, these stresses will be equal.

The horizontal line dc represents the tendency which the legs have to separate.

208. Tripods.—If, in place of the two sheer legs and the guy-rope, there be three legs, we get what is termed a tripod, the three legs slope towards each other, meeting at the apex, and they are arranged so that the projection of the apex falls within the triangle formed by the feet of the posts. In this case the stresses on all the legs will be compressive, and their amounts may be found in the manner indicated in the last case; the weight lifted being the resultant of the stresses.

209. Cranes with Rolling Loads.—In the previous examples of cranes which have been considered, the pulley, round which the chain carrying the weight passes, is fixed, and the jib or legs, to which the pulley is fixed, can be raised or lowered to suit the requirements of the work. In other kinds of cranes this is not the case, and instead of the jib being movable the pulley supporting the weight is attached to a movable carriage, which travels backwards and forwards on a horizontal platform.

Fig. 149 represents a skeleton outline of a crane of this kind. The horizontal member AB usually consists of two beams placed side by side with a space between them. A carriage carrying the pulley from which the weight is slung travels along rails fixed on AB, or otherwise, and may occupy any position between the extremities A and B. The lifting chain passes round a second pulley placed at A, and thence passes to the barrel of the crab.

A second and smaller chain may be attached to the movable carriage, by means of which the latter may be made to travel backwards and forwards as required. CD is a fixed strut which supports AB, and a back stay or tension-rod supports the vertical post. A very good arrangement is to attach A to an over-

head support, when the stay may be dispensed with. The attachments of A and D may be made by means of pivots working in sockets; the crane can thus be swung round in a horizontal plane. This form of crane is very common in foundries.

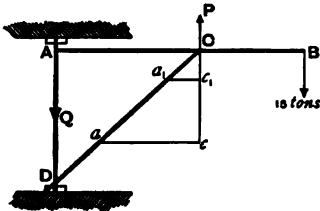

Fig. 149.

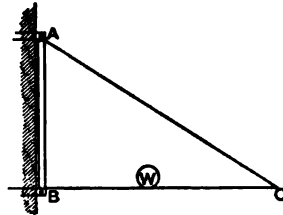

Fig. 150.

It will be seen that the horizontal member AB is exposed to transverse stresses and must be designed to withstand them. When the weight CB is a cantilever, the maximum bending stress being at C . With this position of load there will, practically, be no transverse stress on the portion AC if the connection at C be rigid. If the connection at C be not rigid AB will resemble a girder fixed at A and B , and loaded in an upward direction at C , as explained in Art. 93, Chapter VI.

If the weight rest at C there will be no bending stress on AB , the strut CD receiving the thrust directly. When the weight occupies any position between A and C , the portion AC will resemble an ordinary beam supported at A and C and loaded at an intermediate point, while the projecting portion will not be exposed to any stress. In addition to the bending stresses developed in AB there will be a direct longitudinal stress in the portion AC , equal to the horizontal component of the thrust in CD .

Fig. 150 represents a useful form of crane for lifting light weights and may be worked by hand. It may be fixed to a vertical pillar or wall by means of two brackets in which the vertical member may rotate.

The weight travels on a carriage along the horizontal member BC , which latter resembles an ordinary girder supported at B and C and traversed by a rolling load. In addition to the bending moments developed in BC , there will be a direct longitudinal thrust equal to the horizontal component of the tensile stress on the tie AC .

Example 6.—In the crane shown in fig. 149, a weight of 15 tons

is suspended from the extremity B: Find the stresses on the various parts when $AD = AC = 16$ feet, and $CB = 12$ feet. Find also the stresses when the weight rests midway between A and C—the tension of the lifting chain and the weight of the crane itself being neglected.

If the connection between A B and C D be not rigid, A B will be a lever whose fulcrum may be supposed to be at C.

$$\begin{aligned} \text{If } P &= \text{vertical reaction at C,} \\ Q &= \text{tensile stress on A D;} \end{aligned}$$

then, in the first case, we get, by taking moments about A and C in succession—

$$\begin{aligned} P \times 16 &= 15 \times 28, \text{ or } P = 26.25 \text{ tons,} \\ Q \times 16 &= 15 \times 12, \text{ or } Q = 11.25 \text{ tons.} \end{aligned}$$

The bending moment at C is equal to $15 \times 12 = 180$ foot-tons. To find the longitudinal stresses on A C and C D draw the vertical line $Cc = 26.25$ tons, and draw ca parallel to A C.

$$\begin{aligned} C\alpha &= S_{CD} = 37.1 \text{ tons,} \\ c\alpha &= S_{AC} = 26.25 \text{ tons.} \end{aligned}$$

This latter stress is equal to the shearing stress on the pin at A.

The pressure on the socket at D = $26.25 - 11.25 = 15$ tons.

When the weight is suspended midway between A and C there is no stress whatever on the portion C B. The bending moment at the centre of A C = $\frac{15 \times 16}{4} = 60$ foot-tons.

The upward reaction at C = $\frac{15}{2} = 7.5$ tons.

The thrust on the post A D = 7.5 tons.

Making $Cc_1 = 7.5$ tons, and drawing the horizontal line $c_1\alpha_1$, we get—

$$\begin{aligned} C\alpha_1 &= S_{CD} = 10.6 \text{ tons,} \\ c_1\alpha_1 &= \text{direct tensile stress on A C} = 7.5 \text{ tons,} \end{aligned}$$

which latter is also equal to the shearing stress on the pin at A.

The pressure at the foot of the post = $7.5 + 7.5 = 15$ tons.

210. **Wharf Crane.**—The form of crane shown in fig. 151 is much used in docks and quays for loading and unloading vessels. It is arranged so that it can revolve in a horizontal plane round a vertical line passing through its foot C. The portion above ground is a curved cantilever, and that below ground a straight cantilever. Cranes of this description are usually made of wrought iron or steel, and may be circular, rectangular, or H-form in their cross-section. When circular they generally consist of bent plates rivetted together. When of the other two forms the top and bottom members or flanges usually consist of plates, while the webs may either be plates or open lattice work, the whole being rivetted together.

This crane is altogether exposed to transverse stresses, which increase in intensity as we proceed from the peak A to the base B, so that in an economical design the depth of the jib ought to be greatest at B, and gradually diminish towards A.

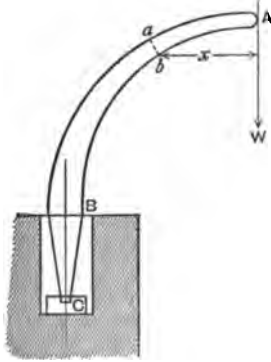

Fig. 151.

The bending moment at any section, $a b$, of the jib at a horizontal distance x from the line of action of the weight may be expressed by the equation $M_{a b} = W x$.

This expression is slightly modified by the tension on the chain, which latter usually passes over pulleys fixed to the back of the jib till it reaches the drum which is fixed near the base.

Example 7.—A crane with bent wrought-iron jib has a weight of 16 tons suspended from its extremity. If the section of the jib be of the H-form, determine the stresses on the flanges at $a b$, the depth $a b$ being 24 inches, and the horizontal distance of b from the vertical line passing through A being 6 feet. What would be a convenient section for the jib if the iron be exposed to a direct stress of 3 tons per square inch gross sectional area?

The portion of the jib $A a b$ is held in equilibrium by the vertical weight of 15 tons suspended at A, and by the tensile and compressive stresses on the flanges at a and b .

Taking moments about b and neglecting the web, we get—

$$S_a \times 2 = 15 \times 6, \text{ or } S_a = 45 \text{ tons.}$$

Allowing a stress of 3 tons per square inch, we shall require $\frac{45}{3} = 15$ square inches of area for the flange.



The section of the jib might be that shown in Fig. 152. fig. 152.

For each flange we have a section of 15.5 square inches, consisting of—	}	1 plate $16 \times \frac{3}{8} = 10.0$ sq. inch.
		2 angles $3 \times 3 \times \frac{1}{2} = 5.5$ „
		15.5 „

The thickness of each web might be made $\frac{3}{8}$ inch.

Example 8.—The braced crane represented in fig. 153 has a weight of 20 tons suspended from *a*. The height of *a* above the ground line = 20 feet, and the depth of the foot *d* below the same line = 10 feet 9 inches. Determine the stresses on the crane.

There are three external forces acting on the crane—viz., the weight of 20 tons which acts vertically through *a*, the reaction

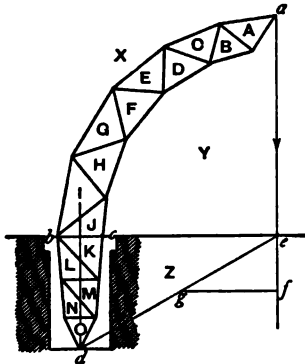

Fig. 153.

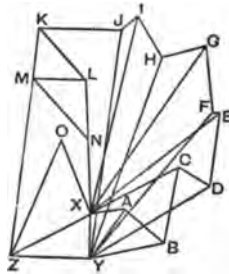

Fig. 154.

at *bc* which acts horizontally, and the reaction at the foot of the crane *d*; these three forces, in order to produce equilibrium, must meet at a single point *e*, so that *ed* will represent the direction of the reaction at the foot.

To represent these forces graphically, draw the vertical line *ef* = 20 tons, and draw *fg* horizontally, meeting *ed* at *g*; *gf* will

then represent the horizontal reaction along bc , and eg will represent the reaction at the foot of the crane. Scaling, we get—

Reaction at $bc = 35.5$ tons.

Reaction at $d = 40.7$ „

Fig. 154 represents the stress diagram. This may be constructed by commencing at the apex a (fig. 153) of the crane and finding the stresses in each member, working downwards. At a there are three forces acting—viz., the vertical load of 20 tons and the stresses on AY and AX . Draw, therefore, the vertical line $XY = 20$ tons, and YA , XA parallel to these members in fig. 153; these lines will represent the stresses on YA and XA respectively. Then proceed in the usual manner until we reach the point c .

At this point there are four forces acting—viz., the stresses on JY , KZ , and JK , and the horizontal reaction at c ; the first two are equal to each other since the members JY and KZ are in one line, and the latter two are also equal.

Drawing YZ horizontally and equal to fg , and JK parallel to YZ and equal to it, we get— $JK =$ stress on $JK = 35.5$ tons, and $KZ =$ stress on KZ . Proceed, then, in the usual manner in order to find the stresses on the portion of the crane below the ground level. As a check on the accuracy of the diagram, the last line drawn—viz., OX parallel to the member OX —must come to the point X .

Scaling the lines in the stress diagram, we get the following table of stresses:—

TABLE LXII.

Outside Flanges, Stresses in Tons,	AX	CX	EX	GX	IX	LX	NX	OX
	-15.0	-43.5	-71.5	-90.0	-88.75	-61.5	-33.5	-35.0
Inside Flanges, Stresses in Tons,	BY	DY	FY	HY	JY	KZ	MZ	OZ
	+31.75	+63.0	+84.5	+95.25	+102.5	+102.5	+81.5	+57.75
Braces, Stresses in Tons,	YA	AB	BC	CD	DE	EF	FG	GH
	+26.5	-21.5	+31.5	-15.0	+31.75	+2.0	+31.0	+19.0
Braces, Stresses in Tons,	HI	IJ	JK	KL	LM	MN	NO	
	+21.0	+8.0	+35.5	-29.5	+23.0	-37.0	+11.0	

CHAPTER XVII.

ARCHES.

211. Arches may be constructed of stone, brick, wood, or metal. Those made of stone and brick are of very ancient origin, and it is not intended to treat on them here, though the mechanical principles regarding their stability are of the same nature as those which apply to iron and steel arches.

It should always be borne in mind by the engineer that in designing metal arches, especially those of the unbraced form, it is not advisable to place too much reliance on mere theoretical rules, as the most refined mathematical investigations will after all give only approximate results.

This being so, it is not as a rule necessary to go to the trouble of finding to a great degree of nicety the exact position of the curve of equilibrium in a rigid arch.

The whole process of finding the stresses in an iron arched rib is based on the assumption that it is of uniform elasticity throughout; this in practice is not so, and this want of uniform elasticity in the material may of itself cause the most elaborate investigation to vary as much as 20 per cent. of the truth.

There are other elements which tend to modify the stresses in arches, the existence of which should not be altogether ignored. The following may be named:—

1. Stresses set up in the arch owing to *alterations in the form of the arch* produced by unequal loading. These stresses are greatest when the rolling load is large compared with the permanent load.

2. Stresses induced by change of temperature. An increase of temperature causes the crown of an arch to rise; that of the Southwark bridge, which has a span of 246 feet and a versine of 23 feet, rose $1\frac{1}{4}$ inches for an increase of temperature equal to 50° Fah.

Increase of temperature causes the spandrels to extend longitudinally, and a vertical space should be provided at the ends for that purpose.

212. *Different Forms of Metal Arches.*—Iron or steel arches may be divided into two classes, viz., *Unbraced* or *Rigid Arches* and *Braced Arches*.

An unbraced arch consists of a single rigid rib, usually made

of cast iron, the stability of which depends upon the stiffness of the rib itself.

Braced arches consist of two ribs, which are braced together by diagonal or other bracing.

It has been seen that when a bowstring girder, consisting of a parabolic bow and horizontal tie, is uniformly loaded, the stresses on the flanges are constant throughout, while the stresses on the diagonal bracing are practically nil, so that these latter may be removed without interfering with the stability of the girder.

If the horizontal tie be also removed, and in its place be substituted the resistance of the abutments, the girder becomes reduced to a parabolic unbraced arch, as shown in fig. 155.



Fig. 155.

The horizontal thrusts of the abutments are substituted for the tension

on the horizontal flange of the girder, and are equal to it in amount.

213. *Linear Arches—Line of Pressures.*—By a *Linear* arch is meant an arch that is incapable of resisting flexure, and one that is supposed to be subjected to direct compressive stresses only. It is needless to say that in practice no iron arch really fulfils these conditions.

By the *line of pressures* is meant that line, the ordinates of which vary as the bending moments for the load which the arch supports. This line is synonymous with the curve of equilibrium for the load, for it is the curve to which a linear arch would have to be adjusted before it could support the given load.

This line inverted corresponds exactly to the curve which a flexible cord would adjust itself to when the given load is applied to it.

In designing rigid iron arched ribs, it is always advisable to allow the rib freedom to turn at its springings by having them rounded and fitting into corresponding bearings. By this arrangement the resulting thrusts at the abutments will pass through the axis of the arch, or approximately so, and the stresses can be determined with much greater accuracy than if the rib be rigidly attached to the abutments. Another advantage of this plan is that the alterations in the form of the arch, whether they arise from passing loads or change of temperature, more readily adapt themselves to these varying conditions.

Figs. 156, 157, and 158 are examples of rigid arches rounded at their extremities and loaded in different ways.

The dotted lines in each case represent the lines of pressures. These lines must pass through the points of application of the loads, and also through the points where the arches are in contact with the abutments. The ordinates of these lines will give the bending moments for the load. If a number of loads of equal value, and placed at equal distances apart, rest on the arch, the line of pressures will approximate to a parabolic curve.

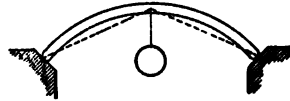

Fig. 156.

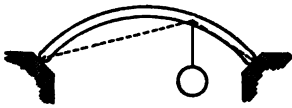

Fig. 157.



Fig. 158.

When the form of an arch corresponds with that of the line of pressures, the stresses on every part will be those of compression only, and the horizontal components of the stresses at every point will be equal to each other and to the horizontal thrust at the abutments.

If an arch of this description be used for supporting a bridge, the roadway would be horizontal, and might be suspended by vertical suspenders from the arch, as shown in fig. 155; or it might be carried above the arch by vertical pillars or spandrels.

- Let l = length of the span of arch,
- v = versine or rise of arch,
- w = load per unit of length.

Then the pressure at the crown of the arch is

$$S_{\text{crown}} = \frac{w l^2}{8 v} \quad . \quad . \quad . \quad . \quad . \quad (1).$$

This expression represents the horizontal component of the pressure at any point of the arch, and it is also equal to the horizontal reaction of the abutments.

The actual compressive stress at any point at a distance x from the centre, when the arch is a parabola, is—

$$S_x = \sqrt{\left(\frac{w l^2}{8 v}\right)^2 + (w x)^2} \quad . \quad . \quad . \quad . \quad . \quad (2).$$

If the tangent to the arch at x be inclined to the horizontal at an angle θ , then

$$S_x = S_{\text{com.}} \times \sec \theta \quad . \quad . \quad . \quad (3).$$

When a single weight W rests on the centre of the arch the horizontal component of the stress throughout the arch = $\frac{Wl}{4v}$ = horizontal reaction of the abutments.

If W rest at a point at a distance x from the centre,

$$\text{Horizontal reaction} = \frac{W(l-2x)}{4v} \quad . \quad . \quad (4).$$

From this it will be seen that no matter how an arch is loaded, we can determine analytically the horizontal reactions and also the total reactions at the abutments, as it is only necessary to find these reactions for each weight and add them together.

214. Different kinds of Stresses in Arches.—When we speak of the *line* of an arched rib we mean its neutral axis, which is the line joining the centres of gravity of the different cross-sections of the rib.

In practice, arches are not linear; the line of pressures for the load does not coincide with the neutral axis of the arch; so that at those points where this coincidence does not occur, in addition to the direct compression, there is a moment of flexure.

Consider the case of an arched rib, hinged at the crown as well as at the abutments, as shown in fig. 159. If this be loaded with a weight W resting on the apex, the curve of pressures will consist of two straight lines AO and BO .

Let l = span, and v = rise.

Compression at crown is

$$S_0 = \frac{Wl}{4v} = \text{horizontal thrust of each abutment.}$$

If the lines of pressure be inclined at an angle θ to the horizontal, the direct compression (S) at any point in the curve of equilibrium is—

$$S = S_0 \times \sec \theta = \frac{Wl}{4v} \cdot \sec \theta \quad . \quad . \quad . \quad (5),$$

θ in this case being constant.

The direct compression at any section D, of the rib is—

$$S_D = S \times \cos \phi \quad . \quad . \quad . \quad (6),$$

where ϕ = angle which the tangent at D makes with the line of pressures.

Substituting the value of S already found, we get—

$$S_D = \frac{Wl}{4v} \sec \theta \cos \phi \quad . \quad . \quad . \quad (7).$$

In addition to this direct compression at D, there is a moment of flexure represented by

$$M_D = S \times h \quad . \quad . \quad . \quad (8),$$

where h = perpendicular distance between D and the line of pressures.

In the present case, as we have seen, S is constant; but S_D varies with the angle ϕ and is a maximum when $\cos \phi = 1$; that is, when $\phi = 0$.

This occurs at that point of the rib at which the tangent is parallel to the line of pressures.

Substituting in equation (8), we get—

$$M_D = \frac{Wl}{4v} \sec \theta \times h = \frac{Wl}{4v} \times h_1,$$

where h_1 = vertical distance between the line of pressure and the neutral axis of the rib at the given section D.

If the arch we are considering be acted upon by a uniformly distributed load, the curve of equilibrium will be a parabola

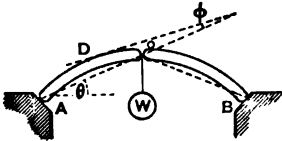

Fig. 159.

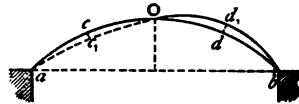

Fig. 160.

which must pass through the springings and the apex of the arch, as it is hinged at these points. If, in addition to this distributed load, the arch be acted upon by a moving load, the curve of equilibrium or line of pressures becomes altered, and is different with the different positions of the moving load. Of course, the greater the fixed load is in proportion to the moving load, the less will be the stress arising from flexure.

In fig. 160 let the parabolic line $acOb$ represent the curve of equilibrium for a uniform load, and suppose this line also to represent the neutral axis of the arch. Each part of the arch will then be in direct compression.

If the left half of the arch be acted upon by a moving load, the curve of equilibrium will assume a position ac_1Od_1b , so that the only points of the arch which are subjected to a direct compressive stress will be a , O , and b ; all the other sections being exposed to a bending moment in addition. The direction of the bending moment on the left half is downwards and in the right half upwards. At the point c , for example, there is—

1st. The direct compressive stress, which is equal to that at O , multiplied by the secant of the angle which the tangent at c makes with the horizontal; and

2nd. The bending stress, which is equal to the product of the latter into the distance cc_1 .

In the same way the total stress at d , or any other point, may be found.

215. Method of Loading Arched Ribs.—The load is usually applied to arched ribs by a series of vertical pillars placed at intervals, the top ends of the pillars being fixed to a horizontal platform which carries the roadway, and the bottom ends being fixed to the rib.

The load on the roadway is thus transmitted directly to the arch. These pillars are termed the spandrils of the arch. If the pillars be placed at equal distances apart dividing the span l , into n equal parts, and if the span be uniformly loaded with w per unit of length, then the direct vertical pressure on each

$$\text{pillar} = \frac{wl}{n-1}.$$

The spandrils may also be formed of inclined bracing.

216. Braced Iron Arches are those in which the arched rib and horizontal rib are connected together by diagonal bracing. In order to determine the stresses on such an arch it is assumed to be pivoted at its crown and springings, so that each half arch with its bracings forms an independent frame or girder. Arches of this kind are frequently made without these pivots or hinges, but with small abutting surfaces instead; the smallness of these surfaces, as compared with the other dimensions of the arch, practically constitutes the arch a hinged one.

Braced arches may be divided into two classes—

1st. Those in which one of the ribs is horizontal and the other arched.

2nd. Those in which both of the ribs are arched.

An example of the former class is given in fig. 161. In a braced arch of this form the load is applied along the top rib, and both this and the bottom, or arched rib, are exposed to compressive stresses throughout their whole length, or they are supposed to be; as doubtless at the centre of the arched member, tensile stresses are developed, though it is impossible to determine their amount by the usual methods employed.

In constructing a braced arch, or, indeed, an arch of any description, it is advisable to have it hinged at three points—namely, at the crown and at the springings. Even if this is not done it is advisable to assume the existence of these hinges in order to arrive at an intelligent solution of the stresses.

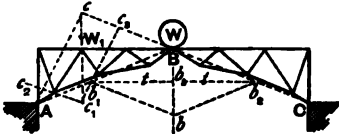

Fig. 161.

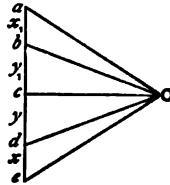

Fig. 162.

With this object the bottom member $A C$ is supposed to be severed at the centre, and hinges are supposed to exist at B , and also at the abutments A and C . A further advantage of the introduction of hinges is, that the arch accommodates itself to alterations in length and form, arising from changes of temperature or passing loads.

The first thing to be done, in order to determine the stresses in such an arch, is to find the amount and direction of the abutment reactions. The horizontal component of these two reactions must in all cases be equal to each other and act in opposite directions, no matter what its form or in what manner it is loaded. If this were not so the arch would move bodily towards that abutment which exerted the least horizontal thrust.

217. **Braced Arch with Single Load.***—In the braced arch, shown in fig. 161, a weight, W , is placed at its centre; if the arch be supposed to be hinged at the centre, B , the directions of the reactions at the abutments must pass through this point along the dotted lines $A B$ and $O B$. Their amounts may be graphically determined by drawing the vertical line $B b = W$, and drawing $b b_1$, $b b_2$ parallel to $B C$ and $B A$. Then we have—

* I am indebted to Mr. Stoney for this solution.

The abutment reaction at A = $B b_1$, and that at C = $B b_2$.

By drawing the horizontal lines $b_1 b_3$ and $b_2 b_3$, we get $b_1 b_3 = b_2 b_3$ = horizontal thrust at B. These lines also represent the horizontal component of the abutment reactions.

Next consider the effect of a single weight, W_1 , resting on the girder at a point away from the centre. The right semi-arch in this case is only acted upon by two external forces, neglecting the weight of the arch itself—viz., the pressure of the left semi-arch at the crown, B, and the reaction of the right abutment. As these forces hold the semi-arch in equilibrium, they must be equal to each other and act in opposite directions. Consequently the reaction of the right abutment must pass through the point B.

Considering the arch as a whole, it is acted upon by three external forces—viz., the reactions at the two abutments and the vertical load, W_1 . To constitute equilibrium these forces must meet in a single point. To find this point, c , produce CB so as to meet the vertical through W_1 in c . Join $c A$; this latter line will represent the direction of the reaction of the left abutment. To determine graphically the amounts of the abutment reactions; on the vertical line through c , set off $c c_1 = W_1$; draw $c_1 c_2$ and $c_1 c_3$ parallel respectively to $C c$ and $A c$;

$c c_2$ = reaction of the left abutment,

$c c_3$ = reaction of the right abutment.

Knowing these abutment reactions, we can determine, by the aid of a stress diagram, the stresses on all the members of the arch in the usual way.

218. Braced Arch Loaded with a Number of Weights.—In the braced arch, shown in fig. 161, suppose the apices to be loaded with weights W_1, W_2, W_3 , &c. The stresses produced in each member of the arch by each weight taken in succession may be found, and by adding all these stresses together, the total stress in each member may be determined when all the weights act simultaneously.

A more direct plan, however, is first to determine the abutment reactions due to all the weights taken together, and then to find the stresses in the usual way by the aid of a stress-diagram.

We will explain how these abutment reactions may be graphically determined.

The braced arch may be considered to be composed of two

separate and independent semi-arches hinged at the crown. These semi-arches are in reality braced girders. We can, therefore, determine by the principle of the lever the vertical reactions at the supports A, B, and C.

Let the vertical reactions at A and B, for the left semi-arch, be x and y respectively, and those at C and B, for the right semi-arch, be x_1 and y_1 .

In fig. 162, on the vertical line $a e$, set off $a b = x_1$, $b c = y_1$, $c d = y$, $d e = x$.

Through b and d draw $b O$, $d O$ parallel to $B C$ and $A B$ respectively; join $a O$, $c O$, and $e O$.

The lines $a O$ and $e O$ will represent both in magnitude and direction the reactions at the abutments C and A, and the line $c O$ represents the stress on the pin at the hinge B.

Example 1.—A wrought-iron braced arch of 100 feet span has a rise or versine of 10 feet, and the depth at the ends measured from the springing to the upper member is 12 feet 6 inches. The upper or horizontal member is divided into eight equal bays of 12 feet 6 inches each, and the bracing consists of isosceles triangles, with the top bays as bases. Find the stresses on the various members of the arch,

1. When a load of 15 tons rests on the centre,
2. When a load of 15 tons rests on an apex 25 feet to the right of the centre,
3. When each apex is loaded with 15 tons.

Fig. 163 represents the arch drawn to scale.

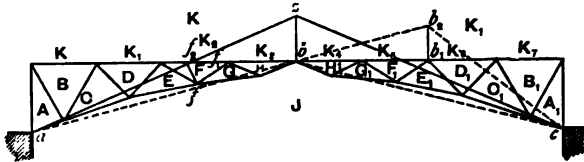

Fig. 163.

Case 1.—Fig 164 is the stress diagram when the load rests on the centre, and is constructed thus:—

Draw the vertical line $x K = 15$ tons. Through x and K draw $x J$, $K J$ parallel to $b c$ and $a b$, the direction of the abutment reactions.

$$\begin{aligned}
 K J &= \text{reaction of left abutment} = 30.9 \text{ tons,} \\
 x J &= \text{reaction of right abutment} = 30.9 \text{ tons.}
 \end{aligned}$$

At the point *a*, fig. 163, there are three forces acting, viz., the abutment reaction which acts in the direction *a b*, and the

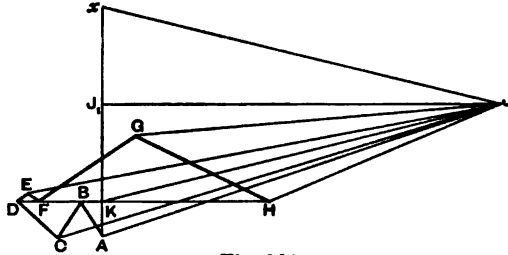

Fig. 164.

stresses on the members A K and A J. The line J K, fig. 164, represents the former. By drawing J A parallel to the member A J, and K A parallel to the member A K, we get—

$$J A = S_{J A} \text{ and } A K = S_{A K}.$$

The remainder of the diagram is constructed in the usual way.

The following table represents the stresses on the left half of the arch, those on the right half being the same :—

TABLE LXIII.

Flanges,	BK	DK	FK	HK	AJ	CJ	EJ	GJ	
Stress in tons,	-1.7	-6.6	-4.8	+13.2	+31.5	+35.1	+36.6	+27.6	
Diagonals,	AK	AB	BC	CD	DE	EF	FG	GH	HJ
Stress in tons,	-2.7	+3.2	-3.5	+4.3	+0.9	-1.2	+8.8	-11.7	+18.4

The horizontal line J J₁ = stress on the pin at *b* = 30 tons. This also is equal to the horizontal component of the reaction at each abutment.

Case 2.—Fig. 165 represents the stress diagram when the load of 15 tons rests at the point *b*₁.

As the reaction of the left abutment passes through *b*, fig. 163, produce *a b* so as to intersect the vertical through *b*₁ at the point *b*₂. Join *b*₂ *c*. This line will represent the direction in which the reaction of the right abutment acts. Take the vertical line K₁ K, fig. 165, = 15 tons; draw K₁ J, and K J parallel to *c b*₂, and *a b*₂; then—

K, J = reaction of right abutment = 18.75 tons,
 K, J = reaction of the left abutment = 15.45 tons.

The horizontal line through J , meeting K_1, K , represents the horizontal component of the reaction of each abutment. This also represents the stress on the pin b at the crown of the arch.

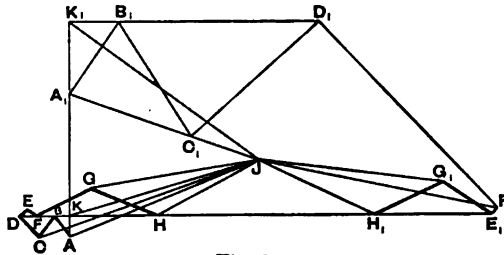

Fig. 165.

In finding the stresses by the diagram we start at the points a and c , fig. 163, in succession, and find the stresses on each member from these points towards the apex. This is clearly shown in the diagram.

As a check on the accuracy of the diagram, the last line drawn for the left half of the arch, viz., H, J , which is drawn parallel to the diagonal H, J , should come to the point J , so as to form a closed polygon. Similarly, the last line drawn for the right half, viz., H_1, J parallel to H_1, J in fig. 163, should also pass through J .

Case 3.—Fig. 166 represents the stress-diagram when each apex is loaded with 15 tons. It is constructed by drawing the vertical line $K, K_7 = 105$ tons, the total load resting on the arch. Set off $K, K_1 = K_1, K_2 = K_2, K_3$ &c., = 15 tons. Each half of the arch is loaded with 52.5 tons. The vertical proportion of the load on the left half borne by the abutment at $a = 22.5$ tons, and at the apex b is 30 tons. Similarly, the vertical reaction of the right abutment at $c = 22.5$ tons, and that on the pin at the apex = 30 tons. Set off, therefore, on the

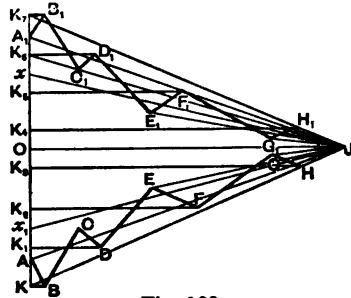

Fig. 166.

vertical line $K K_7$, $K x_1 = K_7 x = 22.5$ tons; then $x_1 O = x O = 30$ tons. Draw $x J$, $x_1 J$ parallel to the dotted lines $c b$ and

b. Join $K J$, $K_7 J$. These lines will represent the reactions at the left and right abutments respectively, both in direction and magnitude. The horizontal line $J O$ will represent the horizontal thrusts at the abutments, and also the stress on the pin at the apex of the arch.

Knowing the abutment reactions the stresses are easily found, as shown in the diagram.

219. Stresses on the Braced Arch by the Principle of Moments.

—The stresses on a braced arch with only one system of triangulation, may be also determined analytically by the aid of the principle of moments. Taking the case we have just been considering—namely, the arch loaded at each apex with 15 tons—let it be required, for example, to determine the stress in the horizontal bay $F K_2$.

Through a and c draw $a z$ and $c z$ parallel to $J K$ and $J K_7$ (fig. 166); $a z$ and $c z$ will represent the directions of the abutment reactions.

Draw $f f_1$ perpendicular to the bay $F K_2$ and $f f_2$ perpendicular to $a z$. The portion of the arch to the left of the line $f f_1$ is held in equilibrium by three external forces and the stress on the bay $F K_2$. The external forces are the abutment reaction equal to 131 tons acting along the line $a z$, and the two vertical loads of 15 tons acting vertically downwards at the two apices. The abutment reaction tends to lift the segment upwards round the point f as a hinge, while the vertical loads at the apices tend to turn it in the opposite direction. Consequently the moment of the stress in $F K_2$ must be equal to the difference of the moments of these external forces.

$$S_{F K_2} \times f f_1 = 131 \times f f_2 - 15 (6.25 + 18.75) = 131 \times 4.8 - 15 \times 25;$$

$$\text{or } S_{F K_2} = 63.4 \text{ tons.}$$

CHAPTER XVIII.

ROOFS.

STRESSES ON ROOF TRUSSES.

220. Roofing may be divided into two parts, namely:—

1. *The Framework.*
2. *The Covering.*

The architect has principally to do with roofs made of timber, while those made of iron or steel usually fall within the province of the engineer.

Timber roofs, as a rule, are employed only in covering buildings of small span, such as houses, churches, and the smaller warehouses and mills.

The sizes of the rafters, purlins, and other members of such roofs are generally fixed by the light of practical experience; the architect in too many cases not troubling himself with the stresses coming upon them.

In those roofs in which a combination of timber and iron is used, the main rafters and struts of the principals are made of timber, while the members in tension are made of wrought-iron or steel rods. Trusses of this composite structure are not, as a rule, to be recommended, for reasons which have been referred to in Art. 18.

The framework of a roof consists of—

1. The main trusses or principals.
2. The purlins or scantlings connecting the principals together.
3. The sash bars, intermediate rafters, wind ties, &c.

Under the head of framework are sometimes included the girders and columns for supporting the roof.

221. Main Principals.—The main trusses or principals may be supported on walls, columns, or girders, and as far as their design is concerned may be classed under two main heads, viz.:—

1. Complete trusses or those in which the pressure on the supports acts in a vertical direction.
2. Arches, braced or otherwise, which produce an outward pressure on the supports.

Trusses of the first-class may be subdivided into two groups:—

(a.) Those with straight rafters, examples of which are given in figs. 164 and 184.

(b.) Those with curved rafters (Bowstring trusses), like that shown in figs. 190 and 192.

Fig. 167*a*, is an example of the second-class, and represents a braced arch.

Principals of the first-class are, like an ordinary braced girder, self-contained, and exert only a vertical pressure on the supports, except it be a side thrust arising from the pressure of the wind. The various members of these principals are exposed to compressive and tensile stresses; the main rafters being in compression while the bottom members or main ties are in tension. The intermediate bracings connecting these together may be exposed to compressive or tensile stresses according to their position.

The load on a roof being constant, or nearly so, it follows that the amount of stress on any particular member does not vary, or varies only in very small degree, except in the case of a light roof when a strong wind is blowing, or when a large accumulation of snow takes place. It is not often, however, that these events occur, so that practically speaking the stresses on the different members are constant.

In principals of the second-class, the stability of the roof depends not only on that of the main ribs themselves, but also on the suitability of the supports to resist a lateral pressure. Generally speaking, arched principals are used only in very large spans, or where a clear headway is required, or to produce architectural effect.

222. Simple Forms of Roof Trusses.—The simplest form of roof truss is the isosceles triangle, shown in fig. 167. The height of the apex above the abutments varies from one-fifth to one-third of the span. The most common being one-fourth or a little more. *A C* and *B C* are the rafters, and *A B* the main tie.

Let *W* = distributed weight on principal,

l = span,

h = height of apex above tie bar or the abutment.

A uniform load *W*, so far as the *direct* stresses on the truss are concerned, is equivalent to $\frac{W}{2}$ acting vertically downwards

at the apex; this produces a vertical reaction at each of the abutments = $\frac{W}{4}$.

Taking moments about the apex, we get—

$$S_{AB} \times h = \frac{W}{4} \times \frac{l}{2}, \text{ or } S_{AB} = \frac{Wl}{8h};$$

$$S_{AC} = S_{BC} = S_{AB} \times \sec \theta = \frac{Wl}{8h} \sec \theta$$

where θ = angle of inclination of the rafters to the horizontal.

In addition to this compressive stress on the rafters, they will be exposed to transverse stresses with a uniform load; if their length be considerable they become deflected, thereby resembling long bent struts. In this form they do not possess much

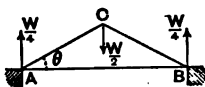

Fig. 167.

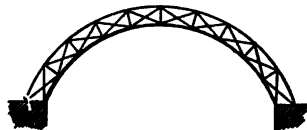

Fig. 167a.

strength; hence the desirability of stiffening them by introducing intermediate bracing. The truss shown in fig. 167 is for this reason only suitable for very small spans.

If the horizontal tie be omitted, there will be an outward horizontal thrust on the abutments = $\frac{Wl}{8h}$.

When the span of the roof is too great for the form of truss shown in fig. 167, further bracing should be introduced, as shown in figs. 168 and 171. In these examples the deflection of the rafters is prevented by the introduction of struts which are attached to their central points e and f . The introduction of these struts, de and df , necessitates the addition of the vertical tension member bd to balance the downward thrusts.

If one of these principals be loaded with a distributed weight W , this weight will be equivalent to a load of $\frac{W}{4}$ on each bay, or to three loads of $\frac{W}{4}$, each resting at the points e , b , and f , and

two loads of $\frac{W}{8}$ resting at a and b ; the upward reaction at each abutment being equal to $\frac{3}{8} W$.

Example 1.—A roof is supported by principals of the form shown in fig. 168, which are 35 feet span and 8 feet 9 inches

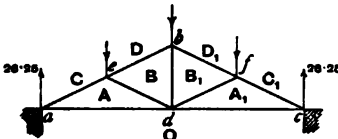

Fig. 168.

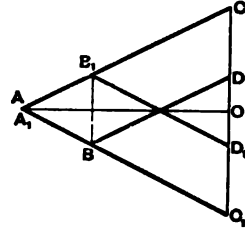

Fig. 169.

in height, and placed 10 feet apart. If the total vertical load on the roof be equal to 20 lbs. per square foot of roof area, determine the stresses on a principal.

$$\text{Slope of roof } a b = \sqrt{(17.5)^2 + (8.75)^2} = 19.57 \text{ feet.}$$

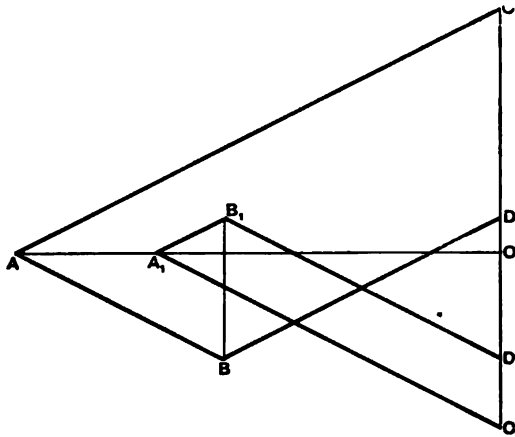

Fig. 170.

Load on one principal = $2 \times 19.57 \times 10 \times 20$ lbs. = 7828 lbs. = 70 cwts. nearly.

This is equivalent to a load of 17.5 cwts. resting on each of the apices e , b , and f , and loads of 8.75 cwts. resting at a and c .

The upward reaction at each abutment = 26.25 cwts.

To construct the stress diagram, on the vertical line CC_1 (fig. 169), set off $CD = DD_1 = D_1C_1 = 17.5$ cwts. Take O the centre of CC_1 , then

$CO = O_1O = 26.25$ cwts. the reactions at abutments.

The further explanation of the stress diagram is not necessary.

By scaling, we get the following stresses on the different members of the principal :—

TABLE LXIV.

Members,	AC	BD	B_1D_1	A_1C_1	AB
Stress in Cwts., . .	+58.75	+39.35	+39.25	+58.75	+19.5
Members,	A_1B_1	AO	A_1O	BB_1	
Stress in Cwts., . .	+19.5	-52.5	-52.5	-17.25	

These results may be checked thus:—By taking moments about e , we get—

$$S_{A_0} \times 4.375 = 26.25 \times 8.75,$$

$$\text{or } S_{A_0} = 52.5 \text{ cwts.}$$

Example 2.—In the last example, if an additional load of 40 lbs. per square foot be distributed over the left slope of the roof, determine the stresses.

In this case the total load at $e = 52.5$ cwts., that at $b = 35.0$ cwts., and that at $f = 17.5$ cwts.

The upward reaction at left abutment = 61.25 cwts., and that at the right abutment = 43.75 cwts.

Proceeding as before (in fig. 170), on a vertical line, make $CD = 52.5$ cwts., $DD_1 = 35$ cwts., and $D_1C_1 = 17.5$ cwts. Also make $CO = 61.25$ cwts., and $OC_1 = 43.75$ cwts., and construct the diagram in the usual way.

The following are the stresses as found by scale :—

TABLE LXV.

Members,	AC	BD	B ₁ D ₁	A ₁ C ₁	AB
Stress in Cwts., . .	+138	+79.5	+79.5	+99.25	+59.0
Members,	A ₁ B ₁	AO	A ₁ O	BB ₁	
Stress in Cwts., . .	+19.5	-122.5	-87.5	-35.0	

By taking moments about *e* and *f* in succession, we get—

$$S_{AO} \times 4.375 = 61.25 \times 8.75, \text{ or } S_{AO} = 122.5 \text{ tons};$$

$$S_{A_1O} \times 4.375 = 43.75 \times 8.75, \text{ or } S_{A_1O} = 87.5 \text{ tons.}$$

Example 3.—Fig. 172 represents the stress diagram of the truss, shown in fig. 171, when loaded similarly to that in Example 1. This truss is similar in every respect to that shown

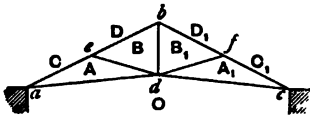

Fig. 171.

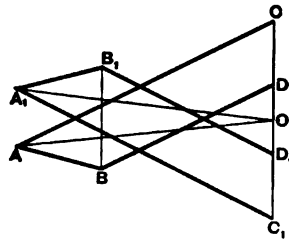

Fig. 172.

in fig. 168, except that the centre of the main tie rod *d* is raised 2 feet.

It will be seen that the stresses in the rafters and main ties are considerably greater than those in fig. 168. The smaller the angle between the rafter and the main tie, the greater will be the stresses on those members, and consequently the less economical the design. A horizontal tie bar gives the most economical results. It is often, however, advisable to raise its central point in order to give increased head room, or on account of appearance.

Figs. 173 and 175 represent further developments of this class of truss in which the main ties may be either horizontal or

inclined, as shown. Roofs of these types made in wrought iron or steel may be used for spans varying between 40 and 100 feet. For greater spans it is advisable to employ principals of different design, usually those of the curved form, such as the bowstring truss or the braced arch, being used.

Example 4.—Find the stresses on a principal, 90 feet span, of the design shown in fig. 173. The apex of the principal is 25 feet above the line of the abutments, and the centre of the main tie is 5 feet above the same line.

Each rafter is divided into five equal bays by the intermediate

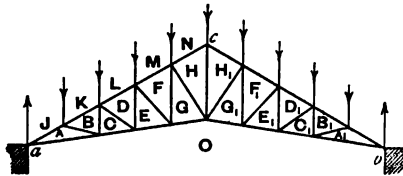

Fig. 173.

bracing. The principals are situated 20 feet apart, and the total vertical weight coming on the roof is equal to 50 lbs. per square foot of horizontal area covered; the wind pressure being neglected.

Load on principal = $90 \times 20 \times 50$ lbs. = 40 tons nearly.

This is equivalent to 4 tons resting at each apex, and the vertical reaction at each abutment = 18 tons.

Fig. 174 is the stress diagram, and is constructed by setting off on the vertical line JJ_1 , $JK = KL = LM$, &c., = 4 tons, and making $JO = J_1O = 18$ tons, the reaction at abutments.

The following Table gives the stresses on one half of the principal, as found from the diagram, the stresses on the second half being the same:—

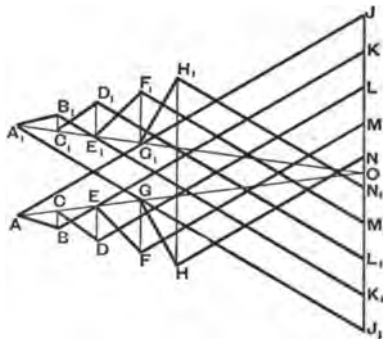

Fig. 174.

TABLE LXVI.

Main Rafters, . . .	J A	K B	L D	M F	N H
Stress in Tons, . . .	+46·6	+41·7	+36·3	+30·9	+26·0
Main Ties,	A O	C O	E O	G O	
Stress in Tons, . . .	-41·6	-36·4	-32·0	-27·3	
Diagonal Struts, . . .	A B	C D	E F	G H	
Stress in Tons, . . .	+4·8	+5·7	+7·1	+8·7	
Vertical Ties,	B C	D E	F G	H H ₁	
Stress in Tons, . . .	-2·0	-4·0	-6·0	-21·0	

Method of Moments.—The stresses thus found graphically may be checked by Ritter's method of moments. The following are the results calculated to one place of decimals. In order to find the stresses on the diagonals and vertical bracing we take moments about the point *a*, and to find the stresses on the main rafter and main tie we take moments about the apices along the main tie and the rafter respectively.

For the diagonals—

$$\begin{aligned} S_{A B} \times 7.4 &= 4 \times 9, \text{ or } S_{A B} = +4.8 \text{ tons.} \\ S_{C D} \times 18.8 &= 4 \times 27, \text{ or } S_{C D} = +5.7 \text{ ,,} \\ S_{E F} \times 30.2 &= 4 \times 54, \text{ or } S_{E F} = +7.1 \text{ ,,} \\ S_{G H} \times 41.2 &= 4 \times 90, \text{ or } S_{G H} = +8.7 \text{ ,,} \end{aligned}$$

For the verticals—

$$\begin{aligned} S_{B O} \times 18 &= 4 \times 9, \text{ or } S_{B O} = -2.0 \text{ tons.} \\ S_{D E} \times 27 &= 4 \times 27, \text{ or } S_{D E} = -4.0 \text{ ,,} \\ S_{F G} \times 36 &= 4 \times 54, \text{ or } S_{F G} = -6.0 \text{ ,,} \end{aligned}$$

For the rafter bays—

$$\begin{aligned} S_{A J} \times 3.48 &= 18 \times 9, \text{ or } S_{A J} = +46.6 \text{ tons.} \\ S_{B K} \times 6.9 &= 18 \times 18 - 4 \times 9, \text{ or } S_{B K} = +41.7 \text{ ,,} \\ S_{D L} \times 10.4 &= 18 \times 27 - 4 \times 27, \text{ or } S_{D L} = +36.3 \text{ ,,} \\ S_{F M} \times 14.0 &= 18 \times 36 - 4 \times 54, \text{ or } S_{F M} = +30.9 \text{ ,,} \\ S_{H N} \times 17.4 &= 18 \times 45 - 4 \times 90, \text{ or } S_{H N} = +26.0 \text{ ,,} \end{aligned}$$

For the main tie—

$$\begin{aligned} S_{\Delta o} \times 3.9 &= 18 \times 9, & \text{or } S_{\Delta o} &= -41.6 \text{ tons.} \\ S_{c o} \times 7.9 &= 18 \times 18 - 4 \times 9, & \text{or } S_{c o} &= -36.4 \text{ ,,} \\ S_{e o} \times 11.8 &= 18 \times 27 - 4 \times 27, & \text{or } S_{e o} &= -32.0 \text{ ,,} \\ S_{g o} \times 15.8 &= 18 \times 36 - 4 \times 54, & \text{or } S_{g o} &= -27.3 \text{ ,,} \end{aligned}$$

Example 5.—A roof 50 feet span, principals 10 feet apart, of the form shown in fig. 175, is loaded vertically with 35 lbs. per square foot of roof area, distributed over its whole surface. In addition to this there is a horizontal wind pressure of 40 lbs. per square foot on the right slope.

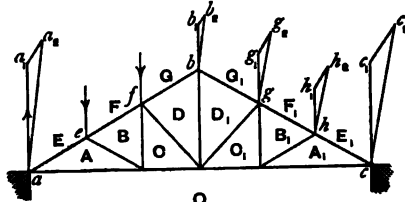

Fig. 175.

Determine the stresses on the principal, the angle which the rafters make with the horizontal being 30° .

$$\text{Length of slope of roof} = 25 \sec 30^\circ = 29 \text{ feet nearly.}$$

$$\text{Distributed dead load on roof} = 2 \times 29 \times 10 \times 35 \text{ lbs.} = 9 \text{ tons nearly.}$$

This is equivalent to five vertical loads of 1.5 tons each resting on the apices $e, f, b, g,$ and $h,$ and two loads of 0.75 ton each resting at a and c directly over the abutments.

By referring to the table on wind pressures (see Art. 229, Chap. XIX.) we find that a horizontal wind pressure of 40 lbs. per square foot acting in a direction normal to the length of the roof is equivalent to a force of 26.4 lbs. per square foot acting normally to the slope of the roof.

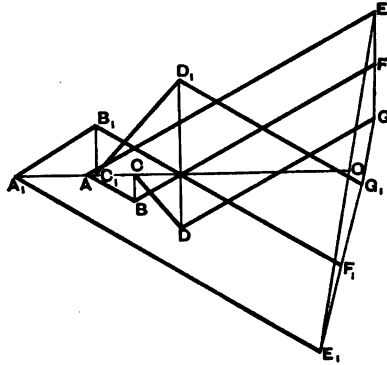

Fig. 176.

We have, therefore—

$$\begin{aligned} \text{Wind pressure acting on one principal} &= 29.0 \times 10 \times 26.4 \text{ lbs.} \\ &= 3.42 \text{ tons.} \end{aligned}$$

This is equivalent to pressures of 1·14 tons acting at the apices *g* and *h*, a pressure of 0·57 ton acting at *b* and *c*, all in a direction at right angles to *bc*: the pressure on *c* may be neglected, as it comes directly on the abutment.

Let *R* and *R*₁ = reactions from wind pressure at right and left abutments, we get by taking moments about *a* and *c*—

$$R \times 43\cdot3 = 0\cdot57 \times 14\cdot3 + 1\cdot14 (24 + 33\cdot6),$$

$$\text{or, } R = 1\cdot7 \text{ tons,}$$

$$\text{and } R_1 = 2\cdot85 - 1\cdot7 = 1\cdot15 \text{ tons.}$$

The vertical reaction at each abutment from the statical load = 3·75 tons. Draw the vertical lines *bb*₁, *gg*₁, and *hh*₁, each = 1·5 tons; and *bb*₂, *gg*₂, *hh*₂ in a direction perpendicular to *bc*, and make *bb*₂ = 0·57 ton; *gg*₂ = *hh*₂ = 1·14 tons; join *bb*₂, *gg*₂, and *hh*₂; then these lines will represent graphically the total loads acting at *b*, *g*, and *h*.

Again, draw the vertical lines *aa*₁ and *cc*₁ = 3·75 tons, and *aa*₂, *cc*₂ perpendicular to *bc*, making *aa*₂ = 1·15 tons, and *cc*₂ = 1·7 tons; then *aa*₂ and *cc*₂ represent the total reactions at the left and right abutments.

In order to construct the stress diagram take the line *EO* (fig. 176) equal and parallel to *aa*₂, and *E*₁*O* equal and parallel to *cc*₂, and proceed in the usual manner to construct the stress diagram. The following table gives the stresses:—

TABLE LXVII.

Rafters, . . .	A E	B F	D G	D ₁ G ₁	B ₁ F ₁	A ₁ E ₁
Stress in Tons, .	+9·5	+8·0	+6·4	+6·1	+8·2	+10·25
Diagonal Struts,	A B	C D	C ₁ D ₁	A ₁ B ₁		
Stress in Tons, .	+1·52	+2·05	+3·65	+2·65		
Main Ties, . . .	A O	C O	C ₁ O	A ₁ O		
Stress in Tons, .	-7·6	-6·3	-7·35	-9·7		
Vertical Ties, . .	B C	D D ₁	B ₁ C ₁			
Stress in Tons, .	-0·8	-4·25	-1·35			

The student should check these results by the principle of moments.

Example 6.—Fig. 177 represents a cantilever truss, 20 feet span, and is uniformly loaded with 8 tons. Determine the stresses: the inclination of the top member being 30° to the horizontal.

The load is equivalent to 2 tons resting at b , c , and d , and 1 ton resting at a and e .

The cantilever exerts a horizontal thrust against the wall at the point g , and a pull at e . This pull may be taken up by a bolt, ef , passing through the wall.

The stress diagram is shown in fig. 178.

On the vertical line OJ make $OG=1$ ton, the load acting at a . $GH=HI=IJ=2$ tons, the loads acting at b , c , and d .

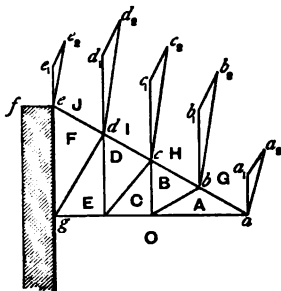

Fig. 177.

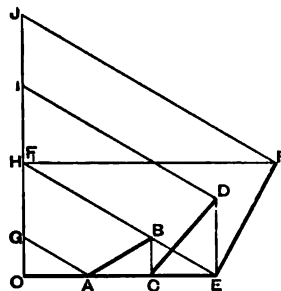

Fig. 178.

The diagram is then constructed in the usual way, and the stresses are given in Table LXVIII. It will be noticed that the inclined member ae is in this case in tension, while the horizontal member ag is in compression, the reverse of what occurs in an ordinary principal supported at the two ends. The inclined bracings are struts, and the vertical bracing ties as before. The horizontal line FF , (fig. 178) represents the tensile stress on the tension bolt ef . This may be checked by taking moments about g , thus:—

$$S_{ef} \times 11.54 = 1 \times 20 + 2 (15 + 10 + 5), \text{ or } S_{ef} = 6.93 \text{ tons.}$$

If, in addition to the vertical loads on the cantilever, there be

a wind pressure equal to 4 tons, acting in a direction normal to the slope of the roof, the stresses may be determined thus:—

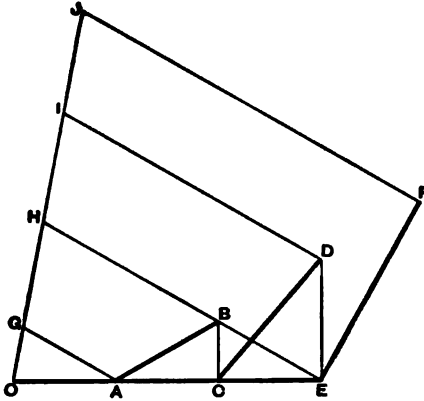

Fig. 179.

$a e$, and equal to the wind pressures at these apices; then

The wind pressure is equivalent to 1 ton, acting at each of the apices b , c , and d , and $\frac{1}{2}$ ton acting at a and e ; that at e will not affect the stresses. Draw the vertical lines $a a_1$, $b b_1$, $c c_1$, and $d d_1$ to represent the vertical loads at these points, and draw $a_1 a_2$, $b_1 b_2$, $c_1 c_2$, and $d_1 d_2$ in a direction perpendicular to

TABLE LXVIII.

Members of Truss.	Stress in Tons from Dead Load.	Stress in Tons from Wind Pressure.	Stress in Tons from Total Load.
AG	-2.0	-0.87	-2.87
BH	-4.0	-1.45	-5.45
DI	-6.0	-2.0	-8.0
FJ	-8.0	-2.55	-10.55
AO	+1.74	+1.0	+2.74
CO	+3.48	+2.0	+5.48
EO	+5.22	+3.0	+8.22
AB	+2.0	+1.17	+3.17
CD	+2.7	+1.5	+4.2
EF	+3.5	+2.0	+5.5
BC	-1.0	-0.57	-1.57
DE	-2.0	-1.17	-3.17

$a a_2$, $b b_2$, $c c_2$, and $d d_2$ will represent the total loads at the different apices. In fig. 179 draw $O G$, $G H$, $H I$, and $I J$ equal and parallel to the loads at a , b , c , and d , and construct the stress diagram as before. The complete stresses are given in Table LXVIII.

The main tie bar of a principal, instead of forming one or two straight lines, may be arranged so as to form several, as shown in fig. 180; the feet of the verticals in such case are usually arranged so as to lie in a circular or elliptical curve. This serves the purpose of giving the principal a graceful appearance, and is frequently adopted with this object.

Example 7.—Fig. 180 represents a principal 45 feet span and 15 feet rise at the apex; the centre point of the main tie having a rise of 4 feet 6 inches, and the feet of the verticals lying in a circular curve. Fig. 181 represents a stress diagram for this principal when a weight of 2 tons rests on each apex; the principal being symmetrically loaded, the stresses on each half will be the same as shown in Table LXIX.

Fig. 182 represents a stress diagram for the same principal when an additional weight of snow equivalent to 3 tons, or 1 ton per bay, rests on the right slope. Under these conditions the loading is equivalent to weights of 2 tons resting at d and e ; $2\frac{1}{2}$ tons resting on the apex c , and weights of 3 tons resting at f and g .

Reactions at left and right abutments are 5.75 tons and 6.75 tons.

In fig. 182 make $O F = 5.75$ tons, and $O F_1 = 6.75$ tons.

Set off $F G = G H = 2$ tons, $H H_1 = 2.5$ tons, and $H_1 G_1 = G_1 F_1 = 3$ tons. The stresses are given in Table LXIX.

Fig. 183 represents a form of truss belonging to a different family or series to those we have been considering. It has no

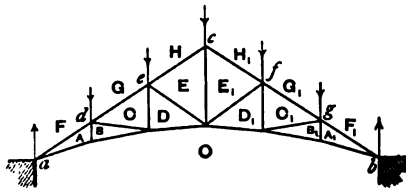

Fig. 180.

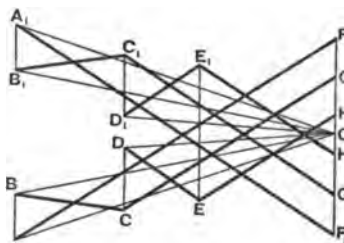

Fig. 181.

vertical members. The form shown may be used for small spans up to about 40 feet when made in wrought iron or steel. It may also be used as a composite truss; the rafters being made of

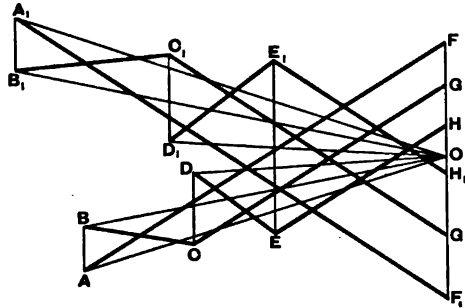

Fig. 182.

wood, the struts of wood or cast iron, and the ties of wrought iron or steel.

TABLE LXIX.

Members.	Stress in Tons with Uniform Load.	Stress in Tons with additional Load of Snow.	Members.	Stress in Tons with Uniform Load.	Stress in Tons with additional Load of Snow.
A F	+17·8	+20·4	A ₁ O	-15·7	-21·2
C G	+11·85	+14·3	A B	-2·1	-2·2
E H	+7·7	+9·8	C D	-2·9	-3·3
E ₁ H ₁	+7·7	+9·6	E E ₁	-6·5	-8·1
C ₁ G ₁	+11·85	+15·7	D ₁ C ₁	-2·9	-4·0
A ₁ F ₁	+17·8	+24·1	B ₁ A ₁	-2·1	-2·6
A O	-15·7	-17·9	B C	+5·1	+5·1
B O	-15·2	-17·3	D E	+4·3	+4·7
D O	-9·9	-11·9	E ₁ D ₁	+4·3	+6·3
D ₁ O	-9·9	-13·1	C ₁ B ₁	+5·1	+7·1
B ₁ O	-15·2	-20·5			

Example 8.—Determine the stresses on the truss shown in fig. 183 ; the span being 35 feet, height of apex 8 feet 9 inches, and height of the horizontal tie 1 foot 9 inches.

It supports a uniformly distributed load of 6 tons. This load is equivalent to three loads of 1·5 tons resting on the apices *d*, *c*, and *e*, and two loads of 0·75 ton resting at *a* and *b*.

Net vertical reaction at each abutment = 2·25 tons.

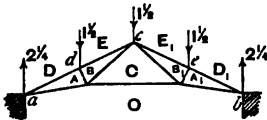

Fig. 183.

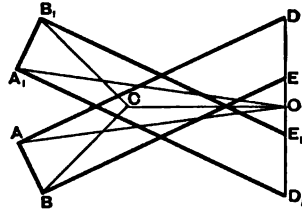

Fig. 184.

Fig. 184 represents the stress diagram, and the following are the stresses :—

TABLE LXX.

Members,	AD	BE	B ₁ E ₁	A ₁ D ₁	AO	BC
Stress in Tons,	+7·76	+7·09	+7·09	+7·76	-7·02	-3·48
Members,	CO	CB ₁	A ₁ O	AB	B ₁ A ₁	
Stress in Tons,	-3·8	-3·48	-7·02	+1·33	+1·33	

The results may be checked by moments.

Thus to find stress on the horizontal tie ; by taking moments about the apex we get—

$$S_{CO} \times 7 = 2 \cdot 25 \times 17 \cdot 5 - 1 \cdot 5 \times 8 \cdot 75,$$

$$\text{or } S_{CO} = 3 \cdot 75 \text{ tons.}$$

The form of truss shown in fig. 185 is merely a development of the last, and may be used for larger spans, say up to 45 or even 50 feet. Instead of each rafter being stiffened by one strut, two are introduced ; the points where they intersect the rafter dividing it into three equal bays.

Example 9.—Draw a stress diagram for a principal 50 feet span similar to that shown in fig. 185, the height of the apex from the wall plate being 13 feet, and that of the central horizontal tie being 1 foot 6 inches. The principals are situated 15 feet apart, and the vertical load on the roof is equal to 36 lbs. per square foot of the horizontal area covered.

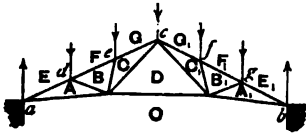

Fig. 185.

Weight on each principal = $50 \times 15 \times 36$ lbs. = 12 tons nearly.
 This is equivalent to a weight of 2 tons resting at each of the five apices of the principal.

Vertical reaction at each abutment = 5 tons.

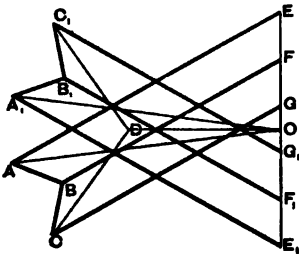

Fig. 186.

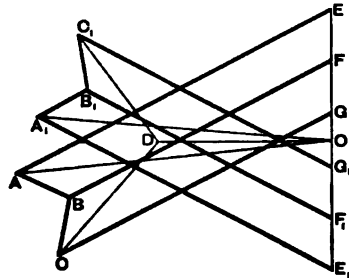

Fig. 187.

Fig. 186 is the stress diagram. By scale we get—

TABLE LXXI.

Members,	AE	BF	CG	C ₁ G ₁	B ₁ F ₁	A ₁ E ₁	AO	CD
Stress in Tons,	+13.6	+11.2	+11.8	+11.8	+11.2	+13.6	-12.1	-6.0
Members,	DO	C ₁ D	A ₁ O	AB	BC	C ₁ B ₁	B ₁ A ₁	
Stress in Tons,	-6.6	-6.0	-12.1	+2.3	+2.3	+2.3	+2.3	

By taking moments about the apex we get—

$S_{D_0} \times 11.5 = 5 \times 25 - 2(8.3 + 16.6)$, or $S_{D_0} = 6.52$ tons,
 which agrees very nearly with the result found by the diagram.

Example 10.—In the last example, if the left slope of the roof be covered, in addition, with snow weighing 6 lbs. per square foot of horizontal area, determine the stresses on the truss.

Weight of snow on principal = $25 \times 15 \times 6$ lbs. = 1 ton nearly.

This is equivalent to $\frac{1}{3}$ ton on each bay on the left slope, so that the total load on the principal will be distributed as follows:—

At the points *d* and *e* there will be loads of $2\frac{1}{3}$ tons, at *c* of $2\frac{1}{2}$ tons, and at *f* and *g* of 2 tons.

Reactions at left and right abutments are 5.58 tons, and 5.25 tons. Fig. 187 represents the stress diagram.

$O E = 5.58$ tons, $O E_1 = 5.25$ tons, $E F = F G = 2\frac{1}{3}$ tons,

$G G_1 = 2\frac{1}{3}$ tons, $G_1 F_1 = F_1 E_1 = 2$ tons.

The following are the stresses:—

TABLE LXXII.

Members,	A E	B F	CG	C ₁ G ₁	B ₁ F ₁	A ₁ E ₁	A O	C D
Stress in Tons,	+15.4	+12.6	+13.3	+12.2	+11.5	+14.0	-13.75	-7.0
Members,	D O	C ₁ D	A ₁ O	A B	B C	C ₁ B ₁	B ₁ A ₁	
Stress in Tons,	-7.3	-5.7	-12.6	+2.8	+2.8	+2.4	+2.4	

Taking moments about *c* we get—

$S_{D_o} \times 11.5 = 5.25 \times 25 - 2(8.3 + 16.6)$, or $S_{D_o} = 7.1$ tons,

which agrees very nearly with that found from the diagram.

223. French Truss.—The form of principal shown in fig. 188 is generally known as the “French Truss.” Figs. 183 and 185 are modifications of it. This is a favourite truss for spans varying from 40 to 80 feet.

Example 11.—Determine the stresses on the principal shown in fig. 188: the span is 70 feet, slope of rafters to horizontal = 30° , rise of horizontal tie-bar above wall-plate, 3 feet. The principals are placed 16 feet apart, and the vertical load on the roof is assumed at 50 lbs. per square foot of horizontal area.

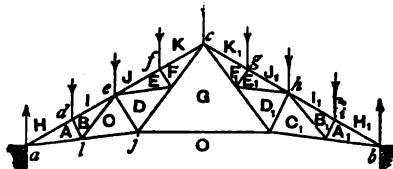

Fig. 188.

Total load on principal = $70 \times 16 \times 50$ lbs. = 25 tons.

This is equivalent to loads of 3.125 tons acting at each of the points $d, e, f, c, g, h,$ and $i,$ and loads of 1.5625 tons acting at a and b directly over the abutments.

As the stress diagram for this principal involves a little difficulty, we shall describe it in detail.

Vertical reaction at each abutment = 10.93 tons.

In fig. 189, on a vertical line make $H O = O H_1 = 10.93$ tons.

Set off $H I = I J = J K = K K_1 = K_1 J_1 = J_1 I_1 = I_1 H_1 = 3.125$ tons.

Consider the stresses on the left half of the truss.

Draw $H A$ parallel to rafter $a c,$ and $O A$ parallel to main tie $a j.$ Next consider forces acting at $d;$ draw $I B$ parallel to

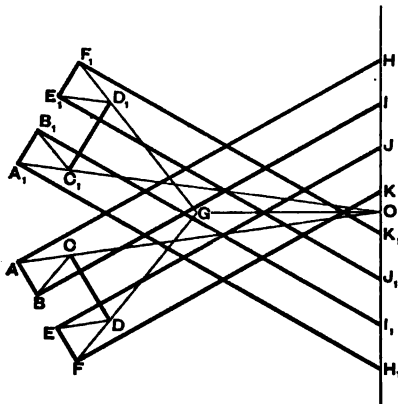

Fig. 189.

rafter, and $A B$ parallel to strut $A B$ —these lines give the stresses on those members. Next consider stresses acting at the point $l;$ all these are known except those on $B C$ and $C O;$ draw $B O$ (fig. 189) parallel to $B C,$ meeting $A O$ in $O,$ then $B O = S_{B C}$ and $C O = S_{C O}.$ At this point the difficulty occurs. If we consider either the points e or j we find that there are three unknown forces acting at each of them, and consequently by the ordinary method the forces

are indeterminate, and it will be necessary to make an assumption of the stress upon one of the members. From the position of the strut $C D$ it might reasonably be supposed that the stress upon it is double that on the strut $A B,$ and the correctness of this assumption is subsequently verified by the stress polygon closing. Consider then the forces acting upon $e,$ two of which only are unknown. Draw $C D$ (fig. 189) parallel to $C D,$ and make it equal to twice $A B.$ Through D draw $D E$ parallel to $D E,$ and through J draw $J E$ parallel to the main rafter and meeting $D E$ at $E.$ We have then $D E = S_{D E}$ and $J E = S_{J E}.$ The remainder of the diagram presents no difficulty. By drawing $D G$ parallel to tie $D G,$ and $O G$ parallel to the horizontal tie $G O,$ we get $D G = S_{D G},$ and $G O = S_{G O},$ and so on for the remainder of the diagram.

The stresses on the right half of the principal are the same as those on the left, and if the diagram be correctly drawn it will be found to close.

The following table gives the stresses on one half of the truss.

It is usual in principals of this class to introduce a vertical member connecting the apex with the centre of the horizontal tie G O. Theoretically there is no stress on this vertical, and it is not shown in the figure. The reason of its introduction is to keep the horizontal tie straight.

TABLE LXXIII.

Compressive Mem- bers,	} H A	IB	JE	KF	AB	CD	EF
Stress in Tons, .	+28·6	+26·9	+25·4	+23·8	+2·6	+5·2	+2·6
Tension Members,	A O	CO	GO	DG	FG	BC	DE
Stress in Tons, .	-24·8	-21·3	-12·6	-9·6	-13·2	-3·6	-3·6

By taking moments about *c*, we obtain—

$$S_{G O} \times 17 \cdot 3 = 10 \cdot 93 \times 35 - 3 \cdot 125 (8 \cdot 75 + 17 \cdot 5 + 26 \cdot 25),$$

$$\text{or } S_{G O} = 12 \cdot 63 \text{ tons.}$$

Several modifications of the French truss are in common use, and by the introduction of extra counterbracing, principals of this class may be used for spans up to 150 feet. The method of calculating the stresses on such structures is similar to what has already been given; no fresh difficulties arising in the construction of the stress diagrams.

224. Saw-Tooth Truss.—An example of this form of truss is shown in fig. 190, where it will be noticed that the inclination of the rafters is different. This form of truss is extensively used in weaving sheds and other factories where a steady light is required. The shorter and steeper inclination of the roof is glazed and faces the north, thereby giving a steady light; while the longer slope is usually covered with slates or tiles; these latter being supported on wrought-iron angle laths which are spaced from 8 to 14 inches apart, according to the size of the slates or tiles.

Example 12.—Determine the stresses on the truss shown in fig. 190, the span being 20 feet, and the rafters inclined at 60° and 30° . The principals are placed 11 feet apart, and the vertical load on the roof is 40 lbs. per square foot of the horizontal projection.

Total load on principal = $20 \times 11 \times 40$ lbs. = 4 tons nearly.

This load is apportioned in such a manner that 0.5 ton rests at *a*, 1.25 tons at *c*, 1.5 tons at *d*, and 0.75 ton at *b*. The

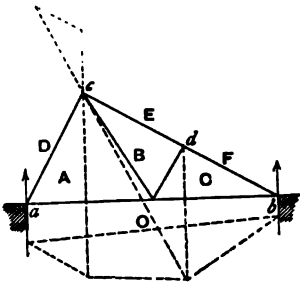

Fig. 190.

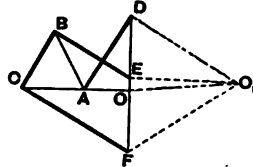

Fig. 191.

abutment reactions in trusses of this description may be most readily found by the aid of a polar diagram and funicular polygon as shown by the dotted lines.

The vertical reactions at *a* and *b* are—

DO (fig. 191) = 1.5 tons, and OF = 1.25 tons.

These reactions may be checked analytically in the usual way.

The stresses on the truss as found from the stress diagram are as follows:—

TABLE LXXIV.

Members,	DA	EB	FC	BC	AO	AB	CO
Stress in Tons,	+1.75	+1.75	+2.5	+1.25	-0.875	-1.25	-2.125

The stress on AO may be checked by taking moments about *c*; thus—

$$S_{AO} \times 8.6 = 1.5 \times 5, \text{ or } S_{AO} = 0.87 \text{ ton.}$$

The form of truss represented in fig. 192 is commonly employed at railway stations for covering island platforms. The roof is supported by two lines of columns—one at a , and the other at a_1 , upon which the truss is supported, so that the overhanging portions abc and $a_1 b_1 c_1$ are cantilevers which are connected together by the braced girder, $acc_1 a_1$.

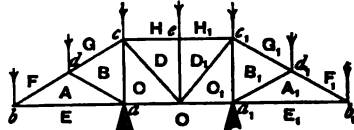

Fig. 192

Example 13.—In the truss shown in fig. 192 the distance between the columns a and a_1 is 15 feet, the overhanging portions ab and $a_1 b_1$ are also each equal to 15 feet. The rafters bc and $b_1 c_1$ are inclined to the horizontal at 30° .

Determine the stresses on the truss when two loads of 1 ton each rest at the extremities b and b_1 , and loads of 2 tons each rest on d, c, e, c_1 , and d_1 .

The vertical reactions at the points of support a and a_1 are equal to 6 tons each. In fig. 193, on a vertical line set off $EF = 1$ ton, $FG = GH = HH_1 = 2$ tons, $EO = 6$ tons, the vertical reaction at a .

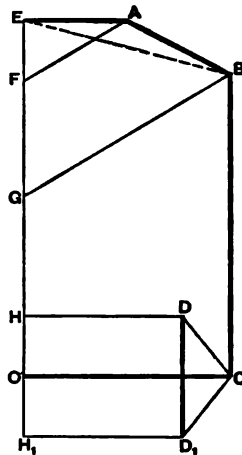

Fig. 193.

The diagram is constructed in the manner already explained.

Table LXXV. gives the stresses on the left half; those on the right half being the same.

TABLE LXXV.

Members, . .	FA	GB	HD	BC	CD	AE	CO	AB	DD ₁
Stress in Tons, .	-2.0	-4.0	-2.55	+5.0	-1.35	+1.73	+3.45	+2.0	+2.0

225. Curved Roof Trusses.—In calculating the stresses on curved trusses, the top member or bow is assumed to be made up of a series of straight lines; the portions of the curve between

two adjacent apices being considered to be straight. This assumption, as has been explained in the case of bowstring girders, has little or no effect in altering the stresses on the truss. The main ties of such trusses may be arranged in one or more straight lines. In the latter case the points of intersection of the ties usually lie in the curve of a circle which must be of larger radius than that of the top member.

Fig. 194 represents a simple form of curved truss of the ordinary bowstring pattern; the main tie-bar being horizontal. If the purlins rest on the apices *d, e, c, f, g*, it is evident that each bay, *a d, d e, e c, &c.*, will have a tendency to bend outwards from the effects of the compressive stress.

It is important, therefore, that the top member of trusses loaded in this manner be made sufficiently stiff to resist this bending action.

It is also advisable not to expose curved rafters of this description to so great a working stress as straight rafters, especially if the radius of the curve be small.

If the purlins rest at or near the centres of the different bays, this tendency to bend is to a certain extent counterbalanced by the dead weight acting through the purlin. Under such conditions, the curved member is in a more favourable condition to resist the compressive stress than is the case with straight rafters similarly loaded.

In curved roofs the wind pressure is not of equal intensity along one side, as it is in roofs with a straight slope; the slope being different at different parts of the curve,

the intensity of the wind pressure per unit of area will vary as well as its direction. To calculate the stresses arising from this force is, therefore, a tedious operation, and for all practical purposes it will

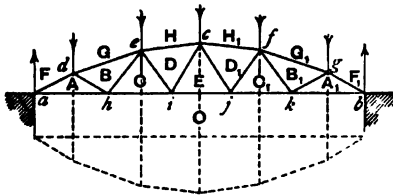

Fig. 194.

be sufficiently accurate to take the mean pressure and direction into consideration.

Example 14.—Find the stresses on the truss shown in fig. 194, the span being 55 feet and the rise 8 feet 3 inches, the top member being the curve of a circle of 50 feet radius; loads of 2 tons rest at the apices *d* and *e*, 1.5 tons at *c*, and 1 ton each at *f* and *g*.

The reactions at the abutments are most readily determined by the aid of a polar diagram and funicular polygon, as shown by the dotted lines in figs. 194 and 195.

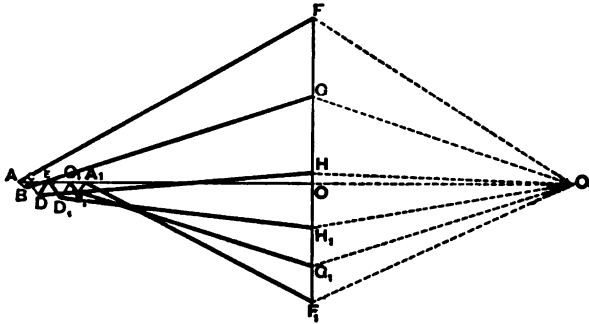

Fig. 195.

FO and F₁O (fig. 195) represent the reactions of left and right abutments, and the fig. represents the stress diagram. The following are the stresses on the truss :—

TABLE LXXVI.

Top Members,	FA	GB	HD	H ₁ D ₁	G ₁ B ₁	F ₁ A ₁		
Stress in Tons,	+8·8	+7·9	+7·25	+6·7	+6·5	+6·7		
Main Tie,	AO	CO	EO	C ₁ O	A ₁ O			
Stress in Tons,	-7·7	-7·5	-7·0	-6·3	-5·9			
Diagonals,	AB	BC	CD	DE	ED ₁	D ₁ C ₁	C ₁ B ₁	B ₁ A ₁
Stress in Tons,	-0·2	+0·1	-0·5	+0·5	+0·5	-0·5	+0·2	-0·3

By taking moments about the apex c, we get—

$$S_{H_1O} \times 8.25 = 4.3 \times 27.5 - 2(21.1 + 10), \text{ or } S_{H_1O} = 6.8 \text{ tons.}$$

This differs slightly from the stress as found by scale.

Example 15.—Fig. 196 represents a circular truss 100 feet span, the versines of the two flanges being 12 feet 6 inches and

20 feet. The points of intersection of the diagonal braces with the top and bottom flanges lie in the arcs of circles. The lengths of the panels of the top flanges are all equal to each other. Those in the bottom member are also equal to each other except the two end ones

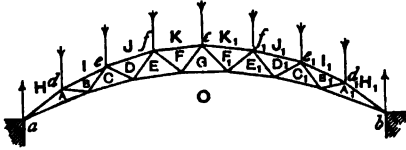

Fig. 196.

which are once and a half the length of the intermediates. Each bay is supposed to be loaded with $1\frac{1}{2}$ tons, so that a weight of $1\frac{1}{2}$ tons rests on each apex of the top member and weights of $\frac{1}{2}$ ton rest directly on the abutments.

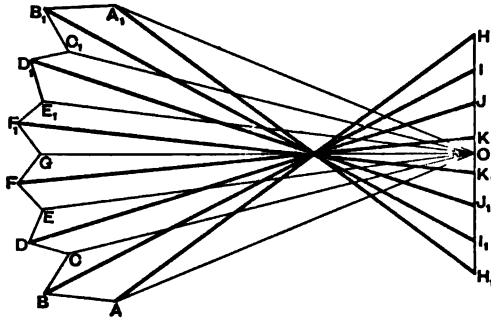

Fig. 197.

The radii of the top and bottom curves are 72.5 and 106.25 feet respectively.

The vertical reaction at each abutment = 5.25 tons.

Fig. 197 is the stress diagram. $HO = H_1O = 5.25$ tons.

The stresses for one-half the truss are given in Table LXXVII.

Taking moments about the apex we get—

$$S_{a_0} \times 7.75 = 5.25 \times 50 - 1.5 (13.75 + 26.75 + 39.0),$$

$$\text{or } S_{a_0} = 18.4 \text{ tons,}$$

which gives a check on the accuracy of the diagram.

It will be seen that in trusses of this description uniformly loaded, the stresses on all the braces are tensile, and are nearly equal to each other, with the exception of the two nearest the abutments.

Example 16.—In the last example determine the stresses on the truss if the right half be loaded with an extra ton to the bay.

In this case the loads on *d*, *e*, and *f* are 1·5 tons as before, the load on *c* = 2·0 tons, and the loads on *f*₁, *e*₁, and *d*₁ are 2·5 tons.

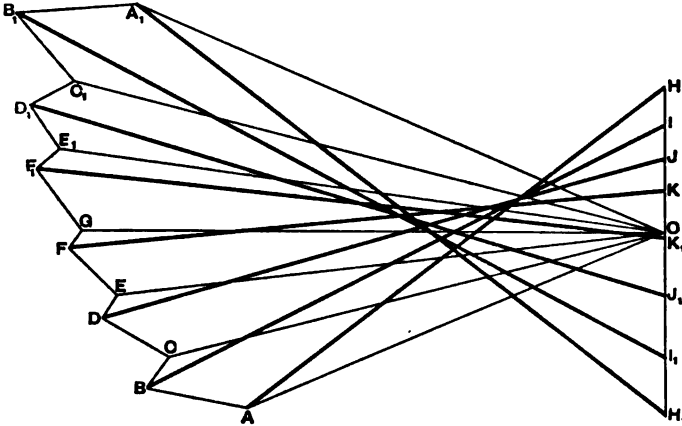

Fig. 198.

The reactions at the abutments may be found graphically by a polar diagram and funicular polygon, or else analytically by the method of moments. By either method we find abutment reactions at *a* and *b* equal to 6·2 tons and 7·8 tons respectively.

Fig. 198 is the stress diagram, where $H I = I J = J K = 1·5$ tons, $K K_1 = 2·0$ tons, $K_1 J_1 = J_1 I_1 = I_1 H_1 = 2·5$ tons.

Also $H O = 6·2$ tons and $H_1 O = 7·8$ tons, the reactions at *a* and *b*.

The stresses are given in Table LXXVIII.

By taking moments about *c* we get—

$$S_{e o} \times 7·75 = 6·2 \times 50 - 1·5 (13·75 + 26·75 + 39·0),$$

$$\text{or } S_{e o} = 24·6 \text{ tons.}$$

CHAPTER XIX.

ROOFS—*continued*.

PRACTICAL DETAILS.

226. Design of Roofs.—In proceeding to design a roof it is necessary that the designer have information on certain specific points for his guidance. In the first place the general character of the building has to be considered. The kind of roof, for example, which would be suitable for an important public building, such as a railway station, would be entirely out of place for a mill or warehouse.

A roof for a railway station should not only be designed from an utilitarian point of view, which in all cases should be the principal consideration, but also some importance should be attached to architectural appearance. This latter consideration is frequently attained by having large spans and bold outlines. Hence we find that in many important railway stations the building is covered by one large span of curved outline. A roof of this class has much to recommend it in preference to a number of smaller spans; an imposing lofty structure is obtained, and there is plenty of ventilation, and in addition there are no columns or intermediate walls to obstruct the traffic. The main objection to these large spans is that they are more expensive than a number of smaller ones of the same aggregate span.

In buildings of little architectural pretensions, such as warehouses, markets, mills, &c., it will be found more advantageous to arrange the roof in a series of small spans varying say from 20 to 80 feet. To do this it will be necessary to introduce intermediate walls or columns. These latter, instead of being an obstruction, are often useful for supporting the shafting or the gantry girders of cranes.

Roofs of from 50 to 60 feet span are, practically, the most economical, for, though in smaller spans the weight of ironwork in the framing is less in proportion to the area covered, yet this is more than counterbalanced by the extra number of columns as well as by the extra cost of covering, as there will be more ridges, gutters, and flashing, which add considerably to the cost.

227. **Loads on Roofs.**—The loads on roofs may be divided into two kinds—

1. *The Permanent or Statical Loads ;*
2. *The Accidental or Dynamical Loads.*

The Permanent loads may be subdivided into—

- (a) The weight of the Structure itself including that of the principals, purlins, intermediate rafters, and framing generally ;
- (b) The weight of the covering.

The Accidental loads comprise—

- (c) The weight of snow ;
- (d) The pressure of the wind.

We shall consider each of these separately.

(a) and (b) for any given roof are always constant from one end of the year to the other, and they always act in a vertical direction.

The weight of a principal of a certain design for a given span depends—

- (1) On the distance apart at which the principals are placed ; and
- (2) On the nature of the covering.

With the same kind of covering, and when the distance apart of the principals is constant, the weights, theoretically speaking, will vary as the squares of the spans, and in practice the actual result is not very different from this. Mr. Barlow tried to arrive at the weights of principals of different spans on this basis, and he came to the conclusion that with ordinary wrought-iron trussed principals placed 30 feet apart, when the covering consists of boarding, slating, and glass, the number of tons of iron-work in each principal is approximately equal to the square of the span multiplied by the distance apart of the principals (30 feet) and divided by 32,000.

Let S = span in feet ;

W = weight of principal in tons ;

$$W = \frac{(S)^2 \times 30}{32,000}.$$

The following table gives the weights of wrought-iron principals when placed 30 feet apart for different spans calculated on this basis :—

TABLE LXXIX.

Span in Feet.	Weight of Principal in Tons.	Span in Feet.	Weight of Principal in Tons.
80	6.0	150	21.1
100	9.4	200	37.6
120	13.5	250	58.6

The weights as determined by this rule appear to be excessive, especially in the case of the smaller spans.

It is only in roofs of large span that the weight of the framing forms the larger proportion of the total load.

The weight of the covering is usually estimated at so many pounds per square foot of ground area covered by the roof, or by so many pounds per square foot of roof surface. Approximately the framing and covering taken together will weigh about 20 lbs. per square foot.

228. Weight of Snow on Roofs.—The weight of snow which may accumulate on a roof does not often in this climate exceed 6 lbs. per square foot of the horizontal area covered by the roof, and it will be sufficient if this estimate be taken for the maximum weight. Snow which has freshly fallen is only about one-tenth the weight of water taken bulk for bulk, so that for a weight of 6 lbs. per square foot there would be nearly 12 inches average depth.

229. Wind-Pressure on Roofs.—Wind-pressure, another accidental load, is an item of great importance. In high pitched roofs, in exposed situations, the pressure from the wind may produce greater stresses on the framework than all the other loads put together. It is difficult to say what is the maximum wind-pressure per square foot of surface in this country, but it is not likely to exceed 40 lbs. distributed over a surface of considerable extent, and it is only on very rare occasions that it will reach this intensity. Greater pressures have been registered on small areas, but in dealing with roofs this need not affect the result. The full force of the wind will only be exerted on surfaces perpendicular to the direction in which it blows. Generally this direction is horizontal or nearly so; the pressure per square foot on the inclined surface of a roof will consequently be much less than 40 lbs.; its actual amount varying with the angle of inclination.

Let P_n = intensity of wind-pressure on a surface in a direction normal to it,

P_a = component of this pressure parallel to the direction of the wind,

P_p = component of the pressure perpendicular to the direction of the wind.

The following table, which is deduced from experiments made by Hutton, gives the values of P_n , P_p , and P_a in lbs. per square foot on surfaces inclined at different angles to the horizontal, the wind being supposed to blow in a horizontal direction with an intensity of 40 lbs. per square foot on a surface normal to its direction :—

TABLE LXXX.

Angle of Roof.	P_n	P_p	P_a
5°	5.0	4.9	0.4
10°	9.7	9.6	1.7
20°	18.1	17.0	6.2
30°	26.4	22.8	13.2
40°	33.3	25.5	21.4
50°	38.1	24.5	29.2
60°	40.0	20.0	34.0
70°	41.0	14.0	38.5
80°	40.4	7.0	39.8
90°	40.0	0.0	40.0

The action of wind, as affecting roofs, is greatest when it blows in a direction normal to the length of the roof, in which case it can only act on one side. It could only act on both sides simultaneously when it blew in a vertical direction, which it never does, except as a momentary gust.

When the wind blows in a direction normal to the cross-section of the roof, it has little or no effect, provided there be gable walls. If there be only gable screens the effect of the wind will be to tend to push over one principal on to the next; this tendency is counteracted by the purlins and wind bracing.

Mr. Matheson considers that a total allowance of from 3000 to 4000 lbs. per square,* for both wind and snow, is in Europe sufficient. This allowance errs rather on the side of excess, for it must be remembered that, when a high wind is blowing, any snow collected on a roof would be blown off, so that practically it is not necessary to consider *both acting at the same time*.

The French engineers in connection with the first Paris Exhibition went carefully into this question, and they allowed as little as 22 lbs. per square foot for the arched roof measured on the surface for wind and snow combined. This estimate, however, is too low for roofs of a permanent character.

It is important to bear in mind that as snow or wind may act on one side of the roof only, the strengths of the different members of the structure must be such as to meet this contingency.

Mr. Stoney says, "that for ordinary roofs in the English climate it will be sufficiently accurate if we calculate their strength on the supposition that they are liable to the following loads:—

"1st. A uniform load of 40 lbs. per square foot of ground surface, distributed over the whole roof;

"2nd. A uniform load of 40 lbs. per square foot of ground surface distributed over the weather side of the roof, and 20 lbs. on the other side which is away from the wind. This 40 lbs. will generally cover the weight of slates, boarding or laths, purlins, framing or principals, snow, and wind for roofs under 100 feet in span.

"For roofs exceeding 100 feet in span, we may assume that the total load is increased by 1 lb. per additional 10 feet—thus, the load for calculation on a 200 feet roof will be—

"1st. A uniform load of 50 lbs. per square foot of ground distributed over the whole roof;

"2nd. A uniform load of 50 lbs. per square foot of ground plan distributed over one half of the roof, and 30 lbs. on the other. When the strength of roof is calculated by the foregoing rules, the working stress in iron tie-rods may be as high as 7 tons per sq. in. of net area, unless they are welded, or unless their section is very small, in either of which cases 5 tons will be enough."

The above rules are well on the side of safety when applied to roofs with light covering under 60 feet span. For roofs of this description 35 lbs., or even 30 lbs., per square foot of area covered is frequently adopted. For a substantial design, however, 35 lbs. should be the minimum.

230. Rafters.—For light principals up to 60 feet span, the rafters usually consist of a T-bar, this being a suitable section

* A "square" of roofing consists of 100 square feet.

for transmitting a compressive stress, and also affording a simple means of attachment for the bracing bars of the truss and also for the purlins. In larger spans the rafter may be made of two angles bolted or rivetted together, or two angles and a plate between them, or two channel bars back to back, or some similar arrangement. As has been seen in Chap. XVIII., the stress at the lower portion of the rafter is greatest, and gradually diminishes towards the apex; it is not usual, however, to vary its section to suit the varying stresses, as the trouble and expense of joints and the want of uniformity more than counterbalance any advantage which may be derived from economising the material. When a joint is made, the abutting ends of the bars should be faced square so as to abut over the whole section.

231. Main Tie-Bars.—The tension members of trusses may either be round or flat bars; for the types shown in figs. 168 and 171 they are generally round, though this is not necessary. In the types shown in fig. 188, both round and flat are customary, the latter of late years becoming more common for economical reasons. Round bars have forged eyes for making the connections, and usually contain a number of welds. Flat bars may also have eyes and welds, but the more general practice is to have neither, the holes being punched or drilled cold, and the connections made with suitable joint plates. Bars with forged or swelled eyes are more economical in weight than those without, as there is as much net section at the eye as in the body of the bar. This is not the case when a hole is punched or drilled in the body of the bar, as the net section at this point is less than that of the bar by the section of the hole itself. Notwithstanding this waste, the latter plan for roofs of small span is generally found to be the more economical in cost; the extra weight being more than counterbalanced by the extra wages paid for forged work, especially in round bars. Another objection to forged work is, that it is not so reliable on account of the welds.

The advantages claimed for round tie-bars in roof-trusses are mainly on the score of appearance and fewer connections. Perhaps an additional advantage which they possess, though it is only a slight one, is that they expose a less surface, in proportion to their section, to the atmosphere, and consequently the amount of corrosion which takes place is less.

232. Struts.—Theoretically, cast iron is a suitable material for the struts of principals; in practice, however, it is found that wrought iron comes cheaper and does not add so much dead weight. Wrought iron of T-section is a favourite form of strut for trusses of the form shown in figs. 168, 171, and 173, when

the main tie-bars are round. The strut is connected to the rafter by two wrought-iron flat bars—one on each side of the web—as shown in fig. 199; the number of bolts or rivets making the connection depends on the stress coming on the strut. The foot is connected to the main tie, as shown in fig. 200, the web of the T being cut away and the back bent as shown. The vertical tie-rod passes through the strut and main tie, and the whole is fastened together by two nuts. This arrangement possesses the advantage that the vertical tie may be varied in length as may be found necessary.

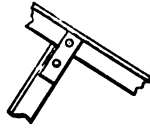

Fig. 199.

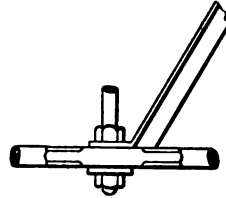

Fig. 200.

When the tension members of the truss consist of flat bars, a strut composed of two flat bars bolted or rivetted together at intervals, with cast-iron studs between to splay them out to a curve and give them stiffness, may be employed with advantage. The connection of these both to the rafter and the main tie is very simple, and they possess the manifest advantage that no smith's work is necessary.

For long struts exposed to great stress, other forms must be used. Two angle-, tee-, or channel-bars placed back to back and bolted or rivetted together at intervals make effective struts.

233. Shoes of Principals.—The connection between the main tie-bar and the foot of the rafter of a truss is called the shoe. These form the feet for supporting the truss on its bearings, and formerly were nearly always made of cast iron; now, however, they are usually made of wrought iron. Fig. 201 shows a shoe when the rafter is of tee-section; two wrought-iron bent plates are bolted to the web of the T-rafter, while the main tie-bar passes between and is bolted to them.

The connections at the crown of the principal and between two or more of the tie-bars are made in a similar manner by means of two flat plates.

When the principals rest on walls, stone pads should be placed underneath the shoes, and the latter fastened to them by Lewis bolts, which

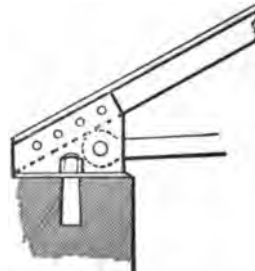

Fig. 201.

drop into holes cut in the stone, and are then run in with lead, sulphur, or some suitable cement. When the shoes rest on columns or girders they are fastened to them by ordinary bolts.

In large spans one shoe of each principal should be left free to slide on its bearing, in order to allow the principal to contract or expand freely from changes of temperature.

234. Wind-Bracing.—If the roof be not covered in at the gable end by walls, wind-bracing should be provided in order to prevent the principals being blown over in a longitudinal direction. This bracing is usually made of round or flat bars of wrought iron or steel fixed to the rafters. The attachment is made near the shoe of the first principal, and the tie is then carried in a diagonal direction, meeting the second principal at a point nearer the apex; and so on to the third and fourth. A double system of these ties should run the whole length of the roof.

If the roof-covering be of corrugated iron, wind-bracings are not necessary as the covering itself answers the same purpose.

A longitudinal wrought-iron tie-bar running the full length of the roof and connecting the centres of the main tie-bars with one another is frequently introduced.

This helps to prevent any oscillations of the bracings of the trusses, and is specially of use in roofs liable to vibrations from the working of machinery.

235. Roof Trusses with Curved Rafters.—Trusses with curved rafters may be used in all spans however small; with spans over 100 feet they almost become a necessity. The struts required for bracing trusses of large span with straight rafters must of necessity be long, and consequently require a good deal of stiffening, which renders them expensive. In a curved truss, the bracings are not exposed to great stresses, and in the majority of cases these are tensile. For this reason the intermediate bracings of large trusses with curved rafters are much simpler and lighter than those in trusses with straight rafters.

236. Arched Ribs.—Braced arched ribs are used for roofs of the largest spans and may be classed under two heads—

1. Those having solid plate webs;
2. Those having open or braced webs.

The abutments upon which an arched rib rests must be of suitable strength and stability in order to resist the outward thrust of the arch. Frequently the arch is continued down to the ground and securely anchored to suitable foundations. In designing an arch of wrought iron or steel, it is not necessary for stability that the line of pressures should fall within it (see

Chap. XVII.), as from the nature of these materials, they are capable of resisting transverse stresses.

The direction of the line of pressures is fixed with considerable exactness when the arch is hinged at the crown and also at the bearings, and it is advisable that this be done in very large spans. The largest single span ever made, was that for the roof constructed over the machinery hall at the Paris Exhibition of 1889. The clear span of this roof is 377 feet, and the ribs are made of steel, hinged both at their bearings, which are at the ground level, and also at the crown. These hinges or pivots, in addition to directing the line of pressures, enable the arch to accommodate itself to changes of temperature.

When a roof consists of two or more adjacent spans of the arched form, the intermediate bearings may be supported on columns without any danger of these being tilted over by an outward push, as the thrust of one arch is counterbalanced by that of the adjacent one; but in all cases the outside abutments must be of substantial form when the arch is not carried down to the ground level. The cross-section of wrought-iron or steel arched ribs of small span, usually consists of four angle-bars rivetted to a web, the latter being either a continuous plate or a series of lattice bars. For larger spans the section may be of the box form and much more complex in design. With an open braced web consisting of diagonals and radiating struts, the diagonals need be designed to transmit a tensile stress only, the compressive stress on the web being transmitted by the radiating struts. If a lattice or warren system be used, all the diagonals should be designed to act as struts as well as ties, so as to meet the varying stresses produced in the web by wind-pressure.

When the depth of the arch at the crown is considerable in proportion to the span, it becomes a braced arch of a peculiar shape, and may be designed so as to exert no outward pressure on the supports. Arches of this kind are used in the construction of the roof of the Crystal Palace at Sydenham.

237. Distance apart of the Principals.—The distance apart at which the main ribs or principals of a roof should be placed depends on a variety of considerations, and is a question upon which the engineer should use his judgment in each particular case. As a rule, the larger the span, the further apart should be the principals; but there is no rule by which the relationship can be fixed.

In roofs of small span, say from 40 to 100 feet, this distance usually varies from 7 to 20 feet; if the distance be further than

this, it is usual to introduce one or more intermediate rafters. The nature of the covering on a roof has a good deal to do in determining the most economical spacing of the principals. In a roof which is to be covered with slates or tiles supported on iron purlins, or on boarding, it is most economical to fix the distance from 6 to 10 feet, or, if further than this, intermediate rafters should be introduced.

When the principals are 20 feet apart and upwards, it is usual to connect them together by means of lattice girders, which act as purlins. These girders support one or more intermediate rafters, which should be fixed at the same level as the main rafters. Several purlins are fixed to the backs of the rafters at certain distances apart, dependent on the kind of covering on the roof.

238. Working Stresses on Roof Trusses.—The maximum working stress which should be allowed to come on the main rafters and struts of a roof-truss, depends on the manner in which they are stiffened; and, generally speaking, for wrought iron it varies between $2\frac{1}{2}$ and 4 tons per square inch of the gross section, the higher stress in no case being exceeded.

The amount of stress allowed on the tension bracings depends upon whether they are welded or not. In flat tie-bars which are not welded, the working stress may be as high as 6 tons per square inch of net sectional area. With welded round bars the stress should never exceed 5 tons, but it is better not to allow more than $4\frac{1}{2}$ tons or, in bars exceeding 3 inches in diameter, not more than 4 tons. Even with these diminished stresses, unless extra precautions be taken, a welded bar is not nearly so reliable as an unwelded bar exposed to 6 tons. When the material is mild steel the above stresses may be increased from 30 to 50 per cent.

In roof-work generally it is much better to drill than to punch the bars. Drilling, however, is much more expensive, and is the exception rather than the rule, except when the material is steel, when the engineer usually insists on drilled work.

ROOF COVERINGS.

239. Different kinds of Roof Coverings.—The most common materials used for roof coverings are *Slates, Tiles, Corrugated Iron, Copper, Lead, Zinc, Felt, Glass, &c.*

The following table gives the weight per square foot of the different coverings and the minimum angle at which they should be laid :—

TABLE LXXXI.—WEIGHTS OF ROOFING MATERIALS AND
MINIMUM SLOPE.

KIND OF COVERING.	Weight per sq. ft. in lbs.	Minimum slope.
Slates,	6·0 to 10·0	22½° to 30°
Tiles,	6·5 to 17·8	22½° to 30°
Sheet-iron, plain, ⅜ inch thick, . . .	3·0	4°
„ corrugated, 20 to 16 B.W.G., . . .	2·5 to 4·0	4°
Sheet copper, about ·022 inch thick, . .	1·0	4°
Sheet lead,	6·0 to 8·0	4°
Sheet zinc, 13 to 16 zinc gauge, . . .	1·5 to 2·0	4°
Boarding, ¾ inch thick,	2·5	22½°
Timber framing for slates or tiles, . . .	5·0 to 6·5	...
¼-in. glass, exclusive of sash-bars or framing,	3·5	...

240. Slates.—The most common covering for roofs in this country is slates; in fact, it is no exaggeration to say that slates are more used in England than all other coverings put together. They are very durable, not being attacked by moisture, smoke, or the various atmospheric impurities that are so common in large towns. When no boarding is used, the usual plan, in iron roofs, is to fix the slates to wrought-iron angle-laths or purlins, which are bolted to the rafter backs of the principals. These laths are fixed about 10½ inches apart, and run longitudinally with the roof. When the principals are from 6 to 8 feet apart, the size of the laths should be about 1½ inches × 1½ inches × ¼ inch; when they are from 8 to 10 feet apart, a stronger section should be used, say 2 inches × 2 inches × ⅝ inch.

The slates may rest directly on the laths and be fixed to them by copper wire passing through the slate, its ends being twisted together underneath the lath; or, as is frequently the case, a timber batten is fixed to the lath by means of screws, and the slates are fixed to the batten by nails; this arrangement is shown in fig. 202.

Zinc or copper nails are better than iron ones, the latter being liable to oxidation.

Instead of using iron laths for supporting the slates, a layer of timber boarding, tongued and grooved, may be fixed to the rafters; the slates are then laid on the boarding and fixed by nails. This arrangement, though more expensive, has the advantage of keeping the building warmer in winter and cooler in summer. For principals 8 feet apart $1\frac{1}{4}$ -inch boarding should be used, and it is best to have it run diagonally with the rafters.

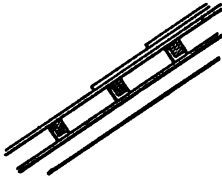

Fig. 202.

The minimum angle at which slates should be laid ought not to be less than 25° with the horizontal; when flatter the rain is liable to be blown through the joints. No matter at what angle slates are laid, the wind will penetrate through the crevices, even when the joints are covered with mortar, unless boarding is used.

241. Tiles.—Tiles are a very old form of covering for roofs, though not used to anything like the same extent as slates in this country. They are more common in other countries, and on account of their great weight are peculiarly adapted to countries where hurricanes occur. The method of fixing them is similar to that employed for slates, though a stronger framing is necessary on account of their extra weight.

Pantiles are a light form of tile, and are manufactured in France and Holland to a large extent. They are constructed specially with the object of laying them on angle or tee-laths placed about 12 inches apart, each tile having a small projecting lip which catches behind the lath, and the weight of the tiles as they overlap keeps each in its place. As an extra precaution against wind, it is advisable to tie each tile to the purlin by a copper wire which passes through a hole in the tile made specially for the purpose.

The effective width of these pantiles, exclusive of lapping, is 8 inches, and 105 tiles go to make a square. Each tile when dry weighs between 5 and 6 lbs. Ten per cent., however, should be added to this weight for the moisture which they absorb.

242. Corrugated Iron.—Corrugated iron sheets, either plain or galvanised, form a very common covering for certain classes of roofs. The framing in such case must be arranged so as to utilise the bearing power of the sheets. The sheets may be laid in two ways, either with the flutes running down the slope of

the roof, or else running horizontally. In the former case, which is the most common, the sheets rest directly on the purlins; these latter may be placed from 6 to 12 feet apart according to the thickness of the sheets and the depth of the flutes. Bent corrugated sheets are so stiff that they are sometimes used for small spans without any supporting framework, it being only necessary to tie the eaves together by a wrought-iron horizontal bar; a horizontal angle-bar or a gutter being attached to the eaves to give stiffness. Roofs of spans up to 40 feet, and even more, have been made in this way, but of course they are not durable and are only erected for temporary purposes. It is a common thing, however, to erect permanent roofs of this kind with an extremely light framework.

When the flutes of the sheeting run horizontally, no purlins are required, the sheets resting directly on the rafters, which latter may be from 6 to 12 feet apart, according to the strength of the sheets. When the sheets are laid in this way a special kind of corrugation should be used so as to allow a drop for the rain water.

Corrugated iron sheets, as used for roofs, are generally galvanised, or covered with a layer of zinc, by dipping them in a zinc-bath. This is done with the object of preserving the sheets from oxidation by the atmosphere. It is the usual practice to galvanise the sheets before corrugating them, but in the case of thick sheets it is best to reverse the process and have the galvanising done last. By this latter method any cracks which may be developed in the stamping process get filled up with the zinc, and the sheets will be more perfect.

A good deal of diversity of opinion exists among engineers as to the value of this covering for roofs. Many instances have been known where the galvanising has little or no effect in preserving the sheets. In fact, where flaws do occur in the zinc coating, sheets have been known to deteriorate more rapidly at these parts than if they had not been galvanised at all. Their durability depends on the quality of the sheets and also on the kind of atmosphere which surrounds them. The quality of the sheets depends on the quality and the thickness of the iron from which they are made, and also on the care taken in coating them. If the sheets be not made of good iron, well rolled, and free from imperfections, they will not hold the zinc coating properly. Any spots on the sheets not properly covered, when exposed to the weather, oxidise very rapidly, and the sheets at such points soon become destroyed. Again, in the process of stamping, if the iron be not ductile, cracks are formed, and though these cracks

may be very minute, still on exposure to the atmosphere oxidation rapidly sets in and the whole sheet becomes worthless. The bad repute into which galvanised sheets have of late years fallen, is due to a large extent to inferior material and workmanship.

Atmospheric conditions have a great deal to do with the life of galvanised sheets. In a pure atmosphere good sheets last a long time and prove an economical covering, but in the neighbourhood of large manufacturing towns where the air is impregnated with sulphurous and other gases, their life is much shorter. In gas-works they should never be used. If the sheets be cleaned and painted from time to time, their life is very much prolonged. In the neighbourhood of large towns it is best to use ungalvanised sheets, and to clean and paint them periodically; good paint seems to possess more preservative properties against the attacks of oxidation than does galvanising.

The thickness of corrugated sheets is measured by their *gauge*, and the letters B.W.G. or I.W.G., which mean Birmingham wire gauge and Imperial wire gauge respectively, with the number attached, give the thickness.

The following table gives the different gauges with their equivalent in inches and the weights per square.

TABLE LXXXII.—CORRUGATED IRON ROOF COVERING.

B.W.G.	Equivalent in Inches.	Size of Flutes.	Approx. Weight per Square.
16	·065	5 Inches	340 Lbs.
17	·056	5 „	310 „
18	·049	5 „	280 „
19	·042	5 „	252 „
20	·035	5 „	224 „
21	·032	3 „	205 „
22	·028	3 „	185 „
23	·025	3 „	167 „
24	·022	3 „	150 „

The square here given represents a square of the sheets as laid. Of course there is actually more than 100 square feet of sheets in the square of roof covering, the excess, which represents the amount of lappage varying from 8 to 15 per cent.

The distance P (fig. 203) represents the width of the flute, and d the depth. The width and depth of the flutes may be varied at pleasure. The most usual widths in this country are 3, 4, and 5 inches, and the depth is about one-fourth of the width. The deeper, the flute, the stronger will be the sheet to resist transverse stress, and the farther apart may the purlins be placed.

The following rule has been given for determining the transverse strength of sheets :—

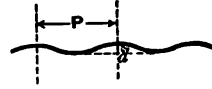

Fig. 203.

l = unsupported length of plate in inches.

t = thickness of plate in inches.

b = breadth of plate in inches.

d = depth of corrugations in inches.

W = breaking weight distributed in tons.

$$W = \frac{44 \cdot 6 \ t \ b \ d}{l} \quad . \quad . \quad . \quad (1).$$

The most usual gauges used in England are Nos. 16 to 22 B.W.G. Anything thinner than 22 B.W.G. does not possess a long life, and should only be used for temporary purposes. Large quantities of the thinner sheets, however, are exported. No. 16 is only used in exceptional cases where great strength and durability are required. No. 18 is used for first-class work generally.

According to Mr. Matheson, to whom I am indebted for a great deal of information on this subject, "Sheets of No. 16 with flutes 10 by 2½ inches may be laid on purlins 15 feet apart, while sheets of similar thickness with 5-inch flutes require purlins not more than 10 feet apart." But although the sheets may carry these distances it is not usual in practice to place the purlins so far apart; for 5-inch flutes they are generally placed from 6 to 8 feet.

The ordinary sizes of corrugated sheets are from 5 to 8 feet long, and from 2 to 3 feet wide; the number of square feet in a

single plate not exceeding 20. The sheets when laid, overlap each other to the extent of from 3 to 4 inches along their narrow edges, and about 2½ inches along the flutes or long edges; the flatter the roof, the greater being the lap at the ends. The sheets are joined together by means of bolts, which should always pass through the ridge of the corrugation, and not through the hollow or trough; this is done to prevent water percolating through the hole. Washers of felt or some other material are placed underneath the nut with the same object.

The holes in the sheets may be easily punched by hand during erection. The sheets are first tried in their places so that the exact position of the holes can be got; by this means blind holes are avoided. The sheets are usually attached to the framing by means of hook bolts, which pass round the purlin, the nut being placed on the outside of the sheets. When the sheets rest on wood purlins, or on iron purlins with wood scantlings, they should be fixed by means of spikes or screws from 2 to 3 inches long; all the spikes, bolts, screws, or other fastenings being galvanised.

When sheets are sent abroad, it is customary to have the holes along one side and one end of each sheet punched before leaving the works, the remaining holes being marked off and punched during erection. By doing this the amount of labour required in the erection is minimised.

The ridge of a corrugated iron roof may be covered by the same material, which is bent over and bolted to the sheets at each side of the slope. A half-round gutter made of plain wrought iron makes a convenient and cheap gutter for this covering, it being supported by wrought-iron semicircular brackets made of flat bars bolted at intervals to the sheeting.

When corrugated sheets are worn out they possess little or no value as old material, being unlike lead, copper, or zinc in this respect.

243. Zinc.—Zinc, as a covering for roofs, is not much used in England, though of late years its use has been gradually extending. In France and other continental countries it is much more extensively employed.

The gauge by which zinc is measured is different from the B.W.G. of corrugated sheeting. The following table gives some of the gauges with their equivalents in B.W.G. and the weights per square foot:—

TABLE LXXXIII.—ZINC SHEETS.

B.W.G.	Zinc Gauge.	Weight per square foot in lbs.
21	13	1·22
20	14	1·35
19	15	1·49
18	16	1·62

These weights are for perfectly plain sheeting without corrugations.

A covering of zinc is very much better adapted to resist the attacks of the weather and a vitiated atmosphere than galvanised iron. It is liable to oxidation, but the oxide so formed is not liable to scale off like the zinc oxide on galvanised iron; on the contrary it forms a permanent coating on the surface which renders the metal proof against atmospheric action, so that the use of paint is wholly unnecessary.

Zinc sheets are usually made in lengths of 7 or 8 feet and about 3 feet wide; when larger, an extra charge is made.

The expansion and contraction of zinc for changes of temperature are much greater than those of iron, and for this reason plenty of play should be given to the laps in laying the sheets.

Gauge No. 13 should only be used for temporary covering and to save first cost. Gauges Nos. 14 and 15 should be used for good work.

There are several methods of laying zinc covering on roofs, of which the following are the most common :—

1. Ordinary corrugation,
2. Plain roll cap,
3. Drawn roll cap,
4. Italian corrugation.

Ordinary corrugation is principally used in curved roofs and for side enclosures. In the plain roll cap, or French plan, the sheets are laid on boarding with wood rolls.

The following table gives the approximate weights per square for the different methods and for different gauges, including all corrugations and laps :—

TABLE LXXXIV.—WEIGHTS PER SQUARE OF ZINC COVERING.*

No. of Gauge.	13	14	15	16
1. Ordinary Corrugations,	160 lbs.	185 lbs.	200 lbs.	220 lbs.
2. Plain Roll Cap, .	160 ,,	180 ,,	195 ,,	215 ,,
3. Drawn Roll Cap, .	165 ,,	185 ,,	200 ,,	220 ,,
4. Italian Corrugations, .	160 ,,	185 ,,	200 ,,	220 ,,

244. Lead Covering.—Lead sheets are laid upon rolls somewhat in the same manner as zinc sheets, but with close boarding underneath. Lead, as used for roofs, is first cast into small sheets, and then rolled out to the size and thickness required. The different thicknesses of the sheets are known by their weight per square foot; thus we have 4 lbs. lead, 6 lbs. lead, 8 lbs. lead, and so on, a square foot weighing 4 lbs., 6 lbs., and 8 lbs. respectively. A square foot of lead $\frac{1}{8}$ inch in thickness weighs about $7\frac{1}{4}$ lbs. The strength of lead sheets usual for roof coverings is 6 lbs. and 8 lbs., and for flashings 5 lbs. and 6 lbs. Lead covering is more expensive than zinc, but it lasts much longer.

245. Felt Covering.—Felt is a cheap form of roof-covering, and may be easily renewed from time to time, it being laid on boarding. Each roll of felt for roofing purposes contains about 25 yards, 32 inches wide, and about $\frac{1}{8}$ inch in thickness. It is made from hair, wool, or vegetable fibre by compressing and saturating these materials with asphalt, bitumen, or ordinary tar. Good felt is impervious to rain or snow, and will last a considerable time under most conditions of climate. For good permanent roofs it is only used as an inner lining; the outer covering being slates, corrugated iron, or zinc.

246. Glass.—Nearly all roofs of large structures contain glass as part of their covering, and in some cases it forms the entire covering. The glass usually runs in widths longitudinally with the roof, and joins on at its sides to the other covering.

The old-fashioned, and perhaps the best, method of glazing is with timber sash-bars and putty. The sash-bars, which may be made of wood or iron, are usually placed from 12 to 20 inches apart, and supported at intervals of from 6 to 8 feet. It is easier to make the covering water-tight by using wood sash-bars; those made of iron do not expand and contract equally with the glass, and consequently the putty is liable to get cracked, thereby

* Matheson—*Works in Iron*, p. 212.

allowing the water to percolate through. When made of wrought iron, the sash-bars may be ordinary bars of T-section from 1 to 2 inches deep and from $1\frac{1}{2}$ to 2 inches across the flange. A very useful form is that shown in section in fig. 204; the upper flange forms a good protection for the putty. Cast iron is sometimes used either in single bars or in the form of a frame.



Fig. 204.

Several varieties of glass are used for glazing purposes. When a good deal of light is required it should be clear and transparent; but for ordinary roofs, such as those that cover warehouses and railway stations, a much coarser kind is employed.

The width of glass sheets for this purpose varies between 12 and 20 inches, and they are made in lengths up to 6 feet, the thickness varying between $\frac{1}{8}$ and $\frac{1}{4}$ inch. What is known as "patent rolled rough plate" is most suitable for roofs.

The price of glass varies with the thickness. Panes of ordinary size $\frac{1}{8}$ inch thick cost about threepence per square foot, and those $\frac{1}{4}$ inch about fivepence; the fluted varieties being about three halfpence per foot more. Glazing costs from a penny to two-pence per square foot, depending on the height from the ground and other circumstances.

247. Ventilation of Buildings.—The usual method of ventilating a building through the roof is by means of a lantern or similar contrivance. A lantern may run the whole length of the roof or extend only over a portion of it. It is formed by raising the covering at the ridge for a certain width; a space is thus created at each side of the ridge, which allows the egress and ingress of air. In order to prevent rain or snow being driven through the ventilating openings, louvre blades are fixed to upright standards, called louvre standards; these blades, which are usually made of wood, are arranged at an angle, one lapping over another, so that, while allowing a free passage for air, they prevent rain being blown through. With fixed louvre blades it is impossible to prevent snow being blown in; this difficulty may be got over by arranging the blades so that they may revolve on a horizontal axis, they can thus be opened or closed at will. The blades are sometimes made of iron, zinc, glass, &c., as well as wood. In roofs of large span and where a great deal of ventilation is necessary, such as in railway stations, it is advisable to have similar ventilating openings down the sides of the roof as well as at the ridge.

248. Timber Roofs.—There is not the same objection to timber roofs that there is to timber bridges. They are better protected from the weather, and are consequently more durable, and for small spans they are not likely to be superseded by iron roofs.

The following tables* give the size of the scantlings generally used for the different spans named; the covering being slates, and the timber Baltic pine, or other equally strong:—

TABLE LXXXV.—SCANTLINGS OF TIMBER FOR DIFFERENT SPANS FROM 20 TO 30 FEET; THE TRUSSES BEING 10 FEET APART.

The form of truss is shown in skeleton outline in fig. 168.

Span.	Tie-Beam.	King Post.	Principal Rafters.	Struts.	Purlins.	Small Rafters.
Feet.	Inches.	Inches.	Inches.	Inches.	Inches.	Inches.
20	9½ × 4	4 × 3	4 × 4	3½ × 2	8 × 4½	3½ × 2
22	9½ × 5	5 × 3	5 × 3	3½ × 2½	8½ × 5	3½ × 2
24	10½ × 5	5 × 3½	5 × 3½	4 × 2½	8½ × 5	4 × 2
26	11½ × 5	5 × 4	5 × 4½	4½ × 2½	8½ × 5	4½ × 2
28	11½ × 6	6 × 4	6 × 3½	4½ × 2¾	8¾ × 5½	4½ × 2
30	12½ × 6	6 × 4½	6 × 4	4¾ × 3	9 × 5½	4¾ × 2

TABLE LXXXVI.—SCANTLINGS FOR ROOFS FROM 30 TO 46 FEET SPAN. TRUSSES 10 FEET APART.

Form of truss as shown in skeleton outline in fig. 175.

Span.	Tie-Beam.	Queen Posts.	Principal Rafters.	King Post.	Braces.	Purlins.	Small Rafters.
Feet.	Inches.	Inches.	Inches.	Inches.	Inches.	Inches.	Inches.
32	10 × 4½	4½ × 4	5 × 4½	6¾ × 4½	3¾ × 2½	8 × 4¾	3½ × 2
34	10 × 5	5 × 3½	5 × 5	6¾ × 5	4 × 2½	8½ × 5	3¾ × 2
36	10½ × 5	5 × 4	5 × 5½	7 × 5	4½ × 2½	8½ × 5	4 × 2
38	10 × 6	6 × 3¾	6 × 6	7½ × 6	4½ × 2½	8½ × 5	4 × 2
40	11 × 6	6 × 4	6 × 6	8 × 6	4½ × 2½	8¾ × 5	4½ × 2
42	11½ × 6	6 × 4½	6½ × 6	8½ × 6	4½ × 2¾	8¾ × 5½	4½ × 2
44	12 × 6	6 × 5	6½ × 6	8½ × 6	4½ × 3	9 × 5	4¾ × 2
46	12½ × 6	6 × 5½	7 × 6	9 × 6	4¾ × 3	9 × 5½	5 × 2

* Spon's Dictionary of Engineering, Division viii.

TABLE LXXXVII.—SCANTLINGS FOR ROOFS FROM 46 TO 60 FEET SPAN.
TRUSSES 10 FEET APART.

These trusses have a horizontal straining-beam between apex and tie-beam.

Span.	Tie-Beam.	Queen Posts.	Posts.	Principal Rafters.	Straining Beam.	Braces.	Purlins.	Small Rafters.
Feet.	Inches.	Inches.	Inches.	Inches.	Inches.	Inches.	Inches.	Inches.
48	11½ × 6	6 × 5½	6 × 2¼	7½ × 6	8¼ × 6	4½ × 2½	8¼ × 5	4 × 2
50	12 × 6	6 × 6¼	6 × 2¼	8½ × 6	8½ × 6	4½ × 2½	8½ × 5	4½ × 2
52	12 × 6½	6 × 6¾	6 × 2½	9¼ × 6	8¾ × 6	4¾ × 2¾	8¾ × 5½	4½ × 2
54	12 × 7	7 × 6¾	7 × 2¼	6½ × 7	9 × 6	5½ × 2½	8¾ × 5½	4½ × 2
56	12 × 8	7 × 6¾	7 × 2½	7½ × 7	9½ × 6	5 × 2¾	8¾ × 5½	4½ × 2
58	12 × 8½	7 × 7¼	7 × 2¾	8¼ × 7	9½ × 7	5 × 2¾	9 × 5½	4¾ × 2
60	12 × 9	7½ × 7	7 × 3	9 × 7	10 × 7	5 × 3	9 × 5½	4¾ × 2

CHAPTER XX.

DEFLECTION OF GIRDERS—CAMBER OF GIRDERS.

249. **Causes which Influence the Deflection of Girders.**—When a girder is loaded it becomes deflected, or cambered in a downward direction. If the limit of elasticity of the metal be not exceeded, the girder will practically regain its original form when the load is removed; when this limit is exceeded the girder becomes permanently deflected, or takes what is known as a permanent set.

It is possible to calculate beforehand what will be the deflection of a girder with a given load.

The amount of the deflection depends mainly on the following:—

1. The length and depth of the girder;
2. The stress per unit of area on the flanges.

The deflection arises from the top flange being compressed or shortened, and the bottom flange extended. In scientifically

constructed girders the sectional areas of the flanges at different sections are in proportion to the stresses at these sections, so that the unit stress on each flange is uniform throughout its length. The amount of deflection is practically independent of any change of form which may take place in the web, and is not affected by the kind of web; a continuous plate and a lattice web giving similar results under similar conditions of loading.

When a girder is loaded, the unit flange-stress may be determined; and knowing this, and also the modulus of elasticity of the material, the amount of compression in the top flange and of extension in the bottom flange may be calculated. Having determined these changes of length, the deflection may be found by means of a simple equation, which we will now investigate.

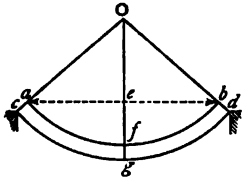

Fig. 205.

250. Rules for finding the amount of Deflection.—Fig. 205 represents a girder supported at its extremities and loaded;

when the unit stress is constant throughout the entire length of each flange, the curve of deflection will be the arc of a circle.

- Let O represent the centre of the circle,
- $a f b = l =$ length of top flange,
- $c g d = l_1 =$ length of bottom flange,
- $e f = D =$ the central deflection,
- $f g = d =$ depth of the girder,
- $O a = r =$ radius of curvature of the top flange.

Since in loaded girders the deflection is small compared with the radius, $O e$ may be taken equal to r ; also $a e b$ is nearly equal to l . Making these substitutions, we get (*Euc.*, Book III., prop. 35)—

$$2 r \times D = \frac{l^2}{4}, \text{ or } D = \frac{l^2}{8 r} \quad . \quad . \quad . \quad (1).$$

By similar triangles, we get—

$$\frac{r}{r + d} = \frac{l}{l_1}, \text{ or } r = \frac{d l}{l_1 - l} \quad . \quad . \quad . \quad (2).$$

Substituting this value of r in equation (1) we get—

$$D = \frac{l(l_1 - l)}{8 d} \quad . \quad . \quad . \quad (3).$$

Equation (3) is a convenient formula for calculating the deflection when the contraction and expansion of the flanges are known.

This contraction and expansion may be determined thus—

Let f = stress on the flanges in tons per square inch,
 E = modulus of elasticity of the material in tons.

Then, as the length of the top flange is shortened by $\frac{l_1 - l}{2}$, we get—

$$\frac{f}{E} = \frac{l_1 - l}{2l}, \text{ or } l_1 - l = \frac{2fl}{E} \quad . \quad . \quad . \quad (4).$$

Substituting this value of $l_1 - l$ in equation (3), we obtain—

$$D = \frac{fl^2}{4dE} \quad . \quad . \quad . \quad (5).$$

D , l , and d being expressed in inches.

If l and d be expressed in feet, we get—

$$D = \frac{3f l^2}{dE} \quad . \quad . \quad . \quad (6).$$

Example 1.—A steel girder, 150 feet span and 12 feet deep, is loaded with $1\frac{1}{4}$ tons per foot, including its own weight. If the net sectional area of each flange at the centre be 42 square inches, what will be the deflection of the girder?

Distributed load on girder = $150 \times 1\frac{1}{4} = 187.5$ tons.

Flange stress at centre = $\frac{187.5 \times 150}{8 \times 12} = 293$ tons.

Stress per square inch } = $\frac{293}{42} = 7$ tons nearly.
 on metal in flange

We have, then, the following—

$f = 7, \quad l = 150, \quad d = 12, \quad E = 13,000.$

Substituting these values in equation (6), we get—

$$D = \frac{3 \times 7 \times (150)^2}{12 \times 13,000} = 3.03 \text{ inches.}$$

If the depth of the above girder be 10 feet, the deflection will be 3.63 inches.

If the values of f for the top and bottom flanges be different, the mean of the two should be taken.

By transposing the members in equation (6) we get—

$$f = \frac{D \cdot E}{3 l^2} \quad . \quad . \quad . \quad (7).$$

This equation will enable us to find the flange stresses in a girder when its deflection is known.

Example 2.—In testing the wrought-iron main girders of a railway bridge they were found to deflect 1·9 inches at the centre. The girders were of uniform strength, 126 feet span and 10 feet 6 inches deep. What were the flange stresses developed in the girders?

From equation (7), we get—

$$f = \frac{1\cdot9 \times 10\cdot5 \times 11,600}{3 \times (126)^2} = 4\cdot86 \text{ tons.}$$

This will represent the mean stress per square inch on the flanges; if the top and bottom flanges are of unequal sectional area, the stress on each will be inversely proportional to its area.

The usual deflection allowed for in girders under ordinary loading varies from $\frac{1}{1200}$ th to $\frac{1}{800}$ th part of the span; under special circumstances it may reach three or four times this amount.

For the proof loads on bridges Rankine gives the deflection from $\frac{1}{200}$ th to $\frac{1}{800}$ th part of the span; this, however, is rather excessive. American engineers allow a deflection of $\frac{1}{1200}$ th after the girder has taken its permanent set.

251. Deflection of Solid Beams.—The calculation of the deflection of solid beams is a more difficult matter than that of flanged girders, as it depends on the moment of inertia of their cross-section.

For a girder loaded with a central weight W

$$D = \frac{W l^3}{48 E I} \quad . \quad . \quad . \quad (8).$$

For a girder loaded with a distributed weight W

$$D = \frac{5 W l^3}{384 E I} \quad . \quad . \quad . \quad (9).$$

For a semi-girder loaded at the extremity with a weight W

$$D = \frac{W l^3}{3 E I} \quad . \quad . \quad . \quad (10).$$

For a semi-girder loaded with a distributed weight W .

$$D = \frac{W l^3}{8 E I} \quad . \quad . \quad . \quad (11).$$

The beam in all these cases is supposed to be of uniform section throughout.

The above formulæ may be adapted to beams of various sections by substituting in each equation the proper value of I .

Thus, for a rectangular beam of width b and depth d , $I = \frac{b d^3}{12}$, and substituting this in the above equations, we get—

$$D = \frac{W l^3}{4 E b d^3} \quad . \quad . \quad . \quad (12)$$

for rectangular beams loaded at the centre.

$$D = \frac{5 W l^3}{32 E b d^3} \quad . \quad . \quad . \quad (13)$$

for rectangular beams uniformly loaded.

$$D = \frac{4 W l^3}{E b d^3} \quad . \quad . \quad . \quad (14)$$

for cantilevers loaded at the end.

$$D = \frac{3 W l^3}{2 E b d^3} \quad . \quad . \quad . \quad (15)$$

for cantilevers uniformly loaded.

For a circular surface of radius r , $I = \frac{\pi r^4}{4}$. Substituting in equations (8), (9), (10), and (11), we get—

$$D = \frac{W l^3}{12 E \pi r^4} \text{ for circular beams loaded at the centre,}$$

$$D = \frac{5 W l^3}{96 E \pi r^4} \text{ for circular beams uniformly loaded,}$$

$$D = \frac{4}{3} \frac{W l^3}{E \pi r^4} \text{ for cantilever beams loaded at the end,}$$

$$D = \frac{W l^3}{2 E \pi r^4} \text{ for cantilever beams uniformly loaded.}$$

Example 3.—A square beam of oak 6 inches \times 6 inches rests on two supports 20 feet apart. What will be its central deflection, with a central load of 1 ton, the modulus of elasticity of the oak being 760 tons?

$$W = 1 \text{ ton, } l = 240 \text{ inches, } b = d = 6 \text{ inches, } E = 760 \text{ tons.}$$

Substituting these values in equation (12), we find—

$$D = \frac{(240)^3}{4 \times 760 \times (6)^4} = 3.5 \text{ inches.}$$

Example 4.—In a beam of beech similar to the last and similarly loaded, the deflection was found to be 4 inches. What is the modulus of elasticity of the beech?

By transposing equation (12), we get—

$$E = \frac{W l^3}{4 D b d^3}$$

By substitution—

$$E = \frac{(240)^3}{4 \times 4 \times (6)^4} = 666 \text{ tons.}$$

CAMBER IN GIRDEES.

252. Amount of Camber in Girders.—It is usual to build girders so that the flanges have an initial curve in an upward direction; this curve is usually termed the *camber* of the girder, and the amount of camber is measured by the rise of the central point of the flange above the straight line joining its extremities. The amount of camber that it is usual to put in a girder varies with its length, and, roughly speaking, is about 1 inch for every 40 feet of length, so that a girder of 120 feet span would have, before loading, a rise of about 3 inches at its centre.

The cambering of a girder does not add to its strength, it being chiefly introduced for the sake of appearance; girders whose flanges slightly curve in an upward direction looking much better

than those which curve downwards. It is not usual to camber the full length of the bottom flange; the portions which rest on the abutments being made straight.

253. **Methods of finding the Ordinates of the Curve.**—The curves of the top and bottom flanges are circular, and have a common centre; and knowing the span and the rise at the centre, the radii of these curves may be found as follows:—

Let the chord $a b$ (fig. 206) of the circle whose centre is O represent the span of the girder, $c d$ = versine or camber at the centre—

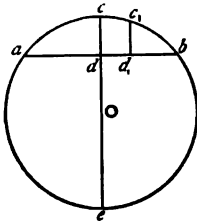

Fig. 206.

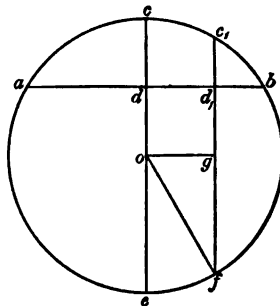

Fig. 206a.

Let $l = a d$, the half span,
 $v = c d$, the rise at centre,
 r = radius of the circle.

From the properties of the circle, we get—

$$a d \times d b = c d \times d e,$$

$$\text{or } l^2 = v (2 r - v).$$

$$\therefore r = \frac{l^2 + v^2}{2 v} \quad . \quad . \quad . \quad (16).$$

If v be small compared with the other dimensions, as is the case generally in cambered girders, we get approximately—

$$r = \frac{l^2}{2 v} \quad . \quad . \quad . \quad (17).$$

From this equation we can determine the radius of the curve knowing the span and camber.

Knowing the radius, we can determine the ordinate of any point in the curve when the horizontal distance of the ordinate from the centre of the curve is known.

$$\begin{aligned} \text{If } d d_1 = x \text{ and } c_1 d_1 = y, \\ \text{then } y = \sqrt{r^2 - x^2} - (r - v) \quad . \quad (18).^* \end{aligned}$$

254. Camber in Plate Girders.—In girders with continuous plate webs, the required camber may be practically produced by laying the web-plates on a temporary platform, stringing a line from one end to the other, and adjusting the plates so as to get their bottom edges at the different joints at the distances from the line as found from equation (18). The bottom edge of the plates will then approximately form the arc of a circle and the bottom angles, which have been previously punched or drilled, are bent to this curve, laid in their proper position on the web, and the position of the holes marked on it to correspond with those on the angles; the top angles are laid on in the same way,

* The truth of this formula may be demonstrated thus (fig. 206a)—

$$\begin{aligned} \text{Let } c_1 d_1 = y, \quad d d_1 = x, \quad c d = v, \\ r = \text{radius of circle whose centre is } o. \end{aligned}$$

By Euclid, prop. 35, Book III., we get—

$$\begin{aligned} c_1 d_1 \cdot d_1 f = a d_1 \cdot d_1 b; \\ \text{also } c_1 d_1 \cdot d_1 f = c_1 d_1 (d_1 g + g f) \\ = y \left\{ r - v + \sqrt{r^2 - x^2} \right\} \quad . \quad . \quad (1). \end{aligned}$$

Again by Euclid, prop. 5, Book II., we get—

$$\begin{aligned} a d_1 \cdot d_1 b &= (d b)^2 - (d d_1)^2 \\ &= r^2 - (d o)^2 - (d d_1)^2 \\ &= r^2 - (r - v)^2 - x^2. \quad . \quad . \quad (2). \end{aligned}$$

Equating (1) and (2) we get—

$$\begin{aligned} y \left\{ \sqrt{r^2 - x^2} + r - v \right\} &= r^2 - x^2 - (r - v)^2 \\ y &= \frac{r^2 - x^2 - (r - v)^2}{\sqrt{r^2 - x^2} + r - v} = \sqrt{r^2 - x^2} - (r - v). \end{aligned}$$

Q. E. D

after which the web is taken to pieces, and the holes in it punched or drilled. When the girder is afterwards put together it will be found to have the required camber.

255. Camber in Lattice Girders.

—Fig. 207 represents a lattice girder with an exaggerated camber. If the lattice bars be equal to each other, the lines which connect the points of intersection of the lattices with the top and bottom flanges will, if produced, all meet at the same point, *O*, which is the common centre of curvature of the top and bottom flanges. The panels into which the top flange is divided are longer than the corresponding panels of the bottom flange in the proportion of the radii of the two flanges.

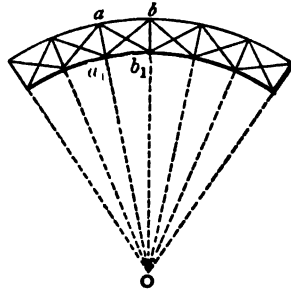

Fig. 207.

Let r_1 = radius of top flange,
 r = radius of bottom flange;

$$\text{then } \frac{ab}{a_1b_1} = \frac{r_1}{r}.$$

In order to produce the required camber in a lattice girder, it is only necessary to determine ab and a_1b_1 , and mark them off on the top and bottom flanges of the girder, the length of the lattices remaining the same throughout the girder. When this plan is adopted, it will be found that on putting the girder together it will have the camber which is desired.

Suppose, for example, we have a lattice girder 100 feet span and 10 feet deep, and it is required to give it a camber of 3 inches at the centre. Suppose the girder between the abutments to be divided into ten equal spaces, the lengths of the panels in the bottom flange being each equal to 10 feet.

From equation (17) we get—

$$r = \frac{(50)^2}{2 \times 0.25} = 5,000 \text{ feet};$$

$$r_1 = 5,010 \text{ feet};$$

$$a_1b_1 = 10 \text{ feet};$$

$$\therefore ab = 10 \times \frac{5,010}{5,000} = 10.02 \text{ feet.}$$

The panels into which the top flange is divided are, therefore, 0·02 foot or 0·24 inch longer than those in the bottom.

Another method of practically producing a camber in a lattice girder, is by keeping the top and bottom panels the same length, and making the lattice struts a little longer than they would be for a straight girder, and the lattice ties a little shorter.

Let f = working stress per unit of section to which the lattice bars will be exposed,

E = the modulus of elasticity of the material.

Then, in order that the girder may become straight when the material is exposed to the stress f , the struts should be made longer than those for a straight girder in the proportion of

$(1 + \frac{f}{E})$ to 1, and the ties should be shorter in the proportion of

$(1 - \frac{f}{E})$ to 1.

If, for example, a steel girder is designed so that its members are exposed to a working stress of 6 tons per square inch, and if the modulus of elasticity of the steel be 14,000 tons, and if the length of the lattice bars for a straight girder unloaded be 10 feet,

then the struts ought to be $10 + \frac{6 \times 10}{14,000} = 10$ feet 0·05 inch in

length, and the length of the ties should be $10 - \frac{6 \times 10}{14,000} = 9$ feet

11·95 inches, so that when the girder is fully loaded it may be quite straight.

CHAPTER XXI.

CONNECTIONS.

I. RIVETTED JOINTS.

256. **Different Methods of Joining Plates by Rivets.**—There are two principal methods of joining two plates or bars together by means of rivets or bolts. One is to make the plates overlap each other and rivet them in this position; the second method is to place the two ends flush together and connect them by

means of one or two strips overlapping each, and then rivet the whole together in this position.

Joints of the first description (see fig. 208) are termed *lap-joints*, and those of the second class (figs. 209 and 210) are termed *butt-joints*.



Fig. 208.

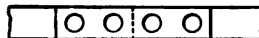

Fig. 209.

257. Rivets in Single- and Double-Shear.—In the joints shown in figs. 208 and 209, the rivets are in what is termed "*single-shear*," as each rivet can only be shorn at one section before the bars are pulled asunder. In the joint shown in fig. 210, the rivets are in "*double-shear*," as each rivet will have to be shorn across two sections before the bars can be pulled asunder. In addition to this shearing resistance the rivets confer upon the joint a further element of strength in the frictional resistance which they give to the plates. In the process of forming the rivet head by the machine or by hand, a certain amount of *grip* is given to the rivet on the plates; a further grip is obtained by the contraction of the rivet in cooling, this contraction pressing the plates powerfully together and causing a considerable tension on the rivet, so much so that in the case of long rivets the heads sometimes fly off. It is difficult to determine what value can be attached to the frictional resistance produced by this means, though cases have been known where the joint has been held together by this friction alone. In estimating the strength of a joint it is not usual to take this resistance into account, as in process of time, owing to the rusting of the plates and vibrations in the structure, the tension on the rivet may altogether disappear. When this frictional resistance is disregarded, the theoretic shearing stress on each rivet in a joint will be equal to the total stress on the bars divided by the number of sections of rivets that must be shorn in order to pull the bars asunder.

If P = total stress on the bars; then—

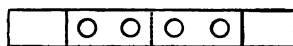

Fig. 210.

$$\begin{array}{l} \text{Stress on each rivet in figs. 208 and 209} = \frac{P}{2}, \\ \text{,, ,, fig. 210} = \frac{P}{4}. \end{array}$$

Practically, the shearing stress on each rivet may not be quite the same, one being subjected to a greater stress than another. However, if the holes are truly punched or drilled this difference of stress cannot be much.

258. **Shearing Strength of Rivets.**—The resistance of wrought iron to a shearing stress is not so great as the ultimate strength of the material under a direct tensile stress; and, further, this resistance varies according to the direction in which the shearing action takes place. From Wöhler's experiments, it appears that the shearing strength of a bar or plate of wrought iron in a plane perpendicular to the fibre is equal to $\frac{4}{5}$ ths of its ultimate tensile strength in the direction of the fibres. The shearing strength, in a plane parallel to the direction of the fibres, is from 18 to 20 per cent. greater than the above, and is about equal to the tenacity of the iron. So far as the shearing strength of rivets is concerned, it will only be necessary to consider their strength in a direction at right angles to the fibre, so that if the tenacity of rivet iron be 23 tons to the inch, its shearing strength will only be 18.4 tons or thereabouts. It has also been shown by numerous experiments, that the shearing strength of a rivet in a punched hole is slightly greater than that in a drilled hole, the reason assigned being that the sharp edge of a drilled hole facilitates the shearing process.

If we adopt 4 as a factor of safety, about 4.5 tons per square inch will be the safe working stress for iron rivets in iron plates. As rivet iron is of a better quality and stronger than the plates, some engineers adopt the rule of making the total rivet area in a tensile joint equal to the net sectional area of the plate. It is, however, a much better practice to have the rivet area 10 per cent. greater than this.

Theoretically, a rivet in double-shear ought to be twice as strong as a similar one in single-shear; the balance of evidence, however, from numerous experiments, shows that rivets in single shear are rather more than one-half as strong as those in double shear.

Iron rivets in steel plates are not so strong as those in iron plates; their strength being about 16 tons to the inch. It is not safe, therefore, to allow a working stress of more than 4 tons to the inch on iron rivets used in steel structures.

Steel rivets, which have a tensile strength of 30 tons, have a shearing strength of about 20 tons. The safe working stress to allow for these rivets should not exceed 5 tons to the inch.

259. **Strength of Lap-Joints.**—A lap-joint, as shown in fig. 211, may fail in at least four different ways, when exposed to a direct pull :—

(1) The rivet may be shorn, in which case the strength of the joint is measured by the shearing strength of the rivet.

Let d = diameter of the rivet in inches,

f_s = its shearing strength per square inch of section.

Then if the rivet be the weak portion of the joint, the force necessary to tear the joint asunder will be—

$$P = .7854 f_s d^2 \quad (1).$$

(2) The joint may fail by the rivet crushing one or both of the plates by forcing itself into them.

Let t = thickness of the plate,
 f_c = crushing strength of material in this position.

The force necessary to cause failure in this way is—

$$P = t d f_c \quad (2).$$

From experiments made, the value of f_c in this formula is very much greater than the ordinary crushing strength of the material; for wrought iron of ordinary quality $f_c = 40$ tons, or about double the crushing strength of the material. This discrepancy is explained by the fact that in the rivetted plate the metal crushed is not an isolated piece, but is supported by the surrounding portion of the plate, and also by the head of the rivet.

(3) The joint may fail by the splitting of the end of the plate along the line E F. According to Mr. Browne,* the strength of the joint in this case will vary directly as the square of E F and the thickness of the plate, and inversely as the diameter of the rivet.

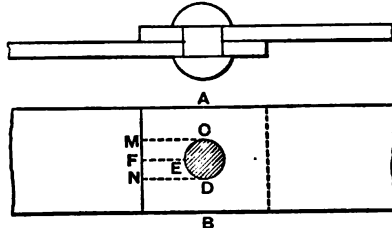

Fig. 211.

* *Min. Inst. M.E.*, 1872.

Let $EF = a$, then the strength of the joint along $EF = \frac{t a^2}{d} \times Q$, where Q is a constant.

From experiments made by Mr. Fairbairn he found for wrought iron that $Q = 38$ tons.

$$\therefore \text{Strength of plate at end} = \frac{38 t a^2}{d} \quad (3).$$

4. The joint may fail by one or both of the plates tearing across the line $ACDB$.

$$\text{Let } AC = BD = b,$$

$$f_t = \text{tensile strength of plate,}$$

$$\text{then strength of joint across } ACDB = 2 b t f_t \quad (4).$$

A fifth way in which the joint may fail is mentioned by Mr. Browne. This occurs by the rivet forcing a piece out of the end of the plate, in which case the resistance against failure

$$= (CM + DN) \times t \times f_s \quad (5),$$

where f_s = ultimate shearing strength of the material.

Failure by this method very rarely happens.

Example 1.—Two flat bars of wrought iron each 3 inches wide by $\frac{1}{2}$ inch thick are lap-jointed by a single rivet 1 inch in diameter. If the centre of the rivet be $1\frac{1}{2}$ inches from the end of each bar, determine the tensile force necessary to break the joint in each of the five different ways above enumerated.

$$t = \frac{1}{2}, \quad d = 1, \quad f_t = 19 \text{ tons, } f_s = 40 \text{ tons, } f_c = 18 \text{ tons.}$$

P = required tensile force in tons.

1. From equation (1)—

$$P = .7854 \times 19 \times (1)^2 = 15 \text{ tons,}$$

which is the force necessary to shear the rivet.

2. From equation (2)—

$$P = \frac{1}{2} \times 1 \times 40 = 20 \text{ tons,}$$

which is the force necessary to cripple the bars.

3. From equation (3)—

$$P = \frac{\frac{1}{2} (1)^2}{1} \times 38 = 19 \text{ tons,}$$

which is the force necessary to split the end of the bar.

4. From equation (4)—

$$P = 2 \times 1 \times \frac{1}{2} \times 18 = 18 \text{ tons,}$$

which is the force necessary to tear the bar across the eye.

The tensile strength of the iron is supposed to be equal to 22 tons, but in this case 18 tons is sufficient to allow, as the fibres at one side of the hole may be strained to a greater extent than those at the other, whereby there is a tendency for the bar to be broken in detail.

5. From equation (5)—

$$P = \frac{1}{2} (1\frac{1}{2} + 1\frac{1}{2}) \times 19 = 28.5 \text{ tons,}$$

which is the force necessary to push out the iron at the end of the bar in the manner explained.

From the above it will be seen that the joint is fairly well proportioned, the rivet itself being, however, the weak part. It will also be seen that failure by the fifth method is not likely to occur. Indeed, in joints of this class this method of failure need not be taken into consideration.

260. Proportions of Joints.—In order to determine the relative proportions of the various parts of a lap-joint connected by a single rivet, it will be necessary to compare the equations (1) to (5).

To arrive at the relative proportions of the diameter of the rivet and the thickness of the plate compare equations (1) and (2).

When the joint fails simultaneously from the shearing of the rivet and the crushing of the plate, we get—

$$.7854 f_r d^2 = t d f_c$$

Putting $f_r = 19$ and $f_c = 40$, we get—

$$\frac{d}{t} = 2.7,$$

which shows that with wrought-iron plates, connected by wrought-iron rivets, the diameter of the rivet should be between two and three times the thickness of the plates. The ordinary rule in boiler work is to make the diameter of the rivet twice the thickness of the plates.

M. Antoine gives the following empirical formula for the diameter of rivets as used in shipbuilding:—

$$d = 1.1 \sqrt{t}$$

In order to determine the distance of the rivet from the end plate (a), or in other words to find the requisite amount of lap, we must equate (1) and (3), or—

$$\cdot 7854 f_1 d^2 = 38 \cdot \frac{t a^2}{d}.$$

By putting $t = \frac{d}{2}$ we get—

$$15 d^2 = 19 a^2, \text{ or } a = 0.9 d;$$

that is, the distance of the edge of the rivet from the end of the plate should be rather less than the diameter of the rivet.

The ordinary rule in practice is to make this distance equal to the diameter of the rivet; the lap of the joint will then be three times the diameter of the rivet—that is, when the latter is double the thickness of the plate.

In order to determine the distance of the edge of the plate from the rivet, or when more than one rivet is used to determine the pitch of the rivets, we must compare equations (1) and (4). Equating these we get—

$$\cdot 7854 f_1 d^2 = 2 b t f_2.$$

Putting $f_1 = 19$ and $f_2 = 18$ we get—

$$b = 0.42 \times \frac{d^2}{t}.$$

If $d = 2 t$ we get—

$$b = .84 d, \text{ or } b = d \text{ nearly.}$$

For a lap-joint, therefore, with a single rivet, the width on each side of the rivet should be equal to the diameter of the rivet, and also when more than one rivet occurs transversely, the distance between their edges should be twice the diameter, or their pitch—*i.e.*, their distance apart from centre to centre—should be equal to three times the diameter of the rivet.

261. Double-Riveted Lap-Joints.—In boiler work the following proportions for double-riveted lap-joints with punched holes are common:—

$$\begin{aligned} \text{Diameter of rivet} &= \text{twice the thickness of the plate,} \\ \text{Pitch of rivets} &= 4\frac{1}{2} \text{ diameters,} \\ \text{Lap} &= \begin{cases} 5\frac{1}{2} \text{ diameters in chain rivetting,} \\ 6 \quad \quad \quad \text{,,} \quad \quad \quad \text{zig-zag} \quad \quad \quad \text{,,} \end{cases} \end{aligned}$$

The following are the proportions between the strength of the plate and single- and double-riveted lap-joints :—

Strength of unpunched plate	= 100.
„ double-riveted joint	= 66 to 70.
„ single- „ „	= 50 to 55.

Lap-joints are principally employed in boiler-making and ship-building; they are cheaper than butt-joints as only half the amount of punching or drilling is required, and they possess many advantages which will always render them desirable for this class of work.

In bridges, and structural work generally, lap-joints are not much used, and are not desirable; butt-joints with single or double cover-plates being almost invariably employed. When two plates are joined together by a lap-joint and exposed to a tensile stress, the direction of the stress in one plate is not exactly in a line with that in the other, but forms with it a couple which has a tendency to bend the joint. This tendency to bend does not exist, or only to a very small extent, when butt-joints are used.

When it becomes necessary to use a lap-joint to connect two plates in a structure, a very good form is that shown in fig. 212. In this arrangement each plate is practically weakened only to the extent of one hole. The full stress on each plate comes at the sections ab and cd respectively, and here the plates are only weakened to the extent of one hole. At the sections a_1b_1 and c_1d_1 , where there are two holes, the stress on the plates is less than the total stress by the amount taken up by the end rivet in each case. At the section ef , where there are three holes, the stress on each plate is less than the total stress

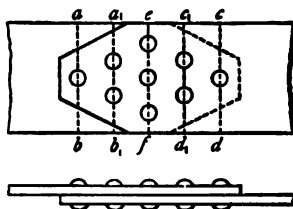

Fig. 212.

by the amount taken up by the three end rivets. In order to illustrate this, suppose each of the plates to be 8 inches wide and $\frac{1}{2}$ inch thick, and to be joined together by nine $\frac{3}{4}$ -inch rivets, and suppose the tensile strength of the plates and the shearing strength of the rivets, each equal to 20 tons per square inch.

The net section of each plate at ab or $cd = 7.25 \times .5 = 3.625$ square inches. The plates will be on the point of yielding when the total pull = $3.625 \times 20 = 72.5$ tons. When this force is applied, the stress at the sections a_1b_1 and c_1d_1 of the back and

front plates respectively = $72.5 - .44 \times 20 = 63.7$ tons, the amount 8.8 tons being taken up by each of the end rivets. The unit stress at $a_1 b_1$ or $c_1 d_1 = \frac{63.7}{3.25} = 19.6$ tons per square inch, or rather less than the unit stress on the plates.

Again the net section of each plate through $e f = 5.75 \times .5 = 2.875$ square inches, and the stress on each plate at this section = $72.5 - 3 \times .44 \times 20 = 46.1$ tons. This gives $\frac{46.1}{2.875}$, or 16 tons per square inch as the unit stress at this section.

The strength of the rivets = $9 \times .44 \times 20 = 80$ tons.

Theoretically this joint ought to fail either through $a b$ or $c d$, where the plates are weakened to the extent of one hole. There is no necessity for continuing the plates their full width to their extreme ends, and they may with advantage be tapered off as shown in the figure.

262. Butt-Joints with Single Covers.—In butt-joints the two plates or bars to be joined together are made to abut against each other at their ends, and are connected together either by a single or double cover-plate. Fig. 209 represents a butt-joint with a single cover-plate; each half of this joint is in effect simply a lap-joint, and all the rivets are in single shear. The thickness of the cover should be at least equal to that of the plates; some engineers prefer it a little thicker. For wrought-iron plates and rivets, the collective sectional area of the rivets at each side of the joint should be not less than 10 per cent. in excess of the net sectional area of the plate for a tensile stress.

The rules given for a tensile joint also apply to a compressive joint, when the ends of the plates do not butt evenly together. When the ends of the plates are faced or squared so as to form a sound butt, theoretically, the joint does not require a cover at all, but as the butting cannot always be relied upon, it is best to have a cover, though it need not always be so thick or so long as that for the tension joint.

263. Butt-Joints with Double Covers.—Fig. 210 shows a butt-joint with double covers. Here the rivets are in double shear, so that before they fail each one must be shorn across two sections. The number of rivets at each side of the joint in this case need only be one-half that required when only a single cover is used. The united section of both covers should be at least equal to the section of the plate; it is always better, however, to have it in excess, say to the extent of from 10 to 20 per cent. In covering the joints in the flanges of girders it is more

economical to use double covers when practicable; as the length of each cover-plate is only one-half that of a single cover, and as they do not need to be much more than half the thickness, the saving in weight as well as in rivetting is obvious.

An economical method of joining two plates together by means of a butt-joint with double covers is that shown in fig. 213. If this joint be properly designed the strength of the plate will only be diminished to the extent of one rivet hole. When a joint of this kind is exposed to a tensile stress it may fail in one of the following ways:—

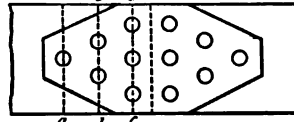

Fig. 213.

(1) By the plate tearing through at $a a$, where its area is reduced by one rivet hole; (2) by the plate tearing through at $b b$ at the same time that the rivet a is double shorn; (3) by the plate tearing through at $c c$ at the same time that the three rivets at $a a$ and $b b$ are double shorn; (4) by both covers tearing through at $c c$; (5) by the six rivets at one side of the joint being double shorn; (6) by the rivets crushing the plates or covers.

Example 2.—In the joint shown in fig. 213 determine the direct tensile stress which will cause the failure of the joint in the six different ways specified; the plates being 9 inches wide and $\frac{1}{2}$ inch thick; each of the covers being $9'' \times \frac{5}{16}''$, and the rivets being $\frac{3}{4}$ inch in diameter. The tensile strength of the plates is supposed to be 20 tons, and the shearing strength of the rivets 18 tons per square inch.

The net section of the plate at $a a$	=	$(9 - .75) \times .5 = 4.125$ sq. ins.
" " "	=	$b b = (9 - 2 \times .75) \times .5 = 3.75$ "
" " "	=	$c c = (9 - 3 \times .75) \times .5 = 3.375$ "
" " two covers at $c c$	=	$(9 - 3 \times .75) \frac{5}{8} = 4.22$ "
The shearing area of rivets at each side of joint	} =	$2 \times 6 \times .44 = 5.28$ "

Let P = tensile force in tons necessary to produce rupture.

(1) . . . $P = 4.125 \times 20 = 82.5$ tons,

which is the force necessary to tear the plate through $a a$.

(2) . . . $P = 3.75 \times 20 + 2 \times 0.44 \times 18 = 90.84$ tons,

which is the force necessary to tear the plate through bb and shear the rivet at aa .

$$(3) \quad P = 3.375 \times 20 + 6 \times 0.44 \times 18 = 115 \text{ tons,}$$

which is the force necessary to tear the plate through cc and shear the three rivets at aa and bb .

$$(4) \quad P = 4.22 \times 20 = 84.4 \text{ tons,}$$

which is the force necessary to tear both cover plates through cc .

$$(5) \quad P = 5.28 \times 18 = 95 \text{ tons,}$$

which is the force necessary to shear the six rivets at either side of the joint.

(6) The force necessary to crush the plate is—

$$P = 6 \times \frac{3}{4} \times \frac{1}{2} \times 40 = 90 \text{ tons ;}$$

and to crush the covers—

$$P = 6 \times \frac{3}{4} \times \frac{5}{8} \times 40 = 112.5 \text{ tons.}$$

From this it will be seen that the joint is very fairly proportioned. Its weakest part being through aa , and here its strength is equal to 91.6 per cent. of that of the unpunched plate.

It would not do to have the cover-plates less than $\frac{1}{8}$ inch in thickness, as failure would then take place by their tearing across through cc ; as it is they are slightly stronger than the plate. It is well that this should be so, as it is possible one of the plates may be strained to a greater extent than the other, in which case they might be broken in detail. The rivets themselves give a good margin

of strength, and there is not much danger of the plate tearing through bb or cc , as the loss in strength from the extra hole in each case is more than compensated by the shearing strength of the rivets at aa and bb .

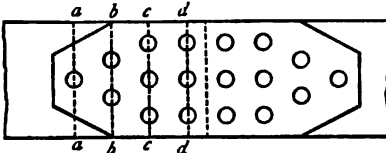

Fig. 214.

Fig. 214 represents the two plates given in the last example joined by means of a single cover-plate $\frac{1}{8}$ inch in thickness; there are nine $\frac{7}{8}$ -inch rivets at each side of the joint, arranged in the manner shown in the sketch.

The net section of the plate at $aa = (9 - \frac{7}{8}) \times \frac{1}{4} = 4.0625$ sq. ins.

” ” ” $bb = (9 - 2 \times \frac{7}{8}) \times \frac{1}{2} = 3.625$ ”

” ” ” cc or $dd = (9 - 3 \times \frac{7}{8}) \times \frac{1}{2} = 3.1875$ ”

The net section of the cover }
through dd } $= (9 - 3 \times \frac{7}{8}) \times \frac{1}{16} = 4.38$ ”

The shearing section of rivets }
at each side of joint } $= 9 \times 0.6 = 5.4$ square inches.

The force necessary to tear the plate at aa is—

$$P = 4.0625 \times 20 = 81.25 \text{ tons.}$$

The force necessary to tear the plate at bb and at the same time shear the rivet at aa , is—

$$P = 3.625 \times 20 + 0.6 \times 18 = 83.3 \text{ tons.}$$

The force necessary to cause the failure of the plate at cc is—

$$P = 3.1875 \times 20 + 3 \times 0.6 \times 18 = 96.15 \text{ tons.}$$

To produce the failure of the plate at dd —

$$P = 3.1875 \times 20 + 6 \times 0.6 \times 18 = 128.55 \text{ tons.}$$

To produce the failure of the cover-plate at dd , its weakest section—

$$P = 4.38 \times 20 = 87.6 \text{ tons.}$$

To produce the failure of the rivets by shearing—

$$P = 5.4 \times 18 = 97.2 \text{ tons.}$$

To cause failure by the crippling of the iron behind the rivets in the plate—

$$P = 9 \times \frac{7}{8} \times \frac{1}{2} \times 40 = 157.5 \text{ tons.}$$

It will be seen from this that the joint is very well designed, and is nearly, though not quite, as strong as that with double covers.

264. Joints in the Flanges of Girders.—It is not possible to introduce the economical forms of joint shown in figs. 213 and 214 in covering the joints in the flange-plates of girders; practical considerations not allowing of the form of rivetting shown.

Suppose we have a wrought-iron girder with a single flange-plate 12 inches wide and $\frac{1}{2}$ inch thick, the thickness of the web being $\frac{1}{2}$ inch, and the connecting angles being $2\frac{1}{4}'' \times 2\frac{1}{4}'' \times \frac{1}{2}''$, it is

required to determine the best method of covering a tensile joint in the plate with a single cover.

The longitudinal pitch of the rivets = 4 inches,
Diameter of rivet = $\frac{3}{4}$ inch.

First let us assume that there are only two longitudinal rows of rivets in the flange.

Net section of plate = $(12 - 2 \times 0.75) \times \frac{1}{2} = 5.25$ sq. ins.

The area of a $\frac{3}{4}$ -inch rivet = 0.44.

The number of rivets required whose gross sectional area is equal to the net area of the plate = $\frac{5.25}{0.44} = 12$. As it is advisable

to have an excess of rivet area it would be safer to have 14 rivets at each side of the joint. It must be borne in mind, however, that the diameter of a $\frac{3}{4}$ -inch rivet is rather more than $\frac{3}{4}$ inch; in fact it may be reckoned as $\frac{7}{8}$ inch. Taking this into consideration, the sectional area of the 12 rivets will be 5.76 square inches, as against 5.25 square inches, the net section of the plate, or an excess of 10 per cent. If 12 rivets be taken, the length of the cover plate will be 4 feet.

Fig. 215 shows another method of covering this joint. In this case there are four rows of rivets arranged in a zig-zag fashion, the number of rivets at each side of the joint being 14, and the length of the cover 2 feet 8 inches. The strength of the plate or cover is rather less in this case than in the former, its smallest section not being directly transverse through two rivet holes, but zig-zag, as shown by the dotted line *a d*.

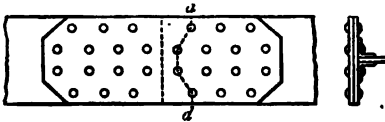

Fig. 215.

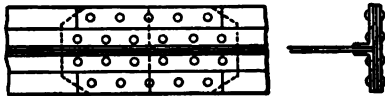

Fig. 216.

Fig. 216 shows a third method of covering this joint. Here, in addition to the bottom cover-plate, there are two cover-strips placed on the other side of the plate. These have the effect of placing the outside rows of rivets in double shear.

Bottom cover-plate = $12'' \times \frac{3}{8}'' = 4.5$ sq. inches.

Top cover-strips = $2 \times 3\frac{1}{4}'' \times \frac{3}{8}'' = 2.4$ „

Total section of cover-plates = $\overline{6.9}$ „

There are 6 rivets in single shear and 4 in double shear.

Total rivet section = $14 \times .44 = 6.16$ sq. inches.

265. Joints in a Girder Flange consisting of a Number of Plates. —When the flange of a girder consists of a number of plates of the same width and thickness, the most economical method of arranging the joints is to place them close together in steps, as shown in elevation in fig. 217. The distance apart of the joints should be such that the shearing area of the rivets between each be not less than the net section of each plate.

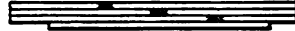

Fig. 217.

If l = distance apart of joints, then, in the case of three plates, the length of the cover-plate = $4l$.

If the joints be placed far apart, each one must be covered with a separate plate, and in such case the length of each cover = $2l$, so that for the three joints the total length of cover-plates = $6l$.

Another advantage of placing the joints close together in large girders is the facility with which they may be disjointed, if it be necessary to transport them to their destination in several lengths; and the ease with which they can be afterwards jointed and rivetted together *in situ*.

II. PROPORTIONS OF EYES.

266. Method of Connecting Bars Together.—Bars of wrought iron or steel, when not joined by rivets, are usually connected together by bolts, pins, or cotters; and in order to do this the ends of the bars are frequently swelled out in the form of an eye. As the strength of the connection should at least be as great as that of the bar itself, it is important to know what are the best proportions to give to the eye and to the connecting pin; the latter usually being in double shear.

Examples of bars joined together in this manner are very numerous, such as the links in the chains of suspension bridges; the diagonal braces of trussed girders; the tension members of roof trusses, &c.

Fig. 218 represents the eye formed at the end of a flat bar, the thickness of the eye and that of the bar being the same.

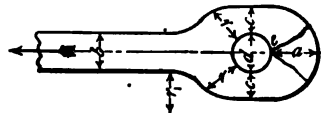

Fig. 218.

Let b = width of bar,
 d = diameter of the pin,
 c = width of eye at each side of pin-hole.

If a stress be applied in the direction of the arrow, the lines of stress in the shank will run longitudinally, but towards the pin-hole they become diverted, so that the fibres immediately to the left of the pin are exposed to little or no stress. The fibres to the right of the pin-hole undergo various kinds of complex stresses, principally of a compressive and shearing nature.

267. Proportions of Eyes.—The best proportions to give to the eye cannot be determined by considerations of a merely theoretical nature, and we must look to the results of actual experiments for aid to guide us in fixing them. Fortunately, we have plenty of materials of this kind to guide us; the experiments made by Sir C. Fox, Brunel, Berkley, Shaler Smith, and others being very complete.

A flat eye, when exposed to stress, may fail in many ways; the following being the principal:—

1. By tearing across the eye through c , c ;
2. By tearing through the shoulders at r , r ;
3. By the end of the link being torn through at a ;
4. By the metal of the link being upset or crushed immediately behind the pin at e ;
5. By the pin being bent or shorn.

These different modes of failure may be considered in detail:—

(1) On theoretical grounds, if the section of the eye across the pin-hole be equal to that of the bar, or if $c + c = b$, the eye in this direction ought to be as strong as the bar itself. Experiments made prove this to be incorrect, and in practice it is advisable to make this section at least 25 per cent. greater. From this it would appear that the stress on the fibres, at the sides of the link, are not uniform; probably the outside fibres are strained more than those near the pin, which would cause them to fail first. This difference of stress in the fibres will be greater the sharper the curve at the shoulders.

(2) The failure from the second cause is likely to occur when the curvature at the shoulder is so small as to prevent the lines of stress bending gradually round the eye. Mr. Berkley recommends that the radius of curvature of the shoulder r should not be less than b , and that the radius of curvature r_1 of the neck should not be less than $1.5 b$.

(3) The metal at the back of the pin may be exposed both to bending and shearing stresses; it, in fact, resembles a short

beam whose points of support are at *c, c*. It may fail by being shorn through, or by the tearing of the fibres on the outside. In order to resist the shearing action, theoretically, the section at *a* should be rather more than one-half that of the bar. In practice, however, the end of the link does not fail by shearing, but by the tearing of the fibres at the outer circumference. Mr. Brunel considers that the section through *a* should be about two-thirds that of the bar. This, however, is not sufficient in all cases. Mr. Berkley recommends that the section at *a* should be at least equal to that of the bar, and this is the safest rule to adopt.

(4) Failure by this means takes place when the diameter of the pin is so small that the bearing surface immediately behind it is too little to transmit the stress without crushing the fibres, and thus elongating the hole. Failure by this method rarely takes place directly, but the elongation of the hole causes the attenuation of the metal at the sides of the pin and brings about failure by the first method. Mr. Berkley recommends a diameter for the pin equal to three-fourths the width of the bar, and in practice this will be found safe.

(5) The pin may fail by shearing or bending when its diameter is too small. Even when the diameter is sufficiently large to resist shearing, the pin may fail by bending; this, however, may be provided against by keeping the links close together. The minimum diameter of the pin depends on the material used; if both link and pin be of wrought iron and the latter be in double shear, its sectional area, as determined from experiments, should be at least equal to two-thirds the area of the bar. If they are both made of mild steel the area of the pin should be greater.

It will be found, however, that in links of the usual proportions the diameter of the pin will be fixed by the rule given in No. 4; its diameter, as fixed by this rule, will generally be found quite sufficient to resist the shearing stress.

Mr. Berkley recommends the following minimum proportions for wrought-iron flat eye-bars:—

Width of bar, <i>b</i> ,	= 100,
Diameter of pin, <i>d</i> ,	= 75,
Depth of lead beyond pins, <i>a</i> ,	= 100,
Width of metal across eye, <i>c + c</i> ,	= 125,
Radius of curve of shoulder, <i>r</i> ,	= 100,
Radius of curve of neck, <i>r</i> ₁ ,	= 150.

268. Rules of American Engineers.—The practice of American engineers is somewhat different to that adopted by the English

authorities already mentioned. Mr. Shaler Smith, an American authority, finds from his experiments that the best proportions for eye-bars depend to a certain extent on their method of manufacture.

The following table gives some of the results of Mr. Smith's experiments:—

TABLE LXXXVIII.—PROPORTIONS OF AMERICAN EYE-BARS, AS DETERMINED BY MR. SHALER SMITH.

Width of shank. <i>b</i> .	Diameter of pin. <i>d</i> .	HAMMERED EYES.		WELDLESS EYES.	
		Metal section across the eye. <i>c+c</i> .	Maximum thickness of bar.	Metal section across the eye. <i>c+c</i> .	Maximum thickness of bar.
1.00	0.67	1.33	0.21	1.50	0.21
1.00	0.75	1.33	0.25	1.50	0.25
1.00	1.00	1.50	0.38	1.50	0.38
1.00	1.25	1.50	0.54	1.60	0.54
1.00	1.33	1.70	0.59
1.00	1.50	1.67	0.70	1.85	0.70
1.00	1.75	1.67	0.88	2.00	0.88
1.00	2.00	1.75	1.08	2.25	1.08

269. *Gibs and Cotters.*—Gibs and cotters are frequently used instead of bolts or pins for connecting the ends of tie rods. Their principal recommendation is that they afford means of slackening or tightening the rods, which is often an advantage, as in the case of the ties of roof trusses, &c. A cotter itself is merely a tapered bar, rectangular in cross-section, and usually made of wrought iron or steel. Fig. 219 shows the method of

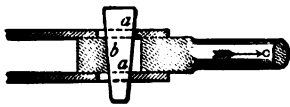

Fig. 219.

connecting a bar to two plates by a simple cotter. The end of the bar is swelled out, and a slot cut in it; slots are also cut in the junction plates. When the stress on the bar acts in the direction of the arrow, the cotter bears against

the plates at the surfaces *a a*, and against the bar at the surface *b*.

By the arrangement shown, it will be seen that the bar can be drawn towards the connecting plates as the cotter is driven in.

The sectional area taken through the slot in the bar should be at least 25 per cent. greater than the sectional area of the bar itself. In actual practice it is usual to make this excess of area somewhat more. The cotter being in double shear, the united area of both sections should never be less than 25 per cent. greater than the bar, and it is advisable to have the excess of area 50 per cent. The cotter should not be made too thin or it will crush the surfaces against which it bears.

270. Proportions of Cotters, &c.—Suppose the bar C (fig. 219) has to transmit a safe working stress = P , it is required to determine a suitable diameter for the bar, and the best proportions for the eye, cotter, and connecting plates.

- Let f_t = safe tensile working stress on the material,
- f_s = safe shearing " "
- f_c = safe compressive " "
- d = diameter of the bar,
- b = mean width of the cotter,
- t = thickness of the cotter,
- a_1 = thickness of the side plates,
- d_1 = side of the square into which the end of C is forged.

For the bar C, we get—

$$P = \frac{\pi}{4} d^2 f_s \text{ or } d^2 = \frac{4 P}{\pi f_s} \quad (1).$$

From this equation we can determine the diameter of the bar.

In order to determine the size of the head, we get, by taking a section through the cotter hole—

$$P = d_1 (d_1 - t) \times f_s \quad (2)$$

from which d_1 may be found when t is fixed. This gives the theoretic size of the head ; but, as already explained, the actual sectional area through the slot should be from 25 to 50 per cent. greater than that given by this rule.

For the cotter, we get—

$$P = 2 b t f \quad (3).$$

From this equation b and t may be found having fixed one of them.

As previously explained, 50 per cent. should be added to the theoretic dimension, as found by this rule.

For the bearing surface of the cotter on the eye, we get—

$$P = d_1 t f_c \quad (4),$$

from which t may be found when d_1 is fixed.

For the bearing surface of the cotter on the side plates—

$$P = 2 a_1 t f_c \quad (5),$$

from which a_1 may be found when t is fixed.

Prof. Unwin gives the following as the values of the limit of the safe working stresses (in pounds per square inch) in tension, compression, and shearing in connections of this kind :—

TABLE LXXXIX.

	Wrought Iron.	Cast Iron.	Steel.
Tearing resistance f_t . . .	10,400	3,600	15,000
Shearing resistance f_s . . .	8,320	2,700	12,000
Crushing resistance f_c . . .	20,800	20,800	30,000

CHAPTER XXII.

PUNCHING, DRILLING, AND RIVETTING.

271. Methods of Perforating Plates.—There are two methods of perforating plates, namely, by (1) Punching; (2) Drilling. A third method is sometimes followed—viz, to punch a small hole and then drill it out to the right size. A considerable difference of opinion exists among engineers as to the relative merits of these different methods. For wrought-iron structural work the general practice up to a comparatively recent period has been to punch the holes; it being found more expeditious and cheaper than drilling. The tendency of late years, however, has been in the direction of supplanting punching in favour of drilling, more especially since the introduction of mild steel as a material for structural work. This new departure has compelled

bridge-builders to lay down suitable drilling plant; and with this, the extra cost of drilling over that of punching is not great.

272. **Punching.**—In punching plates, it is customary at most bridge-works to make the punch about $\frac{1}{16}$ inch larger in diameter than the rivet. The excess of the diameter of the die over that of the punch varies with the thickness of the plate punched—the thicker the plate, the greater the excess. Thus, in punching a hole for a $\frac{3}{4}$ -inch rivet in a $\frac{3}{4}$ -inch plate, the punch should be $\frac{13}{16}$ inch in diameter and the die $\frac{29}{32}$ inch. For an inch rivet in an inch plate the punch should be $1\frac{1}{16}$ inch and the die $1\frac{3}{16}$ inch in diameter. The hole as punched resembles the frustrum of a cone, the diameter at the small end being equal to that of the punch and at the large end equal to that of the die, so that the mean diameter of the punched hole is equal to that of the nominal diameter of the rivet *plus* one-half the clearance of the punch and die together.

It is very important in order to get good work that the above regulations should be adhered to, and also that both punches and dies be in a proper state of repair. If these precautions were more commonly observed, a great deal of the objection and prejudice which prevails against punching would not exist.

273. **Weakening effect of Punching and Drilling.**—Mr. Cochrane* made a number of experiments with the object of determining to what extent the strength of ordinary wrought-iron structures was affected by the processes of punching and drilling; and to see if, for ordinary girderwork, drilling has any advantage over punching. His experiments were made on two classes of iron, viz:—Low Moor, which was soft and fibrous, and Staffordshire, which was hard and crystalline.

He found that the drilled and punched bars were practically of the same strength. In the case of the Staffordshire iron, the drilled bar was actually about 2·3 per cent. weaker than the punched bar, and in the Low Moor about 1 per cent. stronger, the specimens being $\frac{1}{2}$ inch thick. When the plates are thicker, the process of drilling weakens the plates less than that of punching, and the thicker the plate the greater the difference.

It may be stated generally, that for ordinary wrought-iron bridgework, punching is quite as good as drilling when the work is properly done. The case is rather different, however, with large girders, when there are five or six thicknesses of flange plates. In such cases the advantages of drilling the flanges are obvious. With punching it is difficult to get the holes in the different layers exactly over each other, so that drifting or

* *Pro. Inst. of Mech. Eng.*, 1872, p. 79.

TABLE XC.

No. of Experiment	Thickness of plates.	Description.	Size of holes.	Breaking stress in tons per square inch.	Percentage of loss from strength of solid plate.	Remarks.
	Inch.		Inches.			
1	0.75	Plain	...	19.92	...	
2	0.78	{ Punched with open die }	1.08-1.25	15.59	22.0	Slightly crystalline.
3	0.78	{ Punched with closed die }	1.08-1.18	15.90	20.0	"
4	0.78	{ Punched with closed die }	1.08-1.17	15.3	23.0	"
5	0.75	{ Punched and rimmed }	1.16	17.66	11.4	
6	0.75	{ Punched and annealed }	1.08-1.18	19.13	4.0	
7	0.78	Drilled	1.14	19.11	4.0	{ Silky fracture. Very slightly crystalline.

rimering would be necessary. When the flanges of such girders are to be drilled, the plates should be first placed in position and the drilling done through the solid flange *in one operation*. By this means true holes may be obtained, and there will be no necessity for drifting.

With wrought-iron plates over $\frac{3}{8}$ inch in thickness, the advantages of drilling over punching as affecting the strength of the plates become very apparent.

Table XC. gives the result of some experiments made by Mr. Parker of Lloyd's on the strength of punched and drilled wrought-iron plates $\frac{3}{4}$ inch thick.

In bars of small section, such as are frequently used in lattice girders and roof work, drilling should be employed in preference to punching. When a hole is punched close to the edge or the end of a bar, there is a danger of the iron bulging or splitting. For the same reason when the holes are close together they should be drilled.

274. Punching and Drilling Mild Steel.—Four methods may be adopted in perforating steel plates or bars, viz. :—

- | | |
|---------------------------|----------------------------|
| 1. Punching. | 3. Punching and annealing. |
| 2. Punching and rimering. | 4. Drilling. |

It has been found by repeated experiments that the weakening effect produced on mild steel plates by punching depends on the thickness of the plates and also the kind of punch used.

The open die or conical punching causes less loss of strength than a close die, which produces a nearly parallel hole. From some experiments made by Messrs. W. Parker and W. John, they found that in punched holes with a taper of only $\frac{1}{16}$ inch the loss of strength in the plate was 17·8 per cent. When the taper of the hole was $\frac{1}{4}$ inch, the loss of strength in the same plate was only 12·3 per cent.

The above experiments also showed that the weakening effect on thin plates was much less than on thick ones. The loss of strength in $\frac{1}{4}$ -inch and $\frac{3}{8}$ -inch plates was only 8 per cent., in $\frac{1}{2}$ -inch plates 26 per cent., while in $\frac{3}{4}$ inch and $\frac{7}{8}$ inch it rises as high as 33 per cent.

The effect of punching thick steel plates not only greatly reduces their strength, but also diminishes their ductility. The injury done to the material, however, is confined to a zone of metal round the hole, less than $\frac{1}{8}$ inch thick; for if a $\frac{3}{4}$ -inch hole be punched and then rimed out to 1 inch or even $\frac{7}{8}$ inch, it will be found that the perforated plate is as strong per square inch as

the solid plate. Another method of restoring the strength is to anneal the plates after punching.

It is a curious fact that thin steel plates, say up to $\frac{3}{8}$ inch or $\frac{7}{16}$ inch, suffer less loss of strength in punching than do wrought-iron ones of the same thickness; while in thicker plates, or those beyond $\frac{1}{2}$ inch, the loss in steel plates is greater than in iron.

The general conclusion to be drawn from the above is that mild steel, as used for constructional work, may be safely punched up to $\frac{1}{2}$ inch thick, and there is no necessity for riming or annealing. When over $\frac{1}{2}$ inch and under $\frac{3}{4}$ inch the plates should be drilled, or else annealed or rimed after punching; and, for thicknesses beyond $\frac{3}{4}$ inch, it is advisable to drill the holes. At all the principal shipbuilding yards of this country, punching, within the limits above named, is permitted by the Admiralty and Lloyd's inspectors.

275. Increase of Strength due to Perforation.—Mr. Kennedy made some experiments on the punching and drilling of $\frac{1}{2}$ -inch and $\frac{3}{8}$ -inch steel plates, which are of interest. The tenacity of the $\frac{1}{2}$ -inch plates was 34·4 tons, and that of the $\frac{3}{8}$ -inch plates 31·45 tons per square inch, before punching or drilling.

After drilling, the strength of the $\frac{1}{2}$ -inch plates was increased by 10·7 per cent., and that of the $\frac{3}{8}$ -inch plates by 11·9 per cent.

After punching, the $\frac{1}{2}$ -inch plate, in spite of the injury done by punching, showed an excess of tensile strength equal to 1·2 per cent. greater than the unperforated plate. In the $\frac{3}{8}$ -inch plate, perhaps on account of its greater mildness, the excess of strength was as much as 8 per cent.

276. Strength of Rivets in Punched and Drilled Holes.—According to Fairbairn and other authorities, the shearing resistance of rivets in drilled holes is less than that of those in punched holes, which appears to be due to the sharp edges of the former. It is found that by rounding the edges a greater shearing resistance is obtained. The following may be taken as the proportions:—

	Shearing resistance of rivets in tons per sq. inch.
Punched holes,	20·95
Drilled holes,	19·23
Rounded holes,	21·52

RIVETS AND RIVETTING.

277. Different forms of Rivet-heads.—Rivets are made from round bars of wrought iron or mild steel of the requisite diameter, by heating them in a furnace, cutting them to the required length, and forming a head of suitable shape by means

of a die worked by machinery. The heads of rivets are made of a variety of forms; those shown in figs. 220 to 224 being the most common.

Figs. 220 and 221 are termed *cup-headed* or *snap-headed* rivets; the diameter of the head being about 1.75 times that of the rivet, and its depth about five-eighths the diameter of the rivet.

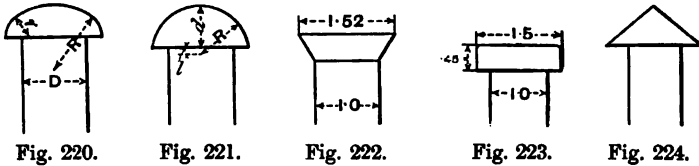

Fig. 223 is termed a *pan-headed* rivet, while that shown in fig. 224 is called a *conical-headed* rivet, and that in fig. 222 a *countersunk-headed* rivet.

The following proportions of rivet heads are commonly employed:—

Ellipsoidal (fig. 220)—

D = diameter of rivet,
 R = large radius = D,
 r = small radius = .4 D,
 d = depth of head at centre = $\frac{5}{8}$ D.

Segmental (fig. 221)—

D = diameter of rivet,
 d = depth of head at centre = $\frac{5}{8}$ D,
 R = radius of rivet-head = $\frac{3}{4}$ D,
 l = depth of centre below shoulder = $\frac{1}{8}$ D.

Countersunk rivets (fig. 222)—

The countersink should be at an angle of 60°, and in any case the countersinking should not extend beyond $\frac{1}{4}$ of the thickness of the plate.

Diameter of rivet = D,
 Depth of countersink = .5 D,
 Extreme diameter of head = 1.52 D.

Pan-headed or cheese-headed rivets (fig. 223)—

Diameter of rivet = D,
 Depth of head = .45 D,
 Diameter of head = 1.5 D.

The shank of the rivet is parallel or slightly tapering towards

the point; its diameter being slightly less than the hole into which it is inserted.

278. Method of Forming the Rivet-Head.—The process of rivetting consists in heating the rivet, if a short one, to a uniform heat all over in a furnace; if a long one, it will only be necessary to heat the point to a white heat, the body of the rivet being heated to a lower temperature; the rivet is then inserted in the hole and a second head is formed, usually of the same shape as the first, at its point. This second head is formed either by hammering by hand, or by the application of mechanical force. In the process of forming this second head, the shank of the rivet is swelled out so that it completely fills the hole; when a rivetted member of a structure, therefore, is subjected to a direct compressive stress, as far as its strength is concerned, it may be considered as one solid piece, the shank of the rivet replacing the material which has been punched or drilled out of the member. For this reason it is usual, in considering the strength of the compressive members of a structure, to take the gross sectional area as effective, no deduction being made for the holes when the rivetting is properly done.

The length of the shank which projects through the plate necessary to form the head depends (1) on the thickness through which the rivet passes, (2) on the diameter of the rivet, and (3) on the method by which the head is formed—*i.e.*, by hand or by machine.

The longer the rivet, the more material is taken up in filling the hole, and consequently the greater will be the length required for forming the head; also the larger the diameter of the rivet, the greater must be the length of shank required to form the head. It is also found that more material is required to form the head when made by a machine than by hand.

Fig. 225 gives the proportion for a snap-headed rivet 1 inch in diameter passing through two $\frac{1}{2}$ -inch plates. In this example $1\frac{1}{4}$ inch is the length of shank usual to allow in order to form the head when made by hand, and $1\frac{3}{8}$ to $1\frac{1}{2}$ inch when made by machine. If the rivet be $\frac{3}{4}$ inch in diameter, $1\frac{1}{8}$ inch and $1\frac{1}{4}$ inch respectively are sufficient; and for $\frac{1}{2}$ -inch rivets, 1 inch and $1\frac{1}{8}$ inch. If the rivet pass through four plates instead of two, it will be necessary to add $\frac{1}{8}$ inch to the above dimensions. In order to form a countersunk head, an allowance of shank equal to about the diameter

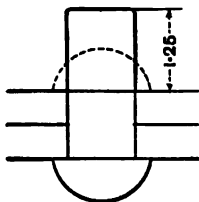

Fig. 225.

of the rivet is what is usually allowed.

It must be borne in mind that the above proportions are given to indicate the general practice, and are not to be considered in the light of hard and fast rules. Cases may arise when a slight modification will be advisable.

279. Rivetting by Hand.—In hand-rivetting the service of three men are required, one to hold the rivet in its place by means of a holder-up, while the other two form the head by hammering alternately.

In order to form conical or countersunk heads, hammers alone are necessary, but for cup-heads a cup-shaped die, usually termed a "snap," is used to give the head the required form. In addition to the three men, the services of a lad are required to heat the rivets in the furnace and to bring them to the work as required. The cost of hand-rivetting varies in different localities; the average price in England at present being about one shilling and sixpence per score for $\frac{3}{4}$ -inch rivets, those of larger diameter being a little more and of smaller a little less.

280. Machine Rivetting—Steam Rivetters—Mechanical Rivetters.—In machine rivetting, the rivet is placed between two dies, the first head resting in one die, while the other die is pressed down on the free end, and thus forms the second head. The older forms of rivetting machines were driven by steam acting through the medium of a piston on the end of a plunger which gave a sudden blow to the rivet. The pressure exerted on the rivet by this machine is equal to the area of the piston in square inches multiplied by the steam pressure per square inch. Steam rivetters in time became superseded by mechanical rivetters, the ram in these machines being worked backwards and forwards by means of an eccentric shaft, the machine being driven by a strap. By these machines the pressure applied in forming the head, is more gradual than in steam rivetters, but the pressure cannot be varied or readily ascertained. For this reason they are not suitable for the best class of boiler-work, but for ordinary girder-work they answer very well.

281. Hydraulic Rivetters.—The next development in power-rivetting was the introduction of hydraulic rivetters, and for many years this system, especially for boiler-work, has been gradually superseding the older methods. The advantages of this system are that the pressure on the rivet is applied gradually, and also the exact pressure can be ascertained and varied at pleasure. By this method also small portable rivetting machines may be used, and instead of bringing the work to the machine as is the case with fixed rivetters, the machine may be taken to the work. This is very advantageous in erecting large bridges

and similar structures *in situ*. The hydraulic pressure is conveyed to the machine by strong metal pipes with elbow joints, the pressure varying from 1000 lbs. to 1750 lbs. per square inch. Some of the objections to this system are that owing to the great pressure used there is generally a leakage at the joints; in cold weather also, there is a danger of the water being frozen. The cost also is considerable, as in addition to the machines themselves, there are the pumps and accumulators which are rather expensive.

282. Pneumatic Rivetters.—The most recent system of power rivetting is that in which pneumatic pressure is the motive power. This method, patented by Mr. Allen of New York, has been in general use in America for some years; it has only been quite recently introduced into this country, and so far as its application to portable machines is concerned, it bids fair to establish itself as a favourite. In Mr. Allen's system the air is pumped into a wrought-iron or steel receiver until a pressure of about 80 lbs. per square inch is obtained; this pressure being sufficient for economically working the machines. The compressed air is taken to the machines by flexible tubes, and acts directly on the piston, which latter usually varies from 8 to 12 inches in diameter, according to the power required. The piston rod is connected to the plunger by a system of levers, by means of which the power is multiplied, so that the pressure on the ram varies, being a minimum at the commencement of its stroke and a maximum at its finish.

This system of rivetting is perhaps the best of all when applied to portable machines; the compressed air, on account of its comparatively low pressure, being much more conveniently distributed than water, and also there is no risk of its freezing, which is an advantage in exposed situations in cold weather. The cost also is not so great as that for a hydraulic plant.

283. Pressure Required to Form the Rivet-Head.—The amount of pressure on the plunger necessary to form a rivet-head depends very largely on the extent to which the rivet is heated; it depends also on the material of which it is made and on its diameter.

With wrought-iron rivets $\frac{3}{4}$ inch in diameter, and heated to a red heat, from 20 to 30 tons is quite sufficient, while with 1-inch rivets 45 tons will be necessary.

With rivets made of mild steel, the pressure required will not be much more, but with hard steel it will be 50 or 100 per cent. in excess.

Rivetting as done by the machine is far better than that done

by hand; the pressure being so much greater and more equable, the different layers of plates are closely pressed together, and the rivet is made to fill the hole much more effectively than if manual labour be employed.

Hand rivetting is similar in its mechanical effect to a small weight falling on the rivet-head a great number of times; this mainly affects the particles at the end of the rivet. On the other hand, machine rivetting resembles a heavy weight falling on the rivet, but with a less velocity, and transmits its effect to the whole body of the rivet. Not only is the work better done by the machine, but it is done much more quickly and economically. Rivets which cost one shilling and sixpence per score when put in by hand will only cost from fifteen to twenty shillings per thousand when put in by machine.

The advantages of machine rivetting being so patent, there is little doubt that hand rivetting would be dispensed with altogether if it were not for the fact that it is impossible or inconvenient to get a machine into cramped and other situations; in such cases hand rivetting must be resorted to. Further, when a bridge or other structure is being erected in an out of the way locality, it will not always pay to transport a rivetting plant to the site.

284. **Strength of Rivets put in by Different Machines.**—Messrs. Greig & Eyth made some experiments with the object of determining the shearing resistances of rivets put in by different machines. Three strips were connected together by a rivet, so that it was in double shear. It appeared that the strength of the rivet was greatest when the joint was made by the machines which worked with the greatest pressure.

With steel rivets $\frac{3}{8}$ inch diameter in $\frac{1}{2}$ -inch drilled holes, the pressure on the rivet and the shearing stress were as follows:—

TABLE XCI.

	Pressure on Rivet in Tons.	Shearing Resistance in Tons per Sq. Inch.
Steam Rivetter, . . .	37	25.74
Stationary Hydraulic Rivetter, .	39	23.80
Portable ,, ,,	20	22.78
Power Rivetter—Light, . . .	31	22.5
,, Heavy, . . .	52	23.76

CHAPTER XXIII.

BRIDGES.

WORKING LOADS AND STRESSES.

285. Definition.—Bridges are structures designed for the purpose of carrying roads over rivers, ravines, or other roads. They may be made of stone, wood, iron, or steel, and may be in one or more spans. Under this heading are also generally included, *Viaducts, Aqueducts, and Culverts.*

Viaducts are structures similar to bridges, but they always consist of more than one span, usually several; and their object, to a large extent, is to save the expense of forming a high embankment in order to carry the road at the requisite level.

An aqueduct is a structure similar to a viaduct, but instead of carrying a road it is designed for conveying water.

A culvert is a kind of drain, its object being to allow water to

Cantilevers.

Fig. 226.

Cantilevers with Central Girder.

Fig. 227.

pass a road, &c. Culverts are usually constructed of brick or stone, and their consideration does not fall within the scope of this work.

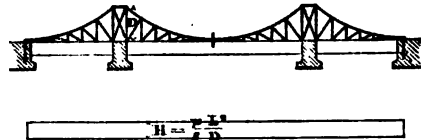
Simple types of bridges are *Girder Bridges*, *Cantilever Bridges*, *Arched Bridges*, *Suspension Bridges*, &c., while complex types consist of a combination of two or more of these elementary forms.

Fig. 226, which is a simple cantilever bridge, is an example of the first type, while fig. 227, which is a combination of cantilevers and girders, is an example of the second type.

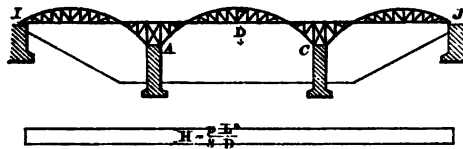
286. Substructure and Superstructure.—A bridge may be divided into two main parts—

1. The substructure ;
2. The superstructure.

The *substructure* comprises the abutments and piers, including their foundations. The abutments are the end supports, and are usually built of stone or brick. The piers are the intermediate supports, and may be of brick, stone, or iron.

A bridge of one span has no piers, and all bridges have two abutments.

The *superstructure* of a bridge consists of the top portion, including the roadway, girders, arches, chains, bracings, &c.; in fact, everything in the bridge with the exception of the abutments and piers.

The relative importance of the substructure and superstructure mainly depends on the nature of the site.

287. Particulars Requisite for designing a Bridge.—As a rule, the object of the engineer in designing a bridge ought to be to make it as cheap as possible consistent with its utility and general appearance. The cost of the superstructure increases with the length of the spans ; therefore, so far as the superstructure is concerned, economy is best attained by increasing their number and diminishing their lengths. On the other hand, the greater the number of spans, the greater the number of the piers, and consequently the cost of the substructure ; it is necessary, therefore, to determine which is the best combination for each particular case. If the piers are high and the foundations bad, or if they occur in a river or arm of the sea where the water is deep and the current swift, they become an expensive item, and the fewer there are the better.

In the case of navigable rivers, another consideration must be taken into account. It is important that the height of the superstructure above the water and the position of the piers be such that the river traffic is not interfered with. Frequently the former desideratum cannot be obtained without great cost. It may be necessary to make one span of the bridge movable, so

that it can be opened to allow vessels to pass. All these considerations have to be taken into account in making the design, and if possible, the engineer should visit the site and examine the nature of the foundations by borings or otherwise. When this is not possible, as in the case of bridges to be erected abroad, the following among other particulars should be supplied :—

1. A complete section of the site, showing the length of the proposed bridge and the levels of the approach roads.

2. Information as to the nature of the ground and its suitability for foundations; this is especially necessary when the bridge has to cross a river where piers may be required. The nature of the bed of the river should be ascertained by borings, and the existence of rock, gravel, sand, clay, and boulders should be shown on the section.

3. The highest and lowest levels of the water should also be indicated, and the clear headway required for passing vessels.

4. If the bridge is for ordinary road traffic, the required width of the roadway and footpaths should be indicated; also the kind of roadway required, whether timber, macadam, or stone pavement.

5. The kind of traffic liable to come on the bridge should be specified, more particularly the heaviest loads which may pass over it. It is also necessary to know the distance apart and the number of wheels of the vehicles which convey these loads. This information is specially useful for determining the loads on the cross girders and road bearers, which are exposed to heavy concentrated weights.

6. If the bridge is for the purpose of carrying a railway, it should be stated whether a single or double line is required, also the gauge of the rails. The weight of the heaviest engine and how the weight is distributed on the wheels should be stated, and also the weight per lineal foot of loaded trucks and carriages.

7. Information should also be given of the means of conveying the bridge to the site; the nature of the roads, &c., leading to it. In case scaffolding be required to erect the bridge, information should be had as to the facilities for obtaining this in the neighbourhood.

Information under this last head is often of the greatest consequence. Some sites are so inaccessible, that the cost of getting the bridge there, may be more than the cost of the bridge itself. In such cases the design must be so arranged that no part must exceed a certain weight and certain dimensions. Cases sometimes occur where skilled labour cannot be procured in the locality, and where it may be expensive to send suitable

men. Under such circumstances arrangements should be made so that the work to be done on the site be as simple as possible.

288. Dimensions of Bridges.—There are certain minimum main dimensions, such as the width and height, of public road bridges which are fixed by the Governments of different countries. In this country, for example, for *Over Bridges*, or bridges which carry a road over a railway, the width between the parapets for a turnpike road should be at least 35 feet, except in special cases where the road at either end of the bridge is narrower, when the width may be less, but in no case to be under 30 feet.

For public roads, other than turnpike, the width between the parapets should not be less than 25 feet, except in special cases similar to those mentioned for turnpike roads, when the minimum width may be 20 feet. The minimum width for private roads is 12 feet.

The minimum height of the lowest portion of an over bridge above the rail-level is 14 feet 6 inches.

In *Under Bridges*, or those which carry a railway over a road, the widths for the different kinds of roads, or what is the same thing, the spans, taken on the square, of the bridges, should be the same as stated for over bridges.

The minimum head room for turnpike roads should be 12 feet at the springing of the arch—if an arched bridge—and 16 feet for a breadth of 12 feet in the middle. For other public roads, these dimensions should be 12 feet, 15 feet, and 10 feet respectively.

For private roads, the minimum head room should be 14 feet for 9 feet in the middle.

289. Dimensions relating to Railway Bridges.*—Table XCII., see p. 406.

“Additional width at bottoms of cuttings, from 0 to 9 feet.

“Arches over the railway are seldom made of the minimum spans shown by the table on p. 406, except in the case of tunnels. Bridges over narrow-gauge lines are usually of the following spans :—

Over a single line, from 16 to 18 feet,
Over a double line, from 28 to 30 feet.”

290. Loads on Bridges.—All bridges are exposed to two kinds of vertical loads which should be considered separately, viz. :—

1. The dead load,
2. The live load.

* Rankine's *Useful Rules and Tables*, p. 142.

TABLE XCII.

	Narrow Gauge.	Irish Gauge.	Broad Gauge.
SINGLE LINE.			
Clear space outside of rail,	Ft. Ins. 4 0	Ft. Ins. 4 0	Ft. Ins. 4 0
Head of rail,	0 2½	0 2½	0 2½
Gauge,	4 8½	5 3	7 0
Head of rail,	0 2½	0 2½	0 2½
Clear space outside of rail,	4 0	4 0	4 0
Least breadth of top of ballast, and least width admissible for archways, &c., traversed by the railway,)	13 1½	13 8	15 5
Spaces for slopes of ballast, and benches beyond them, on embankments,) from to	3 10½ } 8 10½ }	4 4	9 2
Total breadth of top of embankments,) from to	17 0 } 22 0 }	18 0	24 7
DOUBLE LINE.			
Clear space outside of rail,	4 0	4 0	4 0
Head of rail,	0 2½	0 2½	0 2½
Gauge,	4 8½	5 3	7 0
Head of rail,	0 2½	0 2½	0 2½
Middle space (called the "six feet"),	6 0	6 0	6 0
Head of rail,	0 2½	0 2½	0 2½
Gauge,	4 8½	5 3	7 0
Head of rail,	0 2½	0 2½	0 2½
Clear space outside of rail,	4 0	4 0	4 0
Least breadth of top ballast, and least width admissible for archways, &c., traversed by the railway,)	24 3	25 4	28 10
Spaces for slopes of ballast, and trenches beyond them on embankments,) from to	3 9 } 8 9 }	4 8	9 2
Total breadth of top of embankments,) from to	28 0 } 33 0 }	30 0	38 0

291. Dead Load.—The dead load on a bridge consists of the weight of the superstructure, and is constant for each bridge, and, therefore, produces a constant stress either of compression or tension on each member. It consists of—

1. The roadway,
2. The platform,
3. The main girders.

The roadway may be of wood, macadam, brickwork, stone setts, asphalt, or iron, or a combination of two or more of these.

The roadway is practically uniformly distributed over the whole surface of the platform. The following table gives the weights of the materials most commonly used for the roadways of bridges :—

TABLE XCIII.

Material.	Weight in lbs. per cubic foot.
Pine,	30 to 42
Oak,	50 to 60
Creosoted pine timber,	42 to 48
Granite,	165
Limestone,	160
Sandstone,	155
Asphalte,	150
Brickwork,	96 to 112
Concrete,	120 to 135
Sand,	100 to 120
Macadam (compressed),	120

292. Live Load upon Public Road Bridges.—The greatest distributed live load that can come on a public road bridge is that produced by a crowd of people closely packed over its whole surface. The estimated weight of such a crowd varies considerably ; some engineers consider 80 lbs. per square foot sufficient, while others give very much higher estimates. Mr. Stoney packed 58 Irish labourers, weighing 8,404 lbs., into a space of 57 square feet ; this is equivalent to 147.4 lbs. per square foot. It is, however, scarcely possible that such crowding could take place on a bridge. If 1 cwt. per square foot be taken to represent the maximum load it will be quite sufficient. A body of men marching with regular step over a bridge is very trying to it, especially if it be of the suspension type. It is the opinion of some engineers that the stresses produced on some forms of bridges by such a moving load are at least twice as great as those

produced by the same load in a state of rest; but then it must be remembered that the actual weight of marching troops per square foot is not nearly so great as that of a stationary crowd; in fact, it does not exceed 40 lbs. per square foot.

Public road bridges are subject to other loads besides a crowd of people; and though in the aggregate they do not equal 1 cwt. per square foot of roadway area, yet at certain points their intensity is very much greater, and they may produce very great local stresses. For example, a traction engine or a 4-wheeled vehicle carrying a heavy boiler, &c., may produce pressures as great as 10 tons on each wheel, or 20 tons on a pair of wheels. A single cross-girder may thus have to support as much as 20 tons from the passing load, whereas the weight coming on it from a crowd of people would be very much less. A heavy rolling load of this kind would also produce great shearing stress towards the centres of the main girders which would not be produced by a uniformly distributed load. From this it will be seen that, in order to find the maximum stresses on the different parts of a road bridge, it will be necessary to calculate the stresses both from the maximum distributed load and the maximum rolling load, taken separately. If the main girders be of the lattice type, a heavy concentrated rolling load will produce stresses of *different* kinds, viz., those of compression and tension, in the braces towards the centres of the girders, according to its position on the bridge, so that it will be necessary to counter-brace these central lattices (see pp. 273, 276).

293. **Live Load on Railway Bridges.**—The maximum rolling load coming on a railway bridge, consists of a string of locomotives coupled together so as to cover the bridge. The weights of locomotives are very much greater now than formerly, and the limit does not yet seem to be reached. The maximum load on a cross-girder occurs when a pair of driving wheels rests upon it, or two pairs in a double line of railway.

Table XCIV. shows the average distribution of the weights of a six-wheeled locomotive on its wheels,* assuming the total weight of the engine in working order to be 1.

A string of locomotives coupled together will weigh from 1 ton to $1\frac{1}{2}$ tons per lineal foot. A train of loaded cars will weigh from $\frac{1}{2}$ ton to $\frac{3}{4}$ ton per lineal foot. The live load per lineal foot to be allowed for in railway bridges varies with the span. An engine weighing 40 tons may not have a greater wheel base than 16 feet, so that a bridge of 16 feet span, may have a load

* *Molesworth.*

of 40 tons for each pair of rails resting upon it, or $2\frac{1}{2}$ tons per foot. As the span increases, the weight per foot decreases, so that in bridges of 100 feet span, the weight per foot on each line will not exceed $1\frac{1}{2}$ tons. For spans of 400 feet, the load will be rather less than 1 ton.

TABLE XCIV.

	Passenger Engines.	Goods Engines.
Load on leading wheels, . . .	0·32	0·34
„ driving wheels, . . .	0·48	0·36
„ trailing wheels, . . .	0·20	0·30
Total weight of engine, . . .	1·00	1·00
Passenger engines, 4 ft. 8½ in. gauge,		
average weight,	from 30 to 35 tons,	
Goods engines,	„ 35 to 40 „	
Mètre gauge,	„ 18 to 20 „	

Mr. B. Baker gives the following loads for modern engines :—

TABLE XCV.—LIVE LOAD IN TONS FOR SINGLE LINE.

For 10 feet spans, rolling load = 3·00 tons per foot.

„ 20	„	„	2·40	„
„ 30	„	„	2·10	„
„ 60	„	„	1·50	„
„ 100	„	„	1·375	„
„ 150	„	„	1·25	„
„ 200	„	„	1·125	„
„ 300	„	„	1·00	„

Table XCVI. gives the maximum rolling loads for different spans allowed by one of the large English railway companies.

TABLE XCVI.—MAXIMUM ROLLING LOADS ON RAILWAY BRIDGES OF DIFFERENT SPANS.

Span in Feet.	Rolling Load in Tons Distributed for each Pair of Rails.	Span in Feet.	Rolling Load in Tons Distributed for each Pair of Rails.	Span in Feet.	Rolling Load in Tons Distributed for each Pair of Rails.	Span in Feet.	Rolling Load in Tons Distributed for each Pair of Rails.
10	32	33	62	56	85	79	118
11	33	34	63	57	87	80	120
12	34	35	64	58	88	81	121
13	36	36	65	59	90	82	123
14	38	37	66	60	91	83	124
15	40	38	67	61	93	84	125
16	42	39	68	62	94	85	127
17	45	40	69	63	96	86	128
18	47	41	70	64	97	87	129
19	48	42	71	65	98	88	130
20	50	43	72	66	99	89	132
21	51	44	73	67	101	90	133
22	53	45	74	68	102	91	134
23	54	46	75	69	104	92	136
24	55	47	76	70	105	93	137
25	56	48	77	71	106	94	138
26	57	49	78	72	108	95	140
27	57	50	79	73	109	96	141
28	58	51	80	74	111	97	143
29	59	52	81	75	112	98	144
30	59	53	82	76	114	99	145
31	60	54	83	77	115	100	147
32	61	55	84	78	117		

Mr. Stoney, in the last edition of his work, gives the following table, which he recommends for lines where the heaviest engines are used. It will be noticed that these loads are considerably in excess of those recommended by Mr. Baker:—

TABLE XCVII.—STANDARD ROLLING LOAD ON RAILWAY BRIDGES.

Length of Girder.	Standard train load per foot of each line.	Length of Girder.	Standard train load per foot of each line.
Feet.	Tons.	Feet.	Tons.
400	1·25	100 to 40	2·0
350	1·37	35	2·5
300	1·50	30	3·0
250	1·62	25	3·5
200	1·75	20	4·0
150	1·87	15	4·5
		10	5·0

The loads given in the preceding tables are applicable only to fix the strengths of the main girders. Other portions of the bridge, such as the cross-girders and rail-bearers, are exposed to local loads which have to be considered independently. For a single line, each cross-girder, as has been stated, is exposed to the weight of a pair of driving wheels, which in heavy engines may amount to 20 tons. A rail-bearer is liable to have one driving wheel resting on its centre, the weight from which may be as much as 10 tons, and its strength must be proportioned accordingly.

294. *Effect of Loads in Rapid Motion.*—Loads in rapid motion, such as railway trains, in passing over a bridge produce greater stresses on the structure than equal loads at rest. This factor, however, does not seem to be sufficiently great to be taken into consideration, except in bridges of small span. Commissioners were appointed to investigate this subject, and they made a careful series of experiments by passing loads at different velocities over bars and observing the deflection. Thus, for example, “when the carriage loaded to 1120 lbs. was placed at

rest upon a pair of cast-iron bars, 9 feet long, 4 inches broad, and $1\frac{1}{2}$ inches deep, it produced a deflection of $\frac{6}{10}$ ths of an inch; but when the carriage was caused to pass over the bars at the rate of 10 miles an hour, the deflection was increased to $\frac{8}{10}$ ths, and went on increasing as the velocity was increased, so that at 30 miles per hour, the deflection became $1\frac{1}{2}$ inches; that is, more than double the statical deflection." Since the velocity so greatly increases the effect of a single load in deflecting the bars, it follows that a much less load will break the bar when in motion than when at rest. In the example above selected, a weight of 4150 lbs. is required to break the bars if placed upon their centre; but a weight of 1778 lbs. is sufficient to produce fracture if passed over them at the rate of 30 miles an hour.

The increase in the deflection of railway bridges owing to the rapid motion of a train is practically very small, except in the case of small spans. Mr. Stoney found that "the difference of deflection caused by a locomotive crossing the central span of the Boyne Viaduct, 264 feet in the clear between the supports, at a very slow speed, and at 50 miles an hour, was scarcely perceptible, and did not exceed the width of a very fine pencil stroke;" but the increase of deflection is more marked in bridges of small span, as appears from the following experiments made on the Godstone Bridge, South Eastern Railway, by the Commissioners appointed to inquire into the application of iron to railway structures. The Godstone is a cast-iron girder bridge 30 feet span, with two lines of railway.

Weight of two girders,	15 tons
„ platform between these girders, 10 „	—
„ half the bridge, <i>i.e.</i> , dead load, 25 „	—
Weight of engine,	21 tons.
„ tender,	12 „
„	—
Moving load,	33 „

Velocity in Feet per Second.	Deflection in Inches.
0	·19
22 = 15 miles per hour.	·23
40 = 27·3 „ „	·22
73 = 49·8 „ „	·25

The conclusions arrived at by the Commissioners were as follows :—

“That as it has appeared that the effect of velocity communicated to a load is to increase the deflection that it would produce if set at rest upon the bridge ; also that the dynamical increase in bridges of less than 40 feet in length is of sufficient importance to demand attention, and may even for lengths of 20 feet become more than one-half of the statical deflection at high velocities, but can be diminished by increasing the stiffness of the bridge ; it is advisable that, for short bridges especially, the increased deflection should be calculated from the greatest load and highest velocity to which the bridge may be liable ; and that a weight which would statically produce the same deflection should, in estimating the strength of the structure be considered as the greatest load to which the bridge is subject.”

295. *Side Pressure on Bridges.*—There are two motive forces which may produce a horizontal side pressure on bridges, viz., *wind-pressure* and *centrifugal force*. These forces may play an important part in bridges of long span, not only on the super-structure, but also on the piers if these latter are high, an example of which occurred in the first Tay Bridge, the piers of which failed owing to the wind-pressure. As the subject of wind-pressure has been treated of elsewhere (see Chap. XXIX.) it will not be necessary to refer further to it here.

296. *Centrifugal Force.*—When the rails on a railway bridge form a curve, a centrifugal force is produced by a passing train which, though modified by raising the rail on the outer curve, cannot altogether be eliminated. Theoretically this force varies *directly* as the weight of the train, and as the square of the velocity at which it travels, and *inversely* as the radius of the curve.

If W = weight of the train in tons,
 v = its velocity in feet per second,
 r = radius of curvature of the rails in feet,
 g = 32, the force of gravity,
 P = centrifugal force in tons,

$$\text{Then } P = \frac{W}{g} \cdot \frac{v^2}{r} \quad . \quad . \quad . \quad (1).$$

Example 1.—If an engine weighing 40 tons pass over a curve on a bridge with a velocity of 60 miles an hour, what will be the side pressure exerted on the bridge when the radius of the curve = 1000 feet and both rails are at the same level ?

Sixty miles an hour is equivalent to 88 feet per second. We have, therefore,

$$W = 40, \quad v = 88, \quad r = 1000, \quad g = 32.$$

Substituting in equation (1) we get—

$$P = \frac{40}{32} \times \frac{(88)^2}{1000} = 9.7 \text{ tons.}$$

297. Longitudinal Stresses on Bridges.—In these days of continuous railway brakes, when the motion of a train can be suddenly retarded by the application of the brakes, a very great longitudinal stress is communicated to the rails, and which through them is transmitted to the bridge. This may become serious in bridges resting on high piers.

If the girders are secured to the piers as is frequently the case, and the ends resting on the abutments be allowed to slide, it is evident that the longitudinal stress produced by the retardation of the train is communicated directly to the pier or piers, converting them into cantilevers loaded at the free end.

Mr. Baker, in a discussion on the Jubilee bridge erected in India,* said, "Longitudinal stress from brakes is an extremely important element in the design of viaducts at the present day. Last Autumn some experiments were made on the West Shore railroad with the Westinghouse brake fitted to a train of American box cars, each weighing 20 American tons light, and 50 tons loaded, with a length of 38 feet 4 inches. That comes to very much the same thing as a continuous string of locomotives, and the experimental train consisted of fifty of these cars. From the rate at which the train pulled up when the brakes were applied it might at once be deduced that the retarding force must have been $\frac{1}{4}$ th of the weight. That would mean that a similar train over the Hooghly Bridge with the brakes on would produce a longitudinal shove of 200 tons. Now 200 tons acting on the top of these piers 33 feet high meant a bending moment of 6,600 tons. In many cases this would be sufficient to bring the bridge down. . . . The old Tay Bridge with five continuous spans of over 200 feet, fixed only at one pier and at rollers on the others, might have gone down any fine afternoon from this cause, if it were not held by the rails of the permanent way which had no expansion joints."

298. Working Stresses on Bridges.—There are two kinds of working stresses to which the members of a bridge may be exposed, viz :—

* *Min. of Pro. Inst. of C.E.*, vol. 92.

1st. *The permanent working stress*, which is due to the dead weight of the structure itself, and which is permanent and constant.

2nd. *The maximum working stress*, which takes place when the maximum live load passes over the bridge. Usually when the working stress is mentioned, the latter is understood; and the working stress on any member of a structure may be defined to be the maximum stress per square inch of sectional area to which the member may be exposed.

The question as to what ought to be the safe working stress allowed for in different materials is not in a very satisfactory condition (see Arts. 19 and 20). Up to the present it has been determined by dividing the ultimate strength of the material by a certain number, which is called *the factor of safety*; and the stress thus determined has generally been applied to all cases alike, whether the stress be produced by a fixed or by a moving load. This practice is open to objections. It is not so much the ultimate strength of the material which ought to form a basis for fixing the working stress, as *its limit of elasticity*, and this is the best criterion for determining the working stress. If the ultimate strength be taken as a basis, it should only be done so in conjunction with the limit of elasticity. At present both of these are recognised by engineers.

299. *Working Stress on Cast-Iron Bridges.*—Cast iron, like other materials, behaves differently when subjected to a statical load and to a moving load.

The commissioners appointed to inquire into the application of iron to railway structures, found that, when a bar of cast iron was subjected to long-continued impacts, "The general result obtained was, that when the blow was powerful enough to bend the bars through one-half of their ultimate deflection (that is to say, the deflection which corresponds to their fracture by dead pressure), no bar was able to stand 4,000 of such blows in succession; but all the bars (when sound) resisted the effects of 4,000 blows, each bending them through one-third of their ultimate deflection."

From another series of experiments they found "That when the depression was equal to one-third of the ultimate deflection, the bars were not weakened. This was ascertained by breaking them in the usual manner with stationary loads in the centre. When, however, the depressions were made equal to one-half of the ultimate deflection, the bars were actually broken by less than nine hundred depressions. . . . It may on the whole, therefore, be said, that, so far as the effects of reiterated flexure

are concerned, cast-iron beams should be so proportioned as scarcely to suffer a deflection of one-third of their ultimate deflection. . . . It follows that to allow the greatest load to be one-sixth of the breaking weight is hardly a sufficient limit for safety, even upon the supposition that the beam is perfectly sound."

As a general rule, one-sixth of the breaking weight may be taken as the safe working stress for cast-iron girders in bridges, while those that are employed to support constant steady loads, one-fourth of the breaking stress may be considered safe.

The Board of Trade, in its regulations with regard to the working stresses on cast-iron girders in railway bridges, very properly recognises a difference between the dead and rolling loads on such structures, and its rule is—"*In a cast-iron bridge the breaking weight of the girders should not be less than three times the permanent load due to the weight of the superstructure, added to six times the greatest moving load that can be brought on it.*"

In railway bridges it is best not to expose the cast iron in tension to more than one-sixth of its ultimate strength, which in fairly good iron will be from $1\frac{1}{2}$ to $1\frac{1}{4}$ tons per square inch. In those parts exposed to compression, 6 tons may be allowed.

The working stresses allowed by the French Government are very much less, viz., about 0.63 tons in tension, and 3.17 tons in compression.

Engineers in their specifications usually stipulate that test bars of cast iron, when supported at the ends, must carry a certain weight at the centre. A common test clause is that rectangular bars, 2" x 1", placed edge-ways on bearings 3 feet apart, shall support a weight of 25 cwts. suspended from the centre. Another common specified test is that bars, 1" x 1", placed on bearings 4 feet 6 inches apart shall support, without fracture, a weight of 550 lbs. hung from the centre. It is also usually directed that one or more of the test bars shall be run from each heat of metal. There is no difficulty in procuring iron to stand these tests.

When cast-iron pillars rest on masonry foundations, for good work it is specified that the bases be faced in the lathe. If a pillar or pile be made of different lengths bolted together, the abutting surfaces at the joints should be faced. Some engineers further specify that, in addition to facing the abutting surfaces, layers of sheet lead be inserted between them; but this precaution, except in special circumstances, is superfluous. When cast-iron girders rest on masonry, or bearing plates, or other girders, it is usual to specify that a layer of sheet lead or one or more

layers of felt be placed between the bearing surfaces. When a cast-iron arch is made up of different segments bolted together, the abutting surfaces should be faced and a layer of lead inserted between them.

300. Working Stresses on Wrought-Iron Bridges.—The Board of Trade Rule for the working stresses allowed to come on wrought-iron bridges is :—“ *In a wrought-iron bridge the greatest load which can be brought upon it, added to the weight of the super-structure, should not produce a greater stress on any part of the material than 5 tons per square inch.*”

Engineers do not take full advantage of this rule in designing bridges ; the limit of 5 tons is only applied to those parts of the structure exposed to tension, those members in compression not being strained to the same extent. The top flanges of girders, for example, as a rule are only exposed to a maximum of 4 tons, while the struts in lattice girders, &c., are subjected to stresses which vary with the ratio of the length of the strut to its diameter, and also according to the manner in which the ends are fastened, as explained in Chap. XI. The stress of 5 tons on those members in tension is computed on the net sectional area only, the area of the rivet holes being deducted from the gross section. The stress on the compression members is usually computed on the gross sectional area, as the holes are supposed to be completely filled up by the rivets. This method of applying the working stresses has the effect of making the top and bottom flanges of a girder nearly equal in section, the compression flange being slightly greater.

These rules for determining the working stresses on wrought-iron bridges, though generally adopted in this country, cannot be said to be altogether satisfactory. Wrought iron, like cast iron, when exposed to vibrations, and variations of stress, is likely to become more deteriorated in time, than when it is exposed to only a constant and steady stress ; and, such being the case, it is only natural that this fact should be recognised in designing structures.

This may be done in two ways :—

1. The flanges of main girders, especially those of large span which are not so susceptible to vibrations and variations of stress, may be exposed to 5 tons in tension and 4 tons in compression, as already explained ; while those of the cross-girders, especially in railway bridges which are more exposed to vibrations and changes of stress from passing loads, should not be exposed to more than 3 tons in compression and 4 tons in tension. This difference of working stress between the main and cross-girders

of railway bridges is recognised by American engineers. It is also advisable in some cases not to expose the lattice-bars of the main girders to more than 4 tons in tension.

2. Two working stresses might be employed, one (for the dead load) of say 5 tons for tension and 4 tons for compression, and another (for the live load) of say 4 tons for tension and 3 tons for compression. This seems a very good practice to adopt in designing railway bridges, but so long as it is not recognised by the Board of Trade or other Official Authorities, it is not likely to be generally adopted.

The French rule for wrought-iron railway bridges is that *in no part shall the working stress either of tension or compression exceed 3·8 tons per square inch of gross section.*

301. Shearing Stresses on the Webs of Wrought-Iron Girders.—

In wrought-iron girders with continuous plate webs, there is no definite rule as to what working shearing stress should be applied to the webs; a great deal depends on whether the webs are properly stiffened. When this is done it is not usual to subject them to a greater working stress than 3 or $3\frac{1}{2}$ tons per square inch of net sectional area, especially in railway bridges, for the cross-girders and rail-bearers the stress should be rather less.

In wrought-iron bridges there is always a certain amount of corrosion going on which in time materially affects the strength of the structure. This deterioration largely affects the web, which, in proportion to its weight, exposes a large surface to the atmosphere. For this reason it is advisable to have a good margin of strength in the webs.

All the foregoing working stresses are based on the assumption that the iron is of ordinary quality with an ultimate tensile strength of at least 20 tons to the inch. With special brands, it is allowable to increase somewhat the working stresses, although the Board of Trade does not recognise any distinction.

302. Working Stresses on Steel Bridges.—

Mild steel has of late years come very much to the front as a material for bridge-construction, and it is not at all unlikely that, in the future, it may altogether supersede wrought iron. The working stresses applicable to this material are not so clearly defined as in wrought iron. This is owing to the fact that, being a new material, its strength under different conditions of loading has not been exhaustively proved. The Board of Trade rules prohibit, except in special cases, a greater working stress than $6\frac{1}{2}$ tons; this, compared with 5 tons on wrought iron, means only an increase of about 30 per cent. This working stress is very safe considering that, at the present day, reliable steel can

be produced with a tensile strength of 30 tons, and a limit of elasticity of about 18 tons. So long as the Board of Trade adhere rigidly to their rule, the use of steel for public bridges will not be extensive. In the Forth Bridge, where the steel conformed to certain stipulated tests, the Board of Trade relaxed their rule and allowed a working stress of $7\frac{1}{2}$ tons, and it is probable that before long they will make this limit universal.

303. Working Stress on Timber.—Timber is not now much used in this country for permanent structures, it being superseded by iron and steel. For temporary structures, however, it is still largely used in England, while in America and other countries it forms an important material for permanent structures. On account of its perishable nature, especially when exposed to the weather, it is advisable to use a high factor of safety. When under cover the factor of safety for permanent structures should be about 8, but when exposed to the weather it should not be less than 10. American engineers do not, as a rule, allow a greater longitudinal working stress than 800 lbs. per square inch on this material. When timber is used for temporary structures, such as scaffolding, temporary bridges, &c., a working stress equal to one-fourth of the ultimate stress may be allowed.

CHAPTER XXIV.

BRIDGES—*continued.*

FOUNDATIONS AND PIERS.

304. Timber Foundations.—The abutments of bridges are generally built of stone or brickwork, and are made massive, especially when they have to receive the thrust of an arch.

Up to a comparatively recent period the piers of bridges were built of stone, brickwork, or timber, or a combination of these. The use of timber may either be temporary or permanent. In the former capacity it may be used for coffer-dams, and in the latter as foundations upon which to erect the masonry. For this latter purpose timber piles are driven into the ground until a good foundation is reached, their tops are then cut off level, and they are connected together by horizontal beams of

wood, which form a platform upon which the masonry is built. Sometimes the piles are driven so as to form a circle, the space between being filled with concrete. The ends of the piles which go into the ground should be tapered to a point, and if stones or other impediments occur in the strata, the ends should be fitted with shoes of cast or wrought iron.

Timber piles are usually driven by a falling weight, worked either by hand or by a steam engine. In order to prevent the head of the pile being split by the blows of the ram, it should be bound with a wrought-iron hoop. Professor Rankine* says, "According to some of the best authorities, the test of a pile's having been sufficiently driven is, that it shall not be driven more than *one-fifth* of an inch by *thirty blows* of a ram weighing 800 lbs. and falling 5 feet at each blow; that is to say, by a series of blows whose total mechanical energy amounts to

$$"30 \times 800 \times 5 = 120,000 \text{ foot-pounds.}"$$

The same authority says, "It appears from practical examples that the limits of the safe load on piles are as follows:—

"For piles driven till they reach the firm ground, 1000 lbs. per square inch of area of head." (= 64.3 tons per square foot.)

"For piles standing in soft ground by friction, 200 lbs. per square inch of area of head." (= 12.85 tons per square foot.)

"The intensity of the pressure on a rock foundation should at no point exceed one-eighth of the pressure which would crush the rock."

"The greatest intensity of pressure on foundations in firm earth is usually from 2500 to 3500 lbs. per square foot, or from 17 to 23 lbs. per square inch."

305. Cofferdams.—Cofferdams are enclosures used for building foundations in water. They are usually built of timber, and must be made water-tight. As ordinarily constructed, they consist of two main rows of piles and sheet piles, the space between them being filled with clay. The tops of the piles, which must be above high-water mark, are bolted together by cross-beams.

Professor Rankine says:—"The common rule for the thickness of a coffer-dam is to make it equal to the height above ground, if the height does not exceed 10 feet; and for greater heights, to add to 10 feet one-third of the excess of the height above 10 feet."

* Rankine's *Civil Engineering*.

This thickness is not given for the purpose of making the coffer-dam water-tight, as 3 feet is generally sufficient for this purpose, but to give the framework necessary stability.

306. Caissons.—Caissons are water-tight cases sunk in river-beds, or similar positions, and in which masonry or brick piers are built. They serve merely the purpose of coffer-dams, and are usually elliptical in plan and made of wrought-iron or steel plates stiffened with angle or tee rings. They may be removed after the pier is built, or they may remain to form part of the permanent structure; the latter plan being generally adopted as the cost of removal is often great.

The simplest method of sinking caissons is by gravitation. After they have been placed in their proper position in the river-bed, the soil is dredged out from the inside, which allows the caisson to descend by its own weight. It will sometimes be found necessary to place weights on the top to facilitate the descent. After the bottom edge has reached a firm stratum which prevents the ingress of the water, the latter may be pumped out, when workmen can descend to complete the necessary excavation. After a firm foundation has been reached the casing can be filled with concrete or masonry.

Cases frequently occur where this simple method of sinking cannot be employed. The nature of the river-bed may be such that the ingress of water to the caisson cannot be prevented by ordinary means; and it may be necessary to cover over the top of the casing and force air into it at a considerable pressure, by which means the water may be excluded.

307. Iron Piers.—Iron for foundations and piers may be used in a variety of forms, both cast and wrought iron being extensively employed. Cast-iron piers usually consist of screw-piles or cylinders, while wrought iron, as previously explained, may be employed in the form of caissons.

308. Screw-Piles.—Screw-piles are made of different forms and dimensions, according to the nature of the ground they have to pass through and the loads they have to bear. They are usually made of cast iron, and may be solid or hollow, and resemble an ordinary column with a screw fixed at one end. Hollow piles generally vary from 1 foot to 2 feet 6 inches in diameter, and from $\frac{1}{2}$ to $1\frac{1}{2}$ inches in thickness. They are cast in convenient lengths with a flange at each end—except the bottom length—by means of which they may be bolted together. In order to make a good joint, the flanges should be faced, the holes drilled, and the bolts turned; there will then be no play in the holes, and the joint will be better able to resist the torsion to which it is

exposed in the process of screwing. The first length which goes into the ground has the screw-blade cast on it; this latter seldom makes more than a single turn. The diameter of the screw depends on the weight coming on the pile, and on the nature of the ground; it varies from twice to four times that of the pile, and its pitch from one-half to one-fourth of the diameter. It is best to have the flanges cast on the inside of the pile when the diameter is sufficiently large to admit of the bolts being got in; they will not then form an obstruction to the downward passage of the pile through the ground.

Screw-piles are sometimes made of wrought iron or steel, in which case they are often solid and of much smaller diameter, say from 4 to 9 inches; sometimes, though rarely, the screw-blades are made of the same material. Now that steel castings can be made much more reliable and more cheaply than formerly, it is probable that this material will, in the future, be much used for screw-blades.

309. Method of Sinking Screw-Piles.—When a pile is to be inserted in the ground, it is advisable to have a strong framework to hold it in its place and to guide its descent. If it is to be screwed into the bed of a river, there should if possible be a fixed platform for the men to work on; this is much preferable to floating rafts or barges, though the circumstances of the case may sometimes render the latter necessary. A capstan is usually fixed on the top of the pile, there being a key-way in the capstan which fits into a corresponding projection on the pile; with this arrangement the capstan will not descend with the pile.

The capstan may be made to revolve by men or horses working at the extremities of the arms, or when more power is required, a rope or chain may be made to pass round the extremities of the arms, and the ends connected to crabs fixed on the platform or ground. When the pile descends a certain distance, the capstan is removed, another length of pile is bolted on, and the operation repeated. Hollow piles, especially those of large diameter, should be filled with concrete, after they have been sunk; this adds to the strength and stability of the pile and prevents internal corrosion. In large undertakings hydraulic or pneumatic power may with advantage be substituted for animal labour in screwing the piles. Screw-piles are suitable for piers when the ground consists of sand, gravel, clay, alluvial soils and similar strata; they will also penetrate soft rock and even brickwork. But when the strata contains obstacles, like trees and large boulders, they are not

suitable, and their sinking becomes a very troublesome and expensive operation.

Another method of sinking cast-iron piles has been adopted by Mr. Brunlees, and is very suitable for sandy soils, such as are usually to be met with at the sea side. According to this method, the pile is closed at the top, except a small aperture where a tube is inserted, through this tube water is forced by means of a hand pump or similar appliance; as the water rushes down the pile, it forces the sand away from the base, and by giving the pile a horizontal reciprocating motion it gradually descends. When it reaches the required depth, the tube is withdrawn, and the sand consolidates and forms a firm foundation.

310. Piers composed of Screw-Piles.—When a number of screw-piles are sunk close to each other, and suitably braced together, they form a very strong pier. Fig. 228 represents in plan an arrangement adopted in forming the piers of the Crumlin Viaduct, and which has since, with slight modifications, been applied to a number of other viaducts and bridges. Each pier consists of 14 cast-iron piles 12 inches diameter, with a thickness of metal of 1 inch. The two central ones only are vertical, the others tapering inwards towards the top of the pier; they are securely braced together both by cast- and wrought-iron bracings; the longitudinal and transverse horizontal braces being cast iron and the diagonals wrought iron.

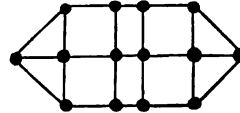

Fig. 228.

In making the connection of wrought-iron braces to cast-iron piles, it is advisable to have a strap of wrought iron fixed round the pile, and the bracing connected to this strap. This is much preferable to the plan, frequently adopted, of making the connection to a lug cast on the pile; this latter plan cannot be recommended unless the lug is made very strong indeed.

311. Cast-Iron Cylinders.—Cast-iron cylinders are very suitable for forming piers in water. They may be 4 feet diameter and upwards, according to the height of the pier, the weight coming on it, and the nature of the strata in which they are sunk. The thickness of metal is usually from 1 inch to $1\frac{1}{4}$ inches. The cylinders are cast in about 5 feet lengths, with inside flanges for bolting the lengths together. It is important that the joints should be made perfectly water-tight, either by facing the edges in contact or by caulking. The bottom edge of the cylinder is usually made thicker than the main body, and is tapered down

to a cutting edge to facilitate its passage through the ground. It is a common practice to have the bottom length of the cylinder of larger diameter than the main body, the two diameters being joined together by a taper length of the form of the frustrum of a cone. By this arrangement an increased bearing area is provided for.

In the process of sinking a cast-iron cylinder a few lengths are bolted together and let down into the bed of the river. The top is always kept above water by adding fresh lengths as it descends. The material inside the cylinder is excavated by means of a digger, and as the material is removed, the cylinder sinks by its own weight, or in some cases additional weight is applied to hasten its descent. This process is carried on until the bottom reaches a stratum of sufficient firmness to form a good foundation. Extra lengths are then added until the top of the cylinder reaches the required height. The cylinder is then filled in with concrete, which gives increased stability to the pier.

Two cylinders at least are required to form a pier—one under each main girder of the bridge, and they are braced together usually with cast-iron bracing.

Cylinders of large diameter are sometimes used as casings in which brickwork or masonry is built; the latter in reality forming the pier. The iron in such cases need only be strong enough to serve as a shell for the masonry.

CHAPTER XXV.

BRIDGES—*continued.*

SUPERSTRUCTURE.

312. Different Varieties of Superstructure.—Bridges, as regards the design of the superstructure, may be thus classified:—

1. Girder bridges.
2. Arched bridges.
3. Suspension bridges.
4. Movable bridges.

Another class might be given which includes all bridges having two or more of the above designs in combination.

313. Cast-Iron Girder Bridges.—The oldest form of girder bridges, if we except those made of timber, were constructed of cast iron; this material is now rarely employed except in small spans.

There is very little variety of design in a cast-iron girder, it consisting merely of top and bottom flanges rectangular in section and joined together by a continuous web.

From experiments made by Hodgkinson, Fairbairn, and others on cast-iron girders supported at the ends and loaded, they found that in order that the top and bottom flanges be of equal strength their respective areas should be in the proportion of 1 to 6.

This proportion is correct as regards the resistance of the flanges against fracture. This principle, however, is scarcely the correct one to adopt in designing a girder; the proportions of the flanges ought to be fixed so that when the girder is gradually loaded their limits of elasticity be reached about the same time; and on this principle it will be found that the proportions between the sections of the top and bottom flanges should be about 1 to 3, and in practice this rule is pretty generally followed.

Cast-iron girders are suitable for road-bridges of small span, where they may be placed from 3 to 6 feet apart, brick arches being built in between them and resting on their bottom flanges (see fig. 229). In an arrangement of this kind when a heavy load, such as the wheel of a heavily laden waggon, rests on the top of the arch, an outward thrust is produced on the arch, which tends to push the adjoining girders apart from each other. This may be provided against by having a series of wrought-iron tie-bolts, placed from 5 to 10 feet apart, running across the bridge transversely, and attached to the web of each girder by nuts or cotters.

Perhaps the best method of producing this lateral stiffness is by means of a series of independent ties between each girder. Fig. 230 shows a skeleton plan of four girders, which explains what is meant. Instead of having three continuous tie-bolts passing through the webs of the four girders *a*, *b*, *c*, *c*₁, there are nine ties altogether—three of which brace *a* and *b* together, three brace *b* and *c*, and three brace *c* and *c*₁. In each of the girders

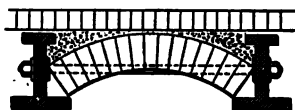

Fig. 229.

b and *c* there will be six holes, and in each of the outside girders *a* and *c*₁ three holes. A projecting boss is cast round each hole to compensate for the loss of metal. With the arrangement shown, each tie-bolt can be slackened or tightened by screwing the nuts at its extremities.

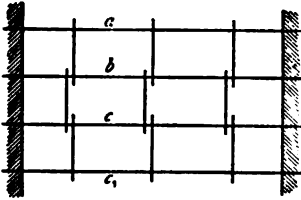

Fig. 230.

After the brick arches have been built, the haunches may be filled up with ballast, and then the roadway laid.

A floor formed of brick arches is necessarily very heavy, and instead of arches wrought-iron bent plates may be used, resting on the top flange when that member is straight. Flat cast-iron plates resting on either flange may also be employed.

314. **Wrought-Iron and Steel Girders for Bridges.**—Girders of wrought iron or steel are of great diversity of design, when used in bridges. Wrought-iron girders have been made for spans up to 500 feet. Theoretically, they may be made much longer, though they are not economical. Girders in steel, on account of the superior strength of this material, may be used for much larger spans than those of wrought iron, though up to the present few bridges of the ordinary girder type have been constructed of this material for large spans.

Large steel bridges of the cantilever type (see figs. 226 and 227), like the Forth Bridge, and similar structures, have been found very economical.

The proportion between the depth and length of bridge-girders varies considerably. Generally speaking it is from $\frac{1}{8}$ to $\frac{1}{15}$ for simple girders, and from $\frac{1}{15}$ to $\frac{1}{20}$ for continuous girders.

315. All girders consist of two main parts:—

1. The Flanges or Booms.

2. The Web.

The flanges may be constructed almost of an infinite variety of forms, the simplest consisting of a single T-bar or a pair of angle-bars, while the webs may be made either of a continuous plate or of a system of braces. The webs may also be either single or double, in which cases the girders are called single-webbed and box girders respectively.

Fig. 231 represents the cross-section of the most common kind

of girder. Each flange consists of one or more plates and a pair of angles, and the web consists of a single plate. All these parts are rivetted together somewhat after the manner shown; the pitch of the rivets longitudinally being about 4 inches. Usually the web is stiffened by vertical tee- or angle-bars placed in pairs one at each side of the web, and spaced longitudinally from about 3 to 6 feet apart.

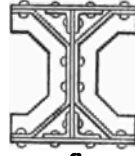

Fig. 231.

In applying the usual formula for calculating the flange-stress of such a girder loaded uniformly—*viz.*, $S = \frac{Wl}{8d}$ (see p. 159)—the depth of the girder as given by

d should, theoretically, represent the distance between the centres of gravity of the two flanges; but, as in this formula any aid given to the flanges by the web is not taken into account, it will be sufficiently accurate if d be taken to represent the total depth of the girder. In lattice-girders, however, d should be taken to represent the depth measuring from the backs of the top and bottom angles, which approximately correspond with the centres of gravity of the flanges.

316. Girders made of Different Materials in Combination.—Girders are sometimes made with a combination of wrought and cast iron. The members in compression, such as the top boom and the compression braces of the web, being made of cast iron, while the bottom boom and the tensile braces of the web are made of wrought iron. This construction is adopted with the object of taking advantage of the superior strength of cast iron to resist a direct compressive stress; but the combination, though good in theory, is not to be recommended in practice, partly on account of the difference in the moduli of elasticity of the two materials (see Art. 18).

There is a further objection to the employment of these two materials in large girders, owing to the production of secondary stresses caused by the unequal contraction or expansion of the two materials from change of temperature.

Another combination sometimes employed in plate web girders, is to have the flanges made of mild steel and the webs of wrought iron. The objections just referred to do not apply to this arrangement, and it has the advantage of being economical.

317. Plate Web Girders.—The plate forming the web of a girder may be in one or more lengths, the joints being vertical and covered at both sides with plates or tee-bars. The web need not be of the same thickness throughout in girders with distributed loads, it being thickest at the ends of the girder where

the shearing stresses are greatest, and diminishing by gradations towards the centre, where they are a minimum. The joints in the web should always be planed so as to make a good butt joint, and the strength of the cover-plates and the number of rivets forming the joint should be sufficient to withstand the stresses to which they may be exposed.

The minimum thickness of the web should not, as a rule, be less than $\frac{5}{16}$ inch, and, for important girders, not less than $\frac{3}{8}$ inch. If made thinner, and corrosion takes place, which it does rapidly in some situations, the margin of strength left is not great.

The web should be suitably stiffened at intervals, by bars of tee- or angle-section, either singly, or in conjunction with gusset plates. This prevents any buckling of the web, and also gives lateral rigidity to the girder.

318. **Stiffeners for Web.**—The tee- or angle-stiffeners for the web may be arranged in three different ways, as shown in figs. 231, 232, and 233. In fig. 232 the stiffeners are straight, flat packings being placed between them and the web. In fig. 233 the backs of the stiffeners go against the web, their ends being what is termed *joggled* over the main angles of the girder. This arrangement is neater than the former, and the packings are dispensed with. On the other hand, it is not quite so effective; besides, there is the cost of joggling the ends. This “joggling”

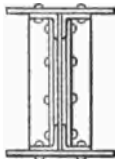

Fig. 232.

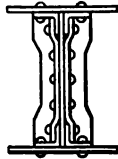

Fig. 233.

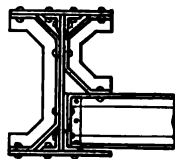

Fig. 234.

is most expeditiously done by heating the ends to a red heat, and placing the bar between a pair of suitable cast-iron blocks worked by hydraulic pressure.

Fig. 231 represents the third method, the stiffener being what is termed *cranked*, or splayed out over the main angles; this *cranking* is also done in the hydraulic press. For girders with broad flanges this is decidedly the best method, as the edges of the flange-plates are supported, and greater lateral stiffness is given to the girder.

In all these cases a gusset-plate may be rivetted to the projecting web of the angle- or tee-stiffener, and this plan should be adopted in large girders. All these stiffeners occur in pairs, one

at each side of the web; their distance apart longitudinally varies according to circumstances from about 3 to 8 feet. A pair of angle-stiffeners is usually placed at each end of the girder and also at the edges of the abutments.

Wherever a heavy fixed concentrated load rests on the girder, whether on the top or bottom flange, there should be a pair of stiffeners to distribute the load between the flanges. Such cases occur where the cross-girders of a bridge rest on the main girders, as is shown in fig. 234. A good arrangement in this case is to crank one of the stiffeners on the cross-girder—as shown—and to which it is secured by rivets. This forms a capital method of stiffening the main girders, and is equally applicable to those with lattice-webs.

319. Rolled Beams.—Rolled beams come under the head of single-web plate girders. They are made of wrought iron or mild steel in lengths up to 50 feet, and of depths from 3 to 24 inches, with a width of flange varying from $1\frac{1}{2}$ to 8 inches.

This form of girder is very suitable for the floors of warehouses and similar buildings. Their use in bridges is limited to the cross-girders and longitudinal bearers, except in bridges of small span, when they may be used for the main girders. Rolled beams can never be used economically for large spans, unless some method is adopted whereby they can be rolled with an increased area of flange and a diminished thickness of web towards the centre.

320. Box - Girders.—In girders with wide flanges, or those whose webs are exposed to great stresses, it is advisable to have two or even three webs to connect the flanges together. Such girders are called *double-webbed* or *treble-webbed*, or, more com-

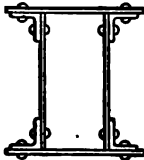

Fig. 235.

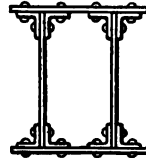

Fig. 236.

monly, box-girders. Figs. 235 and 236 represent some common sections of box-girders. That shown in fig. 236, which contains 8 rows of main angles, is a much stronger form than that shown in fig. 235, which only contains 4 rows; for, in addition to the increased strength of the flanges, the rivet connection between the webs and flanges is twice as strong in the former

case, where they are in double shear, than in the latter, where they are only in single shear.

There is no difficulty in putting the rivets in the girder shown in fig. 235, but in that in fig. 236 the space between the webs must be sufficiently great to allow a man or boy to get inside in order to hold the rivets in their place while the heads are being formed. Web-stiffeners are not so requisite in box-girders as in single-web girders, on account of their greater stiffness. When they are used they should be of the forms shown in figs. 232 or 233.

In large box-girders with plate-webs, one or more manholes should be provided, so that the interior can be scraped and painted periodically. In small box-girders, special precautions should be taken to prevent the formation of rust by well scraping the plates, and painting them with bituminous paint before rivetting them together. In order to provide against waste by oxidation, it is always advisable to make the plates thicker than that necessary by mere considerations of strength. The difficulty of cleaning and painting the interior of box-girders will always be an objection to them.

The practice formerly much used of making the top booms of large girders to consist of a series of cells or rectangular tubes, a notable example of which occurs in the Britannia Tubular Bridge, though correct in principle, is open to the objection just mentioned; and for this among other reasons this plan of construction has fallen into disfavour with modern engineers.

321. Lattice-Girders.—The booms of lattice-girders are of the same construction as those of plate-girders, the difference between the two classes being altogether in the construction of the web.

The web of a lattice-girder consists of a series of braces vertical and inclined at an angle, which connect the two flanges of the girder, and transmit the stresses from one to the other. Lattice, like plate-girders, may consist of a single or double web. They present a lighter and more pleasing appearance, and more readily adapt themselves to variety of design, and where the girders are large are much more economical than plate-girders. They also possess the advantage of not offering so great an obstruction to the wind. This is a very important consideration in bridges resting on high piers.

322. Platforms of Bridges.—The platform of a bridge consists of the cross-girders, longitudinal or rail bearers, road plates, wind-bracings, &c. Of late years, wrought-iron or steel trough flooring has come into use, and where this is employed, there is no necessity for cross-girders and longitudinal bearers.

DIFFERENT KINDS OF FLOORS FOR BRIDGES.

It is easier to form some idea of the weight of the flooring in railway bridges than in road bridges. Mr. Baker estimates the weight of the flooring and wind-bracing of a double line of railway bridge supported by two main girders as follows:—

TABLE XCVIII.

Span in Feet.	Dead Load per Foot Run of Platform.
10 to 100	14 cwts.
100 to 150	15 "
150 to 200	16 "
200 to 250	17 "
250 to 300	18 "

323. Method of attaching the Platform.—The platforms of bridges are usually connected to the top or bottom flanges of the main girders. Circumstances may sometimes make it advisable to connect them to the webs, but such cases are rare, and such a method is not to be recommended if it can be avoided.

The most economical arrangement for the platform occurs when there are several main girders to each span, and placed at short distances apart from each other. If the distance between their adjacent edges does not exceed 5 feet, and it be advisable to have an iron floor, a good plan is to have wrought-iron or steel buckled or curved plates resting on the top flanges, and rivetted thereto. With this arrangement, if the plates be properly butted together and covered with strips, they may, to a certain extent, be considered part of the top flanges of the main girders, thereby serving a double purpose.

324. Different kinds of Floors for Bridges.—The floor of a bridge may be made of wood, brickwork, iron, or steel. One of the most primitive methods consisted in laying timber planking or flag-stones on the tops of the girders. Another method consisted in building brick arches between the girders, the arches resting on the bottom flanges, as explained in Art. 313. Iron or steel plates, either straight, curved, buckled, or corrugated, resting on the flanges, have been used instead of brick arches in more recent times, and possess the manifest advantage of not adding so much dead weight to the structure.

The great majority of bridges consist of only two main girders for each span, and it becomes necessary to connect them together by a number of cross-girders, which may rest either on their top or bottom flanges; in the great majority of bridges on the bottom flanges.

When the distance apart of the main girders is not great, or when the loads coming on the bridge are small, the cross-girders may be made of cast iron, or, preferably, of wrought iron or steel rolled girders. In bridges liable to heavy loads, or when the distance between the main girders is considerable, the cross-girders should be wrought-iron or steel rivetted girders.

325. Distance apart of the Cross-Girders.—The distance apart of the cross-girders, neglecting exceptional cases, varies between 3 and 12 feet. When the distance does not exceed 5 feet the arrangement adapts itself for covering them with timber flooring or iron plates. When placed further than this it will be found necessary to introduce short girders between, running longitudinally and parallel to the main girders. These are termed *rail-bearers* or *road-bearers*, according as the structure is a *railway*- or *road*-bridge, and the flooring rests upon them.

In railway-bridges, or road-bridges liable to heavy concentrated rolling loads, it is not economical to have the cross-girders close together, as each will have to be made strong enough to carry a large proportion of the rolling load. In a railway-bridge, for example, they will have to be made as strong, or nearly so, when they are placed 3 feet apart as when they are placed 6 feet. In either case they must be made strong enough to support a pair of driving wheels of the engine, or in a double line of rails, two pairs of wheels.

Take the case of a bridge of 300 feet span carrying a double line of railway; the live load on such a bridge would be about 2 tons per lineal foot for both lines. If the cross-girders be placed 3 feet apart, the live load coming on each would be a great deal more than $3 \times 2 = 6$ tons. Each girder may have to support two pairs of driving wheels of the engines, which may amount to 24 or even 30 tons. If the cross-girders be placed 6 feet apart, the live load coming on each is practically the same as in the former case, and the weight of each girder will be very little more. From this it will be seen that the total weight of the cross-girders will not be much more than half when they are placed 6 feet apart than when they are placed 3 feet, so that the saving in the platform is apparent. It may be more economical still to place them 12 feet apart; in this case, of course, there will be the weight of the rail-bearers to take into consideration, but the extra weight of these will not be so great as the saving of weight in the cross-girders.

Generally speaking, it may be laid down as a rule that, when the cross-girders of a railway-bridge are spaced at intervals less than 6 feet, the live load on each will consist of the heaviest

load on one pair of wheels of the engine for a single line, and twice this for a double line of rails. When placed at intervals of over 6 feet, in addition to this load, there will be a proportion of the loads on the other wheels to be taken into account, and this proportion will increase with the distance apart of the cross-girders. For example, suppose the distance apart of the cross-girders to be 12 feet, and the engine to be supported on three pairs of wheels, the axles of which are 6 feet apart. If the weight on the leading wheels be 8 tons, that on the driving wheels 15 tons, and that on the trailing wheels 9 tons, the maximum rolling load on each girder will be $15 + \frac{1}{2} (8 + 9) = 23.5$ tons.

The economy of placing the cross-girders far apart only applies in a modified degree to road-bridges, as in such bridges the dead weight of the roadway is a considerable part of the total load.

The following Table* shows the relative economy of cross-girders placed 3 feet and 12 feet apart in railway bridges:—

TABLE XCIX.

	Span.	Total Load on Girders.	Net area of Bottom Flange.	Weight of Girders.	Weight per Foot Run of Bridge.
	Ft.	Tons.	Sq. Ina.	Lbs.	Lbs.
SINGLE LINE.					
Cross-girders, 3 feet apart, .	14	17.26	6.3	1,206	268.2
Cross-girders, 12 feet apart,	14	29.35	10.93	1,700	
Longitudinal rail-girders, .	12	19.54	10.8	1,518	
DOUBLE LINE.					
Cross-girders, 3 feet apart, .	25.5	35.00	11.4	3,654	1,218
Cross-girders, 12 feet apart,	25.5	58.64	19.2	4,704	645
Longitudinal rail-girders, .	12	38.64	21.6	3,026	

326. Intermediate Bearers.—The longitudinal rail-bearers or *stringers*, as they are sometimes called, are small girders which run in a direction parallel to the main girders of the bridge. They either rest on the cross-girders, to which they are attached,

* *Trans. Inst. of C.E., Ireland*, vol. viii., 1866.

or fit in between them. In the latter case their tops are usually made flush with the tops of the cross-girders. In road-bridges the distance apart of the bearers depends on the kind of floor used. When the latter consists of flat, curved, or buckled plates, the distance will vary between 3 and 5 feet. In railway bridges the bearers are placed underneath the rails, and are 5 feet apart. In this case the greatest load to which they are liable is the weight of the driving wheel of the engine resting on the centre. This may amount to as much as 8 tons. When they rest on the cross-girders they may be made continuous and, therefore, much lighter, especially in road-bridges.

327. Roadway-Timber Flooring.—Timber flooring without any ballast is often used for foot-bridges and sometimes for private road-bridges. The usual thickness of planking employed varies from $2\frac{1}{2}$ to 4 inches, and the supports on which it rests should be placed at distances varying from 3 to 6 feet apart.

In foot-bridges where the main girders are not more than 4 feet 6 inches centres, the planking may be laid transversely with the length of the bridge, the ends resting on the bottom flanges of the girders and bolted thereto.

A better plan, however, and one that is applicable no matter what distance apart the main girders may be, is to lay the planking longitudinally with the bridge and allow it to rest on cross-bearers, or cross-girders, which are attached to the bottom flanges of the main girders. These cross-bearers in foot-bridges up to 8 feet wide may consist of suitable wrought-iron or steel T-bars suspended by bolts or rivets to the main girders, and placed not further apart than 6 feet. Holes are punched at intervals along the backs of the bearers for the purpose of bolting the planking. With this arrangement each plank may extend over three or four bays, and this continuity adds materially to the strength of the floor. When the main girders are further apart than 8 feet, rolled beams or rivetted girders should be used for cross-girders. A good method of giving lateral stiffness to the main girders arranged on this plan is to prolong every third or fourth cross-bearer beyond the sides of the main girders and to introduce a raking strut, which may be of angle- or tee-section, this strut being rivetted both to the girder and the cross-bearer.

Timber flooring should not be relied upon to resist the horizontal lateral stresses on the bridge produced by wind-pressure. To provide for this, bars of wrought iron arranged diagonally should be bolted or rivetted to the main girders and cross-bearers and continued the whole length of the platform.

Timber flooring may be used for railway bridges when it is desirable to keep the first cost as low as possible, though it cannot be recommended for first-class structures. The sketch shown in fig. 237 represents a common arrangement. The cross-girders should be placed about 4 feet apart, and upon these are laid longitudinal timber sleepers about 12 inches by 6 inches, to which they are attached by angle plates and bolts. Between the sleepers, and at either side, longitudinal planks from 3 to 4 inches in thickness are laid, and bolted to the cross-girders. It is customary to place a layer of ballast, preferably of ashes, on account of its lightness, to a depth of about 3 inches over the whole surface of the platform, so as to prevent the timber being ignited by sparks from the engine. In this case the planks should be close-jointed to prevent the ballast falling through. When there is no ballast there is no necessity for this, and it is advisable to lay the planks with spaces between them of from $\frac{1}{4}$ to $\frac{1}{2}$ inch, so that water may the more easily escape.



Fig. 237.

328. Iron Flooring.—The floor of a bridge when made of iron or steel may be constructed in the following ways :—

1. Cast-iron plates.
2. Wrought-iron or steel plates, flat or curved.
3. Buckled plates.
4. Corrugated flooring.

Cast-Iron Flooring Plates.—When the floors of road-bridges are made of cast-iron plates, they may be bolted to the top flanges of the cross-girders or longitudinal bearers. They are usually made square, about 3 or 4 feet on the side, and have stiffening ribs cast diagonally on the upper surface, and vertical flanges at the sides for bolting to each other. The thickness depends upon their size and the loads coming on them, and usually varies between $\frac{3}{8}$ and 1 inch. After being laid, they are levelled up with concrete to the tops of the ribs, which are from 3 to 4 inches deep. On the concrete is laid the road metalling.

Wrought-Iron and Steel Flooring Plates.—Wrought-iron and steel road-plates may be either flat or curved. They are rectangular in form, usually from 3 to 5 feet on the side, and from $\frac{3}{8}$ inch to $\frac{1}{2}$ inch in thickness. They may be rivetted to the flanges of the main girders, cross-girders, or longitudinal bearers, as the case may be. They are much stronger in the curved form,

and in such case their haunches are levelled up to the crown with concrete, on which the road metalling is laid. The plates may be bent cold by pressing them through rolls to give them the requisite curvature, and then flanged at the edges.

This flanging may be done cold in a press, care being taken that the line of curvature of the plate is in the direction of the fibre of the iron; if not, the plate is liable to be cracked in the process of flanging.

The rise of the crown for plates 4 feet span usually varies between $1\frac{1}{2}$ and 4 inches; the greater the curvature the stiffer the plate. When the plates are laid on girders or bearers, the latter ought to be tied or braced together to prevent them spreading laterally under a passing load.

For good work the edges of the road-plates should be planed, so that they may butt evenly together; the joint between two plates may be covered with a single flat strip or tee-bar placed on the top side and rivetted thereto. This is sufficient for curved plates. For flat plates a double flat strip or one strip and one tee-bar are often used, one being placed above and the other underneath the plates, the whole being rivetted together.

329. Strength of Wrought-Iron Flat Road-Plates.—With a flat plate supported on two parallel edges, but not fastened thereto, the bending moment exerted by a load placed on it is the same as that produced on a beam of the same span similarly loaded. When the plate is rivetted along its four edges to the bearings the bending moment is much less; but it is not easy to determine theoretically. Prof. Rankine* gives the following rules for determining this bending moment, which must only be considered as approximately correct:—

“ Let W denote the total load.

l , the length of the plate, between the supports of its ends.

b , its breadth, between the supports of its side edges.

M , the greatest bending moment.

Case I.—Square plate, load uniformly distributed—

$$M = \frac{W b}{16} \quad \dots \quad (1).$$

Case II.—Square plate, load collected in the centre—

$$M = \frac{3 W b}{16} \quad \dots \quad (2).$$

* Rankine's *Civil Eng.*, p. 544.

Case III.—Oblong plate, load uniformly distributed—

$$M = \frac{W l^4 b}{8 (l^4 + b^4)} \quad . \quad . \quad . \quad (3).$$

Case IV.—Oblong plate, load collected in the centre; l less than $1.19 b$ —

$$M = \frac{3 W l^4 b}{8 (l^4 + b^4)} \quad . \quad . \quad . \quad (4).$$

Case V.—Oblong plate, load collected in the centre; l equal to or greater than $1.19 b$ —

$$M = \frac{W b}{4} \quad . \quad . \quad . \quad (5),$$

being the same as for a plate supported at the *side edges only*.

Case VI.—Circular plate, of the diameter b , supported all round the edge, load uniformly distributed—

$$M = \frac{W b}{6 \pi} = .053 W b \quad . \quad . \quad (6).$$

Case VII.—Circular plate, load collected in the centre—

$$M = \frac{W b}{2 \pi} = .159 W b \quad . \quad . \quad (7)."$$

Curved plates rivetted at their edges resemble arches in the direction of the curvature; in the other direction they resemble flat plates.

It is always advisable to have a large margin of strength in wrought-iron or steel flooring plates, as in time they suffer considerable deterioration through rusting.

330. Buckled Plates.—Buckled plates are the invention of Mr. Mallet; they are dish-shaped in form, and have a flat rim round the four edges; they may be square or oblong. They are formed from ordinary flat plates by blocking them, when hot, between a pair of suitable dies. They form a very strong and at the same time light roadway. They usually vary between $\frac{3}{16}$ and $\frac{1}{2}$ inch in thickness, though in special cases they are made thicker. Like ordinary flat or curved road-plates, they are rivetted to the girders or bearers of the bridge, but unlike ordinary bent plates they do not exert any, or very little, outward thrust when loaded, so that it will not be necessary to tie the bearing girders together. The joint where two plates butt together should be covered with a tee-bar; this strengthens the plates at their weakest part.

TABLE C.

No.	Thickness of Plate.	Weight per Square Yard of Buckled Plate, excluding the Angle Iron at the Cross Joints.	Weight of an Equal Surface (Square Yard) of Straightened Plate of Corresponding Thickness.	Safe Passive Load, Uniformly Diffused per Square Yard for $\frac{3}{8}$ Foot Square Buckled Plates.	Safe Impulsive Load, Uniformly Diffused per Square Yard for $\frac{3}{8}$ Foot Square Buckled Plates.	Cost per Superficial Yard of Buckled Plate at £13 per Ton.	Nearest Number of Square Yards in 1 Ton of Buckled Plates.
	B. W. G. Inch.	Lbs.	Lbs.	Tons.	Tons.	s. d.	Square Yards.
1	No. 18 = 0.48	17.3	20.7	0.27	0.20	2 2	129
2	No. 16 = 0.66	23.6	28.3	0.43	0.32	2 10	95
3	No. 12 = 1.07	38.7	46.4	0.64	0.48	4 7	57
4	$\frac{1}{2}$	45.0	54.0	1.0	0.75	5 3	49
5	$\frac{5}{16}$	67.5	81.0	2.5	1.7	7 11	33
6	$\frac{1}{4}$	90.0	108.0	4.5	3.0	10 6	24
7	$\frac{5}{16}$	112.5	135.0	6.2	4.7	13 2	20
8	$\frac{3}{8}$	135.0	162.0	9.0	6.8	15 8	16

NOTE.—The safe loads in columns 5 and 6 may be taken at double for buckled plates of puddled steel.

Nos. 1, 2, and 3.—Applicable to roofing, iron house building, and fireproofing, flooring, &c.

Nos. 4 and 5.—For the lighter class of bridge and other floors.

Nos. 6 and 7.—For the heavier floors of railway and other bridges, and viaducts—No. 6 is that adopted for the new bridge at Westminster, London; No. 7 for bridges in India.

No. 8.—Has not hitherto been found necessary in any structures, however heavy.

331. Strength of Buckled Plates.—A buckled plate rivetted down to its bearings all round the edges is twice as strong as the same plate merely resting on its supports. The strength of a square buckled plate varies directly as its thickness and inversely as its bearing. From experiments made, it was found that a buckled plate 3 feet square, made of ordinary Staffordshire iron $\frac{1}{4}$ inch thick, and with a rise at the crown of $1\frac{1}{4}$ inches, and a fillet of 2 inches wide all round, required 9 tons spread over half the area of the crown to cripple it down when it merely rested on its edges. When it was rivetted down it required a weight of 18 tons to cripple it. A similar plate of puddled steel bore 35 tons under similar conditions, but the quality of this steel must have been better than that ordinarily used for bridge-work.

Table C.* gives some useful information about buckled plates.

332. Patent Troughs and Corrugated Flooring.—The introduction of trough flooring, both for bridges and warehouses, is of comparatively recent origin. Two features of merit possessed by this system are—(1) It produces an even distribution of the load on the main girders instead of a series of concentrated loads at the points of application of the cross-girders; (2) It dispenses with the necessity of cross-girders and bearers, and its small depth gives increased head-room, which, in many cases, is an important consideration. Many systems of trough flooring have been patented within the last few years, the best known of which are—

Lindsay's Patent Troughs,
Westwood & Baillie's Corrugated Flooring,
Hobson's Patent Flooring.

Besides these, other forms, which are not patented, are used a great deal.

333. Lindsay's Patent Troughs.—Fig. 238 represents a cross-section of one of Lindsay's troughs; these are made of mild steel capable of sustaining an ultimate tensile stress of not less than 30 tons per square inch, with an elongation of 20 per cent. The main advantage of flooring of this kind is, that no cross-girders or bearers of any kind are required. The troughing rests on, and is rivetted to the top or bottom flanges of the main girder, or to an angle-iron rivetted to the web. The

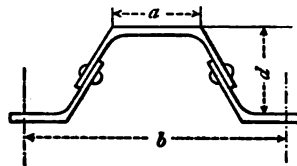

Fig. 238.

* *Theory of Strains*, by B. B. Stoney.

following advantages are claimed by this system in a circular issued by the patentees:—

“The improvements consist in utilising rolled sections of splayed channel steel so that the top table shall be thicker than the sides, in order to approach the theory of the girder principle as much as possible, by which means the metal is taken away from the web and added to the flanges, thereby increasing the sectional strength of the trough, and producing a greater moment of resistance over a floor which is composed of an uniform thickness of plate, without increasing the weight of steel to the square foot of area to be covered.

“The cost of manufacture is reduced to a minimum by rivetting the trade rolled-sections together with a single row of rivets, at such a point in the section where the strain is almost neutral.

“The strength of the decking, when rivetted together, is considerable. Each trough may be treated as a girder, but then each girder is connected to its fellow; thus, when the weight is applied, say on one trough, it cannot deflect without dragging on the adjoining troughs for some distance from the point of weight. All the sections from O to D have been carefully designed and investigated.”

The student will not have much difficulty in determining the strengths of the different sections of this flooring. Take the case of section D for example; here the effective flange area, which includes part of the web, is 9.36 square inches; the effective depth is 10 inches; and, taking the working stress on the steel as 7 tons per square inch, we get the safe working moment of resistance = $7 \times 9.36 \times 10 = 655.2$ inch-tons.

The moments of resistance of the other sections may be found in the same way, and are given in conjunction with the sections in the table. By equating these expressions to the bending moments, the safe working loads that the different sections of troughing will carry may be found for different spans.

Take the case of a single line of railway; the span of the trough for this will be about 16 feet. If the distance apart of each pair of wheels of a locomotive be 6 feet 6 inches, then for a

trough of the maximum section C, there will be $\frac{78}{20} = 3.9$ troughs

to support the load on a pair of wheels. This section, as will be seen by referring to the table, has a safe moment of resistance of 203.6 inch-tons; hence, $203.6 \times 3.90 = 794.07$ inch-tons, which represents the safe moment of resistance of the troughing which supports a pair of wheels.

If W = weight on each wheel, then (see fig. 239) $66 W = 794.07$

= bending moment on the flooring which supports a pair of wheels; the span being 16 feet.

TABLE CI.—LINDSAY'S STEEL TROUGHS.

SECTION.	Width of flange (c).	Width of trough (b).	Depth of trough (a).	Thickness of flange.	Thickness of web.	Size of rivets.	Net weight per square foot.	Resistance of section in inch-tons.
	In.	In.	In.	In.	In.	In.	Lbs.	
O. Maximum,	4.0	12.0	4.0	$\frac{1}{8}$	$\frac{1}{8}$	$\frac{3}{8}$	15.5	43.80
O. Minimum,	4.0	12.0	4.0	$\frac{1}{4}$	$\frac{1}{8}$	$\frac{3}{8}$	13.0	37.30
A. Maximum,	4.5	14.0	5.0	$\frac{3}{8}$	$\frac{1}{8}$	$\frac{1}{2}$	19.16	65.22
A. Minimum,	4.5	14.0	5.0	$\frac{1}{4}$	$\frac{1}{8}$	$\frac{1}{2}$	16.0	53.42
B. Maximum,	5.0	16.0	6.0	$\frac{1}{2}$	$\frac{1}{4}$	$\frac{1}{2}$	25.05	113.34
B. Minimum,	5.0	16.0	6.0	$\frac{3}{8}$	$\frac{1}{4}$	$\frac{1}{2}$	21.60	100.35
C. Maximum,	6.0	20.0	7.0	$\frac{5}{8}$	$\frac{1}{4}$	$\frac{5}{8}$	27.10	203.61
C. Minimum,	6.0	20.0	7.0	$\frac{1}{8}$	$\frac{1}{4}$	$\frac{5}{8}$	22.40	156.94
D. Maximum,	9.0	32.0	12.0	$\frac{3}{4}$	$\frac{3}{8}$	$\frac{3}{4}$	34.83	655.20
D. Minimum,	9.0	32.0	12.0	$\frac{1}{2}$	$\frac{1}{8}$	$\frac{3}{8}$	25.82	501.13

From this equation we get $W = 12$ tons, the weight on each wheel. The weight on each driving wheel of a locomotive does not, as a rule, exceed 7.5 or 8 tons, and if the proportionate dead weight of the flooring be taken at 2 tons, there will be a total weight of 9 tons at each point, from which it will be seen that the section gives a considerable margin of strength.

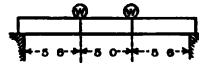

Fig. 239.

When the main girders are from 14 to 15 feet apart, the B maximum section is sufficiently strong for the above loads. If, as before, 6 feet 6 inches be taken for the wheel base, we get $\frac{78}{16} = 4.875$ troughs, the safe moment of resistance of which = $113.34 \times 4.875 = 552.53$ inch-tons. Supposing the main girders to be 14 feet apart, there is a leverage of 54 inches between the

load and the bearing; hence the safe load on each wheel = $\frac{552.53}{54} = 10.23$ tons, an excess over what is required, viz., 9.5 tons.

It will be noticed in the above calculations, that it is assumed that not only the particular trough immediately underneath the load, but also those contiguous to it, do their full share of work in assisting to support the load, that in effect each trough is strained to the same extent. This in theory, perhaps, may be correct, but whether it is so actually is doubtful; it is more likely that the trough immediately underneath the load is exposed to greater stresses than those near it, but as to how much the stresses differ, can only be determined by actual experiment. It will be well, therefore, to allow a somewhat greater margin of safety than that above indicated, more especially as the working stress of 7 tons is rather high. When the floor of a bridge is uniformly loaded, this unequal straining does not occur.

Distributed Load—

Let l = span in inches.

R = resistance of section of one trough.

W = distributed load on each trough, in tons.

$$\text{Then } W = \frac{8R}{l}.$$

For example, find the safe distributed load which the maximum section B will sustain for a span of 15 feet.

$$R = 113.34, \quad l = 180 \text{ inches.}$$

$$W = \frac{8 \times 113.34}{180} = 5.04 \text{ tons.}$$

A floor made of this section of troughing, with a span of 15 feet, will carry with safety $\frac{5.04 \times 2240}{1.33 \times 15} = 564.5$ lbs. per square foot of surface.

The section D maximum has been designed by the patentees to carry with safety a double line of railway between two main girders. Its weight per square foot of area covered is 34.83 lbs., and its safe sectional resistance 655.2 inch-tons.

The weight coming on a pair of wheels of the locomotive may be taken to be spread over $2\frac{1}{2}$ troughs, whose moment of resistance = $655.2 \times 2.5 = 1638$ inch-tons.

By referring to fig. 239, it will be seen that the centre of

gravity of each pair of driving wheels from the adjacent girder is 7 feet 6 inches. If two engines, one on each line, rest on the bridge side by side, and if W = load on each pair of wheels, then

$$W = \frac{1638}{90} = 18.2 \text{ tons, which is equivalent to about 9 tons on}$$

each wheel; this, of course, must include the proportionate dead weight of the floor as well.

Messrs. Lindsay & Co. recommend this section for road bridges of 30 and 35 feet span without the use of main girders, the troughing resting on each abutment, but a light parapet of corrugated or plate iron will be required.

CHAPTER XXVI.

BRIDGES—*continued.*

SUSPENSION BRIDGES.

334. Definition.—*A suspension bridge is one in which the platform is suspended from chains, which pass over towers erected on the piers and abutments, and the ends of which are anchored to the ground.*

When a flexible chain of uniform weight per unit of length is suspended at both ends, and allowed to hang freely, it assumes a curve which is known as the *catenary*. In uniformly loaded suspension bridges, the load is uniformly distributed with reference to a horizontal line, and the curve which a chain thus loaded assumes is a *parabola*.

In the simplest form of suspension bridge, the platform is hung from the chain by a series of vertical rods placed at equal distances from each other. The load may then be treated as hanging directly from each point in the chain where the suspending rods are attached. If the loads be all equal to each other, the form the chain will assume will be, as already stated, a parabolic curve. If the loads be different the chain will assume an irregular curve, the form of which may be easily found by the following graphical method:—

Take the vertical line AH (fig. 240), drawn to scale, to represent the total load suspended from the chain shown in fig. 241.

Set off A B, B C, C D, - - G H, to represent the loads suspended from each point of the chain in succession, reckoning from left to right. Let A O₁, H O₁ represent the vertical components of the loads coming on the points of suspension *a* and *b*, which can be readily found by the principle of moments. Draw the horizontal line O₁ O to represent the horizontal component of the tension which it is desired to place on the chain; this line will represent the actual tension on that point of the chain, the tangent to which is horizontal.

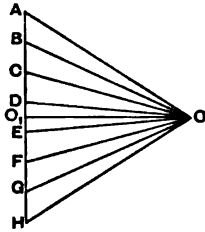

Fig. 240.

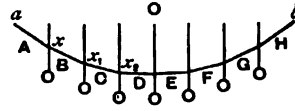

Fig. 241.

By joining O A, O B, O C, - - O H, these lines will represent, both in direction and magnitude, the tensile forces acting on each portion of the chain taken in succession. In fig. 241, *a* and *b* are the points from which the chain is suspended, the vertical lines in the figure representing the positions of the loads. Draw *a x* parallel to O A, *x x₁* parallel to O B, and so on. The curve so formed will represent the form the chain will assume under the conditions above specified.

If, instead of assuming a certain horizontal tension on the chain and then finding from this the form it assumes, we have given the maximum dip or versine, then the horizontal component of the tension may be found. For if *w₁*, *w₂*, *w₃*, - - represent the vertical loads at the various points distant, *x₁*, *x₂*, *x₃*, &c., from one of the points of suspension; then, approximately,

$$S_H = \frac{\sum w x}{d} \dots \dots \dots (1).$$

Where *S_H* = horizontal component of the tension at any point,
d = versine of the chain.

If the *form* assumed by a chain be given, and it be required to determine the loads acting at the different points which will

produce this *form*, the problem will be the converse of that already given, and may be solved thus—

From the point O, fig. 240, draw a series of lines parallel to the different segments of the chain and meeting a vertical line A H, taken at any convenient distance from O, at the points A, B, C, - - - H. The vertical loads required to keep a chain of such a form in equilibrium will be proportional to the lines A B, B C, C D, - - - G H.

When a uniform load is distributed along the roadway of a bridge, the main chains will form a parabolic curve. When a moving load passes over the bridge the curve which the chains assume changes with each position of the load, if the bridge be not stiffened.

In fig. 242, if half the span *ac* be supposed to be covered with a uniform load, while the other half has no load whatever, the curve of equilibrium for the left half, *adc*, would be a parabola, and that for the right half a straight line *cb*, and the chain theoretically would assume the form *adc b*.

It is unnecessary to say that in practice chains never assume the form of straight lines, and in the case under consideration the actual curve of the chain would be very different to that mentioned on account of the dead weight of the bridge and the stiffness produced by the bracing.



Fig. 242.



Fig. 243.

335. Chain Uniformly Loaded.—The chain *a O b* (fig. 243), suspended at the points *a* and *b*, is supposed to be uniformly loaded.

Let l = span,
 b = versine or depth,
 w = uniform load per unit of span.

Let S_o = stress at O, the apex of the parabola.

S_x = stress at a point A, whose horizontal distance from O is x .

θ = angle which the tangent at A makes with the horizontal;

$$\text{then } S_o = \frac{wl^2}{8d} \quad \cdot \quad \cdot \quad \cdot \quad (2).$$

AC is the tangent at A, meeting the tangent at O at the point C. BC is the horizontal component of the tension at A, and remains unaltered for all points on the curve, being $= \frac{wl^2}{8d}$.

AB is the vertical component of the tension at A; this is equal to the sum of the loads between A and O; or the vertical component of stress at A

$$= AB = wx \quad \dots \quad (3).$$

The direct tension at A = AC, or

$$S_x = AC = BC \sec \theta = S_0 \sec \theta \quad \dots \quad (4).$$

$$\text{Also } AC = \sqrt{(BC)^2 + (AB)^2}.$$

Substituting, we get—

$$S_x = \sqrt{\left(\frac{wl^2}{8d}\right)^2 + (wx)^2} \quad \dots \quad (5).$$

336. Method of Attaching the Main Chains to the Piers.—

Fig. 244 represents a suspension bridge of one span. *acb* is called the main or central chain, *ad* and *bc* are the side or counter chains, *aA* and *bB* are the towers or piers. The chain passes over the piers, and is anchored to the ground at *d* and *e*.

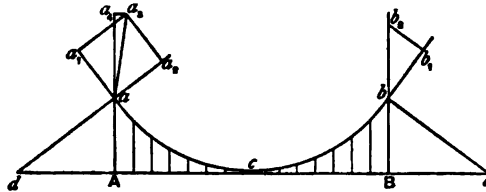

Fig. 244.

There are two methods by which the chains may be carried over the towers :—

(1) The main and counter chains may be in one *continuous length*, and pass over pulleys fixed to the tops of the piers.

(2) The main and counter chains may be independent chains, the ends of each being *fastened* to the top of the tower.

The stresses on the counter chains and the pressures on the piers are different according to which of these arrangements is adopted.

First Case.—When the chain passes over pulleys fixed on the

Produce the tangent at b to b_1 (fig. 244), making $b b_1 =$ stress on the main chain at b . Through b_1 draw $b_1 b_2$ parallel to $b e$, meeting the vertical through b at the point b_2 ; then

$b_1 b_2 =$ tension on the counter chain,
 $b b_2 =$ pressure on the pier.

Let $S_0 =$ horizontal component of tension on each chain,
 $S_1 =$ actual tension on centre chain at b ,
 $S_2 =$ " " counter chain "
 $i =$ angle of inclination of centre chain at b ,
 $i_1 =$ " " counter chain "

$$S_1 = S_0 \sec i. \quad . \quad . \quad . \quad (7).$$

$$S_2 = S_0 \sec i_1. \quad . \quad . \quad . \quad (8).$$

$$R = S_1 \sin i + S_2 \sin i_1 = S_0 (\tan i + \tan i_1),$$

where $R =$ vertical pressure on the pier.

337 Stresses on Suspending Rods.—If there be n equal spaces made by the suspending rods, then

$$\text{Tension on each rod} = \frac{w l}{2(n-1)}. \quad . \quad . \quad (9).$$

where $w =$ distributed load per unit of length,
 $l =$ span.

338. Suspension Bridge with Sloping Rods, Dredge's System.—Fig. 245 represents a suspension bridge, the platform of which is hung from the main chains by means of *parallel sloping rods*

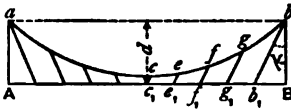

Fig. 245.

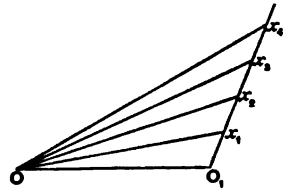

Fig. 246.

making an angle, γ , with the vertical. The curve formed by the chain in the case of uniform loading, consists of two parabolas with a common vertex, c , which have their axes parallel to the respective systems of suspending rods.

The principal difference between bridges of this class and

those with vertical suspension rods, is that with the latter the platform is not exposed to any longitudinal stresses arising from the vertical load, while with inclined suspension rods a series of longitudinal stresses are developed, which vary in intensity in different parts of the platform.

Let a = length of each bay of platform,

w = load per unit of length ;

Then wa = weight suspended from the end of each rod.

Tensile stress on each rod is

$$t = wa \sec \gamma. \quad (10).$$

Horizontal component of stress on each rod is

$$t \sin \gamma = wa \tan \gamma. \quad (11).$$

This will represent the increment of stress developed in the horizontal member at its junction with each suspending rod.

Tension on chain at c is

$$T = \frac{wl^2}{8d} - t \sin \gamma. \quad (12).$$

Tension at any other point is

$$T_1 = wx \operatorname{cosec} \theta. \quad (13).$$

x being the distance from the mid-span to the bottom of the sloping rod at the top of which T_1 is taken ; and θ the angle which the tangent, to the chain at the particular point makes with the horizontal.

Graphic Solution.—The tensions at the different parts of the chain can be most readily obtained by the graphic method.

Let the horizontal line OO_1 , fig. 246, be drawn to represent the stress at c . Through O_1 draw a line parallel to the suspending rods, and on it set off the distances O_1x_1, x_1x_2, x_2x_3 , &c., to represent the stresses on the rods ee_1, ff_1, gg_1 , &c., respectively. Join Ox_1, Ox_2, Ox_3 , &c. These lines will represent the stresses on the chain at the points e, f, g , &c.

339. Stresses on the Horizontal Member.—The stresses on the horizontal member or platform may be either compressive or tensile, according to the manner in which it is fixed. If the platform be fixed to the piers at A and B, the stresses will be compressive throughout, being a minimum at the centre and a maximum at the ends next the piers. If the horizontal member be free to move at the ends next the piers, it will be exposed to

tensile stresses throughout, they being a maximum at the centre and a minimum next the piers.

In the former case

$$S_{com} = + t \sin \gamma (14),$$

$$S_{end} = + n t \sin \gamma (15),$$

n being the number of suspension rods between the centre and the end.

In the latter case

$$S_{com} = - n t \sin \gamma (16),$$

$$S_{end} = - t \sin \gamma (17).$$

Graphic Solution.—The stresses on the members of a suspension bridge of this form may be readily determined by the aid of a stress diagram. Fig. 247 represents a suspension bridge in which the bottom horizontal member is not attached to the piers, and consequently is in tension. Draw the vertical line $Y X$, fig. 248, to represent the total weight suspended from one chain, or one-half

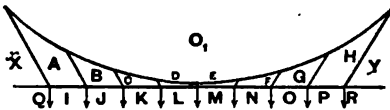

Fig. 247.

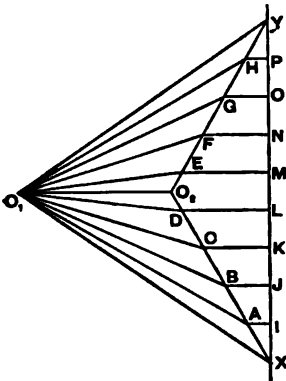

Fig. 248.

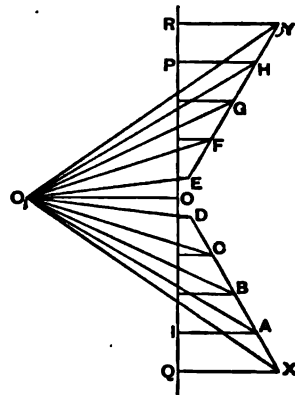

Fig. 249.

the total weight on the bridge. Set off $Y P, P O, O N, \&c.,$ to represent the weights resting at the ends of the suspension rods,

proceeding from right to left. Draw $Y E$ and $X D$ parallel to the suspending rods at the right- and left-hand portion of the bridge. Draw the horizontal lines $P H$, $O G$, $N F$, &c., meeting these lines at H , G , F , &c. These horizontal lines will represent the tensile stresses on the different bays of the horizontal member. The lines $Y H$, $H G$, &c., and $X A$, $A B$, &c., will represent the stresses on the inclined suspension rods.

If the horizontal tension at the centre of the chain be known, draw the horizontal line $O_2 O_1$ to represent it, join $O_1 Y$, $O_1 H$, $O_1 G$, &c.; these lines will be parallel to the different links of the chain, and will represent the stresses on them. If the horizontal tension at the centre of the chain be not known, draw $Y O_1$, $X O_1$ parallel to the end links, and, as before, the lines radiating from O_1 will represent the stresses on the different links, the line $O_1 O_2$ representing the horizontal component of these tensions.

If the horizontal member be attached to the piers so as to be in compression, the stress diagram will be that shown in fig. 249.

340. Practical Details of Suspension Bridges.—Main Chains.—The chains of suspension bridges are usually made of links of wrought iron or steel, or they may be made of wrought-iron or steel wire cables. When made of links, the latter are usually flat, with eyes formed at the ends, and are connected together by means of pins passing through the eyes. The best proportion to give to the eyes and pins is a very important question, and has been fully discussed in Chapter XXI. The strength of the chain may be varied at the different parts of its length so as to be in proportion to the stresses coming on it, by altering the number or the section of the links, or both. There must be at least two chains or cables to each bridge, one to support each side of the roadway. Large bridges may have more. In the Menai suspension bridge there are sixteen chains in four sets of four.

Professor Rankine * gives the following formulæ to show how both the absolute and comparative weights of chains of uniform section and strength may be determined, and these are sufficiently correct for practical purposes:—

“Let x be the half-span of the chain; y its depression, both in feet; the ordinary proportions of x to y range from $4\frac{1}{2} : 1$ to $7\frac{1}{2} : 1$.

Let O be the weight of a chain of the length x , and of a cross-section sufficient to bear safely the greatest working horizontal tension H .

* *Civil Engineering*, p. 573.

C' , the weight of a *half-span* of the chain of *uniform section*.

C'' , the weight of a *half-span* of the chain of *uniform strength*; then—

$$C' = C \cdot \left(1 + \frac{8}{3} \frac{y^2}{x^2}\right) \text{ nearly} \quad . \quad . \quad (18).$$

$$C'' = C \cdot \left(1 + \frac{4}{3} \frac{y^2}{x^2}\right) \quad . \quad . \quad (19).$$

The error of the first formula is in excess, and does not exceed 1-3000th part in any case of common occurrence in practice.

The value of C , in the above formula, may be taken as follows:—

For wire cables of the best kind—

$$C = \frac{Hx}{4500}; \quad . \quad . \quad . \quad (20).$$

For cable-iron links—

$$C = \frac{Hx}{3000}; \quad . \quad . \quad . \quad (21).$$

it being understood that the last formula gives the *net* weight only; in other words, the weight exclusive of the additional material in the eyes and pins by which the links are connected together.

About *one-eighth* may be added to the *net* weight of the chains for eyes and fastenings."

When each cable is composed of two sets of chains, one over the other in the same vertical plane, the suspension rods should be arranged in such a manner that each chain receives half the weight. This may be arranged in a variety of ways. By one method the suspension-rods may be attached to each chain alternately; a better plan, however, is to attach each rod to both chains.

The suspension-rods should be designed so that they may be lengthened or shortened in order that the requisite camber may be given to the roadway. This may easily be done by means of a screw and nut on the bottom ends, or the rods may be made in two lengths and connected together by a coupling with a right- and left-hand screw. The ends of the suspension rods may be attached to the cross-girders of the bridge; the distance apart of these latter vary according to circumstances, and usually range between 5 and 10 feet.

When the cables are made of iron or steel wire ropes they are of the *same section throughout their length*, and must be strong enough to resist the maximum stress coming on them, which is at the piers; there is, consequently, a waste of material in cables of this description.

The iron wire used in the Niagara and Cincinnati suspension bridges had a strength of $44\frac{1}{2}$ tons per square inch. Good steel wire has a strength of from 50 to 60 tons per square inch.

Three or four thousand wires may be used in one cable, and it is important that it be so made that the stress on each wire be practically the same. It is not necessary, in order to insure this, that the wires should be parallel. From experiments made it appears that cables spun with machines which lay the wire helically, but does not twist them, is as strong as those made of straight wires. The interstices between the wires should be filled with a bituminous compound.

341. Advantages of Suspension Bridges.—Suspension bridges have many advantages and many drawbacks. The principal advantage, when the nature of the ground is favourable, is their cheapness.

The late Prof. Jenkin remarks* :—“A man might cross a chasm of 100 feet hanging to a steel wire 0·21 inch in diameter, dipping 10 feet; the weight of the wire would be 12·75 lbs. A wrought-iron beam of rectangular section, three times as deep as it is broad, would have to be about 27 inches deep and 9 inches broad to carry him *and its own weight*. It would weigh 87,500 lbs. . . . The enormous difference would not exist if the beam and wire had only to carry the man, although, even then, there would be a great difference in favour of the wire; the main difference arises from the fact that the bridge has to carry *its own weight*. The chief merit of the suspension bridge does not, therefore, come into play until the weight of the rope or beam is considerable when compared with the platform or rolling load; for although the chain will, for any given load, be lighter than the beam, the saving in this respect will, for small spans, be more than compensated by the expense of the anchorages. In large spans the advantage of the suspension bridge is so great that we find bridges on this principle of 800 or 900 feet span constructed at much less cost per foot run than girder-bridges of half the span.”

342. Disadvantages of Suspension Bridges.—There are many disadvantages attending these bridges, the principal being want of rigidity, both in a vertical and a lateral direction. This want

* *Encyclopædia Britannica*, vol. iv., p. 304.

of rigidity renders them unsuitable for the passage of heavy rolling loads, such as railway trains, unless special and elaborate means be taken for stiffening them. In an ordinary suspension bridge with vertical suspension rods, when a heavy load passes over it, a very sensible deformation of the structure takes place; and when the load passes at a considerable velocity, the stresses produced are much greater than with a statical load of the same amount. It has been found from experience that a regiment of soldiers passing over in step produce oscillations and stresses which in more than one instance have caused the collapse of the structure.

A bridge with inclined suspension rods (Dredge's system) is much stiffer vertically than one in which the rods are vertical.

Oscillations in a lateral direction are produced by the action of the wind, and this alone has in some cases caused the collapse of the bridge. Wind-pressure may also lift the bridge vertically by acting underneath the platform.

343. Stiffening Suspension Bridges.—The lateral oscillations may be retarded, or altogether checked, by efficiently bracing the platform with horizontal diagonal bracing bars. Another method is to attach ties to different parts of the platform at both sides of the bridge, and anchor them to the banks of the river or ravine. These stays may also be used to prevent vertical oscillations. For the latter purpose, instead of being anchored to the ground they may be attached to the piers, in which case they resemble "guy ropes."

A very good method of stiffening, when the bridge is liable to heavy rolling loads, is to introduce into the structure a pair of light lattice girders, which, in addition to stiffening the bridge, act the part of side parapets or screens. These girders may be hung from the main chains by means of the vertical suspending rods, and the cross-beams of the bridge may be attached to their bottom flanges. The ends of these girders should be securely fastened down to the piers to prevent their being lifted by the action of the passing load. Prof. Rankine says * "In order to enable it to act with the greatest efficiency, it should be *hinged* at the middle of the span, which may be effected by making it in two halves, connected together by means of a cylindrical pin of dimensions sufficient to bear the shearing stress, which will presently be stated. The object of this is to annul the straining action which would otherwise arise from the deflection and expansion of the chain.

"This precaution having been observed, the greatest bending

* Rankine's *Civil Eng.*, p. 579.

action on the auxiliary girder will be that due to *half the rolling load*, upon a girder of *one-half of the span of the chain*; and the greatest shearing action, which will take place at the central pin, and at each point of support, will be equal to *one-eighth* of the rolling load over the whole span. That is to say, in symbols—

“ Let w' be the greatest rolling load per unit of span ;
 x , the *half-span* ;
 M , the moment of the greatest bending action on the auxiliary girder ;
 F , the greatest shearing force; then

$$M = \frac{w' x^2}{16} ; \quad . \quad . \quad . \quad . \quad (22).$$

$$F = \frac{w' x}{4} . \quad . \quad . \quad . \quad (23).$$

“ Each half of the auxiliary girder is accordingly to be designed as if for a girder of the span x , under an uniformly distributed load of the intensity $w' \div 2$; regard being had to the fact that such load acts alternately upwards and downwards, so that each piece of the girder must be capable of acting alternately as a strut and as a tie, under equal and opposite stresses.

“ If the girder is not hinged, but continuous, at the middle of the span, it should be made capable of bearing a bending action whose moment is—

$$M = \frac{w' x^2}{14} . \quad . \quad . \quad . \quad (24).$$

Another method of stiffening vertically may be adopted when there are two sets of chains at each side of the bridge, one above



Fig. 250.

the other, by bracing the chains together with diagonal bars (see fig. 250). Rankine says*—“ In order that the two chains may be affected alike by the expansive action of heat, their curvatures should be equal; in other words, their vertical distance

* *Civil Eng.*, p. 580.

apart should be the same throughout the whole span. If that vertical distance be made equal to *half the depression* of each chain, no additional material will be required in the chains beyond what is necessary to support a travelling load over the whole span. The diagonal braces should be capable of acting as struts and ties alternately, under stresses computed as for an auxiliary girder. Material would be saved by this mode of stiffening, as compared with the auxiliary girder; but it would probably be less efficient and durable, as the alteration of the curvature of the chains by heat and cold would tend to strain and loosen the joints of the braces."

Unless the cables made of iron or steel wire are properly cleaned and painted, they are liable to oxidation, and their life is precarious. The ordinary kinds of paint used for wood or iron are quite unsuitable for wire cables, and instead of preserving them, they very often hasten their decay. Owing to the contractions or expansions of the metal, or to variations in the curvature of the cable, the paint gets cracked and water finds its way into the interior of the cable through the interstices and is kept there by the coating of paint. The best substance for coating cables is coal tar, or some substance capable of becoming liquid in hot weather, and thereby adapting itself more readily to the expansion of the cables.

CHAPTER XXVII.

BRIDGES—*continued.*

MOVABLE BRIDGES.

344. Definition.—Movable bridges are, as their name implies, those that are capable of being changed in position. They usually span canals, rivers, or the entrances to docks, and are designed for the purpose of allowing a clear opening or increased headway for the passage of vessels.

As regards the nature of the stresses coming upon them, there is nothing different to what has already been explained; the cantilever principle is more general among them than in ordinary fixed bridges.

345. Different Kinds of Movable Bridges.—There are various

kinds of movements in movable bridges, but the latter may all be classed under the following five different heads :—

1. Those which turn round one or two horizontal axes, and which are termed *draw-bridges* or *bascules* ;
2. Those that turn round one or two vertical axes, and which are termed *swing-bridges* ;
3. Those that roll backwards and forwards horizontally, and which are known as *traversing-bridges* ;
4. Those that lift vertically, or *lift-bridges* ;
5. Those that float in the water, or *pontoon-bridges*.

346. *Bascules*.—The oldest form of movable bridge was the ordinary draw-bridge, which swung in a vertical direction round an axis or pivot at one end. It was constructed of timber, and was generally employed to span a moat round a castle. The opening and closing was effected by means of chains attached to the free end ; these chains passed over pulleys and had counter-balance weights attached to their extremities. A better arrangement is to use a toothed sector in which a pinion works.

When bridges of this kind are made of iron, they are constructed with counterpoised tail-ends so as to diminish the power required to open them. For large spans the bridge may consist of two pieces, one attached to each abutment. Bridges of this latter class, when made of iron, may be conveniently constructed with the bottom member in the form of an arch ; when closed, the extremities of each half-arch will abut against each other, and the whole will form an arched bridge.

347. *Swing-Bridges*.—This is the most important division of movable bridges ; by far the largest number belonging to this class.

Swing-bridges may either be single or double. Single bridges cross only one opening, and consist of a long arm and a short one ; the long arm spanning the waterway, and the short one acting as a counterpoise. In double swings there is a pier in the centre of the waterway, and the two arms bridge the two channels thus formed. The pier may either be of masonry or iron, and its diameter should at least be equal to the width of the bridge. On the top of the pier is laid a circular bearing plate usually made of cast iron. A plate of the same diameter is fixed underneath the bridge, immediately over the former, and a number of turned conical rollers made of iron or, preferably, of steel, are placed between the surfaces. There is also a central pivot, made of steel, attached to the bridge, which fits into a steel socket fixed to the pier ; the motion takes place round this pivot, and is produced by means of a pinion working in a circular toothed

rack by the aid of suitable gearing. The motive power may be manual labour, or, in the case of large bridges, hydraulic power. The rack may either be fixed to the pier or the platform of the bridge. The surfaces in contact with the wheels must be truly planed, and the wheels themselves turned in order to diminish friction as much as possible. In the case of a single swing, the arrangement is precisely the same as that described, except that the turntable is fixed on the abutment, and the bridge has a short arm or tail piece which is loaded with ballast in order to counterbalance the weight of the long arm.

The full advantages of swing-bridges are only obtained when two passages are crossed; in such cases there is no necessity for counterpoises, and, moreover, the effect of the wind on the structure is neutralised, as it acts with the same force on both arms. In a single swing-bridge the short arm and counterpoise are so much useless material, except so far as giving balance to the structure, and it is evident that the wind will produce a much greater effect on the long than on the short arm, which may materially interfere with the opening or closing.

348. Classification of Swing-Bridges.—Mr. J. Price * classifies swing-bridges according to the method by which the weight of the structure is borne while the bridge is being swung.

His classification is as follows:—

- (a.) Those which turn entirely on rollers or wheels.
- (b.) Those where the weight is proportioned, so as in part to be borne by rollers and in part on a centre pivot.
- (c.) Those entirely swung on a centre pivot.
- (d.) Those which are lifted on a water centre by hydraulic power.
- (e.) Those that rest and turn on a water centre, having a constant upward pressure, but not sufficient to lift the whole weight.
- (f.) Floating swings, where the weight is almost entirely buoyed up, having only a small portion on a centre pivot or rollers.

The diameter of the rollers varies considerably in different bridges. In the swing-bridge at Athlone, over the river Shannon, they are only 8 inches, while in the bridge over the passage connecting the east and west floats at Birkenhead the rollers are 5 feet in diameter, being the largest in use under any bridge. Smaller rollers or those from 2 to 3 feet are preferable; when large they frequently break.

For large swing-bridges, it is, as a rule, the best arrangement

* *Proc. Inst. C.E.*, vol. 57.

to have the weight partly borne by rollers and partly by the central pivot. Large American bridges are nearly all constructed on this principle.

Bridges under the division (c), turn entirely on a long centre pivot of a conical form, and of late years they have become very common in Holland.

Bridges under the division (d) are most applicable to single swings; they may be lifted on the water-centre by means of a small hydraulic pump. They are arranged so that one arm of the bridge is slightly heavier than the other, the wheels at one end will then come in contact with the roller plate. When the tail end is the heavier, the rollers bear downwards; and when the other end is the heavier, the rollers bear upwards against an inverted roller path. Several English bridges at dock entrances are arranged on this principle.

An obvious advantage possessed by using lattice-girders for swing-bridges is that they do not offer much obstruction to the action of the wind.

349. Traversing-Bridges.—Traversing-bridges are those which are arranged to roll backwards and forwards like a gangway.

350. Lifting-Bridges.—Lifting-bridges are suspended by the four corners, or the ends of the two main girders, by means of chains which pass over pulleys. The pulleys are attached to four standards usually made of iron. To the ends of the chains are attached counterpoise weights which fit inside the standards. The lifting is usually done by rack and pinion motion worked by manual labour, though for large bridges, hydraulic motive power is preferable.

351. Pontoon-Bridges.—Pontoon-bridges rest on floating caissons or pontoons, and are opened and closed by chains and windlasses. Several bridges of this class cross the Rhine.

CHAPTER XXVIII.

BRIDGES—*continued.*

WEIGHT OF BRIDGES.

352. Importance of knowing the Weight of a Bridge approximately before making the Design.—In designing bridges, one of the first essentials is to know the loads, both live and dead, com-

ing upon them. As a rule, these are all fixed beforehand, except the dead weight of the iron-work of the superstructure, and this weight has, in the first instance, to be assumed. The stresses on the various portions are then calculated, and the sections fixed with this assumed weight. The weight of the iron-work is then determined, and if this weight differ much from the assumed weight, it must be used in making a fresh calculation of the stresses, and in fixing corrected sections. The new weight of the iron-work is then found, and if this differ materially from the first calculated weight, the operation has to be repeated and a fresh adjustment of sections made until a sufficient degree of accuracy be obtained. Generally speaking, one or two such operations only will be sufficient, unless a great degree of nicety be desired. Any information which will enable the engineer to fix approximately the weight of the bridge before making any calculation is of value, as it helps to diminish an amount of laborious calculations.

In order to attain this object, formulæ have been given which apply to bridges of certain types and of given spans and widths, and carrying certain loads. For those who wish to study the subject exhaustively, a great deal of valuable information will be found in a paper written by Max. am Ende.*

353. *Weight of Girders under 200 feet Span.*—Mr. Stoney gives the following rule for determining the weight of girders of ordinary proportions under 200 feet in length :—

Let W = the total distributed load in tons, including the weight of the girder,

l = the length in feet,

d = the depth in feet,

f = the working stress in tons per *square foot* of gross section,

G = the weight of the main girder and end pillars in tons.

$$G = \frac{W l^2}{12 f d} \quad \cdot \quad \cdot \quad \cdot \quad \cdot \quad (1).$$

If W_1 = load on the girder in tons, we get—

$$W = W_1 + G.$$

Substituting this in (1) and reducing, we get—

$$G = \frac{W_1 l^2}{12 f d - l^2} \quad \cdot \quad \cdot \quad \cdot \quad \cdot \quad (2).$$

* *Pro. Inst. of C. E.*, vol. lxiv., p. 243.

By means of this equation we can determine the weight of the girder when the distributed load on it is known.

Example 1.—What is the weight of a wrought-iron girder 150 feet long and 15 feet deep, to carry a distributed load of 250 tons, the metal in the flanges with this load being exposed to a stress of 4 tons per square inch?

Here we have

$W_1 = 250$ tons, $l = 150$ feet, $d = 15$ feet, $f = 4 \times 144 = 576$ tons.

$$G = \frac{250 \times (150)^2}{12 \times 576 \times 15 - (150)^2} = 69.2 \text{ tons.}$$

Example 2.—If, in the last example, the girder be steel and strained to 7 tons per square inch, determine its weight.

In this case

$$f = 7 \times 144 = 1008 \text{ tons.}$$

Substituting in equation (2), we get—

$$G = \frac{250 \times (150)^2}{12 \times 1008 \times 15 - (150)^2} = 35.4 \text{ tons.}$$

From this it is seen that the steel girder is only about half as heavy as the iron one.

354. Weight of Railway Bridges under 200 Feet Span.—Mr. Anderson has given the following rule for determining the approximate weight of railway bridges under 200 feet in length, the depth being $\frac{1}{12}$ of the length, and the working stresses 5 tons per square inch in tension, and 4 tons in compression:—

Let W = total distributed load on the bridge in tons.

w = the weight of the main girders, end pillars, and cross-bracing in lbs. per running foot.

$$w = 4 W. \quad . \quad . \quad . \quad . \quad (3).$$

355. Long-Span Railway-Bridges.—Sir B. Baker* applies the term long-span railway-bridges to all those of 300 feet span and upwards. He refers all bridges of this class to the following types either taken singly or in combination:—

1. Box-plate girders, including tubular bridges.
2. Lattice " " Warren truss, &c.
3. Bowstring " " Saltash type.
4. Straight links and boom. Bollman truss.

* "Long-Span Railway-Bridges" (Baker).

5. Cantilever lattice, uniform depth.
6. " " varying economic depth.
7. Continuous " " "
8. Arched ribs with braced spandrels.
9. Suspension with lattice stiffening girders.
10. Suspended girders.
11. Straight link suspension.

Mr. Baker gives an elaborate series of calculations in order to determine the relative economy of these different types. He also shows how to find the weight of the iron or steel for different spans in terms of the useful load, as well as the absolute weights.

His conclusions are based on the assumption that 4 tons to the square inch represents the working load for wrought iron and 6.5 tons that for steel.

Summarising his results, Mr. Baker finds "that the span of 300 feet, type 11—the straight-link suspension bridge—obtains an advantage of some 20 per cent. over any other system, and that it maintains a certain advantage of diminishing value up to 700 feet span, when it has to resign the lead to type 7—the continuous girder of varying depth—which type maintains a rapidly increasing advantage over all others up to the limiting span. These two forms of construction, then, within their own proper spheres, appear to be the most economical possible, as regards the superstructure of the main span. It is obviously quite possible that in many instances anchorage could not be obtained for the suspension bridge, except at a cost which would render even our heaviest type—the box girder—a more economical form of construction.

"The system ranking second in the scale of economy is type 6, the cantilever lattice girder of varying depth, which maintains its relative position throughout, unaffected by the specific length of the span. Types 9 and 10, the suspension with stiffening girder, and the suspended girder, succeed the last-named one. Although palpably different both in principle and appearance, the respective weights are almost identical throughout, being, up to 700 feet span, little different to the preceding type. We now come to type 5—the cantilever lattice girder of uniform depth—following closely on the heels of the last two systems up to 600 feet span, when it is superseded by type 8—the arched rib with braced spandrels.

"The independent girders, as might fairly be expected, occupy the lowest place on the list, although at 300 feet span type 4—the straight-link girder—shows a slight advantage over the arch.

Within the limits of 400 feet or 500 feet span, the straight link is the most economic form of the independent girder; above that span the bowstring girder surpasses it. Types 2 and 1—the lattice and box girders—conclude the list.”

CHAPTER XXIX.

WIND-PRESSURE ON STRUCTURES.

356. Importance of Wind-Pressure on Structures.—The subject of wind-pressure is a very important one in considering the design of roofs and bridges of large span, or of bridges which are supported on iron piers of great height. A bridge may be carefully designed to carry vertical loads, but, unless the stresses produced by the action of the wind be amply provided for, it may be a very faulty structure indeed. A prominent example of this was in the first bridge which was constructed over the estuary of the Tay, and which was blown down by a gale of wind.

In some structures the stresses produced by the wind-pressure are as great as, or greater than, those produced by the dead or live loads, or even by both combined.

In the case of the principal members of the Forth Bridge, Sir B. Baker has estimated the maximum pressures from the live load, dead load, and wind-pressure to be as follows:—

Stress due to live load,	.	.	1022 tons.
Stress due to dead load,	.	.	2282 „
Stress due to wind-pressure,	.	.	2920 „

357. Circumstances which Influence Wind - Pressure.—The amount of pressure which the wind exerts on a structure of course varies from time to time, both with its velocity and its direction; and the amount and direction of its pressure cannot be determined with anything like the precision that exists in the case of the vertical loads. In fact, the whole question of wind-pressure is in a very unsatisfactory state, and we can only pretend to give information on the subject in a very approximate form.

As has been explained in Chapter XIX., the force which the wind exerts upon a surface is a maximum, when the direction of the wind is normal to the surface; and this, the most unfavourable case, must be assumed in calculating the stresses which it produces on the different members of a structure.

The amount of pressure which the wind exerts on a surface, when its direction is normal to it, depends on two things—

- 1st. The velocity of the wind ;
- 2nd. The shape and character of the surface.

The velocity of the wind can be measured by means of anemometers and other methods. In this way it has been ascertained to reach as much as 100 miles per hour, though it is doubtful if such velocity is ever attained in this country.

358. Relationship between the Velocity and Pressure of the Wind.—The pressure of the wind on a plane surface has a certain definite relationship to its velocity. Most authorities seem to agree that the pressure on such surfaces is proportional to the square of the velocity. Mr. Rouse's formula establishing this relationship, and which has been adopted by Smeaton and others, is

$$p = \frac{V^2}{200} \quad \cdot \quad \cdot \quad \cdot \quad \cdot \quad (1),$$

where p = pressure in lbs. per square foot,
 V = velocity in miles per hour.

Though this formula has been pretty generally adopted, yet its accuracy is disputed by some, and it cannot be regarded as more than approximate. Mr. Hawksley, who has devoted a good deal of attention to the subject, recommends the formula—

$$p = \left(\frac{v}{20}\right)^2 \quad \cdot \quad \cdot \quad \cdot \quad \cdot \quad (2),$$

where p = pressure in lbs. per square foot,
 v = velocity in feet per second.

* This formula has been arrived at somewhat after the following fashion :—

Let v = velocity of a current of air in feet per second,
 h = height through which a heavy body must fall to produce a velocity, v ,
 w = weight in lbs. of a cubic foot of impinging fluid (for atmospheric air $w = 0.0765$ lb.),
 $g = 32$, the coefficient of gravity ;

then, from Newton's law,

$$h = \frac{v^2}{2g}.$$

Since p , the pressure of a fluid striking a plane perpendicularly, and then escaping at right angles to its original path, is that due to twice the height (Rouse's experiment), then

$$p = \frac{w v^2}{g} = \frac{0.0765 v^2}{32} = \left(\frac{v}{20}\right)^2 \text{ approximately.}$$

From these two formulæ the following table has been constructed :—

TABLE CII.—SHOWING RELATIONSHIP BETWEEN THE PRESSURE AND VELOCITY OF WIND.

VELOCITIES.		PRESSURE IN LBS. PER SQUARE FOOT.	
Feet per Second.	Miles per Hour.	Rouse's Formula.	Hawkaley's Formula.
10	6·8	0·23	0·25
20	13·6	0·92	1·00
30	20·4	2·08	2·25
40	27·2	3·70	4·00
50	34·0	5·78	6·25
60	40·8	8·32	9·00
70	47·6	11·33	12·25
80	54·4	14·80	16·00
90	61·2	18·72	20·25
100	68·0	23·12	25·00
110	74·8	27·97	30·25
120	81·6	33·29	36·00
130	88·4	39·07	42·25
140	95·2	45·32	49·00
150	102·0	52·02	56·25

From the table it will be seen that when the wind velocity is 100 miles per hour, which is the greatest that can occur, the pressure is approximately equal to 50 lbs. per square foot. This pressure, however, is too much to assume over large areas. The total wind-pressure upon a surface is not proportional to its superficial area, though it is generally assumed to be so. The

velocity of the stream of wind is not uniform at all points, and the average pressure on a surface of considerable extent is much less than the maximum pressure exerted on small portions of it. This has been verified by experiments recently made in connection with the Forth Bridge. The general result of these experiments shows that the average pressure upon a surface 20 feet by 15 feet is not more than 66 per cent. of that on a small surface $1\frac{1}{2}$ square feet. From this we may assume that as a rule a maximum pressure of 45 lbs. per square foot over the whole surface exposed, is sufficient to allow for structures.

In dealing with lattice-girder bridges, it is usual to allow for the pressure on a surface greater than that represented by the actual area of the girders as seen in elevation. In double-webbed lattice girders the area of both webs should be taken, or double the web area as seen in elevation, for if the direction of the wind varies ever so little from being normal to the girder, the first set of lattice bars give little or no shelter to the second. If a bridge consist of two such main girders, the wind-pressure on both girders must be allowed for, so that the pressure must be taken as acting on an area equal to *four times* that as seen in elevation.

The destruction of the first Tay Bridge has been the means of directing the attention of engineers more closely to this subject. A committee appointed by the Board of Trade to consider the question, recommended :—

1. That in exposed situations the maximum pressure to be provided for shall be 56 lbs. to the square foot of surface.
2. That, for open lattice-work, the surface on which this pressure acts should be from once to twice the front area, according to the openings in the lattices.
3. That, for iron or steel work, a factor of safety of four should be provided; and, considering the tendency of the bridge as a whole to be overturned, a factor of safety of two should be allowed.

American engineers assume a wind-pressure of 30 lbs. per square foot upon the loaded, and 50 lbs. upon the unloaded structure. Their specifications usually provide for a pressure of 30 lbs. per square foot on the train surface, and twice the vertical surface of one truss, or, as an alternative, 50 lbs. per square foot on the unloaded bridge; and it is further specified that the maximum stresses on the wrought iron under these conditions must not exceed 15,000 lbs. per square inch in tension, 10,000 lbs. in

shear, and one-fourth the ultimate resistance in compression. It is usual for the iron piers to have such a width of base that, with the above pressures, there will be no tensile stress on the main pillars.

359. Influence of the Form of a Surface as affecting Wind-Pressure.—The *form* of a surface exposed to the wind has a great deal to do in modifying the pressure exerted against it. The pressure, for example, upon *convex* surfaces is much less than that upon their projected plane surfaces, and that on *concave* surfaces is much greater.

From theoretical calculations it appears that the pressure upon a sphere is only *one-half* that on a flat surface, equal in area to a section through its centre, and that upon a solid cylinder is only *two-thirds* of the pressure on a section through its axis. On the other hand, the pressure on a parachute is nearly double that on its diametral section.

If great nicety of calculation be desired, a coefficient of 0.5 should be taken for all round bars, and a coefficient of 1.5 for channel sections. It is not often, however, that such exactness is necessary.

360. Wind-Bracing.—In order to provide against the wind-pressure exerted on the superstructure of a bridge, the main girders should be braced together in a horizontal direction, by which means the pressure is transmitted to the abutments. This bracing, except in very deep girders, occurs at the bottom flanges. If the floor of the bridge consists of wrought-iron plates resting on cross girders, or of wrought-iron or steel troughing, such flooring in itself fulfils all the requirements of the wind-bracing. When the floor consists of timber it will be necessary to introduce diagonal bracing of wrought iron. With deep girders which admit of sufficient headroom, the top booms should be connected by arched or diagonal bracing.

Arched bridges do not need so much wind-bracing as those constructed of ordinary girders, as they expose little surface at their centres where the wind-pressure exerts the greatest effect.

361. Stresses on Braced Piers.—Fig. 251 is an example of a braced pier. Under ordinary conditions it will be exposed to two sets of forces, namely:—

1. *Vertical forces*, which consist of the weight of the pier itself together with that of the superstructure and the live load.

2. *The horizontal wind-pressure.*

In calculating the working stresses produced by these external

forces, it will not be necessary to take into account any live load on the bridge, as with a wind-pressure of from 40 to 50 lbs. per square foot it would not be possible for railway trains or other vehicles to pass over.

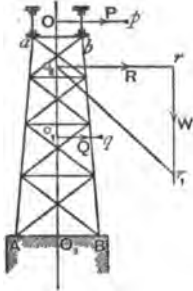

Fig. 251.

The wind-pressure (P) exerted on the superstructure may be represented by a line, $O p$, which passes through the middle of the depth of the main girders.

The wind-pressure (Q) exerted on the pier may be represented by a line, $o_1 q$, which passes through the centre of the surface of the pier exposed to the wind.

The resultant (R) of these two pressures is represented by a horizontal line, $o_2 r$, where $o_2 r = O p + o_1 q$. The point of application of this force is at the point o_2 , where $O o_2 : o_2 o_1 :: Q : P$.

The vertical force (W) coming on the pier acts along the central line $O o_2 o_1$. Through the point r draw the vertical line $r r_1$, making $r r_1 = W$. Join $o_3 r_1$; this line will represent both in magnitude and direction the resultant of all the forces acting on the pier. If the line $o_3 r_1$ produced fall *between* the points A and B the pier will not be overturned, even though it be not anchored down. If $o_3 r_1$ fall *outside* A B the pier will be liable to be overturned unless anchored down.

In the latter case if the pier be anchored at A, the stress on the anchor-bolts may be found thus—

Let R = resultant of the wind-pressures.

$o_2 O_3 = b$, the distance of its point of application from the base of the pier.

W = vertical load on the pier including the weight of the pier itself.

$a = A O_3 = O_3 B$ = half the base of the pier.

S = stress on anchor-bolts at A.

Taking moments about B as a fulcrum, we get—

$$S \times 2 a + W \times a = R \times b.$$

$$S = \frac{R b - W a}{2 a} \quad \dots \quad (3).$$

In a similar manner may be found the stresses on a A and b B, the main pillars of the pier.

When there is a tensile stress on the anchor-bolts at A, the member A a will be in tension and b B in compression.

When there is no stress on the anchor-bolts at A, there will be compressive stresses both on a A and b B, though not equal in amount.

The stresses on the lattice-bracing of the pier may be found in a similar manner to those on a braced cantilever loaded with a concentrated weight at its extremity, and a practically uniformly distributed load over its entire length.

In order to further illustrate the effects of wind-pressure on braced piers, we cannot do better than give an example of a pier actually in existence—namely, one of the high piers of the Boule viaduct—an account* of which is given by M. Jules Gaudard of Lausanne.

This viaduct consists of a series of spans of 164 feet each; the main lattice girders are 14 feet 9 inches deep. Each pier consists of four cast-iron columns, which are ballasted with concrete and braced together, as shown in fig. 251; the height of the top of the girders from the base of the pier is 203 feet 5 inches. The vertical loads on each pier are as follows:—

Dead weight of one span,	120 tons.
Weight of train,	85 "
Weight of pier,	240 "
	—
Total load on pier,	445 "

Taking a wind-pressure of 55.3 lbs. per square foot, the total pressure against a girder, allowing for the spaces between the lattices, will be about 40 tons. This pressure acts horizontally midway between the top and bottom of the girder, or at a height of 196.2 feet above the base of the pier.

The pressure on the train is estimated at 32.4 tons, and this acts horizontally at a height of 210.3 feet above the base of the pier. Lastly, the wind-pressure on the pier is estimated at about 40 tons acting horizontally at a height of 92.85 feet above the base.

We have now all the data necessary for determining the stresses on the pier under the above conditions.

As the width of the base of the pier is 67 feet 7 inches, we get—

Moment of stability of pier = $445 \times 33.8 = 15,041$ foot-tons.

Moments of wind-pressure tending to overturn pier
 = $40 \times 196.2 + 32.4 \times 210.3 + 40 \times 92.85 = 18,375.72$ foot-tons.

From which it is seen that the net overturning moment
 = $18,375.72 - 15,041 = 3,334.72$ foot-tons.

**Proc. Inst. of C.E.*, vol. lxi.

It will be necessary, therefore, to anchor the pier down to its foundations. If the anchor-bolts pass through the extremity of the base of the pier, and if S = total tension on the bolts, we get—

$$S \times 67.6 = 3,334.72, \text{ or } S = 49.3 \text{ tons.}$$

CHAPTER XXX.

LIFTING TACKLE, ERECTION OF BRIDGES, ETC.

LIFTING TACKLE.

362. Derricks.—A derrick is usually a pole or balk of timber placed in an upright position, one end resting on the ground. When the weight to be lifted is great, or when the derrick is long, the latter may be made of wrought iron, either square or circular in cross-section, and formed of continuous plates and angles or open lattice-work. Derricks are kept in a vertical position by means of ropes or chains fastened to their tops, the other ends of the stays being anchored to the ground or made fast to objects in the vicinity. These stays are termed *guy ropes* or *guy chains*; and the efficiency of the derrick depends to a large extent upon them. The dimensions of a derrick-pole depend upon its height and the weight to be lifted. For light weights a balk of timber 8 inches to 12 inches square is usual; for heavier weights, 12 to 18 inches square may be required. For anything beyond this it is advisable to use wrought iron. For lifting heavy weights, chains are preferable to ropes for staying, and these should not be less than four for each derrick. The bottom end of the stay may be fastened to stakes driven into the ground. A convenient arrangement for this purpose is a wrought-iron bar with an eye forged on one end and a screw on the other. This can be screwed into the ground by inserting a round bar in the eye and using it as a lever. This is afterwards withdrawn and the guy made fast to the eye. At the top of the derrick a pulley-block is attached, and the chain or rope for hoisting passes round the pulley and is carried down the side of the derrick to a snatch block fastened to its heel, and then passes round the barrel of a crab placed at some distance off and anchored to the ground. When a single derrick

is used for lifting heavy weights, say over 15 tons, it is advisable to employ two sets of pulleys and tackle. For long and heavy girders, two derricks may be used, the girder being slung from two separate points.

363. Sheer Legs, Tripods, and Scotch Cranes.—Other lifting apparatus are *sheer legs* and *tripods*. The former consist of two poles and require two or three guy ropes, while the latter consist of three poles and do not require any guys.

These latter are not so convenient for shifting from one place to another as ordinary derricks. What is known as the *Scotch crane* is a very useful appliance for lifting purposes. The gib can be raised or lowered in a vertical plane, or swung round in a horizontal plane, so that the work lifted may be placed in its required position. The lifting crabs may be worked by steam—instead of hand-power when heavy weights are being lifted.

The method of determining the stresses on all these lifting appliances is fully explained in Chap. XVI.

364. Ropes and Chains.—Ropes are usually made from “green hemp” or manilla. They are measured by their circumference in inches and are generally sold by weight.

There are several rules for calculating the strength of ropes, but they must be considered only as approximate, there being considerable variation in the strength of pieces even when cut from the same coil. One rule is, that *the breaking stress in cwts. is equal to four times the square of the girth in inches*; so that if

c = circumference in inches,
 S = breaking stress in cwts.

$$S = 4 c^2 \quad . \quad . \quad . \quad (1).$$

This is a very approximate rule, and is applicable only to certain qualities of rope.

The following formulæ are more to be relied upon, and can be made applicable to the different kinds of rope by using the proper constants:—

Let c = circumference of rope in inches,
 l = working load in tons,
 s = breaking stress in tons,
 w = weight of rope in lbs. per fathom.

k , x , y , and z are constants.

$$c = \sqrt{\frac{l}{k}}, \quad s = c^2 x, \quad w = c^2 y, \quad w = l z.$$

TABLE CIII.—THE VALUES OF *k*, *x*, *y*, AND *z* (MOLESWORTH).

DESCRIPTION OF ROPE.	<i>k</i>	<i>x</i>	<i>y</i>	<i>z</i>
Common hemp,	·032	·18	·18	6·0
Coir, hawser laid,	·131	...
Coir, cable laid,	·117	...
St. Petersburg tarred hemp hawser,	·037	·22	·235	6·35
St. Petersburg tarred hemp cable, .	·025	·15	·207	8·28
White manilla hawser,	·045	·27	·177	3·93
White manilla cable,	·033	·19	·155	4·70
Best hemp "cold register,"	·100	·60
Best hemp "warm register,"	·116	·70

TABLE CIV.—WORKING STRENGTHS AND WEIGHTS OF HEMP ROPES.

Circum. in inches.	Working Stress in Tons.		Weight in lbs. per Fathom.		Circum. in inches.	Working Stress in Tons.		Weight in lbs. per Fathom.	
	Common.	Good.	Common.	Good.		Common.	Good.	Common.	Good.
1	·032	·046	·18	·24	4½	·578	·831	3·25	4·34
1½	·050	·072	·28	·38	4¾	·648	·932	3·65	4·86
1¾	·072	·104	·41	·54	4¾	·722	1·038	4·06	5·42
1¾	·098	·141	·55	·74	5	·800	1·150	4·50	6·00
2	·128	·184	·72	·96	5½	·968	1·392	5·45	7·26
2¼	·162	·233	·91	1·22	6	1·152	1·656	6·48	8·64
2½	·200	·288	1·13	1·50	6½	1·352	1·944	7·61	10·14
2¾	·242	·348	1·36	1·82	7	1·568	2·254	8·82	11·76
3	·288	·414	1·62	2·16	7½	1·800	2·588	10·13	13·50
3¼	·338	·486	1·90	2·54	8	2·048	2·944	11·52	15·36
3½	·392	·564	2·21	2·94	8½	2·312	3·324	13·05	17·34
3¾	·450	·647	2·53	3·38	9	2·592	3·726	14·58	19·44
4	·512	·736	2·88	3·84	10	3·200	4·600	18·00	24·00

The breaking stresses are about five times the working loads, as given in the last table.

365. Preserving Ropes.—Ropes are liable to rapid deterioration unless kept dry and free from dirt. If they are exposed to constant wet it is advisable to tar them; this renders them more durable though it may to some extent diminish their strength. Another cause of deterioration is the wear and tear caused by passing round barrels and pulleys; the strands also in such cases become unequally strained, those on the outer side of the rope being exposed to greater tension than those in contact with the pulley. This inequality of stress is reduced by enlarging the diameters of the pulleys.

If ropes are kept a long time without using them, they should be carefully examined and tested before use.

366. Chains.—Chains are usually made out of round wrought-iron bars of the best quality. The links may be of different forms, that approximating to the ellipse being the most common. Generally speaking, chains are of two sorts—the *close-link chain*, and the *studded-link chain*. In the *stud-link chain*, a stud or stay usually made of cast iron is inserted across the shorter diameter of each link, in order to prevent the sides closing under heavy stresses.

The size of a chain is measured by the diameter of the bar from which it is made; thus, a $\frac{3}{4}$ -inch chain is made from round bar $\frac{3}{4}$ inch in diameter.

When a direct tension is applied to a chain, each link is subjected to a bending as well as a tensile stress; the bending action being greatest at the extremities of the links. Each link has to be welded, which materially diminishes its strength; this diminution of strength amounting on the average to about 20 per cent. of the strength of the bar.

Chains which pass over pulleys are subjected to other bending stresses. In such chains the links should be made as small as possible, in order to increase the flexibility of the chain, and to diminish the bending action above referred to. From experiments made on chains at Woolwich, it was found that a studded chain cable broke with a mean tension of 15.9 tons per square inch, and a close-link chain broke with a tension of 17.5 tons per square inch. The strength of the iron from which these chains were made was about 26 tons. The reduction of strength is to be accounted for by the welds and the bending stress.

367. Fatigue of Chains.—Chains which have been in use some time suffer from "fatigue," the material often becoming crystalline in its texture. By annealing the chains periodically, the

equilibrium of the material becomes restored, and its strength

re-established. It is a rule of the War Department that all chains of cranes, slings, &c., be thus annealed from time to time.

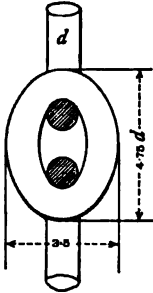

Fig. 252.



Fig. 253.

Fig. 252 shows the ordinary proportions of a close-link chain in terms of the diameter of the metal from which the chain is made. The inside radii of the ends of the link must be a little greater than the radius of the bar from which the chain is made.

Fig. 253 shows the ordinary proportions of the link of a studded chain. The stud, especially in large links, adds considerably to their strength.

368. **Ultimate Stress, Proof Stress, and Working Stress on Chains.**—When speaking of the stresses applied to chains, three kinds are to be distinguished, viz. :—

The Ultimate Stress.

The Proof Stress.

The Working Stress.

Approximately, the proof stress is about one-half the ultimate strength, and the working stress is about one-half the proof stress. Strictly speaking, however, the working stress ought to vary with the use to which the chain is put. If subjected to vibrations and shocks this stress should not be greater than one-third the proof stress.

The Admiralty rules for studded chain cables and close-link crane chains are as follows :—

Let d = diameter of the iron forming the chain ;

For studded chain cables—

Proof load in tons = $18 d^2 = 11\frac{1}{2}$ tons per sq. in. of section.

For close-link crane chains—

Proof load in tons = $12 d^2 = 7.7$ tons per sq. in. of section.

If the working load be taken at one-half the proof load, we get—

For studded chains—

Greatest working load = $9 d^2 = 5.75$ tons per sq. in. of section ;

For close-link chains—

Greatest working load = $6 d^2 = 3.85$ tons per sq. in. of section.

369. Weight of Chains.—The weight of chains in lbs. per foot may be expressed by the equation—

$$w = 9 d^2 \quad . \quad . \quad . \quad (2).$$

The following tables are given by Mr. Unwin, the breaking strength being calculated from the Woolwich experiments.

TABLE CV.—STRENGTH AND WEIGHT OF CLOSE-LINK CRANE CHAINS, AND SIZE OF EQUIVALENT HEMP CABLE.

Diameter of iron d in inches.	Weight of chain per fathom.	Breaking strength in tons.	Testing load in tons.	Girth of equivalent rope in inches.	Weight of rope in lbs. per fathom.
$\frac{1}{4}$	3.5	1.9	0.75	2	$1\frac{1}{2}$
$\frac{5}{16}$	6.0	3.0	1.10	$2\frac{1}{2}$	$1\frac{1}{2}$
$\frac{3}{8}$	8.5	4.3	1.6	$3\frac{1}{2}$	$2\frac{1}{2}$
$\frac{7}{16}$	11.0	5.9	2.3	4	$3\frac{3}{4}$
$\frac{1}{2}$	14.0	7.7	3.0	$4\frac{3}{4}$	5
$\frac{9}{16}$	18.0	9.7	3.8	$5\frac{1}{2}$	7
$\frac{5}{8}$	24.0	12.0	4.6	$6\frac{1}{2}$	$8\frac{1}{2}$
$\frac{11}{16}$	28.0	14.6	5.6	7	$10\frac{1}{2}$
$\frac{3}{4}$	31.5	17.3	6.8	$7\frac{1}{2}$	12
$\frac{13}{16}$	37.0	20.4	7.9	$8\frac{1}{2}$	15
$\frac{7}{8}$	44.0	23.1	9.1	9	$17\frac{1}{2}$
$\frac{15}{16}$	50.0	26.1	10.5	$9\frac{1}{2}$	$19\frac{1}{2}$
1	56.0	29.3	12.0	10	22
$1\frac{1}{8}$	71.0	36.3	15.3	$11\frac{1}{2}$	$27\frac{3}{4}$
$1\frac{1}{4}$	87.5	44.1	18.8	$12\frac{1}{2}$	$34\frac{1}{2}$
$1\frac{3}{8}$	105.8	52.8	22.6	$13\frac{3}{4}$	$41\frac{1}{2}$
$1\frac{1}{2}$	126.0	62.3	27.0	15	$49\frac{1}{2}$

TABLE CVL.—STRENGTH AND WEIGHT OF STUDDED-LINK CABLE.

Diameter of Iron d in Inches.	Weight in Lbs. per Fathom.	Breaking Strength in Tons.	Test Load in Tons.	Girth of Equivalent Rope in Inches.	Weight of Rope in Lbs. per Fathom.
$\frac{3}{8}$	24	9.5	7	$6\frac{1}{2}$	9
$\frac{7}{16}$	28	11.4	$8\frac{1}{2}$	$7\frac{1}{2}$	12
$\frac{1}{2}$	32	13.5	$10\frac{1}{4}$	8	14
$\frac{5}{8}$	44	20.4	$13\frac{1}{4}$	$9\frac{1}{2}$	$19\frac{1}{2}$
1	58	24.3	18	$10\frac{1}{2}$	$22\frac{1}{2}$
$1\frac{1}{8}$	72	29.5	$22\frac{1}{2}$	12	$30\frac{3}{4}$
$1\frac{1}{4}$	90	38.5	$28\frac{1}{4}$	$13\frac{1}{4}$	$39\frac{1}{2}$
$1\frac{3}{8}$	110	48.5	34	15	$48\frac{1}{2}$
$1\frac{1}{2}$	125	59.5	$40\frac{1}{2}$	16	55
$1\frac{5}{8}$	145	66.5	$47\frac{1}{2}$	17	62
$1\frac{3}{4}$	170	74.1	$55\frac{1}{2}$	18	$68\frac{1}{2}$
$1\frac{7}{8}$	195	92.9	$63\frac{1}{4}$	20	86
2	230	99.5	72	22	104
$2\frac{1}{4}$	256	112	$81\frac{1}{4}$	24	124
$2\frac{1}{2}$	285	126	$91\frac{1}{2}$	26	145

ERECTION OF BRIDGES, &c.

370. In the erection of iron or steel bridges there are almost as many systems as there are designs of bridges themselves, and to a certain extent each bridge must be considered on its own merits. The erection of a bridge is sometimes the most difficult part of the undertaking, and in making his design the engineer should try to arrange it so as to facilitate the erection as much as possible.

In bridges of small span crossing roadways or railways the erection is an easy matter, and resolves itself merely into a question of lifting. When there is convenient roadway or railway

accommodation to the site, girders of lengths up to 80 feet, and weights up to 20 tons may be delivered at the site in one piece. If they exceed these limits they may be sent in two or more pieces, and afterwards rivetted together in position. In such cases the joints should be so arranged that the different lengths can be conveniently joined together. When the girders are too large to be treated in this manner, or where there is a difficulty in transporting heavy pieces to the site, or of lifting them into position, then it becomes necessary to send the work away in small pieces, and all or most of the jointing and rivetting has to be done on the site by erecting the work on a stage or otherwise. In cases of this kind it is always advisable in the first instance to erect the girder complete in the bridge-builder's yard so as to insure everything fitting properly. The different bars, plates, &c., should then be carefully marked, and corresponding marks put on the erection drawing, so that each piece may find its proper place at the final erection *in situ*. A complete list of bolts, rivets, and other fastenings should be made, and a copy furnished to the foreman in charge. Attention to this will save a deal of trouble. It is customary to send an excess of about 10 per cent. of all rivets in order to provide for those lost or burnt.

371. Erection of Small Bridges.—In bridges of small span, where the girders are delivered on the site complete, it is only necessary to erect one or two derricks according to the size of the girders, by means of which the latter may be lifted to their place. The cross-girders are similarly treated and then the flooring laid, no scaffolding being necessary.

If the main girders are delivered at the site in two pieces, they may be jointed together on the ground, and then lifted complete in the manner explained. If too heavy or cumbersome for thus treating, a timber trestle may be erected towards the centre of the span, then each piece lifted and laid with one end on the abutment and the other on the trestle, and the two pieces rivetted together in this position. This method is very inexpensive, as little or no scaffolding is needed.

372. Erection of Large Bridges.—In bridges of large span, or where a river or ravine has to be crossed, other methods will have to be adopted. These have been very fully considered by Mr. Seyrig,* and a good deal of the subsequent information on this subject is due to him.

The different methods of erecting large bridges may be grouped under four heads:—

* *Pro. Inst. of Civil Engineers*, vol. lxiii.

1. *Erection upon Staging ;*
2. *Erection by Floating ;*
3. *Erection by Protrusion, or Rolling Over of Girders ;*
4. *Erection by Overhanging, or Building Out.*

373. Erection upon Staging.—This is by far the most common way of erecting bridges, though it is often expensive. The staging is usually constructed of timber, and, roughly speaking, consists of a series of timber trestles or piers upon which are laid longitudinal balks or beams. On these latter are placed a series of cross-beams which, in their turn, support the longitudinal planking, which latter forms a platform for the men to work upon. The stage, in fact, is a temporary wooden bridge.

The bottom boom of the girder is first laid on the stage resting on a series of skids and wedges, by means of which the proper camber is given to it before the web and top flange are erected. If the bridge crosses a river it will be necessary, in order to form the temporary piers, to drive piles securely into the river-bed, so that the scaffolding may not be swept away by the force of the current.

The sections of the various scantlings in the stage have to be determined specially in each case. As a rule, when the trestles are more than 30 feet apart, it will be necessary to truss the main longitudinal beams by means of wrought-iron tie-bars. The working stresses allowed to come on a temporary structure of this kind are much greater than those in permanent structures. In the former case it is not unusual for the working stress to be *one-half* the ultimate strength.

A Scotch crane, fixed on the stage, is very useful for lifting purposes. It is also often convenient to have a Goliath travelling crane running the whole length of the stage on rails placed at each side of the girder, by means of which the different members may be placed in position.

374. Erection by Floating Girders.—There are several varieties of sites which do not lend themselves to the construction of a stage. In deep or rapid rivers, or those subject to floods, the construction of a stage is troublesome and often impossible. In navigable rivers, also, it may interfere with the passing of vessels. In such cases some other method must be adopted.

The main girders may be built on the shore and then rolled on to pontoons and floated to their destination. The erection of the main tubes of the Britannia tubular bridge was done in this way. The tubes were constructed on a platform, which was erected on piles close to the shore. When the tubes were ready,

pontoons were brought underneath them through the piles at low water; when the tide rose the tubes were lifted bodily off the scaffold and floated to their position between the piers. By letting water into the pontoons, the tubes were lowered on to the masonry piers which were above water. The tubes were afterwards lifted 6 feet at a time by powerful hydraulic presses placed on the piers. After each lift the masonry was built up underneath, and then a fresh lift was made, and the operation of building the masonry continued, by which means they were eventually got to their proper level. The weight of the four large tubes, which were 470 feet long, was 1587 tons each, and they were fixed at a height of 100 feet above water-level. Six pontoons were used for floating each tube.

375. Erection by Protrusion, or Rolling Over of Girders.—This method is principally applicable to continuous girders extending over several spans, and dispenses with the necessity of staging. It is important when this plan of erection is to be carried out that the girders be designed so as to make it practicable. When a girder projects in the form of a cantilever, severe stresses are incurred of a nature and intensity to which it will not be exposed when fixed in its final position. In order to provide against these temporary stresses, it is sometimes necessary to make the girder stronger in certain parts than is needed in the permanent structure. The extra strength and stiffness are sometimes provided for by means of temporary bracings and stays, which are removed after the girder is finally fixed in position.

There are several advantages attending this system of erection. The bridge may be put together on the bank, and the operation of rolling it over is not, as a rule, attended with much risk or expense if properly carried out. It is equally applicable to lofty viaducts and bridges crossing rivers.

Fig. 254 explains how a girder A B, continuous over three spans, may be rolled across into its final position. The girder rests on rollers which should be grooved so as not to interfere with the rivet-heads in the bottom flange, or the rollers may revolve in a frame fixed to the girder and run on a rail laid on the ground. A crab, C, is fixed on the opposite bank, and a chain from it fixed to the extremity B of the girder.

If the girders are deep and narrow, and rolled over separately, they should be fixed in a cradle to prevent their falling over sideways.

In order to prevent an undue side-stress on the piers, a tie might be taken from the top of the pier and fastened to the bank from which the girder is rolled.

Fig. 255 explains a method applicable when there are no piers. A crane, C, is fixed on the opposite bank to that on which the girder rests. This supports the end B while the girder is being rolled across. A counterbalance weight, A, is often used in order to relieve the stress on the crane. By applying levers or jacks to the end A, the girder may be pushed over. Instead of the bridge, the staging may be rolled across; in some cases this will be found preferable, but should only be had recourse to when other methods are not applicable, on account of the expense

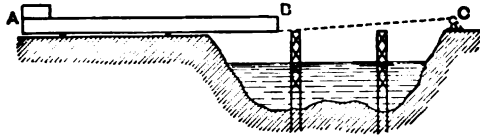

Fig. 254

involved. The stage in such case may be constructed of timber lattice-trusses, connected together with cross-framing.

In bridges crossing rivers and canals, a method of erection might in some cases be employed with advantage, which is a combination of the methods of rolling and floating. The girder is first thrust forward to nearly one-half its length. A boat is then placed under the projecting end, which can be raised by pumping water out of the vessel; the girder can then be drawn over and landed on the opposite abutment.

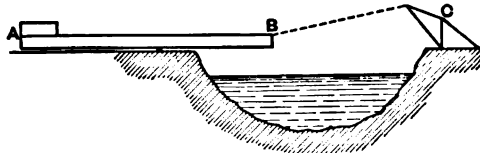

Fig. 255.

376. Erection by Overhanging, or Building Out. — By this system no scaffolding whatever is required, the structure itself being made use of for its own erection. This plan is adopted in situations where it is impossible to erect staging, and where the design of the structure lends itself to the method, such as braced arches or bridges of the double cantilever form. Among notable examples, where this method has been successfully adopted, may be mentioned the Forth and Douro Bridges.

The bridges are built out, starting at the abutments or piers.

In the case of a bridge with a single span, the erection is started at each abutment, and built out panel by panel until the two portions meet at the centre. The top members of each portion must be tied back to the abutment, while the lower members may for a certain distance be supported by inclined struts.

In bridges with more than one span, by starting at a pier and building out on either side simultaneously, two cantilevers are formed which balance each other.

377. Cost of Erection.—The cost of erection of bridges varies a great deal, and may be roughly stated to be from £1 to £10 per ton. When a great deal of rivetting has to be done, it is advisable to use portable rivetting machines driven either by hydraulic or pneumatic power; the latter being preferable in cold climates, as it is not interfered with by the frost.

After a bridge has been erected and before it is opened to traffic it should be tested and the deflection noted. In railway bridges it is usual to send a string of locomotives coupled together over it at different speeds.

378. Erection of Iron Roofs and Buildings.—If a roof rests on columns, the first thing to be done is to fix these in position. The foundation of a column may simply consist of a stone bedded in the ground, it is best, however, to have concrete or brickwork underneath the stone to insure the stability of the foundation, and the tops of the stones should be dressed off smooth and level.

The columns may be fixed to the foundations by Lewis' bolts, which latter are fixed to the stone by running them with lead, sulphur, or other suitable substance. When lead is used it is poured into the dovetail space between the bolt and the stone, and, to make a good job, it should afterwards be caulked as the lead contracts in cooling. Sulphur does not require caulking as it expands in cooling. In the case of long columns, which require extra anchorage, long bolts should be used which pass down through the concrete or brick foundation, and are secured thereto by anchor plates. It is usual to have four holding-down bolts for each column.

For good work the bases of the columns should be faced; when this is not done one or more layers of felt or a layer of sheet lead should be placed between the column and the stone. These packings will yield wherever the pressure is greatest, so that it becomes distributed approximately over the base. Another plan for packing the bases of columns and getting them truly vertical is to put iron wedges at the different corners; then by driving one or other of these wedges, the column may be made quite plumb. When all the columns are thus set true, and their tops

brought in line, the space between the column base and the stone may be filled in with molten lead, or sulphur, or Portland cement, or it may be caulked with iron borings. It is very important that the columns be made to bear evenly over the entire surface of their bases. Many cases have been known where this has not been attended to, where the base of the column (or the stone itself) has been cracked (see Art. 153).

When the columns have been fixed and before they are finally bolted down, the connecting girders, when there are any, for carrying the principals should be lifted into their place by means of a derrick and bolted to the columns. There is little difficulty in lifting girders in this way, as they are stiff and not liable to buckle. It is different, however, in lifting principals on account of their want of lateral stiffness. If the principals are small the derrick chain may be attached to a single point, namely, the crown. It is preferable, however, to have the chain-sling attached to two points. In larger trusses two derricks may be necessary, and there should be two or more points of attachment. When a roof truss is suspended in this way it is exposed to stresses it was never designed to bear, the main tension members being subjected to compressive and the rafters to tensile stresses. In order to prevent the ties from buckling they should be stiffened by lashing light timber poles to the truss.

When the first principal is lifted, it should be securely fixed to the ground or some fixed object by means of ropes or chains, before it is released from the derrick. As each successive principal is lifted, it is lashed to the preceding one until the purlins are fixed. It is also advisable to attach the wind-ties as the work proceeds. Many accidents have been known to occur by neglecting these precautions. A gale of wind suddenly springing up has blown down many a partially-erected roof when the principals were not properly stayed or braced together.

Sometimes the covering is not put on until the whole of the framework is fixed, but the more usual plan with large roofs is to proceed in laying the covering as each bay of ironwork is completed.

Arched ribs may be lifted in one or more pieces according to the span. When in three pieces, the abutment ends are first lifted and fixed, and then the centre pieces dropped in and the connections made good. This may, as a rule, be done without any elaborate scaffolding, except in the case of very large spans, when it becomes necessary to build a stage from the ground and erect the ribs upon it. It is not necessary for the stage in such cases to extend the whole length of the roof, it being usually

made about the width of two bays, and arranged so as to travel longitudinally with the roof by running on rails laid on the ground. The same staging is used for fixing the purlins and the covering.

After the framing and covering have been fixed, the last process is the painting of the roof. The number of coats which the iron and timber work receives is usually three, though four coats are sometimes specified. The first coat is usually put on before the work leaves the contractor's yard, the remaining coats after the work is fixed.

CHAPTER XXXI.

ENGINEERS' SPECIFICATIONS OF IRON AND STEEL BRIDGES.

THE two following are examples of engineers' specifications, so far as they apply to the iron and steel work of bridges and roofs. They are selected with care, and are examples of the most recent work:—

MANCHESTER, SHEFFIELD, AND LINCOLNSHIRE RAILWAY.

Extracts from Specification for Bridge Work, October, 1889.

CAST-IRON WORK.

1. **Cast Iron.**—The cast iron must be of the best grey metal, free from cinder or graphite; the castings must be free from air-blows, honeycomb, sand, or other flaws, and the quality shall be such that a bar, 4 feet long by 1 inch wide and 2 inches deep, placed on solid supports, giving a clear span of 3 feet 6 inches, shall carry, without showing any signs of fracture, not less than 3000 lbs. placed in the centre of the bar between the supports.

2. **Castings.**—The castings must be clean and neat, not buckled or in any way defective, and must be in exact accordance with the drawings. All patterns must be approved before being cast from, and special care must be taken with those for the parapets. All castings when complete shall be submitted to any test that the engineer may think it necessary to apply, and any casting which may prove defective shall be replaced by another of approved quality, at the contractor's cost.

3. All bolt-holes must be drilled true to a template, and, except when otherwise specified, no cast holes will be allowed. The diameter of the

484 ENGINEERS' SPECIFICATIONS OF IRON AND STEEL BRIDGES.

holes must not exceed that of the bolts by more than one-sixteenth of an inch.

4. All joints not specially shown on the drawings to be faced shall be provided with chipping pieces, and accurately fitted. The joints and bearing surfaces of cylinders for bridge or other foundations shall be accurately faced in the lathe.

5. No casting shall be painted until it has been examined and approved by the engineer or his inspector, after which it shall be thoroughly scraped clean, and well painted with four coats of Colley's Torbay or other approved paint. Any casting in which plugging or other attempts to conceal defects may be discovered will be at once rejected.

WROUGHT-IRON WORK.

6. **Wrought Iron.**—All iron shall be of best Staffordshire or other equally approved British make, and samples, selected from the bulk by the engineer or his inspector, shall be capable of withstanding in University College, London, or other approved machine, the following tests :—

TABLE CVII.

Description of material.	Tensional breaking strain in tons per sq. in. not to be less than	Contraction of area at fracture: average per cent. not to be less than	Elongation per foot.
Wrought-iron bars, L- and T-iron, . . }	22	20	1½ inches.
Wrought plates, lengthway, . . }	21	10	¾ "
Wrought plates, crossway, . . . }	18	4	½ "
Wrought bolts, nuts, rivets, . . }	23	30	2½ "

7. All rivets must be of best Yorkshire iron, capable of being bent double cold without fracture, and must be made out of the solid. Except where countersunk, the rivet heads are to be cupped, and they shall be free from cracks or other defects.

8. **General.**—All plates shall be of uniform thickness throughout, and carefully curved or bent to the required forms. All bars, plates, angles, and tees shall be of the sizes shown on the drawings, and placed in the work

so that the fibres of the iron may run in the direction of the greatest strain. The edges of all plates shall be planed, and all joints shall be true and close butts. The ends of all angle- or tee-iron stiffeners shall be cut square, and neatly dressed in a machine-saw or otherwise. The work must be prepared and the holes marked from proper templates, so as to insure a uniform width of plates in the flanges, and accurate correspondence of rivet-holes through the several thicknesses. The rivet-holes shall be drilled. The rivets must be made to well fill the holes, and rivetted by machine power whenever practicable, and must be countersunk when ordered. All angles and cranks must be neatly formed with easy curve, and the work must be free from cracks, scales, ragged edges, and flaws of every kind. All girders must be built with a proper camber on the under side, which will generally be 1 inch to every 40 feet, and cover-plates and packing-strips must be fixed when necessary.

Asphalted felt is to be placed under all bearings of main girders.

9. Painting, &c.—The iron and steel work is not to be painted nor dipped in oil at the maker's works, except when the girders are put together, and then the whole of the surfaces in contact shall, before they are placed together, receive one coat of Colley's Torbay, or other approved paint. When the bridges are complete, and sufficient time has elapsed to allow the mill scale to drop off, the girders are to be well scraped, and brushed with wire brushes; and when clean and free from rust and dust, the whole of the surfaces shall receive four coats of the same paint, each coat to vary in colour, and to be left of an approved colour. Any painting damaged during the term of maintenance shall receive one additional coat or more if ordered by the engineer.

10. Hobson's Patent Flooring.—The platform plates shall be neatly fitted and rivetted into their places, and buckled where so shown on the drawings. The flooring is to be that known as Hobson's patent flooring.

11. The parapets and hand-railing shall be very neatly fitted together, felt being inserted where necessary to prevent rattling.

12. All bolts and nuts shall have a clean-cut Whitworth's thread to hold tightly, and shall be provided with washers where required. The heads of all bolts shall be formed out of the solid, and not welded on. The ends of rods and bolts shall, before securing, be swelled out so as to maintain the full sectional area of the iron at the bottom of the thread. All nuts and heads shall be of Whitworth's proportions. All bolts shall project at least one-half diameter beyond the nuts when screwed up.

13. The whole of the iron work is to be fitted together at the maker's yard, and properly marked before being taken to pieces, and when delivered on the works is to be carefully stocked, and protected from injury.

14. The contractor must provide at his own cost all necessary gantries or staging required for fixing and painting the iron work, and remove the same on completion of the contract.

15. Wherever holes are provided in floor plates, troughs, &c., for drainage they shall be fitted with tubes projecting 1 inch above the plate, in order to prevent the coating of the asphalt from running into and choking the holes.

STEEL.

16. All rolled steel must be homogeneous in character, free from surface defects, and capable of resisting a tensile strain of not less than 30 tons per square inch of section. It must show a contraction of area at the point of fracture of not less than 40 per cent. of the original area. The elongation before fracture shall be from 15 to 20 per cent. in a length of 10 inches. All steel must be annealed before leaving the maker's works. The tests for steel are to be conducted in the same manner as provided for wrought iron.

MAINTENANCE.

17. **Maintenance.**—The whole of the bridge work is to be maintained by the contractor at his own cost for twelve calendar months after the opening of the railway, in good order and condition, and to the satisfaction of the engineer, without any interruption to the traffic on the railway; and all materials, workmanship, and labour of any kind whatever, which are requisite for such maintenance of works and permanent way, are to be furnished by the contractor at his own cost; and the work is to be delivered up by the contractor, in such good order and condition, as shall be satisfactory to the engineer; and should it happen that any work of repair or renewal is in course of execution at the expiration of the said twelve months, such work is, nevertheless, to be completed by the contractor at his own cost.

LANCASHIRE AND YORKSHIRE RAILWAY COMPANY.

Specification of Ironwork.

1. **Wrought Iron.**—The plates, bars, tees, angle-irons, &c., are to be of the best quality and all of British manufacture, capable of bearing the following strains:—

That for plates lengthwise, 21 tons per square inch; contraction of area at point of fracture 8 per cent.

That for plates crosswise, 17 tons per square inch; contraction of area at point of fracture 4 per cent.

That for angle- and tee-irons, 22 tons per square inch; contraction of area at point of fracture 15 per cent.

That for flat bars, 23 tons per square inch; contraction of area at point of fracture 20 per cent.

That for round bars up to 1½ inches diameter, 21 tons per square inch; contraction of area at point of fracture 17 per cent.

That for round bars above 1½ inches diameter, 20 tons per square inch; contraction of area at point of fracture 15 per cent.

Should any of the tests be lower than 1 per cent. of the above strains they will be rejected. Each test shall be taken independently, and no average of results taken.

2. **Testing.**—All the ironwork will be subjected to such tests as the engineer may direct, at the contractor's expense; and should any parts fail or be broken in the testing, or be objected to on account of bad workmanship or materials, the contractor must replace the same at his own cost.

The engineer must be writing when any considerable quantity of iron is in the contractor's works.

3. Setting Out.—Before any setting out is done, each plate must pass through the rolls three times, the first bending to a curve, and the following ones straightening.

4. Planing, Punching, and Drilling.—All plates (and bars if used instead of plates) shall be machine-planed on all edges, and the joints in every case shall butt evenly. This also applies to flooring plates, which must butt all along their four sides to the adjacent plates. When the flange is formed of more than one plate in thickness, each plate must be planed to the same width, and finish straight with the others. All rivet-holes, except those specified to be drilled, shall be truly punched with the overlapping plates, tees, or angles; and where the holes in flanges are specified to be drilled, the whole of the plates must be put together and drilled through solid (no smaller holes having been previously punched), after which the sharp arris around each hole shall be taken off before any rivetting is commenced.

The rivet-holes in all diagonal and vertical bracings in lattice girders, and cross-bracing or tees in solid-web girders, shall be drilled and not punched; and all tee-iron stiffeners or gussets and angle irons shall be dressed-off flush with the flanges top and bottom, and each must be made to template length in order that the flanges may be quite straight and without wave in any way.

5. Rivetting.—No rivetting will be allowed until the whole girder is put together, and no drifting will be permitted. All rivets shall be of the sizes and pitch shown on the drawings, and must be upset throughout their whole length, and entirely fill all the hole.

All rivets that are not horizontal, and that are in a position admitting of it shall be upset throughout the whole length of the work. All rivet-heads shall be of the proper size, and shall be carefully snapped, both heads bedding truly on the plates, and their centres coinciding with the centre line of the rivet. Any found loose or imperfect in any way whatever must be cut out and replaced at the contractor's expense. All the wrought iron-work shall be well oiled before commencing to build the girders.

All rivets on bearings, and wherever required by the engineer, shall be countersunk, and all countersunk rivets shall have their holes cut to the proper shape to form a strong head, and in no case must the taper of the punch be taken as a sufficient spread for the head.

All bolts and nuts shall be of the best scrap iron, and shall have a strong and chased head cut upon them of uniform pitch. Heads and nuts must be hexagonal, and the nuts shall have a washer under each, and when screwed up shall have a clear thread standing through. In roof work, or where specified, all bolt holes shall be drilled true to template, and the arrises taken off, and the bolts shall be turned. All bolts and nuts, and the screwed ends of the rods, &c., shall be made to Whitworth's standard.

6. Cast-Iron Work.—The metal for the castings shall be of such a mixture of irons as is best adapted for the purpose, and shall be such that a bar 1 inch square and 4½ feet between the supports shall bear without fracture not less than 550 lbs. in the centre. The castings, when cold, must be of the pattern and dimensions shown on the drawings, and shall be cast smooth, with sharp arrises, and free from air-blows, twists, and flaws of every description. The edges of all road plates, as well as all joints and bearing areas, shall be planed to an even surface.

7. Testing Cast Iron.—The contractor shall provide for the use of the engineer, for testing purposes, bars, each 5 ft. long and 1 in. square (giving an exact sectional area of 1 in.); four shall be cast for each girder, &c., from the same metal and melting as the girders, &c., are being run.

Should any of the tests be lower than 1 per cent. of the above strains they will be rejected. Each test shall be taken independently, and no averages of results taken.

8. Columns.—All columns shall be cast vertically, and in dry sand, a head of metal being left on each casting; and for the purpose of gauging the thickness of the metal, small holes shall be drilled in the column where directed, and the thickness of metal shall be uniform in all parts of the circumference. These holes shall be afterwards filled up at the expense of the contractor.

9. Dimensions and Weights.—The whole of the iron work shall be made of the exact dimensions shown on the respective drawings; any iron work made of less dimensions than those shown on the drawings will be rejected, and any excess of weight caused by the given dimensions having been exceeded will not be paid for. Before being sent out to the works the whole must be carefully erected and fitted together in the maker's yard, and each piece numbered or lettered, so as to come together again and correspond when being permanently fixed in position.

10. Steel Rollers.—If steel rollers for expansion are used, they must be of the best quality steel, and shall be truly turned on every face, each roller being of the same diameter in order to insure a perfect bearing; care being taken that room is left at each end for the girders to expand or contract, and that the frames left in the centre of the space between the angle iron stops when the girder is brought to bear upon the rollers. Sliding plates for expansion must be planed on their faces of sliding contact.

11. Steel.—The quality of steel shall be such that the tensile strength be not less than 26 tons per square inch, with an elongation of not less than 20 per cent. in a length of 8 inches. The work when finished shall be of the best description, the steel being of Landore, Siemens Steel Company, Bolton Iron and Steel Company, West Cumberland Iron and Steel Company, Colville and Company, Motherwell, Butterley Company, or Steel Company of Scotland manufacture.

12. Painting Iron Work.—The inner surfaces of all plates, bars, &c., which are to be rivetted together, shall be well coated whilst hot with best common black paint before joining. The whole cast- and wrought-iron work shall have four coats of approved colours when completed.

The underside of all girders and road plates, where directed, shall have four coats of best common oil paint on the completion of the bridge.

The iron work shall not be painted before an examination of it has been made by or under the orders of the engineer, who must be apprised in writing when it is ready.

13. Seating to Girders.—All girders shall have seatings of the best hair felt, graduated in lengths so as to insure the pressure being on the centre of bearing when the greatest load is on the girder.

The cast-iron bed plates and columns shall have seatings of 8 lbs. lead for the full length of their bearings on masonry.

I N D E X.

- A.**
- Abutments of bridges, 52, 419.**
Admiralty (English) tests for steel,
 38.
 „ (French) „
 39.
American experiments on iron and steel struts, 211.
 „ rules for proportions of forged eyes, 389.
 „ „ for wind-pressure, 466.
Angle iron and steel struts, strength of, 209, 211, 212.
Annealing chains, 474.
 „ forgings, 34.
 „ iron wire, 34.
 „ punched plates, 395, 396.
 „ steel, 40.
Arched ribs for roofs, 352.
Arches, braced, 307, 312-318.
 „ effect of changes of temperature on, 307.
 „ „ hinging, 303-315, 353.
 „ linear, 308.
 „ rigid, 308.
 „ stresses on, 307-318.
Asphalte, weight of, 407.
Atmospheric action on galvanised sheets, 358.
Auxiliary girders in suspension bridges, 455.
- B.**
- Bars exposed to moving loads, 411.**
 „ intermittent loads on, 22.
 „ transverse strength of cast-iron, 166, 167, 168.
- Bascules, 457.**
Beams, bending moments in, 66-121.
 „ classification of, 51.
 „ continuous, 52, 61, 103.
 „ „ of uniform section, 63, 104.
 „ „ of uniform strength, 66, 107.
 „ deflection of, 13, 368.
 „ „ for moving loads, 412.
 „ fixed at the ends, 91.
 „ internal stresses in fibres of, 151.
 „ of various sections, moment of inertia of, 149.
 „ shearing stresses in, 121-136.
 „ solid, discrepancies in strength of, 162.
Bearing surfaces, 190, 416, 421.
Bending moments in beams fixed at the ends, 91.
Bending moments in beams with intermediate supports, 95.
Bending moments in cantilevers, 84-90.
 „ „ in continuous beams, 103.
 „ „ in simple beams for fixed loads, 66-84.
 „ „ in simple beams for moving loads, 110-121.
Birmingham wire gauge, 358.
Board of Trade rules for stresses in cast-iron bridges, 416.
Board of Trade rules for stresses in wrought-iron bridges, 417.
Board of Trade rules for stresses in steel bridges, 418.
Board of Trade rules for wind-pressure, 466.

- Bollman trusses, defects of, 222.
 " stresses in, 214.
 Bow's method of lettering diagrams, 237.
 Bowstring girders, relative economy of, 461.
 " " stresses in, 277.
 " " used as arches, 308.
 " " roof trusses, 340.
 Box girders, 429.
 Braced arches, 307, 312-318.
 " girders, 214.
 " semi-arches, 315.
 Braces, 214.
 Bracing, wind, for roofs, 352.
 Brickwork, weight of, 10, 407.
 Bridges, cantilever, 403.
 " cast-iron, 425.
 " " working stresses on, 415.
 " different kinds of, 402.
 " dimensions of, 405.
 " erection of, 478.
 " exposed to loads in rapid motion, 411.
 " floors of (iron and steel), 435.
 " " (timber), 434.
 " lifting, 459.
 " loads on, 405.
 " longitudinal stresses in, 414.
 " movable, 456.
 " particulars required for designing, 403.
 " platforms of, 430.
 " pontoon, 459.
 " public road, loads on, 407.
 " rail-bearers of, 433.
 " railway, loads on, 408.
 " side stresses on, 413.
 " steel, working stresses on, 418.
 " stresses on, from centrifugal force, 413.
 " suspension, 443.
 " swing, 457.
 " traversing, 459.
 " weight of, 459.
 " wrought-iron and steel, 426.
 " wrought-iron and steel, working stresses on, 417.
 Buckled plates, 437-439.
- C.
- Cables of suspension bridges, 451, 453.
 Caissons, 420.
 Camber in girders, 370.
 Cantilevers, 52.
 " bending moments in, 84.
 " shearing stresses in, 127.
 Castings, American, superior strength of, 31.
 " chilled, superior strength of, 29.
 " relative strength of small and large, 23.
 " steel, 39.
 Cast-iron girders, proportions of, 425.
 " " strength of, 29, 30, 483, 487.
 " flooring plates, 435.
 " unreliable nature of, 27.
 " varieties of, 27.
 " working stresses on, 196, 416.
 Catenary curve, 443.
 Centre of gravity of plane surfaces, 136.
 " practical method of finding, 139.
 Centrifugal force, 413.
 Chains, close-link and studded-link, 473.
 " fatigue of, 473.
 " ultimate strength, proof stress, and working stress of, 474.
 " weight of, 475.
 Clay, weight of, 10.
 Coefficient of expansion for increase of temperature, 36.
 Cofferdams, 420.
 Columns, cast-iron, 188-204.
 " casting of, 197.
 " Gordon's rules for strength of, 198, 202, 203, 212.
 " Hodgkinson's rules for, 190, 202.
 " long, 183, 189, 190.
 " of medium length, 188.
 " of + and H-section, 198.
 " proportions of cast-iron, 196.

- Columns, Rankine's rules for, 203-206.
 „ safe working load on, 196.
 „ short, 188.
 „ steel, 212-214.
 „ with rounded and flat ends, 189.
 „ wrought-iron, 204-211.
 Compound girders of iron and steel, 427.
 Concrete, weight of, 407.
 Continuous girders, ambiguity of stresses in, 62.
 „ „ points of inflexion in, 104.
 „ „ relative economy of, 462.
 Corrosion in iron and steel, 357, 428, 456.
 Corrugated iron covering for roofs, 356.
 „ „ flooring for bridges, 439.
 Cotters, 390-392.
 Counterbracing lattice girders, 276.
 Covers for joints in girders, 386.
 Cranes, derrick, 299, 470.
 „ jib, 291.
 „ lattice, 305.
 „ Scotch, 299, 471.
 „ wharf, 304.
 „ with rolling loads, 301.
 Cross-girders, 417, 432.
 „ weight of, 433.
 Crushing strength of steel, 37.
 Curved road plates, 435.
 „ roof trusses, 339.
 Cylinders for piers, 423.
- D.**
- Deflection** of beams and girders, 13, 365.
 Deflection of beams and girders, a means of determining the modulus of elasticity, 12.
 Deflection of beams and girders, amount of, not affected by kind of web, 366.
 Depth of girders, 426, 427.
- Derrick crane, 299, 470.
 Desiccating process for seasoning timber, 26.
 Diagrams of bending moments, 69-74, 80-82, 85-99, 106, 115.
 „ shearing stresses, 121-135.
 „ stress for Bollman truss, 218.
 „ „ braced arches, 313, 316, 317.
 „ „ braced girders with curved flanges, 278, 284, 288, 289.
 „ „ Linvilletrusses, 264, 273.
 „ „ roof trusses, 322, 324, 325, 327, 329-343.
 „ „ suspension bridges, 444, 448, 450.
 „ „ Warren girders, 234, 238, 244, 248, 250, 251, 256.
 Dredge's system of suspension bridges, 448.
 Drilling iron and steel plates, 395.
 „ weakening effect of, 393.
 Driving piles, 420.
 Dynamic effect of loads on beams, 411-415.
- E.**
- Earth**, weight of, 10.
 Economy (relative) of bridges of different designs, 462.
 Elasticity, a measure of strength, 12, 18.
 „ Hooke's law of, 12.
 „ limits of, 11.
 „ modulus of, E, 12.
 „ of steel, 38.
 Engines (railway), weight of, 408.
 Equilibrium, 44.
 „ curve of, in rigid arches, 308.
 „ of three forces, 45.

Erection of bridges, 476.
 " " by building out, 480.
 " " by floating 478.
 " " by rolling over, 479.
 " " upon staging, 478.
 Erection of buildings, 481.
 " cost of, 481.
 Expansion due to increase of temperature, 35, 307.
 Experiments by Wöhler, 23.
 " on eye-bars, 388, 390.
 " on iron bars, 22, 166.
 " on punching and drilling plates, 393-396.
 " on the strength of rivets, 401.
 " on wrought-iron columns, 208.
 " on wrought-iron plates and bars, 32, 35.
 " on wrought-iron struts (Christie), 211, 212.
 External loads on structures, 1, 52, 292.
 Eye-bars, best proportions of, 388.
 " rules of American engineers, 389.

F.

Factor of safety, 16, 17, 415.
 " " for cast-iron columns, 196.
 Fatigue of chains, 473.
 " materials, 21.
 Felt covering for roofs, 362.
 Fink truss, 225-233.
 Fish-bellied girders, 286.
 Flanges of girders, 426.
 Flooring, iron, of bridges, 435.
 " Lindsay's patent, 439-443.
 " timber, for bridges, 434.
 " trough and corrugated, 439-443, 485.
 Floors of buildings, loads on, 182.
 Forces, compressive and tensile, 43.
 " mechanical, 42.
 " resolution of, 47.
 " supporting, of beams, 52-61.

Forces, supporting, of continuous beams, 61-66.
 Forth bridge, stresses on, 463.
 Foundations, timber, 419.
 French rules for strength of steel, 39.
 " for working stresses on cast-iron, 416.
 " for working stresses on wrought-iron railway bridges, 418.

G.

Galvanising iron sheets for roofs, 357.
 Girders, auxiliary, for suspension bridges, 455.
 " bowstring, 277, 340, 461.
 " box, 429.
 " camber of, 370.
 " cantilever, 52, 84-103, 127-130.
 " continuous, 52, 61-66, 103-110, 462.
 " cross, of bridges, 417, 432, 433.
 " curved, 277.
 " deflection of, 13, 368, 412.
 " depth of, 426.
 " lattice, 258.
 " Linville, 262-276.
 " of different materials in combination, 427.
 " of uniform section, 65, 91, 105.
 " " strength, 66, 107.
 " plate-web, 427.
 " rolled, 180-186, 429.
 " tubular, 430.
 " Warren, 233-258.
 " weight of, 459.
 Glass covering for roofs, 362.
 Gordon's rules for the strength of columns, 198, 202, 205, 212.
 Government rules. See "Board of Trade."
 Granite, weight of, 9, 407.
 Graphic system as applied to structures, 45.
 Gravity, centre of, 136.
 Gyration, radius of, 203-209.

H.

- Heat, effect of. See "Expansion."
 Hemp ropes, 471.
 Hinges in arched ribs, 308-315, 353.
 " in auxiliary girders, 454.
 Hodgkinson's rules for the strength of columns, 190, 202.
 Hooke's law of elasticity, 12.
 Hydraulic pressure applied to steel, 40.
 " rivetters, 399.

I.

- Impact, effects of, 21-24.
 Inertia, moment of, 140.
 " " table of, for beams of different sections, 149-151.
 Inflexion, points of, 103.
 Intermediate bearers of bridges, 433.
 Iron, cast, as used in structures, 27.
 " " strength of, 28-31.
 " " corrosion of, 357, 428, 456.
 " wire, 34.
 " wrought, as used in structures, 31.
 " " strength of, 32-35.
 " " testing, 31.

J.

- Jib cranes, 291.
 Joints, butt, 382.
 " by cotters, 390.
 " by pins, 387.
 " in flanges of girders, 335.
 " lap, 377.
 " proportions of, 379.
 " relative economy of, 381.
 Joists, rolled, 180, 429.

K.

- Kennedy's experiments on perforated plates, 396.
 King-posts in timber roof, 364.

L.

- Lap-joints, strength of, 377.
 Lateral adhesion of fibres, theory of, 164.
 Lattice crane, 305.
 " girders, camber in, 373.
 " " different types of, 258.
 Lead-covering for roofs, 362.
 Lever, principle of, 44.
 Lifting-bridges, 459.
 Limestone, weight of, 9, 407.
 Lindsay's steel flooring, 439-443.
 Linear arches, 308.
 Line of pressures in arches, 308.
 Links of suspension bridges, 387, 451.
 Linville truss, 262-276.
 Lloyd's tests for steel ship-plates, 39.
 Loads, concentrated, 53.
 " dead, 17, 346, 407.
 " external, on structures, 1, 52, 292.
 " intermittent, 17, 22, 23.
 " live, 17, 346, 407, 408.
 " moving, travelling, or rolling, 110.
 " on floors of buildings, 182.
 " on railway bridges, 408-412.
 " on road bridges, 404-408.
 " on roofs, 346-349.
 " uniformly distributed, 53.

M.

- Macadam, weight of, 407.
 Materials used in structures, 25.
 Measurement of stresses and strains, 3.
 Mechanical laws relating to stresses, 41.
 Modulus of elasticity, E, 12.
 " " methods of determining, 12.
 " " table of, for different materials, 14.
 " of resilience, 20.
 " of rupture, *f*, 164.
 Moment, bending, M. See "Bending moment."

Moment of inertia, 140-151.
 ,, of resistance, 153.
 ,, ,, for different beams, 154-162.
 Moments, principle of, 43.
 Mortar, weight of, 10.
 Movable bridges, different kinds of, 456-459.

N.

Neutral axis in beams, 153.
 ,, surface in beams, 152.

O.

Oak, strength of, 26.
 ,, weight of, 9, 407.
 Oscillations in suspension bridges, 454.
 Over bridges, dimensions of, 405.

P.

Painting iron and steel structures, 358, 361, 430, 456, 483, 485, 488.
 Panels of lattice girders, 233.
 Parabolic curve, 443.
 Parallelogram of forces, 45.
 Parker's experiments on punched and drilled plates, 395.
 Perforated plates, increased strength of, 396.
 Perforating plates, different methods of, 392.
 Piers, braced, stresses on, 467.
 ,, iron, 421-424.
 ,, masonry, 421.
 ,, of cast-iron cylinders, 423.
 ,, of screw piles, 423.
 Piles, screw, 421-423.
 ,, timber, 419.
 Pillars. See "Columns" and "Struts."
 Pine, weight of, 9, 407.
 Pins in single and double shear, 4.
 ,, shearing strength of, 388.
 Plate-girders, different forms of, 427.
 Plates, strength of, both *with* and *across* the fibre, 32, 33.

Platforms of bridges, 430.
 ,, of railway bridges, weight of, 431.
 Pneumatic riveters, 400.
 Points of inflexion or contrary flexure. See "Inflexion."
 Pressure of wind, 463-469.
 ,, required to form rivet-heads, 400.
 Principals of roofs. See "Roof-trusses"
 Proof loads and stresses, 18.
 ,, on chains, 474.
 Public road bridges, dimensions of, 405.
 ,, loads on, 407.
 Punches and dies, relative sizes of, 393.
 Punching iron plates, 393.
 ,, steel plates, 395.
 ,, weakening effect of, 393.

Q.

Queen-posts in timber roofs, 364, 365.

R.

Radius of gyration in struts, 203-209.
 Rafters, 349, 352.
 Rail-bearers of bridges, 432, 433.
 Railway bridges, dimensions relating to, 405, 406.
 ,, loads on, 408-412.
 ,, longitudinal stresses on, 414.
 ,, long span, relative economy of, 461-463.
 ,, under 200 feet span, weight of, 461.
 ,, weight of platforms of, 431.
 ,, working stresses on, 415-419.
 Rankine's formulæ for columns and long struts, 203-206.
 Resilience of bars, 19.
 ,, modulus of, 20.

Resistance, moment of, 153.
 Resolution of forces, 47.
 Rigid arches, 308.
 Rigidity in suspension bridges, 453, 454.
 Ritter's method of moments, 279.
 Rivet-heads, different forms of, 396.
 " methods of forming, 398-401.
 " pressure necessary for forming, 400.
 Rivets in single and double shear, 375, 376.
 " iron, working stresses on, 376.
 " relative strength of, in drilled and punched holes, 396.
 " shearing strength of, 376.
 " steel, working stresses on, 377.
 " strength of, put in by different machines, 401.
 Rivetted joints, strength of, 374-386.
 Rivetters, hydraulic, 399.
 " mechanical, 399.
 " pneumatic, 400.
 " steam, 399.
 Rivetting by hand, 399.
 " cost of, 399, 401.
 " Road-bearers in bridges, 432.
 Road bridges, loads on, 407, 408.
 " public, widths of, 405.
 Rolled girders, 180-186, 429.
 " approximate strength of, 184.
 " strength of, 180-184.
 " table of strengths, 186.
 Rolling loads, 111.
 Roof coverings, 354.
 Roofs, loads on, 346-349.
 " timber, 363-365.
 " weight of snow on, 347.
 " wind-bracing for, 352.
 " wind-pressure on, 347.
 " working stresses on, 354.
 Roof trusses, 319-354.
 " cantilever, 329.
 " French, 335.
 " saw-tooth, 337.
 Ropes, preserving, 473.
 " strength of, 471, 472.

S.

Safety, factor of. See "Factor."
 Sand, weight of, 10, 407.
 Sandstone, weight of, 9, 407.
 Screw-piles, 421-423.
 " methods of sinking, 422.
 Seasoning timber, 26.
 Semi-arch, braced, 315.
 " beams and semi-girders. See "Cantilevers."
 Set, temporary and permanent, 16.
 Shaler Smith's experiments on eye-bars, 390.
 Shear, single and double, 4, 375.
 Shearing experiments, 35.
 " forces in beams for fixed loads, 121-130.
 " forces in beams for moving loads, 130-136.
 " strength of cotters, 392.
 " pins, 388.
 " rivets, 376.
 " steel, 37.
 " wrought iron, 35.
 " stresses in webs of plate-girders, 418, 427-430.
 Sheer-legs, 300, 471.
 Shoes of principals, 351.
 Side pressure on bridges, 413.
 Slates for roofs, 355.
 Snow, weight of, 347.
 Steel, Admiralty tests for, 38, 39.
 " advantages of, for bridge work, 37.
 " annealing, 40.
 " Board of Trade rules for, 418.
 " buckled plates, strength of, 439.
 " castings, 39.
 " columns and struts, 212-214.
 " crushing strength of, 37.
 " elasticity of, 38.
 " flooring plates, 435, 439-443.
 " Lloyd's rules for ship-plates, 39.
 " rivets, strength of, 377.
 " rolled joists, strength of, 186.
 " shearing strength of, 37.
 " tensile strength of, 37-41, 486.
 " treatment of, by hydraulic pressure, 40.

- Steel troughs for bridge floors, 439-443.
 ,, wire, strength of, 453.
 ,, working stresses in, 418.
 Stiffeners to webs of plate-girders, 428.
 Stiffening suspension bridges, 454.
 Strains, different kinds of, 2-5.
 Stresses, different kinds of, 2-5.
 ,, internal, in beams, theory of, 151.
 ,, measurement of, 3.
 ,, on braced piers, 467.
 ,, working, in cast-iron, 196, 416.
 ,, ,, in chains, 474.
 ,, ,, in steel, 418.
 ,, ,, in timber, 419.
 ,, ,, in wrought-iron, 417, 418.
 Struts, long, 7. See also "Columns."
 Suspension bridges, advantages and disadvantages of, 453.
 ,, ,, attachment of chains to piers, 446.
 ,, ,, stiffening, 454.
 ,, ,, stress-diagrams of, 444, 450.
 ,, ,, suspending-rods of, stresses on, 448.
 ,, ,, with sloping suspension-rods, 448.
- T.**
- Tay bridge, 414, 463.
 Tee struts, strength of, 209-212.
 Temperature, effects of. See "Expansion."
 Tensile strength of cast iron, 29, 30.
 ,, ,, steel, 37-41.
 ,, ,, timber, 26.
 ,, ,, welds, 34.
 ,, ,, wire, 34, 453.
 ,, ,, wrought iron, 32.
 Testing wrought iron, 31.
 Tie bars, main, of roof trusses, 350.
 Tiles for roofs, 356.
- Timber flooring for bridges, 434.
 ,, foundations, 419.
 ,, roofs, 363-365.
 ,, seasoning, 26.
 ,, strength of, 25, 26.
 ,, working stresses on, 419.
 Torsional stresses, 5.
 Trapezoidal truss, 222-224.
 Traversing bridges, 459.
 Triangle of forces, 47.
 Tripods, 301, 471.
 Trough flooring for bridges, 439.
 Truss, Bollman, 214-222.
 ,, Fink, 225-233.
 ,, Linville, 262-276.
 ,, roof, 319-354.
 ,, trapezoidal, 222-224.
 Tubular bridges, 430.
 ,, ,, Britannia, erection of, 478, 479.
- U.**
- Ultimate strength, 16.
 Under bridges, dimensions of, 405.
 Unit-stress, 3.
- V.**
- Variations in the strength of timber, 25.
 Velocity and pressure of wind, relationship between, 464.
 Ventilation of buildings, 363.
 Vibrations, effects of, on materials and structures, 22, 40, 196, 415-418.
- W.**
- Warren girders, stresses in, 233-255.
 ,, ,, with vertical bracings, stresses in, 255-258.
 Webs of plate girders, 427.
 ,, ,, shearing stresses in, 418.
 Weight of bridges, 459, 461.
 ,, chains, 475.
 ,, corrugated iron, 358.
 ,, cross-girders, 433.

- Weight of crowd of people, 407.
 „ different materials, table of, 8-10.
 „ flooring on railway bridges, 431.
 „ girders under 200 feet span, 460.
 „ Lindsay's patent troughs, 441.
 „ long span railway bridges, relative, 461.
 „ rail girders, 433.
 „ railway locomotives, 409.
 „ road metalling for bridges, 407.
 „ rolled girders, table of, 186.
 „ roof coverings, 355.
 „ roof principals, 347.
 „ ropes, 475.
 „ snow, 347.
 „ zinc sheets for roof covering, 361.
 Welds, strength of, 34.
 Wharf crane, 304.
 Whitworth's, Sir J., method of compressing fluid steel, 40.
 Wind-bracing for bridges, 467.
 „ „ roofs, 352.
 „ pressure and velocity, 463-467.
 „ „ Board of Trade rules for, 466.
 „ „ circumstance which influence, 463.
 „ „ influenced by the form of surface, 467.
 „ „ on lattice girders, 466.
 „ „ on swing-bridges, 458, 459.
 „ „ on the Forth Bridge, 463.
 „ „ rules of American engineers on, 466.
 Wire cables for suspension bridges, 451, 453.
 Wire gauge, Birmingham, 358.
 „ iron, annealing, 34.
 „ „ strength of, 34, 453.
 „ „ steel, strength of, 453.
 Wöhler's experiments on the fatigue of materials, 23, 24.
 Wood. See "Timber."
 Work done in stretching a bar, 19.
 Working stresses on cast iron, 196, 416.
 „ „ chains, 474.
 „ „ steel, 418.
 „ „ timber, 419.
 „ „ wrought iron, 417.
 Wrought iron, annealing, 34, 395, 396, 474.
 „ Board of Trade rules for stresses on, 417.
 „ buckled plates, strength of, 439.
 „ columns and struts, 204-211.
 „ compressive strength of, 34.
 „ flooring plates, 435-437.
 „ shearing strength of, 35.
 „ tensile strength of, 32.
 „ tensile strength of, across the fibre, 33.
 „ tensile strength of, as used in bridge work, 33, 484, 486.
 „ testing, 31.
 Z
 Zinc covering for roofs, 360-362.
 „ gauge for sheets, 361.

A SELECTION
FROM
CHARLES GRIFFIN AND COMPANY'S
LIST OF PUBLICATIONS.

*New Ready, Medium 8vo, Cloth. With 48 Lithographic Plates and
Numerous Woodcuts, 25s.*

HYDRAULIC POWER AND HYDRAULIC MACHINERY,

FOR THE USE OF

PRACTICAL ENGINEERS AND STUDENTS.

By HENRY ROBINSON, M. INST. C.E., F.G.S., &c.,
Prof. of Civil Engineering, King's College, London.

GENERAL CONTENTS.

The Flow of Water under Pressure—General Observations—Waterwheels—Turbines—Centrifugal Pumps—Water-Pressure Pumps—The Accumulator—Hydraulic Pumping Engine—Three-Cylinder Engines and Capstans—Motors with Variable Power—Hydraulic Presses and Lifts—Moveable Jigger Hoist—Hydraulic Waggon Drop—The Flow of Solids—Shop Tools—Cranes—Hydraulic Power applied to Bridges—Dock-Gate Machinery—Hydraulic Coal-discharging Machines—Hydraulic Machinery on board Ship—Hydraulic Pile Driver—Hydraulic Excavator—Hydraulic Drill—Hydraulic Brake—Hydraulic Gun-Carriages—Jets—Hydraulic Ram—Packing—Power Co-operation—Cost of Hydraulic Power—Tapping Pressure Mains—Meters—Waste Water Meter—Pressure Reducing Valves—Pressure Regulator.

LIST OF PLATES.

Davey's Water-Pressure Pumping Engine—Brown's Steam Accumulator—Tweedell's Accumulator—Elswick High-Pressure Pumping Engine—Compound Hydraulic Engine—The "Worthington" Pumping Engine—Brotherhood's Three-Cylinder Hydraulic Engine—Turnover Hydraulic Capstan—Double-Powered Hydraulic Crane—Haastie's Low-Pressure Hoist—Details of Low-Pressure Hoist—La Louvière Press—La Louvière Lift—Mersey Railway Lifts—Hydraulic Balance Lift—The "Otis" Elevator—Moveable Jigger Hoist—Table of Results of Rivetting Tests—Hydraulic Chain-Cable Shears—5-Ton Angle Iron Bending Machine—Hydraulic Flanging Machine—12 Ton Hydraulic Centre Crane—Hydraulic Crane for Goods Shed—Hydraulic Station Crane—Moveable Hydraulic Crane—160-Ton Arsenal Crane—Hydraulic Swing Bridge—Ouse Swing Bridge, Section of Centre Pier—Ouse Swing Bridge, Half Section of Engine Room—Ouse Swing Bridge, Locking Gear at Ends of Bridge—Elswick Gate Crab—Hydraulic Capstan and Gate Opening and Closing Machinery for 60-Foot Lock—Hydraulic Machine for Opening and Closing 80-Foot Lock Gates—Elswick Direct-Acting Hydraulic Sluice Machine—Coal-Whipping Machine—Moveable Hydraulic Crane—Hydraulic Steering Gear—Hydraulic Reversing Gear—Hydraulic Excavator—The Brandt Drill, Elevation—The Brandt Drill, Section—Langley's Hydraulic Buffer Stop—Greathead's Injector Hydrant.

EXETER STREET, STRAND, LONDON.

CHARLES GRIFFIN & COMPANY,

SECOND EDITION. *In Royal 8vo. with Numerous Illustrations, 26s.*

ELEMENTS OF METALLURGY:

A PRACTICAL TREATISE ON THE ART OF EXTRACTING METALS FROM THEIR ORES.

By J. ARTHUR PHILLIPS, C.E., F.C.S., F.G.S.,

Ancien Elève de l'Ecole des Mines, Paris.

Re-Written and Edited by the Author, and by H. Bauerman, F.G.S.

GENERAL CONTENTS.

I. A TREATISE ON FUELS and REFRACTORY MATERIALS.

II. A DESCRIPTION of the principal METALLIFEROUS MINERALS with their DISTRIBUTION.

III. STATISTICS of the amount of each METAL annually produced throughout the world, obtained from official sources, or, where this has not been practicable, from authentic private information.

IV. The METHODS of ASSAYING the different ORES, together with the PROCESSES of METALLURGICAL TREATMENT, comprising: IRON, COBALT, NICKEL, ALUMINIUM, COPPER, TIN, ANTIMONY, ARSENIC, ZINC, MERCURY, BISMUTH, LEAD, SILVER, GOLD, and PLATINUM.

"The value of this work is almost inestimable."—*Mining Journal.*

In Two Parts, Demy 8vo.

A MANUAL OF GEOLOGY,

By JOHN PHILLIPS, M.A., LL.D., F.R.S.,

Late Prof. of Geology in the University of Oxford.

RE-WRITTEN AND EDITED BY ROBERT ETHERIDGE, F.R.S.,

Of the Natural History Department, British Museum, late Palaeontologist to the Geological Survey of Great Britain, Past-President of the Geological Society; and

HARRY GOVIER SEELEY, F.R.S.,

Professor of Geography in King's College, London.

Part I.—PHYSICAL GEOLOGY AND PALAEONTOLOGY. By Professor SEELEY. 18s.

Part II.—STRATIGRAPHICAL GEOLOGY AND PALAEONTOLOGY. By R. ETHERIDGE, F.R.S. 34s.

With Numerous Tables, Sections, and Figures of Characteristic Fossils.

PUBLISHED WITH CONCURRENCE OF THE SURVEYORS-GENERAL OF NEW SOUTH WALES AND VICTORIA.

SECOND EDITION. *Half-Bound, Folio, Price 51s.*

TRAVERSE TABLES:

Computed to 4 Places Decimals for every Minute of Angle up to 100 of Distance.

For the Use of Surveyors and Engineers.

By R. LLOYD GURDEN,

Authorized Surveyor for the Governments of New South Wales and Victoria.

EXETER STREET, STRAND, LONDON.

CHARLES GRIFFIN AND COMPANY,

Medium 8vo, Handsome cloth, 30s.

BRIDGE-CONSTRUCTION

(A PRACTICAL TREATISE ON):

Being a Text-Book on the Design and Construction of
Bridges in Iron and Steel.

FOR THE USE OF STUDENTS, DRAUGHTSMEN, AND ENGINEERS.

BY

T. CLAXTON FIDLER, M. INST. C.E

With Numerous Woodcuts and 17 Lithographic Plates.

THE object of this book is to describe the modern practice of Bridge-Construction, and to set forth in the simplest language the mechanical principles and experimental facts on which it is based. The design and arrangement of the work have been dictated by a desire to render it as useful as possible, not only to Engineers or Draughtsmen who may be engaged in the work of Bridge-Calculations and Bridge-Construction, but also to Students. With this object, the earlier chapters of the work are devoted to a simple demonstration of those mechanical principles which must of necessity form the beginning of any study of the subject, and which are more fully developed and applied in later portions of the book.

"Should prove not only an **INDISPENSABLE** Hand-book for the Practical Engineer, but also a stimulating Treatise to the Student of Mathematical Mechanics and Elasticity."—*Nature*.

"One of the **VERY BEST RECENT** works on the Strength of Materials and its application to Bridge-Construction. . . . Well repays a careful study."—*Engineering*.

"As an exposition of the **LATEST** advances of the Science, we are glad to welcome this well-written Treatise."—*Architect*.

"A Scientific Treatise of great merit, which cannot but prove useful."—*Westminster Review*.

"Mr. Fidler's book is one which every Student of Mechanics ought to possess, and which merits, as it will receive, the appreciative attention of all practical men."—*Scoteman*.

A full Prospectus of the above important work may be had on application to the Publishers.

EXETER STREET, STRAND, LONDON.

INDEX TO AUTHORS.

	PAGE		PAGE
AITKEN (Sir W., M.D.), Science and Practice of Medicine,	9	JAMES (W. P.), From Source to Sea,	53
— Outlines,	9	JAMIESON (A.), Manual of the Steam Engine	39
ANDERSON (M'Call) on Skin Diseases,	14	— Steam and the Steam Engine—Elementary,	39
ANGLIN (S.), Design of Structures,	21	— Applied Mechanics,	33
BELL (R.), Golden Leaves,	58	— Magnetism and Electricity,	33
BERINGER (J. J. and C.), Assaying,	22	JEVONS (F. B.), A History of Greek Literature,	54
BLYTH (A. W.), Hygiene and Public Health,	10	— Athenian Democracy,	54
— Foods and Poisons,	10	KEHLES' Christian Year,	4
BROTHERS (A.), Photography,	22	LANDIS (Dr.), Management of Labour,	18
BROUGH (B. H.), Mine-Surveying,	23	LANDOIS and STIRLING'S Physiology,	13
BROWNE (W. R.), Student's Mechanics,	23	LEWIS (W. B.), Mental Diseases,	15
— Foundations of Mechanics,	23	LINN (Dr.), On the Teeth,	18
— Fuel and Water,	23	LONGMORE (Prof.), Sanitary Contrasts,	19
BRUCE (A. H.) Works of Virgil,	50	MACALISTER (Prof.), Human Anatomy,	62
RUNYAN'S Pilgrim's Progress (Mason),	4	MACKEY (A. G.), Lexicon of Freemasonry,	61
BURNET (Dr.), Foods and Dietaries,	11	MAYHEW (Dr.), London Labour,	61
CAIRD and CATHCART, Surgical Handbook,	12	M'BURNEY (Dr.), Ovid's Metamorphoses,	55
CHEEVERS (Dr.), Religious Anecdotes,	4	MEYER and FERGUS' Ophthalmology,	14
COBBETT (Wm.), Advice to Young Men,	58	MILLER (W. G.), Philosophy of Law,	55
— Cottage Economy,	58	M'MILLAN (W. G.), Electro-Metallurgy,	34
— English Grammar,	50	MUNRO (R. D.), Steam Boilers,	33
— French do.,	50	MUNRO and JAMIESON'S Electrical Pocket-Book,	35
— Legacy to Labourers,	59	NYSTROM'S Pocket-Book for Engineers,	35
— Do. Parsons,	59	OBERSTEINER and HILL, Central Nervous Organs,	15
COBRIN'S Mangnall's Questions,	50	PAGE (H.W.), Railway Injuries,	15
COLE (Prof.), Practical Geology,	24	PARKER (Prof.), Mammalian Descent,	19
COLERIDGE on Method,	50	PHILLIPS and BAUERMAN, Metallurgy,	38
CRAIK (G.), History of English Literature,	51	POE (Edgar), Poetical Works of,	60
— Manual of do.,	51	PORTER (Surg.-Maj.), Surgeon's Pocket-Book,	19
CRIMP (W. S.), Sewage Disposal Works,	25	RAMSAY (Prof.), Roman Antiquities,	55
CROOM (Halliday), Gynecology,	16	— Do. Elementary,	55
CRUDEN'S CONCORDANCE, by Eadie,	6	— Latin Proseody,	55
CRUTWELL'S History of Roman Literature,	53	— Do. Elementary,	55
— Specimens of do.,	53	RANKINE'S ENGINEERING WORKS,	39, 40
— Early Christian Literature,	4	REED (Sir E. J.), Stability of Ships,	41
CURRIE (J.), Works of Horace,	50	ROBERTS-AUSTEN (Prof.), Metallurgy,	43
DAVIS (J. R. A.), An Introduction to Biology,	26	ROBINSON (Prof.), Hydraulics,	43
— The Flowering Plant,	26	SANSOM (A. E.), Diseases of the Heart,	16
— Zoological Pocket-Book,	27	SCHRADER and JEVONS, The Prehistoric Antiquities of the Aryan Peoples,	56
DICK (Dr.), Celestial Scenery,	4	SCHWACKHÖFER and BROWNE, Fuel and Water,	44
DOERING and GRÈME'S Hellas,	53	SEATON (A. E.), Marine Engineering,	43
DORSEY (A. J.), Spelling by Dictation,	53	SEELEY (Prof.), Physical Geology,	36
DUCKWORTH (Sir D., M.D.), Gout,	14	SENIOR (Prof.), Political Economy,	57
DUPRÉ & HAKE, Manual of Chemistry,	27	SEXTON (Prof.), Quantitative Analysis,	44
EADIE (Rev. Dr.), Biblical Cyclopædia,	6	— Qualitative Analysis,	44
— Cruden's Concordance,	6	SHELTON-BEY (W. V.), Mechanic's Guide,	44
— Classified Bible,	6	SOUTHGATE (H.), Many Thoughts of Many Minds,	64
— Ecclesiastical Cyclopædia,	6	— Suggestive Thoughts,	7
— Dictionary of the Bible,	6	— (Mrs.), Christian Life,	7
ELBORNE (W.), Pharmacy and Materia Medica,	12	STIRLING (William), Human Physiology,	13
EMERALD SERIES OF POETS,	60	— Outlines of Practical Physiology,	20
ETHERIDGE (R.), Stratigraphical Geology,	37	— Outlines of Practical Histology,	20
EWART (Prof.), The Preservation of Fish,	27	TAIT (Rev. J.), Mind in Matter,	8
FIDLER (T. Claxton), Bridge-Construction,	28	THE MASSES: How shall we reach them? ,	8
FLEMING (Prof.), Vocabulary of Philosophy,	53	THOMSON (Dr. Spencer), Domestic Medicine,	63
FOSTER (Chas.), Story of the Bible,	5	THOMSON'S Seasons,	57
FOSTER (C. Le N.), Ore and Stone Mining,	29	THORBURN (Wm), Surgery of the Spine,	15
GARROD (Dr. A. E.), Rheumatism,	14	THORNTON (J. K.), Surgery of the Kidneys,	15
GILMER (R.), Interest Tables,	50	TRAILL (W.), Boilers, Land and Marine,	46
GRÈME (Elliott), Beethoven,	50	WHATELY (Archbishop), Logic and Rhetoric,	57
— Novel with Two Heres,	59	WORDS and WORKS OF OUR LORD,	8
GRIFFIN (J. J.), Chemical Recreations,	29	WRIGHT (Alder), The Threshold of Science,	47
GURDEN (R.), Traverse Tables,	29	YEAR-BOOK OF SCIENTIFIC SOCIETIES,	46
HADDON (Prof.), Embryology,	13		
HUGHES (H. W.), Coal-Mining,	29		
HUMPHRY, Manual of Nursing,	18		
JAKSCH (v.) and CAGNEY, Clinical Diagnosis,	14		

INDEX TO SUBJECTS.

	PAGE		PAGE
ANATOMY, Human,	13	LITERATURE, English,	51
ANECDOTES, (Cyclopædia of,	4	—Greek,	54
ANTIQUITIES, Prehistoric, .	50	—Roman,	52
—Greek,	54	LOGIC,	57
—Roman,	55	MACHINERY, Hydraulic, . . .	43
ARYAN PEOPLES,	56	—and Millwork,	39
ASSAVING,	22	MAGNETISM,	32, 33
BIBLE (The Holy), Classified, .	6	MAMMALIAN Descent,	19
—Concordance to,	6	MARINE Engineering,	45
—Cyclopædia of,	6	MECHANICS,	23, 3, 35, 36, 40, 44
—Dictionary of,	6	MEDICAL Series,	13-16
—Story of,	5	—Works,	9
BIOLOGY,	26	MEDICINE, Science and Practicc of,	9
BOILERS, Marine and Land, . . .	46	—Domestic,	63
—Management of,	33	MENTAL Diseases,	15
BOTANY,	26	—Science,	55
BRAIN, The,	15	METALLURGY,	38, 42
BRIDGE CONSTRUCTION,	21, 28	MINE-SURVEYING,	23
CHEMISTRY, Inorganic,	27	MINING, Coal,	29
—Experiments in,	47	—Ore and Stone,	29
—Qualitative Analysis,	44	MYTHOLOGY, Greek,	53
—Quantitative,	44	NAVAL Construction,	41
—Recreations in,	29	NERVOUS ORGANS, Central, . . .	15
CLINICAL Diagnosis,	14	NURSING, Medical and Surgical, .	18, 61
DAILY Readings,	7, 8	OBSTETRICS,	18
DICTIONARY of Anecdotes,	4	PALÆONTOLOGY,	24, 36, 37
—of the Holy Bible,	6	PHARMACY,	12
—Ecclesiastical,	6	PHILOSOPHY, Vocabulary of, . . .	53
—of Medicine (Domestic),	63	PHOTOGRAPHY,	22
—of Philosophical Terms,	53	PHYSICS, Experiments in,	47
—of Quotations,	64	PHYSIOLOGY, Human,	13
—of (Religious),	7	—Practical,	27
DIETARIES for the Sick,	11	POCKET-BOOK, Electrical,	35
EDUCATIONAL Works,	49	—Engineering,	35
ELECTRICITY,	32, 33, 35	—Surgical,	12, 19
ELECTRO-METALLURGY,	33-4	—Zoological,	27
EMBRYOLOGY,	13, 19	POETS, Emerald Series of,	60
ENGINEERING, Civil,	39	POISONS, Detection of,	10
—Marine,	45	POLITICAL ECONOMY,	57
—Useful Rules in,	35, 40	POOR, Condition of the,	8, 61
EYE, Diseases of the,	14	RAILWAY Injuries,	15
FISH, Preservation of,	27	RELIGIOUS Works,	4
FOODS, Analysis of,	10	RHETORIC,	57
FOODS and Dietaries,	11	RHEUMATISM,	14
FREEMASONRY,	61	ROOFS, Design of,	21
FUEL and Water,	44	SCIENCE, Popular Introduction to, .	47
GEOLOGY, Practical,	24	SCIENTIFIC Societies, Papers read before, .	48
—Physical,	36	SEWAGE Disposal Works,	25
—Stratigraphical,	37	SHIPS, Stability of,	41
GOUT,	14	—Wave-forms, Propulsion, &c. (Rankine), .	40
GRAMMARS,	50	SKIN, Diseases of the,	14
GYNÆCOLOGY,	16	SPINAL Cord,	15
HEART, Diseases of the,	16	STEAM-ENGINE,	32, 40
HISTOLOGY,	20	STRUCTURES, Design of,	21
HORACE, Works of,	50	STUDENTS' Text-Books,	17, 31, 32, 49
HYDRAULIC Power,	43	SURGERY, Civil,	12
HYGIENE and Public Health, . . .	10, 19	—Military,	19
INTEREST Tables,	59	—of Kidneys,	15
LABORATORY Handbooks—		—of Spinal Cord,	15
Histology,	20	SURVEYING,	23, 29
Pharmacy,	12	TEETH, Care of the,	18
Physiology,	20	THERMODYNAMICS, (Rankine),	40
LATIN Prosody,	55	TRAVERSE Tables,	29
LAW, Philosophy of,	55	VIRGIL, Works of,	50
LITERATURE, General,	58	ZOOLOGY,	19, 27
—Early Christian,	4		

CHARLES GRIFFIN & COMPANY'S LIST OF PUBLICATIONS.

RELIGIOUS WORKS.

ANECDOTES (CYCLOPÆDIA OF RELIGIOUS AND MORAL). With an Introductory Essay by the Rev. GEORGE CHEEVER, D.D. *Thirty-sixth Thousand.* Crown 8vo. Cloth, 3/6.
. These Anecdotes relate to no trifling subjects; and they have been selected, not for amusement, but for instruction. By those engaged in the tuition of the young, they will be found highly useful.

THE LARGE-TYPE BUNYAN.

BUNYAN'S PILGRIM'S PROGRESS. With Life and Notes, Experimental and Practical, by WILLIAM MASON. Printed in large type, and Illustrated with full-page Woodcuts. *Twelfth Thousand.* Crown 8vo. Bevelled boards, gilt, and gilt edges, 3/6.

CHRISTIAN YEAR (The): With Memoir of the Rev. JOHN KEBLE, by W. TEMPLE, Portrait, and Eight Engravings on Steel, after eminent Masters. *New Edition.* Small 8vo, toned paper. Cloth gilt, 5/.

Morocco elegant, 10/6.
Malachite, 12/6.

. The above is the only issue of the "Christian Year" with Memoir and Portrait of the Author. In ordering, Griffin's Edition should be specified.

CRUTTWELL (REV. CHARLES T., M.A.)
A HISTORY OF EARLY CHRISTIAN LITERATURE. In large 8vo, handsome cloth. [*In preparation.*]

. This work is intended not only for Theological Students, but for General Readers, and will be welcomed by all acquainted with the Author's admirable "*History of Roman Literature*," a work which has now reached its Fourth Edition.

DICK (Thos., LL.D.): CELESTIAL SCENERY; or, The Wonders of the Planetary System Displayed. This Work is intended for general readers, presenting to their view, in an attractive manner, sublime objects of contemplation. Illustrated. *New Edition.* Crown 8vo, toned paper. Handsomely bound, gilt edges, 5/.

LONDON: EXETER STREET, STRAND.

RELIGIOUS WORKS.

Now Ready. FOURTH AND GREATLY IMPROVED EDITION. In ROYAL 8VO.
Cloth Elegant, 6/. Gilt and Gilt Edges, 7/6.

THE STORY OF THE BIBLE,

From GENESIS to REVELATION.

Including the Historical Connection between the Old and New Testaments.
Told in Simple Language.

By CHARLES FOSTER.

With Maps and over 250 Engravings

(Many of them Full-page, after the Drawings of Professor CARL SCHÜNHERR and others),

*Illustrative of the Bible Narrative, and of Eastern
Manners and Customs.*

OPINIONS OF THE PRESS.

"A book which, once taken up, is not easily laid down. When the volume is opened, we are fairly caught. Not to speak of the well-executed wood engravings, which will each tell its story, we find a simple version of the main portions of the Bible, all that may most profitably be included in a work intended at once to instruct and charm the young—a version couched in the simplest, purest, most idiomatic English, and executed throughout with good taste, and in the most reverential spirit. *The work needs only to be known to make its way into families, and it will (at any rate, it ought to) become a favourite Manual in Sunday Schools.*"—*Scotsman*.

"A HOUSEHOLD TREASURE."—*Western Morning News*.

"This attractive and handsome volume . . . written in a simple and transparent style. . . . Mr. Foster's explanations and comments are MODELS OF TEACHING."—*Freeman*.

"This large and handsome volume, abounding in Illustrations, is just what is wanted. . . . The STORY is very beautifully and reverently told."—*Glasgow News*.

"There could be few better Presentation Books than this handsome volume."—*Daily Review*.

"WILL ACCOMPLISH A GOOD WORK."—*Sunday School Chronicle*.

"In this beautiful volume no more of comment is indulged in than is necessary to the elucidation of the text. Everything approaching Sectarian narrowness is carefully eschewed."—*Methodist Magazine*.

"This simple and impressive Narrative . . . succeeds thoroughly in riveting the attention of children; . . . admirably adapted for reading in the Home Circle."—*Daily Chronicle*.

"The HISTORICAL SKETCH connecting the Old and New Testaments is a very good idea; it is a common fault to look on these as distinct histories, instead of as parts of *one grand whole.*"—*Christian*.

"Sunday School Teachers and Heads of Families will best know how to value this handsome volume."—*Northern Whig*.

* * The above is the original English Edition. In ordering, Griffin's Edition, by Charles Foster, should be distinctly specified.

LONDON: EXETER STREET, STRAND.

STANDARD BIBLICAL WORKS

BY

THE REV. JOHN EADIE, D.D., LL.D.,

Late a Member of the New Testament Revision Company.

This Series has been prepared to afford sound and necessary aid to the Reader of Holy Scripture. The VOLUMES comprised in it form in themselves a COMPLETE LIBRARY OF REFERENCE. The number of Copies already issued greatly exceeds A QUARTER OF A MILLION.

I. EADIE (Rev. Prof.): BIBLICAL CYCLOPÆDIA (A); or, Dictionary of Eastern Antiquities, Geography, and Natural History, illustrative of the Old and New Testaments. With Maps, many Engravings, and Lithographed Fac-simile of the Moabite Stone. Large post 8vo, 700 pages. *Twenty-fifth Edition.*

Handsome cloth, 7/6.
 Morocco antique, gilt edges, 16/.

"By far the best Bible Dictionary for general use."—*Clerical Journal.*

II. EADIE (Rev. Prof.): CRUDEN'S CONCORDANCE TO THE HOLY SCRIPTURES. With Portrait on Steel, and Introduction by the Rev. Dr. KING. Post 8vo. *Fifty-third Edition.* Handsome cloth, 3/6.

* Dr. EADIE'S has long and deservedly borne the reputation of being the COMPLETEST and BEST CONCORDANCE extant.

III. EADIE (Rev. Prof.): CLASSIFIED BIBLE (The). An Analytical Concordance. Illustrated by Maps. Large Post 8vo. *Sixth Edition.* Handsome cloth, 8/6.

"We have only to add our unqualified commendation of a work of real excellence to every Biblical student."—*Christian Times.*

IV. EADIE (Rev. Prof.): ECCLESIASTICAL CYCLOPÆDIA (The). A Dictionary of Christian Antiquities, and of the History of the Christian Church. By the Rev. Professor EADIE, assisted by numerous Contributors. Large Post 8vo. *Sixth Edition.*

Handsome cloth, 8/6.

"The ECCLESIASTICAL CYCLOPÆDIA will prove acceptable both to the clergy and laity of Great Britain. A great body of useful information will be found in it."—*Athenæum.*

V. EADIE (Rev. Prof.): DICTIONARY OF THE HOLY BIBLE (A); for the use of Young People. With Map and Illustrations. Small 8vo. *Thirty-eighth Thousand.*

Cloth, elegant, 2/6.

LONDON: EXETER STREET, STRAND.

"No one who is in the habit of writing and speaking much on a variety of subjects can afford to dispense with Mr. SOUTHGATE'S WORKS."—*Glasgow News*.

THIRD EDITION.

SUGGESTIVE THOUGHTS ON RELIGIOUS SUBJECTS:

A Dictionary of Quotations and Selected Passages from nearly 1,000 of the best Writers, Ancient and Modern.

Compiled and Analytically Arranged

By HENRY SOUTHGATE.

In Square 8vo, elegantly printed on toned paper.

Presentation Edition, Cloth Elegant,	10/6.
Library Edition, Roxburghe,	12/.
Ditto, Morocco Antique,	20/.

"The topics treated of are as wide as our Christianity itself; the writers quoted from, of every Section of the one Catholic Church of JESUS CHRIST."—*Author's Preface*.

"Mr. Southgate's work has been compiled with a great deal of judgment, and it will, I trust, be extensively useful."—*Rev. Canon Liddon, D.D., D.C.L.*

"A casket of gems."—*English Churchman*.

"This is another of Mr. Southgate's most valuable volumes. . . . The mission which the Author is so successfully prosecuting in literature is not only highly beneficial, but necessary in this age. . . . If men are to make any acquaintance at all with the great minds of the world, they can only do so with the means which our Author supplies."—*Homilist*.

"Many a busy Christian teacher will be thankful to Mr. Southgate for having unearthed so many rich gems of thought; while many outside the ministerial circle will obtain stimulus, encouragement, consolation, and counsel, within the pages of this handsome volume."—*Nonconformist*.

"Mr. SOUTHGATE is an indefatigable labourer in a field which he has made peculiarly his own. . . . The labour expended on 'Suggestive Thoughts' must have been immense, and the result is as nearly perfect as human fallibility can make it. . . . Apart from the selections it contains, the book is of value as an index to theological writings. As a model of judicious, logical, and suggestive treatment of a subject, we may refer our readers to the manner in which the subject 'JESUS CHRIST' is arranged and illustrated in 'Suggestive Thoughts.'"—*Glasgow News*.

"Every day is a little life."—BISHOP HALL.

THE CHRISTIAN LIFE:

Thoughts in Prose and Verse from 500 of the Best Writers of all Ages.
Selected and Arranged for Every Day in the Year.

By MRS. H. SOUTHGATE.

Small 8vo. With Red Lines and unique Initial Letters on each page.
Cloth Elegant, 5/. *Second Edition*.

"A volume as handsome as it is intrinsically valuable."—*Scotsman*.

"The Readings are excellent."—*Record*.

"A library in itself."—*Northern Whig*.

LONDON: EXETER STREET, STRAND.

MIND IN MATTER:
A SHORT ARGUMENT ON THEISM.

BY THE
REV. JAMES TAIT.

Second Edition. Demy 8vo. Handsome Cloth, 8/6.

GENERAL CONTENTS.—Evolution in Nature and Mind—Mr. Darwin and Mr. Herbert Spencer—Inspiration, Natural and Supernatural—Deductions.

"An able and original contribution to Theistic literature. . . . The style is pointed, concise, and telling to a degree."—*Glasgow Herald*.

"Mr. TAIT advances many new and striking arguments . . . highly suggestive and fresh."—*Brit. Quarterly Review*.

THE MASSES:
HOW SHALL WE REACH THEM?

Some Hindrances in the way, set forth from the standpoint of the People, with
Comments and Suggestions.

BY
AN OLD LAY HELPER.

Cloth, 2s. 6d. *Second Edition.*

* * An attempt to set forth some deficiencies in our present methods of reaching the poor, in the language of the people themselves.

"So full of suggestiveness that we should reprint a tithe of the book if we were to transcribe all the extracts we should like to make."—*Church Bell*.

"'Hindrances in the way' exactly describes the subject-matter of the Book. Any one contemplating Missionary work in a large town would be helped by studying it."—*Guardian*.

"'The Masses' is a book to be well pondered over and acted upon."—*Church Work*.

"A very useful book, well worth reading."—*Church Times*.

"A most interesting book. . . . Contains a graphic description of work among the masses."—*English Churchman*.

WORDS AND WORKS OF OUR BLESSED LORD:
AND THEIR LESSONS FOR DAILY LIFE.

Two Vols. in One. Foolscap 8vo. Cloth, gilt edges, 6/.

LONDON: EXETER STREET, STRAND.

Works in Medicine, Surgery, and the Allied Sciences.

. *Special Illustrated Catalogue sent Gratis on application.*

WORKS

By SIR WILLIAM AITKEN, M.D., Edin., F.R.S.,

PROFESSOR OF PATHOLOGY IN THE ARMY MEDICAL SCHOOL; EXAMINER IN MEDICINE FOR THE MILITARY MEDICAL SERVICES OF THE QUEEN; FELLOW OF THE SANITARY INSTITUTE OF GREAT BRITAIN; CORRESPONDING MEMBER OF THE ROYAL IMPERIAL SOCIETY OF PHYSICIANS OF VIENNA; AND OF THE SOCIETY OF MEDICINE AND NATURAL HISTORY OF DRESDEN.

SEVENTH EDITION.

THE SCIENCE AND PRACTICE OF MEDICINE.

In Two Volumes, Royal 8vo., cloth. Illustrated by numerous Engravings on Wood, and a Map of the Geographical Distribution of Diseases. To a great extent Rewritten; Enlarged, Remodelled, and Carefully Revised throughout, 42/.

Opinions of the Press.

"The work is an admirable one, and adapted to the requirements of the Student, Professor, and Practitioner of Medicine. . . . The reader will find a large amount of information not to be met with in other books, epitomised for him in this. We know of no work that contains so much, or such full and varied information on all subjects connected with the Science and Practice of Medicine."—*Lancet*.

"The SEVENTH EDITION of this important Text-Book fully maintains its reputation. . . . Dr. Aitken is indefatigable in his efforts. . . . The section on DISEASES of the BRAIN and NERVOUS SYSTEM is completely remodelled, so as to include all the most recent researches, which in this department have been not less important than they are numerous."—*British Medical Journal*.

OUTLINES

OF THE

SCIENCE AND PRACTICE OF MEDICINE.

A TEXT-BOOK FOR STUDENTS.

Second Edition. Crown 8vo, 12/6.

"Students preparing for examinations will hail it as a perfect godsend for its conciseness."—*Athenaeum*.

"Well-digested, clear, and well-written, the work of a man conversant with every detail of his subject, and a thorough master of the art of teaching."—*British Medical Journal*.

LONDON: EXETER STREET, STRAND.

WORKS by A. WYNTER BLYTH, M.R.C.S., F.C.S.,
Public Analyst for the County of Devon, and Medical Officer of Health for
St. Marylebone.

I. FOODS: THEIR COMPOSITION AND ANALYSIS. Price 16/. In Crown 8vo, cloth, with Elaborate Tables and Litho-Plates. *Third Edition.* Revised and partly rewritten.

General Contents.

History of Adulteration—Legislation, Past and Present—Apparatus useful to the Food Analyst—"Ash"—Sugar—Confectionery—Honey—Treacle—Jams and Preserved Fruits—Starches—Wheat—Flour—Bread—Oats—Barley—Rye—Rice—Maize—Millet—Potato—Peas—Chinese Peas—Lentils—Beans—MILK—Cream—Butter—Cheese—Tea—Coffee—Cocoa and Chocolate—Alcohol—Brandy—Rum—Whisky—Gin—Arrack—Liqueurs—Beer—Wine—Vinegar—Lemon and Lime Juice—Mustard—Pepper—Sweet and Bitter Almond—Annatto—Olive Oil—Water. *Appendix:* Text of English and American Adulteration Acts.

"Will be used by every Analyst."—*Lancet*.

"STANDS UNRIVALED for completeness of information. . . . A really 'practical' work for the guidance of practical men."—*Sanitary Record*.

"An admirable digest of the most recent state of knowledge. . . . Interesting even to lay-readers."—*Chemical News*.

* The NEW EDITION contains many Notable Additions, especially on the subject of MILK and its relation to FEVER-EPIDEMICS, the PURITY of WATER-SUPPLY, the MARGARINE ACT, &c., &c.

COMPANION VOLUME.

II. POISONS: THEIR EFFECTS AND DETECTION. Price 16/.

General Contents.

Historical Introduction—Statistics—General Methods of Procedure—Life Tests—Special Apparatus—Classification: I.—ORGANIC POISONS; (a.) Sulphuric, Hydrochloric, and Nitric Acids, Potash, Soda, Ammonia, &c.; (b.) Petroleum, Benzene, Camphor, Alcohols, Chloroform, Carbolic Acid, Prussic Acid, Phosphorus, &c.; (c.) Hemlock, Nicotine, Opium, Strychnine, Aconite, Atropine, Digitalis, &c.; (d.) Poisons derived from Animal Substances; (e.) The Oxalic Acid Group. II.—INORGANIC POISONS: Arsenic, Antimony, Lead, Copper, Bismuth, Silver, Mercury, Zinc, Nickel, Iron, Chromium, Alkaline Earths, &c. *Appendix:* A. Examination of Blood and Blood-Spots. B. *Hints for Emergencies:* Treatment—Antidotes.

"Should be in the hands of every medical practitioner."—*Lancet*.

"A sound and practical Manual of Toxicology, which cannot be too warmly recommended. One of its chief merits is that it discusses substances which have been overlooked."—*Chemical News*.

"One of the best, most thorough, and comprehensive works on the subject."—*Saturday Review*.

HYGIENE AND PUBLIC HEALTH (a Dictionary of) : embracing the following subjects :—

I.—SANITARY CHEMISTRY: the Composition and Dietetic Value of Foods, with the Detection of Adulterations.

II.—SANITARY ENGINEERING: Sewage, Drainage, Storage of Water, Ventilation, Warming, &c.

III.—SANITARY LEGISLATION: the whole of the PUBLIC HEALTH ACT, together with portions of other Sanitary Statutes, in a form admitting of easy and rapid Reference.

IV.—EPIDEMIC AND EPIZOOTIC DISEASES: their History and Propagation, with the Measures for Disinfection.

V.—HYGIENE—MILITARY, NAVAL, PRIVATE, PUBLIC, SCHOOL.

Royal 8vo, 672 pp., cloth, with Map and 140 Illustrations, 28/.

"A work that must have entailed a vast amount of labour and research. . . . Will become a STANDARD WORK IN PUBLIC HEALTH."—*Medical Times and Gazette*.

"Contains a great mass of information of easy reference."—*Sanitary Record*.

LONDON: EXETER STREET, STRAND.

Now Ready. Large Crown 8vo. Handsome Cloth, 6s.

FOODS AND DIETARIES:

A Manual of Clinical Dietetics.

BY

R. W. BURNET, M.D.,

Member of the Royal College of Physicians of London; Physician to the Great Northern Central Hospital, &c.

In Dr. Burnet's "Foods and Dietaries," the *rationale* of the special dietary recommended, is briefly stated at the beginning of each section. To give definiteness to the directions, the HOURS of taking food and the QUANTITIES to be given at each time are stated, as well as the KINDS of food most suitable. In many instances there is also added a list of foods and dishes that are UNSUITABLE to the special case. References are given, where required, to the RECIPES for Invalid Cookery, which form the Appendix, and which have all been very carefully selected.

GENERAL CONTENTS.

DIET in Diseases of the Stomach, Intestinal Tract, Liver, Lungs and Pleura, Heart, Kidneys, &c.; in Diabetes, Scurvy, Anæmia, Sorofula, Gout (Chronic and Acute), Obesity, Acute and Chronic Rheumatism, Alcoholism, Nervous Disorders, Diathetic Diseases, Diseases of Children, with a Section on Prepared and Predigested Foods, and Appendix on Invalid Cookery.

"The directions given are UNIFORMLY JUDICIOUS and characterised by good-sense. May be confidently taken as a RELIABLE GUIDE in the art of feeding the sick."—*Brit. Med. Journal.*

"To all who have much to do with Invalids, Dr. Burnet's book will be of great use. . . . It will be found all the more valuable in that it deals with BROAD AND ACCEPTED VIEWS. There are large classes of disease which, if not caused solely by errors of diet, have a principal cause in such errors, and can only be removed by an intelligent apprehension of their relation to such. Gout, Scurvy, Rickets, and Alcoholism are instances in point, and they are all TREATED with ADMIRABLE SENSE and JUDGMENT by Dr. Burnet. He shows a desire to allow as much range and VARIETY as possible. The careful study of such books as this will very much help the Practitioner in the Treatment of cases, and powerfully aid the action of remedies."—*Lancet.*

"Dr. Burnet's work is intended to meet a want which is evident to all those who have to do with nursing the sick. . . . The plan is METHODOICAL, SIMPLE, and PRACTICAL. . . . Dr. Burnet takes the important diseases *seriatim* . . . and gives a Time-table of Diet, with Bill of Fare for each meal, quantities, and beverages. . . . An appendix of cookery for invalids is given, which will help the nurse when at her wits' end for a change of diet, to meet the urgency of the moment or tempt the capricious appetite of the patient."—*Glasgow Herald.*

LONDON: EXETER STREET, STRAND.

THIRD EDITION, *Pocket-Size, Leather, 8s. 6d. With very Numerous Illustrations.*

A SURGICAL HANDBOOK, For Practitioners, Students, House-Surgeons, and Dressers.

By F. M. CAIRD, M.B., F.R.C.S. (Ed.),

AND

C. W. CATHCART, M.B., F.R.C.S. (ENG. & ED.),

Assistant-Surgeons, Royal Infirmary, Edinburgh.

GENERAL CONTENTS.

Case-Taking—Treatment of Patients before and after Operation—Anæsthetics: General and Local—Antiseptics and Wound-Treatment—Arrest of Hæmorrhage—Shock and Wound Fever—Emergency Cases—Tracheotomy: Minor Surgical Operations—Bandaging—Fractures—Dislocations, Sprains, and Bruises—Extemporaneous Appliances and Civil Ambulance Work—Massage—Surgical Applications of Electricity—Joint-Fixation and Fixed Apparatus—The Syphon and its Uses—Trusses and Artificial Limbs—Plaster-Casting—Post-Mortem Examination—Sickroom Cookery Receipts, &c., &c., &c.

"THOROUGHLY PRACTICAL AND TRUSTWORTHY. Clear, accurate, succinct."—*The Lancet.*

"ADMIRABLY ARRANGED. The best practical little work we have seen. The matter is as good as the manner."—*Edinburgh Medical Journal.*

"THIS EXCELLENT LITTLE WORK. Clear, concise, and very readable. Gives attention to important details, often omitted, but ABSOLUTELY NECESSARY TO SUCCESS."—*Athenæum.*

"A dainty volume."—*Manchester Medical Chronicle.*

In Extra Crown 8vo, with Litho-plates and Numerous Illustrations. Cloth, 8s. 6d.

PHARMACY AND MATERIA MEDICA

(A Laboratory Course of):

Including the Principles and Practice of Dispensing.

Adapted to the Study of the British Pharmacopœia and the Requirements of the Private Student.

By W. ELBORNE, F.L.S., F.C.S.,

Late Assistant-Lecturer in Materia Medica and Pharmacy in the Owens College, Manchester.

"A work which we can very highly recommend to the perusal of all Students of Medicine. . . . ADMIRABLY ADAPTED to their requirements."—*Edinburgh Medical Journal.*

"Mr. Elborne evidently appreciates the Requirements of Medical Students, and there can be no doubt that any one who works through this Course will obtain an excellent insight into Chemical Pharmacy."—*British Medical Journal.*

"The system . . . which Mr. Elborne here sketches is thoroughly sound."—*Chemist and Druggist.*

LONDON: EXETER STREET, STRAND.

GRIFFIN'S MEDICAL SERIES.

Standard Works of Reference for Practitioners and Students,

ISSUED UNIFORMLY IN LIBRARY STYLE.

Large 8vo, Handsome Cloth, very fully Illustrated.

~~~~~  
*Full Catalogue, with Specimens of the Illustrations, sent Gratis on application.*  
~~~~~

VOLUMES ALREADY PUBLISHED.

HUMAN ANATOMY.

BY ALEXANDER MACALISTER, M.A., M.D., F.R.S., F.S.A.,

*Professor of Anatomy in the University of Cambridge, and
Fellow of St. John's College. 36s.*

"BY FAR THE MOST IMPORTANT WORK on this subject which has appeared in recent years."
—*The Lancet*.

"Destined to be a main factor in the advancement of Scientific Anatomy. . . . The
fine collection of Illustrations must be mentioned."—*Dublin Medical Journal*.

"This SPLENDID WORK"—*Saturday Review*.

HUMAN PHYSIOLOGY.

BY PROFESSOR LANDOIS OF GREIFSWALD

AND

WM. STIRLING, M.D., Sc.D.,

*Brackenbury Professor of Physiology in Owens College and Victoria University, Manchester;
Examiner in the University of Oxford. THIRD EDITION. 34s.*

"THE BOOK is the MOST COMPLETE *résumé* of all the facts in Physiology in the language.
Admirably adapted for the PRACTITIONER. . . . With this Text-book at command, NO
STUDENT COULD FAIL IN HIS EXAMINATION."—*The Lancet*.

"ONE of the MOST PRACTICAL WORKS on Physiology ever written. EXCELLENTLY CLEAR,
ATTRACTIVE, and SUCCINCT."—*British Medical Journal*.

EMBRYOLOGY (An Introduction to).

BY ALFRED C. HADDON, M.A., M.R.I.A.,

Professor of Zoology in the Royal College of Science, Dublin. 18s.

"AN EXCELLENT *RÉSUMÉ* OF RECENT RESEARCH, well adapted for self-study. . . . Gives
remarkably good accounts (including all recent work) of the development of the heart and
other organs. . . . The book is handsomely got up."—*The Lancet*.

LONDON: EXETER STREET, STRAND.

GRIFFIN'S MEDICAL SERIES—*Continued.***CLINICAL DIAGNOSIS.**

The Chemical, Microscopical, and Bacteriological Evidence of Disease.

By DR. VON JAKSCH, OF PRAGUE.

From the Second German Edition, by JAS. CAGNEY, M.A., M.D., of St. Mary's Hospital. With an Appendix by Prof. STIRLING, M.D., Sc.D.

With all the Original Illustrations, many printed in Colours. 25s.

"Prof. v. Jaksch's 'Clinical Diagnosis' stands almost alone in the width of its range, the THOROUGHNESS OF ITS EXPOSITION and the clearness of its style. . . . A STANDARD WORK, AS TRUSTWORTHY as it is scientific."—*Lancet*.**GOUT (A Treatise on).**

By SIR DYCE DUCKWORTH, M.D. EDIN., F.R.C.P.,

Physician to, and Lecturer on Clinical Medicine at, St. Bartholomew's Hospital. 25s.

"At once thoroughly practical and highly philosophical. The practitioner will find in it an ENORMOUS AMOUNT OF INFORMATION."—*Practitioner*.**RHEUMATISM AND RHEUMATOID ARTHRITIS.**

By ARCH. E. GARROD, M.A., M.D. OXON.,

Assistant-Physician to the West London Hospital, &c. 21s.

"We gladly welcome this Treatise. . . . The amount of information collected and the manner in which the facts are marshalled are deserving of ALL PRAISE."—*Lancet*.**DISEASES OF THE SKIN.**

By T. M'CALL ANDERSON, M.D.,

Professor of Clinical Medicine in the University of Glasgow. 25s.

"Beyond doubt, the MOST IMPORTANT WORK on Skin Diseases that has appeared in England for many years."—*British Medical Journal*.**DISEASES OF THE EYE.**

By DR. F. D. MEYER, OF PARIS.

From the Third French Edition,

By A. FREELAND FERGUS, M.B.,

Ophthalmic Surgeon, Glasgow Royal Infirmary. 25s.

"AN EXCELLENT TRANSLATION of a Standard French Text-Book. . . . Essentially a PRACTICAL WORK. The publishers have done their part in the tasteful and substantial manner characteristic of their medical publications."—*Ophthalmic Review*.

LONDON: EXETER STREET, STRAND.

GRIFFIN'S MEDICAL SERIES—*Continued.*

THE CENTRAL NERVOUS ORGANS (The Anatomy of), in Health and Disease.

BY PROFESSOR OBERSTEINER, OF VIENNA.

TRANSLATED BY ALEX. HILL, M.A., M.D.,

Master of Downing College, Cambridge. 25s.

"Dr. Hill has enriched the work with many Notes of his own. . . . Dr. Obersteiner's work is admirable. . . . INVALUABLE AS A TEXT-BOOK."—*British Medical Journal.*

MENTAL DISEASES:

With Special Reference to the Pathological Aspects of Insanity.

BY W. BEVAN LEWIS, L.R.C.P. (LOND.), M.R.C.S. (ENG.),

Medical Director of the West Riding Asylum, Wakefield. 28s.

"Without doubt the BEST WORK in English of its kind."—*Journal of Mental Science.*

"THIS ADMIRABLE TEXT-BOOK places the study of Mental Diseases on a SOLID BASIS. . . . The plates are numerous and admirable. To the student the work is INDISPENSABLE."
—*Practitioner.*

The SURGERY of the SPINAL CORD.

BY WILLIAM THORBURN, B.S., B.SC., M.D., F.R.C.S.,

Assistant-Surgeon to the Manchester Royal Infirmary. 12s. 6d.

"Really the FULLEST RECORD we have of Spinal Surgery, and marks an important advance."
—*British Medical Journal.*

RAILWAY INJURIES:

With Special Reference to those of the Back and Nervous System, in their Medico-Legal and Clinical Aspects.

BY HERBERT W. PAGE, M.A., M.C. (CANTAB), F.R.C.S. (ENG.),

Surgeon to St. Mary's Hospital; Dean, St. Mary's Hospital Medical School, &c., &c. 6s.

"A work INVALUABLE to those who have many railway cases under their care pending litigation. . . . A book which every lawyer as well as doctor should have on his shelves."
—*British Medical Journal.*

THE SURGERY OF THE KIDNEYS.

Being the Harvelan Lectures, 1889.

BY J. KNOWSLEY THORNTON, M.B., M.C.,

Surgeon to the Samaritan Free Hospital, &c.

In Demy. 8vo, with Illustrations, Cloth, 5s.

"The name and experience of the Author confer on the Lectures the stamp of authority."—
British Medical Journal.

LONDON: EXETER STREET, STRAND,

GRIFFIN'S MEDICAL SERIES—*Continued.*

TO BE ISSUED SHORTLY.

DISEASES OF THE HEART
(THE DIAGNOSIS OF).

BY A. ERNEST SANSON, M.D., F.R.C.P.,

Physician to the London Hospital; Consulting Physician, North-Eastern Hospital for Children;
Examiner in Medicine, Royal College of Physicians (Conjoint Board for England), and
University of Durham; Lecturer on Medical Jurisprudence and Public Health,
London Hospital Medical College, &c.[*Shortly.*]**GYNÆCOLOGY**

(A PRACTICAL TREATISE ON).

BY

JOHN HALLIDAY CROOM, M.D., F.R.C.P.E., F.R.C.S.E.,

Physician to the Royal Infirmary and Royal Maternity Hospital, Edinburgh; Examiner in
Midwifery, R.C.P., Edinburgh; Lecturer, Edinburgh School of Medicine, &c., &c.

WITH THE COLLABORATION OF

MM. JOHNSON SYMINGTON, M.D., F.R.C.S.E., AND

MILNE MURRAY, M.A., M.B., F.R.C.P.E.

[*Shortly.*]

. Volumes on other subjects in active preparation.

For a COMPLETE RECORD of the PAPERS read before the MEDICAL SOCIETIES throughout the United Kingdom during each year, vide "THE OFFICIAL YEAR-BOOK OF THE SCIENTIFIC AND LEARNED SOCIETIES OF GREAT BRITAIN AND IRELAND" (page 48).

"The value of these Lists of Papers can hardly be over-rated."—*Lancet.*

"INDISPENSABLE to any one who may wish to keep himself abreast of the Scientific work of the day."—*Edinburgh Med. Journal.*

LONDON: EXETER STREET. STRAND.

Griffin's Medical Students' Text-Books.

	PAGE
Anatomy,	PROF. MACALISTER, 13
Biology,	AINSWORTH DAVIS, 26
Botany (Elementary),	AINSWORTH DAVIS, 27
Brain, The—	
Central Nervous	
Organs,	OBERSTEINER AND HILL, 15
Mental Diseases, .	BEVAN LEWIS, 15
Chemistry—	
Inorganic,	DUPRÉ AND HAKE, 27
Qualitative Analysis,	PROF. SEXTON, 44
Quantitative „	PROF. SEXTON, 44
Electricity,	PROF. JAMIESON, 33
Embryology,	PROF. HADDON, 13
Eye, Diseases of the,	MEYER AND FERGUS, 14
Foods, Analysis of, .	WYNTER BLYTH, 10
Foods and Dietaries,	R. W. BURNET, 11
Gynæcology,	HALLIDAY CROOM, 16
Histology,	PROF. STIRLING, 20
Medicine,	SIR WM. AITKEN, 9
Nursing,	L. HUMPHRY, 18
Obstetrics,	H. G. LANDIS, 18
Pharmacy,	W. ELBORNE, 12
Physiology—	
Human,	LANDOIS AND STIRLING, 13
Practical,	PROF. STIRLING, 20
Poisons, Detection of,	WYNTER BLYTH, 10
Skin, Diseases of the,	PROF. ANDERSON, 14
Surgery—	
Civil,	CAIRD AND CATHCART, 12
Military,	PORTER-GODWIN, 19
Zoology,	SELENKA AND DAVIS, 27

THIRD EDITION. *In Extra Crown 8vo, with Numerous Illustrations, Cloth, 3s. 6d.*

NURSING (A Manual of):

Medical and Surgical.

BY LAURENCE HUMPHRY, M.A., M.B., M.R.C.S.,
Assistant-Physician to, and Lecturer to Probationers at, Addenbrooke's Hospital, Cambridge.

GENERAL CONTENTS.

The General Management of the Sick Room in Private Houses—General Plan of the Human Body—Diseases of the Nervous System—Respiratory System—Heart and Blood-Vessels—Digestive System—Skin and Kidneys—Fever—Diseases of Children—Wounds and Fractures—Management of Child-Bed—Sick-Room Cookery, &c., &c.

* * * A Full Prospectus Post Free on Application.

"In the fullest sense Mr. Humphry's book is a DISTINCT ADVANCE on all previous Manuals. . . . Its value is greatly enhanced by copious woodcuts and diagrams of the bones and internal organs, by many Illustrations of the art of BANDAGING, by Temperature charts indicative of the course of some of the most characteristic diseases, and by a goodly array of SICK-ROOM APPLIANCES with which EVERY NURSE should endeavour to become acquainted."—*British Medical Journal*.

"We should advise ALL NURSES to possess a copy of the work. We can confidently recommend it as an EXCELLENT GUIDE and companion."—*Hospital*.

LANDIS (Henry G., A.M., M.D., Professor of
Obstetrics in Starling Medical College):

THE MANAGEMENT OF LABOUR AND OF THE LYING-IN PERIOD. In 8vo, with Illustrations. Cloth, 7/6.

"Fully accomplishes the object kept in view by its author. . . . Will be found of GREAT VALUE by the young practitioner."—*Glasgow Medical Journal*.

LINN (S.H., M.D., D.D.S., Dentist to the Imperial
Medico-Chirurgical Academy of St. Petersburg):

THE TEETH: How to preserve them and prevent their Decay. A Popular Treatise on the Diseases and the Care of the Teeth. With Plates and Diagrams. Crown 8vo. Cloth, 2/6.

LONDON: EXETER STREET, STRAND.

LONGMORE (Surgeon-General, C.B., Q.H.S.,
F.R.C.S., &c., Professor of Military Surgery, Army Medical School):

THE SANITARY CONTRASTS OF THE CRIMEAN WAR.
Demy 8vo. Cloth limp, 1/6.

"A most valuable contribution to Military Medicine."—*British Medical Journal*.
"A most concise and interesting Review."—*Lancet*.

PARKER (Prof. W. Kitchen, F.R.S., Hunterian
Professor, Royal College of Surgeons):

MAMMALIAN DESCENT: being the Hunterian Lectures for 1884.
Adapted for General Readers. With Illustrations. In 8vo, cloth, 10/6.

"The smallest details of science catch a LIVING GLOW from the ardour of the author's imagination, . . . we are led to compare it to some quickening spirit which makes all the dry bones of skulls and skeletons stand up around him as an exceeding great army."—Prof. Romanes in *Nature*.

"Get this book; read it straight ahead, . . . you will first be interested, then absorbed; before reaching the end you will comprehend what a lofty ideal of creation is that of him, who, recognising the unity and the continuity of Nature, traces the gradual development of life from age to age . . . and has thus learned to 'look through Nature up to Nature's God.'"—*Scotsman*.

"A very striking book . . . as readable as a book of travels. Prof. PARKER is no Materialist."—*Leicester Post*.

FOURTH EDITION. Revised and enlarged. Foolscap 8vo, Roan, with 152 Illustrations and Folding-plate. 8s. 6d.

THE SURGEON'S POCKET-BOOK.

Specially adapted to the Public Medical Services.

BY SURGEON-MAJOR J. H. PORTER.

Revised and in great part rewritten

BY BRIGADE-SURGEON C. H. Y. GODWIN,
Assistant-Professor of Military Surgery in the Army Medical School.

"Every Medical Officer is recommended to have the 'Surgeon's Pocket-Book,' by Surgeon-Major Porter, accessible to refresh his memory and fortify his judgment."—*Precis of Field-Service Medical Arrangements for Afghan War*.

"The present editor—Brigade-Surgeon Godwin—has introduced so much that is new and practical, that we can recommend this 'Surgeon's Pocket-Book' as an INVALUABLE GUIDE to all engaged, or likely to be engaged, in Field Medical Service."—*Lancet*.

"A complete *vide mecum* to guide the military surgeon in the field."—*British Medical Journal*.

LONDON: EXETER STREET, STRAND.

WORKS

By WILLIAM STIRLING, M.D., Sc.D.,

Professor in the Victoria University, Brackenbury Professor of Physiology and Histology
in the Owens College, Manchester; and Examiner in the University of Oxford.

SECOND EDITION. *In Extra Crown 8vo, with 234 Illustrations, Cloth, 9s.*

PRACTICAL PHYSIOLOGY (Outlines of):

Being a Manual for the Physiological Laboratory, including
Chemical and Experimental Physiology, with
Reference to Practical Medicine.

PART I.—CHEMICAL PHYSIOLOGY.

PART II.—EXPERIMENTAL PHYSIOLOGY.

* * In the Second Edition, revised and enlarged, the number of Illustrations has been increased from 142 to 234.

"A VERY EXCELLENT AND COMPLETE TREATISE."—*Lancet*.

"The student is enabled to perform for himself most of the experiments usually shown in a systematic course of lectures on physiology, and the practice thus obtained must prove invaluable. . . . May be confidently recommended as a guide to the student of physiology, and, we doubt not, will also find its way into the hands of many of our scientific and medical practitioners."—*Glasgow Medical Journal*.

"This valuable little manual. . . . The GENERAL CONCEPTION of the book is EXCELLENT: the arrangement of the exercises is all that can be desired; the descriptions of experiments are CLEAR, CONCISE, and to the point."—*British Medical Journal*.

In Extra Crown 8vo, with 344 Illustrations, Cloth, 12s. 6d.

PRACTICAL HISTOLOGY (Outlines of):

A Manual for Students.

* * Dr. Stirling's "Outlines of Practical Histology" is a compact Handbook for students, providing a COMPLETE LABORATORY COURSE, in which almost every exercise is accompanied by a drawing. Very many of the illustrations have been prepared expressly for the work.

"The general plan of the work is ADMIRABLE. . . . It is very evident that the suggestions given are the outcome of a PROLONGED EXPERIENCE in teaching Practical Histology, combined with a REMARKABLE JUDGMENT in the selection of METHODS. . . . Merits the highest praise for the ILLUSTRATIONS, which are at once clear and faithful."—*British Medical Journal*.

"We can confidently recommend this small but CONCISELY-WRITTEN AND ADMIRABLY ILLUSTRATED work to students. They will find it to be a VERY USEFUL AND RELIABLE GUIDE in the laboratory, or in their own room. All the principal METHODS of preparing tissues for section are given, with such precise directions that little or no difficulty can be felt in following them in their most minute details. . . . The volume proceeds from a MASTER in his craft."—*Lancet*.

LONDON: EXETER STREET, STRAND.

GENERAL SCIENTIFIC WORKS

RELATING TO

CHEMISTRY (THEORETICAL AND APPLIED); ELECTRICAL
SCIENCE; ENGINEERING (CIVIL AND MECHANICAL);
GEOLOGY, &c.

THE DESIGN OF STRUCTURES:

A Practical Treatise on the Building of Bridges, Roofs, &c.

BY S. ANGLIN, C.E.,

Master of Engineering, Royal University of Ireland, late Whitworth Scholar, &c.

With very numerous Diagrams, Examples, and Tables.

Large Crown 8vo. Cloth, 16s.

The leading features in Mr. Anglin's carefully-planned "Design of Structures" may be briefly summarised as follows:—

1. It supplies the want, long felt among Students of Engineering and Architecture, of a concise Text-book on Structures, requiring on the part of the reader a knowledge of ELEMENTARY MATHEMATICS only.

2. The subject of GRAPHIC STATICS has only of recent years been generally applied in this country to determine the Stresses on Framed Structures; and in too many cases this is done without a knowledge of the principles upon which the science is founded. In Mr. Anglin's work the system is explained from FIRST PRINCIPLES and the Student will find in it a valuable aid in determining the stresses on all irregularly-framed structures.

3. A large number of PRACTICAL EXAMPLES, such as occur in the every-day experience of the Engineer, are given and carefully worked out, some being solved both analytically and graphically, as a guide to the Student.

4. The chapters devoted to the practical side of the subject, the Strength of Joints, Punching, Drilling, Rivetting, and other processes connected with the manufacture of Bridges, Roofs, and Structural work generally, are the result of MANY YEARS' EXPERIENCE in the bridge-yard; and the information given on this branch of the subject will be found of great value to the practical bridge-builder.

"Students of Engineering will find this Text-Book INVALUABLE"—*Architect.*

"The author has certainly succeeded in producing a THOROUGHLY PRACTICAL Text-Book."—*Builder.*

"We can unhesitatingly recommend this work not only to the Student, as the BEST TEXT-BOOK on the subject, but also to the professional engineer as an EXCEEDINGLY VALUABLE book of reference."—*Mechanical World.*

"This work can be CONFIDENTLY recommended to engineers. The author has wisely chosen to use as little of the higher mathematics as possible, and has thus made his book of REAL USE TO THE PRACTICAL ENGINEER. . . . After careful perusal, we have nothing but praise for the work."—*Nature.*

LONDON: EXETER STREET, STRAND.

With numerous Tables and Illustrations. Crown 8vo. Cloth, 10/6.
Second Edition; Revised.

ASSAYING (A Text-Book of):

For the use of Students, Mine Managers, Assayers, &c.

BY

C. BERINGER, F.I.C., F.C.S.,

Late Chief Assayer to the Rio Tinto Copper Company, London.

AND

J. J. BERINGER, F.I.C., F.C.S.,

Public Analyst for, and Lecturer to the Mining Association of, Cornwall.

General Contents.

PART I.—INTRODUCTORY: MANIPULATION: Sampling; Drying; Calculation of Results—Laboratory-books and Reports—METHODS: Dry Gravimetric; Wet Gravimetric—Volumetric Assays: Titrometric, Colorimetric, Gasometric—Weighing and Measuring—Reagents—Formulas, Equations, &c.—Specific Gravity.

PART II.—METALS: Detection and Assay of Silver, Gold, Platinum, Mercury, Copper, Lead, Thallium, Bismuth, Antimony, Iron, Nickel, Cobalt, Zinc, Cadmium, Tin, Tungsten, Titanium, Manganese, Chromium, &c.—Earths, Alkalies.

PART III.—NON-METALS: Oxygen and Oxides; The Halogens—Sulphur and Sulphates—Arsenic, Phosphorus, Nitrogen—Silicon, Carbon, Boron.

Appendix.—Various Tables useful to the Analyst.

"A REALLY MERITORIOUS WORK, that may be safely depended upon either for systematic instruction or for reference."—*Nature*.

"Of the fitness of the authors for the task they have undertaken, there can be no question. . . . Their book ADMIRABLY FULFILLS ITS PURPOSE. . . . The results given of an exhaustive series of experiments made by the authors, showing the effects of VARYING CONDITIONS on the accuracy of the method employed, are of THE UTMOST IMPORTANCE."—*Industries*.

In Preparation. Large 8vo.

PHOTOGRAPHY (A Text-Book of):

Its History, Processes, Apparatus, and Materials. Comprising
Working Details of all the more important Methods.

By A. BROTHERS, F.R.A.S.

With Illustrations by many of the Processes described.

LONDON: EXETER STREET, STRAND.

MINE-SURVEYING (A Text-Book of):

*For the use of Managers of Mines and Collieries, Students
at the Royal School of Mines, &c.*

BY BENNETT H. BROUGH, F.G.S.,
Instructor of Mine-Surveying, Royal School of Mines.

With Diagrams. SECOND EDITION. Crown 8vo. Cloth, 7s. 6d.

GENERAL CONTENTS.

General Explanations—Measurement of Distances—Miner's Dial—Variation of the Magnetic-Needle—Surveying with the Magnetic-Needle in presence of Iron—Surveying with the Fixed Needle—German Dial—Theodolite—Traversing Underground—Surface-Surveys with Theodolite—Plotting the Survey—Calculation of Areas—Levelling—Connection of Underground and Surface-Surveys—Measuring Distances by Telescope—Setting-out—Mine-Surveying Problems—Mine Plans—Applications of Magnetic-Needle in Mining—*Appendices.*

"It is the kind of book which has long been wanted, and no English-speaking Mine Agent or Mining Student will consider his technical library complete without it."—*Nature.*

"Supplies a long-felt want."—*Iron.*

"A valuable accessory to Surveyors in every department of commercial enterprise."—*Colliery Guardian.*

WORKS

BY WALTER R. BROWNE, M.A., M. INST. C.E.,
Late Fellow of Trinity College, Cambridge.

THE STUDENT'S MECHANICS:
An Introduction to the Study of Force and Motion.

With Diagrams. Crown 8vo. Cloth, 4s. 6d.

"Clear in style and practical in method, 'THE STUDENT'S MECHANICS' is cordially to be recommended from all points of view."—*Athenaeum.*

FOUNDATIONS OF MECHANICS.

Papers reprinted from the *Engineer*. In Crown 8vo, 1s.

FUEL AND WATER:

A Manual for Users of Steam and Water.

BY PROF. SCHWACKHÖFER AND W. R. BROWNE, M.A. (See p. 44).

LONDON: EXETER STREET, STRAND.

PRACTICAL GEOLOGY

(AIDS IN):

WITH A SECTION ON PALÆONTOLOGY.

BY

GRENVILLE A. J. COLE, F.G.S.,

Professor of Geology in the Royal College of Science for Ireland.

With Numerous Illustrations and Tables. Large Crown 8vo. Cloth, 10s. 6d.

THIS work is intended as a companion to any ordinary Text-book of Geology; and will be of special service to those students who have made excursions into the field, and who wish to determine their specimens for themselves.

A large section of the book has been devoted to rocks and to the ordinary minerals of the earth's crust, since these will always present themselves to the observer during any expedition or in any country.

The section on Blowpipe-work has been inserted as an aid to Travellers; while the description of the hard parts of fossil invertebrates will probably assist those readers who find it impossible to distinguish genera by means of mere names and figures.

GENERAL CONTENTS.

PART I.—SAMPLING OF THE EARTH'S CRUST.

Observations in the field.

Collection and packing of specimens.

PART II.—EXAMINATION OF MINERALS.

Some physical characters of minerals.

Simple tests with wet reagents.

Examination of minerals with the blowpipe.

Simple and characteristic reactions.

Blowpipe-tests.

Quantitative flame reactions of the felspars and their allies.

Examination of the optical properties of minerals.

PART III.—EXAMINATION OF ROCKS.

Introductory.

Rock-structures easily distinguished.

Some physical characters of rocks.

Chemical examination of rocks.

Isolation of the constituents of rocks.

The petrological microscope and microscopic preparations.

The more prominent characters to be observed in minerals in rock-sections.

Characters of the chief rock-forming minerals in the rock-mass and in thin sections.

Sedimentary rocks.

Igneous rocks.

Metamorphic rocks.

PART IV.—EXAMINATION OF FOSSILS.

Introductory.

Fossil generic types.—Rhisopoda; Spongiae;

Hydrozoa; Actinozoa.

Polyzoa; Brachiopoda.

Lamellibranchiata.

Scaphopoda; Gastropoda; Pteropoda; Cephalopoda.

Echinodermata; Vermes.

Anthropoda.

Suggested list of characteristic invertebrate fossils.

"A more useful work for the practical geologist has not appeared in handy form."—*Scottish Geographical Magazine.*

"This EXCELLENT MANUAL . . . will be a VERY GREAT HELP. . . . The section on the Examination of Fossils is probably the BEST of its kind yet published. . . . FULL of well-digested information from the newest sources and from personal research."—*Annals of Nat. History.*

LONDON: EXETER STREET, STRAND.

SEWAGE DISPOSAL WORKS:

**A GUIDE TO THE CONSTRUCTION OF WORKS FOR
THE PREVENTION OF THE POLLUTION BY
SEWAGE OF RIVERS AND ESTUARIES.**

BY

W. SANTO CRIMP, ASSOC. MEM. INST. C.E., F.G.S.,
Assistant-Engineer, London County Council.

With Tables, Illustrations in the Text, and 33 Lithographic Plates.
Medium 8vo. Handsome Cloth, 25s.

PART I.—INTRODUCTORY.

<p>Introduction. Details of River Pollutions and Recommendations of Various Commissions. Hourly and Daily Flow of Sewage. The Pail System as Affecting Sewage. The Separation of Rain-water from the Sewage Proper.</p>	<p>Settling Tanks. Chemical Processes. The Disposal of Sewage-sludge. The Preparation of Land for Sewage Disposal. Table of Sewage Farm Management.</p>
---	---

**PART II.—SEWAGE DISPOSAL WORKS IN OPERATION—THEIR
CONSTRUCTION, MAINTENANCE AND COST.**

Illustrated by Plates showing the General Plan and Arrangement adopted
in each District.

- | | |
|---|--|
| <ol style="list-style-type: none"> 1. Doncaster Irrigation Farm. 2. Beddington Irrigation Farm, Borough of Croydon. 3. Bedford Sewage Farm Irrigation. 4. Dewsbury and Hitchin Intermittent Filtration. 5. Merton, Croydon Rural Sanitary Authority. 6. Swanwick, Derbyshire. 7. The Ealing Sewage Works. 8. Chiswick. 9. Kingston-on-Thames, A. B. C. Process. 10. Salford Sewage Works. 11. Bradford, Precipitation. | <ol style="list-style-type: none"> 12. New Malden, Chemical Treatment and Small Filters. 13. Friern Barnet. 14. Acton, Ferozone and Polarite Process. 15. Ilford, Chadwell, and Dagenham Sewage Disposal Works. 16. Coventry. 17. Wimbledon. 18. Birmingham. 19. Newhaven. 20. Portsmouth. 21. Sewage Precipitation Works, Dortmund (Germany). 22. Treatment of Sewage by Electrolysis. |
|---|--|

"All persons interested in Sanitary Science owe a debt of gratitude to Mr. Crimp. . . . His work will be especially useful to SANITARY AUTHORITIES and their advisers EMINENTLY PRACTICAL AND USEFUL gives plans and descriptions of MANY OF THE MOST IMPORTANT SEWAGE WORKS of England with very valuable information as to the COST of construction and working of each. . . . The carefully-prepared drawings permit of an easy comparison between the different systems."—*Lancet*.

"Probably the MOST COMPLETE AND BEST TREATISE on the subject which has appeared in our language. . . . Will prove of the greatest use to all who have the problem of Sewage Disposal to face. . . . The general construction, drawings, and type are all excellent."—*Edinburgh Medical Journal*.

LONDON: EXETER STREET, STRAND.

WORKS

By J. R. AINSWORTH DAVIS, B.A.,

PROFESSOR OF BIOLOGY, UNIVERSITY COLLEGE, ABERYSTWYTH.

BIOLOGY (A Text-Book of):

Comprising Vegetable and Animal Morphology and Physiology. In Large Crown 8vo, with 158 Illustrations. Cloth, 12s. 6d.

GENERAL CONTENTS.

- PART I. VEGETABLE MORPHOLOGY AND PHYSIOLOGY.—Fungi—Algae—The Moss—The Fern—Gymnosperms—Angiosperms.
Comparative Vegetable Morphology and Physiology—Classification of Plants.
- PART II. ANIMAL MORPHOLOGY AND PHYSIOLOGY.—Protozoa—Coelenterata—Vermes—Arthropoda—Mollusca—Amphibia—Aves—Mammalia.
Comparative Animal Morphology and Physiology—Classification of Animals.
With Bibliography, Exam.-Questions, complete Glossary, and 158 Illustrations.

"As a general work of reference, Mr. Davis's manual will be HIGHLY SERVICEABLE to medical men."—*British Medical Journal*.

"Furnishes a clear and comprehensive exposition of the subject in a systematic form."—*Saturday Review*.

"Literally PACKED with information."—*Glasgow Medical Journal*.

THE FLOWERING PLANT,

AS ILLUSTRATING THE FIRST PRINCIPLES OF BOTANY.

Specially adapted for London Matriculation, S. Kensington, and University Local Examinations in Botany. Large Crown 8vo, with numerous Illustrations. 3s. 6d.

"It would be hard to find a Text-book which would better guide the student to an accurate knowledge of modern discoveries in Botany. . . . The SCIENTIFIC ACCURACY of statement, and the concise exposition of FIRST PRINCIPLES make it valuable for educational purposes. In the chapter on the Physiology of Flowers, an *admirable résumé* is given, drawn from Darwin, Hermann Müller, Kerner, and Lubbock, of what is known of the Fertilization of Flowers."—*Journal of the Linnean Society*.

"We are much pleased with this volume . . . the author's style is MOST CLEAR, and his treatment that of a PRACTISED INSTRUCTOR. . . . The Illustrations are very good, suitable and helpful. The Appendix on Practical Work will be INVALUABLE to the private student. . . . We heartily commend the work."—*Schoolmaster*.

. Recommended by the National Home-Reading Union; and also for use in the University Correspondence Classes.

LONDON: EXETER STREET, STRAND,

 PROF. DAVIS'S WORKS—Continued.

A ZOOLOGICAL POCKET-BOOK;
Or, Synopsis of Animal Classification.
Comprising Definitions of the Phyla, Classes, and Orders, with explanatory Remarks and Tables.

BY DR. EMIL SELENKA,

Professor in the University of Erlangen.

Authorised English translation from the Third German Edition. In Small Post 8vo. Interleaved for the use of Students. Limp Covers, 4s.

 "Dr. Selenka's Manual will be found useful by all Students of Zoology. It is a **COMPREHENSIVE** and **SUCCESSFUL** attempt to present us with a **SCHEME** of the **NATURAL** arrangement of the animal world."—*Edin. Med. Journal*.

 "Will prove very serviceable to those who are attending Biology Lectures. . . . The translation is accurate and clear."—*Lancet*.

INORGANIC CHEMISTRY (A Short Manual of).

 BY A. DUPRÉ, Ph.D., F.R.S., AND WILSON HAKE,
 Ph.D., F.I.C., F.C.S., of the Westminster Hospital Medical School.

With Coloured Plate of Spectra. Crown 8vo. Cloth, 7s. 6d.

 "A well-written, clear and accurate Elementary Manual of Inorganic Chemistry. . . . We agree heartily in the system adopted by Drs. Dupré and Hake. **WILL MAKE EXPERIMENTAL WORK TREBLY INTERESTING BECAUSE INTELLIGIBLE.**"—*Saturday Review*.

 "There is no question that, given the **PERFECT GROUNDING** of the Student in his Science, the remainder comes afterwards to him in a manner much more simple and easily acquired. **THE WORK IS AN EXAMPLE OF THE ADVANTAGES OF THE SYSTEMATIC TREATMENT** of a Science over the fragmentary style so generally followed. **BY A LONG WAY THE BEST** of the small Manuals for Students."—*Analyst*.

HINTS ON THE PRESERVATION OF FISH,

IN REFERENCE TO FOOD SUPPLY.

 BY J. COSSAR EWART, M.D., F.R.S.E.,
 Regius Professor of Natural History, University of Edinburgh.

 In Crown 8vo. Wrapper, 6d.

 LONDON: EXETER STREET, STRAND.

*Royal 8vo. With numerous Illustrations and 17 Lithographic Plates.
Handsome Cloth. Price 3os.*

BRIDGE-CONSTRUCTION

(A PRACTICAL TREATISE ON):

Being a Text-Book on the Construction of Bridges in
Iron and Steel.

FOR THE USE OF STUDENTS, DRAUGHTSMEN, AND ENGINEERS.

BY

T. CLAXTON FIDLER, M. INST. C.E.,

Prof. of Engineering, University College, Dundee.

"Of late years the American treatises on Practical and Applied Mechanics have taken the lead . . . since the opening up of a vast continent has given the American engineer a number of new bridge-problems to solve . . . but we look to the PRESENT TREATISE ON BRIDGE-CONSTRUCTION, and the Forth Bridge, to bring us to the front again."—*Engineer*.

"One of the VERY BEST RECENT WORKS on the Strength of Materials and its application to Bridge-Construction. . . . Well repays a careful Study."—*Engineering*.

"AN INDISPENSABLE HANDBOOK for the practical Engineer."—*Nature*.

"The science is progressive, and as an exposition of its LATEST ADVANCES we are glad to welcome Mr. Fidler's well-written treatise."—*Architect*.

"An admirable account of the theory and process of bridge-design, AT ONCE SCIENTIFIC AND THOROUGHLY PRACTICAL. It is a book such as we have a right to expect from one who is himself a substantial contributor to the theory of the subject, as well as a bridge-builder of repute."—*Saturday Review*.

"This book is a model of what an engineering treatise ought to be."—*Industries*.

"A SCIENTIFIC TREATISE OF GREAT MERIT."—*Westminster Review*.

"Of recent text-books on subjects of mechanical science, there has appeared no one more ABLE, EXHAUSTIVE, or USEFUL than Mr. Claxton Fidler's work on Bridge-Construction."—*Scotsman*.

LONDON: EXETER STREET, STRAND,

FOSTER (C. Le Neve, D.Sc., Professor of Mining,

Royal College of Science; H.M. Inspector of Mines, Llandudno) :

ORE AND STONE MINING (A Text-Book of). With numerous Illustrations. Large Crown 8vo. Cloth. [Shortly.]

GRIFFIN (John Joseph, F.C.S.) :

CHEMICAL RECREATIONS: A Popular Manual of Experimental Chemistry. With 540 Engravings of Apparatus. Tenth Edition. Crown 4to. Cloth.

Part I.—Elementary Chemistry, 2/-

Part II.—The Chemistry of the Non-Metallic Elements, including a Comprehensive Course of Class Experiments, 10/6.

Or, complete in one volume, cloth, gilt top, . . . 12/6.

GURDEN (Richard Lloyd, Authorised Surveyor

for the Governments of New South Wales and Victoria) :

TRAVERSE TABLES: computed to Four Places Decimals for every Minute of Angle up to 100 of Distance. For the use of Surveyors and Engineers. Second Edition. Folio, strongly half-bound, 21/.

* * * Published with Concurrence of the Surveyors-General for New South Wales and Victoria.

"Those who have experience in exact SURVEY-WORK will best know how to appreciate the enormous amount of labour represented by this valuable book. The computations enable the user to ascertain the sines and cosines for a distance of twelve miles to within half an inch, and this BY REFERENCE TO BUT ONE TABLE, in place of the usual Fifteen minute computations required. This alone is evidence of the assistance which the Tables ensure to every user, and as every Surveyor in active practice has felt the want of such assistance, few knowing of their publication will remain without them."—*Engineer*.

"We cannot sufficiently admire the heroic patience of the author, who, in order to prevent error, calculated each result by two different modes, and, before the work was finally placed in the Printers' hands, repeated the operation for a third time, on revising the proofs."—*Engineering*.

HUGHES (H. W., F.G.S.) :

COAL MINING (A Text-Book of). With numerous Illustrations and Tables. Large Crown 8vo. Cloth. [Shortly.]

Griffin's Standard Publications

FOR

ENGINEERS, ELECTRICIANS, ARCHITECTS, BUILDERS,
NAVAL CONSTRUCTORS, AND SURVEYORS.

		PAGE
Applied Mechanics, . . .	PROF. RANKINE, . . .	39
,, (Student's), . . .	W. R. BROWNE, . . .	23
Civil Engineering, . . .	PROF. RANKINE, . . .	39
Bridge-Construction, . . .	PROF. FIDLER, . . .	28
Design of Structures, . . .	S. ANGLIN, . . .	21
Sewage Disposal Works, . . .	SANTO CRIMP, . . .	25
Traverse Tables, . . .	R. GURDEN, . . .	29
Marine Engineering, . . .	A. E. SEATON, . . .	45
Stability of Ships, . . .	SIR. E. J. REED, . . .	41
The Steam-Engine, . . .	PROF. RANKINE, . . .	40
,, (Student's), . . .	PROF. JAMIESON, . . .	32
Boiler Construction, . . .	T. W. TRAILL, . . .	46
,, Management, . . .	R. D. MUNRO, . . .	33
Fuel and Water (for Steam Users), . . .	{ SCHWACKHÖFER AND BROWNE, . . . }	44
Machinery and Millwork, . . .	PROF. RANKINE, . . .	39
Hydraulic Machinery, . . .	PROF. ROBINSON, . . .	43
Useful Rules and Tables for Engineers, &c., . . .	{ PROFS. RANKINE AND JAMIESON, . . . }	40
Electrical Pocket-Book, . . .	MUNRO AND JAMIESON, . . .	35
Nystrom's Pocket-Book, . . .	DENNIS MARKS, . . .	35

For a COMPLETE RECORD of the PAPERS read before the ENGINEERING, ARCHITECTURAL, and ELECTRICAL SOCIETIES throughout the United Kingdom during each year, *vide* "THE OFFICIAL YEAR-BOOK OF THE SCIENTIFIC AND LEARNED SOCIETIES OF GREAT BRITAIN AND IRELAND" (page 48).

LONDON: EXETER STREET, STRAND.

Griffin's Standard Publications

FOR

**MINE OWNERS AND MANAGERS, GEOLOGISTS,
METALLURGISTS, AND MANUFACTURERS.**

	PAGE
Geology (Stratigraphical), R. ETHERIDGE, . . .	37
„ (Physical), . . .	36
„ (Practical), . . .	24
Mine-Surveying, . . .	23
Coal Mining, . . .	29
Ore and Stone Mining, . . .	29
Metallurgy, . . .	38
„ (Introduction to), . . .	42
Assaying, . . .	22
Electro-Metallurgy, . . .	34

Griffin's Students' Text-Books.

	PAGE		PAGE
Biology, Davis,	26	Magnetism and Electricity,	
Botany, Davis,	26	„ Jamieson,	33
Chemistry—		Mechanics, . . . Rankine,	40
Inorganic, Dupré & Hake,	27	Physics (Experiments),	
Qual. Analysis, Sexton,	44	„ Wright,	47
Quant. „ „	44	Physiology, . . . Stirling,	20
Recreations, Griffin,	29	Steam-Engine, Jamieson,	32
Experiments, Wright,	47	Zoology, Davis,	27

LONDON: EXETER STREET, STRAND.

WORKS

BY ANDREW JAMIESON, C.E., F.R.S.E.,
Professor of Engineering, Glasgow and West of Scotland Technical College.

FIFTH EDITION, Revised and Enlarged. Crown 8vo, Cloth, 7s. 6d.

A TEXT-BOOK ON STEAM AND STEAM-ENGINES.

WITH OVER 200 ILLUSTRATIONS, FOUR FOLDING-PLATES, AND
 EXAMINATION QUESTIONS.

"Professor Jamieson fascinates the reader by his CLEARNESS OF CONCEPTION AND SIMPLICITY OF EXPRESSION. His treatment recalls the lecturing of Faraday."—*Athenæum*.

"The BEST BOOK yet published for the use of Students."—*Engineer*.

"Undoubtedly the MOST VALUABLE AND MOST COMPLETE Hand-book on the subject that now exists."—*Marine Engineer*.

A POCKET-BOOK of ELECTRICAL RULES and TABLES.

FOR THE USE OF ELECTRICIANS AND ENGINEERS.

Pocket Size. Leather, 8s. 6d. *Seventh Edition*, revised and enlarged.
 (See under *Munro and Jamieson*.)

ELECTRICITY & MAGNETISM (An Advanced Text-Book on):

For the Use of Science and Art, City and Guilds of London, and other
 Students. With Illustrations.

[*Shortly*.]

PROF. JAMIESON'S ELEMENTARY MANUALS FOR FIRST-YEAR STUDENTS.

1. STEAM AND THE STEAM-ENGINE

(AN ELEMENTARY MANUAL ON):

Forming an Introduction to the larger Work by the same Author. With very
 numerous Illustrations and Examination Questions. *Second Edition*.
 Crown 8vo. Cloth, 3s. 6d.

"Quite the right sort of Book . . . well illustrated with good diagrams and drawings
 of real engines and details, all clearly and accurately lettered. . . . CANNOT FAIL TO BE
 A MOST SATISFACTORY GUIDE to the apprentice and Student."—*Engineer*.

"Should be in the hands of EVERY engineering apprentice."—*Practical Engineer*.

LONDON: EXETER STREET, STRAND.

PROF. JAMIESON'S ELEMENTARY MANUALS—Continued.

Crown 8vo, with very numerous Illustrations.

2. MAGNETISM AND ELECTRICITY

(AN ELEMENTARY MANUAL ON).

With very Numerous Diagrams and Examination Questions.

Part I.—Magnetism. 1s.

Part II.—Voltaic Electricity. 1s. 6d.

Part III.—Electro-Statics, or Frictional Electricity. 1s. 6d.

Or, Complete in One Volume, 3s. 6d.

"The arrangement is as good as it well can be, . . . the diagrams are EXCELLENT. . . . The subject treated as an essentially practical one, and very clear instructions given. Teachers are to be congratulated on having such a THOROUGHLY TRUSTWORTHY TEXT-BOOK at their disposal."—*Nature*.

"An excellent and very PRACTICAL elementary treatise."—*Electrical Review*.

"An ADMIRABLE Introduction to Magnetism and Electricity . . . the production of a skilled and experienced teacher. . . . Explained at every point by simple experiments, rendered easier by admirable illustrations."—*British Medical Journal*.

"A CAPITAL TEXT-BOOK. . . . The diagrams are an important feature."—*Schoolmaster*.

3. APPLIED MECHANICS (An Elementary Manual on).

With Diagrams and Examination Questions. Crown 8vo.

[*Shortly*].

In Crown 8vo, very fully Illustrated. Cloth, 3s. 6d.

STEAM - BOILERS :

THEIR DEFECTS, MANAGEMENT, AND CONSTRUCTION.

By R. D. MUNRO,

Engineer of the Scottish Boiler Insurance and Engine Inspection Co.

This work, which is written chiefly to meet the wants of Mechanics, Engine-keepers, and Boiler-attendants, also contains information of the first importance to every user of Steam-power. It is, above all, a PRACTICAL work written for PRACTICAL men, the language and rules being throughout of the simplest nature.

GENERAL CONTENTS.

Explosions caused by Overheating of Plates: (a) Shortness of Water: (b) Deposit—Explosions caused by Defective and Overloaded Safety-Valves—Area of Safety-Valves—Explosions caused by Corrosion—Explosions caused by Defective Design and Construction, &c., &c.

"The volume is a valuable companion for workmen and engineers engaged about Steam Boilers, and ought to be carefully studied, and ALWAYS AT HAND."—*Colliery Guardian*.

"The subjects referred to are handled in a trustworthy, clear, and practical manner. . . . The book is VERY USEFUL, especially to steam users, artisans, and young engineers."—*Engineer*.

LONDON: EXETER STREET, STRAND.

ELECTRO-METALLURGY (A Treatise on):

Embracing the Application of Electrolysis to the Plating, Depositing, Smelting, and Refining of various Metals, and to the Reproduction of Printing Surfaces and Art-Work, &c.

By WALTER G. McMILLAN, F.I.C., F.C.S.,

Chemist and Metallurgist to the Crossin's Foundry and Shell-Factory; La's Demonstrator of Metallurgy in King's College, London.

With numerous Illustrations. Large Crown 8vo. Cloth, 10s. 6d.

GENERAL CONTENTS.

<p>Introductory and Historical—Theoretical and General—Sources of Current—General Conditions to be observed in Electro-Plating—Plating Adjuncts and Disposition of Plant—Cleansing and Preparation of Work for the Depositing-Vat, and Subsequent Polishing of Plated Goods—Electro-Deposition of Copper—Electro-typing—Electro-Deposition of Silver—of Gold—of Nickel and Cobalt—of Iron—of Platinum, Zinc, Cadmium, Tin, Lead, Antimony, and Bismuth; Electro-ohromy</p>	<p>—Electro-Deposition of Alloys—Electro-Metallurgical Extraction and Refining Processes—Recovery of certain Metals from their Solutions or Waste Substances—Determination of the Proportion of Metal in certain Depositing Solutions—Glossary of Substances commonly employed in Electro-Metallurgy—Addenda: Various useful Tables—The Bronzing of Copper and Brass Surfaces—Antidotes to Poisons.</p>
--	---

"This excellent treatise, . . . one of the BEST and MOST COMPLETE manuals hitherto published on Electro-Metallurgy."—*Electrical Review*.

"Well brought up to date, including descriptions such as that of Elmore's recent process for the manufacture of seamless copper-tubes of extraordinary strength and tenacity by electro-deposition of the pure metal. . . . Illustrated by well-executed and effective engravings."—*Journal of Soc. of Chem. Industry*.

"This work will be a STANDARD."—*Jeweller*.

"Any metallurgical process which REDUCES the COST of production must of necessity prove of great commercial importance. . . . We recommend this manual to ALL who are interested in the PRACTICAL APPLICATION of electrolytic processes."—*Nature*.

LONDON: EXETER STREET, STRAND.

MUNRO & JAMIESON'S ELECTRICAL POCKET-BOOK.

SEVENTH EDITION, Revised and Enlarged.

A POCKET-BOOK

OF

ELECTRICAL RULES & TABLES

FOR THE USE OF ELECTRICIANS AND ENGINEERS.

BY

JOHN MUNRO, C.E., & ANDREW JAMIESON, C.E., F.R.S.E.

With Numerous Diagrams. Pocket Size. Leather, 8s. 6d.

This work is fully illustrated, and forms an extremely convenient **POCKET COMPANION** for reference on important points essential to **ELECTRICIANS AND ELECTRICAL ENGINEERS.**

GENERAL CONTENTS.

UNITS OF MEASUREMENT.
MEASURES.
TESTING.
CONDUCTORS.
DIELECTRICS.
SUBMARINE CABLES.
TELEGRAPHY.
ELECTRO-CHEMISTRY.

ELECTRO-METALLURGY.
BATTERIES.
DYNAMOS AND MOTORS.
TRANSFORMERS.
ELECTRIC LIGHTING.
MISCELLANEOUS.
LOGARITHMS.
APPENDICES.

"WONDERFULLY PERFECT. . . . Worthy of the highest commendation we can give it."—*Electrician.*

"The STERLING VALUE of Messrs. MUNRO and JAMIESON'S POCKET-BOOK."—*Electrical Review.*

NYSTROM'S POCKET-BOOK

OF

MECHANICS & ENGINEERING.

REVISED AND CORRECTED BY

W. DENNIS MARKS, PH.B., C.E. (YALE S.S.S.),

Whitney Professor of Dynamical Engineering, University of Pennsylvania.

Pocket Size. Leather, 15s. TWENTIETH EDITION. Revised and greatly enlarged.

LONDON: EXETER STREET, STRAND.

Demy 8vo, Handsome cloth, 18s.

PHYSICAL GEOLOGY AND PALÆONTOLOGY,

ON THE BASIS OF PHILLIPS.

BY

HARRY GOVIER SEELEY, F.R.S.,

PROFESSOR OF GEOGRAPHY IN KING'S COLLEGE, LONDON.

With Frontispiece in Chromo-Lithography, and Illustrations.

"It is impossible to praise too highly the research which PROFESSOR SEELEY'S 'PHYSICAL GEOLOGY' evidences. IT IS FAR MORE THAN A TEXT-BOOK—it is a DIRECTORY to the Student in prosecuting his researches."—*Extract from the Presidential Address to the Geological Society, 1885, by Rev. Professor Bonney, D.Sc., LL.D., F.R.S.*

"PROFESSOR SEELEY maintains in his 'PHYSICAL GEOLOGY' the high reputation he already deservedly bears as a Teacher. . . . It is difficult, in the space at our command, to do fitting justice to so large a work. . . . The final chapters, which are replete with interest, deal with the Biological aspect of Palæontology. Here we find discussed the origin, the extinction, succession, migration, persistence, distribution, relation, and variation of species—with other considerations, such as the Identification of Strata by Fossils, Homotaxis, Local Faunas, Natural History Provinces, and the relation of Living to Extinct forms."—*Dr. Henry Woodward, F.R.S., in the "Geological Magazine."*

"A deeply interesting volume, dealing with Physical Geology as a whole, and also presenting us with an animated summary of the leading doctrines and facts of Palæontology, as looked at from a modern standpoint."—*Scotsman.*

"PROFESSOR SEELEY'S work includes one of the most satisfactory Treatises on Lithology in the English language. . . . So much that is not accessible in other works is presented in this volume, that no Student [of Geology] can afford to be without it."—*American Journal of Engineering.*

"Geology from the point of view of Evolution."—*Westminster Review.*

"PROFESSOR SEELEY'S PHYSICAL GEOLOGY is full of instructive matter, whilst the philosophical spirit which it displays will charm many a reader. From early days the author gave evidence of a powerful and eminently original genius. No one has shown more convincingly than the author that, in all ways, the past contains within itself the interpretation of the existing world."—*Annals of Natural History.*

LONDON: EXETER STREET, STRAND.

Demy 8vo, Handsome cloth, 34s.

STRATIGRAPHICAL GEOLOGY AND PALÆONTOLOGY,

ON

THE BASIS OF PHILLIPS.

BY

ROBERT ETHERIDGE, F. R. S.,

OF THE NATURAL HIST. DEPARTMENT, BRITISH MUSEUM, LATE PALÆONTOLOGIST TO THE
GEOLOGICAL SURVEY OF GREAT BRITAIN, PAST PRESIDENT OF THE
GEOLOGICAL SOCIETY, ETC.

With Map, Numerous Tables, and Thirty-six Plates.

"In 1854 Prof. JOHN MORRIS published the Second Edition of his 'Catalogue of British Fossils,' then numbering 1,280 genera and 4,000 species. Since that date 3,000 genera and nearly 12,000 new species have been described, thus bringing up the muster-roll of extinct life in the British Islands alone to 3,680 genera and 16,000 known and described species.

"Numerous TABLES of ORGANIC REMAINS have been prepared and brought down to 1884, embracing the accumulated wealth of the labours of past and present investigators during the last thirty years. Eleven of these Tables contain every known British genus, zoologically or systematically placed, with the number of species in each, showing their broad distribution through time. The remaining 105 Tables are devoted to the analysis, relation, historical value, and distribution of specific life through each group of strata. These tabular deductions, as well as the Palæontological Analyses through the text, are, for the first time, fully prepared for English students."—*Extract from Author's Preface.*

* * * PROSPECTUS of the above important work—perhaps the MOST ELABORATE of its kind ever written, and one calculated to give a new strength to the study of Geology in Britain—may be had on application to the Publishers.

It is not too much to say that the work will be found to occupy a place entirely its own, and will become an indispensable guide to every British Geologist.

"No such compendium of geological knowledge has ever been brought together before."—*Westminster Review.*

"If Prof. SRELEY's volume was remarkable for its originality and the breadth of its views, Mr. ETHERIDGE fully justifies the assertion made in his preface that his book differs in construction and detail from any known manual. . . . Must take HIGH RANK AMONG WORKS OF REFERENCE."—*Athenæum.*

LONDON: EXETER STREET, STRAND.

THIRD EDITION, Revised by Mr. H. Bauerman, F.G.S.

ELEMENTS OF METALLURGY:

A PRACTICAL TREATISE ON THE ART OF EXTRACTING METALS
FROM THEIR ORES.

By J. ARTHUR PHILLIPS, M.Inst.C.E., F.C.S., F.G.S., &c.,

AND

H. BAUERMAN, V.P.G.S.

With Folding Plates and many Illustrations. Med. 8vo.
Handsome Cloth, 36s.

GENERAL CONTENTS.

Refractory Materials.	Antimony.	Iron.
Fire-Clays.	Arsenic.	Cobalt.
Fuels, &c.	Zinc.	Nickel.
Aluminium.	Mercury.	Silver.
Copper.	Bismuth.	Gold.
Tin.	Lead.	Platinum.

*. * Many NOTABLE ADDITIONS, dealing with new processes and developments, will be found in the New Edition.

"The value of this work is almost *inestimable*. There can be no question that the amount of time and labour bestowed on it is enormous. . . . There is certainly no Metallurgical Treatise in the language calculated to prove of such general utility."—*Mining Journal*.

"'Elements of Metallurgy' possesses intrinsic merits of the highest degree. Such a work is precisely wanted by the great majority of students and practical workers, and its very compactness is in itself a first-rate recommendation. The author has treated with great skill the metallurgical operations relating to all the principal metals. The methods are described with surprising clearness and exactness, placing an easily intelligible picture of each process even before men of less practical experience, and illustrating the most important contrivances in an excellent and perspicuous manner. . . . In our opinion the best work ever written on the subject with a view to its practical treatment."—*Westminster Review*.

"In this most useful and handsome volume is condensed a large amount of valuable practical knowledge. A careful study of the first division of the book, on Fuels, will be found to be of great value to every one in training for the practical applications of our scientific knowledge to any of our metallurgical operations."—*Athenæum*.

"A work which is equally valuable to the Student as a Text-book, and to the practical Smelter as a Standard Work of Reference. . . . The Illustrations are admirable examples of Wood Engraving."—*Chemical News*.

LONDON: EXETER STREET, STRAND,

SCIENTIFIC MANUALS

BY

W. J. MACQUORN RANKINE, C.E., LL.D., F.R.S.,

Late Regius Professor of Civil Engineering in the University of Glasgow.

THOROUGHLY REVISED BY W. J. MILLAR, C.E.,

Secretary to the Institute of Engineers and Shipbuilders in Scotland.

In Crown 8vo. Cloth.

I. RANKINE (Prof.): APPLIED MECHANICS:

comprising the Principles of Statics and Cinematics, and Theory of Structures, Mechanism, and Machines. With numerous Diagrams. *Twelfth Edition, 12/6.*

"Cannot fail to be adopted as a text-book. . . . The whole of the information is so admirably arranged that there is every facility for reference."—*Mining Journal.*

II. RANKINE (Prof.): CIVIL ENGINEERING:

comprising Engineering Surveys, Earthwork, Foundations, Masonry, Carpentry, Metal-work, Roads, Railways, Canals, Rivers, Water-works, Harbours, &c. With numerous Tables and Illustrations. *Seventeenth Edition, 16/.*

"Far surpasses in merit every existing work of the kind. As a manual for the hands of the professional Civil Engineer it is sufficient and unrivalled, and even when we say this, we fall short of that high appreciation of Dr. Rankine's labours which we should like to express."—*The Engineer.*

III. RANKINE (Prof.): MACHINERY AND

MILLWORK: comprising the Geometry, Motions, Work, Strength, Construction, and Objects of Machines, &c. Illustrated with nearly 300 Woodcuts. *Sixth Edition, 12/6.*

"Professor Rankine's 'Manual of Machinery and Millwork' fully maintains the high reputation which he enjoys as a scientific author; higher praise it is difficult to award to any book. It cannot fail to be a lantern to the feet of every engineer."—*The Engineer.*

LONDON: EXETER STREET, STRAND.

PROF. RANKINE'S WORKS—(*Continued*).

IV. RANKINE (Prof.): THE STEAM ENGINE and OTHER PRIME MOVERS. With Diagram of the Mechanical Properties of Steam, Folding-Plates, numerous Tables and Illustrations. *Thirteenth Edition, 12/6.*

V. RANKINE (Prof.): USEFUL RULES and TABLES for Engineers and others. With Appendix: TABLES, TESTS, and FORMULÆ for the use of ELECTRICAL ENGINEERS; comprising Submarine Electrical Engineering, Electric Lighting, and Transmission of Power. By ANDREW JAMIESON, C.E., F.R.S.E. *Seventh Edition, 10/6.*

"Undoubtedly the most useful collection of engineering data hitherto produced."—*Mining Journal.*

"Every Electrician will consult it with profit."—*Engineering.*

VI. RANKINE (Prof.): A MECHANICAL TEXT-BOOK. by Prof. MACQUORN RANKINE and E. F. BAMBER, C.E. With numerous Illustrations. *Third Edition, 9/.*

"The work, as a whole, is very complete, and likely to prove invaluable for furnishing a useful and reliable outline of the subjects treated of."—*Mining Journal.*

. THE MECHANICAL TEXT-BOOK forms a simple introduction to PROFESSOR RANKINE'S SERIES OF MANUALS ON ENGINEERING and MECHANICS.

VII. RANKINE (Prof.): MISCELLANEOUS SCIENTIFIC PAPERS. Royal 8vo. Cloth, 31/6.

Part I. Papers relating to Temperature, Elasticity, and Expansion of Vapours, Liquids, and Solids. Part II. Papers on Energy and its Transformations. Part III. Papers on Wave-Forms, Propulsion of Vessels, &c.

With Memoir by Professor TAIT, M.A. Edited by W. J. MILLAR, C.E. With fine Portrait on Steel, Plates, and Diagrams.

"No more enduring Memorial of Professor Rankine could be devised than the publication of these papers in an accessible form. . . . The Collection is most valuable on account of the nature of his discoveries, and the beauty and completeness of his analysis. . . . The Volume exceeds in importance any work in the same department published in our time."—*Architect.*

Royal 8vo, Handsome Cloth, 25s.

THE STABILITY OF SHIPS.

BY

SIR EDWARD J. REED, K.C.B., F.R.S., M.P.,

KNIGHT OF THE IMPERIAL ORDERS OF ST. STANILAUS OF RUSSIA; FRANCIS JOSEPH OF AUSTRIA; MEDJIDIE OF TURKEY; AND RISING SUN OF JAPAN; VICE-PRESIDENT OF THE INSTITUTION OF NAVAL ARCHITECTS.

With numerous Illustrations and Tables.

THIS work has been written for the purpose of placing in the hands of Naval Constructors, Shipbuilders, Officers of the Royal and Mercantile Marines, and all Students of Naval Science, a complete Treatise upon the Stability of Ships, and is the only work in the English Language dealing exhaustively with the subject.

The plan upon which it has been designed is that of deriving the fundamental principles and definitions from the most elementary forms of floating bodies, so that they may be clearly understood without the aid of mathematics; advancing thence to all the higher and more mathematical developments of the subject.

The work also embodies a very full account of the historical rise and progress of the Stability question, setting forth the results of the labours of BOUGUER, BERNOULLI, DON JUAN D'ULLOA, EULER, CHAPMAN, and ROMME, together with those of our own Countrymen, ATWOOD, MOSELEY, and a number of others.

The modern developments of the subject, both home and foreign, are likewise treated with much fullness, and brought down to the very latest date, so as to include the labours not only of DANGNIES, REECH (whose famous *Mémoire*, hitherto a sealed book to the majority of English naval architects, has been reproduced in the present work), RISBEC, FERRANTY, DUPIN, GUYOU, and DAYMARD, in France, but also those of RANKINE, WOOLLEY, ELGAR, JOHN, WHITE, GRAY, DENNY, INGLIS, and BENJAMIN, in Great Britain.

In order to render the work complete for the purposes of the Shipbuilder, whether at home or abroad, the Methods of Calculation introduced by Mr. F. K. BARNES, Mr. GRAY, M. REECH, M. DAYMARD, and Mr. BENJAMIN, are all given separately, illustrated by Tables and worked-out examples. The book contains more than 300 Diagrams, and is illustrated by a large number of actual cases, derived from ships of all descriptions, but especially from ships of the Mercantile Marine.

The work will thus be found to constitute the most comprehensive and exhaustive Treatise hitherto presented to the Profession on the Science of the STABILITY OF SHIPS.

"Sir EDWARD REED'S 'STABILITY OF SHIPS' is INVALUABLE. In it the STUDENT, new to the subject, will find the path prepared for him, and all difficulties explained with the utmost care and accuracy; the SHIP-DRAUGHTSMAN will find all the methods of calculation at present in use fully explained and illustrated, and accompanied by the Tables and Forms employed; the SHIPOWNER will find the variations in the Stability of Ships due to differences in forms and dimensions fully discussed, and the devices by which the state of his ships under all conditions may be graphically represented and easily understood; the NAVAL ARCHITECT will find brought together and ready to his hand, a mass of information which he would otherwise have to seek in an almost endless variety of publications, and some of which he would possibly not be able to obtain at all elsewhere."—*Steamship*.

"This IMPORTANT and VALUABLE WORK . . . cannot be too highly recommended to all connected with shipping interests."—*Iron*.

"This VERY IMPORTANT TREATISE, . . . the MOST INTELLIGIBLE, INSTRUCTIVE, and COMPLETE that has ever appeared."—*Nature*.

"The volume is an ESSENTIAL ONE for the shipbuilding profession."—*Westminster Review*.

LONDON: EXETER STREET, STRAND.

*In Large Crown 8vo, Handsome Cloth, with Numerous
Illustrations, 7s. 6d.*

METALLURGY

(AN INTRODUCTION TO THE STUDY OF).

BY

W. C. ROBERTS-AUSTEN, C.B., F.R.S.,

CHEMIST AND ASSAYER OF THE ROYAL MINT; PROFESSOR OF METALLURGY IN
THE ROYAL COLLEGE OF SCIENCE.

GENERAL CONTENTS.

RELATION OF METALLURGY TO CHEMISTRY.	MATERIALS AND PRODUCTS OF METALLURGICAL PROCESSES.
PHYSICAL PROPERTIES OF METALS.	FURNACES.
ALLOYS.	MEANS OF SUPPLYING AIR TO FURNACES.
THE THERMAL TREATMENT OF METALS.	TYPICAL METALLURGICAL PROCESSES.
FUEL.	ECONOMIC CONSIDERATIONS.

"No English text-book at all approaches this one either in its method of treatment, its general arrangement, or in the COMPLETENESS with which the most modern views on the subject are dealt with. Professor Austen's volume will be INVALUABLE, not only to the student, but also to those whose knowledge of the art is far advanced."—*Chemical News*.

"This volume amply realises the expectations formed as to the result of the labours of so eminent an authority. It is remarkable for its ORIGINALITY of conception and for the large amount of information which it contains. . . . The enormous amount of care and trouble expended upon it. . . . We recommend every one who desires information not only to consult, but to STUDY this work."—*Engineering*.

"Will at once take FRONT RANK as a text-book."—*Science and Art*.

LONDON: EXETER STREET, STRAND.

Medium 8vo, Handsome cloth, 25s.

HYDRAULIC POWER

AND

HYDRAULIC MACHINERY.

BY

HENRY ROBINSON, M. INST. C.E., F.G.S.,

FELLOW OF KING'S COLLEGE, LONDON; PROF. OF CIVIL ENGINEERING,
KING'S COLLEGE, ETC., ETC.

With numerous Woodcuts, and 43 Litbo. Plates.

GENERAL CONTENTS.

The Flow of Water under Pressure.	Hydraulic Coal-discharging Machines.
General Observations.	Hydraulic Machinery on board Ship.
Waterwheels.	Hydraulic Pile Driver.
Turbines.	Hydraulic Excavator.
Centrifugal Pumps.	Hydraulic Drill.
Water-pressure Pumps.	Hydraulic Brake.
The Accumulator.	Hydraulic Gun-Carriages.
Hydraulic Pumping-Engine.	Jets.
Three-Cylinder Engines and Capstans.	Hydraulic Ram.
Motors with Variable Power.	Packing.
Hydraulic Presses and Lifts.	Power Co-operation.
Movable Jigger Hoist.	Cost of Hydraulic Power.
Hydraulic Waggon Drop.	Tapping Pressure Mains.
The Flow of Solids.	Meters.
Shop Tools.	Waste Water Meter.
Cranes.	Pressure Reducing Valves.
Hydraulic Power applied to Bridges.	Pressure Regulator.
Dock-Gate Machinery.	

"A Book of great Professional Usefulness."—*Iron.*

A full Prospectus of the above important work—giving a description of the Plates—may be had on application to the Publishers.

LONDON: EXETER STREET, STRAND.

SCHWACKHÖFER and BROWNE:

FUEL AND WATER: A Manual for Users of Steam and Water.
By Prof. FRANZ SCHWACKHÖFER of Vienna, and WALTER R. BROWNE, M.A., C.E., late Fellow of Trinity College, Cambridge.
Demy 8vo, with Numerous Illustrations, 9/.

GENERAL CONTENTS.—Heat and Combustion—Fuel, Varieties of—Firing Arrangements: Furnace, Flues, Chimney—The Boiler, Choice of—Varieties—Feed-water Heaters—Steam Pipes—Water: Composition, Purification—Prevention of Scale, &c., &c.

"The Section on Heat is one of the best and most lucid ever written."—*Engineer*.

"Contains a vast amount of useful knowledge. . . . Cannot fail to be valuable to thousands compelled to use steam power."—*Railway Engineer*.

"Its practical utility is beyond question."—*Mining Journal*.

SHELTON-BEY (W. Vincent, Foreman to the Imperial Ottoman Gun Factories, Constantinople):

THE MECHANIC'S GUIDE: A Hand-Book for Engineers and Artizans. With Copious Tables and Valuable Recipes for Practical Use. Illustrated. *Second Edition*. Crown 8vo. Cloth, 7/6.

GENERAL CONTENTS.—Arithmetic—Geometry—Mensuration—Velocities in Boring and Wheel-Gearing—Wheel and Screw-Cutting—Miscellaneous Subjects and Useful Recipes—The Steam Engine—The Locomotive—Appendix: Tables for Practical Use.

"The MECHANIC'S GUIDE will answer its purpose as completely as a whole series of elaborate text-books."—*Mining Journal*.

WORKS by Prof. HUMBOLDT SEXTON, F.I.C., F.C.S., F.R.S.E., *Glasgow and West of Scotland Technical College.*

OUTLINES OF QUANTITATIVE ANALYSIS.

FOR THE USE OF STUDENTS.

With Illustrations. THIRD EDITION. Crown 8vo, Cloth, 3s.

"A practical work by a practical man . . . will further the attainment of accuracy and method."—*Journal of Education*.

"An ADMIRABLE little volume . . . well fulfils its purpose."—*Schoolmaster*.

"A COMPACT LABORATORY GUIDE for beginners was wanted, and the want has been WELL SUPPLIED. . . . A good and useful book."—*Lancet*.

"Mr. Sexton's book will be welcome to many teachers; for the processes are WELL CHOSFN, the principle which underlies each method is always CLEARLY EXPLAINED, and the directions are both SIMPLE and CLEAR."—*Brit. Med. Journal*.

BY THE SAME AUTHOR.

OUTLINES OF QUALITATIVE ANALYSIS.

FOR THE USE OF STUDENTS.

With Illustrations. SECOND EDITION. Crown 8vo, Cloth, 3s. 6d.

"The work of a thoroughly practical chemist . . . and one which may be unhesitatingly recommended."—*British Medical Journal*.

"Compiled with great care, and will supply a want."—*Journal of Education*.

LONDON: EXETER STREET, STRAND.

Now Ready, Ninth Edition, Revised and Enlarged, Price 18s.

Demy 8vo, Cloth. With Numerous Illustrations, reduced from Working Drawings.

A MANUAL OF MARINE ENGINEERING:

COMPRISING

THE DESIGNING, CONSTRUCTION, AND WORKING OF
MARINE MACHINERY.

BY A. E. SEATON,

Lecturer on Marine Engineering to the Royal Naval College, Greenwich; Member of the Inst. of Civil Engineers; Member of Council of the Inst. of Naval Architects; Member of the Inst. of Mech. Engineers, &c.

GENERAL CONTENTS.

Part I.—Principles of Marine Propulsion.	Pistons, Valves, Expansion Valves, &c.
Part II.—Principles of Steam Engineering.	Part IV.—Propellers.
Part III.—Details of Marine Engines: Design and Calculations for Cylinders,	Part V.—Boilers.
	Part VI.—Miscellaneous.

"In the three-fold capacity of enabling a Student to learn how to design, construct, and work a modern Marine Steam-Engine, Mr. Seaton's Manual has NO RIVAL as regards comprehensiveness of purpose and lucidity of treatment."—*Times*.

"The important subject of Marine Engineering is here treated with the THOROUGHNESS that it requires. No department has escaped attention. . . . Gives the results of much close study and practical work."—*Engineering*.

"By far the BEST MANUAL in existence. . . . Gives a complete account of the methods of solving, with the utmost possible economy, the problems before the Marine Engineer."—*Athenaeum*.

"The Student, Draughtsman, and Engineer will find this work the MOST VALUABLE HANDBOOK of Reference on the Marine Engine now in existence."—*Marine Engineer*.

LONDON: EXETER STREET, STRAND.

SECOND EDITION, Revised and Enlarged. Pocket-Size, Leather, also for Office Use, Cloth, 12s.

BOILERS, MARINE AND LAND; THEIR CONSTRUCTION AND STRENGTH.

A HANDBOOK OF RULES, FORMULÆ, TABLES, &C., RELATIVE TO MATERIAL,
SCANTLINGS, AND PRESSURES, SAFETY VALVES, SPRINGS,
FITTINGS AND MOUNTINGS, &C.

For the Use of all Steam-Users.

By T. W. TRAILL, M. INST. C. E., F. E. R. N.,

Engineer Surveyor-in-Chief to the Board of Trade.

. In the New Issue the subject-matter has been considerably extended; Tables have been added for Pressures up to 200 lbs. per square-inch, and some of the Tables have been altered, besides which new ones and other matter have been introduced, which have been specially prepared and computed for the SECOND EDITION.

"Very unlike any of the numerous treatises on Boilers which have preceded it. . . . Really use ul. . . . Contains an ENORMOUS QUANTITY OF INFORMATION arranged in a very convenient form. . . . Those who have to design boilers will find that they can settle the dimensions for any given pressure with almost no calculation with its aid. . . . A MOST USEFUL VOLUME . . . supplying information to be had nowhere else."—*The Engineer*.

"As a handbook of rules, formulæ, tables, &c., relating to materials, scantlings, and pressures, this work will prove MOST USEFUL. The name of the Author is a sufficient guarantee for its accuracy. It will save engineers, inspectors, and draughtsmen a vast amount of calculation."—*Nature*.

"Mr. Traill has done a very useful and unpretentious piece of work. Rules and tables are given in a way simple enough to be intelligible to the most unscientific engineer."—*Saturday Review*.

"By such an authority cannot but prove a welcome addition to the literature of the subject. In the hands of the practical engineer or boilermaker, its value as a ready, reliable, and widely comprehensive book of reference, must prove almost inestimable. . . . Will rank high as a standard work on the subject. We can strongly recommend it as being the MOST COMPLETE, eminently practical work on the subject."—*Marine Engineer*.

"To the engineer and practical boiler-maker it will prove INVALUABLE. Copious and carefully worked-out tables will save much of the calculating drudgery. . . . Many exceedingly useful and practical hints are given with regard to the treatment of iron and steel, which are exceedingly valuable, and the outcome of a wide experience. The tables in all probability are the most exhaustive yet published. . . . Certainly deserves a place on the shelf in the drawing office of every boiler shop."—*Practical Engineer*.

"We give it a hearty welcome. . . . A handy pocket book. . . . Our readers cannot do better than purchase a copy. Cheap at five times the price. The intelligent engineer can make a safe investment that will yield him a rich and satisfactory return."—*Engineers' Gazette*.

"From the author's well-known character for thoroughness and exactness, there is every reason to believe that the results given in the tables may be relied on. . . . The great experience of the author in all that relates to boiler construction constitutes him an authority that no one need be ashamed of quoting, and a guide as safe as any man in Britain."—*Shipping World*.

LONDON: EXETER STREET, STRAND.

With very Numerous Illustrations, in large Crown 8vo, Handsome Cloth, 6s.
Also Presentation Edition, Gilt and Gilt Edges, 7s. 6d.

THE THRESHOLD OF SCIENCE:

A VARIETY OF EXPERIMENTS (Over 400)

ILLUSTRATING

SOME OF THE CHIEF PHYSICAL AND CHEMICAL PROPERTIES OF SURROUNDING OBJECTS,
AND THE EFFECTS UPON THEM OF LIGHT AND HEAT.

BY

C. R. ALDER WRIGHT, D.Sc., F.R.S.,

Lecturer on Chemistry and Physics in St. Mary's Hospital Medical School, London.

In this work the object aimed at is to provide a kind of "Playbook," which, in addition to affording the means of amusement, shall also to some extent tend in the direction of the course of mental education advocated by the British Association Committee, so that whilst the young philosopher finds pastime and entertainment in constructing simple apparatus and preparing elementary experiments, he may at the same time be led to observe correctly what happens, to draw inferences and make deductions therefrom.

"An ADMIRABLE COLLECTION of Physical and Chemical Experiments . . . a large proportion of these may be performed at home without any costly apparatus."—*Journal of Education*.

"Just the kind of book to add to a school library."—*Manchester Guardian*.

"Clear, terse, and attractive, the volume is to be most highly recommended."—*Public Opinion*.

"Dr. Alder Wright has accomplished a task that will win for him the hearts of all intelligent youths with scientific leanings. . . . Step by step the learner is here gently guided through the paths of science, made easy by the perfect knowledge of the teacher, and made flowery by the most striking and curious experiments. Well adapted to become the TREASURED FRIEND of many a bright and promising lad."—*Manchester Examiner*.

"The work is quite as instructive as it is entertaining. . . . The language throughout is clear and simple."—*School Guardian*.

"From the nature of gases to the making of soap-bubbles, from the freezing of water to the principles of 'pin-hole' photography, Dr. Alder Wright's book is an authority."—*Liverpool Mercury*.

LONDON: EXETER STREET, STRAND.

Eighth Annual Issue. Now Ready.

THE OFFICIAL YEAR-BOOK

OF THE

SCIENTIFIC AND LEARNED SOCIETIES OF GREAT
BRITAIN AND IRELAND. PRICE 7/6.

COMPILED FROM OFFICIAL SOURCES.

Comprising (together with other Official Information) LISTS of the PAPERS read during 1890 before the ROYAL SOCIETIES of LONDON and EDINBURGH, the ROYAL DUBLIN SOCIETY, the BRITISH ASSOCIATION, and all the LEADING SOCIETIES throughout the Kingdom engaged in the following Departments of Research:—

- | | |
|--|---|
| § 1. Science Generally: i.e., Societies occupying themselves with several Branches of Science, or with Science and Literature jointly. | § 6. Economic Science and Statistics. |
| § 2. Mathematics and Physics. | § 7. Mechanical Science and Architecture. |
| § 3. Chemistry and Photography. | § 8. Naval and Military Science. |
| § 4. Geology, Geography, and Mineralogy. | § 9. Agriculture and Horticulture. |
| § 5. Biology, including Microscopy and Anthropology. | § 10. Law. |
| | § 11. Medicine. |
| | § 12. Literature. |
| | § 13. Psychology. |
| | § 14. Archæology. |

"The YEAR-BOOK OF SOCIETIES is a Record which ought to be of the greatest use for the progress of Science."—*Sir Lyon Playfair, F.R.S., K.C.B., M.P., Past-President of the British Association.*

"It goes almost without saying that a Handbook of this subject will be in time one of the most generally useful works for the library or the desk."—*The Times.*

"The YEAR-BOOK OF SOCIETIES meets an obvious want, and promises to be a valuable work of reference."—*Athenæum.*

"The YEAR-BOOK OF SCIENTIFIC AND LEARNED SOCIETIES meets a want, and is therefore sure of a welcome."—*Westminster Review.*

"In the YEAR-BOOK OF SOCIETIES we have the FIRST ISSUE of what is, without doubt, a very useful work."—*Spectator.*

"The YEAR-BOOK OF SOCIETIES fills a very real want. The volume will become a Scientific Directory, chronicling the work and discoveries of the year, and enabling the worker in one branch to try his hand in all that interests him in kindred lines of research. We trust that it will meet with an encouraging reception."—*Engineering.*

"The OFFICIAL YEAR-BOOK OF SOCIETIES, which has been prepared to meet a want long felt by scientific workers of a Representative Book, will form a yearly record of Scientific Progress, and a Handbook of Reference. . . . It is carefully printed, and altogether well got up."—*Public Opinion.*

Copies of the FIRST ISSUE, giving an Account of the History, Organisation, and Conditions of Membership of the various Societies [with Appendix on the Leading Scientific Societies throughout the world], and forming the groundwork of the Series, may still be had, price 7/6. *Also Copies of the following Issues.*

The YEAR-BOOK OF SOCIETIES forms a complete INDEX TO THE SCIENTIFIC WORK of the year in the various Departments. It is used as a ready HANDBOOK in all our great SCIENTIFIC CENTRES, MUSEUMS, and LIBRARIES throughout the Kingdom, and will, without doubt, become an INDISPENSABLE BOOK OF REFERENCE to every one engaged in Scientific Work.

"We predict that the YEAR-BOOK OF SOCIETIES will speedily become one of those Year-Books WHICH IT WOULD BE IMPOSSIBLE TO DO WITHOUT."—*Bristol Mercury.*

LONDON: EXETER STREET, STRAND.

EDUCATIONAL WORKS.

*** Specimen Copies of all the Educational Works published by Messrs. Charles Griffin and Company may be seen at the Libraries of the College of Preceptors, South Kensington Museum, and Crystal Palace; also at the depôts of the Chief Educational Societies.*

Griffin's Standard Classical Works.

	PAGE
Prehistoric Antiquities, . . .	SCHRADER and JEVONS, . . . 56
Greek Antiquities, . . .	F. B. JEVONS, 54
Roman Antiquities, . . .	Prof. RAMSAY, 55
,, Elementary,	Prof. RAMSAY, 55
Greek Literature, . . .	F. B. JEVONS, 54
Roman Literature, . . .	Rev. C. T. CRUTTWELL, . . 52
,, Specimens of,	CRUTTWELL and BANTON, . 52
Greek Geography and My- thology,	DOERING and GRÆME, . . 53
Latin Prosody,	Prof. RAMSAY, 55
,, Elementary,	Prof. RAMSAY, 55
Virgil: Text and Notes (Illustrated),	Dr. BRYCE, 50
Horace: Text and Notes (Illustrated),	JOS. CURRIE, 50

BRYCE (Archibald Hamilton, D.C.L., LL.D.,
Senior Classical Moderator in the University of Dublin):

THE WORKS OF VIRGIL. Text from HEYNE and WAGNER.
English Notes, original, and selected from the leading German and
English Commentators. Illustrations from the antique. Complete in
One Volume. *Fourteenth Edition.* Fcap 8vo. Cloth, 6/.

Or, in Three Parts:

Part I. BUCOLICS and GEORGICS, . . . 2/6.

Part II. THE ÆNEID, Books I.-VI., . . . 2/6.

Part III. THE ÆNEID, Books VII.-XII., . . . 2/6.

"Contains the pith of what has been written by the best scholars on the subject.
The notes comprise everything that the student can want."—*Athenæum*.
"The most complete, as well as elegant and correct edition of Virgil ever published in
this country."—*Educational Times*.
"The best commentary on Virgil which a student can obtain."—*Scotsman*.

COBBETT (William): ENGLISH GRAMMAR,
in a Series of Letters, intended for the use of Schools and Young Persons
in general. With an additional chapter on Pronunciation, by the Author's
Son, JAMES PAUL COBBETT. *The only correct and authorised Edition.*
Fcap 8vo. Cloth, 1/6.

COBBETT (William): FRENCH GRAMMAR.
Fifteenth Edition. Fcap 8vo. Cloth, 3/6.

"Cobbett's 'French Grammar' comes out with perennial freshness. There are few
grammars equal to it for those who are learning, or desirous of learning, French without
a teacher. The work is excellently arranged, and in the present edition we note certain
careful and wise revisions of the text."—*School Board Chronicle*.

COBBIN'S MANGNALL: MANGNALL'S
HISTORICAL AND MISCELLANEOUS QUESTIONS, for the use
of Young People. By RICHMAL MANGNALL. Greatly enlarged and
corrected, and continued to the present time, by INGRAM COBBIN, M.A.
Fifty-fourth Thousand. New Illustrated Edition. 12mo. Cloth, 4/.

COLERIDGE (Samuel Taylor): A DISSER-
TATION ON THE SCIENCE OF METHOD. (*Encyclopædia*
Metropolitana.) With a Synopsis. *Ninth Edition.* Cr. 8vo. Cloth, 2/.

CURRIE (Joseph, formerly Head Classical
Master of Glasgow Academy):

THE WORKS OF HORACE: Text from ORELLIUS. English
Notes, original, and selected from the best Commentators. Illustrations
from the antique. Complete in One Volume. Fcap 8vo. Cloth, 5/.

Or in Two Parts:

Part I.—CARMINA, 3/.

Part II.—SATIRES AND EPISTLES, 3/.

"The notes are excellent and exhaustive."—*Quarterly Journal of Education*.

CRAIK'S ENGLISH LITERATURE.

A COMPENDIOUS HISTORY OF ENGLISH LITERATURE AND OF THE ENGLISH LANGUAGE FROM THE NORMAN CONQUEST. With numerous Specimens. By **GEORGE LILLIE CRAIK, LL.D.**, late Professor of History and English Literature, Queen's College, Belfast. *New Edition.* In two vols. Royal 8vo. Handsomely bound in cloth, 25/.

GENERAL CONTENTS.

INTRODUCTORY.

- I.—THE NORMAN PERIOD—The Conquest.
- II.—SECOND ENGLISH—Commonly called Semi-Saxon.
- III.—THIRD ENGLISH—Mixed, or Compound English.
- IV.—MIDDLE AND LATTER PART OF THE SEVENTEENTH CENTURY.
- V.—THE CENTURY BETWEEN THE ENGLISH REVOLUTION AND THE FRENCH REVOLUTION.
- VI.—THE LATTER PART OF THE EIGHTEENTH CENTURY.
- VII.—THE NINETEENTH CENTURY (a) THE LAST AGE OF THE GEORGES. (b) THE VICTORIAN AGE.

With numerous Excerpts and Specimens of Style.

"Anyone who will take the trouble to ascertain the fact, will find how completely even our great poets and other writers of the last generation have already faded from the view of the present, with the most numerous class of the educated and reading public. Scarcely anything is generally read except the publications of the day. YET NOTHING IS MORE CERTAIN THAN THAT NO TRUE CULTIVATION CAN BE SO ACQUIRED. This is the extreme case of that entire ignorance of history which has been affirmed, not with more point than truth, to leave a person always a child. . . . The present work combines the HISTORY OF THE LITERATURE with the HISTORY OF THE LANGUAGE. The scheme of the course and revolutions of the language which is followed here is extremely simple, and resting not upon arbitrary, but upon natural or real distinctions, gives us the only view of the subject that can claim to be regarded as of a scientific character."—*Extract from the Author's Preface.*

"Professor Craik has succeeded in making a book more than usually agreeable."—*The Times.*

Crown 8vo. Cloth, 7/6. TENTH EDITION.

A MANUAL OF ENGLISH LITERATURE,

for the use of Colleges, Schools, and Civil Service Examinations. Selected from the larger work, by Dr. CRAIK. *Tenth Edition.* With an Additional Section on Recent Literature, by HENRY CRAIK, M.A., Author of "A Life of Swift."

"A Manual of English Literature from so experienced and well-read a scholar as Professor Craik needs no other recommendation than the mention of its existence."—*Spectator.*

"This augmented effort will, we doubt not, be received with decided approbation by those who are entitled to judge, and studied with much profit by those who want to learn. . . . If our young readers will give healthy perusal to Dr. Craik's work, they will greatly benefit by the wide and sound views he has placed before them."—*Athenaeum.*

"The preparation of the NEW ISSUE has been entrusted to Mr. HENRY CRAIK, Secretary to the Scotch Education Department, and well known in literary circles as the author of the latest and best Life of Swift. . . . A Series of TEST QUESTIONS is added, which must prove of great service to Students studying alone."—*Glasgow Herald.*

LONDON: EXETER STREET, STRAND.

WORKS BY REV. C. T. CRUTTWELL, M.A.,
Late Fellow of Merton College, Oxford.

A HISTORY OF ROMAN LITERATURE:

From the Earliest Period to the Times of the Antonines.

Fourth Edition. Crown 8vo. Cloth, 8/6.

"Mr. CRUTTWELL has done a real service to all Students of the Latin Language and Literature. . . . Full of good scholarship and good criticism."—*Athenæum*.

"A most serviceable—indeed, indispensable—guide for the Student. . . . The 'general reader' will be both charmed and instructed."—*Saturday Review*.

"The Author undertakes to make Latin Literature interesting, and he has succeeded. There is not a dull page in the volume."—*Academy*.

"The great merit of the work is its fulness and accuracy."—*Guardian*.

"This elaborate and careful work, in every respect of high merit. Nothing at all equal to it has hitherto been published in England."—*British Quarterly Review*.

Companion Volume. Second Edition.

SPECIMENS OF ROMAN LITERATURE:

From the Earliest Period to the Times of the Antonines.

Passages from the Works of Latin Authors, Prose Writers, and Poets:

Part I.—ROMAN THOUGHT: Religion, Philosophy and Science, Art and Letters, 6/.

Part II.—ROMAN STYLE: Descriptive, Rhetorical, and Humorous Passages, 5/.

Or in One Volume complete, 10/6.

Edited by C. T. CRUTTWELL, M.A., Merton College, Oxford; and PEAKE BANTON, M.A., some time Scholar of Jesus College, Oxford.

"'Specimens of Roman Literature' marks a new era in the study of Latin."—*English Churchman*.

"A work which is not only useful but necessary. . . . The plan gives it a standing-ground of its own. . . . The sound judgment exercised in plan and selection calls for hearty commendation."—*Saturday Review*.

"It is hard to conceive a completer or handier repertory of specimens of Latin thought and style."—*Contemporary Review*.

* * KEY to PART II., PERIOD II. (being a complete TRANSLATION of the 85 Passages composing the Section), by THOS. JOHNSTON, M.A., may now be had (by Tutors and Schoolmasters only) on application to the Publishers. Price 2/6.

A HISTORY OF EARLY CHRISTIAN LITERATURE:

For the use of Students and General Readers.

8vo, Handsome Cloth.

[*In Preparation.*]

LONDON: EXETER STREET, STRAND.

HELLAS:**AN INTRODUCTION TO GREEK ANTIQUITIES,***Comprising the Geography, Religion and Myths, History, Art and Culture of old Greece.*On the Basis of the German Work by E. DOERING,
With Additions by ELLIOTT GRÆME.*In Large 8vo, with Map and Illustrations.***PART I.**

The Land and the People: the Religion and Myths of Old Greece.

. In the English version of Mr. Doering's work, the simple and interesting style of the original—written for young Students—has been retained; but, throughout, such additions and emendations have been made as render the work suitable for more advanced Students, and for all who desire to obtain, within moderate compass, more than a superficial acquaintance with the great People whose genius and culture have so largely influenced our own. The results of the latest researches by Dr. SCHLIERMANN, MM. FOUQUÉ, CARAPANOS, and others, are incorporated. [*Shortly.*]

D'ORSEY (Rev. Alex. J. D., B.D., Corpus
Christi Coll., Cambridge, Lecturer at King's College, London):SPELLING BY DICTATION: Progressive Exercises in English
Orthography, for Schools and Civil Service Examinations. *Sixteenth
Thousand.* 18mo. Cloth, 1/.FLEMING (William, D.D., late Professor of
Moral Philosophy in the University of Glasgow):THE VOCABULARY OF PHILOSOPHY: PSYCHOLOGICAL,
ETHICAL, AND METAPHYSICAL. With Quotations and References for the
Use of Students. Revised and Edited by HENRY CALDERWOOD, LL.D.,
Professor of Moral Philosophy in the University of Edinburgh. *Fourth
Edition, enlarged.* Crown 8vo. Cloth, 10/6.

"The additions by the Editor bear in their clear, concise, vigorous expression, the stamp of his powerful intellect, and thorough command of our language. More than ever, the work is now likely to have a prolonged and useful existence, and to facilitate the researches of those entering upon philosophic studies."—*Weekly Review.*

JAMES (W. Powell, M.A.):

FROM SOURCE TO SEA: or, Gleanings about Rivers from many
Fields. A Chapter in Physical Geography. Cloth elegant, 3/6.

"Excellent reading . . . a book of popular science which deserves an extensive circulation."—*Saturday Review.*

LONDON: EXETER STREET, STRAND.

WORKS BY F. B. JEVONS, M.A.

Now Ready. SECOND EDITION, Revised. Crown 8vo, Cloth, 8s. 6d.

A HISTORY OF GREEK LITERATURE.*From the Earliest Period to the Death of Demosthenes.*

BY FRANK BYRON JEVONS, M.A.,

Tutor in the University of Durham.

Part I.—Epic, Lyric, and the Drama.**Part II.—History, Oratory, and Philosophy.**SECOND EDITION. With Appendix on the *Present State of the Homeric Questions* and Examination-Questions for the Use of Students."It is beyond all question the BEST HISTORY of Greek literature that has hitherto been published."—*Spectator*."An admirable text-book."—*Westminster Review*."Mr. Jevons' work supplies a real want."—*Contemporary Review*."Mr. Jevons' work is distinguished by the Author's THOROUGH ACQUAINTANCE with THE OLD WRITERS, and his DISCRIMINATING USE of the MODERN LITERATURE bearing upon the subject. . . . His great merit lies in his EXCELLENT EXPOSITION of the POLITICAL AND SOCIAL CAUSES concerned in the development of the Literature of Greece."—*Berlin Philologische Wochenschrift*."As a Text-Book, Mr. Jevons' work from its excellence deserves to SERVE AS A MODEL."
--*Deutsche Literaturzeitung*.**THE DEVELOPMENT OF THE ATHENIAN DEMOCRACY.**

Crown 8vo, 1s.

A MANUAL OF GREEK ANTIQUITIES.

FOR THE USE OF STUDENTS.

With Maps and Numerous Illustrations.

*[In Preparation.]***PREHISTORIC ANTIQUITIES OF THE ARYAN PEOPLES,**

Translated from the German of DR. O. SCHRADER by F. B. JEVONS, M.A.

(See page 56, under SCHRADER.)

LONDON: EXETER STREET, STRAND:

McBURNNEY (Isaiah, LL.D.): EXTRACTS
FROM OVID'S METAMORPHOSES. With Notes, Vocabulary, &c.
Adapted for Young Scholars. *Third Edition.* 18mo. Cloth, 1/6.

MENTAL SCIENCE: S. T. COLERIDGE'S
celebrated Essay on METHOD; Archbishop WHATELY'S Treatises on
LOGIC and RHETORIC. *Tenth Edition.* Crown 8vo. Cloth, 5/.

MILLER (W. Galbraith, M.A., LL.B., Lecturer
on Public Law, including Jurisprudence and International Law, in the
University of Glasgow):

THE PHILOSOPHY OF LAW, LECTURES ON. Designed
mainly as an Introduction to the Study of International Law. In 8vo.
Handsome Cloth, 12/. *Now Ready.*

"Mr. MILLER'S 'PHILOSOPHY OF LAW' bears upon it the stamp of a wide culture
and of an easy acquaintanceship with what is best in modern continental speculation.
. . . Interesting and valuable, because suggestive."—*Journal of Jurisprudence.*

WORKS BY WILLIAM RAMSAY, M.A.,

Trinity College, Cambridge, late Professor of Humanity in the University of Glasgow.

A MANUAL OF ROMAN ANTIQUITIES.

For the use of Advanced Students. With Map, 130 Engravings, and very
copious Index. *Fourteenth Edition.* Crown 8vo. Cloth, 8/6.

"Comprises all the results of modern improved scholarship within a moderate com-
pass."—*Athenæum.*

AN ELEMENTARY MANUAL OF

ROMAN ANTIQUITIES. Adapted for Junior Classes. With numerous
Illustrations. *Eighth Edition.* Crown 8vo. Cloth, 4/.

A MANUAL OF LATIN PROSODY,

Illustrated by Copious Examples and Critical Remarks. For the use
of Advanced Students. *Seventh Edition.* Crown 8vo. Cloth, 5/.

"There is no other work on the subject worthy to compete with it."—*Athenæum.*

AN ELEMENTARY MANUAL OF

LATIN PROSODY. Adapted for Junior Classes. Crown 8vo. Cloth, 2s.

Just Published, in Large 8vo, Handsome Cloth, Gilt Top, 21s.

PREHISTORIC ANTIQUITIES OF THE ARYAN PEOPLES,

A Manual of Comparative Philology and the Earliest Culture.
Being the *Sprachvergleichung und Urgeschichte* of

DR. O. SCHRADER.

Translated from the SECOND GERMAN EDITION by

F. B. JEVONS, M.A.

In DR. SCHRADER'S great work is presented to the reader a most able and judicious summary of all recent researches into the Origin and History of those Peoples, Ancient and Modern, to whom has been mainly entrusted the civilisation and culture of the world.

Dr. Schrader's pictures of the Primeval Indo-European Period in all its most important phases—The Animal Kingdom, Cattle, The Plant-World, Agriculture, Computation of Time, Food and Drink, Clothing, Dwellings, Traffic and Trade, The Culture of the Indo-Europeans, and The Prehistoric Monuments of Europe (especially the Swiss Lake-Dwellings), Family and State, Religion, The Original Home—will be found not only of exceeding interest in themselves, but of great value to the Student of History, as throwing light upon later developments.

GENERAL CONTENTS.

- PART I.—HISTORY OF LINGUISTIC PALÆONTOLOGY.
PART II.—RESEARCH BY MEANS OF LANGUAGE AND HISTORY.
PART III.—THE FIRST APPEARANCE OF THE METALS.
PART IV.—THE PRIMEVAL PERIOD.

OPINIONS OF THE PRESS.

"DR. SCHRADER'S GREAT WORK."—*Times*.

"Mr. Jevons has done his work excellently, and Dr. Schrader's book is a model of industry, erudition, patience, and, what is rarest of all in these obscure studies, of moderation and common sense."—*Saturday Review*.

"Able translated by that well-known scholar Mr. Jevons, will be found the best COMPENDIUM of the last thirty years' research into the early history and speech of the Aryan race. . . . INTERESTING FROM BEGINNING TO END."—*Manchester Guardian*.

"The work of the translator has been SINGULARLY WELL PERFORMED."—*Daily Telegraph*.

"In comparison with the First, the Second Edition has gained greatly—not merely in point of size, but of worth. We are convinced that the success which it deserves must attend, in its new form, a book so interesting and STIMULATING."—*Litterarisches Centralblatt*.

LONDON: EXETER STREET, STRAND.

DR SCHRADER'S "PREHISTORIC ANTIQUITIES"—*Continued.*

"When a book like this reaches a Second Edition, we have in the fact a proof that it has, in a happy way, solved the problem how to rouse the sympathy of the reader. . . . Special interest attaches to the section on the ORIGINAL HOME of the Indo-European race."—*Allgemeine Zeitung.*

"A work which in every respect may be described as of CONSPICUOUS EXCELLENCE, and as ensuring to its author a place among the foremost of those engaged in research."—*B(ra)gm(ann)—Literarisches Centralblatt.*

"I must confess that, for long, I have read no work which has roused in me so lively an interest as Dr. SCHRADER'S. In it, the fault to which philologists especially are prone—that of building up the history of civilisation too much in the atmosphere of the study—is avoided in the happiest way. Here all is FRESH, LIVING INSIGHT, AND SOLID WELL-BALANCED REASONING."—*Wilh. Geiger—Deutsche Literaturzeitung.*

"A MOST REMARKABLE BOOK—may be heartily recommended to ALL who take an interest in prehistoric times."—*St(einthal)—Zeitschrift für Völkerverpsychologie und Sprachwissenschaft.*

"One of the BEST WORKS published of late years. . . . Every one who, for any reason whatsoever, is interested in the beginnings of European Civilisation and Indo-European Antiquity, will be obliged to place Dr. SCHRADER'S book on his library shelves. The work addresses itself to the general reader as well as to the learned."—*Gustav Meyer—Philologische Wochenschrift.*

"As the work is INDISPENSABLE alike to the Student of Language, of History, and of Anthropology, every Institution will feel obliged to procure it for its library."—*Zeitschrift für Oesterr. Mittelschulen.*

"The Section on the Names of the Relatives, the position of the Wife, and the primitive FAMILY, is exceptionally significant, since it rests mainly on ethnology. Dr. SCHRADER is a genuine CRITIC, and therefore, with his colossal knowledge, a guide to whom we willingly entrust ourselves."—*Am Ur-Quell, Monatschrift f. Volkskunde.*

"We have only to look into Dr. SCHRADER'S work—its fulness of material, the great caution with which inferences are drawn, its clearness in method and treatment—to be at once won over to the Author and his researches."—*Karl Friedrichs—Deutsche Revue.*

SENIOR (Nassau William, M.A., late Professor of Political Economy in the University of Oxford):

A TREATISE ON POLITICAL ECONOMY: the Science which treats of the Nature, the Production, and the Distribution of Wealth. *Sixth Edition.* Crown 8vo. Cloth. (*Encyclopædia Metropolitana*), 4/.

THOMSON (James): THE SEASONS. With

an Introduction and Notes by ROBERT BELL, Editor of the "Annotated Series of British Poets." *Third Edition.* Fcap 8vo. Cloth, 1/6.

"An admirable introduction to the study of our English classics."

WHATELY (Archbishop): LOGIC—A Treatise on. With Synopsis and Index. (*Encyclopædia Metropolitana*), 3/.

— RHETORIC—A Treatise on. With Synopsis and Index. (*Encyclopædia Metropolitana*), 3/6.

LONDON: EXETER STREET, STRAND.

WORKS IN GENERAL LITERATURE.

BELL (Robert, Editor of the "Annotated Series of British Poets"):

GOLDEN LEAVES FROM THE WORKS OF THE POETS AND PAINTERS. Illustrated by Sixty-four superb Engravings on Steel, after Paintings by DAVID ROBERTS, STANFIELD, LESLIE, STOTHARD, HAYDON, CATTERMOLLE, NASMYTH, Sir THOMAS LAWRENCE, and many others, and engraved in the first style of Art by FINDEN, GREATBACH, LIGHTFOOT, &c. *Second Edition.* 4to. Cloth gilt, 21/.

"'Golden Leaves' is by far the most important book of the season. The Illustrations are really works of art, and the volume does credit to the arts of England."—*Saturday Review.*

"The Poems are selected with taste and judgment."—*Times.*

"The engravings are from drawings by Stothard, Newton, Danby, Leslie, and Turner, and it is needless to say how charming are many of the above here given."—*Athenæum.*

THE WORKS OF WILLIAM COBBETT.

THE ONLY AUTHORISED EDITIONS.

COBBETT (William): **ADVICE TO YOUNG**

Men and (incidentally) to Young Women, in the Middle and Higher Ranks of Life. In a Series of Letters addressed to a Youth, a Bachelor, a Lover, a Husband, a Father, a Citizen, and a Subject. *New Edition.* With admirable Portrait on Steel. Fcap 8vo. Cloth, 2/6.

"Cobbett's great qualities were immense vigour, resource, energy, and courage, joined to a force of understanding, a degree of logical power, and above all a force of expression, which have rarely been equalled. . . . He was the most English of Englishmen."—*Saturday Review.*

"With all his faults, Cobbett's style is a continual refreshment to the lover of 'English undefiled.'"—*Pall Mall Gazette.*

COTTAGE ECONOMY: Containing information relative to the Brewing of Beer, Making of Bread, Keeping of Cows, Pigs, Bees, Poultry, &c.; and relative to other matters deemed useful in conducting the affairs of a Poor Man's Family. *Eighteenth Edition,* revised by the Author's Son. Fcap 8vo. Cloth, 2/6.

LONDON: EXETER STREET, STRAND.

WILLIAM COBBETT'S WORKS—(Continued).

COBBETT (Wm.): EDUCATIONAL WORKS.
(See page 25.)

— A LEGACY TO LABOURERS: An Argument showing the Right of the Poor to Relief from the Land. With a Preface by the Author's Son, JOHN M. COBBETT, late M.P. for Oldham. *New Edition.* Fcap 8vo. Cloth, 1/6.

"The book cannot be too much studied just now."—*Nonconformist.*
"Cobbett was, perhaps, the ablest Political writer England ever produced, and his influence as a Liberal thinker is felt to this day. . . . It is a real treat to read his strong racy language."—*Public Opinion.*

— A LEGACY TO PARSONS: Or, have the Clergy of the Established Church an Equitable Right to Tithes and Church Property? *New Edition.* Fcap 8vo. Cloth, 1/6.

"The most powerful work of the greatest master of political controversy this country has ever produced."—*Pall Mall Gazette.*

GILMER'S INTEREST TABLES: Tables for Calculation of Interest, on any sum, for any number of days, at $\frac{1}{2}$, 1, $1\frac{1}{2}$, 2, $2\frac{1}{2}$, 3, $3\frac{1}{2}$, 4, $4\frac{1}{2}$, 5 and 6 per Cent. By ROBERT GILMER. Corrected and enlarged. *Eleventh Edition.* 12mo. Cloth, 5/.

GRÆME (Elliott): BEETHOVEN: a Memoir. With Portrait, Essay, and Remarks on the Pianoforte Sonatas, with Hints to Students, by DR. FERDINAND HILLER, of Cologne. *Third Edition.* Crown 8vo. Cloth gilt, elegant, 5/.

"This elegant and interesting Memoir. . . . The newest, prettiest, and most readable sketch of the immortal Master of Music."—*Musical Standard.*

"A gracious and pleasant Memorial of the Centenary."—*Spectator.*
"This delightful little book—concise, sympathetic, judicious."—*Manchester Examiner.*

"We can, without reservation, recommend it as the most trustworthy and the pleasantest Memoir of Beethoven published in England."—*Observer.*

"A most readable volume, which ought to find a place in the library of every admirer of the great Tone-Poet."—*Edinburgh Daily Review.*

— A NOVEL WITH TWO HEROES.

Second Edition. In 2 vols. Post 8vo. Cloth, 21/.

"A decided literary success."—*Athenæum.*
"Clever and amusing . . . above the average even of good novels . . . free from sensationalism, but full of interest . . . touches the deeper chords of life . . . delineation of character remarkably good."—*Spectator.*

"Superior in all respects to the common run of novels."—*Daily News.*
"A story of deep interest. . . . The dramatic scenes are powerful almost to painfulness in their intensity."—*Scotsman.*

LONDON: EXETER STREET, STRAND.

THE EMERALD SERIES OF POETS.

Illustrated by Engravings on Steel, after STOTHARD, LESLIE, DAVID ROBERTS, STANFIELD, Sir THOMAS LAWRENCE, CATTERMOLLE, &c. Fcap 8vo. Cloth, gilt.

Particular attention is requested to this very beautiful series. The delicacy of the engravings, the excellence of the typography, and the quaint antique head and tail pieces, render them the most beautiful volumes ever issued from the press of this country, and now, unquestionably, the cheapest of their class.

BYRON (Lord): CHILDE HAROLD'S PILGRIMAGE. With Memoir by Professor SPALDING. Illustrated with Portrait and Engravings on Steel, by GREATBACH, MILLER, LIGHTFOOT, &c., from Paintings by CATTERMOLLE, Sir T. LAWRENCE, H. HOWARD, and STOTHARD. Beautifully printed on toned paper. *Third Thousand.* Cloth, gilt edges, 3/.

CAMPBELL (Thomas): THE PLEASURES OF HOPE. With Introductory Memoir by the Rev. CHARLES ROGERS, LL.D., and several Poems never before published. Illustrated with Portrait and Steel Engravings. *Second Thousand.* Cloth, gilt edges, 3/.

CHATTERTON'S (Thomas) POETICAL WORKS. With an Original Memoir by FREDERICK MARTIN, and Portrait. Beautifully illustrated on Steel, and elegantly printed. *Fourth Thousand.* Cloth, gilt edges, 3/.

GOLDSMITH'S (Oliver) POETICAL WORKS. With Memoir by Professor SPALDING. Exquisitely illustrated with Steel Engravings. *New Edition.* Printed on superior toned paper. *Seventh Thousand.* Cloth, gilt edges, 3/.

Elton Edition, with the Latin Poems. Sixth Thousand.

GRAY'S (Thomas) POETICAL WORKS. With Life by the Rev. JOHN MITFORD, and Essay by the EARL of CARLISLE. With Portrait and numerous Engravings on Steel and Wood. Elegantly printed on toned paper. Cloth, gilt edges, 5/.

HERBERT'S (George) POETICAL WORKS. With Memoir by J. NICHOL, B.A., Oxon, Prof. of English Literature in the University of Glasgow. Edited by CHARLES COWDEN CLARKE. Antique headings to each page. *Second Thousand.* Cloth, gilt edges, 3/.

KEBLE (Rev. John): THE CHRISTIAN YEAR. With Memoir by W. TEMPLE, Portrait, and Eight beautiful Engravings on Steel. *New Edition.*

Cloth, gilt edges, : : : : 5/.

Morocco, elegant, : : : : 10/6.

POE'S (Edgar Allan) COMPLETE POETICAL WORKS. Edited, with Memoir, by JAMES HANNAY. Full-page Illustrations after WEHNERT, WEIR, &c. Toned paper. *Thirteenth Thousand.* Cloth, gilt edges, 3/.

LONDON: EXETER STREET, STRAND.

MACKEY'S FREEMASONRY :

A LEXICON OF FREEMASONRY. Containing a definition of its Communicable Terms, Notices of its History, Traditions, and Antiquities, and an Account of all the Rites and Mysteries of the Ancient World. By ALBERT G. MACKEY, M.D., Secretary-General of the Supreme Council of the U.S., &c. *Eighth Edition*, thoroughly revised with APPENDIX by Michael C. Peck, Prov. Grand Secretary for N. and E. Yorkshire. Handsomely bound in cloth, 6/.

"OF MACKEY'S LEXICON it would be impossible to speak in too high terms ; suffice it to say, that, in our opinion, it ought to be in the hands of every Mason who would thoroughly understand and master our noble Science. . . . No Masonic Lodge or Library should be without a copy of this most useful work."—*Masonic News*.

**HENRY MAYHEW'S CELEBRATED WORK ON
THE STREET-FOLK OF LONDON.****LONDON LABOUR AND THE LONDON**

POOR: A Cyclopaedia of the Condition and Earnings of those that will work and those that cannot work. By HENRY MAYHEW. With many full-page Illustrations from Photographs. In three vols. Demy 8vo. Cloth. Each vol. 4/6.

"Every page of the work is full of valuable information, laid down in so interesting a manner that the reader can never tire."—*Illustrated London News*.

"Mr. Henry Mayhew's famous record of the habits, earnings, and sufferings of the London poor."—*Lloyd's Weekly London Newspaper*.

"This remarkable book, in which Mr. Mayhew gave the better classes their first real insight into the habits, modes of livelihood, and current of thought of the London poor."—*The Patriot*.

The Extra Volume.

LONDON LABOUR AND THE LONDON

POOR: *Those that will not work.* Comprising the Non-workers, by HENRY MAYHEW; Prostitutes, by BRACEBRIDGE HEMYNG; Thieves, by JOHN BINNY; Beggars, by ANDREW HALLIDAY. With an Introductory Essay on the Agencies at Present in Operation in the Metropolis for the Suppression of Crime and Vice, by the Rev. WILLIAM TUCKNISS, B.A., Chaplain to the Society for the Rescue of Young Women and Children. With Illustrations of Scenes and Localities. In one large vol. Royal 8vo. Cloth, 10/6.

"The work is full of interesting matter for the casual reader, while the philanthropist and the philosopher will find details of the greatest import."—*City Press*.

Companion volume to the preceding.

THE CRIMINAL PRISONS OF LONDON,

and Scenes of Prison Life. By HENRY MAYHEW and JOHN BINNY. Illustrated by nearly two hundred Engravings on Wood, principally from Photographs. In one large vol. Imperial 8vo. Cloth, 10/6.

This volume concludes Mr. Henry Mayhew's account of his researches into the crime and poverty of London. The amount of labour of one kind or other, which the whole series of his publications represents, is something almost incalculable.

* * * This celebrated Record of Investigations into the condition of the Poor of the Metropolis, undertaken from philanthropic motives by Mr. HENRY MAYHEW, first gave the wealthier classes of England some idea of the state of Heathenism, Degradation, and Misery in which multitudes of their poorer brethren languished.

LONDON: EXETER STREET, STRAND.

MR. SOUTHGATE'S WORKS.

No one who is in the habit of writing and speaking much on a variety of subjects can afford to dispense with Mr. SOUTHGATE'S WORKS."—*Glasgow News*.

FIRST SERIES—THIRTY-FIFTH EDITION. SECOND SERIES—
NINTH EDITION.

MANY THOUGHTS OF MANY MINDS:

Selections and Quotations from the best Authors. Compiled and
Analytically Arranged by

HENRY SOUTHGATE.

In Square 8vo, elegantly printed on Toned Paper.

Presentation Edition, Cloth and Gold,	Each Vol. 12/6.
Library Edition, Roxburghe,	" 14/.
Ditto, Morocco Antique,	" 21/.

Each Series complete in itself, and sold separately.

"The produce of years of research."—*Examiner*.

"A MAGNIFICENT GIFT-BOOK, appropriate to all times and seasons."—*Freemasons' Magazine*.

"Not so much a book as a library."—*Patriot*.

"Preachers and Public Speakers will find that the work has special uses for them."
Edinburgh Daily Review.

BY THE SAME AUTHOR.

Now Ready, THIRD EDITION.

SUGGESTIVE THOUGHTS ON RELIGIOUS SUBJECTS:

A Dictionary of Quotations and Selected Passages from nearly 1,000 of
the best Writers, Ancient and Modern.

Compiled and Analytically Arranged by HENRY SOUTHGATE. In
Square 8vo, elegantly printed on toned paper. (See page 7.)

THE CHRISTIAN LIFE.

By MRS. HENRY SOUTHGATE.

Thoughts in Prose and Verse from the Best Writers of all Ages. Selected
and Arranged for Every Day in the Year. *Second Edition.*

(See page 7.)

LONDON: EXETER STREET, STRAND.

A BOOK NO FAMILY SHOULD BE WITHOUT.

New Issue of this important Work—Enlarged, in part Re-written, and thoroughly Revised to date.

TWENTY-SIXTH EDITION. Royal 8vo, Handsome Cloth, 1os. 6d.

**A DICTIONARY OF
DOMESTIC MEDICINE AND HOUSEHOLD SURGERY,**

BY

SPENCER THOMSON, M.D., EDIN., L.R.C.S.,

REVISED, AND IN PART RE-WRITTEN, BY THE AUTHOR,

AND BY

JOHN CHARLES STEELE, M.D.,

OF GUY'S HOSPITAL.

With Appendix on the Management of the Sick-room, and many Hints for the Diet and Comfort of Invalids.

In its New Form, DR. SPENCER THOMSON'S "DICTIONARY OF DOMESTIC MEDICINE" fully sustains its reputation as the "Representative Book of the Medical Knowledge and Practice of the Day" applied to Domestic Requirements.

The most recent IMPROVEMENTS in the TREATMENT OF THE SICK—in APPLIANCES for the RELIEF OF PAIN—and in all matters connected with SANITATION, HYGIENE, and the MAINTENANCE of the GENERAL HEALTH—will be found in the New Issue in clear and full detail; the experience of the Editors in the Spheres of Private Practice and of Hospital Treatment respectively, combining to render the Dictionary perhaps the most thoroughly practical work of the kind in the English Language. Many new Engravings have been introduced—improved Diagrams of different parts of the Human Body, and Illustrations of the newest Medical, Surgical, and Sanitary Apparatus.

. *All Directions given in such a form as to be readily and safely followed.*

FROM THE AUTHOR'S PREFATORY ADDRESS.

"Without entering upon that difficult ground which correct professional knowledge and educated judgment can alone permit to be safely trodden, there is a wide and extensive field for exertion, and for usefulness, open to the unprofessional, in the kindly offices of a *True* DOMESTIC MEDICINE, the timely help and solace of a simple HOUSEHOLD SURGERY, or, better still, in the watchful care more generally known as 'SANITARY PRECAUTION,' which tends rather to preserve health than to cure disease. 'The touch of a gentle hand' will not be less gentle because guided by knowledge, nor will the *safe* domestic remedies be less anxiously or carefully administered. Life may be saved, suffering may always be alleviated. Even to the resident in the midst of civilization, the 'KNOWLEDGE IS POWER,' to do good; to the settler and emigrant it is INVALUABLE."

"Dr. Thomson has fully succeeded in conveying to the public a vast amount of useful professional knowledge."—*Dublin Journal of Medical Science.*

"The amount of useful knowledge conveyed in this Work is surprising."—*Medical Times and Gazette.*

"WORTH ITS WEIGHT IN GOLD TO FAMILIES AND THE CLERGY."—*Oxford Herald.*

LONDON: CHARLES GRIFFIN & CO., EXETER STREET, STRAND.

FIRST SERIES—THIRTY-FIFTH EDITION.

SECOND SERIES—NINTH EDITION.

MANY THOUGHTS OF MANY MINDS:

A Treasury of Reference, consisting of Selections from the Writings of the most Celebrated Authors. FIRST AND SECOND SERIES. Compiled and Analytically Arranged
By HENRY SOUTHGATE.

In Square 8vo., elegantly printed on toned paper.

Presentation Edition, Cloth and Gold	12s. 6d. each volume.
Library Edition, Half Bound, Roxburghs	14s. ..
Do., Morocco Antique	21s. ..

Each Series is complete in itself, and sold separately.

"'MANY THOUGHTS,' 8vo., are evidently the produce of years of research."—*Examiner*.

"Many beautiful examples of thought and style are to be found among the selections."—*Leader*.

"There can be little doubt that it is destined to take a high place among books of this class."—*Notes and Queries*.

"A treasure to every reader who may be fortunate enough to possess it. Its personal is like inhaling essences; we have the cream only of the great authors quoted. Here all are seeds or gems."—*English Journal of Education*.

"Mr. Southgate's reading will be found to extend over nearly the whole known field of literature, ancient and modern."—*Gentleman's Magazine*.

"We have no hesitation in pronouncing it one of the most important books of the season. Credit is due to the publishers for the elegance with which the work is got up, and for the extreme beauty and correctness of the typography."—*Morning Chronicle*.

"Of the numerous volumes of the kind, we do not remember having met with one in which the selection was more judicious, or the accumulation of treasures so truly wonderful."—*Morning Herald*.

"The selection of the extracts has been made with taste, judgment, and critical nicety."—*Morning Post*.

"This is a wondrous book, and contains a great many gems of thought."—*Daily News*.

"As a work of reference, it will be an acquisition to any man's library."—*Publishers' Circular*.

"This volume contains more gems of thought, refined sentiments, noble axioms, and extractable sentences, than have ever before been brought together in our language."—*The Field*.

"All that the poet has described of the beautiful in nature and art, all the axioms of experience, the collected wisdom of philosopher and sage, are garnered into one heap of useful and well-arranged instruction and amusement."—*The Era*.

"The collection will prove a mine rich and inexhaustible, to those in search of a quotation."—*Art Journal*.

"Will be found to be worth its weight in gold by literary men."—*The Builder*.

"Every page is laden with the wealth of profoundest thought, and all aglow with the loftiest inspirations of genius."—*Sun*.

"The work of Mr. Southgate far outstrips all others of its kind. To the clergyman, the author, the artist, and the essayist, 'Many Thoughts of Many Minds' cannot fail to render almost invaluable service."—*Edinburgh Mercury*.

"We have no hesitation whatever in describing Mr. Southgate's as the very best book of the class. There is positively nothing of the kind in the language that will bear a moment's comparison with it."—*Manchester Weekly Advertiser*.

"There is no mood in which we can take it up without deriving from it instruction, consolation, and amusement. We heartily thank Mr. Southgate for a book which we shall regard as one of our best friends and companions."—*Cambridge Chronicle*.

"This work possesses the merit of being a MAGNIFICENT GIFT-BOOK, appropriate to all times and seasons; a book calculated to be of use to the scholar, the divine, and the public man."—*Freemason's Magazine*.

"It is not so much a book as a library of quotations."—*Patriot*.

"The quotations abound in that thought which is the mainpring of mental exercise."—*Liverpool Courier*.

"For purposes of opposite quotation, it cannot be surpassed."—*British Times*.

"It is impossible to pick out a single passage in the work which does not, upon the face of it, justify its selection by its intrinsic merit."—*Dorset Chronicle*.

"We are not surprised that a SECOND SERIES of this work should have been called for. Mr. Southgate has the catholic tastes desirable in a good Editor. Preachers and public speakers will find that it has special uses for them."—*Edinburgh Daily Review*.

"The SECOND SERIES fully sustains the deserved reputation of the FIRST."—*John Bull*.

LONDON: CHARLES GRIFFIN & COMPANY.