



LIBRARY  
OF THE  
UNIVERSITY  
OF ILLINOIS

570

IL6c

no. 25-36

cop. 6

NATURAL HISTORY  
SURVEY

NATURAL  
HISTORY SURVEY  
LIBRARY

Digitized by the Internet Archive  
in 2010 with funding from  
University of Illinois Urbana-Champaign



570

Il 6c

no. 35 Cop. 6

U. of I. DUPE.

1948

*Diseases of*  
**Small Grain Crops**  
*in Illinois*

G. H. BOEWE

LIBRARY  
UNIVERSITY OF ILLINOIS  
URBANA

THE LIBRARY OF THE  
JUL 28 1943  
UNIVERSITY OF ILLINOIS

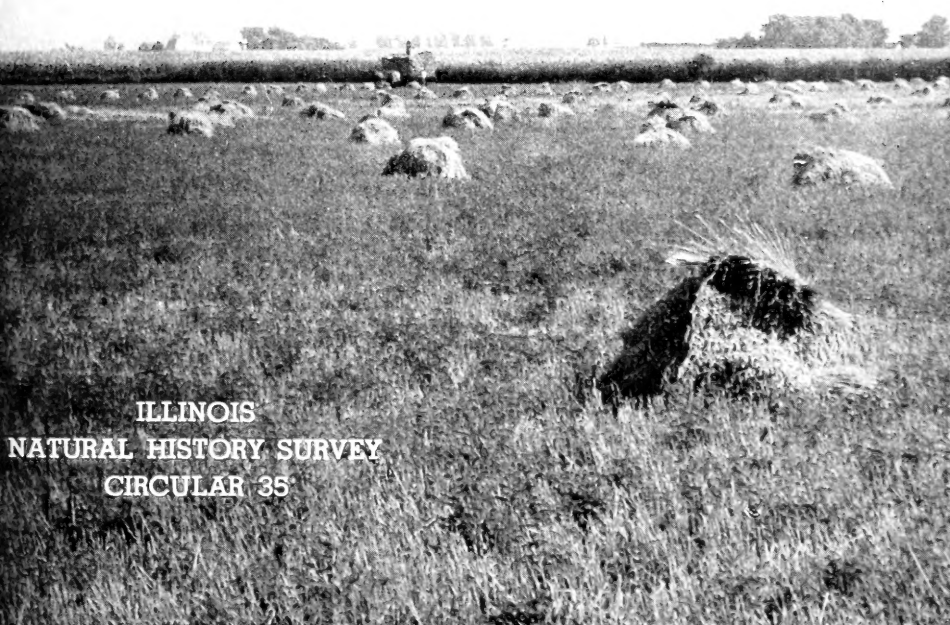

ILLINOIS  
NATURAL HISTORY SURVEY  
CIRCULAR 35

THE UNIVERSITY OF

CHICAGO

LIBRARY

STATE OF ILLINOIS  
Henry Horner, Governor  
DEPARTMENT OF REGISTRATION AND EDUCATION  
John J. Hallihan, Director

*Diseases of*  
**SMALL GRAIN CROPS**  
*in Illinois*

G. H. BOEWE

THE LIBRARY OF THE  
JUL 28 1913  
UNIVERSITY OF ILLINOIS



Printed by Authority of the State of Illinois  
**NATURAL HISTORY SURVEY DIVISION**  
Theodore H. Frison, Chief

STATE OF ILLINOIS  
HENRY HORNER, *Governor*  
DEPARTMENT OF REGISTRATION AND EDUCATION  
JOHN J. HALLIHAN, *Director*

BOARD OF NATURAL RESOURCES AND CONSERVATION

JOHN J. HALLIHAN, *Chairman*

WILLIAM TRELEASE, D.Sc., LL.D., *Biology*      WILLIAM A. NOYES, Ph.D., LL.D.,  
HENRY C. COWLES, Ph.D., D.Sc., *Forestry*      Chem.D., D.Sc., *Chemistry*  
L. R. HOWSON, B.S.C.E., C.E., *Engineering*      EDSON S. BASTIN, Ph.D., *Geology*  
ARTHUR CUTTS WILLARD, D.Eng., LL.D.,  
*President of the University of Illinois*

NATURAL HISTORY SURVEY DIVISION  
Urbana, Illinois

SCIENTIFIC AND TECHNICAL STAFF

THEODORE H. FRISON, Ph.D., *Chief*

SECTION OF ECONOMIC ENTOMOLOGY

W. P. FLINT, B.S., *Chief Entomologist*  
C. C. COMPTON, M.S., *Associate Entomologist*  
M. D. FARRAR, Ph.D., *Research Entomologist*  
J. H. BIGGER, B.S., *Associate Entomologist*  
S. C. CHANDLER, B.S., *Southern Field Entomologist*  
L. H. SHROPSHIRE, M.S., *Northern Field Entomologist*  
W. E. MCCAULEY, M.S., *Assistant Entomologist*  
C. J. WEINMAN, M.A., *Assistant Entomologist*  
C. W. KEARNS, Ph.D., *Research Fellow in Entomology*  
ARTHUR E. RITCHER, B.A., *Research Fellow in Entomology*  
R. C. RENDTORFF, M.S., *Research Fellow in Entomology*  
K. L. KNIGHT, M.S., *Research Fellow in Entomology*

SECTION OF INSECT SURVEY

H. H. ROSS, Ph.D., *Systematic Entomologist*  
CARL O. MOHR, Ph.D., *Associate Entomologist, Artist*  
B. D. BURKS, Ph.D., *Assistant Entomologist*  
G. T. RIEGEL, B.S., *Assistant Entomologist*  
KATHRYN M. SOMMERMAN, B.S., *Artist, Assistant Entomologist*

SECTION OF FORESTRY

JAMES E. DAVIS, M.F., *Extension Forester*  
LEE E. YEAGER, Ph.D., *Forester*

SECTION OF AQUATIC BIOLOGY

DAVID H. THOMPSON, Ph.D., *Zoologist*  
GEORGE W. BENNETT, Ph.D., *Limnologist*  
D. F. HANSEN, Ph.D., *Assistant Zoologist*  
C. L. SCHLOEMER, Ph.D., *Assistant Aquatic Biologist*

SECTION OF GAME RESEARCH AND MANAGEMENT

RALPH E. YEATTER, Ph.D., *Game Specialist*  
C. S. SPOONER, JR., M.S., *Junior Biologist*

SECTION OF WILDLIFE EXPERIMENTAL AREAS

ARTHUR S. HAWKINS, M.S., *Game Technician*  
F. C. BELLROSE, JR., B.S., *Assistant Game Technician*

COOPERATIVE WILDLIFE RESTORATION PROGRAM

(*State Department of Conservation and U. S. Biological Survey*)  
H. G. ANDERSON, M.A., *Junior Biologist*  
LOUIS G. BROWN, B.S., *Junior Biologist*  
R. E. HESSELSCHWERDT, B.A., *Junior Biologist*

SECTION OF APPLIED BOTANY AND PLANT PATHOLOGY

L. R. TEHON, Ph.D., *Botanist*  
D. B. CREAGER, Ph.D., *Research Pathologist*  
J. C. CARTER, Ph.D., *Assistant Botanist*  
G. H. BOEWE, M.S., *Field Botanist*

SECTION OF PUBLICATIONS

JAMES S. AYARS, B.S., *Editor*

*This paper is a contribution from the Section of Applied Botany and Plant Pathology*



570  
Il6c  
no. 35  
cop. 6

## Contents

	PAGE
I. Nature of Cereal Diseases.....	1
History of plant diseases, 2; Kinds of plant diseases, 2; Fungi, bacteria and viruses, 3; Dissemination of diseases, 7; Damage done by plant diseases, 8; Important cereal diseases and their causes, 10; How to recognize diseased plants, 11; How to diagnose a plant disease, 12.	
II. Wheat Diseases.....	14
Diagnostic Key for Wheat Diseases.....	15
Leaf Rust.....	17
Black Stem Rust.....	20
Speckled Leaf Blotch.....	25
Scab.....	28
Anthracnose.....	31
Helminthosporium Disease.....	33
Stinking Smut.....	36
Loose Smut.....	38
Flag Smut.....	40
Basal Glume Rot.....	43
Black Chaff.....	45
Glume Blotch.....	47
Ergot.....	50
Powdery Mildew.....	50
Mosaic.....	52
Take-All.....	55
Nematode Disease.....	56
III. Oats Diseases.....	58
Diagnostic Key for Oats Diseases.....	59
Crown Rust.....	60
Black Stem Rust.....	62
Halo Blight.....	63
Helminthosporium Leaf Spot.....	65
Scab.....	67
Anthracnose.....	68
Loose Smut.....	69
Covered Smut.....	71
Blast.....	73
Ergot.....	74
Powdery Mildew.....	74
IV. Barley Diseases.....	75
Diagnostic Key for Barley Diseases.....	76
Leaf Rust.....	77
Black Stem Rust.....	78
Stripe.....	79
Bacterial Blight.....	82
Spot Blotch.....	84
Net Blotch.....	85

28443 div. no. 35, 1939

	PAGE
Non-Parasitic Brown Spot.....	87
Scab.....	88
Anthracnose.....	90
Loose Smut.....	90
Covered Smut.....	92
Powdery Mildew.....	94
Ergot.....	95
V. Rye Diseases.....	96
Diagnostic Key for Rye Diseases.....	96
Leaf Rust.....	98
Black Stem Rust.....	99
Scald.....	100
Bacterial Blight.....	101
Scab.....	102
Anthracnose.....	103
Helminthosporium Disease.....	103
Stem Smut.....	103
Loose Smut.....	105
Ergot.....	106
Powdery Mildew.....	107
Mosaic.....	108
Nematode Disease.....	109
VI. Cereal Disease Control.....	110
Good farm practices, 111: Sanitation, 111; Rotation of crops, 112; Resistant varieties, 112; Cultural methods, 113; Good seed, 114; Fungicides on the growing plant, 116.	
Regulation, 116: Inspection, 117; Quarantine, 117; Eradication, 117.	
Seed treatment, 118: Seed treatment suggestions, 118; Machines for applying dust treatments, 120; Copper sulfate treatment, 121; Copper carbonate treatment, 122; Formaldehyde treatments, 123; Hot water treatments, 126; Organic mercury treatments, 128.	

---

*Photographs by Ray R. Hamm, unless otherwise credited; graphs by Ronald E. Favreau; figure 1 by Kathryn M. Sommerman.*

## *Natural History Survey Publications of Value to Illinois Farmers*

- Peach Yellows in Illinois. By L. R. Tehon and G. L. Stout. Illinois Natural History Survey Circular 21. 24 pages, 9 figures. November, 1929.
- Windbreaks for Illinois Farmsteads. By J. E. Davis. Illinois Natural History Survey Circular 29. 18 Pages, 12 figures. April, 1938.
- Outwitting Termites in Illinois. By W. E. McCauley and W. P. Flint. Illinois Natural History Survey Circular 30. 19 pages, 19 figures. June, 1938.
- The Peach Tree Borers of Illinois. By S. C. Chandler. Illinois Natural History Survey Circular 31. 36 pages, 22 figures. January, 1939.
- Controlling Peach Insects in Illinois. By S. C. Chandler and W. P. Flint. Illinois Natural History Survey Circular 33. 40 pages, 32 figures. August, 1939.
- Rout the Weeds! By L. R. Tehon. Illinois Natural History Survey Circular 34. 47 pages, 13 figures. August, 1939.
- The Effect of Petroleum-Oil Sprays on Insects and Plants. Illinois Natural History Survey Bulletin 21, Article 1. 32 pages, 21 figures. November, 1936.
- 

## *Publications of General Interest*

- Fieldbook of Illinois Wild Flowers. By the staff. Illinois Natural History Survey Manual 1. 406 pages, 349 figures, color frontispiece. Descriptions of 650 species. March, 1936. \$1.50.
- Fieldbook of Illinois Land Snails. By Frank Collins Baker. Illinois Natural History Survey Manual 2. 166 pages, 170 figures, 8 plates, color frontispiece. Descriptions of 122 species. August, 1939. \$1.00.
- Pleasure With Plants. By L. R. Tehon. Illinois Natural History Survey Circular 32. 32 pages, 9 figures, frontispiece. April, 1939.
- Lake Management Reports 3. Lincoln Lakes Near Lincoln, Illinois. By David H. Thompson and George W. Bennett. Illinois Natural History Survey Biological Notes No. 11. 24 pages, 8 figures. August, 1939.
- 

Address orders and correspondence to the Chief

**ILLINOIS STATE NATURAL HISTORY SURVEY**

Natural History Bldg., Urbana, Ill.

Payment in the form of U. S. Post Office money order made out to  
State Treasurer of Illinois, Springfield, Illinois,  
must accompany requests for those publications on which a price is set.

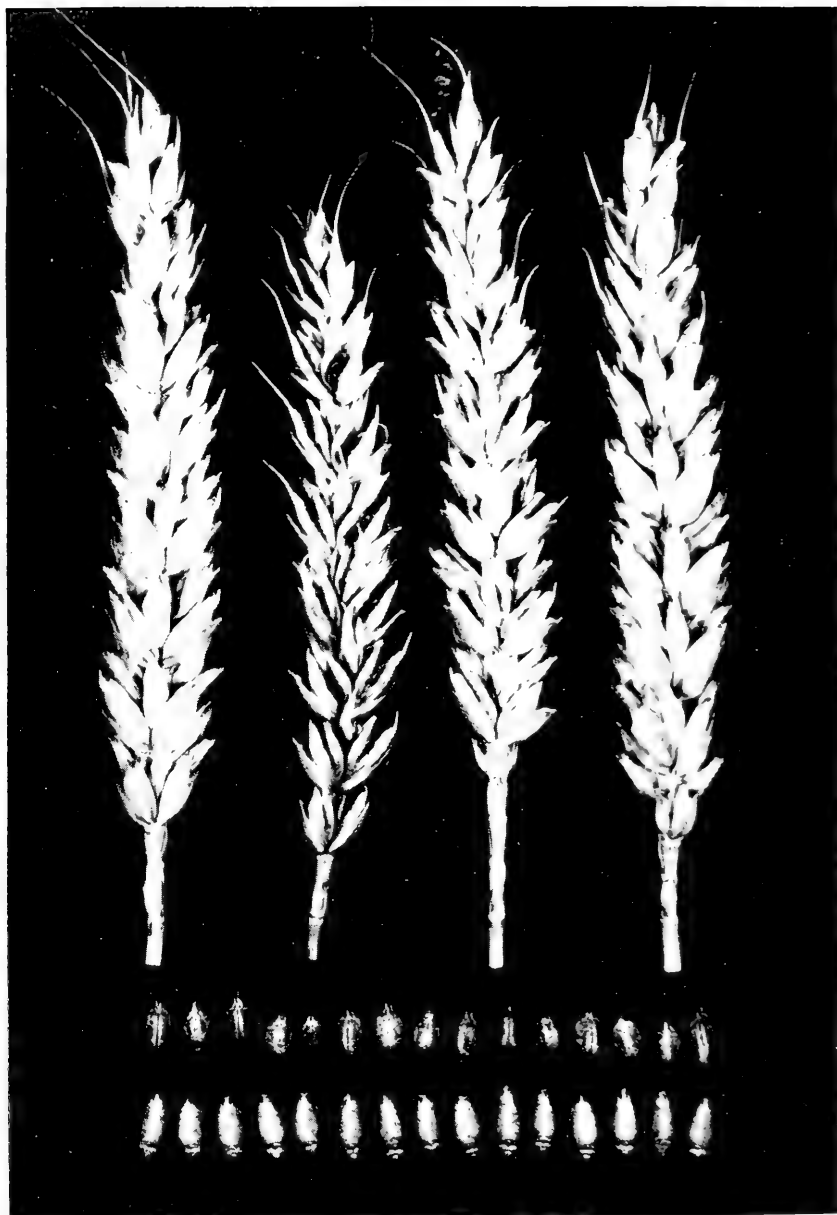

Stinking smut of wheat. The two heads in the center are infected; those to the right and left of them are normal. Kernels in the lower row are normal; those in the upper row are infected and often are called smut balls. Harvested grain containing even a small percentage of smut balls is subject to price dockage.

# I

## *Nature of Cereal Diseases*

**S**MALL grains, from an economic standpoint, are among the most important crops raised on Illinois farms. They occupy an essential place in the cropping system and, besides having a market value, they provide food for animals, serve as pasture and bedding, and sometimes as green manure crops.

All of the small grains, the most important of which in Illinois are wheat, oats, barley and rye, are susceptible to attack by diseases. Since 1921 the Illinois Natural History Survey has been engaged in surveying the grain fields of the state to ascertain what diseases are present and to determine the relative prevalence and intensity of attack of the epidemic diseases. That accurate data might be obtained, counts have been taken yearly in representative fields and, in case of doubt as to the identity of any disease, samples have been given laboratory examination.

As a result of these surveys, the economic importance of the diseases of cereal crops has been defined more clearly than in the past. These diseases affect the farmer's income not only by reducing yields but also by reducing the quality and consequently the market value of the grain harvested. Data collected annually over a period of 10 years show that in Illinois leaf rust alone, which is the most important disease of wheat, attacks on an average 93.9 per cent of the wheat plants and destroys 14.98 per cent of the wheat leaf area. The average loss per year from this one disease, indicated by estimates for 20 consecutive years, is \$1,616,000.

With such losses incurred annually from this and other diseases, it is important that the farmer be able to recognize and combat the diseases that are most prevalent and destructive.

The more conspicuous diseases, such as rusts and smuts, are well known to many producers of grain; but there are other important diseases, which attack roots or stems or destroy part of the leaf area, that are not so generally known. A detailed description of the cereal diseases that have been found important in Illinois, and of suitable control methods, is presented in the following pages. Diseases are listed under the cereals they attack. If a disease attacks more than one crop, it is described most fully in relation to the crop on which it is most important. Cross

references are given in every case, so that a reader may turn to the full description. A key based on host plant symptoms has been inserted at the beginning of each section devoted to a grain, to enable the reader to identify diseases in which he may be interested.

## HISTORY OF PLANT DISEASES

Plant diseases have occurred, and some have been recognized, since the earliest days of man's civilization. Records of blights and mildews are found in early historic and religious writings. Rusts were recognized and mentioned by Aristotle as early as 350 B. C. But ancient peoples knew little of the physiological behavior of plants, and maladies were regarded by them with superstition and were often thought of as plagues sent as punishment by some divine power. Such ideas persisted through the ancient eras and into the Dark Ages.

Modern knowledge of plant diseases may be said to date from 1853, with the publication of the brilliant studies of the German scientist, Anton de Bary. Until the beginning of the present century, German scientists held the most prominent place in the development of plant pathology. In 1873, the first teaching of plant pathology in America was done at the University of Illinois, by Professor J. T. Burrill. With the organization in 1885 of a section of mycology in the division of botany of the U. S. Department of Agriculture and the organization in 1887 of the state agricultural experiment stations under the Hatch Act, a broad foundation was laid for the study of plant diseases in the United States. Since that time much has been learned about causes and methods of control for many plant diseases, and because of its contributions the United States has attained a preeminent place in the field of plant pathology.

## KINDS OF PLANT DISEASES

In the process of growth, plants may be subjected to physiological disturbances, to attack by parasites or to virus infections. All of these interfere with normal functioning or development, and the abnormal conditions that result are known as diseases. Disease may be localized in a definite part of a plant, such as the roots, stem, leaf, flower or grain, or the entire plant may be affected.

According to cause, diseases of plants may be divided into the following three groups.

**Parasitic Diseases.**—Plants are subject to attack by animals and by other plants which depend for their living upon the plant they attack. All animals that depend in any measure upon plants for food may be regarded as in some degree parasitic. Among those that injure useful plants are gophers and mice, insects, snails and nematodes. Parasitic plants include seed-bearing plants such as dodder, mistletoe and broom rape, and non-seed-bearing plants such as fungi, algae, slime molds and bacteria. Attack by fungi and bacteria, which generally live internally in their host plants, usually results in the production of disease.

**Non-Parasitic Diseases.**—Non-parasitic diseases may be due to a number of causes, of which the most important are improper environmental conditions, lack of certain resistant factors in the plant and harmful mechanical influences. Proper soil conditions, temperature, rainfall, light and air are essential for normal development. Lack of the correct kind or amount of one or more of these factors, or a disturbance in their balance, may lead to the development of disease as certainly as does attack by parasites. Resistant varieties have been developed which may attain normal growth in spite of some adverse environmental factors; lack of resistant factors tends to make plants susceptible to disease. Mechanical injuries to plants may produce disease and may also open avenues for infection by parasites.

**Virus Diseases.**—Virus diseases are systemic infections which invade the entire body of a plant. They result in various kinds of abnormalities, the commonest of which, a mottling of leaves with light and dark green, is the only type known on cereals. But other kinds of plants show other effects, such as the bushy growth of asters affected by aster yellows and the willowy growth of peach trees infected with peach yellows. Leaf mottling is commonly called mosaic.

## FUNGI, BACTERIA AND VIRUSES

**Fungi.**—Fungi are members of a primitive group of plants. They do not contain green coloring matter and so are unable to produce their own food. They may be divided into two classes: parasitic, depending on living plant tissue to maintain their existence, and saprophytic, living on dead plant or animal material. Most parasitic fungi are detrimental to man, but those that

are saprophytic may be beneficial by aiding in the disintegration of dead plant and animal material and thus maintaining the fertility of the soil.

Fungi, though very much smaller and simpler, are comparable in some ways to green plants, fig. 1. The part of the fungus which corresponds to the root, stem and leaves of a green plant consists of threads or filaments called hyphae. Hyphae usually are divided into cells by cross walls, and they usually branch and rebranch, forming a network of filaments. The mass of hyphae which makes up this network is called mycelium.

In a fungus, as in seed plants, a vegetative period concerned with growth and the accumulation of food precedes the reproductive phase. The vegetative part of a parasitic fungus, the mycelium, usually grows within the host plant's tissue and is not often visible on the surface; but it may be superficial, establishing contact with the interior of the plant by means of small suckers which it pushes into the outer cell layer of its host.

It is the reproductive structure of the fungus, corresponding to the fruit and seed of flowering plants, that we most commonly see. Such a "fruiting" body is usually dark and large enough to be seen with the naked eye. It may be produced on the surface of the host, but usually it is formed within its tissue and breaks through to the surface by the time the spores it contains, which function somewhat like seeds, are mature and ready to be discharged. A spore differs from a seed in that it does not contain a tiny embryo or young plant. It is very small, often being made up of only one cell, but it contains the living material by which a fungus is reproduced. If a spore has more than one cell, each cell usually has the power of producing a new fungus.

Different kinds of fungi produce their spores in different ways. Some send up stalks from the vegetative part, on which the spores are produced singly, in strings like beads or in clusters. In the last case, the spores may be inclosed by a membrane or may be exposed. Other fungi produce their spores on small stalks inclosed in flask-shaped or spherical bodies, in more or less

---

Fig. 1 illustrates the life history of wheat compared stage by stage with life histories of four important fungous parasites of grains. The wheat seed and the overwintering spores, pictured across the top of the page, germinate and give rise to primary structures such as seedlings and germ tubes, in the second row. Growth forms the vegetative stage, in the third row, which in the case of the fungi constitutes the period of infection. Finally the wheat plant and the fungi mature, as in the fourth row, producing seed or overwintering spores. Details of individual life histories are given in the text.



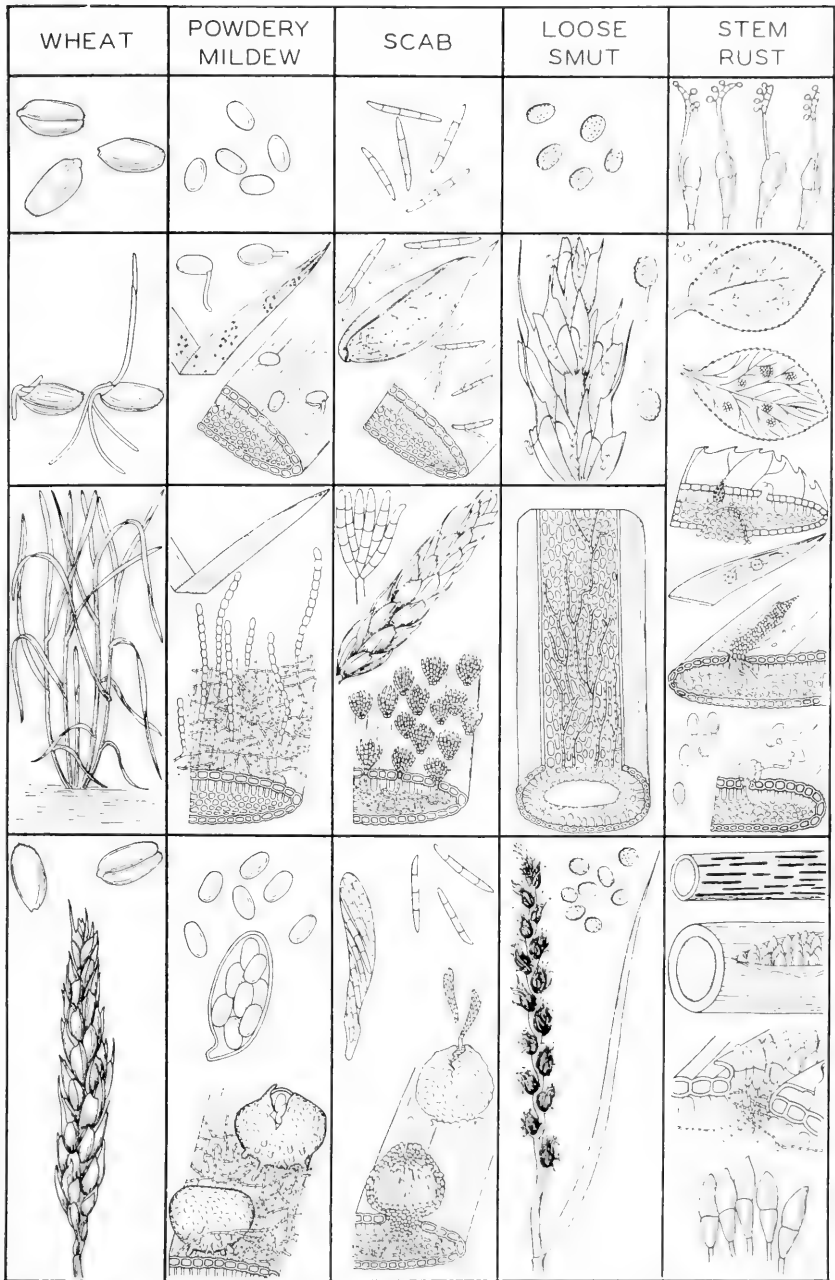

Fig. 1.—Four typical life histories of fungous parasites of cereals compared with the life history of wheat.

flattened "cups" or in small club-shaped sacks which are produced inside spherical bodies. As a rule spores are so very small that they are invisible without a microscope, but they are produced in immense numbers. It has been estimated that there are at least 1 million, possibly as many as 8 million, spores in one smut ball of stinking smut.

Some fungi produce only one kind of spore, and this often is called a summer spore. As seeds of higher plants vary in their length of viability, so do spores. Many summer spores are unable to withstand winter conditions, and many fungi therefore develop a second type, called the resting spore, which serves to carry the fungus through the winter.

Newly formed spores may remain attached for a short time to the structure on which they are borne, but soon they are discharged and carried away. Only a very small percentage of the spores that are produced ever cause infection, because most of them alight in situations that do not furnish the food material and moisture necessary for their development. Some fungi find suitable food material in only one host plant, but others not so specific in their requirements thrive on two or more host plants. In some instances the host plants of disease-producing fungi are unrelated, as is true of barberry and wheat in the case of black stem rust. Weeds as well as cultivated plants may serve as hosts.

Moisture is necessary both for spore germination and for enabling the young fungus to enter its host. Usually when the fungus has once entered its host it is able to continue its existence, for there it finds ideal moisture conditions and comes in close contact with the source of its food, which it absorbs directly from the cells of its host. However, many spores die because they fall on unsuitable hosts, from which they are unable to obtain food for growth, or because they do not find sufficient moisture to enable them to germinate or because after germinating they dry up before they have a chance to enter the host.

**Bacteria.**—Bacteria are the very minute one-celled plants commonly called germs. They are almost inconceivably small, measuring as an average only about  $\frac{1}{12,700}$  inch in length. It would take 793 of them placed end to end to measure 1 inch. There are three general forms or shapes of bacteria, namely, spheres, rods and spirals. Only the second causes disease in plants.

Bacteria have the simplest kind of life cycle. A mature

bacterium divides into two nearly equal parts, and each part grows to the size of the original and repeats the division if conditions are favorable. The rate of division and growth depends upon such environmental factors as food available, temperature and presence or absence of poisonous substances, but under favorable conditions a life cycle is completed in 30 to 40 minutes. While certain bacteria form spores which carry them through periods of adverse conditions, none of the bacteria that cause plant diseases are known to have this adaptation.

**Viruses.**—The infectious principle that causes mosaic diseases is called a virus. What it is, no one knows. It has some of the characteristics of a germ, but it is so small that it cannot be seen with even the most powerful microscopes. Nevertheless, viruses can be transferred from diseased to healthy plants, after which the healthy plants become diseased. Insects are the chief carriers, but man is an important agent, also, in spreading certain virus diseases. Some viruses can be transmitted by seed; others are thought to reside in the soil.

## DISSEMINATION OF DISEASES

Bacteria, fungi and viruses are carried from place to place by various means. In the case of bacteria, the entire individual is transferred, while generally only the spores of fungi are moved. In what state viruses are carried, no one knows.

The most important disseminating agents for fungi and bacteria are wind, water, insects, animals and man. Bacteria and spores of fungi have been known to be carried long distances, in some cases hundreds of miles, and retain their viability. Strong winds may carry fragments of infected plant debris.

Water may aid in disease dissemination in several ways. Plant material is carried for long distances down rivers, around the shores of lakes or along the ocean shores. Accompanying this debris are bacteria and fungi which, when the material drifts to shore, may become established on crops.

Rain is often instrumental in washing bacteria and fungous spores from one plant to another; however, this means of distribution is limited in its importance. Running water may carry infected soil and plant debris from one field to another and thus spread both soil-borne and air-borne diseases.

Insects play a very important part in spreading parasites and viruses. The hairy bodies of insects are well adapted to

picking up from diseased plants spores and bacteria which are dropped as the insects travel from plant to plant. The mouth parts of sucking insects feeding upon diseased plants become contaminated with bacteria or spores, which are subsequently deposited on healthy plants. The majority of viruses are transmitted by insects, and some of them can be transmitted in no other way.

Animals also may aid in the distribution of plant diseases. As they move through the fields, they may rub off on healthy plants the spores they have picked up on their coats from diseased plants.

There are many instances of the introduction and spread of diseases by man. Seeds, bulbs, nursery stock and other plant materials shipped from country to country, state to state or farm to farm occasionally carry invisible infections to new localities. Infected plant material used as bedding or packing, when shipped from one place to another, may disseminate disease-producing organisms.

As an illustration of the local distribution of disease through man's activities, we may cite a case observed in Illinois of a certain farmer and his four neighbors. In 1932 this farmer had stinking smut in his wheat. His neighbors had clean fields. At harvest time, the machine threshed the first farmer's wheat and then went on to his neighbors. Each farmer used wheat from his crop for seed, without treating it before planting. The next year the four neighbors found smut in varying amounts in their fields. When the first farmer's wheat had been threshed, spores of the smut fungus were left in the machine and were later mixed in his neighbors' wheat, the greatest number of spores being mixed with the wheat of the first neighbor to use the machine and the smallest number with that of the neighbor threshing last. Other implements, such as rackwagons, drills and cultivating tools, sometimes carry infection from field to field or farm to farm in somewhat the same way.

## DAMAGE DONE BY PLANT DISEASES

Diseases cause very definite losses by decreasing stands, lowering yields and impairing the quality of grains, fig 2. Less definitely determinable but very important are the attendant increases in cost of production, lowering of market values and, in extreme cases, decreases in land values.

The yield expected from an otherwise normal cereal crop may be greatly lessened by the presence of disease. Some diseases, by killing the plants they infect, cause poor stands.

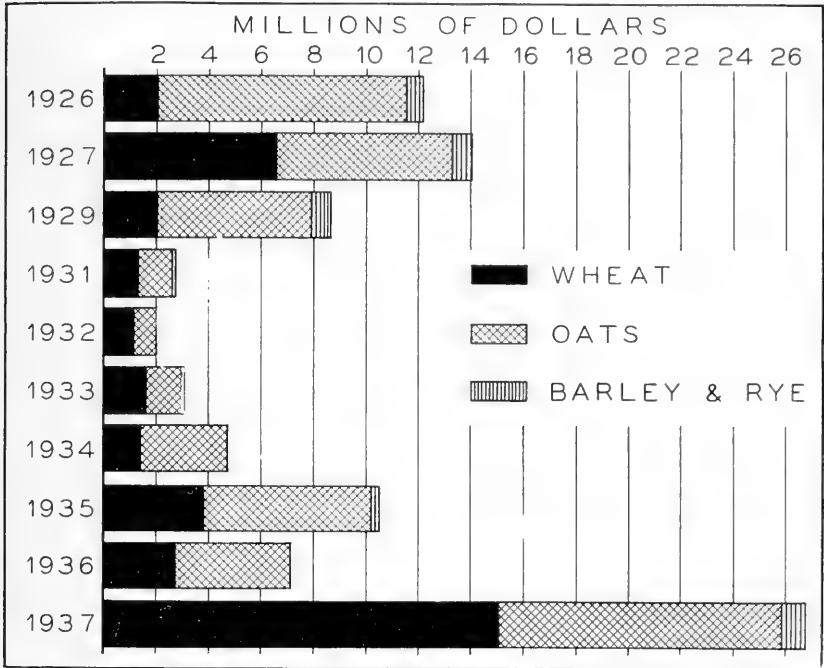

Fig. 2.—Money value of the reductions, due to disease, in cereal crop yields in Illinois, based on the estimates available for the period 1926-1937.

Others, that attack only portions of the plants, such as roots, stems or leaf tissues, so weaken the plants that they produce less grain. Plants with roots attacked by rot fungi or with a portion of the leaf tissue destroyed usually produce grain of inferior quality, which brings a lower price than first quality grain. If this poor grain is kept for seed, a reduced stand, poor yield and inferior grain may be expected the following season. A reduction in yield, together with an increase in the amount of seed required to produce a good stand, at once increases the cost of production and decreases the net returns a farmer may expect from his grain crop. All of these factors may combine eventually to lower the value of the land, especially if the principal damage is due to a disease which remains viable in the soil from year to year.

## IMPORTANT CEREAL DISEASES AND THEIR CAUSES

Diseases of crop plants noticed by observant persons receive names that are descriptive of their appearance and, by long and general usage, these common names come to have definite and universal significance. Scientific investigation eventually reveals the cause of the disease, and if the cause is a living organism it is named by the scientist in Latin, so that the meaning of the name may be understood throughout the world. The Latin, or scientific, names of the parasites that cause the diseases of cereal crops discussed in succeeding pages are given below, with the authorities responsible for them.

1. Smut diseases:
  - Loose smut of wheat and rye.....*Ustilago Tritici* (Pers.) Rostr.
  - Loose smut of oats.....*Ustilago Avenae* (Pers.) Jens.
  - Loose smut of barley.....*Ustilago nuda* (Jens.) Kell. & Sw.
  - Covered smut of oats.....*Ustilago laevis* (Kell. & Sw.) Magn.
  - Covered smut of barley.....*Ustilago Hordei* (Pers.) Kell. & Sw.
  - Stinking smut of wheat.....*Tilletia laevis* Kuehn
  - Flag smut of wheat.....*Urocystis Tritici* Koern.
  - Stem smut of rye.....*Urocystis occulta* (Wallr.) Rabenh.
2. Rust diseases:
  - Leaf rust of wheat.....*Puccinia rubigo-vera* (DC.) Wint.,  
var. *triticea* (Erikss. & Henn.)  
Carl.
  - Leaf rust of oats.....*Puccinia coronata* Cda.
  - Leaf rust of barley.....*Puccinia anomala* Rostr.
  - Leaf rust of rye.....*Puccinia rubigo-vera* (DC.) Wint.,  
var. *Secalis* (Erikss.) Carl.
  - Black stem rust of wheat, oats,  
barley and rye.....*Puccinia graminis* Pers.
3. Leaf diseases:
  - Bacterial blight of barley.....*Bacterium translucens* Jones, John-  
son & Reddy
  - Bacterial blight of rye.....*Bacterium translucens secalis* Red-  
dy, Godkin & Johnson
  - Barley stripe.....*Helminthosporium gramineum*  
Rabenh.
  - Halo blight of oats.....*Bacterium coronafaciens* Elliott
  - Helminthosporium leaf spot of oats..*Helminthosporium Avenae* Eidam
  - Net blotch of barley.....*Pyrenophora teres* (Died.) Drechs.
  - Powdery mildew of all small grains..*Erysiphe graminis* DC.
  - Scald of rye.....*Rhynchosporium Secalis* (Oud.)  
Davis
  - Speckled leaf blotch of wheat.....*Septoria Tritici* Desm.
  - Spot blotch of barley.....*Helminthosporium sativum* Pam.
4. Head diseases:
  - Basal glume rot of wheat.....*Bacterium atrofaciens* McC.
  - Black chaff of wheat.....*Bacterium translucens* Jones, John-  
son & Reddy, var. *undulosum* Smith,  
Jones & Reddy

- Ergot, of rye and other cereals....*Claviceps purpurea* (Fr.) Tul.  
 Glume blotch of wheat.....*Septoria nodorum* Berk.  
 Scab, of all small grains.....*Gibberella Saubinetii* (Mont.) Sacc.
5. Stem diseases:  
 Anthracnose.....*Colletotrichum cereale* Manns  
 Nematode disease.....*Tylenchus tritici* (Stein.) Bast.
6. Root rots:  
 Take-all of wheat.....*Ophiobolus Cariceti* (B. & Br.)  
   Sacc.  
 Foot rot of wheat and other cereals..*Helminthosporium sativum* Pam.

## HOW TO RECOGNIZE DISEASED PLANTS

Because of the wide prevalence of plant diseases and the great losses they cause, it is important to be able to recognize and deal with them. Plants that are diseased usually exhibit abnormalities, and from these it is frequently possible to determine what disease is present. The following signs, or symptoms, occurring singly or in varying combinations, indicate the presence of disease.

1. When the **entire plant** is affected there is:
  - a. Premature dying or ripening, usually accompanied by whitish or reddish-brown discoloration; or
  - b. Dwarfing, often accompanied by a sickly yellow rather than a healthy green color; or
  - c. Extra growth, usually elongation of stems, with poor color, small leaves and weak stems.
2. When the **head** is affected, there is:
  - a. Pale or blue-green color and distended chaff; or
  - b. Pinkish or reddish color on the spikelets; or
  - c. Premature ripening of spikelets; or
  - d. Abnormal roughening of grain; or
  - e. Failure to head; or
  - f. Grain replaced by:
    - (1) Large purplish bodies (ergot); or
    - (2) Short, thick galls, easily crushed, with fishy odor (stinking smut); or
    - (3) Short, thick galls, hard, with no odor (nematode); or
    - (4) Black powdery masses covered by delicate membranes (covered smut); or
    - (5) Black, powdery masses not covered by delicate membranes (loose smut); or
    - (6) Loose black masses dispersed before harvest (loose smut).
3. When the **leaves** are affected, there may be:
  - a. Water-soaked, sunken spots (bacterial spots); or
  - b. Mottling or streaking with yellow (mosaics); or
  - c. Brownish or reddish spots, usually dead (leaf spots); or
  - d. Whitish-gray mold on surface (powdery mildew); or
  - e. Brown longitudinal stripes, along which leaf splits (barley stripe); or
  - f. Stripes of various colors, not accompanied by splitting; or
  - g. Pustules on leaves (rusts).

4. When the **stem** is affected, there may be:
  - a. Black or purplish blotches, especially at joints (anthracnose, etc.);  
or
  - b. Small elevations, red or black pustules (rusts); or
  - c. Rot at ground line (seedling rot, damping-off).
5. When the **roots** are affected, there may be:
  - a. Reddish-brown or black spots on the roots; or
  - b. Rotted, brittle roots (root rots).

## HOW TO DIAGNOSE A PLANT DISEASE

When signs such as those listed above have been observed, the next step is to determine the specific disease that is present. To accomplish this it is necessary to analyze the symptoms in a logical manner, in much the same way as a physician diagnoses his patient's ills. An analysis of the symptoms of disease is given for each crop, on later pages, in an outline form called a diagnostic key.

Before an attempt is made to use such a key, the outstanding symptoms exhibited by diseased plants should be carefully observed. It is desirable that a number of plants be examined and that the symptoms present in the greatest degree be noted. Because individual plants exhibit variations in symptoms, if only one or two plants are observed, incorrect diagnosis may result.

In most cases it will be found that only one part of the plant has been affected—the head, leaves or some other part. For this reason, the key stresses first the part of the plant affected and refers by number to subsequent sections of the key, in which further analyses are given. In each such section, just two items are listed. Both of these should be considered and the outstanding symptoms previously noted kept in mind in making a decision as to which one applies to the case in hand. An item which describes only part of the symptoms refers by number to a section farther along in the key. But an item which, with the items above, completes the description of the symptoms gives the name of the disease at the end of the line. Analysis of symptoms thus proceeds step by step through succeeding sections of the key until the identity of the disease has been worked out.

The following is an example of the way in which a key is used in diagnosing diseases.

In a well-grown wheat field, it might be noticed that the plants in a certain area seem less healthy than those in other parts of the field. A closer examination of these plants may reveal the chief sign of disease to be a spotting of the leaves.



The spots, it is found, are circular to long oval in shape and are covered by a grayish-white mold that can be rubbed off easily.

The diagnostic key for wheat diseases on page 15 begins by separating diseases of seedlings from diseases of older plants. Since the wheat in this field is well beyond the seedling stage, we follow the statement, "Older plants diseased," to section 4 of the key. Here diseases of vegetative and of fruiting parts are separated, those of vegetative parts being referred to section 5. Under 5 we find definite reference in the second statement to discolored spots, and this takes us to section 8. There the fact that our disease is on leaves takes us on again to section 15, but since we find no pustules we must proceed, as directed, to section 16. Here the reference to discolored spots on leaves sends us on to section 17, in which we find that the first statement, "Spots thinly covered by a superficial, powdery mold," exactly describes what we have observed. So we know that the disease that has attracted our attention is powdery mildew.

A check on the accuracy of a diagnosis may be made by turning to the description of the disease in the text. If the detailed description and the picture given there agree with what has been observed, the determination is correct. If not, it is advisable to start at the beginning and work through the key again. In different diseases, symptoms sometimes may be so similar as to cause confusion, resulting in an erroneous diagnosis. It is important to keep in mind that both items in any one section of the key must be considered before deciding which applies to the case at hand.

Some diseases of plants are so difficult to diagnose from external symptoms that it is impossible for the grower to arrive at a determination from the use of a key. In such cases, the services of an expert plant pathologist are necessary. In submitting samples to an expert, the grower should include three or four representative specimens showing the typical diseased condition, since it is often difficult, if not impossible, to make a definite diagnosis from a single specimen. It is advisable to submit entire plants, including roots, since the disease may have originated in a different portion of the plant from that in which symptoms are noted. Specimens should be submitted in as fresh a condition as possible, but moisture should not be added as it tends to stimulate mold growth. Material usually reaches the expert's laboratory in good condition if it is wrapped first in oiled paper and then in heavy wrapping paper.

## II

### *Wheat Diseases*

In Illinois the wheat crop is subject to attack by 33 recognized diseases. Not all of these are widespread or important, but it has been estimated that in 12 recent years those that are widespread and commonly destructive have brought about a re-

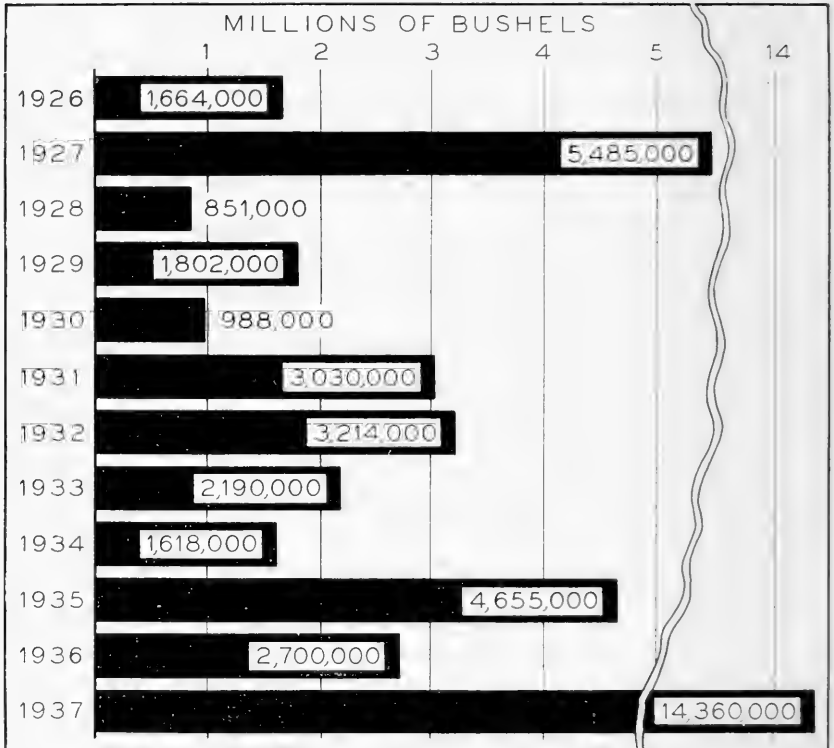

Fig. 3.—Estimated reductions in Illinois wheat yields, 1926-1937, due to disease attack. The average annual reduction for the years represented is more than 3,500,000 bushels.

duction in yield amounting to at least 42,557,000 bushels, an average of more than 3,500,000 bushels per year, fig. 3. While much of this apparent loss could not have been prevented, since no practical means have existed for controlling some of the most destructive diseases, much of it could have been avoided had

known methods of combating certain diseases been in general use.

The descriptions on the following pages deal mainly with diseases that are common and widespread, but a few now local in occurrence or apt to invade Illinois are described because of the importance they might have in the future.

### DIAGNOSTIC KEY FOR WHEAT DISEASES

1. Seedlings diseased.....	2
Older plants diseased.....	4
2. Seedlings rot off at the ground line and fall over.....	Helminthosporium disease, p. 33
Seedlings exhibit other symptoms of disease.....	3
3. Seedlings are at first stunted and later turn yellow and die; their roots are rotted, reddish brown and sometimes covered with gray or pink mold.....	Scab, p. 28
Seedling leaves are rolled, twisted, curled or other- wise distorted.....	Nematode disease, p. 56
4. Vegetative parts of the plant (roots, leaves or stem) diseased.....	5
Fruiting part of the plant (the head) diseased.....	21
5. Stem and leaves stunted, light colored or with light green streaks, maturing early or dying before maturity; roots often rotted.....	6
Leaves or stems obviously diseased, bearing pustules, stripes or discolored spots.....	8
6. Leaves mottled with alternating fine streaks of dark and yellow green, plants often dwarfed and roset- ted, roots apparently healthy.....	Mosaic, p. 52
Leaves lacking a mottled pattern, roots obviously diseased.....	7
7. Roots covered with small, irregular, brown spots, or else the entire root decayed, brown and brittle.....	Helminthosporium disease, p. 33
Roots brown and dead by jointing time, those near the crown thicker than normal and woolly.....	Take-all, p. 55
8. Disease attack apparent chiefly on the stem.....	9
Disease attack apparent chiefly on the leaves.....	15
9. Stems bearing red or black pustules or stripes.....	10
Stems affected with discolored spots or blotches.....	11
10. Pustules reddish or black, with ragged edges....	Black stem rust, p. 20
Stripes very long, at first lead colored, later rup- turing and emitting black powder.....	Flag smut, p. 40
11. Stems discolored at or near the joints.....	12
Stems discolored elsewhere.....	13
12. Discolorations sparingly dotted with black pustules..	Glume blotch, p. 47
Discolorations brownish and water soaked.....	Anthraco-nose, p. 31
13. Upper part of stem affected; water-soaked, black- brown stripes present.....	Black chaff, p. 45
Basal part of stem affected.....	14

14. Stem base bearing numerous rust-brown spots or streaks.....Helminthosporium disease, p. 33  
Stem base dark brown to black, usually a plate of fungous tissue between the stem and sheath.....Take-all, p. 55
15. Leaves with orange-red, open pustules or black, covered pustules.....Leaf rust, p. 17  
Leaves showing symptoms other than pustules..... 16
16. Leaves green throughout but wrinkled, twisted or otherwise deformed.....Nematode disease, p. 56  
Leaves discolored by spots, which are generally brown..... 17
17. Spots thinly covered by a superficial, powdery mold.....Powdery mildew, p. 50  
No mold on the outside of the leaf..... 18
18. Leaves bearing very long, lead-colored stripes which break open and discharge a black powder.....Flag smut, p. 40  
Spots on the leaves round to oval or elongated..... 19
19. Leaf spots elongated, tan to reddish brown, studded with black dots.....Speckled leaf blotch, p. 25  
Leaf spots round to oval, definitely brown bordered..... 20
20. Leaf spots dark brown, with a few black dots.....Glume blotch, p. 47  
Leaf spots light or dark tan, without black dots.....Helminthosporium disease, p. 33
21. Chaff and grain entirely replaced by a mass of black powder.....Loose smut, p. 38  
Chaff not replaced by black powder..... 22
22. Heads normal, or nearly so, in color..... 23  
At least the chaff showing definite discolorations..... 25
23. Kernels, when crushed, breaking up into a foul-smelling black powder.....Stinking smut, p. 36  
Kernels solid..... 24
24. Kernels expanded into long, hard, black bodies.....Ergot, p. 50  
Kernels short and hard, the heads shorter, and staying green longer, than normal.....Nematode disease, p. 56
25. Part of the head, or all of it, blighted and ripening prematurely..... 26  
Head ripening more or less normally..... 27
26. Affected parts of the head with very minute black dots on the surface.....Anthracnose, p. 31  
Affected parts of the head clear or often covered by pink mold.....Scab, p. 28
27. Chaff blackened, sometimes with beards twisted and blackened.....Black chaff, p. 45  
Chaff discolored with blotches or spots..... 28
28. Dull water-soaked areas at the base of the chaff..Basal glume rot, p. 43  
Discolorations on the upper part of the chaff..... 29
29. Chaff showing dark, sunken stripes on the upper part.....Black chaff, p. 45  
Chaff showing definite spots..... 30
30. Spots irregular, brown with light centers containing a few black dots.....Glume blotch, p. 47  
Spots well defined, tan with brown borders.....Helminthosporium disease, p. 33

## LEAF RUST

*Puccinia rubigo-vera*, var. *triticea*

Leaf rust, less commonly called orange leaf rust, attacks only wheat and, so far as is known, does not infect wild grasses. Like all rust diseases of cereals, it is capable of making use of an alternate host, but in America apparently does not do so com-

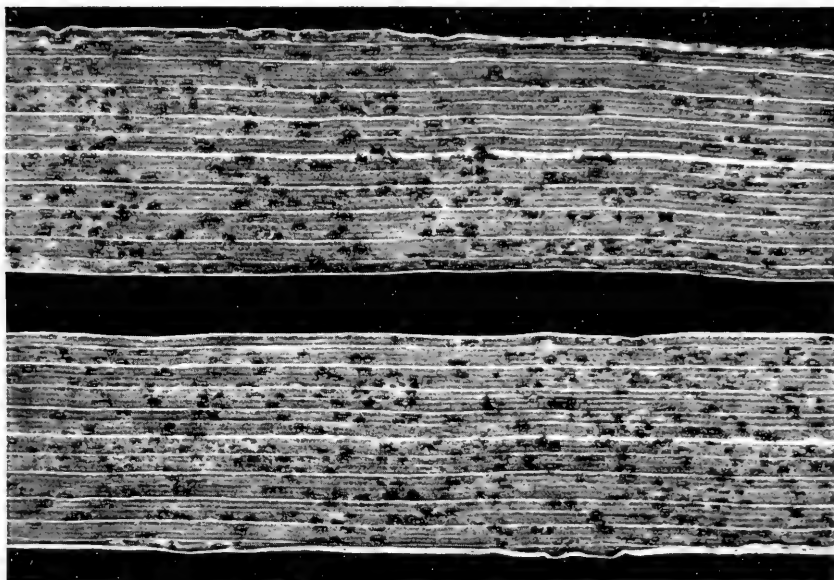

Fig. 4.—Leaf rust of wheat. The dark spots scattered over the leaves, between the veins, are the rust pustules. These are orange red during the growing season and produce the rust spores by which the disease is spread.

monly. Specialized forms, like those of stem rust (see page 20), show considerable selectivity with regard to the wheat varieties they attack, and over 40 such forms have been found to occur in the United States.

**Appearance.**—As its name implies, leaf rust is found mainly on wheat leaves. Here it shows as small, round, raised, orange pustules the size of a pinhead or smaller, fig. 4. In the early part of the growing season these pustules are few in number and scattered irregularly over the leaf surface. Later in the season they become very abundant, and in years of heavy rust all the leaves appear plastered with them. Leaf rust pustules owe their color to the masses of summer spores they contain.

As wheat nears maturity, other pustules of about the same size, but dark in color and less ragged and powdery, appear in abundance, both on the leaves and on the sheaths; both types of pustules remain until the wheat plant has matured and died.

**Life History.**—It has been proved experimentally that the wheat leaf rust fungus has an extended and complicated life history, like that described for stem rust, in which five distinct kinds of spores are produced and use is made of an alternate host that is neither one of the cereals nor a grass. The spores formed in the dark, closed pustules as the wheat plant ripens serve to carry the fungus over winter. In the spring these spores germinate, sending out short tubes bearing four short branches, on each of which a special spore is formed that is capable of infecting only herbs known as meadow rue, which botanists call *Thalictrum*. However, no instance of the natural occurrence of this rust on meadow rue has been found in Illinois. In experiments, minute spores have been produced on the upper surfaces of the swellings on artificially infected meadow rue leaves and cluster cups filled with spores on the lower surfaces. Spores from the cluster cups, if transferred to wheat, would produce infection, followed first by orange pustules from which summer spores are shed and later by dark pustules containing winter spores. Native American meadow rue species have proved less susceptible to leaf rust than foreign species.

For practical purposes, the life history of wheat leaf rust in Illinois, as also throughout North America, may be considered as limited to the summer spore, or orange leaf rust, stage. The orange pustules produce spores in enormous numbers, and these are caught up on the wind and carried short or very long distances. Undoubtedly the rust overwinters in its summer spore stage in southern states, perhaps even in Illinois, and in the spring is carried northward on the wind, producing new infection as soon as favorable weather occurs. Once established in a wheat field, it produces summer spores in such great abundance as to assure its spread throughout that field.

**Importance.**—Taken year after year, leaf rust is the most serious disease attacking wheat in Illinois, outranking even speckled leaf spot in destructiveness. Estimates covering a continuous 10-year period indicate an average reduction in yield of 4 per cent, equivalent to approximately 1,370,000 bushels annually. Losses have ranged from as little as a trace, in 1928, to as high as 12.5 per cent, in 1935, and during the period 1926 to

1935 have amounted, in total, to 53 per cent of all wheat losses attributed to disease attack.

The destructiveness of leaf rust is due to its effect upon leaf tissues. Light rust attacks which occupy only small amounts

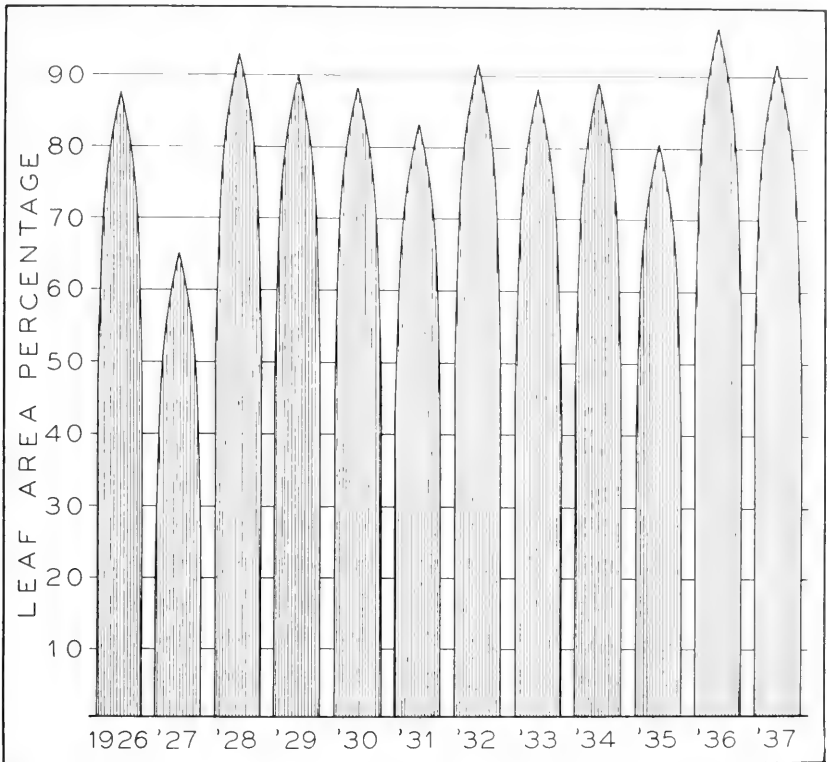

Fig. 5.—Effect of leaf rust on the leaf area of wheat plants in Illinois fields, 1926-1937. The rust attacks of different years destroy varying amounts of leaf tissue, leaving only the average leaf areas shown in the diagram to produce the state's crop.

of leaf tissue affect yield probably but little, but heavy attacks that seem to transform leaves completely into pustule masses destroy so much leaf tissue that good yields are impossible.

Leaf rust is commonly regarded as an epidemic disease. It is, of course, present in the wheat fields of the state every year, but variations in weather, which strongly influence spore germination and infection, cause noticeable differences in the annual attacks. These differences are discernible, first, with respect to the actual number of stems bearing diseased leaves and, second,

with respect to the actual amount of rust infection present on the leaves. Commonly in Illinois nearly every stalk of wheat in the state bears rusted leaves by harvest time, and differences between annual epidemics lie chiefly in the amounts of rust infection on the leaves. Careful measurement of rust samples have been made in Illinois every season since 1922, and the variations in the epidemics determined statistically. Fig. 5 shows how these epidemics have affected the average leaf area of wheat in Illinois each year from 1926 through 1937.

**Control.**—The only practical means of controlling leaf rust lies in the use of resistant varieties. Kanred and Turkey wheats and selections of Fultz and Michigan Amber are highly resistant. Hybrids of these selections also show outstanding resistance to winter injury and scab. Two or more applications of powdered sulfur have been shown to give good control, but under present conditions sulfur dusting of wheat fields is not practical. The addition of nitrogen in moderate amounts to soils deficient in this element has resulted in increased yield but it has also tended to increase the intensity of the rust attack. Adding potassium and phosphorus to soils deficient in these elements, as well as in nitrogen, has been shown experimentally to increase yield without increasing susceptibility of the wheat plants to leaf rust.

## BLACK STEM RUST

*Puccinia graminis*

Black stem rust, a disease that attacks all the small grains and many wild and cultivated grasses besides, is caused by a fungus that has a very complex life history. Five different kinds of spores are produced, and an alternate host, the common barberry, is required for the completion of its full life cycle.

The fungus has become differentiated into a number of specialized forms which exhibit strict preferences with regard to the hosts they attack. The form that attacks wheat also attacks barley and rarely rye, but not oats, while the form that attacks oats seldom, if ever, attacks wheat, barley or rye. The form that attacks any given crop is usually still more highly specialized in host preference and consists of races which are rather strictly limited to definite host varieties. More than 80 such races of the form that attacks wheat are known to occur in North America.

Black stem rust occurs in the wheat fields of the state every



year and it also attacks common grasses such as brome grass, squirrel tail and wheat grasses.

**Appearance.**—Black stem rust of wheat is recognized readily by the elongated, ragged pustules it produces on the stem, leaf sheath, chaff and beard, fig. 6. Pustules usually begin to

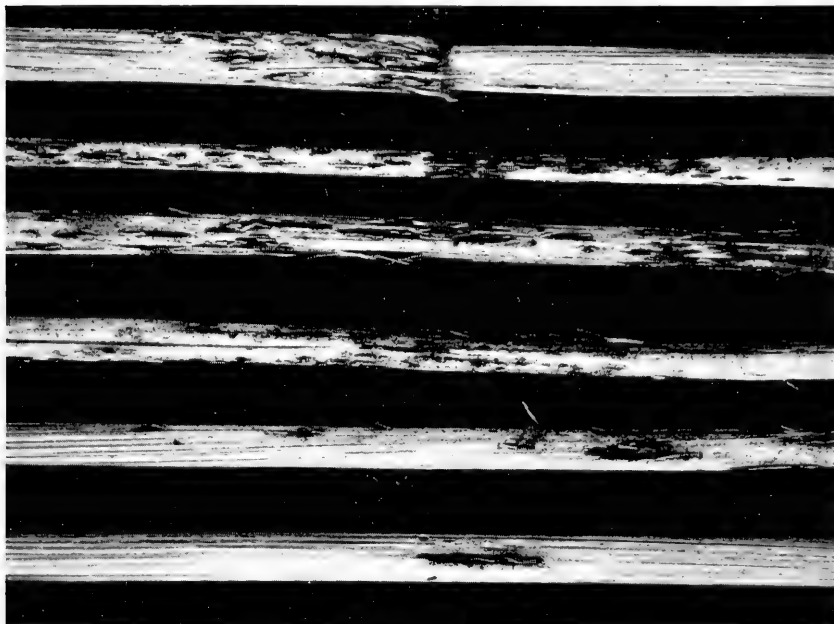

Fig. 6.—Black stem rust on wheat. The ragged-edged scars are the black pustules which bear the spores by which the rust fungus overwinters.

appear in June and from that time on increase in number until the wheat is ripe. Soon after appearing, they rupture the stem tissue, exposing the powdery, red mass of summer spores. Fragments of the wheat epidermis adhere to the sides and ends of the pustules, giving them a ragged appearance, especially at the ends. This ragged appearance and the length of the pustules are two characteristics which distinguish black stem rust from leaf rust. Individual pustules may be a quarter inch or more long, and in heavy infections two or more may run together and form streaks. As wheat nears maturity, the rust fungus forms the black pustules filled with the black spores from which the disease gets its name.

**Life History.**—The final effort of the black stem rust fungus, as the wheat plant nears maturity, is the production of its

black spore stage. In this form it overwinters on stubble, straw and the dead stems of grasses, for these spores are not shed from the pustules in which they are formed. In the spring the black



Fig. 7.—The cluster cup form of black stem rust as it appears on the common barberry. Spores borne in the tiny cups, when carried by air currents to nearby grains, start a season's epidemic. (Photograph furnished by Bureau of Entomology and Plant Quarantine, U. S. Department of Agriculture.)

spores germinate, giving rise to a very short tube with four stubby branches, each of which produces a small round spore at its tip. In order to cause infection, these spores must be blown to a leaf of the common barberry plant. Once a barberry leaf is infected, the fungus grows within it and early in May produces

a swollen place on the leaf. Shortly afterward there appear on the upper surface of these swellings very tiny, porelike openings from which issue quantities of exceedingly minute spores suspended in drops of nectarlike liquid. Distribution of these spores to swollen areas other than those in which they are produced accomplishes a process of fertilization similar to pollination, the result of which is the formation on the undersides of the swellings of minute, spore-filled cups—the cluster cup stage of the rust fungus, fig. 7.

Spores dropping from the cluster cups are caught up by breezes and carried some distance from the shrub on which they were produced. If they chance to light on a grass or grain plant susceptible to black stem rust, they germinate and bring about infection. The fungus now grows within the tissue of the new host and very soon breaks out as brick-red pustules filled with red summer spores. This is the stage in the life cycle of the rust that is commonly known as red rust. The red spores are shed as soon as they are produced and are carried by the wind, not only to near-by plants but also for considerable distances. Alighting on wheat plants, they germinate and infect them, and after a short period new pustules appear from which a new crop of spores is distributed. The time required for the summer cycle of infection ranges from 8 to 14 days. Its constant repetition through the growing season, coupled with the enormous number of spores produced, results in exceedingly destructive stem rust epidemics when weather favorable to spore germination prevails. As the wheat begins to ripen, the fungus again produces the black pustules characteristic of black stem rust.

So far as Illinois is concerned, the entire life history of the rust fungus plays only a small part, and then only in northern counties, in the development of annual epidemics. Throughout most of the state, original infection of the wheat crop is brought about by summer spores blown northward from fields farther south. Although the summer spore stage does not winter successfully in Illinois, it does so in southern Texas and Mexico, and the spring infection moves northward with the season and the developing wheat crop.

**Importance.**—The average reduction in yield caused by black stem rust on wheat in Illinois is estimated to be 0.7 per cent per year. While stem rust is not a limiting factor in wheat production in this state, as it is in some states and countries, its severity varies from year to year. In 1928 the loss was estimated

at a trace of the crop, but in 1923 a reduction of 1.5 per cent in yield amounted to 1,091,000 bushels, a money loss of \$1,025,500 to the wheat growers of the state.

**Control.**—Since stem rust infection takes place during the growing season from spores produced either on the common barberry or on other wheat plants, prevention of infection is the logical method of control. Toward this end three measures are applicable: the growing of wheat varieties resistant or immune to attack; interruption of the life cycle of the rust so that an important, infective spore type cannot be produced; and treatment of the growing wheat so that spores alighting on it do not produce infection.

Wheat varieties entirely immune to stem rust do not exist. Varieties resistant in various degrees are, however, numerous and there are types well adapted for any part of Illinois. Among the soft winter wheats Wabash seems to be a promising resistant variety. Kanred and Minturki, the first a hard, the second a semihard, red winter wheat, show definite resistance, as does also Cheyenne. Hussar, too, is very resistant but is not a good yielder. Among spring wheats, Hope is the most resistant but is not adapted to Illinois conditions, while Sturgeon, Thatcher, Kota and Komar are somewhat less resistant. Kota, however, is not considered suitable for use in Illinois. Komar is susceptible to scab attack. Reward, which shows some resistance, is grown satisfactorily in Illinois.

Control by interference with the life history of the rust fungus has been attempted in Illinois, as in other central western states, by systematic eradication of the common barberry. Since the black, overwintering stage of the rust is able to infect only the barberry, and the spores produced on barberry can infect only grains and grasses, eradication of the barberry should remove the link necessary for carrying infection over from the crop of one year to that of the next. Begun in 1918, the eradication campaign has resulted in the finding and destruction of a large number of common barberry bushes in the state.

The common barberry is a shrub brought to America by early colonists. Settlers, moving westward, carried it with them. Nurseries also distributed it widely. It propagates readily by seed and has escaped from cultivation in many places. While its eradication may not prove so generally beneficial in Illinois as in states farther north, the individual grower may profit considerably from the destruction of barberries on his farm, espe-

cially in seasons when the presence of the barberry tends to develop local, destructive epidemics.

Not all kinds of barberry shrubs harbor the black stem rust fungus. The Japanese barberry is immune to attack and can be planted and grown without endangering the wheat crop. The characteristics of the common and Japanese barberries are given below.

**Common barberry**, spring host of the black stem rust fungus, is a tall, erect woody shrub, commonly reaching 12 feet in height. Its bark is dark gray, and its coarse stems are armed with long spines. Its leaves, which are green, fairly large and bristle-toothed along the edge, grow in clusters at the stem joints, just above the spines, of which there usually are three or more at each joint. Its small, inconspicuous, yellow flowers, borne in long, drooping clusters like those of a currant, produce numerous bright red berries that stay on the shrub through the winter.

**Japanese barberry**, immune to black stem rust, is a low, spreading, graceful shrub commonly 4 to 5 feet high. Its bark is dark red and its slender stems are armed with short spines. Its leaves, which are green but often red tinted (conspicuously and beautifully so in the fall), small and smooth along the edges, grow in clusters just above the single spine at each joint. Its flowers, which are small and yellow, and its berries, which are bright red and which cling to the bush through the winter, are borne in small bunches of two or three, like those of a gooseberry.

Experimental work, both in the United States and in Canada, has shown that a decided reduction in stem rust attack, accompanied by unexpectedly large increases in yields, can be obtained if growing wheat is dusted with sulfur at intervals before heading. Successful dusting must be done at present from airplanes, and the cost is too high as yet for the method to be generally adopted, especially since the number of treatments required per season has not been satisfactorily determined.

## SPECKLED LEAF BLOTCH

*Septoria Tritici*

Speckled leaf blotch gets its name from the appearance of the blotches it causes on diseased leaves. The innumerable specks on the blotches are the blackish spore-producing bodies of the

fungus. Other names frequently used for this disease are leaf spot, nebular leaf spot and Septoria leaf spot. It is primarily a cool weather disease, attacking only leaves and sheaths and doing its greatest damage when the plant is not very active. Besides wheat, it attacks rye and bluegrass.

**Appearance.**—Speckled leaf blotch is most conspicuous early in the spring, when it appears as irregular, longitudinal, reddish-brown, often ashen-centered spots of various sizes scattered

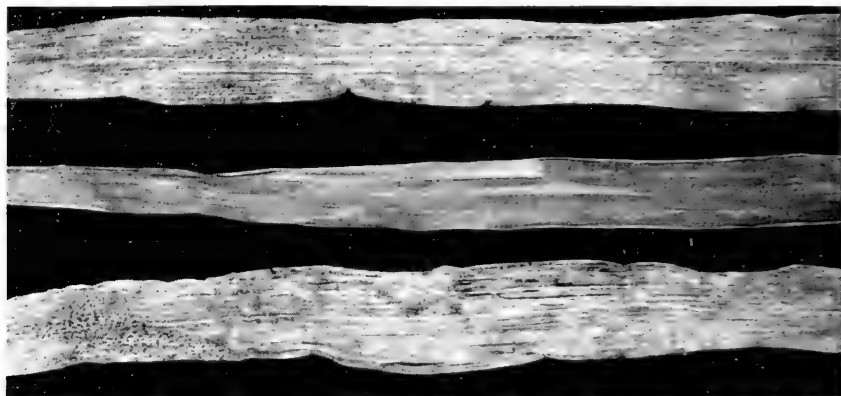

Fig. 8.—Speckled leaf blotch of wheat. The presence of the fungus is indicated by the many black dots in the blotched regions.

over the leaf surface, fig. 8. It is especially abundant on lower leaves. The spots contain many tiny, black specks not nearly as large as pinheads but plainly visible to the unaided eye. This disease exhibits symptoms that vary somewhat with the season. In late fall, it may be recognized as more or less circular to oval, speckled spots on the blades of the seedling leaves. The centers of the spots are at first light green, which shades into the natural green of the leaf, but the spots are not very conspicuous until the black fruiting bodies of the fungus are formed. In the spring the spots gradually elongate as the fungus grows in the leaf tissue, turn reddish brown and, as a rule, become partially surrounded by a yellowish band. The oldest part of the spot usually turns to light brown or even ashen white and is studded with tiny, black specks. Heavily infected leaves often have a yellowish cast and may die prematurely. Very little new infection occurs after flowering.

**Life History.**—After the wheat crop is mature and harvested, the speckled leaf blotch fungus lives through the summer

on volunteer wheat, rye and bluegrass, as well as in leaf fragments from the wheat crop. Spores shed from these infected plants are always ready to infect susceptible grains and grasses, and the spores themselves are able to remain alive for as much as a year. When the winter wheat seedlings appear in the fall, speckled leaf blotch infection occurs immediately and, since the fungus is adapted to cool weather, this infection grows and spreads until stopped by severe cold. Overwintering in the wheat leaves, it resumes activity again in the spring, maturing and broadcasting successive crops of spores, which are produced in the black specks until the wheat has matured.

**Importance.**—Though not so conspicuously destructive to maturing wheat as is leaf rust, speckled leaf blotch ranks second in importance among the diseases prevalent in Illinois wheat fields. The greatest damage is done to seedlings in the fall and to tillers in the early spring. Many tillers are found dead and almost completely covered by the spore-bearing bodies of the fungus. The rosette leaves are often killed and the greater part of their surface is usually covered by the tiny, black spore-bearing bodies. On the stems, the lowest leaves are usually the ones most severely diseased. Sometimes a spot extends entirely across the leaf, killing it at that point and causing the death of all the outward part of the leaf. Spots are often found on the blade near the point of attachment to the sheath. The destructive effect is greater than usually is realized. As many as 5 per cent of the tillers, killed by this disease, have been counted. The year 1926 was one of very light infection, when only 11 per cent of the plants examined were infected and 0.4 per cent of the leaf area destroyed, but, in 1929, 100 per cent of the plants were diseased and by harvest 65 per cent of the leaf area had been destroyed. In an average year, about 25 per cent of the leaf area is destroyed. The exact effect this disease has upon yield has not been determined, but the destruction of such large amounts of leaf tissue undoubtedly greatly reduces the yield.

**Control.**—Little attention has been given to the control of this disease. The wheat grower who wishes to prevent loss has at hand three general measures. The first of these is sanitation, requiring first that at threshing as small a quantity as possible of shattered wheat leaves be blown in the direction of any new fields and, second, that volunteer wheat and other infected grasses be kept down. The second measure, not a very satisfactory one, is the growing of resistant varieties. Illinois No. 1 is somewhat

resistant; White Marquillo, not grown in Illinois, is highly susceptible. The third measure is early planting, so that fall wheat can make good growth before the occurrence of weather cool enough for the disease.

## SCAB

*Gibberella Saubinetii*

Scab attacks wheat, oats, barley and rye, and also a number of wild grasses, including cheat, quack grass, bluegrass, wild rye and foxtail. The fungus that causes the disease is able to live not only as a virulent and destructive parasite but also as a saprophyte on dead plant material in the soil. As a parasite it causes two distinct types of disease. The best known of these, scab, is a blighting of the heads, prevalent in moist seasons, but the other, the seedling blight, is also a destructive disease, costly to grain growers throughout the state. Other crop plants are also attacked, and such diseases as stalk and ear rot of corn, and crown and root rots of clover, result.

**Appearance.**—Scab in its most conspicuous form is recognized by the premature ripening of one or more spikelets of the head any time after flowering. When wheat is in the dough stage, the light yellow color of diseased spikelets shows in sharp contrast with the healthy green of the rest of the head, fig. 9. In addition, a light pink or salmon color appears at the bases of infected spikelets and along the edge of the chaff, especially in damp weather, and this is an unfailing diagnostic character. This pink color is due to the presence of quantities of summer spores of the fungus. Kernels of severely affected spikelets have a grayish-white or salmon to reddish color, are badly shrunken and wrinkled, and have a noticeably rough, flaky seed coat. Late in the summer the heads earliest attacked become speckled with tiny, blue-black particles. Usually scab attacks from one to several of the spikelets, but the entire head is not often blighted.

Seedling blight caused by the scab fungus is first noticeable when the infected plants appear stunted. Later these plants turn yellow and die. The roots of diseased seedlings are rotted, reddish brown in color, and may be covered with a mass of grayish or pink mold. If only part of the root system is involved, the plant usually does not stool but sends up a single stem on which is produced a small head.

Poor stands often result from sowing diseased seed. Some



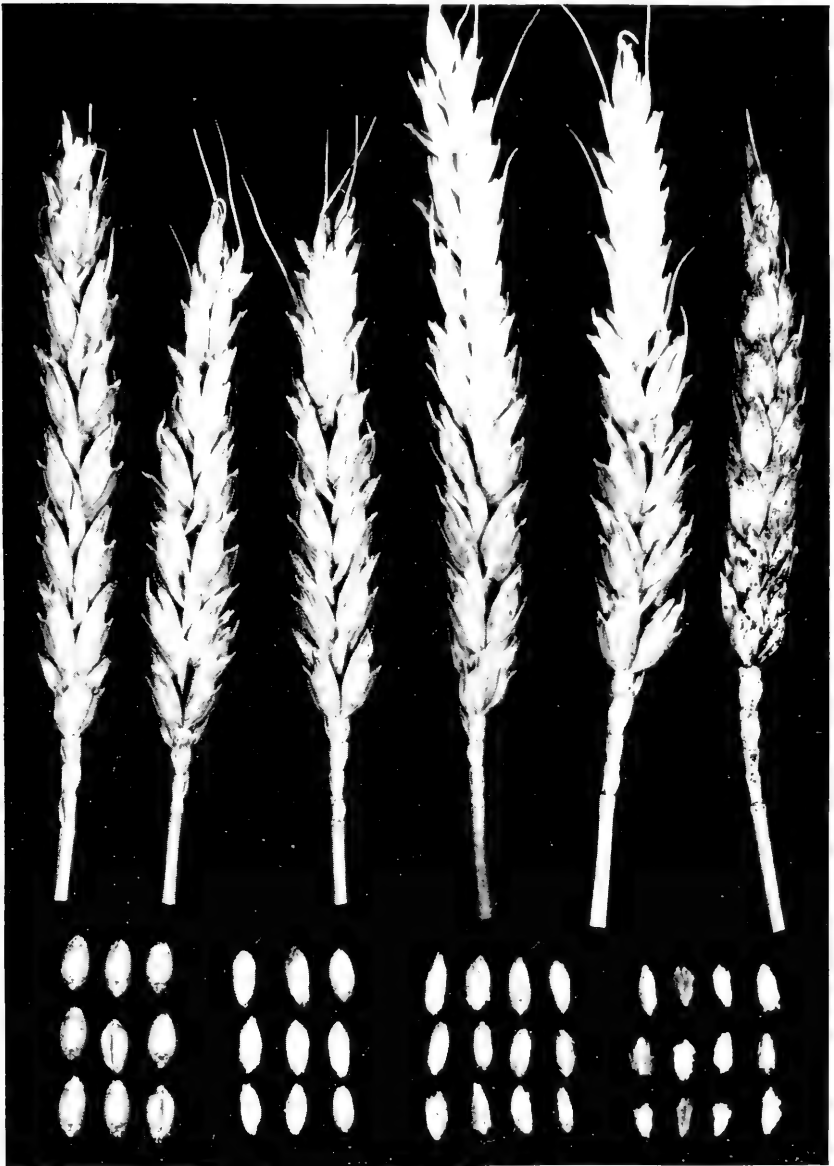

Fig. 9.—Scab on wheat. The four heads in the middle show various degrees of infection, and the head at the right, diseased throughout, shows clusters of the spore-bearing bodies of the scab fungus. The head at the left is not infected. The nine kernels at the extreme left are normal; those to the right of them show varying degrees of scab injury. Such injury lowers the market value of wheat. Even slightly injured grain, when used as seed, produces poor stands.

diseased seeds are dead before being sown, while others, though they may germinate, are too weak to send their young plants to the surface. If the sprout manages to get through the ground, it may succumb before becoming established. Some diseased plants put out new roots, and if a plant succeeds in re-rooting it may live, but it is certain to lack vigor. Seedling blight may be caused by invasion from the soil or by infection carried on the seed.

**Life History.**—The life history of the scab fungus is neither simple nor well understood. The fungus produces two distinct types of spores and it is able to exist both as a parasite of living plants and as a saprophyte on plant refuse in the soil. In the fall it is not uncommon to find its blue-black spore-bearing bodies in abundance on straw, stubble and corn stalks left in the field. These fruiting bodies, whether produced on growing plants or upon dead plant material, contain when mature many small, sacklike structures, in each of which are eight spores. These winter spores, as they are sometimes called, are discharged during rainy or continued moist spring weather. If they fall upon suitable refuse, they start to grow, soon producing large numbers of summer spores. The summer spores and the winter spores are each able to produce infection, if they fall upon a head of wheat during the blossoming period. In a week or a little longer, pink masses of summer spores may be found at the bases of infected spikelets, and these spores, caught up on the wind and carried to other wheat heads, in turn produce new infections; the process is repeated again and again so long as favorable weather persists. The fungus may live through the winter as spores on plant refuse and on the seed, and as a mold in plant debris. The mold renews its growth in the spring and produces the summer spores which are able to infect susceptible hosts.

Seedling blight is caused by infection carried in the seed, by spores that adhere to healthy seed or by the actively growing fungus living on decaying crop refuse. Head infection takes place independently of seedling blight, since the fungus is not able to grow for any distance within the plant.

**Importance.**—Grain infected with scab is usually light and chaffy. This condition reduces its feeding value and lowers its quality and consequently its market value when graded. The severity of scab infection varies greatly from year to year and is closely associated with the weather conditions that prevail following the emergence of the head. In field surveys, scab has

been found infecting as high as 16.5 per cent of the heads, destroying an average of 14.5 per cent of the spikelets. On the other hand, in exceedingly dry summers, such as that of 1930, only a trace of scab can be found in the entire state. In the 10-year period 1926-1935, with losses ranging from as little as a trace to as much as 5 per cent of a year's crop, the average loss per year was 1.1 per cent, or approximately 396,000 bushels per year.

**Control.**—The first important step in controlling scab is sanitation. This requires the destruction, by plowing under or burning, of infected stubble, straw, cornstalks, rotten ears and weed grasses that are apt to perpetuate and spread the fungus. Manure containing infected straw or cornstalks should not be used as top dressing. A rotation system in which neither wheat nor barley follows corn will lessen the degree of infection. The cereal should be planted as far as possible from old cornfields. The seed should be thoroughly fanned to remove all light, shriveled grains and then treated with *Ceresan* to kill surface-borne spores. Delaying sowing until the soil temperature is 60 degrees F. or below lessens the severity of the fungus attack on seedlings.

Resistant varieties of wheat sown in a well-prepared soil are a great aid in preventing attack. The variety selected should be adapted to the locality. Some winter wheats that have been found to show resistance are Minturki, Kanred, Fultz selections, Michigan Amber, Winter Fife, Forward, Turkey Red, Michikoff, Purkof, Red Rock and Indiana Swamp. Some resistant spring wheats are Illinois No. 1, Norka and Resaca. In the northern part of the state, Illinois No. 1 is rapidly replacing Marquis, a very susceptible variety. The durumms also are very susceptible. Garnet, Thatcher, Komar, Kota, White Australian and Progress are susceptible varieties.

## ANTHRACNOSE

*Colletotrichum cereale*

The disease known as anthracnose attacks root, stem, leaf, head and seed of wheat. Throughout Illinois it occurs also on oats, barley, rye, timothy and emmer, as well as on orchard grass, bluegrass, quack grass and cheat.

**Appearance.**—This rather inconspicuous disease is manifest oftener on the lower half of the plant than on any other part.

Following infection, purplish to brownish, water-soaked blotches are formed at or near the joints of the stem. Toward maturity of the host plant very tiny, elongated, black elevations much smaller than a pinhead appear in great abundance on the stem,

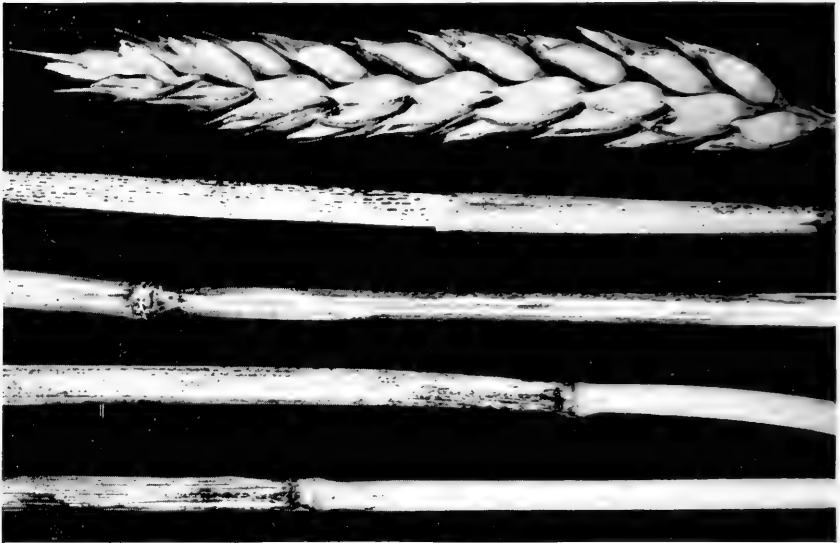

Fig. 10.—Anthracnose on wheat. Discoloration of stem joints is a characteristic of the disease, as is also the presence of the black specks on stems, sheaths and glumes. Severely infected plants ripen prematurely and bear shriveled grain.

on the leaf sheath and sometimes on the leaf, and may also be found on the chaff and spike of diseased heads, fig. 10. These tiny elevations are the spore-bearing bodies of the fungus that causes the disease.

In severe infections the presence of the disease is made evident by premature ripening or whitening of the infected plants. The blighting of heads that accompanies it is not associated with a pink mold as in the case of scab. Badly affected plants are greatly weakened, resulting in shriveled grain, the amount of shriveling depending upon the severity of the attack.

**Life History.**—The tiny black spots, found on various parts of the sick plants, late in the season produce spores which are dispersed by wind and rain to healthy plants and to the grain. It is thought that infection may occur on any part of the plant. The fungus is carried through the winter as spores on the seed, as actual infection within the seed, and on infected straw, stubble

and wild grasses. Quack grass is very susceptible and is a fruitful source of spores for new infection.

**Importance.**—The loss caused by anthracnose varies greatly from year to year, owing to the fact that the prevalence of the disease is greatly influenced by variations in weather. Records extending back to 1922 show that infection of the wheat crop has ranged from as little as a trace to as high as 50.2 per cent. Owing to the fact that the disease is obscure and not readily recognized, its importance has been underestimated, and much of the damage done by it has been attributed to rust attack.

**Control.**—While no dependable method of control has been worked out, general methods will do much to reduce losses. These are sanitation, crop rotation, thorough fanning of seed to remove light kernels and seed treatment.

## HELMINTHOSPORIUM DISEASE

### *Helminthosporium sativum*

Helminthosporium disease is also called foot rot, root rot, black joint and spot blotch, depending upon the part of the plant most severely affected. It appears also as seedling blight and leaf spot. In fact, all parts of the plant may become infected, fig. 11. Wheat and barley are most susceptible, rye is slightly susceptible, and oats and corn are almost immune. Many grasses also are susceptible to attack. Wheat may become diseased at any stage in its development, although most secondary infection occurs after heading. Certain varieties of wheat are more resistant to the disease than others.

**Appearance.**—There are two important types of injury caused by this disease. The most striking of these is characterized by the occurrence in fields of scattered, more or less circular patches of dwarfed, reddish-brown plants, which usually show a distinct rotting of the roots and the crown. But before this stage, the disease may be noticed also as a seedling blight which resembles damping-off. Badly diseased seedlings fail to reach the surface of the ground because of complete rotting of roots and shoots, while others, attacked at the ground line after emergence, die because the stem rots off. Though seedlings do not always die when attacked, some are weakened sufficiently to be stunted throughout life. Those that are most stunted usually develop only a few leaves. Others may recover and grow to maturity; in these the leaves are often darker green than the

leaves of normal plants. Severely affected seedlings usually remain dwarfed and tend to stool excessively.

As the plants become older and begin to mature, the characteristic patches of dwarfed, reddish-brown plants become quite



Fig. 11—*Helminthosporium* disease of wheat. This disease attacks wheat plants in all stages of growth. It blights seedlings, rots roots and crowns, kills young tillers, discolors the bases and joints of stems, and makes spots on leaves. Plants infected by it appear dwarfed as they approach maturity and also assume a reddish-brown tint which serves, with other symptoms, to identify the disease. Apparently resident in the soil, this disease typically attacks all plants in circular patches a few feet to several rods in diameter, doing most damage to plants in the center of the patches and injuring least the plants near the edges of the patches. (Photograph by A. G. Eldredge.)

noticeable. These patches vary in diameter from a few feet to several rods and are usually more or less circular. In size and color, the plants in these patches are graduated, those in the center being very much stunted and reddish brown and those at the outer edge nearly normal in size and greenness. Sometimes, also, plants are attacked by *Helminthosporium* disease through several feet along a row, or individually.

Roots of infected plants are discolored, and large, chocolate-colored spots develop on the base of the first leaf and also on the blades of the first and second leaves. Curling of these leaves is common. Leaves of the most heavily infected plants are pale reddish-tan in color, very narrow and about one-third as long as normal leaves. The base of the stem may have numerous spots, some streaklike and rust brown in color, covering the greater part of the foot. As the disease progresses, the inner sheath also becomes infected. The roots may be covered with small, brown, irregular spots, or the entire root system may become brittle and decayed, so that it tears off at the crown when the plant is pulled.

The second type of injury from *Helminthosporium* disease results from secondary infection on aboveground parts of the plant. On older leaves, fairly well-defined, oval to more or less longitudinal spots develop. These range from light brown to nearly black and are surrounded by a dark brown border. Death of part or of all the leaf results when several spots coalesce. The disease may also cause similar spots on the stem, beards, chaff and seed. Spots at the joint soon enlarge and involve the entire joint, which becomes a uniform brown. Except near the base, the stem between joints is seldom much discolored. The joints have a velvety appearance when the fungus fruits in abundance. Seeds often become diseased. Blotches of irregular size and shape, quite indistinct at harvest but later dark brown, may cover much of the seed. Plants are most susceptible to secondary infection after they have headed out.

**Life History.**—The fungus that causes the *Helminthosporium* disease lives over winter in the soil, in diseased crop refuse and in wild grasses, in the seed and on seedling leaves. Seedling blight is brought about by infection carried in the seed or by the fungus present in the soil. As soon as the fungus begins to produce spores in the spots on the leaves and joints, other plants are in danger of infection from these spores. In the spring, the fungus produces immense numbers of spores on infested straw and stubble, and these spores infect wheat. Seed infection, which serves to carry the fungus directly from one crop to the next, is certain to produce the disease.

**Importance.**—Because of the obscure nature of the disease and the difficulty of certain diagnosis, the importance of the *Helminthosporium* disease has been greatly underestimated in Illinois, as in most other states. Adequate data on its distribu-

tion, prevalence from year to year and destructiveness are lacking, but this disease is undoubtedly one of the important forms of foot rot and root rot so frequently and seriously destructive in Illinois wheat fields.

**Control.**—The amount of infection carried over on seed can be greatly reduced by the modified hot water seed treatment described on page 127. Long soaking in formaldehyde also reduces the amount of carry-over. But these methods do not prevent soil or secondary infections, both of which are very important. Where the disease is destructive, clean seed, sanitation, good cultural methods, rotation of crops and resistant varieties, such as Kan-red, tend to bring it under control. The fungus does not thrive so well at 40 degrees to 60 degrees F. as at higher temperatures, which suggests the advisability of late fall planting of winter wheats and early planting of spring wheats. Eradication of susceptible wild grasses such as quack grass, green foxtail, bottle brush grass, windmill grass, branching foxtail, cheat, wild rye, festuca grass and wild barley tends to reduce the abundance of infective material.

## STINKING SMUT

*Tilletia laevis*

Stinking smut, sometimes also called bunt, gets its name from the characteristic fishy odor given off by infected heads. It is not easily recognized in the field, for diseased heads often appear larger and plumper than normal heads.

**Appearance.**—A diseased head, when it first emerges from the boot, has a distinct blue cast to its green, which it retains until after normal heads are ripe. At blossoming time it is more slender than healthy heads and does not put out pollen sacks, but at maturity it is apt to appear plumper and fuller than normal heads because of its wide-spreading, open chaff. The kernel, during growth, is transformed into a smut ball, which is shorter and plumper but lighter in weight than a normal wheat grain. The smut ball consists of a mass of oily, foul-smelling, dark brown powder—the spores of the fungus. (See frontispiece.)

In the field, smutted heads usually stand more nearly erect than healthy heads, because of their lighter weight. The blue tint in diseased heads varies considerably, as does also the spreading of the chaff at maturity. In some varieties of wheat, it is



necessary to crush the kernels to make certain that heads are diseased. The offensive odor often announces the presence of heavy infection in fields and betrays the presence of quantities of smut balls in grain shipped in cars or stored in sacks or bins.

**Life History.**—Many of the smut balls are shattered during threshing, and spores thus liberated lodge on healthy kernels, especially at the brush end and in the groove. Planted in the soil with the wheat itself, the spores germinate when soil conditions become favorable. By the time the wheat sprout has emerged, the smut fungus has produced spores of another type, and these cause infection of the young wheat plant. After entering the young shoot, the fungus continues to grow as an internal parasite, eventually transforming the wheat kernels into smut balls. A single smut ball, it has been estimated, may contain between 1 million and 8 million spores. Soil can become infested with stinking smut when smut balls shatter off before or during harvest or when smut balls are actually planted along with carelessly cleaned seed. The crop grown on infested land is certain to have some disease.

**Importance.**—Two types of losses result from stinking smut infection. Smutted heads are a total loss and reduce yield in proportion to their number. The presence of much smut in threshed wheat gives it the foul smut odor and such wheat, being unfit for milling, is subject to dockage when sold. An average dockage of 8.3 cents per bushel applied on the smutty wheat raised in Illinois in 1927 amounted to a direct loss of \$64,900 in the sale value of that year's crop.

In the 14 crop seasons included in the period 1922-1935, careful counts have been made in smutted fields totaling more than 4,200 acres. Infections involving as much as 24 per cent of the heads have been seen, but the average proportion of smutted heads in infected fields stands at 2.4 per cent. The prevalence of smut varies from year to year, depending in part on the existence of favorable soil conditions following planting and in part on the extent to which preventive measures are used.

**Control.**—The following measures are important in successfully controlling this disease. Remove all smut balls by cleaning and recleaning seed; kill spores carried on healthy kernels by effective seed treatment; protect seed from contamination after treating; and protect young seedlings from soil infection.

Several effective seed treatments are described on page 118. Copper carbonate is very effective but may injure the drill and

in damp weather cause the seed to flow slowly through the drill. Organic mercury compounds give good control but are more expensive. Formaldehyde is also a good disinfectant but may cause serious injury to the seed unless great care is used in applying it. Certain selections of Turkey and Hope, a spring wheat, are resistant to the disease, but Hope is not adapted to Illinois conditions.

## LOOSE SMUT

*Ustilago Tritici*

Loose smut is the most easily recognized of all wheat diseases because of the characteristic black, dusty appearance of diseased heads, which has given it such common names as smut, black head and black smut. An important difference between this and other smuts of wheat is that the infection is carried over from season to season within the seed and not as spores on the surface of the seed. Rye is slightly susceptible to attack by this disease.

**Appearance.**—The term loose smut is very descriptive, since the fungous spores which make up the black head adhere loosely and are easily shattered off, leaving only the bare stalk, fig. 12. Loose smut is recognizable as soon as the head emerges from the boot. Usually the entire head is diseased, although sometimes part of a head remains normal and develops grain. Most of the smut mass, which consists entirely of spores of the fungus, is dislodged during the blooming period and by harvest only a bare spike remains, which is easily overlooked by the casual observer.

**Life History.**—The spore masses on smutty heads are broken up and scattered by wind, rain and other agencies. Any spore that chances to light in a flower of a healthy head germinates immediately, if moisture conditions are favorable. The fungus grows down the flower and establishes itself inside the young, developing kernel. After establishing itself, it becomes inactive and can live within the seed in a dormant state for a long time. However, when infected wheat seed that has been sown begins to sprout, the fungus also becomes active again, grows into the young shoot, up to the growing point and keeps pace with the development of the plant. As the wheat head forms, the fungus begins its own process of reproduction and replaces the entire wheat spike with a new crop of dusty, black spores which are ready to infect the flowers of healthy plants. A diseased

seed or plant cannot be told from a healthy one until the plant begins to head out.

**Importance.**—The amount of loose smut in Illinois wheat fields varies from year to year. Although single fields or limited



Fig. 12.—Loose smut of wheat. As a rule, glumes and grain are completely transformed to black powder, which shatters off, leaving the bare stem.

regions may be at times badly diseased, it is never very great for the state as a whole. The largest recorded amount of smut infection, 1.47 per cent, occurred in 1933, and the smallest amount, 0.31 per cent, in 1930. During the 14 growing seasons 1922 through 1935 the average annual infection for the state was 0.5 per cent, and during the 10 years 1926-1935 loose smut caused crop losses ranging from 100,000 to 355,000 bushels and averaging for the period somewhat more than 225,000 bushels per year.

**Control.**—Since loose smut is not surface borne on the seed, contact treatments are not effective. Any control method, to be effective, must kill the fungus inside the seed without injuring the germ of the seed. The modified hot water treatment described on page 127 does this. The thermal death point for the fungus is a few degrees less than that of the wheat seed germ. When infected seed is subjected to the hot water treatment, its temperature is raised to a point high enough to kill the fungus but not high enough to kill the seed.

Using resistant varieties tends to reduce the loss caused by loose smut. There are a number of such varieties, including Black Hull, Hussar, Preston, Berkeley Rock, Russian, Trumbull, Wyandotte, Fultz, Fulcaster, Harvest Queen, Leap, Purple Straw, Gipsy and Forward. Pure line selections of Hussar are highly resistant to stinking smut, also. Maintenance of a seed plot, as described on page 115, in which care is taken to produce disease-free seed of a variety suited to the locality, is a very dependable way of reducing loss from smut.

## FLAG SMUT

### *Urocystis Tritici*

Flag smut, introduced into the United States in comparatively recent years, is a disease very limited in distribution in the United States and in Illinois. It occurs on both sides of the Mississippi River near St. Louis, in a few counties in Kansas and Missouri near Kansas City, and in Logan County in Illinois. Quarantine restrictions, instituted by the states immediately after discovery of its presence, have tended to delay its spread. Potentially a very destructive disease, it should be guarded against in every disease-free locality.

**Appearance.**—Flag smut lesions occur on the leaves, the leaf sheaths and the upper part of the stem as long, lead-colored

to black stripes or lines running lengthwise of the spirally twisted and deformed plant parts, fig. 13. The affected leaves, which often are rolled and twisted, split along the stripes and liberate the



Fig. 13.—Flag smut of wheat. Dark stripes running lengthwise of the leaves and twisted sheaths break open, shedding the smut spores during the growth period in the field as well as during threshing. Infected plants are dwarfed; they seldom head out and are easily overlooked in a ripening field.

smut spores with which the stripes are filled. In very early stages these stripes are lighter green than the rest of the leaf, but soon they develop a leaden and later a black color. They first appear in the upper leaves of diseased plants, before the plants begin to joint, and become very conspicuous by heading time. Infected plants are dwarfed and seldom head out, but if they head out they will have the smut stripes on the upper part of the stem

and usually also on the chaff. Flag smut resembles stem smut of rye but is caused by a different fungus.

**Life History.**—The long, leaden stripes characteristic of flag smut are filled with enormous numbers of peculiar smut spores known as spore-balls. When the stripes crack open, or are broken open, these spore-balls are set free. Falling on the ground, they infect the land so that subsequent wheat crops are in danger of becoming diseased. When wheat is threshed, the straw of smutted plants gives up the spores it contains, and these spores are spread over the threshed grain as well as throughout the straw and chaff. If contaminated grain is used for seed, it carries with it into the soil the spores of the flag smut fungus.

Whether dropped directly from infected standing wheat plants or carried on the planted seed, the flag smut spores, once in the ground, germinate when favorable moisture and temperature conditions occur. The result is the production, within a short time, of a second crop of spores much different in appearance from the original spores. Spores of this second crop, formed at about the time the sprout emerges from the wheat kernel, proceed immediately to germinate, those in the very near vicinity of the young sprout reaching and infecting it. Having gained entrance into the wheat plant, the smut organism overwinters there, and in the spring resumes growth along with the host, which it dwarfs, distorts and finally kills. But before the death of its host, it produces the spore-bearing stripes, to perpetuate itself through another year.

**Importance.**—The loss due to flag smut is easily overlooked, because diseased plants are short and are nearly dead before the main crop ripens. At present the average loss is small, but fields have been found in which from 5 to 30 per cent of the plants were affected.

**Control.**—The growing of immune or highly resistant wheat varieties adapted to the infested region is the best method of control, but where this is not possible seed treatment should be supplemented by crop rotation and sanitation. Soft red winter wheats are best suited to the region of heaviest infestation in Illinois. Varieties outstanding for yield and resistance to flag smut are Fulcaster, Red Rock, Shepherd, Trumbull, Gladden, Forward and Fulhio. Beardless immune varieties are Beechwood, Early Harvest and Shepherd. Among the highly resistant varieties are Dietz, Gipsy, Reliable, Valley, Michigan Amber and a Red Cross selection, the last two being beardless. Turkey and

Kanred, hard red winter wheats, are immune to attack but have not been found suitable in heavily infested areas. The following susceptible varieties should not be sown in infested areas: Harvest Queen, Flint, Fultz, Jones Fife, Red Wave and Red Cross.

Copper carbonate, *Ceresan*, formaldehyde and copper sulfate-lime seed treatments are effective in killing spores carried on the seed but do not prevent infection from the soil. The copper carbonate treatment is probably the most practical since it is cheap, causes no seed injury and is easy to apply.

Flag smut spores are able to remain alive in the soil for more than a year in dry regions. In Illinois, the moisture is sufficient between harvest and seeding to cause most spores to germinate and die before the wheat is sown. However, there is some carry-over, and if the land is cropped to wheat year after year the disease is certain to increase. Hence, crop rotation is an important step in control.

Burning infected straw and stubble destroys great quantities of spores. If straw is saved it should not be put on land that is to be sown to wheat within two years. Late sowing of wheat tends to lessen the severity of the disease, since the smut spores germinate very poorly or not at all when the soil is cold. It has been found that no flag smut developed on wheat sown on November 15 or later in Madison County. This time, however, is too late to expect a good yield, and the date of seeding should be chosen to give the maximum both of yield and smut control.

## BASAL GLUME ROT

*Bacterium atrofaciens*

Basal glume rot is a bacterial disease that attacks chiefly the chaff and grain of wheat. No other cereal is affected by it.

**Appearance.**—The outstanding symptom of the disease is a dull brownish-black discolored area found at the base of the chaff, fig. 14. The discoloration is more pronounced on the inside than on the outside of the diseased chaff. Usually less than the lower third of the chaff is discolored, but sometimes the entire chaff is darkened. Severely infected spikelets are often slightly dwarfed and lighter in color than healthy ones. The only sign of disease on many heads is to be found on the inside of the chaff, as a dark line at the attachment of the chaff to the spike. The base of diseased grain shows a discoloration varying from faint brown to charcoal black, depending upon the severity of the attack.

When leaves are attacked, small, dark, water-soaked spots are produced. These tend to enlarge and elongate and turn first yellow and finally brown as the tissue dies.

**Life History.**—Since basal glume rot occurs in very close

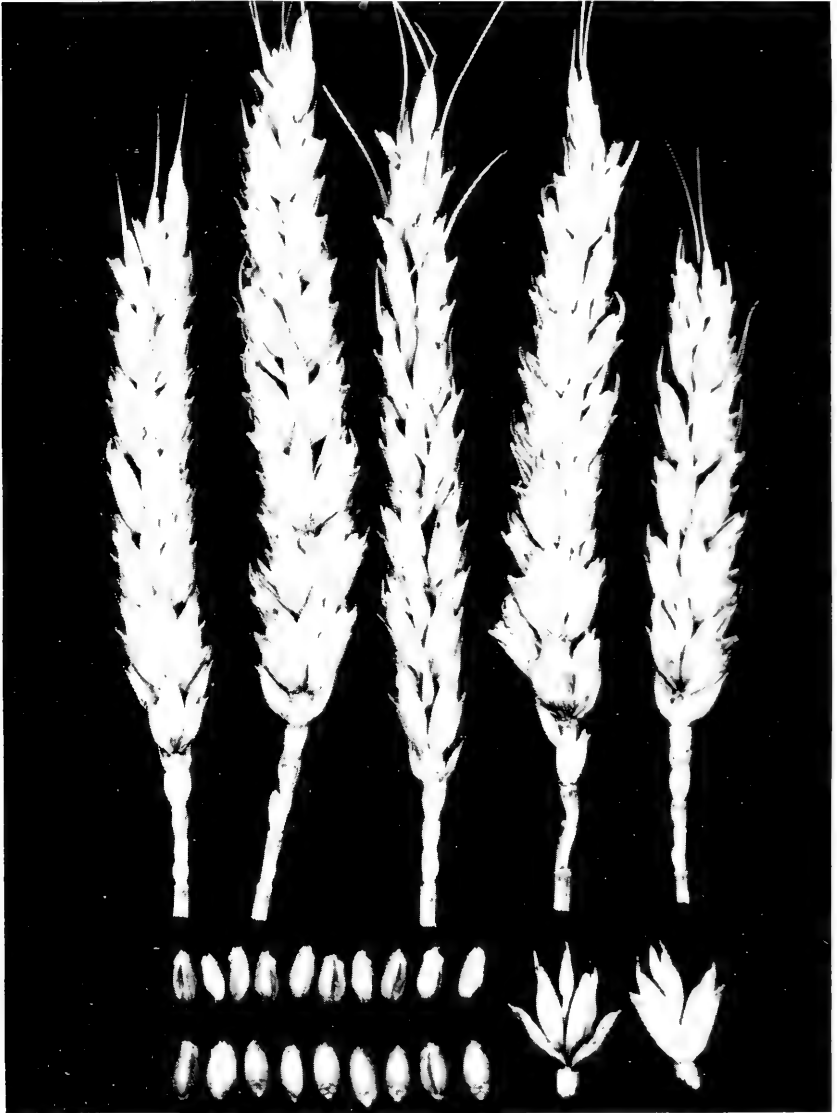

Fig. 14.—Basal glume rot of wheat. Bacterial infection discolors and rots the bases of the glumes and causes the kernels to be small and shriveled. Severe infections may lower appreciably the market value of the harvested crop.



association with the developing grain, it no doubt is carried over from year to year on infected seed. But the infected chaff and leaf fragments, blown abroad at threshing time or returned to the field as fertilizer, also serve to perpetuate the disease.

**Importance.**—Basal glume rot is a disease of only minor importance in Illinois. The average loss, as estimated from observations made in Illinois wheat fields over a period of years, amounts to about 0.3 per cent of the crop, but in 1927, when the disease appeared on 4.6 per cent of the wheat heads, a reduction in yield of 0.6 per cent amounted to a cash loss of \$210,300.

**Control.**—Proved control measures are wanting, but the recommendations given on page 47 for black chaff should aid in controlling basal glume rot.

## BLACK CHAFF

*Bacterium translucens*, var. *undulosum*

Black chaff is a bacterial disease that readily attacks both wheat and barley. It attacks rye and spelt, also. The presence of the bacteria may be demonstrated by taking a small bit of diseased glume and placing it in a drop of water on a piece of glass. The bacteria issue from the glume in such abundance that they cloud the water.

**Appearance.**—As the name implies, this disease occurs chiefly on the chaff and can be recognized as longitudinal, dark, more or less sunken stripes or spots, fig. 15, more abundant and noticeable as a rule on the upper than on the lower half of the chaff, where they often coalesce to form larger spots or blotches. The inner part of diseased chaff is brown or black spotted and the beards of bearded varieties are often brownish, especially at the base. In moist weather tiny yellow beads of bacteria ooze to the surface of the black lesions and, upon drying, appear as minute yellowish scales.

Other parts of the plant are sometimes affected by black chaff. On the leaves and sheaths, the disease produces yellow or translucent stripes and on the stem it causes water-soaked or brown to black stripes. When kernels are badly diseased they are shrunken and, especially at the base, have a honeycombed appearance due to minute pockets of bacteria. When the disease appears early and is severe, infected heads are dwarfed, spikelets fail to develop, beards are twisted and discolored, and the spike is badly blackened.

**Life History.**—The method of reproduction of a bacterium is described on page 6. The black chaff organism follows this method and in dry storage is able to remain alive on kernels



Fig. 15.—Black chaff of wheat. Bacteria, invading the tissues of the glumes, produce dark stripes on the upper parts of the glumes. Heavy infection may greatly reduce yield.

and in diseased tissue for at least two years. It is carried over from year to year by seed and chaff.

**Importance.**—Black chaff was first found in Illinois in 1917, although undoubtedly it was present prior to that time. It occurs in all parts of the state but seldom does an appreciable amount of damage. In most years it is so rare as to pass unnoticed, but during three recent years it has been abundant enough to cause a slight reduction in yield. In 1929, 0.46 per cent of the wheat heads were infected and this infection extended to 0.29 per cent of the spikelets. In 1931, a heavier attack involved 1.6 per cent of the heads and 0.18 per cent of the spikelets. In 1933 occurred the heaviest attack so far recorded, with 2.7 per cent of the heads and 0.37 per cent of the spikelets involved.

**Control.**—Since the disease-producing organism is carried over winter in and on the seed, use of clean seed is necessary for control, especially after a year of severe attack. Thorough fanning, by removing light kernels, will discard many seeds that carry internal infection. Surface-borne bacteria can be killed by treating seed with formaldehyde by the presoak method described on page 126. A 1 to 1,000 copper sulfate solution, followed by a lime bath and rapid drying as described on page 121, is also effective. Application of sulfur dust, at various intervals after heading, has successfully controlled the disease in Canadian experiments. Seed treatment for this disease alone is not recommended in Illinois, unless it becomes more severe than at present.

## GLUME BLOTCH

*Septoria nodorum*

Glume blotch, also called glume spot, is one of three diseases prevalent in Illinois that attack the chaff of wheat heads, and it is the only one of these caused by a fungus. Most frequently it attacks the outer chaff and beards, but it may attack stems and also leaves. In addition to wheat, it attacks bluegrass and rye. It is a warm weather disease and does not develop extensively until the crop nears maturity.

**Appearance.**—This disease, fig. 16, when first evident on the chaff, may be seen as small, irregular, brownish spots or blotches, which later enlarge and become chocolate brown. As the spots age, their centers often turn grayish white, and in this region tiny, black, pimplelike spore-bearing bodies usually can be seen. The inner surface of infected chaff is not so badly discolored

as the outer. Ordinarily only a few glumes in a head become infected, but in severe cases the entire head is attacked and turns dark brown. The joints of diseased spikes are almost black.



Fig. 16.—Glume blotch of wheat. The fungus attacks the joints most often, discoloring them and producing tiny, black spore-bearing bodies. On the glumes small, dark spots are produced, on which spore-bearing bodies are relatively rare.

On the stem the attack usually occurs at the joints, which shrivel, turn brown and later become sparingly dotted with black spore-bearing bodies. Glume blotch spots on the sheaths are dark brown and often so large as to include most of the sheath, while those on the blade of the leaf are light colored in the center and bordered with brown. In the light area a few black spore-bearing bodies appear on both leaf surfaces.

Glume blotch should not be confused either with black chaff

or with basal glume rot. Its spots have no tendency to form streaks and they are neither as sharply defined nor as dark brown as those of black chaff. Glume blotch does not present the water-soaked appearance of basal glume rot.

**Life History.**—The fungus causing this disease is supposed to live over winter chiefly in the plant refuse of the previous season's crop, but undoubtedly living infections in volunteer wheat, rye, bluegrass and young winter wheat play an important role. The summer spores, produced in black spore-bearing bodies in the diseased spots, are known to be able to live for one year. At any time during the growing season after the leaves unfold infection may occur. Infection of the wheat head occurs, after blossoming, from spores deposited by the wind or splashed there by rain. Several crops of summer spores may be produced during one growing season; a special type of winter spore is sometimes produced in old diseased material but appears not to play a very important part in the life history of the disease.

**Importance.**—Plants severely infected by glume blotch are stunted in growth, and if the sheath of the flag leaf is badly diseased the head often is noticeably deformed. Many of the tillers are killed when small, and on those that live the heads are usually only one-third to one-half the normal size and bear but a few small, shrunken kernels. On otherwise normal plants, the yield is noticeably reduced if leaves or joints become heavily infected.

In Illinois, glume blotch is one of the less important wheat diseases. Over a period of 10 years, the proportion of infected heads has ranged from as few as 0.05 per cent to as many as 35.6 per cent, and the proportion of infected spikelets from the very small number of 0.003 per cent to as much as 22.2 per cent. The annual infection, calculated from the same data, involves on the average 11.1 per cent of the heads and 3.8 per cent of the spikelets.

**Control.**—Sanitation and crop rotation are essential in controlling glume blotch, since the fungus is disseminated and lives over winter as spores in diseased plant material. The most heavily infected part of the wheat plant remains in the field after cutting. Since this usually cannot be destroyed, the next year's crop should be situated as far as possible from the crop of the year before it, for both wind and running water are important means of disseminating disease-carrying material. Thorough fanning of seed to remove all infected straw and chaff

will reduce the chance of infection from this source. The use of manure containing infected straw for top dressing the crop should be avoided. It is not advisable to use seed treatment for this disease alone, but seed treatments to combat seed-borne diseases will help in controlling this disease also.

## ERGOT

*Claviceps purpurea*

Ergot, a disease that infects the kernels, is rarely found on wheat in Illinois. It is much more frequently found attacking rye and is described in detail on page 106 as one of the diseases of that crop. Control measures are seldom necessary, but when control is demanded the measures described for the disease when it attacks rye will prove adequate.

## POWDERY MILDEW

*Erysiphe graminis*

The fungus that causes powdery mildew attacks wheat, oats, rye, barley, reedtop, Canada and Kentucky bluegrass, wild rye, squirrel tail, wood reed grass and other native grasses. However, in its parasitism it is very closely adapted to its hosts, and as a result the form of it that infects wheat will not cause infection on other crops. It belongs to a group of fungi which live chiefly on the outside of their hosts, but it makes connection with the interior by means of small, suckerlike branches which penetrate the epidermis, enter the surface cells and draw sustenance from them. Because of its superficial habit, this disease could be very easily controlled, since any fungicide put on the host would come in direct contact with the fungus and kill it.

**Appearance.**—Powdery mildew, fig. 17, is usually found on the leaves, but it may attack all aboveground parts of the plant. It is noticeable first as small, irregular or circular spots on the upper surface of the leaf. The spots enlarge as the fungus grows and may often involve large parts of the leaf. As the spots age, the fungus on them takes on a floury appearance which is due to the production of an enormous number of spores. Often the lower surface of the leaf beneath the diseased spots turns yellow and older parts of the spots turn brick red. Affected leaves become deformed and crinkled, especially if they are attacked when young; in severe cases they become brittle or they may die. As

wheat approaches maturity, small spherical bodies, seen as black specks, are scattered throughout the fungous growth on infected spots.

**Life History.**—In the floury, grayish spots on the leaves there are produced in great abundance summer spores which are



Fig. 17.—Powdery mildew on wheat. The two leaves at the left show the small patches of gray fungus, and the leaves at the right show the discolored, injured spots that result from the fungous attack. This disease occurs where growth is dense and the air humid among plants.

able to cause new infection immediately and serve to spread the disease to healthy plants during the growing season. Under favorable conditions of moisture and temperature, a new crop of spores begins to be produced in 10 days to two weeks after each infection takes place and continues to be produced until the host tissue dies. A cycle of infection, spore production, distribu-

tion and reinfection is thus established and occurs over and over throughout the growing season. The black spherical bodies developed later contain winter spores which serve to carry the fungus through the winter and produce initial infections on the new crop the next spring.

**Importance.**—Powdery mildew is found scattered in wheat fields throughout the state each year. Diseased plants are usually found in parts of the field where growth is dense and the air moist, producing conditions ideal for infection. The damage powdery mildew does to the wheat plant is due to the fact that the fungus robs the leaves of food manufactured for the plant's own use as well as to the fact that attack by the fungus reduces the amount of leaf area available for food manufacture. In severe cases, especially when wheat heads are infected, the kernels may be shriveled. The loss in yield, especially in Illinois, is slight and hard to measure.

**Control.**—This disease is not destructive enough in Illinois to justify use of control measures. However, dusting diseased plants with finely powdered sulfur will kill the fungus. Resistant varieties have been developed for use where the disease is destructive. But neither of these methods has been resorted to in this state. Crop rotation and the avoidance of thick stands tend to minimize the chances of heavy infection.

## MOSAIC

### *Triticum Virus 1*

Wheat mosaic, or rosette, differs from other diseases attacking cereals in that it is caused not by a fungus or bacterium but by a virus, which is an infective principle so minute as to be invisible even under the highest magnifications of the modern microscope. The wheat mosaic virus carries over from one year to the next in the soil; it has been transmitted experimentally by aphids. Its host range is limited to a closely related group of grasses, which includes rye, wheat grasses, barleys, wild rye and bottle brush grass.

**Appearance.**—Two types of this mosaic attack wheat in Illinois. One is yellow mosaic; the other, green mosaic, causes a rosette condition in some varieties of winter wheat. (See fig. 18.)

The most noticeable signs of mosaic appear when plants begin rapid growth in the spring, although sometimes symptoms may show on leaves in the fall. When new leaves of diseased



plants unfold they appear mottled yellow or light green, depending upon the type of mosaic present. The mottling consists of irregular yellow stripes or blotches which vary in size but tend

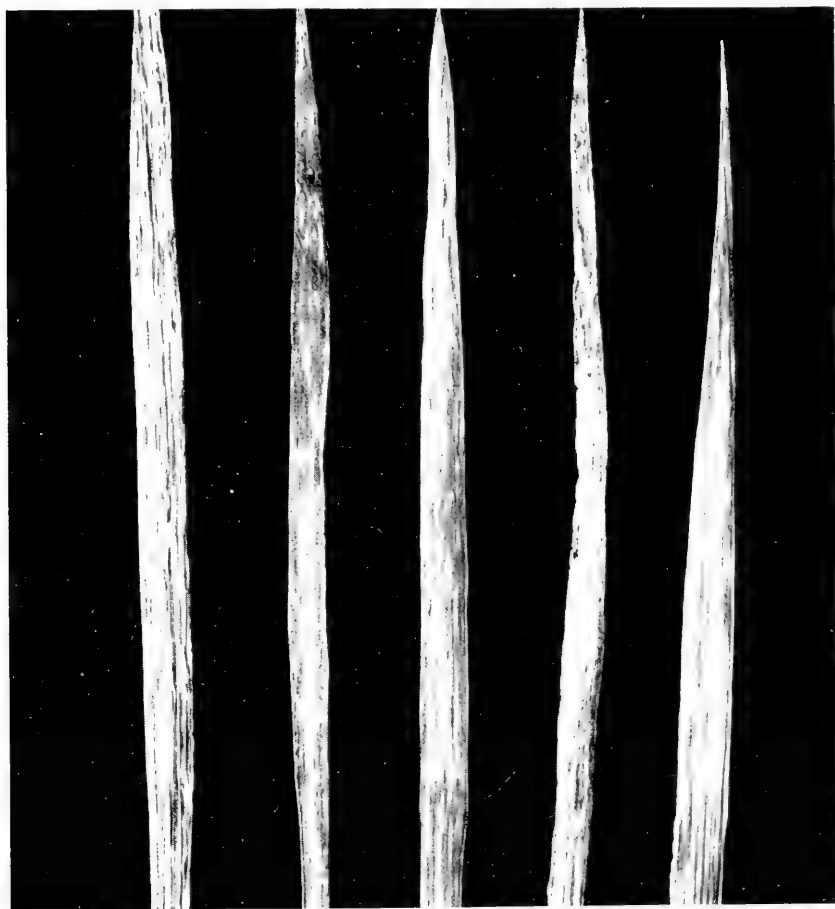

Fig. 18.—Mosaic disease on wheat. Infection of the wheat plant by a virus results in a mottling of the leaves, which is the most striking symptom of the disease.

to run parallel with the length of the leaf. In some cases of green mosaic there is so much light green color in the leaf that it looks as though it is mottled with dark green. Mottling, commonly called the mosaic pattern, may be found on the sheath and chaff as well as on the leaf blade. The disease causes a distinct stunting of plants in addition to mottling of the leaves,

and in some varieties an excessive number of tillers is developed, giving an infected plant a rosette effect. Badly diseased fields are "patchy" and uneven in appearance, the patches varying from a few plants to areas 20 feet or more in diameter. The green and yellow mottling does not always appear on all the tillers of a plant. Some plants apparently recover from the disease. Leaves of rosette plants usually develop a dark green color which masks the mosaic pattern as the plants age.

There are other causes of mottled leaves, one of which is faulty nutrition. In this case there is usually a gradual increase in the amount of mottling from the flag leaf down, and the light-colored flecks do not tend to follow the long axis of the leaf. The lower leaves may show very little green, in which case the pattern is similar to severe mosaic, but the color is usually orange yellow while in mosaic it is a lemon or faded yellow.

**Life History.**—So little is known concerning mosaic diseases and viruses that no life history can be given. The infective principle is found in the juice of the plant. Under experimental conditions, the disease has been transferred from infected to healthy plants by aphids. The virus lives over from year to year in the soil and is able to persist in gumbo soil for six years or more. It is not known whether it lives over in the organic material or adheres to fine particles of the soil. Sandy soils do not retain the virus as long as silts.

It is known that the occurrence of the disease depends upon the weather of fall and winter, which influences growth and dormancy of the plant. Neither winter nor spring wheat sown in the spring in infected soil shows signs of the disease, but if either is sown in the fall the disease develops. The virus is not seed borne.

**Importance.**—Mosaic may be so serious at times as practically to destroy the crop of a susceptible variety. Red Cross with white chaff and Harvest Queen are most susceptible. But the loss caused by mosaic in Illinois is not very great, since the disease, although gradually extending its range, is now not widely distributed. The most heavily infested area is along the Mississippi River valley up and down from the mouth of the Illinois River and up the Illinois as far as northern Peoria County. Few upland counties are known to have the disease. In 1935 it made its appearance in Piatt, Vermilion, Edgar and Clark counties in the eastern part of the state, and in 1937 it was found for the first time in Woodford, Fulton, Schuyler and Brown counties.

In 1935, some infested fields in Tazewell County were a complete loss and had to be plowed up and seeded to another crop.

**Control.**—The best method of preventing loss from mosaic is the use of immune or resistant varieties. Certain lots of Fulcaster and Fultz, Gladden, two selections of Jones Fife, Mediterranean, Michikof, Poole, Michigan Amber, Red Rock, Red Cross (red chaffed), Red Wave, Trumbull and Shepherd are resistant soft red wheats. Most hard wheats seem safe to sow on infected soil. Since the mosaic-infested area overlaps the flag smut-infested area, the following varieties, resistant to both diseases, are suggested: Shepherd, Red Rock, Michigan Amber, Fulcaster and Stoner, the last a Fulcaster type.

## TAKE-ALL

*Ophiobolus Cariceti*

Take-all, or "white heads," is not yet known to occur in Illinois, although it occurs in a few other states and in Australia is regarded as a very serious disease. Besides wheat it attacks barley, rye, timothy and redtop and has as wild hosts Canada bluegrass, quack grass, cheat and brome grasses.

**Appearance.**—Take-all is primarily a root disease, but as a rule symptoms do not become apparent until about jointing time. Diseased plants are stunted and have a bleached, yellowish color. Usually they occur in circular areas ranging up to several feet in diameter, or extend for several feet along a row. Very severely diseased plants are greatly dwarfed, reaching only a few inches in height, and ashen white in color. They seldom stool. Plants that reach maturity usually send up only a single head, which is of poor size, matures early and bears shriveled grain. At the base, diseased stems are dark brown to black, and a dark gelatinous plate can be found there between the stem and the inner leaf sheath.

Brown spots develop on roots during late winter and early summer. These lesions increase in number, and on badly infected plants the roots, dead and brown by jointing time, break off at the crown when the plant is pulled. Layer roots near the crown branch freely, have a woolly appearance and appear thicker than healthy roots because they retain soil when pulled. Marked reduction in stooling is characteristic of the disease. At harvest the prematurely ripened white heads often have a sooty appearance due to growths of saprophytic fungi.

Both take-all and foot rot have some of the symptoms of mosaic, such as dwarfing of plants and occurring in spots. Mosaic dwarfing, however, shows up very early in the spring. The first indication of take-all is a general yellowing, not found in mosaic. Mosaic-infected plants, as they die, turn brown, droop to the ground and form a flat tuft. With take-all, the yellow bleaches out, or a bronze color develops, and dead plants remain erect. With mosaic, no gelatinous plate develops between the leaf sheath and the stem, no white heads are formed and maturity occurs a little later than normal.

**Life History.**—The take-all fungus produces winter spores in abundance in small, black, beaked bodies developed in the gelatinous layer between the stem base and leaf sheath. These spores live for nearly a year and infect wheat in either fall or spring. Seeds from diseased plants probably do not carry the fungus, but small pieces of straw carrying the spore-producing bodies of the fungus can transport the disease considerable distances.

**Importance.**—Although take-all does not occur in Illinois, growers should watch for it and send samples of suspected plants to the Natural History Survey for positive identification. In infested areas in New York, the annual loss has been estimated as ranging from 0.5 to 2 per cent, depending upon weather conditions.

**Control.**—Since straw and stubble are the chief means of carrying the fungus, sanitation is one of the most important means of control. Burning the stubble and eradicating wild grass hosts and volunteer grain decreases the amount of infectious material. Long rotations in which a susceptible crop is used only once in four or five years serve the same purpose. Resistant varieties exist but are not suitable for Illinois.

## NEMATODE DISEASE

### *Tylenchus tritici*

Nematode disease is caused not by a fungous parasite but by a tiny, wormlike animal known technically as a nematode but usually called an eelworm. Rye is attacked almost as readily as wheat, emmer and spelt less frequently, and oats, barley and grasses seldom.

**Appearance.**—Affected plants can be detected in the seedling stage by their rolled, wrinkled, twisted or otherwise distorted

leaves. Young leaves usually buckle within the tightly closed sheaths of the older leaves. One or more of the stems of a plant may show these symptoms. Diseased plants are stunted and enlarged near the base, and the heads, which are small, retain their green color longer and have a more open appearance than healthy heads. This openness of the head, somewhat like that of stinking smut, is caused by the short, thick kernels or galls extending the chaff. The disease can be detected in threshed grain by the presence of hard, dark galls, in reality infected kernels, which are often mistaken for cockle seed, smut balls or other impurities. They can be distinguished from smut balls in that they are hard, are not filled with a black powder and do not have a fishy odor.

**Life History.**—The hard, dark galls contain thousands of the tiny, eellike nematodes, which exist in a dried-out, dormant state in the mature galls. Many of the galls shatter out in harvesting, but some are sown with the seed. When a gall is buried in the ground it decays, liberating the multitude of small eelworms within it. These migrate short distances through the soil, in which they may live for several months, and if they encounter suitable host plants they enter them near the growing point and are carried along as the plants elongate. When the heads begin to form, the worms attack them, and the production of galls results. The female nematode lays eggs in the galls, the eggs hatch and the young worms become dormant when the host plant is mature.

**Importance.**—Only a few reports of the nematode disease are recorded for Illinois and it is not an important disease here. However, the disease is widely distributed southward. Seed imported from infested states should be thoroughly examined for the presence of the galls.

**Control.**—The disease is easily controlled by using clean seed and sowing it on uninfested soil. A three-year crop rotation will starve out nematodes if susceptible crops are kept off infested land. Usually the worms can live but one year without their host plant. If galls are found in seed wheat, thorough fanning or floating the galls out in salt brine or treating seed by the modified hot water method will control the infection.

### III

## *Oats Diseases*

In Illinois oats are attacked by a group of diseases similar in kind and in effect to those that attack the other small cereals: two rust diseases, two smuts, two important leaf spots and a number of diseases common to all cereals. Stem rust of oats, though technically the same disease as stem rust of wheat, is essentially an oats disease, since the race of the stem rust fungus that attacks oats is so highly specialized as to be unable to attack other cereals. Crown rust of oats corresponds to the leaf rusts of wheat, barley and rye, and halo blight and *Helminthosporium* leaf spot of oats correspond to the *Septoria* leaf spot of wheat and to other leaf spot diseases of barley and rye.

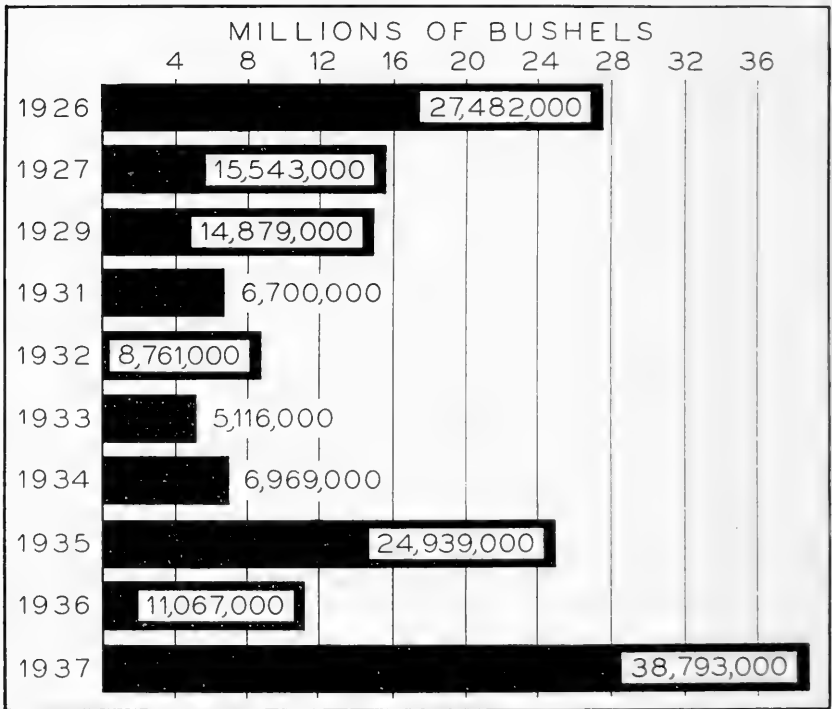

Fig. 19.—Reductions in Illinois oats yields due to disease, according to estimates available for the period 1926-1937. The average annual reduction for the years represented is estimated at 16.025,000 bushels.

Anthracnose, scab and ergot are common to all the small cereals.

For the most part oats are a spring-planted, late-maturing crop which escapes the effects of diseases such as scab and anthracnose but runs the danger of greater damage from stem rust. Owing, perhaps, to the decreasing value of oats, the destructiveness of oats diseases has not been as keenly appreciated nor as carefully analyzed as that of wheat diseases. Yet estimates of loss have been made, and for Illinois these estimates have ranged from 5 to 19 per cent of the potential crop, according to the severity of disease attack in individual years. Translated into concrete terms, these estimates indicate reductions in yield ranging from 5,116,000 to 38,793,000 bushels, fig. 19. Taking into account only the more important diseases, such estimates tend to minimize, rather than to overemphasize, the oats disease problem. It is, therefore, especially significant that in summary they indicate an average annual reduction in yield of 12.2 per cent, equivalent to 16,025,000 bushels, directly attributable to disease attack.

#### DIAGNOSTIC KEY FOR OATS DISEASES

1. Diseased plants not older than seedling stage..... 2  
Diseased plants more mature..... 3
2. Seedlings stunted, turning yellow or dying; their  
  roots reddish brown and decayed..... Scab, p. 67  
  Seedling leaves with irregular to oval,  
  reddish-brown spots..... Helminthosporium leaf spot, p. 65
3. Roots decayed, reddish brown; plants stunted, tend-  
  ing to turn yellow and die prematurely..... Scab, p. 67  
  Aboveground parts diseased..... 4
4. Heads only diseased..... 5  
  Other aboveground parts diseased..... 10
5. Grain and chaff replaced by masses of black powder..... 6  
  Neither grain nor chaff transformed to black powder..... 7
6. Black powder entirely loose and free..... Loose smut, p. 69  
  Black powder retained by a white membrane..... Covered smut, p. 71
7. Kernel transformed into an enlarged, protruding gall..... Ergot, p. 74  
  Kernel normal but shriveled, or absent..... 8
8. Entire head bleached and prematurely ripened..... Anthracnose, p. 68  
  Single spikelets affected..... 9
9. Spikelets blighted, ashen, often pink tinted..... Scab, p. 67  
  Spikelets very small, white and sterile..... Blast, p. 73
10. Disease evident chiefly on stems..... 11  
  Disease evident chiefly on leaves... .. 12
11. Stems blackened at the joints; plants often dwarfed  
  and tending to ripen prematurely..... Anthracnose, p. 68  
  Stems bearing few to many reddish to black rup-  
  tured pustules with ragged edges..... Black stem rust, p. 62

12. Leaves spotted with gray, moldy, floury appearing growth.....Powdery mildew, p. 74  
 Leaves without a superficial moldy growth..... 13
13. Leaves more or less thickly dotted with small red or black pustules.....Crown rust, p. 60  
 Leaves spotted with browned, dead tissue..... 14
14. Spots oval, surrounded by a clear, yellow halo..... Halo blight, p. 63  
 Spots irregular, reddish brown, without a halo..... Helminthosporium leaf spot, p. 65

## CROWN RUST

*Puccinia coronata*

Crown rust of oats corresponds to the leaf rusts of wheat, barley and rye and is often called oats leaf rust. The name crown rust is of scientific origin. It was used to designate the oats leaf rust fungus because of a crown, visible under the microscope, on the tip of the overwintering spore. Numerous wild grasses closely related to oats are attacked by this disease, but no cereal crop other than oats is affected. This rust exhibits very strong host preferences, and over 30 specialized races have been recognized, some local and others general in distribution.

**Appearance.**—The first crown rust infections are seen about heading time as small, scattered, oval, brownish or reddish-yellow blisters on the blade of the leaf. When these blisters break open they appear as pustules surrounded by fragments of the leaf epidermis, fig. 20. They are few at first, but as the season progresses they become numerous. Most of the pustules are found on the leaf blade but some occur also on the sheath, the stem and the chaff. They contain the summer spores of the fungus, which are responsible for spreading the disease during the remainder of the growing period, and constitute the red rust stage. As oats mature, the winter or black stage of the rust is formed. This consists of small, oblong, raised, grayish-black to black, covered pustules, some of which may form around the summer spore pustules.

**Life History.**—In many respects, the life cycle of crown rust is similar to that of stem rust. The summer spores spread the disease from plant to plant and from field to field. Following infection a new crop of summer spores can be produced in 8 to 14 days, depending upon weather conditions, and this reproductive process is repeated throughout the growing season. As oats approach maturity, the crown rust fungus produces its winter spores. These do not germinate until spring, but at that time they



produce still smaller spores which may be carried by the wind to nearby buckthorn bushes. If infection of the buckthorn leaf occurs, cluster cups are formed and in them are produced spores which in turn are carried by the wind back to oats or susceptible

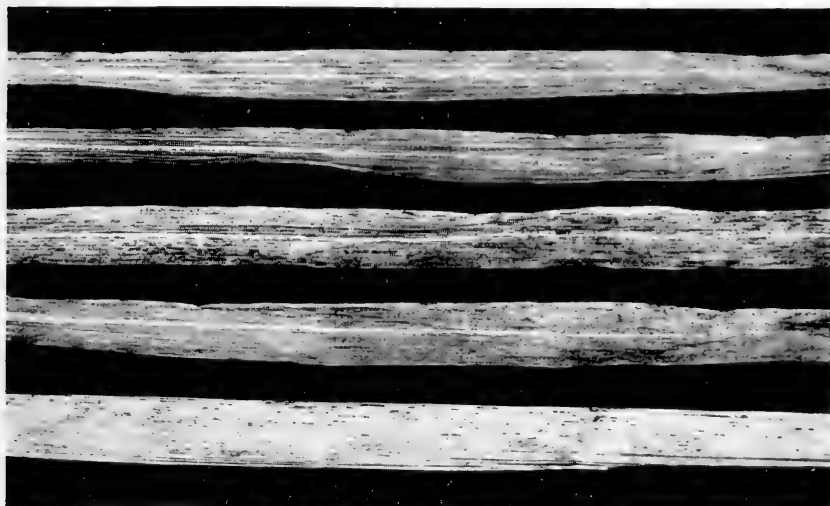

Fig. 20.—Crown rust of oats. Rust pustules occur on the leaves and sheaths. Early in the season they are reddish brown and open, as on the four leaves in the upper part of the figure; but later other pustules appear, which are black and covered, as on the leaf sheath below the four leaves.

grasses. When these are infected, summer spores are formed in pustules on the leaves, and a new season's epidemic is begun. In warm regions the summer spores survive the winter and start the new season's infection, in which case the rust does not need the buckthorn as a bridging host.

**Importance.**—Crown rust is present on the oats crop every year and, like all other epidemic diseases, varies from year to year both in prevalence and in the intensity of its attack. In years favorable to the rust, from 60 to 85 per cent of the plants in the oats fields of the state become diseased, and the presence of the rust in the leaves reduces their effective food manufacturing area by 10 to 30 per cent. In years unfavorable to the rust as little as 15 per cent of the oats plants become infected, with an accompanying reduction in leaf area of about 0.5 per cent. The average annual prevalence of crown rust in Illinois, based on 12 years of data, is 53.4 per cent, and the average reduction in leaf area is 9.7 per cent.

Reductions in yield have ranged from a trace in light rust years to 5 per cent, equivalent to 6,633,000 bushels, in a year of heavy rust attack.

**Control.**—The removal of buckthorn bushes, both cultivated and wild, in the vicinity of the farm helps to prevent repeated, heavy, local infection. Nevertheless, a light infection by wind-borne spores from the south is certain to occur under Illinois conditions. The use of early oats, which mature before the rust has had a chance to spread badly, is an excellent means of reducing loss, and early sowing of late varieties serves the same purpose.

Resistant varieties will also be helpful in reducing loss by crown rust. The red oats group is more resistant than the common oats group. Early Ripe and Golden Rustproof show the greatest resistance but are not grown extensively in Illinois. Richland is both early maturing and resistant. Glabrate, Bond, Green Mountain, Red Rustproof, an Iowa Rustless selection, Burt, Ruakura and Victoria are resistant varieties. Of these, Burt is said to give best results in Illinois. The first two are resistant to all forms of crown rust. Bond is very susceptible to stem rust. Oats varieties derived from the Kherson or White Russian types are very resistant.

Three new varieties which have been developed, Marion, Hancock and Boone, are very resistant to crown rust and are resistant to black stem rust and loose smut, also.

## BLACK STEM RUST

*Puccinia graminis*

The black stem rust of oats is caused by a variety of the stem rust fungus that cannot attack any of the other small grains. It is able, however, to attack wild oats, orchard grass and meadow fescue. Like the form on wheat, it has become specialized in its ability to attack different varieties of the cereal. There are at least 10 of these special races of black stem rust of oats.

**Appearance.**—The symptoms of black stem rust on oats are identical with those of black stem rust on wheat, which are described and pictured on page 21.

**Life History.**—The full life history of stem rust is given on page 21. An alternate host, the common barberry, serves to initiate local epidemics in the spring by serving as a bridge between overwintered infection on oats straw, or stubble, and

the new crop. Owing to the lateness of the oats, the barberry is less important with this crop than with wheat. Stem rust infection, originating largely from spores of the red rust stage blown northward from infected fields to the south, increases locally by the continuous production of this type of spore.

**Importance.**—The reduction in oats yield attributable to stem rust in Illinois is generally slight, ranging from a trace to 0.5 per cent, but in exceptional years severe rust attacks occur and reduce the yield greatly. In 1926, for example, an estimated 15 per cent reduction in yield represented a loss of 22,650,000 bushels.

**Control.**—Measures of control for stem rust, given in detail on page 24, include eradication of the common barberry, to prevent local epidemics, and the planting of resistant and early maturing varieties. White Russian, Rustproof, Iogold, Green Mountain, Anthony, Edkin, Iogren, Ruakura and Richland are resistant varieties. The first and fourth of these varieties mature late and may not be heavy yielders, because of the hot, dry weather of some Illinois summers. Green Mountain, Richland and Ruakura are resistant to crown rust, also. Three new varieties suitable to Illinois conditions, Marion, Hancock and Boone, show resistance to black stem rust, as well as to crown rust and loose smut.

## HALO BLIGHT\*

*Bacterium coronafaciens*

Halo blight, or blade blight, a bacterial disease of oats leaves, is very abundant in Illinois every year. Under outdoor conditions it occasionally attacks rye, and infection of wheat, barley and rye has been attained in the greenhouse. While it is typically a leaf disease, halo blight can also infect the leaf sheath and chaff.

**Appearance.**—Halo blight is first noticeable on the leaves as small, yellow-green, oval spots with sunken centers. As the

\*Stripe blight of oats, caused by *Bacterium striafaciens* Elliott, is widely distributed but generally of little consequence in central and western states. In 1939 it appeared in epidemic proportions in oats fields throughout central Illinois. In fields in which accurate counts were made, it attacked an average of 27.2 per cent of the oats stems and 15.6 per cent of the oats leaves. It was so severe in some fields as to render them worthless for harvesting. Stripe blight occurs chiefly on leaves but may attack sheaths, stems, pedicels and glumes. Sometimes it kills the entire top of the plant. It first appears as sunken, water-soaked dots. These dots grow into water-soaked stripes which may extend the length of the leaf blade and often have narrow, yellowish margins. In age these stripes become a rusty translucent brown. In moist weather bacteria exude from the stripes in droplets; later these droplets dry down to white scales. Stripe blight is closely related to halo blight; in fact, the bacterium causing it is distinguishable from the halo blight bacterium only by its smaller size and type of spot it produces. When control measures are necessary, those recommended for halo blight should prove effective.

season advances, these spots enlarge, reaching sometimes an inch in length, and the tissue in the center dies. The clear, translucent tissue around the dead center resembles a halo and gives the disease its name, fig. 21. Spots may be prolonged into points at one end and sometimes a faint trace of several halos may be seen in larger spots. Or the halo may be extensive and run as a streak nearly the length of the leaf. When spots occur close together and join each other, all of the leaf beyond these spots dies. In severe infections the entire leaf dries up and turns brown, but the halo usually is distinguishable even on the dead leaf. On the chaff, each minute spot of infection is surrounded by a light green to yellowish-green halo; if the entire chaff is infected, the tissue between the veins turns yellow and becomes translucent.

**Life History.**—Tests have shown that halo blight bacteria live over winter on the oats seed and cause primary infection in the spring on the first leaves. On seed these bacteria are able to remain alive for at least two years, and it seems quite possible that they may live over in the soil and on diseased plant refuse for an equal period. Infection in oats fields shows an increase after rainy periods, indicating that moisture favors development of the disease. Both rain and wind easily may spread the bacterium from plant to plant as well as to different parts of the same plant.

**Importance.**—Halo blight is important chiefly because of its destruction of leaf tissue. In Illinois oats fields it behaves as an

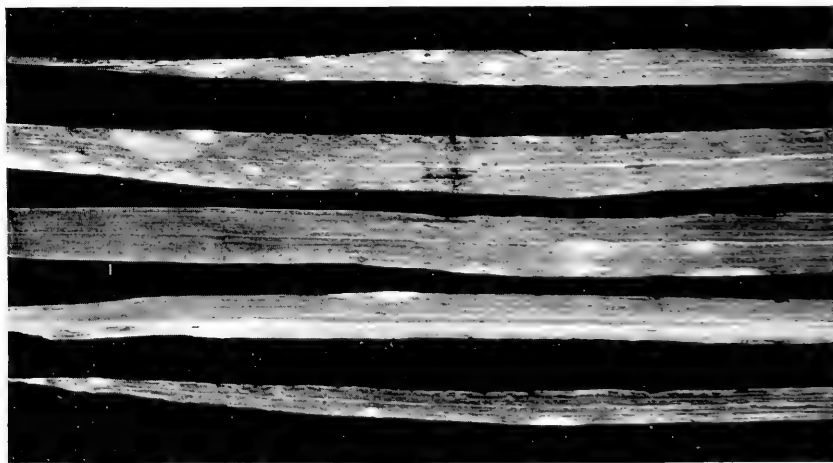

Fig. 21.—Halo blight of oats. Bacterial infection of oats leaves results in the appearance of yellow-green, oval spots surrounded by clear, translucent halos.

epidemic disease, being present every year but fluctuating both in prevalence and intensity from year to year in conformity with prevailing weather.

In 13 years of record, it has varied in prevalence from about 1 per cent to 68 per cent and in destructiveness to leaf tissue from a trace to 13.6 per cent. Although adequate estimates of the losses resulting from halo blight attack have not been made, the destructiveness of the disease is known to be great in years of severe attack.

**Control.**—Since halo blight infection is carried on the oats seed, seed treatment is one measure of control. Tests have shown that soaking seed for 2½ hours in a solution of formaldehyde, 1 pint to 40 gallons of water, will materially reduce the number of living bacteria. Treating the seed with air heated to 212 degrees F. for 30 hours will destroy all seed-borne infection. Field sanitation and crop rotation are important in reducing the infection present in the soil and crop refuse. In any area in which losses are heavy, resistant varieties may be useful. Over 40 varieties of cultivated oats have been tested and found susceptible to halo blight, but the degree of susceptibility varies greatly. Wisconsin No. 14 was found the most susceptible, while Wisconsin Nos. 13 and 15 showed considerable resistance under similar conditions. These varieties have not been tested under Illinois conditions.

## HELMINTHOSPORIUM LEAF SPOT

### *Helminthosporium Avenae*

The Helminthosporium leaf spot is one of two leaf spots important on oats in Illinois. Oats are the only cereal it attacks; both leaves and seed become diseased.

**Appearance.**—Since Helminthosporium leaf spot is seed-borne, the irregular to oval, reddish-brown spots characteristic of the disease begin to appear on the seedling leaves soon after they emerge, fig. 22. Spores of the fungus produced in dead areas in the center of these spots are carried to other leaves, where they cause new infections. Spots on stem leaves may be long and narrow or broad and irregular. The outer edges of the spots often are poorly defined, the brown merging gradually into the yellow or reddish shades which frequently spread over the greater part of an infected blade. Sometimes invasion by the fungus does not produce well-defined spots but instead causes

the leaf to assume a withered appearance, as if injured by adverse weather conditions. As the badly diseased leaves die, they change from green to pale yellow or gray, and the brown of the diseased spots fades. The oats head sometimes becomes infected. Then

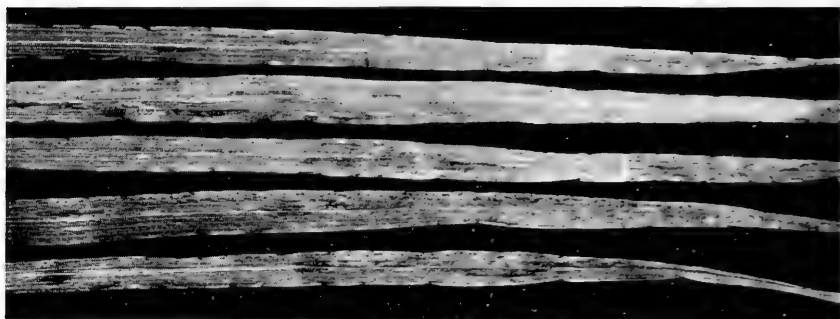

Fig. 22.—*Helminthosporium* leaf spot of oats. Leaf infection by *Helminthosporium* causes dying of narrow, oblong strips of leaf tissue between veins. The dead tissues turn rusty brown.

the fungus enters the hull surrounding the kernel and may even penetrate the kernel itself. An attacked kernel turns brown at the basal end.

**Life History.**—The fungus causing *Helminthosporium* leaf spot overwinters as spores on the outside of the seed and as mycelium within the seed. When infected kernels sprout, the fungus within the seed renews its growth, or the spores on the seed germinate and produce infected spots on the seedling leaves. Spores produced in these spots are dispersed by various means to other leaves of the same plant, as well as to other plants, and produce new spots. Successive crops of spores borne on both old and new spots provide an abundance of infective material for new leaves as they form and for the grain as it develops.

**Importance.**—Diseased plants, because of the destruction of leaf tissue, are handicapped in the manufacture of food substances, and the reduction in food results in light or shriveled kernels, as does also direct attack of the disease on the kernels. *Helminthosporium* leaf spot is present every year in Illinois oats fields, but usually the loss due to it is slight. It fluctuates from year to year both in prevalence and in severity of attack, and in Illinois fields has ranged in prevalence from 15 per cent to as high as 75 per cent, with a corresponding destruction of leaf area ranging from 0.4 to 6.4 per cent. Data extending back to

1928 indicate that, as an annual average, 36 per cent of the oats plants grown in the state are infected and that this infection destroys nearly 2 per cent of the oats leaf area.

**Control.**—Seed treatment tends to reduce the amount of infective material borne by the seed but will not kill all the fungous growth in kernels. Thorough fanning removes many of the light, shriveled and heavily infected seeds. Unless the disease is very severe, the ordinary seed treatment recommended for oats will give satisfactory results.

## SCAB

*Gibberella Saubinetii*

The scab disease that attacks oats is identical with the one that attacks wheat, barley and rye, but oats is the least susceptible of the cereal crops. The disease attacks the head as the plant matures and the seedlings as they emerge. In the latter case, it is often known as *Fusarium* blight.

**Appearance.**—The symptoms of scab on oats are in general the same as on wheat. The disease is not, however, as readily detected on oats as it is on wheat, because the oats kernel is covered by a hull. The hulls of infected spikelets are ashen gray and may be partially covered by a pink mold; in severe cases they are shriveled and rough in appearance, fig. 23. The hulls do not turn brown. Seedlings from infected seed are stunted and often turn yellow and die. If seed is badly diseased, the young plants may be killed before reaching the surface of the ground. Roots of scab-infected seedlings are apt to be rotted and to be reddish brown in color; late in the season they may be covered by the pink mold characteristic of the disease.

**Life History.**—On oats the life history of the scab fungus is identical with that given on page 30. However, the natural resistance of most oats varieties and the lateness of the oats crop, which usually enables it to escape infection, prevent multiplication of the scab fungus in oats fields at the rapid rate possible in wheat fields. Consequently, oats planted on old corn land serve as a buffer crop, exhausting the scab infection carried by the corn refuse and thus protecting the wheat which is to follow.

**Importance.**—While oats scab can usually be found every season in every county of the state, it does not cause serious reductions in yield. The percentage of infected plants per field is almost always very low, and there is usually only one, or a few,



Fig. 23.—Scab on oats. The white spikelets are diseased, the darker ones healthy.

diseased spikelets per head. The loss from seedling blight due to the scab disease is very small. Control measures are given on page 31 under the disease as it occurs on wheat.

### ANTHRACNOSE

*Colletotrichum cereale*

Anthracnose of oats is the same disease as anthracnose of wheat and rye. While it is relatively rare on oats, samples of it have been collected in 23 Illinois counties. Although diseased



plants are usually overlooked by the grower, a slight reduction in yield is caused by the disease. It is described in detail on page 31, and the measures recommended there will be found useful for its control in oats.

## LOOSE SMUT

*Ustilago Avenae*

Loose smut is sometimes called naked smut and black heads. It is the most conspicuous disease present in Illinois oats fields, and it attacks no other cereal crop. Oats varieties differ in susceptibility to attack.

**Appearance.**—As the infected oats head emerges from its inclosing sheath, it presents a brown-black mass of powder which has replaced the chaff and grain of each spikelet, fig. 24. The smut masses of each spikelet may be surrounded by a delicate, white membrane, but this soon breaks and liberates the



Fig. 24.—Loose smut of oats. Usually, though not always, the spikelets of diseased heads are entirely transformed into black powder, which consists of the spores by which the smut fungus is spread.

black, sooty powder, each grain of which is a fungous spore. Diseased panicles do not spread as much as healthy heads heavy with developing grain. Usually all the heads on an infected plant are smutted, but sometimes one or two are normal. Generally, too, all the spikelets of a panicle are diseased, but occasionally the upper ones remain healthy. Diseased plants cannot be told from healthy ones before heading out, and they are often overlooked at harvest because they are shorter than healthy plants and by that time have lost their black masses of spores.

**Life History.**—The spores produced on diseased heads are dispersed chiefly by the wind. Many of them lodge on healthy heads, either on the chaff or between the chaff and the young kernel. Some of these spores germinate immediately, growing into the hull or into the seed coat of the kernel and remaining inactive there until the seed is sown the following year. Other spores do not germinate immediately but remain on the seed, in the groove or between the seed and the hull, until the seed is sown. In any case, after the oats are sown, the fungus grows into and infects the young oats shoot before it is very old. The young plant is not susceptible to infection after its first leaves have emerged three-eighths inch beyond their sheath. In an infected plant the smut fungus grows up with the growing tip and by heading time has replaced the oats spikelets with black masses of spores. These in turn, when shed, lodge on healthy heads, infecting the seed to be used the next year.

**Importance.**—Loose smut is one of the most important oats diseases. In individual fields infection may be so heavy that over 25 per cent of the plants are smutted. Usually, however, it is much less than this. For Illinois as a whole, the infection has ranged from 1 per cent to 6.5 per cent in different years. Data for 11 years indicate an average annual infection of 3.6 per cent, representing a reduction in yield equivalent to 4,302,000 bushels annually.

**Control.**—Loose smut, even though it is carried within the hull or the seed coat, can be controlled without resort to the hot water method. Formaldehyde, *Smuttox* and organic mercury compounds, if properly used, will give practical control. The use of resistant varieties, such as Markton, Nevarro, Bond and Victoria, will also help reduce smut losses. Marion, Hancock and Boone, new varieties just being released, are resistant to loose smut, as well as crown and stem rust, and are suitable for Illinois conditions.

Sowing oats early in a well-prepared seed bed helps the

young plants to reach quickly the stage of non-susceptibility. A warm, wet soil is very detrimental to growth of the fungus. The "dry" formaldehyde treatment gives excellent control if it is applied carefully, but when carelessly applied gives poor control or causes serious injury to the seed. For hullless oats, which are very easily injured by formaldehyde, organic mercury dusts, *Smuttox* and copper carbonate will be more satisfactory. The mercury compounds are more expensive than formaldehyde but are not likely to injure the seed.

## COVERED SMUT

### *Ustilago laevis*

Covered smut is so similar to loose smut that to distinguish between the two as they occur in oats fields is often very difficult. Certain identification often requires microscopic examination of the spores. Both smuts attack oats, but no other cereals.

**Appearance.**—Although it eventually becomes very similar to loose smut, covered smut often can be clearly distinguished early in the season. Except that they do not spread widely, heads infected with covered smut appear almost normal when they emerge from the boot. The chaff, not greatly affected at this time, retains within it the grains that have been transformed into smut masses, fig. 25. As the oats plants mature, the chaff dries and tends to disintegrate, exposing the transformed seed, which is incased in a thin, grayish-white, persistent membrane. This membrane, unless broken by accident, continues to cover the smut mass until harvest, thus giving the disease its name.

**Life History.**—The smut masses not broken in the field are shattered in harvesting and threshing, and the spores of which they are composed are set free. Many spores lodge on healthy grains, and those that are wedged inside the hulls germinate immediately or during the time the grain is stored. After germination of the spores, the fungus invades the seed coat, where it lies dormant until the seed is planted and begins to grow. Then the fungus renews its growth, invades the seedling and grows with the seedling, finally invading the head and transforming the grain into new smut masses.

**Importance.**—Covered smut is not as abundant as loose smut in Illinois oats fields. But, because of the difficulty in distinguishing the two, there is no doubt that the losses attributed to loose smut are due in part to covered smut. The relative importance



Fig. 25.—Covered smut of oats. The oats kernel is transformed into a mass of black powder, but the glumes remain more or less intact until the oats crop is nearly mature.

of the two oats smuts has never been determined, but the average annual loss of over 5 million bushels from both smuts fully justifies the use of effective treatments.

**Control.**—Control measures required for covered smut are the same as those for loose smut. For hulled oats the “dry” formaldehyde treatment (page 124), when carefully used, is most satisfactory, and for hullless oats copper carbonate dust (page

122) gives good results, while eliminating the danger of seed injury. Other treatments suggested for loose smut may be used also. The universal prevalence of both loose and covered smut in Illinois oats fields is, in itself, a recommendation for the universal use of preventive seed treatments.

## BLAST

*(Cause unknown)*

Blast, or sterility, of oats is a disease the cause of which is not known. No parasitic organism has been proved to cause it, but weather conditions, especially temperature and moisture,



Fig. 26.—Oats blast. On the two heads at the right, many spikelets are blasted; on the head at the left only a few blasted spikelets can be seen.

previous to heading appear to play an important part in determining the amount of blast, while the inheritance of sterility characters may also determine the presence or absence of the disease.

**Appearance.**—As the name of the disease suggests, spikelets that normally should bear grain are blasted and fail to develop, fig. 26. These spikelets can be recognized, as soon as the head emerges from the boot, by their light color and delicate texture, as well as by the fact that they contain no rudiments of grain. Usually only a few spikelets on the lower half of the head are blasted, but occasionally half and rarely the entire head is sterile. Some blasted spikelets are so small as to be almost unnoticeable at maturity, but others are nearly normal in size and are recognizable chiefly by their pale yellow to white, paper-like chaff.

**Importance.**—Blasting of oats spikelets results in a direct reduction in yield proportional to the amount of blast that is present. Fourteen years of observations in Illinois oats fields indicate prevalences ranging from 32 to 88 per cent with accompanying losses of 6 to 21 per cent, and with an average for that period of years of 68.2 per cent prevalence and 13.8 per cent annual loss.

**Control.**—There are no control measures to recommend. The amount of blast varies from year to year. Oats varieties apparently do not exhibit special degrees of resistance or susceptibility to this disease.

## ERGOT

*Claviceps purpurea*

Ergot, described on page 106 as a rye disease, has been reported to attack oats, but this attack occurs so rarely that there is no record of it in Illinois. Of the small grains, oats are the least susceptible to ergot, and control measures are not required.

## POWDERY MILDEW

*Erysiphe graminis*

Powdery mildew, though relatively common on wheat, has not been found on oats in Illinois. A specialized race of the powdery mildew fungus is necessary for infection of oats; it produces the characteristic appearance described on page 50.

## IV

### *Barley Diseases*

The acreage devoted to barley in Illinois, compared with that devoted to wheat and oats, is not great and varies considerably from year to year. As a cereal crop, barley holds a minor position, and its diseases have not received the attention, either as to their importance or their control, accorded those of more important crops.

Barley diseases include a number that are common to all cereals, namely, stem rust, anthracnose, powdery mildew, ergot and scab; and one, spot blotch, that occurs also on wheat. Diseases peculiar to barley are its leaf rust, its two smuts, a bacterial blight, net blotch and the very destructive stripe disease.

Losses or crop reductions attributable to barley diseases have never been carefully estimated to include all diseases. But, in nine years, beginning with 1926, reductions in yield due to

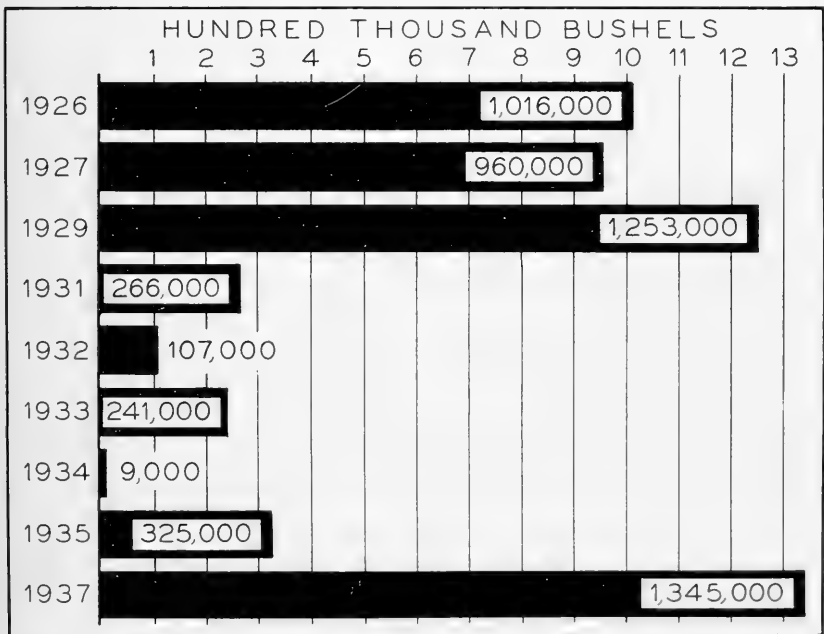

Fig. 27.—Reductions in Illinois barley yields due to disease, based on estimates available for the period 1926-1937.

stripe, the rusts and the smut diseases have been estimated at 5,522,000 bushels, an average annual loss of 613,500 bushels. (See fig. 27.)

#### DIAGNOSTIC KEY FOR BARLEY DISEASES

1. Roots diseased and rotted..... 2  
Aboveground parts diseased..... 3
2. Roots reddish brown, often covered with gray or pink mold..... Scab, p. 88  
Roots with many brown spots, never moldy..... Spot blotch, p. 84
3. Heads diseased..... 4  
Disease apparent chiefly on leaves or stems..... 9
4. Heads transformed to black, powdery masses..... 5  
Head structures normal..... 6
5. Powdery masses breaking open and dispersing soon after appearing..... Loose smut, p. 90  
Powdery masses inclosed in a grayish membrane for some time..... Covered smut, p. 92
6. Heads white, prematurely ripened..... Anthracnose, p. 90  
Heads brown or green..... 7
7. Kernels transformed into large galls..... Ergot, p. 95  
Kernels normal or shriveled..... 8
8. Chaff brown, spikelets blighted, kernels shriveled..... Scab, p. 88  
Chaff only brown spotted, spikelets normal, kernels normal..... Net blotch, p. 85
9. Disease symptoms apparent chiefly on the stems..... 10  
Disease symptoms most obvious on the leaves..... 11
10. Brick-red or black pustules with ragged margins present..... Black stem rust, p. 78  
Purplish or water-soaked blotches on the lower joints, dead leaf sheaths covered with minute black specks..... Anthracnose, p. 90
11. Leaves bearing small, oval, yellowish pustules..... Leaf rust, p. 77  
Leaves spotted or streaked..... 12
12. Spots on the leaves indefinite, covered by a superficial, floury appearing fungous growth..... Powdery mildew, p. 94  
Spots on the leaves well defined, without a superficial fungous growth..... 13
13. Leaves with one or more long, brown stripes..... Stripe, p. 79  
Leaves brown spotted or with short brown streaks..... 14
14. Spots minute, dark brown, usually very numerous, not obviously injurious to the leaf... Non-parasitic brown spot, p. 87  
Spots larger, dark brown or yellow green, few per leaf, obviously injurious..... 15
15. Spots oblong and dark brown, netted..... Net blotch, p. 85  
Spots long and narrow, not netted..... 16
16. Spots uniformly yellow green to brown, and translucent..... Bacterial blight, p. 82  
Spots with dark brown centers and faded edges, not translucent..... Spot blotch, p. 84



## LEAF RUST

*Puccinia anomala*

Leaf rust of barley, also called dwarf leaf rust, not usually a serious disease in Illinois, attacks only barley, on which it has the same relation to other barley diseases as the leaf rust of wheat has to other diseases of that crop.

**Appearance.**—Leaf rust appears first as small, oval, light yellow pustules scattered irregularly on either surface of the leaf, fig. 28. Infection occurs late, and the rust pustules seldom are seen much before the plants begin to head. In its attack it is confined to the leaves, stems and chaff. A winter pustule stage is produced as the plant nears maturity, and the pustules, slate gray in color, tend to run together, forming gray patches.

**Life History.**—The life history of the barley leaf rust fungus is similar to that of other cereal rusts. Both summer spores and winter spores are produced, but spread of infection from field to field and development of the annual epidemics apparently depend entirely on the summer spores. In Europe, an alternate host, star of Bethlehem, is subject to infection from winter spores, but in America the rust never has been reported on this or related hosts. In all probability the fungus is able to live through the winter on volunteer and winter-sown barley, and the summer spores may survive winter conditions in southern parts of Illinois.



Fig. 28.—Leaf rust of barley. The rust pustules are to be seen above as small, black dots scattered over the leaves. The larger dots are the open summer-spore pustules and the smaller, gray dots are the covered winter-spore pustules.

**Importance.**—Leaf rust appears on barley every season and attacks the crop wherever it is planted in Illinois. Its attack comes late, however, and seldom becomes general in southern Illinois earlier than June 15, in central Illinois earlier than June 22 and in northern Illinois earlier than July 10. The average annual prevalence of leaf rust, as shown by direct field counts, is such as to affect 67.2 per cent of the barley plants, and the intensity of the attack causes an average annual reduction in leaf area of 5.1 per cent. These figures indicate that over a period of years leaf rust of barley is relatively an unimportant disease. Yet it behaves in the same manner as other epidemic diseases, fluctuating with the weather from year to year. It has had prevalences as high as 100 per cent and as low as 23 per cent, and intensities reducing leaf area by 8.3 per cent and 0.3 per cent. Hence, in some years, it may be an important factor in determining barley yields.

**Control.**—Control measures for this rust do not exist, but the present relative unimportance of the disease makes them unnecessary.

## BLACK STEM RUST

*Puccinia graminis*

Barley, in common with other small grains, is subject to attack by black stem rust. The rust parasite, as stated on page 20, has developed specialized races adapted to particular crops, but for barley there is no such specialized race. Instead, barley infection is brought about by races especially adapted to wheat, rye and perhaps also timothy.

**Appearance.**—Black stem rust on barley occurs chiefly on stems and leaf sheaths. Early season infections break out as brick-red pustules with ragged edges, very similar to those shown for wheat in fig. 6. This red rust stage is succeeded by the black rust stage, in which the color of the pustules changes to black.

**Life History.**—The life cycle of the black stem rust fungus, given in detail on page 21, on barley begins with infection of the plant as it develops. First to appear are the red rust pustules, which produce summer spores active in spreading the rust during the growing season. As barley matures, a black rust stage appears, in which dark colored resting spores are produced. These spores overwinter and germinate in the spring, producing immediately a third type of spore, very minute and short lived, that is capable of infecting common barberry bushes. A cluster

cup stage formed on the barberry produces spores capable of infecting barley and other grains, and at this point the new season's epidemic should begin. However, the presence of the rust in regions lacking barberries indicates that the first infections may be initiated by summer spores blown northward from regions warm enough for them to live over winter or blown from near-by wheat and rye fields already infected.

**Importance.**—In Illinois the black stem rust attack on barley varies greatly from year to year, both in number of plants attacked and in injury done to the stems. In general, the disease is of very little importance in the southern half of the state, but northward it is responsible for reductions in yield ranging up to 0.5 per cent. By harvest, stem rust infection can be found, as a rule, on every stem in northern Illinois barley fields, but the attack is so light that functioning of stem tissues is not hampered, except in years such as 1926 and 1927, when 30 per cent and 18 per cent of the area of barley stems was occupied by rust pustules.

**Control.**—General measures for black stem rust control, given in detail on page 24, include eradication of the common barberry to avoid local epidemics and the use of early maturing barley varieties.

## STRIPE

*Helminthosporium gramineum*

The destructive disease known as stripe, sometimes called blight, attacks only barley. It is a systemic infection and affects the entire plant. There are at least 20 specialized races of the fungus that causes the disease.

**Appearance.**—The earliest evidence of stripe infection, small, yellow spots on the leaves of seedlings, is usually overlooked. But, some weeks before heading, conspicuous and characteristic symptoms appear. These consist of narrow, yellowish to straw-colored, longitudinal streaks or stripes in the blade of the leaf. There may be one or several such stripes, running parallel with each other and extending the entire length of the blade. At this stage, the variegation of pale yellow and green of diseased leaves contrasts sharply with the uniform green of healthy leaves. The light yellow stripes soon change to reddish or dark brown along the margin, the center remaining a lighter brown, and the diseased tissue dies and usually splits longitudinally in the lighter colored area, fig. 29.

Affected plants usually are severely stunted, few reaching half the height of healthy plants. Heads generally fail to emerge:

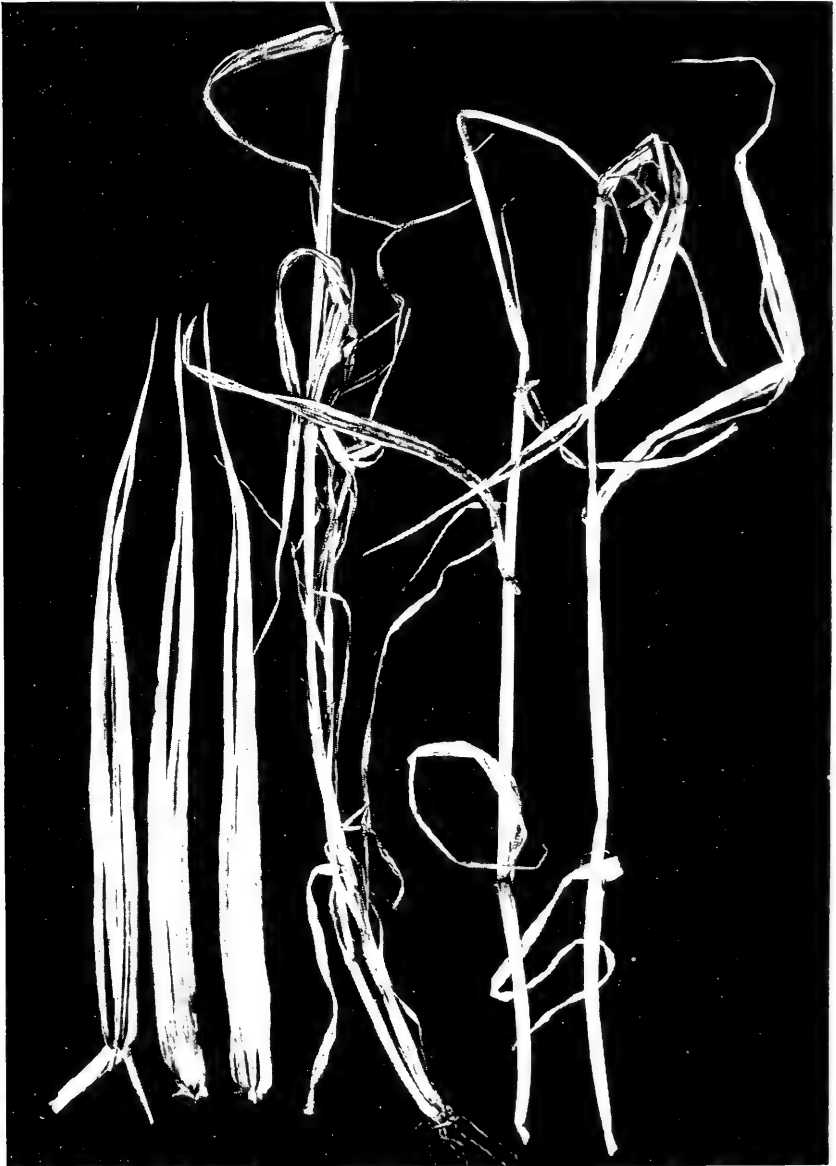

Fig. 29.—Barley stripe. The fungus kills strips of tissue between the leaf veins, and leaves split and shred along these strips. Infected plants are stunted and usually die before they head.

those that do are grayish brown, withered and barren. All the stems of a diseased plant are affected; such a plant dies prematurely and shrivels up so as to be inconspicuous by harvest time.

**Life History.**—Summer spores of the stripe fungus are produced in the dark stripes on the barley leaves. These spores are carried by air currents, wind or other agencies to the heads of healthy plants. Spores lodging near the bearded end of the chaff germinate, under favorable conditions, and produce a fungous growth which develops between the hull and the seed or even penetrates the seed coats of the grain. This fungous growth, associated with the seed in a resting or dormant state, is the chief means of carrying the disease over from one year to another. The head is susceptible to infection over a considerable period of time. A winter spore stage of the stripe fungus which has been found is known to be able to cause infection, but it generally is thought to be unimportant in maintaining the disease.

Upon germination of the barley seed the fungus resumes its active state, grows first into the sheath which surrounds the seedling leaves, then into the first leaf and from it into the next leaf. This process goes on until all leaves of the plant are infected. If the fungus invades the growing point of the stem, death of the plant results. The spores of the fungus are able to remain viable for as long as 34 months, and the fungus itself has been known to remain alive five years in the seed.

**Importance.**—Barley stripe is more important than the grower normally thinks, for the reason that many diseased plants are overlooked at harvest. It is, as a matter of fact, one of the most destructive barley diseases. Yearly observations of its prevalence in Illinois barley fields show a range from about 2 to 9 per cent of infected plants for the state as a whole, with infections in individual fields ranging from a trace to as high as 21 per cent and infections of 10 to 15 per cent by no means rare. Data taken in eight different seasons indicate an average annual loss of 3.7 per cent from stripe in Illinois barley fields.

**Control.**—Since the stripe fungus does not often invade the tissues of the barley seed, it can be controlled adequately by methods other than the hot water seed treatment. *Ceresan* and other organic mercury compounds are satisfactory, and of course the use of seed from disease-free fields results in an absence of stripe. Sowing seed when the soil is warm (68 degrees F. or

above) and wet (90 per cent saturated) will reduce the amount of disease, since the stripe fungus does not thrive in hot, wet soil. Resistant varieties of barley also offer a promising means of reducing loss. Wisconsin No. 38, known as Wisconsin Barbless, is highly resistant. Other resistant varieties are Spartan, Nepal and Black Hulless, while Lion and Glabron are moderately resistant. Of these, Spartan is the only variety grown extensively in Illinois. The Oderbrucker variety is very susceptible, as are also Minsturdi, Manchuria, Velvet and Peatland.

## BACTERIAL BLIGHT

### *Bacterium translucens*

Bacterial blight of barley is chiefly a leaf disease, but it attacks the chaff and stems, also. Although this bacterial blight attacks none of the other cereals, a very similar disease of rye (page 101) and the black chaff disease of wheat (page 45) are caused by specialized strains of the same parasite. The bacterium attacks all types of barley without apparent preference, but some degree of resistance is exhibited by certain varieties of this grain.

**Appearance.**—Bacterial blight, fig. 30, is characterized by small, water-soaked spots that occur on tender green leaves of barley plants and sometimes on leaves of seedlings. These spots enlarge, usually longitudinally, causing translucent stripes of various lengths, which turn yellowish to brownish. They may extend the entire length of a leaf but are very narrow, seeming

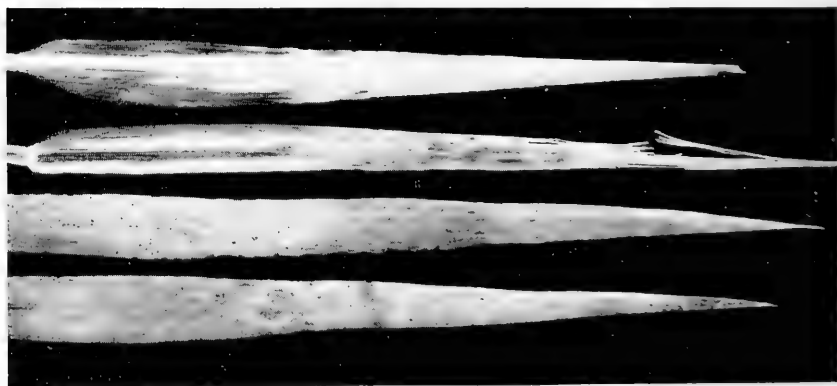

Fig. 30.—Bacterial blight of barley. Infection of barley leaves results in the production of translucent stripes of various sizes which may become covered with small yellow granules of dried bacterial ooze.

to be limited by the leaf veins. Occasionally enlargement of the original spot is blotchlike, and this may cause much of the leaf to shrivel and turn light brown. Infected tissue gradually changes from healthy green through translucent yellow to brown. Translucency, even of brown spots, is a fairly constant and distinctive characteristic of the disease. Ordinarily the disease does not attract attention until plants are two-thirds grown. Under humid conditions, especially early in the morning, droplets of milky bacterial exudate may be seen on either surface of diseased spots. These droplets dry into hard, yellowish, resinous granules, which may be removed easily as dry flakes from the leaf surface. The disease produces water-soaked areas on the chaff of the barley head similar to those on the leaf except that the bacterial exudate is not as plentiful. Spotting of the chaff does not destroy the grain, which, however, may be brown and shrunken, and may carry the disease to next year's crop. In case severe infection of the flag leaf occurs, the head may be unable to emerge from the sealed boot and then may break through the side of the sheath. When this happens, the head is apt to be distorted and partially blighted.

An easy method of diagnosing bacterial blight is as follows: If a leaf showing a freshly developed stripe is cut in two pieces crosswise, either piece squeezed between the fingers will exude a bead of milky ooze at the cut edge. From a leaf showing older spots, the exudate has the consistency of cream and hardens quickly into a yellowish, resinous mass.

**Life History.**—The barley blight bacterium reproduces in the manner customary to bacteria (see page 6). It is able to live on stored grain for two years and overwinters in dry, blighted leaves. Initial infections come probably from bacteria carried on the seed rather than from those in the soil, and spread of the disease from leaf to leaf and plant to plant is brought about largely by water, dashing rain and dripping dew, although insects may play some part in spreading the bacteria. In this disease, infection occurs through the stomata present on leaves, stems and chaff.

**Importance.**—Bacterial blight, though chiefly a midwestern disease, does very little damage in Illinois. Although in certain years, such as 1928, the percentage of infected barley plants may be as high as 90 to 100 per cent, the destruction of leaf area is generally negligible, and practically no reduction in yield results from the attack.

**Control.**—The barley blight bacteria cannot be prevented from spreading from plant to plant after the disease has become established in a field. Under Illinois conditions, if the use of seed from diseased fields is avoided very little difficulty from bacterial blight will be experienced. When the cleanliness of seed is doubtful, the presoak method of seed treatment with formaldehyde, mercuric chloride or other fungicides (page 118) should destroy bacteria borne on the surface of the seed.

## SPOT BLOTCH

*Helminthosporium sativum*

The spot blotch disease of barley, though somewhat different in appearance from the *Helminthosporium* disease of wheat (page 33) is caused by the same parasite. On barley, the disease is more conspicuous on the leaves than on other parts of the plant.

**Appearance.**—First signs of the spot blotch disease appear on barley seedlings as chocolate-brown areas on the sheath and blade of the first leaf, which may turn yellow and die. Roots of

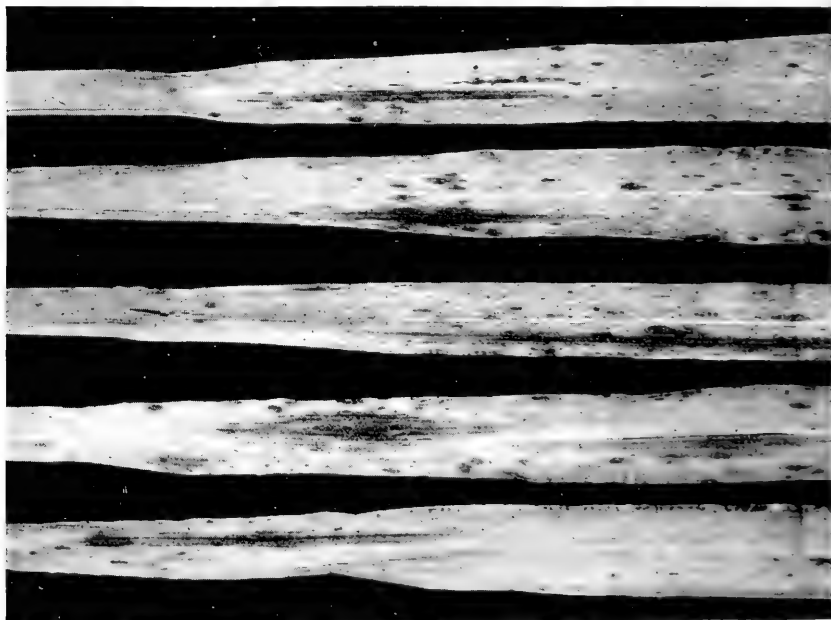

Fig. 31.—Spot blotch of barley. This disease appears on upper leaves about heading time as long, narrow spots, which are brown in the center but merge gradually into the normal green of the leaf.



diseased plants may show signs of rotting and have many brown lesions or spots on them. In severe cases seedlings are killed, and poor stands result.

On barley plants that escape serious seedling infection, the disease is not very noticeable until about heading time. Then characteristic spots about half an inch long and an eighth inch wide appear on the leaves, fig. 31. The center of each spot is dark brown, and this color gradually merges toward the edge into the normal green of the leaf. Spot blotch lesions never have the netted appearance characteristic of the net blotch disease. Rotting of roots and death of leaves causes premature ripening of plants with spot blotch. The disease starts on old leaves and spreads to younger leaves. Heads also may become infected, and dark brown spots then appear on the chaff and at the germ end of diseased kernels.

**Importance.**—While spot blotch has been reported in many Illinois localities, its importance has not been carefully evaluated. In other states where barley is grown more extensively than in Illinois, annual losses attributable to spot blotch are estimated to range from 1 to 3 per cent. Undoubtedly similar losses occur in Illinois.

**Control.**—The life cycle of the spot blotch parasite is the same on barley as on wheat. Hence the control methods advised for wheat on page 36 apply equally well to barley.

## NET BLOTCH

*Pyrenophora teres*

Net blotch of barley is a leaf disease of the kind generally known as leaf spot, in which the spots are marked internally with a characteristic netting. The netted pattern, formed by the arrangement of brown pigment in transverse and longitudinal lines, can best be seen if the leaf is held against the light. Barley is the only crop attacked by this disease; leaves, stems and seeds are affected.

**Appearance.**—Spots of net blotch on barley leaves are very similar to those of spot blotch but are distinguished by the irregular distribution of brown pigment, which gives them a cross-hatched appearance, fig. 32. Net blotch may be seen first on seedling leaves as small, more or less circular to oblong, dark brown spots. These spots may increase in length and form short, narrow streaks; as they enlarge the netting becomes visible.

Upon aging, their color fades from dark brown to brownish gray, because of spores formed by the net blotch fungus. From these spores, new infections arise on other leaves, other plants and finally on the grain. Some of the spots are blotchlike and have

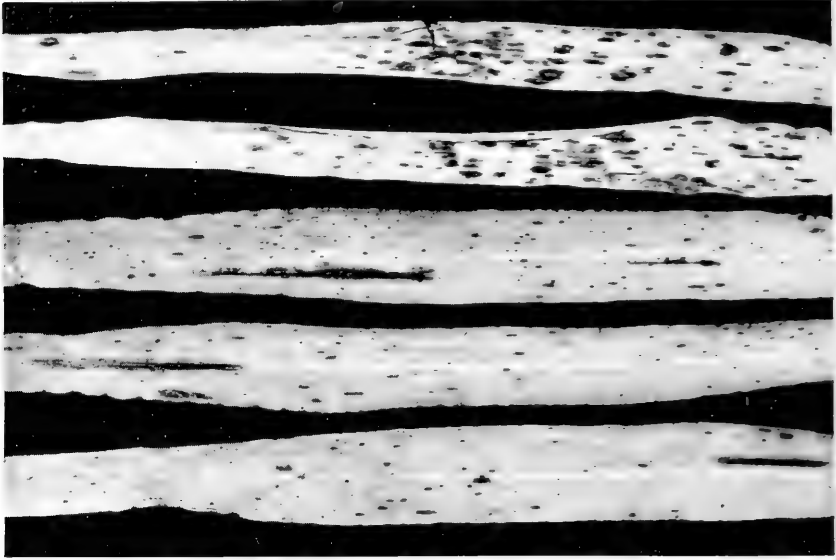

Fig. 32.—Net blotch of barley. The outstanding characteristic of net blotch is a netted appearance in the spots, due to uneven distribution of brown color.

yellow edges, and the leaf tissue surrounding them is often somewhat yellowish. Streaks caused by this disease can be distinguished from those of the stripe disease, since the former are much shorter and the leaf tissue does not split or shred along them. At harvest the straw of diseased plants is dull brown and weak. Infected kernels bear dark spots at the base.

**Life History.**—The net blotch fungus produces both winter and summer spores. The summer spores are borne in abundance on the surface of leaf spots, where they may be seen as a grayish powder. Scattered by wind, water and other means, they infect leaves and plants. Successive crops of spores are formed during the growing season. Those spores falling upon the chaff may germinate and infect the grain. Once the fungus gets into the hull, it remains dormant throughout the season but renews its growth when the seed is sown. This results in direct infection of the seedling and the formation of spots on seedling leaves.

The winter spores are produced in very small, dark, flattened,

flask-shaped bodies partially embedded in old infected straw and stubble. In the spring, when weather conditions are right, these winter spores are discharged into the air and carried by the wind to the new crop. Not only does net blotch overwinter by these methods; it produces summer spores on special outgrowths from the winter fruiting bodies. What relative importance these different spores have in producing the disease is not definitely known, but in all probability infected seed is the most important means of perpetuating the disease.

**Importance.**—In Illinois, net blotch is probably the least important of the epidemic diseases of barley. It causes a slight reduction in leaf area on diseased plants and injures the grain to some extent. Very rarely, as in 1930 when over 75 per cent of the plants examined in fields were diseased, it achieves great prevalence, but even then only a trace of leaf area is destroyed.

**Control.**—Methods of control given for barley stripe on page 81 apply to net blotch, except that in the latter disease seed treatment is not as effective as in the case of stripe. Since the fungus of net blotch lives through the winter within the seed and on old straw and stubble, control is more difficult in this disease than in either stripe or spot blotch.

## NON-PARASITIC BROWN SPOT

*(Cause unknown)*

Non-parasitic brown spot of barley is a disease for which, thus far, no cause has been found. As the name implies, a brown spotting of the leaves occurs, which may be attributed to the physiological condition of the plant, to its environment or to some inherent characteristic.

**Appearance.**—The non-parasitic brown spot disease appears as numerous minute, dark brown, short, narrow and more or less rectangular areas on the barley leaf, fig. 33. Spots are scattered irregularly over the leaf and are visible on either surface. They are limited at the side by veins, and at the ends they may be sharply limited or may fade gradually into the normal green of the leaf. They vary in length but are seldom more than an eighth inch long; the smallest spots appear almost circular. Occasionally spots coalesce, forming elongated streaks or irregular blotches.

**Importance.**—Although non-parasitic brown spot occurs on barley throughout Illinois, it has been observed most abundantly in the northern counties. Field counts indicate that the proportion

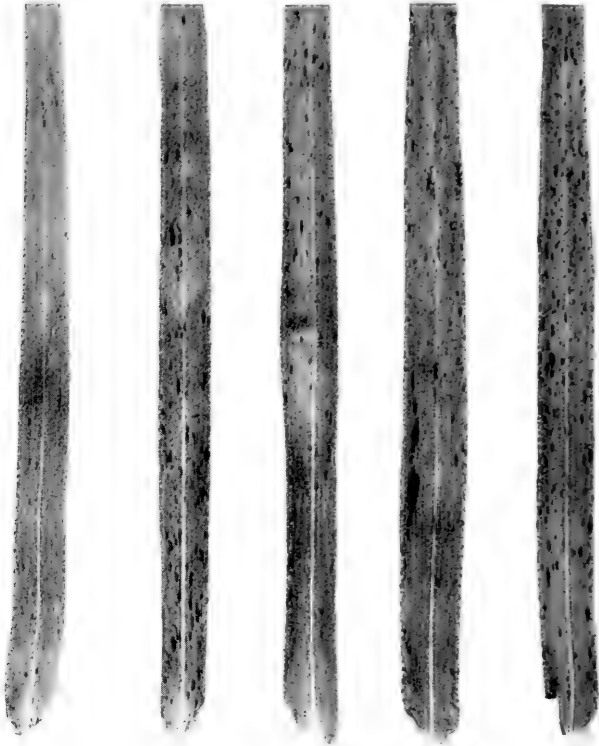

Fig. 33.—Non-parasitic brown spot of barley. Affected leaves become spotted in varying degrees by tiny, oval spots of a distinctive brown.

of diseased plants varies from 15 to 100 per cent in different fields. Injury by the disease results from the reduction of useful leaf area. In Illinois fields, injury appears thus far to have been very slight.

**Control.**—No control measures for this disease are known.

## SCAB

*Gibberella Saubinetii*

Scab of barley, called also *Fusarium* head blight, is the same disease as the scab of wheat and other small grains. Barley ranks second to wheat in susceptibility. Standard barley varieties show less difference in resistance to the disease than wheat varieties.

**Appearance.**—The characteristics of scab as it appears on barley, fig. 34, are very similar to those given for wheat scab on

page 28, but the disease is not as conspicuous on barley as it is on wheat, because the grain is covered by a hull, and diseased barley spikelets are brownish instead of white. Infected barley hulls change to a light brown and later become dusty gray, the light brown color showing first at the base of the hull. Kernels of infected spikelets often turn brown at the base, and in the more severe cases the entire kernel may become brown. Badly scabbed kernels of barley have much the same appearance as scabby wheat kernels. When infection takes place late, the hulls may show the brown color only at the base, or the surface of the hulls may become rough and gray colored at the base. Diseased kernels, if examined closely, reveal the grayish, shriveled, scabby condition typical of the disease.

**Life History.**—Details of the complicated life history of the scab fungus as a wheat parasite, given on page 30, do not differ from those of its history when it attacks barley.

**Importance.**—Scab occurs on barley in all parts of the state. In certain years, such as 1928, it causes considerable reductions in



Fig. 34.—Scab on barley. The four heads in the center show the effect of scab attack. Normal heads are at either end of the row.

yield. Heavily infected grain may be refused by stock as food. If more than 10 per cent of the kernels are scabby, barley cannot be used profitably for hog feeding but may be used for cattle, sheep and poultry feeding without harmful effects.

**Control.**—Scab control measures advised on page 31 for wheat are applicable also for barley. Use of resistant varieties offers some hope for controlling the disease, although the difference in resistance shown by standard barley varieties is not great. In cornfields to be sown to barley, cutting the stalks and removing them for feed, as well as carefully plowing the field to cover all corn refuse, tends to check the epidemic occurrence of the disease.

## ANTHRACNOSE

*Colletotrichum cereale*

Anthracnose attacks all parts of the barley plant, just as it attacks wheat, oats, rye and numerous wild grasses. While it is rather inconspicuous and not very common on barley in Illinois, it can be recognized from the description given under wheat diseases on page 31.

## LOOSE SMUT

*Ustilago nuda*

Loose smut of barley destroys the head of the plant. Black heads, black smut and smut are other names often applied to the disease. Although very similar in appearance to the loose smuts of other cereals, this disease does not attack any grain other than barley.

**Appearance.**—The disease first becomes evident as the head emerges from the boot, which occurs at about the same time in diseased plants as in healthy plants. The normal chaff and rudimentary grain of diseased heads are replaced by a mass of olive-brown powder, which often is inclosed for a time in a delicate, silvery membrane. This membrane usually is ruptured by the time healthy heads are in bloom, and by harvest a naked spike is all that remains of the diseased head, fig. 35.

**Life History.**—In general, the life history of barley loose smut is similar to that of wheat loose smut, given on page 38. The smut powder, each grain of which is a spore of the smut fungus, is distributed by air currents to the flowers of healthy heads. As a rule, these spores alight within the flowers, germinate

and infect the developing grain. When sown, this grain produces a diseased plant. But in some varieties, especially winter barleys, the spores only lodge between the kernel and the hull, remaining dormant there until the seed is sown. Then, as the seed sprouts,



Fig. 35.—Loose smut of barley. Spikelets of the heads on infected plants are transformed to masses of olive-black powder, which shatters off, leaving only the bare head-stem. The head at the left is normal.

the spores germinate and infect the young shoot before it grows above the ground. After the fungus gets within the shoot, development follows the course described for wheat loose smut.

**Importance.**—Taken year after year, loose smut is the most destructive disease present in Illinois barley fields. Infected heads, because they are completely destroyed by the disease, are a total loss. The infection in individual fields may be as high as 15 or 20 per cent, and for the state as a whole the average runs from less than 1 per cent in certain years to as high as 10 per cent in others. Field counts of smut made in representative fields in 13 years between 1924 and 1938 show an average annual prevalence of 2.8 per cent.

**Control.**—For the control of barley loose smut carried as infection within the seed, the hot water treatment described on page 127 should be used. The temperature of the third bath can be kept at 125 degrees or 126 degrees F. A 15-minute immersion at the first or a 13-minute immersion at the second temperature is necessary. The temperature of the water must not fall below 125 degrees F. or the treatment will not be effective, and it must not rise above 129 degrees F. or the seed will be injured.

To control the second type of infection, in which ungerminated spores are carried by the seed, soaking in formaldehyde or in an organic mercury compound solution is satisfactory. Thorough dusting with a good organic mercury dust also has been found to control loose smut fairly well. In cases of severe infection, however, it is desirable to use the hot water treatment and follow it with the organic mercury treatment.

Among barley varieties, Velvet, Glabron and Wisconsin No. 38 are susceptible to loose smut. Peatland, Improved Manchuria and Trebi are resistant.

## COVERED SMUT

*Ustilago Hordei*

Covered smut of barley is limited to barley and does not infect any other cereal. Because in the field it often can be distinguished from loose smut only with difficulty, its importance has not been fully appreciated.

**Appearance.**—As the name suggests, the smut masses that characterize this disease are inclosed when they emerge and remain covered for a long time, often until harvest. Diseased plants are late in heading out, as a rule one to two weeks later than healthy plants or plants infected with loose smut, and the heads emerge very irregularly, more often by bursting through the side of the boot than by pushing through the end. The chaff, the kernels and often the bases of beards are replaced by black smut masses, which are held in place by persistent, tough, grayish-white membranes, fig. 36. There is no olive tint present in the smut mass, as in the case of loose smut, but instead the covered smut mass is purplish or coal black. The covered smut masses are not released from their inclosing membranes until threshing, unless the membrane is broken accidentally before that time. But, as this membrane is often prematurely ruptured, covered smut is difficult to distinguish from loose smut.



**Life History.**—The masses of smut broken open in threshing disintegrate into innumerable fine particles, each particle being a spore of the covered smut fungus. Many of these spores lodge on



Fig. 36.—Covered smut of barley. Although the spikelets of infected heads are transformed to masses of black powder, they remain more or less intact until harvest. The head at the left is normal; the others are smutted.

healthy grain, especially in the groove, where they remain dormant until the seed is sown. When the barley seed begins to germinate the spores also germinate and infect the young shoot as it emerges from the seed coat, or shortly afterwards. After the fungus has entered the seedling, it continues to grow with the shoot and eventually replaces the grain and chaff with spore masses. These spores are then ready to infect the seed of another crop.

**Importance.**—Covered smut occurs in barley fields throughout Illinois and is responsible to a considerable degree for the reductions in barley yield attributed to smut infections. Because it generally is not distinguished from loose smut in field surveys, its real importance is not known.

**Control.**—Since the covered smut spores are carried on the barley seed, treatment of the seed with a good contact fungicide will control the disease. Organic mercury dust and formaldehyde, as described on pages 128 and 123, are effective. Sowing seed in a cool, moderately dry soil will aid in checking the disease, since warm, moist soils are known to favor infection. The varieties Glabron and Peatland are somewhat resistant; Trebi, Improved Manchuria and Velvet are susceptible.

## POWDERY MILDEW

*Erysiphe graminis*

Powdery mildew of barley is similar in every respect to powdery mildew of wheat, which is described fully on page 50.

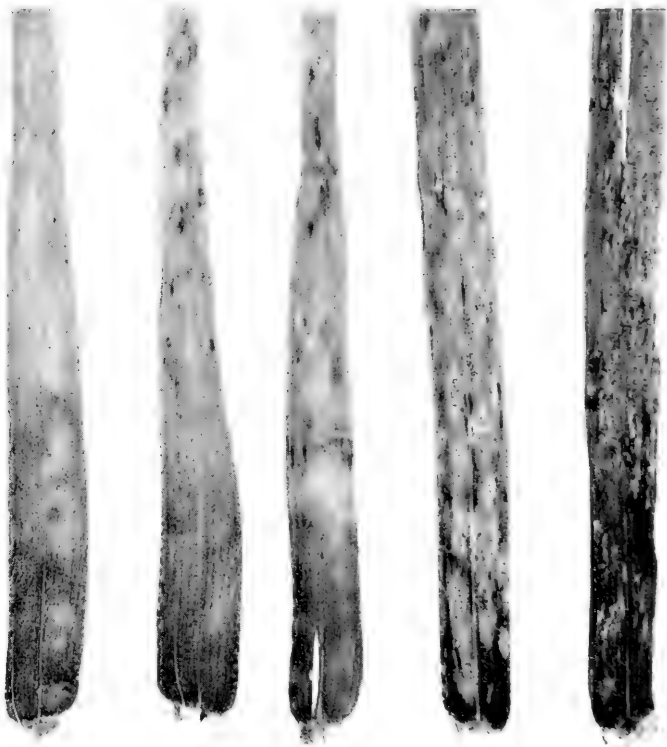

Fig. 37.—Powdery mildew on barley. Light colored areas on the three leaves at the left are young colonies of the powdery mildew fungus. The two leaves at the right show older mildew spots, upon which the minute, black spore-bearing bodies are visible.

It does not damage the barley crop in Illinois sufficiently to be counted among the serious diseases. (See fig. 37.)

## ERGOT

*Claviceps purpurea*

Ergot on barley is the same disease as ergot on rye or wheat, described on page 106. The earliest visible sign of ergot infection in barley is a yellowish, sticky honeydew that oozes from infected flowers. Near maturity the grain is replaced by the characteristic black, hornlike body known as an ergot. Ergot grains in barley heads do not become as large as in rye heads.

Because of the slight susceptibility of barley, the disease is of no economic importance. A few records of its occurrence in Illinois are available, but it never has been found in abundance in any barley field.

## Rye Diseases

Although the acreage devoted to rye in the state of Illinois, ranging in different years from 45,000 to 1,275,000 acres, is less than that given over to any of the other small grains, rye diseases are sufficiently destructive to merit more serious consideration than they have received. Few data are at hand to demonstrate actual rye losses from disease attack, but the number and kinds of diseases to which the crop is subject make it certain that such losses are by no means insignificant.

Closely related botanically to wheat, rye is subject to attack by a number of diseases best known for their destructiveness to wheat, is subject also to the diseases common to all the other small grains and has a short category of diseases distinctly its own. The loose and stinking smuts of wheat attack rye; scab, stem rust, anthracnose and the *Helminthosporium* disease attack rye as well as all other cereals. And rye has a leaf rust, a *Septoria* leaf spot, a scald spot and a smut of its own. There seldom is a year when these diseases do not reduce the crop by at least 5 per cent.

Control measures for rye diseases are essentially the same as those for wheat and barley diseases, except that rye diseases cannot be combated as yet by the growing of resistant varieties, as too little is known regarding the reactions to disease of rye types and varieties.

### DIAGNOSTIC KEY FOR RYE DISEASES

- |   |   |
|---|---|
| 1. Roots diseased.....  | 2                                       |
| Aboveground parts of the plant obviously diseased.....                        | 3                                       |
| 2. Rotted roots reddish brown, often covered with a gray or pink mold.....    | Scab, p. 102                            |
| Rotted roots with small brown spots, or the whole root brown and brittle..... | <i>Helminthosporium</i> disease, p. 103 |
| 3. Plants diseased in the seedling stage.....                                 | 4                                       |
| Plants growing beyond the seedling stage before appearing diseased.....       | 5                                       |
| 4. Seedlings rotted off at the ground line.....                               | <i>Helminthosporium</i> disease, p. 103 |
| Seedlings stunted and yellowed, roots reddish brown.....                      | Scab, p. 102                            |
| 5. Entire plant diseased.....   | 6                                       |
| Special parts of the plant attacked.....                                      | 9                                       |

6. Plants crinkled and malformed,  
often dwarfed. . . . . Nematode disease, p. 109  
Plants normal in form, always stunted or dwarfed. . . . . 7
7. Leaves mottled with alternating narrow streaks of  
dark and light green. . . . . Mosaic, p. 108  
Leaves not mottled, plants whitish or red brown. . . . . 8
8. Plants stunted, whitish, prematurely ripened. . . . . Anthracnose, p. 103  
Plants dwarfed and reddish brown,  
usually occurring together in circu-  
lar areas. . . . . Helminthosporium disease, p. 103
9. Heads diseased, leaves and stems normal. . . . . 10  
Leaves or stems diseased. . . . . 13
10. Chaff or grain, or both, transformed to black  
powder. . . . . Loose smut, p. 105  
No transformation of head to black powder. . . . . 11
11. Entire heads blighted, bleached and prematurely  
ripened. . . . . Anthracnose, p. 103  
One or more spikelets per head diseased. . . . . 12
12. Chaff blighted, often pink with mold. . . . . Scab, p. 102  
Grain transformed into large, hard, purplish gall. . . . . Ergot, p. 106
13. Disease apparent chiefly on stems. . . . . 14  
Disease apparent chiefly on leaves. . . . . 17
14. Stems showing very long, lead-colored to black  
stripes. . . . . Stem smut, p. 103  
Stem lesions showing as pustules or spots. . . . . 15
15. Small red to black, ragged-edged pustules  
present. . . . . Black stem rust, p. 99  
Spots or blotches present. . . . . 16
16. Stem base with numerous rust-brown  
spots. . . . . Helminthosporium disease, p. 103  
Stem with purplish, water-soaked blotches near  
the joints. . . . . Anthracnose, p. 103
17. Leaves with long, lead-colored to black stripes. . . . . Stem smut, p. 103  
Leaves with small pustules or large spots. . . . . 18
18. Disease showing as small brown or black  
pustules. . . . . Leaf rust, p. 98  
Disease showing as spots, various in size and shape. . . . . 19
19. Spots covered externally with gray, floury  
growth. . . . . Powdery mildew, p. 107  
Spots consisting simply of discolored leaf tissue. . . . . 20
20. Spots in the form of yellowish to brown, translucent  
streaks. . . . . Bacterial blight, p. 101  
Spots broad, oval or elongated. . . . . 21
21. Spots light brown, very light in the center, darker  
at the edge and surrounded by a yellowish halo. . . . . Scald, p. 100  
Spots brown to dark brown, uniformly  
colored, without halo. . . . . Helminthosporium disease, p. 103

## LEAF RUST

*Puccinia rubigo-vera*, var. *Secalis*

The leaf rust of rye, known also as brown rust, attacks none of the other cereals and has no other hosts among American grasses. It is comparable, among rye diseases, to the leaf rust of wheat, crown rust of oats and leaf rust of barley. Although it has,

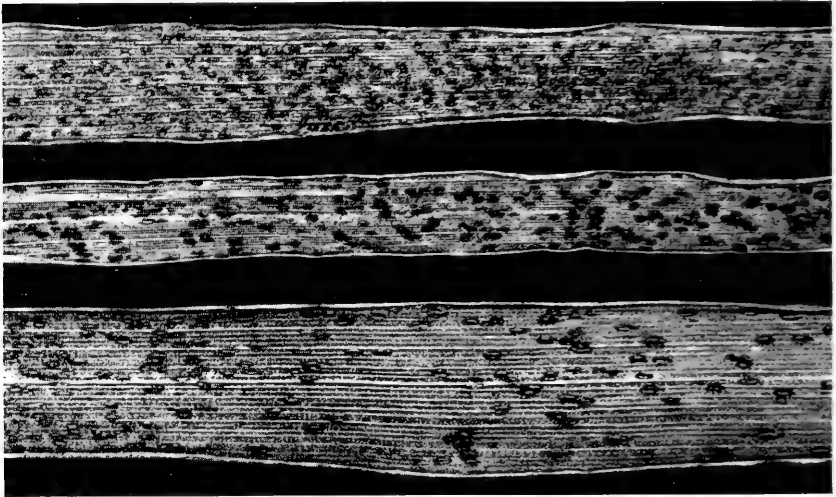

Fig. 38.—Leaf rust of rye. The pustules shown are the brown, summer-spore pustules, from which are shed the spores that serve to spread the rust during the growing season.

like the other cereal rusts, a complicated life history which involves another host, the full life history seldom is completed.

**Appearance.**—Leaf rust of rye is similar in appearance to leaf rusts of other cereals, with exception of color. On either surface of the rye leaf, small, oval, brown pustules are formed. These pustules break open as the rust develops, and powdery masses of reddish-brown summer spores are exposed, fig. 38. Elongated pustules may develop on the stem also, and these resemble short pustules of stem rust. Toward maturity of the plant, small, elongated, dark gray pustules appear, which do not immediately break through the epidermis. These pustules contain the winter spores.

**Life History.**—Rye leaf rust is unique among cereal rusts because its winter spores germinate when they are formed in the fall and because it overwinters by means of its summer spores.

Original infection of rye plants in the spring results in the production of open, brown pustules on the leaves, within which large numbers of summer spores are formed. Distribution of these summer spores results in further rye infection, from which new pustules arise after a period of 7 to 10 days. Continued repetition of this summer cycle under favorable weather conditions may result in destructive rust epidemics. As rye plants mature, brown pustules are no longer produced, but in their place dark gray, covered pustules appear, within which winter spores are formed. Unlike the winter spores of most cereal rusts, the majority of spores of this rust germinate upon maturing and bear, without first infecting any host, other very perishable spores which are capable of infecting certain annual herbs commonly called bugloss. Upon the leaves of these herbs, cluster cup structures bear still another kind of spore, which reinfects rye plants and, in so doing, starts another annual rust cycle.

In America, bugloss is relatively rare, and infection of its leaves by the rye leaf rust fungus seldom occurs. Hence it is not a factor in perpetuating the rust. Instead, overwintering of summer spores occurs, and the annual cycle does not differ from the summer cycle, except for the intervention of winter dormancy.

**Importance.**—Leaf rust is the most seriously destructive of the diseases attacking rye in Illinois. Epidemic in nature, it varies from year to year both in prevalence and in the intensity of its attack. Data taken in field examinations during 15 seasons show that as an annual average almost exactly 80 per cent of the rye plants of the state become diseased and that the disease reduces leaf area by 12 per cent. Actually, in different years, the prevalence of the disease has ranged from 19 to 100 per cent, and the destruction of leaf area has ranged from 0.9 to 46.4 per cent.

**Control.**—Because of the small importance of rye as a crop, control of its leaf rust has received little attention. Rye varieties exhibit only slight differences in susceptibility to attack, but a strain of Abruzzes rye has been found to be resistant.

## BLACK STEM RUST

*Puccinia graminis*

Black stem rust of rye is caused by a special race of the stem rust fungus so limited in its host range as to be able to attack, besides rye, only barley and two wild grasses, meadow fescue and

quack grass. In appearance and life history it does not differ from the black stem rust of wheat described on page 20.

Rye matures so early in Illinois that it seldom is damaged by black stem rust. During 15 years of field survey only three crops have been observed to be seriously affected. In 1922 stem rust attained a prevalence of 50 per cent and accomplished destruction of 25.6 per cent of stem area; in 1924 the prevalence was 25.9 per cent and the stem area destroyed was 13.9 per cent; and in 1934 the prevalence was 3 per cent, accompanied by an insignificant destruction of stem area.

Control appears to be necessary only at long intervals. No adequate measures are at hand. In northern Illinois, eradication of the common barberry may eliminate the possibility of destructive local attacks.

## SCALD

### *Rhynchosporium Secalis*

Scald occurs on rye in the form of a leaf spot. In some states it attacks barley also, but there is no record of it on barley in Illinois. The most important wild hosts are wild barley, orchard grass, quack grass, wild rye and brome grass.

**Appearance.**—Scald spots are yellow at first, with a bleached appearance. They are broadly oval or lens-shaped, with their long axis paralleling the long axis of the leaf, fig. 39. As a spot ages its center becomes white or very light brown. Around this center is a darker brown border inclosed in a yellowish band or halo, which gradually fades into the green of the leaf. Oftentimes spots become somewhat elongated, when much of the tissue above and below them loses its green color. If a spot is very broad, all of the leaf beyond the spot dies.

**Life History.**—Very little is known about the life history of the fungus that causes rye scald, but it is reported to be seed borne. There is also a possibility that its spores live over winter on wild host plants.

**Importance.**—Scald is so rare in Illinois that it causes very little reduction in the rye yield. It damages the rye plant chiefly by destroying leaf tissue, which reduces the plant's food-building ability. Hence, if infection is severe, shriveled kernels are the result.

**Control.**—The present importance of the disease does not warrant control measures; but general methods of control used





Fig. 39.—The scald disease of rye. Infection of leaves by a parasitic fungus results in the appearance of oval, bleached spots, which greatly reduce the food-making capacity of affected leaves.

for other diseases ought to aid in controlling it, if it should become a serious factor in rye production.

### BACTERIAL BLIGHT

*Bacterium translucens secalis*

Although the bacterial blight of rye is the same disease as the bacterial blight of barley, only a special variety of the bacterium that causes the disease can attack rye. Hence diseased rye does not endanger barley, and diseased barley does not en-

danger rye. Bacterial blight was first observed on rye near Bloomington, Ill., in 1921. It is, however, of no economic importance. A full discussion of appearance, life history and control of bacterial blight is given under barley diseases (page 82).

## SCAB

*Gibberella Saubinetii*

Rye scab, called also *Fusarium* blight and head blight, is the same disease as scab on other cereals. A full discussion is given under wheat (page 28). Badly diseased kernels are wrinkled



Fig. 40.—Scab on rye. Infected spikelets are light colored and blighted, and produce shriveled grain. Rye heads seldom become diseased throughout.

and shriveled, having a rough surface, and are covered with a powdery, carmine growth. Lightly affected kernels are dark brown. Rye scab is of little economic importance in Illinois, although the disease can be found every year. (See fig. 40.)

Control consists in the use of sanitary farm practices, clean seed and seed treatment, as directed on page 31.

## ANTHRACNOSE

*Colletotrichum cereale*

Anthracnose on rye is very similar to wheat anthracnose, described on page 31. Resulting stem discoloration is, however, more pronounced on rye than on wheat. Affected rye plants are often stunted and blighted, and the portion of the head above a localized point of attack is killed, resulting in worthless or badly shriveled grains in that part of the head. This disease on rye has been reported from 22 counties, representing all parts of Illinois, but the loss attributable to it is slight. Control measures include sanitation, crop rotation, use of clean seed and seed treatment.

## HELMINTHOSPORIUM DISEASE

*Helminthosporium sativum*

This is the same disease as that which occurs on wheat and is identical also with spot blotch of barley. The symptoms given for the disease on wheat, page 33, may be expected to appear on rye. The general discussion given under wheat applies also to rye. There are only a few records of the occurrence in Illinois of Helminthosporium disease on rye, and the loss caused by it is very small.

## STEM SMUT

*Urocystis occulta*

Stem smut of rye is closely similar to flag smut of wheat and is caused by a very similar fungus. The rye smut, however, cannot attack wheat, nor can the wheat smut attack rye.

**Appearance.**—First signs of stem smut infection on rye appear when the stems approach a foot in height. Diseased plants have a darker green color than healthy ones, and traces of lighter green streaks may be observed in the upper leaves. Soon these plants develop the characteristic symptoms of the disease: long, lead-colored stripes on leaf and stem, which soon become black and break through the leaf tissue, exposing dusty masses of spores, fig. 41. Affected parts are often badly twisted and distorted, and the leaves split along the stripes. Stems and leaves are attacked most frequently, but smut pustules may be found on the chaff when heads are produced. Diseased plants usually are stunted; they rarely head out.

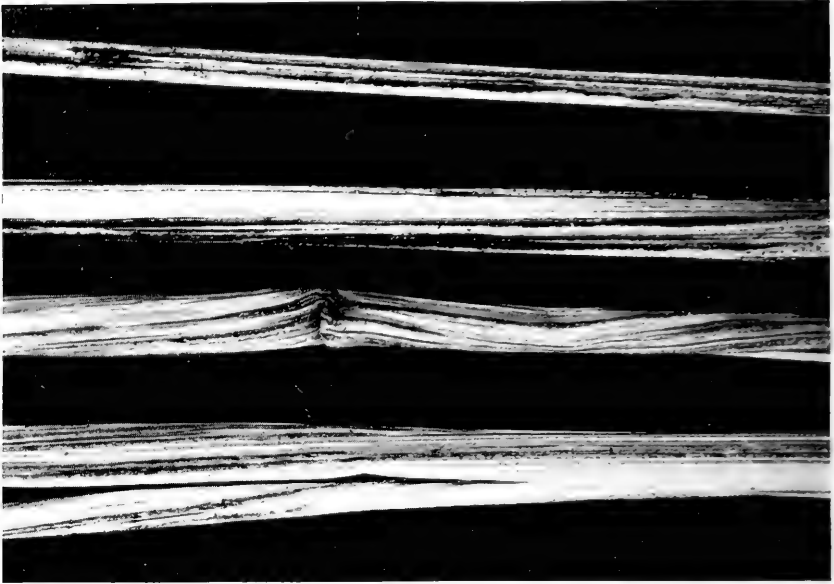

Fig. 41.—Stem smut of rye. Infection of the rye plant results in the production of lead-colored stripes running lengthwise of the leaves and stems. The stripes break open eventually, setting free the masses of black, powdery smut spores with which they are filled.

**Life History.**—The disease carries over from year to year in the form of spores which adhere to the seed or infest the soil. Germination of these spores and infection of rye seedlings is similar to that described for flag smut of wheat on page 42. Subsequent growth of the fungus takes place in the growing plant, and the new crop of spores is not formed until just previous to the heading of the plant.

**Importance.**—Stem smut has been of very little consequence in Illinois, but of the three smuts attacking rye it is the most important. Prior to 1935 there were only a few records of its occurrence, but in 1935 it was found in five counties in the southern half of the state and in one county in the northern half. Infection ranged from a trace to 8.6 per cent of the plants examined. This is the highest percentage of diseased plants on record for the state. Should the disease continue to increase in severity, growers should begin treating seed.

**Control.**—Because they are borne externally on rye seed, stem smut spores can be killed by seed treatment with copper carbonate dust. Other treatments of a similar kind are described

on pages 126 and 128. Seed treatment, except with organic mercury dust, does not prevent infection from spores in infested soil.

## LOOSE SMUT

*Ustilago Tritici*

Loose smut, or head smut, of rye is caused by the same fungus that causes loose smut of wheat. Rye, however, is only slightly susceptible. While the general appearance of the disease is the same on both crops, the entire rye head is seldom replaced by the fungus, as is the wheat head. The disease is so rare that control measures are not required; however, those recommended on page 40 for loose smut of wheat are applicable. (See fig. 42.)



Fig. 42.—Loose smut on rye. As a rule only a part of the spikelets on a diseased head are transformed into black spore masses, but these shatter off, leaving the stem bare, in the same manner as in loose smuts of other crops.

## ERGOT

*Claviceps purpurea*

Ergot attacks the kernels but no other part of the rye plant. Wheat and barley, though sometimes attacked, are much less susceptible than rye. Grasses such as meadow fescue, quack grass, orchard grass, timothy, redtop, bluegrass, squirrel tail, wild rye, brome grass and meadow foxtail are also hosts of ergot, and from some of these infection may spread to rye. Ergot grains contain a very poisonous substance known as ergotine, and ergot poisoning may prove fatal to stock fed on heavily infected grain. Usually, the disease is not prevalent enough in Illinois to endanger live stock.

**Appearance.**—The first sign of ergot infection becomes evident soon after flowering of the grain, when yellowish drops of a sticky fluid called honeydew ooze from infected flowers. This

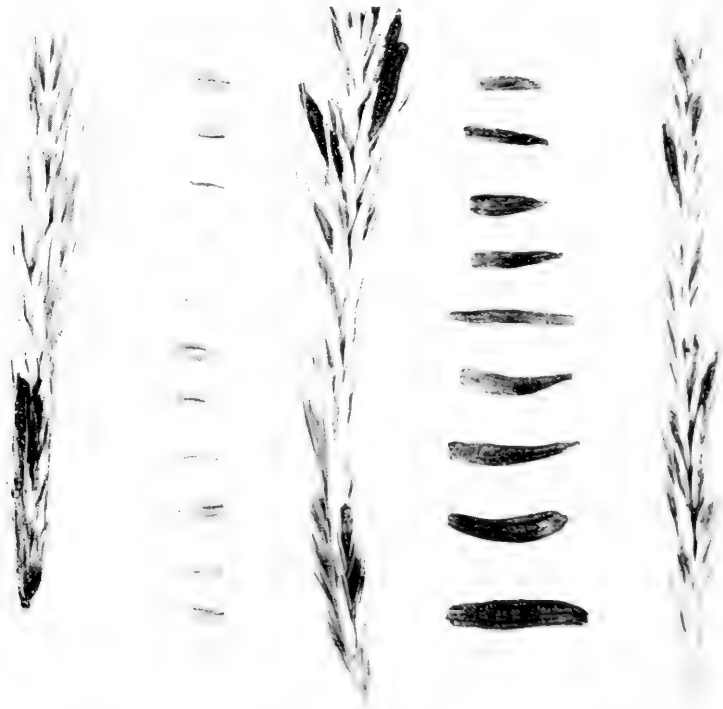

Fig. 43.—Ergot on rye. Kernels infected by the ergot fungus are changed into long, hard, dark violet bodies several times the size of a rye kernel.

honeydew may cover the greater part of the head, which later becomes dark from adhering dust. The most characteristic and easily recognized symptom is not noticed, however, until the grain begins to ripen, when the kernel is replaced by a hard, violet, hornlike body several times the size of a normal grain. These bodies, known as ergots, are elongated and somewhat curved; they resemble the rye grain in general outline, fig. 43.

**Life History.**—The ergots may drop to the ground during handling of the cut grain and remain dormant during the winter, or they may be sown with the seed. In the spring, if they are near the surface of the soil, they send up several small, mushroom-like growths with small, thin stalks and globular heads. In these heads, spores are produced, which are shot forcibly into the air and carried by air currents to blossoming rye heads. These spores, germinating on the flower, infect the kernel and replace it with a mold growth which secretes a spore-laden, sticky honeydew, that insects and rain distribute to other plants. New infections are produced as long as host plants are in blossom and susceptible. The infected grains are transformed into ergots before maturity of the host.

**Importance.**—In general, ergot causes only a negligible reduction of rye yield in Illinois. Although severe infections have been reported occasionally, it generally is very difficult to find ergot-infected heads in rye fields. The disease occurs throughout the state but usually it is abundant only on rye growing in wheat. The importance of ergot, as a rye disease, is therefore due not to its destructiveness in the rye crop but rather to the fact that it can occasionally contaminate wheat to such an extent that the use of wheat straw, the grain itself, or flour made from it, as food may give rise to ergot poisoning, the worst results of which are gangrene and abortion.

**Control.**—Rotation of crops, removal of all ergots by fanning or a brine bath, and sanitation are the chief control measures. It is important to keep down the growth of susceptible grasses.

## POWDERY MILDEW

*Erysiphe graminis*

While powdery mildew on rye does not differ from the same disease on wheat, oats and barley, the fungus that causes it has developed into a highly specialized race unable to attack the other cereals. Rye is probably more resistant to the disease than

wheat. On rye it is of no economic importance in Illinois and is rarely found. The discussion given under wheat diseases on page 50 indicates the life history and control.

## MOSAIC

### *Triticum Virus 1*

Mosaic of rye, a virus disease, is the same as the mosaic of wheat, discussed on page 52. The symptoms are the same on both crops. (See fig. 44.) None of the rye varieties are known



Fig. 44.—Rye mosaic. Plants infected with the mosaic virus have leaves mottled with yellow green and dark green. Such mottling is a characteristic symptom of the disease. The mottle pattern varies greatly, being sometimes predominantly yellow, sometimes predominantly green.

to be resistant to mosaic. The mosaic virus can persist in soil for as long as six years. Consequently, fields heavily infested with mosaic should not be planted to either rye or wheat for at least that length of time.



**NEMATODE DISEASE***Tylenchus tritici*

As is the case in wheat, the nematode disease in rye is caused by a small, eellike worm. Rye is attacked almost as readily as wheat, emmer and spelt, but oats, barley and certain grasses are seldom, if ever, attacked. The characteristics of the disease are as given on page 56, under wheat, except that the galls are straw-colored in rye instead of dark brown or black. There are no records of the occurrence of nematode infection of rye in Illinois.

## VI

### *Cereal Disease Control*

Most of the earliest methods suggested for the control of plant diseases were based on superstition. Many of them, if suggested today, would be considered ridiculous. But reason and observation entered into some of them. The brine method of seed treatment, for example, was the result of the observations of keen farmers, who noticed that seed which had been taken from a ship sunk in a harbor had less smut than seed which had not received this treatment. The sea water probably had little if any disinfecting value, but it floated off many of the smut balls, reducing the amount of infective material and resulting in less smut in the crop.

It is only within comparatively recent times that the parasitic habit of bacteria and fungi has been recognized as a cause of plant diseases. Most information of this nature has been worked out in the last 50 years. An understanding of the life history of the parasite concerned, its method of injury, its means of dissemination, and of conditions favorable for its development and spread, is essential to the choosing of proper control measures. Recommendations for control or prevention of diseases now are based upon a knowledge of causal organisms, and fungicides or other treatments recommended are the result of years of experimenting, testing and improving by many workers.

With cereals, as with most other plants, protecting from infection is more practical than attempting to cure. The value of the individual plant is so small that, even if cure were possible, the cost would be prohibitive. Most preventive measures now in use, even seed treatments, are inexpensive. The old adage, "An ounce of prevention is worth a pound of cure." is applicable to the control of cereal diseases, but the ratio might well be increased to many times a pound of cure. Many diseases now can be controlled satisfactorily by the use of specific measures and others can be partially controlled, but there are certain diseases which cannot be controlled practically by any means known today.

Present means for controlling cereal crop diseases arise from good farm practices, they are concerned with legal regulations and inspection, and they involve seed treatment. They are discussed in the following pages.

## GOOD FARM PRACTICES

Because of differences in the life histories and habits of disease-producing organisms, no set of measures will apply to all diseases. What measures a grower uses should be determined from a study of the number and severity of diseases in his locality, their habits of spread and infection, local soil and climatic conditions, and particularly the diseases prevalent on the crops grown on his own farm.

In plans for a disease control program, the source of infection must be considered. Seed-borne diseases can be controlled, as a general rule, by one or more of the seed treatments, and diseases caused by soil-inhabiting fungi often can be controlled to a limited extent by certain chemicals which will adhere to the seed when it is planted. Diseases caused by wind-borne spores, however, are not affected by seed treatment, and other methods must be employed which would not be profitable for disease control alone but which pay big dividends in connection with other farm practices.

**Sanitation.**—One of the important preventives of plant disease is sanitation. By sanitation is meant the elimination or destruction of disease-carrying materials. Bacteria and spores of fungi, the chief means of infection for many diseases of above-ground plant parts, are carried to plants by air currents. Often, the source of this inoculum is crop refuse, weeds, volunteer plants or alternate hosts. Practicing sanitary measures reduces the amount of inoculum present for air currents to carry, but the inoculum must be eliminated before the new crop is present if sanitation is to be effective.

One of the most effective sanitary measures is that of burning. This, however, results in destruction of organic matter, which is badly needed in many Illinois soils, and burning crop refuse is not generally recommended unless the grower can make provision to replace the organic matter destroyed. Thorough plowing, so as to cover all straw, stubble and other diseased material, prevents spores from getting into the air. But, in some cases, plowing under diseased material and later planting a susceptible crop on the land results in infection of young seedlings or roots that come in contact with infested material. However, the benefit derived from plowing under crop refuse usually more than offsets any loss occurring from underground infection. In addition to the crop refuse, weed hosts and volunteer plants

should be destroyed. Infested straw, cornstalks and manure should not be used as top dressing.

The value of sanitation in controlling barley scab has been demonstrated to the writer numbers of times. In the bad scab year, 1928, the difference between plowing and disking ground before sowing was quite evident in the amount of scab present in the crop. The farmer who plowed the ground before sowing, turning under old cornstalks and rotten ears in which scab fungous spores were produced, had very little scab in his barley crop. But neighbors who merely disked the ground before sowing, cutting up the stalks but leaving most of them uncovered on the surface, had so much scab that their barley was almost worthless as feed and could hardly be sold.

The value of sanitary measures depends upon thoroughness and the size of the project. The larger the area over which sanitation is practiced, the greater will be the benefit derived.

**Rotation of Crops.**—The value of crop rotation in maintaining the fertility and productivity of the soil is generally appreciated. In addition to its other benefits, rotation does much to control weeds and to reduce the destructive work of insects and fungous diseases. Continuous cropping of land to a particular crop results in building up in the soil a population of fungi parasitic on that crop. Other things being equal, the higher this population becomes the greater the loss to the crop. By rotation the continuity of favorable hosts is broken and the destructiveness of the disease is reduced.

Certain disease-producing organisms can live in the soil for indefinite periods on almost any type of organic matter. They are hard to control, but rotation checks their destructiveness. Other soil fungi, not so omnivorous and more closely limited to their host plants, diminish in abundance as host material disappears. A rotation system long enough to allow the refuse of a crop to decay before the same crop is replanted reduces to a minimum the ravages of these fungi.

**Resistant Varieties.**—Losses from certain diseases may be greatly reduced, or in some cases completely eliminated, by the use of geographically adapted resistant or immune crop varieties. The production of new crop varieties resistant to disease is largely a task for the plant breeder, but many resistant selections have been made by observant farmers through choosing outstanding individuals among large populations of diseased plants. When plants are found that seem to be immune or resistant to disease.

the seed from them should be saved and planted separately. Should the absence of disease be due to inherent resistance, this characteristic will persist. It is this inheritance of characters that makes it possible for the plant breeder to produce new varieties which are resistant to disease.

Varieties resistant to the various diseases have been listed under each important disease. Unfortunately, a variety may be highly resistant to one disease but very susceptible to another. In choosing a variety, it is necessary to check both its reaction to other serious diseases and its adaptability to the grower's locality.

**Cultural Methods.**—The term cultural methods is used to include certain adjustments of farm practice that will aid crops in resisting disease attack or will tend to produce profitable returns in the presence of disease. That plants do not grow well if one or more factors of the habitat are unfavorable is well known to every grower. Likewise, the growth of parasitic bacteria and fungi is affected by environmental factors.

The two great constituents of the environment of cereal crops are soil and weather. Temperature and moisture, both in the soil and in the air, influence both host and parasite. Environment can be modified by indirect methods, as through cultural practices. This modification may influence the host more than the parasite but, regardless of which is affected, even slight modification may greatly reduce losses due to disease.

Soil, the medium in which the plant grows, furnishes the water and minerals necessary for plant growth. Fertility, composition, acid reaction, drainage, temperature, moisture content and other characteristics of the soil affect plant growth and, directly or indirectly, also influence disease attack. In general, the more favorable conditions are for plant development the greater the produce will be, even though some diseases may be intensified. Most treatments that can be given the soil to balance the supply of minerals, correct acidity or furnish proper drainage and aeration will be beneficial to the plant. However, the application of manure containing infested straw just previous to seeding may increase the amount of infective material. Hence, the application of a top dressing heavily infested with some serious crop disease is not advisable.

Preparation of the seed bed also has a marked influence on plant growth and, indirectly, on the amount of disease. With certain diseases such as loose smut of oats and stinking smut of

wheat, in which the fungus must enter the seedling before the latter emerges from the soil, the more favorable the seed bed is to rapid growth the shorter the period of susceptibility will be and the less apt infection is to occur. In such cases environment affects the host, not the parasite. Soil thoroughly turned over so as to bury weed seeds and disease-bearing debris greatly reduces the danger of infection for aerial parts of the crop.

Eradication of weeds not only reduces competition for moisture and food materials but also eliminates a fruitful source of infective material for certain diseases.

The date of seeding also influences certain diseases. Early sowing, when the soil is warm, is favorable to heavy seedling blight of wheat. There is an abundance of pentose sugar in the plant when the weather is warm and this seems to favor the disease. Barley stripe infection is less when seed is sown in warm soil than when sown in cold soil. A late variety of oats sown as early as possible is likely to escape crown rust infection, since the crop will be nearly mature before the rust appears.

While rate of seeding should be determined largely by soil fertility, available moisture and crop variety, dense vegetative growth produces humid conditions favorable to fungous and bacterial infection. Rate of seeding can control this factor of the environment to some extent.

The depth of seeding has a bearing on infection. In the case of certain smuts, the shallower the seed is sown, provided there is sufficient moisture available for germination, the sooner the seedlings pass the stage of susceptibility.

The use of early maturing varieties, in the presence of oats crown rust and certain other diseases, will greatly lessen the amount of damage in ordinary years. The rust usually does not make its appearance until late in the development of the crop, and early varieties will be ripe before heavy infection can occur. The yield of late maturing varieties, on the other hand, may be greatly reduced by disease and hot weather.

Care of the cereal crop at harvest often is important in reducing the loss from disease. This is true especially in infestations of certain head diseases such as scab, which in 1935 continued to develop after the crop was in the shock. The dryness of the grain before shocking and the size of the shock determine the rate of drying and the length of the susceptible period.

**Good Seed.**—Good seed is a most important requirement in crop production. Even if all other factors are at the optimum, a

poor crop will result if poor seed is used. It is essential to select a variety that is adapted to the locality and, after it has been found, its other characteristics must be studied to make sure it will fit the needs of the grower. Among these characteristics are its date of maturity, its ability to withstand extremes of the climate, its ability to yield, its susceptibility to the most important diseases and the quality of its grain.

When such a variety has been chosen, the seed should be well cleaned before being sown. This is best done by fanning and screening, a practice now used by many farmers but one that should be universal. The ordinary fanning mill is adequate for farm use and, with properly sized screens and proper amounts of air, satisfactory results can be obtained. Weed seeds, foreign materials, smut balls and many inferior grains are removed. Among these inferior grains will be those that are light in weight and shriveled as a result of disease attack. Many of these would not germinate or, if they did, would produce poor stands, weak plants and small yields. Only large, heavy, plump, clean grains should be sown.

The value of fanning wheat seed as a means of reducing stinking smut infection was illustrated accidentally by a Clay County farmer who cleaned by fanning the seed he thought he would need for sowing in the fall of 1934. When he sowed his field, the clean seed was sufficient to plant all but a strip 5 rods wide. This he sowed with similar, but uncleaned, seed from his bin. Neither lot of seed was treated. By actual count, 4.1 per cent of the heads from the seed that was not fanned were smutty, while only 0.8 per cent of the heads from the fanned seed was smutty. Yet this farmer had been unaware of the presence of the disease in his 1934 crop.

The use of disease-free or nearly disease-free seed is another means of controlling disease. This type of seed may be produced in special seed plots, or may be purchased as certified seed. The seed plot is used to the best advantage against diseases carried within the seed, diseases which cannot be controlled by ordinary seed treatments. Loose smut of wheat comes in this category when inadequate equipment makes the seed plot more satisfactory than hot water treatment.

The site for the seed plot must not have had the crop in question, or another susceptible crop, growing on it for a period of two years. The farther the plot is situated from fields planted to the same crop the less danger there is of wind-borne infection.

It is an advantage to have a tall crop or a windbreak on the windward side of the plot if other grain fields are near. The plot should be given especial attention during the entire year, thoroughly cultivated and weeded so as to provide an excellent seed bed and to remove weeds and other sources of infection.

The best seed obtainable should be used. If necessary, it should be given the hot water treatment. Several times during the heading period the plot should be rogued and all smut-infected plants removed before the infection spreads. Plants not true to variety can be removed at the same time. Special care is required in harvesting and storing the grain to prevent contamination.

Seed from plots free of smut may be used safely without treatment. Succeeding field crops will remain free of smut until infection is brought in from outside sources. The grower is fairly safe in using seed from subsequent field crops for a year or two. A good supply of clean seed can always be maintained if that from the seed plot is used to sow the next year's plot; but roguing must be practiced each year.

Certified seed bought from reliable dealers will aid in controlling diseases. Such seed carries a minimum amount of infection, since the fields in which it is grown are examined by competent inspectors, who issue certificates only when fields meet rigid specifications with respect to freedom from disease.

**Fungicides on the Growing Plant.**—Although fungicidal sprays or dusts are used extensively by horticulturists to control diseases, they have not been adopted by grain growers. Experiments have shown that fungicides applied to small grains at the proper time result in marked increase in yield, but practical methods of application suitable to Illinois conditions have not been developed. The common use of airplanes for applying fungicidal dusts to the small grains, to reduce the toll taken by disease caused by air-borne spores, is a probability. When the cost of applying sulfur dust by airplanes becomes such that the resulting increase in yield will give a profit to the grower, more attention will be devoted to this method.

## REGULATION

In addition to the above recommendations, the grower may take advantage of other measures designed to prevent serious losses from crop diseases. Among these are inspection, eradica-



tion and quarantine. Not only farmers but state and federal agencies are cooperating in applying these measures to prevent the introduction and spread of serious infections and to control outbreaks.

**Inspection.**—Inspection or examination services may be divided into two classes; namely, inspection of plants and plant materials raised within the United States, and inspection of plants and plant materials imported from foreign countries. These services are very valuable, since certain serious diseases are still not widely spread in the United States, and some diseases known in foreign countries have not entered the United States.

The state and federal governments have trained men who inspect plants for insect and disease infection and thus protect the grower against the introduction of serious pests with purchased material. One of the services of state inspectors is examination of certain grain fields so that seed from them may be sold as certified.

Any grower buying seed of unknown origin should, however, treat it before sowing. Plants or plant parts coming from new regions should be examined upon arrival and several times during the growing season for any abnormalities that may appear. Vigilant inspection of crops may lead to stamping out a new disease before it becomes widely distributed.

**Quarantine.**—The state and federal governments cooperate in establishing quarantined areas for new or destructive diseases whenever segregation is deemed necessary or beneficial. New diseases not at first widespread are distributed, besides other ways, through man's activities. If suitable regulations are made regarding such diseases, or the plants that harbor them, the diseases may be eradicated before they go beyond control. Introduced parasites often attack their host plants more virulently in new territory than in their native lands, and so are generally regarded as more dangerous than native parasites. Quarantined areas are inspected from time to time to determine whether the disease has been eliminated or reduced to such an extent that it is safe to remove the quarantine.

**Eradication.**—Eradication, although generally carried on over large areas by the state and federal governments, can be adopted to good advantage by the individual farmer. Weeds, wild plants and unimportant cultivated plants often serve as hosts to disease-producing organisms of valuable crop plants. In some cases the disease lives on the less valuable plants during the

time of year that the crop plant is not available to it. Eradication of these alternate hosts reduces the amount of infectious material present to attack the crop plant. Eradication of common barberry and buckthorn, alternate hosts of black stem and crown rusts, tends to reduce the amount of these rusts.

The federal government has carried on an extensive program of barberry eradication in Illinois and other states. In many regions, the common barberry has been nearly eliminated, and the danger of severe local stem rust epidemics has been greatly lessened.

## SEED TREATMENT

Seed treatment gives definite insurance against loss from certain seed-borne diseases. Formerly the main object in using seed treatments was to control smut diseases, but with the advancements made in disease research and the accompanying improvement of disinfectants a wider value has been demonstrated. It has been observed that some treatments result in yield increases much greater than would be expected from the control of smut alone. The disinfectants also kill other organisms carried on the seed—organisms which cause rotting of the seed, seedling blights and rotted roots. Increased stands, a greater percentage of healthy plants and larger yields result.

Formalin, copper carbonate, copper sulfate and organic mercury compounds meet the requirements for external seed disinfection. Heat is used, in hot water treatments, to control diseases carried inside the seed. Common seed disinfectants are used in either liquid or dust form. Dust treatments are usually more convenient to use than liquid treatments, give satisfactory control when disease organisms are carried on the seed, protect seed to some extent against attack by soil organisms and contaminated containers, do not cause swelling of seed and do not necessitate a heavier rate of seeding.

**Seed Treatment Suggestions.**—The grower should treat his seed every year. It is poor policy to practice seed treatment every other year or one year in three. While grain may appear to be free of serious disease, there usually is enough infection present to cause appreciable loss. Such infection accumulates while the crop is growing. Also, it may result through contamination from threshing machines.

Experiment stations and manufacturers have made many

tests to find the proper amount of disinfectant to use. Using too little is false economy, since it gives unsatisfactory disease control, while using too much is wasteful and in some cases actually harms the seed, without giving any better control than the recommended amount. Although small errors in the amount of disinfectant used do not matter, it is false reasoning to assume that, if a small amount is good, double the amount is better.

A very necessary practice in seed treatment is thorough application of disinfectants. Failures often result from the use of makeshift treating machines. Dust disinfectants cannot be mixed thoroughly with grain by shoveling grain and disinfectant from pile to pile or by putting the disinfectant on top of the seed in the drill hopper. If organic mercury dusts are used and the seed is stored for several days, gas given off by the dust counteracts to some extent lack of thoroughness in treating. It is much better, however, to cover each grain completely than to depend on the action of the gas.

The length of time seed may be treated before sowing depends upon the nature of the disinfectant. In general, when liquid treatments are used the seed should be sown immediately after it becomes dry enough to pass through the drill. If not sown immediately, it should be dried thoroughly in the presence of plenty of air, to allow injurious gases to escape quickly.

Certain dusts may, without serious seed injury, be applied several days to a couple of months before sowing time, if the seed is kept dry during the storage period. Though tests have shown that injury is done by some organic mercury materials to seed during storage, most if not all of this damage can be eliminated by using a smaller amount of disinfectant.

The fact that a disinfectant gives satisfactory control of one disease does not prove it equally effective for all other diseases. Also, a disinfectant may be injurious to one grain and not to another. Formaldehyde, generally used for oats and sometimes for wheat, will injure both grains if it is carelessly handled, but it is more likely to injure wheat than oats. Copper sulfate and copper carbonate are used principally for wheat; organic mercury compounds may be used on wheat, oats and barley.

Though all dust treatments may harm both the grain and the user if improperly used, they will injure neither if a few precautions are taken. Dust compounds are poisonous and should not be inhaled, and treated seed should not be used as food. If treating is done in the open air and the operator uses a dust mask

or wet cloth over his nose and mouth, little injury will result from the use of these materials. The small amounts of mercury dusts required keep at a minimum the excess dust that flies in the air in the handling of treated seed.

**Machines for Applying Dust Treatments.**—Equipment for applying the dust chemicals may be homemade and inexpensive or may be purchased from manufacturers. Homemade mixers treat from 25 to 30 bushels per hour, while commercial outfits treat up to 500 bushels in the same period. Rotary barrels, figs. 45 and 46, concrete mixers, barrel churns, gravity mixers, fig. 47, and commercial cleaning and treating machines may be used in applying the dust chemicals. The important precautions to remember in using the rotary batch mixers, in which a definite amount of seed and disinfectant are put in the machine for mixing, are that the containers should not be filled over one-third full and that they must be rotated long enough to coat each grain with the chemical—from 30 to 50 complete turns of the machine.

The rotary oil drum mixer, shown in fig. 46, can be constructed by any blacksmith at very reasonable cost and is quite satisfactory for treating all kinds of grain. Probably its greatest disadvantage is the labor required in turning the drum during the mixing operation. A 30-gallon barrel will treat 1 bushel of seed in one operation.

A barrel churn can be used, if only a small quantity of grain is to be treated. The addition of a spreading board will increase its efficiency. Concrete mixers can be used also, if the lid is fastened tightly enough to prevent escape of the disinfectant while the seed is being treated.

A gravity type of mixer devised by the Bayer-Semesan Company may be used for mercury dusts that give off a disinfectant gas, but not for those that do not. Seed and chemical cannot be mixed as thoroughly with this machine as with a rotary treater.

As grain is poured into the hopper of the gravity mixer, the mercury dust is added slowly and continuously by one man at the rate of one-half ounce per bushel of grain. The hopper should never be allowed to become empty during the process. The correct rate of application of the disinfectant may be determined by computing the time required for several bushels of grain to pass through the machine and then calculating the time required for 1 bushel.

Commercial cleaning and treating machines require only one operation to prepare seed for sowing. These machines are

suitable for custom treating. The outfit usually is mounted on a truck or a trailer and is brought to the seed granary. All the farmer has to do is supply seed to the machine and remove the treated seed. The cost for this service generally is low if the convenience, thoroughness and rapidity of the operation is considered. Seed may be cleaned and treated at elevators, seed houses or treating plants, also.

**Copper Sulfate Treatment.**—Copper sulfate, or bluestone,

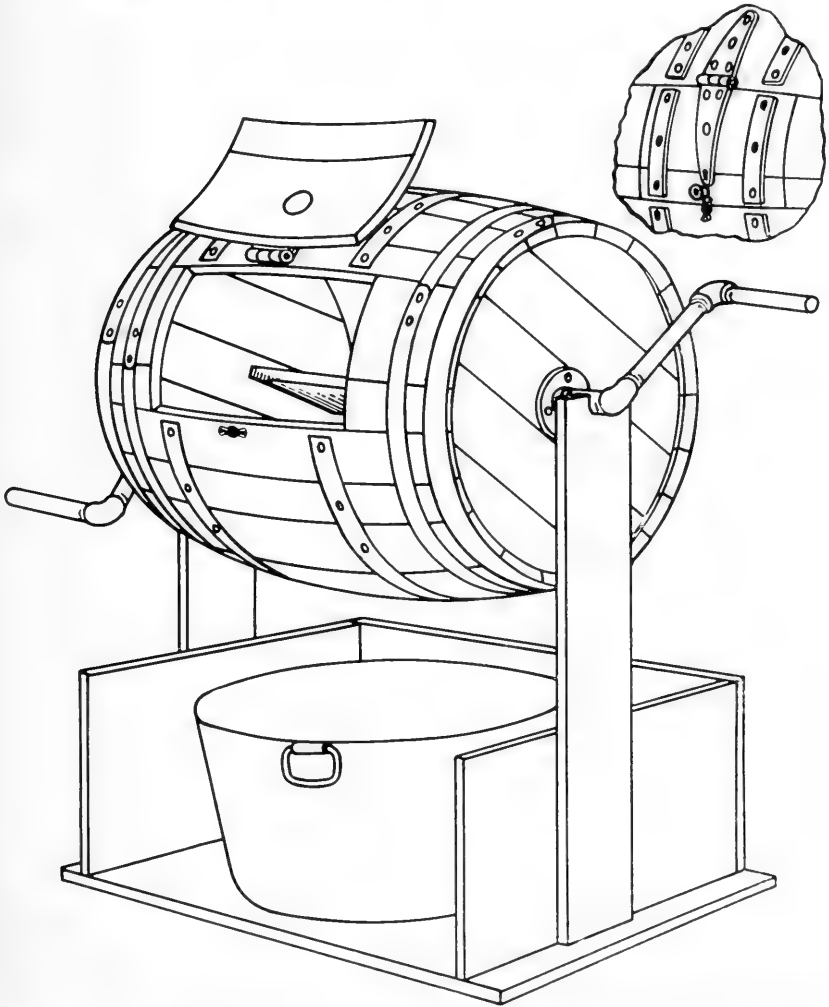

Fig. 45.—Rotary barrel mixer, for treating seed grain with dust disinfectants. (Drawing furnished by the Extension Service, U. S. Department of Agriculture.)

was substituted a number of years ago for formaldehyde as a liquid seed disinfectant because it was less apt to damage the seed. Today, the laborious method copper sulfate necessitates has been replaced almost entirely by other, more convenient treatments.

When it is necessary to use this method, the seed is soaked in water for 10 minutes and kept moist for 5 or 6 hours. A bluestone solution is made by dissolving 1 pound of copper sulfate in 5 to 10 gallons of water. The presoaked seed is dipped in this solution for 5 to 10 minutes and stirred so that all kernels are reached by the solution. Floating grains, smut balls and other debris can be skimmed off the top. To counteract the injurious effect of the bluestone, the seed is then transferred to a lime bath, made by dissolving 1 pound of ordinary slaked lime in 10 gallons of water. After being allowed to remain in the lime bath long enough to become thoroughly coated by the limewater, the seed is drained and spread out thinly to dry.

**Copper Carbonate Treatment.**—Copper carbonate dust has replaced certain other treatments because of its convenience. It offers one of the best means of controlling stinking smut of wheat. Among its disadvantages are the fact that it is poisonous, that it must be mixed very thoroughly with the grain, that it may injure the drill and that it causes a reduction in the rate of seeding. On the other hand, seed may be treated with it at any time without danger of injury if stored in a dry place.

Copper carbonate may injure the drill in three ways. The dust, if it gets damp, cakes in and locks the working parts; it causes excessive wear of gears; and it corrodes exposed metal parts. But such injury may be reduced to a minimum by rocking the wheels of the drill back and forth, or turning the feed gear shaft with a wrench several rounds, each time before using the drill; by using oil freely and frequently to prevent excessive wear; and by thoroughly cleaning all copper carbonate from the drill when seeding is finished. It is good practice to clean the drill of all seed and of as much dust as possible at the end of each day's work and to put the drill in the shed each night to protect it from moisture.

Two strengths of copper carbonate are on the market, and both give good results. Full strength dust (50 per cent metallic copper), used at the rate of 2 ounces per bushel of grain, probably gives somewhat the better results. The weaker product (20 per cent metallic copper) is used at the rate of  $2\frac{1}{2}$  to 3 ounces per

bushel. Copper carbonate especially prepared for seed treatment should be used. The finer it is ground the better disinfectant it is. The size of the dust particles is almost as important as the copper content of the chemical. To be effective, the dust must be



Fig. 46.—Oil drum mixer, for treating seed grain with copper carbonate and other dusts. (Photograph furnished by the author.)

fine enough to pass through a 200-mesh screen, but dust fine enough to pass through a 300-mesh screen is better.

A mechanical mixing machine must be used for copper carbonate, since each kernel must be coated thoroughly. The shovel method of mixing is not efficient enough for this dust. An oil drum, a commercial treating machine or a concrete mixer can be used.

**Formaldehyde Treatments.**—Formaldehyde, a gaseous disinfectant, has been used since 1897 for seed-borne diseases. It has proved especially effective in controlling the oats smuts. It is not effective, however, in controlling such diseases as barley stripe and loose smut of wheat.

For seed treatment, formaldehyde is now available as formalin, which is a liquid containing from 37 to 40 per cent of dissolved formaldehyde gas, and also as formaldehyde dusts. These dusts,

which are sold under proprietary names, contain from 4 to 8 per cent of formaldehyde gas adsorbed on the surface of the dust particles.

Formaldehyde has certain disadvantages. It irritates the mucous membranes of the operator. It may injure the seed, if it is used carelessly; and, because it leaves no coating on the seed, it does not give lasting protection against infection. It evaporates quickly, and treating solutions must therefore be used immediately after being prepared if they are to be effective.

Formaldehyde injury to seed results mainly from the penetration of the gas through the seed coat and into the germ. Such injury is especially apt to occur when treated seed is dried without being aerated. It can also occur as a result of absorption of the disinfectant by cracked kernels and even by sound kernels through broken seed coats. The lack of aeration that attends the sowing of treated seed in dry soil can result in severe seed injury; hence, it is advisable to keep treated seed moist until it is sown and to sow it in moderately moist soil.

Four methods of application are commonly used in treating cereal seed with formaldehyde: the spray, the sprinkle, the dip and the dust. The choice of method is governed chiefly by the kind of seed to be treated. The spray method is adapted only for the treatment of oats seed. The sprinkle and the dip methods can be used with all other kinds of cereal seed. Formaldehyde dusts can be used with all kinds of cereal seed for diseases susceptible to formaldehyde treatment.

The spray method, known as the "dry" formaldehyde method before the invention of the dust method, is the procedure most often used today. In this method, a solution consisting of 1 pint of full strength formalin and 1 pint of water is required for each 50 bushels of seed to be treated. An ordinary fly-poison sprayer that throws a fine mist is satisfactory for applying the solution. The cleaned seed is placed in a pile on the granary floor, a wagon bed or a canvas. As one man shovels the seed from this pile to another, a second man sprays the solution uniformly over the seed. Usually two strokes of the sprayer plunger are sufficient for each shovelful of grain. The pile of sprayed seed should be covered with canvas, blankets or sacks which also have been thoroughly sprayed with the same solution. It should be kept covered for at least 5 hours and may be left covered overnight. The seed can be sown immediately after treatment has been completed.



Seed can be treated by the spray method at any time prior to sowing if, after being treated, it is thoroughly aired before being bagged for storage. The bags used should be treated with the formalin solution to prevent recontamination of the seed.

In the sprinkle method of formaldehyde application, the solution usually recommended requires 1 pint of full strength formalin in 40 gallons of water for each 50 bushels of seed. The temperature of the water should be between 60 and 70 degrees F. An ordinary garden sprinkling can is satisfactory for applying the solution. The cleaned seed, spread out thinly and evenly on a smooth surface, should be sprinkled with the solution and then mixed by being shoveled until each grain has been thoroughly wet with the solution. The seed should then be shoveled into a pile, and the pile should be covered with canvas, blankets or sacks soaked in the same solution. The pile should be kept covered for at least 2 hours and may be left covered overnight.

Seed treated by the sprinkle method should be sown immediately after completion of the treatment, in a moderately moist soil. The rate of seeding must be adjusted on the drill to allow for the seed swelling that has occurred.

In a modification of the sprinkle method, a solution containing 1 pint of formalin in 10 gallons of water is required for each 80 bushels of seed to be treated. This solution is applied with a sprinkling can, as directed above, at the rate of 1 pint per bushel of seed. The seed is then mixed thoroughly, piled and covered as previously directed. The pile should be kept covered for 3 hours, after which the seed should immediately be sown or spread out in a thin layer to dry. If the seed is dried before being sown, occasional stirring of the seed as it dries will hasten escape of the gas and reduce the chance of injury.

The dip method of applying formaldehyde is the most dependable for the reason that, if carried out thoroughly, it insures the disinfection of every kernel. The solution required in this method consists of 1 pint of formalin in 40 gallons of water. The temperature of the water should be between 60 and 70 degrees F. The treating solution may be placed in a tank, a barrel or any other suitable container. The seed to be treated, after having been cleaned, should be placed in loosely woven burlap bags—the bags should be not more than half filled—and agitated in the solution until every grain is wet. The seed should then be drained, emptied from the bags and allowed to dry for at least 2 hours. It should be sown immediately in a moderately moist soil. If it

cannot be sown within about 12 hours after being treated, it should be spread out thinly to dry and should be stirred occasionally to hasten escape of the gas and prevent injury.

Wheat seed, because it is more susceptible to formaldehyde injury than oats seed, should be presoaked prior to treatment by the dip method. Each half bushel of cleaned seed, in a loosely woven sack, is soaked in water for 10 minutes, drained and set aside for about 6 hours. Then it is immersed and agitated in the treating solution for 10 minutes, removed, drained and set aside in the sack for another 6 hours. After this time, it should be emptied from the sack and spread out thinly to dry overnight. If seed is presoaked early in the morning, it can be treated at noon, spread out to dry in the evening and sown the following day. With this treatment, an adjustment of the drill must be made, increasing the indicated rate of seeding about 25 per cent. to compensate for the swelling of the seed.

Formaldehyde dust, like any of the other antiseptic dusts, can be applied to grain seed with a mixing machine or a gravity mixer. It has the advantage of being easier to apply than liquid formaldehyde. It gives off formaldehyde gas slowly and is therefore less apt to injure the seed than are the formaldehyde solutions. In using a formaldehyde dust, the grower should adhere strictly to the rate of application of the dust and all other instructions given on the package or in directions furnished by the manufacturer.

**Hot Water Treatments.**—Although the hot water seed treatment kills both external and internal seed infection, it is not recommended for general use because the average farm lacks facilities for performing the treatment satisfactorily. It is recommended, however, to producers of certified seed. If use of this treatment can be made a community project, every farmer in the community can have treated seed for his fields or at least enough treated seed to plant a seed plot from which disease-free seed can be obtained later. Local creameries often offer good facilities for treating seed by this method. The treatment may be used wherever the necessary tanks or vats can be assembled, if a boiler is available to furnish steam for heating the water used in the tanks.

Since the effectiveness of the hot water treatment depends upon raising the temperature of the seed high enough to kill any internal infection but not quite high enough to kill the seed germ, many of the weak and cracked seeds and those with broken seed

coats will be killed by the treatment. It is, therefore, necessary to test the seed for germination after it has been treated and increase the rate of seeding to compensate for the seed that has been killed.

There are two forms of hot water seed treatment, the long-soak or single-bath method and the modified or short method. The latter is the one generally used. Necessary equipment for either treatment includes a standardized, accurately graduated thermometer, a source of live steam to maintain water temperature and tanks large enough to accommodate the amount of seed to be treated.

In hot water treatment by the modified method, three tanks are necessary. Each tank is partly filled with water. The water in one tank is not heated, that in the second tank is maintained at 120 degrees F., and that in the third at 129 degrees F. for wheat and rye and 127 degrees F. for barley. The temperature in the second and third tanks must be kept as nearly constant as possible by live steam which is led into the tanks through hose or pipes and allowed to bubble up through the water.

Thoroughly cleaned seed, sacked in half-bushel lots in loosely woven 2-bushel sacks, is soaked in the cold water tank 4 to 5 hours, removed and allowed to drain. Next the seed is submerged and agitated in the second tank (120 degrees F.) 1 to 2 minutes to raise the temperature of the seed nearly to that of the third tank. The seed is then quickly transferred to the third tank and agitated in the water. If the temperature of the third tank has been maintained exactly as directed, the seed must be removed from the tank at the end of 10 minutes and cooled. Treated seed can be dipped in cold water, or emptied from the bags at once, spread out in a thin layer and stirred occasionally. The seed must, of course, be dried as soon as possible.

If the treatment is to be effective the temperature of the water in the third tank must not be allowed to fall below 124 degrees F. for wheat seed, or 125 degrees for barley seed. And it must not be allowed to rise above 131 degrees when treating wheat seed or above 129 degrees when treating barley seed, for temperatures higher than these will kill the seed. If the temperature varies from that recommended, it is necessary to vary the treating time accordingly. In the treatment of wheat, for example, if the temperature falls to 126 degrees, the seed should be soaked 15 minutes, but if it rises to 130 degrees the seed should be soaked only 8 minutes. Soaking the seed for periods longer

than those recommended is certain to result in serious seed injury; soaking for shorter periods reduces the degree of disease control obtained.

For the long-soak hot water treatment, only one tank is needed. The seed, sacked as directed for the short method, is immersed in hot water in the tank without having first been soaked in cold water. The temperature of the water may be maintained at either 120 degrees or 118.5 degrees F. At 120 degrees the seed should be soaked 1 hour and 35 minutes; at 118.5 degrees it should be soaked 1 hour and 50 minutes. When the treatment has been completed, the seed should be removed from the tank, emptied from the sacks, spread out thinly and stirred occasionally so that it will dry quickly.

**Organic Mercury Treatments.**—Certain organic mercury compounds, because of their high antiseptic value, are especially well adapted to the control of fungous and bacterial diseases of plants. For the control of cereal diseases, one of the most useful of these compounds, available as *New Improved Ceresan*, is prepared as a dust, the active ingredient of which is ethyl-mercury-phosphate. This chemical not only gives off an antiseptic gas which is immediately effective but also leaves on the seed an antiseptic coating which protects seed from decay and seedlings from blight. It can be used on all kinds of cereals and controls all seed-borne diseases except the loose smut of wheat. It gives exceptionally good control of barley stripe.

Although organic mercury dusts can cause seed injury if they are improperly used, they possess a number of advantages over the older materials. They cause no swelling of the seed, such as occurs with liquid treatments, and adjustment of the seeding rate on the drill is therefore seldom necessary. Because they are used in smaller amounts, they make less dust in the air to be inhaled by the operator while treating seed and handling it later. They do not interfere with the flow of seed through the drill, clog the drill or cause excessive wear of its parts. They can be applied to the seed of all the small grains with the same type of mixer.

Organic mercury dusts are poisonous. Seed treated with such dusts should never be used as human food or as feed for livestock. Treatment of seed should be done in the open or in a drafty place, so that the operator will not be compelled to inhale much of the dust. If possible the operator should wear a dust mask.

Mercury dusts should be applied at the rate recommended by the manufacturer. The ethyl-mercury-phosphate dust which

contains 5 per cent of that chemical is used at the rate of one-half ounce per bushel of seed. The dust should be applied to the seed with one of the mixing machines previously described, a gravity mixer or a commercial seed treating machine. If it is

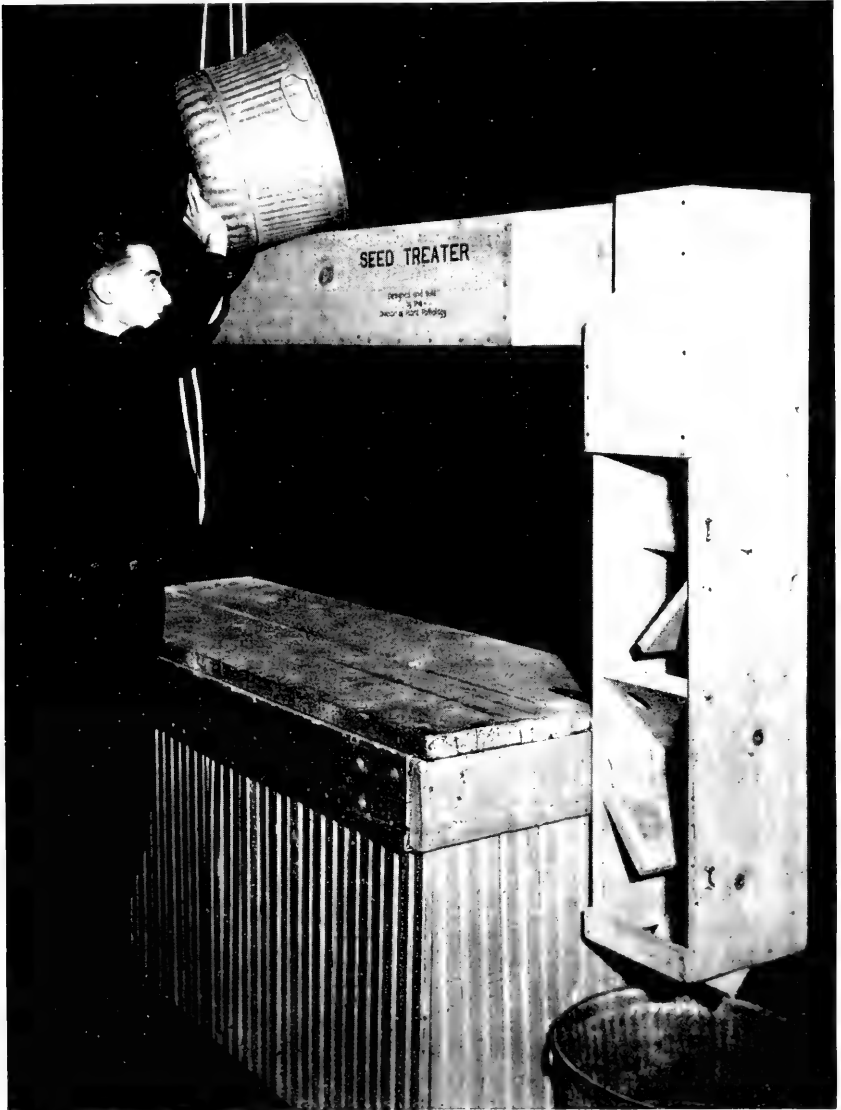

Fig. 47.—Minnesota gravity mixer, for treating seed grain with mercury dusts. (Photograph furnished by M. B. Moore, Minnesota Agricultural Experiment Station.)

impossible to apply the dust in any of these contrivances, the application can be made by hand, as follows: Spread a bushel of seed thinly on a flat, smooth surface and sprinkle evenly over it the required one-half ounce of dust; spread a second bushel of seed on top of the first and add the dust; repeat the process until all of the seed has been placed in the pile. Then shovel the entire pile over three or four times to mix seed and dust thoroughly. Let the pile stand for 24 hours before sowing the seed. A dust mask should always be worn by an operator using the hand mix method.

Some variations are necessary in handling the treated seed of different cereals to secure best results from the organic mercury dust treatment. Wheat seed should be treated at least 24 hours before it is to be sown and should be kept in a covered pile or in bags during that time so that the gas given off by the dust will be effective in killing surface-borne infection. It should not, however, be kept longer than two months before being planted. Barley seed should be treated at least 24 hours, preferably 72 hours, before being planted and should be kept in a covered pile or in bags during the intervening time. It can, however, be treated as long as six or eight weeks before planting time.

The injurious effects resulting from the storing of seed treated with organic mercury dusts can be prevented if the quantity of dust used per bushel is reduced in accordance with the length of time the seed is to be stored. For example, if seed is not to be sown for two days after treatment but is to be sown within a week, three-eighths ounce, instead of one-half ounce, of dust is sufficient for the treatment of each bushel, and if seeding is to be delayed for a week, one-fourth ounce of dust per bushel is sufficient.

Although liquid treatment with organic mercury compounds is widely used in plant disease control, it has little value in the control of cereal diseases, except as a supplement to the hot water treatment. For this purpose hydroxymercurichlorophenol, available as *Semesan*, is prepared according to the direction of the manufacturer (1 ounce of chemical in 3 gallons of water) as a 1 to 400 solution in cold water. Seed, after being removed from the hot water bath, is immersed in the cold organic mercury solution, which both cools the seed and aids in the control of surface-borne infections. The liquid organic mercury treatment also stimulates germination of the treated seed and thus compensates for the injury done by the hot water treatment.

1911  
1912  
1913  
1914  
1915  
1916  
1917  
1918  
1919  
1920  
1921  
1922  
1923  
1924  
1925  
1926  
1927  
1928  
1929  
1930  
1931  
1932  
1933  
1934  
1935  
1936  
1937  
1938  
1939  
1940  
1941  
1942  
1943  
1944  
1945  
1946  
1947  
1948  
1949  
1950  
1951  
1952  
1953  
1954  
1955  
1956  
1957  
1958  
1959  
1960  
1961  
1962  
1963  
1964  
1965  
1966  
1967  
1968  
1969  
1970  
1971  
1972  
1973  
1974  
1975  
1976  
1977  
1978  
1979  
1980  
1981  
1982  
1983  
1984  
1985  
1986  
1987  
1988  
1989  
1990  
1991  
1992  
1993  
1994  
1995  
1996  
1997  
1998  
1999  
2000  
2001  
2002  
2003  
2004  
2005  
2006  
2007  
2008  
2009  
2010  
2011  
2012  
2013  
2014  
2015  
2016  
2017  
2018  
2019  
2020  
2021  
2022  
2023  
2024  
2025











5701L6C  
CIRCULAR  
25-36 1934-47

C006



3 0112 017541183