

Dearborn, W. The domesticated silver fox.

(1917)

D

HARVARD UNIVERSITY.



LIBRARY

OF THE

MUSEUM OF COMPARATIVE ZOOLOGY.

45. 476

*Exchange.*

*March 26, 1917.*

MAR 26 1917

45,476

LIBRARY  
U.S. DEPT. OF AGRICULTURE  
BUREAU OF BIOLOGICAL SURVEY

# THE DOMESTICATED SILVER FOX

NED DEARBORN

Assistant Biologist, Bureau of Biological Survey



FARMERS' BULLETIN 795

UNITED STATES DEPARTMENT OF AGRICULTURE

Contribution from the Bureau of Biological Survey

E. W. NELSON Chief

Washington, D. C.

March, 1917

A

UNIVERSITY OF TORONTO LIBRARY

**F**OX FARMING, or as it is called in Canadian Provinces, "fox ranching," has attracted wide notice chiefly because of the enormous profits claimed for it. As would be expected in the case of a new and profitable business, many erroneous impressions have been entertained, the result of misleading statements made partly through lack of authentic information and partly with the purpose of interesting investors. When rightly undertaken, however, and with due consideration to climate, surroundings, and breeding stock, fox farming, and especially the breeding of silver foxes, frequently has proved profitable.

In the following pages are considered facts relative to the development of silver fox farming; the precautions necessary to be taken with the animals in breeding and in sickness and health; the construction of inclosures and nesting dens; the expenses of the business as well as its profits; and, in general, how and where fox farming may be undertaken with the promise of any degree of success. The distinction between red, cross, silver, and black foxes is explained and the relative values of the pelts discussed.

The softer and more beautiful furs naturally bring the higher prices, and few wild fur-bearing animals surpass the silver fox in this respect.

The lessening numbers of the animals in the wild state together with the increasing demand for their furs sound a warning that if this demand is to continue to be met it must be through domestication.

In certain cool climates the animals may be reared in captivity just as are domestic cattle and poultry. The areas suitable in the main for experiments in silver fox farming may be ascertained by reference to the map and its explanation on page 8.

## THE DOMESTICATED SILVER FOX.

### CONTENTS.

	Page.		Page.
Introduction.....	3	Propagation—Continued.	
History.....	5	Care of young.....	21
Climate.....	7	Behavior.....	22
Sites.....	7	Handling foxes.....	22
Inclosures.....	9	Health.....	23
Dens.....	9	Improved strains.....	25
Yards.....	11	Accessories.....	28
Guard fences.....	17	Marketing.....	29
Food.....	17	Costs.....	31
Propagation.....	20	Income.....	32

### INTRODUCTION.

From time immemorial furs have been worn for protection and adornment. With the increase of population and of encroachments upon the breeding grounds of fur-bearing animals the supply of furs has steadily diminished and prices have correspondingly advanced. Trappers have been stimulated to penetrate farther and farther into the uninhabited regions of the North and to redouble their efforts to increase their catch nearer home. Many of the more valuable animals have thus become so scarce that the demand for their pelts is met by the substitution of inferior products.

The natural production of first-class furs seems to be approaching a sure end, and the demand for them requires that the present supply be supplemented through domestication of fur-bearing animals. As some of the fur bearers may be raised without much difficulty, the establishment of fur farming on a small scale may be expected in many places along our northern border, much as poultry is now raised as an additional source of income on farms. When properly conducted, fur farming may become very profitable. It will pay not only in direct returns to the producer, but, indirectly, the desire for furs can be gratified, the killing off of the most valuable and interesting of our fur bearers prevented, and an extensive branch of manufacture and trade supporting a large population continued.

NOTE.—This bulletin, based on Department Bulletin No. 301, "Silver Fox Farming in Eastern North America" (1915), has been prepared to supersede Farmers' Bulletin No. 328, "Silver Fox Farming" (1908). It is for general distribution in areas shown by shading in the map on page 8.



The first American fur animal to be domesticated permanently was the silver or silver-gray fox (fig. 1), a rare and beautiful color phase of the common red fox<sup>1</sup> found in nearly all of the United States and Canada.

The relation of silver foxes to ordinary red foxes is the same as that of black squirrels to gray squirrels, or black muskrats to brown muskrats. That is to say, the black individuals are of the same species as those having the regular color. In a litter of fox cubs born of red parents, perhaps there may be one silver. On the other hand, one or more of the cubs of a wild silver vixen are quite certain to be

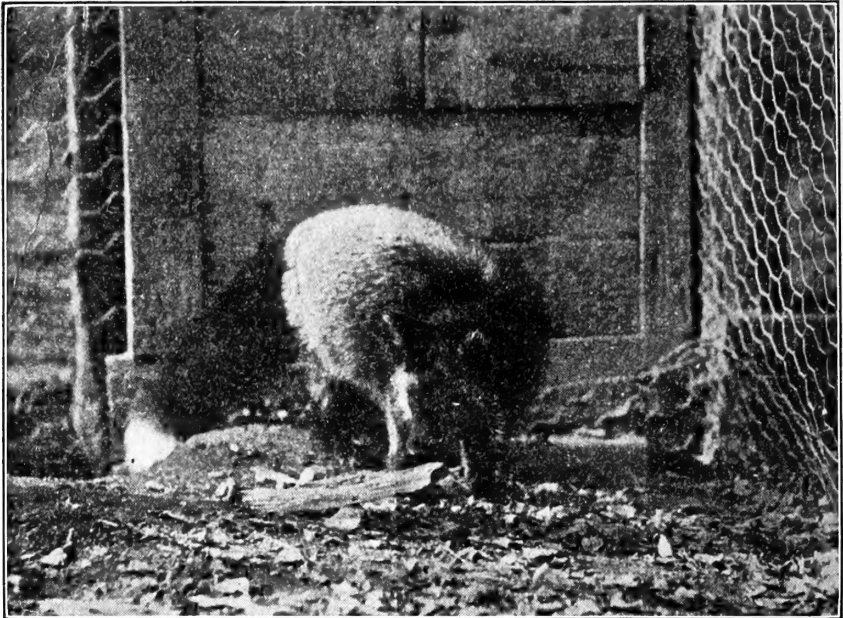

B629M

FIG. 1.—A silver fox bred in captivity. Note the tip of the tail, which is white in all phases of the ordinary red fox.

red. Fortunately, experience has shown that when silvers are bred in captivity the tendency to produce reds can be overcome by selective breeding.

The average red fox has the throat, breast, and belly white, and the sides and upperparts mainly red, this color being pure across the shoulders and on the nape of the neck but sparsely mixed with white on the back and sides. Close inspection discloses that the red and white are only on the surface, and that the fur beneath is almost black on the upperparts and dusky gray on throat and belly. It shows also that the fine hair or wool constituting the underfur is tipped with red and that, as a rule, the coarse guard hairs have a

<sup>1</sup> Genus *Vulpes*.

white section a little below the tip. Occasionally a guard hair is found that is entirely black. In the typical silver fox black replaces the red of the ordinary fox, the white of the guard hairs on the upperparts remaining constant. The result is a beautiful black, overlaid by a sprinkling of silvery white. Between the red and the silver phases there are grades of every degree, ranging from red-backed animals with black underparts through conditions characterizing cross foxes and rusty silvers. In rare instances even the white bars of the guard hairs are displaced, the result being a black or a silver-black fox. In general, the cross fox is fairly common, the silver-gray scarce, and the pure black very rare.

The market value of skins of the different phases depends upon the relative scarcity of the animals. The price paid for black skins, however, has recently fallen considerably below that of silvers, for the reason that furriers now dye ordinary red fox skins a lustrous black and put them on the market at a comparatively low figure.

#### HISTORY.

Domestication of the fox was first achieved in the Canadian Province of Prince Edward Island, in the Gulf of St. Lawrence. Silver fox pelts have continuously commanded high prices, and hunters have been correspondingly keen to secure them. It is not strange, therefore, that the first successful breeders of this rare animal were men who had pursued it in the chase.

In 1894 a ranch was built and stocked with two pairs of silver foxes. This became the first profitable fox ranch, the forerunner of a remarkable and, for that region, a revolutionizing industry.

At that time black pelts brought much higher prices than silvers. This prompted the first fox ranchers to retain their darker animals and dispose of the lighter ones, and as a result each successive lot of pelts from their yards was darker than those of previous years. Finally, in 1910, they were able to send to the London sales the finest collection of silver fox pelts that had ever appeared there. This lot, containing 25 pelts, brought an average of \$1,386 each, the best one selling for \$2,624. In the meantime a few other small ranches had been started in the Maritime Provinces, Newfoundland, Maine, Ontario, Michigan, and Alaska. The policy of the half dozen Prince Edward Islanders had been to monopolize the business, and not even their families were enlightened as to their methods. The pelts had been shipped three in a package by parcel post from a distant post office, and reports of the sales had been received in code. The fox raisers had entered into a compact to sell no live silver foxes and had bought the best that could be obtained. Notwithstanding their secrecy, the evident improvement in their financial conditions was noticed by their neighbors, who thereupon desired to participate.

Disclosure of the results of the 1910 sales was the climax of the first stage in the development of fox farming. Persons who formerly had known something of the business were now eager to engage in it. Those having money invested it in foxes. Others mortgaged their farms for the purpose or fitted up ranching facilities and boarded foxes for a share of the progeny. How rapidly prices for breeding stock advanced is well illustrated by the experience of one ranchman who sold his first pair of cubs for \$750, and other pairs successively for \$3,000, \$12,000, \$13,000, and \$14,000. In the fall of 1913 good ranch-bred cubs 6 months old sold for from \$11,000 to \$15,000 a pair. Pairs that had had large litters were valued at about twice as much as 6-months-old cubs.

The maintenance of this prodigious inflation of prices was due mainly to stock companies, which originally were formed by individuals without sufficient capital to engage in fox farming alone. Almost immediately, however, companies were formed for the benefit of those having foxes to sell. Attractive prospectuses containing pictures of silver foxes, an account of the 1910 sale of pelts, and a list of companies which had paid dividends of 20 to 500 per cent were published, and stock sold through brokers and solicitors. Foxes that would bring \$12,000 or \$15,000 a pair in the open market were usually capitalized in companies at \$18,000 or \$20,000, which, after allowing for commissions, installation of pens, and other ranch necessities, left a tolerably safe balance from which to pay the first year's running expenses. Another reason for the multiplication of fox companies is found in the income to be derived from them by brokers and promoters, and many companies were formed by men having no other interest. The outbreak of the European war, in the summer of 1914, interrupted and possibly ended these speculative operations. Ranch-bred silver foxes have recently been advertised for sale at from \$500 to \$1,000 a pair. In some of the western Provinces and Territories of Canada, where only those foxes born or kept for a year or more in captivity are allowed to be exported, prices of wild half-grown silvers run from \$150 to \$250 each.

In the pioneer days, when proper methods of handling foxes were unknown, many failures resulted from ignorance and carelessness. The excitement following the fur sales of 1910 hastened the improvement of methods of feeding, handling, and breeding. It also broke the monopoly, and caused a rapid distribution of foxes and of information concerning them. Now, with a comparatively large number of silver foxes in domestication, with a clearer understanding of their successful management, and with a return of moderate prices for breeders, a steady, healthy, and general development of silver fox farming may be expected.



Fox ranches are now established in most of the Canadian Provinces and in Maine, New Hampshire, Vermont, Massachusetts, New York, Pennsylvania, Ohio, Wisconsin, Michigan, Minnesota, Missouri, Oregon, Washington, and Alaska.

#### CLIMATE.

Fur growth is intimately related to climate. A long cold season and at least a moderate rainfall are important. Hot summers are not detrimental if short and followed by a season of frosty weather during which animals renew their coats. Dry winds tend to make fur harsh, and excessive sunshine fades it. The fitness of a locality for fox farming can be judged from the quality of fur produced by native wild foxes. While the proportion of silvers to reds varies greatly in different regions, this variation does not appear to depend on climatic conditions, and need not be considered in locating a fox farm.

The map of life zones shown in figure 2 indicates the regions having an average temperature favorable to fur culture, the cooler Canadian Zone being superior to the Transition Zone. Much of the region west of the Great Plains is included within these life zones on account of its high altitude, which makes it as cold as lower areas much farther north. While parts of this region possess the requisite degree of cold they are too dry and sunny for the production of first-class fur.

#### SITES.

One of the most important considerations in the choice of a site for a fox ranch is security from unusual noises and occurrences. The fox is naturally timid and nervous. It can be tamed to a degree, but its excitable temperment can be completely overcome only by a long process of careful breeding and selection. It is especially shy and irritable during the breeding season.

Foxes like to be screened from observation, and by day in the wild state are rarely found far from cover. During the heat of summer, especially, they enjoy dense shade. Furthermore, sunshine injures the color and character of fur. It is advisable, therefore, to locate a ranch among a growth of young trees thick enough to shade about half the ground. Deciduous trees are preferable to evergreens, as they allow the sun to make the yards more comfortable in winter and to clear the ground of snow earlier in spring. Old trees are likely to be broken by storms, and in falling to demolish fences.

On a slope with a southern exposure the snow will be gone and the ground warm when the cubs are ready to leave the dens. A clay sur-

face is to be avoided, but a subsoil of clay or hardpan is an advantage, as the foxes will not dig ground hard enough to require a pick to

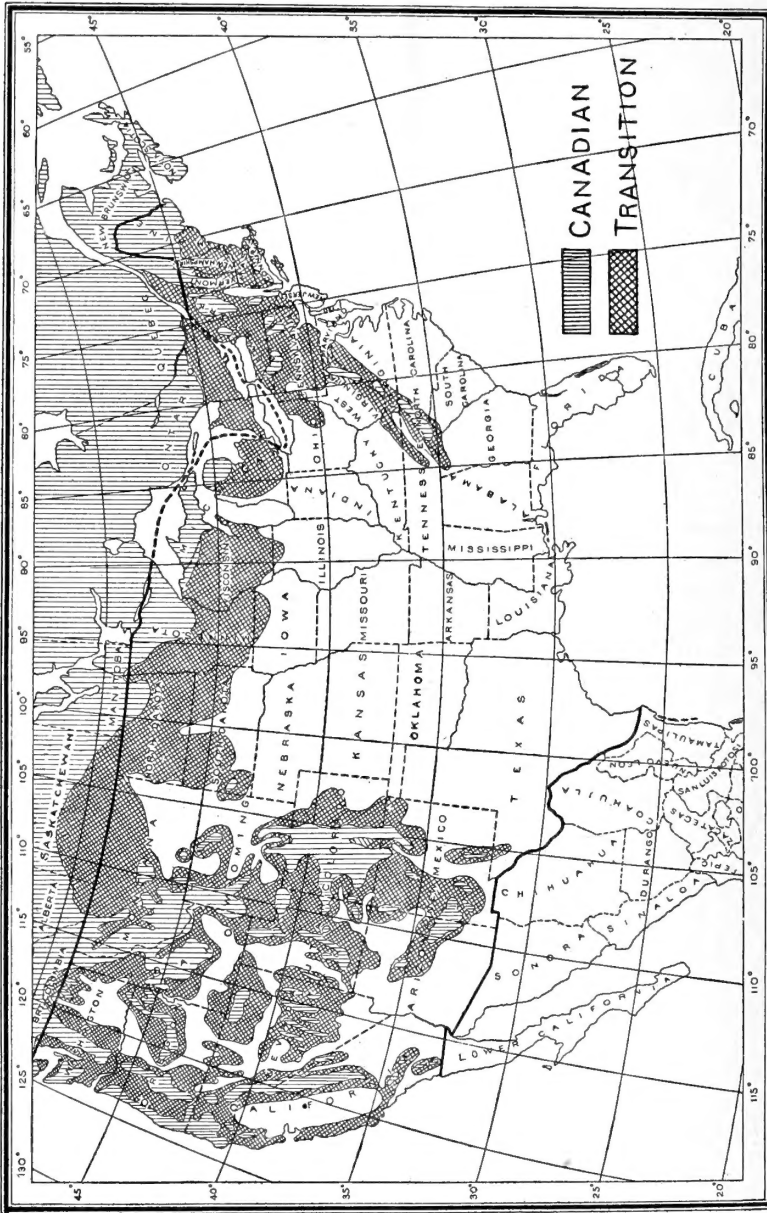

FIG. 2.—Map of life zones in which fox farming is feasible in the United States, showing the Canadian Zone, where conditions are excellent, and the Transition Zone, in parts of which conditions are favorable.

break it up. Gravel affords excellent drainage, but foxes burrow deeply in it and thus are difficult to manage, even though they may not escape.

## INCLOSURES.

A model fox ranch has three kinds of inclosures—dens in which the animals are sheltered and the young are born; yards or runs, where they may have sunshine and shade and sufficient exercise to keep them in good health; and a guard fence surrounding the entire ranch, for the double purpose of preventing intrusion from without and escape from within.

## DENS.

The walls of a fox den should exclude moisture, deaden sounds, and protect the occupants from extremes of heat and cold. During the breeding season, when foxes are unusually nervous and when the cubs can not withstand exposure, these features are particularly important. Pro-

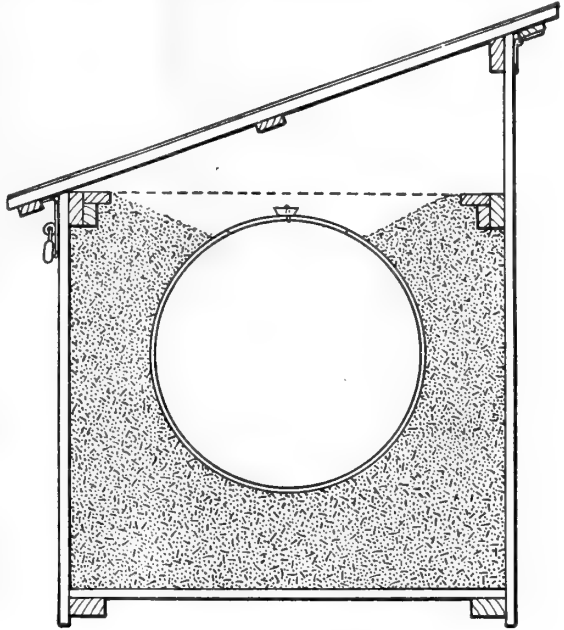

FIG. 3.—Vertical cross section of a barrel den.

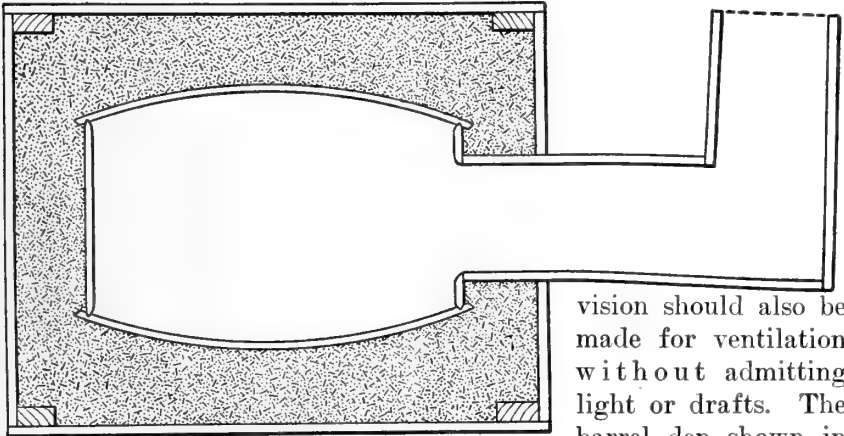

FIG. 4.—Horizontal longitudinal section of barrel den.

vision should also be made for ventilation without admitting light or drafts. The barrel den shown in figures 3 to 6 is merely a clean barrel, having a smooth interior, surrounded by dry sawdust, within a wooden box. In one head of the barrel is an entrance hole 8 inches wide and 10 inches high. A similar

opening is made in the upper side for inspection, cleaning, and ventilating. Above the barrel a screen door is hinged to preclude

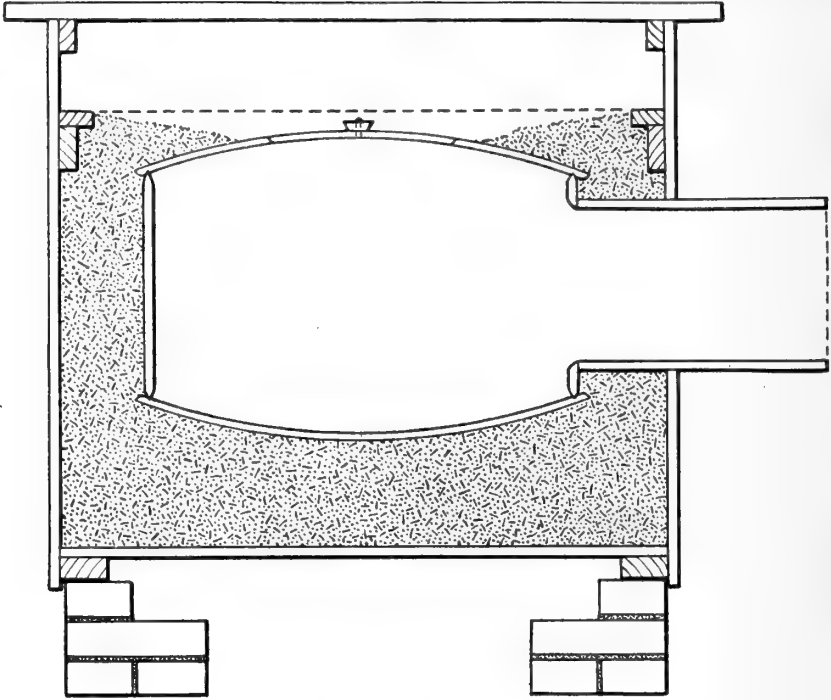

FIG. 5.—Vertical longitudinal section of barrel den.

escape when the cover is raised. A sheet of burlap tacked to one side of the screen-door frame and spread over the netting when the covers are raised for ventilation will keep out air currents and light. At the entrance hole is an elbow spout,  $2\frac{1}{2}$  feet in the shorter arm and 6 feet in the longer.

The large den shown in figures 7 to 9 has advantages not found in barrel dens. It has double walls, the interspaces being lined with building paper and filled with sawdust. The exterior may be battened, shingled, or covered with tarred paper. It is large enough to give the foxes lounging room outside the nest compartment, and is arranged so as to

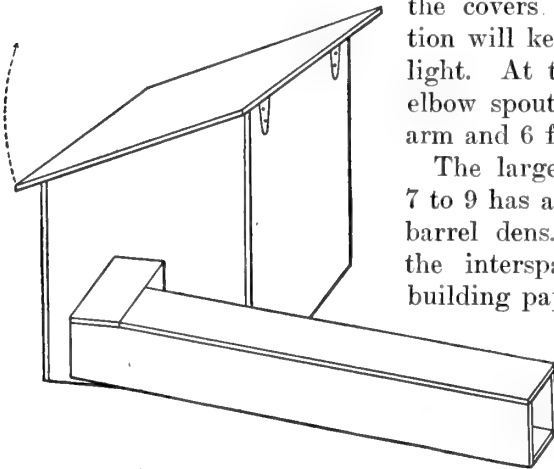

FIG. 6.—Exterior view of a barrel den (see figs. 3-5).

ing room outside the nest compartment, and is arranged so as to

be easily cleaned and disinfected. By leaving the door open on fine days the interior can be exposed to the drying and purifying effects of sunshine. The door and the opening to the exit chute should face southward, and the rear end should be raised enough to give the floor a slant downward toward the door. The entrance to the nest compartment and the inner end of the chute should be about 4 inches above the floor to prevent the cubs from getting out before they are able to return.

The corners along the floor and sides of the nest compartment are filled with a chamfered strip of board (figs. 7 and 8) to keep very young cubs in contact with the vixen and thus prevent their becoming chilled. To accommodate a large family of cubs running about the yard, it is advisable to have extra dens improvised from barrels or boxes, as shown in figures 10 and 11. Such shelters increase the diversity of the yard and afford the animals more protection from the weather.

As to the proper location of a den, opinions differ. Some place it near the middle of the yard (fig. 12), where the foxes are supposed to feel more secure. Others locate it outside the yard, in order that the vixen may not jump to and from the roof and thus cause abortion. All dens placed outside of yards should have an inner door of wire netting if they open to an alley.

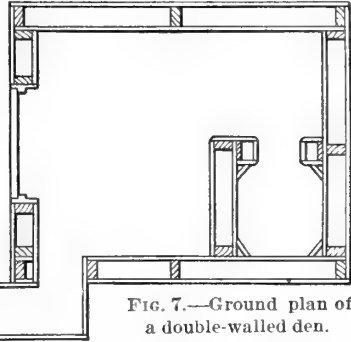

FIG. 7.—Ground plan of a double-walled den.

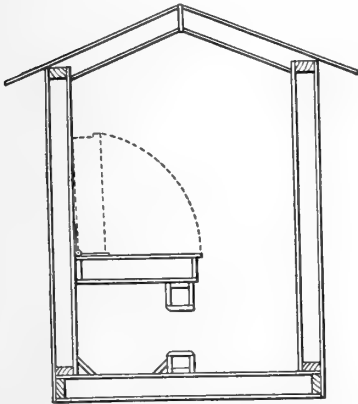

FIG. 8.—Vertical cross section of double-walled den.

#### YARDS.

Although fox yards vary in size, shape, and construction, depending on conditions on different ranches, there is a definite type now generally recognized as best adapted to fox farming. Such a yard has an area of from 2,000 to 2,500 square feet. The majority in the recently built ranches are 50 feet square. Some breeders prefer long, narrow yards, which give the foxes more space for a hard run when they are frolicsome, though the cost of fence materials is considerably greater than for square yards of the same area. The arrangement of a series of yards depends upon the space they are to occupy. When arranged as nearly as possible in the form of a square the expense of



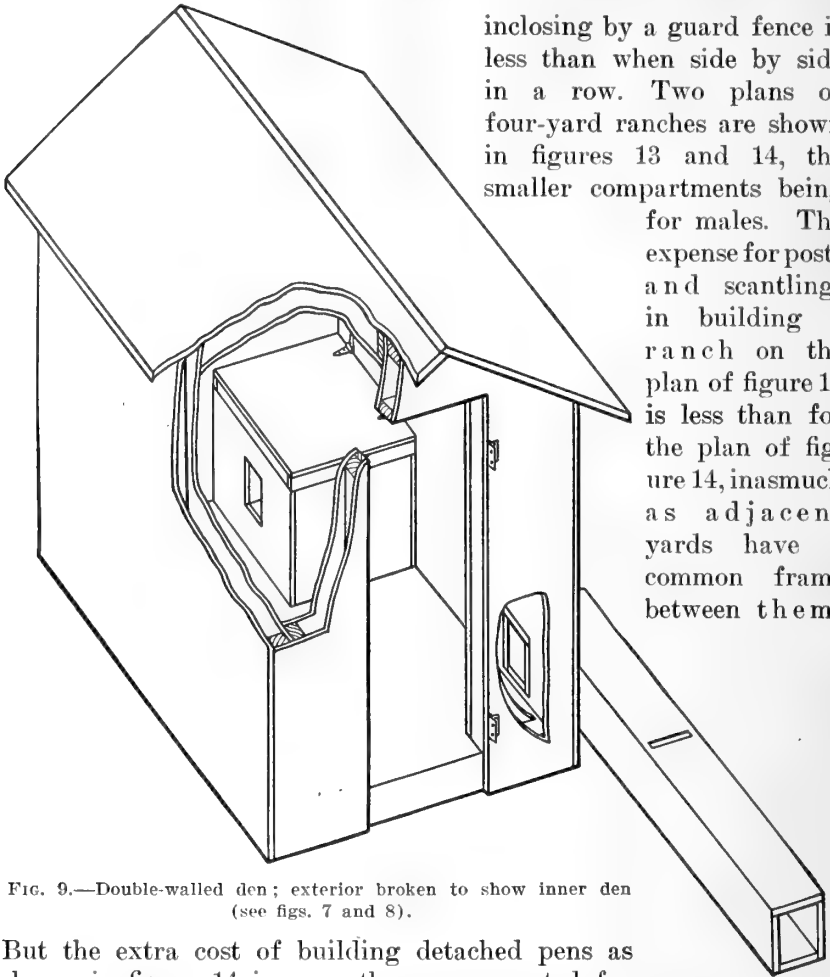

FIG. 9.—Double-walled den; exterior broken to show inner den (see figs. 7 and 8).

But the extra cost of building detached pens as shown in figure 14 is more than compensated for by the greater convenience in caring for the animals and in controlling them in case they escape from their yards. If a fox gets out of its yard, it is sure to be discovered in one of the alleys, whence its return to its proper quarters is a simple matter.

The supports of a fence are ordinarily wooden posts, set in the ground at intervals of from 12 to 16 feet. The heaving effect of frost, however, has caused

many fox owners to abandon them for a framework of scantlings entirely above ground. The foundation may be of stone, concrete,

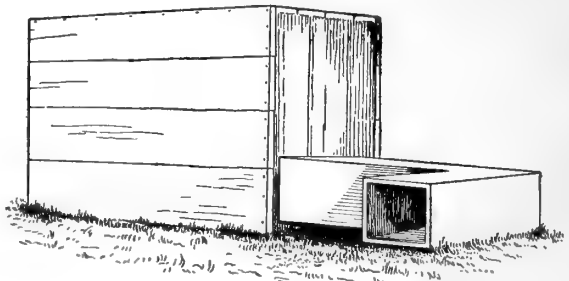

FIG. 10.—Den improvised from a box.

inclosing by a guard fence is less than when side by side in a row. Two plans of four-yard ranches are shown in figures 13 and 14, the smaller compartments being for males. The expense for posts and scantlings in building a ranch on the plan of figure 13 is less than for the plan of figure 14, inasmuch as adjacent yards have a common frame between them.

or crested planks. The posts of framed fences are tied together by the netting and braced from the ground as shown in figure 15. A durable and attractive fence support recently adopted by several fox owners is shown in figure 16. It has a concrete foundation 4 feet deep, 9 inches thick at the bottom, and 6 inches thick at the top, and projects slightly above ground. In this are embedded posts of 1-inch galvanized-iron pipe. Tie-rails of  $\frac{3}{4}$ -inch pipe connect these posts at the top and also just above the foundation.

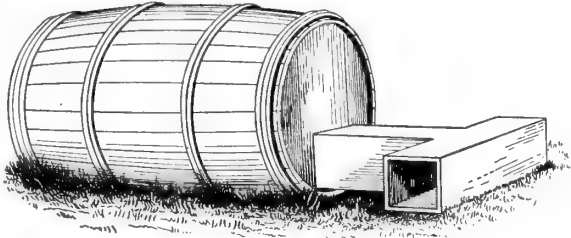

FIG. 11.—Den improvised from a barrel.

Wire netting for fox-yard fences has been in use from the beginning. It allows free circulation of air and permits the animals to take an active interest in their surroundings and in one another. The netting ordinarily used is like that for poultry runs, except that



B630M

FIG. 12.—An inexpensive type of den. Table in foreground is for the food of parent foxes; by means of it young cubs are prevented from obtaining too much meat.

the wire is heavier. It may be of 2-inch mesh in 14, 15, and 16 gauge. The lower part of a fence should be made of the heaviest wire obtainable, the lighter grades being used for the middle and upper parts. As very young foxes are likely to become entangled in 2-inch netting or even to go through it, many fox breeders use only  $1\frac{1}{2}$ -inch mesh. Those having 2-inch mesh usually reinforce it from 6 inches above the surface of the ground to 6 inches below it with boards or a strip of 1-inch netting.

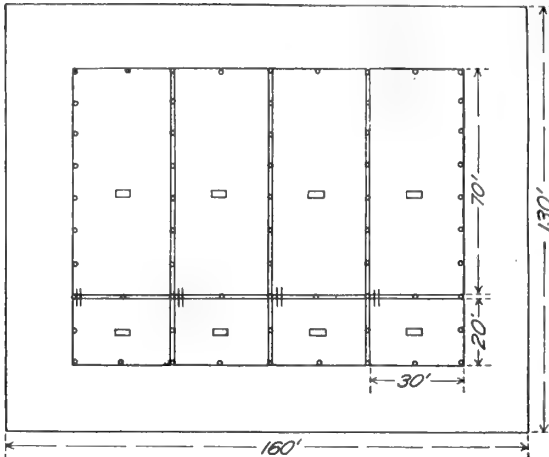

The disposition of foxes to take an adversary at a disadvantage has led to serious injuries when adjoining yards were separated by only a single partition of coarse netting. In a number of instances a climbing animal has had its foot seized, pulled through the fence, and held by the occupant of the next yard until its frantic

FIG. 13.—Plan for rectangular yards in series; dens with yards.

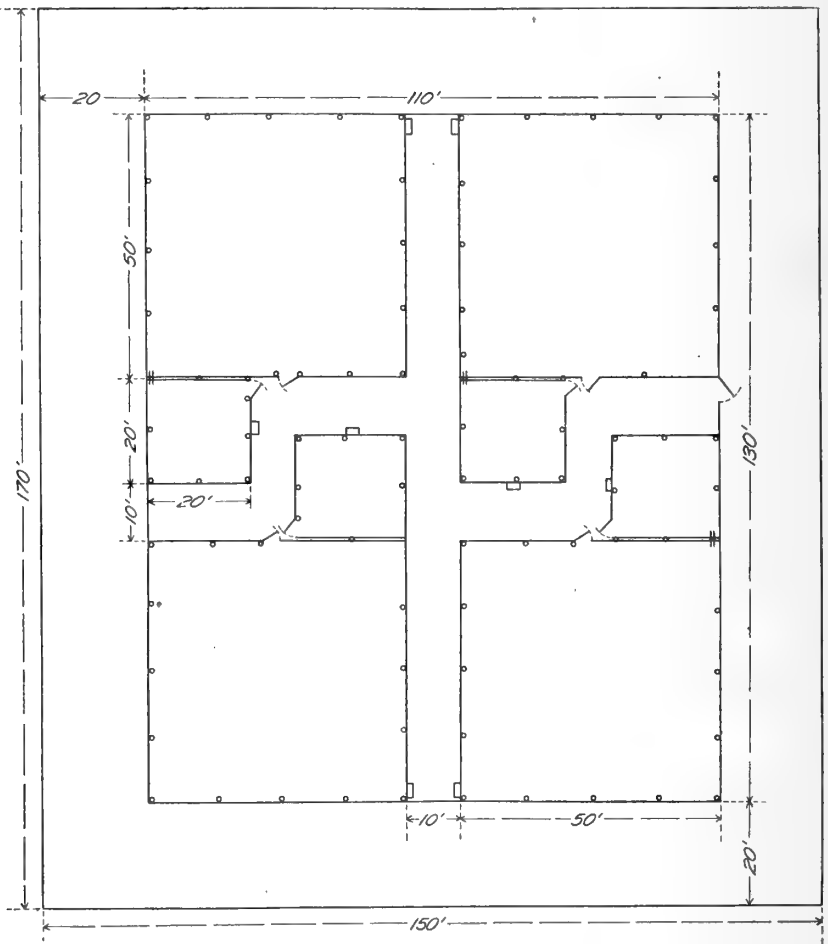

FIG. 14.—Plan for square detached yards; dens and doors in alleys.

struggles to escape resulted in a badly mangled leg. Such accidents can be avoided by making double-walled partitions, the walls separated by at least 4 inches, or single-walled partitions of 1-inch netting or of boards. The necessity of erecting double partitions is overcome, however, by use of the plan illustrated in figure 14.

The height of a fence depends somewhat upon the depth of the snowfall. In Maine and the Maritime Provinces the usual height is 9 or 10 feet, while in Laborador it is 12 feet. To prevent foxes from digging out, the fence is either extended into the ground (fig. 17) or

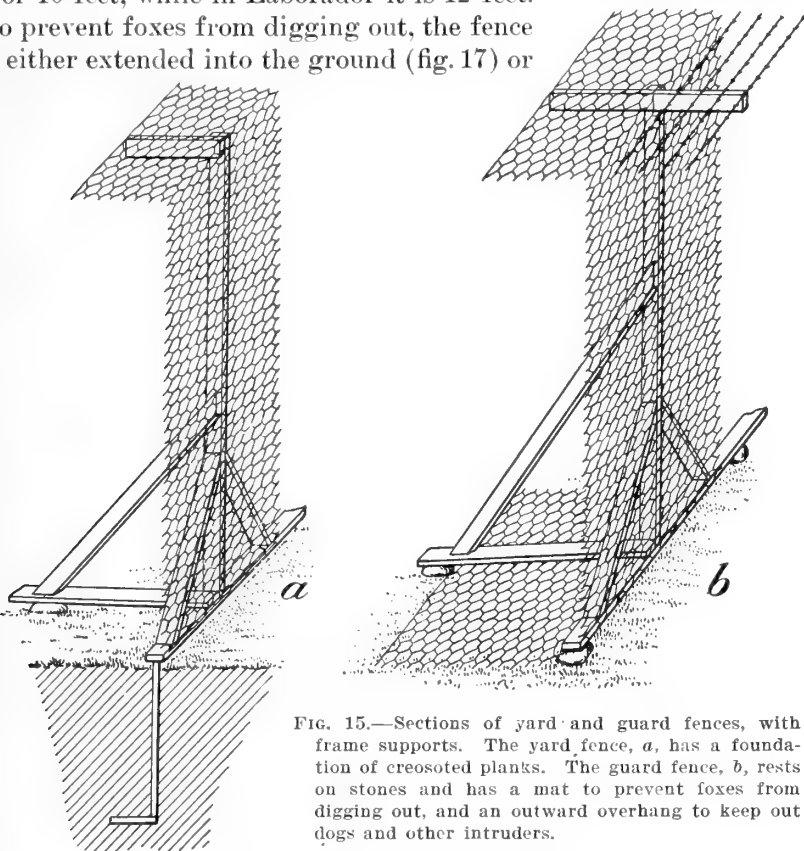

FIG. 15.—Sections of yard and guard fences, with frame supports. The yard fence, *a*, has a foundation of creosoted planks. The guard fence, *b*, rests on stones and has a mat to prevent foxes from digging out, and an outward overhang to keep out dogs and other intruders.

turned abruptly inward at the surface (fig. 18) to form a mat 3 feet wide, the inner edge of which is pinned firmly to the ground and usually covered with earth or stone. A fence extended into the ground must reach a depth of 4 or 5 feet if the soil is soft, and be turned inward a foot at the bottom. If there is a subsoil of clay or hardpan, the fence need not enter it more than 6 inches. Instead of netting, the underground part of a fence may be made of 2-inch creosoted planks. As foxes climb wire fences readily an inward overhang about 18 inches wide should be placed at the top to prevent escape (figs. 15–20). When a fox has scrambled up to an overhang,

its only means of descending is by falling. Sometimes valuable animals have been seriously injured in this way. To prevent accidents of this kind an intermediate overhang is sometimes constructed 5 feet from the ground, as shown in figure 16, or a smooth zone of boards or sheet iron is inserted in the upper half of the fence, as shown in figure 20.

The yards for sequestering males are usually adjacent to the main yards, with which they are connected by a chute having a sliding door (fig. 21), though sometimes they are separated from the family

yards. It is advisable to have them roomy, as indicated in figures 13 and 14, in order to give the animals enough runway to make them vigorous during exile. When allowed to be together the pair may have the run of both yards. Although quarters for constant occupancy should be roomy, those for temporary use, such as are required by dealers and ranchmen for isolating sick or newly arrived animals, may be comparatively small. Temporary pens are

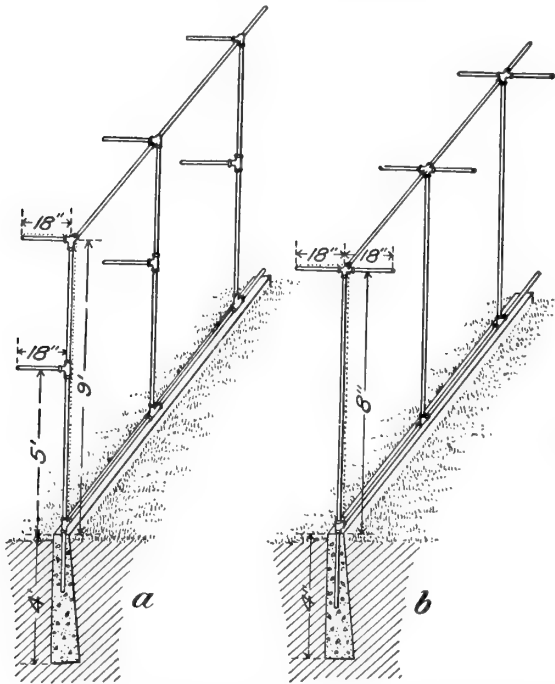

FIG. 16.—Iron posts and concrete foundations for yard fence, *a*, and guard fence, *b*. Note the 18-inch overhangs, two on the yard fence, one of which (5 feet from the ground) is to prevent foxes from climbing to the top and the resulting injury from the greater fall.

often not more than 6 by 10 feet on the ground and 4 or 5 feet high. They are made with netting on top, bottom, and sides, stretched over a frame of scantlings. The posts do not enter the ground, but rest upon sills, to which they are securely nailed. By means of braces the frame can be made rigid, and when covered with netting is strong enough to be moved without weakening. The cheapness, security, and portability of these pens make them a very useful adjunct. Foxes have bred and reared young in temporary pens that were only 12 by 15 feet, but such narrow quarters are not recommended for permanent use.



When alleys are used between pens, as shown in figure 14, it is well to have them closed at the outer ends to facilitate the return of escaped animals and provided with overhangs. Entrance to the yards should be by way of these alleys.

Doors may be made entirely of wood, or of netting attached to a durable frame which can not be gnawed by a fox or warped (fig. 19). If they are divided into upper and lower sections of equal size, much of the labor of clearing paths when snow is deep can be eliminated by leaving the lower half of each door closed.

#### GUARD FENCES.

The guard fence surrounding a fox ranch is generally constructed like the yard fences already described. Where snow drifts badly the fence should be built of boards rather than netting, in order to keep the snow from piling up in the yards. In addition to the usual inward overhang, it should have an outward overhang of barbed wire to keep out dogs and other intruders (fig. 15).

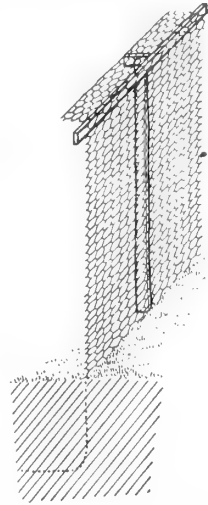

FIG. 17.—Fence extending into the ground.

#### FOOD.

The natural food habits of foxes are similar to those of dogs. Birds, mice, rabbits, and other animals are eaten, as well as grasshoppers, crickets, and other insects, eggs, and many kinds of berries. In short, the animals are practically omnivorous.

The rations of domesticated foxes include beef, horse meat, mutton, veal, woodchucks, rabbits, liver, fish, eggs, milk, bread, mashed potatoes, crackers, mush, dog biscuit, boiled turnips and carrots, and fresh fruits. The selection of meats is largely a matter of circumstances. At irregular and uncertain intervals one may obtain injured or worn-out but otherwise healthy horses, or old sheep that can not be fattened for mutton, and these, when slaughtered, make good and cheap meat. Woodchucks and rabbits, freshly killed, are always welcome in a fox yard. When cheap meats fail, beef and poultry are used.

Fortunately, foxes do not need meat every day. Some keepers feed it but two or three times a week. Young foxes are not allowed

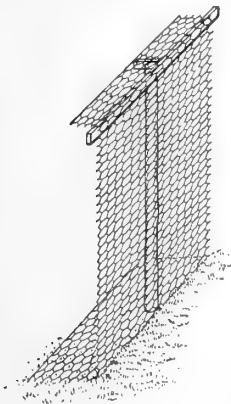
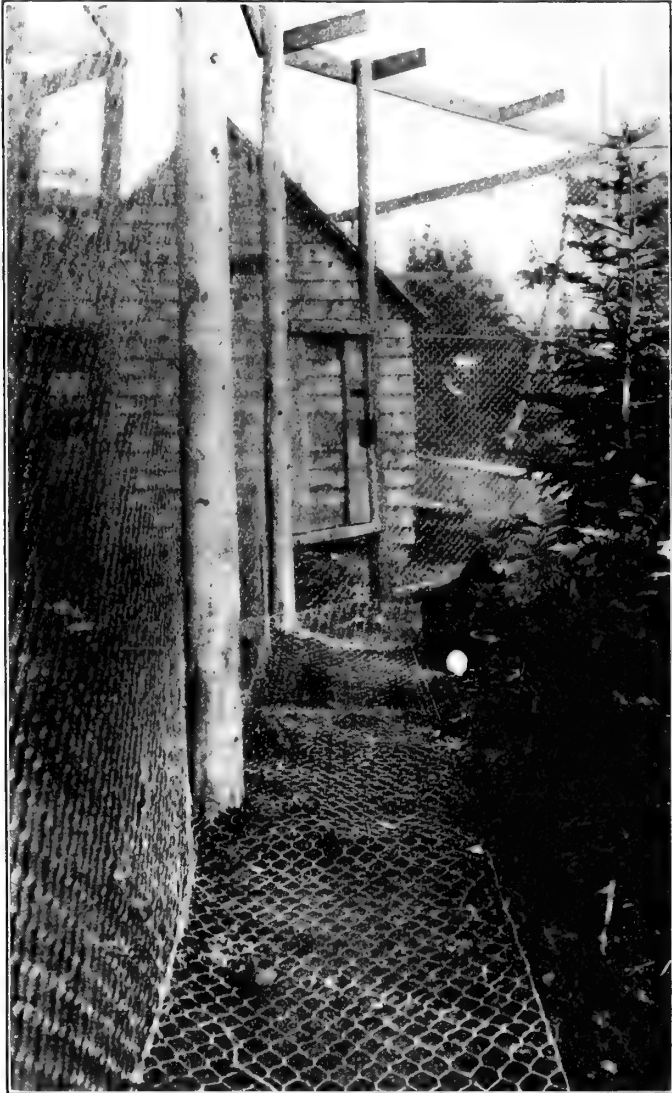

FIG. 18.—Fence turned inward at surface of ground to form a mat.

meat until they are four months old, as it is likely to cause rickets. Meat intended for a brood vixen may be fastened to the top of a table out of the reach of her cubs.



B631M

FIG. 19.—Details of entrance, mat, and overhang of a fox yard.

Milk, with some sort of bread or cooked mush, is the standard food for old and young. Foxes, which are fed twice a day, usually have meat in the morning and bread or mush and milk at night. In summer the proportion of meat is less than in winter. When smelts or trout can be had they are frequently substituted, but fish is not con-

sidered good for foxes in warm weather. Coarser fishes are sometimes used, but are not very much in favor. It is not deemed well to feed milk and fish on the same day. Milk and eggs are often given to females about the time cubs are expected, to strengthen them, relax their bowels, and allay fever. Fish, liver, and tripe are other laxative foods which may be used instead of milk and eggs. A diet of eggs, milk, mush, and wheat bread without leaven or salt is excellent.

The preparation of food for foxes deserves careful attention. All dishes should be kept clean. Meat that is diseased, tainted, or infected with parasites must be boiled. It is better to skin rabbits, as their hair readily felts and sometimes forms in balls in the stomachs of animals which feed on them. Their heads and entrails also should be removed, as these parts are frequently infested with parasites. Smelts and small trout may be fed whole, but larger fish should be dressed and the backbones removed. Chilled meat should be warmed before being offered to cubs or nursing females. Oatmeal or cornmeal mush should be thoroughly cooked. All food for sick animals should be cooked to make it more digestible and to free it from disease germs.

Foxes should be fed regularly twice a day, morning and evening. This is especially important in hot weather, as whatever is left from the first meal will spoil before time for the next. By giving at each feeding only the proper quantity the injurious effects of gorging can be avoided. Overfeeding is more dangerous than underfeeding.

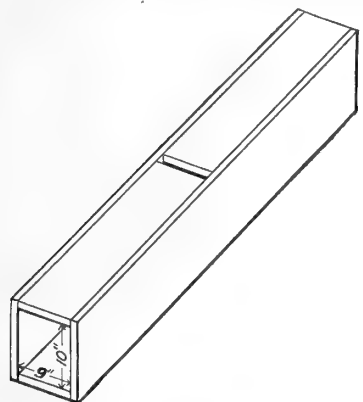

FIG. 21.—Chute for connecting yards. It can be closed by inserting a sliding door in a slot.

thin throughout the summer and up to about the first of January, when their rations are increased to prepare them for the breeding season.

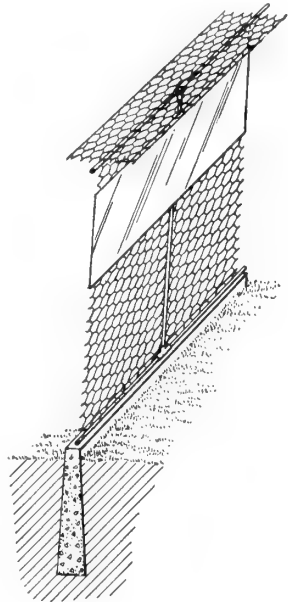

FIG. 20.—Section of a fence containing a smooth zone to protect foxes from injury from falling. Concrete foundation and iron posts.

Foxes that are to be slaughtered for their pelts are well fed during the autumn months, as the finest skins usually come from fat animals. Brood animals, on the other hand, are kept

### PROPAGATION.

Foxes mate in February or March. The mating season is often revealed by a brownish discharge and may last anywhere from a few hours to two or three days. The gestation period is about 51 days. The size of litters ranges from one to nine, the average being about four. Each male remains faithful to the vixen of his choice and is an exemplary husband and father. During the first few days after the cubs are born the vixen remains in the den. Meanwhile her mate brings her food and remains constantly in the vicinity to apprise her by warning barks if an enemy approaches. Attempts have been made by fox breeders to mate one male with several females in the same season, but, as a rule, the results have not been encouraging.

Males are removed from the breeding yards for a part of each year, the length of their exile depending upon the relations of the pair. If they are quarrelsome, it is best to separate them soon after the female becomes pregnant. If, on the contrary, they agree and show attachment to each other, it is wise to keep them together until the cubs are four weeks old, but after that the male is likely to bite them during scrambles for food at meal times. While sequestered, the males are usually kept in small pens which may adjoin the breeding yards, as shown in figures 13 and 14, or removed to a separate inclosure, where they may be allowed to run together in a large yard or confined in individual pens. Because of their inclination to fight, individual pens are preferable.

The reproductive period in foxes is about 10 years. Approximately 50 per cent of the females in domestication breed each year, and the aggregate increase is not far from 100 per cent for the total stock on ranches. Failure to breed is attributable to a variety of causes, among which are sterility, injuries, worry, and mismating. Females barren for two years in succession frequently become productive on being mated to a different male. Prolific vixens, run down by several litters in succession, sometimes skip a year in which to recuperate.

The excitable disposition of foxes is one of their most troublesome characteristics, and no opportunity should be lost to abate it. In the breeding season it is very essential that nothing shall occur to make them apprehensive. A nervous vixen is likely to refuse the attentions of her mate, or to injure herself and cause abortion, or, what is still more probable, to destroy her young soon after they are born, by neglect, or by taking them from the warm den and carrying them about the yard in search of another hiding place. In her extreme anxiety she loses all her instinctive prudence. She becomes essentially insane, and only the closest attention on the part of her keeper can save her cubs.

From the time the cubs are born until they are two or three weeks old constant care must be taken to prevent losses in this manner. Any unusual sight, sound, or odor, by day or night, is liable to alarm a vixen and cause her to maltreat her young. The best way of dealing with a worried vixen is to shut her with her cubs in the den for several hours or until she becomes pacified. If she is disturbed by the proximity of other foxes, as sometimes happens, her view should be limited by boarding in the lower 2 or 3 feet of her yard.

#### CARE OF YOUNG.

Young foxes are subject to other troubles which, unless corrected, often prove fatal. They may be infested with external or internal parasites, or their mothers may not have enough milk to nourish them properly. It is very important that their condition from day to day be known. But the great value of the cubs and their danger from the irritability of their mothers generally cause the keeper to refrain from looking into the dens. By watching the behavior of the mothers they judge whether the young are doing well. It has been demonstrated by at least one progressive keeper that this uncertainty is by no means necessary. Foxes are not excited by routine events. By giving them large two-room dens, similar to the one shown in figure 9, and always feeding them in the outer compartment, they are led to expect the entrance of the keeper as the regular preliminary to each meal, and even to welcome it. When the keeper enters, they, of course, depart, leaving him free to look into the inner den. He should not touch the cubs unless they need attention.

The young are small and weak at first, and their mother remains with them almost constantly for the first three days. They grow rapidly and usually begin to appear outside the den in about a month. When 6 weeks old they eat more or less solid food. After this they may be weaned. Many breeders leave the weaning entirely to the vixen unless she is becoming emaciated. A decided advantage in weaning cubs when they are 6 or 8 weeks old is that when the keeper controls their food he can more easily eradicate the intestinal worms which usually infest them. Care should be taken to keep early-weaned cubs clean and dry. In case of accident to a mother fox, cubs may be reared by cats almost from birth. Not more than two cubs should be given to one cat. After they are about 3 weeks old their teeth become large and sharp enough to lacerate their foster mothers, and they must be reared by hand.

The taming and training of the foxes when pups tends to the production of adult animals which are much more valuable for breeding purposes. That attempts to tame pups may meet with some degree of success is well shown in the illustration on the title page.



### BEHAVIOR.

During the day, particularly in fine weather, foxes are generally quiet, staying either in their dens or curled up among the branches of a tree or upon a shady platform several feet above the ground, whence they can see all that goes on around them. Late in the afternoon they arouse and until morning engage in a variety of activities. Sometimes they run and caper joyfully; sometimes when the soil is soft and the yards are not floored they dig, although animals accustomed to captivity rarely show a determined effort to escape by this means. When suddenly frightened they often attempt to escape by climbing the fence.

In the majority of fox yards the inmates skulk and hide whenever anyone approaches, although ordinary travel along a thoroughfare a hundred yards or more away gives them no apparent concern. All moving objects interest them keenly. Birds alighting within their yards often fall prey to their agility. Among themselves they are generally at peace, but a flash of treachery is likely to be displayed whenever one animal finds another at a disadvantage. One fox will seize and mangle another's foot that has been carelessly placed on the intervening fence, or will maim or kill a neighbor's cubs.

The natural timidity of foxes can be largely dissipated by special efforts to domesticate them in the full sense of the word. By weaning them early and thereafter feeding them from the hand, they usually become gentle and attached to their pens. When animals escape they sometimes return of their own accord or allow their keepers to capture them without difficulty. For example, a tame red fox after being liberated from a ranch maintained for cross and silver foxes went to live in the woods but presented himself early each morning at the gate of the ranch to be let in for a visit with his former comrades. After a time he commenced a burrow on a dry knoll in one corner of the outer yard and devoted half an hour daily to its extension. Although his career was, unfortunately, cut short by a trapper, he lived long enough to indicate very clearly that the wildness of foxes can be modified or even overcome.

### HANDLING FOXES.

Unless foxes are diseased or injured, it is rarely necessary to lay hands on them. When one is to be removed from its yard, ordinarily it can be first driven into its den and thence into a small handling box having a sliding door at one end and strong wire netting covering one side. In this manner it can be transferred without danger of injury to itself or its keeper. It is best to darken the handling box by covering it or by turning the netted side downward on the ground before attempting to drive a fox into it. In actually

handling grown foxes it is prudent to wear gloves to guard against being bitten, though this precaution is not always adopted by experienced keepers. An effective device for catching foxes is a pair of tongs with jaws curved to form a circle  $2\frac{1}{2}$  inches in diameter. The fox is first driven into its den or into a large covered box. Then the cover is raised barely enough to let the tongs pass in and grasp the fox around the neck. By holding the tongs in one hand and grasping the hind feet and tail of the fox with the other, the animal can be held securely.

Healthy foxes if properly boxed and cared for can be shipped safely almost any distance. Two foxes, or even more than two, are sometimes shipped in the same compartment, but this is inadvisable unless the distance is short. As a rule, a box containing two should be partitioned, each animal having a space equivalent to 2 by 3 feet on the floor and  $1\frac{1}{2}$  feet high. About half of one side of the box should be removed and the opening covered with wire netting to allow ventilation and inspection. Shippers often cover the entire box with netting or tin to preclude the possibility of escape. A dish for water should be fastened to the floor close to the front, where it can easily be filled. Foxes are not usually injured by a fast of three or four days, but they should not be allowed to suffer from thirst. Express companies, if duly instructed, will feed animals en route and add the cost to the regular transportation charge. In case the animals are very valuable or are to be shipped a long distance, an attendant should accompany them.

#### HEALTH.

Generally speaking, sickness is not common among domesticated foxes that are well cared for. Once in a while one breaks a leg as the result of a fall or, more often, from entanglement in wire netting having too coarse meshes. Lacerations rarely result twice from the same cause or from fighting. Even more rarely is a fox choked while eating. Passing meat and small or soft bones and cartilage through a bone grinder will not only prevent choking, but allow enough bone to be fed with the meat to produce sturdy animals. Simple fractures, uncomplicated by abrasions, will mend if untouched, but it is better to bind splints upon the wounded limb to keep it in proper shape, and then to apply iodoform to prevent the animal from tearing them off. When a bone is badly shattered, and especially when it protrudes, the leg should be amputated. Anesthetics are likely to kill foxes and hence should not be used. Flesh wounds ordinarily require no attention other than washing once or twice a day in warm carbolated water or with Castile soap, followed by an application of hydrogen peroxide.

Thus far no widespread disease among foxes has made its appearance. When diseases occur they mainly affect the digestive organs, and usually can be traced to improper feeding. Indigestion and inflammation of the bowels are not uncommon among cubs. Isolation in clean, dry quarters is the first step toward a cure, and rest and fasting are better than medicine. A spoonful of milk diluted with six spoonfuls of boiled water will quench thirst and aid in maintaining strength. The feces should be examined daily. Constipation is frequent, and it is especially dangerous to vixens during the first three days after the birth of their cubs. It can generally be corrected by a laxative diet, as milk, liver, or veal, but in extreme cases a dose of castor oil or an injection of soapsuds may be necessary. A protracted attack of diarrhea can usually be checked by a purge of castor oil followed by small doses of laudanum. Generally, however, a day or two of fasting followed by short rations of cooked milk or milk and eggs, at intervals of two or three hours, will effect a cure. During such an attack vitality runs low, and care must be taken to keep the afflicted animal in a warm, dry place. It should have access to water that has been boiled. Growing cubs are frequently subject to weakened and distorted legs. This disease, known as rickets, can be prevented by including ground bone in their meat rations and by adding limewater to their milk. The bones of calves and those from the briskets of beeves are comparatively easy to crush so that foxes can swallow them.

At quarantine stations where imported animals are examined, particular attention is directed to symptoms of rabies and mange. The fact that rabies, or hydrophobia, is communicable to man makes it doubly dreaded. Fortunately it has not appeared among domesticated foxes so far as known. Mange is characterized by a loss of fur. It is caused by a tiny parasite, somewhat like the itch mite, and is, therefore, very contagious. Were it to obtain a foothold among domesticated foxes, it would seriously hamper and perhaps ruin this branch of the fur industry. All animals showing a tendency to have bare spots should be isolated at once. The diseased parts should be treated daily with ointments, as petrolatum or a mixture of lard and sulphur.

Foxes serve as hosts for a number of other parasites. Lice and fleas infest their hair and skin, while roundworms and tapeworms drain their vitality from within. The death of a fox has occasionally been attributed to lice. Even if not fatal, lice and fleas diminish the vigor of their hosts and should be persistently combated. Some fox breeders dip all their animals in a nonpoisonous bath such as is commonly used for dipping sheep. It is well in any case to dust the dens with sulphur and insect powder at frequent intervals.

The intestinal worms infesting foxes are difficult to eradicate. Probably more young foxes succumb to the effects of roundworms than to any other cause. These worms are whitish and cylindrical, tapering toward either extremity. Among the symptoms indicating their presence are dullness, barking, frothing at the mouth, dragging the body by the forelegs, and convulsions. The flat, jointed tapeworm, often a foot or more in length, is a less fatal as well as a less common internal parasite, but animals suffering from them are emaciated and lack overfur or guard hairs. As a cure for worms one breeder of long experience frequently gives his cubs a meal of crushed flaxseed and milk, alternating now and then with six or eight drops of spirits of turpentine in milk. Another doses his cubs every fortnight after they are four weeks old with a proprietary vermifuge put up in gelatine capsules for puppies and pet dogs, beginning with half the contents of one capsule. Castor oil containing a few drops of turpentine is also recommended. Any remedy administered by hand must be pushed down below the base of the tongue, when it will be involuntarily swallowed.

A fox sometimes dies from no assignable cause. More often fatalities can be traced to a lack of care or foresight. The dishes from which the animals eat and drink should be washed daily and scalded frequently. The water should be clean and changed daily. The food should be varied and wholesome. Danger from unwholesome food is well illustrated in the experience of one ranchman who lost several of his choice breeders through feeding them spoiled fish; and another who lost \$100,000 worth of cubs as a result of thoughtlessly exposing meat overnight to the fumes of gasoline in his slaughterhouse. The appearance of each animal should be critically noted every day. On many of the larger ranches a doctor is regularly employed to look after the health of the stock. In the care of foxes an ounce of prevention is worth a pound of cure.

#### IMPROVED STRAINS.

The fact that domestic animals originated from wild stock and that improved strains have from time to time been secured makes it reasonable to assume that other wild animals can be differentiated and improved by the same method, namely, selective breeding. So far as foxes are concerned, this has already been done. The pioneer fox breeders began with ordinary silvers, which have a tendency to produce red as well as silver progeny. At that time dark pelts were more valuable than light-colored ones. By regularly disposing of the less desirable cubs and breeding only from the best, the tendency to throw red was soon eliminated and the color of the fur greatly improved. Within 16 years from the time the two pioneer fox

breeders built their ranch they were sending to market the finest fox pelts in the world.

The tendency of wild silvers to produce red progeny is accounted for by the fact that owing to their scarcity probably only one in a hundred can have a silver mate; perhaps three in a hundred may mate with cross foxes, which are merely hybrids, or descendants from hybrids, between silvers and reds; and the remaining ninety-six must mate with reds. In any event, although some of the cubs may be silver, all of them will inherit from their red ancestors a tendency to throw red. As has already been pointed out, however, this tendency very soon disappears under the influence of careful breeding. Generally speaking, pure strains of silver foxes breed true. So also do pure strains of red. When a red and silver are mated together, the color of the progeny can not be foretold. The cubs may be red with black throats, or they may be crosses, or a mixture of the two. One or more may be silver, but this is unusual. Random breeding from silvers and crosses of unknown pedigree is equally uncertain, as is shown by the following results:

A silver mated with a red produced two crosses, which when mated together produced one red and four silvers. A silver and a cross produced three silvers and two reds. A cross and a red produced two crosses and two reds. A cross and a cross produced two silvers, two crosses, and one red. Another pair of crosses produced nine crosses. A red of silver-cross parentage mated with a red of silver parentage produced one silver and two crosses. A silver and a red produced in two successive years thirteen silvers. A pair of reds from the same litter as two silvers produced three silvers, one cross, and two reds. A pair of silvers produced one silver and five reds, two of which, when mated together, produced three silvers and one red the first year and two silvers the next year. Another pair of silvers produced four crosses, while a silver and a cross produced a litter of all silvers.

These results indicate the uncertainty of breeding at random, but they show also that if a fox of any color whatever has a silver strain, the silver can be made to appear in succeeding generations by selective breeding. This fact is most important. Suppose a breeder has a strain of silvers lacking in size, or fecundity, or in some other desirable particular. He can introduce specimens having the desired qualities without having to consider color. A red fox can be used if one of better color is not available. In the course of three or four generations the silver can be fully reinstated. Among the features to be considered besides color are size, fineness of fur, fecundity, docility, and hardiness. Fecundity appears to be a hereditary trait among foxes, daughters of prolific mothers being themselves generally prolific. How rapidly other desirable characters can be in-



corporated remains to be determined. As with poultry, horses, and other farm animals, so it is with foxes. Each breeder should strive to perfect his animals according to some standard. Eventually there may be several standards based upon varied uses or requirements.

The process of developing improved strains can undoubtedly be shortened by taking advantage of local variations in foxes. One of the lines of investigation conducted by the Biological Survey includes the geographic variations of North American mammals, and from this it is possible to say not only where silvers and crosses occur most frequently, but where the largest and the best-furred foxes are found. Upward of 20 species or subspecies of red foxes have been named in the United States and Canada. The medium-sized foxes along the North Atlantic coast are notable for their fine silky hair. The largest foxes are in Alaska and on the Plains northward from Minnesota and North Dakota. The large size of Alaskan coast foxes is offset by long, coarse pelage, which is decidedly longer on the shoulders and back of the neck than on the back and hips. It remains to be seen whether in crossing them with the smaller, finer-haired animals the progeny will be large or small, coarse-haired or fine, or intermediates. There can be little doubt, however, that in the long run such a cross will result in larger fine-haired foxes than any now existing. The northern part of the red fox's range has, as a rule, a larger proportion of silvers than has the southern. An exception is found in the Cascade Mountains in Washington, Oregon, and California, where, judging from specimens in the National Museum, the percentage of melanistic specimens is very large. They have little to recommend them besides color, however, as they are small and have rather coarse fur.

Black and silver foxes are found in North America practically throughout the range of the red fox. The best-furred animals do not occur, however, throughout this range, but are obtained mainly in restricted areas. For instance, skins from the Tanana River district in Alaska and the adjacent part of Yukon Territory, from certain other parts of northern Canada, and from the North Atlantic coast from Maine to Labrador, including Prince Edward and other islands, are of about the same grade. This is recognized by the leading London furriers, who report that "in our opinion fox skins from Labrador, Newfoundland, or Alaska are equal in quality to those from Prince Edward Island."

It is not known that any particular geographic race of foxes is especially characterized by fecundity or docility. These qualities are probably individual, occurring in about the same proportion everywhere, and while of secondary importance, in the long run they are sure to be favorable to success in fox farming. Already prolific pairs bring much higher prices than those which have thrown

small litters or have not been tested. Inasmuch as one of the main causes of loss among young cubs is the timidity and nervousness of vixens, the development of more docile strains will result in corresponding increase in the birth rate. Some male foxes are much better mates and sires than others. In selecting breeders the temperament of males as well as of vixens should be considered. The physical development and potency of males are also essential factors. Young males that are not strong or not well developed when six months old are not likely to be of use in the breeding yards the first year and should not be selected for sires.

Food is recognized as a very important element in the development of good animals. The finest specimens of domestic cattle are those which have been fed most wisely. As regards foxes, much remains to be learned concerning the effects of different rations upon such matters as fecundity, character of fur, and rate and limits of growth. It should be a part of every breeder's plan to discover all he can about the relative values of foods and methods of handling, as influencing the process of selective breeding. Ultimate success or failure in fox farming depends largely upon the aspirations of those engaged in it. If breeders earnestly, consistently, and indefatigably endeavor to improve their stock and to produce pelts that are larger, softer, and more uniformly colored than the usual run, there can be no question as to the result. There will never come a time when an extra fine silver fox pelt will not command a good price nor when a breed producing such pelts will not be in demand.

#### ACCESSORIES.

Contentment and vigor of the animals within a ranch is of the utmost importance. Whatever contributes toward increasing these qualities should be incorporated if possible. It is well to test young foxes with such toys as a ball, a tin can, or a piece of woolen cloth, with a view to amusing them and exciting a spirit of playfulness. A variety of objects in which they can hide and upon which they can mount for a survey of their surroundings, as hollow logs, stumps, brush piles, or open barrels, is desirable.

While the suggestions given under this heading apply primarily to persons having large capital invested in fox farming, they will also be found helpful to those operating on a small scale. The present value of silver foxes is so great that every precaution is taken to prevent accidents, sickness, or other misfortunes. Watchmen are kept on guard day and night. The keeper's lodge is just outside the guard fence. In addition there is sometimes a tower, from the top of which a view can be had of all the yards. Here are recorded the progress of events in the breeding season; and from here quarrels, accidents, or signs of sickness can be discovered without alarming the animals.

A tower 12 or 15 feet square and three stories high, fitted up as a 3-room house, would contain on the top floor the watchman's couch, chair, and field glasses, his table and writing materials; a cook stove, pantry, sink, and other kitchen appurtenances will be on the ground floor, and here food for the foxes can be conveniently prepared. Somewhere about the place there will be a medicine chest and various tools likely to be needed in an emergency.

Risk of loss by theft or escape is lessened by installing electric lights which can be turned on at any time, and an electric burglar alarm. Bulldogs are used to reenforce the night watchman; and on some ranches bloodhounds are kept for tracking thieves. Foxes that escape generally return to the vicinity of the ranch when hungry, and a number of small steel traps having the jaws wound with cloth should be kept on hand to catch them. Ranch foxes have less endurance than wild ones, and a good hound can usually overtake one after a short run. The manager of a ranch on Prince Edward Island has a hound which on several occasions has assisted in the capture of foxes without hurting them in the least. Such dogs are excellent insurance against loss by escape.

Other accessories of a fox ranch, and those most prominent, pertain to food supplies. There must be facilities for slaughtering horses, cattle, and smaller animals; an ice house and a refrigerator for keeping the meat fresh until it can be used; and conveniences for drying, smoking, and salting meat that must be kept a long time. A screened room or box is necessary to protect stored meat from flies. Cows are needed to furnish milk, an important element in the diet of domestic foxes. In a dairy region calves are disposed of when but 2 or 3 days old. At that age they are small, and their flesh is soft. Sometimes there are more calves on hand than can be used immediately. By having cows to suckle them a few weeks, the veal, improved in quality and increased in quantity, will be available when needed. Rabbits are the natural prey of wild foxes. They have an important place on a fox ranch as a fox food which can be drawn upon at any time, which is always fresh, and which is in such small units that ice or other preservatives are unnecessary.

Occasionally a vixen having young cubs is unable to give them proper attention. Then a foster parent must be supplied at once or the cubs will die. To provide for emergencies of this kind, every ranch should include several female cats.

#### MARKETING.

The products of a fox farm—breeding stock and pelts—are ready for market at definite seasons. The live animals are mainly sold during the autumn, as it is to the interest of buyers to have their stock fully accustomed to new surroundings before the breeding sea-

son. By the middle of September, young foxes are large enough and the weather is sufficiently cool for shipping with safety. When there is not an adequate local demand, foxes are generally disposed of by advertising in publications devoted to furs, fur farming, or trapping. Shipments of live stock by express are generally at the risk and expense of the purchaser. Valuable animals are usually accompanied by a caretaker, especially if the journey lasts more than two days.

Skins of foxes killed late in December, when fox fur is in its finest condition, are ready for market in January. Foxes are skinned by making a cut straight from one heel along the rear edges of the hind legs and beneath the tail to the other heel, and withdrawing the body through this slit. The skin of the tail should be cut along the lower side, its entire length, and the bone removed in order that air may come freely into contact with the flesh side and dry it quickly. Unless this precaution is taken, the tip of the tail is likely to decompose and lose its hair. For the same reason the back skin of the ears should be separated from the cartilage to which it is attached. When the operation of skinning is over, the pelt is freed from particles of fat and muscle. It is then drawn, flesh side out, over a stretching board similar to the one shown in figure 22, not

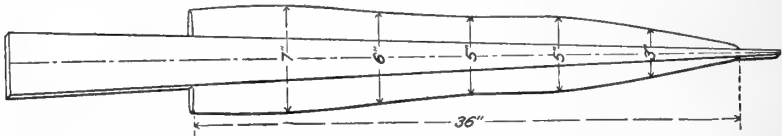

FIG. 22.—Diagram for stretching board for casing skins. The wedge makes it adjustable in width and facilitates removal from a skin.

for the purpose of actually stretching the skin but to prevent it from shrinking and becoming wrinkled as it hardens. Before the skin is completely dry it should be removed from the board, turned hair side out, and hung by the nose where it will be free from pressure on all sides. No preservative is required. Although raw fur buyers are to be found in nearly every town in fur-producing regions, fox farmers prefer to sell their peltries direct to metropolitan establishments, where rare furs are handled extensively and where experienced furriers are familiar with values.

In preparing valuable peltries for market, extreme care should be taken to prevent blood from coming in contact with the fur. With this in view, the method of killing commonly adopted is to lay the fox on its side on clean snow, and then to compress its chest by standing upon it. This stops the action of the heart and lungs and death follows immediately. The same result, without the unpleasant features connected with thus catching and smothering the animal, can be obtained by means of a killing box, which from a humanitarian point of view is preferable. This is merely a tight wooden

box into which the fox is to be driven from its den. When the fox is inside and the door securely closed, an ounce or two of chloroform or carbon bisulphide is poured through a hole in one of the upper corners into a wide, shallow dish, as a tin pie plate, fixed just below in such manner that the fox can neither get into it nor upset it. The hole through which the pouring is done should be corked at once and every part of the box made practically air-tight. The smaller and tighter the compartment the less will be the quantity of anesthetic required. The box should not be opened within half an hour.

In localities where fox farming is carried on extensively, it will be found advantageous for producers to establish a selling agency in charge of one familiar with the fur trade. In this way it will be possible to match many of the skins and sell them in sets at a higher price than can be obtained for odd skins.

### COSTS.

The cost of establishing a fox ranch varies according to the materials used, transportation facilities, and the proportion of labor performed by the owner. The factory price of the netting described in the section relating to inclosures is from 1 to 3 cents a square foot, according to the mesh and size of wire, when sold in rolls containing 150 linear feet. It is manufactured in the various widths required for different parts of the fences. Ordinarily in a fur country the expense for lumber would not be great. A considerable saving can sometimes be made by building the guard fence of boards instead of netting. The average life of the netting is about 12 years, except when exposed to sea air, in which case it is only about 8 or 10 years.

Feeding a fox costs from \$5 to \$15 a year. On a farm where there are cows and where grain and vegetables can be raised, it is not necessary to buy very much fox food. Except on large ranches devoted exclusively to fox raising and where a special keeper must be employed, the care of a few foxes will not entail much outlay.

The fixed annual charges against a pair of silver foxes will vary with the locality, value of equipment, etc. On some ranches it has been estimated about as follows: Interest on cost of yards, \$10; depreciation of yards, \$10; food, \$20; and attendance, \$50; amounting to \$90; added to this must be a reasonable charge for interest on the original cost of the pair. Killing foxes at the age of 4 or 5 years, when their pelts are good, and breeding always from young stock may be practicable, but this point has not yet been decided. As a rule, one may expect to keep choice animals as long as they are productive; that is, about 10 years. Deterioration, therefore, on the live stock will be 10 per cent; and to this should be added 10 per cent for insurance against loss by death, escape, or theft.

The value of breeding stock has fluctuated greatly in the past. In general, it will depend on the current demand for silver fox skins; and, in particular, on the character of the fur of individual animals. Prolific animals belonging to choice strains, in which a superior color and quality of fur have been fixed, are worth for breeding purposes as much more than ordinary stock as pure-bred horses are than common horses.

As has been pointed out under the subject of improved strains, crosses and reds derived from silvers throw a proportion of silver cubs. It is feasible, therefore, if one is willing to sacrifice the time required, to obtain a stock of silvers from these more common foxes, which cost comparatively little.

#### INCOME.

The profits from silver fox farming have generally been large. Prior to 1910 they were derived almost wholly from pelts, but since then they have come mainly from the sale of breeding stock. Following the decline of the speculative phase of the fox industry, ranch-raised silver fox pelts reappeared at fur sales, and brought encouraging prices, a few going as high as \$1,000 each. January quotations for first-grade skins during the 12 years from 1905 to 1916 average about \$600 each. Out of a miscellaneous collection of silver fox skins, principally wild, disposed of at auction early in 1916, 60 were sold at an average of \$550. Many wild skins are necessarily imperfect, being unprime, worn, or not well colored, but those from selected domestic animals killed when their fur is at its best may be confidently expected to rank as first-class goods.

The supply of silver fox pelts must always come from cold climates beyond the more thickly settled temperate regions. They are not likely, therefore, to become overabundant. Red fox skins have been marketed for many years. Their numbers, while fluctuating considerably from year to year, on the whole have remained approximately constant. Their average value, however, has increased. But the supply from wild foxes can never be greater than it is now. Already red foxes can be raised and their pelts sold without loss, and it may be probable that before many years the rise in fur values and the introduction of more economical methods of ranching will result in making the raising of red foxes profitable. The silvers are of superior beauty and many years must pass before they can become common.

ERNST MAYR LIBRARY



3 2044 110 361 789



