



3 1761 05481007 2



Digitized by the Internet Archive
in 2007 with funding from
Microsoft Corporation

UNIVERSITY OF TORONTO
DEPARTMENT OF CIVIL ENGINEERING
PROPERTY OF
TORONTO BRANCH
ENGINEERING INSTITUTE
OF CANADA
UNIVERSITY OF TORONTO
DEPARTMENT OF CIVIL ENGINEERING
Municipal and Structural

No. _____

UNIVERSITY OF TORONTO
DEPARTMENT OF CIVIL ENGINEERING
Municipal and Structural

DREDGES AND DREDGING

BY

CHARLES PRELINI

*Author of "Earth and Rock Excavation," "A Treatise on Tunneling," "Earth Slopes,
Retaining Walls and Dams," Professor of Civil Engineering in
Manhattan College, New York*

82 ILLUSTRATIONS

SECOND EDITION

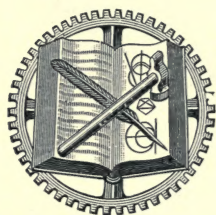

NEW YORK
D. VAN NOSTRAND COMPANY
25 PARK PLACE
1912

UNIVERSITY OF TORONTO
DEPARTMENT OF CIVIL ENGINEERING

Copyright, 1911,
BY
D. VAN NOSTRAND COMPANY



THE SCIENTIFIC PRESS
ROBERT DRUMMOND AND COMPANY
BROOKLYN, N. Y.

PREFACE

It is an old and true saying that "of making many books there is no end," and this is especially true in regard to engineering treatises, as each decade brings its improvements, and practices that are in vogue one year are almost obsolete within a few years. To-day, too, there is a great demand in the profession for books on practical subjects, as it is only in this manner that the young man is able to profit from the experience of his older brother.

It is a singular fact that nearly every man feels that he is competent to carry on a job of earth or rock excavation, yet there is nothing more difficult than to do such work economically. Man since prehistoric times has been digging into mother earth, yet there is always something to learn regarding excavation work. The last word will never be said on the subject. In this treatise only one class of excavation is touched upon, namely, dredging.

If one needs an excuse for offering to the profession this book, it is found in the vast importance of dredging in our commercial life. Not only are there millions upon millions of dollars invested in dredging plants and outfits, but it has only been possible to construct and use vessels of great tonnage, owing to the wonderful achievements of the dredge designers and the engineers and contractors engaged in operating such machines.

Then, too, great canals are constructed with the aid of dredges, large areas of swamp lands are reclaimed for the use of man with such machines, and precious metals are recovered from streams or river bottoms with their aid.

This treatise is written with a view of presenting the subject in a concise and logical manner, so that it may be found useful both to the man of experience and to the beginner or student. Should it so prove the author will feel that his labor has not been in vain.

The thanks of the author are due Mr. Daniel J. Hauer for many valuable suggestions.

C. P.

Manhattan College, September, 1911.

CONTENTS

	PAGE
LIST OF ILLUSTRATIONS.....	ix
INTRODUCTION. A HISTORY OF DREDGES AND DREDGING.....	xi
CHAPTER I	
DREDGING AND DREDGES.....	1
CHAPTER II	
SOILS AND THEIR CHARACTERISTICS.....	6
CHAPTER III	
SOUNDINGS AND HYDRAULIC SURVEYS.....	12
CHAPTER IV	
EXCAVATION OF SUBAQUEOUS ROCKS. GENERAL DISCUSSION. EXCAVATION BY HAMMERING.....	21
CHAPTER V	
EXCAVATION OF SUBAQUEOUS ROCKS— <i>Continued</i> . BY BLASTING. COMPARISON OF THE TWO METHODS.....	29
CHAPTER VI	
EXCAVATION OF SUBAQUEOUS ROCKS— <i>Continued</i> . BY A LARGE BLAST....	42
CHAPTER VII	
HINTS ON SELECTING DREDGES FOR VARIOUS WORK.....	50
CHAPTER VIII	
DREDGING CREWS, THEIR QUARTERS, AND TENDERS FOR DREDGES.....	56
CHAPTER IX	
CLASSIFICATION AND CAPACITIES OF DREDGES.....	60

	PAGE
CHAPTER X	
LADDER OR ELEVATOR DREDGE. GENERAL DISCUSSION.....	68
CHAPTER XI	
SEA-GOING LADDER DREDGES.....	74
CHAPTER XII	
SEMI-SEA-GOING STATIONARY AND HIGH-TOWER LADDER DREDGES.....	83
CHAPTER XIII	
HYDRAULIC DREDGES. GENERAL DISCUSSION.....	94
CHAPTER XIV	
SEA-GOING HYDRAULIC DREDGES.....	105
CHAPTER XV	
HYDRAULIC DREDGES FOR CHANNELS AND RIVER IMPROVEMENTS.....	120
CHAPTER XVI	
UNIVERSAL DREDGES.....	132
CHAPTER XVII	
STIRRING DREDGES.....	140
CHAPTER XVIII	
PNEUMATIC DREDGES.....	147
CHAPTER XIX	
DIPPER DREDGES. GENERAL DISCUSSION.....	151
CHAPTER XX	
DIPPER DREDGES— <i>Continued</i>	161
CHAPTER XXI	
GRAB DREDGES.....	168
CHAPTER XXII	
DESCRIPTION OF CLAMSHELL DREDGES.....	178

CONTENTS

vii

CHAPTER XXIII

	PAGE
TRANSPORTATION OF THE DEBRIS. CONVEYORS, BARGES, ELEVATORS.....	185

CHAPTER XXIV

METHODS AND COSTS OF RIVER DREDGES.....	204
---	-----

CHAPTER XXV

DREDGING FOR METALS.....	217
--------------------------	-----

CHAPTER XXVI

DREDGING FOR INDUSTRIAL PURPOSES.....	233
---------------------------------------	-----

CHAPTER XXVII

DRY-LAND DREDGING.....	245
------------------------	-----

CHAPTER XXVIII

THE COST OF OPERATING DREDGES.....	253
------------------------------------	-----

CHAPTER XXIX

COST DATA.....	260
----------------	-----

LIST OF ILLUSTRATIONS

FIG.

- 1, 2. Methods of Laying out Triangulation Points.
3. Scott & Godsir Rockcutter.
4. Lobnitz Rockcutter.
5. Saunder's Machine for Subaqueous Rock Excavation.
6. Drilling Platform Used on the Danube River.
7. Ingersoll Drilling Scow.
8. Rand Drilling Boat.
9. Boat with Submerged Caisson for the Excavation of Rock under the Rhine River.
10. Plan of Flood at Hell Gate, N. Y.
11. Honeycombing of Flood Rock showing the Direction of Drill Holes in Galleries.
12. Plan of the Ledge of Rock at Henderson's Point.
13. Method of Excavation Followed at Henderson's Point.
14. Stone Lifter on St. Lawrence River.
- 15, 16. Side View and Part of the Deck Plan of the Dredge "Ville de Rochefort."
17. Dredge "Pas-de-Calais."
18. Dredge "Cadiz."
19. Dredge for the Marne Canal.
20. Dredge for the Rhone River Propelled by Sprocket Wheel.
21. Stationary Ladder Dredge.
22. Stationary Ladder Dredge on the Fox River, Wis.
23. Dredging Plant Used on the Fox River, Wis.
24. High Tower Ladder Dredge "City of Paris."
25. Allen Scraper Used on the U. S. Dredge "Manhattan."
26. Rotary Cutter at the End of Suction Pipe.
- 27, 28. Cross-section and Side View of the Centrifugal Pump of a Hydraulic Dredge.
29. Hoppers in the Hydraulic Dredge "Nereus."
30. Sand Pump on Dredge "Nereus."
31. Dredge "Thomas."
32. Cross-section of the Dredge "Thomas," showing Central Pit and Lateral Hoppers.
33. Central Portion of the Dredge "City of Rouen," showing the Single Hopper Amidships.
34. Dredge "J. Israel Tarte."
35. Plan and Longitudinal Section of the Dredge "J. Israel Tarte."
36. Floating Discharge of the Dredge "J. Israel Tarte."

FIG.

38. Cross-section of the Dredge "King Edward VII."
37. Deck Plan and Longitudinal Section of the Dredge "King Edward VII."
39. Dredge "King Edward VII."
40. Dredge "St. Petersburg."
41. Longitudinal Section of the Dredge "Montevideo."
42. Jandin Method for Sinking Tubular Piers.
43. Plan and Elevation of Steel Trusses Reinforcing the Hull of the Dredge "Chicago."
44. Side and End Views and Deck Plan of a Small Dipper Dredge with Bank Spuds.
45. Dipper Dredge of Six Cubic Yards Capacity.
46. The Dipper Dredge "Independent."
47. Dipper Dredge "Majestic."
48. English Grab Bucket Dredge.
49. South American Grab Dredge.
50. Grab Bucket for Dredging Through Clay.
51. Grab Buckets for Gravel and Boulders.
52. Orange Peel Bucket, Open.
53. Orange Peel Bucket, Closed.
54. Cooper & Holdsworth's Single Chain Attachment.
55. Dredge "Finn MacCool."
56. Ten Cubic Yard Clamshell Bucket of the Dredge "Finn MacCool."
57. Sectional View of the Clamshell Bucket "Arnold."
58. Dredge "Champion."
59. Ladder Dredge with Pipe Conveyor.
60. Pipe Line Conveyor of the Dredge "J. Israel Tarte."
61. Open Hold Barge.
62. Dumping Scows Used at Suez.
63. Dumping Scows for Shallow Water.
64. Sea-Going Steam Hopper.
65. Dumping Scow with Sliding Platform.
66. Sidewheel Tugboat.
67. Screw-Propelled Tug Boat.
68. Bucket Elevator for Unloading Barges.
69. Floating Elevator for Unloading Barges.
70. Floating Elevator with Double Ladder.
71. Grab Bucket for Unloading Barges.
72. A Placer Dredge with Revolving Screen.
73. Placer Dredge with Shaking Screens.
74. Placer Dredge with Sluice Box.
75. Plan and Elevation of a Long Sluice-Box.
76. Placer Dredge.
77. Hydraulic Sand Dredge.
78. Ladder Sand Dredge.
79. Machine for Unloading Sand from Barges.
80. Title Lands at Seattle.
81. Bucket for Dry Land Dredging.
82. The Austin Drainage Excavator.

INTRODUCTION

THE HISTORY OF DREDGES AND DREDGING

DREDGING is an old industry, but it is only within the last fifty years in Europe, and during the past twenty-five years in America that rapid advances have been made in designs and types of machines, so that the cost of dredging has been materially reduced. It is almost impossible to give an accurate history of the industry of dredging, but a few facts can be given that may be of interest to the student.

No doubt the ancients used some primitive forms of dredges, but if any such work was done by them it was generally near the shore and was in most cases done by hand. The boats used by the ancients were built to go in shallow water, so that there was not much need for dredges. It may be of interest to note that even to-day some dredging is done by hand. (See report of the Minister of Public Works of Canada for year ending June 30, 1903.)

The first forms of dredges were long-handled scoops operated by hand from floating platforms. Then a windlass or drum was used to aid in the work, and then scows were substituted for the platforms or rafts. The development was no doubt gradual, although it is a great step from these primitive scoops to the immense buckets and dippers of to-day.

In operating the early scoop dredges it was found that the work done stirred up much material which floated away when there was a strong current. This brought into use methods of stirring.

The first mention of a rude dredging machine is by a writer named Veranteus in the year 1591. The first power dredge was one invented by a Dutch engineer, one Cornelius Meyer, in 1685. It was operated by horse power, and was used in constructing some of the canals and dykes of Holland.

On the continent of Europe the first elevator or ladder dredge was designed and patented by Savery in 1718. The first dredge of this type in England in 1747. Three years later in France iron buckets were first used on a ladder dredge. In 1781 a ladder dredge was built in England and operated by horse power.

The first steam dredge was built in England in the year 1796, the engine being designed by the inventor James Watt. This was followed in 1804 by a machine of the same design, only heavier.

Little progress was made in dredge designs and building during the first half of the 19th century. During this time there was built in England a dredge of rather unusual design. A barge or scow had two movable wings at the stern that reached if desired to the two banks and to the bottom of the stream. At the back was a scraper that loosened the dirt, and the two wings, with the aid of the current, swept the loosened material ahead and finally deposited it at the mouth of the stream. The wings formed a temporary dam, which gave enough head to force the scow downstream. Some noteworthy work was done with such dredges.

The first hydraulic or suction dredge was suggested in France in 1867, which was really the beginning of the construction of modern dredges. In 1872 the first dredge of this type was built in America. Cutters were first placed on hydraulic dredges in 1878. The credit of building the first hopper dredge in 1861 is given to England.

The dipper type of dredge was not originated in America, but it has been developed in the United States and is considered distinctly an American dredge.

In the last few decades wonderful strides in these machines have been made. From small buckets operating slowly, buckets of more than 10 cu.yds. are used with a pull of about 100,000 lbs. being exerted on the dipper, and three or four dips made per minute. Likewise the depth to which they will excavate has been greatly increased.

The grapple dredge has been an evolution of the dipper machine, and as its distinguishing feature is the clamshell or orange-peel bucket, it is evident that it is a modern machine.

Since 1890 both in Europe and America wonderful advances have been made in all types of dredges. One country has introduced a design while another has developed it and improved upon it.

This has been so regarding the ladder dredge for mining purposes. In the sixties much experimental dredging for gold was

carried on in New Zealand, with the result that the ladder dredge was accepted as the best type for the purpose. Within a short time the ladder dredge was introduced in Western United States for gold mining, and to-day the dredges used in California are said to excel all others in use for gold mining throughout the world. It has only been within twelve years that the tailing stacker has been used in connection with these dredges. This device has greatly simplified the work and materially reduced the labor needed to operate the machine.



A TREATISE ON DREDGES AND DREDGING

CHAPTER I

DREDGING AND DREDGES

DREDGING is the operation of excavating soils from the bottom of bodies of water. It is undertaken for different purposes, chiefly for deepening and widening the bed of rivers and navigable channels, or for deepening harbors and bays to facilitate navigation, or preparing the foundations of immense masonry structures, which should be located directly on ledge rock, usually encountered far below the bed of the stream. To-day dredging is also undertaken for mining and other industrial purposes, as will be shown later. No matter for what reason these dredging operations are undertaken, they are always made by powerful machines called Dredges in America and Dredgers in England, built with an efficiency proportionate to the magnitude of the improvement upon which they are employed.

Engineers and public officials frequently do not realize the importance of dredging. Vast sums of money are being spent for this class of work and new projects are continually being placed before the public that involves dredging. Even manufacturers of dredging machinery do not seem to comprehend the future great development of this industry, as dredges are the means of handling large quantities of raw materials as well as of making extensive excavations both on land and under water.

The principal uses of dredging machinery may be grouped as follows:

Channels:

Deepening and widening channels through bays and rivers.

Harbors:

Cleaning out harbors.

Building new harbors.

Enlarging old harbors.

Rivers:

Straightening rivers.

Removing obstructions, as sandbars, deposits of mud, sawdust, etc.

Building dykes and levees.

Canals and ditches:

Navigation.

Drainage.

Irrigation.

Power.

Reservoirs and dams:

Cleaning out débris and deposits of vegetable matter.

Reclaiming:

Low ground.

Filling behind bulkheads and piers.

Flooding land to dredge it.

Mining:

Gold from rivers.

Gold from placer deposits.

Platinum.

Tin.

Marl for cement industry.

Clay for bricks and pottery.

Phosphate rock for fertilizer.

Sand:

For building purposes.

For glass industry.

Magnetic sand.

Gravel:

For many purposes.

Foundation work.

Dredging usually involves other operations, which are: The hydraulic survey of the locality to be improved, the knowledge of the quality and quantity of the soil to be excavated, and finally the work of the machines used in the excavation of the materials from the bottom and of those employed in the transportation of the débris.

The hydraulic survey is easily obtained by any one of the well-known methods. From this survey a chart may be made indicating the depth of the various points along the line of the proposed improvement. Knowing the depth of each point as required by the improvement, while from the survey is learned its present depth, it is evident that their difference will represent the height of the excavation at such a point. The total difference of all the points will give the total amount of material to be excavated in order to obtain the required improvement.

The soils, considered from the point of view of the cohesive force of their particles, may be broadly divided into rocks and loose soils. Rocks are those in which the force of cohesion is so great that great power is necessary in order to separate its particles. Loose soils are those having the particles united by such slight cohesion that it can be easily overcome.

In dredging, different kinds of machines are used, depending upon the quality of soils. Solid rock must first be reduced to small fragments, so as to be readily raised to the surface. The rock is usually broken in two different ways, by hammering and by blasting. The hammering consists in attacking the rock by means of successive blows struck, with great violence, while in blasting the rock is shattered by the mighty force of dynamite or other explosive. It is in the excavation of loose soils as well as for picking up the fragments of rock broken by any one of the methods to be indicated, that the dredging machines are employed. These are divided into continuous and intermittent types. Continuous are those that remove continuously the material from the bottom, while intermittent are those that engage the material at intervals.

Dredges. Continuous dredges are of four different types—the ladder, the hydraulic, the stirring, and the pneumatic dredges. The ladder dredge excavates the bottom by means of a series of buckets running with great velocity along a ladder. The buckets scrape the soil at the bottom, raise the débris to the surface and

discharge it into barges or conveyors so as to send it to its final destination. The hydraulic dredge removes the material from the bottom by means of a large centrifugal pump which draws the materials, mixed with water, into a suction tube and forces them to distant points by means of a long line of pipes. The stirring dredges are those employed in the excavation of soils composed of very finely divided particles; they agitate the soil and the material thus brought in suspension is carried away by the action or current of water. The pneumatic dredges are those in which the material from the bottom is forced into the suction tube and thence into the discharging pipe, by the action of continuous jets of compressed air turned upward into the tube.

Intermittent dredges are those provided with a single bucket of large capacity, by means of which the material at the bottom is raised to the surface and dumped into scows, to be conveyed to distant points. All these various operations are made by the bucket before it returns to the bottom to once more engage the material. The single-bucket intermittent dredges are of two different types, the dipper and the grapple dredges. The dipper dredge is similar to the steam shovel used in land work, the only difference being that it is mounted on a float, and the bucket is usually of larger capacity. The grapple dredge is provided with buckets in the shape of the clamshell or of the orange-peel, thus originating two principal varieties of the grapple dredge, known as the clamshell and the orange-peel bucket dredges; These machines are also mounted on floats and the capacity of the buckets is large.

Transporting Excavated Materials. The materials raised from the bottom of the water are transported to their final dumping place by various methods. In the sea-going hopper dredges the materials are stored in large bunkers and are carried to the dumping place on board of the same steamer carrying the excavating machinery. The *débris* can also be conveyed by means of belt conveyors or pipes, or transported on floats and barges with closed bottoms from which the materials are raised again by some device and sent to their destination, or the scows are self-dumping, discharging the *débris* into the deep water by simply opening the gates forming the floor of the scows.

A thorough knowledge of the various soils and machines is necessary for successful dredging; and this depends exclusively upon the fact that the best-suited machine should be used for the

removal of a certain kind of soil. In dredging, the greatest attention should be given by engineers and contractors to the selection of the machines, which should be the most efficient and economical for the improvement under consideration. Such a selection, however, should be the result of a thorough knowledge of both the various excavating and transporting machines at their disposal, and the kind of soil to be removed.

CHAPTER II

SOILS AND THEIR CHARACTERISTICS

IN considering any harbor or river improvement necessitating the employment of dredges, as previously shown, it is important to carefully examine the nature of the soil to be excavated. Such a study will influence the selection of the machines and the arrangement of the work. By using the most efficient machines and arranging the work in the most convenient way the improvement under consideration will be done in the most economical manner, namely at the smallest cost. Hence the great importance of a thorough knowledge of the soil to be excavated.

It would be impossible to describe all the various soils that may be encountered in dredging. They are found in so many varieties and so mixed together that it is difficult to trace each to its respective group. However, for sake of classification only the most characteristic soils will be reviewed here, indicating the type of dredge considered the most appropriate for working in each soil. The soils will be reviewed in the following order: Rock, disintegrated rock and conglomerates, gravel, hardpan, clay and loam, sand and silt.

Rock. The ordinary dredging operations usually consist of clearing the bottom of canals, rivers, bays, harbors, etc. Since these basins are formed by alluvial deposits accumulated there for centuries, as a rule, they form strata of great thickness, and solid rock is very seldom encountered. But even in the few cases in which rock is found, owing to the fact that for a long time it has been exposed to the destructive action of fresh or salty water, it is generally found in such a disintegrated condition, as to be considered a loose soil instead of real rock. However, in removing obstructions to navigation or in widening and deepening harbors and channels, solid ledges of rock are encountered. It is removed, as stated, either by hammering or blasting.

Disintegrated Rock and Conglomerates. The rock that has been disintegrated by the action of water or other means and still

preserve great compactness, as well as the conglomerates or pudding-stones, which consist of pebbles held together by some natural cement, are difficult to remove from the bottom of water. Their removal, however, may be successfully obtained by hammering or even by blasting or otherwise, by powerful dredges in which the buckets are provided with strong steel teeth. It is in the disintegrated and soft rocks that the method of breaking the material by hammering is considered the most economical. In many instances, disintegrated rock has been successfully broken by hammering. Of the different types of dredges, the one that gives the best result in digging through disintegrated rock and conglomerates is the dipper dredge; although those of the clamshell and ladder types have also been employed with advantage. The bucket of the dipper dredge used in these soils is armored with four strong steel teeth. These are forced into the conglomerate or disintegrated rock and by pulling up the bucket the material is dislodged and the débris falling into the bucket is raised to the surface. But when these compact materials are encountered at such a depth that the dipper dredge cannot work to advantage, both the ladder and clamshell dredges are found more adaptable. When the ladder dredge is used the buckets are provided with strong steel teeth and the endless chains driving the buckets are run with great velocity in order that the teeth may engage the compact material with great force. By means of a ladder dredge with armored buckets even large-sized stones can be removed from the bottom. Thus stones of over 1 cu.m. were picked up by the buckets of a ladder dredge in the harbor of Dunkerque in the English Channel. When the clamshell dredge is used the bucket is either entirely formed by strong tines or the edges of the bucket are provided with tines. The grab bucket lowered to the bottom at great speed will strike the rock with force and the tines will penetrate into the mass. By closing the bucket the rock will be broken and the débris will thus be raised to the surface.

Gravel. Gravel is a soil chiefly composed of small hard water-worn smooth fragments of rock ordinarily mixed with sand. When gravel is encountered in thick layers at the bottom of rivers or bays, it is generally a very compact material, so as to be considered almost as hard as any conglomerate. However, when it is attacked by the strong teeth of the buckets of dredges of various types, and a furrow has been dug through the bank, the small round pebbles

become very loose and are then easily removed by means of any ordinary dredge. The ladder dredge, with its buckets that are continuously scraping the loosened pebbles of the bank of gravel, thus filling up the buckets to their full capacity, seems to be the most efficient machine in this soil. The dipper and grapple dredges, however, are found very efficient machines for dredging through gravel.

Hardpan. Hardpan is a soil composed of loam and boulders and is considered very compact and resistant. Sometimes it is encountered in such a hardened condition as to be considered almost a conglomerate in which the cementing material is loam. Hardpans are met in numberless varieties, being christened by contractors with the strangest names. In the reports of public works, when the name of an unknown soil is mentioned, as a rule one may rest assured that is a variety of hardpan. Only three types of dredges can be used with advantage in this kind of soil, and they are the dipper, the grapple and the ladder dredges, in which the buckets are provided with strong steel teeth. The most efficient machine for digging through hardpan at shallow depths is certainly the dipper dredge. The large heavy bucket easily penetrates through the soil and being of large dimensions may loosen and lift boulders of any size. The grab dredge, provided with a clamshell bucket in which the edges are furnished with strong tines may be found very convenient, especially when dredging through hardpans located at a certain depth from the surface of water. The ladder dredge in which the buckets are armed with steel teeth for the double purpose of breaking the loam and facilitating the picking up of the boulders, can also be used for dredging through hardpan. In this soil, however, the ladder dredge, in some cases, may not be found so advantageous as the two other types of machines, owing to the fact that the buckets, no matter how large, may be too small for raising the boulders, especially when of large dimensions. Large boulders may entangle the buckets and disarrange the machine.

Clay and Loam. Clay and loam are as a rule considered among the loose soils, and yet they are the worst kind of such materials to remove. They stick to the buckets and cause a great deal of trouble. All the different types of dredges can be used with more or less advantage. The dipper and grapple dredges are considered the most efficient. With these machines the impact of the buckets in attacking the soil permits of easy penetration, thus filling the

buckets to their utmost capacity. But after the material has been raised to the surface it takes some time to unload the bucket, as the clay sticks to the sides and falls off with great difficulty. The ladder dredge is also adaptable to these soils, but the buckets must be of special construction to permit them to scrape into the bank of clay and be filled with the material, instead of sliding upon the surface of the bank; the buckets are provided with a sharp edge in the shape of a beak. After the buckets have dumped their contents they must remain exposed as long as possible to the air in order that the particles of clay sticking to the buckets may be partially dried. To facilitate this exposition to the air the buckets are run at very low speed and the tower supporting the revolving guiding drum is located as high as possible upon the frame of the boat. The hydraulic dredges are the machines most extensively employed to-day for dredging through clay and loamy soils. But in order to cut the material so as to be in condition to be drawn through the suction pipe and pass through the centrifugal pump, the lower end of the suction pipe is provided with a cutter or agitator.

Sand. Sand is one of the most common materials encountered in dredging. The greatest harbor and river improvements so extensively undertaken to-day throughout the world chiefly consist in removing sandbars along the estuaries of large rivers or seashores. Sand is found in different forms depending upon the mineral from which it originated. Generally speaking the sand is formed by the grains of materials rubbing one against another as they are moved onward in brooks and rivers or pushed backward and forward by the waves on a seabeach. Only the hardest materials that resist such a destructive action can produce sand, and for this reason it is usually found derived from quartz; the particles of softer materials are rapidly ground into mud. Sands are classified as coarse and fine, a distinction based upon the size into which their particles have been reduced. Coarse sands can be easily removed, even if they are mixed with gravel and shells, while it is more difficult to remove the fine sands, owing to the fact that the finely divided particles tend to float. An example of the different efficiency of dredging through these two varieties of the same material is quoted by Mr. Henry Satre. He says that a dredge employed in the improvement of the Harbor of Cette, France, used to remove 180 cu.m. per hour of coarse sand mixed with algæ, while it could

not excavate more than 45 cu.m. per hour when very fine sand was encountered.

The hydraulic dredge is the machine used to the best advantage in dredging through sand. The dipper and grapple dredges are objectionable owing to the fact that the fine material will easily escape through the seams of the bucket and consequently only a very limited amount of material will be removed at each lift of the bucket. The buckets of the ladder dredges, in passing over the bank of sand at great speed, stir up the material to such an extent that a large quantity of water will be taken up and only a small percentage of sand will be found in the buckets. The raising to the surface of such a large amount of water decreases the efficiency of the machine and increases the cost of the work per unit of volume. It is obvious that the finer the particles of sand are the larger the quantity of water will be in the buckets of the ladder dredges. Although the hydraulic dredges are considered the best-adapted machines for dredging through sand, yet in order to obtain the proper efficiency from these machines, the end of the suction pipe must be provided with some device that facilitates the separation of the coarse sand from its bank, so that when well mixed with water will be easily raised through the suction tube, and may also prevent the floating away of the fine sand under the stirring action of the pump.

Mud or Silt. Another soil which is very extensively encountered in dredging is mud or silt. This is composed of a finely powdered mineral matter mixed with organic particles derived from animal or vegetable sources, the powdered minerals being the result of the disintegration of soft rock by water and other natural agents. The particles of mud are so infinitesimally small and so finely divided they are carried in suspension by the running water, and are deposited in places where the water is quieter. Such a material is usually encountered as forming the bottom of the mouth of rivers, bays and harbors. The particles of mud are so finely divided they do not run away as easily as sands, but stick together in such a way that they can be removed with greater facility.

Dredges of any description may be used with advantage for the removal of mud. The dipper and grab dredges are found very useful for dredging through mud, especially when buckets of large capacity are employed. The ladder dredge also is considered a very efficient machine in this kind of soil. The rapid movement

of the buckets will tend to stir up the material to such an extent that its light particles may become loose again and float all around the point of excavation. To avoid this the chain buckets are run at a very low speed. As this reduces the efficiency of the machine it is overcome by using buckets of very large capacity. The hydraulic dredge, although very good in this kind of soil, has the disadvantage of stirring up the material to such an extent that it is mixed with a very large amount of water. Thus an enormous amount of power is required to remove a comparatively small amount of material. The large amount of water diluting the mud is considered an advantage when the débris is used to fill up low lands, as the water facilitates the equal distribution of the material over a larger area. On the other hand this surplus water is a hindrance when the material is pumped into the hold of the dredge to be carried to the dumping place, as in the hopper type.

UNIVERSITY OF TORONTO
DEPARTMENT OF CIVIL ENGINEERING

CHAPTER III

SOUNDINGS AND HYDRAULIC SURVEYS

IN order to estimate, even in an approximate way, the time and cost of a contemplated job of dredging, it is necessary to make an accurate survey of the locality. This should indicate the shore lines, soundings, obstruction to navigation as bars, sunken ledges, boulders, etc., giving all the data from which can be obtained a thorough knowledge of the place of the contemplated improvement. From this survey is deduced the amount of material to be removed from the bottom, in order to obtain the required depth of water; and from the amount of material is calculated also the cost and time required for the proposed work.

Any hydraulic survey consists of two distinct operations, namely, the measuring of the depth of water at various points and the location of the different points where the soundings are made.

Soundings. Soundings are made in three different ways: (a) by means of graduated rods, (b) by lead lines, (c) by automatic apparatus.

(a) Soundings are made by means of graduated rods which while resting on the bottom are kept vertical by the operators, who read directly the depth of water at each point. The operators, in small boats, go all over the part of the harbor or river to be improved, while the different points are located by any one of the various methods to be explained. Owing to the limited length of the graduated rods, this manner of making soundings is only applicable to localities with very shallow waters, and it is not accurate.

(b) Soundings are more commonly made by means of a lead line. This consists in lowering a weight of 10, 15 or 20 lbs. of lead attached to a graduated rope. The lead is shaped like the frustrum of a cone with the base hollowed out to hold some grease. The soil of the bottom adheres to the grease, and thus shows the nature of the excavation, which information should be entered in the field book and marked upon the map. The sounding line is made of strong

cord and divided into feet by different colored rags or other visible marks. Since the cord is liable to change its length it should be compared from time to time with some standard measure. Comparative tests of the two methods of soundings were made by Col. G. L. Gillespie, U. S. A. Corps of Engineers, in the harbor of New York, where part of the ground had been gone over by both methods. He found that the rod soundings showed a less depth than the line soundings by an average of six inches. In these experiments a 14-lb. lead was used and the line was compared at frequent intervals with a steel tape in order to verify its accuracy and when not in use was kept lying in fresh sea water.

(c) To make soundings by any one of the two methods just explained requires some length of time; to proceed more rapidly automatic soundings were devised. These consist either of a graduated rod or a sweep. In both cases the lower end of the apparatus is kept resting on the bottom, while the depth of the various points is recorded automatically.

On the Delaware River at Philadelphia the soundings were made from a long raft by means of a weighted wooden sounding rod, the raft being shifted transversely to its length, for successive rows of soundings, by long anchor cables. The method of the sweep was found of more practical application. Thus in the same work at Philadelphia was used a short horizontal sweep which was passed over the bottom; the sweep was either held by vertical gauge rods attached to a boat which was rowed over the ranges, or it was manipulated by a diver working from a scow in tow of a tug.

Based on the same principle of a sweep bar, a new device for recording automatically the various soundings was constructed by Mr. R. M. Pardessus and described in the *Eng. News*, Vol. XLIX. The apparatus is carried by a barge which is moved along fixed ranges in tow of a tug at uniform speed. The sounding is made by a transverse sweep bar fastened to the outer ends of two arms, which are pivoted one on each side of the barge and extend rearwardly down into the water. The sweep is made of a piece of railroad rail to give the necessary weight. At the upper end of the hinged arms is a recording apparatus which marks the profile of the bottom on a strip of paper moved by clock-work. The speed of the tug and the motion of the paper being adjusted to a known ratio, the curve traced on paper is a scale profile of the bottom along the range over which the sounding barge is towed.

The Survey. The second important operation required in hydraulic survey is the correct determination of the points where soundings were made. This is obtained in three different ways, which are: first, by triangulation from shore stations; second, by sextant observations from the boat; third, by running the boat over known ranges and spacing the soundings by time.

First. The location of the various points where soundings were made is determined very correctly by means of triangulation from shore stations. A base line is selected along the shores so as to command a large view of the locality to be surveyed. The line is correctly measured either directly or by triangulation. At the extreme ends of the base line are set up two transits, with very distinct graduation, in order to make angle readings very promptly when signals are given. The operators take simultaneous "shots" or readings of the angles at the same instant that the soundings are made. These are obtained by means of conventional signals from the men in the boat, who indicate the moment that the readings should be taken.

Second. Soundings are located also by sextant observations by the men in the boat. For this purpose three points are selected on land, such as can be seen along the line of the improvement to be surveyed and whose geographical position has been correctly determined. Soundings are made by a surveying party on a boat running with a velocity of $1\frac{1}{2}$ or 2 miles per hour; while the location of the various points is determined by reading with sextants the angles that the boat makes with the three land points. This method is now extensively used by the U. S. Coast and Geodetic Survey and it is based upon a simple principle of geometry.

Let L, C, R (see Fig. 1) be the three fixed land points and P the unknown position of the boat. The angles A and B are read with sextant.

Draw two circles, one passing through L, P and C , and the second through C, P, R . Now from geometry it is known that by connecting any point of the circumference with two other fixed points on the same circumference, the angle will be constant. The two circles intersect at the points C and P , and since C is one of the fixed points, so there is but one point P where it is possible to have the angle $C, P, R = A$ and $C, P, L = B$. Therefore these two angles determine the position of P .

By setting off on a three-armed protractor the two angles A

and B and shifting it until the plotted position of the points R , C and L are each on the edge of an arm, the center of the protractor will be on the point of sounding where the angles were taken. There is but one exception to this rule; that is, when the point P is on the same circumference passing through R , C and L ; then its position is indeterminate (see Fig. 2); generally when signals are from 3 to 5 miles the angles read within 2 or 3 minutes of their correct value, the point can be plotted within 5 or 6 ft. of its true position. This is sufficiently accurate for hydrographic work, for on any scale smaller than $\frac{1}{100000}$ 5 or 6 ft. is not a hair breadth and very few charts are on a scale larger than this.

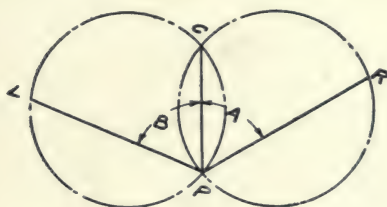

FIG. 1.

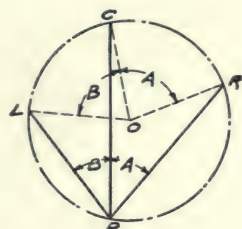

FIG. 2.

Third. Another method is by running a boat over a known range at a certain speed and taking soundings every 1, 2 or 5 minutes, or at intervals depending upon the importance of the proposed improvement. Thus, for instance, if a boat is running at a speed of 2 miles per hour and soundings are made every 3 minutes, they will be 80 ft. apart, and when the course of the boat is known it is a very simple matter to locate the various soundings, thus obtaining a survey of the bottom.

No matter which method is used, in taking and locating the soundings it is evident that a topographical map of the bottom can be easily drawn from the field notes. Great care, however, should be taken in reducing the soundings to an ideal level, which is generally the mean low water mark. Consequently the correct time at which the soundings are made should be accurately recorded so as to compare them with the height of the tide at that time, and all the soundings reduced to a common plan, which is the surface of the mean low water.

Measurement. A topographical map of the bottom of the body of water, indicating the depths of various points of the bottom from the surface of the water, with mean low water as a datum line, is

made from the field notes. Either on this map or a similar one the required depths are marked, hence by comparison the total depths of material to be removed are easily calculated. A series of cross sections can be taken at some distance apart and thus the volume of the excavation between the consecutive cross sections is determined. The amount of cubic contents between the various cross sections will give the total amount of material to be removed in the proposed work. The manner of calculating the cubic content between the consecutive cross sections is exactly the same as for land work, namely by the mean end area or prismoidal formula. Generally only the former method is used.

Place Measurement. Engineers have two methods for estimating the amount of the dredged materials—by place measurement and by scow measurement.

When specifications state that the amount of the dredged material will be measured in place, it means that it will be deduced from two hydraulic surveys made, one before the work begins and the second after the improvement has been completed. The difference between these two surveys will represent the total amount of material removed to obtain the required improvement. In practical work a series of transverse cross sections are drawn on the plan of the proposed improvement, extending all through the width of the work. The area of the cross sections indicating the amount of material removed is given by the difference of the two hydraulic surveys.

Scow Measurement. The second method of determining the amount of dredged material is by scow measurement. This consists in measuring the capacity of the scows or boats that carry away the excavated materials and deduce the total amount of the dredged material from the number of boats employed in transporting the materials to the dumping place. This method can be compared to the one sometimes used on land in which the amount of the excavation is deduced by tallying the vehicles that are carrying away the excavated *débris*.

The scows used in connection with dredging are of several different types but chiefly the deck and dumping scows. When deck scows are used, the hold of the boat is correctly measured by the engineers of the two parties and the cubic content of the scow is then used for measuring the material removed from the bottom. When the dumping scows are used for the transportation of the *débris*,

the cubic content of each compartment is accurately measured and the solidity of the various compartments of the scow taken as the base for estimating the amount of the dredged material. When instead of scows, the dredge is provided with hoppers, the cubic content of the various hoppers are used for the measurement of the material excavated from the bottom.

The amount of the excavated materials deposited into the scows to be transported to the dumping place can be also measured from the draft of the scow itself. There is no doubt that the more material deposited into the scow the greater will be its draft; by gauging the draft of the scow when empty and when it contains a certain determined load of 100 tons, for instance, the difference of the two drafts will indicate the content of the load and from these two points a scale can be made for the fractions of the load as well as its multiples. From this graduated gauge the content of the scow can be easily deduced.

In the construction of the new stone breakwater at Buffalo, N. Y., all the stones were paid for by the ton, and were transported by means of scows, either of the deck or dumping type. For the purpose of measuring the amount of material transported, each vessel was provided with glass gauges and graduated rules by which the draft of the vessel was ascertained. A number of deck scows were built especially for the work and exact measurements of these vessels were made before launching. From the data thus secured elaborate tables were prepared showing the displacement for every $\frac{1}{100}$ of a foot, calling the bottom zero.

The glass gauges were placed on the keel forward and aft, and consisted mainly of a wrought-iron standpipe 3 in. in diameter, into which two brass cocks are screwed. Between the cocks, which are from $4\frac{1}{2}$ to 7 ft. apart, depending on the sizes of the scows, was placed a glass tube about 1 in. in diameter, the whole apparatus resembling a water glass gauge as used on a boiler. A wooden rule graduated in feet, tenths and hundredths was attached alongside of the glass tube.

The graduations of the rule corresponded exactly with the draft of the vessel. This was usually accomplished by taking the mean draft of the vessel fore and aft, and setting the rules to correspond with the water in the gauge. Absolutely quiet water was required for this work, and to facilitate it marks 6 in. apart were accurately cut into the sides of the vessels at each end. To determine the load

of a vessel, the mean readings of the gauges were taken when the vessel was light and again when loaded, difference between the light and loaded readings as taken from tables gave the desired information. Vessels which could not be measured on the ways or in docks were measured on the water, their draft being obtained by hook gauges.

To check the calculated displacement, the load of a vessel was actually weighed at frequent intervals, by means of a track scale, located at the contractor's quarry. Remarkable agreements were found between the two.

In the case of dump scows it was not possible to obtain the load carried by displacement, and the value of the gauge readings was, therefore, determined by actually weighing the material on the track scale, the readings of the gauge being taken when the scow was light, and with frequent partial loads and when fully loaded. The difference in feet and decimals of the gauge readings divided into the total load gave the ratio per foot. This only applies to full loads. Partial loads, as well as large or small-sized stone, affect this ratio somewhat.

Increase and Shrinkage of Material. There is a great difference in the cost of dredging when the material is measured in place or in scows. When the specification states that the material will be measured in place, two important items should be considered. These are the increasing of volume of the removed materials, due to the fact that the soil removed from its natural position increases in volume, and such an increase is by no means a transcurable quantity. The second item is due to the work of the subcurrents, which tend to stir up the material and fill up again the place of excavation. This is caused by the leveling action of water, especially in very soft soils, as fine sands and muds, and as a consequence necessitates the excavation of a larger amount of material, in order to obtain in a permanent way, the depth required by the improvement.

It will be almost impossible to foresee the amount of material that will fall back into the excavated place, since this depends upon two factors, namely the direction and strength of the currents and the looseness of the material. It is very difficult to tell how far the currents will affect the soil at the bottom of the improvement, and to estimate even in an approximate way the amount of material that will fall back. It will be advisable for the con-

tractor to make allowances for this item and roughly estimate the increased quantity to be excavated, after a careful examination of the local conditions of the improvement. In a general way it can be said that this quantity is always less than 10 per cent of the total amount of the excavation.

Better known is the increase in volume of the excavated material, which has to be transported to the dumping place and for which no compensation will be given, hence the expenses of transportation of this large quantity of material should be included in the cost of excavation. Writing from the experience gained with the United States sea-going hydraulic hopper dredges Manhattan and Atlantic, employed upon the Ambrose Channel in New York Harbor, Mr. Henry N. Babcock says that each dredge was provided with two almost equal sandbins, both carrying together when fully loaded about 2300 cu.yds. But ordinarily a dredge would take in a load of 2200 cu.yds., approximately 1800 yds. in place. Thus according to the experience of the U. S. Engineers in the Ambrose Channel the increase of volume was estimated at 400 cu.yds. per each load of 2220, or in other words it was noticed a difference of 22 per cent between the material measured in place and in the hoppers of the dredges. The total amount of the excavation required by the improvement of the Ambrose Channel was estimated at 40,000,000 cu.yds. measured in place. Thus it necessitated the transportation of nearly 9,000,000 cu.yds. without any compensation. A very expensive item indeed, when it is considered that the transportation of this material was effected by the same steamer dredges which excavated the bottom. This meant they suspended operations and steamed out to sea, making a trip of nearly 8 miles from shore, to dump their content into deep waters. It took over 400 of these trips to dispose of the increased volume of the material, involving as a consequence a very large expenditure. Since the increasing in volume should be always considered by contractors in preparing bids, especially when the material will be measured in place, it will be convenient to consider the increasing of volume at 30 per cent when there are not more definite data.

Mr. Robinson, in his article on Excavating and Dredging Machinery in Engineering Magazine, in regard to the work of the hydraulic dredge J. Israel Tark says: The quantity of work done was ascertained by taking the position of the dredge on the first of the month and again on the first of the following month, and measuring the

distance of length of ship channel completed in that time. As the cross section of the cut was practically uniform and the material blue clay, which remains permanently in place, the work of the dredge could thus be arrived at with a fair degree of accuracy. The quantity stated is increased to scow measurements to compare with the other dredges on the same work which load into scows, on the basis of place measurement being 80 per cent of scow measurement.

CHAPTER IV

EXCAVATION OF SUBAQUEOUS ROCKS. GENERAL DISCUSSION. EXCAVATION BY HAMMERING

Rock is the most difficult and expensive material to be removed from beneath the water. When, in carrying out the work of harbor or river improvements rock is encountered, its excavation involves two distinct operations:

(a) The breaking of the rock into small fragments.

(b) The raising of the débris to the surface and its disposal in any convenient manner. This last operation is accomplished by means of any ordinary dredge, while the breaking of the rock into small fragments is done in two different ways, viz., by hammering and by blasting.

The Method of Hammering. The breaking of the rock into small fragments, by hammering, is accomplished by means of devices which strike powerful blows. The blows are delivered by gravity, when an extra heavy weight falling from a certain height strikes the rock, as in the Lobnitz machine; or by steam or compressed-air engines, when the rock is struck by iron bars placed in continuation of the piston rod of a vertical engine, as in the Scott & Godsir cutters. No matter which method is used the rock is reduced into fragments of such size that they can be easily picked up by any ordinary dredge, and in some cases though material is pulverized in such a way that the finely divided particles can be carried away by the current.

The Method of Blasting. Submerged rocks can also be excavated by blasting. Different methods are used, depending upon the magnitude, depth and location of the rock to be removed. When the rock is entirely submerged and must be removed from an extensive area, but in shallow water, the most common method is by successive small blasts as in the excavation of rock in the open air. The only difference being that more powerful drilling machines are used and they are mounted on scows or stages of special construction.

These machines drill vertical holes which are charged and fired in round as soon as a few holes have been drilled.

The rock to be removed may form a large reef extending to the surface. This may be located in the way of navigable channels and form serious obstacles to navigation. Such rocks being isolated, in the middle of large bodies of water, and far from important buildings, are conveniently removed by a huge single blast. Such a blast can be prepared by honeycombing the rock, by sinking shafts and driving small radiating headings at different levels and from these drilling holes in all directions. These numerous holes are charged with explosives and are fired simultaneously. This method was used in blasting the Flood Rock at Hell Gate, in New York Harbor. Another method of removing isolated reefs consists in building a coffer-dam all around the rock. Within the coffer-dam the rock is removed in the usual way as in land work until the pit has been excavated to the required depth. Then lift holes are driven all around underneath the ring of rock supporting the coffer-dam. The holes are charged and fired simultaneously and the ledges of rock surrounding the pit together with the coffer-dam are then broken and shattered by the explosion and reduced to small fragments that can be easily picked up by dredges. This method, called "lift holes," was used in removing Henderson's Point at Portsmouth Navy Yard, New Hampshire.

The following machines and methods have been used to break subaqueous rock by hammering:

Scott & Godsir Cutter. This machine (see Fig. 3) was designed and built in 1897 by Messrs. R. M. Scott and A. Godsir in Sidney, New South Wales, and described by Mr. Charles Graham Hepburn in the Transactions of the Inst. of C. E. This rock-breaking machine consists of a drilling tool connected directly to a piston, reciprocating in a steam cylinder of considerable length, which is carried on a vertical slide or carrier, capable of vertical adjustment on a tower erected on a barge, pontoon or other floating structure.

The drill varies with the class of work to be done. For ordinary rock excavation the head is formed of three drills forged from a steel bar 6 in. by 4 in. in cross section. The drill is secured to the end of the piston rod by means of a cotter. The cylinder is 14 in. in diameter and 5 ft. in length; the piston rod is 6 in. in diameter at its top and increasing to $7\frac{1}{2}$ in. in diameter at the lower end, and is guided by three bearings. To obviate the danger of the piston

striking the bottom of the cylinder with sufficient force to cause injury to the cover, a supplementary steam-pipe taking its supply from the valve casing is led into the bottom of the cylinder. This arrangement insures a constant supply of steam at boiler pressure on the lower side of the piston, acting on it as a brake or buffer in its descent. The cylinder is securely bolted to the carrier. This is formed of two square-edged vertical beams 12 x 12 in. and a framing of 12 x 6 in. timbers bolted together so as to provide a rigid structure. The carrier slides vertically along the faces of the tower and has its movements controlled by a steam winch. The carrier is secured from transverse movement on the tower by a T-shaped guide or retaining piece bolted to its

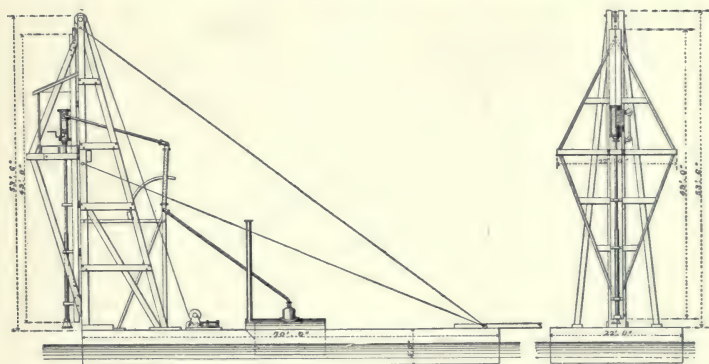

FIG. 3.—Scott & Godsir Rockcutter.

vertical timbers and sliding between the two upright timbers of the tower and engaging them on their back. The carrier is provided with a shelter for the steam cylinder and the operator. Also the tower consists of two vertical beams, each 12 in. square in cross section, set 1 ft. apart and braced with diagonal struts and steel grip wires. The steam is conveyed from the boiler to the cylinder by means of a 4-in. steam pipe, trunnioned at the joints to permit of vertical movement. One of the pipe-lengths is guided by a quadrant piece and is reinforced by timber bolted to the pipe, which bears against the quadrant.

In regard to the efficiency of this machine, it was found that when the moving parts weigh about $3\frac{1}{2}$ tons and the stroke of the piston is about 4 ft., making 60 strokes per minute this apparatus will break more than 30 cu.yds. of solid rock per day.

Steam Punch. In the year 1854 Mr. Charles T. Harvey, the designer and builder of the first New York elevated railroad, while engaged in the construction of the St. Mary's Falls ship canal was compelled to remove a ledge of solid rock, over 1000 cu.yds., encountered on Lake Superior, just at the mouth of the canal. He had only a dredge of very small capacity, which was of no use for such work. He constructed a new machine which he called a steam punch, described by Mr. Benjamin E. Buchmann, as follows:

The machine consisted of a shaft, which, dropping, struck on the submerged rock with a force of 20 tons per sq.in.—a blow that no rock could withstand. He used a wrought iron shaft 16 in. in diameter and tapered down to 1 in. square steel-faced point. To this was welded a socket formed out of the wrought iron fluke of a propeller's wheel. Into this socket was keyed the end of a heavy oak timber to form the punch or chisel, weighing altogether over a ton, and striking a blow, as stated, of 20 tons per sq.in. By a system of gauges and stops it was known when the punch had penetrated below the desired depth, when it was moved a given distance dropped again, until the submerged rock was broken into such fragments as could be readily removed by the dredge. The required machinery was mounted on a scow. It took 6 weeks to break the ledge, which was from 1 in. to 3 ft. higher than the required level.

Thus the method of breaking subaqueous rock by falling weights used in the Lobnitz machine was employed in the United States some years ago.

Lobnitz Rockcutter. Messrs. Lobnitz & Co. of Renfrew, Scotland, have constructed a very efficient rock-cutting machine which has been extensively used in difficult subaqueous excavations all over the world. It was successfully employed in the deepening and widening of the Suez Canal. The Lobnitz machine was illustrated in Engineering from which this slightly condensed description was taken.

The machine (see Fig. 4) is built on the principle of a floating pile driver; but the monkey of the latter is replaced by a heavy rod of steel armed at its lower end with a renewable ogival head. This steel ram or chisel may weigh complete from 4 to 20 tons and is allowed to fall from a height of 6 ft. to 10 ft. on to the rocky bottom to be excavated. The weight of the ram used depends not only on the hardness of the rock, but also on the depth of the water,

the rule adopted by the makers being to make the ram 1 ton in weight for each meter of depth. The whole force of the impact is concentrated on a few square inches of rock surface, so that the hardest rock is readily split and pulverized.

The ram falls through a well in which is a fixed hardwood guide. This guide is short and loose fitting, and it therefore permits the cutter a certain degree of freedom in an angular direction. The guide is mounted so that it can be adjusted vertically to suit different depths of water and is provided with renewable wearing plates and spring cushions to deaden any shock.

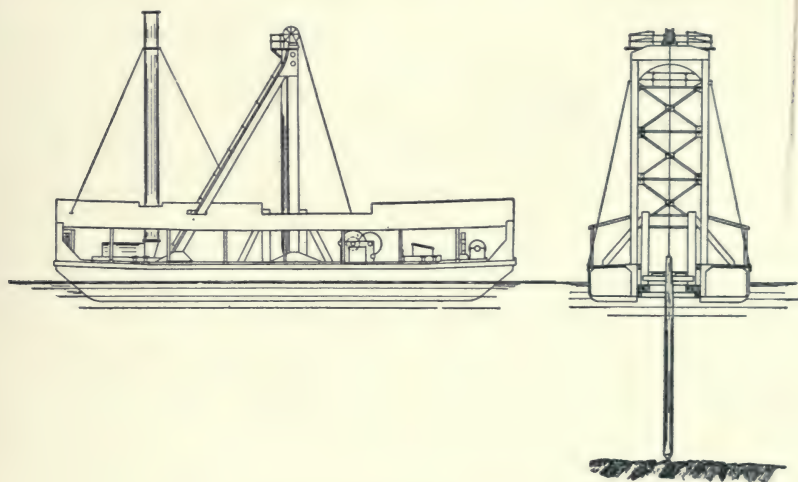

FIG. 4.—Lobnitz Rockcutter.

The cutter bars are provided with ogival heads, having a center harder than their circumference and consequently are self-sharpening, the rock wearing away the hard center less rapidly than the softer surrounding metal. The other end of the ram is attached to a wire rope which is wound around the drum of a hoisting engine. The rope drum is loose on its shaft, being driven by a friction clutch, which is automatically thrown into gear the instant the ram reaches the rock. This is effected by a bell crank lever carrying a sheave which is pressed against the lifting rope by a weight on the short arm of the bell crank. When the ram reaches the rock the lifting rope slackens, and as a consequence, the bell crank lever moves forward under the influence of the aforementioned weight, and this

movement is caused by suitable connections to throw the friction clutch into gear.

To break the rock the ram is dropped on the same spot time after time till the desired depth is reached; but if a greater depth of excavation is needed it is usual to execute the excavation in installments, first breaking up a layer 3 ft. to 6 ft. thick, this thickness depending on the character of the rock. The broken rock is then dredged away, and the work resumed on the cleaned surface till the desired depth is attained. In finishing off, this depth should be about 9 inches more than the depth of the excavation so as to make certain that the dredge buckets on removing the débris shall meet with no obstruction. It is very important that the ram should fall exactly on the same spot on repeating its blows, a movement of even a few inches reducing the efficiency of the machine. Accurate maneuvering is thus very important, and this is obtained by means of sighting rods which are collimated with base lines placed on land. During work, the man in charge constantly controls the position of the barge by keeping his eye on the sight-rods. After the work is finished in one spot it is necessary to move to a fresh one about 3 ft. away. This is done by means of six mooring chains operated with steam winding gear.

In practice it is found that it is best to space the blows 3 ft. apart. If wider spacing is adopted a greater quantity of rock is loosened, but it is not as completely broken up and therefore cannot be dredged economically. With 3 ft. spacing, approximately 50 per cent of the whole mass is absolutely pulverized, and the sand thus formed, if there be a strong current, is washed away. In hard rock at least 2 cu.ft. are, on the average, broken per blow, so that, with a single-cutter machine about 9 cu.yds. may be taken as effective work. The machine can be built either with one or with two rams. The efficiency of the double-cutter machine is almost double that of the single one. To handle the machine a crew of six men is required in the case of a single cutter, and eight for a double cutter. The former will consume 1 ton of coal per ten-hour day and the latter 1½ tons.

Concerning the progress and cost of the work of the Lobnitz machine Mr. W. Henry Hunter, chief engineer of the Manchester Ship Canal, has given the following report:

MANCHESTER SHIP CANAL; DEEPENING FROM 26 FT. TO 28 FT.;
LOBNITZ ROCKCUTTER No. 1.

Average quantity (over a period of ten months) of rock broken up per month.....	6403 cu.yds.
Average cost of breaking.....	8.94d. per cu.yd.
Minimum quantity of rock broken per month.....	5622 cu.yds.
Maximum quantity of rock broken per month.....	10180 "

The cutter has worked on double shift regularly, and the average cost of working in this manner has been £240 per month, made up as follows:

Wages.....	£108
Coals and stores.....	27
Repairs and renewals, including new ropes and repairs to needle.....	105
	<hr/>
	£240

The rate of advance of the rockcutter averages 36 ft. per diem, the bottom width of the canal being 120 ft.

(Signed)

W. HENRY HUNTER.

ENGINEER'S OFFICE, June 19, 1906.

The Lobnitz rockcutter has just been introduced in the United States by Mr. Lindon W. Bates, former president of the Empire Engineering Corporation of New York in the work at Black Rock Harbor and the channel of the Niagara Ship Canal. The machine used by Mr. Bates was thus described in the Engineering Record, March 16, 1907.

The rockcutter which is to be employed in the Black Rock Harbor and channel was especially designed for this work by Mr. F. W. Allen, engineer for the Empire Engineering Corporation. The hull is composite, being composed of two separate hulls, each 96 ft. long and 17 ft. beam, which are fastened together by screw clamps, forming one hull 96 ft. long and 34 ft. beam when in service. The hull draws about 3 ft. 6 in. of water when fully loaded, and the rockcutter is ready for operation. The object of building the hull in two parts is to allow each hull to pass the locks of the present Erie Canal, in case the rockcutter should be dismantled for shipment to other points.

The essential part of the rockcutter, of course, is the cutter, which was made by the Bethlehem Steel Co., Pennsylvania. It is a steel cylinder, 28 in. diameter, about 25 ft. long and weighing 46,000 lbs. It is fitted at the lower end with a hardened steel conical-

shaped point, resembling the end of a projectile. At the upper end there is an eye to which a steel cable is attached, leading from a very powerful steam winch of special design, built by the Lobnitz Co., of Renfrew, Scotland.

The hull is maneuvered by a six-drum steam Mundy hoisting engine, by means of six $\frac{3}{4}$ -in. wire cables, each 1000 ft. long. One of these leads forward from the bow, one aft from the stern, and one each from the four corners to port and starboard. The anchor cables pass from the drums through the deck sheaves, and run out from the deck level to the anchors, previously placed in position. After the machine has been placed, the steel cylinder is raised by the hoisting winch, and then let fall onto the bed rock. This operation is repeated until the desired result is achieved. The hull is then moved to a new position by taking in the cables on one side and paying them out on the opposite one, after which the rock crusher is raised and let fall, and so on.

Steam is furnished by a large locomotive boiler. The machine is also supplied with an electric plant and searchlight for night work.

The contract price for removing the bed of rock on this work is \$1.85 per cu.yd. measured in place.

An American company has lately been organized to manufacture and sell rockcutters of the Lobnitz pattern.

There is also now being used in this country a rockbreaker or cutter that instead of the hammer falling in a shaft by gravity, it operates in a compressed air cylinder. It is claimed that a more powerful blow is struck in this manner and the blow is controlled. Except for air being used the principle is similar to the Scott & Godsir cutter.

CHAPTER V

EXCAVATION OF SUBAQUEOUS ROCKS—BY BLASTING— COMPARISON OF THE TWO METHODS

SUBMERGED rock can be removed by small successive blasts fired in rounds as quickly as the holes are drilled and charged. Such a method is used in the excavation of submerged rock encountered at a comparatively shallow depth and for some years has been the most common method of removing subaqueous rock. Blasting rock in connection with dredging was done in England years ago. The Encyclopedia Britannica mentions the works of Rennie at Newry and Stevensons at Ballyshannon as executed in this manner. The same method was afterward extensively used by Mr. William Cubitt on the Severn. It was described by Mr. Evans in the Proc. Inst. of C. E., Vol. IV, and condensed as follows:

Drilling Plants. In removing marl beds along the channel of the Severn, after the dredges had been unsuccessfully employed, new methods were tried, one of them consisting in scraping the bottom of the channel with a plow, another to drive into the hard soil iron rods, so as to loosen the material. However, it was decided that the only possible way was to recourse to blasting. For this purpose, from a raft moored into the river were lowered iron pipes $3\frac{1}{2}$ in. in diameter and sunk well into the marl. Through these pipe holes were bored first with a $1\frac{1}{2}$ -in. jumper and then with an auger. The holes were bored 6 ft. apart each way. The cartridges were formed in the ordinary way with canvas and fired with Blickford fuses.

In breaking rock by blasting on the Rhine River, between Bingen and Coblenz, in the year 1863, Mr. Hipp successfully employed a new device for drilling holes, which has been in constant service until very recently. This consists of a drilling machine in which the drill 5 meters long was fastened to the axis of the piston. It was raised by steam power and let fall by its own weight. The weight of the rod was from 150 to 200 kg. and the machine was able to

strike from 110 to 130 blows per minute. It took from 10 to 15 minutes to sink holes 8 cm. in diameter to the depth of .05 to .1 m. With these machines from 8 to 10 holes from 1 to 1.80 m. deep were made in a day.

In this country, in the year 1866-67 Mr. Dunbar used a method of his own for blasting a rock bed from the channel and harbor of Erie, Pa., on Lake Erie. It was described by Mr. Dean in the Proceedings of the Am. Soc. of C. E.; the ledge of rock excavated was only 6 ft. deep. It was drilled by hand by means of jumpers or crowbars, the men standing on the ice in winter and on a specially constructed raft in other seasons. The thickness of the ice guided the drills to strike their blows in the same spot. The raft was rigged with a device so as to make the drills repeat their blows in the same place.

This rough device led to the design of the modern drilling machine. In the year 1872 Mr. Dunbar undertook the excavation of a submerged rock at Port Colborne, Lake Erie, and the drilling was done by hand. The rock, however, was so hard that three men could hardly drill 1 ft. per day. Accordingly Mr. Dunbar constructed a drilling machine, using the hull of an old dredge to carry the machinery. The scow was provided with vertical spuds at each corner to hold it firmly in position. A track was laid on the edge of the deck on which the drills were moved. On this track were mounted two 5 in. steam-cylinder percussion drills, arranged to slide up and down in a vertical frame overhanging the side of the scow. The drills were raised or lowered by means of a windlass operated by hand, and were moved along the track by means of crowbars. The scow was 50 ft. long, and by starting one drill at the end, and the other at the middle of the track, each drilling five holes at intervals of 5 ft., it was possible to drill ten holes from one position of the scow. Holes 9 ft. deep could be drilled without changing the drill bits for longer ones. As soon as a hole was drilled to the requisite depth, it was charged and blasted without moving the scow. When one row of holes had thus been disposed of, the scow was moved back from the face of the excavation a distance of 6 ft. and the operation was repeated.

This method of drilling holes was afterward greatly improved. A hydraulic ram was introduced in order to move the drills both vertically and horizontally. The great inconvenience arising from the débris which filled the bottom of the hole, thus forming a cushion

and preventing the bit from striking the rock in the successive blows, was obviated by the introduction of a pump which forced a jet of water into the drill holes for the purpose of cleaning them of débris.

Fig. 5 shows a modern plant for subaqueous drilling designed and used by Mr. William L. Saunders for the removal of rock in New York Harbor. It consists of an old scow or hulk, upon which are housed the boiler room, the engine room and the blacksmith shop, and a detached drill stage, which is, however, connected to the

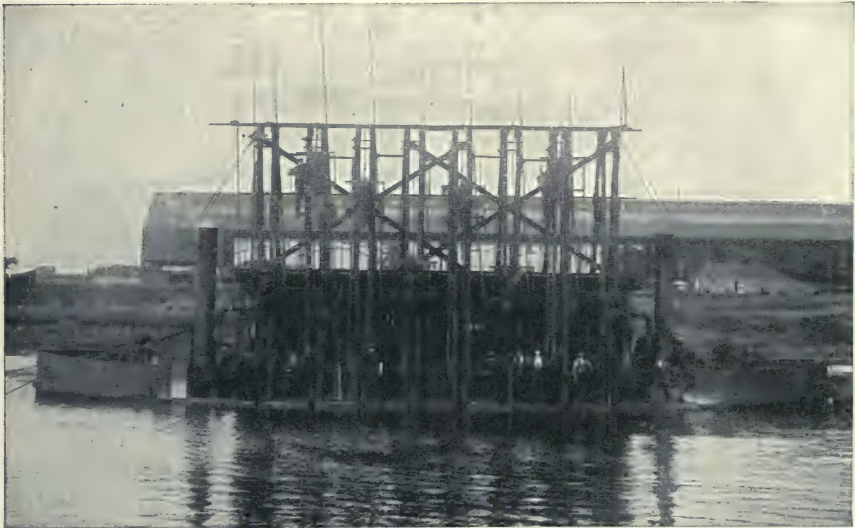

FIG. 5.—Saunderson's Machine for Subaqueous Rock Excavation.

boat by a gangplank. The drill stage chiefly consists of a wooden platform supported by four adjustable legs sliding into castings, so that they may be adjusted to any height and regulated according to the tides, so as to have the platform always above the water-level. The platform or stage is provided with slots cut both in the longitudinal and transverse direction in order to allow the points of the drills to go through. Located on the stages are two drilling machines of the automatic-feed type mounted on tripods. They are provided with an extension piece operating through a submarine tube, which extends underneath the platform, and is used to direct the blows of the drills. These drill stages will stand heavy blasting.

This was proven at New York, where at times hundreds of pounds of dynamite were blasted under the platform without injuring it.

In blasting rock at the Iron Gates on the River Danube a different device was used, shown in Fig. 6. This consists of a floating rectangular platform provided with four spuds of large dimensions which can be raised and lowered by means of chains, each commanded by a windlass. In this way the platform can be either made to float so as to be easily transported from one point to another, or firmly fixed to the bottom. A very long pit provided with tracks on the edge of the longitudinal sides is located in the center of the

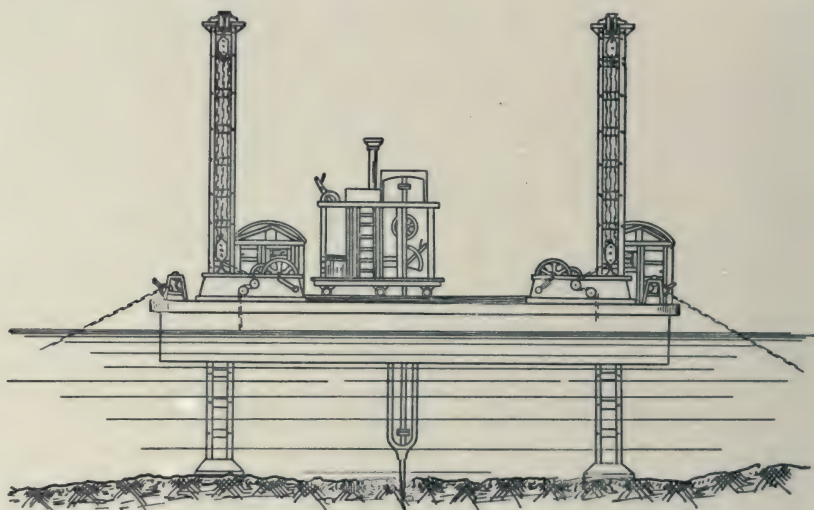

FIG. 6.—Drilling Platform used on the Danube River.

platform. A platform with boiler and engines and carrying four drills of the rotary type is mounted on a truck running along the tracks. The drills are mounted 5 ft. apart and by moving the truck from one end to another of the long pit, many rows of drill holes can be bored. After all the holes have been charged the spuds are raised and the float moved 50 or 60 yds. away, to return and resume work after blasting all the holes, by means of wires attached to an electric machine located on board the float.

For blasting subaqueous rocks there are other drilling machines in which the drills instead of working through pits in the middle of the float, are located at the edges of the boat. These machines may

be provided either with one or several drills. Fig. 7 shows a single drilling machine as built by the Ingersoll-Sergeant Co. This consists of an ordinary scow or pontoon supporting a wooden frame similar to the one used in connection with a pile-driving machine, and erected on the front edge of the pontoon. A drill of large size is mounted on these leads. The leads can be made of any desired length and are equipped with a hand and power feed, used for raising the drill in the leads or guide. An automatic lead is provided for feeding the drill down as it cuts away the rock. The drill and feeding arrangements are fastened to a spud which is placed between wooden



FIG. 7.—Ingersoll Drilling Scow.

or iron guides for the purpose of raising or lowering the apparatus to suit the various depths of water. The drilling is done through a tube which rests on the rock and supports the weight of the spud carrying the drill. The drill steel is hollow and has a valve placed in it near the bottom, which acts the same as a pump, the cuttings being forced up and out at the top. The drill is operated from a boiler located on the deck of the scow.

To blast large quantities of rock in a comparatively short time, more powerful machines are employed. These consist of scows carrying a whole battery of drills, together with their equipment. In such a case the boiler must be proportionate to the work required

by a larger number of drills. These machines are similar to those described above, the only difference being that three or four drills are mounted either on the port or starboard sides of the pontoon and their distance apart being equal to the required distance of the drill holes. Fig. 8 shows one of these machines as built by the Rand Drill Company.

A uniform bottom cannot be obtained by blasting the rock in the manner just described, on account of irregular ruptures caused by lack of uniformity in the quality of stone. When it is desired to have a level bottom the drilling must be made from a shaft or



FIG. 8.—Rand Drilling Boat.

caisson. The shaft can be constructed of different materials, but it is more convenient to build it in the shape of a metallic caisson suspended from a boat, or better, between two boats close together with a space for the caisson between them. After the boat or boats have been anchored and made firm to the bottom the caisson is let down to the bed of the river and the water forced out by means of compressed air, which is also used for operating the drills. The holes are drilled about a yard below the desired level of the bottom. After the dynamite cartridges have been put in place the boat is pushed off to one side for a distance of about 130 to 160 ft., all the cartridges being exploded simultaneously by electricity; then the

boat is brought back into position for blasting and the shaft is sunk again. The loosened rock can be removed either through the shaft, which is a comparatively slow operation, or can be removed later by means of dredges. The principal advantages of such a shaft consist in the facility thus offered for examining every part of the bottom and leveling it by hand where necessary and in the ease with which the seat of operations can be changed without loss of time.

The boat shown in Fig. 9 with a central opening for the metallic caisson was found very convenient in blasting rocks on the Rhine River where the machinery had to be moved frequently to make room for the passage of floats and tows made up of a number of boats. Each of the shafts employed there covered a surface of about 27.5 sq.yds. in which as a rule, fourteen to seventeen holes were drilled. The blasting operations extended over a surface of 49 sq.yds., so there was one hole for about 2.7 sq.yds. of blasting surface. On an average 360 ft. of hole was drilled per day by one shaft. During the operations in the Rhine, near Bingen, about 260,000 cu.yds. of stone were blasted out.

A similar device is also used in California in connection with gold mining. There the river beds carry much fine gold, and by dropping a small caisson from the center of the boat men are able to go to the river bottom, excavate the gold-bearing sand and gravel and by means of hoisting machinery elevate it to the separators on board the scow. Such caissons are much smaller than those used for rock drilling. The use of such caissons, however, has not been extensive, and their value is disputed among mining engineers.

Excavation of subaqueous rocks can be done in some cases without any previous drilling, by simply placing dynamite cartridges on the ledge of rock at the bottom of the river. In such cases the rock is broken into slabs and the fragments are carried away by the current or are raised by dredges. It is obvious that with this method of blasting subaqueous rocks, a larger quantity of dynamite should be used than with the usual manner of blasting by drilling holes to receive the charge. Consequently it is seldom used except when a small quantity of rock must be removed and the ledge is thin.

Blasting. After the holes have been drilled by means of any one of the numerous devices already described, they are charged with explosives. There are several methods of charging drill holes, but the one most commonly used was devised by Mr. Dunbar, the pioneer of subaqueous drilling. Mr. Dunbar's apparatus consists of a cop-

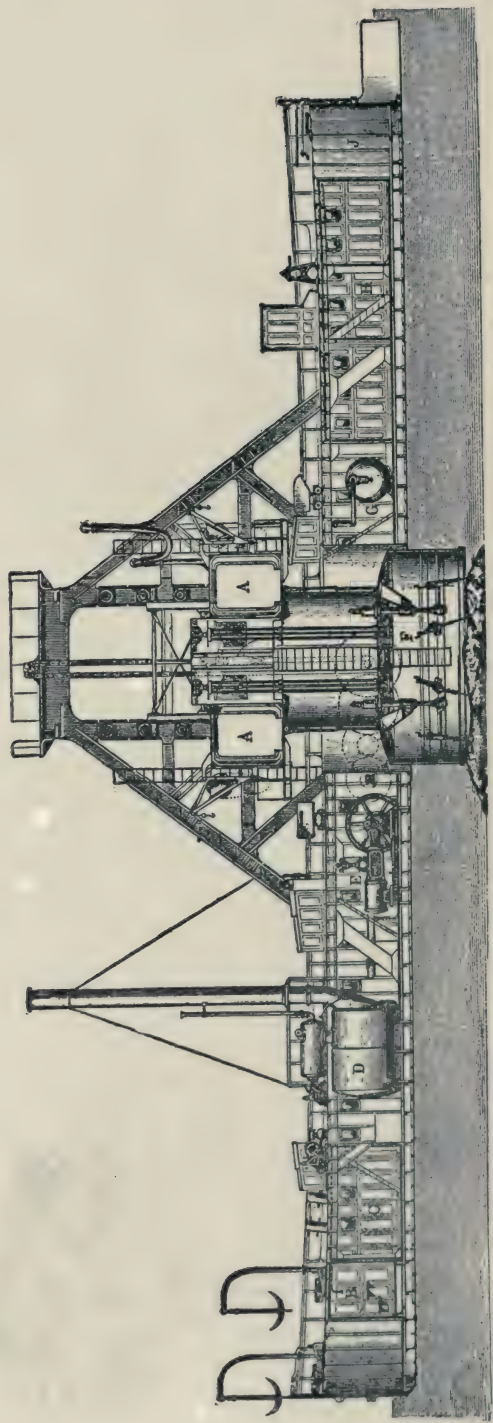

FIG. 9.—Boat with Submerged Caisson for the Excavation of Rock under the Rhine River.

per cylinder of smaller diameter than the drill hole but of sufficient length to admit the entire cartridge. At the upper end is attached a piece of iron gas pipe long enough to extend well above the surface of the water. The copper cylinder is slotted on one side throughout its length to permit the insertion of the cartridge, with its exploding wires fastened to the upper end. When the cartridge with its wires has been passed into the cylinder, the latter is inserted in the drill hole, and a long pole is passed down through the gas pipe forming the extension of the cylinder. The whole pipe is then withdrawn, the pole being used to prevent the cartridge from coming with the cylinder. As soon as the charging apparatus has been entirely removed, the cartridge is exploded.

Costs. Concerning the cost of excavation of rock under water by blasting, Mr. T. Jenkins Hains, while in charge of the New York office of the Nicaragua Canal Commission, collected valuable data from the report of the Chief Engineer of the U. S. Army concerning the cost of dredging rock in the year 1897, in different parts of the country. He gives the following examples of the cost of rock excavation under water:

Coheco River, N. H.	ledge 1300 cu.yds.	7 ft. deep	\$7.50 cu.yd
Bronx River, N. Y.	" 1300 "	6 "	6.89 "
Sullivan Falls.	" not stated	10 "	16.48 "
Kennebec River.	" 1300 cu.yds.	10 "	9.87 "
Sassanoa River.	" 800 "	not stated	10.48 "
Moosabu, Me.	" 890 "	" "	13.75 "
Boston Harbor.	" 8772 "	27 "	16.48 "

From these examples it can be deduced that, broadly speaking, the cost of rock excavation under water is directly proportional to the depth of the ledge and inversely proportional to the quantity. But a more correct idea of the cost of removing subaqueous rocks by blasting and dredging can be obtained from the following examples taken from Engineering News, Vol. LVI. These show the results obtained by two different contractors in removing ledges of calcareous rocks, in deepening the channel of the Detroit River, the contractors working on two different sections.

The contractors for Section 2, Messrs. G. H. Breyman & Bro. of Toledo, O., agreed to excavate the rock at the following prices: \$3.25 per cu.yd. bank measurement, for all the material above the 22-ft. grade, and \$1.625 per cu.yd. for all material removed between the 22- and 24-ft. grades. The contractor's plant consisted

of 2 dredges, 2 drill boats, one with 4 drills and the other with 2 drills; 1 derrick scow with diving outfit, 2 tugs and the necessary dump scows. Over an area of about 39,000 sq.yds. the material was broken up by drilling and blasting. The holes were generally drilled at the corners of 5-ft. squares. The number of holes drilled was 17,212, these being 165,011 lin.ft., showing an average depth of 9.6 ft. per hole. There were removed from an area of 23,000 sq. yds. 33,226 cu.yds. of material, making an average depth of 4.2 ft. This demonstrates that the holes must be drilled to a depth over twice that of the material to be removed. The total hours worked by the drill boats for all drills was 18,358. This is at the rate of 9 ft. per hour—a remarkably good showing. Of the 33,226 cu.yds. of material removed 13,003 cu.yds. were of full-rate material, being above the 22-ft. grade; 17,578 cu.yds. of half-rate material, being between 22- and 24-ft. grades, and 2645 cu.yds. of material for which no payment was made, being below the 24-ft. grade.

The work on Section 4 was performed by Mr. M. Sullivan of Detroit, Mich., at the contract prices of \$2.40 per cu.yd. bank measurement, for material above the 22-ft. grade, and \$1.20 per cu.yd. for material between 22- and 24-ft. grades. The contractor's plant was composed of 4 dredges, 4 drill boats, two with 2 drills and two with 3 drills; 1 derrick scow with diving outfit, 3 tugs and the necessary dump scows. Over an area of about 120,000 sq.yds. the material was broken up by drilling and blasting. The number of holes drilled was 36,479, there being 260,313 lin.ft., showing an average depth of 7.1 ft. per hole. There were used 328,444 lbs. of dynamite, or 9 lbs. per hole, a little over $1\frac{1}{2}$ lbs. for each foot hole. There were removed from an area of 225,000 sq.yds. 222,635 cu.yds. of material, which would give an average depth of nearly 3 ft. The holes in this case also were over twice the depth of the removed material. The total hours worked by the drill boats for all drills was 34,729. This is at the rate of 7.5 ft. per hour, or considerably less than on Section 2. Of the 222,635 cu.yds. of rock excavated 78,260 cu.yds. were of full-rate material, being above 22-ft. grade; 100,893 cu.yds. of half rate material, being between 22- and 24-ft. grades, and for 43,682 cu.yds. no payment was made, being below the 24-ft. grade.

Of the total amount of the rock excavated the following shows the percentage of work done as compared with the compensation:

	Section 2	Section 4
Full rate.....	39%	35%
Half rate.....	53	45
Not paid.....	8	20

It would seem from this that some other plan or method might have greatly reduced the amount of work done for half pay or for which no compensation was made, but it is difficult to decide upon this without experimenting.

COMPARISON OF THE TWO METHODS.

A comparative test of the two methods of breaking subaqueous rocks was made at Blyth, England, and reported upon by Mr. John Watt Sandeman in Engineering, June 28, 1907.

In the improvement proposed at Blyth it is necessary to remove 500,000 cu.yds. of sandstone rock and shale, and the work is now being done by means of 2 Lobnitz rockbreakers and 2 700-ton hopper dredges (of the clamshell type). Previous to 1906 about 150,000 cu.yds. of rock were broken up by means of drilling and blasting, so that a comparison of the two methods can be made.

The rock at Blyth is the sandstone of the Coal Measures, varying in character from friable stone containing fire clay, shale and coal, to sandstone equal in hardness to basalt.

Rock Drilling and Blasting. The drilling and blasting of the rock was carried out by means of a barge having 6 drills, which were lifted by steam power and guided by hand.

The distance between the shot holes was 5 ft. in one direction and 6 ft. 2 in. in the other. The blasting material, bellite, was lowered in canisters through the drilling tubes, and fired by fuses and detonators, the holes being tamped with small gravel.

The average quantity of rock drilled and blasted per week by means of one barge was 488 cu.yds., and the average cost of drilling and blasting was about 3s. per cu.yd.

The quantity of rock blasted was ascertained by the number of holes and their depth, which was 1 ft. more than that to which the rock could be dredged, and a check was made by sounding over an area of rock before blasting and after dredging.

Rockbreaking. Each rockbreaker employed at Blyth consists of a steel barge carrying shear-legs, from which is suspended a steel ram of 15 tons weight, 40 ft. to 50 ft. in length, and 17 in. to 19 in. in diameter, having a renewable conical point, tempered so as to

combine a hard center with a softer exterior, which, while wearing, enables a sharp point to be preserved.

The ram is lifted by a wire rope wound upon a loose drum, driven by a friction-clutch. It is allowed to fall from a height of 8 ft., and on an average of eight to nine blows penetrates the rock to a depth of 3 ft. which is sufficient to allow of its being dredged to a depth of 2 ft. 6 in. The machine is arranged so that it can be moved on end and athwart simultaneously by chains worked by steam winches. By means of sighting rods on board and ashore the barge can be moved over uniform distances. The ram was at first worked in positions 3 ft. apart and this distance was gradually increased to 4 ft. 6 in., which was found to be close enough for either hard or soft rock.

The average quantity of rock which one machine has broken is per week, working night and day, and allowing for all stoppages, 908 cu.yds. at a cost of 8.8*d.* per cu.yd. This is based on six months' working; but as it is necessary to allow for renewal of rams, the following is the actual cost per week of wages, coal stores and water, and the estimated cost of repairs, full allowance being made for renewal of rams and all contingencies:

	£	s	d
Wages.....	16	1	6
Coal, stores, and water.....	6	10	7
Estimated cost of repairs, renewal of rams, ropes, etc.	22	0	0
Insurance at 30s. per cent = £102 per annum.....	1	19	2
	—	—	—
908 cu.yds. at 12.3 <i>d.</i>	46	11	3

The cost of one rockbreaker is about £6800 and if 4 per cent be allowed for interest and 2½ per cent for depreciation (the machine being well maintained) the additional cost per cubic yard would be 2.2*d.* making a total cost of about 14.5*d.* per cu.yd.

The quantity of rock broken is ascertained by the number and depths of the penetrations of the ram in a given time, which are carefully recorded and after dredging the amount of rock removed is checked by soundings.

Rock Dredging. Each of the hopper dredges has two sets of buckets, one for rock dredging and the other for sand, clay or gravel, having 50 per cent greater capacity. The bucket lips are of cast-steel and the pins and bushes of manganese steel. The lips of the buckets for rock dredging are set at an angle of about 27 degrees

to the bucket-backs, and those for sand, etc., at an angle of 55 degrees.

Rock picks were tried between the buckets of one of the stationary dredges, but as they did not assist in removing rock they were not employed in the hopper dredges. When in rock the dredges advance by 6-ft. lengths, and dredge athwart for breadths up to 200 ft. The rock is loaded into hoppers and deposited at sea, or (when required for harbor purposes) into separate barges having gridded hoppers, enabling the rock to be screened and discharged.

In estimating the quantity of rock carried in the hoppers of the dredges deduction has been made for water contained along with the rock.

As compared with blasting, the rockbreaker disintegrates and breaks the rock into smaller pieces, so that the quantity lifted by the dredges in a given time is about 15 per cent more than that of blasted rock.

The average quantity of blasted rock removed by one dredge per day of 24 hours, and allowing for all stoppages, is 158 cu.yds., and of that broken by the rockbreaker 182 cu.yds. The average number of days per annum worked by the dredges is 227. The cost per cu.yd. for dredging blasted rock is 2s. 6d. The cost per cu.yd. of dredging rock broken by rockcutter is 2s. 2d.

Allowing 4 per cent for interest, and 2½ per cent for depreciation on £19,000, the cost of a dredge, the additional cost per cu.yd. would be 8.2d. for blasted rock and 7.1d. for rock broken by rockbreaker.

Comparative Costs. The comparative cost of rock removal under the two systems is as follows:

	PER CU. YD.	
	s.	d.
Drilling and blasting rock	3	0
Dredging same, 2s. 6d. + 8.2d.	3	2.2
	—	—
	6	2.2
Breaking rock by rockbreaker	1	2.5
Dredging same, 2s. 2d. + 7.1d.	2	9.1
	—	—
	3	11.6

Difference in cost per cu.yd. in favor of the removal of rock by means of rockbreaker is 2s. 2.6d.

CHAPTER VI

EXCAVATION OF SUBAQUEOUS ROCKS—BY A LARGE BLAST

THE removal of subaqueous rocks by a single huge blast can be accomplished in two different ways—either by honeycombing the whole reef and firing the charges simultaneously, or by a cofferdam and series of lift holes.

Mining or Honeycombing the Reef. This method was employed by Gen. Newton in blasting the Flood Rock at Hell Gate, in New York Harbor, and was described by 1st Lieut. George Mc.C. Derby, Corps of Engineers, U. S. A., in the Sanitary Engineer, December, 1885. The following description is slightly condensed from his paper:

All the vessels plying between New York and Long Island Sound go through Hell Gate, a narrow and crooked waterway between the rocks, where the East River makes its way between Blackwell's Island and Ward's Island. Since the year 1848 it was estimated that one vessel in every fifty attempting the passage was more or less damaged by being thrown on the rocks. The channel was so dammed by these obstructions, as to show a difference of level of 1.9 ft. at high water, causing currents of $8\frac{1}{2}$ knots an hour. The necessity of removing these obstructions was felt for many years, and Congress appropriated money at different times. Such sums, however, were inadequate for the purpose. When Gen. John Newton, Corps of Engineers, U. S. A., was placed in charge of this improvement, he vigorously presented the real solution of the problem. Gen. Newton proposed to remove all the dangerous reefs to a depth of 26 ft. at mean low water and submitted detailed estimates of the cost of the work and the time required to complete it. This project, on account of its magnitude, was first only partially approved, but after the successful demolition at Hallett's Point, Astoria, L. I., it was adopted in its entirety.

The method adopted by Gen. Newton at Flood Rock was as follows: Two shafts were sunk on the ridge of the reef and from

these shafts two sets of parallel galleries were run at right angles to each other, undermining the whole nine acres of reef and leaving it standing on pillars about 15 ft. square and about 25 ft. center to center. The roof in the cross galleries was then blasted down, leaving it as thin as the character of the rock and the location under the river bed would permit. The average thickness of the roof was 18.8 ft., while the least thickness was 10 ft. As the soundings, although taken with great care, could hardly indicate the difference between rock conglomerates and boulders, the cutting of the roof of the small galleries was carried on with great caution. Only one drill hole was fired at a time, thus requiring a large expenditure for both drilling and explosives; 2.3 pounds of explosives and 11.97

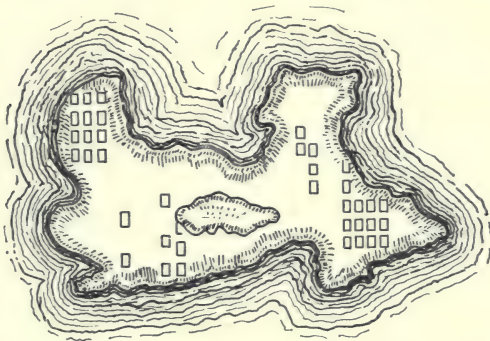

FIG. 10.—Plan of Flood Rock at Hell Gate, N. Y.

ft. of drilling were required per cu.yd. The height of the galleries varied from 4 to 33 ft., while they were 10 ft. wide. Fig. 10 shows the honeycombing of the Flood Rock. The rock was fissured and an inrush of water was only prevented by walling the seams with Portland cement. The seams gave continuous trouble until the work was completed. The amount of work required to undermine the reef consisted of 21,669 ft. of tunnels driven, 80,232 cu.yds. of rock excavated, and about 480,000 lbs. of high explosives consumed. Only one man was killed during the operations.

It was the intention of Gen. Newton to excavate a cavity sufficiently large to receive the débris from the roof and leave a depth of 26 ft. at mean low water, after the final blast. But on account of the extra expense of timbering and the fact that it required 1.45 cu.yds. of space to contain one cu.yd. of roof after it was broken,

this part of the project was modified, as it was believed that the required depth could be obtained more economically by dredging a portion of the débris.

After the completion of the galleries, the roof and the pillars were drilled to a depth of 33 ft. below mean low water, with holes enough to contain 0.79 of a pound of No. 1 dynamite for every cu.yd. of rock and every 7000 pounds of water overhead, amounting to 1.04 pounds per cu.yd. of rock broken. The holes drilled upward were at angles of 60 and 45 degrees, the former, along the center of the gallery (see Fig. 11), were 8 ft. deep, the latter 10 ft., so as to reach as far over the pillars as possible. These lengths, however, were often reduced by the drill cutting into seams open to the river.

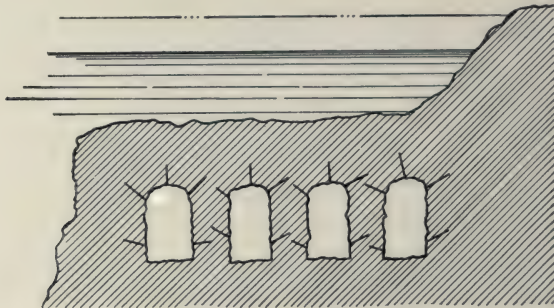

FIG. 11.—Honeycombing of Flood Rock, showing the Direction of Drill Holes in Galleries.

The holes were of such a diameter as to receive a rigid $2\frac{1}{4}$ -inch cartridge throughout their entire length, and altogether 113,102 ft. of such holes were required.

An elaborate set of experiments was planned and carried out in order to obtain more simple methods of firing the mine and to extend the list of available explosives, which was then practically limited to dynamite or other nitroglycerine compounds. These experiments resulted in proving that all the electrical connections between the drill holes and the battery could be dispensed with, as the explosion of a few pounds' charge of dynamite would fire with absolute certainty under water another charge of dynamite packed in a thin elastic envelope at a distance of 27 ft. They also proved the efficacy of firing long narrow charges of rackrock, an explosive so inert and so safe to handle that a pistol bullet may be shot into

it at short range with impunity. This explosive was afterward adopted for the great blast, its strength under water being somewhat greater than that of No. 1 dynamite. It cost a little more than half of No. 1 dynamite and had the great advantage that it could be stored in large quantities without danger to the city, as it was made explosible just before being taken to the mine.

The rackrock, consisting of 79 parts of finely ground chlorate of potash and 21 parts of di-nitrobenzole, was mixed in small batches in a leaden trough and packed at once into cartridge cases $2\frac{1}{2}$ in. in diameter and 24 in. long, made of copper 0.005 of an inch thick. Into each cartridge was inserted a small exploder containing 30 grains of fulminate, reinforced by one ounce of dynamite. The cartridge, being loaded its lid was securely soldered, using an alloy melting at 160° F. and a hollow soldering iron heated by blowing through it a jet of wet steam. In all 42,528 cartridges were thus soldered without accident.

All the loading in the mines was done by a gang of 12 men, who first placed the rackrock cartridges, ending with one of dynamite containing the fulminate exploder, besides the usual brass wires, which were secured by means of wooden wedges. The number of pounds of rackrock put in drill holes was 240,399; of dynamite, 4331; total, 284,730 pounds of explosives. There were 11,789 drill holes in the roof and 772 in the pillars. To prevent the cartridges from slipping out of the inclined holes the exterior of the cartridges was provided with short brass wires spreading out.

The primary charges which were to fire those in the drill holes were placed along the galleries at intervals of 25 ft. They consisted of two $24 \times 1\frac{1}{4}$ -inch thin copper cartridges filled with No. 1 dynamite, packed solidly and lashed upon a horizontal beam at a height above the floor varying from 3 to 12 ft. according to the height of the galleries. On top of these was lashed a rigid brass shell 8–12 in., containing about one-half pound of dynamite put in loose and a platinum wire connected by wires with the battery at the head of the shaft. There were 591 of these primary charges arranged in 21 circuits of 25 each, and three circuits of 22 all coming together at the poles of the batteries. Some of these circuits were nearly one mile long.

The battery was composed of 60 cells all coupled in one series, two large mercury cups constituting the poles. The 24 lead wires dipped into one of these cups and the 24 return wires terminated

in a third. Between this third cup and the remaining pole of the battery stood the circuit closer, composed of an iron cup containing mercury in which sat a thin glass tumbler partially filled with mercury. The leading wires were connected with the mercury in the iron cup while the returning wires were connected with the mercury of the tumbler. To close the circuit it was only necessary to break the glass tumbler. An iron rod $\frac{1}{4}$ in. in diameter and 4 ft. long terminated with a disk, was used for this purpose.

When all the work was completed the mine was flooded and the blast was fired at 11.13 A.M., October 11, 1885. The explosion occurred over the whole area of the reef. There was no loud report and no dangerous shock through the earth, though a slight vibration was observed as far away as Cambridge, Mass. A few panes of glass were broken in the neighborhood, a number of loose ceilings came down and several bricks were shaken from a chimney of a house near the water's edge in Astoria. This was all the damage done. Soon after the explosion a diver was put down and found the rock was cracked and shattered; the surface blocks very large, but in good shape to be dredged with reasonable amount of surface blasting. Immediately two grapple dredges were set to work and they removed 120 tons per day.

The total cost of the work was estimated at \$2.99 per cu.yd. of rock broken.

Lift Holes. The method of removing the subaqueous rock by a large single blast resulting from the simultaneous firing of long lift holes driven from a pit inclosed by a coffer-dam was recently employed at Henderson's Point at the Portsmouth Navy Yard in New Hampshire, an account of which was published in the Engineering News, August 3, 1905; from which the following description is taken:

Henderson's Point was a ledge of trap rock 400 ft. wide at the base and projecting 300 ft. into Portsmouth Harbor in such a manner as to make it extremely difficult for large war vessels to reach the new drydock. The area of rock to be excavated below low water was about three acres, and the contractors decided to build a coffer-dam, horseshoe shape, and excavate all the rock possible within this coffer-dam by ordinary methods. By doing this a rim of rock was left under the coffer-dam and extending out beyond it into the harbor. This rim of rock contained approximately 35,000 cu.yds. which was broken up by a single large blast. Figs. 12 and 13.

The contractors decided to undermine the coffer-dam by drilling long lift holes, using the large Ingersoll-Sergeant, H₉ submarine drills mounted on timbers laid in the bottom of the pit excavated inside the coffer-dam. In this way 203 lift holes, having a dip of 1 in 10 from the horizontal, were drilled 50 to 79 ft. deep and 5 ft.

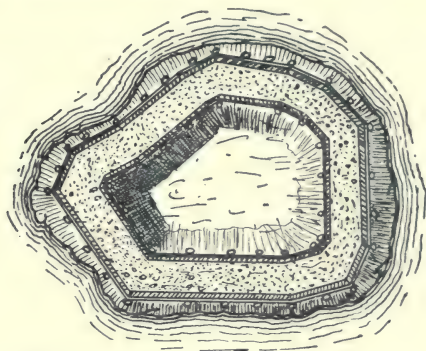

FIG. 12.—Plan of the Ledge of Rock at Henderson's Point.

apart, all around inside of the pit. The holes started 5 ft. below the bottom of the grade to which dredging must be carried, so as to make sure of leaving no *hog backs* after blasting. Fig. 13.

The diameter of the holes at the collar was 6 in. and the deepest

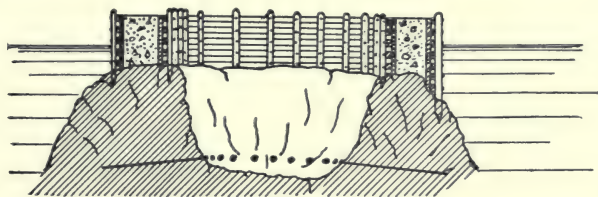

FIG. 13.—Method of Excavation followed at Henderson's Point.

holes were 2 in. in diameter at the bottom. A cross bit was used for starting a hole, but plain chisel bits were found very effective for the greater depths. The rock was exceedingly seamy, many hard quartz veins occurring at frequent intervals in some holes.

The average progress of drilling was 30 ft. per 10-hour shift,

but in very seamy soil this quantity was greatly reduced, being at times not more than 10 ft. per 10-hour shift. Eight Ingersoll-Sergeant and two Sullivan drills having $5\frac{1}{2}$ in. cylinders were used for this work. Each drill was mounted on wooden blocking bolted to two lines of sills bedded in the bottom of the pit. An extension clinch was used to facilitate the handling of the drill steel, by giving plenty of clearance between the drill and the face of the rock ledge.

The long lift holes were charged with dynamite. At first the sticks of dynamite were inclosed in tin tubes, but owing to the tendency of these tin tubes to catch on irregularities in the sides of the hole it was decided to use only plain paraffined paper cartridges. These dynamite sticks were 24 to 30 in. long and made in four sizes to fit the taper of the drill hole, $2\frac{1}{2}$, 3, $3\frac{1}{2}$ and 4 in. in diameter. About 38 tons of dynamite was used for charging 203 lift holes, and it was furnished by the National Powder Co. of New York. Nearly half of the quantity had 60 per cent of nitroglycerine and the balance 75 per cent. Since it was expected that some of the dynamite would be under water three weeks before the firing of the blast, the manufacturers wrapped each stick with two layers of paraffin paper and afterward coated the sticks with a paraffin composition.

Nine hundred electric exploders were used, especially constructed for subaqueous work by the Star Electric Fuse Works of Wilkes-Barre, Pa. To fire the exploders there were used 110 volts and 75 amperes, the 900 exploders being divided into 45 groups of 20 each. The 20 exploders were joined together in series. Each of these 45 groups was joined parallel to the main wires. By this method of wiring every exploder received $1\frac{1}{2}$ amperes.

The firing station was located 1000 ft. away from the nearest point of the coffer-dam, in which a breach was made at low tide, in order to flood the pit and thus secure a water tamping, as well as cushion to take up the shock of the explosion. Even at high tide there were a few parts of the rock ledge visible. The blast was fired at 4.10 P.M. Sections of the coffer-dam fell in the water at a distance that appeared to be nearly 800 ft. away from their original position. A huge column of water, timber and rock rose to a height of perhaps 150 ft. and at the same time a sort of *tidal wave* rushed across the narrow 800-ft. channel to a height of several feet. The shock was scarcely felt by those at any considerable distance, for the explosive appeared to have expended nearly all

its energy in breaking rock. Not a single accident marred the enterprise and the office building 300 ft. away from the blast was uninjured.

The work was carried out by the Massachusetts Contracting Co. of Worcester, Mass., with Mr. O. A. Foster as superintendent in charge, while Lieut. Luther E. Gregory, U. S. N., was the engineer in charge for the government.

CHAPTER VII

HINTS ON SELECTING DREDGES FOR VARIOUS WORK

NOTHING is more important than the selection of the style and size of a dredge to be used on a job. Thousands of dollars have been wasted by errors in judgment made in this regard, or from ignorance on the subject. Only a few years ago the writer saw a mistake made of this kind that proved expensive to all concerned. It is almost impossible for a novice to decide knowingly in such a matter. Not only must one be conversant with the various styles or type of dredges made and used, but the work they will do and their general adaptability must be known. Even then it is not always possible to select a dredge suitable from those already in use, but it is frequently necessary to design a special machine, to do the proposed work in an economical manner.

At times, though, only some detail of the dredge has to be changed to adapt it to the work. In America, both engineers and contractor make the serious blunder of attempting to use a dredge already at hand, instead of rebuilding it, or getting another machine, believing that either by their determination or by their ingenuity they can make the machine in question do the dredging economically.

Although it is true that many dredges of special design are copied in part from older types, yet no one but those of experience in dredge building and operation should attempt to design machines. There are some monumental piles of junk in existence due to poor designing, and in some cases profits are quickly eaten up in repairs due to the same reason. Dredges must not only be designed well, but must also be well constructed.

There are three important considerations that should be given the selection of a dredge: First, the character of the soil or material to be excavated. Second, the method to be used in the disposal of the material and the distance from the point of dredging to the place of deposit. Third, the local conditions that may surround the work, such as whether harbor or river improvement, the traffic

that may interfere with the dredges, whether it is dredging to reclaim land, or to deepening channels, and many other considerations of this character. One important item is the depth of the water and the probable chance of storms.

The character of the soil has much to do with the general type of dredge to be selected, as whether a hydraulic dredge, a ladder or dipper type is to be used.

The suction or hydraulic dredge is better suited to work in soil or material that is homogeneous, mattering but little whether it is soft or compact, but it should not be excessively hard. Such materials are sand, clay, earth, gravel and alluvial deposit, that are free from large obstructions as boulders, snags, stumps and such things that are not readily broken up with the cutter or agitator.

When the material or soil is very compact and contains much large gravel or small boulders, or is tough hardpan, ladder dredges are better adapted than the suction dredge. Extremely large boulders cannot enter the buckets so the ladder dredge must excavate around them, leaving them to be taken out by other means.

Grapple dredges will work in either hard material or in soft soil, but more efficient work is done when the material is homogeneous.

When the material is full of obstruction, whether the great mass is soft or compact the dipper dredge is the most efficient machine in use.

When the material is such that it can be pumped through pipes to the place of disposal, the suction dredge is ideal, unless the line of discharge pipe interferes with the traffic. If the distance to transport the dredged material is very short, a high tower ladder dredge with a long chute can be used, but generally speaking when a ladder dredge is used scows or barges are necessary to transport the excavated material. For both the grapple and dipper dredge scows are necessary unless the dredged material is deposited behind a nearby bulkhead or is carried away by a system of belt conveyors.

When the water is rough at the site of dredging, or if the scows or pipe line interfere with the traffic of vessels, then the self-containing or hopper type of dredge should be used. The hydraulic hopper dredge and the ladder hopper dredge as well as the combination dredge are all described in this treatise.

As a rule hopper dredges are sea-going vessels. In ordinary weather they can work without anchorage. The dredge passes slowly over the area to be dredged, picking up its load, and when the hoppers

are full lifts its suction pipe or its ladder and proceeds to sea to dump its load. This style of dredge is not well adapted for material or soil that does not settle or precipitate in the hoppers.

When scows or barges are used the ladder dredge is well adapted, especially for hardpan or similar material. In Europe this machine is used on all kinds of work both wet and dry. It was used exclusively on the Suez Canal and also on some of the European canals, and in open channels, when large quantities of earth have to be excavated over large areas it is well adapted, as it gives a true and level bottom. This type of machine is not easily affected by tides or currents, and although it will excavate more cubic yards per horse power than any other type, yet for working in confined places, and under trying circumstances, and for power, speed and general adaptability it will not compare with the dipper dredge so generally used in America.

A great advantage of the dipper type is in economy of labor. It is able to handle boulders, stumps and other obstructions, owing to its great strength and power, and to the fact that it is held to its work by means of powerful spuds. This machine has a great range of adaptability, as it will dig at depths of 40 ft. or more, load scows or cast material upon the bank.

This dredge, as well as the grapple or clamshell dredge, depends upon the operator for its speed. Everything being equal, a skilled operator will excavate more material than a less experienced man. Thus it is important that the operator's work be made as easy as possible and all levers should be located conveniently and be easily controlled. Grapple dredges cannot excavate as hard material as a dipper machine, but they can work at a greater depth. Spuds and anchors are used to hold the dredge in place in the same manner as with a dipper machine.

Hydraulic dredges are especially adapted to excavate homogeneous material in large quantities, when the pipe line is not over 3000 ft. long. With a greater length of pipe a large per cent of the power is absorbed by friction in the pipes. Clay material shows less wear on the pipe than sand, and a larger per cent of solid material is carried when clay is excavated. The most important point is the cutter or agitator. The simplest agitator is a bird-cage affair used on small dredges for sand. Revolving first in one direction and then in the other the sand is stirred up enough to become mixed with water and the suction from the pump lifts the sand and water. As fast as a hole is made in the sand, the mass of sand keeps caving

in, thus feeding the sand to the pump. For harder material the agitator is equipped with knives, which cuts the material as they revolve. For stiff and heavy clay and harder material sufficient space must be left between the blades for large lumps of clay and small boulders to enter the suction pipe. The cutter must not only be of great strength, but must be so attached to the suction pipe as not to be easily detached by the great strain that comes upon it.

Neither the hydraulic dredge nor ladder type can handle anything

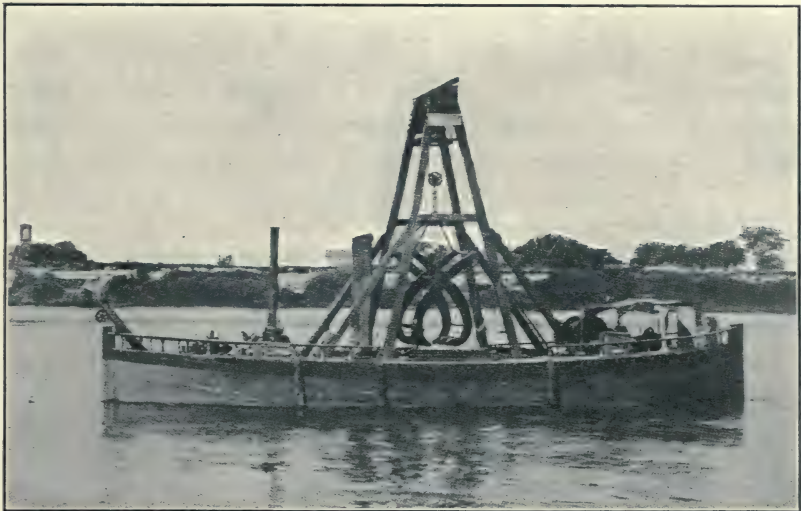

FIG. 14.—Stone Lifter on St. Lawrence River.

in the way of rock except small boulders. The limit is smaller with the hydraulic dredge than with the endless chain or ladder dredge. A dipper dredge can handle rock and boulders of several yards in size, and the grapple dredge can also handle rock and boulders when fitted with a special stone grapple. But with any type of dredge large stones or boulders must be broken up before they can be removed by dredges. At some places there are now used stone scows or lifters. Fig. 14 is an illustration of such a machine used by the Canadian Government on the St. Lawrence River. This stone lifter, by means of its stone hooks or grabs, will raise boulders weighing as much as 50 tons.

Hydraulic and ladder dredges can by cutting up snags, logs, stumps and such obstructions remove them, but they are ill suited for such work. The dredge that will remove these better than any other is the dipper machine. The great pull of the hoisting engines on the dipper, when it catches under a snag or log will raise it up even when covered with a foot or two of soil. In excavating the shallow canals through the Dismal Swamp in Virginia and North Carolina, great numbers of logs and stumps were encountered and dipper dredges were used exclusively on this work. However, owing to the excessive number of sunken logs encountered, the work proved very expensive, and some of the contractors lost money, due to this cause. On the Mississippi River snag-pulling machines are used for removing old snags and logs, making it possible for hydraulic dredges to follow up these machines.

For some jobs not only must special dredges be designed, as previously stated, but it is sometimes necessary to design special pipe lines, scows or even hoppers, in order to carry on the work economically.

It is almost impossible to give any rule for selecting a dredge for canal, channels in large bodies of water, for rivers, harbors and other improvements. The soil, the disposal of the material and local conditions must govern it. All of the types of machines here listed are and can be used. Sometimes on one job in America hydraulic, ladder and dipper dredges have been used. Some have also been of the hopper type, and some were self-propelling, while others were non-propelling.

In narrow canals dipper dredges are often used, depositing the material on either bank. In wide streams scows are used to take the spoil both from dipper and grapple dredges. For rivers and harbors and for channels in bays and lakes all styles of machines are used. For filling in behind bulkheads and for reclaiming low lands the hydraulic dredge is a favorite machine, as the great quantity of water distributes the material over a large area. When bulkheads are not built, dipper machines are first used to throw up a dike or levee and then a hydraulic machine for depositing the material behind the dyke.

Often dredged material has to be handled twice. It may be first loaded onto scows, then dumped, and handled again to be placed behind bulkheads, walls, or into piers. This rehandling is sometimes done with suction dredges or by bucket machines. At times hopper

scows are used and the material pumped directly from the scows. As a rule the second handling generally costs more than the first.

When dredges work in sheltered harbors or in rivers and canals it is not necessary to have them self-propelling, but when they are used in exposed places or go to sea it is safer to have a self-propelling machine. Many large dredges are self-propelling even when designed for river work, as it is more economical to move them great distances without the aid of tugs and it is easier to maneuver them while at work.

Non-propelling dredges are handled when at work by means of spuds and by anchor lines. For small dredges the lines are handled by small rowboats and capstans on the deck of the dredge, but for large machines anchor scows are sometimes used. These are small scows with a windlass and capstan on it to handle the heavy anchors, and the lines are run from the scows to the dredge.

When anchor lines are used the maneuvering of the dredge while at work must always be planned so as not to interfere with the passing of vessels. The work should be done so that delays happen neither to the dredge nor to the vessels.

CHAPTER VIII

DREDGING CREWS, THEIR QUARTERS, AND TENDERS FOR DREDGES

THE size of a crew needed to operate a dredge varies exceedingly, according to the type and size of the dredge. The wages of men likewise vary in different sections of the world. Generally speaking most dredgemen, especially when they live on board the boat, are paid monthly salaries. However, some are paid wages by the day. As dredges are used to a great extent on government work, the working hours of a shift, especially in America are, as a rule, 8 hours. Thus to work continuously night and day, three crews are needed.

In the United States the Federal Courts have decided that dredgemen are seamen, so that laws affecting seamen apply to dredgemen.

When dredges are worked in fleets or more than one is engaged on a single improvement a superintendent or general manager is in charge of all the machines. Under him is a captain for each dredge, under whom on large machines are several officers as assistants, who are in charge of the different shifts. Then there are employed engineers and assistant engineers, and a chief fireman and assistants. In some sections operators known as levermen are employed, and on large dredges there are always several oilers or greasers; otherwise the machinery is not kept well lubricated.

There are also employed laborers, known as deckhands, linesmen or sailors. These men do the general work and attend to the lines, anchors, spuds, pipe lines and other details. Scow men are also employed, being used either on the anchor scows when used or on the scows that carry away the dredged material.

On the largest dredges and those of the sea-going type, carpenters, machinists and blacksmiths are frequently employed. There are also watchmen and cooks employed. In addition to all of these the tugboats have their necessary crews.

Some small hydraulic dredges used for loading scows with sand

for commercial purposes are worked with a crew of only 2 or 3 men. Small grapple and dipper dredges use less than 10 men. The Canadian Government has worked one dipper dredge for a number of years with a crew of 9. A snag boat also worked by the same government is manned with a crew of 9. The hydraulic dredge "King Edward" carries a crew of 18 men, while the large hydraulic dredge, "J. Israel Tarte," used in St. Peter's Bay on the St. Lawrence River, has a crew of 35 for night and day work. The elevator or ladder dredges used on the same river carry crews of 28 to do continuous work throughout the 24 hours.

The American sea-going hydraulic dredges "Atlantic" and "Manhattan", used in the Ambrose Channel in New York Bay, each carries a crew of 54 men for night and day work.

For gold, tin and platinum dredging the crews are much smaller. Hydraulic dredges for such purposes are not extensively used, the ladder type being preferred. Mr. Henry G. Granger advocates the use of a specially designed suction dredge for gold mining and gives a crew of 6 men to manage the dredge with 13 men under these in each shift. Then for these 8-hour shifts 39 men will be needed besides the 6, making 45 men in all. In charge of this crew he has a general manager experienced in gold saving. The others are captain, engineer and assistants, firemen and assistants, levermen, deckhands, cook and general helpers.

In the Oroville district in California the large electrical dredges excavating from 100,000 to 200,000 cu.yds. per month are operated with small crews. Over each machine is a dredgemaster, and he has 6 men under him, 2 for each shift. Besides these some dredges use a man on the ground known as the shoreman.

When crews are worked in or near large cities, quarters are not needed for the men on the dredges, but for night and day work or for dredges at sea or for work away from their home ports; ample quarters for the men should be provided on the boat. Occasionally, as on the St. Lawrence River, such quarters are built on scows which are anchored near the dredge. When the crew's quarters are built on the dredge they are generally on the upper deck above the machinery. They should be sanitary and comfortable and the men should have a good mess room in which to eat their meals. The food furnished should be substantial, of a pleasing variety and well cooked and served. When men are well fed and given comfortable quarters and beds they in return give efficient service. The quarters can

be heated by steam from the boilers, and lighted by electricity. There should also be a room furnished to dry the men's clothing and shoes. Men never give good work in clothing that is only half dry. Electric lights are an essential for night work, and at only a slight cost the entire dredge can be furnished with both incandescent and arc lights. An electric search light is found to be a great aid in dredging, as anchor scows and lines can be watched and adjusted by its aid.

Ample provision should also be made for men to wash and bathe. When coal and supplies are taken on the dredge the helpers get very dirty, and a bath when they are through work will improve their health.

The coal bunkers on a dredge should be so situated that the coal can be fed under the boilers without great labor, and so the bunkers can be refilled from scows with ease, or if the dredge goes to a dock for the coal, so it can be placed aboard without any trouble.

On some of the largest dredges, especially those that are out from port for some days, some space is devoted to a repair and blacksmith shop. This frequently means the saving of much valuable time and money. Where a number of dredges are working close to each other a scow is sometimes fitted up as a repair shop and towed from dredge to dredge as needed.

Many large dredges go to their working places on Monday and remain there excavating until Saturday evening, when they return to their docks. Dredging is not done on Sunday, but new supplies are placed aboard and needed repairs are made. Such dredges are generally self-propelling. Non-propelling dredges, as a rule, remain anchored at the site of their work over Sunday.

A record or log should always be kept of the movements of a dredge, as well as of the time spent in dredging and the delays that occur and their causes and such details as are found essential. Such records are generally found to be useful, both in keeping costs of work done and as a check on the crews.

Every dredge must have a number of tenders in order to aid in its work. This is even so with sea-going hopper dredges.

There must be tugboats of great power and entirely seaworthy, also scows to haul the dredge material and supplies as coal, provisions, etc. Then snagboats and stonelifers are often needed, and drilling boats for drilling rock to be excavated. Rockbreakers too are now added to dredging fleets. When hydraulic dredges are

used a large number of pontoons are necessary to carry the discharge pipe. Pontoons or scows are also used to carry belt conveyors when the latter are used to transport the dredged material.

Launches are necessary for superintendents and engineers to visit the dredges and oversee the work. The use of such launches often means the saving of much time and money. Every dredge should be equipped with one or more rowboats for the sailors or dredgemen to attend to the anchors and do other work in them. Such boats should be flat-bottomed, so that the men can work in them without overturning, as frequently happens with round-bottom boats. These boats should be heavy, yet not too heavy for one man to row in an ordinary sea. They should be arranged for both rowing and sculling.

CHAPTER IX

CLASSIFICATION AND CAPACITIES OF DREDGES

THERE is such a large variety of dredging machines on the market that it is not very easy to give a clear classification of them. Then, too, when the details of the various machines are considered, things look more discouraging; since machines that appear to be almost equals, vary greatly in the construction of their different parts. Such a wide difference is caused by the fact that dredges are usually designed for working on a specified improvement, and are constructed to satisfy all the requirements of the indicated work. As there are not two jobs alike, the dredges are built with such a large variety of details that it is difficult to find two dredges perfectly identical in every respect.

However, dredges can be divided into two classes, continuous and intermittent; the former removing continuously the material from the bottom of the body of water, while the latter engage the bottom at intervals. Continuous dredges are of four different types: the ladder, the hydraulic, the stirring and the pneumatic; while the intermittent are divided into only two classes, the dipper and the grapple dredges.

Each one of these different types of dredges can be subdivided again into various groups. All preserving, however, the principal characteristics of their type.

The ladder dredge may be mounted on a hull constructed not only for carrying all the various machines and housing the crew, but containing also large bunkers where the excavated materials are stored, while being transported to the dumping place. This type is called the sea-going ladder hopper dredge. On the other hand the hulk may be built so as to carry everything connected with the service of the dredge, while the excavated materials are dumped into scows, and thus we have the simple ladder dredge. It may be either self-propelling or stationary, depending upon the machines that are mounted on board the vesse permitting the dredge to go

from one place to another under her own power, or the dredge is moved by means of mooring lines and tugboats. Stationary ladder dredges may be constructed with the ladder on one side of the vessel or along the longitudinal axis of the boat; they may be built with towers of the ordinary height or with high towers in order to convey the débris to distant points along the shores.

Hydraulic dredges may be classified as sea-going, which are those able to steam from place to place under their own power, and those employed in the improvement of canals and rivers. In the sea-going dredges when the vessel contains large spaces for storing the débris, it is called the sea-going hydraulic hopper dredge; but when the hull is constructed similar to any other steamer without reserved space for the débris it is called the sea-going hydraulic dredge. The hydraulic dredges employed in the rivers and canals may be either self-propelling or non-propelling, the latter being the most commonly used, while the dredges employed in the improvements of the Mississippi and other large rivers are mostly self-propelling. These dredges, according to Mr. W. Robinson, may be classified according to the location of their feeders into lateral, forward, and radial.

The process of removing a very loose soil from the bottom by agitating the light particles so that they may be carried away by water is not very extensively employed at present. However, this stirring method has an historic interest and in some particular work it can be employed with advantage even to-day. The stirring of the material at the bottom may be obtained by means of different devices which will be described later on; they are: the harrows, the propellers, the converging revolving screws, jets of water, compressed air, etc.

Pneumatic dredges can still be considered in their experimental stage. Only one type of these machines has been built so far and this group of machine has no subdivision.

Dipper dredges present more uniformity, both in the general design and construction than any other type of dredge. They differ, however, in the material employed in the hull, in the dimension and efficiency of the machinery, capacity of the dipper, length of the handle and consequently depth of the reach, etc. But the large variety of details does not change the main characteristics of the machine, consequently subdivision cannot be made.

Grapple dredges are of two different types, the clamshell and

the orange-peel bucket. The bucket of the clamshell dredge is built of different shapes, depending upon the materials that the machine is designed to work upon. Thus, for instance, the bucket is made up of tines when the dredge is to work in a soil full of pebbles or small boulders, or is intended to pick up stones that have been broken up by blasting. A solid bucket with the edges provided with tines is used in connection with dredges intended to work in soils that are hard and compact, while a clamshell bucket without tines is used for working through very loose soils. The orange-peel bucket of the grapple dredge cannot be subdivided, being always of the same shape. Both types of dredges vary greatly in dimension of machines, although they are similar in their chief characteristics.

It is possible to divide all dredges into two classes, namely, self-propelling or non-propelling. A self-propelling dredge can be moved by its own power, but when not provided with self-propelling apparatus dredges are moved by tugboats, or by chains or moorings. All the sea-going dredges of the ladder and hydraulic type are self-propelling, while many of the same type of dredges as well as those of the dipper and grapple type are usually stationary or non-propelling.

Self-propelling dredges meant for harbor and river work are also rigged to be moved by hawsers and moorings, or by means of spuds.

The self-propelling dredges can be provided with motive power sufficient to move the boat while the dredging operations are going on, or it may be necessary to stop dredging in order to furnish the power for the propelling apparatus. In other words on the same machine the advance of the boat and the dredging operations can be made either simultaneously or alternately.

As stated, all the sea-going dredges are self-propelling and so are some of the dredges of small dimensions used in the excavation of rivers, canals, etc. The propelling devices vary; for instance, in the sea-going dredges it generally consists of one or two propellers of the same form and dimension as used in steamers of similar capacity. However, paddle-wheels are sometimes used. These may be located on each side of the boat as in any ordinary side-wheel boat which plies on the large rivers and bays. Paddle-wheels are not extensively used on dredges, owing to the fact that either the dredging or discharging apparatus is usually located on the sides of the boat. The propelling device may consist also of a single

paddle-wheel located at the stern, as used on some dredges employed on the Mississippi River, and in the dredge "Edward VII" shown in Fig. 37. The single stern wheel may also be provided with spikes, which engage the soil at the bottom of the river and canal. Special dredges employed by the French Government on the River Rhône have been so constructed.

Dredges may also be grouped according to the manner of disposing of the excavated materials. Thus the dredges may discharge the materials into hoppers of large capacity contained in their hulls, thus carrying and dumping their loads in deep waters. These are the sea-going dredges of the hopper type. Sometimes, though, the hull may be only large enough to carry the required machines and coal bunker or there may be room to provide accommodations for the officers and crew. Then the dredged material is disposed of in different ways. It can be discharged into scows to be dumped into deep water, or deposited wherever desired, as is commonly done with the ladder, dipper and grapple dredges. The material can also be dumped directly alongside the dredged channel, thus using it to form a levee. This method is used with the dipper and grapple dredges employed in cutting canals or dredging narrow rivers, and sometimes even with ladder dredges, but chiefly with those of the high-tower type. All the hydraulic dredges and some of the ladder dredges working through very loose soils, when they are not of the hopper type, discharge the excavated material through long line of pipes using it for filling lowlands, as is commonly done in reclaiming low, swampy ground.

The simplest manner of disposing of dredged material is the one used in connection with the stirring process. This consists in stirring up the material at the bottom of the water, thus bringing it to the surface by agitation and by allowing the velocity of the water to carry it away. Such a method, however, although very convenient and economical, is very seldom used, as it requires conditions that cannot be controlled by the engineer. This method, though, has been used on the Mississippi River and in the harbor of Swansea in England.

There are many dredges built of special design or meant for some particular piece of work, yet even when used on land they can be considered under the classification given. The main consideration should always be the adaptability of dredge.

In the United States dredges of many designs are used, and until

recent years, as a rule, it may be said that in the extensive harbor and river improvements only two types of dredges have been used, these being the single-bucket dredge, either of the dipper or grapple type, and the hydraulic dredge. The former is used in the excavation of soils that are hard and compact, while the latter is employed in very loose soils, as mud and sand. The powerful ladder dredge, so extensively used in all the foreign countries, has had but little use here. Such a disregard for one of the most efficient machines exposes the American engineers and contractors to severe criticism. Mr. A. W. Robinson has given some reasons that have induced the American to use these two types of dredges in preference to the ladder. In a new country more important improvements were required at first than dredging, and consequently the little dredging that was occasionally done in keeping the rivers and channels open to navigation was not done directly by the Federal Government, but given out on small contracts. Work was scattered along an extensive sea coast and done at different times, according to the necessity of the improvements and the small appropriations made. Consequently the contracts were small and there was no certainty of continuous work. Thus the dredging contractors found it more advantageous to work the cheapest machines even if its life was short. For this reason, until very recently the dredges employed in this country were mostly of the single-bucket type, as the original cost was small and they were very efficient and easily handled. Besides, they had the advantage of being used for other purposes than dredging, as lifting piles, lowering concrete blocks, raising wrecks, lifting boulders, loading scows, etc. The attention of the American manufacturers has been devoted to the construction of the type of dredges that were in demand. When, with the changed conditions of the country more powerful machines were required, these were constructed on the lines of the old ones, as dredgemen were skillful in their handling and the manufacturers had acquired great experience in their construction.

It has only been within a comparatively few years that the merits of the ladder dredge has been recognized in America. Even to-day contractors seem loath to use this type of dredge. However, during the past decade the Canadian Government has built a number of such dredges for use on the St. Lawrence River, and the Federal Government has rebuilt and used with great success some of the small ladder dredges used by the French on the Panama Canal.

These rebuilt dredges have by their work on the canal attracted the attention of both engineers and contractors. The great field for ladder dredges in America has been in the gold mining section of the Western States. Although originally used for this purpose in New Zealand, the idea was brought to the United States, and the development of this type has been rapid. The buckets have been increased in size until some of the latest machines use buckets of $\frac{2}{3}$ cu.yd. capacity.

The hydraulic dredge is comparatively a very modern machine. It was introduced on public work after the United States had grown and work of great magnitude was necessary to keep pace with the wonderful progress of the country. The navigable channels were widened, the rivers and harbors deepened to accommodate the modern and ever-growing leviathan of commerce, and in such work the hydraulic dredges were found to be the most convenient and efficient. They were used extensively in the harbors and bays along the Pacific coast, and along the Atlantic shores they have now almost supplanted the single-bucket dredges used in former days. The great dredging work going on continuously in this country in the last few years has aroused great competition among the contractors, who have constructed powerful machines so to as obtain competitive work and perform it at the smallest cost. Consequently in America are now found the largest and most powerful dredging machines in the world. But hydraulic dredges, although very efficient in sandy soils, are not so efficient in hard soils. Heretofore such soil has been excavated by the bucket type of dredge.

The capacity of dredges varies exceedingly, and it is difficult to give data as to the amount of material that can be excavated by dredges of different types. The character of the material, the depth of the water, the current and amount of traffic in the river, harbor or channel, the size of the engines on the dredges, the size of the pumps, buckets, or dippers—all of these conditions and many more affect the amount of work done.

For instance a small elevator or ladder dredge of the hopper type excavated 1400 cu.yds. of soft material in a 10-hour day, while in average earth it excavated 1000 cu.yds., and in very hard material 350 cu.yds. only. Hopper types of dredges always mean reduced output, as the time is lost for digging that is consumed in going to the dump. Inefficient scow service also serves to decrease the output of the dredges. Many records could be given of indi-

vidual dredges, but a general idea can be obtained from the following data:

Elevator or ladder dredges with small buckets, that is from 4 to 10 cu.ft., will excavate from 150 cu.yds. of hard material to 2000 cu.yds. of soft material in a 10-hour day. Working in average earth under ordinary conditions about 1000 cu.yds. can be excavated. With buckets from $\frac{1}{2}$ to $\frac{3}{4}$ cu.yd. capacity the output will vary from 500 cu.yds. in hard material to 3000 in soft mud. In average earth from 1500 to 1800 cu.yds. can be handled in a 10-hour day. With buckets from $\frac{3}{4}$ to 1 cu.yd. from 1000 to 6000 cu.yds. can be excavated, doing in average earth in a 10-hour day, about 3000 cu.yds.

Dipper dredges are seldom made with buckets of less than 1 cu.yd. capacity. A comparison of a large number of records of dipper dredges of various sizes shows that machines of this type working in soft mud will excavate just about twice as much as in hardpan and such soils. When logs and boulders are encountered less than this amount is excavated.

A machine with a 1 cu.yd. dipper will excavate from 300 to 800 cu.yds., doing in average earth about 500 cu.yds.; with a 3-cu.yd. dipper from 1000 to 2000 cu.yds. can be excavated; and in average earth about 1500 cu.yds. With a 6-cu.yd. dipper 5000 cu.yds. of average earth should be excavated in 10 hours. With dippers having a capacity of from 9 to 10 cu.yds. about 8000 cu.yds. should be excavated in average earth, in 10 hours.

With grapple dredges there is generally a less output than with dipper dredges, as they are generally used in deeper water, and then too the movement of the bucket is slower. With small buckets working in hard material, such as hardpan, some records show as small an output as 180 cu.yds. in 10 hours. The "Fin MacCool," described later in this treatise, with a 10-cu.yd. clamshell bucket excavating in deep water, dug 2800 cu.yds. in 10 hours. However, there are some records with smaller buckets of 4000 to 5000 cu.yds. per day.

Hydraulic suction dredges must have their work gauged by the size of the pump, depth of water, and length of discharge pipe. Pipes up to 2000 and 3000 ft. are very efficient; over this distance the friction in the pipes is great, but many dredges are designed to-day to pump material from 4000 to 5000 ft. The longest pipe line known to the writer was $2\frac{1}{2}$ miles. The smallest record for a day's work

with a suction dredge of the hopper type known to the writer is 250 cu.yds. in 10 hours. This dredge had a 12-in. pump. Other small dredges discharging through pipes show records of sand of about 500 cu.yds. From these small records they go up to figures that are enormous. The "J. Israel Tarte," with 36-in. pump, averages from 12,000 to 20,000 cu.yds. per day. The "Francis T. Simmons" has a number of hourly records of 3000 cu.yds. per hour. The "Atlantic and Manhattan," hydraulic hopper dredges with 20-in. pumps, working in the Ambrose Channel, averaged during one season about 9000 cu.yds. in 24 hours or 3700 cu.yds. in 10 hours. The "Galveston" places in its 1400 cu.yd. hopper 1350 cu.yds. in 45 minutes. Some records are much higher than these. The largest dredge in the world is the "Leviathan." Working in the Mersey River in England 10,000 cu.yds. of sand was excavated in 50 minutes. This was at the rate of 120,000 cu.yds. in a 10-hour day. This dredge can excavate to a maximum depth of 70 ft.

CHAPTER X

LADDER OR ELEVATOR DREDGE. GENERAL DISCUSSION

THE ladder or elevator dredge consists of a series of steel buckets, attached to two parallel endless chains running along a trussed ladder and revolving around two drums or tumblers, located at the extremities of the ladder. The ladder is kept in an inclined position, its upper end resting on a tower mounted on the boat while the lower end is under water, raised and lowered by chains. The dredging apparatus together with all the required machinery is mounted on a vessel which can be easily moved from place to place. The work of the ladder dredge is easily understood. The steel buckets forming an endless chain in passing around the drum at the lower end of the ladder are brought in contact with the soil and scrape it. The buckets filled with the removed material ascend the ladder and in passing over the upper tumbler empty their contents into a chute from which the material falls into scows of other receptacles and is conveyed to distant points.

The hull of the ladder dredge is made of different shapes and materials, depending upon the work to be done. To insure stability, it is desirable to have the hull of the dredge as wide as possible, and yet in the sea-going dredges the hull should be made narrow and long in order to insure seaworthy qualities in the vessel. The hull can be made either of steel or wood. In dredges of small capacity the hull is usually made of wood, but dredges of larger capacity, as for instance all the sea-going dredges and also many of those employed in the harbors or wide rivers, have the hull made of steel. The advantages derived from employing steel hulls are: (*a*) that the structure will be more solid and compact, (*b*) that the hull built of stronger material will occupy less space thus leaving more room for the machinery, (*c*) the vessel will be of lighter draft and will be very stiff, thus avoiding vibrations that are always found in dredges with wooden hulls and dangerous on a machine mounted on a float, since the continuous strong vibrations will tend to disconnect the various parts of the machinery.

When the ladder is located on one side of the vessel, the hull is constructed like any other vessel, but when the ladder is located at the center and along the longitudinal axis of the vessel, the hull is provided with a pit or well. The dimensions and form of the pit vary with the work of the dredge. In dredges constructed to lower the level of deep channels or harbors, the ladder working always at given angle, has its lower end submerged. In such cases the pit is located amidship and the hull will be a closed one, except for the pit. The ladder can be located at the bow both in navigating and dredging. When the dredge is constructed to work in both shallow and deep water and even to cut its own channel, the ladder must be arranged to be raised and lowered, consequently the pit should extend through the stern of the vessel. In this arrangement the hull is open in the stern and a strong frame or gantry built on deck is used to connect together the two separate walls of the pit, while the ladder is raised or lowered by means of chains and pulleys attached to the gantry. In any case the pit should be wide enough to permit the ladder to work on a small radius.

The ladder consists of a strongly built trussed beam kept in an inclined position and provided with a tumbler at each end. Along this beam and around the drums travel two endless chains carrying the buckets. The upper end of the ladder is fixed to a tower by means of turnbuckles which permit the adjusting of the chains to the required tension. The lower end is suspended by chains passing over pulleys fixed to the gantry. Chains attached to a drum of a reversible engine regulate the raising and lowering of the ladder. To facilitate the running of the chains and loaded buckets in their ascent along the ladder, the upper side of the trussed beam is provided with rollers.

The tumbler or drum at the lower end of the ladder is meant to guide the endless chains and buckets. These, however, are moved by the driving tumbler located at the upper end of the ladder mounted on a tower. Since all the strain of dredging apparatus falls upon the upper tumbler, this is built very strong and it is usually made of cast steel. Its cross-section is made as closely as possible a circle of the smallest diameter; but in order to smoothly drive the endless chain it is made polygonal, each side being equal to the links of the chains and length of buckets. As a rule the driving tumbler is made of pentagonal cross-section, thus wearing all the faces equally, which would not be possible with a square or hexagonal cross-section,

when buckets and chains would always fall alternately on the same faces and consequently would wear out unevenly. The lower tumbler is made as large as possible with a polygonal cross-section of six or seven sides.

The endless chains are built up of links of soft untempered steel; the links are connected together by cast-steel bolts, the bolt holes being lined with soft steel rings in order to be easily renewed when worn out, thus preventing the bars of the links from wearing.

Steel buckets of different shapes and capacity are attached to every second link of the two parallel endless chains. The buckets are generally made of two different shapes, either prismoidal or as round as possible. The lower bucket of prismoidal form is not very satisfactory, especially in clayey soils, when the material tends to adhere to the corners and bottom; but the buckets should not be very round either, since the lower part must be flat in order to easily slide on the upper side of the ladder and revolve smoothly around the tumblers. All the buckets are made of steel, reinforced at their cutting edge. Buckets used on loose soil are reinforced with a ring riveted to the edge of the bucket, but those used in the excavation of rock or very hard soil are reinforced by strong projecting steel teeth riveted to the bucket so as to be easily replaced when worn out. The capacity of the buckets working through loose soil varies between $\frac{1}{2}$ and 1 cu.yd., while that of the buckets used on rock varies between 7 and 13 cu.ft. To extend the usefulness of the machinery every ladder or elevator dredge should be provided with two sets of buckets, thus making the machine available in any material.

The tower of the ladder dredge may be constructed either of iron or wood. Dredges with iron towers are lighter, of less draft and stiffer than those provided with wooden towers, besides, the machinery runs smoother and with less vibration. Yet many dredges, especially those employed on narrow rivers and canals, are even today constructed with wooden towers. When wood is employed in the construction of the tower, its upper part is usually reinforced with packing pieces at the points where shafting causes heavy strains and vibrations. Yet in spite of perfect adjustment working at the beginning, owing to the elasticity of the material and through friction, the joints rack and the whole packing becomes loosened.

Tower dredges are classified as low- and high-tower machines. The former are those with towers not more than 20 or 25 ft.

above deck, while the latter are constructed with towers 75 and even 80 ft. high. As a rule, nearly all the ladder dredges either of the hopper type or those in which the material is dumped into scows, have low towers. High towers are employed on dredges used in narrow canals and rivers, which dump the dredged material, by gravity, through a long inclined conveying tube, the material being used for filling lowlands along the shores of the rivers or forming the levee or dykes of canals.

When the buckets, filled with the dredged material, reach the top of the ladder and revolve around the driving tumblers they discharge their contents into a large box in communication with an inclined chute. Both the box and the chute are covered in order to prevent the material from splashing on deck. With low towers, located at the center and dumping material into scows, there are usually two chutes so as to load scows located on each side of the dredge. By a system of chains and pulleys the chutes may be called into service one at a time or simultaneously, at the will of the operator. The inclination of the chute depends upon the quality of material to be dredged. Mr. Webster gives the following inclinations for the various materials:

Soft mud.....	1 in 10
Soft clay.....	1 in 12 or 14
Hard clay.....	1 in 14 or 16
Fine sand and water.....	1 in 20 to 25

Power is conveyed to the driving tumbler by endless chain and sprocket wheels, by belt connection and by direct action of the engine through a system of cog wheels. The method of turning the driving tumbler by an endless chain and sprocket wheel works very well in loose soils, but in rock and hard soils the sprockets have a tendency to break easily. The method of transmitting the motive power to the dredging machinery by means of a belt connecting the flywheel of a horizontal engine with a system of cog wheels acting directly upon the driving tumbler works well in loose soils, but in tenacious material the belt has a tendency to slip. This can be partially overcome by an attachment fitted with a tightener pulley, which can increase or decrease the tension of the belt. Such an arrangement has given satisfactory results except in dredges working through rock. Another manner of conveying the power to the driving tumbler is by a system of gear wheels acting directly

from the pistons of vertical engines. This method is commonly employed, as it works well through any material, and the speed of the motion on the ladder can be varied independently of the engine.

The efficiency of the ladder dredge is determined by the number of buckets that pass over the driving tumbler every minute, which as a rule varies between 15 and 20. But the efficiency really depends upon the material to be dredged and the capacity of buckets employed. Smaller resistance is encountered in dredging loose soils and consequently the driving tumbler may run at greater speed and more buckets will pass over it every minute; yet in clayey soils it is necessary to run the tumbler at reduced speed in order to give time to the sticky clay to detach itself from the buckets. In removing rock it is necessary to attack the material with great force, consequently the buckets are run at high speed, hence a greater number will pass every minute over the driving tumbler. However, the buckets, in order to be stronger so as to easily break the rock, will be of smaller capacity than those employed for dredging loose soils. Thus the efficiency of the dredge depends upon the material to be dredged and the capacity of the buckets, which, however, should be filled up only to $\frac{3}{4}$ of their capacity. In general, when the dredge is working in shallow water, the buckets are traveling at a slight inclination only and consequently the buckets will be only partially filled, while they will be full when working in deep water, when the ladder will be in almost a vertical position. Consequently the inclination of the ladder should also be taken into consideration in determining the efficiency of a dredge.

In the ladder dredge a large amount of power is wasted in overcoming the great friction of the various parts of the machinery. Mr. Webster, after an accurate series of experiments, was able to deduce some practical rule, determining the power required to work a ladder dredge through different materials. The result of his experiments are expressed in the general formula:

$$\text{I.H.P.} = CW\sqrt{H}$$

in which C is a coefficient varying with the different materials;

W = number of tons per hour to be dredged;

H = height of the upper tumbler from the bottom of the surface ground to be dredged.

The different values of C are 0.04 for very stiff clay and mud,

0.034 for hard clay and indurated mud and 0.026 for soft mud and light sand.

Manufacturers have built a very large variety of ladder dredges. These, however, for sake of classification, according to the locality in which they have to work, can be broadly grouped as follows:

1. Sea-going dredges;
2. Harbor and wide river dredges.
3. Canal and narrow river dredges.

CHAPTER XI

SEA-GOING LADDER DREDGES

THE sea-going ladder dredges are those usually employed to work in the open sea or for service in harbors. They are built to sail under their own steam. Great care is necessary in designing the hull of such dredges, as they should be even stronger than the hull of ordinary steamers, in order to insure their stability against the roughness of the sea and the strain of the work. For these reasons the hull of the sea-going ladder dredges is always made of steel, thus obtaining great stiffness and solidity. The hull is divided into various compartments separated by water-tight bulkheads so as to attain an unsubmergible vessel in case one of the compartments should be invaded by water.

The sea-going ladder dredges are self-propelling. They are usually provided with two ordinary propelling screws located on both sides of the stern or pit according to the type of the dredge. Only ladder dredges of small capacity are furnished with a single propeller; but it is always preferable to have two propellers even in the small dredges of light draft. The propellers can be operated by separate engines, or by the engines of the dredging machinery; in such a case a single device permits of easily shifting the power from dredging to the propellers and vice versa.

In sea-going dredges on account of stability the tower is located amidship and the ladder along the longitudinal axis of the steamer. When the dredge is designed to work in deep water the ladder remains in a well. The hull is closed forward, the ladder remaining in the bow of the steamer both in navigation and in dredging. When the dredge is designed to work at varying depths, the ladder must assume different inclinations and even be raised above the water line; the pit is accordingly open and located aft. The boilers and engines are located forward. In such a case the bow in navigation becomes the stern in dredging.

Sea-going ladder dredges moving continuously from one place to another must be provided with commodious quarters for the

officers and crew. Should also have on board a well-equipped repair shop, so as to repair immediately the complicated machinery when out of order. The steamer should have storage for a supply of fresh water, coal and food, besides the interchangeable parts of the various machines.

Sea-going ladder dredges are built of two different types, viz., the single and the hopper dredge. The single sea-going ladder dredges proper consist of a strong vessel carrying all the dredging, propelling, and other machines and boilers. The tower is located amidship with a central chute terminating on either side of the vessel in order that the material may be easily discharged into scows.

The hopper dredge is constructed in a similar manner, the only difference being that the hull is much larger and between the tower and the machinery there is a large space to hold several hundred tons of material which enters the hopper by means of a chute. The bottom of the hopper is provided with trapdoors controlled by chains attached and revolving around two horizontal shafts, so that the doors can be closed or opened at will. When the hold is filled up with débris, the dredging operations are suspended and the vessel goes out to deep water, where the doors are opened, and the material will fall to the bottom by gravity. Then the vessel returns and resumes its dredging operations. This machine, working continuously day and night, is provided with powerful illuminating apparatus to make clear its way.

The following description of the dredge "Ville de Rochefort," taken from *Engineering*, illustrates the simple sea-going ladder dredge.

In 1897 the French Government intrusted to the important firm of engineers at Lyons, MM. Satre, Fils Aîné et Cie., the construction of a powerful marine bucket dredge, with twin screws, intended for deepening and maintaining the navigation channel of the Charente.

This river, on which is placed, at a considerable distance inland, one of the five great military ports of France—the port of Rochefort—requires to be considerably deepened to allow the passage of fully equipped ironclads between Rochefort and the sea.

Not only is there a rocky bar at one point, but vast quantities of mud are constantly being deposited on the river bed, seriously reducing the available depth of water.

For this reason the French Admiralty considered it necessary

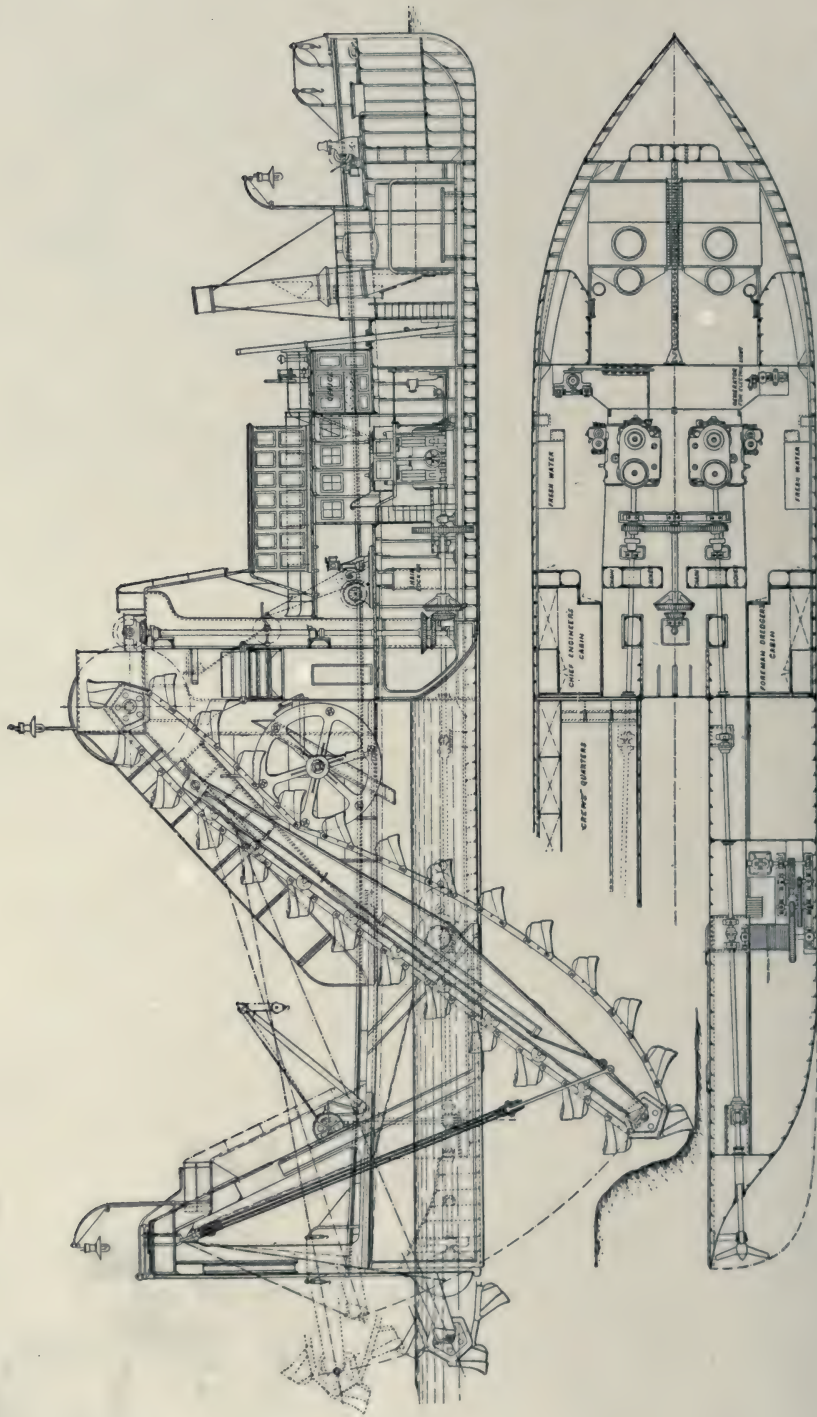

Figs. 15 and 16.—Side View and Part of the Deck Plan of the Dredge "Ville de Rochefort."

to have at its disposition a dredging machine sufficiently powerful to maintain the navigable channel open at all times.

This machine has recently been delivered by the constructors at the port of Rochefort after a series of interesting trials, to which reference will be made later.

The general view of the dredge is given in Figs. 15 and 16.

It is provided with a single inclined central ladder, and is fitted with two screws.

The engines are of sufficient power to give a speed to the vessel, when loaded, of 6 knots, and to insure an efficiency, under unfavorable conditions of weather, of a minimum of 330 cu.yds. of compact mud such as forms the bottom of the River Charente, at a depth of 33 ft. below the surface.

The hull is constructed with an open end to provide a passage for the ladder, and to allow the dredge, in case of necessity, to make its own channel as it advances; the position of the ladder can be shifted in such a way as to excavate against fixed works (such as quay walls) 13 ft. in advance of the hull, in slight depths.

The material raised is discharged through two side passages on either side of the vessel.

The hull, which is built entirely of steel, has the following principal dimensions:

	Ft.	In.
Length on deck.....	144	6
Width.....	32	9
Depth.....	11	2

The hull is divided into nine compartments by eight watertight bulkheads.

The internal fittings of the vessel for the officers and crew are very complete; they comprise a cabin for the engineer in charge, which also serves as the watchroom, placed on the upper deck; the captain's cabin is on the main deck; beneath the upper deck is a large messroom for the officers; and on each side is arranged the accommodation for the engineers, the dredging staff, and the crew.

The propelling machinery consists of two compound surface-condensing engines of the steam-hammer type, capable of developing together 500 horse-power.

These engines are arranged either to drive the scows or the dredging machinery, a simple and quick-acting system of clutches being provided to make the connections with one or the other.

The dredging machinery is driven by gearing through a brake transmission to avoid the danger of fracturing any part of the machinery in the event of a sudden shock arising from contact with unusually hard material.

The engines are arranged to be driven together or separately, so that the power of one or both can be applied to the screws or to the dredging machinery.

The principal dimensions of the engines are as follows:

	Inches.
Diameter of high-pressure cylinders.....	20.08
Diameter of low-pressure cylinders.....	34.26
Length of stroke.....	19.69

Each engine is provided with a separate starting gear driven by a special motor, so that the engines can be turned at slow speeds down to two revolutions a minute, to facilitate the operations of mounting or dismounting the bucket chain.

The boilers, two in number, are of the ordinary marine type, registered to a working pressure of 114 lb. per sq.in., and of ample capacity to drive the main and all the auxiliary machinery.

The gearing which transmits the motion from the engine to the bucket shaft is so arranged that its speed can be varied independently of that of the engine.

This arrangement is desirable in consequence of the variable nature of the material which has to be lifted.

The bucket ladder is central and is placed in the middle of the hull; it is so hung that the bucket wheel at the lower end can be raised clear of the water when the vessel is being propelled; its length is sufficient to dredge at a depth of 33 ft. below the surface.

It is mounted in such a manner that it can be easily shifted aft, when it is desired to remove the mud lying against the foot of quay walls in a slight depth of water.

The bucket chain is made of links of soft untempered steel connected by cast-steel bolts; the bolt holes are lined with soft steel rings which can be easily renewed when worn.

The buckets are made entirely of steel with a reinforced cutting edge; their capacity is about 1 cu.yd., they can be driven at speeds varying from 10 to 16 buckets past the discharge channels per minute, according to the nature of the ground being excavated.

The winches for lifting the ladder are driven by a separate compound engine of sufficient power to raise the ladder when the

buckets are all loaded. The dredge is lighted throughout electrically; internally by incandescent lamps, and on deck by arc lamps; current is furnished by a Laval electro-turbine plant.

With regard to the trials made with this dredge, we cannot do better than reproduce a part of the official reports of the Commission nominated by the Minister of Marine: "The trials provided for by the terms of the contract were carried out on June 18 last, at the same time the machinery was tested for the consumption of fuel.

"The speed obtained was 6.053 knots; the consumption of fuel contracted for was 2.09 lb., but the tests showed a consumption of 1.97 lb. per horse-power per hour.

"The trials were continued for six consecutive hours, during which the working was extremely satisfactory.

"The tests for dredging efficiency were made with material similar to that found in the bed of the Charente; the Commission continued these tests for 60 hours consecutively.

"It reported that the dredge worked with one engine and one boiler, and that, at the minimum speed of ten buckets per minute, it gave an average efficiency of 485 cu.yds. an hour; this amount included the time necessary for operating the discharge channels, and stopping and starting the machinery; without including these delays, the amount raised was 6536 cu.yds.

"From the foregoing it will be seen that the efficiency is largely in excess of the terms of the contract, which prescribed a total of 333 cu.yds. per hour.

"The consumption of fuel measured direct under the most unfavorable conditions, averaged 102.76 lbs. per loaded barge, equivalent to 1.08 lbs. per cu.yd. lifted.

"By the terms of the contract 1.53 lb. of fuel per cu.yd. were allowed, so that in all respects the results were highly satisfactory."

The Commission reported in an equally favorable manner on the electric installation.

The following description of the Pas-de-Calais dredges, translated from the *Genie Civile*, serves to illustrate a ladder dredge of the hopper type.

The hopper ladder dredge "Pas-de-Calais," see Fig. 17, was built by the Henry Satre Fils Ainé et Cie. for the French Government for the use of several harbors along the English Channel, but mainly for the Naval Station of Boulogne. In order that the dredging

operations and especially the continuous movements of tugboats and scows in the service of the dredge would not interfere with traffic through the narrow channel, and also on account of the heavy seas prevailing in the locality, it was decided to build this ladder dredge with a large hopper to receive the débris. The hopper loaded, the steamer would go out to unload its cargo into deep water and return to resume its dredging operations.



FIG. 17.—Dredge "Pas-de-Calais."

The principal dimensions of the steamer are:

	Ft.	In.
Length.....	180	3½
Width.....	32	7
Depth.....	14	6

The motive power is provided by two independent compound engines with three cylinders each, developing together 650 H.P. The engines are furnished with a regulator, by means of which it is possible to regulate the speed of the buckets according to the resistance of the soil encountered in dredging.

Steam is generated by two tubular boilers of marine type and so arranged that they can work either together or separately and

supply either one of the engines or both. The grate is of an improved type, which permits fuel of every description to be burnt.

The turning of the upper tumbler commanding the bucket chain is by a system of shafts and cogwheels. A friction clutch, easily handled, is attached to the upper tumbler in order to prevent any break in the various parts of the machinery in case very hard rock or other serious obstacles are encountered.

The dredge is provided with two sets of buckets; those to be used in loose soils or in soils of the average consistency have a capacity of 21.5 cu.ft. each; while those designed to work in soils of greater resistance, as conglomerates, ledges of rock, etc., are of 12.4 cu.ft. capacity and are strongly reinforced with steel teeth, which are fixed to the buckets in a very simple manner, so as to be easily changed when worn out.

Starting gears allow the engines to be turned at a very slow speed in order to facilitate the mounting or dismounting of the buckets.

The hopper is located amidship and has a capacity of 700 tons. The hopper is filled through a central chute. There are also two lateral chutes in order that the débris may be dumped on scows placed alongside.

The bottom of the hopper is formed by 12 gates made of wood lined with sheet iron. Each pair of gates is controlled by 6 chains wound around a horizontal axis. After the material in the hopper has been dumped the gates are closed again by means of a special engine acting directly upon the horizontal axis commanding the chains.

The bucket ladder is arranged to work at different depths, varying from 10 to 40 ft. The special construction of the hull allows the bucket ladder to move in a parallel direction and also to be raised and lowered. On account of such an arrangement the dredge may cut its own way and also dredge against the bottom of quay walls.

On the back of the ladder there is a pentagonal wheel for the support and guide of the bucket chain. Such an arrangement has the advantage of allowing the ladder to work in a more vertical position and to shorten at the same time the length of the bucket chain. Besides, the bucket chain resting on this wheel will run more smoothly than before, thus avoiding shocks and much wear.

The journals of the axles of the upper tumbler of the ladder are provided with Belleville springs, absorbing the shock produced by the buckets encountering some extraordinary obstacle. Owing

to the elasticity of the upper portion of the ladder, many breaks are certainly spared to the dredging machines.

All the winches are moved by independent double cylinder engines; the winch controlling the ladder is provided with friction clutches of Minoto's system and also with a friction brake applied by means of a lever arm. The lowering or raising of the ladder is done by means of lever arms controlling the drums of the winch around which the chains holding the lower end of the ladder are played in or out.

A steam crane is located at the bow of the steamer for lifting the rocks too large to be taken up by the buckets; while a second steam crane is mounted on deck for the raising or lowering of the ladder. Both cranes are provided with friction clutches of Minoto's system.

The motive power, as indicated above, is provided by two independent engines. These are so arranged that each one of them may act either on the propelling or dredging apparatus. The advantage of such an arrangement is that in case one of the engines breaks down the work will continue without interruption. Besides, these two engines can be easily coupled so as to act directly on the dredging apparatus when working in hard material. On the dredge there are two propellers, four bladed, with their shafts in continuation of the revolving shafts operated by the engine. The great advantage of two propellers is that the vessel may turn in a small radius when the two propellers are revolving in opposite directions. A simple movement allows the power to be changed from dredging to the propellers.

On account of the heavy seas prevailing in the locality the dredge was made a real steamer. Sailing under her own steam she went alone from Marseilles to Boulogne and on such a long voyage she proved her seaworthy qualities. The hull is entirely of steel divided in various compartments separated by watertight bulkheads to insure its floating even in case one of the compartments were injured.

The dredge is equipped with every device ordinarily found on a modern steamer.

The messroom and quarters for the officers and crew and the cabins of the engineers and captain are well heated and ventilated and are lighted by electricity. Powerful arc light lamps mounted on deck furnish light for work at night.

CHAPTER XII

SEMI-SEA-GOING STATIONARY AND HIGH-TOWER LADDER DREDGES

THE ladder dredges designed to work on rivers, canals, or within well protected harbors are built of different types. For sake of classification these various dredges can be grouped into semi-sea-going,

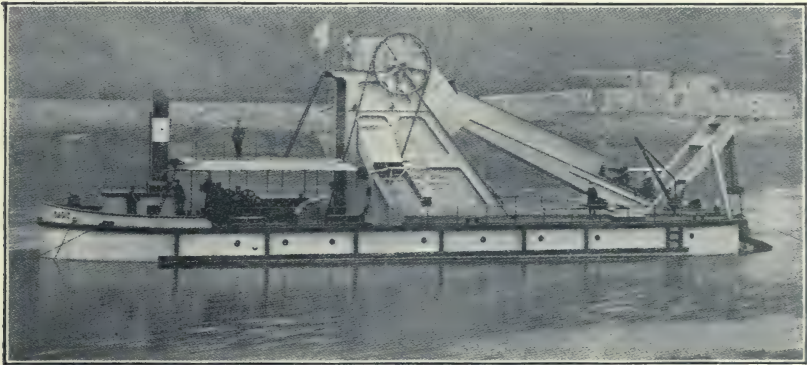

FIG. 18.—Dredge "Cadiz."

which are provided with self-propelling apparatus and stationary, not equipped with propelling machinery, and must be towed from place to place, and again we have the high- and low-tower types.

Semi-sea-going ladder dredges have the hull so constructed as to insure stability and steadiness to the machinery under the great strain of the work rather than to give seaworthy qualities to the steamer. The ratio between the length and width of the hull of these dredges is smaller than in those of the sea-going type. To allow the machine to work at various depths and consequently with the ladder at different inclinations the hull is always open and the walls of the pit are strengthened by a solid structure above deck. The ladder well can be located at the bow of the steamer and then the boilers and engines are aft, or vice versa.

With semi-sea-going dredges, navigating in waters which are usually quiet and calm, the propelling apparatus is of secondary importance. This consists of a single screw located at the stern in the ladder pit, when the stern in navigation becomes the bow in dredging. Fig. 18 shows the semi-sea-going ladder dredge "Cadiz" built by the H. Satre Fils Ainé et Cie. for the harbor of Cadiz, Spain, in which the propeller is located in the pit. The propelling apparatus may consist also of a single paddle-wheel located in the ladder pit.

It is not possible to use two side wheels on account of the chutes for the dredged materials. In such a case the walls of the pit are greatly extended as indicated in Fig. 19, which represents one of these dredges built by the H. Satre et Cie. and used in the canal between the Marne and Rhine rivers. The propelling apparatus may consist also of a sprocket wheel of large dimensions located at the stern. In revolving, the wheel will engage continuously the bed of the river, thus causing the forward motion of the dredge.

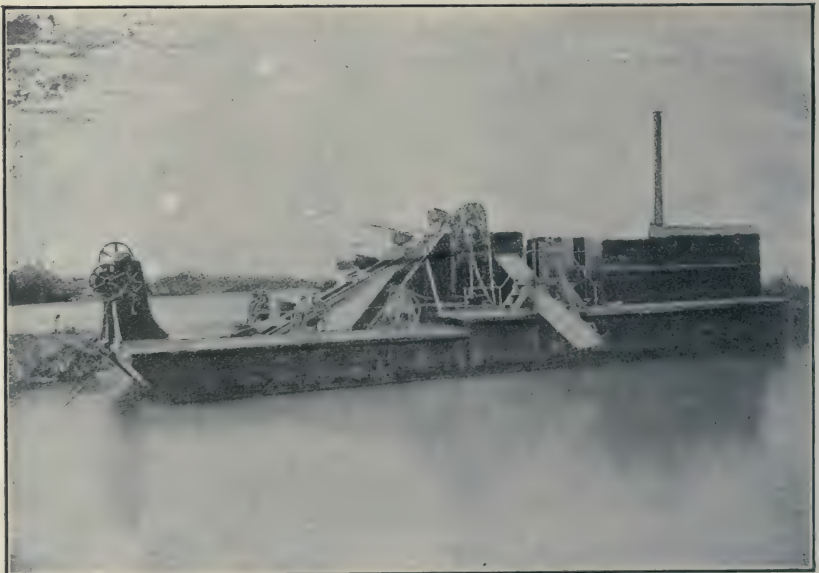

FIG. 19.—Dredge for the Marne Canal.

This method of propulsion was ordered by the Department of Ponts et Chaussées in France for dredges to be used in the improvement of the Rhône River, one of which is shown in Fig. 20.

Stationary ladder dredges are those without propelling apparatus. They are towed from place to place and the small movement required to follow the progress of the work is obtained by paying in and out the various ropes attached to the four corners of the boat and moored to distant points. Stationary ladder dredges of American construction are usually provided with three or four spuds so arranged that

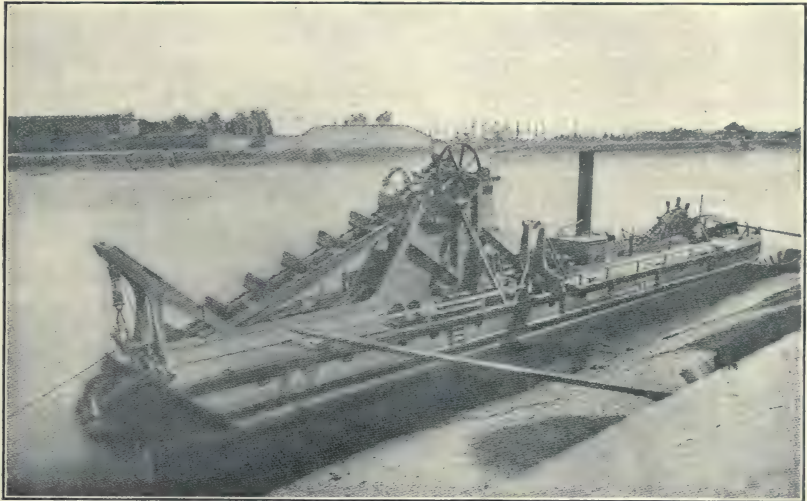

FIG. 20.—Dredge on the Rhone River Propelled by Sprocket Wheel.

when lowered the dredge will remain strongly fixed to the bottom. An advantage derived from using spuds consists in obtaining a machine that can be swung around one spud as center of rotation, thus dredging in great arcs or circles.

The hull of the stationary ladder dredge can be made of any shape, but as a rule it is made with a flat bottom like any ordinary float. The hull, however, is provided with the ladder pit, tower, bucket chain, boiler and engines similar to those used in the sea-going and semi-sea-going ladder dredges, with the only difference that all the machines are mounted on deck. Accommodations are not provided for officers and crew, as the men remain on board only during the working hours. The vessel is, as a rule, of very light draft and able to navigate and operate in very shallow waters.

Fig. 21 shows an ordinary stationary ladder dredge built by A. F. Smulders of Schiedam, Holland.

Following is the description of a stationary ladder dredge of American construction, a striking feature being that the excavated materials are conveyed to the shore by means of an endless belt conveyor. This machine was used on Fox River, Wis. and was described by Mr. L. M. Mann, the engineer in charge, in the *Engineering News*, October 25, 1906.

The plant as illustrated in Figs. 22 and 23 consists of a dredge with two intermediate and one delivering scow. The dredge is a regular elevator or chain-bucket dredge, having a chain of 39

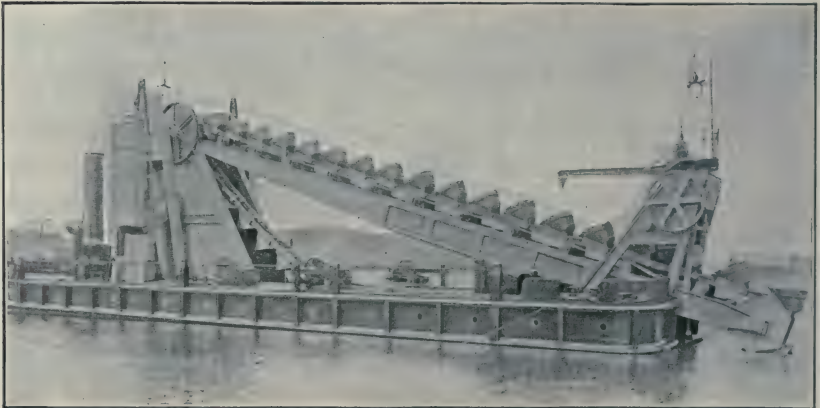

FIG. 21.—Stationary Ladder Dredge.

buckets of 5 cu.ft. capacity each rolling over a steel ladder. These buckets are provided with steel teeth for cutting up clay and digging the hardest material, and may be set to dig at any desired depth up to 10 ft. The dredge swings on a stern spud amidship, allowing it to dig on a circle of about 80 ft. radius, covering a width of channel of about 145 ft.

The material, on leaving the elevator buckets at the top of the ladder, is deposited in a hopper and passes thence onto a belt conveyor which conveys it aft over the stern of the dredge and delivers it into another hopper in the forward end of the intermediate or delivery scow. These several scows are provided with belt conveyors which keep the material in continuous motion until it is finally deposited where desired, either on shore or in a dump scow. The conveyor on this scow projects by means of a steel ladder over the stern a distance of 40 ft., and is hung from a

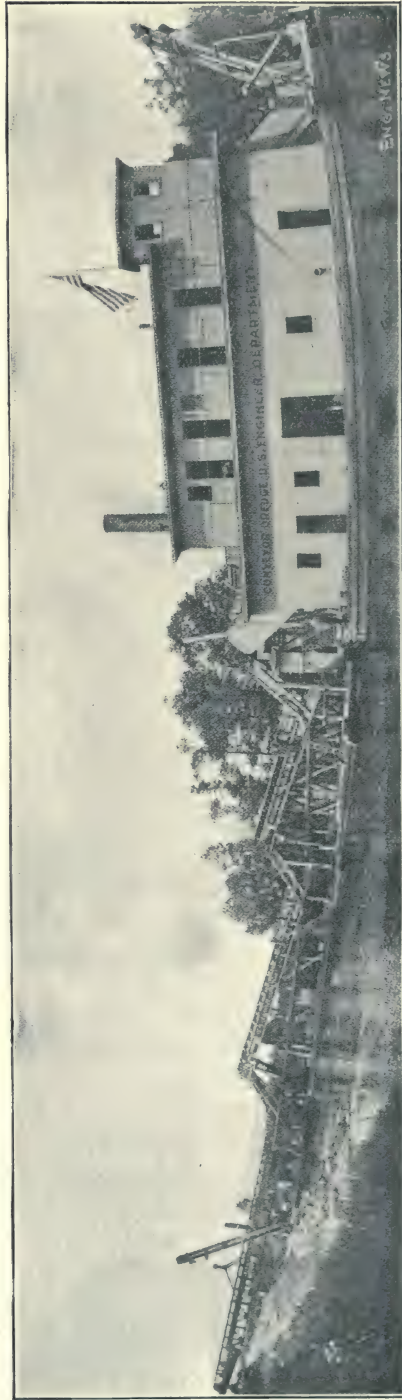

FIG. 22.—Stationary Ladder Dredge on the Fox River, Wis.

gantry, permitting it to be raised to 20 ft. above water or adjusted to any lower elevation. The latter scow may be swung at any angle to deposit the débris on either side of the river without disturbing the rest of the plant; or it may be attached directly to the dredge and used without the intermediate scows, which at first seemed a difficult problem to solve. The complete plant carries the spoil 300 ft. from the point of digging, and this distance is limited only by the number and length of the conveyors used. The conveyors are of the Ridgway type, but are protected on the sides and bottom to prevent spilling; the belt is rubber, 32 in. wide, and will easily convey the full delivery of the dredge.

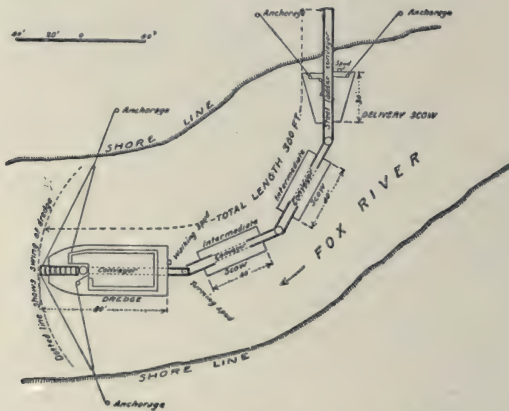

FIG. 23.—Dredging Plant Used on the Fox River, Wis.

The bucket chain of the dredge is driven by a 9×12 in. double reversing engine through gearing which also operates the ladder-hoist drum. A six-drum winch, driven by a 6×6 in. double engine, is also provided for operating anchor, spud lines, etc. A walking spud, operated by a steam cylinder, is provided to move the dredge forward. The belt conveyors on the dredge and scows are operated by electric motors supplied by a 35-KW. electric generator on the dredge directly connected with a 10×10 in. engine, which also furnishes electric lights for the plant and power for operating a 6-in. spray pump for cleaning the belts. Steam is furnished by a Scotch marine boiler 9 ft. diameter, 10 ft. long, water-back type, with two Adamson furnaces 35 in. in diameter.

The delivery scow is provided with a winch operated by an electric motor, for handling the anchor lines, gantry and spud.

Quarters for the crew are provided on the upper deck and are unusually spacious, light and well ventilated.

The hulls are built entirely of Oregon fir, the dredge hull being 75 ft. long, 31 ft. beam and 6 ft. depth of hold. The intermediate scows are 40 ft. long, 16 ft. wide and 3 ft. depth of hold, each carrying belt conveyors 65 ft. long. The delivery scow is nearly triangular in shape, being 31 ft. 4 in. long, 16 ft. 4 in. wide and 2 ft. deep at the forward or receiving end and 33 ft. 4 in. wide and 4 ft. deep at the after delivery end. The hull is given this unusual shape the better to support the overhanging load of the delivery conveyor, and to secure a greater angle of gyration when the scow is attached to the dredge. The width of the hull was limited to allow it to pass the locks, which are only 35 ft. wide.

The contract stipulated that the dredge should have a capacity of 250 cu.yds. per hour in ordinary digging. The first preliminary test demonstrated that she could dig 400 cu.yds. per hour; and she actually did dig 200 yds. in the toughest kind of clay and hardpan under adverse conditions. Although at times the buckets, when not full, carry considerable water, this flows back from the conveyors into the river and the spoil is deposited quite free from water. The crew of the plant now consists of 9 men, but can probably be reduced eventually. The cost of operation, including fuel, is about \$30 per day, but the plant will undoubtedly reduce the actual cost of dredging over the old dipper dredge 50 per cent or more. The cost of wear and tear cannot be determined, of course, until the dredge has been operated about two seasons. The principal wear and cost, no doubt, will be the rubber conveyor belts; but this will be minimized by the comparatively small repairs to the machinery as compared with a dipper dredge.

One of the most difficult conditions in the operation of this plant is the varying load, due not only to the varying depths of water in front of the dredge or the varying face of the cut, but the character of the material. Each requires a different adjustment of the machinery, that is, a different speed of bucket chain and conveyors. This may vary in a single turn of the dredge, as sand, clay, hardpan, or a mixture of these each act very differently. When a uniform load of gravel or sand is to be moved, the operation is much simplified.

High-tower Dredges. When the dredged materials are used for forming ditches or filling lowlands along the shore, the ladder

dredges are built with high towers. The materials are then conveyed to the dumping place by means of a long tube and they are discharged by gravity. The height of the tower depends upon two factors, viz., the distance of the dump and the elevation of the shores from deck. They are built of different heights, but always between 50 and 80 ft. The ladder is always located at the middle of the boat in an open pit.

When the buckets have reached the top of the ladder, while they revolve around the upper tumbler the materials fall into a bell leading to a closed chute, which is extended into a long tube. With dredges built to work in narrow rivers or canals, when both shores can be easily reached by the conveying apparatus, they are usually provided with two chutes and two tubes. In this manner were constructed the high-tower ladder dredges used on the Panama Canal under the French and also on the Nicaragua Canal. The conveying tubes are made of sheet iron 2 or 3 ft. in diameter. In dredges provided with only one long discharging tube this is located on one side of the boat at a right angle to the ladder. The tube is supported from the tower by a series of gang wire ropes and also from a trussed A frame located on one side of the boat and strongly fixed to the other side by means of backstays. The conveying tube is made of varying lengths, reaching sometimes 150 and even 180 ft. To reach points at great distances from the dredge the conveying tube is extended to land, but in such a case the land section of the tube is supported by specially constructed trusses. To facilitate the flow of the materials through the tube this is placed with an inclination varying from 2 to 10 per cent, depending upon the quality of the dredged materials. The descent of the materials through the tube is facilitated also by means of water jets forced by a centrifugal pump placed on deck, which continuously flush the tube.

The high-tower ladder dredge presents several disadvantages: 1st, the necessity of elevating the materials to a greater height than absolutely necessary, and consequently the motive power is not economically utilized; 2d, the necessity of acquiring powerful and expensive machines, which involve high running expenses; 3d, the stability of the dredge is greatly hampered on account of having very high towers on boats usually built of small dimensions; 4th, the material being deposited in a fluid state and near the edge of water has a tendency to run back again to the point of excavation.

Many engineers object to this type of dredge, while there are others who absolutely condemn it as obsolete. But when it is considered that in the ladder dredges, the coal consumption represents only 10 or 15 per cent of the running expenses, it is easily realized that the cost per unit of volume of the dredged materials will not be greatly affected by even doubling the cost of fuel. On the other hand the great advantage of these machines consists in the fact that they convey the dredged materials to the dumping place without additional cost of transportation. Consequently the small increase in the cost of dredging is more than compensated by the free conveyance of the débris to the dumping places. Another advantage of the high-tower ladder dredge consists in the fact that working day and night it will perform the work of two machines,

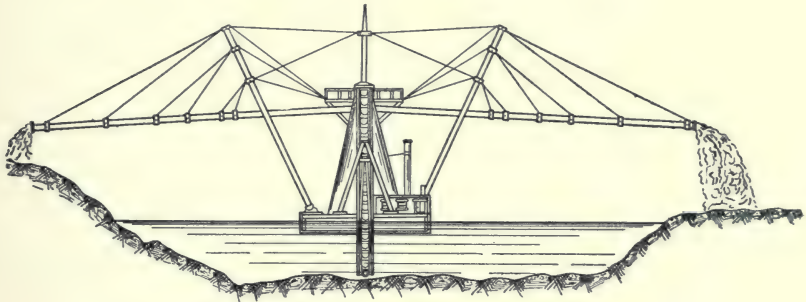

FIG. 24.—High Tower Ladder Dredge “City of Paris.”

thus greatly reducing the cost of the plant and the general expenses. Even to-day these high-tower ladder dredges in some classes of work will give the same satisfactory results as they did along the Suez Canal in the early days of their existence. Over one-third of the Suez Canal was excavated by means of these high-tower ladder dredges, and they were found very efficient in dredging the lower sections of the Panama Canal during the French Administration.

The following description of the dredge “City of Paris” taken from the *Scientific American*, serves to illustrate a high-tower ladder dredge built in the United States, and used by the American Contracting & Dredging Co. of New York for the Panama and Nicaragua Canals. Shown in Fig. 24.

The typical American dredge, represented by the “City of Paris,” is provided with composite hull 115 ft. long and 56 ft. wide. In

the forward end of the dredge is a slot, through which the lower section of the ladder, 36 ft. long and 7 ft. wide, descends. An endless chain of buckets travels up and down the ladder, cutting away the bottom wherever directed, and delivering the material to the discharger on top of the tower. The upper section of the ladder for this purpose is carried up to the top on an incline. A joint is provided between the sections, so that the lower portion can be raised and lowered. The upper section is 73 ft. 10 in. long. The buckets are of $\frac{5}{8}$ -in. steel, and have a capacity of 1 cu.m. each. The links of the chain are $1\frac{1}{2}$ in. x 1 in. steel, and are 3 ft. long. The shaft at the top of the tower, around which the chain and buckets travel, is 14 in. in diameter.

The chain is driven by double-cylinder engines, 16 x 24 in., with 10-ft. driving pulley with 38-in. face. The dredge is anchored by wooden spuds or heavy vertical beams, 25 in. diameter, with 1800 lb. iron shoes upon their lower ends. These ends are lowered to the bottom, and sinking through the earth anchor the machine securely. Besides the main engine, there are several auxiliary engines for working the spuds, raising the ladder, etc.

The material as dredged and raised to the top of the tower is emptied into the bell of one of a pair of iron chutes. These are pipes 3 ft. in diameter and 185 ft. long, which run far out on both sides of the tower. Water is pumped into them along with the solid material. Great banks of sand are built up by its operations.

When Mr. W. P. Williams, Sr., examined this dredge in the Panama Canal in 1889 under the French Administration, it was running nineteen to twenty-one buckets per minute, three-fourths full, three buckets to the cu.m. The expansion of material in buckets was 30 per cent, occupying more volume in the buckets than in bank. He estimated in twenty-four hours' work it would accomplish 4800 cu.m.

He gives the average efficiency of this machine as follows:

Soft sticky clay buckets not fully emptying at upper tumbler.....	3000 to 4000 cu.yds. per day
Hard clay.....	4000 " "
Sand.....	5000 " "

The machine is under the complete control of the captain, who is stationed on the bow of the machine. A system of wheels at his hand connects with the different engines, namely, raising and lower-

ing the lever, controlling the main engine and velocity of revolution of buckets, the gypsy engine working the side guys, the spuds also being raised and lowered by tackles on hoisting drums. The digger may, at a glance, take in the situation, and use his governing wheels accordingly.

The cost of the work can be deduced from the two most important items, which are the consumption of coal and the wages of the men handling the machine. Mr. Williams gives the consumption of coal in the "City of Paris" at 10 tons per day, while regarding the men he says that at the Panama Canal, there were from 45 to 55 men on these machines, distributed as follows:

1 captain.....	\$300	per month
3 assistant engineers	150	"
3 firemen.....	70	"
3 oilers.....	50	"
3 diggers.....	65	"
3 gypsymen.....	65	"
1 steward and three cooks.....	75	"
6 waiter boys.....	30	"
22-32 seamen.....	50	"

These men are divided into three watches of eight hours each, the machines working night and day, only stopping to repair machinery. Sunday is usually occupied in replacing any worn-out material, replacing links, and anticipating any breakages in upper tumbler bars, boiler tubes, spud gear, etc.

The American Contracting & Dredging Co. of New York was paid 35 cents per cu.m. and notwithstanding they paid such high salaries they realized over 50 per cent profit.

More recently dredges of this type have been successfully employed in dredging the Siass and Swirs Canals in Russia.

CHAPTER XIII

HYDRAULIC DREDGES—GENERAL DISCUSSION

IN working with ladder dredges of large capacity through different materials, European engineers discovered that it was more difficult to dredge through very loose material than in soils that were hard and compact. In fine sand and mud the impact of the buckets scraping the bottom caused the stirring up of the fine particles of the soil, to such an extent that it floated away, thus the buckets were mostly filled with water. In the harbor of Cette, France, a ladder dredge that used to excavate 180 cu.m. per hour of coarse sand and gravel could not excavate more than 45 cu.m. of fine sand. In the year 1867 M. Basin, a French engineer, presented to the Paris Exposition a model of a new type of dredge. M. Bazin proposed to raise to the surface the loose materials by means of a suction pump. The same method was suggested again in 1870 by Mr. C. Randolph, and in the following year it was used by Gen. Gillmore, U. S. A. in dredging the channel over the bar, at the mouth of the St. John's River, Florida.

Hydraulic dredges are of very simple construction. They consist of a pipe which reaches the bottom and is attached to a powerful centrifugal pump discharging the materials into another pipe, the whole being mounted on a float. Owing to the simplicity of construction hydraulic dredges can be built at a smaller cost than ladder dredges, and since they are more efficient on sandbars or at the estuary of wide rivers, they have become quite common and have been a success from their first appearance.

The efficiency of the hydraulic dredge has been continuously increased and to-day we have machines of over 3000 cu.yds. capacity per hour. The cost of construction of these machines has also increased in proportion. To give continuous employment to the hydraulic dredges they are now built to work through hard and compact soils. For such a purpose the lower end of the suction pipe is provided with different devices, designed to dislodge the

materials from their natural beds, and break the soils in such a manner that they may be readily taken up by the centrifugal pump.

Suction Pipe. The suction pipe is usually made up of four well-defined parts, which are: the connection to the pump, the joint, the tube proper and the agitator. The connection to the pump is made by an iron or steel pipe running on deck and bent in such a manner as to connect the tube proper with the pump. The joint as a rule is made of rubber; but owing to the wear of such material, it requires continuous repairing. To avoid this inconvenience, connections are now being made on some dredges by means of a ball-and-socket joint. The suction tube proper, which forms the real communication between deck and bottom, is composed of several sections of wrought-iron pipe from 10 to 20 in. in diameter, the size depending upon the efficiency of the dredge. These pipes are made up of sections 20 ft. in length each, provided with flanges and riveted together. They can be also made of steel plates welded together. Such pipes are stronger and lighter than those made of wrought iron. It can also be constructed of steel angles and plates. In any case the suction pipe should be strong in order to support either the agitator or rotary cutter attached at its lower end and also the shafts and gears for the rotation of the cutter. The length of this portion of the suction tube varies with the depth and nature of soil encountered.

Its length, as a rule, is determined in such a way as to have the suction pipe working at an angle of less than 45° . At some convenient point the suction tube is provided with a heavy steel ring, to which are fastened wire ropes, which passing over sheaves suspended from a gantry at the end of the boat, are wound around the drums of a reversible engine. In this manner it is possible to raise the suction tube above the level of water when operations are suspended, and lower it again to the bottom to resume work.

The lower end of the suction tube is usually provided with some devices to feed the tube in the most convenient way. Of the various devices the most commonly used ones are: the scraper, the rotary cutter, and jets of water or compressed air.

Agitators. The scraper used at the end of the suction tube consists of a wide broadened extension of the pipe so as to dig a furrow as wide as possible. It is covered with a steel apron and is provided

with openings on the lower face and also with scrapers. This end attachment of the pipe, being dragged along the bottom, scrapes the soil, which enters into the box at the openings and is drawn into the tube by the force of the pump. Fig. 25 shows the Allen scraper or drag as designed by Mr. J. P. Allen and used in the U. S. dredges "Manhattan" and "Atlantic" in New York Harbor.

When the hydraulic dredge is designed to work through hard soils the end of the suction tube is provided with a cutter. This consists of a number of knives (6 to 8) united by suitable disks or rings at one or both ends. The knives may be either straight or spiral, mounted around and concentric with the end of the suction pipe, and encased in a cast-steel hollow shell provided with open-

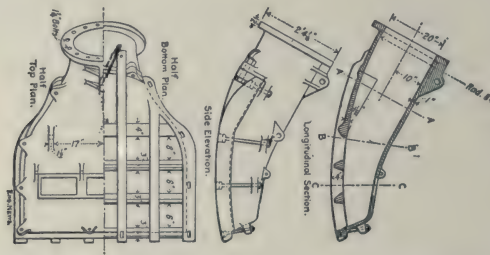

FIG. 25.—Allen Scraper Used on the U. S. Dredge "Manhattan."

ings. The blades are for the purpose of slicing off or excavating the material and feeding it into the interior of the shell through the openings, whence it is drawn into the pump. The efficiency of a cutter depends on the form of the blades, the angles at which they are set and whether they are straight or spiral, and on the openings between them and at the bottom. It would be almost impossible to determine absolutely the best form of cutter suitable for any material. According to the experience of Mr. James H. Apjohn, M. Inst. C.E., a cutter with its straight knives set at an angle of 26° to the tangent of the circle round which they were placed and overlapping each other to a slight extent, worked very well in loamy soil, but when the clay was reached the openings between the blades of the cutter clogged with the tenacious, plastic clay, with the result that the proportion of clay found in water discharged through the pipe line was extremely small. Another cutter with

narrow spiral knives used on the same dredge proved to be more efficient in clay than the first one. The effect of the cutters of working in sand was to wear the blades to a considerable extent, but the bearings kept in good order, the sand being excluded from them by an arrangement by which they are lubricated by water under pressure. From Mr. Apjohn's experience it could be deduced that a cutter with spiral knives is more adaptable for soils hard and compact; while the straight blades seem very efficient in loose soils. The rotary motion of the cutter is imparted by gears and shaftings placed above the suction pipe and operated by special engines.

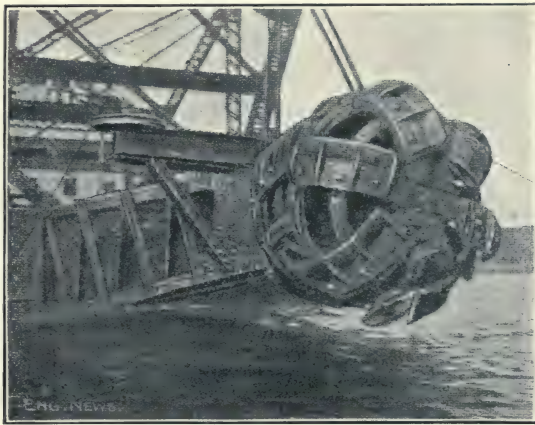

FIG. 26.—Rotary Cutter at the End of Suction Pipe.

Fig. 26 shows the rotary cutter at the end of the suction pipe of a hydraulic dredge.

On the Chicago Drainage Canal was employed a hydraulic dredge designed by Gen. William S. Smith of Chicago. This dredge was provided with a new device for loosening and mixing the material with water. Instead of a rotating cutter at the end of the suction pipe a series of hydraulic jets was used. A pump placed near the bow of the boat supplied water for the jets, which were controlled by hand, the nozzles being fastened to long poles. The jets loosened the muck effectively enough, but at the same time they forced the material away from the suction pipe, so that of the total volume pumped out only a small per cent was solid matter. Various means were tried in an effort to keep the muck near the

suction pipe, after being loosened by the jets, but without success.

For working in sand, water jets for breaking down the material to be dredged are preferred to rotary cutters by engineers on the Mississippi River. At first water jets 9 or 10 in number $2\frac{1}{2}$ to 3 in. in diameter with a pressure of 14 lbs. per sq.in. were used, but subsequently much better results were obtained by jets $1\frac{1}{2}$ in. in diameter, 6 in number, with a pressure of 65 lbs. per sq.in.

Instead of jets of water compressed air could be used for dislodging

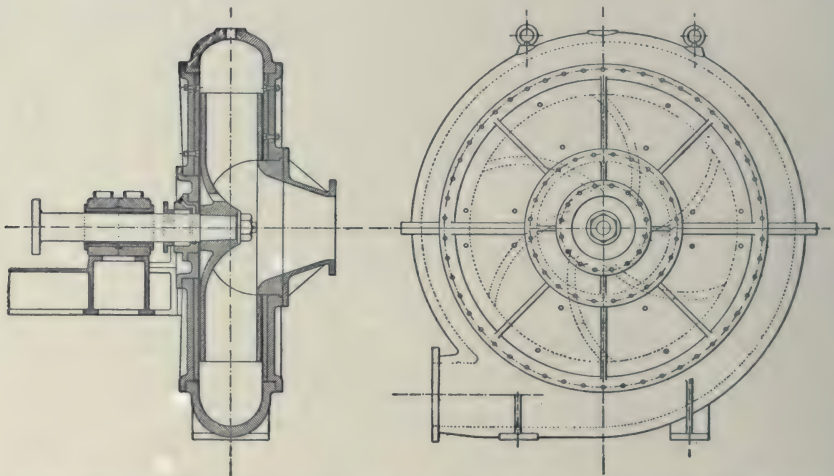

Figs. 27 and 28.—Cross-section and Side View of the Centrifugal Pump of a Hydraulic Dredge.

the material from the bottom, but the same objections exist against air jets.

Pump. The most essential part of the hydraulic dredge is the centrifugal pump. When the dredge is designed to work only through finely divided soils any pump of ordinary construction will be found satisfactory; but when the dredge operates through hard and compact soils special attention should be given to designing the shell of the pump, which should be strong enough to resist the violent blows caused by stones thrown against the inner surface of the shell by the impact of the flowing water and materials carried in suspension. The shell is usually made of cast steel or cast iron

cast in one piece of round cross section, the dimensions being determined by the required capacity of the dredge. Owing to the fact that the upper part of the shell tends to break, especially when dredging through hardpan and gravel, it is found more convenient to have the shell cast in two separate parts, bolted together so as to renew the upper part when damaged without being compelled to change the lower one. The runner or impeller consists of a cast-steel disk with four cast-steel vanes tapering in thickness and sharply curved in the back as shown in Figs. 27 and 28, which is an outline of one of the pumps used for sand dredging on the Mississippi River. The runners can also be made with 5 blades, as in the U. S. hydraulic dredge "Delta," or even with seven blades, as in dredge "Epsilon," used on the Mississippi River.

The pumps are often lined with steel plates for the purpose of removing the lining when damaged and substituting new plates. Mr. Robinson states that the delay and expense of renewing the linings amount to more than the occasional renewal of the entire pump shell, as the latter can be replaced in less time than the linings. Besides the bolts or fastenings of the linings tend to produce abrasion and wear at those particular points. Wherever there is a crack or joint in the interior of the pump it is liable to produce an eddy or change of direction in the flow, and a stream of gritty material acting in this way will soon cut out the fastenings and joints of the linings.

Mr. Robinson says that the interior wear of the pump can be greatly reduced by careful design. It is better to allow ample clearance for the flow at all points, especially the periphery of the pump, and this can be so proportioned that the abrasion is comparatively slight and evenly distributed. If experience shows that there is undue wear at one point, it means that there is a stream of gritty material flowing or impinging against the surfaces at that point and at a high velocity. This can be remedied by placing those surfaces further away, thus giving the stream more room at that point. Many pump designers are of opinion that the throat or cut-off of the interior of the pump should be as close as possible to the periphery of the pump runner in order to prevent any flow past this point. Careful experiments have shown that this makes very little difference, and for dredging pumps especially it is better to allow great clearances at this point, otherwise it will cause great wear.

The following table shows the amount of solid material that can be raised by pumps and the H.P. required:

TABLE NO. 1.

No. Pump (Diameter Discharge. Opening).	Diameter Suction.	Cubic Yards Material per Hour, 10 to 20 Per Cent of Solids.			Horse-power Required for Each 10 Feet. Elevation.
		10 Per Cent.	15 Per Cent.	20 Per Cent.	
4	4	14	21	28	4
6	6	30	45	60	8
8	8	60	90	120	15
10	10	90	135	180	25
12	12	125	190	250	30
15	15	210	315	420	50
18	18	300	450	600	70
20	20	360	540	720	80
24	24	480	700	960	100
32	32	900	1350	1800	200
36	36	1140	1710	2280	250
48	48	2040	3220	4080	450

Mr. A. W. Robinson states, "The efficiency of a good centrifugal pump for water is from 55 to 65 per cent under ordinary conditions; that of a dredging pump is from 48 to 55 per cent."

Table No. 2 gives revolutions of various kinds of centrifugal pumps, while Table No. 3 gives the capacity of dredging pumps. All of the tables in this chapter are taken from the catalogue of the Morris Machine Works of Baldwinsville, N. Y., builders of centrifugal pumps.

Discharge Pipes. Discharge pipes are of the same material and dimensions of those composing the suction pipe. The discharge pipes generally rise vertically from the pump and then bend toward the point of discharge. When the suction dredge is of the hopper type the discharge pipes run into the sand bins, otherwise they are turning toward one side of the vessel in order to be emptied into scows to be placed alongside of the vessel. But with the suction dredges which are not of the hopper type, the most convenient way of disposing of the débris is to fill up lowlands along the shores and in such cases the discharge pipe is connected with a long line of pipe placed on floats, thus conveying the dredged materials to distant points.

The velocity of flow in the discharge pipe varies from 8 to 16 ft.

TABLE No. 2

REFERS TO SPEEDS AT WHICH VERTICAL PUMPS, STANDARD PUMPS, COMPOSITION PUMPS, AND DOUBLE-SUCTION PUMPS SHOULD RUN TO RAISE WATER TO DIFFERENT HEIGHTS

No.	5 Feet.	10 Feet.	15 Feet.	20 Feet.	25 Feet.	30 Feet.	35 Feet.
1½	428	604	739	854	955	1045	1131
1¾	348	491	601	695	777	850	920
2	272	384	472	545	607	665	720
2½	272	384	472	545	607	665	720
3	272	384	472	545	607	665	720
4	230	364	447	515	574	630	680
5	206	289	354	410	457	500	541
6	172	242	295	341	381	418	452
8	148	207	250	293	327	359	387
10	135	190	233	270	300	329	355
12	107	151	185	213	238	261	282
12*	206	289	354	410	457	500	541
15	83	116	142	164	183	201	217
15*	121	171	209	241	270	295	319
18	83	116	142	164	183	201	217
18*	121	171	209	241	270	295	319
20	115	162	197	228	255	280	302
24*	104	146	178	206	230	253	272
24	77	108	132	152	170	187	201

No.	40 Feet.	50 Feet.	60 Feet.	70 Feet.	80 Feet.	90 Feet.	100 Feet.
1½	1208	1351	1481	1599	1714	1813	1911
1¾	982	1099	1205	1301	1394	1475	1554
2	773	858	940	1030	1085	1150	1215
2½	773	858	940	1030	1085	1150	1215
3	773	858	940	1030	1085	1150	1215
4	727	812	890	960	1025	1085	1145
5	579	647	712	765	817	867	914
6	483	540	591	638	683	722	763
8	415	464	510	548	586	620	655
10	380	425	467	502	538	568	600
12	302	337	371	400	436	452	476
12*	579	647	712	765	817	867	914
15	232	259	286	307	328	348	368
15*	342	382	420	451	483	511	539
18	232	259	286	307	328	348	368
18*	342	382	420	451	483	511	539
20	323	361	395	426	456	483	510
24*	291	326	358	384	412	436	459
24	215	241	263	284	304	322	340

* Refers to low-lift pumps.

If pumps are run at above speeds they will deliver quantities of water stated in Table No. 3. If water is to be forced through long pipes or through many elbows, speed must be increased to correspond. The above pumps can all raise water 100 ft., but should be made extra heavy for elevations above 60 ft., and for best results high-pressure type of pumps should be used.

TABLE NO. 3

CAPACITY IN GALLONS PER MINUTE DISCHARGED AT VELOCITIES IN FEET PER SECOND, FROM 3 TO 15. ALSO FRICTION HEAD IN FEET PER 100 FEET LENGTH OF PIPE.

Diam. Pipe.	1-inch.		2-inch.		3-inch.		4-inch.		Diam. Pipe.
	Capacity.	Friction.	Capacity.	Friction.	Capacity.	Friction.	Capacity.	Friction.	
3	7.34	4.08	29.37	2.04	66.09	1.36	117.50	1.02	3
4	9.79	6.83	39.16	3.41	88.12	2.27	156.67	1.71	4
5	12.24	10.2	48.95	5.12	110.15	3.41	195.70	2.56	5
6	14.68	14.3	58.74	7.16	132.18	4.78	235.84	3.58	6
7	17.13	19.0	68.53	9.54	154.21	6.36	274.98	4.77	7
8	19.58	24.5	78.32	12.2	176.24	8.16	314.12	6.12	8
8½	20.80	27.4	83.23	13.7	187.25	9.15	333.75	6.86	8½
9	22.03	30.5	88.11	15.2	198.27	10.1	352.26	7.64	9
9½	23.25	33.8	93.00	16.9	209.24	11.2	371.90	8.46	9½
10	24.48	37.3	97.90	18.6	220.30	12.4	391.40	9.33	10
10½	25.70	40.9	102.80	20.4	231.31	13.6	411.05	10.2	10½
11	26.92	44.7	107.69	22.3	242.33	14.9	430.54	11.1	11
11½	28.15	48.7	112.58	24.3	253.34	16.2	450.20	12.1	11½
12	29.37	52.8	117.48	26.4	264.36	17.6	470.68	13.2	12
13	31.82	61.5	127.27	30.7	286.39	20.5	509.82	15.3	13
14	34.27	71.0	137.06	35.5	308.42	23.7	548.96	17.7	14
15	36.72	81.0	146.85	40.5	330.45	27.0	587.10	20.3	15

Diam. Pipe.	5-inch.		6-inch.		7-inch.		8-inch.		Diam. Pipe.
	Capacity.	Friction.	Capacity.	Friction.	Capacity.	Friction.	Capacity.	Friction.	
3	183.63	.816	264.24	.68	359.79	.583	470.04	.510	3
4	244.84	1.36	352.32	1.13	479.72	.976	626.72	.854	4
5	306.05	2.05	440.40	1.70	599.65	1.46	783.40	1.28	5
6	367.26	2.86	528.48	2.38	719.58	2.05	940.08	1.79	6
7	428.47	3.81	616.56	3.18	839.51	2.72	1096.7	2.38	7
8	489.68	4.90	705.64	4.08	959.44	3.49	1253.4	3.06	8
8½	520.61	5.49	749.01	4.57	1019.4	3.92	1331.5	3.43	8½
9	550.89	6.11	793.72	5.09	1079.4	4.36	1410.1	3.82	9
9½	581.25	6.77	837.08	5.61	1139.4	4.83	1488.0	4.23	9½
10	612.10	7.46	881.80	6.21	1199.3	5.33	1566.8	4.66	10
10½	642.43	8.19	925.20	6.82	1259.3	5.84	1645.8	5.22	10½
11	673.31	8.95	969.88	7.45	1319.2	6.39	1723.5	5.59	11
11½	703.62	9.74	1013.3	8.11	1379.2	6.95	1801.5	6.08	11½
12	734.52	10.5	1057.9	8.80	1439.2	7.54	1880.2	6.60	12
13	795.73	12.3	1145.0	10.2	1559.1	8.79	2036.8	7.00	13
14	856.94	14.2	1233.1	11.8	1679.0	10.1	2193.5	8.87	14
15	918.15	16.2	1321.2	13.5	1799.0	11.6	2350.2	10.1	15

Diam. Pipe.	9-inch.		10-inch.		12-inch.		14-inch.		Diam. Pipe.
	Capacity.	Friction.	Capacity.	Friction.	Capacity.	Friction.	Capacity.	Friction.	
3	504.78	.453	734.40	.408	1057.5	.347	1439.0	.291	3
4	793.04	.759	979.20	.683	1410.0	.581	1919.7	.488	4
5	991.30	1.13	1224.0	1.02	1762.6	.871	2399.4	.731	5
6	1189.5	1.59	1468.8	1.43	2115.1	1.21	2878.0	1.02	6
7	1388.8	2.12	1713.6	1.90	2467.6	1.62	3358.7	1.36	7
8	1588.0	2.72	1958.4	2.45	2820.1	2.08	3838.4	1.75	8
8½	1685.0	3.05	2080.8	2.74	2996.3	2.33	4078.3	1.96	8½
9	1784.3	3.40	2203.2	3.05	3172.7	2.60	4318.1	2.18	9
9½	1883.5	3.76	2325.6	3.38	3348.9	2.88	4558.0	2.42	9½
10	1982.6	4.14	2448.0	3.73	3525.2	3.17	4798.0	2.66	10
10½	2082.7	4.55	2570.8	4.09	3701.4	3.48	5037.7	2.92	10½
11	2181.9	4.97	2692.8	4.47	3877.7	3.80	5277.5	3.19	11
11½	2280.0	5.41	2815.2	4.87	4053.8	4.14	5517.4	3.48	11½
12	2279.1	5.87	2937.6	5.28	4230.2	4.49	5757.2	3.77	12
13	2577.4	6.84	3182.4	6.15	4582.8	5.23	6237.8	4.40	13
14	2776.6	7.88	3427.2	7.10	4935.4	6.03	6717.5	5.06	14
15	2974.9	9.00	3672.0	8.10	5287.8	6.89	7107.2	5.79	15

TABLE NO. 3

CAPACITY IN GALLONS PER MINUTE DISCHARGED—Continued

Diam. Pipe.	15-inch.		18-inch.		20-inch.		22-inch.		Diam. Pipe.
	Capacity.	Friction.	Capacity.	Friction.	Capacity.	Friction.	Capacity.	Friction.	
3	1652.2	.272	2379.7	.227	2937	.204	3554.1	.185	3
4	2203.0	.455	3172.6	.379	3916	.342	4739.8	.310	4
5	2754.7	.682	3965.5	.569	4896	.512	5924.5	.465	5
6	3304.4	.955	4758.4	.795	5875	.717	7108.2	.651	6
7	3855.2	1.27	5552.3	1.06	6854	.954	8293.9	.866	7
8	4406.9	1.63	6345.2	1.36	7833	1.22	9478.6	1.11	8
8½	4688.1	1.82	6741.9	1.52	8323.6	1.37	10071	1.25	8½
9	4957.7	2.04	7138.1	1.70	8812	1.53	10663	1.39	9
9½	5232.1	2.25	7534.8	1.88	9302.6	1.69	11255	1.54	9½
10	5508.4	2.50	7931.0	2.07	9792	1.87	11848	1.69	10
10½	5783.4	2.73	8328.8	2.27	10281	2.05	12440	1.86	10½
11	6058.2	2.98	8724.9	2.48	10771	2.24	13033	2.03	11
11½	6334.6	3.25	9121.7	2.70	11258	2.43	13625	2.21	11½
12	6609.9	3.52	9517.8	2.93	11750	2.64	14217	2.40	12
13	7160.6	4.10	10310	3.42	12729	3.08	15402	2.79	13
14	7711.4	4.73	11104	3.93	13708	3.55	16587	3.22	14
15	8262	5.40	11897	4.50	14688	4.05	17772	3.68	15

Diam. Pipe.	24-inch.		26-inch.		28-inch.		30-inch.		Diam. Pipe.
	Capacity.	Friction.	Capacity.	Friction.	Capacity.	Friction.	Capacity.	Friction.	
3	4230.3	.170	4964.2	.157	5757.2	.146	6609	.136	3
4	5640.0	.284	6619.0	.262	7676.2	.244	8812	.227	4
5	7050.8	.426	8274.7	.394	9596.3	.366	11015	.341	5
6	8460.6	.597	9929.5	.550	11514	.512	13218	.478	6
7	9870.3	.794	11583	.753	13434	.681	15421	.636	7
8	11280	1.01	13238	.940	15353	.875	17624	.816	8
8½	11985	1.14	14066	1.05	16316	.980	18725	.915	8½
9	12690	1.27	14893	1.17	17273	1.09	19827	1.01	9
9½	13395	1.40	15721	1.30	18231	1.21	20928	1.12	9½
10	14100	1.55	16548	1.43	19192	1.33	22030	1.24	10
10½	14805	1.70	17375	1.57	20150	1.46	23131	1.36	10½
11	15510	1.86	18202	1.72	21111	1.60	24233	1.49	11
11½	16215	2.03	19029	1.87	22069	1.74	25338	1.62	11½
12	16920	2.20	19857	2.03	23030	1.89	26436	1.76	12
13	18330	2.56	21511	2.36	24950	2.20	28639	2.05	13
14	19740	2.95	23166	2.73	26869	2.53	30842	2.37	14
15	21150	3.37	24824	3.11	28788	2.80	33045	2.70	15

Diam. Pipe.	32-inch.		36-inch.		42-inch.		48-inch.		Diam. Pipe.
	Capacity.	Friction.	Capacity.	Friction.	Capacity.	Friction.	Capacity.	Friction.	
3	7519.7	.127	9518	.113	12954	.097	16921	.085	3
4	10026	.213	12690	.189	17272	.163	22561	.143	4
5	12532	.320	15863	.284	21590	.244	28201	.213	5
6	15039	.447	19036	.397	25908	.341	33841	.298	6
7	17546	.591	22208	.528	30226	.454	39482	.397	7
8	20052	.764	25381	.679	34544	.583	45122	.510	8
8½	21306	.857	26967	.760	36704	.653	47942	.571	8½
9	22559	.954	28554	.847	38863	.728	50762	.636	9
9½	23812	1.06	30140	.938	41022	.806	53582	.694	9½
10	25065	1.16	31726	1.03	43181	.888	56403	.778	10
10½	26319	1.28	33313	1.13	45340	.975	59223	.851	10½
11	27572	1.40	34899	1.16	47499	1.06	62043	.930	11
11½	28825	1.52	36485	1.35	49658	1.16	64863	1.00	11½
12	30379	1.65	38072	1.46	51817	1.26	67683	1.10	12
13	32585	1.92	41244	1.70	56135	1.46	73324	1.28	13
14	35092	2.21	44417	1.97	60453	1.69	78964	1.48	14
15	37598	2.53	47590	2.24	64771	1.93	84604	1.69	15

per second, and different kinds of material require different velocities of flow for the most efficient work. Material like clay or soft mud can be transported at a slower velocity than sand or gravel materials, which tend to precipitate quickly. A high velocity of flow means a greater friction in the pipe and pump and consequently greater expenditure of power. A fluid mixture of sand or mud and water is heavier than water alone, and therefore takes more power to pump it against a given head, and also the friction in the pipe is greater.

European engineers call the hydraulic dredges, suction dredges; but Mr. Robinson advocates calling them hydraulic, from the fact that the suction principle is not employed at all in dredging, but simply in conveying the débris from the bottom to the discharge. Such an explanation is necessary in order to prevent confusion in quoting from Engineering and other European papers, in which these machines are described under the head of suction dredges.

In hydraulic dredges a very large volume of water is pumped in connection with the material, consequently a large percentage of the power is wasted in useless work. They are therefore subjected to the same criticism as the high-tower ladder dredges. But also there the consideration of the economical disposal of the dredged materials will show in the end that they are not as wasteful as they appear at first. In fact the débris can be conveyed to a great distance by the simple action of the pump, and the large quantity of water carrying in suspension the débris allows the even deposit of the materials over a large surface. Besides, the suction dredge working continuously day and night is found to be both efficient and economical, more so than other types of dredges.

Hydraulic dredges can be grouped into sea-going and those used for channel or river improvements; the latter group can be divided according to Mr. Robinson in regard to their feedings as follows:

- (a) Lateral feeding or ship-channel type with floating discharging pipe.
- (b) Forward feeding or Mississippi type with floating discharging pipe.
- (c) Radial feeding with spud anchorage and floating discharging pipe.

These different types of hydraulic dredges will be described in the following chapters.

CHAPTER XIV

SEA-GOING HYDRAULIC DREDGES

SEA-GOING hydraulic dredges are of two types, those in which the hull is built like that of any ordinary steamer, having on board all the required machinery and accommodation for the crew, and those in which the hull is of larger dimensions to provide room for the hopper to store the excavated material. The former type of dredge is simply an excavating machine, while the latter type can be considered as an excavating and transporting machine. Considering these two types of dredges from the point of view of excavation, they are identical, the only difference being that in one case the débris is conveyed into the hoppers by means of a chute, while in the other case the chute conveys the materials to the sides so as to be loaded into scows. To avoid a useless repetition only the hydraulic dredges of the hopper type will be discussed.

The sea-going hydraulic hopper dredges perform the double function of dredging and transporting the débris so as to be dumped in convenient places, into deep waters. In order to unload the débris away from the shore so that the tides will not bring back any part of it, the steamers generally go not less than 8 or 10 miles from shore. For this reason their hulls must be strongly built to stand well in any kind of rough weather. The hull is usually built of steel, but there are several suction dredges used by the U. S. Government for harbor and river improvements along the Atlantic and Gulf coasts that have wooden hulls covered with copper plates. Wooden hulls are preferred on work at shallow depths on account of wood being more elastic than steel, the wooden dredge being better able to resist the inevitable pounding on shallow bars. Hulls are built of large dimensions in order to have large space for the hoppers, thus carrying on each trip as much as possible of the dredged materials. Yet these dimensions should be kept within certain limits so as not to require extra heavy and expensive engines, which tend to greatly increase both the original cost of the dredge and

its running expenses. Thus the capacity of the hoppers is kept between 2000 and 3000 cu.yds. The hull is divided in different compartments separated by watertight bulkheads.

The hopper for the reception of the dredged materials is constructed in different manner. It generally consists of two rows of bins located amidship on each side of the vessel in order to leave the pit in their middle for the suction pipe as in the dredge "Thomas," or they are simply located side by side divided longitudinally as in the dredge for the Seine River hereafter illustrated. The hoppers can also be located one forward and the other aft of the vessel, separated amidship by the space for the boilers and engines, as in the dredges "Manhattan" and "Atlantic." In such cases the hopper, being as wide as the vessel, must be well braced and strongly built to resist the pressure of the wet materials upon the walls of the wide hopper. The bottom of the hopper is generally made in the shape of several inverted frustra of pyramids for the purpose of facilitating the descent of the materials by sliding along the walls of these pyramids. The floor of each frustrum is formed by a gate or valve which can be opened at will. These gates or valves are built of various designs, the one most commonly used being in the shape of a flap hinged at one side to the hull and operated by a chain at the free end. The chains are attached to a horizontal shaft placed on deck and revolved by a system of cog-wheels moved by an engine. By revolving this shaft all the chains are drawn in or payed out, thus opening and closing simultaneously all the various compartments of the hopper. Conical valves are also used to close up the bottom of the various compartments of the hopper. In such a case the four walls of the inverted frustrum of the pyramid converges toward the bottom and end in a circle strongly reinforced with iron rings. Into these rings fit heavy conical shaped valves, and the various compartments of the hopper are opened or closed by simply raising or lowering these valves. The operation of dumping can be done while the vessel is in motion.

The materials removed from the bottom by hydraulic dredges are always mixed with a large quantity of water in such a way that the hopper will be found filled up with more water than solid materials. To avoid this the hoppers are always provided with several overflows, to carry off the water.

Besides hydraulic dredges with hoppers able to unload their contents by gravity in the manner just described, there have also

been constructed hydraulic dredges in which the materials stored in the hoppers can be transported to some point distant from the vessel by means of pumping through a pipe line. In such a case the bottom of the hopper is constructed in a different manner. This new method was introduced in the dredge "Nereus," built by Messrs. Smit & Sons for the removal of the bar of the Liffey in connection with the improvements of Dublin Harbor.

In the hydraulic hopper dredge "Nereus" the bottom of the hopper is formed by two sets of flaps, Fig. 29; one of these open in the usual way, being hinged to one side and controlled by chains on the opposite end. At some distance above these flaps

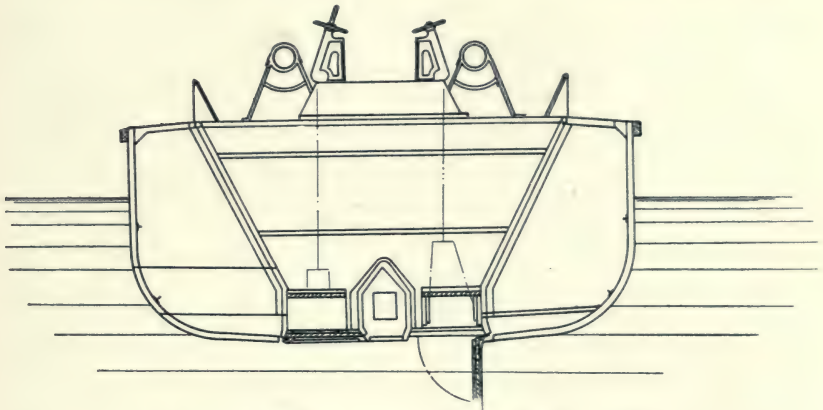

FIG. 29.—Hoppers in the Hydraulic Dredge "Nereus."

there are others which form the real bottom of the hopper. The space between these two sets of flaps forms a chamber which can be filled with water and for this purpose holes are left at the bottom of the chamber. Water can be also supplied to the chamber by means of a special tank located on deck. When the dredge is operated as any ordinary hopper dredge the upper set of flaps are left open and the débris will fill the chamber abutting directly against the large flaps, and are dumped in the usual way by simply opening these flaps. But when the dredge must transport the débris to distant points and then pump it to land by means of a discharge pipe the operation is made in a different way. The small flaps are closed and form the floor of the hopper. The large flaps are closed also and the chamber is filled with water

entering from the holes. In this manner the materials stored in the hoppers can be transported to any place. To dump the débris one set of small flaps is open at a time; the contents of the compartment of the hopper will fall into the chamber and the material mixed with water will be in condition to be raised by a sand pump. This pump will also force the material through a discharge pipe, thus conveying the débris to land. In case the quantity of water entering from the holes is not sufficient to dilute the material, water is taken from the tank on deck.

In regard to the dredging apparatus the hydraulic hopper dredges can be built either with a single suction pipe and a centrifugal pump located amidship, when the hull is provided with a well for the suction pipe like in the dredge "Thomas"; or the dredge is constructed with two centrifugal pumps, one located on each side

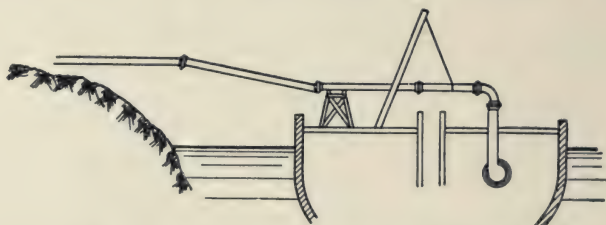

FIG. 30.—Sand Pump on Dredge "Nereus."

of the vessel and alimented by a suction pipe, each pump discharging into a separate hopper. In this manner are built the dredges for the Seine River and those of the U. S. Government employed in the Ambrose Channel in New York Harbor. The ends of the suction pipes may be furnished with either a simple grating or an excavator of the drag or cutter type. When there is only a grating or a drag the suction pipe is inclined toward the stern, while when there is an excavator the suction pipe is feeding forward and is inclined toward the bow. Since the hydraulic hopper dredge is usually designed to work in places exposed to stormy weather and on account of its great running expenses it must work even in heavy seas, special attention should be given to the joint of the suction pipe of the pump in order that the dredging be not affected by the rolling of the vessel and without straining the joint to such an extent as to impair its safety.

From the reason that the dredging operations should be con-

tinued during heavy seas the pump should be so designed as to be able to fill the hopper in the shortest time possible. As a rule it takes from 40 to 50 minutes to fill the hoppers of the capacity indicated above.

Several engines are required for the service of the sea-going suction hopper dredges, the most important being those for the purpose of propelling, pumping, lighting, steering, hoisting both the suction pipes and the anchors, opening the gates of the hoppers, etc. This kind of dredge being always in motion, should be provided with powerful propelling engines which will insure to the vessel a speed of at least 7 knots per hour when loaded and not less than 10 knots when light. Each pump is furnished power by an engine of the marine type with vertical cylinders and so designed as to overcome 100 ft. of head of water and causing the runners to make from 200 to 300 revolutions per minute. Electricity for the ordinary illumination of the vessel as well as for the arc lamps used on deck during the night work and for the searchlights is provided by a high-speed engine belted to a dynamo. The hoisting engines for lifting the suction pipes and the anchors are of the usual duplex type with two horizontal cylinders. Similar engines are used for the opening and closing of the gates of the hoppers when no other methods are used, and the steering is also done by a small steam engine. Steam is provided by marine boilers of sufficient capacity for the working of all the various engines simultaneously.

The manner of working with the sea-going hydraulic hopper dredges is as follows: When the dredge has reached the site of excavation the suction pipes are lowered until the drags or cutters reach the bottom and then the steamer moves ahead at a slow speed while the pumps are put in action. In this manner one or two furrows are dug on the bottom according to the number of suction pipes, along the course of the steamer, the width and depth of these furrows depending upon the device used at the end of the suction pipe. Mr. Babcock states that the U. S. dredges in New York Harbor are each provided with two drags 5 ft. wide and located 52 ft. apart. Two furrows are thus excavated, taking in a load of 2500 cu.yds., approximately 1800 cu.yds. in place, in a course 15,000 to 20,000 ft. long. The courses were laid out of such a length that the dredge could get a full load in going up and back once. This made a shorter trip to the dump and saved time by

avoiding unnecessary turns. The dredges began to work at 5 A.M. on Monday and did not return to the docks until Saturday at noon, working continuously day and night, stopping only for holidays or repairs. The efficiency of the work at night was estimated at 90 per cent of that done in daytime.

As previously stated, Gen. Gillmore used the hydraulic dredge of the hopper type in 1871, thus the honor of first using this type belongs to the United States. The following description is slightly condensed from a paper by Gen. Gillmore and published in *Van Nostrand's Magazine*, September, 1872:

A novel device, he says, for utilizing the powers of the centrifugal pump, has recently been put in successful operation by the writer, in deepening the channel over the bar at the mouth of the St. John's River, Florida. Upon this bar the ocean swell, which constantly prevails, is of such exceptional magnitude and violence that the usual method of dredging into lighters or scows, ordinarily pursued in still water, is entirely impracticable.

After futile attempts to get the bar channel deepened by contract, the following plan was adopted, viz.: To provide a suitable steamer and fit her out with a 9-in. centrifugal pump, two branches of 6-in. suction pipe, and timber bins on deck for holding the sand pumped up from the bottom.

The steamer used, the "Henry Burden," was originally built for carrying passengers and light freight, is 132 ft. long, 24½ ft. beam with a draft of 5½ ft. and carried only 100 tons on a draft of 7 ft. She is a side-wheel steamer with engines of 120 H.P., and although the best that could be found at that time yet she is not exactly adapted to the work required of her, on account of her comparatively deep draft and small carrying capacity, which rendered it impossible to prosecute work the during periods of low water.

A No. 9 centrifugal drainage pump of the Andrews patent is located on the main deck aft, about 35 ft. from the stern post. Its suction and discharge openings are each 9-in. in diameter. To the suction there are connected by a 2-way branch pipe two 6-in. suction pipes, instead of one 9 in. as usual, the object being not only to work on both sides of the boat simultaneously, but to make the necessary handling of the pipes as easy and prompt as possible.

The engine used to drive the pump consists of two cylinders connected upon one crank, at right angles to one another, and 10 in. in diameter, each with a 10-in. stroke. Steam is conveyed from

the boiler to the pump engine through a 3-in. iron pipe, the usual pressure carried upon the boiler being about 25 lbs. to the sq.in.

This pressure develops about 26 useful horse power and gives a speed of about 180 revolutions per minute to the engine shaft. On this shaft is a pulley 42 in. in diameter, carrying a rubber belt 12 in. wide, communicating the power to the pump shaft through a pulley 24 in. in diameter, thus giving the pump disk and wings about 315 revolutions per minute. This speed with the No. 9 pump is equal to the work of raising 3000 gallons of clear water per minute 30 ft. high through a 9-in. vertical pipe. The actual height raised above the water on the St. John's bar varies with the amount of sand taken on board from 10 to 11 ft. Owing to the facts that the pipes are 50 ft. long with bends, are in two branches instead of one and as the mixture of sand and water is heavier and more impeded by friction than clear water, 300 revolutions are required to raise 2500 gallons of sand and water 11 ft. high through the two inclined suction pipes having two turns each, discharging through a pipe having one turn.

To prevent the ends of the suction pipes being lifted off the bottom by the pitching of the boat, and, as a precaution against accident, a portion of each pipe is made flexible, being composed of 6-in. rubber hose stretched over a coil of wire. In addition, the ends are loaded with an iron frame or drag, each weighing about 250 lbs., which is intended to move flat along the bottom during the operation of dredging. To the under-surface of this frame, directly below the mouth of the pipe, a number of teeth or knives are attached to stir up the sand and aid its entrance into the pipes.

Tackles are arranged for lifting the pipes from the bottom when not dredging, or when pumping clear water to discharge the sand from the bins.

For receiving the sand, bins are located along the main deck, fore and aft, on each side of the steamer's engine, each bin being provided with a sliding gate over the steamer's side, which can be opened and closed at pleasure. The bottom of the bin slopes downward toward the gates. They are filled from two open troughs, one from each branch of the discharge pipe, provided at suitable intervals with valves or gates so that the load can be distributed to the bins wherever desired.

Including the time occupied in turning the boat and emptying the bins, the least average result of an entire month's work was

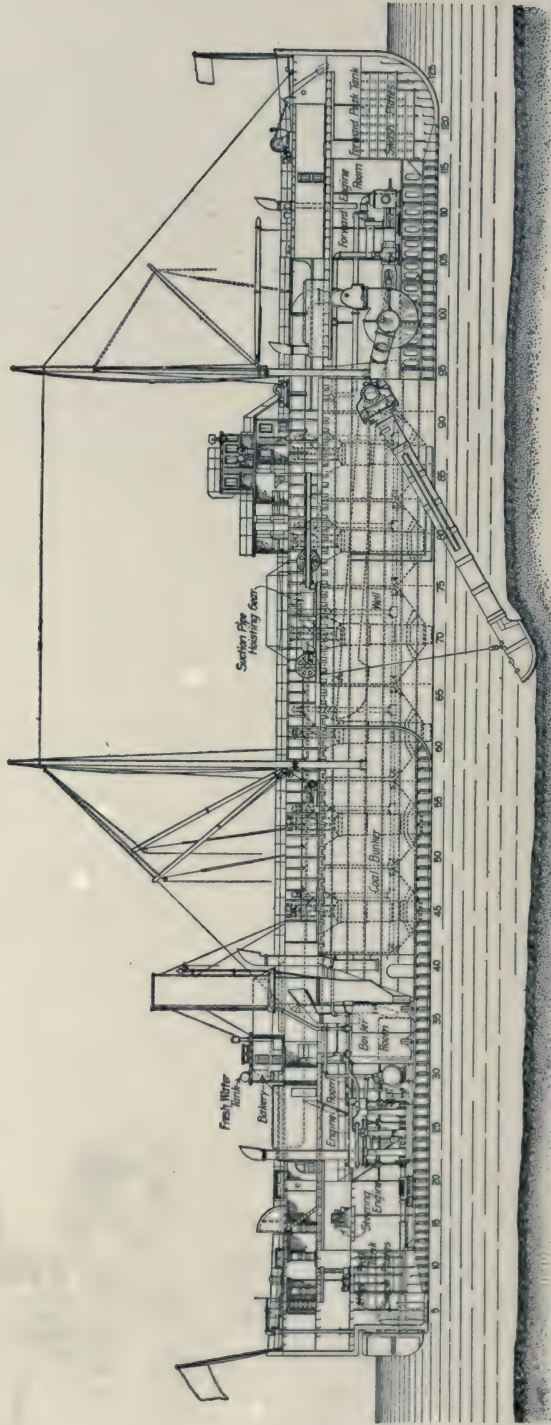

Longitudinal Section.
Fig. 31.—Dredge "Thomas,"

in November, 1871, during which period .734 of a cu.yd. of sand per minute was removed. During the month of February, 1872, 1.127 cu.yds. per minute were removed. The greatest quantity removed on any one day was 770 cu.yds. or at the rate of 1.26 cu.yds. per minute.

The average cost of dredging and dumping the sand for the whole

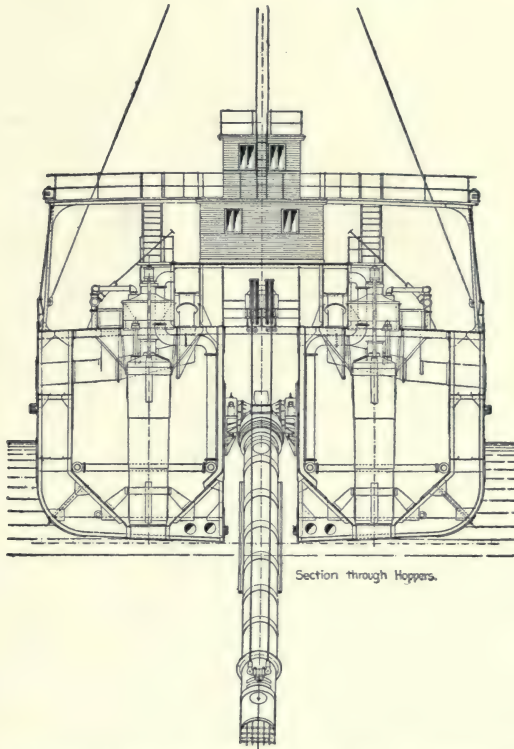

Fig. 32.—Cross-section of the Dredge "Thomas," showing Central Pit and Lateral Hoppers.

period of 7 months was $53\frac{1}{4}$ cents per cu.yd., the least cost during any entire week was 19 cents per cu.yd., and the least cost for any one day was on May 14, 1872, when 770 cu.yds. were removed in $10\frac{1}{8}$ hours, at a cost of only 13 cents per cu.yd., the time actually occupied in pumping being only $5\frac{3}{4}$ hours. With some modifications in the machines the cost of dredging would not exceed 10 or 11 cents per cu.yd. inclusive of running expenses, wear and tear of

machinery, and all stoppages for repairs and other contingencies. This cost would be greatly reduced in case the pump could work continuously, discharging directly to the dumping ground through either open troughs or pipes.

The following description of the dredge "Thomas," used by the Metropolitan Dredging Co. of New York, taken from *Engineering News*, Vol. XLV, illustrates a type of hydraulic dredge with two rows of parallel hoppers and a single suction pipe located in a well amidship. See Figs. 31 and 32.

This dredge is of 7000 tons displacement, 300 ft. long, 52 ft. 6 in. beam, 25 ft. molded depth, and has a hopper capacity of 2800 cu.yds. of material and a speed of 10 knots. As will be seen from the general plans, the hulls are of steel, and are provided with two decks. For about 125 ft. amidships the hull space below the main deck is taken up by a row of hoppers on each side, there being six hoppers in each row, two being 22½ ft. long by 18 ft. wide, and four being 20 ft. long by 18 ft. wide. The forward portion of the space between the two rows of hoppers is occupied by the well for the suction pipe. Aft of the hoppers the hull space below the main deck is given up to the main engine and boiler-room, propelling machinery and steering gear, and forward the corresponding space is devoted to the pump and pumping engines. The space between the main and upper decks is devoted chiefly to the quarters for the officers and men. The upper deck carries the derricks, windlasses and usual above-deck structures of a sea-going vessel. Taking up the description of the various parts named in more detail, we have first to consider the dredging machinery and hoppers.

The space forward of the hoppers, which is devoted to the dredging machinery, extends the full width of the vessel and for 50 ft. fore and aft. The main centrifugal pump is located in the center close to the forward end of the suction pipe well. It is a 48-in. pump built by the Morris Machine Works, of Baldwinsville, N. Y., and has two side pipes to the suction pipe and two discharge openings connected with separate discharge pipes leading to the two rows of hoppers, as shown by the drawings. This pump is operated by two tandem, compound 17×30×36-in. stroke cylinder engines, exhausting into condensers. The pump has a guaranteed capacity of 75,000 gallons of water per minute, and will operate under a resistance equal to about 40 ft. head of water. The centrifugal pumping engines are placed forward of the pump, and forward of them is a

large compound condensing duplex pump made by the Stilwell-Bierce & Smith-Vaile Co., of Dayton, O., for the water jets on the section drag and in the discharge valves of the hoppers. This pump has 18×30 in. steam and 24×24 in. water cylinders. Another duplex pump, with 6×18 in. plungers, capable of pumping against a pressure of 1000 lbs. per sq.in., is employed for operating the hydraulic cylinders by which the discharge valves in the hoppers are actuated and also for operating the hoists for raising the suction pipe.

The hoppers have rectangular bodies terminating in frustums of rectangular inverted pyramids at the bottoms. The discharge outlet in the bottom of each hopper is 4 ft. in diameter, and is closed by a trunk valve of the same diameter which extends up through the hopper and is raised and lowered by a 12-in. hydraulic cylinder. In operation this trunk valve is raised about 3 ft. to allow the contents of the hopper to discharge. To facilitate the discharge of these contents and to loosen them up so that the trunk valve may be easily hoisted, water is forced through the jets in the discharge valve by the pump previously mentioned. When the discharge is completed the centrifugal pump is started, forcing clear water through the discharge pipes and into perforated flushing pipes located in each hopper around the walls at a point where the vertical and inclined sides join. This operation cleanses the discharge pipes and the hoppers of all the undislodged contents.

The main boiler and engine-room contains two boilers 14 ft. in diameter and 11 ft. 10 in. long, operating under 180 lbs. steam pressure, and between the main boilers there is also a 7½×9 ft. donkey boiler. Aft of the boilers are located two inverted-cylinder, direct-acting, triple-expansion engines, with 18-, 25- and 48-in. cylinders, with 30-in. stroke. The high-pressure and intermediate cylinders have piston valves, and the low pressure cylinder has slide valves. These engines drive twin screws.

The operation of the dredge is as follows: The suction tube is lowered to the bottom and the air exhausted from the centrifugal pump by a 4-in. injector. When the pump is charged the pumping engines are started, filling the tanks with water. The suction pipe having fed itself into the bottom to a sufficient depth, the dredge is moved ahead at a speed of about 25 or 30 ft. per minute, until the hoppers are filled with dredgings. To loosen the material so that the suction can secure it, the water jets previously noted are kept in operation. When the hoppers are filled the suction pipe is

raised, and the dredge proceeds to sea, where it discharges its load by performing the series of operations previously described.

The fittings of the dredge are unusually complete throughout, and a particular attempt has been made to provide comfortable quarters for the officers and crew. These quarters, together with the messrooms, pantries, etc., are located above the main deck, as shown by the drawings, which also show in sufficient detail the above-deck structure and rigging.

The following description of a hydraulic dredge with two suction pipes and a central hopper is taken from *Engineering*, November 22, 1901.

The lower reach of the Seine, from Rouen to the open sea, had, until recently, been practically unused for maritime service, although it might have been made a first-class channel for commercial purposes. Navigation, as far as Rouen, was carried out under very great difficulties, owing to the varying nature of the water discharge and the changing depths. Up till 1848, of the 78 miles which separate Rouen from the sea, 37, at least, formed an estuary of exceedingly great width, useless in the point of view of navigation, the fairway being a shallow and very changeable one, in the midst of shifting sandbanks and mud. In the period from 1848 to 1866 a series of longitudinal dykes were built on both banks, the total developed length of which rapidly extended to over 40 miles; these gave good results in the sense that they deepened the channel at many places. From 1866 to 1885 no new work was carried out, and the maintenance in good state of repair of the dykes previously built—with unsuitable material—was very laborious. Since 1885 attempts have been made to improve the conditions of navigation up-stream from the Risle River, and the conditions of the estuary proper. The object is to regulate the distance between the opposite banks in such a way that the body of water available is the largest possible, dredging being resorted to in order to improve the flow and deepen the channel. In 1895 a powerful bucket dredge was put in service; this was found very efficient, in that it easily reduced to 3 ft. under the zero of the charts, beds that were formerly above zero. As soon, however, as an experimental suction dredge had been tried and found to give excellent results, the Seine Board of Works ordered three powerful ones of this system from the *Société des Anciens Etablissements Satre*, of Lyons, Arles, and Rouen.

There being very often rough weather on the Lower Seine,

and as there could be no question of putting the dredges in shelter when not in actual work, they had to be built seaworthy throughout. They, in fact, traveled under their own steam from Marseilles to Havre, having been built at Arles, in the south of France, and behaved perfectly well in the crossing. The central portion of the dredge in question is given in Fig. 33. The hull is divided into compartments by eight watertight bulkheads. The first compartment is the forepeak, used as a hold; the second one is the crew space, with berths for eight men. The next compartment contains the officers' cabins and one cabin for the Ponts and Chaussées engineer, who has charge of inspecting and supervising the work done. In the following compartments are the sand and mud wells, the normal capacity of which is 17,658 cu.ft., the maximum capacity being 20,483 cu.ft., when extension tops are put round the openings of the hoppers, which is possible in fine weather. The wells are seven in number, fitted with two pairs of doors or sluices. The next compartment forms the engine-room, and also contains the dredge pumps; the one next to it is the stokehold, with coal bunkers, the last one being the chain locker.

There are in each dredge two vertical compound engines, capable of developing together a total of 540 indicated horse-power at 150 revolutions. This type of engine has been built in large numbers by Messrs. Satre for various purposes. Their principal dimensions are the following:

Diameter of high-pressure cylinder.....	0.440 m. (17 $\frac{5}{16}$ in.)
Diameter of low-pressure cylinder.....	0.800 m. (31 $\frac{1}{2}$ in.)
Stroke.....	0.450 m. (17 $\frac{1}{16}$ in.)

They are surface-condensing; the condenser is placed horizontally, and forms part of the engine frame. The valves are easily accessible for inspection and maintenance in good working order. The engines are so arranged that they can readily be made to drive, together or separately, both the propellers or the pumps. The boilers are Belleville boilers, fitted with economizers of 2154 sq.ft. heating surface, with two donkey pumps, and with an air compressor of 8830 cu.ft. A fresh-water tank can supply the boilers during a continuous run of 75 hours; suitable apparatus are provided for filtering the feed-water taken from the drain-pipes and condensers.

Each dredge is driven by two propellers worked from the engine

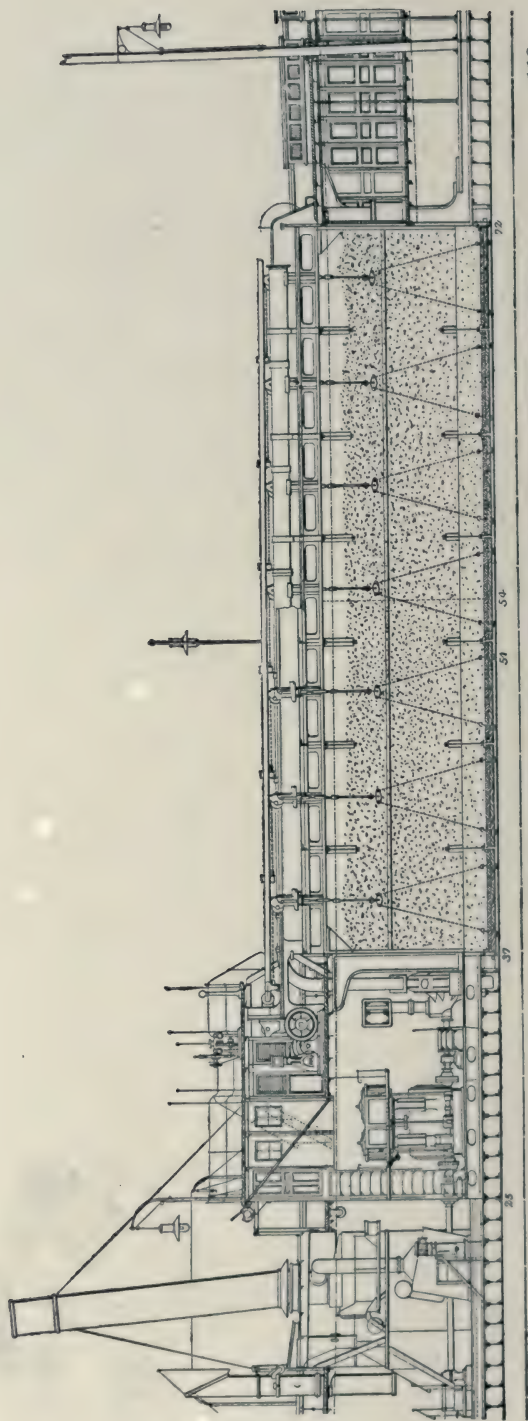

FIG. 33.—Central Portion of the Dredge "City of Rouen," showing the Single Hopper Amidship.

shafts through couplings. The propellers are independent one of the other, and can turn inversely, this being rather a novel feature for this kind of craft.

The dredging device consists of two centrifugal pumps worked from the main engine. The pump shells are cast in one piece, and provided with manholes for removing all obstructions when necessary. The suction turbines have four blades, and contain a special arrangement which prevents the sand from penetrating between the blades and the inside walls of the pump body. The door-pieces on the front part of the pumps carry the suction necks, which are connected, through an elbow that runs through the deck and a horizontal conduit, to another neck; the latter is fitted to the suction pipe through another elbow, a flexible length of tubing and a Hooke's joint. The suction pipe can draw sand from a depth of 43 ft. below water level, and can work even during a rolling swell of 91 in. The joint with the suction pipe being level with the deck, all work of maintenance and repair is easily carried out. The discharge from the pumps is effected through shoots, each with seven openings, provided with sluice doors to regulate the delivery on the dredge. Hoppers of perforated plates are provided in the sand wells.

Double steam winches are placed on deck at both ends; these are supplied with steam from an auxiliary boiler. Another steam winch serves to work the sluice valves and the suction pipe. The auxiliary boiler in question is multitubular, and supplies not only the winches, but also gives steam for the electric lighting of the boat and for heating the various berths. The electric-lighting equipment serves to facilitate night work; three arc lamps of 1000 candle-power each are provided on deck for this purpose.

These dredges give full satisfaction. They were to draw each 17,658 cu.ft. in 50 minutes; their traveling speed in a rolling swell of 15 in. was specified to be 8 knots, with a coal consumption of 1.87 lbs. per indicated horse-power per hour. During the tests the wells were filled in 38 minutes; the speed reached was $8\frac{1}{2}$ knots, with a coal consumption of 1.70 lbs. only.

CHAPTER XV

HYDRAULIC DREDGES FOR CHANNELS AND RIVER IMPROVEMENTS

THE hydraulic dredges used in the improvements of harbors and rivers usually discharge the dredged materials onto the nearby lands by means of long floating discharge pipe. These dredges,

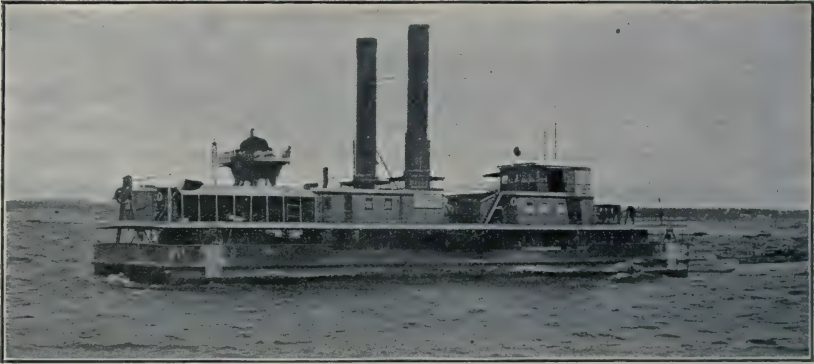

FIG. 34.—Dredge "J. Israel Tarte."

according to Mr. Robinson, can be divided into three groups, as follows:

- 1st. Lateral feeding.
- 2d. Forward feeding.
- 3d. Radial feeding.

Lateral Feeding. Possibly the only lateral-feeding hydraulic dredge is the "J. Israel Tarte" designed by Mr. A. W. Robinson for the improvement of the St. Lawrence River ship channel and described by himself in a paper read before the Canadian Society of Civil Engineers.

The hull of the dredges, Fig. 34 and 35, is of steel and is 160 ft. long, 42 ft. beam, 12 ft. 6 in. deep. The plating is $\frac{1}{2}$ in. thick on the bottom and $\frac{3}{8}$ in. on the sides with $\frac{5}{16}$ -in. deck. The hull is rounded

at the bilges, but it is rectangular in plan with rounded ends in side view. There is a central opening, or well, through which the suction pipe works. This well is 8 ft. wide except at the forward end, where it is 10 ft. wide to admit the cutter, and it is of sufficient length to receive the pipe. The suction pipe is formed of a rectangular steel box girder of great strength, and having its lower horizontal web extended in width so as to fit between the sides of the well. The flanges of this horizontal girder are formed of two angle irons $5 \times 5 \times \frac{1}{2}$ in. covered with a plate $12 \times \frac{3}{4}$ in., which bear against the sides of the

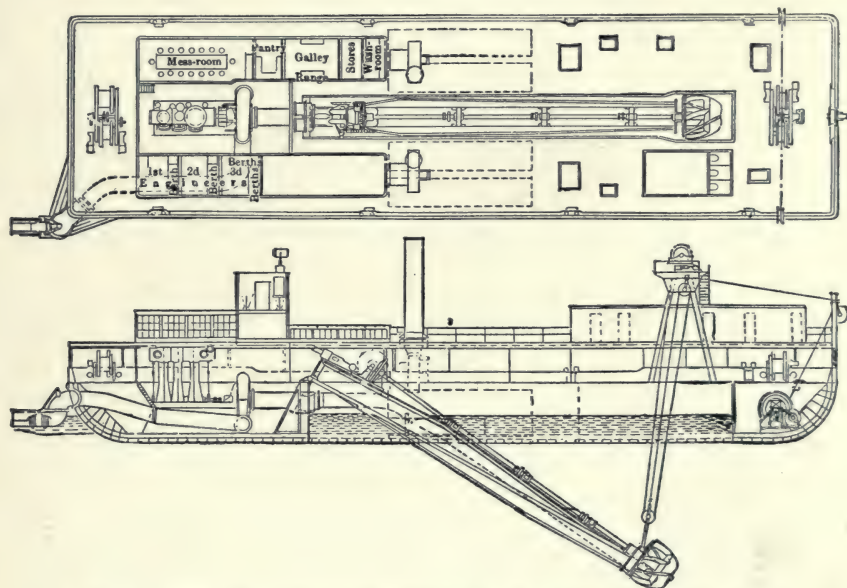

FIG. 35.—Plan and Longitudinal Section of the Dredge "J. Israel Tarte."

well. This is for the purpose of withstanding the great lateral strain due to feeding the dredge sideways and with the cutter in contact with the bottom. The suction pipe is hinged to the hull at the deck by means of massive steel hinged castings, and a steel bulkhead extends the entire width of the hull at this point. The sides of the hull are extended above the deck to form a solid steel bulwark entirely around the dredge, the hand-rail being formed of an 8-in. bulb angle finished on the outside with $2\frac{1}{2}$ in. half round. These bulwarks form a protection against the seas which sometimes break over the dredge.

The suction pipe is suspended from a double steel A frame over the forward end of the well, and the lifting winch for raising and lowering the suction pipe is carried on top of this frame.

The main engines are of the triple-expansion marine type, having cylinders 20, 31 and 50 in. in diameter with 25-in. strokes. They are adapted to run at 150 revolutions per minute.

The material is excavated by an improved rotary cutter (see



FIG. 36.—Floating Discharge Pipe of the Dredge "J. Israel Tarte."

Fig. 26), 9 ft. 6 in. diameter by 9 ft. long, the weight of which is 10 tons. It is formed of steel blades with especially designed clearance spaces between them, so as to avoid clogging with the material, and the suction pipe and passages through the pump are made very large for the same reason. The cutter is driven by a pair of engines placed on top of the suction pipe at the upper end. These engines are of the double tandem type of 300 I.H.P.; the gearing and power transmission for these engines is of exceptional strength and capable at all times of encountering immovable

resistances with full head of steam on the engines without risk of breakage. The main gearing driving the cutter is of cast steel 5 in. pitch and 5 in. face.

Steam is furnished by four boilers, having collectively 8500 sq.ft. of heating surface, and adapted for working pressures of 160 lbs. There is coal bunker capacity of 200 tons.

The main pump is of the centrifugal type, having cast-steel runners of inclosed type and heavy cast-iron shell. The blades of the runner and the heads of the pump are protected by renewable steel wearing plates in the shell. This shell is exceedingly heavy, so that it can stand a considerable amount of wear before it begins to fail, and it is also so designed that the stream of material issuing from the runner does not impinge to any extent upon it at any one point.

The entire operations of the dredge are controlled from the pilot-house on the upper deck. Here are located the levers for both the bow and stern anchorage winches and the lifting winch for the suction pipes; also a system of bells and signals to the engine room. The pilot-house is so placed that the operator has an unobstructed view up and down the river; also of the entire discharge-pipe (see Fig. 36).

The dredge is fitted with complete quarters for a double crew of 36 men, or 18 men on each shift. The dredge works continuously from Sunday night till Saturday night, without stopping except when necessary. The dredge is attended by a powerful light-draft twin-screw tug. The principal duty of this tug is to fleet the anchors as the dredge moves ahead. The side lines of the channel to be made are marked at night by temporary range lights.

The efficiency of the dredge "J. Israel Tarte" is estimated at 600,000 cu.yds. per month, although for short periods it has worked at the rate of 2600 cu.yds. per hour. The average cost per cu.yd. for the year is about $1\frac{3}{4}$ cents. This dredge was built by the Polson Iron Works of Toronto, Can., at a cost of \$163,800, excluding the discharge pipe and the winches, which were not designed when the contract was placed.

Forward Feeding. The second group of the hydraulic dredges employed in the improvements of channels and rivers are those provided with a forward feeder and extensively used on the Mississippi River. The following description of the "Delta" taken from a paper by Mr. Ockerson, will serve to illustrate this type of dredge.

The hull is of steel, 175 ft. long, 38 ft. wide, and $8\frac{1}{4}$ ft. deep.

The dredging pump is different from any other in the shape of the casing and the runner. The runner has five blades 22 in. wide, and is 7 ft. in diameter. The edges run close to the casing, but the runner is not concentric with the casing, hence the outer ends of the arms are nearer one side of the casing than the other, the widest space being at the bottom, and the space being nearly cut off by a projection in the casing at the upper side of the discharge opening. The axis of the pump is parallel to the axis of the boat and lies over the center line of the same. The shaft has one long bearing through the aft side of the casting, and is provided with water bushing under pressure to keep the sand out of the bearing. The sand pump is driven by a vertical, inverted, two-crank, compound-condensing engine, with cylinders 22 and 48 in. diameter and 24-in. stroke. It is fitted with a piston and slide valve and has an adjustable cut off for the piston valve. This engine was designed to develop 800 H.P. at 140 revolutions per minute, with a boiler pressure at 160 lbs. and a vacuum of 25 in.

The engine which drives the cutters is horizontal, two cylinder and non-reversible, attached to a sliding steel frame, which moves back and forth in guides as the cutter is raised or lowered. This is necessary because the shaft which drives the sprocket chain is not in the axis of motion on which the suction and cutter revolve. The whole engine, with its frame, follows the motion of the shaft, so that the gear and pinion are always engaged. To admit of this motion, the steam pipes are provided with slip joints. The cylinders of this engine are $12\frac{1}{4}$ in. in diameter and 15-in. stroke, with the locomotive type of slide valve.

There are two winding drums located forward of the sand pump, one on the starboard and the other on the port side of the hull. These drums are provided with clutches and brakes, and are driven by two independent double-cylinder, horizontal engines with cylinders 10×12 in.

The ladder hoist for raising and lowering the suction, and the spud hoist for raising the spud, each has drums 24×24 in. The cables from these drums lead to the roof and thence out through sheaves to the ladder and spud. These drums are operated by the same engines that operate the winding drums.

Steam is supplied by four Heine safety water-tube boilers rated at 250 H.P. each.

The intake of the sand pump is from one pipe 34 in. in diameter, entering in the axis of the pump at the forward side of the casing. This single pipe runs 25 ft. to the forward bulkhead and there branches into two pipes each $24\frac{1}{2}$ in. in diameter, which separate and pass through the bow of the boat below the water-line 9 ft. apart. These two pipes turn to the right and left along the outside of the bow and then turn forward again and each branch separates into two suction heads. The whole is framed together so that the four pipes, suction heads and cutters are raised and lowered together as one piece. Instead of a radial slipjoint for the suction pipes, as used on the other dredges, there is a vertical flanged joint in the horizontal part of each pipe next to the bow, and the revolving pins that sustain the weight of the aft end of the suction are placed in the prolonged axes of these pipes.

The cutter for loosening up the material is placed at the outer end of the suction head. It has 22 cast-steel wheel cutters, each having four blades mounted on a steel shaft $6\frac{7}{8}$ in. square. This shaft is driven by the cutter engine by means of two steel sprocket chains, at a rate of about eight revolutions per minute.

The floating discharge pipe is 1000 ft. long with the usual rubber couplings at intervals of 50 ft. There are pontoon floats on each side of this pipe U-shaped in section, with the flat side closed, and they sustain the pipes in yokes which are firmly attached to the floats. There is a baffle plate at the end of the pipe line. The dredge is provided with sixteen hydraulic piles, six of which are 10 in. in diameter and 38 ft. long, and ten are 6 in. in diameter and 25 ft. long.

This dredge was constructed under contract with the New York Dredging Co., which sublet the construction of different parts to various manufacturers and builders of machinery. The contract price for this dredge was \$124,940. The maximum efficiency of this dredge was found to be 3212 cu.yds. of sand per hour while the minimum was 928 cu.yds. per hour.

Radial Feeding. The last group of the hydraulic dredges used in the channel and river improvements are those with radial feeding and are illustrated here by the description of the dredge "King Edward VII," slightly condensed from a paper by Mr. A. W. Robinson, delivered before the Canadian Society of Civil Engineers.

The dredge "King Edward VII." is anchored by spuds and has a radial feed, the cutter describing an arc of a circle about the

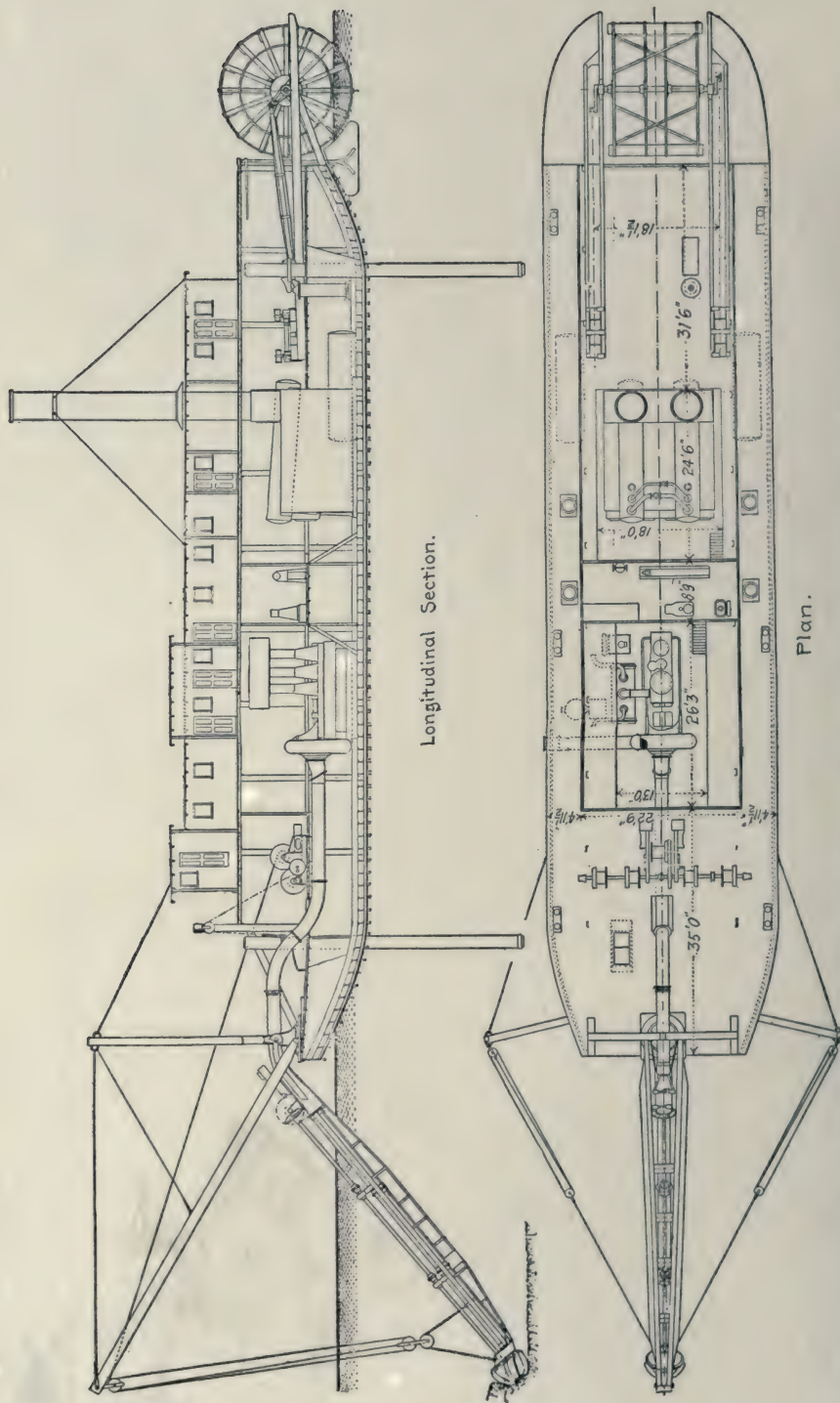

Longitudinal Section.

Plan.

Fig. 37.—Deck Plan and Longitudinal Section of the Dredge "King Edward VII."

spud as a center, and the material is principally deposited on shore or at a distance through the floating discharge pipe.

Referring to the illustrations, Fig. 37 is a deck plan and longitudinal section of the dredge by which the general arrangement of the machinery, crew's quarters, etc., may be seen. Fig. 38 shows cross-section at the pump. Fig. 39 shows the dredge with cutter raised.

The hull of the dredge is 32 ft. wide, 125 ft. long and 7 ft. 6 in. deep. It is built square-ended at bow and stern, with corners well rounded and a rake on the under body fore and aft in order to make

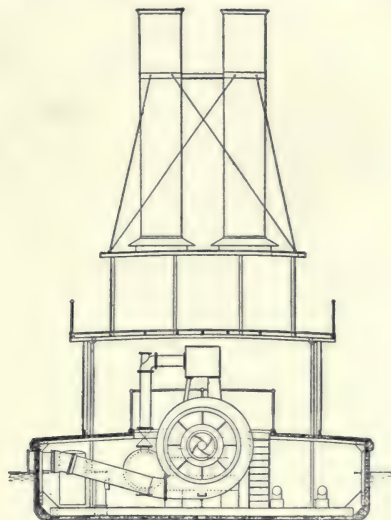

FIG. 38.—Cross-section of the Dredge "King Edward VII."

it fairly easy to propel. By referring to the cross-section it will be seen that the bilges are rounded and that the frame of the vessel is built of steel, while the plank and sheathing are of wood. By this construction great strength is obtained, the steel frames being practically indestructible, while the planking can be renewed at any time when necessary from injury or decay. This form of construction was also especially suitable for erection on the Pacific coast, as the entire frame of the hull could be fitted and erected at the works where built, leaving only the planking to be purchased and put on at place of erection. The hull is stiffened by two additional steel trusses extending the entire length. These trusses are 15 ft.

deep and serve to strengthen and carry the weight of the upper deckhouses. They also sustain the weight and thrust of the front A frame and furnish the necessary support for the wheel beams at the aft end. The hull is further stiffened by four transverse watertight steel bulkheads.

The engines are of the triple-expansion marine type of 500 H.P. The engines and pump as they appear in the engine room are illustrated in Fig. 37. There are no special features about this engine



FIG. 39.—Dredge "King Edward VII."

which call for detailed description. It is simply a first-class marine engine without the link motion. The work of driving a centrifugal pump is somewhat analogous to that of driving a screw propeller, and therefore the type of marine engine is well adapted to the purpose. There are, of course, many little practical details concerning the manner of attachment of the pump and providing for the special wear and thrust that occur in the pump that are different from marine practice.

The dredging pump itself is of the centrifugal type, of a pattern

which has been arrived at through the correction of defects of earlier designs. The pump has a cast-iron shell with cast-steel runner and blades. The suction and discharge pipes are both 20 in. diameter. The blades of the pump runner are faced with renewable steel blades at points of greatest wear and the pump is so designed that it can be readily taken apart and the pump runner removed without taking down the pump shell or discharge-pipe connections. The internal passageways of the pump are of large area, so as to pass freely any stones or solid bodies that may enter through the openings of the suction head without injury or liability to choke it. It will readily be seen that if the passages of the pump were of smaller size than the openings through the cutter head that stones or other obstructions might lodge in the pump, but by the foregoing precaution this liability is obviated.

By referring to the plan it will be seen that the entire suction pipe projects in front of the dredge and swings thereupon, its lateral movement being accomplished by means of a block and tackle on each side, the hauling parts of which are carried to the drums of the auxiliary engines. The suction pipe has a universal movement on the hull so that it can raise and lower as well as swing. This movement is provided for by a section of rubber suction hose where it passes over the deck, the suction pipe being attached by hinges to a revolving base plate on the bow of the dredge.

The material is excavated by means of a rotary cutter head, which is formed of a cast-steel hollow shell and removable cast-steel blades. These blades are arranged on a spiral and so as to give the maximum effect with the least liability of choking. The action of the cutter is such that the blades slice off or excavate the material and feed it into the interior of the shell through the openings, whence it is removed by the pump suction. The cutter head with its shaft, gearing and all connections are of ample strength to stall the engines which drive them. Thus, in case of an immovable resistance being encountered, nothing worse can happen than the stoppage of the engines, and by slacking off the feed of the cutter a little, they are enabled to proceed and try again. It is worthy of note that since this dredge has been in commission she has worked in all kinds of material, including roots, stumps, hardpan and stones, and that no breakage or injury has occurred to the cutter head or its driving gear.

It will be observed that the suction pipe when swinging on the

hull will make a cut about equal to the width of the hull, while the latter is anchored by its two spuds. When it is desired to make a wide cut the suction pipe is secured in its mid-position and the swinging lines are carried out on each side to a shore anchorage, and the entire dredge swings on its stern spud, thus making a cut from 150 to 175 ft. wide at one time. The spuds are oscillating so as to permit the dredge to move up without drifting out of position, and when the move is made, they are lifted and dropped again in vertical position and the work proceeds. The moving up is accomplished by giving a turn or two to the stern wheel by the propelling engines.

The auxiliary engines are on the forward deck. These are for the purpose of working the swinging lines and also hoisting the forward spud. The operator of the dredge controls all the movements of feeding and moving up through the medium of these engines and by bell signals to the engineer. The entire dredge is therefore under the control of one man.

The boilers, as shown on the plan, are of the Heine water-tube type. This type of boiler is not, strictly speaking, a marine boiler, although it has answered very well for this class of work. They are of the usual land type, cased in steel, lined with firebrick. The boilers are designed for a working pressure of 200 lbs. per sq.in., and have an excess of capacity to provide steam for all machinery, and in case of necessity the dredge can work at fair capacity, with only one boiler in commission, while the other is under repairs.

In the engine room the usual auxiliaries are found, such as surface condenser, air pump, centrifugal circulating pump and independent feed and fire pumps. These are all of ample size and conveniently arranged for ease of access and repairs.

The propelling engines are of the stern-wheel type, so often seen on the western rivers. They are of the direct-acting long-stroke horizontal type and have cylinders 16 in. diameter by 6 ft. stroke. They are mounted on a steel frame and have answered the purpose very well.

It will be seen that the whole of the main deck is occupied with machinery and the whole of the upper deck is given up to quarters for the officers and crew.

The performance of the dredge has been quite satisfactory, although no very large or continuous outputs have been made, owing to the fact that the work to be done has been principally

small jobs at different points, and in various kinds of material, some of which has been of a very difficult nature. The capacity of 500 cu.yds. per hour has frequently been obtained, and, under favorable conditions, the output, for short periods of time, has approached 1000 cu.yds., but the average, owing to the reasons already stated, has been much less than this.

To convey the dredged material ashore lengths of sheet steel pipe are used laid on the ground and blocked up where necessary. These pipes are simply slipped into one another like stovepipes, and no special arrangements for keeping them tight. The gravel and clay in the interior soon block up any small openings, and absolute tightness is not required. The material distributes itself over a large area of ground. Thus for land reclamation the value of this type of dredge is evident. The manner of working the dredge and disposing of the material must of course be determined by the local conditions, and while the hydraulic type of dredge has its limitations, its sphere of usefulness, as exemplified in the "King Edward," is considerably widened.

CHAPTER XVI

UNIVERSAL DREDGES

THE hydraulic dredge was originally designed to work exclusively through very loose soils. It was after some years that, in order to extend the field of its usefulness, devices were applied to disintegrate the compact soils so as to be taken up by the pump. The hydraulic dredge is a very efficient machine and superior to any other in working through very loose soils, but in hard and compact soils even with powerful cutters these dredges cannot be favorably compared with other machines. In the extensive works of harbor improvement, which, as a rule, extend over a large area, soils of different consistency are encountered. Even if the cutter succeeded in disintegrating the soils, the débris composed of sharp edged broken stones would soon disarrange the pump. Hence in order to obtain the most favorable results under all conditions, it would be necessary to have at hand two different kinds of dredges, one for the loose soils and another for working through hard and compact materials. In such a case only one machine at a time could work, while the second would remain idle. This would involve a very large expenditure, both in the original cost of the larger plant required for the work, and in its running expenses. To avoid this the two different classes of dredging machinery have been mounted on the same hull, resulting in a new machine, called the universal dredge, being a ladder and a hydraulic dredge combined. Universal dredges are very powerful machines, built similar to regular steamers, able to navigate in high seas. They are constructed of two different types, the universal dredge proper and the universal dredge of the hopper type. The former is the one which has on board the two sets of dredging machinery, besides all the machines and conveniences for ocean navigation. The latter is the one that, besides the two sets of dredging machinery and conveniences, has on board a hopper of larger capacity, in which is deposited the débris to be carried away by the same steamer and dumped in deep waters.

In the simple universal dredge the débris can be disposed of in a different manner. For instance when the excavation is made by the buckets the materials, after reaching the upper tumbler, fall into a chute and are dumped into scows located alongside of the steamer. When the materials are removed by the pump, they are forced to a certain height, from where they may be emptied into scows. Or they may be conveyed to shores either through a long high tube suspended from the sides of the vessel as in the high-tower ladder

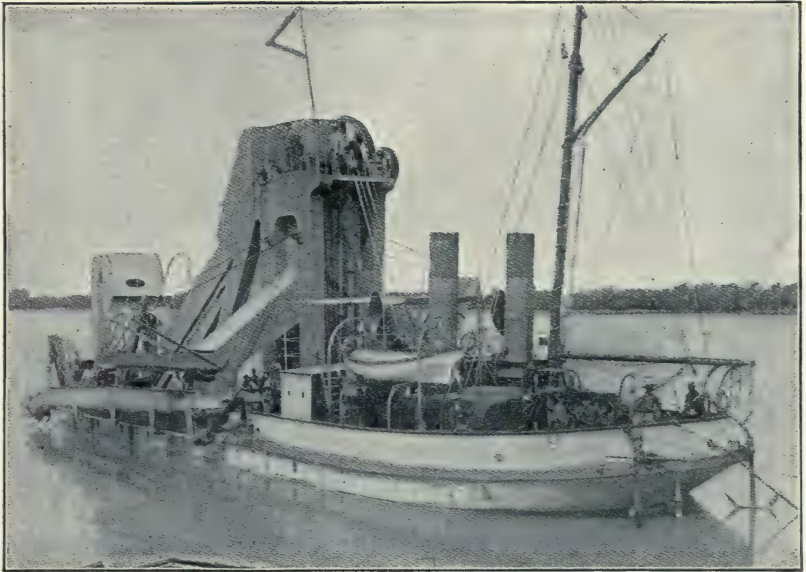

FIG. 40.—Dredge "St. Petersburg."

dredges; or may be conveyed by a long line of floating pipes in the same manner as with the ordinary hydraulic dredge.

The following are descriptions of these two types of the universal dredge. The dredge "St. Petersburg," built by the Henry Satre Fils Ainé et Cie. for the Russian Government, is a universal dredge proper, while the "Montevideo I," built by Messrs A. F. Smulders of Rotterdam for the government of Uruguay, is an example of the universal hopper dredge.

The sea-going dredge "St. Petersburg" (see Fig. 40), is provided with a ladder with a bucket chain located amidship and a centrifugal

pump for the hydraulic dredging. These two different systems of dredging are entirely independent of one another. The ladder dredge is used in the excavation of soils of great resistance, while the hydraulic dredge is used for sands or other finely divided soils. The independence of the two sets of machinery is such that without dismounting any part, a change can be made instantly from one to the other and vice versa.

The dimensions of the dredge are as follows:

Length.....	131.20 ft.
Width.....	31.5 "
Depth.....	10.5 "

The hull is built entirely of steel according to the specifications of Bureau Veritas. The hull is open in front to allow the dredge to cut its own way with the ladder clear out of water. It is divided into six compartments by means of watertight bulkheads. The first and second compartments are located forward and are used for chains and storage. The third at the starboard contains the quarters for the crew, the tower and a store; the fourth at the port side contains the messroom for the officers, and their sleeping quarters, while on deck a large room provided with all the possible conveniences is reserved for the engineers. In the fifth compartment there are located all the boilers and engines and the centrifugal pump for the hydraulic dredging.

The engine is a compound surface-condensing and reversible of the Glück system; it is provided with a friction clutch to regulate the speed of the bucket chain according to the resistance of the soils encountered in dredging.

When hard rocks or other obstacles are encountered, the breaking of any part of the dredging machinery is avoided by means of a brake acting automatically, thus arresting the travel of the bucket chain.

A starting gear driven by a special motor permits the engines to be turned at slow speed so as to facilitate the mounting or dismounting of the bucket chain. In the same compartment with the engines there is a well-equipped repairing shop.

There are two marine boilers of an improved type. The fire-boxes are both extensible and movable. The heating surface of the two boilers together is 1721.6 sq.ft. The grates are of a special system which permit the use of any fuel under the most favorable

conditions. The boilers are arranged to act either together or separately and their efficiency is such that one boiler can provide enough power for both the dredging and propelling machinery simultaneously.

The pump for the hydraulic dredging is lined with steel throughout. A special arrangement of the suction flowing above the water level insures the floating of the vessel without the necessity of sluices, as was previously required in this type of dredge. The articulated joint of the suction pipe is located above the water level, so that it can be easily inspected and not interfere with navigating the vessel.

The engine acting on the cutter at the end of the suction pipe is located to starboard. The cutter will easily break up strata of hard soils encountered in dredging, and in any case it will regulate the proportion of water and materials so as to avoid any obstruction both in the suction pipe and pump.

The ladder supporting the bucket chain is very solid and permits the excavation of soils at different depths varying from 6.5 ft. to 34.5 ft. The extreme end of the ladder is far in advance of the stern in order to dredge its own way as stated above, and also to dredge against the quay walls.

The journals of the axle of the upper tumbler of the ladder are provided with Belleville shock absorbers in order to eliminate the shocks produced when the buckets meet with some extraordinary obstacle.

The 29 buckets of the ladder are entirely made of cast steel reinforced at their cutting edge by a piece of hard steel easily renewed when worn out. The links of the chain are made of cast-steel pieces and the bolt holes are lined with soft steel so as to be easily renewed when worn out. The axis connecting the links of the chain with the buckets are made of hard steel.

A steam crane of special design located at the stern is used for the raising and lowering of the ladder and the lifting of large blocks or rocks too large to be taken up by the buckets. This crane is operated by a reversible engine located in one of the steamer compartments and moved by a belt connection placed on deck.

All the various operations of the dredge are made by special double-cylinder engines easily handled so as to have on board the smallest possible crew.

Telephones and electric bells afford communication between the

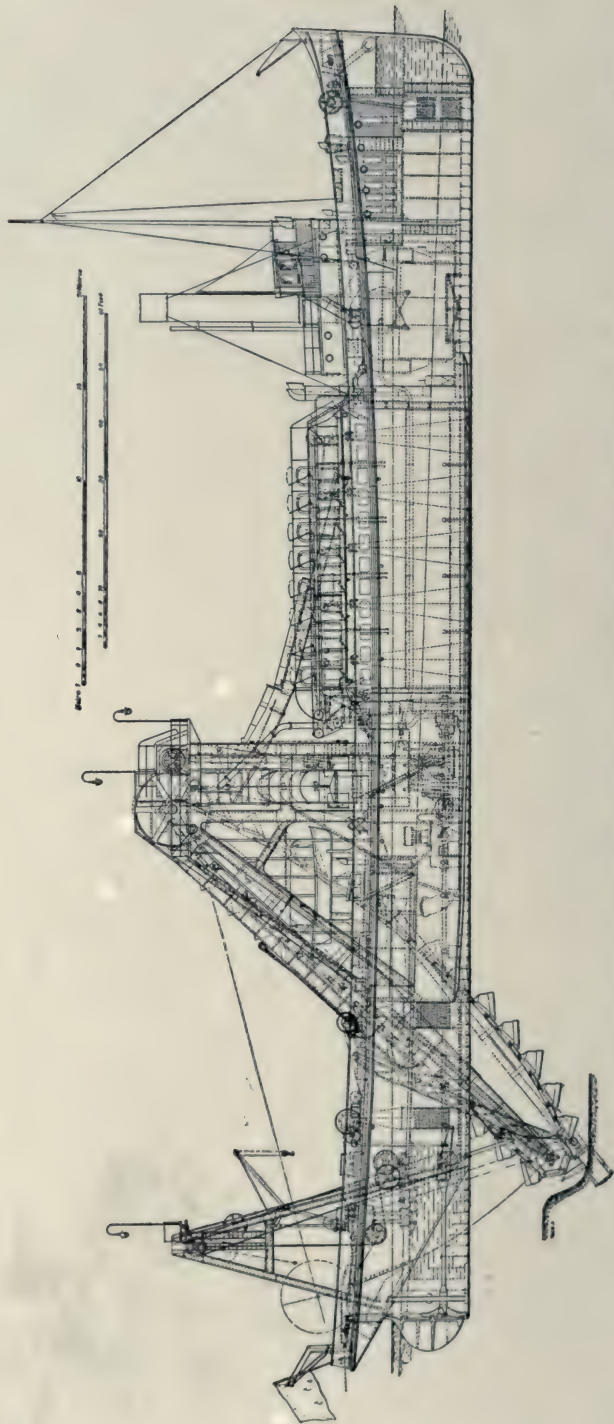

FIG. 41.—Longitudinal Section of the Dredge "Montevideo."

commanding officers on deck and all parts of the steamer, especially with the various engines.

Owing to the severe climate in which this dredge was to work, it was fitted with all the conveniences, and the officers' quarters are heated both by steam and open fire, while the dredge is heated by steam throughout.

On deck in front of the boilers is the bridge, on which is located the pilot house.

The steamer is provided with two masts and sails so as to navigate also under her own sails as it did from Marseilles to Libau.

The dredge "Montevideo," see Fig. 41, built by Messrs. A. F. Smulders of Rotterdam, for the harbor works of Montevideo, Uruguay, and described in Engineering, April 3, 1903, serves to illustrate the hopper type of the universal dredge.

A special feature of this machine consists in the fact that it is arranged to dredge at will through the same well, either with a chain of buckets or by means of a suction pipe. When using buckets the dredge can work to a depth of from 13.12 ft. to 32.81 ft. below the surface of the water, with the ladder in its ordinary position; while by altering the upper bearing of this to a special support the depth reached can be extended to 42.65 ft. below the water line. The minimum efficiency required by the contract was an excavation of 654 cu.yds. per hour when working to a depth of $26\frac{1}{4}$ ft.

The spoil can be delivered from the dredge either into a well of 1046 cu.yds. capacity, or into hopper barges placed alongside the dredge. The distance of the top of the wells of these barges when light is 9.84 ft. above the water level, and 6.56 ft. away from the dredge horizontally. When carrying its own spoil the dredge was required not to draw more than 13.94 ft. and to be capable of steaming out to sea with its own screw for unloading. When arranged for suction dredging the machine is designed to work at depths of from 13.12 ft. up to 32.81, and when working at depths of $26\frac{1}{4}$ ft. it was required to fill its wells of 1046 cu.yds. capacity in 40 minutes. With wells laden its speed on proceeding to sea was required to be not less than 7 knots, and its engines were also required not to consume more than 2.20 lbs. of coal per indicated horsepower per hour. The dredge when finished proceeded to Montevideo under its own steam.

The hull is of Siemens-Martin steel, and is 241 ft. long by 41 ft.

wide by 17 ft. 3 in. depth of hold. The hopper has a capacity of 1250 tons and is 50 ft. long by 33 ft. 10 in. wide at the top and 23 ft. wide below. Fully laden, and carrying 50 tons of coal in the bunkers and 5 tons of water in the boilers, the draft is 13.94 ft. The mean speed attained on runs with and against the current was 8.2 knots. Installed in the hull are two compound engines placed nearly amidship, which drives at will either the bucket chain, the centrifugal pumps for the suction apparatus, or the two propelling screws. The two engines together develop 1000 indicated horsepower. They are supplied with steam by two ordinary return-tube boilers, placed forward and built of steel under the Veritas rules for a working pressure of 113.8 lbs. per sq.in. The two together provide a heating surface of 3444 sq.ft. The steam for the dynamo engine and for the centrifugal circulating pump is also taken from these boilers, which are fed by two Worthington pumps. There are also eight steam winches which are used in maneuvering the craft. The framing carrying the upper pinion for the dredging chain is removable above the deck level. The forward legs are secured to the sides of the well, while the rear legs rest on deck, which is stiffened below by a strong beam running across the hull. The total distance from the bottom of the hull to the top of the pinion framing is 53.31 ft.

The ladder frame is a built beam 88.58 ft. long and allows dredging to be done in depths of 13.12 ft. to 32.81 ft. of water without shifting the upper support of the ladder. The upper pinion is of square section, and was cast in a single piece out of white iron. The lower pinion is hexagonal, and is a steel casting. The buckets, of which there are 32, have a capacity of 28 cu.ft. and have the back sides and lips of cast steel, while the body is of steel plate. The links are alternately steel castings of double T sections and steel plates. They are provided with renewable bushing of manganese steel, which can be readily replaced after wear. The bolts are also of manganese steel, and have square heads. The bucket speed is such as to bring 16 over the top pinion every minute.

The transmission gear fitted to the main engines allows either of them to be used for driving the chain, or each for running a centrifugal suction pump. It is also possible to use one engine for driving both screws, while the other runs one of the centrifugal pumps. In the latter case one of the screws is driven by means of gearing. The centrifugals are driven from the engine, but the dredg-

ing chain is driven through steel spur and bevel-gearing by means of friction clutches, which slip in the case of an excessive load on the chain, and thus prevent breakage. The centrifugal pumps are driven direct through claw couplings on the crank-shafting, and are designed for a maximum speed of 150 revolutions per minute. They are built up of steel plates and angles, renewable plates of steel being fitted inside the casings. The latter are designed so as to admit of the interior of the pump being easily inspected. The impellers have four arms, also fitted with renewable wearing plates. The suction is long enough to allow of dredging to a depth of 32.8 ft. It is so fashioned that with the dredge steaming fully laden it can be carried entirely above the water level. The discharge pipe from the pumps is of rectangular section, and runs along almost the whole length of the hopper. It is provided with sluice openings corresponding to each section of the hopper.

Six cabins are provided: one each for the engineer, the chief dredgeman, the chief mechanical engineer, and two others for the two assistants of each, while the sixth is reserved as messroom. The accommodation for the crew is sufficient for the needs of ten men.

The boat is lighted electrically by means of three 1000-candle-power arc lamps, in addition to incandescent lamps in the cabins and engine rooms and stokehold.

The navigating bridge is placed in front of the funnel, and is fitted with steam steering-gear engine, telegraphs, and the like. A single foremast is fitted as shown in the figure.

The results obtained on the official trials, made on behalf of the Uruguayan Government on the Meuse, during a period of fifteen days, are given below:

	Condition of Content.	Actual Results.
Dredging by bucket, output per hour.....	500 cu.m.	650 cu.m.
Suction dredging, output per hour.....	1200 cu.m.	1800 cu.m.
Speed.....	7 knots	8.2 knots
Fuel consumption, per I.H.P. per hour.....	1 kg.	0.95 kg.

CHAPTER XVII

STIRRING DREDGES

STIRRING dredges can be sometimes employed with advantage for the removal of materials from the bottom of rivers and harbors. When the bottom is composed of very finely divided particles it is evident that by stirring up these deposits while the water has a given velocity, the water will carry in suspension the particles to be deposited again at a great distance from the original point. Then the dredging operation is simply reduced to stirring up the materials at the bottom, while the water acts as a means of transportation, and the erosive dredges used for such a purpose will be simply provided with a device for the agitation of the materials.

For the successful employment of the stirring-up process as a means of excavating the bottom of channels, rivers, harbors, etc., two conditions should be satisfied: First, the material should be reduced to very finely divided particles so as almost to float when agitated, and consequently it is only applicable to the finest sands and muds. Second, the water holding these materials in suspension should have such velocity of flow as to carry them to deep water or to localities where they will not interfere with navigation before depositing them. Hence this method of dredging can only be applied under given conditions. Thus in the harbors and tidal rivers it cannot be used, but during the ebb tide and in the ordinary rivers where the velocity of water is such that will permit the materials to remain in suspension until deep waters will have been reached, thus preventing the formation of other obstructions down stream.

Different devices have been used to agitate the bottom; the most common being the harrow, the revolving drums, the screw propeller and the pump. All those that have been used and have given good results will be described. There are, however, numerous other methods all covered by letters patent. A long list of these devices can be found in the paper on Dredges and Dredging in the Mississippi

River, by Mr. J. A. Ockerson, C. E., Trans. Am. Soc. C. E., Vol. XL. This long list of patents is due, so Mr. Ockerson says, to the fact that the United States Government offered a premium of \$100,000 for the best means of removing the sand-bars along the Mississippi River. No wonder that the attention of so many inventors was turned in this direction.

Harrows and Scrapers. Since the Middle of the 14th century the Venetians have employed the stirring process for the removal of sand-bars which were formed by the accumulated deposits of the tide, and they made use of the ebb tide as a vehicle to transport the materials away from the point of excavation. At that time the stirring was done by scraping the bottom with iron harrows attached to long wooden handles. They were operated by men in small boats. The operation was carried on during the ebb tide only, so that the suspended materials were carried out to sea by the receding water.

The method was used in England years ago. Mr. Cresy, in his Encyclopedia of Civil Engineering, thus describes the Floating Clough, a machine used for scouring out the channel of the river at Great Grimsby and also on the Humber. The scraper used was a frame 12 ft. long, 9 ft. wide and 6 ft. deep of 6 x 4-in. timber, covered with 2-in. plank, through the middle of which was a culvert 2 ft. 6 in. wide, made of planks, with a small lifting door at one end. At the bottom two beams projected in front, serving as feelers to keep the machine in its right position. In front are placed frames of timber shod with iron, cut in a serrated form, which, by means of a lever, can be raised at pleasure. At the sides of the machine are wings, sloped to accommodate themselves to the fall of the banks. The machine is moored in the middle of the stream, with the wings extended by means of ropes, and at half flood the water is admitted into the scraper by removing the plugs, and the machine sinks to the bottom; the plugs are then replaced, and the scraper remains in this position till flood tide. The iron-shod frame, with teeth like a saw, are let down in front, and the whole machine, being forced along by the tide, scrapes up the bottom, and the mud disturbed is carried along by the receding tide for a distance of three miles or more in the space of two hours.

In the United States the method of dredging by stirring up the materials was successfully employed in the improvement of the mouth of the Mississippi River. In the years 1853-1858

and 1860 the channels were cleared by raking or harrowing the bottom, and they remained cleared as long as operations were continued, while as early as the years 1837 and 1839 the use of dipper dredges served by scows proved a failure, since in a one night storm all the materials that had been removed after a great expenditure of time and money were brought back. For this reason Major M. D. McAlester, U. S. A. Corps of Engineers, in the report of the Chief of Engineers for the year 1866, states that the plan of stirring up the sediment forming the bars within the limits where greater depth of channels is required is most efficacious and economical.

In the harrowing process, successfully applied in the 50's the machine consisted essentially of a wooden frame of rectangular shape, one end of which was attached horizontally to the stern of a sidewheel steamer and turned about a horizontal axis, while the other contained the iron teeth for harrowing and was held in contact with the bottom of the channel, and raised entirely out of order, as necessity called for, by means of tackling rigged to shears resting on the deck of the vessel. In using this machine many interruptions of work occurred, owing to the necessity of repairing the parts of the rake damaged in consequence of impact with wrecks.

On the same principle more powerful machines were constructed later on and used in different sections of the Mississippi River. Thus, for instance, in the year 1867 an appropriation of \$96,000 was made for the construction of two dredges, the "Montana" and the "Caffrey" to be used on the upper Mississippi River between St. Paul and the mouth of the Illinois River. The dredges were sidewheel steamers. The "Montana" was 210 ft. long, 35 ft. beam and 5½ depth of hold, and was equipped with two engines having 20-in. cylinders and 7-ft. stroke; while the "Caffrey" was 150 ft. long, 30 ft. wide, with 4½-ft. hold, with a draft of 32 in. She had 15-in. cylinders with 5-ft. stroke. These dredges were equipped with scrapers designed by Col. Long. These scrapers consisted of a frame attached to the bow of the boat and carrying a heavy crossbar to which were attached six steel buckets or cutters. This frame could be raised or lowered at will. In operating, the boat went to the upper side of a reef, the scraper was lowered and the boat was then backed slowly downstream, scraping the sand with it down to deep water below the reef. This operation was repeated until the desired depth was obtained.

This scraping was continued for several years at a cost of about

\$20,000 per each steamer, but since the relief was only temporary and had to be repeated from year to year, it finally gave place to the so-called permanent improvement, consisting mainly of channel contraction.

Stirring by Revolving Wheels. The agitation of the bottom by means of revolving wheels has been done in two different ways, viz., by the Bishop conical screws and by propellers.

The Bishop conical screws consist of two conical screws abutting together at their vertices and spreading out at their bases so as to form a flat letter V. These are supported by a heavy upright frame to be attached to the bow of a vessel and arranged to raised or lowered so as to bring the screws in contact with the bar, the point of the V being forward. The screws are revolved on bearings at the two ends of each by guard wheels, run by the engines of the vessel to which the machine is attached, or by an auxiliary engine if desired. They are connected with the motor by endless chains. The screws, revolving in opposite directions, were expected to cut a furrow through the bar, breaking up its surface and washing it up into the river current to be floated away. This device was applied to the steamer "Wiggins" in 1867, but gave unsatisfactory results owing to the fact that the screws, lowered to 16 or 18 ft. into the water and projecting far from the front of the vessel, made the machine clumsy, so it became unmanageable in the muddy water.

The steamer "Wiggins," on which the Bishop screws were tried, was provided with two conical screws 20 ft. long, 5 ft. in diameter at their bases, and placed in such a manner that their points came together in front of the boat's cutwater, and their bases were separated from each other so as to measure about 20 ft. from "out to out." They were mounted so that their axes were horizontal. Their flanges were 12 ft. wide at the base of the cones, diminishing to 6 in. at the points.

Propellers. Propellers of large diameter were also used to stir up the materials from the bottom of channels. In the year 1859 Mr. Charles Hyde, noticing the small progress made by the scrapers in removing sand-bars, decided to adopt more powerful means of agitating the materials and used the propeller "Enoch Train." A vessel was constructed with two ship's propellers at the stern and with water tanks which could be filled to sink the hull so as to bring the propellers in contact with the bar and by their revolution cut and stir it up, to be swept away by the river current.

In the year 1867 Major McAlester designed the U. S. dredge "Essayon" using the propeller "Enoch Train" as a means of stirring up the material. The dredge boat "Essayon" was a double-ender provided with two strong and powerfully driven-screw propellers, one at each end, driven by separate engines. She was provided with watertight compartments so that when empty the vessel drew 16 ft. and when full of water 24 ft. The total depth of the vessel from the spar deck to the bottom of the keel was 26 ft. Her spar deck was nearly flat and clear of obstruction from both ends to near amidship, to facilitate the addition at any time of any other device which would be found necessary. It was provided with a single pilot house located amidship. The screw propellers were 16 ft. in diameter, describing circles equal to the minimum draft of the vessel. The propellers were provided with four blades and their ends were shaped so as to readily cut away compact mud. The dredge "Essayon" was built by the Atlantic Works, Boston, Mass., at a cost of \$223,000. It was found very efficient. The depth of water on the bar at Pass à l'Outre was increased from 11 ft. 6 in. to 17 ft. 8 in. and kept at such a depth. But long delays to the work were caused by repairing the blades of propellers, which were easily and frequently broken by obstructions encountered. This fact suggested some modifications, which were introduced on a second dredge of the same type, called "McAlester," in which the propellers were more solidly built. A plow was placed in front of the excavating screws and also a large scraper, 18 ft. across and 10 ft. high, to be lowered directly in front of the plow, to make the machine more efficient and prevent the breaking of the blades of the propeller by coming in contact with obstructions.

Stirring by Jets. To stir up sand-bars by forcing a jet of water upon them was suggested by Messrs. Scott and McClintock. They constructed a machine for forcing jets of water at high pressure so as to dislodge the sand and mud. Although this method did not work well at the delta of the Mississippi River, where the material varied from sand and mud to gravel and clay, yet it was successful in other cases where the bars were formed by very fine sands. In the Report of the Chief of Engineers for the year 1882 is given a description of a hydraulic excavator which was used in the improvement of the Mississippi River and employed in grading the banks for receiving a revetment. The excavator consisted simply of a powerful steam pump placed upon a scow and furnished with the necessary boiler

power and hose for throwing powerful jets of water. The boiler was 20 ft. long and 42 in. in diameter with two 14-in. flues and had a nominal 25 H.P. The pump provided two jets thrown from 2-in. nozzles, the water being conducted from the pumps to the desired point through flexible 4½-in. 6-ply hose. By a special arrangement the steam was guided by only one man. Although in this case the excavator was used more properly for land work than for dredging, yet the same device was applied one year later to stir up the material at the bottom so as to easily enter the lower end of a suction tube of a hydraulic dredge.

For many years the harbor of Swansea, whose bottom was composed of fine sand and mud, was kept clean by means of the stirring process. The machine employed was a powerful steam pump mounted on a boat. At the beginning of the ebb tide the pump was put in motion and the boat sailed along determined courses, agitating the bottom, and the fine particles of the materials that were very light floated in the water and were carried away by the receding tide. The machine could work only a few hours a day and by changing continuously the course of the boat, the harbor was scoured in all directions and the bottom kept at a given level. This method has now been abandoned and a powerful double ladder dredge has been substituted, not only for cleaning the harbor, but to deepen its bottom so as to accommodate vessels of larger capacity.

Revolving Drums. Revolving drums or rollers have been used to stir up the material and thus allow it to be carried away by the velocity of water. One of these machines, called the "hedgehog," was used in Lincolnshire and is thus described by Mr. Ed. Cressy in his *Encyclopedia of Civil Engineering*.

The "hedgehog" in use for removing mud in rivers, or the accumulation on the land side of sea-sluites; is cylindrical in its form, like a garden roller. Around the outside are attached eight or more longitudinal ribs, each of which is armed with as many spades or hoes fixed in them firmly by bolts and screws. This cylinder revolves on pivots in gudgeons in the side frame, which is made of oak, and diagonally braced in front of the roller or the revolving cylinder. The iron spades, 9 in. long and 4 in. wide, placed about 7 in. apart at each end of the shaft, are attached to a strong chain, by which it is moved. When used it is attached to the stern of a barge, which in Lincolnshire is usually drawn by horses. Sometimes a barge is moored at some distance from the mouth of the sluice to

be cleansed, and the "hedgehog" is moved backward and forward by blocks and chains. Such a machine, made of oak and well bolted together, is most effective; as the cylinder revolves on its axis, its sixty-four spades are all brought into work, thus stirring up a vast quantity of mud, which the stream through the sluice aids in carrying away. The timber frame is scantling 6 in. by 4 in., cross-stays from one side to the other being placed 3 ft. apart; and between them are diagonal braces, which are made fast to the frame and stays by iron bolts. The stocks on the cylindrical drum or iron wheel are 6 ft. long and made of oak 6 by 4 in., into which pass the iron spades.

CHAPTER XVIII

PNEUMATIC DREDGES

COMPRESSED air has been used for dredging purposes. Although in the form used it proved to be more expensive than any other process, yet there are cases in which it might be found economical. For this reason the writer has collected all the information possible on this subject, having obtained it from the *Scientific American*, *Engineering News* and *Compressed Air Magazine*.

Pneumatic dredging was done at Uleaborg, Finland, with a dredge designed by M. Jandin of Lyons, France. This dredge was used to excavate a canal 20 ft. deep from the city of Uleaborg

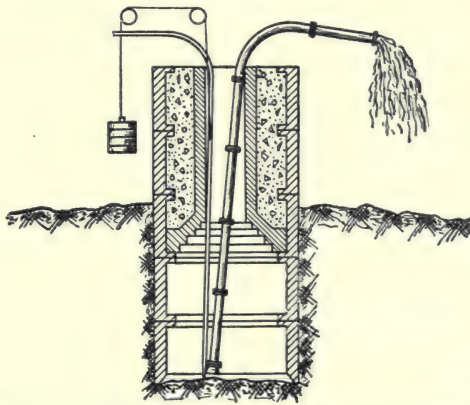

FIG. 42.—Jandin Method for Sinking Tubular Piers.

to the Gulf of Bothnia at the mouth of the River Ulea, where the depth of water had been reduced to about 13 ft. by accumulations of sand.

M. Jandin applied in this dredge an apparatus which he had successfully employed in sinking tubular piers for the Palma del Rio bridge over the Guadalquivir River. The apparatus (see Fig. 42) consisted of a tube 8 in. in diameter and connected at the bottom

with another smaller tube carrying compressed air, which passed into the discharge columns by an annular orifice. The principle upon which the device works is that a mixture of air and water is formed in the discharge column, which is lighter than the water outside, and the difference in pressure is sufficient to create such a velocity that the discharging current will carry with it a certain amount of the material to be excavated.

The apparatus can be used to depths of 131 to 164 ft. below the water surface, in suitable material, without exceeding an air pressure of 2 atmospheres. The only conditions for its successful use are a depth of water of at least 10 ft. and a height of discharge having for its practical limit one-third of the depth. The same system can be successfully used to transport materials horizontally, the friction in the conduit being much decreased by the air mixed with water.

In the dredge designed for the Canal at Uleaborg the excavating apparatus consisted of a hydro-pneumatic dredging pipe, which raised the mixture of water and excavated material, and emptied it into a large cylindrical reservoir, which constituted the forcing apparatus. The dredging pipe, the orifice of which rested constantly upon the bottom, formed the axis of a rigid frame which was guided vertically by the sides of a well at the extremity of the boat. Its upper part was connected with a horizontal pipe which entered the reservoir through a flexible elbow. Near the lower orifice of the dredging pipe there was arranged an annular injector, which introduced compressed air into the pipe. This injection of air produced a suction, while at the same time it formed in the pipe a mixture of air, water and material carried along by the water, a mixture whose density was less than that of the water. It is easily conceived that with a given depth of water it was possible, with the coefficients furnished by experiments, to calculate the volume of air necessary to make the external charge upon the orifice greater than the weight of the column of the mixture ascending above the level of the water to a fixed height.

The principal advantage of this system is that there is no obstruction possible, as the orifice presents a passage that is smaller than the constant section of the pipe, and no parts in motion are in contact with the excavated material. In this way are avoided two of the inconveniences of pumps applied to dredging, and which cause frequent stoppages and necessitate costly repairs.

Jets of compressed air, arranged around the orifice and directed against the earth, disintegrate the latter and increase the proportion of the material carried along by the velocity of the water; a proportion which in ordinary depths of 20 or 25 ft. reaches, as regards sand, 25 per cent of the volume of water.

The suction pipe 10 in. in diameter was actuated by a compressor of the capacity of 211 cu.ft. of free air per minute. The forcing apparatus consisted of a cylindrical reservoir 10 ft. in diameter and 22 ft. long with convex ends having a capacity of 176 cu.ft. This received the mixture of water and material, the air escaped through an opening surmounted by an open dome, upon the side of which there was a wastepipe. When the reservoir was full and the water was making its escape through the wastepipe, a single external lever, operated by the chief dredgeman, closed valves that in turn closed internally the orifice of the dredging pipe, and opened the air port, and at the same time reversed, through three-way cocks, a current of compressed air, which was then forced through distinct pipes into the reservoir and led to injection tubes, properly spaced in the lower part of the reservoir. The effect of the jets of compressed air, formed under the mass of earth and water, was to lift the material while mixing it with water and throwing it, as if by successive shovelfuls, toward the orifice situated at the lowest point of the excavation.

The air traversed the mass of water and material and flowed to the upper part of the reservoir, where was gauged the pressure, corresponding to the distance and height to which the material was forced.

The total time taken to force to a distance of 1000 ft. was six minutes, two of which were consumed in the passage through the conduit. The tubing or pipe was filled by the escape, at the end of the conduit, of a wheat-sheaf jet of water and air projected through an explosion to 48 ft. from the orifice, the conduit remaining empty and being cleaned out by this final action of the air. At the same time the automatic valve that closed the upper orifice of the reservoir was opened by its own weight. The lever that worked the cock was then reversed and the air sent to the dredging pipe and the pipe was again filled.

Thus the dredging and forcing occurred successively at periods of from 5 to 6 minutes, the boat remaining immovable during the forcing period.

The compressor used was provided with double horizontal

cylinders and was driven directly by two compound steam cylinders with variable expansion, with condenser. The advantage of this arrangement was that, since the expansion was effected successively in the two steam cylinders, the stress upon the piston varied within quite narrow limits. This suited the conditions of the work of compression, as the maximum stress was produced in the compressing cylinders during the period of forcing the excavated material.

The carrier or conveyor consisted of two iron plate pipes with Jandin's joints of steel rings and rubber washers, secured with conical pins. Here and there were arranged flexible joints, which were likewise employed for the jointing of the dredge pipe and the connecting of the floating conveyor with the forcing apparatus carried by the boat.

The dredge was self propelling. The boat was maneuvered by means of mooring chains anchored at a great distance and payed in and out by four steam winches located one at each corner of the deck of the pontoon upon which were mounted all the machinery.

Pneumatic dredging is specially adapted to the forcing of the dredged material to a great distance, or to elevating it upon the bank to considerable heights, for the pressure at the beginning of the conduit may easily reach three atmospheres, which would effect an elevation to 95 ft.—a height that exceeds the ordinary conditions. When the material is to be forced but a short distance, as emptying it behind a jetty, the system may be so arranged that the dredging and forcing may be effected continuously and simultaneously. The dredging pipe is then prolonged directly to the floating conveyor, to which it is attached by a flexible metallic elbow.

In hydraulic mining a hydraulic elevator is sometimes used to raise the sluiced material from the bottom of pits and river bottoms. The sluiced material entering the pipe is met by a jet of water under pressure which forces the material to the desired height. The efficiency of the elevator is increased by an auxiliary opening admitting the proper proportion of air. Material is raised in this manner 100 ft. or more. This might be termed a form of dredging.

CHAPTER XIX

DIPPER DREDGES—GENERAL DISCUSSION

THE dipper dredge can be likened to an ordinary steam shovel mounted on a scow or float. This machine is very convenient for dredging in shallow waters and has been extensively used along the shores of the Great Lakes and in the excavation of canals for drainage purposes on the flat and marshy lands along the rivers and seashores of the Atlantic and Gulf coasts. It has done extensive and important work at a comparatively low cost, so that to-day many contractors and engineers believe implicitly in the efficiency of the dipper dredge, and prefer this machine to any other type of dredge.

The hull is built with a flat bottom, so as to allow the machine to float even in very shallow water. The hull is always made of wood, formed with keelsons and floor planking caulked in the usual way. The deck is formed by beams connected to the keelson by means of verticals, supporting a heavy caulked planking. The bow and stern sides of the hull are formed in the same way by beams planked and caulked. In dredges of large capacity, in order to support the heavy boom and its attachment and at the same time to stiffen the structure so as to prevent any damage, the hull is reinforced by steel trusses. Two trusses are placed longitudinally along the starboard and port sides of the float, and these are well braced together by crosspieces connecting the top and bottom chords of the trusses. Another truss, but smaller, is placed at the bow and connected with the two longitudinal ones. This is necessary to support the turntable upon which the boom rests. In Fig. 43 are shown the plan and elevation of the steel trusses used to reinforce the hull of the dredge "Chicago," as given in *Engineering News*, Vol. XLV. The dimensions of the hull depend to a great extent upon the capacity of the machine.

To prevent the dipper dredge from tilting under the great strain of the work, the hull is provided with three and sometimes even

four spuds. These are heavy square beams which are sunk into the ground so as to firmly support the float in the same manner as the legs of a table. Spuds have been used for many years, as evidenced by the machine described by Mr. Hachette, employed at Venice, which is really the prototype of the dipper dredge.

Spuds may be either vertical or inclined; in the latter case they rest on the banks of the canal to be excavated by the dredge, and are called bank spuds. They are used only on dredges of small capacity when employed in the excavation of small and shallow canals. (Fig. 44.) Vertical spuds are very important on dredges

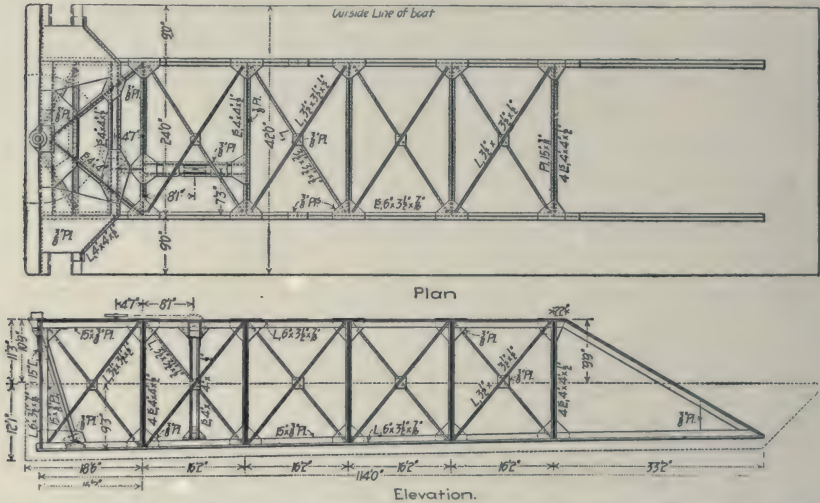

FIG. 43.—Plan and Elevation of Steel Trusses Reinforcing the Hull of the Dredge "Chicago."

of large capacity and then they are operated by special engines. As a rule dredges are provided with three spuds—two of them located at the bow either side of the frame supporting the boom, and these are of larger dimensions than the spuds at the stern. Thus for instance the dredge "Chicago" was provided with three spuds, each of the two forward ones being composed of a single stick of Oregon fir 40×40 in., 55 ft. long. The stern spud was of white oak 24×22 in., 55 ft. long. To facilitate the penetration of the spuds into the ground their lower end is provided with heavy castings. The raising and lowering of the spuds is done by means of steel wire ropes passing over sheaves and controlled by special

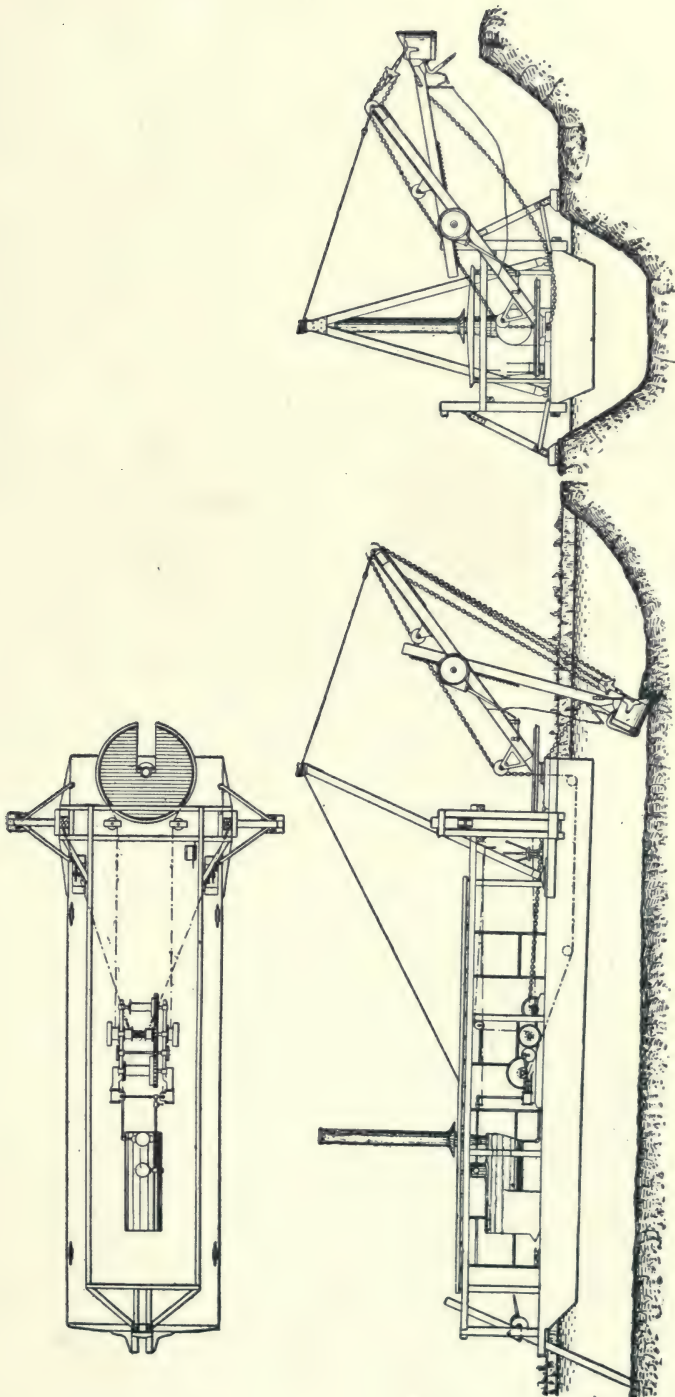

FIG. 44.—Side and End Views and Deck Plan of a Small Dipper Dredge with Bank Spuds.

engines. The rope for lowering the spuds passes over a grooved sheave fixed at the top of the spud, and its free end is fastened to the forward side of the spud casting. The rope for raising the spud is also attached to the forward castings and passes around the sheave in a slot close to the foot of the spud. The other ends of the rope are attached to opposite ends of the drum of the spud engine. The spud at the stern is operated by a rope fastened to the bottom of the spud and passing over a sheave on deck and thence to the drum of another engine.

The dredging apparatus consists of a steam shovel proper of large dimensions and made up as usual of an A frame supporting a swinging boom with its dipper handle and bucket.

The A frame is composed of two slanting beams firmly fixed to the keelson of the hull and resting on top, one against the other, thus forming a truss in the shape of the letter A. This frame is a little inclined toward the front and it is held in position by iron rods or backstays provided with turnbuckles fixed to the stem. In dredges of small capacity the A frame is generally composed of two simple wooden beams, but in dredges of larger capacity the frame is made of two built-up iron beams so as to form a very stiff and solid structure. The top of the A frame is always furnished with a gudgeon pin around which swings the iron rod supporting the top of the boom. According to the capacity of the dredge the A frame is made of different heights, varying from 16 or 20 ft. in the smallest up to 75 ft. in dredges of large capacity.

The boom or jib is a heavy trussed steel beam with a long slot in the middle kept in an inclined position by iron rods, holding its upper end to the top of the A frame, while its lower end rests on a revolving table. The trussed beam forming the boom is usually made with the lower chord straight and the upper one curved or vice versa, but in very large dredges to make the boom more solid and stiff and in better condition to support the weight of the loaded bucket, the boom is built up with curved top and bottom chords. The length of the boom varies with the capacity of the dredge and it is made of different lengths, varying from 20 to 50 ft. It is the swinging of the boom that causes the bucket to revolve in a large radius, thus covering a large field from a single station. The swinging of the boom is done by means of a turntable in whose center is fixed the lower end of the boom. The turntable is built up of steel plates and angles and is supported by steel wheels moving

along a circular track, of varying diameter, reaching to 20 ft. on the larger dredges. The turntable is provided with a horizontal groove around which passes a chain or rope wound around the drum of a reversible engine. By paying the rope in or out the turntable is turned, carrying with it the boom.

The dipper handle is made of wood reinforced at the sides with iron wearing plates. In small dredges the lower side is provided with a cog rack which travels on pinions mounted on the boom. These pinions are connected with a wheel controlled by a brake so that the dipper can be held in any position. In large dredges the dipper handle is held in place by a yoke and sliding plates arranged in such manner that it can be held in any desired position. The dipper handle is inserted in the slot of the boom and it is made of different lengths, depending upon the depth at which the dredge is designed to work.

The dipper or bucket is similar to the one used on steam shovels. The sides are built up of heavy steel plates riveted to angle irons, while the bottom is only hinged to the back, forming a trap door, which is kept closed by a spring latch. The latch is easily opened by simply pulling a chain, but closes automatically as soon as the dipper is lowered again. When the dredge is designed to work in loose soils the front edge of the bucket is reinforced with a steel cutting edge which can be easily renewed when worn out, but in dredging through compact soils the front edge is reinforced by steel projecting teeth. The capacity of the dredge is always given in terms of the capacity of the bucket, thus, for instance, a 6-cu.yd. dipper dredge is a dredge of the dipper type in which the capacity of the bucket is equal to 6 cu.yds. Fig. 45 shows a dipper dredge of 6 cu.yds. for dredging through loose soils, built by the Bucyrus Co. of South Milwaukee, Wis. Buckets are made of different sizes varying between 1 and 12 cu.yds. A bucket of 6 cu.yds. capacity seems to be the most convenient and is preferred by engineers and contractors. The bucket can be provided with a heavy cast-steel bail, or the boom line may be attached directly to chains stretched between the sides of the bucket. The bucket can be fixed to the handle in different ways, which vary with the different manufacturers. The boom line operating the bucket is attached to the bail, passes over a large grooved sheave on top of the boom, and passing over and along the upper side of the boom and over a second large grooved sheave on the turntable, is wound around the

large drum of a reversible hoisting engine. The line can be either of chains or steel wire cables, the latter being preferred, owing to the lighter weight and less friction, which means less wear.

The various engines necessary for the operation of the dipper dredge are the main hoisting engine, the swinging engine, the engine for the spuds, and an engine for the dynamo. The main hoisting engine is usually of the double-cylinder, double-drum, reversible type and is located on the main deck forward. The swinging engine also is located forward and of the double-cylinder, double-drum reversible type. The spuds can be operated by a single or two separate engines, the former is preferred, but in very large dredges

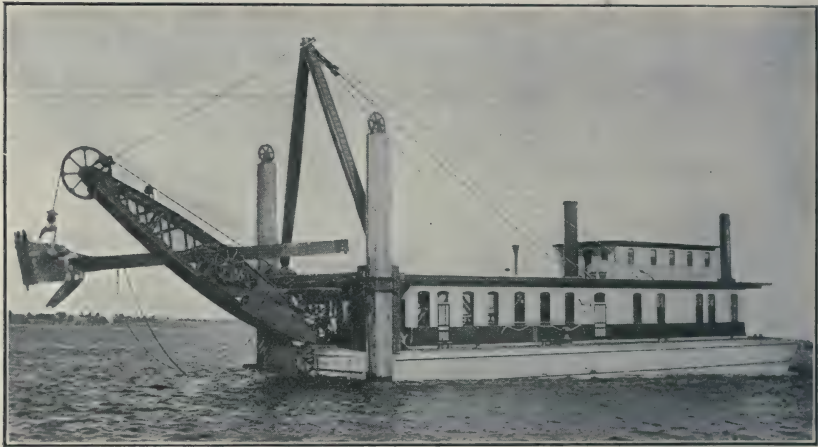

FIG. 45.—Dipper Dredge of 6 cu.yds. Capacity.

the two forward spuds are operated by a double-drum reversible engine, and the aft spuds by a single-drum reversible engine, or all the three or four spuds by a 3- or 4-drum reversible engine. An engine is also required for the dynamos, since the dredge is lighted by electricity and arc lamps are provided on deck so as to dredge even at night. Steam for the various engines is provided by a marine boiler located near the stern. Boiler, water tanks, coal bunkers and some of the engines are placed aft so as to counteract the weight of boom with the heavy bucket when the dredge is in operation, notwithstanding it is firmly fixed to the ground by means of spuds.

All the various dredging operations are controlled by a man who

operates the different engines by means of levers, all located in the captain's room on deck. The dipper dredges of large capacity are usually provided with a deckhouse containing the kitchen, dining-room, sitting-room, staterooms, bathroom and office; but these conveniences vary in class of work done.

The dipper dredge is a stationary machine and consequently is entirely without propelling apparatus or engine. It is able, however, to move from place to place so as to follow the progress of the work without any help from tugboats or from the anchoring chains. When the dredge is to be moved so as to attack a new bed, the spuds are lifted, the dipper handle fully extended is lowered so as to engage the soil as in dredging, the handle is then withdrawn and this effort causes the vessel to move forward. By repeating the same operation the machine slowly advances to the required point. Then the spuds are lowered again, the boat is made firm and the dredging operations are resumed. It takes less than two minutes to lift the spuds, to move to a new place to be dredged and lower the spuds again. The machine can be moved also laterally by rotating around one spud. This is done by the stern spud being held fast to the bottom while the two others are lifted; the vessel will move either to the right or the left by the same operation of the dipper engaging the soil, then the stern spud is lifted while one of the fore spuds is lowered, and the dredge rotating now around this new point will be moved laterally; and repeating the same operation over and over the dredge can be moved the required distance, when all the spuds will be lowered, the machine made fast, and the dredging resumed.

The output of the dipper dredge is an average of one bucket per minute, and for this reason contractors have continuously requested manufacturers to increase the capacity of the bucket. Thus there are to-day dredges with buckets of 15 cu.yds., but the great cost of these mighty machines and their high running expenses so increase the cost of excavation that the work of these dipper dredges cannot be compared with that of other large machines of different type. However, dipper dredges of small capacity working under certain conditions are still considered the most efficient and economical machines.

The output of the dipper dredge assumed at the rate of one bucket per minute gives a fair idea, for rough estimates, of the work to be obtained from the dipper dredge under ordinary circumstances.

There are numerous conditions which tend to greatly alter this estimate, and that must be considered. The presence of stumps and boulders in the ground will retard the work of the dipper dredges. Working through plastic and sticky clay the progress is retarded, owing to the fact that the clay sticks in the bucket for some time after the door is opened before it falls through. A dipper dredge employed to dig canals through marshy land, cutting its own way and depositing the débris on both sides so as to form the ditches, will do a larger amount of work than if used in places in which the débris is placed in scows. The handling of scows by tugs frequently causes delays, similar to those caused by trains in steam-shovel work. Then, too, less work is done when only a few feet of excavation is necessary.

The following examples serve to illustrate the work dipper dredges will do. In one section of the Chicago Drainage Canal five dipper dredges of 2 cu.yds. capacity were employed for dredging through hard clay. The best week's work for four dredges was an average of 1070 cu.yds. per 10-hour shift, while one dredge reached an average of 1530 cu.yds., thus obtaining an average efficiency of nearly one bucket per minute. Capt. D. C. Kingman, U. S. Engineer Corps, reports that at Sodus Bay, N. Y., with the Osgood Dredge "Frontenac" 1½ cu.yds. dipper, from June 26 to 30, 1892, in 45 hours of actual work 4390 cu.yds. of sand and gravel were dug, an average of 97 cu.yds. per hour, or about one bucket per minute. On the Raritan River, N. J., the dredge "Alpha," with a dipper of 1 cu.yd. capacity, armored with teeth so as to work through rock, in the month of September, 1889, working 207 hours, excavated 12,050 cu.yds. of shale rock and gravel; it averaged 60 cu.yds. per hour and consequently at the rate of one bucket per minute.

In Engineering News, February 28, 1901, a report is given of the trial of the dredge "Chicago," with an 8-cu.yd. dipper, working in sand and clay in 25 ft. of water, excavating in 30 minutes 385 cu.yds. of material. This would represent 12 cu.yds. per minute, or one bucket and a half. But it was on a trial performance and not on regular work, being a new machine working only half an hour. However, it is fair to assume from this that large dredges can dig a dipper full per minute.

The output of the dipper dredge depends also upon the locality in which the machine is working. For instance the output of dredges working in wide rivers or bays, where they are not interfered with

by passing boats or scows is certainly greater than in dredges compelled to work in narrow spaces and under crowded conditions. The five dredges employed in the section of the Chicago Drainage Canal, mentioned above, while in the best week's work their output was almost equal to one bucket per minute, yet in the average their efficiency was of one bucket every two minutes, owing to the fact that they were too crowded and consequently often they interfered with one another, and they were served by scows and tugboats. When the dredging work is depending upon other operations it would be impossible to expect the greatest efficiency from the dredge. Thus while the dredge "Alpha," on the Raritan River, could remove shale rock and gravel at the rate of one bucket per minute, yet when the rock was so hard that it was necessary to recourse to blasting, the same dredge on the same locality worked at the rate of one bucket every nine minutes.

The dipper dredge of small capacity is handled by a crew of 6 men, while this number increases with the capacity of the machine, and a dredge of 8 cu.yds. is served by 16 men. The daily running expenses of working the machine are wages, coal, water and oil and waste. Dividing by the number of cu.yds. dredged the cost per one cu.yd. is given. Other costs to be considered are the interest of the capital invested, the wear and tear, and sinking fund, but these will be discussed in a special chapter. These are so important that while in the Massena Canal a dredge worked at the average cost of 4 cents per cu.yd. for labor and coal, the cost for interest and depreciation was 7 cents per cu.yd., thus making a total cost of 11 cents per cu.yd. The other items were almost double the cost of labor and coal.

The dipper dredge is the typical American dredge, and has rendered magnificent services on the Great Lakes. But even to-day, notwithstanding there are so many powerful dredges at our disposal, the old-time dipper dredge of small capacity can be still considered without a rival on small contracts for the improvement of narrow rivers and in digging canals for draining purposes when the débris is deposited on both sides to form the levee. The dipper dredges of small capacity are handled by a few men, are not easily broken, and the repairs are almost insignificant, while in dredges of larger capacity the expenses are heavy when the machine is compelled to lay idle for repairs. Mr. Robinson says that a wooden dredge ten years old, costing say \$30,000, will excavate 1500 to 2000 cu.yds.

in 10 hours with a crew of 6 men and 3 tons of coal. With such a machine, he adds, the marvel is not that American contractors do not use the big and costly European ladder dredges, but that these useful American machines do not find a wider recognition in Europe and abroad.

CHAPTER XX

DIPPER DREDGES

THE following description of the dipper dredge "Independent" condensed from an article in the Engineering Record, June 1, 1907, serves to illustrate one of these dredges of medium size with a bucket of $4\frac{1}{2}$ cu.yds. capacity.

The dredge "Independent," Fig. 46, owned by the Bush Terminal

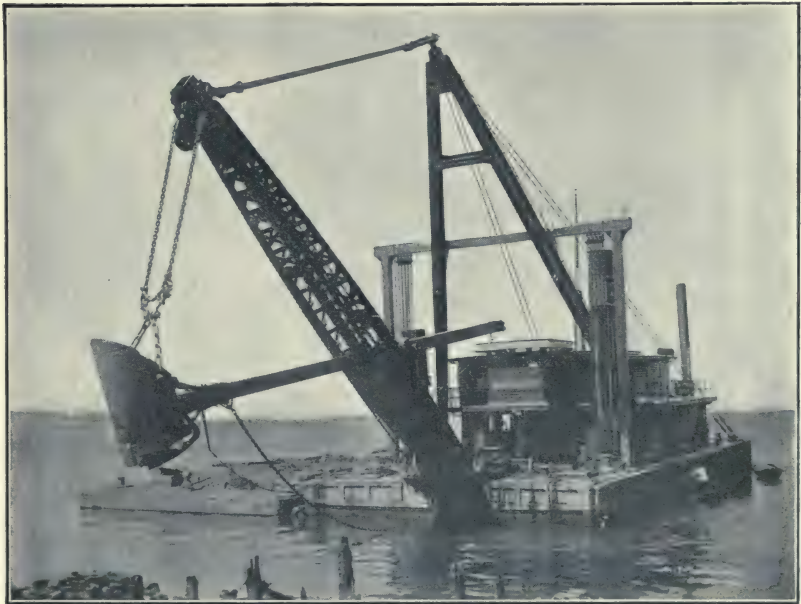

FIG. 46.—The Dipper Dredge "Independent."

Co. of New York, and used in the extension of its docks in South Brooklyn, was built especially for slip work. The hull is 90×38 ft. 2 in., by 12 ft. deep, and unusually heavy. The house is 52×28 ft., containing an engine-room, crew's dining-room, officers' dining-room,

kitchen, washroom and toilet. On the upper deck forward is the operating-room and three cabins for the captain, engineer, and steward. On the upper deck, aft, is a 16×16 ft. bunkhouse for eight men. All the rooms are heated by steam.

The main hoisting engine is of the double-cylinder, double-drum type, placed on the main deck forward. The bedplate is extended in front and carries the inner bearings of the large spur wheels. These wheels are thus made an integral part of the engine and the maintenance of a proper relation between the pitch lines of the spur wheels and the pinions on the main crankshaft is assured. The engine cylinders are 16×18 in. The drums are all actuated by cork-inserted frictions. These frictions are the standard Lidgerwood type, made of hard wood turned to a truncated cross-section and working against a female surface of turned cast iron. Three-quarter inch holes on 2-in. centers were bored in the faces of the wood and corks pressed into them. The holes are staggered so that the corks cover the whole metal surface of the female section as the friction revolves. It is stated that the cork surface about doubles the holding power of the friction and maintains the grip even if grease gets on the surfaces. It is believed that this is the first time cork inserts were used in dredge work.

In the hold is the backing drum, operated by a wheel which meshes into one of the large spur wheels of the main drums. The friction of these three drums is set up by steam nips built with wrought-iron toggle levers and actuated by an Osgood patent steam grip cylinder. The form of this grip is novel. The thrust on the main drums and backing drum is transmitted from the thrust collar to the drum through a special roller bearing made by the Philadelphia Roller Bearing Co. These were adopted to reduce the frictional losses incident to the ordinary arrangement and also avoid the cutting of a keyway through the main shaft. They have proven very satisfactory.

A double-cylinder, 10×12-in. engine is placed in the hold forward and the fore and aft spuds on both port and starboard sides are operated by it, through friction drums. The spur-wheel shaft extends clear across the hold. Near each end it has a pinion which engages two spur wheels, one on each side of the shaft, each of which is connected with a friction drum. These four drums carry chains leading to the four spuds. At the extreme ends of the main shaft are bevel gears through which power is transmitted to two forward

gypsy winches on the main deck. The two stern gypsy winches are operated by a separate $6\frac{1}{2} \times 9$ -in. double-cylinder engine, the power being transmitted through bevel gears as for the forward winches. All the speed drums and their gearings are interchangeable. This includes four drums, their shafts, frictions and other details, the bevel gear wheels and pinions operating the capstans and the capstans themselves. This reduces to a minimum the possibility of delays and cost in making repairs in case of breakdowns, making it possible to be ready for repairs by carrying in stock only one spare piece of each of the parts subject to the greatest risk of breakage. For instance, the level pinions are intentionally selected as the breaking pieces for the capstan gear. There are four of these, yet only one carried in stock allows quick repairs to be made.

The boiler is of the Scotch marine type, 11 ft. in diameter, 12 ft. long and has two 42-in. corrugated furnaces. There are three 4000-gal. steel water tanks in the hold, one on each side and one near the stern. The last is always kept full as a reserve supply and for ballast. There are two double-cylinder Blake steam pumps, one for the boiler feed and the other to pump from the bilge, from a water boat, or from the tanks.

The boom is built of angles, cover plates and lattice bars in the usual manner, and is 53 ft. 2 in. long over all. The head sheaves are attached by a specially designed compact universal joint which gives the wheel freedom of motion in every direction and prevents the breakage of the flanges, which sometimes occurs when a less flexible connection is used. The leads from the tip of the boom to the top of the A frame are attached to the latter by a ball-and-socket joint. This joint is in effect as if the two leads met at one point. Torsional strains in the boom are thus avoided when the boom swings to one side or the weight on the lifting chains is unequal. The four guy cables are $1\frac{3}{4}$ -in. plow steel. The dipper is of the usual type and the 58 ft. handle is made of a 16×16 in. Oregon fir stick, and four $6 \times 6 \times \frac{1}{2}$ -in. angles. The handle is built under the Howard patent. The four angles of the timber are reinforced by $6 \times 6 \times \frac{1}{2}$ -in. angle irons riveted through and through.

The turntable is carried by eight conical wheels attached to the movable or upper plate and rolling on a fixed circular track. The horizontal thrust is taken by twelve vertical cylindrical rollers, equally spaced about the circumference of the moving plate and attached to it. These rollers bear against the outside of the same

rail that carries the weight. This turntable is operated with much less power than those of the usual type where the friction is sliding. The wheels can be removed without unshipping the turntable.

The operating room is arranged so that the captain can control all the movements of the dredge without moving from his position. He can also control the forward gypsies, but those aft, operated by a separate engine, are manipulated by the crew.

The dredge is equipped with an electric lighting plant, current for which is generated by a $7\frac{1}{2}$ -K.W. General Electric generator direct connected to a small vertical engine. The wiring is carried in



FIG. 47.—Dipper Dredge "Majestic."

loricated conduit as in government naval works. A special system of piping with hose connections is provided for fire protection, the bilge and tank pump being arranged so that it can pump salt water for this purpose.

The "Independent" was designed by Mr. W. H. Arnold, chief engineer of the Bush Terminal Co., the engineers of the Lidgerwood Mfg. Co. co-operating in the detail designing of some features.

This description of the dredge "Majestic," Fig. 47, slightly condensed from a paper published in the Engineering News, February 7, 1907, will serve to illustrate a dipper dredge of large capacity:

The dredge "Majestic" built for use on the improvement of the West Neebish channel in the St. Mary's River, Michigan, has a num-

ber of points of special interest, but its two prominent features are the following: First, it is powerful enough to dredge solid beds of soft limestone rock without blasting, and second, loss of time and money due to the renewal of worn and broken main cables is greatly reduced by the use of a drum which enables 500 or 1000 ft. of cable to be held in reserve instead of using and renewing cables of the regular working length.

The hull is of steel, 116×40 ft. and 13 ft. deep, with two steel trusses 24 ft. deep extending the entire length. The trusses are built of 12-in. channels and I-beams. The boom is of steel construction, 60 ft. long, stepped into a steel casting at the bow and supported by four cables 2½ in. diameter leading from the top of a 40-ft. A frame stepped on top of the anchor slides. Two of those cables take the strain and the other two act as safety cables. The boom is swung by a pair of 2-in. cables on a 24-ft. turntable or swinging circle with arms extending on each side of the boom. These cables are wound on a 40-in. drum, compound geared to a pair of separate engines, with cylinders 10×14 in. These engines are set on the hurricane deck and this arrangement gives the cables a straight head from the drum to the swing circle. The dipper handle is 54 ft. long from back of dipper, and weighs 15 tons; with a 5-ft. dipper it will excavate to a depth giving 30 ft. of water. The sheaves for the 2½-dipper cable are 8 ft. in diameter and are of built-up construction; the hub, 3 ft. long, is of cast iron, bushed with a bronze, which runs loose on a 9-in. shaft. The spoke section is a steel casting, keyed to the cast-iron hub; the rim is also a steel casting and bolted to the spokes.

The dipper is handled by a horizontal engine of 250 H.P. capable of exerting, through the gearing, a pull of 200 tons upon the dipper cable. The engine has two cylinders, 16×20 in., and, as in many large dredges, cables are used instead of chains. The engine drives the differential cable drum, 4 ft. and 6 ft. diameter, through compound gearing, requiring 19 revolutions of the engine to effect one revolution of the drum.

The cable drum is of special design, invented and patented by Mr. W. S. Edward, having as its principal feature an extension for about 800 ft. of cable in addition to the 200 ft. working length, so that a single cable 1000 ft. long is carried; with the ordinary arrangement the dredge would have a hoisting cable about 180 ft. long, and when this was broken the entire cable would have to be

renewed, as these cables usually break at about 80 ft. from the outer end and the remainder is then too short for further use. With the Edward storage drum, a cable 1000 ft. long is used, and when this breaks only about 80 or 90 ft. are lost, the working length being restored by paying out sufficient cable from the storage part of the drum.

The drum and gears are all open-hearth steel castings. All friction belts are operated by compressed-air cylinders, the air at 170 lbs. pressure being furnished by two Westinghouse air pumps arranged tandem.

The bow spuds are of great size, 43 in. square and 52 ft. long. Each is composed of four 22-in. sticks dressed on all sides to $21\frac{1}{2}$ in.; these are fitted into a cast-steel shoe at the bottom and bolted together for 8 ft. from the bottom with 24 bolts $1\frac{1}{4}$ in. in diameter. There are no bolts above these, being held together by an iron band $\frac{3}{8} \times 10$ in., so that the individual sticks have a certain amount of spring or movement. In the top of the shoes is a $9\frac{1}{4}$ -in. hole for a 9-in. shaft, 10 ft. long, which is secured to the spud foot by six 2-in. and $2\frac{1}{2}$ -in. staples with jam nuts on the ends. The spud foot is of timbers 16 in. square, bolted together with eight 2-in. bolts 10 ft. long, the size of the foot being 10×12 ft. The purpose of this is to prevent the spuds from sinking into the bottom when the dredge is lifted up on the spuds, when working in soft material. The dredge can be lifted about 2 ft. above its floating position and this is accomplished by means of a 2-in. cable running over the top of each spud on a sheave and fastened to the spud slide. The great weight will then force the spuds from 2 to 6 ft. into the bottom, but the broad feet then keep the dredge steady while in operation. The spud and foot are also raised by means of a 2-in. cable running over a sheave which is fastened to the cast-steel shoe and is operated by a cable and a hoisting drum driven from the main engine through a friction band and drum. The stern spud is a single 28-in. timber, 55 ft. long, operated by rack and pinion. The spud slides in a heavy fixed shoe which carries the pinion on the front face and two bearing rollers at the rear face of the spud. The pinion is compound geared, and driven by a chain of forged steel links and roller pins from a separate engine placed below the deck, the chain passing through this deck to the countershaft of the pinion gear.

This dredge was built to excavate the approaches to the rock cut of the new West Neebish Channel. The material in the approaches

and the rock cut consist mostly of boulders and hardpan, underlaid with limestone, shale and bed rock. The bed rock varies in depth from 6 in. to 14 ft., the layers being in some places 4 ft. thick. A 25-ft. depth of water is required, and it has been found practicable to secure the required depth with this dredge, using a 6-yd. dipper which weighs (without teeth) over 11 tons; there are four teeth on the dipper, weighing 800 lbs. each. It would be difficult to state the working capacity of the dredge in rock, as the latter is overlaid with several feet of boulders and earth, all being dug at one operation, but the capacity is estimated at from 40 to 50 cu.yds. per hour in the rock alone. The capacity in soft material is about 400 to 500 cu.yds. per hour, using an 8-yd. dipper. The cost of running this machine is estimated at \$30 per hour.

The dredge "Majestic" was built from plans of its owners, and has proved very satisfactory in operation. The hull and boiler were built by the Manitowoc Dry Dock Co. of Manitowoc, Wis. The boom A frame, swinging circle, circle sheaves and dipper handle were built by the Bucyrus Co. of South Milwaukee, Wis. The three sets of engines, with drums and gearing, were built by the Jackson & Church Co. of Saginaw, Mich., which company controls the patents for the Edward cable-storage drum above described.

CHAPTER XXI

GRAB DREDGES

ANOTHER intermittent dredge is one equipped with grab buckets. This machine is considered one for great depths, as it is able to excavate at places out of reach of any other machine. The ordinary grab dredge consists of a steel bucket in the shape of a grab, capable of picking up large boulders and soft materials and usually worked by a steam crane, which lets the open grab down to the ground to be excavated and then closes it by a chain, which forces the tines into the ground. The grab is then raised by the crane and the contents are deposited on the sides of the excavation or into barges to be carried to the dumping place.

The grab bucket dredge is a very convenient machine and can be adapted to a large variety of work. In spite of its simplicity it is a useful machine. Any contractor can easily build one of them. By mounting on a float or scow any locomotive crane or derrick with its necessary engines, and by attaching a grab bucket to the hoisting rope or chain, a dredge is obtained. A machine of this class does satisfactory work on the improvement of small harbors and rivers and is extensively used throughout the English Colonies. Besides the common use of dredging the bottom of canals, rivers and harbors for navigation purposes, the grab bucket dredge can be used for digging gold, oysters, pearls, corals and sponges from great depths. In a word its many uses make it a very convenient machine.

The first grab dredge built was perhaps the one designed by Fr. Domenico Ferra and used at Savona in 1773; but the machine as now used was first constructed and extensively used in America, and then introduced into England and her Colonies. There is a difference between the grab dredges built in America and those constructed in England in the mounting and handling of the bucket as well as in the capacity.

The American grab dredge is constructed as follows: The machine consists of a strongly built A frame mounted on a boat and

supporting an inclined swinging boom. The boom rests on a turntable and its upper end is able to revolve around the gauging pin of the A frame, being kept in an inclined position by means of iron rods furnished with turnbuckles. One or two sheaves located at the top of the boom guide the chains controlling the bucket. The bucket, made of steel, is divided into two or more sections provided with lever arms and chains so arranged that the bucket can be closed and open at will. The chains are wound around the drums of hoisting engines placed on deck of the boat, and as the bucket is operated by two chains there are two drums on the hoisting engine. Steam power is supplied to the engines by boilers which are located at the stern of the boat. The boat is built of rectangular form in the shape of a float, with a structure above deck to house the boiler and machines and in some cases even to provide accommodation for the crew. While the machine is in operation the boat is fastened to the bottom by three or four spuds which are constructed and operated as with the dipper dredge. As the efficiency of the machine is considered one bucket per minute, the manufacturers have increased greatly the capacity of buckets and to-day we have grab dredges with buckets of 8, 10 and 12 cu.yds. capacity.

The English grab dredge consists of an ordinary locomotive crane mounted on a boat. The locomotive crane is composed of a large horizontal cog-wheel, whose axis is fitted into a socket of an iron frame, with wooden platform, upon which are placed the boiler and the engine. In front of the iron frame there is a jib or boom braced by means of iron rods, connected to vertical iron stands, and tied to the rear of the frame of the platform by rods provided with turnbuckles. The boom or jib is made of various designs and of different materials, but usually it is made of iron except when very long, when it is made of trussed steel. The bucket is attached to the hoisting chain, which after passing over a sheave at the top of the boom is wound around the drum of the hoisting engine. The engine is so arranged that by putting into gear another small cogwheel whose cogs engage those of the large one supporting the platform, the platform and boom and consequently the bucket turn a complete circle.

The English grab dredging machine is mounted on many kinds of boats, depending upon the locality of the work. In dredging along the quay walls or small harbors and also along canals and rivers, the machine is mounted on any ordinary barge, being moved

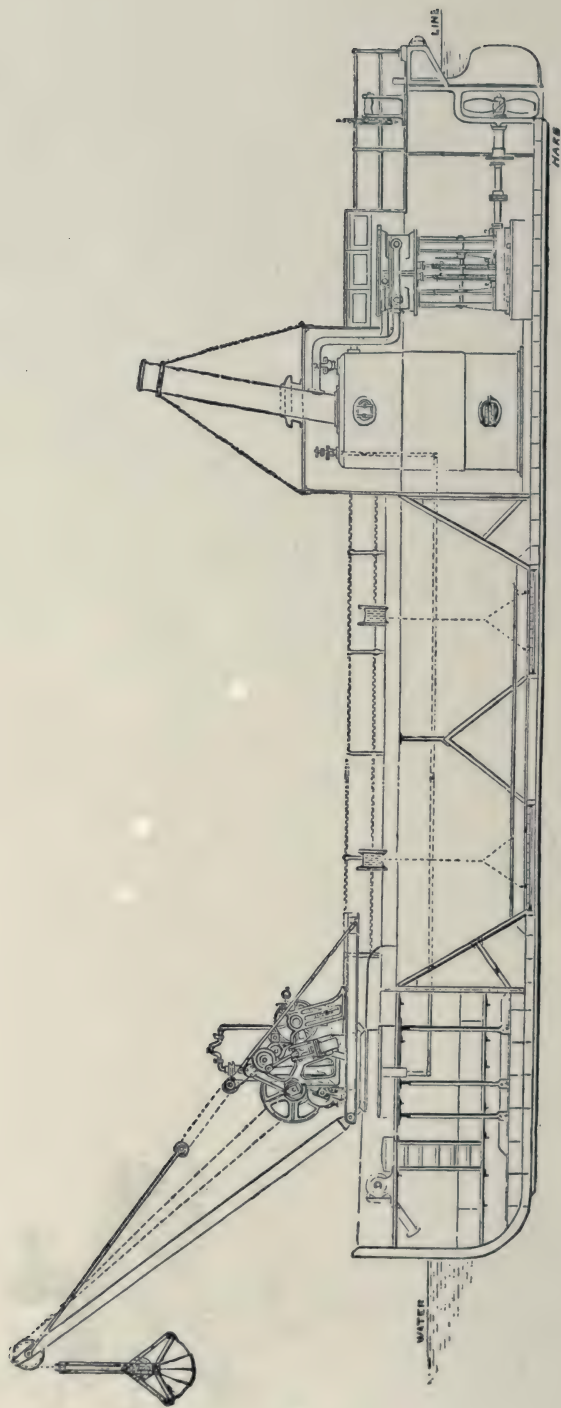

Fig. 48.—English Grab Bucket Dredge.

from place to place by tugboats. The barge can be made in the shape of wooden floats similar to those used in America, or may be constructed in the shape of the hull of a boat with a hold amidship for carrying materials or goods. The dredging apparatus can also be mounted upon a double cylindrical iron pontoon, as is done on the improvements of the Nile River. When the dredge is employed on work where the materials are directly deposited along the sides of the excavation, and it must be moved continuously from place to place without the help of tugboats, then the apparatus is mounted upon a self-propelling boat. The propelling apparatus may consist either of paddle wheels or screw propellers. When the dredge is moved by means of paddle wheels, as a rule, only one wheel at the stern of the boat is used, while the dredging machine is located at the bow. In such cases only one boiler is used and it is located in the hold near the wheel, the steam being carried to the hoisting engine by means of pipes. A machine mounted in this manner is preferred when necessary to have one of very light draft and small height, so as to navigate readily in very shallow waters and easily pass under bridges. The boat can be moved also by ordinary screw propellers. Then both the digging and propelling apparatus are mounted at the stern. The boiler is located either on the turning platform of the crane and the power for the propeller is transmitted by means of gearing and shafting. However, the propelling and digging apparatus may be independent of one another; then the machine is provided with two sets of engines and steam is supplied by a stationary boiler. In the machines of this type the crane with the digging bucket is located aft. The boat can be constructed of wood or iron when built to navigate in deep waters or carry the materials outside the harbor. The boat can be constructed with a hold for carrying the materials or with hoppers closed by doors at the bottom, where the materials are temporarily deposited in order to be transported and dumped in deep waters. Thus the machine will act like any other hopper dredge of any type, but since the efficiency of the English grab dredge is very limited, the hoppers also are made of small capacity, very seldom exceeding 500 or 600 tons. These machines are employed in the English Colonies, especially Australia. Fig. 48 represents an English grab bucket dredge of the hopper type with separate boiler and propelling apparatus as used in harbor works. To increase the efficiency of the machine two dredging apparatus are used, mounted one at the

stern and the second at the bow of the boat; steam being provided by a stationary engine located amidship. This type of dredge is preferred by South American engineers and contractors in the improvements of harbor and rivers. (Fig. 49.) At Liverpool was once employed a hopper dredge provided with four grab dredging apparatus of the Priestman type.

There is a large variety of buckets used on a grab dredge, but for the sake of classification they can be grouped into two types, namely, the clamshell and orange peel buckets.

The clamshell bucket derives its name from its shape, resembling the shell of a clam. The scoop or bucket is divided into two segments pivoted at their upper inner corners

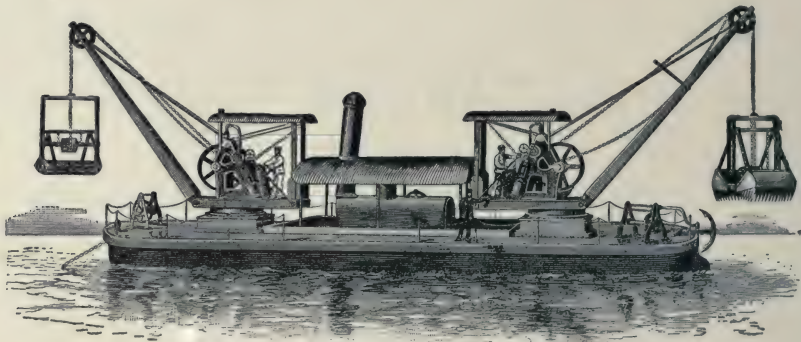

FIG. 49.—South American Grab Dredge.

and is supported, raised or lowered and opened or shut by means of chains passing to proper winding drums on the deck of the boat. The dipper, when in motion, in old machines, was steadied by a pair of long poles securely fastened to it and passing through rings or ears fixed at proper points on the boom. Improved models of buckets have made the guide holes unnecessary for dredging purposes, although this old arrangement is still found on dredges of small capacity.

The bucket, as a rule, is constructed of two steel scoops, pivoted together at their upper inner corners, arranged so as to open and close at will, and forming when closed an ordinary bucket for the raising of the materials from the bottom. The scoops forming the bucket are made of different shapes, depending upon the quality

of the material to be dredged. When the scoops are made of steel plates with sharp edges, we have a closed solid bucket convenient for working through such loose materials as quicksand and mud. For working through clay a bucket in which the edges of the scoops are provided with tines, Fig. 50, is considered the most suitable. For dredging through hard sandy material the edges of the scoops are furnished with interlocking tines set close together. Finally for raising boulders, gravel, and blasted débris an open-tined grab is used built in the manner shown in Fig. 51. The buckets herewith represented are those constructed by Messrs. Rose, Downs & Thompson, Ltd., being similar in their outlines to others built by European manufacturers. In America

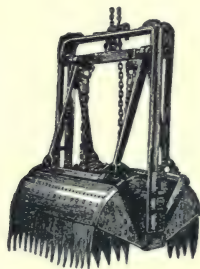

FIG. 50.—Grab Bucket for Dredging through Clay.



FIG. 51.—Grab Buckets for Gravel and Boulders.

only the solid closed bucket is used. This is due to the fact that there is a tendency here to use buckets of as large dimensions as possible, hence the penetration into the soil is accomplished by means of the great weight of the bucket itself, instead of being due to the shape and arrangement of the tines located at the edges of the scoops.

The clamshell bucket has an overhead iron rectangular frame. At the lower end of this frame are pivoted the two parts of the bucket, and the cross-head piece regulates the chains. These iron frames, together with the manner of attaching the two parts of the bucket to the frame, and the device for opening and closing the bucket, form the chains of the numerous patents.

Owing to the fact that the efficiency of the machine is estimated at one bucket per minute, American contractors have rapidly

increased the size of grab bucket dredges. Thus in the grab dredge used at Buffalo Breakwater and described in the following chapter the bucket was constructed with a capacity of 12 cu.yds. English manufacturers usually build buckets of four sizes, varying from $\frac{1}{3}$ to $1\frac{1}{2}$ cu.yds. capacity. The small efficiency of the English machines compared with the American is due to the different manner in which the dredging machines are mounted. Handling great weights the small English vessel would easily capsize, hence the buckets are made of small capacity.

The other form of bucket used in connection with the grab dredge is the orange peel bucket. This derives its name from the fact that when the bucket is closed it is of hemispherical form and



FIG. 52.—Orange Peel Bucket, Open. FIG. 53.—Orange Peel Bucket, Closed.

closely resembles the peel of half an orange. The bucket consists of three or four triangular blades and when closed forms a tight hemispherical receptacle for the excavated materials. When open the blades, provided with steel points, resemble sharp spades which are well adapted for penetrating hard materials. The blades are so adjusted that the maximum digging effect is produced with but a slight tendency to lift the bucket when closing. Horizontal arms are riveted to the blades, and their inner ends are attached to a central block, while the outer ones are hinged to vertical connecting-rods, pivoted at their upper ends to the upper center block. The power wheel for closing the bucket is fastened to the lower central block, and is somewhat eccentric in shape, so that it gives its maximum power just as the bucket begins to close. The bucket is well braced, and the shaft is extended on either side to receive

the cams to which are attached the power chains. The capacity of the bucket varies from 1 cu.ft. to about 10 cu.yds. Figs. 52 and 53 represent one of the orange peel buckets as built by the Hayward Company of New York.

The orange peel bucket is seldom used for dredging purposes while the clamshell bucket seems to be in favor with engineers and contractors. However, grab dredges with orange peel buckets, are used in the improvements of small rivers in which the dredged materials are deposited on both shores. For such work, however, the dipper dredge would be more efficient and economical. The grab dredge is the machine for great depths, and it is only under such conditions and when no other machine could be employed that the grab dredge can be used to great advantage.

Grab buckets, both clamshell and orange peel, are now designed to pick up hard materials, such as rocks and stumps. Some of the best designs will hold so tenaciously to a stump as to pull it loose. The fact that such dredges will do this work in deep water means a decided advantage.

The bucket of the grapple dredge can be operated in two different ways—either by a single or a double line. When one line is used this performs all operations of opening, closing, raising and lowering the bucket, while when two lines are employed, one is for closing and hoisting the bucket and the second for opening it.

With a single line, it passes over a sheave at the top of the boom to the drum of the hoisting engine. The chain, after passing through a hole in the fixed discharging hook, which is suspended from the boom head, is wound around and fixed to a sheave within the bucket. The operation of the machine is very simple; the bucket is lowered open, and the action of raising closes it. When raised the discharging hook opens the bucket, which empties and is then lowered for a fresh operation. The discharging hook is suspended either by chains or wire ropes or by bars; in either case they are capable of adjustment so as to regulate the height of discharge. There is on the market a very large variety of discharging hooks which together with the



FIG. 54.—Cooper & Holdsworth's Single-chain Attachment.

attachment of the hoisting rope form the claims of the numerous patents, which are generally known by the name of the various inventors. Fig. 54 shows the single-chain attachment to a whole-tine bucket of the Cooper & Holdsworth patent.

To operate the dredging bucket by the single-line method seems at first simple and convenient. But when it is considered that all the strain is thrown upon only one line, which is more liable to break while the machine is working and possibly when the bucket is under water, thus requiring the costly assistance of divers to recover it, this method has decided drawbacks. Another objection to the single-chain method is the fact that in order to discharge the bucket it is necessary to raise it to a certain fixed height, regulated by the distance of the opening gear or hook from the boom head, thus when a false lift is made the bucket must be brought to this fixed height before it can be reopened. A favorable consideration is that a single line does not require a special boom, but it can be readily attached to the boom of any existing crane.

In the double-line system the bucket is suspended by two lines, one called the closing or hoisting line and the other the opening line. The latter is held in tension while the former is being lowered, and can be stopped to allow the dredgings to be discharged, this being done by allowing the entire weight of the bucket to come upon the opening line. The engine operating the lines can be provided either with one or two drums. In the latter case each line is attached to its own drum and its movements are regulated by the operators by means of levers. But when the hoisting engine is provided with only one drum the opening line is connected by a series of sheaves to a weight moving in a vertical slide against the boiler. As the bucket is lowered this weight is raised, thus keeping the bucket open by the tension on the opening line. The total force exercised upon the material to be lifted by the grapple dredge, being the weight of the bucket plus the energy of descent, it follows that in this kind of machine, this must be minus the effect of the counterweight, which is seldom less than 1 ton and for deep lifts as much as 4 tons. By avoiding the use of weights to take up the slack of the opening line, the whole energy of the bucket in its descent is available to excavate the material, thus enabling a greater cut to be taken. American manufacturers, as a rule, build only grab bucket dredges provided with the double-line system, each line

being controlled by a drum of an ordinary double-cylinder-double-drum reversible engine.

The manner of operating the grab bucket by means of the double-line system is very simple. When the bucket is lowered to its work both lines run out freely, being kept from overrunning by a brake; thus the full energy of the falling bucket is employed in embedding itself in the material to be lifted. As the bucket can be opened or closed in any position, in submarine works in case the bucket becomes fastened to the bottom, it can be instantly opened to clear itself and another lift taken without further raising the bucket.

There is no limit to the depth at which the grab bucket dredge can be employed. For ordinary navigation purposes a depth of 30 to 35 ft. is the limit of dredging, but at such a depth other dredging machines will give perhaps better results. It is, however, in deep dredging that the grab dredge finds its greatest usefulness; thus, for instance, the dredging for the Buffalo breakwater in 90 ft. of water was very successfully done by the clamshell bucket dredge "Finn MacCool" illustrated in the following chapter. It is also used for sinking cylinders, shafts and digging pearls, corals and auriferous soils from great depths.

CHAPTER XXII

DESCRIPTIONS OF CLAMSHELL DREDGES

THE clamshell dredge "Finn MacCool," the dredge illustrated in Fig. 55, was employed on the extension of the Buffalo breakwater, and was operated very successfully under adverse conditions. The great depth of water, the nature of the material and the large

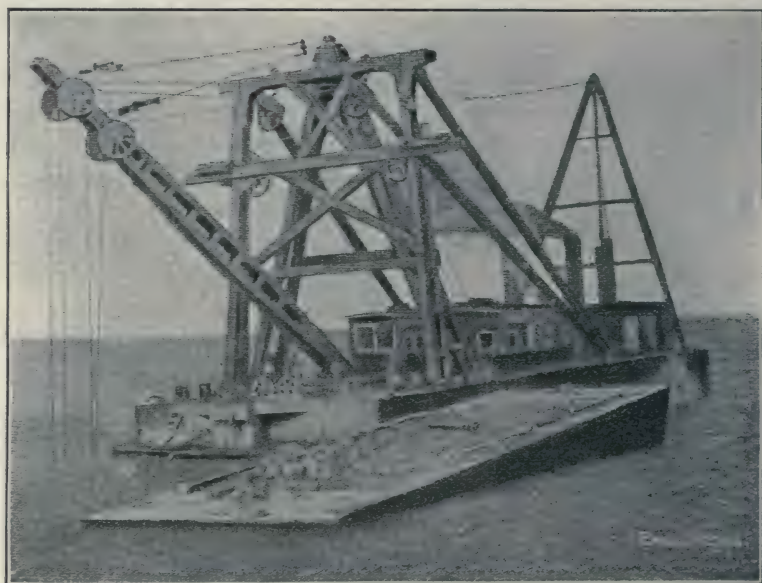

FIG. 55.—Dredge "Finn MacCool."

amount of excavation indicated that a large clamshell dredge would be the machine best adapted for the work. It was, therefore, decided to employ a clamshell dredge, and the contract for such a machine was awarded to the Osgood Dredge Co. of Albany, N. Y., by Hughes Bros. & Bangs, the contractors for the breakwater. The capacity of the bucket was fixed at 10 cu.yds., and the hull and machinery were designed with this capacity as a basis.

The hull was made entirely of wood, 120 ft. long, 40 ft. beam, and 12 ft. 6 in. deep. The length given does not include a moulded bow and stern of falsework, which were added to make the dredge tow easier, and which increased the total length to 160 ft. The A frame was 50 ft. high above deck and the boom 65 ft. long. There was a single spud at each end of the hull, but these spuds instead of extending to the bottom, acted simply as attachments for the anchor ropes by which the machine was really held in position. The usual manner of anchoring dredges working in water too deep for spuds is to run the anchor line from the level of the deck. With a beam wind and heavy sea several anchors are usually required to hold the dredge in place, and these interfere seriously with the free handling of scows and tugs alongside. It was therefore desired to remedy this fault in constructing the present machine.

The dredge was provided on each side with a spud, 3 ft. square, which extended 25 or 30 ft. below water. At the bottom of each spud there were three sheaves, two fixed across the spud and one fore and aft. On the deck, close to the spud, were located three other sheaves. The anchor lines passed from the drums over the sheaves on deck, down along the sides of the spuds, through guides cut in the spud wells, and under the sheaves in the bottom of the spud out to the anchors, some 300 ft. away. This arrangement held the dredge with anchors in six different directions, the line of which were 25 ft. under water, giving free access to scows and the largest tugs to approach the dredge from all directions. In actual operation the center bow anchor was not used, as it was not required, and its removal did not interfere with the free operation of the bucket. The remaining five anchors have proved their ability to hold the dredge on the line of the work with a strong beam wind and heavy sea. The dredge moved backward along the line of the cut, the movement being accomplished by hauling in on the center stern anchor line. A patent for this form of anchor attachment was secured by the Osgood Dredge Co.

Turning now to the operating machinery, the main engine, placed amidship, operated the dredge bucket. This was an 18X 24-in. double-cylinder engine, with Stephenson reversing gear, and was compound geared to two 60-in. drums, with gear faces 12 ft. in diameter and double frictions of the V type, the male V was of iron and the female lined with lignum vitæ. The male V was hollow, and to keep the friction faces cool, water was

circulated through them. The frictions were set up by steam compressors, so arranged as to apply pressure graduated at the will of the engineer. From the drums four 1½-in. 37-wire strand plow-steel cables ran to the clamshell. This clamshell bucket was itself of rather novel construction, as shown by Fig. 56. The bucket was of 10 cu.yds. capacity, and when empty weighed over 30,000 lbs., and as the great depth of water precluded the use of poles, some special precautions were taken to prevent it from twisting



FIG. 56.—10-cu.yd. Clamshell Bucket of the Dredge "Finn MacCool."

the cables together. The method adopted, as seen from Fig. 56, was to employ two sheaves, one placed on each side of the bucket, and to operate the bucket by two opening and two closing cables. As these four cables ran over four sheaves on the boom, and the cables were made in pairs, with right- and left-hand lay, there was no tendency of the bucket to twist.

The secondary engines were two in number, each being a double-cylinder engine, and one being placed aft and the other forward of the main engine. The forward engine was 10×12 in. and drove three friction drums for handling the forward anchor lines and

six upright capstans on deck for handling lines and scows. The stern engine had 8×10 in. cylinders and drove the three friction drums for the stern anchors and two capstans on deck. Each capstan was fitted with independent friction, brake and rackets.

Steam was supplied to all three engines by two Roberts water tube boilers. Each boiler had 46 sq.ft. of grate surface and 1200 sq.ft. of heating surface and was built for 250 lbs. steam pressure, although they were run at 125 lbs. pressure. All the engines were piped to a Wheeler admiralty condenser and also to a free exhaust pipe, so that they could be run either condensing or non-condensing.

The coal consumption was estimated from four to five tons per day. The machine was operated by a crew of ten men. In regard to the efficiency of the machine it worked one bucket a minute in 65 ft. of water. Its average work was the loading of ten or eleven scows per day, the capacity of each scow being about 400 cu.yds. The dredge often loaded scows in 30 and 40 minutes, and in soft clay repeatedly loaded a pocket containing 60 cu.yds. with four buckets in 4 minutes in 60 to 70 ft. of water.

The dredge has worked very satisfactorily, working quickly, easily and smoothly, with plenty of power and abundance of strength in all its parts and with great steadiness.

The Clamshell dredge "Champion"—a new departure, namely the opening and closing of a clamshell bucket by means of compressed air, was designed by Mr. W. H. Arnold and used in the dredge "Champion" of the W. H. Beard Dredging Co. of New York. It was described in the Engineering News, May 2, 1901, from which the following condensed description was taken:

The pneumatic clamshell dredge bucket is an innovation which promises to have a wide field of usefulness. As engineers familiar with this type of dredging apparatus know, the ordinary chain-closed clamshell has serious defects. The bucket can be closed only after it has come to rest on the bottom, and the pull of the closing chains reduces the effective digging weight of the buckets owing to their lifting action. To avoid these objections several attempts have been made to devise buckets closing by the action of liquid pressure in a cylinder, but so far none of these devices has gained much favor. The bucket illustrated here is one of the latest of the devices and has given very good results. In it the opening and closing of the bucket is performed by air pressure operating through a cylinder and piston, the action being wholly

independent of the hoisting chains and of the position of the bucket.

The construction of the bucket is seen from the sectional drawing, Fig. 57. The central part of the bucket is the frame *A*, which terminates at the top in a fork *B*, and at the bottom in a cylinder *C*; between the arms of the fork is pivoted a compensating bar *D*, to the ends of which are attached the hoisting chains, and at the bottom of the cylinder there is a wedge-shaped cylinder-head guard *E*. The compensating bar serves to keep the bucket vertical in descending, while the cylinder-head guard serves as a means for anchoring the bucket or for holding it while filling in a fixed position in the material to be removed. The shells *F F* of the bucket are hinged to the frame by four bucket arms *G*, and are also hinged to the crosshead *T* by the triangular connecting links *H*. This crosshead is keyed to the top of the piston rod and slides between interior guides on the two members of the frame.

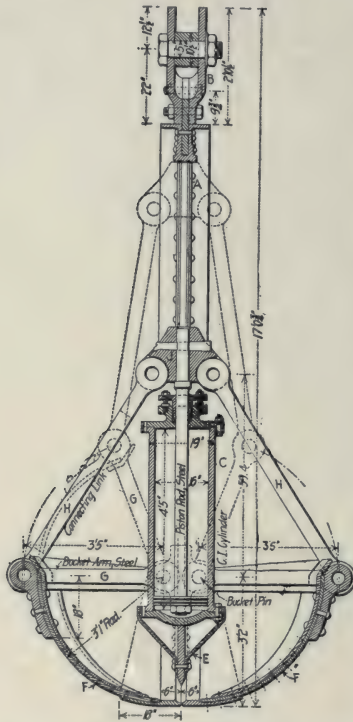

FIG. 57.—Sectional View of the Clamshell Bucket "Arnold."

In operation, the jaws or shells of the bucket are both opened and closed by the positive action of the air pressure upon the bottom or top of the piston. The air is conveyed to the cylinder from the receiver on the dredge through a double-barreled or Siamese hose arranged as described later. It will be observed from the drawing that the opening and closing mechanism is wholly independent of the devices by which the bucket is hoisted and lowered, so that it may be closed at any point in its vertical travel. Furthermore, it will be seen that when the bucket rests on the bottom its whole weight is effective for digging, the hoisting chains remaining slack until the jaws are closed.

The dredge (Fig. 58) is of the ordinary flat-deck type and in appearance is similar to any other clamshell dredge, the only difference being a hose reel on the boom and the unusual installation of air compressor and receiver.

The problem of handling the hose during operation was a somewhat critical one. It was necessary, of course, that the hose should freely follow the bucket in its descent and as freely and quickly be gotten out of the way in the ascent of the bucket. It was highly desirable also that these operations should be automatic. The

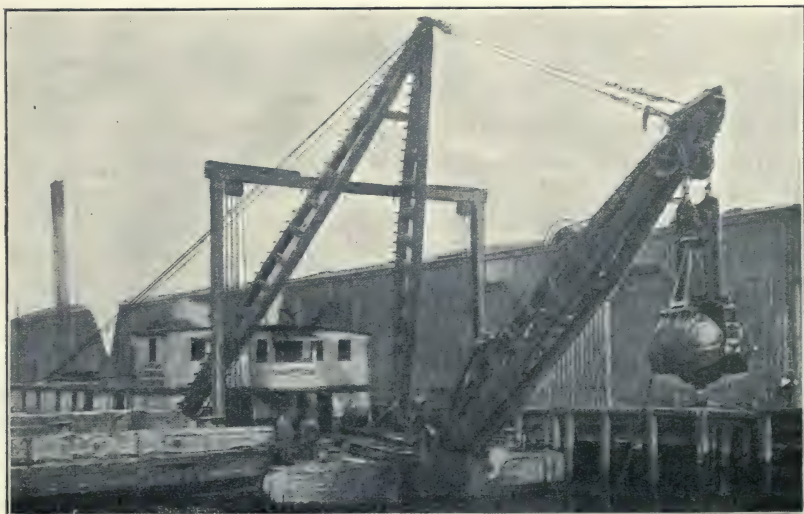

FIG. 58.—Dredge "Champion."

solution of the problem was exceedingly simple. A vertical hose reel with a hollow shaft or axle is carried on bearings on the top member of the boom. From the receiver two lines of iron pipe pass up the boom and terminate in the ends of the hollow shaft. The double hose has connections tapped into the shaft to admit the air to it. In operation the hose is unwound from the reel by direct pull when the dipper is descending. This action, of course, rotates the reel and this rotation winds up a cable attached to a counterweight which slides up and down the boom on an interior track. When the bucket begins to ascend and releases the tension on the hose, the counterweight acts by gravity to unwind the counterweight

cord which rotates the reel in the reverse direction and winds the hose onto it as fast as it comes out of the water. Both the unwinding and rewinding actions are wholly automatic and require no particular care on the part of the operator.

On the dredge "Champion" a double or Siamese hose was used, one barrel of which supplied air to the bottom of the piston and the other to the top of the piston. A pressure of 100 lbs. per sq.in. was used. The admission of the air to the cylinder and its exhaust were controlled by a three-way cock on each of the two lines of pipe leading to the hose, these cocks being placed in the operator's cabin close to the hand of the dredge operator.

The main dimensions of the bucket used on the dredge "Champion" were: Capacity, 3 cu.yds.; diameter of cylinder, 16 in.; area of piston, 200 sq.in.; length of stroke, 4 ft.; working pressure of air, 100 lbs. per sq.in.; total pressure on piston, 20,000 lbs.; total weight of reciprocating parts, 9000 lbs.; total closing force on material, 29,000 lbs.; actual weight of bucket, 24,000 lbs. This bucket was designed for hard digging. For soft material a larger bucket is employed and for handling blasted rock the bucket shell is replaced by grapples.

The advantages claimed for this form of clamshell over chain-closing buckets are: Closing and opening independent of use of frictions; bucket can be lowered into scow well and dumped on the doors without dropping the load; a gain of about 10 ft. in width of cut is made owing to the fact that the chain-closed bucket will fall off in opening. The entire weight of the bucket is on the bottom while closing, and finally the ability to close the bucket at a given depth enables the dressing off of the bottom of the cut at the required depth without excess excavation.

CHAPTER XXIII

TRANSPORTATION OF THE DÉBRIS. CONVEYORS, BARGES, ELEVATORS

THE dredged materials are disposed of in different ways. They can be used for filling lowlands, for regulating the shores of the river or canal alongside the improvement, and when they cannot be utilized in any other way, are dumped into deep waters. In any case the débris must be transported a certain distance, which varies according to the local conditions. There are different means of transporting the dredged materials, depending upon the machine employed and the method of disposing of the débris. Thus, for instance, when the machine used is not of the hopper type, or when the dredge itself does not transport the materials removed from the bottom, the débris is conveyed to the dumping place either by conveyors, pipes, or by means of barges or scows.

Belt Conveyors. In the description of the low-tower ladder dredge used in the improvement of the Fox River, Wis., given on page 86, was illustrated the method of conveying the débris from dredge to land by means of a belt conveyor. This method, which was used many years ago in connection with land dredges at Tabernilla, Panama, under the French Administration, has been very recently introduced in this country for the transportation of the débris removed from the bottom of rivers by means of ladder dredges. This method is so simple that the description of the one given will be more than sufficient to explain it.

Pipe Conveyors. Another manner of transporting or conveying the débris from the dredge to the nearby lands is by means of pipe conveyors. These are used in connection with the high-tower ladder dredges and with the hydraulic and pneumatic dredges. In the former case the débris descends through the pipe by gravity; in the latter it is under pressure and consequently they can be discharged at a point higher than the dredge itself.

The following description of a pipe conveyor used in connection

with a high tower dredge in the excavation of Suez Canal, taken from Spoon's Engineering Encyclopedia will serve to illustrate this method of transporting the débris from the dredge to land.

At Suez the ladder dredges were provided with high towers and discharged their contents into an extra long chute. See Fig. 59. The length of the chute from the center of the dredge was 230 ft. with an elliptical cross-section $2\frac{1}{2}$ ft. wide and 5 ft. high. The height of the upper tumbler of the ladder was 48 ft. above the water. Two centrifugal pumps supplied water to facilitate the discharge of the spoil. To support the chute for its entire length a latticed cantilever beam was constructed which rested both on the dredge and on an iron pontoon which was placed about one-third of its length from the dredge. Two uprights which stiffened the chute

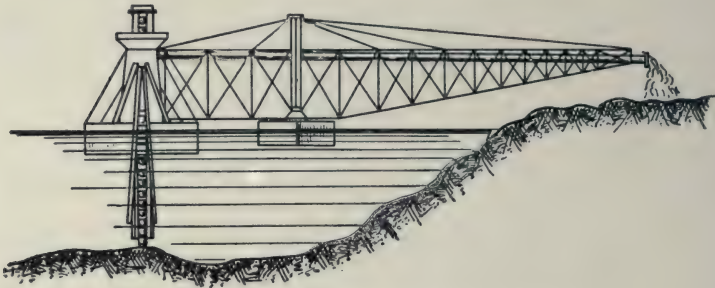

FIG. 59.—Ladder Dredge with Pipe Conveyor.

were not fixed to the pontoon, but rested on beams placed longitudinally on the pontoon. A horizontal hinge coupled the chute to the dredge and allowed its inclination to be altered. To permit changes in the inclination of the chute, the uprights which supported it were made telescopic. The chute was lifted by two small hydraulic presses worked by hand.

Observations made on the passing of difficult materials through chute showed the following results. Only fine sands were excavated and they passed easily down a chute inclined 1 in 20 or 25 if mixed with a quantity of water equal to about one-half their own bulk. When the chute has an inclination less than 1 in 25 the water separates from the sand which is thus deposited all along the chutes in layers of continually increasing thickness. The addition of a larger quantity of water does not seem to make the chute more effective, and it is necessary to stir the sand with a shovel. When the sand

contains shells, they are deposited in the chute. The shells create around them deposits of sand which continually increase and must be removed either with shovels, or by increasing the inclination of the chute. A greater volume of water is of no avail. With various degrees of fineness of the sand and mud, it was found that different inclination of the chute were required.

Mud behaves very much like sand. If it is sufficiently soft to mix with water it will pass down a chute set with very slight inclination. The very soft mud at Suez, such as that from the old channels previously cut through the clay ground, does not require the addition of any water in the chute. With clay it is quite different; the addition of water washed away only a very small quantity of the material, and hardly breaks up the lumps. If each lump of clay were to slide perfectly straight down the chute, all would work well; however, a lump winds about and soon stops, and the contents of the next bucket drives it on 5 or 10 ft., and this increases the trouble, until the mass gets to be 12 or 16 in. in thickness and reaches to the top end of the chute, when the contents of the succeeding buckets seem to break it up, and the mass descends quietly and regularly in pieces of about 3 to 6 ft. length. The chutes for clay are inclined from 1 in 12 to 1 in 16. With an inclination of 1 in 20 the work is more regular. When the clay is mixed with sand the surface acts like a rasp, because the water washing away the clay leaves the grains of sand, and their grinding and cutting are detrimental to the chute.

Experience has thus shown that while a considerable supply of water must be added to sand, it is not so for mud or clay, to which just enough water must be added to moisten the mass. Jets of water have not given good results; they merely wash down the points against which they are directed and do not break up the lumps. In dredges with chutes 230 ft. length an endless traveling chain is employed, driven by the engine and furnished with a series of scrapers to carry the clay down the chute. Generally the greatest difficulty with all kinds of spoil is in passing through the first 40 or 50 ft. of the chute. When once the material has passed this with any given inclination, it continues moving on down the same inclination without any further difficulty.

Very often the materials removed from the bottom by hydraulic dredges are used to fill up lowlands near by, and are transported by means of a long line of pipes. The pipes used are of different

shapes and sizes to satisfy local conditions, but generally they consist of sections of pipes bolted together and supported by floats of any design. The various sections of pipes are joined together in some way so as to permit the whole line to adjust itself to tides, currents and other circumstances.

The following description, taken from Engineering, will serve to illustrate the method of conveying the materials from dredges to land by means of a pipe line. It was used in connection with the hydraulic dredge "J. Israel Tarte" designed by Mr. W. Robinson for deepening the channel through Lake St. Peter in the River St. Lawrence.

The form of pipe line adopted is that of a central conduit 36 in. in diameter, carried by two cylindrical pontoons or air chambers 42 in. diameter, the three being bound together by truss-frames clamped upon them as shown in Fig. 60, Cut A. In this way no bolts or rivets are put into the air chambers, and they may be readily taken apart.

The pipes were made up in 100-ft. sections, and four sections of 50 ft. were made with the idea of putting them in that part of the pipe where greater flexibility was required. It was found, however, that these 50-ft. pipes did not stand the sea as well as the 100-ft. sections and that, moreover, sufficient flexibility could be had without them. They were accordingly joined together and converted into 100-ft. sections.

The joints connecting the 100-ft. sections were at first made by uniting them with a forged-steel pin connection over the rubber sleeve, thus relieving the rubber sleeve of all strain due to tension of the pipe and permitting the required angular movement. These joints were not strong enough, and were found to be too rigid in wave-action and caused heavy strains to be set up, which broke some of the joints. They were temporarily repaired for the first season, and during the winter 1902-03 new joints of special construction were devised by Mr. Robinson on the ball-and-socket plan to permit of universal movement to a moderate degree, and also fitted with draw-bar springs to allow of variations in length due to surging and pitching. The ball-and-socket principle was embodied, not in the pipe itself, but in a strong steel frame above the pipe, which was connected by rubber sleeves in the usual manner. This has proved entirely successful, and the practical result is that the dredge is capable of continuing at work in all but the heaviest weather.

The general construction of the pipe line and joints are illustrated in Fig. 60, Cuts *B*, *C*, and *D*. The ball end of the joint is solidly riveted to the frames on the pipe, while the socket is fitted to slide in a casing or frame, and its movement is resisted by springs as shown. These springs are two in number and are heavy car springs. They

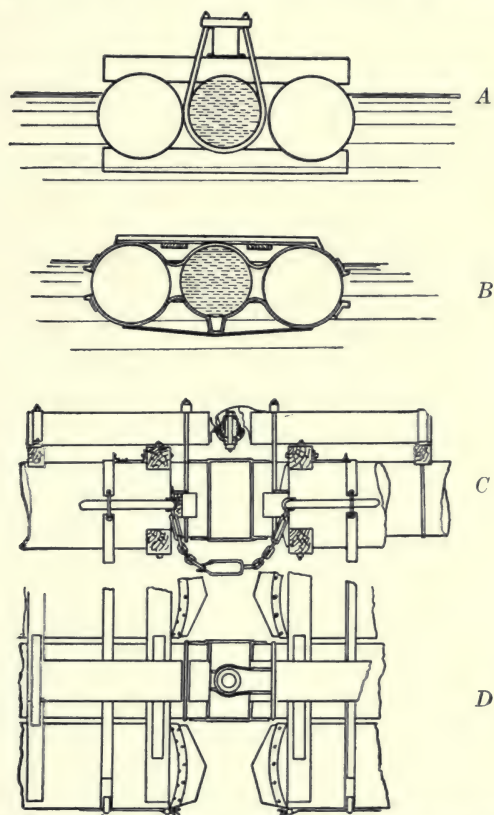

FIG. 60.—Pipe Line Conveyor of the Dredge "J. Israel Tarte."

are $6\frac{1}{2}$ in. in diameter and 8 in. long and made of round steel $1\frac{1}{2}$ in. in diameter. The springs are carried between spring-plates, resting against stops in such a way that the springs are compressed for either thrust or pull of the draw-bar, and the whole arrangement is built of steel in the very strongest manner, and each joint is strong enough vertically to carry half the entire weight of the pontoon upon it. In other words, should the entire buoyancy be removed

from one pontoon for 50 ft. of its length by the trough of a wave, its weight could be rested upon the adjoining pontoon with safety.

No anchorage is used at any intermediate point of the pipe. It is attached at one end to the dredge and at the other by a short cable to scow, the entire 2000 ft. being free to drift as it pleases. The scow is fitted with a steam winch, by which its own anchorage is controlled. It has two anchors with wire cables $1\frac{1}{4}$ in. diameter and 2000 ft. long. These can be hauled in and paid out as required and this movement serves both to distribute the material, to avoid piling up above the surface of the water, and also to regulate the tension of the pipe when the dredge is making a very wide cut. In places, when the cut is 750 ft. wide the pipe tightens up to almost a straight line when the dredge is at the far side. The scow anchorage permits considerable freedom of movement, and, when necessary, the operator on the scow pays out on his anchorage to relieve and permit the dredge to make the cut.



FIG. 61.—Open-hold Barge.

Scows. The scows used for the transportation of the dredged materials are of different types, which for sake of classification can be grouped in open-hold scows, deck scows or floats, and dumping scows. Each group can be subdivided again.

Open-hold Barges. The ordinary barges or lighters used for the transportation of various materials along canals and rivers can be also employed for carrying away the dredged débris. As a general rule these vessels are not the most convenient and economical, yet there are cases in which even these barges can be employed with advantage. In the open-hold barges the material is deposited directly on the bottom of the boat, the floor being formed by planks placed longitudinally and resting on the keelsons—Fig. 61. The empty space included between the said platform and the sides of the boat determines the capacity of the vessel, which capacity varies considerably. This type of barge is very seldom used for the transportation of the dredged materials, owing to the difficulty of removing the débris from the bottom of the scow. It is only used in the improve-

ments of rivers and canals in connection with the ladder, dipper and grab dredges, when the material must be transported to a certain distance and raised again by some machine. In such a case the sides of the boat prevent the scattering of the material under the stirring action of the lifting machine; but the platform forming the bottom of the boat is subjected to hard usage and easily wears out.

In regard to the shape, the open-hold barges are built with flat bottoms to insure steadiness and light draft, thus, too, making their construction cheap. In barges of large dimensions the horizontal beams or keelson are subjected to unusual stress, and it is worthy of note that in the barges used for the transportation of the rock excavated from the site of the new Pennsylvania Station in New York city, all the beams of the floor of the barges, under the double action of the pressure of waves below and the material above, broke along the line of neutral axis. They showed a seam as long as the beam itself, while the beam remained unaffected on the upper and lower part, in apparent contradiction to the well-known theory of tension and compression in the two parts of the beams.

Deck Scows or pontoons. These are used for the transportation of the dredged materials on rivers and canals, when the materials deposited on deck of the barges have to be raised to be sent to the dumping place. This type of barge is subdivided again into deck-scows proper, railroad floats and deck-scows with open boxes. The deck-scows are always built of rectangular design with flat bottom to insure light draft, and they are made of soft wood both in the frame and planking.

The deck-scows proper are used for the transportation of the dredged materials when they are deposited in skips which are lifted by derricks or cranes and unloaded again, either directly onto the ground or into cars to be conveyed to distant points. But this method of transporting dredged materials is not very common, and is used only under unusual conditions, as for instance on the Fonage Canal along the Rhône River in France.

When the dredged materials are used for filling lands some distance from the shore instead of using skips it is more economical to deposit the débris directly into railroad cars located on the deck of a scow. For such purposes the deck of the pontoon is provided with several parallel tracks upon which are placed the cars. After

all the cars have been loaded, the float is towed to some distant point and moored to a convenient place where there are tracks in continuation and flush with those located on the float. At the landing pier a locomotive pulls out one row of cars at a time and after the train is formed it is sent to the dumping place, while empty cars are replaced on the float and towed back to the dredge to be filled with dredged material. This method of transportation can be used only in connection with the dipper and clamshell dredges, and although it can be found convenient in some cases it has the great disadvantage that it is difficult to load the cars, part of the material falling between the tracks and must be removed by hand.

Deck Barges with Cargo Box. The dredged materials can be transported also on deck barges with cargo boxes, when the barges will be unloaded by means of clamshell or orange-peel buckets. This method of transportation is commonly used in connection with gravel and sand dredging for commercial purposes. The cargo box is formed by fitting side boards about 3 ft. high and arranging hopper ends, inclosing nearly all the deck area, leaving but a small space at each end for handling lines. The barges used for carrying sand on the Mississippi River are subjected to severe strains, and so several steel-deck barges have been placed in service by one of the largest sand companies on the river. These barges are 130 ft. long, 30 ft. wide and $7\frac{1}{2}$ ft. deep. A complete steel deck is fitted, and on this a wood box is arranged, by fitting timber side boards 3 ft. high. The deck beams are framed longitudinally so as to better care for the impact of the grab bucket, which is used with its cutting edges across the barge.

Dumping Scows. The transportation of the débris from the dredging point to the dump in high seas, when not made by the dredge itself, is done by means of dumping scows. These are usually composed of an ordinary deck scow with one large or several small holds having the floors formed by the trap doors. The débris is deposited into these compartments and when the doors are opened the contents fall out by gravity. It is more convenient to have the scow divided into many separated compartments instead of one large one. Such an arrangement will greatly facilitate the operation and prevent the great weight of the load from straining the mechanism controlling the doors.

Dumping scows are constructed of different shapes and sizes.

American manufacturers are building dumping scows of very large dimensions, not less than 200 ft. long and 40 ft. beam, divided into four or five compartments, each shaped as an inverted frustum of a pyramid with the floor formed by a trap door. This door is hinged at one side and at the opposite side is controlled by chains wound around a shaft, located on deck and parallel to the longitudinal axis of the scow. This shaft, through a system of cogwheels, is revolved either by a steam winch or by a capstan worked by hand power. When the dumping place has been reached, the brakes that keep the shaft in position are removed, the weight of the materials pressing on the floor of the compartments opening the doors and thus dumping the load. It is in closing the doors that either the steam winch or the hand capstan comes into play.

The European dumping scows as a rule are smaller than the American, but are built of a large variety of designs. They are generally provided with a central partition which divides the hold into two separate longitudinal compartments. The shaft for the opening and closing of the trap door is located on top of the central partition. The advantage of such construction is that the doors are smaller, consequently less strain is placed on the brakes which keep the doors fastened. Even these two longitudinal hoppers are usually subdivided into others, every one of them being in the shape of an inverted frustum of a pyramid. But the shape of these hoppers varies with the material to be transported; thus, for clay, the sides of the hopper should be kept as vertical as possible to prevent the material sticking and clogging the doors, as they would if the sides were inclined. For the transportation of fine sand and mud the bottom of the hoppers, instead of being provided with doors, have conic valves fitting circular openings. By simply raising these valves the materials will immediately escape through the openings.

Fig. 62, *A* and *B*, show the cross-sections of two different types of dumping scows employed on the construction of Suez Canal. These scows were constructed with flat bottom in order to have light draft; but when the material has to be dumped in deep water in the high sea the scow is constructed with a hull similar to any sea-going boat. Fig. 63, shows the cross-section of a dumping scow constructed to convey and discharge dredged materials into shallow waters. In such a scow should the trap doors form the floor as usual, and open downward, they would reach the bottom

and could not be entirely opened, thus preventing the discharge of the load. To avoid this the doors are placed on both sides of the scow and the hoppers are inclined outwardly to facilitate the descent of the materials, once the doors are open.

Dumping scows are tied one behind another by long lines, forming a tow composed of 3, 4 or 5, and towed to the dumping place

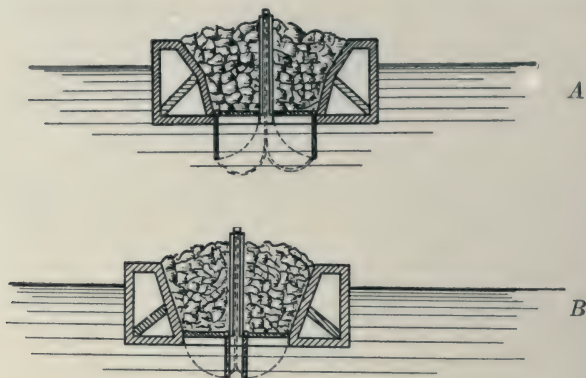

FIG. 62.—Dumping Scows used at Suez.

by a tugboat. But this method of hauling is not always possible, especially when the sea is rough, as the rolling of the various scows will disarrange the lines, causing loss of time and often injuring the scows. To avoid this, dumping scows are built in the shape of any ordinary sea-going vessel and are self-propelling. In the construction of the Suez Canal, in transporting material from the Canal



FIG. 63.—Dumping Scow for Shallow Water.

prism to the dump at the Bitter Lakes, some self-propelling dumping scows were used. They were provided with bottom doors, were 108 ft. long, with 23 ft. beam, carrying 160 cu.yds. of spoil and drawing 5 ft. of water. They were fitted with twin screws and a pair of cylinders placed end to end. The engines worked at high pressure without a condenser, with a tubular boiler at 120 lbs. pressure, using only fresh water. Whether loaded or light they

made a speed of 3 to 3½ miles per hour, and although built especially for the lakes they could be sent to sea. Their construction was simple and economical and it was found that the pressure engines were preferable to those of medium pressure, as being simpler, lighter and easier to keep in working order and consequently could be relied upon for continuous work.

To-day, instead of simple dumping scows, are built regular sea-going hopper steamers with a capacity of about 1000 tons, and able

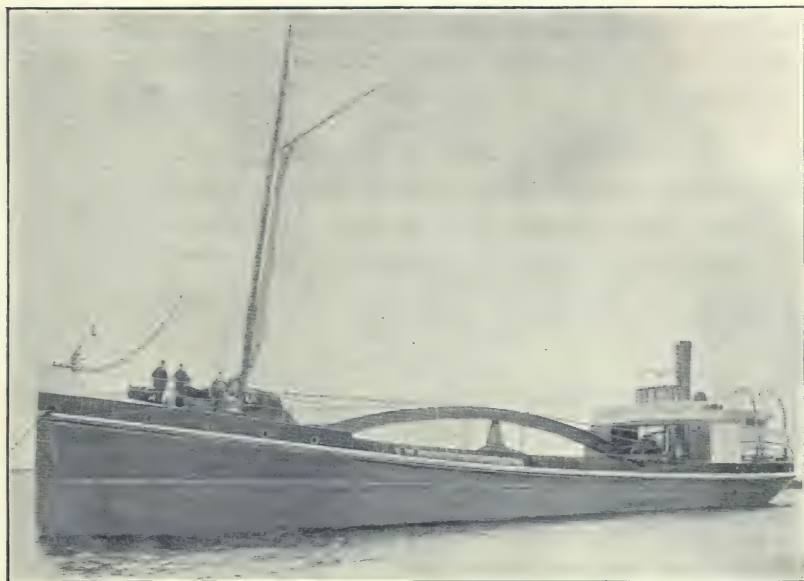

FIG. 64.—Sea-going Steam Hopper.

to navigate in any kind of weather. Fig. 64 shows one of these hopper steamers as built by the firm A. F. Smulders of Rotterdam, for the Russian Government.

Dumping scows are far more economical than the hopper steamers both in the original cost of construction and in the running expenses. For this reason contractors in the equipment of their plants will always prefer dumping scows to hopper steamers. The latter, however, are more reliable for continuous work and supply a rapid and uninterrupted means of transportation for the débris of the dredges which work day and night on river and harbor improve-

ments. These hopper steamers being very expensive, only governments and public corporations can afford to invest an enormous capital for the sole purpose of obtaining a better means of transportation. On account of the almost prohibitive cost of the steam hoppers, manufacturers have devised schemes to extend their utility. The propelling machines have been increased in power so that the steamer could be used as a tugboat; and in many cases with good weather prevailing have been used, even with a full cargo, to tow a line of dumping scows. Steam hoppers have been also supplied with fire-extinguishing pumps so as to be utilized as a fireboat. In such cases the steam hopper performs a double duty. Steam hoppers have

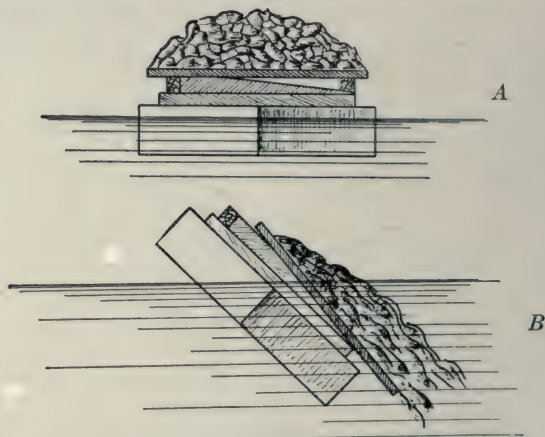

FIG. 65.—Dumping Scow with Sliding Platform.

also been supplied with a centrifugal pump and a suction tube, and thus have been converted into a sea-going hopper hydraulic dredge of small capacity, convenient for cleaning the quays and piers around the harbor. Finally the steam hoppers have been used for life-saving purposes and for helping vessels that are in distress. Thus the steam hoppers "San Demetrio" and "San Caledonio" built by H. Satre & Co. and used in the improvements of the harbor of Santander, Spain, on many occasions during the great storms prevailing in that locality have put to sea and helped numerous fishing smacks and steamboats.

Another type of dumping scow built on an entirely different principle was used for dumping rocks in the dyke construction at Newburyport, Mass.

The scow (see Fig. 65) is about $62\frac{1}{2}$ ft. long and 22 ft. wide; on this is placed a platform 32 ft. long and 22 ft. wide, which is arranged to slide on 8 roller ways inclined at an angle of 1 in 28, transverse to the axis of the boat. Between these ways there are three struts or braces, one in the middle and the others near the ends of the platform. The lower ends of these braces turn on a vertical bolt fixed to the deck of the boat and the upper ends abut against strong blocks fixed to the platform. These three braces are tied together by a rod attached to a lever which by a simple movement

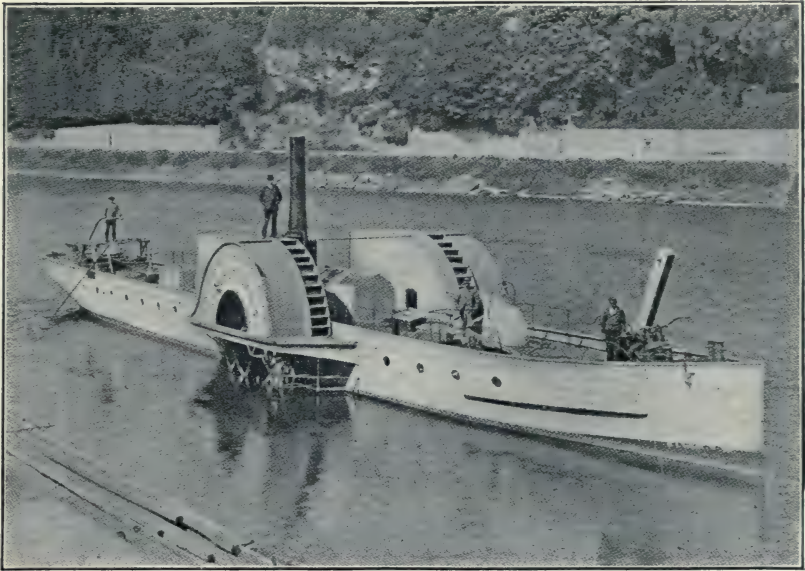

FIG. 66.—Sidewheel Tugboat.

releases the braces from their blocks and leaves the platform resting free on the rollers. Wooden guides keep the platform to its track.

The dumping operation is as follows: As soon as the braces are released the platform glides outward on the inclined track by reason of its load. After moving about $3\frac{1}{2}$ ft. it is checked by bringing in contact the blocks fastened one to the platform and the other to the deck of the boat. Under the change in the center of gravity the boat assumes the position shown in Fig. 65 *B* until the deck load is discharged, an operation consuming about 10 seconds.

As soon as the empty boat rights itself again, the workmen run the platform back into position and secure it there by the braces.

The tugboats used for towing scows are too well known to be discussed. They are generally screw propellers or sidewheel steamers of great efficiency and light draft. Fig. 66 shows a sidewheel steamer used for towing purposes in shallow rivers. Fig. 67 shows a screw propeller steamer built by the F. Smulder Co. of Rotterdam for towing scows in deep waters.

With the exception of the dumping scows the dredged materials transported by means of any other scow to reach its final desti-



FIG. 67.—Screw-propelled Tug Boat.

nation must be raised up. This is effected by means of different machines, namely, the bucket elevators, the derricks and grab buckets.

The bucket elevator consists as a rule of a land dredge, of the down-digging type mounted either on a fixed scaffold or on the platform of a truck running on tracks. The machine consists as usual of a ladder hinged to a tower at its upper end, while its lower end is supported by a boom. The ladder is provided with a double endless chain carrying steel buckets and revolving around two tumblers at the ends of the ladder. An engine providing power to the upper tumbler moves the buckets along the ladder.

The manner of operating this apparatus is very simple. The boat loaded with the dredged materials approaches the machine, the ladder is lowered so as to dig into the débris, the engine is then started, and the material picked up by the buckets ascends the ladder and in revolving around the upper tumbler drops into a chute. The machine may be either firmly mounted on a scaffold made up of heavy timber beams and located at some convenient point along the river shores, as in Fig. 68, or it may be mounted on a platform of a railroad car and moved along tracks placed

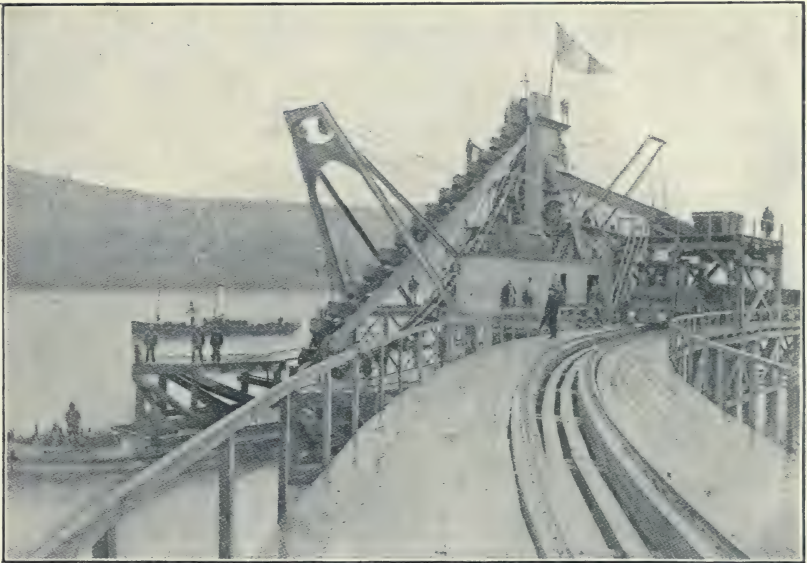

FIG. 68.—Bucket Elevator for Unloading Barges.

along the shores. In the former case the material when dumped from the buckets into the chute enter into bins and from them is discharged by gravity into cars and thus sent to its final destination. With the other method material from the chute is dumped directly onto the ground which is to be filled up. In this case, it is necessary to use a high tower so as to extend the chute in order to dump the material at more distant points.

Sometimes, especially when close to the shores, the river or canal is very shallow and a loaded scow could not safely navigate there; the elevators are then mounted on floats. Then the ladder

is placed at the center of the apparatus and is supported by two independent floats, each of them affording a firm support for one of the standards of the tower. Besides, the floats are connected together by a bridge provided with a gantry for raising the ladder. The scows enter the space between the floats, passing under the bridge. The unloading is very simple. The ladder that was raised to allow the scow to enter is now lowered into the hold, the machine is put in motion, and the buckets filled with materials travel along the ladder and dump their contents over the upper tumbler, dis-

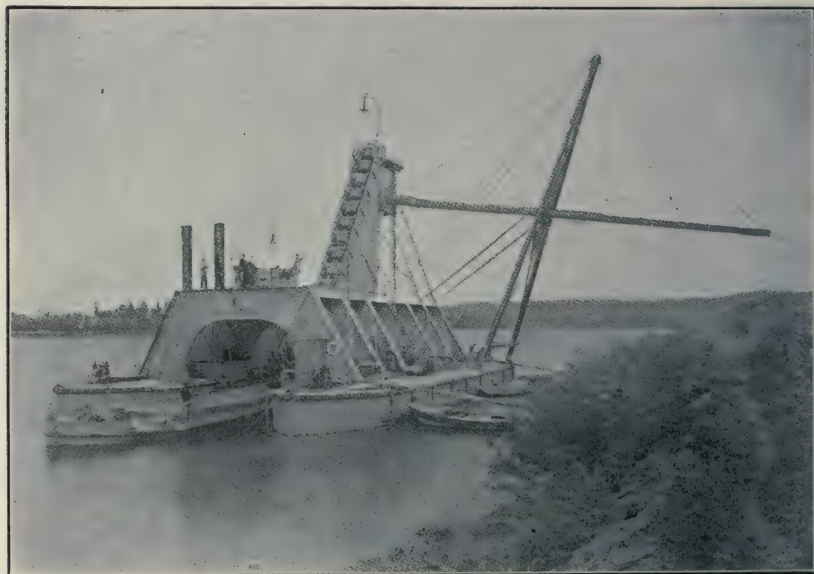

FIG. 69.—Floating Elevator for Unloading Barges.

charging into a long chute which delivers the materials to the land to be filled. The long chute can be supported in the manner indicated in the figure, or when the elevator is located too far from shore the chute can be supported by means of another float and in the manner already described on page 186. The ladder may contain only one series of buckets, like any ladder dredge, but owing to the fact that the buckets used are of small capacity, to hasten the unloading operation and at the same time to prevent increasing the size of the buckets, thus producing too much strain on the bottom of the scows, two series of buckets are usually mounted on

the same ladder. Fig. 69 represents a floating elevator with single bucket as built by H. Satre & Co. while Fig. 70 represents a floating elevator with double buckets used in the North Baltic Sea Canal and built by A. F. Smulders of Rotterdam. It is obvious that in connection with the bucket elevators only two types of barges can be used, and these are the open-hold barges and the deck barges with cargo boxes.

Other machines for elevating the débris from the barges are derricks or cranes. These are so extensively used on public works

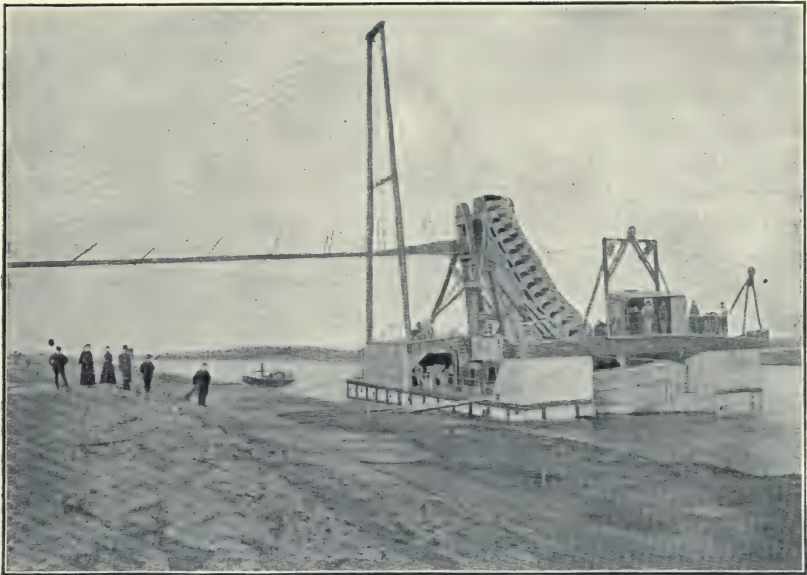

FIG. 70.—Floating Elevator with Double Ladder.

and so well known that a description is not necessary. They can be mounted, either on a fixed scaffold erected along the shores of the river or canal, or on a float. The scow with the dredged materials is placed alongside or under the derrick; the skips deposited on deck are attached to the hoisting chain of the derrick, lifted and swung to the land. The skips are dumped either directly into the cars, or into bins from which the material is loaded into cars when required. As previously stated, this method of transporting and lifting the materials is very seldom used.

Another method used for unloading scows is by means of a grab bucket dredge. In this case the débris from the scow is picked up by the bucket, which can be of the clamshell or orange peel type, and dumped either directly on land or into cars, running on tracks laid parallel to the shores. This method cannot be used, except when the difference of level between the water and the surrounding land is slight, and the materials must be raised only a short height.

When the dredged materials in the scows must be raised to a greater height, a grab bucket attached to a hoisting and conveying machine will be found more convenient. The apparatus in this case will consist of a solid scaffold firmly fixed on shore.

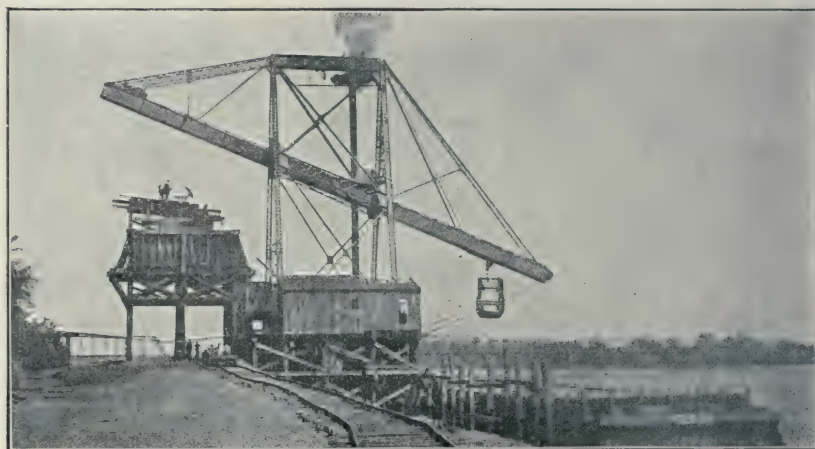

FIG. 71.—Grab Bucket for Unloading Barges.

On this scaffold is mounted an inclined cantilever beam with one end projecting well over the river so as to permit the bucket to be over the scow, while the other end extends over the land. The cantilever is inclined toward the river, thus leaving a large space for the bins on the land side. The grab bucket travels along the cantilever suspended to a small truck. The bucket is attached to the end of the hoisting cable and raised to the underside of the cantilever, when a hauling cable moves it along the whole length of the cantilever. The bucket of the usual capacity, varying between $\frac{1}{2}$ and 1 cu.yd., is opened and closed as explained for the grab dredges when the bucket is commanded by a double-chain system. The cantilever on the land side is of such height

as to permit the construction of bins for the temporary deposit of the dredged materials when removed from the scows. These bins are so constructed that railroad cars running on standard-gauge tracks may pass underneath them; thus the débris from the bins may be automatically dumped into the cars to be sent to their final destination. Fig. 71 represents one of these for unloading barges as used along the Mississippi River in connection with the sand and gravel industry. It was taken from Engineering Record, January 5, 1907.

CHAPTER XXIV

METHODS AND COSTS OF RIVER DREDGING

MUCH has been written in this treatise on dredges and their adaptability to various kinds of work. Space would not admit of a detailed description of all the classes of work, such as deep-sea dredging, harbors, drainage, land reclamation, mining and river work. However a description is given in this chapter of the improvement of the St. Lawrence River. This is one of the most important engineering works in America, and dredging has been carried on almost continuously for nearly 70 years. It serves too as an excellent example of dredging, as the conditions of the work and the kind of soils varies and several types of machines have been used. It will serve to bring out a number of important details regarding dredges and dredging. It is written from reports and information furnished by Mr. F. W. Cowie, chief engineer of the work.

The first improvement was started in 1844. The machinery first used was built in Glasgow, Scotland, but since then nearly all the dredges have been built in Canada. The progress made in the design and construction of dredges is aptly illustrated by the work done on this river. In 66 years the improvements to dredges have been phenomenal. For instance a dredge working in Lake St. Peter in 1846 excavated in one day about 1200 cu.yds. In 1888 a dredge working in the same place excavated 7200 cu.yds., while in 1906, 20,000 cu.yds. were frequently excavated in a day and night run.

The channel of the river from Montreal to Father Point, where the river flows into the Gulf of St. Lawrence, is about 340 statute miles. The greater part of the dredging is done between Montreal and Traverse, a distance of 220 miles. The work done from 1844-50 was in Lake St. Peter, to deepen some shallow places in order to allow 500-ton vessels to reach Montreal.

In 1851 organized work was undertaken to make a channel for large vessels from Montreal to Quebec, 160 miles. By 1888,

for a distance of 108 miles, from Montreal to Cap à la Roche, a depth of $27\frac{1}{2}$ ft. at low water had been obtained, while for the other 52 miles the river had been dredged to the same depth at half tide. Prior to 1888, namely from 1851-1888, 19,865,693 cu.yds. of material were dredged at a cost for labor and supplies of 17.1 cents., while the charge for plant, shops, repairs, surveys and other general expenses was 2.7 cents, making a total of 19.8 cts. The work from the start has been done with dredges and machines owned by the channel authorities and with day-labor forces.

For the period from 1889 to 1899 there was excavated 3,558,733 cu.yds., in widening and cleaning up the $27\frac{1}{2}$ -ft. channel, at a cost of 23.3 cts. for labor and supplies, to which must be added 14 cts. for plant, shops, repairs, surveys and other charges, making a total cost per cu.yd. of 37.3 cts.

Since 1899 work has been done on a new project, namely, a 30-ft. channel, from Montreal to the Traverse, the distance to be actually dredged being about 70 miles. Up to March 31, 1908, about $58\frac{1}{2}$ miles were finished, leaving at that time $11\frac{1}{2}$ miles to be dredged. The minimum width of this channel is 400 ft. in the straight portions, and from 500 to 750 ft. on the curves or turns. The entire channel has been widened, with the exception of a stretch in Lake St. Peter. Of a total of 68,500,000 cu.yds. of excavation to be made to complete this project 55,517,055 cu.yds. had been dredged up to March 31, 1908. The detail cost of this work will be given.

The materials excavated vary exceedingly. In Lake St. Peter soft blue clay mud is encountered; at other places, as where the fresh and salt water meets, sand-bars are found, of coarse sand; then stiff clay, hardpan, shale rock, large boulders and other materials are found at different localities.

A word about the St. Lawrence River. In many ways it differs from most rivers of the world, and this affects the work of dredging somewhat. An ordinary river generally has deep slopes and grades near its source, that mean great erosion of the bed and banks by the swift current. Thus near the source the water becomes saturated with soil, which is deposited in the level stretches of the river and at its mouth, always interfering with navigation. When such rivers are dredged, those portions fill up again with the fine sediment, thus making the work of dredging almost continuous, as in the Mississippi and Missouri Rivers. The only other

method of keeping this sediment out of the river is to narrow the stream and protect the banks by revetments in the flat parts of the river, as these prevent the stream from further eroding the banks, and the narrowed channel means a swifter current that will keep the sediment in suspension. Then at the mouth of the river jetties can be constructed that causes the current to sweep the channel clear and carry the sediment into the bay or ocean.

The source of the St. Lawrence River is in the Great Lakes, which act as huge storage reservoirs and settling basins. Except for floods caused by the melting and breaking up of the winter ice the fluctuations of the river are always gradual. Thus the material usually carried by river water is deposited in the settling basins, this being the case even with the few streams that flow into the St. Lawrence, as the so-called lakes and bays, as Lake St. Peter, act as settling basins for such streams. Generally, the bottom of the river is hard, and although in many places this makes difficult dredging, yet once dredged, the work is permanent. The currents of the river are regular, and although there is little danger to vessels that navigate the river, yet the water at times becomes rough from sudden squalls, compelling the dredges to suspend work and seek sheltered places. The season of dredging is about $7\frac{1}{2}$ months.

As the material dredged is dumped into the river at places where it will not interfere with navigation, it is seen that this work does not theoretically nor practically lower the level of the water.

The following plant was used on the river during the season of 1907:

- 6 elevator dredges.
- 1 hydraulic dredge with 23 double pontoons, floating a 2300-ft. double line of pipe, and 2 winch scows.
- 1 twin-screw self-containing hydraulic dredge.
- 1 twin-screw sea-going pump dredge.
- 1 ice-breaking and sweeping tug and 1 testing or sounding scow used with it.
- 1 inspection tug.
- 11 tugs for serving dredges.
- 4 coal barges.
- 1 coal scow.
- 2 stone lifters.
- 6 lodging scows.
- 14 hopper scows.

As the dredging is completed the channel is swept, so that the depths dredged are reliable and available. A twin-screw river steamer and a testing scow have been used as a sweeping plant, but now a new ice-breaking and sweeping tug has been designed for this purpose. In the Detroit River Improvement a drag, consisting of a bevel-shaped iron-shod beam loaded heavily with scrap iron and suspended from one end of a dump scow is used to sweep the bottom where earth has been removed. When dragging this contrivance over the dredged area, the cutting beam is usually set about one foot below the required depth. This tool is effective in soft material only.

One of the six elevator dredges was built in 1894, one in 1897, two in 1900, one in 1901 and one in 1902. These dredges are from 148 to 168 ft. long; have beams of 30 to 34 ft., and an average draft of from 8 to 11 ft., and a working depth from 42.5 to 45 ft. The buckets are of a capacity up to 1 cu.yd. and can excavate from 1000 to 3500 cu.yds. of fairly hard material per day. Two of them have steel hulls, the rest wooden ones. These dredges have all been built by the Canadian Government at their Sorel yards.

In consideration of the character of the shale rock, of the strong current, and of the fact that the work must be carried on without interrupting navigation the elevator dredge is well adapted for this work. A powerful dipper dredge may tear up a certain quantity of soft rock more quickly, without stopping to make a clean, even bottom. Chisel cutters and blasting plants may break up harder material, but taking everything into consideration this type of plant is particularly well designed for good, clean work, without interrupting navigation. Only the best machinery can stand up under the constant, steady work in the hard material encountered. This is evidenced by the fact that the buckets suffer much from each season's work. The dredge "La Fontaine," built in 1901, after three seasons' work had a complete new set of solid steel rock buckets put into her. The dredge "Baldwin" had her buckets rebuilt after two seasons' work. At the end of the season of 1907 the total cost of renewals and repair on buckets alone was \$71,826.12. This makes an average of about \$20,000 per dredge for new sets of buckets. The "Laurier," built in 1897, had a new set of $\frac{3}{4}$ -cu.yd. hardpan buckets put in her in 1906, at a cost of \$19,336.

The hydraulic dredge used is the well-known "J. Israel Tarte," designed by Mr. A. W. Robinson. This dredge was designed for

work in Lake St. Peter, and in a paper delivered before the Canadian Society of Civil Engineers Mr. Robinson states the following conditions were considered in her design and building:

"It must be able to make a cut 900 ft. wide at one time and 5 ft. to 10 ft. thick at one cut.

"It must leave a clean and level bottom and cut mechanically the entire area, as the material is blue clay and will not run or wash like sand.

"It must deliver the material sufficiently far to one side of the channel to avoid any risk of washing back again.

"The floating pipe line must be so arranged that it will freely permit of the movements of the dredge, and that it will withstand the wind and waves due to the locality, which are severe at times.

"The dredge must be so worked that it will not obstruct the channel for passing ships.

"The anchorage and movements of the dredge must be so arranged that the feed will be continuous and uniform.

"The capacity to be a working rate of 2000 cu.yds. per hour.

"The dredge must have ample coal supply, also provision for a double crew."

The contract price for this dredge was \$163,800, not including the discharge price or winches nor the alterations made. The dredge was built by the Pilsom Iron Works of Toronto, Ont., in 1901 and tested that year, but was not put to work until June, 1902. Previous to this dredging had been done in Lake St. Peter by elevator dredges.

During the season of 1886 one such dredge excavated 886,710 cu.yds. for \$25,723, or a cost for labor, coal, etc., of 2.9 cts. The dredge "Lady Aberdeen," with 1 cu.yd. buckets during the season of 1901, excavated in 21 days at a cost of \$3054.88, 120,600 cu.yds., the unit cost being 2.53 cts. The actual working time was 246 hours, thus an hourly output of 490 cu.yds. was attained.

The first month, June, 1902, the "J. Israel Tarte" was put to work; she excavated 93,750 cu.yds. This was accomplished in 41½ hours. Each month the output increased as the crew became accustomed to the work. Thus in September 580,000 cu.yds. were dredged, in October 600,000 cu.yds. The area covered in September was 7800 lin ft. by 325 ft., to an average depth of 5 ft. In October a strip of the same width and depth but 8000 ft. long was done. The dredge worked 126 working days in the season of 1903,

excavating 2,671,750 cu.yds., scow measurement, giving a daily rate of 21,200 cu.yds. During the month of September, 1903, the dredge excavated 757,100 in 25 days or 552 hours, making an average rate of 1646 cu.yds. per hour, or 30,280 cu.yds. per day. During the season of 1904 in 92 days the "Tarte" dredged 1,123,125 cu.yds. at a total cost of \$79,302.02, or 7.06 cts. per cu.yd. In 1905, 1,984,510 cu.yds. were moved, costing \$117,668.03, or 5.92 cts. per cu.yd. This work was done in 160 days. For the season of 1906, in 105 working days 1,358,560 cu.yds. were excavated, costing \$86,533.82 or 6.36 cts. per cu.yd.

The "J. Israel Tarte" is 160 ft. in length, 42 ft. beam, with a draft of 6 ft. (see Fig. 34). The suction frame is 80 ft. long, giving a possible working depth of 45 ft. The discharge pipe is 36 in. in diameter. The four boilers are of the marine type, carrying 160 lbs. pressure. The rotary cutter is 9 ft. long and 9 ft. 6 in. in diameter. There are four steel blades at the apex and 8 at the throat (see Fig. 27). The blades are designed so that the clay does not clog up the throat. The cutter is operated by a pair of double tandem engines of 300 H.P. (see Fig. 26).

Near the close of the season of 1903 one of the boilers on this dredge exploded, killing two men and injuring the dredge. It took four months to make the repairs. Four new boilers were placed in her. These, with a new system of steam piping, erecting the smokestacks and work on her cabin cost \$27,644.11. At the end of 1905 a general overhauling was given the machinery and boilers. Thus the dredge, as it now stands, cost for hull, machinery, 5-ft. pipe line, as altered and improved, about \$400,000. The annual repairs have varied from \$8000 to 20,000, or a little more than 5 per cent of the cost of the machine.

The annual repairs to one of the ladder or elevating dredges used on the St. Lawrence, with its necessary outfit, averages about \$10,000. It cost about \$40,000 per year to operate such a dredge, and about twice that amount to operate a hydraulic dredge such as the "Tarte." It is estimated that the entire dredging plant used on the St. Lawrence River cost about \$2,000,000. This is exclusive of a well-equipped shop maintained by the Canadian Government at Sorel for building and repairing dredges, tugs, scows and other things needed both on the St. Lawrence and for other dredging work.

In 1906 a hydraulic hopper dredge was purchased and put to

work in the channel below Quebec. This machine, the "Galveston," is 233 ft. long, 39 ft. beam, and of 14 ft. 9 in. draft when loaded with 1800 tons. The hopper capacity is 1400 cu.yds. The machine dredges to a depth of 55 ft. and can pump 1350 cu.yds. in 45 minutes. The price paid for this dredge, built in 1904, was \$146,000. It was brought from New Orleans to Quebec in 29 days, the expenses of the trip for docking, repairing, wages, provisions, stores, etc., amounting to \$10,942.14. This, exclusive of \$4,574.17 insurance. Another dredge of this type, the "Beaujeu," the largest dredge in Canada, has also been added to the fleet.

About 500 men are employed on this work. These men have been born and bred as sailors, and are from Sorel or some of the parishes bordering on the St. Lawrence River. The majority have been in the service since boyhood. The senior captain of the fleet makes the statement, with a great deal of pride, that he has never earned a cent in any other service. The careful training of the men has added much to the success of the work, as great care and patience are needed as well as continual watching, made necessary by the passing vessels.

A captain is in charge of the vessel and an engineer of the machinery. The rest of the crew is divided into two watches, working in 6-hour shifts, each watch working two shifts per 24-hour day. Each week 132 hours are worked from midnight Sunday until noon Saturday, only two holidays being observed: Dominion Day and Labor Day. The captain boards the men by contract. Most of the dredges and tugs are fitted up with quarters for the men, but in addition to this there are six scows with lodging accommodations on them.

The following is a list of the crew and the wages paid to them on the ladder dredges:

1 captain.....	\$80 per month
1 engineer.....	90 "
4 officers.....	\$40 to 65 "
2 engineers.....	40 to 60 "
10 sailors.....	28 "
6 firemen.....	30 "
1 watchman.....	28 "
3 women cooks.....	12 to 18 "

The crew and their salaries for work on a hydraulic dredge are as follows:

1 captain.....	\$100 per month
1 engineer.....	105 "
4 officers.....	50 to 75 "
2 engineers.....	55 to 70 "
2 scowmen and carpenters.....	50 "
12 sailors.....	28 "
6 firemen.....	32 "
2 greasers.....	40 "
1 watchman.....	28 "
4 women cooks.....	12 to 18 "

The men are not charged for their board, which would no doubt mean an increase of about \$12 per man per month. The crews of the tugs are paid similar salaries. Large crews are necessary to handle with safety the loaded scows. During the closed season, for 4½ months, only enough engineers and firemen are retained to look after the vessels. In considering the cost of this work one must keep in mind that the wages paid are small and the hours worked long. If this same work was being done for the United States Government either by contract or day labor three shifts would have to be worked, adding from 10 to 15 men to the crews and higher wages would have to be paid. The records, though, are of value, as they extend over a long period of time, and costs are given as to repairs and maintenance and other details that are generally difficult to obtain.

The method of operation is of interest. The river is divided into five divisions so as to organize the work for supervision and for the greatest efficiency. The "Galveston" is worked continually below Quebec and the "Tarte" in Lake St. Peter, but the other dredges are moved from division to division according to the class of material to be excavated or to the urgency of the work. The dredges stop only for repairs, for moving from place to place, for bad weather or to allow vessels to pass. In only a few cases are records given of these delays. Coal is supplied by barges without stopping the work. Much would be added to the cost data given if detail records of delays could be shown.

The elevator or ladder dredges load scows, one tug with two scows and a spare scow serving each dredge. The average distance the excavated material is hauled is less than one mile. The scows hold 300 cu.yds., and as it takes a tug 15 minutes to haul one of these away, dump it and return, it is possible with this service to take away 1200 cu.yds. per hour, more material than a dredge is likely to excavate. These dredges are held to their work by a long

bow cable and two cables on each side of the vessel, see Fig. 71. This permits a vessel to make a wide radial cut and to easily clear passing boats.

The "Tarte" is held in the same manner, which allows it to work from one side of the channel to the other. To allow vessels to pass, one set of side lines are slackened so that they drop on the river bottom and the passing boats go over them. The pipe line, which is about half a mile long, has ball and socket spring joints between every pontoon. These pontoons are made of two cylindrical air chambers, holding 100 ft. of discharge pipe between them. The discharge end of the pipe is held in place by a winch scow. When the dredge works on the side of the channel on which the discharge is made, the pipe assumes, by floating on the pontoons, a decided curve, but as the dredge passes to the other side of the channel the pipe line straightens out, the operation only varying the discharge end slightly, see Fig. 36.

Both style of dredges work to a uniform bottom, cleaning up as they go. When boulders are encountered the stone lifters are used. In one case, when the cutter head of the "Tarte" broke off, it was recovered with one of these boats. In addition to the sweeping of the channel after dredging, the shallow channels are swept once a year.

Cost Data. In giving the following tables of costs, everything is included except interest on the capital and depreciation. The tables are self explanatory. The item of repairs includes keeping the plant in good order, but not new or improved machinery.

TABLE I

Year.	Number of Cubic Yards (Scow Measure).	Wages, Supplies, etc.	New Plant Rebuilding Shop Surveys, etc.	Cost per Cubic Yard, Wages, Supplies, etc.
1899-1900	1,107,894	\$100,191.01	\$265,270.78	\$0.090
1900-1901	2,479,385	136,680.83	287,049.04	0.055
1901-1902	3,098,350	185,429.80	479,731.47	0.060
1902-1903	6,544,605	255,766.55	277,703.50	0.040
1903-1904	4,619,260	276,958.59	308,765.44	0.060
1904-1905	2,716,220	311,087.93	266,460.33	0.115
1905-1906	4,047,530	431,738.30	125,107.37	0.106
1906-1907	3,001,010	302,677.37	80,613.26	0.102

Table I, gives for a term of eight years, material excavated, and total cost for wages, supplies, new plant surveys and other details.

TABLE II

Season.	Material.	Number Cubic Yards.	Total Cost.	Cost, Cubic Yards, Cents.	Number Days Worked.	Percentage of Actual Work.
Dredge No. 1, LAVAL:						
1904-5.....	Clay and boulders.....	215,925	\$39,027.20	18.07	173	63
1905-6.....	Clay and stones.....	144,000	50,828.47	35.29	185	62
1906-7.....	Clay and stones.....	161,550	38,596.98	23.89	121	63
Dredge No. 2, LAURIER:						
1904-5.....	Clay and boulders.....	149,750	41,271.36	27.56	165	52
1905-6.....	Clay and sand.....	408,350	49,255.65	12.06	185	63
1907-8.....	Clay and stones.....	130,300	32,199.71	24.71	121	60
Dredge No. 3, LADY ABERDEEN:						
1904-5.....	Hardpan.....	295,400	39,163.00	13.25	181	64
1905-6.....	Hardpan boulders.....	270,700	46,886.99	17.32	180	70
1906-7.....	Clay, sand, stones.....	256,900	32,059.41	12.47	124	67
Dredge No. 4, LADY MINTO:						
1904-5.....	Hardpan.....	56,000	25,409.25	45.21	59	65
1905-6.....	Clay and boulders.....	278,650	50,739.82	18.20	184	66
1906-7.....	Clay and boulders.....	412,400	33,463.27	8.11	121	75
Dredge No. 5, LAFONTAINE:						
1904-5.....	Hardpan boulders.....	574,000	44,237.71	7.70	181	61
1905-6.....	Hardpan boulders.....	213,600	55,763.39	26.09	185	71
1906-7.....	Hardpan, clay shale.....	161,400	42,159.23	26.12	121	67
Dredge No. 6, BALDWIN:						
1904-5.....	Hardpan boulders.....	301,820	42,677.59	14.14	172	67
1905-6.....	Clay.....	747,720	55,640.95	7.44	186	74
1906-7.....	Clay and stones.....	519,900	42,159.23	7.24	127	67
Dredge No. 7, J. ISRAEL TARTE:						
1904-5.....	Soft mud.....	1,123,125	79,302.02	7.06	92	67
1905-6.....	Soft mud.....	1,984,510	117,668.03	5.92	160	56
1906-7.....	Soft mud.....	1,358,560	86,533.82	6.36	105	54

TABLE III—ITEMIZED COST OF WORKING EACH DREDGE, SEASON OF 1904-5

Dredges.	Fuel.	Wages.	Board.	Stores and Material.	Repairs and Labor.	Proportion, General and Office Expenses.	Proportion, Stone-lifter Service.	Tug Service.	Proportion, Inspection, Towing, Sweeping.
(1) Laval.....	\$6,826.68	\$6,619.60	\$2,576.34	\$1,198.77	\$4,752.56	\$1,927.00	\$805.08	\$8,987.12	\$5,334.05
(2) Laurier.....	4,818.69	6,599.30	2,349.22	1,211.93	7,330.01	2,300.00	805.09	10,523.07	5,334.05
(3) Lady Aberdeen..	6,023.88	6,928.41	2,612.74	1,408.22	4,204.59	2,018.00	805.08	9,828.03	5,334.04
(4) Lady Minto.....	2,268.14	2,527.87	802.15	1,273.72	6,055.62	1,932.00	805.08	4,410.43	5,334.04
(5) Lafontaine.....	6,862.70	6,883.49	2,671.07	1,502.04	6,303.15	2,294.00	805.09	11,618.12	5,334.04
(6) Baldwin.....	6,691.94	6,703.95	2,608.77	757.49	9,956.00	2,189.00	805.09	7,631.30	5,334.05
(7) J. Israel Tarte..	18,026.59	19,799.14	3,337.80	2,207.02	4,437.23	3,808.00	17,018.16	10,668.08

TABLE IV—ITEMIZED COST OF WORKING EACH DREDGE, SEASON 1905-6

(1) Laval.....	\$7,192.94	\$7,254.12	\$2,570.62	\$1,791.19	\$11,670.10	\$5,272.78	\$640.39	\$8,008.35	\$6,427.98
(2) Laurier.....	6,271.74	7,097.96	2,575.38	2,223.06	9,248.50	4,712.08	640.39	10,038.56	6,427.99
(3) Lady Aberdeen..	6,974.38	5,942.18	2,507.83	2,150.56	8,096.56	4,391.28	640.39	9,755.83	6,427.98
(4) Lady Minto.....	5,985.04	7,084.09	2,542.98	2,388.97	11,666.02	5,125.71	640.38	8,878.65	6,427.98
(5) Lafontaine.....	8,256.82	6,109.65	2,586.54	2,174.85	11,675.55	5,334.54	640.38	12,530.06	6,427.99
(6) Baldwin.....	7,235.24	7,124.08	2,534.09	2,012.25	12,400.19	5,430.57	640.38	11,816.17	6,427.98
(7) J. Israel Tarte..	30,124.05	13,486.94	4,209.93	10,699.73	16,041.76	12,873.55	17,376.09	12,855.98

TABLE V—ITEMIZED COST OF WORKING EACH DREDGE, SEASON 1906-7

(1) Laval.....	\$4,398.80	\$5,050.30	\$1,804.54	\$ 506.70	\$10,356.16	\$4,203.97	\$365.20	\$6,795.20	\$4,716.12
(2) Laurier.....	3,632.55	4,977.68	1,742.01	1,455.64	4,735.48	3,089.23	365.19	7,458.81	4,716.12
(3) Lady Aberdeen..	4,053.80	5,084.43	1,850.58	662.10	5,846.78	3,267.78	365.20	6,212.62	4,716.12
(4) Lady Minto.....	3,914.05	4,862.22	1,751.79	1,123.91	6,137.92	3,321.25	365.19	7,270.82	4,716.12
(5) Lafontaine.....	4,964.56	4,837.01	1,810.57	2,061.15	10,364.95	4,489.38	365.20	8,550.29	4,716.12
(6) Baldwin.....	4,810.06	4,953.83	1,809.53	676.35	7,761.46	3,737.30	365.20	8,835.10	4,716.12
(7) J. Israel Tarte..	25,429.48	9,522.72	3,125.70	3,174.12	13,512.90	10,226.29	12,110.37	9,432.24

TABLE VI—ITEMIZED COST PER CUBIC YARD FOR EACH DREDGE FOR THREE SEASONS.
(A wide variation is shown in total unit cost)

Season and Dredges.	Fuel.	Wages.	Board.	Stores and Materials.	Repairs and Labor.	Proportion, General Office Expenses.	Stone-lifter Service.	Tug Service.	Inspection, Towing, Sweeping.	Total.
(1) Laval:										
1904-5.....	\$0.031	\$0.030	\$0.012	\$0.006	\$0.022	\$0.009	\$0.004	\$0.042	\$0.025	\$0.181
1905-6.....	0.050	0.050	0.018	0.013	0.080	0.037	0.005	0.005	0.055	0.353
1906-7.....	0.027	0.031	0.011	0.005	0.064	0.027	0.002	0.042	0.030	0.239
(2) Laurie:										
1904-5.....	0.032	0.043	0.015	0.009	0.049	0.015	0.005	0.070	0.038	0.276
1905-6.....	0.015	0.018	0.005	0.005	0.022	0.012	0.012	0.025	0.015	0.120
1906-7.....	0.028	0.038	0.013	0.011	0.036	0.024	0.003	0.058	0.036	0.247
(3) Lady Aberdeen:										
1904-5.....	0.020	0.024	0.009	0.005	0.014	0.007	0.003	0.033	0.018	0.133
1905-6.....	0.925	0.022	0.010	0.008	0.029	0.016	0.002	0.036	0.025	0.173
1906-7.....	0.016	0.021	0.007	0.002	0.023	0.012	0.001	0.024	0.018	0.124
(4) Lady Minto:										
1904-5.....	0.040	0.045	0.014	0.022	0.108	0.034	0.014	0.080	0.095	0.452
1905-6.....	0.021	0.026	0.009	0.008	0.042	0.029	0.003	0.031	0.023	0.182
1906-7.....	0.010	0.012	0.004	0.003	0.015	0.008	0.001	0.017	0.011	0.081
(5) LaFontaine:										
1904-5.....	0.012	0.012	0.005	0.001	0.018	0.004	0.001	0.014	0.010	0.077
1905-6.....	0.039	0.029	0.012	0.010	0.054	0.024	0.003	0.060	0.030	0.261
1906-7.....	0.031	0.030	0.010	0.013	0.064	0.028	0.002	0.053	0.030	0.261
(6) Baldwin:										
1904-5.....	0.022	0.022	0.009	0.003	0.033	0.007	0.003	0.025	0.017	0.141
1905-6.....	0.009	0.009	0.003	0.003	0.017	0.007	0.001	0.016	0.009	0.074
1906-7.....	0.009	0.010	0.003	0.001	0.015	0.007	0.001	0.017	0.009	0.072
(7) J. Israel Tarte:										
1904-5.....	0.016	0.017	0.003	0.002	0.004	0.003	0.015	0.100	0.070
1905-6.....	0.015	0.006	0.002	0.005	0.008	0.007	0.009	0.007	0.059
1906-7.....	0.019	0.007	0.002	0.002	0.010	0.008	0.009	0.007	0.064

Table II, gives the work done by each of seven dredges for three seasons. Class of material excavated, total cost, cost per cu.yd., number of days worked, and percentage of actual time work. Time lost by repairs, moving, bad weather, clearing traffic and other delays, amounting to more than one-third of total time worked.

CHAPTER XXV

DREDGING FOR METALS

DREDGES are used for mining precious metals, especially gold, tin, diamonds and platinum. At first dredges were used only when metals were recovered from the bottoms of rivers, but it was found that by excavating a small pond or lagoon and placing a dredge in it, alluvial deposits could be mined at a low cost by dredges. This is now done in many parts of the world.

Tin Dredging. For tin dredging, hydraulic dredges are used. Much of this class of mining is done in Australia and New Zealand. Elevator or ladder dredges can be used, and when gold and tin are dredged together they are sometimes used, but with difficulty, as the specific gravity of the two metals varies much. One authority states that the ladder dredge for stream tin is efficient, but he has little faith in it when there is much overburden.

Platinum Dredging. Dredging for platinum is done in the Urals in Russia and also in Siberia. Ladder or elevator dredges have been used for some years. Those first used were machines bought second hand that had been engaged in excavating the Kiel Canal. These dredges made some money, especially when the price of platinum was high, owing to the cheap labor that could be obtained, but as they were not built for mining purposes they were poorly suited to the work. Other dredges of the ladder type, designed for the purpose, have been built and are operated much cheaper. The dredges are used to excavate the overburden and also the gravel containing the platinum. For this purpose two dredges are sometimes used together. The overburden being deep, two or three times as much material must be handled by the dredge as when working the gravel. Accordingly a large capacity dredge is used for the overburden and a small one for the gravel. In this way the two classes of work are done simultaneously. During the year 1908, 64 dredges were worked in this business.

Diamond Dredging. Ladder dredges are also used for diamond mining. The dredges save diamonds on its screens and jigs, which

are located at the stern. The dredges are of the close bucket type, and there is said to be a great chance for improvement on the diamond-saving end. Such dredging is now being done in several parts of the world.

Gold Dredging. Dredging is done more extensively for gold than for any other metal or precious stone, and much has been written on the subject. It is impossible to fully cover the subject here.

Numerous kinds of dredges have been used and are being used for gold dredging, among them being the suction and hydraulic power dredge, the dipper, ladder and the submerged jet dredge.

It is claimed that the hydraulic suction dredge is not efficient, as the grains of gold, on account of their great weight, drop to the bottom, even when rotary cutters are used on the suction pipe. However, they are used in some sections and in some soils with fairly good results. For instance when the grains of gold are exceedingly small and found entirely in coarse-grained sand the suction dredge has cleaned up the gold. Also when the gold-bearing gravel or sand is underlaid with fissured rock, so that much of the gold cannot be reached with buckets, the suction dredge has cleaned up such bottoms. Mr. Henry G. Granger advocates the use of a hydraulic suction dredge for gold mining, and in a paper before the Am. Inst. of Mining Engineers gives the specifications for such a dredge with a capacity of 1000 cu.yds. per hour, capable of raising large boulders. One consideration against hydraulic suction dredges is the supply of water and the power needed. In bucket dredging, under favorable conditions, about one-eighth part of water to one part of material is lifted, while in centrifugal pump elevating, at least fifteen parts of water to one of material have to be raised, this being necessary, according to Mr. H. L. Lewis, as the water has to be applied for treatment of the gravel in addition to keeping everything in a state of solution for successful elevation. It is evident that this means more power, and shows the necessity of a large amount of water.

The dipper and grapple dredges have been used for gold, but they are illy adapted to the work, as they disturb the gravel in digging so that much of the gold sinks to the bottom and is lost. It is also impossible to construct a bucket that is watertight, consequently the gold collected at the bottom of the bucket is readily lost through the cracks. Likewise as they are intermittent machines they deposit

too much material at one time, and there is a long interval between the loads.

The hydraulic power dredge is used for gold dredging in New Zealand. It is known as the O'Brien Patent Hydraulic Power Dredge. Water is supplied at sufficient elevation to give gravitation pressure to a Pelton wheel for operating a ladder dredge. Thus this power is used instead of steam or electricity. This motive power saves in the first cost of construction in boilers and engine, fuel, engineers and maintenance expenses. When gravitation pressure can be obtained, this system can dredge and treat gravel at a much cheaper cost than steam power.

Another dredge used in gold mining in New Zealand and Australia is the Johnson Submerged Jet Dredge. The principle is that of the hydraulic elevator adapted to the requirements of a dredge, and consists of ordinary pontoons divested of boiler, engine and bucket ladder, these being replaced by a hydraulically-driven Pelton wheel to work winches, and a hydraulic elevator in place of a bucket ladder to raise materials. The pressure is from gravitation of water. The theoretical supply of the elevator is 1000 tons per hour.

In Chapter V is mentioned a dredge used for gold mining in California, from which a caisson is lowered to the river bed, and the water pumped from it. Then men enter this caisson and by hand excavate the sand and gravel containing the gold.

The DuBois hydraulic dredge is also used. In this dredge a caisson is dropped to the river bottom and the suction pipe is let down into the caisson. A diver going down on the outside of the caisson enters it, and stirs up the gravel, causing it to enter the suction pipe. It is stated that in this manner the fine particles of gold cannot float away. Under favorable conditions the diver can remain under water several hours.

Ladder Dredges. The ladder dredge, taking up the material from the bottom with a minimum of agitation and working slowly and steadily is to-day considered the best for gold dredging. Besides, the buckets retain fully their content, carry a quantity of water to facilitate the work of washing, and deliver the material amidships in a continuous small stream. For these reasons the ladder dredge has always been recognized as the ideal type of dredge for gold mining.

The ladder dredge employed in mining consists of three different parts, which are: (a) the ladder dredge for the excavation of the

materials from the bottom; (b) the apparatus for washing the débris and collecting the gold; (c) the conveyor for the disposal of the tailings. Each one of these will be described separately, but all are mounted on a single pontoon.

The pontoon of a placer dredge is designed to work in shallow water and consequently is built with a flat bottom in order to have the least draft. It is provided with a central well for the ladder and the walls of the pit are firmly held together by the truss of a gantry used for the raising and lowering of the ladder. The pontoon is generally built of wood, but when the dredge must be shipped to distant points or where skilled labor is scarce, the pontoon is made of steel plates and girders built up in sections of such weight as to be easily transported and joined together. About the center of the pontoon is located the tower supporting the upper end of the ladder.

The ladder is built up of steel beams and plates riveted together and forming a solid support for the loaded buckets that slide on its upper surface. To facilitate the sliding several rollers are introduced. The lower end of the ladder carries the tumbler of polygonal shape, around which revolve the buckets, while as usual the driving tumbler is at the upper end of the ladder. Ladders are made of different lengths, varying with the depth at which the dredge is designed to work. In any case it is preferable to have the ladder of such length as to work under an angle of 45° . Buckets are made from 3 to 13 cu.ft. capacity. The Bucyrus Co. build placer dredges of three sizes, having buckets of 3, 5, and $7\frac{1}{2}$ cu.ft. capacity respectively. Buckets are constructed of steel plates reinforced at the mouth by another steel plate of greater thickness; they are built with wide mouth in order that their contents may fall more rapidly when the point of discharge is reached. In some dredges the buckets are attached one to another so as to form a continuous series succeeding each other on the consecutive faces of the revolving tumbler. In other dredges the buckets are alternated with the links of the chain so that a bucket and a link succeed each other upon the consecutive faces of the tumbler. The links are made of solid steel bars connected by steel pins. The bucket chain moves along the ladder owing to the revolving of the driving tumbler being driven by special engines and the power transmitted in any one of the ways indicated in the general discussion of the ladder dredge. The engine for lifting the ladder and other

machinery is also similar to those employed in the ladder dredges of equal capacity.

The appliances used for the treatment of the dredged materials can be divided into two classes, namely, the screen and elevator and the sluice-box. The former is provided with a screen through which the material raised is washed onto tables and discharged astern of the dredge in a semicircular chute. The coarser material passes out of the screen into a tail chute also to be deposited astern, either by passing over a sluice run or being conveyed in the trays of a tailings elevator. The sluice-box dredge is the one in which the gold is caught in a long sluice run, fitted with ripples, into which the buckets tip their burden.

In the screen type of dredge the buckets discharge the material into a hopper, through which it passes into either a revolving or shaking screen of sufficient size and length to enable it thoroughly to screen and wash the most difficult material. The revolving screen is usually made 16 or 17 ft. long and 54 in. in diameter and built with a frame of steel rings and perforated steel plates so arranged that they can be easily renewed when worn out without removing the entire screen. The screen is mounted on adjustable steel rollers on a pitch of 1 in. to the foot and is driven by special shafts and gears connected with the main engine. Streams of water are introduced into the upper end of the screen to wash the material as soon as it enters; water is supplied by a centrifugal pump operated by a special engine. In the screen all the fine materials being washed will fall through the holes while the stones and the coarse materials will pass out of the lower end and be deposited on the banks by means of an elevator or other device. The gold, together with the materials and water falling beneath the screen, are collected in a specially constructed box which will equally distribute the materials upon the gold-saving tables. These can be made of different designs, but as a rule are constructed of steel plates and angles. They can be built 14 ft. long and 12 ft. wide, made in four widths of 3 ft. each stepped one above another with division plates between them. The tables have an inclination of 1 in 10 and are covered with some fibrous substance held down by strips of expanded metal acting as ripples. Besides the water from the screen, which is conveyed onto the gold-saving tables, together with the materials, to facilitate the washing operations additional water is supplied by a special pipe whose flow on each division is regulated by a sliding door.

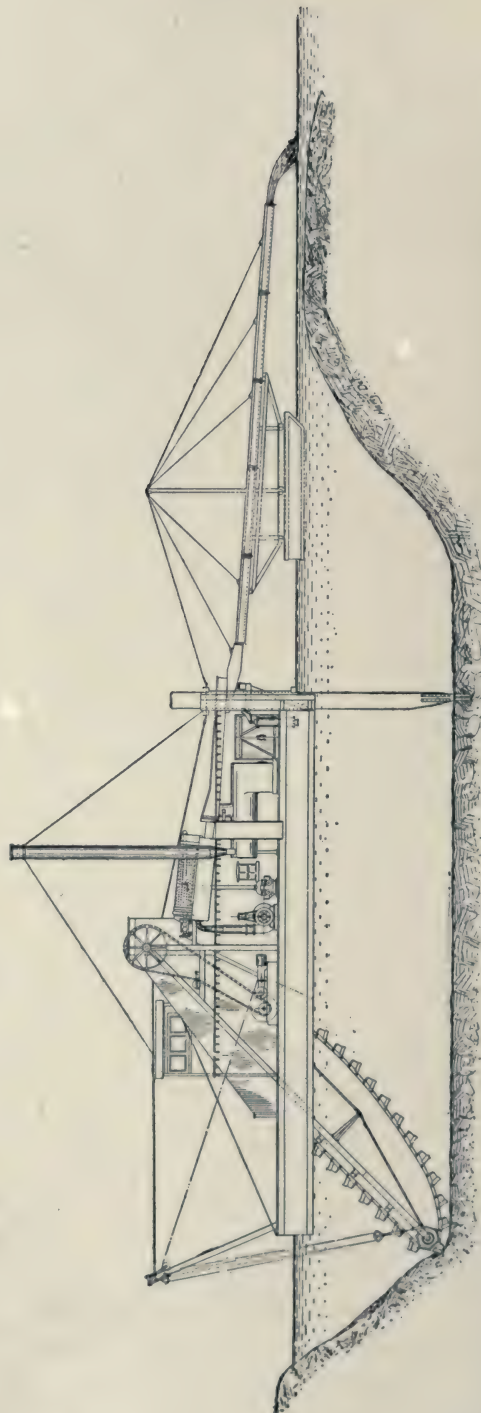
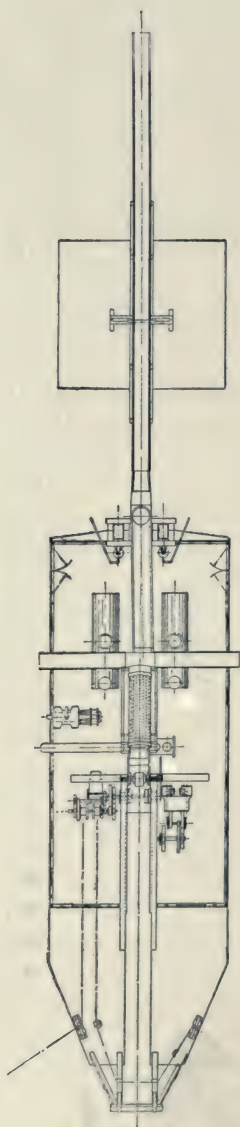

Fig. 72.—A Placer Dredge with Revolving Screen.

The tables empty into a chute of semicircular cross-section running out over the stern of the dredge. The gold that has not passed through the screen perforation onto the gold-saving tables is collected in the sluice-box. This can be made 24 ft. long, 3 ft. wide and 18 in. deep, fitted with ripples placed above mattings made of some fibrous matter and discharging into the semicircular chute.

The stones, gravel and other materials, after having been thoroughly washed out in the revolving screen, come out from its lower end and by means of a conveyor are deposited at sufficient distance and height for stacking purposes. Fig. 72 shows the side view and plan of a placer dredge with revolving screen as built by the Bucyrus Company of South Milwaukee, Wis.

When the material is finely divided, instead of a revolving screen shaking screens are employed. As in the dredge previously described, the material is delivered into a hopper, through which it is conveyed to shaking screens of sufficient size to handle the largest stones that can be brought up in the buckets, and of sufficient length to thoroughly screen and wash the material from a series of openings above. Small streams of water are projected upon all parts of the screen, washing and disintegrating the material before the finer particles pass through to the gold-saving tables. The coarser material is discharged at the lower end of the screen into a hopper leading to a belt conveyor or tailings-stacker. The fine material passes through the screens into a distributor, placed beneath the screens and above the gold-saving tables. The object of this is to distribute the material evenly over the tables. These tables are fitted with ripples, or such other devices as may be best adapted to the character of the gold. The material which passes over the tables is carried into sluice-boxes which lead aft to a point about 20 ft. beyond the stern of the dredge. These sluice-boxes are also fitted with ripples. Fig. 73 shows the plan and elevation of the placer dredge with shaking screen built by the Bucyrus Company of South Milwaukee, Wis.

When the gravel or the gold-bearing material is very fine the treatment by the sluice-box method is employed. Then the dredged material in tipping over the upper tumbler of the ladder goes through a drop plate, discharging into a long sluice which runs aft for the length of the dredge and over the stern. The length of the box will depend on the position of the tumbler framing, and the height to which the material is to be stacked. As a general

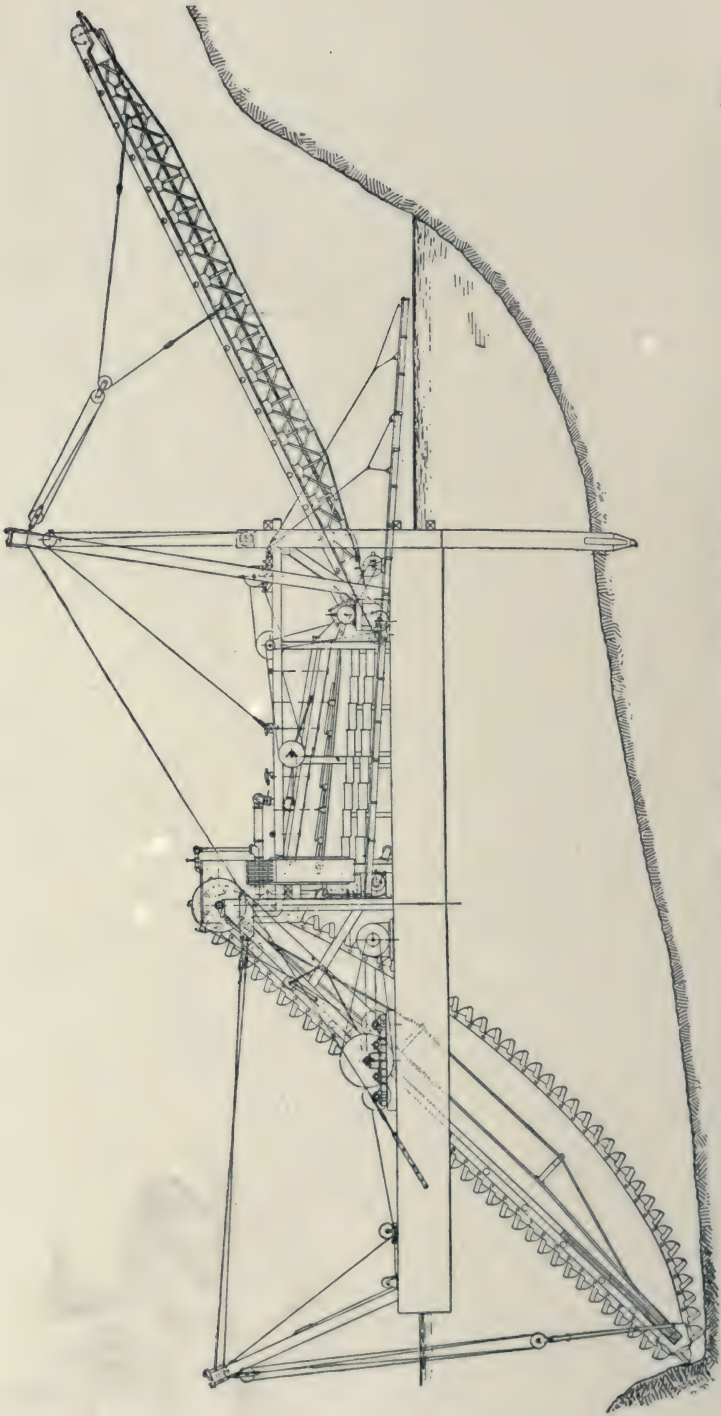

Fig. 73.—Placer Dredge with Shaking Screens.

rule the box is from 40 to 50 ft. long and varies in width from 3 to 6 ft., according to the class of materials to be treated. The pitch depends on the same thing and is from 1 in 8 to 1 in 10. Fig. 74 shows a sluice-box as given in a paper by Messrs. E. S. and G. N. Marks, reproduced in *Engineering News*, from which this description is condensed. The bottom of the box is laid with perforated plates and ripples for its entire length, the ripples overlying the fibrous matter. It was found convenient to use as many different classes of ripples as possible so as to alter the flowing of water and consequently the material being treated is tossed about, and the gold

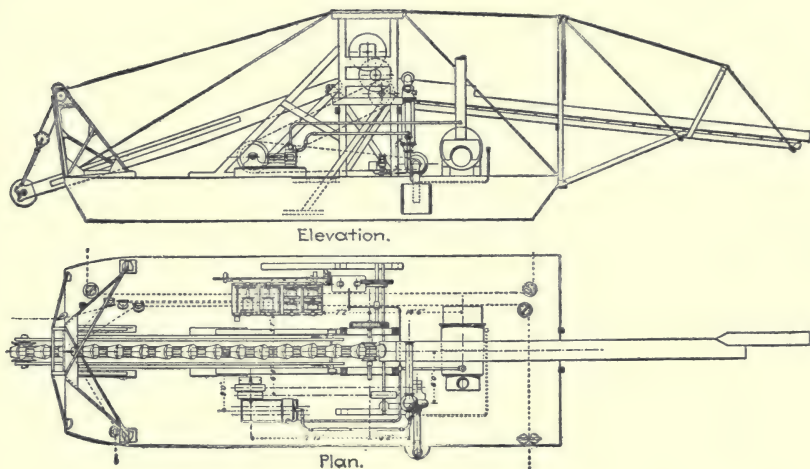

FIG. 74.—Placer Dredge with Sluice-box.

which may be adhering to the stones has more chance of being liberated. The classes of ripples used are angle iron, venetians, perforated plates and crimped or diamond-shaped. A return box is sometimes used fitted as indicated in the figure. An opening is made at the bottom of the box over which a perforated plate is placed and all the material that passes under the plate goes out by the return box behind the tail of the sluice run. The return box serves two purposes: it either saves any light gold that has traveled down the sluice-box or else it may be used to prevent a portion of the water from falling on the tailings. Plan and elevation of a ladder dredge with long sluice-box as used in Australia is given in Fig. 75, reproduced from the paper of Messrs. Marks.

The stones, gravel and in general the residual materials left after being washed out in the screens are expelled from the dredge and deposited in places where they will not interfere any more with the dredging operations. For this purpose different appliances are used. Thus for instance in the type of dredge with revolving screen illustrated in Fig. 74 the materials coming out from the lower end of the revolving screen enter into a chute, which is high enough and sufficiently inclined to discharge them clear of the sides of the boat. This method is convenient when dredging is made by scraping the soil on parallel lines and depositing the washed materials always on the same side of the dredge and above

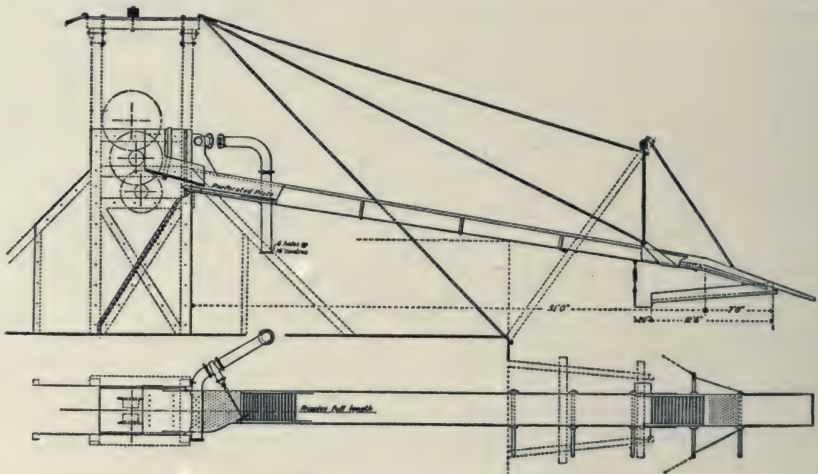

FIG. 75.—Plan and Elevation of a Long Sluice-box.

the ground already treated. But the most common method of disposing of the washed materials is by means of the elevator or tailing stacker as indicated in the Fig. 75. This consists of an inclined steel trussed beam with its lower end hinged to the stern of the pontoon while its upper end is supported by a gantry. Ropes and pulleys allow the adjusting of this beam to such heights as are required for the stacking of the materials. The upper side of the beam is provided with roller supporting the endless rubber belt, thus forming a proper belt conveyor of the usual type, the belt being moved along by the driving drum located at the lower end of the beam and geared to a special engine. The materials from the screens are conveyed through a chute made of steel plates, over

the belt, along which they travel and are tipped over when the belt revolves around the guiding drum at the upper end of the beam. Provisions are made to prevent the tipping of the materials on the sides at the beam. The beam is made 50 or 60 ft. long, thus allowing the dumping of the material at some distance from the back of the dredge.

These ladder dredges may be operated either by steam engines or by electric motors. Where two or more dredges are in close proximity to each other it is more economical to locate a power station on shore and transmit electricity to the dredges than to have engines or boilers on board.

These dredges as a rule do not work in rivers, but in trenches contiguous thereto. In most cases a pit is dug deep enough for the dredge to float in and of sufficient dimensions to allow it to turn round. Very little water is required to float the dredge and to operate it, as the water which is pumped for washing purposes comes back to the pit. The amount of water is determined by seepage and the cleanness of the gravel dug. The face of the pit must be kept square and its corners worked up, otherwise it will gradually narrow and ground will be left behind and lost. The dredge works ahead, undermining the banks, and the material will naturally fall to the buckets, when good work will result, and the dredge can then run for an hour or more with full buckets without being moved.

It is very important to keep the dredge running as near 24 hours a day as possible, for when a dredge stops, the producing part of the plant stops, while the expenses continue. Well-managed dredges are making a monthly average of from 80 to 90 per cent of the possible running time, including that lost for cleaning up of the gold tables, an operation which takes from 5 to 6 hours every fifteen days. This time, however, is not all dead loss, as it can be used to advantage in general repairs.

Of Australian dredges Messrs. Marks say: "The sluice-box or tables are cleaned up weekly, and the clean-up is conducted as follows: In either case the ripples or pieces of expanded metal are lifted and the lighter material caught in the sluice-box or tables, is run off the mats by a gentle stream of water, the gold, heavy sands, and pieces of metal of any description alone remaining. The mats being run clear, the water is turned off, and the calicoes (which are forming the upper stratum of the mattress of fibrous

matter) are lifted and washed one by one into a gold-box or tub until quite clean. When all the mats have been washed, they are relaid as before, preparatory to starting work.

The action of the buckets is slow but gradual. In the close-connected type the number per minute ranges from 18 to 30, while with link type 12 to 14 are delivered. The speed of the ladder is generally about 50 ft. per minute, varying with the hardness of the ground. Sometimes it is reduced to less than 40 ft., and again is increased to 75 ft. These dredges are now built to



FIG. 76.—Placer Dredge.

excavate to a depth of 65 ft. Fig. 76 illustrates this type of dredge.

The following description of the "Hunter Dredge" and of its work, and the cost of excavating gravel with it, is condensed from an article in *Engineering Contracting*:

"This dredge was built by the Western Engineering and Construction Co., of San Francisco, Cal., for the Oro Water, Light and Power Co., of Oroville, Cal. The dredging machinery proper was manufactured by the Bucyrus Co. of South Milwaukee, Wis. Operation of the dredge was commenced in August, 1907, working placer gravel 38 ft. deep from the water line to bed rock.

"The entire plant embodies the latest type of construction,

the hull being especially trussed along the well-hole line with an overhead structure. The bow gantry, supporting the digging ladder and buckets, is of the most improved design, being constructed to minimize working of the low pontoons.

"The buckets, each of 5 cu.ft. capacity, are close connected, and are provided with heavy manganese steel lips. Altogether there are 82 buckets.

"There are two winches on the boat, both located forward; one on the port side, by means of which the digging ladder is raised and lowered; the other on the starboard side, carrying the auxiliary lines used in swinging the dredge from side to side. The digging ladder is held up hard and fast to the face of the cut by means of a steel spud 24 by 36 in. and 50 ft. long. A wooden spud is also provided, of the same dimensions as the steel spud, and is chiefly used to move the dredge forward after the bed rock has been cleaned and a new cut is necessary. In this process, both spuds are alternately raised and lowered, until the dredge has stepped ahead to the position.

"This machine is operated entirely by electricity. Electric power is delivered at the dredge at approximately 4000 volts, being carried aboard by armored cable at that voltage and stepped down with transformers from 4000 volts to 400. The following motor equipment is used: The digging motor is a 100 H.P. type F, variable speed, operating, as all motors do, at 400 volts, and having a speed of 600 R.P.M. It is connected by belt to the port winch, which drives the bucket line, and lowers or raises the ladder.

"The motor connected with the starboard winch by a belt is of 20 H.P., type F, variable speed, having a speed of 900 R.P.M. By means of this motor and winch, the wooden and steel spuds are hoisted, the stacker raised and lowered, and the side and head lines in handling the dredge controlled.

"The 8-in. centrifugal pump is direct connected to a 50 H.P., motor, type CCL, constant speed, having a speed of 850 R.P.M. A 15 H.P. motor of the same type with a speed of 1120 R.P.M. is direct connected to the 4-in. centrifugal pump.

"The revolving screen with a speed of approximately 8 R.P.M. is operated by a belt from a 20 H.P., type CCL, constant speed motor, having a speed of 1120 R.P.M., and connected by belt to the drive of the conveyor. As stated, this is of the Robbins type, equipped with a 30-in. special Diamond Dredge belt, the entire con-

veyor being 102 ft. between centers. As originally installed it was only 90 ft., but it was found necessary to lengthen it. All the electric motors were manufactured by the Westinghouse Co.

"When all drivers are being used 225 H.P. is needed, but this seldom occurs. The main drive motor, which operates the bucket, line and ladder hoist, is in use nearly all the time. The starboard winch motor is used more or less intermittently, only when it is necessary to raise and lower the spuds, or the stacker, or swing the dredge from side to side. The pump motors are used constantly in supplying water for the revolving screen and tables, also for the bucket washing apparatus, where the buckets jump at inversion at the upper tumbler. Both revolving screen and stacker belt motors are constantly in use, the one driving the revolving screen or "grizzly," as it is commonly termed, for properly screening the gravel, the other in connection with the stacker belt, which carries off the tailings. The digging buckets average speed is about 22 buckets per minute, this naturally varying according to the nature of the ground.

"From 90,000 to 110,000 K.W. hours are used per month on the dredge, making a daily rate of from 3000 to 3666 K.W. hours. The cost of current is 1 cent per K.W. hour.

"The entire cost of this dredge ready for operation was \$90,000.

"Such a dredge is operated during a monthly average of from 80 to 90 per cent of the possible running time. The dredge is operated 24 hours per day, with the three 8-hour shifts. All stops of whatever nature are counted in the average time made; for breakdowns of machinery, power shutdowns, and for cleaning up. A clean-up is made twice a month usually taking up four or five hours. The time is not lost entirely, as it is taken advantage of to make needed repairs. To obtain such running results, duplicates of all wearing parts must be kept on hand to be replaced with the least possible delay.

"Such a dredge is operated by two men, one being a winchman, the other an oiler. Many of the dredges employ a shoreman to dig deadmen and help in handling the shore line. In addition to these most of the dredges carry a dredgemaster.

"The wages paid to the men are as follows:

Dredgemaster.....	\$150.00 per month
Winchman.....	3.50 per day
Oiler.....	2.50 "
Shoreman.....	2.00 "

“The Hunter dredge, working 30 days a month, excavated 106,000 cu.yds. of very hard material with a large number of boulders in it. The cost of this month’s work was as follows:

LABOR:	
1 dredgemaster.....	\$150.00
3 winchmen, 30 days.....	310.00
3 oilers, 30 days.....	225.00
2 shoremen, 30 days.....	120.00
	<hr/>
Total.....	\$805.00
POWER:	
100,000 K.W. hours.....	\$1,000.00
Supplies, etc.....	210.00
PLANT:	
Interest, depreciation, and repairs (estimated).....	1,800.00
	<hr/>
Total.....	\$3,815.00

“This gives the cost per cu.yd. including our estimated allowance for plant as follows:

Labor.....	\$0.007
Power.....	0.009
Supplies.....	0.002
Plant.....	0.017
	<hr/>
Total.....	\$0.035

“This shows how wonderfully efficient these dredges are. It is also worthy of note how small a crew operates so large a machine. A company operating one or more of these dredges employs a blacksmith and helpers to make repairs and keep up the machinery, and also a superintendent who gives the work general supervision and is present at the semi-monthly clean-ups.

“It is found that large dredges are more economical than the smaller machines, and to-day the American practice is to use large capacity dredges. Some of the latest machines are equipped with 13 ft. buckets. These are operated by the same size crew as that given for the Hunter dredge, and although the cost for power is larger and the charge for maintenance and depreciation is greater yet the total cost is less. Some of the largest machines now built have averaged 260,000 cu.yds. of gravel per month, while some have even obtained a record of 280,000 cu.yds. This would mean a charge per cu.yd. for labor of only .00278 cts., a very low cost.”

The following cost data are extracted from the Mining and Scientific Press and are of value, as they cover a period of years.

"The costs given cover the operating expenses, the cost of all repairs necessary to keep the dredges in first-class working condition, and the cost of extraordinary breakages and accidents; all of which latter are properly included in dredging costs. Estimates of costs which do not include the last-mentioned items are to that extent fictitious.

1. "A dredge having $3\frac{1}{2}$ cu.ft. buckets, digging in ordinarily loose gravel and sand.

OPERATING COSTS IN CENTS PER CUBIC YARD

	Years.						Average for 6 Years.
	1	2	3	4	5	6	
Labor.	2.913	3.133	3.975	2.687	3.011	2.853	2.877
Power.....	1.886	1.960	2.467	1.542	1.446	1.487	1.655
Water.....	0.180	0.255	0.194	0.211	0.195	0.154
Repairs and supplies	2.415	3.383	2.624	2.515	2.395	1.717	2.480
General expense....	0.745	0.658	0.797	0.672	1.354	1.077	0.825
Total.....	7.959	9.314	10.118	7.610	8.417	7.329	7.991

2. "A 5 cu. ft. dredge, working in tight gravel and clay. The material should properly be considered as tough rather than hard.

OPERATING COSTS IN CENTS PER CUBIC YARD

	Years.				Average for 4 Years.
	1	2	3	4	
Labor.....	3.814	4.069	3.356	3.060	3.557
Power.....	1.912	1.815	1.622	1.425	1.687
Water.....	0.340	0.323	0.374	0.292	0.333
Repairs and supplies.....	2.709	2.788	4.297	3.062	3.246
General expense.....	1.260	0.959	1.124	1.145	1.124
Total.....	10.035	9.954	10.773	8.984	9.947

"Dredge No. 2, working in such ground as is No. 1, would operate at a total cost of about 5.59 cents."

CHAPTER XXVI

DREDGING FOR INDUSTRIAL PURPOSES—SAND DREDGING— DREDGING FOR FILLING UP LOW LAND

Sand Dredging for Commercial Purposes. Another industry based exclusively upon the work of dredges is the excavation of sand and gravel from the great rivers for commercial purposes. This industry was described by Mr. Richard G. Donovan in an interesting article contributed to the Engineering Record, Jan. 5, 1906, which is slightly condensed here.

One of the important industries on the Mississippi River and its tributaries is dredging sand and gravel for commercial purposes. These rivers carry an immense volume of sand, gravel and other matter which form large bars at locations where the current is checked. The annual floods also play an important part in the formation of these bars, for the high velocity of the river during these periods tends to erode the bed and side banks; when the floods decline the load is too heavy for the decreasing velocity, and the gravel and sand are rapidly deposited.

In the Ohio River at some localities gravel is found in large quantities with but a small percentage of sand, while in other places the bars may be entirely of sand. In the Pittsburg district the Allegheny River is noted for its fine clean sand, and most of the sand used in the district comes from this river. The sand from the Monongahela River, on the other hand, is dirty and contains injurious deposits from the numerous manufacturing plants along its banks. In the Mississippi River, as a rule, the bars contain fine, fairly clean sand of quite recent deposits. An immense amount of sand and gravel is taken from the rivers annually and the development of this business has resulted in the adoption of certain types of dredges to meet the peculiar conditions existing in the various localities. Those more commonly employed are the hydraulic, the ladder and the grab-bucket dredges.

The Hydraulic Dredge. The hydraulic dredge has been used extensively in removing sand-bars along the Mississippi River, and the private concerns engaged in dredging sand for commercial purposes have found these machines efficient.

The hull consists of a scow of the light-draft square type, of heavy construction, being, as a rule, housed over and arranged with suitable quarters for the crew. The dredging end of the hull is provided with a strong A frame to support the suction head, which projects beyond the hull. The other end is provided with means for the proper handling and anchorage of the dredge. The dredging end is usually downstream—see Fig. 77.

The pump used is of the centrifugal type with a runner provided with four curved blades. The runner is closely fitted to the casing, and this is necessary in order that the discharge may not leak back into the suction. In the operation of the pump in sand or gravel dredging, the question of wear is an important one, and in the latest designs the runners are of steel and large space is provided in the discharge volute. Of course no sharp bends should be allowed and the passages in the pump should be larger than the suction pipe so as to prevent obstruction by stones.

In many dredges special arrangements are provided for stirring up or agitating the sand at the suction end. This is usually accomplished by directing strong jets of water into the sand, resulting in the upheaval of the latter, which is caught up by the suction and drawn into the suction pipe. The discharge from the pump is arranged so that the barge moored on the side of the dredge may be conveniently filled. An open discharge trough with screen of any desired mesh in the bottom is suspended over the barge so that any stones or coarse gravel may be washed past and discharged overboard. The operator whose duty is to feed the suction head in the sand is situated so that he can see the barge and regulate the depth of the suction head by observing the discharge mixture.

The centrifugal pump is usually driven by a compound steam engine, of either the vertical or horizontal type. As a rule, the dredges operated by the larger companies have a double equipment, consisting of a pump on each side, so that barges may be loaded on both sides. A powerful hoisting engine is provided for raising the suction head, and steam power is applied to the capstans and other handling machinery. As a rule the Mississippi River type

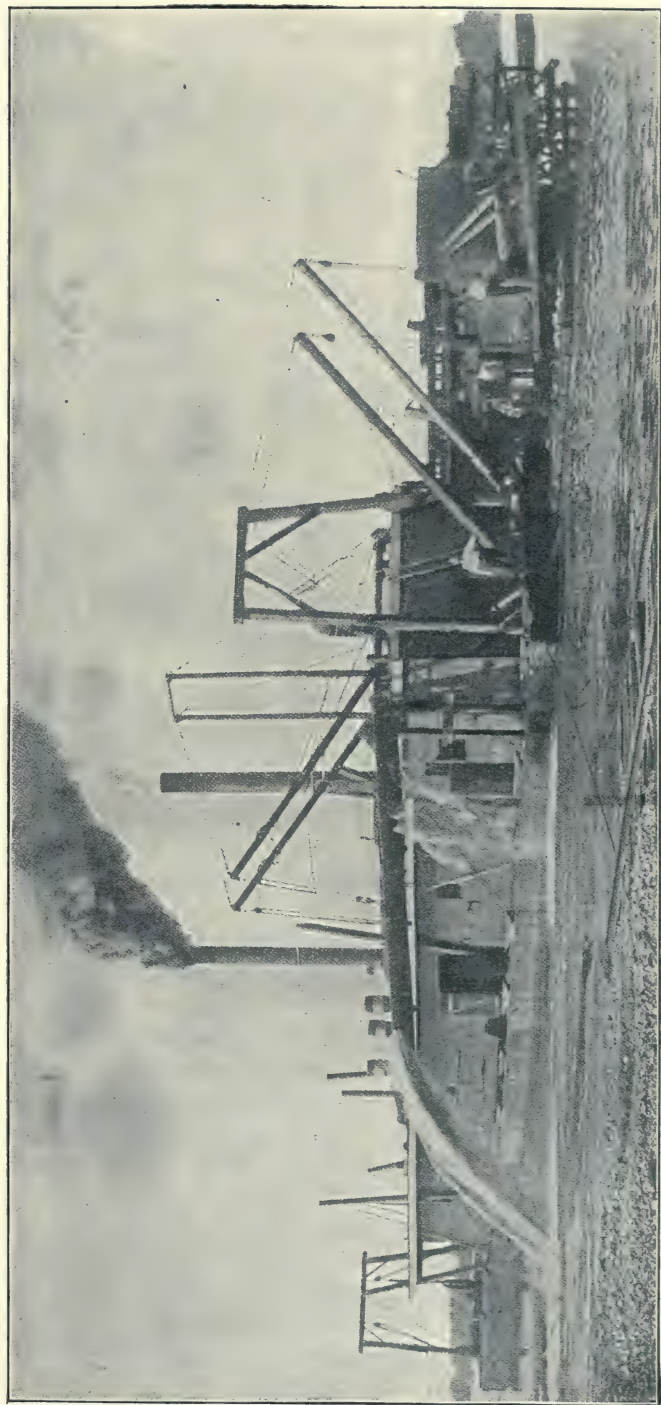

Fig. 77.—Hydraulic Sand Dredge.

of boiler is used, and all these commercial dredges are of the non-propelling type.

The Ladder Dredge. For the excavation of gravel in the upper Ohio and Allegheny Rivers the hydraulic dredges are not found suitable owing to the fact that the material will not readily flow into the end of the suction pipe and the wear on the pump and other parts of the machine would be simply enormous. For such work the ladder or elevator type of dredge is well adapted, and in fact, almost all the dredges operated by the sand companies in the upper Ohio and Pittsburg districts are of this type. Fig. 78.

The hull used in this type of dredge is of the usual square barge construction. It is built of wood with heavy timber frames, thus securing great strength and stiffness. The dredging apparatus



FIG. 78.—Ladder Sand Dredge.

is usually arranged on the side, since this results in cheap construction, and allows a more compact arrangement of machinery. The hull is housed over and frequently quarters are provided for the crew. Some of the dredges are self-propelling, the dredging apparatus being fitted on the side of a stern-wheel river steamboat.

The ladder is of very strong construction; as a rule, it is of timber with steel bracing. The members forming the ladder are connected by bracing, and at their upper end by a shaft which is carried in a frame forming part of the hull, so as to permit the ladder to revolve and change the position of the lower end.

The top tumbler construction is of great strength, as it is here that the power is applied to the conveyor system and the cutting resistance overcome. The buckets forming the conveyor system are usually of steel plates riveted together by a chain formed of

steel bar links pinned at their ends so as to allow them to work around the tumblers. Roller bearings are fitted along the ladder at intervals to insure uniform support to the train of loaded buckets. The material is cut out and carried up the ladder and dumped at the top tumbler. The empty buckets are returned toward the bottom without support so that the empty train in motion hangs suspended between the top and bottom tumblers. The sand and gravel are separated by a moving screen, which is so arranged that the coarse gravel may be loaded on one side of the dredge and sand on the other.

The machinery used in the non-propelling type of dredge usually consists of boiler and engine equipment of sufficient power to operate the conveyor system and provide power for capstans, syphons, etc. The transmission of power to the ladder is generally made through chain gears and the raising and lowering of the dredging end of the ladder is performed by a lifting device operated by power from the main engine. Steam capstans are provided for handling the barges and for changing location by using the mooring lines. In the propelling type of ladder dredge the boiler equipment must be of sufficient capacity to operate both the dredging and propelling machinery. The latter consists of the usual stern wheel equipment, which of course is entirely independent of the dredging apparatus.

The Grab-bucket Dredge. The use of the grab bucket or clam-shell in sand dredging for commercial purposes is very limited. This type in the relatively shallow rivers cannot be operated as economically as the other types discussed, since its speed is much lower and the nature of its operation necessitates elaborate details for the screening of the sand or gravel. However, as illustrating a novel method of using the grab bucket, attention is called to the figure showing such an apparatus for digging gravel direct from the river bed. The apparatus travels along the broad gauge track on the river bank and the cars to be loaded are run under the machine. The grab bucket travels out on the overhanging arm, and on being filled is carried back and the gravel dropped into the cars.

Method of Handling Sand. In transporting the sand or gravel from the dredge to the unloading station, two types of carriers are used, the decked barges and the open-hold barge. In the Mississippi River sand business with the centrifugal dredge, the decked type is exclusively used, while in the upper Ohio district where

the elevator or ladder dredge is used the open-hold barge is the standard type.

For the efficient operation of the centrifugal pump it is necessary that there be a large percentage of water in the sand. On the other hand, it is necessary for the economical handling of the sand that it be as free from water as possible. The decked barge with cargo box has been designed to meet these conditions. The cargo box is formed by fitting sideboards about 3 ft. high and arranging hopper ends, inclosing nearly all the deck area, leaving but a small space at each end for handling lines. The barge is placed alongside the dredge and the mixture of sand and water from the centrifugal pump is directed into the inclosed deck space.

These decked barges are subject to very severe usage in the operations of handling and unloading. The large sand companies operating on the Mississippi River have installed unloading machinery of the largest capacity with corresponding weight of parts. The immense grab buckets come down on the deck with considerable shock, causing heavy local stresses, so that the deck supports must be close together and of ample section. In unloading, it is also necessary at times to take out the sand very unevenly, such as removing it from one end only, or from the middle, giving rise to heavy longitudinal bending stresses, which must be provided for by continuous longitudinal bulkheads. This service tells heavily on the wooden barge, and its upkeep is a matter of considerable expense and ultimate renewal after a comparatively short life.

With the increasing use of steel for river-boat construction, several steel-decked barges have been placed in service by one of the largest sand companies on the Mississippi River. These barges are 130 ft. long, 30 ft. wide and $7\frac{1}{2}$ ft. deep. A complete steel deck is fitted, and on this a wood box is arranged by fitting timber sideboards 3 ft. high. The deck beams are framed longitudinally so as to better care for the impact of the grab bucket, which is used with its cutting edges across the barge. Longitudinal strength is secured by a system of lattice girders carried full length, while the transverse strength is provided for by a system of cross trusses. The deck beams are supported at close intervals by the cross trusses, and by extra cross beams carried by the side frames. Channel sections are used to a large extent in the framing, which is spaced rather closely throughout the barge to insure strength and stiffness.

These barges have a capacity of about 400 cu.yds. of sand and draw about 6 ft. 9 in. in the loaded condition. They have demonstrated their ability to withstand the severe service and are much more economical in operation than the wooden type. Of course the steel construction costs considerably more than the wood, but when depreciation, cost of upkeep, and interest on investment are considered, it will be seen that the steel barge, with its life triple that of the wood, is the better business proposition.

In elevator or ladder dredging, the open-hold barge is used to receive the sand or gravel. From the nature of this dredging, practically no free water is carried into the barge, and it is only necessary to provide a suitable open carrier. As a rule, these barges do not have to meet the severe conditions incidental to Mississippi River dredging. The distance they are towed is usually much less and the unloading machinery is not of such heavy type. The barges, however, are of substantial construction and are well adapted to the service. The common carrier used in the Pittsburg district is about 100 ft. long, 24 ft. in beam, and has a depth of 8 ft., and a capacity of about 175 yds.

Unloading Machinery. The usual arrangements provided for the reception of the sand from the barge consist of elevated bins situated conveniently on the river bank in connection with some type of unloading device. These bins are usually so arranged that cars or other means of conveyance may be loaded readily. In the type of unloader much diversity exists, but the illustrations show some of the most modern Mississippi River stations with their machinery. These structures are of steel. Steam and electric power are used, and manual labor is reduced to the minimum. In unloading the barges, no attempt is made to clean out the cargo box beyond the action of the grab bucket. These buckets are very heavy and at times much injury is done the deck by allowing them to descend too rapidly. The capacities of the buckets vary from 2 to 4 yds. and the speed in operation from 75 to 150 yds. per hour. At some of these plants the sand or gravel is carefully screened into different grades for various purposes. In the upper Ohio district the unloading stations are not built on such a large scale and the unloading machinery is not of such large capacity nor of such elaborate parts. Some of the unloaders consist of a boom derrick and bucket which is swung into the barge and filled by hand, while others consist of a medium-size grab bucket operated by boom derrick. Storage

bins are seldom used, and in many cases the bucket loads are dumped directly into wagons or cars, or else the sand is piled along the bank.

Fig. 79 illustrates some of the machines for unloading barges along the Mississippi River.

Filling Marsh Lands. The transportation of the excavated materials to the dumping place is one of the most expensive items of dredging. Engineers have devised schemes, not only for eliminating this item of expense, but if possible to obtain some benefit from this bulky and otherwise useless material. Small drainage canals have sometimes been excavated at a very low cost owing to the



FIG. 79.—Machine for Unloading Sand from Barges.

fact that the *débris* was deposited directly alongside the cut, thus entirely eliminating their transportation. Some harbor and river improvements have also been made at a comparatively small cost on account of using the dredged materials for filling up lowlands located along the water front. In a few instances dredging operations have been made profitable by reclaiming either for agricultural or industrial purposes some marshy lands which were not only valueless, but dangerous to the health of the surrounding population as breeding places for mosquitoes. But in these particular cases the filling up of lowlands was of a secondary importance.

It is only recently that dredging has been undertaken for the

exclusive purpose of reclaiming low and marshy lands in localities near large cities. In these cases hydraulic dredges are employed to excavate the materials from the bottom, raise them to the surface and convey them to the lands to be filled by means of long lines of pipes. Thus in the year 1885 the dredge "Badger" was used at Coney Island, N. Y., to fill up some lowlands which were sold at a high price for amusement and residence purposes.

In the *Engineering News*, June 13, 1901, was given a description of filling up tide-water flats at Seattle, Wash., which is given here in a condensed form.

The city of Seattle, Wash., is built upon the hills lying between Puget Sound and Lake Washington, there being very little

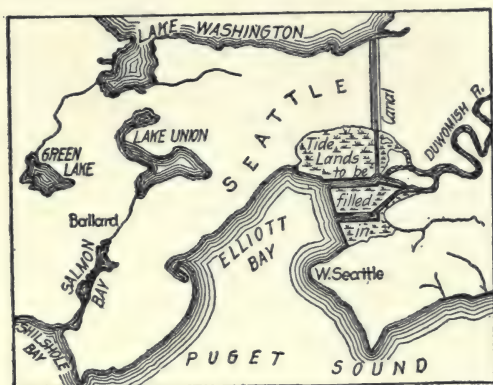

FIG. 80.—Tide Lands at Seattle.

flat ground for manufacturing purposes. Between the city proper and the suburb of West Seattle is a large area, a portion of Elliott Bay which is overflowed at high tide, but which is entirely bare at extreme low tide; the variation from mean low water to extreme high tide, being 16.7 ft. These tide flats have been filled with material taken from two waterways as indicated in Fig. 80, each one 1000 ft. wide and 30 ft. deep at low water. These waterways connect toward the South with Duwamish River and with a third waterway running east from the southern end of the east waterway to the foot of the hill, where it connects with the projected ship canal which is to be 140 ft. wide and 30 ft. deep to Lake Washington. The difference in level between low water at the

lake and high tide in the bay is to be overcome by a lock at the western end of the highland section.

The general plan of operation is to construct bulkheads along the margin of the waterways and fill in limited areas behind it by hydraulic dredges, thus creating impregnable restraining works, and inclosing vast interior settling basins to be filled with material from the highland section. Contracts have been made, so that when the construction of the bulkheads with their backing has progressed to a sufficient extent, work will be begun on the highland section, by installing powerful machinery for loosening the material by water under high pressure, and transporting it by the water in flumes and pipes, to the embankment on the tide flats. Material from the highest parts of the hill will be carried to the remotest districts, and the districts near by will be filled from the lower levels, so as to make use of gravity for transportation.

The average cost of filling these tide lands with solid materials is much less than the average cost of the perishable structures of wood and piles now used to sustain frame houses over the water. The land created in this way will furnish hundreds of acres of building sites, which will be traversed by railways, and abut upon deep water, thus affording a manufacturing district which will not be excelled by any city of the United States.

A remarkable feature of this enterprise is that these gigantic and beneficial works will be accomplished without any tax on existing properties. The values that are to sustain the charge are created by the operation that changes the bottom of the bay, which as such is worthless, into dry land, and adds, out of nothing, to the taxable values of the city, in a ratio of three to one of the cost of the improvement.

The work was carried on by the Seattle & Lake Washington Waterway Co., with Mr. Eugene Semple as president, who made a contract for the execution of the work with the Puget Sound Bridge & Dredging Co. of Seattle, Wash.

Dredging for the sole purpose of filling up valuable lands has been, in the last few years, undertaken in many places, but chiefly in the neighborhood of New York. The increased valuation of lands surrounding the largest cities, owing to the great facility of transportation, has invited speculators to create new towns and villages, and many old-time farms have been cut up and sold in building lots. The boldest of all these speculations is the construc-

tion of an entire new city along the shores of the Atlantic Ocean and within easy reach of the cities of New York and Brooklyn. It will be a new summer resort to rival Atlantic City, and yet at a commutation distance from New York, so as to be used also for residential purposes all year around. The new city is located on Long Beach, Long Island. The lowlands which surround Long Beach have been filled up with sand removed from the shallow bottom of the ocean by two hydraulic dredges, and the material conveyed through a long line of pipes. The dredges have dug also a navigable channel between the ocean and the large body of water existing between the mainland and Long Beach, thus permitting large vessels to enter and approach the surrounding lands, which will be improved for industrial purposes. Considering the selling prices of the building lots the dredging is certainly remunerative.

Similar work to this in an extensive manner has been done at Cape May, N. J.

Still another example of undertaking dredging operations for the exclusive purpose of forming new lands, is at Governor's Island, the headquarters of the Department of the East of the United States Army. Governor's Island being a comparatively small island just south of New York city and occupied by the various buildings for offices, officers' residences and barracks, there is no room for a parade ground, where the garrison can be drilled, reviewed, etc. Adjoining islands are already taken up for various purposes and are crowded with costly and important buildings. Hence it was decided to extend Governor's Island. Strong masonry bulkhead walls on the eastern and western sides were built and extend for nearly half a mile in a southern direction, with another bulkhead wall built across the two, thus forming a rectangle of nearly one-half mile long by one-half mile wide. This southern bulkhead wall had a gap left in the center to be closed afterward. Two hydraulic dredges are employed to deepen the bottom around the island and deposit the dredged material between the new bulkheads. Thus the harbor will be deepened at the same time new land is formed.

In this connection it has been suggested by one of the engineers of the Dock Department of New York city, that the city build a bulkhead so as to take in the entire area of water between the Battery and Governor's Island and also to a point south of the island for some distance, and by means of dredges reclaim this large area for city purposes. The docks alone gained in this manner

would be of great value to the city, while many city blocks would be regained for the city to sell, besides space for park and pleasure places. It is also stated that land could thus be obtained for the center pier of a large suspension bridge to run from Jersey City to Brooklyn. Such a proposal seems visionary, but the work already done at Governor's Island is a part of this scheme, and with New York city's rapid growth, no one can tell but that such a proposal may be adopted within the next decade. It would be a work of magnitude, but few difficulties would be encountered.

CHAPTER XXVII

DRY-LAND DREDGING

WITHIN the last decade dry-land dredging has been done extensively in America. This is not in reference to excavation work by steam shovels, but to excavation done in a manner somewhat similar to ordinary dredging. This work is done for various purposes, as the building of dykes or levees, the excavation of canals, power ditches, dams and reservoirs, irrigation and drainage ditches.

The machines used for such work may be divided into two classes. First, types of machines similar to those used in ordinary dredges. These are mostly the dipper, grapple and hydraulic suction type, although a few dredges of the ladder type have been used. One such has lately been used in the state of Idaho, in excavating irrigation canals. The dredge is of a fair size, and is operated by a gasoline engine. At first its work was indifferent, but after being rebuilt it has done efficient work.

Hydraulic dredges are not used extensively, but more so than the ladder type for dry-land work. To use it a hole large enough to float the machine must be excavated by other means and be filled with water. A supply of water must be furnished to allow the dredge to work. Unless the work is situated close by a river or large body of water the needed water is difficult and expensive to obtain, hence it is only possible to work the hydraulic dredge under special conditions. Land however is sometimes flooded and excavated with such dredges. This was one of the methods suggested to excavate the Culebra cut on the Panama Canal but it was not adopted. Other objections to the use of hydraulic dredges for dry-land work are the necessity of finding a place to deposit the dredged material and the great volume of water necessary to carry it. On harbor and river work this material is either pumped into another part of the harbor or river, or else used to fill up adjoining lowlands so the water does not do any damage, but for dry-land work, even if there is a place to deposit the dredged material, yet

the water is liable to do damage to nearby property. At times centrifugal pumps are used to excavate foundation pits and coffer-dams. Such pumps are mounted on platforms or skids, and are, as a rule, of a smaller size than those used on dredges.

Grapple dredges are used quite extensively for dry-land work. Both clamshell and orange peel buckets are used on these machines. In some cases the hoisting machinery is simply mounted on a moving platform or skids or gunwales and the bucket is operated on a derrick. The whole machine is moved either on rollers or wheels, and is operated by a crew of three or four men. Even sewer trenches are excavated with such an apparatus, and besides the various kinds of work previously mentioned, railroad embankments and levees are sometimes built with such a land dredge. On extensive work such machines are often worked in pairs. Such dredges can work in hard as well as soft materials, and will work both in dry and wet excavation. These buckets are also used in foundation work, to excavate inside of coffer-dams.

Grapple dredges mounted on scows are also used on dry-land work, but not as extensively as dipper dredges. When there is no water to float them at first, a pit is dug and water pumped or turned into it. Both are used in a manner similar for such dredges in rivers, except in canals and ditches that are but little wider than the scow, the spuds are outrigged in a manner somewhat like the jack arms of a steam shovel, and are held in place on the banks of the ditch. Such spuds are called "bank spuds."

Dipper dredges used for such work vary in size from dippers of 1 cu.yd. or less up to 10 or 12 cu.yds. As a rule the excavated material is deposited on the two banks.

Another type of bucket used for dry-land work is shown in Fig. 81. These are used on long derrick booms, and in some cases by means of a deadman set ahead of the machine material beyond the reach of the boom is excavated. Such buckets are in nearly all cases patented. The best known are the Page, the Channon, the Heyward, the Browning, the Austin and the McCormick. Sometimes the derricks are mounted on scows and then used as a dredge for ditch or canal excavation. Locomotive cranes are also used to operate these buckets, as well as orange peel and clamshell buckets. Some manufacturers also rig them to take a dipper arm and steam-shovel dipper, but when so equipped they are classed with steam shovels.

The second class of dredges used for dry-land excavation are machines designed and built for this particular kind of work. One of the best known of these machines is the Austin Drainage Excavator, built by a company of that name, in Chicago, Ill. This machine straddles the ditch or canal and excavates a clean ditch with sides sloped to any desired angle, see Fig. 82. Digging with this machine is often termed "excavating a ditch to a template."

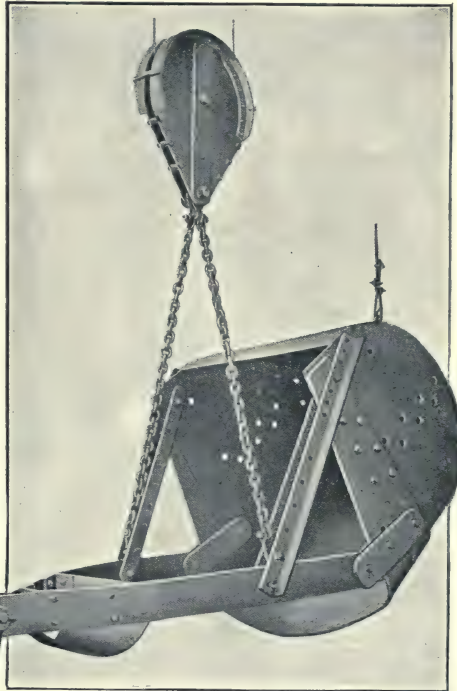

FIG. 81.—Bucket for Dry-land Dredging.

A steel framework upon which the two buckets operate is made to conform to the bottom of the ditch and extend to either side, so that the earth is carried away from the sides of the ditch, leaving a berm that is free of earth, and thus preventing it from running back into the excavation. In this manner two regular levees are built, one on each side of the ditch, that act as banks to confine the water in case of floods. The berm left is from 10 to 15 ft. wide. The frame under the machine is lowered as the ditch is deepened.

The buckets travel forward and backward on the frame, cutting off a thin slice of earth from the sides and bottom. As one bucket is being dumped the other is loading. The excavation can be made either in the dry or under water. No dirt is left in the bottom, the buckets cleaning it up as the machine travels along on two rails, one on either side of the ditch. As the dredge travels on rails a perfectly straight ditch can be dug. It can also be mounted on a walking device or on a scow, but its best work is done when operated on rails. The guiding frame can be raised above the surface of the

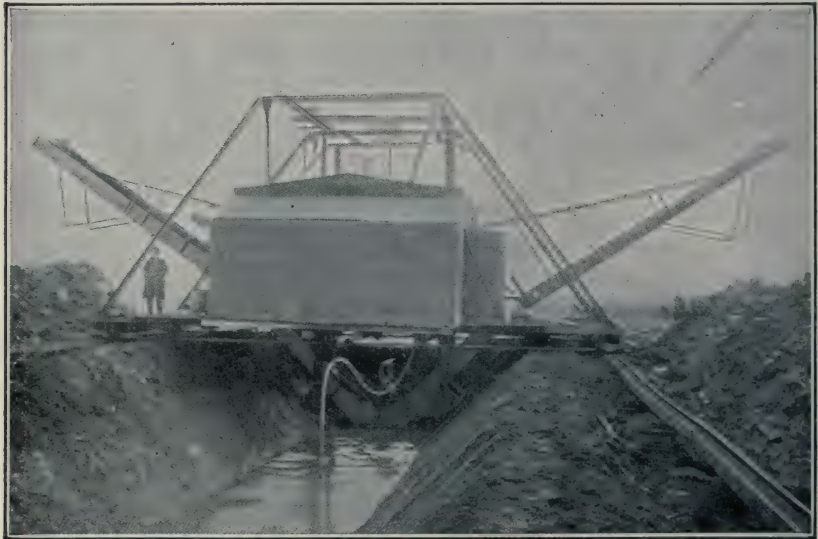

FIG. 82.—The Austin Drainage Excavator.

ground, and thus be moved across the country on its own rails, traveling under favorable conditions about a mile per day.

J. W. T. Stephens of New Orleans, La., is the inventor of a small dredge for ditch and canal work. It might be classed with the ladder or elevator type of machines. The chain of buckets is hung from a boom and discharge onto belt conveyors, depositing the material onto either bank. Bank spuds or arms hold the dredge or scow in place. The boom can be raised or lowered and swung from side to side, covering 180° of circle, so that from one position of the boat, a large amount of work can be done. The

banks of the ditch can be sloped as the ditch is excavated with this machine.

The Fairbanks Steam Shovel Co., of Marion, O., manufactures a ditching machine known as a "walking dredge." Such a machine is meant for ditch work where there is not enough water to float a boat. The machinery is placed on a timber hull that reaches over the constructed ditch. The boom is operated by a turntable, and attached to the boom is the scraper-like shovel, with a capacity of from 1 to 2 cu.yds. The long scraper arm reaches down into the ditch, and the bucket or scraper is filled by means of a drag line from the engine. The scraper has two bails and two lines on it. The second bail keeps the bucket in an upright position while being loaded, and by releasing the line the bucket is dumped. The machine is named from the method of moving it over the ground.

Another type of walking dredge has been used in Minnesota on drainage work. This machine has a second boom, known as the walking beam, suspended from the boom. The scraper or bucket is attached to this second boom, and instead of working toward the machine, it works away from the dredge when loading. This is done by means of a chain attached to the walking arm, and the load is released by a chain on the other side of the arm. The following description is taken from the bulletin of the Northeastern Experiment Farm of the University of Minnesota.

"The peculiarity of this machine is the method of moving. Under each corner is a timber platform the shape of a stoneboat, called a foot. Each of these corner feet is 6 ft. wide, 8 ft. long and 4 in. thick. They are joined together transversely by a light timber. This requires them both to move in the same direction, the direction being controlled by a chain which runs from each corner foot to a drum that is operated by the cranesman. Near the outside of each corner foot there is a knife made of iron, $\frac{1}{2}$ in. thick by 6 in. wide and 6 ft. long, which prevents the foot slipping sidewise. Midway of the machine on either side is a center foot 6 ft. wide, 14 ft. long and 6 in. thick. On the under side a 6×6 in. timber is bolted crosswise, to prevent slipping back. This foot is attached to a heavy triangle frame, free to move longitudinally between the double side frame of the hull. A chain, the end of which is attached to the side timbers of the hull, passes over two pulleys in this triangular frame and then passes along the hull to the back

corner and across the back end to a drum which is located about the center of the hull. When it is desired to move the machine the power is turned on to this drum and the chain wound up. As the chain tightens, the hull of the machine rises, the weight coming on the center foot. The winding on the drum is continued until the weight in lifting the hull becomes greater than the friction at the corner feet, when the entire hull moves ahead about 6 ft., although an 8-ft. move can be made. The chain is then released, taking the weight off the center foot, which is pulled by another chain attached to a drum in the front part of the hull."

This machine has moved across country at the rate of 1 mile in 11 hrs. The dredge has excavated 7 scrapers of earth and moved ahead 6 ft. 8 in. in 7 minutes. This is said to be an average speed. Difficulty is experienced in excavating in soft material, and also in making short turns with the machine, owing to cave-ins.

In the same bulletin is described the Junkin ditcher, which consists of a car running on rails, one on each side of the ditch. As in the Austin machine a steel frame extends under and over the machine, and is operated in a somewhat similar manner.

"At the back of the car, transversely to the direction of the ditch, is a triangular-shaped cutting frame, the lower part of which is constructed to conform to the bottom and slopes of the proposed ditch. Over each half of this frame are two chain belts 30 in. apart, and between these belts are riveted at equal distances 14 buckets, which excavate and carry the material. The cutting edge of these buckets can be detached from the main part for sharpening if occasion requires. The buckets over each half of the frame travel in opposite direction, so that each set passes up the slope of the ditch, where it does the excavating. Their direction is changed at the apex of the triangle by sheaves, each bucket making a complete revolution every 45 seconds, although in easy digging they can run at a speed of two revolutions per minute. The excavating frame can be put together in such a manner that it will cut a narrow or wide bottom, or different slopes. The excavated material is cut up very fine and deposited on either bank. The spoil banks have uniform slopes coming to a sharp edge at the top."

The dredge excavates a strip 30 in. wide at one time, and as it leaves a ridge in the center of the ditch or canal, after making an advance of 30 ft. it goes back to clean up the slopes and the loose material it leaves. The ridge can be shoveled out by hand

or left to be washed away by the action of the water, extra material being taken out so as to bring the bottom back to grade.

The straddle ditching machine is built by Mayer Brothers, Inc., of Mankato, Minn. It is mounted on two steel beams that straddle the ditch to be excavated. The four ends of these beams are provided with a two-wheel oscillating truck, which runs on plank ways, 6 in. thick and 3 ft. wide, built in 20 ft. sections. These plank ways are moved forward by two special cranes provided on the dredge for that purpose. The whole machine is moved ahead by means of a cable run to a deadman in front, without interfering with the work of the dredge. In other respects the straddle ditching machine is like a dipper dredge.

A number of steam-shovel manufacturers make some types or type of ditching machine to be mounted on a scow for working either for dry-land excavation or when there is water. These all have dippers and we need not comment on them further.

It is but natural that most dry-land excavation is done by other means than dredges, but dredges are being used more and more for such work, as it is found to be economical, especially when large quantities are to be moved. Another method of dry-land excavation is by means of a jet of water. This is known as hydraulic sluicing and is done by means of a nozzle, known as a monitor or giant. This method is used also for mining, and earth is loosened and in some cases elevated by means of hydraulic elevators, which are described elsewhere.

The Chicago Drainage Canal, built during the nineties, was a case of dry-land excavation, upon which many different classes of machines were used, including dredges, steam shovels and cableways. A large number of special machines were also designed for this work, and when grapple buckets were used on them, they could be classed with dredges, but the majority of such machines were designed to dispose of the spoil and not to excavate it.

The rebuilding of the Erie Canal in New York State into a 1000-ton barge canal, is also another example of dry-land excavation that has brought out special machines, and a number of large dredges for carrying on the excavation. Power scrapers are being used both with movable derricks, derrick cars and cableways, and grapple buckets have been operated by means of a large steel overhead bridge near Rochester, N. Y.

The Panama Canal is the greatest undertaking that the world

has ever seen in connection with earth and rock excavation. Steam shovels and dredges are being used for this work almost exclusively. The dredges are of the suction, ladder, and dipper type. Some are of the hopper type. In spite of the fact that this is the greatest job of excavation undertaken by man, there have been no new types of machines invented or designed for the work, owing to the fact that the U. S. Government is doing the work by day labor, instead of employing contractors, who would no doubt have reduced the cost of the excavation by using machines designed especially for the job in hand.

CHAPTER XXVIII

THE COST OF OPERATING DREDGES

THE cost of dredging, like that of any other engineering work, should be deduced from an accurate analysis of all the various operations required for the work. Some of these expenses are very apparent, recurring continuously in the execution of the work, while others, and perhaps the most important, do not occur simultaneously with the work, but at long intervals between one another, thus they are detected with more difficulty and in many cases observed.

Some engineers and contractors, in preparing estimates for public works, rely almost exclusively upon the prices that were paid for works executed under almost similar circumstances, this method of determining the cost of work very often leading to errors. Prices will give but little idea of costs, unless the profit realized by the contractor can be learned. Since such information can hardly be obtained, it is evident that prices are hardly a guide for bidding on new works. Besides, in dredging it is difficult to call work similar, owing to the different conditions of depth, magnitude of the improvement, quality of soil, whether the dredging is to be done in the open or in sheltered places, the character of the plant and other details. Useful information concerning the cost of dredging may be obtained from the annual reports of the Chief of engineers of the United States Army. In them is given the cost of various improvements in different sections of the country. There are at present many government dredges engaged on difficult works about the country. These dredges are handled by experienced engineers and crews and their work may certainly give an approximate idea of the real cost of dredging. But even such data should be taken with great caution, owing to the fact that the reports frequently do not include expenses which should be charged to the work. Thus, for instance, the salary of engineers, the tugs or motor boats for the service of engineers and crews, the cost for piers, the cost

UNIVERSITY OF CALIFORNIA
DEPARTMENT OF CIVIL ENGINEERING
LIBRARY

of coaling and repairing the dredges, office expenses and other items. These are not charged to dredging in the government reports, while they are very expensive items to a contractor. Another item which the government reports do not show is the contractor's profit, which must cover his own work and the risks he must incur. Also, the interest of the money invested in the plant is given too low in the government reports, as it is evident that a private contractor cannot obtain money at the same low interest as the government. Hence even the accurate data furnished by these annual reports should be handled with great care by engineers and contractors.

The proper way to correctly determine the cost of dredging is to make an accurate analysis of all the items of expense required for the work under consideration. The expenses of dredging may be classified in two groups, namely: those concerning the plant and the general expenses required for the execution of the work. In regard to the plant the expenses can be again divided into operating expenses or those required every day for the running of the dredge, and into yearly expenses, being interest and depreciation on the plant and interest on the capital invested. These must be prorated over the length of the season worked.

Operating Expenses. The field or operating expenses include all the expenses required for running the plant in such a manner as to obtain the greatest efficiency with the minimum effort. The operating expenses include those absolutely necessary for the removal of materials from the bottom, as well as those required for the transportation of the dredged materials to their final destination. Thus the operating expenses vary with the machine employed and the method of transportation of the *débris*. In the hydraulic dredges as well as in the dredges of the sea-going hopper type the principal expenses are those required for the handling of the machinery to keep it in perfect working order; but when the materials must be transported on scows, towed by tugboats, besides the running expenses as indicated above, there is also the cost of hauling the scows. Thus in regard to the operating expenses a distinction should be made concerning the character of the machine employed—as dredges of the hopper type; dredges in which the transportation of the material is effected by scows towed by tugboats, and dredges in which the *débris* is conveyed to land by means of pipes or other devices.

In the sea-going hopper dredge the most important operating expenses are the wages of the officers and crew handling the machine. As a rule there are always two crews on board of these steamer dredges, in order to work continuously day and night. Other important items of expenses are the consumption of coal; the repairs which are absolutely necessary to keep the machines in good working order; the subsistence of the crew and officers compelled to live on board the steamer; besides miscellaneous supplies, as water, etc. In the sea-going hopper dredge either of the hydraulic or ladder types, the various items of the operating expenses are more or less in the following proportions:

Wages.....	33%
Coal.....	25
Repairs.....	25
Subsistence.....	10
Miscellaneous.....	7
	<hr/>
Total.....	100%

When the dredged materials are transported to the dumping place by means of scows towed by tugboats, the cost of transportation represents the highest item of the operating expenses. Dredges served by scows as a rule work only in daytime, consequently one crew is sufficient to handle the machine during its work; thus the expenses concerning the wages of the crew and their subsistence are comparatively small. In general it may be said that in dredges served by scows the various operating expenses are in the following proportions:

Transportation of scows.....	40%
Wages.....	22
Repairs.....	18
Coal.....	12
Board.....	6
Miscellaneous.....	2
	<hr/>
Total.....	100%

In dredging, the coal consumption is comparatively a small item when compared with other expenses. Consequently high-tower ladder dredges are not as uneconomical as they seem, and could be more extensively used to advantage in some particular cases. For making a rough estimate the coal consumption can be figured about 1 cent per cubic yard of dredged material, provided the price of coal is \$3.00 per ton.

Repairs represent another important item of expense. They should include only the repairs that occur almost every day and are necessary for the continuous working of the machine. They do not include the general overhauling of the dredge, generally done once a year or at the close of the season. Mr. Babcock, discussing this item of expense in connection with the hydraulic hopper dredges "Manhattan" and "Atlantic" states that the value of the time lost due to repairs far exceeds the actual cost of the repairs. He calculates that the value of time lost by reason of repairs in eleven months was \$110,538, while the money actually paid for these repairs was only \$43,721.

The total amount of the operating expenses in a month, season or year divided by the total quantity of material removed in the same length of time, will give the cost of the unit of volume of the excavated material. It is evident that all items of expense remaining the same, the greater the amount of material excavated the smaller will be the cost per unit of volume. Numerous delays from various causes tend to increase the cost. Thus it may be said that the operating expenses, per unit of volume, are inversely proportional to the quantity of material removed, and directly to the delays. The following table, taken from *Engineering*, June 19, 1903, shows the percentage of time worked and the delays for an average of one year's work, of several dredges of different types employed on improvement work in New South Wales:

	Twelve Ladder Dredges.	Ten Hydraulic Dredges.	Seven Hydraulic and Grab Dredges.	Twelve Grab Dredges.
Dredging.....	63%	49%	61%	62%
Coaling.....	2	2	2	3
Removals.....	9	14	16	8
Bad weather.....	3	2	2	3
Waiting points.....	3	2
Repairs.....	19	25	16	15
Other causes.....	1	1	3	7
Taking silt to sea.....	...	7
	100%	100%	100%	100%

For the time occupied in the various operations by the hydraulic hopper dredges "Manhattan" and "Atlantic," working eleven months each, from July 1, 1905, to May 31, 1906, as given by Mr. Babcock, in *Engineering News*, see Vol. LVI, p. 306:

	Whole Days.	Parts of Days.		Total in Days of 24 Hours.	Percentage.
		Hours.	Minutes.		
Actually at work		8041	38	335.1	50.0
Repairing	112	628	05	138.1	20.6
Fog and snow		272	40	11.5	1.7
Storm	6	177	15	13.4	2.0
Taking on coal, etc., minor repairs and clearing up; parts of Saturdays and Mondays		1102	37	46.0	6.9
Miscellaneous		89	35	3.7	0.6
In July, 1905, before night work began		294		12.2	1.8
Sundays and holidays	110			110.0	16.4
				670.0	100.0

In the dredge "Fin MacCool" employed at the Buffalo Breakwater during the season May–October, 1899, working from 12 to 14 hours per day, the proportion of the time employed in dredging and that lost in delays, was, according to Mr. Emile Low (Engineering News, October, 1906), as follows:

	Time Worked.		Time Delayed.		Number of Days.	Length of Days in Hours.
	Hrs.	Min.	Hrs.	Min.		
May	190	37	131	23	23	14
June	232	11	131	49	26	14
July	211	40	152	20	26	14
August	255	31	122	29	27	14
September	133	12	206	48	24	14
October	98	02	55	46	13	12
Total	1121	13	800	35	139	

which shows that the time employed in dredging was 58 per cent, while 42 per cent of the total time was lost in delays. Mr. Low indicates also the various causes of delay together with the time lost for these causes:

Item of Delay.	Total Hrs.	Total Min.	Item of Delay.	Total Hrs.	Total Min.
Hoist cables	24	55	Waiting for scows	29	54
Clam	101	40	Waiting for tugs	9	37
Main engines	4	55	Meals	125	40
Boilers	1	05	Rain and fog	4	15
Anchors and attachments	7	20	Sea	317	35
A frame and boom	6	15	Moving and placing	67	49
Breakdowns, dredge	0	35	Miscellaneous	36	26
Leaking scows	1	05	Holidays, etc	42	53
Repairing scows	14	51			
Siphoning scows	3	47	Total	800	35

Annual Expenses. In the annual expenses are included the interest of the capital invested in the plant, the sinking fund, insurance, taxes, profit of contractor, general expenses, etc.

The dredging plant required for any harbor or river improvement as a rule is very expensive, being composed of complicated and large machinery and numerous boats which necessitate the investment of a large capital. This capital if invested in any other way would certainly yield a profit, according to the conditions of the market, of 4 or 5 per cent per year. Consequently it cannot be said that the work performed by the machines has given a certain profit unless this interest has been deducted. In dredging, owing to the large capital invested in the plant, this interest charge is not likely to be overlooked, as when the plant is owned by private contractors, it is sometimes heavily mortgaged, and when owned by a public corporation, it has been acquired with money obtained from an issue of bonds, on which yearly interest must be paid. In any case the engineers should deduct from the gross profit the amount corresponding to at least 5 per cent of the total value of the plant on hand.

The life of any contractor's plant, especially one used for dredging, is comparatively short. Notwithstanding the continuous repairs which are made to the machine while at work, and the general overhauling which is usually given at the end of each working season, the machine depreciates continuously. The repairs increase from year to year, until a point is reached, when to keep the machine in working order, the expenditure required will be such as to justify the purchase of a new machine. From the yearly gross profits of the business a sinking fund should be set aside, so as to accumulate money to purchase a new dredge. In a word the same method must be used as for determining a sinking fund. It is difficult to determine the life of a dredge, since it could be extended by constant repairing for many years, but as a rule the life of the dredge is estimated to be from 15 to 20 years. At the end of this period, the machine, although greatly depreciated, will as junk still have a certain value, probably about 10 per cent of the original cost. The annuity or amount of money to be set aside from the gross profit of the undertaking should be such that at the end of 15 or 20 years will give an amount equal to nine-tenths of the original cost of the plant.

Another item of annual expense is the general overhauling

of the plant at the end of each working season. All the various machines should be looked over carefully and the parts that have been worn should be replaced. Gears, chains, ropes showing indication of weakness should be replaced with new ones. All the timber should be kept in first class order, well caulked and painted, and if the hulls of the dredge and boats are made of steel they should be cleaned, scraped and painted before being put in commission again. It is difficult to estimate accurately this item of expense, but when all the most important repairs have been made during the season and the plant has been kept in good working order, 10 per cent of the total cost of the plant should be sufficient to cover all the expenses required for the general overhauling.

The dredging plant should be insured against fire and maritime accidents. The annual premiums for carrying these two insurances are not heavy. Without more definite data, an amount equal to 2 or 3 per cent of the total value of the plant should be set aside for covering both the premiums of the fire and maritime insurance.

General expenses, as office rent, the renting of piers for mooring the dredges and tugboats during repairs and while not at work, the salaries of the engineers, superintendents, office clerks, all the taxes, office and traveling expenses should be deducted from the gross profits of the enterprise. In estimating without other data at hand, an amount varying between 5 and 15 per cent of the total amount of work done should cover general expenses. Five per cent of the total cost should be sufficient in case of large and extensive jobs, while for smaller ones, the general expenses should be estimated at 15 per cent of the total cost.

Another important item is the contractor's profit. He is entitled to a profit, not only for the time and knowledge given to the work, but also for the many risks that he runs. Ample compensation should be allowed him. It is difficult to state the percentage to allow for this item, but it is generally safe not to put it down for less than 10 or 15 per cent. This should be sufficient for large undertakings, but for smaller jobs a larger percentage must be allowed, and also for working in dangerous and exposed places.

CHAPTER XXIX

COST DATA

IN this chapter are given some examples illustrating the cost of dredging with different types of machines. They are taken from articles published in technical papers, and have been slightly condensed. The following examples are given in order:

1. The work of the ladder dredge "Percy Sanderson" used at Salina, mouth of the Danube River.
2. The cost of dredging with the hydraulic sea-going hopper dredges "Manhattan" and "Atlantic" as used in the Ambrose Channel, New York, and with the stationary hydraulic dredge used at Wilmington, Cal.
3. The cost of dredging with small dipper dredges used by U.S.A. engineers in the harbors and rivers of different parts of the country.
4. The cost of dredging with the clamshell dredge "Fin MacCool," used at Buffalo Breakwater, and described by Mr. Emile Low in Engineering News.

I

The cost of dredging with the sea-going hopper ladder dredge "Percy Sanderson," used at Salina, mouth of the Danube River, is taken from a paper by Mr. C. H. Kuhl, M. I. C. E., published in Engineering (London) December, 1901.

Regarding the cost the quality of the material to be dredged is the most important factor. A shallow cut on an uneven bottom naturally gives very unfavorable results. At Salina, the worst year was 1896, when the cost of dredging, transporting and discharging sand and silt was 5d. per cu.yd. The best year was 1899, when the cost with clay only came to 2.1d. per cu.yd. The average price is 4.2d. per cu.yd. for dredging 1,790,736 cu.yds. from 1894 to 1899, including all expenditure for repairs, renewals and liberal

maintenance of the dredger, but excluding interest, depreciation and insurance.

Dredge "Percy Sanderson" was built at a cost of £32,423, and dredged the following quantities from Salina entrance channel.

Dredging channel	{ between piers.....	201,655 cu.yds.		
	{ outside.....	786,062	"	
				987,717 cu.yds.
Maintenance from	{ between piers.....	224,028	"	
1895 to 1900	{ outside.....	796,395	"	1,020,423 "
Total.....				2,008,140 "

These quantities were excavated in the years and localities as indicated in the following table:

	Between the Piers.		At Sea.		Total.
	Old Ground.	New Ground.	Old Bank.	New Deposit.	
1894	Cubic Yards. 109,070	Cubic Yards.	Cubic Yards.	Cubic Yards.	109,070
1895	92,585	5,148	202,021	65,069	364,823
1896	101,241	16,398	155,426	273,065
1897	22,102	265,222	287,324
1898	14,259	143,306	188,259	325,824
1899	67,019	363,611	430,630
1900	14,259	60,726	142,419	217,404

NUMBER OF LOADS DREDGED AND REMOVED PER MONTH BY THE DREDGE "PERCY SANDERSON"

Month.	1894.	1895.	1896.	1897.	1898.	1899.	1900.
January.....	37	14			
February.....	40	3			
March.....	55	5	41			
April.....	32	12	39	18		
May.....	60	36	57	74		
June.....	64	40	49	79	110	
July.....	85	57	55	79	113	76
August.....	60	54	77	108	61
September.....	67	86	8	45	92	86
October.....	42	29	42	45	88	82
November.....	30	30	40	93	
December.....	59	21				
	131	529	383	403	457	604	305

DREDGE "PERCY SANDERSON." RECORD OF TIME WORKED AND QUANTITY DREDGED

Year.	Full Days.	Parts of Days.	Total Days.	Under Steam.		Actual Dredg- ing.		Total Quantity Dredged.	Quan- tity Dredg- ed per Work- ing Day.	Quan- tity Dredg- ed per Work- ing Hour.	Remarks.
				H.	M.	H.	M.				
1894	36	18	54	900	10	192	30	109,070	2020	567	Clay
1895	153	43	196	3546	20	1058	17	364,823	1861	345	Clay and sand
1896	129	34	163	3090	10	967	10	273,065	1675	282	Sand and silt
1897	126	41	170	2921	40	1113	45	289,324	1690	258	Sand and silt
1898	114	32	146	2401	20	917	35	325,824	2232	355	Clay and sand
1899	114	25	139	2271	50	843	45	430,630	3098	510	Clay
1900	67	25	92	1428	5	543	50	217,454	1823	308	Sand and silt

COST OF DREDGING, INCLUDING REPAIRS AND MAINTENANCE OF DREDGE

(Quantity dredged 1894-99, 1,790,736 cu.yds.)

			d.	d.
Dredging:	Coal and stores.....	0.81	}	2.05
	Crew and wages.....	1.24		
Repairs, etc.:	Coal and stores.....	1.02	}	2.17
	Crew and wages.....	1.15		

Total per cubic yard dredging and repairs..... 4.22

Interest, depreciation, and insurance not included.

The marine dredge "Percy Sanderson," built by Messrs. William Simons & Co. of Renfrew, is 220 ft. long, 40 ft. broad and 17 ft. 2 in. deep. The hopper carries 1250 tons. The 30 buckets have each a capacity of 21 cu.ft. and the machine can dredge to a depth of 35 ft. The dredge is propelled by two sets of triple-expansion surface-condensing engines of 1250 indicated horse-power combined, driving twin screws, and giving a speed of 8 knots when the vessel is fully loaded.

The dredge worked from sunrise to sunset; by preference only during the summer months, but also in winter when absolutely necessary.

When dredging in soft clay, six loads per day were generally dredged and discharged at a distance of three nautical miles. The daily time record being:

	Per Load.	
	Hrs.	Min.
Dredging.....	1	0
Transport.....	1	10
Mooring and unmooring.....	0	30
Six loads at 2 hours and 40 minutes.....	16	0
From and to anchorage.....	0	30
	—	—
	19	10

On one occasion seven loads were removed during one day of 17½ hours. The shortest time consumed in filling the hopper was 55 minutes. In dredging sand deposit in the channel, only four loads per day could be removed under favorable circumstances; the time record being:

	Per Load.	
	Hrs.	Min.
Dredging.....	2	0
Transport and discharge.....	1	10
Mooring and unmooring.....	0	30
Four loads at 3 hours 40 minutes.....	14	40
Dredger in and out of port.....	1	20
	<hr/>	<hr/>
	19	40

The success of dredging at sea depends principally upon the weather, though the "Percy Sanderson," being of great size, can work in a seaway up to 3 ft. high, when not on the beam.

II

Mr. Henry N. Babcock, M. Am. Soc. C. E., in Engineering News, Vol. LVI, described the work of the two hydraulic hopper dredges "Manhattan" and "Atlantic," used by the U. S. Government in the improvement of the Ambrose Channel, New York. Concerning the cost Mr. Babcock says:

"Before July 1, 1905, the dredges were undergoing considerable alterations and repairs to better adapt them to dredging the channel material. They had removed 467,450 cu.yds. of material in eight months' work of one dredge, and two months' of the other (total ten months) at a field cost of 9.9 cts. per yd., as nearly as data at hand show; some of the earlier bills were not paid from this office.

"From July 1, 1905, to May 31, 1906, eleven months' work for each dredge, they took out 3,258,707 cu.yds., at a field cost of 5.274 cts. per yd., the results from the two dredges being almost identical. This cost is divided up, in reference to different parts of the work done, as follows:

Pumping.....	3.357 cts.	= 63.66%
Turning.....	0.206	= 3.90
Going to dump.....	0.835	= 15.83
Dumping.....	0.223	= 4.22
Returning from dump.....	0.653	= 12.39
	<hr/>	<hr/>
	5.274 cts.	= 100%

“The getting of the material, pumping and turning, make almost exactly two-thirds the cost, and getting rid of it, the other one-third.

“Divided up according to different items of expenditure, it is:

Payroll.....	1.761	cts. = 33.39%
Coal.....	1.408	= 26.69
Water.....	0.039	= 00.75
Subsistence.....	0.476	= 9.02
Engine-room supplies.....	0.098	= 1.87
Miscellaneous supplies.....	0.150	= 2.84
Repairs and renewals.....	1.342	= 25.44

5.274 cts. = 100%

“These dredges are able sea boats and stay at work in Ambrose Channel in stormy weather, until it gets too rough to go to sea and dump, turning in the trough of the waves. They cannot work quite as fast in rough as in still weather, because the pipes have to be lifted more frequently to prevent the ship riding over them. When the weather gets too thick to see buoys and ranges work has to be suspended. But the chief cause of delays has been due to repairing.

“The following table gives the relative importance of the different causes of delay and lost time, being the record of two dredges working eleven months each, July 1, 1905, to May 31, 1906:

	Whole Days.	Parts of Days		Total in Days of 24 Hours	Percentage.
		Hrs.	Mins.		
Actually at work.....	8041	38	335.1	50.0
Repairing.....	112	628	05	138.1	20.6
Fog and snow.....	272	40	11.5	1.7
Storm.....	6	177	15	13.4	2.0
Taking on coal, etc., minor repairs, and clearing up parts of Saturdays and Mondays.....	1102	37	46.0	6.9
Miscellaneous.....	89	35	3.7	0.6
In July, 1905, before night work began.....	294	00	12.2	1.8
Sundays and holidays.....	110	110.0	16.4
				670.0	100

“The lost time due to repairs is the item which we are trying to reduce now. The value of this time far exceeds the cash cost of the repairs. During the last three months (March to May 31, 1906) each dredge has averaged 8908 cu.yds. of excavation per day

for every day on which it has worked at all. At 9 cts. per yd., the price paid for contract work in the same channel, this amounts to \$801 per day, and at this per diem valuation the value of time lost by reason of repairs in eleven months as above is \$110,538, while the money actually paid for these repairs was \$43,721.

ESTIMATES OF EXPENSES

"In September, 1905, a preliminary estimate was made of the total expenses which each dredge would have to meet and pay for out of the results of the work, if operated by a contractor. This estimate, \$12,500 per month, has proved so nearly accurate that no general revision of it has yet been made. It is as follows:

MONTHLY OPERATING EXPENSES

Payroll.....	\$2,660	
Coal.....	2,480	
Water.....	60	
Subsistence.....	700	
Engine-room supplies.....	150	
Other supplies.....	250	
Casual repairs.....	500	
Total per month.....		\$6,800

ANNUAL CARE OF PLANT

Docking and painting, twice a year.....	\$1,250	
Renewals of equipment.....	12,150	
Miscellaneous.....	1,000	
Total per year.....	\$14,400	
Average per month.....		1,200

ANNUAL FIXED CHARGES UPON ORIGINAL COST, ESTIMATED AT \$341,800

Sinking fund, toward original cost, 10%.....	\$34,180	
Interest, at 4%.....	13,672	
Insurance risk, 2%.....	6,836	
Fixed charges per year.....	\$54,688	
Average of fixed charges, per month.....		4,500
Total, per month.....		\$12,500

"The sinking fund is meant to cover depreciation. The insurance covers risk only, not what would be actual cost. For steel boats not going more than five miles from harbor, it probably more than covers any risk incurred. To meet these charges out of excavations which would otherwise be made under contract at 9 cts. per yd. requires an average output for each dredge of 138,900 cu. yds. per month—277,800

cu.yds. for the two dredges. Any excess over this, a contractor would apply to expenses of administration and to dividends.

“The twelve months ending June 30, 1906, show a monthly average, for the two dredges, of 316,200 yds.; the last three months' average is 458,319 yds.; in the last month, June, 1906, 535,692 yds. were excavated. The work of June, 1906, is the largest month's work which this plant has yet done. Under favorable conditions as to kind of material and with little lost time due to repairs, etc., it may perhaps be exceeded, but it is doubtful whether the plant can permanently maintain so high an average.”

COST OF HYDRAULIC DREDGING, HARBOR OF WILMINGTON, CAL.

In the harbor improvements at San Pedro and Wilmington, Cal. a suction dredge built by the Ellicott Machine Co., of Baltimore, Md., is employed. Prior to the acceptance of the same by the United States, and during an efficiency test, 16,450 cu.yds. of material were removed from the proposed harbor and deposited behind a bulkhead. The total cost for labor employed, including superintendence, and for the fuel, water and other supplies expended on account of this work, was \$1682.46, or at an average cost of 10.2 cents per cu.yd. of material handled. The dredge was placed in commission April 1, 1905, and between this date and June 30, 1905, it removed 227,464 cu.yds. of material, which consisted principally of sand intermingled with shell, and a small percentage of clay, cobbles, disintegrated sandstone and very compact and hard mud. During the period mentioned the dredge was laid up 16 days, May 15 to 30, 1905, so that the actual working time was 2½ months, the average rate of dredging per month being thus 91,000 cu.yds.

The following statement shows the cost of the dredging during the period from April 1 to June 30, 1905:

Routine office work, labor.....	\$673.33
Care of plant and property, labor.....	180.00
Surveys, labor and supplies.....	155.63
Towing and dispatch work, labor, fuel and supplies.....	316.00
Alterations and repairs to dredging plant, labor, and material.....	2,432.52
Operating dredge, including superintendence and labor charges, fuel, fresh water, lubricants, and all other supplies.....	10,084.54
Deterioration of plant and property, estimated.....	2,263.94
	<hr/>
	\$16,105.96

Cost per cubic yard, \$0.0708.

In addition to the hydraulic dredge, the following auxiliary floating plant is employed: A gasoline launch, length over all 30 ft. 1½ in., 7 ft. beam, depth 3 ft. 3 in., propelled by a 16 H.P. "standard" engine. Also 9 pontoons, each 35×10×3 ft.; 15 pontoons, each 21 ft. 3 in.×10×3 ft.; 1 water boat, 34 ft. 9 in.×10 ft.×4 ft. 6 in.; 1 oil boat, 34 ft. 9 in.×10 ft.×4 ft. 6 in.; 1 derrick boat, 29 ft. 6 in.×10 ft. 7 in.×3 ft. 10 in.

The original cost of the dredging plant was as follows:

20-inch suction dredge.....	\$99,453
Gasoline launch.....	1,733
Discharge pipe line for dredge.....	3,023
Rubber sleeves.....	1,275
Pontoons and barges.....	6,501
Skiffs.....	154

III

The following example illustrates the cost of dredging with dipper dredges of small capacity:

Capt. Frederick V. Abbot, Corps of Engineers, U. S. A., while in charge of the improvement of the harbor of Charleston, S. C., thus described the cost of the work of the dredge "Santee." The machine was built by the Osgood Dredge Co. of Albany, N. Y., with a boom 50 ft. long and the dipper of 1½ cu.yds. capacity.

"In regard to the cost of the work, I quote the following figures: Work began November 21, 1893.

November.....	5,572 cu.yds. mud,	7 stumps cost \$512.	Average 7 cts.
December.....	15,721 cu.yds. mud, 220	" " 690.	" 4
January.....	13,628 cu.yds. mud, 628	" " 456.	" 3
February.....	12,000 cu.yds. mud, 53	" " 945.	" 8
March.....	29,996 cu.yds. mud, 138	" " 470.	" 1½
April.....	14,313 cu.yds. mud,	" " 265.	" 2

"Work was suspended April 30, 1894. The total result of the work is as follows:

"Six thousand and seventy-five linear feet of canal have been completed between 50 and 60 ft. wide and between 6 and 7 ft. deep at low water, through the marsh, which is between 4 and 5 ft. above low-water level. The material consisted largely of exceedingly hard and sticky blue clay in which large cypress stumps were bedded.

"The material was harder than any I have encountered anywhere else in the district, and could not be handled at all by a clam-

shell machine. The total number of cubic yards excavated was 91,230, which included 793 stumps and three large logs. The average cost for the half year including all repairs and every expense properly chargeable to dredging, but making no allowance for depreciation of plant, is between 3 and 4 cts., or about one-tenth of the lowest contract price (.35½) that I have ever paid for work in this locality.

“The machine is now in thoroughly good order, and I see no reason why it could not run six months longer without any general overhauling.

“In soft material the capacity is fully 2000 yds. a day, and we have exceeded 1500 yds. on several occasions, when the proportion of stiff clay to the ordinary marsh mud was not excessive; the stumps seemed to offer no resistance to her work, as she generally pulled the bucket right up through them, splintering the solid wood so much that they would fall through the bucket. On one or two occasions when we unfortunately brought the whole stump out it stuck in the bucket and gave some trouble. The greater portion of the delay was caused by excessive stickiness of the clay, which would remain in the bucket sometimes several minutes after the bottom door was opened before it would fall through.”

The amount of work together with a detailed report of the supplies consumed during a month by the dipper dredge “Alpha,” of 1 cu.yd. capacity while working on the Raritan River was given by Mr. E. L. Sugram as follows:

“During the month of September, 1889, the U. S. Dredge ‘Alpha’ has been working in the Raritan River, making a 10-ft. channel out of a 7-ft. one. The material removed is light shale and gravel. The actual time worked was 207 hrs., and the amount dredged 12,050 cu.yds. The best day’s work was 750 cu.yds., and the worst 300 cu.yds. The machine is not worked very hard on account of an insufficient number of scows in the plant. The following supplies have been consumed during the month:

Line.....	350 lbs.
Lard oil.....	12½ gals.
Black oil.....	13 gals.
Cylinder oil.....	14½ gals.
Grease.....	119 lbs.
Cotton waste.....	8½ lbs.
Coal.....	41½ tons
Water.....	66,500 gals.
Kerosene.....	12½ gals.

"The cost for repairs has been almost nothing.

"The entire cost of running the whole plant, including interest on valuation, for the month of September last was approximately \$1400."

The work of the dipper dredge No. 4 of the Atlantic and Gulf Coast Canal and Okeechobee Land Co. is taken from the official report for the month of April, 1890. The machine was built by the Osgood Dredge Co., of Albany, N. Y.; the hull was 90×35×9 ft. with spuds 20×20 in. The boom was 50 ft. long and the dipper of 3½ cu.yds. capacity.

LOG OF DREDGE No. 4, FOR MONTH OF APRIL, 1890

Days worked (12 hours).....	21	Fuel, 62 cords wood.....	\$124.00
Number of crew.....	6	Payroll.....	239.66
Length of cut, in feet.....	2,747	Provisions.....	59.11
Width of cut, in feet (average).....	50	Supplies.....	33.49
Depth of cut, in feet (average).....	11	Repairs.....	46.17
Cubic yards dug in month....	55,957	Freight.....	13.02
Average per day.....	2,664	Incidentals.....	35.90
Maximum per day.....	3,809		
		Total cost for month....	\$551.35

Cost per cubic yard..... 0.99 of 1 cent.

Material: Cypress swamp, muck, and sand with rock at bottom of cut.

IV

The cost of deep-water dredging with a clamshell dredge for the Stony Point extension of the Buffalo, N. Y., Breakwater, was given by Mr. Emile Low, M. Am. Soc. C. E., in Engineering News, of October 11, 1906:

"It may be of interest to the profession to state the cost of the deep-water dredging with a very large clamshell dredge which was done some years ago on the Stony Point extension of the Buffalo, N.-Y., breakwater.

"The extension consists of two breakwaters, one 9989 ft. long and the other 2803 ft. long. The longer structure is made up of two parts, the rubble mound section (stone breakwater), 7250 ft. long, and the timber crib-section (South Harbor section), 2739 ft. long.

"The Stony Point timber-crib breakwater, with the exception of a few hundred feet next the shore, stands upon an artificial founda-

tion of sand and gravel, up to the level of the original lake bottom, this material having been back filled into a trench dredged practically to bed rock. At the outer end of the breakwater, where the water is over 22 ft. deep (also the maximum depth of the timber cribs), a rubble stone foundation is interposed between the bottom of the cribs and the top of the gravel filling.

“The South Harbor timber breakwater also stands upon a similar artificial foundation, with the exception that the rubble stone foundation is almost uniformly 8 ft. high, the cribs resting directly upon this.

“Under the original specifications contractors were permitted to use either hydraulic dredges or the clamshell type.

“The successful contractors, Hughes Bros. & Bangs, elected to excavate the trenches by means of a very large clamshell dredge, built expressly for this work by the Osgood Dredge Co., of Albany, N. Y.

“This dredge was illustrated and fully described in *Engineering News* of February 2, 1899, while it was engaged on the Buffalo works. It may be noted here that the clamshell bucket of this dredge has a capacity of 10 cu.yds. and weighed empty over 30,000 lbs. The hull of the dredge is 120 ft. long and 40 ft. broad., and a false stern increases the total length to 151 ft. The dredge had to excavate material from depths up to 70 ft., much of it solidly compacted. Most of the material dredged was a moderately stiff red clay, mixed with some blue clay. Overlying this clay was a layer of sand, perhaps one or two feet thick. Underlying the clay next to the rock was a layer of hard blue clay, mixed with broken stone or gravel, and in places there were a good many large boulders.

“The dredged material was generally transported to a dumping ground 10,000 ft. distant from the dredge, the time for the round trip being 1 hour and 6 minutes. Three steel scows were used to transport the excavated material.

“The principal cause of delay was the sea and wind (about three-eighths of the total delays). Considerable delay was also due to the clamshell bucket. Moving and placing the dredge was another large item of delay.

“Generally the dredge lay at anchor, in working position, throughout the week, and on Sundays was towed to shelter behind the completed Stony Point breakwater. This was also done during storms.

WORK DONE BY THE DREDGE "FIN MACCOOL" ON THE SOUTH HARBOR SECTION, BUFFALO, N. Y., BREAKWATER, DURING THE SEASON OF 1899

Month.	Time Worked h. m.	Time De-layed, h. m.	No. of Days.	Length of Day in Hours	No. of Scoops Loaded.	Average Load of Scoops, in Cubic Yards.	Average No. of Hours to Load to Scoop.	Material Dredged in Cubic Yards.	Cu.yds. per Hour Worked.	Average Hours Worked per Day.	Average Daily Delay in Hours Due to Sea.	Average No. of Yards per Day.	Max. Days' Work in Cubic Yards.	Max. Hour's Work in Cubic Yards.
May	190 37	131 23	23	14	166	322.2	1.1	53,494	280.6	8.3	2.7	2326	4621	369
June	232 11	131 49	26	14	191	335.2	1.2	54,292	275.7	8.9	2.8	2462	4318	346
July	211 40	152 20	26	14	180	306.3	1.2	55,138	260.0	8.1	1.6	2121	4001	364
August	255 31	122 29	27	14	217	358.7	1.2	71,848	304.7	9.5	1.6	2883	5037	438
September	133 12	206 48	24	{ 14 12	109	335.7	1.2	36,597	274.7	5.6	3.8	1525	3804	344
October	98 02	55 46	13	12	89	328.5	1.1	29,244	298.3	7.5	0.5	2250	3510	350
Total	1121 13	1800 35	139	..	952	332.3	1.18	316,343	282.1	8.0	2.3	2263	5037	438

Note. Abnormal time of one day's work, 14 hours.

DETAILED STATEMENT OF DELAYS ON CLAMSHELL DREDGE "FIN MACCOOL," SEASON OF 1899

Item of Delay.	May, h. m.		June, h. m.		July, h. m.		August, h. m.		September, h. m.		October, h. m.		Total, h. m.	
	h.	m.	h.	m.	h.	m.	h.	m.	h.	m.	h.	m.	h.	m.
Hoist cables	11	23	3	33	1	45	4	16	1	42	2	14	24	53
Clam	6	46	5	30	27	15	6	16	32	07	23	46	101	40
Main engines	2	20	1	20	0	20	0	55	4	55
Boilers	0	25	0	30	0	10
Anchors and attachments	0	25	0	30	0	10
A frame and boom
Breakdowns, dredge
Breakdowns, scows	0	20	..	0 35
Repairs, scows	1	46
Siphoning scows	0	20	6	..	5	43
Waiting for scows	4	08	0	40	9	01	0	45	0	54	..	0 35	14	51
Waiting for tugs	0	55	0	27	0	15	0	49	4	15	..	2 05	3	47
Meals	21	40	26	00	26	00	27	00	18	30	..	6 30	9	37
Rain and fog
Sea	61	10	73	03	42	47	3	00
Moving and placing	12	03	1	15	46	15	42	30
Miscellaneous	7	42	1	40	14	23	7	58
Holidays, etc.
Total	131	23	131	49	152	20	122	29	206	48	55	46	800	35

Later in the season, in the fall of the year, the dredge was towed to shelter behind the partially completed South Harbor breakwater every night.

"The daily routine of the dredge was as follows: Men rise at 4.30 A.M.; dredge begins work at 5; breakfast, 6 to 6.30; dinner 12 to 12.30 P.M.; supper after finishing work, at 7 P.M.

ESTIMATE OF COST OF DREDGING

"The cost of operations for the season, commencing with May 5, 1899, and ending October 16, 1899, is given below in detail.

"During this period 316,343 cu.yds. of material, scow measure, was dredged. The place measure was 286,335 cu.yds., showing an increase of 30,008 cu.yds. by scow measurement, or 10.48 per cent.

"The monthly expense of operating the dredge is shown below:

1 runner.....	\$90.00
1 second runner.....	35.00
1 fireman.....	35.00
1 deckhand.....	35.00
1 greaser.....	30.00
1 watchman.....	30.00
7 deckhands, at \$30.00.....	210.00
1 cook.....	30.00
1 cook's helper.....	15.00
	<hr/>
	\$510.00

"For working overtime the men received 15 cts. per hour; the runner 30 cts. per hour. The supplies for board cost \$12 per month per man.

"As the superintendent had charge of both the dredging and gravel filling, one-half his wages, or \$62.50 per month, is charged to dredging.

"The cost of the fuel was 52½ cts. for every 100 cu.yds. of material excavated.

"To keep the dredge and scows free from water, an old dredge was rigged up with a steam siphon, the cost of which per month was:

One man, per month.....	\$40.00
Coal, 20 tons, at \$1.50.....	30.00
	<hr/>
	\$70.00

“ Other expenses were as follows:

New cables (steel).....	\$100 per month
Oil, dope, waste, etc.....	20 “
Blacksmith shop.....	175 “
Lines, cables, etc. (hemp).....	40 “
Miscellaneous expenses.....	50 “
Yard expenses.....	100 “

“ Range piles and buoys cost \$256 for the season.

Small tugs, coaled.....	\$20 per day
Large tugs, coaled.....	25 “
Larger tugs, coaled.....	30 “

“ The assumed value of the plant is as follows:

Clamshell dredge, “Fin MacCool”.....	\$60,000
Steel dump scow, “Protective Policy”.....	12,000
Steel dump scow, “Gold Standard”.....	10,000
Steel dump scow, “Cuba Libre”.....	10,000
Total.....	\$92,000
Annual depreciation, 10%.....	9,200
Annual interest, 6%.....	5,520
Total.....	\$14,720

“ Total expenses for the season of 1899:

Superintendence.....	\$329.67
Wages.....	2,823.14
Board.....	980.34
Coal.....	1,660.80
Towing, tug hire.....	5,830.00
Siphoning.....	369.24
Cables, main, steel.....	527.49
Lines, ropes, etc., hemp.....	210.99
Blacksmith shop.....	923.11
Yard expenses.....	527.49
Miscellaneous expenses.....	263.74
Range piles and buoys.....	256.00
Total.....	\$14,702.01
Depreciation and interest.....	14,720.00
Total.....	\$29,422.01

Cubic yards excavated.....	316,343
Cost per cubic yard.....	$\frac{\$29,422.01}{316,343} = \$0.09^{20}/_{100}$
Operating expenses.....	$\frac{\$14,702.01}{316,343} = \$0.04^{64}/_{100}$
Depreciation and interest.....	$\frac{\$14,720.00}{316,343} = \$0.04^{65}/_{100}$

“The price paid the contractor was 18 cts. per cu.yd., amounting to \$56,941.74. Soon after the completion of this work this dredge was towed (in the fall of 1899) to Long Island Sound, via the Welland Canal and St. Lawrence River. After working here a short time, the dredge was transferred to the improvement of Bay Ridge and Red Hook Channels, New York Harbor, for which work Hughes Bros. & Bangs are the contractors.”

INDEX

- Agitators, 95
Allen's scraper, 96
American grab dredges, 168
American dumping scows, 193
Annual expenses, 258
Apjohn, James H., 96
Arnold, W. H., 181
Arnold clamshell bucket, 182
Austin drainage excavator, 247
Automatic devices for soundings, 1, 3
- Babeock, Henry N., 19, 263
Barges, 190
 deck, 192
 open-hold, 190
 steel-decked, 238
Bates, Lindon W., 99
Belt conveyor, 88, 185
Bishop conical screws, 143
Blasting:
 at Hell Gate, N. Y., 42
 at Henderson's Point, 46
 on the Erie harbor, 30
 on the Rhine River, 29
 on the Severn River, 29
Boilers, 80, 115, 123, 130, 163, 181
Boom, 163, 169
Buckets:
 Arnold for clamshell dredges, 182
 clamshell, 173
 of dipper dredge, 155
 elevator, 198
 for ladder dredges, 70
 for land excavation, 246
 orange-peel, 174
 for placer dredges, 220
- Caissons for rock excavation, 34
Centrifugal pump, 98
- Centrifugal pump lining, 99
 runner, 124
 shell, 98, 119, 129
Chutes, 71, 186, 200
Clamshell dredges, 62, 173
 "Champion," 181
 "Finn MacCool," 178
Clay and loam, 8
Comparison of methods of sounding, 13
Comparison of rockbreaking and blasting, 39
Compressed air for clamshell bucket, 181
Compressed air for dredging, 147
Conglomerate, 6
Contractors' profit, 259
Conveyor belt, 88, 185
Conveyor pipe, 100, 185
Cost of:
 blasting rock, 37-41
 operating dredges, 253
 dredging Ambrose Channel, 263
 deep dredging at Buffalo, 269
 dredging clamshell dredge, 269
 dredging harbor of Wilmington, Cal., 266
 dredging ladder dredges, 261-267
 dredging Salina Harbor, 261
 dredging on St. Lawrence River, 212
 gold dredging, 232
 hydraulic dredging, 263-266
 repairing, 209, 256
 rock blasting at Hell Gate, 46
 rock-breaking, 39
 rock excavation, 37
Coupling for discharge pipe, 150, 189
Crews, 56, 93, 210, 230, 272
Cutters, 96
 of Lobnitz machine, 25

- Deck barges, 192
- Deck scows, 191
- Delays in dredging, 256
- Diamond dredging, 217
- Dipper, 155
- Dipper dredges, 4, 61, 150
 - output of, 157
 - "Alpha," 158
 - "Chicago," 151-158
 - "Frontenac," 158
 - "Independent," 161
 - "Majestic," 164
- Dipper handle, 155
- Disintegrated rock, 6
- Ditcher:
 - Junkin's, 250
 - Mayer's, 251
 - Stephen's, 248
- Double-chain attachment for grab bucket, 176
- Double-ladder floating elevator, 201
- Drag, 207
- Drainage excavator, 247
- Dredge:
 - "Alpha," 158
 - "Baldwin," 207-213
 - "Cadiz," 83
 - "Caffrey," 142
 - "Champion," 181
 - "Chicago," 151-158
 - "City of Paris," 91
 - "City of Rouen," 116
 - "Delta," 123
 - "Essayon," 144
 - "Finn MacCool," 178
 - "Francis T. Simmons," 67
 - "Frontenac," 158
 - "Galveston," 67, 210
 - "Hunter," 228
 - "Independent," 161
 - "J. Israel Tarte," 67, 120, 208
 - "King Henry VII," 125
 - "Lady Aberdeen," 208
 - "Lady Minto," 213
 - "La Fontaine," 207, 213
 - "Laurier," 207, 213
 - "Laval," 213
- Dredge:
 - "Leviathan," 67
 - "Majestic," 164
 - "Marne," 84
 - "McAlester," 144
 - "Montana," 142
 - "Montevideo," 137
 - "Nereus," 107
 - "Pas-de-Calais," 79
 - "Percy Sanderson," 262
 - "St. Petersburg," 133
 - "Thomas," 114
 - "Ville de Rochefort," 75
- Dredges:
 - "Atlantic" and "Manhattan," 67, 263
 - clamshell, 62, 173, 178
 - dipper, 4, 61, 150
 - electric, 227
 - grapple, 62, 173
 - high-tower ladder, 89
 - hydraulic, 4, 51, 94, 234
 - ladder, 3, 52, 60, 219
 - non-propelling, 61
 - orange-peel bucket, 62, 174
 - pneumatic, 4, 61, 147
 - sea-going, 63, 74
 - self-propelling, 61, 85
 - semi-sea-going, 83
 - stirring, 4, 61, 140
 - universal, 132
- Dredging for:
 - diamond, 217
 - filling low lands, 240
 - gold, 218
 - industrial purposes, 233
 - metals, 217
 - platinum, 217
 - sand and gravel, 233
 - tin, 217
- Dredgmen, 56
- Drilling boat:
 - "Ingersoll," 33
 - "Rand," 34
 - used at Iron Gates, 32
 - at New York, 31
 - on the Rhine River, 35
- Dumping scows, 192
 - with sliding platform, 196

- Efficiency:
 of rockcutters, 23, 27
 pumps, 101
- Electric dredges, 227
- Elevator, double-ladder floating, 201
 floating, 200
- Elevator on land, 198
- Employment of dredges, 2
- Endless chain, 70
- Engines:
 for dipper dredges, 156, 162
 for grab dredges, 179
 hydraulic dredge, 114, 124, 128
 ladder dredge, 78, 82, 88, 92
 for spuds, 166
 of universal dredges, 134, 138
- English grab dredges, 169
- Expenses:
 annual, 258
 general, 259
 running, 254
- Exploding batteries, 35
- Explosives, 45, 48
- Estimating dredged materials, 16
- Fairbanks' walking dredge, 249
- Filling:
 for extending Governor's Island, N. Y., 243
 for improving Long Beach, L. I., 243
 marsh lands, 240
 tide water lands at Seattle, 241
- Floating clough, 141
- Floating elevator, 200
 with double ladder, 201
- Flood rock, Hell Gate, N. Y., 42
- Flow of débris through pipes, 71, 186
- Forward feeding hydraulic dredge, 104, 123
- Friction in pipes, 102
- Gaging the draft of scows, 16
- Gold dredging, 218
- Grab bucket:
 for clay, 173
 for gravel and boulder, 173
 for mud and silt, 173
- Grab bucket:
 for unloading barges, 202
- Grab dredges:
 American, 168
 double-line attachment, 176
 English, 169
 single-chain attachment, 175
 South American, 172
- Graduated rods for soundings, 12
- Grapple dredges, 62, 173
- Gravel, 7
 dredging, 236
- Hammering rocks, 22
- Handling of débris, 54
 sand, 237
- Hardpan, 8
- Harrow and scrapers, 141
- High-tower ladder dredges, 89
- Honeycombing the reef, 43
- Hopper dredge:
 "City of Rouen," 116
 "Montevideo," 137
 "Pas-de-Calais," 79
 "Percy Sanderson," 262
 "Thomas," 114
- Hopper for débris, 81, 106
- Hopper steamer, 195
- Hull of dredges, 68, 77, 85, 117, 126, 134, 151, 165, 179
- Hydraulic dredges, 4, 51, 94, 234
 "Atlantic" and "Manhattan," 67, 263
 forward feeding, 104, 123
 lateral feeding, 104, 120
 radial feeding, 104, 125
 sea-going, 110
 "City of Rouen," 116
 "Delta," 123
 "Galveston," 67, 210
 "J. Israel Tarte," 67, 120, 208
 "King Edward VII," 125
 "Leviathan," 67
 "Nereus," 107
 "Thomas," 114
- Hydraulic jets, 97
- Hydraulic survey, 14
- Hydro-pneumatic dredges, 148

- Increase of material, 18
 Industrial dredging, 233
 Ingersoll drilling boat, 33
 Insurance, 259
 Interest on capital, 258
- Jandin, M., 147
 Jets of compressed air, 149
 Jets of water, 97, 144
 Junkin's ditcher, 250
- Ladder dredges, 3, 52, 60, 219
 "Cadiz," 83
 "City of Paris," 91
 "Pas-de-Calais," 79
 "Percy Sanderson," 262
 "Ville de Rochefort," 75
 Land dredging, 246
 Lateral feeding hydraulic dredge, 104, 120
 Launches, 59
 Lead line for soundings, 12
 Lift holes, 46
 Light on dredges, 50
 Loam and clay, 8
 Lobnitz rock cutter, 24
- Mayer's ditching machine, 251
 Mann, L. M., 87
 McAlester, M. D., Maj. U. S. A., 144
 McDerby, George C., U. S. A., 42
 Measurement of quantities, 15
 by gaging the draft of scows, 16
 in place, 16
 by scows, 16
 Meyer, Cornelius, xi
 Mineral dredging, 217
 Mud or silt, 10, 187
- Newton, Gen. John, U. S. A., 42
 Non-propelling dredges, 61
- Ocherson, J. A., 141
 Open-hold barges, 190
 Operating expenses, 254
 Operations for hydraulic survey, 12
 Orange-peel bucket dredges, 62, 174
- Pardessus, R. M., 13
 Pipe:
 conveyors, 100, 185
 discharging, 100
 floating, 185
 suction, 95
- Placer dredge, 220
 with revolving screens, 222
 with shaking screens, 224
 with sluice-box, 225
- Place measurement, 16
 Platinum dredging, 217
 Pneumatic dredges, 4, 61, 147
 Pontoons, 191
 Profit of contractors, 259
 Propelling machines, 77, 82, 84, 109, 119, 171
 Propellers for stirring, 143
 Power for ladder dredge, 72
 Power required for pumps, 102
 Pump lining, 99
 Pump shell, 98, 119, 129
- Rackrock, 35
 Radial feeding hydraulic dredge, 104, 125
 Rand drilling boat, 34
 Revolving drums for stirring, 145
 Revolving screens, 222
 Revolving wheels for stirring, 143
 Ridgway belt conveyor, 88
 Robinson, A. W., 19, 64, 104
 Rock, 6
 disintegrated, 6
 dredging, 40
 Rock-cutter:
 Lobnitz, 24
 Scott & Godsir, 23
 Rock excavation:
 honeycombing the reef, 43
 lift holes, 46
 single large blast, 42
 Runner for centrifugal pump, 124
- Sand, 9, 186
 Sand and gravel dredging, 233
 Scrapers, 96, 144

- Screw-propelled tugboat, 198
 Scott & Godsir rock-cutter, 23
 Scow measurement, 16
 Sea-going dredges, 63, 74
 Sea-going hydraulic dredge, 105
 Sea-going steam-hopper, 195
 Selection of dredges, 50
 Self-propelling dredges, 61-85
 Semi-sea-going dredges, 83
 Shaking screens, 224
 Shrinkage of material, 18
 Side-wheeled tugboat, 198
 Silt or mud, 10, 187
 Sinking fund, 258
 Single-chain attachment for grab-buckets, 175
 Sluice boxes, 225
 Soils, 6
 clay and loam, 8
 disintegrated rock and conglomerate, 6
 hardpan, 8
 gravel, 7
 mud or silt, 10, 187
 rock, 6
 sand, 9, 186
 Soundings, 12
 automatic devices, 13
 graduated rods, 12
 lead line, 12
 Pardessus' method, 13
 South American grab dredge, 172
 Speed of pumps, 101
 Sprocket wheels for propulsion, 8
 Spuds, 85, 166, 179
 Stationary ladder dredges, 85
 Steam crane, 82, 135
 Steam punch, 24
 Steam hopper, 195
 Steamer:
 "Henry Burden," 110
 "Wiggins," 143
 Steel ram, 24
 Stephen's ditcher, 248
 Stirring:
 by harrow and scrapers, 141
 by propellers, 143
 by revolving drums, 145
 by revolving wheels, 143
 by water jets, 144
 Stirring dredges, 4, 61, 140
 "Caffrey," 142
 "Essayon," 144
 "McAlester," 144
 "Montana," 142
 Stone-lifters, 53
 Suction pipe, 95, 149
 connections, 95, 129
 Survey along a determined course, 15
 by three points, 14
 by triangulation, 14
 Tin dredging, 217
 Tower of ladder dredge, 70
 Transportation of débris, 4
 Tugboats, 58
 sidewheeled, 198
 screw-propelled, 198
 Tumbler, 69
 Universal dredges, 132
 "Montevideo," 137
 "St. Petersburg," 133
 Unloading barges by double-ladder floating elevator, 201
 by floating elevator, 200
 barges by grab bucket, 202
 barges by land elevator, 198
 débris from hoppers, 106
 machinery, 239
 sand, 239
 Veranteus, xi
 Wages, 210-230
 of crew on electric placer dredge, 230
 on a hydraulic dredge, 211
 on a ladder dredge, 210
 Walking dredge, 249
 Water jets, 97, 144
 Watt, James, xii
 Work of a ladder dredge at Fox River, Wis., 87
 dredges on St. Lawrence River, 204
 hydraulic dredges, 109-115

D. VAN NOSTRAND COMPANY

25 PARK PLACE

New York

SHORT-TITLE CATALOG

OF

Publications and Importations

OF

SCIENTIFIC AND ENGINEERING

BOOKS

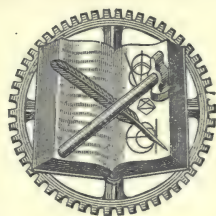

This list includes the technical publications of the following English publishers:

SCOTT, GREENWOOD & CO. CROSBY LOCKWOOD & SON
CONSTABLE & COMPANY, Ltd. TECHNICAL PUBLISHING CO.
ELECTRICIAN PRINTING & PUBLISHING CO.

for whom D. Van Nostrand Company are American agents.

AUGUST, 1912

SHORT-TITLE CATALOG

OF THE

Publications and Importations

OF

D. VAN NOSTRAND COMPANY

25 PARK PLACE, N. Y.

Prices marked with an asterisk () are NET.*

All bindings are in cloth unless otherwise noted.

A B C Code. (See Clausen-Thue.)

A1 Code. (See Clausen-Thue.)

Abbott, A. V. The Electrical Transmission of Energy.....	8vo,	*\$5 00
— A Treatise on Fuel. (Science Series No. 9.)..	16mo,	0 50
— Testing Machines. (Science Series No. 74.).....	16mo,	0 50
Adam, P. Practical Bookbinding. Trans. by T. E. Maw.....	12mo,	*2 50
Adams, H. Theory and Practice in Designing.....	8vo,	*2 50
Adams, H. C. Sewage of Sea Coast Towns.....	8vo	*2 00
Adams, J. W. Sewers and Drains for Populous Districts.....	8vo,	2 50
Addyman, F. T. Practical X-Ray Work.....	8vo,	*4 00
Adler, A. A. Principles of Projecting-line Drawing.....	8vo,	*1 00
— Theory of Engineering Drawing.....	8vo, (<i>In Press.</i>)	
Aikman, C. M. Manures and the Principles of Manuring.....	8vo,	2 50
Aitken, W. Manual of the Telephone.....	8vo,	*8 00
d'Albe, E. E. F., Contemporary Chemistry.....	12mo,	*1 25
Alexander, J. H. Elementary Electrical Engineering.....	12mo,	2 00
— Universal Dictionary of Weights and Measures.....	8vo,	3 50
"Alfred." Wireless Telegraph Designs.....		
Allan, W. Strength of Beams Under Transverse Loads. (Science Series No. 19.).....	16mo,	0 50
— Theory of Arches. (Science Series No. 11.).....	16mo,	
Allen, H. Modern Power Gas Producer Practice and Applications.....	12mo,	*2 50
— Gas and Oil Engines.....	8vo,	*4 50
Anderson, F. A. Boiler Feed Water.....	8vo,	*2 50
Anderson, Capt. G. L. Handbook for the Use of Electricians.....	8vo,	3 00
Anderson, J. W. Prospector's Handbook.....	12mo,	1 50
Andés, L. Vegetable Fats and Oils.....	8vo,	*4 00
— Animal Fats and Oils. Trans. by C. Salter.....	8vo,	*4 00
— Drying Oils, Boiled Oil, and Solid and Liquid Driers.....	8vo,	*5 00
— Iron Corrosion, Anti-fouling and Anti-corrosive Paints. Trans. by C. Salter.....	8vo,	*4 00

Andés, L. Oil Colors, and Printers' Ink. Trans. by A. Morris and H. Robson	8vo,	*2 50
— Treatment of Paper for Special Purposes. Trans. by C. Salter.	12mo,	*2 50
Andrews, E. S. Reinforced Concrete Construction.	12mo,	*1 25
Annual Reports on the Progress of Chemistry.		
Vol. I. (1904)	8vo,	*2 00
Vol. II. (1905)	8vo,	*2 00
Vol. III. (1906)	8vo,	*2 00
Vol. IV. (1907)	8vo,	*2 00
Vol. V. (1908)	8vo,	*2 00
Vol. VI. (1909)	8vo,	*2 00
Vol. VII. (1910)	8vo,	*2 00
Argand, M. Imaginary Quantities. Translated from the French by A. S. Hardy. (Science Series No. 52.)	16mo,	0 50
Armstrong, R., and Idell, F. E. Chimneys for Furnaces and Steam Boilers. (Science Series No. 1.)	16mo,	0 50
Arnold, E. Armature Windings of Direct-Current Dynamos. Trans. by F. B. DeGress	8vo,	*2 00
Ashe, S. W., and Keiley, J. D. Electric Railways. Theoretically and Practically Treated. Vol. I. Rolling Stock	12mo,	*2 50
Ashe, S. W. Electric Railways. Vol. II. Engineering Preliminaries and Direct Current Sub-Stations	12mo,	*2 50
— Electricity: Experimentally and Practically Applied	12mo,	*2 00
Atkinson, A. A. Electrical and Magnetic Calculations	8vo,	*1 50
Atkinson, J. J. Friction of Air in Mines. (Science Series No. 14.)	16mo,	0 50
Atkinson, J. J., and Williams, Jr., E. H. Gases Met with in Coal Mines. (Science Series No. 13.)	16mo,	0 50
Atkinson, P. The Elements of Electric Lighting	12mo,	1 50
— The Elements of Dynamic Electricity and Magnetism	12mo,	2 00
— Power Transmitted by Electricity	12mo,	2 00
Auchincloss, W. S. Link and Valve Motions Simplified	8vo,	*1 50
Ayrton, H. The Electric Arc	8vo,	*5 00
Bacon, F. W. Treatise on the Richards Steam-Engine Indicator	12mo,	1 00
Bailes, G. M. Modern Mining Practice. Five Volumes	8vo, each,	3 50
Bailey, R. D. The Brewers' Analyst	8vo,	*5 00
Baker, A. L. Quaternions	8vo,	*1 25
— Thick-Lens Optics	(In Press.,	
Baker, Benj. Pressure of Earthwork. (Science Series No. 56.)	16mo)	
Baker, I. O. Levelling. (Science Series No. 91.)	16mo,	0 50
Baker, M. N. Potable Water. (Science Series No. 61.)	16mo,	0 50
— Sewerage and Sewage Purification. (Science Series No. 18.)	16mo,	0 50
Baker, T. T. Telegraphic Transmission of Photographs	12mo,	*1 25
Bale, G. R. Modern Iron Foundry Practice. Two Volumes. 12mo.		
Vol. I. Foundry Equipment, Materials Used		*2 50
Vol. II. Machine Moulding and Moulding Machines		*1 50
Bale, M. P. Pumps and Pumping	12mo,	1 50
Ball, J. W. Concrete Structures in Railways. (In Press.)	8vo,	
Ball, R. S. Popular Guide to the Heavens	8vo,	*4 50
— Natural Sources of Power. (Westminster Series.)	8vo,	*2 00

Ball, W. V. Law Affecting Engineers.....	8vo,	*3 50
Bankson, Lloyd. Slide Valve Diagrams. (Science Series No. 108.)	16mo,	0 50
Barba, J. Use of Steel for Constructive Purposes.....	12mo,	1 00
Barham, G. B. Development of the Incandescent Electric Lamp.	(In Press.)	
Barker, A. Textiles and Their Manufacture. (Westminster Series.)	8vo,	2 00
Barker, A. H. Graphic Methods of Engine Design.....	12mo,	*1 50
Barnard, F. A. P. Report on Machinery and Processes of the Industrial Arts and Apparatus of the Exact Sciences at the Paris Universal Exposition, 1867.....	8vo,	5 00
Barnard, J. H. The Naval Militiaman's Guide.....	16mo, leather	1 25
Barnard, Major J. G. Rotary Motion. (Science Series No. 90.)	16mo,	0 50
Barrus, G. H. Boiler Tests.....	8vo,	*3 00
— Engine Tests.....	8vo,	*4 00
The above two purchased together.....		*6 00
Barwise, S. The Purification of Sewage.....	12mo,	3 50
Baterden, J. R. Timber. (Westminster Series.).....	8vo,	*2 00
Bates, E. L., and Charlesworth, F. Practical Mathematics.....	12mo,	
Part I. Preliminary and Elementary Course.....		*1 50
Part II. Advanced Course.....		*1 50
Beadle, C. Chapters on Papermaking. Five Volumes.....	12mo, each,	*2 00
Beaumont, R. Color in Woven Design.....	8vo,	*6 00
— Finishing of Textile Fabrics.....	8vo,	*4 00
Beaumont, W. W. The Steam-Engine Indicator.....	8vo,	2 50
Bechhold. Colloids in Biology and Medicine. Trans. by J. G. Bullowa (In Press.).....		
Beckwith, A. Pottery.....	8vo, paper,	0 60
Bedell, F., and Pierce, C. A. Direct and Alternating Current Manual.	8vo,	*2 00
Beech, F. Dyeing of Cotton Fabrics.....	8vo,	*3 00
— Dyeing of Woolen Fabrics.....	8vo,	*3 50
Begtrup, J. The Slide Valve.....	8vo,	*2 00
Beggs, G. E. Stresses in Railway Girders and Bridges.	(In Press.)	
Bender, C. E. Continuous Bridges. (Science Series No. 26.)	16mo,	0 50
— Proportions of Piers used in Bridges. (Science Series No. 4.)	16mo,	0 50
Bennett, H. G. The Manufacture of Leather.....	8vo,	*4 50
— Leather Trades (Outlines of Industrial Chemistry). 8vo. (In Press.)		
Bernthsen, A. A Text-book of Organic Chemistry. Trans. by G. M'Gowan.....	12mo,	*2 50
Berry, W. J. Differential Equations of the First Species. 12mo. (In Preparation.)		
Bersch, J. Manufacture of Mineral and Lake Pigments. Trans. by A. C. Wright.....	8vo,	*5 00
Bertin, L. E. Marine Boilers. Trans. by L. S. Robertson.....	8vo,	5 00
Beveridge, J. Papermaker's Pocket Book.....	12mo,	*4 00
Binns, C. F. Ceramic Technology.....	8vo,	*5 00
— Manual of Practical Potting.....	8vo,	*7 50
— The Potter's Craft.....	12mo,	*2 00
Birchmore, W. H. Interpretation of Gas Analysis.....	12mo,	*1 25
Blaine, R. G. The Calculus and Its Applications.....	12mo,	*1 50
Blake, W. H. Brewers' Vade Mecum.....	8vo,	*4 00
Blake, W. P. Report upon the Precious Metals.....	8vo,	2 00
Bligh, W. G. The Practical Design of Irrigation Works.....	8vo,	*6 00

Blücher, H. Modern Industrial Chemistry. Trans. by J. P. Millington	8vo,	*7 50
Blyth, A. W. Foods: Their Composition and Analysis.....	8vo,	7 50
— Poisons: Their Effects and Detection.....	8vo,	7 50
Böckmann, F. Celluloid.....	12mo,	*2 50
Bodmer, G. R. Hydraulic Motors and Turbines.....	12mo,	5 00
Boileau, J. T. Traverse Tables.....	8vo,	5 00
Bonney, G. E. The Electro-platers' Handbook.....	12mo,	1 20
Booth, N. Guide to the Ring-spinning Frame.....	12mo,	*1 25
Booth, W. H. Water Softening and Treatment.....	8vo,	*2 50
— Superheaters and Superheating and Their Control.....	8vo,	*1 50
Bottcher, A. Cranes: Their Construction, Mechanical Equipment and Working. Trans. by A. Tolhausen.....	4to,	*10 00
Bottler, M. Modern Bleaching Agents. Trans. by C. Salter.....	12mo,	*2 50
Bottone, S. R. Magnets for Automobilists.....	12mo,	*1 00
Boulton, S. B. Preservation of Timber. (Science Series No. 82.)	16mo,	0 50
Bourgougnon, A. Physical Problems. (Science Series No. 113.)	16mo,	0 50
Bourry, E. Treatise on Ceramic Industries. Trans. by J. J. Sudborough.	8vo,	*5 00
Bow, R. H. A Treatise on Bracing.....	8vo,	1 50
Bowie, A. J., Jr. A Practical Treatise on Hydraulic Mining.....	8vo,	5 00
Bowker, W. R. Dynamo, Motor and Switchboard Circuits.....	8vo,	*2 50
Bowles, O. Tables of Common Rocks. (Science Series No. 125.)	16mo,	0 50
Bowser, E. A. Elementary Treatise on Analytic Geometry.....	12mo,	1 75
— Elementary Treatise on the Differential and Integral Calculus.	12mo,	2 25
— Elementary Treatise on Analytic Mechanics.....	12mo,	3 00
— Elementary Treatise on Hydro-mechanics.....	12mo,	2 50
— A Treatise on Roofs and Bridges.....	12mo,	*2 25
Boycott, G. W. M. Compressed Air Work and Diving.....	8vo,	*4 00
Bragg, E. M. Marine Engine Design.....	12mo,	*2 00
Brainard, F. R. The Sextant. (Science Series No. 101.).....	16mo,	
Brassey's Naval Annual for 1911.....	8vo,	*6 00
Brew, W. Three-Phase Transmission.....	8vo,	*2 00
Brewer, R. W. A. Motor Car Construction.....	12mo,	
Briggs, R., and Wolff, A. R. Steam-Heating. (Science Series No. 67.).....	16mo,	0 50
Bright, C. The Life Story of Sir Charles Tilson Bright.....	8vo,	*4 50
Brislee, T. J. Introduction to the Study of Fuel. (Outlines of Industrial Chemistry).....	8vo,	*3 00
British Standard Sections.....	8x15	*1 00
Complete list of this series (45 parts) sent on application.		
Broadfoot, S. K. Motors, Secondary Batteries. (Installation Manuals Series).....	12mo,	*0 75
Broughton, H. H. Electric Cranes and Hoists.....		*9 00
Brown, G. Healthy Foundations. (Science Series No. 80.).....	16mo,	0 50
Brown, H. Irrigation.....	8vo,	*5 00
Brown, Wm. N. The Art of Enamelling on Metal.....	12mo,	*1 00
— Handbook on Japanning and Enamelling.....	12mo,	*1 50
— House Decorating and Painting.....	12mo,	*1 50
— History of Decorative Art.....	12mo,	*1 25
— Dipping, Burnishing, Lacquering and Bronzing Brass Ware.....	12mo,	*1 00

6 D. VAN NOSTRAND COMPANY'S SHORT TITLE CATALOG

Brown, Wm. N. Workshop Wrinkles.....	8vo,	*1 00
Browne, R. E. Water Meters. (Science Series No. 81.).....	16mo,	0 50
Bruce, E. M. Pure Food Tests.....	12mo,	*1 25
Bruhns, Dr. New Manual of Logarithms.....	8vo, half morocco,	2 00
Brunner, R. Manufacture of Lubricants, Shoe Polishes and Leather Dressings. Trans. by C. Salter.....	8vo,	*3 00
Buel, R. H. Safety Valves. (Science Series No. 21.).....	16mo,	0 50
Bulman, H. F., and Redmayne, R. S. A. Colliery Working and Management.....	8vo,	6 00
Burgh, N. P. Modern Marine Engineering.....	4to, half morocco,	10 00
Burstall, F. W. Energy Diagram for Gas. With Text.....	8vo,	1 50
—Diagram. Sold separately.....		*1 00
Burt, W. A. Key to the Solar Compass.....	16mo, leather,	2 50
Burton, F. G. Engineering Estimates and Cost Accounts.....	12mo,	*1 50
Buskett, E. W. Fire Assaying.....	12mo,	*1 25
Byers, H. G., and Knight, H. G. Notes on Qualitative Analysis....	8vo,	*1 50
Cain, W. Brief Course in the Calculus.....	12mo,	*1 75
— Elastic Arches. (Science Series No. 48.).....	16mo,	0 50
— Maximum Stresses. (Science Series No. 38.).....	16mo,	0 50
— Practical Designing Retaining of Walls. (Science Series No. 3.)	16mo,	0 50
— Theory of Steel-concrete Arches and of Vaulted Structures. (Science Series No. 42.).....	16mo,	0 50
— Theory of Voussoir Arches. (Science Series No. 12.).....	16mo,	0 50
— Symbolic Algebra. (Science Series No. 73.).....	16mo,	0 50
Campin, F. The Construction of Iron Roofs.....	8vo,	2 00
Carpenter, F. D. Geographical Surveying. (Science Series No. 37.).....	16mo,	
Carpenter, R. C., and Diederichs, H. Internal Combustion Engines.....	8vo,	*5 00
Carter, E. T. Motive Power and Gearing for Electrical Machinery ..	8vo,	*5 00
Carter, H. A. Ramie (Rhea), China Grass.....	12mo,	*2 00
Carter, H. R. Modern Flax, Hemp, and Jute Spinning.....	8vo,	*3 00
Cathcart, W. L. Machine Design. Part I. Fastenings.....	8vo,	*3 00
Cathcart, W. L., and Chaffee, J. I. Elements of Graphic Statics....	8vo,	*3 00
— Short Course in Graphics.....	12mo,	1 50
Caven, R. M., and Lander, G. D. Systematic Inorganic Chemistry.....	12mo,	*2 00
Chalkley, A. P. Diesel Engines.....	8vo,	*3 00
Chambers' Mathematical Tables.....	8vo,	1 75
Charnock, G. F. Workshop Practice. (Westminster Series.).....	8vo (In Press.)	
Charpentier, P. Timber.....	8vo,	*6 00
Chatley, H. Principles and Designs of Aeroplanes. (Science Series.)		
No. 126.).....	16mo,	0 50
— How to Use Water Power.....	12mo,	*1 00
Child, C. D. Electric Arc.....	8vo, *(In Press.)	
Child, C. T. The How and Why of Electricity.....	12mo,	1 00
Christie, W. W. Boiler-waters, Scale, Corrosion, Foaming.....	8vo,	*3 00
— Chimney Design and Theory.....	8vo,	*3 00
— Furnace Draft. (Science Series No. 123.).....	16mo,	0 50
— Water: Its Purification for Use in the Industries.....	8vo, (In Press.)	
Church's Laboratory Guide. Rewritten by Edward Kinch.....	8vo,	*2 50
Clapperton, G. Practical Papermaking.....	8vo,	2 50

Clark, A. G. Motor Car Engineering.		
Vol. I. Construction.....		*3 00
Vol. II. Design.....	(In Press.)	
Clark, C. H. Marine Gas Engines.....	12mo,	*1 50
Clark, D. K. Rules, Tables and Data for Mechanical Engineers....	8vo,	5 00
— Fuel: Its Combustion and Economy.....	12mo,	1 50
— The Mechanical Engineer's Pocketbook.....	16mo,	2 00
— Tramways: Their Construction and Working.....	8vo,	5 00
Clark, J. M. New System of Laying Out Railway Turnouts.....	12mo,	1 00
Clausen-Thue, W. A B C Telegraphic Code. Fourth Edition....	12mo,	*5 00
Fifth Edition.....	8vo,	*7 00
— The A 1 Telegraphic Code.....	8vo,	*7 50
Cleemann, T. M. The Railroad Engineer's Practice.....	12mo,	*1 50
Clerk, D., and Idell, F. E. Theory of the Gas Engine. (Science Series No. 62.).....	16mo,	0 50
Clevenger, S. R. Treatise on the Method of Government Surveying. 16mo, morocco.....		2 50
Clouth, F. Rubber, Gutta-Percha, and Balata.....	8vo,	*5 00
Cochran, J. Treatise on Cement Specifications....	8vo, (In Press.)	
Coffin, J. H. C. Navigation and Nautical Astronomy.....	12mo,	*3 50
Colburn, Z., and Thurston, R. H. Steam Boiler Explosions. (Science Series No. 2.).....	16mo,	0 50
Cole, R. S. Treatise on Photographic Optics.....	12mo,	1 50
Coles-Finch, W. Water, Its Origin and Use.....	8vo,	*5 00
Collins, J. E. Useful Alloys and Memoranda for Goldsmiths, Jewelers. 16mo.....		0 50
Constantine, E. Marine Engineers, Their Qualifications and Duties. 8vo,		*2 00
Coombs, H. A. Gear Teeth. (Science Series No. 120.).....	16mo,	0 50
Cooper, W. R. Primary Batteries.....	8vo,	*4 00
— "The Electrician" Primers.....	8vo,	*5 00
Part I.....		*1 50
Part II.....		*2 50
Part III.....		*2 00
Copperthwaite, W. C. Tunnel Shields.....	4to,	*9 00
Corey, H. T. Water Supply Engineering.....	8vo (In Press.)	
Corfield, W. H. Dwelling Houses. (Science Series No. 50.).....	16mo,	0 50
— Water and Water-Supply. (Science Series No. 17.).....	16mo,	0 50
Cornwall, H. B. Manual of Blow-pipe Analysis.....	8vo,	*2 50
Courtney, C. F. Masonry Dams.....	8vo,	3 50
Cowell, W. B. Pure Air, Ozone, and Water.....	12mo,	*2 00
Craig, T. Motion of a Solid in a Fuel. (Science Series No. 49.)....	16mo,	0 50
— Wave and Vortex Motion. (Science Series No. 43.).....	16mo,	0 50
Cramp, W. Continuous Current Machine Design.....	8vo,	*2 50
Crocker, F. B. Electric Lighting. Two Volumes. 8vo.		
Vol. I. The Generating Plant.....		3 00
Vol. II. Distributing Systems and Lamps.....		3 00
Crocker, F. B., and Arendt, M. Electric Motors.....	8vo,	*2 50
Crocker, F. B., and Wheeler, S. S. The Management of Electrical Machinery.....	12mo,	*1 00
Cross, C. F., Bevan, E. J., and Sindall, R. W. Wood Pulp and Its Applications. (Westminster Series.).....	8vo,	*2 00

Crosskey, L. R. Elementary Perspective.....	8vo,	1 00
Crosskey, L. R., and Thaw, J. Advanced Perspective.....	8vo,	1 50
Culley, J. L. Theory of Arches. (Science Series No. 87.).....	16mo,	0 50
Davenport, C. The Book. (Westminster Series.).....	8vo,	*2 00
Davies, D. C. Metalliferous Minerals and Mining.....	8vo,	5 00
— Earthy Minerals and Mining.....	8vo,	5 00
Davies, E. H. Machinery for Metalliferous Mines.....	8vo,	8 00
Davies, F. H. Electric Power and Traction.....	8vo,	*2 00
Dawson, P. Electric Traction on Railways.....	8vo,	*9 00
Day, C. The Indicator and Its Diagrams.....	12mo,	*2 00
Deerr, N. Sugar and the Sugar Cane.....	8vo,	*8 00
Deite, C. Manual of Soapmaking. Trans. by S. T. King.....	4to,	*5 00
De la Coux, H. The Industrial Uses of Water. Trans. by A. Morris.	8vo,	*4 50
Del Mar, W. A. Electric Power Conductors.....	8vo,	*2 00
Denny, G. A. Deep-level Mines of the Rand.....	4to,	*10 00
— Diamond Drilling for Gold.....		*5 00
De Roos, J. D. C. Linkages. (Science Series No. 47.).....	16mo,	0 50
Derr, W. L. Block Signal Operation.....	Oblong 12mo,	*1 50
— Maintenance-of-Way Engineering.....	(In Preparation.)	
Desaint, A. Three Hundred Shades and How to Mix Them.....	8vo,	*10 00
De Varona, A. Sewer Gases. (Science Series No. 55.).....	16mo,	0 50
Devey, R. G. Mill and Factory Wiring. (Installation Manuals Series.)	12mo,	*1 00
Dibdin, W. J. Public Lighting by Gas and Electricity.....	8vo,	*8 00
— Purification of Sewage and Water.....	8vo,	6 50
Dichmann, Carl. Basic Open-Hearth Steel Process.....	12mo,	*3 50
Dieterich, K. Analysis of Resins, Balsams, and Gum Resins.....	8vo,	*3 00
Dinger, Lieut. H. C. Care and Operation of Naval Machinery.....	12mo,	*2 00
Dixon, D. B. Machinist's and Steam Engineer's Practical Calculator.	16mo, morocco,	1 25
Doble, W. A. Power Plant Construction on the Pacific Coast (In Press.)		
Dodd, G. Dictionary of Manufactures, Mining, Machinery, and the Industrial Arts.....	12mo,	1 50
Dorr, B. F. The Surveyor's Guide and Pocket Table-book.	16mo, morocco,	2 00
Down, P. B. Handy Copper Wire Table.....	16mo,	*1 00
Draper, C. H. Elementary Text-book of Light, Heat and Sound.....	12mo,	1 00
— Heat and the Principles of Thermo-dynamics.....	12mo,	1 50
Duckwall, E. W. Canning and Preserving of Food Products.....	8vo,	*5 00
Dumesny, P., and Noyer, J. Wood Products, Distillates, and Extracts.	8vo,	*4 50
Duncan, W. G., and Penman, D. The Electrical Equipment of Collieries.	8vo,	*4 00
Dunstan, A. E., and Thole, F. B. T. Textbook of Practical Chemistry.	12mo,	*1 40
Duthie, A. L. Decorative Glass Processes. (Westminster Series.).....	8vo,	*2 00
Dwight, H. B. Transmission Line Formulas.....	8vo, (In Press.)	
Dyson, S. S. Practical Testing of Raw Materials.....	8vo,	*5 00
Dyson, S. S., and Clarkson, S. S. Chemical Works.....	8vo,	*7 50

Eccles, R. G., and Duckwall, E. W. Food Preservatives.	8vo, paper	0 50
Eddy, H. T. Researches in Graphical Statics.	8vo,	1 50
— Maximum Stresses under Concentrated Loads.	8vo,	1 50
Edgcombe, K. Industrial Electrical Measuring Instruments.	8vo,	*2 50
Eissler, M. The Metallurgy of Gold.	8vo.	7 50
— The Hydrometallurgy of Copper.	8vo,	*4 50
— The Metallurgy of Silver.	8vo,	4 00
— The Metallurgy of Argentiferous Lead.	8vo,	5 00
— Cyanide Process for the Extraction of Gold.	8vo,	3 00
— A Handbook on Modern Explosives.	8vo,	5 00
Ekin, T. C. Water Pipe and Sewage Discharge Diagrams.	folio,	*3 00
Eliot, C. W., and Storer, F. H. Compendious Manual of Qualitative Chemical Analysis.	12mo,	*1 25
Elliot, Major G. H. European Light-house Systems.	8vo,	5 00
Ennis, Wm. D. Linseed Oil and Other Seed Oils.	8vo,	*4 00
— Applied Thermodynamics.	8vo	*4 50
— Flying Machines To-day.	12mo,	*1 50
— Vapors for Heat Engines.	12mo,	*1 00
Erfurt, J. Dyeing of Paper Pulp. Trans. by J. Hubner.	8vo,	*7 50
Erskine-Murray, J. A Handbook of Wireless Telegraphy.	8vo,	*3 50
Evans, C. A. Macadamized Roads.	(In Press.)	
Ewing, A. J. Magnetic Induction in Iron.	8vo,	*4 00
Fairie, J. Notes on Lead Ores.	12mo,	*1 00
— Notes on Pottery Clays.	12mo,	*1 50
Fairley, W., and Andre, Geo. J. Ventilation of Coal Mines. (Science Series No. 58.)	16mo,	0 50
Fairweather, W. C. Foreign and Colonial Patent Laws.	8vo,	*3 00
Fanning, J. T. Hydraulic and Water-supply Engineering.	8vo,	*5 00
Fauth, P. The Moon in Modern Astronomy. Trans. by J. McCabe. 8vo,		*2 00
Fay, I. W. The Coal-tar Colors.	8vo,	*4 00
Fernbach, R. L. Glue and Gelatine.	8vo,	*3 00
— Chemical Aspects of Silk Manufacture.	12mo,	*1 00
Fischer, E. The Preparation of Organic Compounds. Trans. by R. V. Stanford.	12mo,	*1 25
Fish, J. C. L. Lettering of Working Drawings	Oblong 8vo,	1 00
Fisher, H. K. C., and Darby, W. C. Submarine Cable Testing.	8vo,	*3 50
Fiske, Lieut. B. A. Electricity in Theory and Practice.	8vo,	2 50
Fleischmann, W. The Book of the Dairy. Trans. by C. M. Aikman. 8vo,		4 00
Fleming, J. A. The Alternate-current Transformer. Two Volumes. 8vo. Vol. I. The Induction of Electric Currents.		*5 00
Vol. II. The Utilization of Induced Currents.		*5 00
— Propagation of Electric Currents.	8vo,	*3 00
— Centenary of the Electrical Current.	8vo,	*0 50
— Electric Lamps and Electric Lighting.	8vo,	*3 00
— Electrical Laboratory Notes and Forms.	4to,	*5 00
— A Handbook for the Electrical Laboratory and Testing Room. Two Volumes	8vo, each,	*5 00
Fluery, H. The Calculus Without Limits or Infinitesimals. Trans. by C. O. Mailloux.	(In Press.)	

10 D. VAN NOSTRAND COMPANY'S SHORT TITLE CATALOG

Rynn, P. J. Flow of Water. (Science Series No. 84.)	16mo,	0 50
— Hydraulic Tables. (Science Series No. 66.)	16mo,	0 50
Foley, N. British and American Customary and Metric Measures. folio,		*3 00
Foster, H. A. Electrical Engineers' Pocket-book. (Sixth Edition.)	12mo, leather,	5 00
— Engineering Valuation of Public Utilities and Factories	8vo,	*3 00
Foster, Gen. J. G. Submarine Blasting in Boston (Mass.) Harbor.	4to,	3 50
Fowle, F. F. Overhead Transmission Line Crossings.	12mo,	*1 50
— The Solution of Alternating Current Problems. (In Press.)	8vo	
Fox, W. G. Transition Curves. (Science Series No. 110.)	16mo,	0 50
Fox, W., and Thomas, C. W. Practical Course in Mechanical Drawing.	12mo,	1 25
Foye, J. C. Chemical Problems. (Science Series No. 69.)	16mo,	0 50
— Handbook of Mineralogy. (Science Series No. 86.)	16mo,	0 50
Francis, J. B. Lowell Hydraulic Experiments.	4to,	15 00
Freudemacher, P. W. Electrical Mining Installations. (Installation Manuals Series.)	12mo,	*1 00
Frith, J. Alternating Current Design.	8vo,	*2 00
Fritsch, J. Manufacture of Chemical Manures. Trans. by D. Grant.	8vo,	*4 00
Frye, A. I. Civil Engineers' Pocket-book.	12mo, leather,	
Fuller, G. W. Investigations into the Purification of the Ohio River.	4to.	*10 00
Furnell, J. Paints, Colors, Oils, and Varnishes.	8vo,	*1 00
Gairdner, J. W. I. Earthwork.	8vo, (In Press.)	
Gant, L. W. Elements of Electric Traction.	8vo,	*2 50
Garforth, W. E. Rules for Recovering Coal Mines after Explosions and Fires.	12mo, leather,	1 50
Gaudard, J. Foundations. (Science Series No. 34.)	16mo,	0 50
Gear, H. B., and Williams, P. F. Electric Central Station Distribution Systems.	8vo,	*3 00
Geerlign, H. C. P. Cane Sugar and Its Manufacture.	8vo,	*5 00
Geikie, J. Structural and Field Geology.	8vo,	*4 00
Gerber, N. Analysis of Milk, Condensed Milk, and Infants' Milk-Food.	8vo,	1 25
Gerhard, W. P. Sanitation, Watersupply and Sewage Disposal of Country Houses.	12mo,	*2 00
— Gas Lighting. (Science Series No. 111.)	16mo,	0 50
— Household Wastes. (Science Series No. 97.)	16mo,	0 50
— House Drainage. (Science Series No. 63.)	16mo,	0 50
— Sanitary Drainage of Buildings. (Science Series No. 93.)	16mo,	0 50
Gerhardi, C. W. H. Electricity Meters.	8vo,	*4 00
Geschwind, L. Manufacture of Alum and Sulphates. Trans. by C. Salter.	8vo,	*5 00
Gibbs, W. E. Lighting by Acetylene.	12mo,	*1 50
— Physics of Solids and Fluids. (Carnegie Technical School's Text- books.)		*1 50
Gibson, A. H. Hydraulics and Its Application.	8vo,	*5 00
— Water Hammer in Hydraulic Pipe Lines.	12mo,	*2 00
Gilbreth, F. B. Motion Study.	12mo,	*2 00
— Primer of Scientific Management.	12mo,	*1 00

Gillmore, Gen. Q. A. Limes, Hydraulic Cements and Mortars	8vo,	4 00
— Roads, Streets, and Pavements	12mo,	2 00
Golding, H. A. The Theta-Phi Diagram	12mo,	*1 25
Goldschmidt, R. Alternating Current Commutator Motor	8vo,	*3 00
Goodchild, W. Precious Stones. (Westminster Series.)	8vo,	*2 00
Goodeve, T. M. Textbook on the Steam-engine	12mo,	2 00
Gore, G. Electrolytic Separation of Metals	8vo,	*3 50
Gould, E. S. Arithmetic of the Steam-engine	12mo,	1 00
— Calculus. (Science Series No. 112.)	16mo,	0 50
— High Masonry Dams. (Science Series No. 22.)	16mo,	0 50
— Practical Hydrostatics and Hydrostatic Formulas. (Science Series No. 117.)	16mo,	0 50
Grant, J. Brewing and Distilling. (Westminster Series.) 8vo (<i>In Press.</i>)		
Gratacap, L. P. A Popular Guide to Minerals.	8vo (<i>In Press.</i>)	
Gray, J. Electrical Influence Machines	12mo,	2 00
— Marine Boiler Design	12mo, (<i>In Press.</i>)	
Greenhill, G. Dynamics of Mechanical Flight	8vo, (<i>In Press.</i>)	
Greenwood, E. Classified Guide to Technical and Commercial Books. 8vo,		*3 00
Gregorius, R. Mineral Waxes. Trans. by C. Salter	12mo,	*3 00
Griffiths, A. B. A Treatise on Manures	12mo,	3 00
— Dental Metallurgy	8vo,	*3 50
Gross, E. Hops	8vo,	*4 50
Grossman, J. Ammonia and Its Compounds	12mo,	*1 25
Groth, L. A. Welding and Cutting Metals by Gases or Electricity	8vo,	*3 00
Grover, F. Modern Gas and Oil Engines	8vo,	*2 00
Gruner, A. Power-loom Weaving	8vo,	*3 00
Guldner, Hugo. Internal Combustion Engines. Trans. by H. Diederichs. 4to,		*10 00
Gunther, C. O. Integration	12mo,	*1 25
Gurden, R. L. Traverse Tables	folio, half morocco,	*7 50
Guy, A. E. Experiments on the Flexure of Beams	8vo,	*1 25
Haeder, H. Handbook on the Steam-engine. Trans. by H. H. P. Powles	12mo,	3 00
Hainbach, R. Pottery Decoration. Trans. by C. Slater	12mo,	*3 00
Haenig, A. Emery and Emery Industry	8vo, (<i>In Press.</i>)	
Hale, W. J. Calculations of General Chemistry	12mo,	*1 00
Hall, C. H. Chemistry of Paints and Paint Vehicles	12mo,	*2 00
Hall, R. H. Governors and Governing Mechanism	12mo,	*2 00
Hall, W. S. Elements of the Differential and Integral Calculus	8vo,	*2 25
— Descriptive Geometry	8vo volume and a 4to atlas,	*3 50
Haller, G. F., and Cunningham, E. T. The Tesla Coil	12mo,	*1 25
Halsey, F. A. Slide Valve Gears	12mo,	1 50
— The Use of the Slide Rule. (Science Series No. 114.)	16mo,	0 50
— Worm and Spiral Gearing. (Science Series No. 116.)	16mo,	0 50
Hamilton, W. G. Useful Information for Railway Men	16mo,	1 00
Hammer, W. J. Radium and Other Radio-active Substances	8vo,	*1 00
Hancock, H. Textbook of Mechanics and Hydrostatics	8vo,	1 50
Hardy, E. Elementary Principles of Graphic Statics	12mo,	*1 50
Harrison, W. B. The Mechanics' Tool-book	12mo,	1 50
Hart, J. W. External Plumbing Work	8vo,	*3 00

Hart, J. W. Hints to Plumbers on Joint Wiping	8vo,	*3 00
— Principles of Hot Water Supply	8vo,	*3 00
— Sanitary Plumbing and Drainage	8vo,	*3 00
Haskins, C. H. The Galvanometer and Its Uses	16mo,	1 50
Hatt, J. A. H. The Colorist	square 12mo,	*1 50
Hausbrand, E. Drying by Means of Air and Steam. Trans. by A. C. Wright	12mo,	*2 00
— Evaporating, Condensing and Cooling Apparatus. Trans. by A. C. Wright	8vo,	*5 00
Hausner, A. Manufacture of Preserved Foods and Sweetmeats. Trans. by A. Morris and H. Robson	8vo,	*3 00
Hawke, W. H. Premier Cipher Telegraphic Code	4to,	*5 00
— 100,000 Words Supplement to the Premier Code	4to,	*5 00
Hawkesworth, J. Graphical Handbook for Reinforced Concrete Design.	4to,	*2 50
Hay, A. Alternating Currents	8vo,	*2 50
— Electrical Distributing Networks and Distributing Lines	8vo,	*3 50
— Continuous Current Engineering	8vo,	*2 50
Heap, Major D. P. Electrical Appliances	8vo,	2 00
Heaviside, O. Electromagnetic Theory. Two Volumes	8vo, each,	*5 00
Heck, R. C. H. The Steam Engine and Turbine	8vo,	*5 00
— Steam-Engine and Other Steam Motors. Two Volumes.		
Vol. I. Thermodynamics and the Mechanics	8vo,	*3 50
Vol. II. Form, Construction, and Working	8vo,	*5 00
— Notes on Elementary Kinematics	8vo, boards,	*1 00
— Graphics of Machine Forces	8vo, boards,	*1 00
Hedges, K. Modern Lightning Conductors	8vo,	3 00
Heermann, P. Dyers' Materials. Trans. by A. C. Wright	12mo,	*2 50
Hellot, Macquer and D'Apligny. Art of Dyeing Wool, Silk and Cotton.	8vo,	*2 00
Henrici, O. Skeleton Structures	8vo,	1 50
Hering, D. W. Essentials of Physics for College Students	8vo,	*1 60
Hering-Shaw, A. Domestic Sanitation and Plumbing. Two Vols.	8vo,	*5 00
— Elementary Science	8vo,	*2 00
Herrmann, G. The Graphical Statics of Mechanism. Trans. by A. P. Smith	12mo,	2 00
Herzfeld, J. Testing of Yarns and Textile Fabrics	8vo,	*3 50
Hildebrandt, A. Airships, Past and Present	8vo,	*3 50
Hildenbrand, B. W. Cable-Making. (Science Series No. 32.)	16mo,	0 50
Hilditch, T. P. A Concise History of Chemistry	12mo,	*1 25
Hill, J. W. The Purification of Public Water Supplies. New Edition.		
	(In Press.)	
— Interpretation of Water Analysis	(In Press.)	
Hiroi, I. Plate Girder Construction. (Science Series No. 95.)	16mo,	0 50
— Statically-Indeterminate Stresses	12mo,	*2 00
Hirshfeld, C. F. Engineering Thermodynamics. (Science Series No. 45.)	16mo,	0 50
Hobart, H. M. Heavy Electrical Engineering	8vo,	*4 50
— Design of Static Transformers	12mo,	*2 00
— Electricity	8vo,	*2 00
— Electric Trains	8vo,	*2 50

Hobart, H. M. Electric Propulsion of Ships.....	8vo,	*2 00
Hobart, J. F. Hard Soldering, Soft Soldering and Brazing.....	12mo,	
	(In Press.)	
Hobbs, W. R. P. The Arithmetic of Electrical Measurements.....	12mo,	0 50
Hoff, J. N. Paint and Varnish Facts and Formulas.....	12mo,	*1 50
Hoff, Com. W. B. The Avoidance of Collisions at Sea.....	16mo, morocco,	0 75
Hole, W. The Distribution of Gas.....	8vo,	*7 50
Holley, A. L. Railway Practice.....	folio,	12 00
Holmes, A. B. The Electric Light Popularly Explained.....	12mo, paper,	0 50
Hopkins, N. M. Experimental Electrochemistry.....	8vo,	*3 00
— Model Engines and Small Boats.....	12mo,	1 25
Hopkinson, J. Shoolbred, J. N., and Day, R. E. Dynamic Electricity. (Science Series No. 71.).....	16mo,	0 50
Horner, J. Engineers' Turning.....	8vo,	*3 50
— Metal Turning.....	12mo,	1 50
— Toothed Gearing.....	12mo,	2 25
Houghton, C. E. The Elements of Mechanics of Materials.....	12mo,	*2 00
Houllevigue, L. The Evolution of the Sciences.....	8vo,	*2 00
Howe, G. Mathematics for the Practical Man.....	12mo,	*1 25
Howorth, J. Repairing and Riveting Glass, China and Earthenware. 8vo, paper,		*0 50
Hubbard, E. The Utilization of Wood-waste.....	8vo,	*2 50
Hübner, J. Bleaching and Dyeing of Vegetable and Fibrous Materials (Outlines of Industrial Chemistry).....	8vo, (In Press.)	
Hudson, O. F. Iron and Steel. (Outlines of Industrial Chemistry.) 8vo, (In Press.)		
Humper, W. Calculation of Strains in Girders.....	12mo,	2 50
Humphreys, A. C. The Business Features of Engineering Practice.....	8vo,	*1 25
Hunter, A. Bridge Work.....	8vo, (In Press.)	
Hurst, G. H. Handbook of the Theory of Color.....	8vo,	*2 50
— Dictionary of Chemicals and Raw Products.....	8vo,	*3 00
— Lubricating Oils, Fats and Greases.....	8vo,	*4 00
— Soaps.....	8vo,	*5 00
— Textile Soaps and Oils.....	8vo,	*2 50
Hurst, H. E., and Lattey, R. T. Text-book of Physics.....	8vo,	*3 00
Hutchinson, R. W., Jr. Long Distance Electric Power Transmission. 12mo,		*3 00
Hutchinson, R. W., Jr., and Ihseng, M. C. Electricity in Mining.....	12mo,	
	(In Press)	
Hutchinson, W. B. Patents and How to Make Money Out of Them.....	12mo,	1 25
Hutton, W. S. Steam-boiler Construction.....	8vo,	6 00
— Practical Engineer's Handbook.....	8vo,	7 00
— The Works' Manager's Handbook.....	8vo,	6 00
Hyde, E. W. Skew Arches. (Science Series No. 15.).....	16mo,	0 50
Induction Coils. (Science Series No. 53.).....	16mo,	0 50
Ingle, H. Manual of Agricultural Chemistry.....	8vo,	*3 00
Innes, C. H. Problems in Machine Design.....	12mo,	*2 00
— Air Compressors and Blowing Engines.....	12mo,	*2 00
— Centrifugal Pumps.....	12mo,	*2 00
— The Fan.....	12mo,	*2 00

Isherwood, B. F. Engineering Precedents for Steam Machinery.....	8vo,	2 50
Ivatts, E. B. Railway Management at Stations.....	8vo,	*2 50
Jacob, A., and Gould, E. S. On the Designing and Construction of Storage Reservoirs. (Science Series No. 6.).....	16mo,	0 50
Jamieson, A. Text Book on Steam and Steam Engines.....	8vo,	3 00
— Elementary Manual on Steam and the Steam Engine.....	12mo,	1 50
Jannettaz, E. Guide to the Determination of Rocks. Trans. by G. W. Plympton.....	12mo,	1 50
Jehl, F. Manufacture of Carbons.....	8vo,	*4 00
Jennings, A. S. Commercial Paints and Painting. (Westminster Series.) 8vo (In Press.)		
Jennison, F. H. The Manufacture of Lake Pigments.....	8vo,	*3 00
Jepson, G. Cams and the Principles of their Construction.....	8vo,	*1 50
— Mechanical Drawing.....	8vo (In Preparation.)	
Joekin, W. Arithmetic of the Gold and Silversmith.....	12mo,	*1 00
Johnson, G. L. Photographic Optics and Color Photography.....	8vo,	*3 00
Johnson, J. H. Arc Lamps and Accessory Apparatus. (Installation Manuals Series.).....	12mo,	*0 75
Johnson, T. M. Ship Wiring and Fitting. (Installation Manuals Series).....	12mo,	*0 75
Johnson, W. H. The Cultivation and Preparation of Para Rubber... 8vo,		*3 00
Johnson, W. McA. The Metallurgy of Nickel..... (In Preparation.)		
Johnston, J. F. W., and Cameron, C. Elements of Agricultural Chemistry and Geology.....	12mo,	2 60
Joly, J. Radioactivity and Geology.....	12mo,	*3 00
Jones, H. C. Electrical Nature of Matter and Radioactivity.....	12mo,	*2 00
Jones, M. W. Testing Raw Materials Used in Paint.....	12mo,	*2 00
Jones, L., and Scard, F. I. Manufacture of Cane Sugar.....	8vo,	*5 00
Jordan, L. C. Practical Railway Spiral..... 12mo, Leather, (In Press.)		
Joynton, F. H. Designing and Construction of Machine Gearing... 8vo,		2 00
Jüptner, H. F. V. Siderology: The Science of Iron.....	8vo,	*5 00
Kansas City Bridge.....	4to,	6 00
Kapp, G. Alternate Current Machinery. (Science Series No. 96.) 16mo,		0 50
— Electric Transmission of Energy.....	12mo,	3 50
Keim, A. W. Prevention of Dampness in Buildings.....	8vo,	*2 00
Keller, S. S. Mathematics for Engineering Students. 12mo, half leather. Algebra and Trigonometry, with a Chapter on Vectors.....		*1 75
Special Algebra Edition.....		*1 00
Plane and Solid Geometry.....		*1 25
Analytical Geometry and Calculus.....		*2 00
Kelsey, W. R. Continuous-current Dynamos and Motors.....	8vo,	*2 50
Kemble, W. T., and Underhill, C. R. The Periodic Law and the Hydrogen Spectrum.....	8vo, paper,	*0 50
Kemp, J. F. Handbook of Rocks.....	8vo,	*1 50
Kendall, E. Twelve Figure Cipher Code.....	4to,	*12 50
Kennedy, A. B. W., and Thurston, R. H. Kinematics of Machinery. (Science Series No. 54.).....	16mo,	0 50
Kennedy, A. B. W., Unwin, W. C., and Idell, F. E. Compressed Air. (Science Series No. 106.).....	16mo,	0 50

Kennedy, R. Modern Engines and Power Generators. Six Volumes. 4to,	15 00
Single Volumes. each,	3 00
— Electrical Installations. Five Volumes 4to,	15 00
Single Volumes. each,	3 50
— Flying Machines; Practice and Design 12mo,	*2 00
— Principles of Aeroplane Construction. 8vo,	*1 50
Kennelly, A. E. Electro-dynamic Machinery. 8vo,	1 50
Kent, W. Strength of Materials. (Science Series No. 41.) 16mo,	0 50
Kershaw, J. B. C. Fuel, Water and Gas Analysis. 8vo,	*2 50
— Electrometallurgy. (Westminster Series.) 8vo,	*2 00
— The Electric Furnace in Iron and Steel Production. 12mo,	*1 50
Kinzbrunner, C. Alternate Current Windings. 8vo,	*1 50
— Continuous Current Armatures. 8vo,	*1 50
— Testing of Alternating Current Machines. 8vo,	*2 00
Kirkaldy, W. G. David Kirkaldy's System of Mechanical Testing. . . 4to,	10 00
Kirkbride, J. Engraving for Illustration. 8vo,	*1 50
Kirkwood, J. P. Filtration of River Waters. 4to,	7 50
Klein, J. F. Design of a High-speed Steam-engine. 8vo,	*5 00
— Physical Significance of Entropy. 8vo,	*1 50
Kleinhans, F. B. Boiler Construction. 8vo,	3 00
Knight, R.-Adm. A. M. Modern Seamanship. 8vo,	*7 50
Half morocco.	*9 00
Knox, W. F. Logarithm Tables. (In Preparation.)	
Knott, C. G., and Mackay, J. S. Practical Mathematics. 8vo,	2 00
Koester, F. Steam-Electric Power Plants. 4to,	*5 00
— Hydroelectric Developments and Engineering. 4to,	*5 00
Koller, T. The Utilization of Waste Products. 8vo,	*3 50
— Cosmetics. 8vo,	*2 50
Kretchmar, K. Yarn and Warp Sizing. 8vo,	*4 00
Krischke, A. Gas and Oil Engines. 12mo,	*1 25
Lambert, T. Lead and its Compounds. 8vo,	*3 50
— Bone Products and Manures. 8vo,	*3 00
Lamborn, L. L. Cottonseed Products. 8vo,	*3 00
— Modern Soaps, Candles, and Glycerin. 8vo,	*7 50
Lamprecht, R. Recovery Work After Pit Fires. Trans. by C. Salter. 8vo,	*4 00
Lanchester, F. W. Aerial Flight. Two Volumes. 8vo.	
Vol. I. Aerodynamics.	*6 00
— Aerial Flight. Vol. II. Aerodnetics.	*6 00
Larner, E. T. Principles of Alternating Currents. 12mo,	*1 25
Larrabee, C. S. Cipher and Secret Letter and Telegraphic Code. . . 16mo,	0 60
La Rue, B. F. Swing Bridges. (Science Series No. 107.) 16mo,	0 50
Lassar-Cohn, Dr. Modern Scientific Chemistry. Trans. by M. M. Pattison Muir. 12mo,	*2 00
Latimer, L. H., Field, C. J., and Howell, J. W. Incandescent Electric Lighting. (Science Series No. 57.) 16mo,	0 50
Latta, M. N. Handbook of American Gas-Engineering Practice. . . 8vo,	*4 50
— American Producer Gas Practice. 4to,	*6 00
Leask, A. R. Breakdowns at Sea. 12mo,	2 00
— Refrigerating Machinery. 12mo,	2 00
Lecky, S. T. S. "Wrinkles" in Practical Navigation. 8vo,	*8

Le Doux, M. Ice-Making Machines. (Science Series No. 46.)	16mo,	0 50
Leeds, C. C. Mechanical Drawing for Trade Schools.	oblong 4to,	
High School Edition.		*1 25
Machinery Trades Edition.		*2 00
Lefèvre, L. Architectural Pottery. Trans. by H. K. Bird and W. M. Binns.	4to,	*7 50
Lehner, S. Ink Manufacture. Trans. by A. Morris and H. Robson	8vo,	*2 50
Lemstrom, S. Electricity in Agriculture and Horticulture.	8vo,	*1 50
Le Van, W. B. Steam-Engine Indicator. (Science Series No. 78.)	16mo,	0 50
Lewes, V. B. Liquid and Gaseous Fuels. (Westminster Series.)	8vo,	*2 00
Lewis, L. P. Railway Signal Engineering.	8vo,	*3 50
Lieber, B. F. Lieber's Standard Telegraphic Code.	8vo,	*10 00
— Code. German Edition.	8vo,	*10 00
— — Spanish Edition.	8vo,	*10 00
— — French Edition.	8vo,	*10 00
— Terminal Index.	8vo,	*2 50
— Lieber's Appendix.	folio,	*15 00
— — Handy Tables.	4to,	*2 50
— Bankers and Stockbrokers' Code and Merchants and Shippers' Blank Tables.	8vo,	*15 00
— 100,000,000 Combination Code.	8vo,	*10 00
— Engineering Code.	8vo,	*12 50
Livermore, V. P., and Williams, J. How to Become a Competent Motor-man.	12mo,	*1 00
Livingstone, R. Design and Construction of Commutators.	8vo,	*2 25
Lobben, P. Machinists' and Draftsmen's Handbook	8vo,	2 50
Locke, A. G. and C. G. Manufacture of Sulphuric Acid.	8vo,	10 00
Lockwood, T. D. Electricity, Magnetism, and Electro-telegraph	8vo,	2 50
— Electrical Measurement and the Galvanometer.	12mo,	0 75
Lodge, O. J. Elementary Mechanics.	12mo,	1 50
— Signalling Across Space without Wires.	8vo,	*2 00
Loewenstein, L. C., and Crissey, C. P. Centrifugal Pumps.		*4 50
Lord, R. T. Decorative and Fancy Fabrics.	8vo,	*3 50
Loring, A. E. A Handbook of the Electromagnetic Telegraph.	16mo,	0 50
— Handbook. (Science Series No. 39.)	16mo,	0 50
Low, D. A. Applied Mechanics (Elementary).	16mo,	0 80
Lubschez, B. J. Perspective.		(In Press.)
Lucke, C. E.* Gas Engine Design.	8vo,	*3 00
— Power Plants: Design, Efficiency, and Power Costs. 2 vols. (In Preparation.)		
Lunge, G. Coal-tar and Ammonia. Two Volumes.	8vo,	*15 00
— Manufacture of Sulphuric Acid and Alkali. Four Volumes.	8vo,	
Vol. I. Sulphuric Acid. In two parts.		*15 00
Vol. II. Salt Cake, Hydrochloric Acid and Leblanc Soda. In two parts		*15 00
Vol. III. Ammonia Soda.		*10 00
Vol. IV. Electrolytic Methods.		(In Press.)
— Technical Chemists' Handbook.	12mo, leather,	*3 50
— Technical Methods of Chemical Analysis. Trans. by C. A. Keane. in collaboration with the corps of specialists.		
Vol. I. In two parts.	8vo,	*15 00
Vol. II. In two parts.	8vo,	*18 00
Vol. III.		(In Preparation.)

Lupton, A., Parr, G. D. A., and Perkin, H. Electricity as Applied to Mining.....	8vo,	*4 50
Luquer, L. M. Minerals in Rock Sections.....	8vo,	*1 50
Macewen, H. A. Food Inspection.....	8vo,	*2 50
Mackenzie, N. F. Notes on Irrigation Works.....	8vo,	*2 50
Mackie, J. How to Make a Woolen Mill Pay.....	8vo,	*2 00
Mackrow, C. Naval Architect's and Shipbuilder's Pocket-book.	16mo, leather,	5 00
Maguire, Wm. R. Domestic Sanitary Drainage and Plumbing.....	8vo,	4 00
Mallet, A. Compound Engines. Trans. by R. R. Buel. (Science Series No. 10.).....	16mo,	
Mansfield, A. N. Electro-magnets. (Science Series No. 64.).....	16mo,	0 50
Marks, E. C. R. Construction of Cranes and Lifting Machinery.....	12mo,	*1 50
— Construction and Working of Pumps.....	12mo,	*1 50
— Manufacture of Iron and Steel Tubes.....	12mo,	*2 00
— Mechanical Engineering Materials.....	12mo,	*1 00
Marks, G. C. Hydraulic Power Engineering.....	8vo,	3 50
— Inventions, Patents and Designs.....	12mo,	*1 00
Marlow, T. G. Drying Machinery and Practice.....	8vo,	*5 00
Marsh, C. F. Concise Treatise on Reinforced Concrete.....	8vo,	*2 50
— Reinforced Concrete Compression Member Diagram. Mounted on Cloth Boards.....		*1 50
Marsh, C. F., and Dunn, W. Reinforced Concrete.....	4to,	*5 00
Marsh, C. F., and Dunn, W. Manual of Reinforced Concrete and Concrete Block Construction.....	16mo, morocco,	*2 50
Marshall, W. J., and Sankey, H. R. Gas Engines. (Westminster Series.)	8vo,	*2 00
Martin, G. Triumphs and Wonders of Modern Chemistry.....	8vo,	*2 00
Martin, N. Properties and Design of Reinforced Concrete.		(In Press.)
Massie, W. W., and Underhill, C. R. Wireless Telegraphy and Telephony.	12mo,	*1 00
Matheson, D. Australian Saw-Miller's Log and Timber Ready Reckoner.	12mo, leather,	1 50
Mathot, R. E. Internal Combustion Engines.....	8vo,	*6 00
Maurice, W. Electric Blasting Apparatus and Explosives.....	8vo,	*3 50
— Shot Firer's Guide.....	8vo,	*1 50
Maxwell, J. C. Matter and Motion. (Science Series No. 36.).....	16mo,	0 50
Maxwell, W. H., and Brown, J. T. Encyclopedia of Municipal and Sanitary Engineering.....	4to,	*10 00
Mayer, A. M. Lecture Notes on Physics.....	8vo,	2 00
McCullough, R. S. Mechanical Theory of Heat.....	8vo,	3 50
McIntosh, J. G. Technology of Sugar.....	8vo,	*4 50
— Industrial Alcohol.....	8vo,	*3 00
— Manufacture of Varnishes and Kindred Industries. Three Volumes.	8vo.	
Vol. I. Oil Crushing, Refining and Boiling.....		*3 50
Vol. II. Varnish Materials and Oil Varnish Making.....		*4 00
Vol. III. Spirit Varnishes and Materials.....		*4 50
McKnight, J. D., and Brown, A. W. Marine Multitubular Boilers.....		*1 50

McMaster, J. B. Bridge and Tunnel Centres. (Science Series No. 20.)	16mo,	0 50
McMechen, F. L. Tests for Ores, Minerals and Metals.....	12mo,	*1 00
McNeill, B. McNeill's Code.....	8vo,	*6 00
McPherson, J. A. Water-works Distribution.....	8vo,	2 50
Melick, C. W. Dairy Laboratory Guide.....	12mo,	*1 25
Merck, E. Chemical Reagents; Their Purity and Tests.....	8vo,	*1 50
Merritt, Wm. H. Field Testing for Gold and Silver.....	16mo, leather,	1 50
Messer, W. A. Railway Permanent Way.....	8vo, (<i>In Press.</i>)	
Meyer, J. G. A., and Pecker, C. G. Mechanical Drawing and Machine Design.....	4to,	5 00
Michell, S. Mine Drainage.....	8vo,	10 00
Mierzinski, S. Waterproofing of Fabrics. Trans. by A. Morris and H. Robson.....	8vo,	*2 50
Miller, E. H. Quantitative Analysis for Mining Engineers.....	8vo,	*1 50
Miller, G. A. Determinants. (Science Series No. 105.).....	16mo,	
Milroy, M. E. W. Home Lace-making.....	12mo,	*1 00
Minifie, W. Mechanical Drawing.....	8vo,	*4 00
Mitchell, C. A., and Prideaux, R. M. Fibres Used in Textile and Allied Industries.....	8vo,	*3 00
Modern Meteorology.....	12mo,	1 50
Monckton, C. C. F. Radiotelegraphy. (Westminster Series.).....	8vo,	*2 00
Monteverde, R. D. Vest Pocket Glossary of English-Spanish, Spanish-English Technical Terms.....	64mo, leather,	*1 00
Moore, E. C. S. New Tables for the Complete Solution of Ganguillet and Kutter's Formula.....	8vo,	*5 00
Morecroft, J. H., and Hehre, F. W. Short Course in Electrical Testing.	8vo,	*1 50
Moreing, C. A., and Neal, T. New General and Mining Telegraph Code, 8vo,	8vo,	*5 00
Morgan, A. P. Wireless Telegraph Apparatus for Amateurs.....	12mo,	*1 50
Moses, A. J. The Characters of Crystals.....	8vo,	*2 00
Moses, A. J., and Parsons, C. L. Elements of Mineralogy.....	8vo,	*2 50
Moss, S. A. Elements of Gas Engine Design. (Science Series No. 121.)	16mo,	0 50
— The Lay-out of Corliss Valve Gears. (Science Series No. 119.)	16mo,	0 50
Mulford, A. C. Boundaries and Landmarks.....	(<i>In Press.</i>)	
Mullin, J. P. Modern Moulding and Pattern-making.....	12mo,	2 50
Munby, A. E. Chemistry and Physics of Building Materials. (Westminster Series.).....	8vo,	*2 00
Murphy, J. G. Practical Mining.....	16mo,	1 00
Murray, J. A. Soils and Manures. (Westminster Series.).....	8vo,	*2 00
Naquet, A. Legal Chemistry.....	12mo,	2 00
Nasmith, J. The Student's Cotton Spinning.....	8vo,	3 00
— Recent Cotton Mill Construction.....	12mo,	2 00
Neave, G. B., and Heilbron, I. M. Identification of Organic Compounds.	12mo,	*1 25
Neilson, R. M. Aeroplane Patents.....	8vo,	*2 00
Nerz, F. Searchlights. Trans. by C. Rodgers.....	8vo,	*3 00
Nesbit, A. F. Electricity and Magnetism.....	(<i>In Preparation.</i>)	
Neuberger, H., and Noalhat, H. Technology of Petroleum. Trans. by J. G. McIntosh.....	8vo,	*10 00

Newall, J. W. Drawing, Sizing and Cutting Bevel-gears.....	8vo,	1 50
Nicol, G. Ship Construction and Calculations.....	8vo,	*4 50
Nipher, F. E. Theory of Magnetic Measurements.....	12mo,	1 00
Nisbet, H. Grammar of Textile Design.....	8vo,	*3 00
Nolan, H. The Telescope. (Science Series No. 51.).....	16mo,	0 50
Noll, A. How to Wire Buildings.....	12mo,	1 50
North, H. B. Laboratory Notes of Experiments and General Chemistry. (<i>In Press.</i>)		
Nugent, E. Treatise on Optics.....	12mo,	1 50
O'Connor, H. The Gas Engineer's Pocketbook.....	12mo, leather,	3 50
— Petrol Air Gas.....	12mo,	*0 75
Ohm, G. S., and Lockwood, T. D. Galvanic Circuit. Translated by William Francis. (Science Series No. 102.).....	16mo,	0 50
Olsen, J. C. Text-book of Quantitative Chemical Analysis.....	8vo,	*4 00
Olsson, A. Motor Control, in Turret Turning and Gun Elevating. (U. S. Navy Electrical Series, No. 1.).....	12mo, paper,	*0 50
Oudin, M. A. Standard Polyphase Apparatus and Systems.....	8vo,	*3 00
Pakes, W. C. C., and Nankivell, A. T. The Science of Hygiene.....	8vo,	*1 75
Palaz, A. Industrial Photometry. Trans. by G. W. Patterson, Jr.....	8vo,	*4 00
Pamely, C. Colliery Manager's Handbook.....	8vo,	*10 00
Parr, G. D. A. Electrical Engineering Measuring Instruments.....	8vo,	*3 50
Parry, E. J. Chemistry of Essential Oils and Artificial Perfumes.....	8vo,	*5 00
— Foods and Drugs. Two Volumes.....	8vo,	
Vol. I. Chemical and Microscopical Analysis of Foods and Drugs.....		*7 50
Vol. II. Sale of Food and Drugs Act.....		*3 00
Parry, E. J., and Coste, J. H. Chemistry of Pigments.....	8vo,	*4 50
Parry, L. A. Risk and Dangers of Various Occupations.....	8vo,	*3 00
Parshall, H. F., and Hobart, H. M. Armature Windings.....	4to,	*7 50
— Electric Railway Engineering.....	4to,	*10 00
Parshall, H. F., and Parry, E. Electrical Equipment of Tramways.....	(<i>In Press.</i>)	
Parsons, S. J. Malleable Cast Iron.....	8vo,	*2 50
Partington, J. R. Higher Mathematics for Chemical Students.....	12mo,	*2 00
Passmore, A. C. Technical Terms Used in Architecture.....	8vo,	*3 50
Paterson, G. W. L. Wiring Calculations.....	12mo,	*2 00
Patterson, D. The Color Printing of Carpet Yarns.....	8vo,	*3 50
— Color Matching on Textiles.....	8vo,	*3 00
— The Science of Color Mixing.....	8vo,	*3 00
Paulding, C. P. Condensation of Steam in Covered and Bare Pipes.	8vo,	*2 00
— Transmission of Heat through Cold-storage Insulation.....	12mo,	*1 00
Payne, D. W. Iron Founders' Handbook.....	(<i>In Press.</i>)	
Peddie, R. A. Engineering and Metallurgical Books.....	12mo,	
Peirce, B. System of Analytic Mechanics.....	4to,	10 00
Pendred, V. The Railway Locomotive. (Westminster Series.).....	8vo,	*2 00
Perkin, F. M. Practical Methods of Inorganic Chemistry.....	12mo,	*1 00
Perrigo, O. E. Change Gear Devices.....	8vo,	1 00
Perrine, F. A. C. Conductors for Electrical Distribution.....	8vo,	*3 50
Perry, J. Applied Mechanics.....	8vo,	*2 50
Petit, G. White Lead and Zinc White Paints.....	8vo,	*1 50

Petit, R. How to Build an Aeroplane. Trans. by T. O'B. Hubbard, and J. H. Ledebøer	8vo,	*1 50
Pettit, Lieut. J. S. Graphic Processes. (Science Series No. 76.)...	16mo,	0 50
Philbrick, P. H. Beams and Girders. (Science Series No. 88.)...	16mo,	
Phillips, J. Engineering Chemistry.....	8vo,	*4 50
— Gold Assaying.....	8vo,	*2 50
— Dangerous Goods.....	8vo,	3 50
Phin, J. Seven Follies of Science.....	12mo,	*1 25
Pickworth, C. N. The Indicator Handbook. Two Volumes..	12mo, each,	1 50
— Logarithms for Beginners.....	12mo. boards,	0 50
— The Slide Rule.....	12mo,	1 00
Plattner's Manual of Blow-pipe Analysis. Eighth Edition, revised. Trans. by H. B. Cornwall.....	8vo,	*4 00
Plympton, G. W. The Aneroid Barometer. (Science Series No. 35.)	16mo,	0 50
— How to become an Engineer. (Science Series No. 100.).....	16mo,	0 50
— Van Nostrand's Table Book. (Science Series No. 104.).....	16mo,	0 50
Pochet, M. L. Steam Injectors. Translated from the French. (Science Series No. 29.).....	16mo,	0 50
Pocket Logarithms to Four Places. (Science Series No. 65.).....	16mo,	0 50
	leather,	1 00
Polleyn, F. Dressings and Finishings for Textile Fabrics.....	8vo,	*3 00
Pope, F. L. Modern Practice of the Electric Telegraph.....	8vo,	1 50
Popplewell, W. C. Elementary Treatise on Heat and Heat Engines..	12mo,	*3 00
— Prevention of Smoke.....	8vo,	*3 50
— Strength of Materials.....	8vo,	*1 75
Porter, J. R. Helicopter Flying Machine.....	12mo,	*1 25
Potter, T. Concrete.....	8vo,	*3 00
Potts, H. E. Chemistry of the Rubber Industry. (Outlines of Indus- trial Chemistry).....	8vo,	*2 00
Practical Compounding of Oils, Tallow and Grease.....	8vo,	*3 50
Practical Iron Founding.....	12mo,	1 50
Pratt, K. Boiler Draught.....	12mo,	*1 25
Pray, T., Jr. Twenty Years with the Indicator.....	8vo,	2 50
— Steam Tables and Engine Constant.....	8vo,	2 00
— Calorimeter Tables.....	8vo,	1 00
Preece, W. H. Electric Lamps..... (In Press.)		
Prelini, C. Earth and Rock Excavation.....	8vo,	*3 00
— Graphical Determination of Earth Slopes.....	8vo,	*2 00
— Tunneling. New Edition.....	8vo,	*3 00
— Dredging. A Practical Treatise.....	8vo,	*3 00
Prescott, A. B. Organic Analysis.....	8vo,	5 00
Prescott, A. B., and Johnson, O. C. Qualitative Chemical Analysis..	8vo,	*3 50
Prescott, A. B., and Sullivan, E. C. First Book in Qualitative Chemistry.	12mo,	*1 50
Prideaux, E. B. R. Problems in Physical Chemistry.....	8vo,	*2 00
Pritchard, O. G. The Manufacture of Electric-light Carbons..	8vo, paper,	*0 60
Pullen, W. W. F. Application of Graphic Methods to the Design of Structures.....	12mo,	*2 50
— Injectors: Theory, Construction and Working.....	12mo,	*1 50
Pulsifer, W. H. Notes for a History of Lead.....	8vo,	4 00
Purchase, W. R. Masonry.....	12mo,	*3 00

Putsch, A. Gas and Coal-dust Firing.....	8vo,	*3 00
Pynchon, T. R. Introduction to Chemical Physics.....	8vo,	3 00
Rafter G. W. Mechanics of Ventilation. (Science Series No. 33.).....	16mo,	0 50
— Potable Water. (Science Series No. 103.).....	16mc	50
— Treatment of Septic Sewage. (Science Series No. 118.).....	16mo	50
Rafter, G. W., and Baker, M. N. Sewage Disposal in the United States.	4to,	*6 00
Raikes, H. P. Sewage Disposal Works.....	8vo,	*4 00
Railway Shop Up-to-Date.....	4to,	2 00
Ramp, H. M. Foundry Practice.....	(In Press.)	
Randall, P. M. Quartz Operator's Handbook.....	12mo,	2 00
Randau, P. Enamels and Enamelling.....	8vo,	*4 00
Rankine, W. J. M. Applied Mechanics.....	8vo,	5 00
— Civil Engineering.....	8vo,	6 50
— Machinery and Millwork.....	8vo,	5 00
— The Steam-engine and Other Prime Movers.....	8vo,	5 00
— Useful Rules and Tables.....	8vo,	4 00
Rankine, W. J. M., and Bamber, E. F. A Mechanical Text-book.....	8vo,	3 50
Raphael, F. C. Localization of Faults in Electric Light and Power Mains.	8vo,	*3 00
Rasch, E. Electric Arc. Trans. by K. Tornberg.....	(In Press.)	
Rathbone, R. L. B. Simple Jewellery.....	8vo,	*2 00
Rateau, A. Flow of Steam through Nozzles and Orifices. Trans. by H. B. Brydon.....	8vo,	*1 50
Rausenberger, F. The Theory of the Recoil of Guns.....	8vo,	*4 50
Rautenstrauch, W. Notes on the Elements of Machine Design.....	8vo, boards,	*1 50
Rautenstrauch, W., and Williams, J. T. Machine Drafting and Empirical Design.		
Part I. Machine Drafting.....	8vo,	*1 25
Part II. Empirical Design.....	(In Preparation.)	
Raymond, E. B. Alternating Current Engineering.....	12mo,	*2 50
Rayner, H. Silk Throwing and Waste Silk Spinning.....	8vo,	*2 50
Recipes for the Color, Paint, Varnish, Oil, Soap and Drysaltery Trades.....	8vo,	*3 50
Recipes for Flint Glass Making.....	12mo,	*4 50
Redfern, J. B. Bells, Telephones (Installation Manuals Series).....	16mo,	
	(In Press.)	
Redwood, B. Petroleum. (Science Series No. 92.).....	16mo,	0 50
Reed's Engineers' Handbook.....	8vo,	*5 00
— Key to the Nineteenth Edition of Reed's Engineers' Handbook.....	8vo,	*3 00
— Useful Hints to Sea-going Engineers.....	12mo,	1 50
— Marine Boilers.....	12mo,	2 00
Reinhardt, C. W. Lettering for Draftsmen, Engineers, and Students.		
	oblong 4to, boards,	1 00
— The Technic of Mechanical Drafting.....	oblong 4to, boards,	*1 00
Reiser, F. Hardening and Tempering of Steel. Trans. by A. Morris and H. Robson.....	12mo,	*2 50
Reiser, N. Faults in the Manufacture of Woolen Goods. Trans. by A. Morris and H. Robson.....	8vo,	*2 50
— Spinning and Weaving Calculations.....	8vo,	*5 00
Renwick, W. G. Marble and Marble Working.....	8vo,	5 00

Reynolds, O., and Idell, F. E. Triple Expansion Engines. (Science Series No. 99.)	16mo,	0 50
Rhead, G. F. Simple Structural Woodwork.	12mo,	*1 00
Rice, J. M., and Johnson, W. W. A New Method of Obtaining the Differential of Functions.	12mo,	0 50
Richards, W. A. and North, H. B. Manual of Cement Testing. (<i>In Press.</i>)		
Richardson, J. The Modern Steam Engine.	8vo,	*3 50
Richardson, S. S. Magnetism and Electricity.	12mo,	*2 00
Rideal, S. Glue and Glue Testing.	8vo,	*4 00
Rings, F. Concrete in Theory and Practice.	12mo,	*2 50
Ripper, W. Course of Instruction in Machine Drawing.	folio,	*6 00
Roberts, F. C. Figure of the Earth. (Science Series No. 79.)	16mo,	0 50
Roberts, J., Jr. Laboratory Work in Electrical Engineering.	8vo,	*2 00
Robertson, L. S. Water-tube Boilers.	8vo,	3 00
Robinson, J. B. Architectural Composition.	8vo,	*2 50
Robinson, S. W. Practical Treatise on the Teeth of Wheels. (Science Series No. 24.)	16mo,	0 50
— Railroad Economics. (Science Series No. 59.)	16mo,	0 50
— Wrought Iron Bridge Members. (Science Series No. 60.)	16mo,	0 50
Robson, J. H. Machine Drawing and Sketching.	8vo,	*1 50
Roebing, J. A. Long and Short Span Railway Bridges.	folio,	25 00
Rogers, A. A Laboratory Guide of Industrial Chemistry.	12mo,	*1 50
Rogers, A., and Aubert, A. B. Industrial Chemistry.	8vo,	*5 00
Rogers, F. Magnetism of Iron Vessels. (Science Series No. 30.)	16mo,	0 50
Rohland, P. Colloidal and Crystalloidal State of Matter. Trans. by W. J. Britland and H. E. Potts.	12mo,	*1 25
Rollins, W. Notes on X-Light.	8vo,	*5 00
Rollinson, C. Alphabets.	Oblong, 12mo, (<i>In Press.</i>)	
Rose, J. The Pattern-makers' Assistant.	8vo,	2 50
— Key to Engines and Engine-running.	12mo,	2 50
Rose, T. K. The Precious Metals. (Westminster Series.)	8vo,	*2 00
Rosenhain, W. Glass Manufacture. (Westminster Series.)	8vo,	*2 00
Ross, W. A. Plowpipe in Chemistry and Metallurgy.	12mo,	*2 00
Rossiter, J. T. Steam Engines. (Westminster Series.)	8vo (<i>In Press.</i>)	
— Pumps and Pumping Machinery. (Westminster Series.)	8vo (<i>In Press.</i>)	
Roth. Physical Chemistry.	8vo,	*2 00
Rouillion, L. The Economics of Manual Training.	8vo,	2 00
Rowan, F. J. Practical Physics of the Modern Steam-boiler.	8vo,	7 50
Rowan, F. J., and Idell, F. E. Boiler Incrustation and Corrosion. (Science Series No. 27.)	16mo,	0 50
Roxburgh, W. General Foundry Practice.	8vo,	*3 50
Ruhmer, E. Wireless Telephony. Trans. by J. Erskine-Murray.	8vo,	*3 50
Russell, A. Theory of Electric Cables and Networks.	8vo,	*3 00
Sabine, R. History and Progress of the Electric Telegraph.	12mo,	1 25
Saeltzer A. Treatise on Acoustics.	12mo,	1 00
Salomons, D. Electric Light Installations. 12mo.		
Vol. I. The Management of Accumulators.		2 50
Vol. II. Apparatus.		2 25
Vol. III. Applications.		1 50
Sanford, P. G. Nitro-explosives.	8vo,	*4 00

Saunders, C. H. Handbook of Practical Mechanics.....	16mo,	1 00
	leather,	1 25
Saunier, C. Watchmaker's Handbook.....	12mo,	3 00
Sayers, H. M. Brakes for Tram Cars.....	8vo,	*1 25
Scheele, C. W. Chemical Essays.....	8vo,	*2 00
Schellen, H. Magneto-electric and Dynamo-electric Machines.....	8vo,	5 00
Scherer, R. Casein. Trans. by C. Salter.....	8vo,	*3 00
Schidrowitz, P. Rubber, Its Production and Industrial Uses.....	8vo,	*5 00
Schindler, K. Iron and Steel Construction Works.		
Schmall, C. N. First Course in Analytic Geometry, Plane and Solid.		
	12mo, half leather,	*1 75
Schmall, C. N., and Shack, S. M. Elements of Plane Geometry.....	12mo,	*1 25
Schmeer, L. Flow of Water.....	8vo,	*3 00
Schumann, F. A Manual of Heating and Ventilation.....	12mo, leather,	1 50
Schwarz, E. H. L. Causal Geology.....	8vo,	*2 50
Schweizer, V., Distillation of Resins.....	8vo,	*3 50
Scott, W. W. Qualitative Analysis. A Laboratory Manual.....	8vo,	*1 50
Scribner, J. M. Engineers' and Mechanics' Companion.....	16mo, leather,	1 50
Searle, A. B. Modern Brickmaking.....	8vo,	*5 00
Searle, G. M. "Summers' Method." Condensed and Improved. (Science Series No. 124.).....	16mo,	0 50
Seaton, A. E. Manual of Marine Engineering.....	8vo,	6 00
Seaton, A. E., and Rounthwaite, H. M. Pocket-book of Marine Engineering.....	16mo, leather,	3 00
Seeligmann, T., Torrilhon, G. L., and Falconnet, H. India Rubber and Gutta Percha. Trans. by J. G. McIntosh.....	8vo,	*5 00
Seidell, A. Solubilities of Inorganic and Organic Substances.....	8vo,	*3 00
Sellew, W. H. Steel Rails.....	4to (<i>In Press.</i>)	
Senter, G. Outlines of Physical Chemistry.....	12mo,	*1 75
— Textbook of Inorganic Chemistry.....	12mo,	*1 75
Sever, G. F. Electric Engineering Experiments.....	8vo, boards,	*1 00
Sever, G. F., and Townsend, F. Laboratory and Factory Tests in Electrical Engineering.....	8vo,	*2 50
Sewall, C. H. Wireless Telegraphy.....	8vo,	*2 00
— Lessons in Telegraphy.....	12mo,	*1 00
Sewell, T. Elements of Electrical Engineering.....	8vo,	*3 00
— The Construction of Dynamos.....	8mo,	*3 00
Sexton, A. H. Fuel and Refractory Materials.....	12mo,	*2 50
— Chemistry of the Materials of Engineering.....	12mo,	*2 50
— Alloys (Non-Ferrous).....	8vo,	*3 00
— The Metallurgy of Iron and Steel.....	8vo,	*6 50
Seymour, A. Practical Lithography.....	8vo,	*2 50
— Modern Printing Inks.....	8vo,	*2 00
Shaw, Henry S. H. Mechanical Integrators. (Science Series No. 83.)		
	16mo,	0 50
Shaw, P. E. Course of Practical Magnetism and Electricity.....	8vo,	*1 00
Shaw, S. History of the Staffordshire Potteries.....	8vo,	*3 00
— Chemistry of Compounds Used in Porcelain Manufacture.....	8vo,	*5 00
Shaw, W. N. Forecasting Weather.....	8vo,	*3 50
Sheldon, S., and Hausmann, E. Direct Current Machines.....	12mo,	*2 50
— Alternating Current Machines.....	12mo,	*2 50

Tidy, C. Meymott. Treatment of Sewage. (Science Series No. 94.)	16mo,	0 50
Tinney, W. H. Gold-mining Machinery	8vo,	*3 00
Titherley, A. W. Laboratory Course of Organic Chemistry	8vo,	*2 00
Toch, M. Chemistry and Technology of Mixed Paints	8vo,	*3 00
— Materials for Permanent Painting	12mo,	*2 00
Todd, J., and Whall, W. B. Practical Seamanship	8vo,	*7 50
Tonge, J. Coal. (Westminster Series.)	8vo,	*2 00
Townsend, F. Alternating Current Engineering	8vo, boards	*0 75
Townsend, J. Ionization of Gases by Collision	8vo,	*1 25
Transactions of the American Institute of Chemical Engineers. 8vo.		
Vol. I. 1908		*6 00
Vol. II. 1909		*6 00
Vol. III. 1910		*6 00
Vol. IV. 1911		*6 00
Traverse Tables. (Science Series No. 115.)	16mo,	0 50
	morocco,	1 00
Trinks, W., and Housum, C. Shaft Governors. (Science Series No. 122.)	16mo,	0 50
Trowbridge, W. P. Turbine Wheels. (Science Series No. 44.)	16mo,	0 50
Tucker, J. H. A Manual of Sugar Analysis	8vo,	3 50
Tumlirz, O. Potential. Trans. by D. Robertson	12mo,	1 25
Tunner, P. A. Treatise on Roll-turning. Trans. by J. B. Pearse.	8vo, text and folio atlas,	10 00
Turbayne, A. A. Alphabets and Numerals	4to,	2 00
Turnbull, Jr., J., and Robinson, S. W. A Treatise on the Compound Steam-engine, (Science Series No. 8.)	16mo,	
Turrill, S. M. Elementary Course in Perspective	12mo,	*1 25
Underhill, C. R. Solenoids, Electromagnets and Electromagnetic Windings	12mo,	*2 00
Universal Telegraph Cipher Code	12mo,	1 00
Urquhart, J. W. Electric Light Fitting	12mo,	2 00
— Electro-plating	12mo,	2 00
— Electrotyping	12mo,	2 00
— Electric Ship Lighting	12mo,	3 00
Vacher, F. Food Inspector's Handbook	12mo,	*2 50
Van Nostrand's Chemical Annual. Second issue 1909	12mo,	*2 50
— Year Book of Mechanical Engineering Data. First issue 1912. (<i>In Press.</i>)		
Van Wagenen, T. F. Manual of Hydraulic Mining	16mo,	1 00
Vega, Baron Von. Logarithmic Tables	8vo, half morocco,	2 00
Villon, A. M. Practical Treatise on the Leather Industry. Trans. by F. T. Addyman	8vo,	*10 00
Vincent, C. Ammonia and its Compounds. Trans. by M. J. Salter	8vo,	*2 00
Volk, C. Haulage and Winding Appliances	8vo,	*4 00
Von Georgievics, G. Chemical Technology of Textile Fibres. Trans. by C. Salter	8vo,	*4 50
— Chemistry of Dyestuffs. Trans. by C. Salter	8vo,	*4 50
Vose, G. L. Graphic Method for Solving Certain Questions in Arithmetic and Algebra. (Science Series No. 16.)	16mo,	0 50

Wabner, R. Ventilation in Mines. Trans. by C. Salter.....	8vo,	*4 50
Wade, E. J. Secondary Batteries.....	8vo,	*4 00
Wadmore, T. M. Elementary Chemical Theory.....	12mo,	*1 50
Wadsworth, C. Primary Battery Ignition.....	12mo (<i>In Press.</i>)	
Wagner, E. Preserving Fruits, Vegetables, and Meat.....	12mo,	*2 50
Waldram, P. J. Principles of Structural Mechanics.....	(<i>In Press.</i>)	
Walker, F. Aerial Navigation.....	8vo,	2 00
— Dynamo Building. (Science Series No. 98.).....	16mo,	0 50
— Electric Lighting for Marine Engineers.....	8vo,	2 00
Walker, S. F. Steam Boilers, Engines and Turbines.....	8vo,	3 00
— Refrigeration, Heating and Ventilation on Shipboard.....	12mo,	*2 00
— Electricity in Mining.....	8vo,	*3 50
Walker, W. H. Screw Propulsion.....	8vo,	0 75
Wallis-Taylor, A. J. Bearings and Lubrication.....	8vo,	*1 50
— Aerial or Wire Ropeways.....	8vo,	*3 00
— Modern Cycles.....	8vo,	4 00
— Motor Cars.....	8vo,	1 80
— Motor Vehicles for Business Purposes.....	8vo,	3 50
— Pocket Book of Refrigeration and Ice Making.....	12mo,	1 50
— Refrigeration, Cold Storage and Ice-Making.....	8vo,	*4 50
— Sugar Machinery.....	12mo,	*2 00
Wanklyn, J. Å. Water Analysis.....	12mo,	2 00
Wansbrough, W. D. The A B C of the Differential Calculus.....	12mo,	*1 50
— Slide Valves.....	12mo,	*2 00
Ward, J. H. Steam for the Million.....	8vo,	1 00
Waring, Jr., G. E. Sanitary Conditions. (Science Series No. 31.).....	16mo,	0 50
— Sewerage and Land Drainage.....		*6 00
Waring, Jr., G. E. Modern Methods of Sewage Disposal.....	12mo,	2 00
— How to Drain a House.....	12mo,	1 25
Warren, F. D. Handbook on Reinforced Concrete.....	12mo,	*2 50
Watkins, A. Photography. (Westminster Series.).....	8vo,	*2 00
Watson, E. P. Small Engines and Boilers.....	12mo,	1 25
Watt, A. Electro-plating and Electro-refining of Metals.....	8vo,	*4 50
— Electro-metallurgy.....	12mo,	1 00
— The Art of Soap-making.....	8vo,	3 00
— Leather Manufacture.....	8vo,	*4 00
— Paper-Making.....	8vo,	3 00
Weale, J. Dictionary of Terms Used in Architecture.....	12mo,	2 50
Weale's Scientific and Technical Series. (Complete list sent on applica- tion.)		
Weather and Weather Instruments.....	12mo,	1 00
	paper,	0 50
Webb, H. L. Guide to the Testing of Insulated Wires and Cables.....	12mo,	1 00
Webber, W. H. Y. Town Gas. (Westminster Series.).....	8vo,	*2 00
Weisbach, J. A Manual of Theoretical Mechanics.....	8vo,	*6 00
	sheep,	*7 50
Weisbach, J., and Herrmann, G. Mechanics of Air Machinery.....	8vo,	*3 75
Welch, W. Correct Lettering.....	(<i>In Press.</i>)	
Weston, E. B. Loss of Head Due to Friction of Water in Pipes.....	12mo,	*1 50
Weymouth, F. M. Drum Armatures and Commutators.....	8vo,	*3 00
Wheatley, O. Ornamental Cement Work.....	(<i>In Press.</i>)	

Wheeler, J. B. Art of War.....	12mo,	1 75
— Field Fortifications.....	12mo,	1 75
Whipple, S. An Elementary and Practical Treatise on Bridge Building.	8vo,	3 00
Whithard, P. Illuminating and Missal Painting.....	12mo,	1 50
Wilcox, R. M. Cantilever Bridges. (Science Series No. 25.).....	16mo,	0 50
Wilkinson, H. D. Submarine Cable Laying and Repairing.....	8vo,	*6 00
Williams, A. D., Jr., and Hutchinson, R. W. The Steam Turbine....	(In Press.)	
Williamson, J., and Blackadder, H. Surveying.....	8vo, (In Press.)	
Williamson, R. S. On the Use of the Barometer.....	4to,	15 00
— Practical Tables in Meteorology and Hypsometry.....	4to,	2 50
Willson, F. N. Theoretical and Practical Graphics.....	4to,	*4 00
Wimperis, H. E. Internal Combustion Engine.....	8vo,	*3 00
Winchell, N. H., and A. N. Elements of Optical Mineralogy.....	8vo,	*3 50
Winkler, C., and Lunge, G. Handbook of Technical Gas-Analysis... 8vo,		4 00
Winslow, A. Stadia Surveying. (Science Series No. 77.).....	16mo,	0 50
Wisser, Lieut. J. P. Explosive Materials. (Science Series No. 70.)	16mo,	0 50
Wisser, Lieut. J. P. Modern Gun Cotton. (Science Series No. 89.)	16mo,	0 50
Wood, De V. Luminiferous Aether. (Science Series No. 85.)....	16mo,	0 50
Woodbury, D. V. Elements of Stability in the Well-proportioned Arch.	8vo, half morocco,	4 00
Worden, E. C. The Nitrocellulose Industry. Two Volumes.....	8vo, *10 00	
— Cellulose Acetate.....	8vo, (In Press.)	
Wright, A. C. Analysis of Oils and Allied Substances.....	8vo,	*3 50
— Simple Method for Testing Painters' Materials.....	8vo,	*2 50
Wright, F. W. Design of a Condensing Plant.....	12mo,	*1 50
Wright, H. E. Handy Book for Brewers.....	8vo,	*5 00
Wright, J. Testing, Fault Finding, etc., for Wiremen. (Installation Manuals Series.).....	16mo,	*0 50
Wright, T. W. Elements of Mechanics.....	8vo,	*2 50
Wright, T. W., and Hayford, J. F. Adjustment of Observations....	8vo,	*3 00
Young, J. E. Electrical Testing for Telegraph Engineers.....	8vo,	*4 00
Zahner, R. Transmission of Power. (Science Series No. 40.)....	16mo,	
Zeidler, J., and Lustgarten, J. Electric Arc Lamps.....	8vo,	*2 00
Zeuner, A. Technical Thermodynamics. Trans. by J. F. Klein. Two Volumes.....	8vo,	*8 00
Zimmer, G. F. Mechanical Handling of Material.....	4to,	*10 00
Zipser, J. Textile Raw Materials. Trans. by C. Salter.....	8vo,	*5 00
Zur Nedden, F. Engineering Workshop Machines and Processes. Trans. by J. A. Davenport.....	8vo	*2 00

PLEASE DO NOT REMOVE
CARDS OR SLIPS FROM THIS POCKET

UNIVERSITY OF TORONTO LIBRARY

S&M
A
556

