

## Historic, archived document

Do not assume content reflects current scientific knowledge, policies, or practices.



84 B  
no. 379

**UNITED STATES DEPARTMENT OF AGRICULTURE**  
**BULLETIN No. 379**

Contribution from the Bureau of Chemistry, CARL L. ALSBERG, Chief, and the Office of Public Roads and Rural Engineering, LOGAN WALLER PAGE, Director

Washington, D. C.



August 4, 1916

**DUST EXPLOSIONS AND FIRES IN**  
**GRAIN SEPARATORS IN THE**  
**PACIFIC NORTHWEST**

By

**DAVID J. PRICE**, Engineer in Charge of Grain Dust Explosion Investigations, Bureau of Chemistry, and **E. B. McCORMICK**, Chief, Division of Rural Engineering, Office of Public Roads and Rural Engineering

**CONTENTS**

	Page		Page
Introduction . . . . .	1	Experimental Field and Laboratory Work . . . . .	11
Plan of Investigation . . . . .	2	Nature of Dust Explosions . . . . .	17
Classification of Explosions . . . . .	3	Methods Developed for Preventing Explosions or Extinguishing Fires . . . . .	19
Results of Field Investigation . . . . .	6	Special Acknowledgments . . . . .	22
Static Electricity as a Cause of Explosions . . . . .	9		



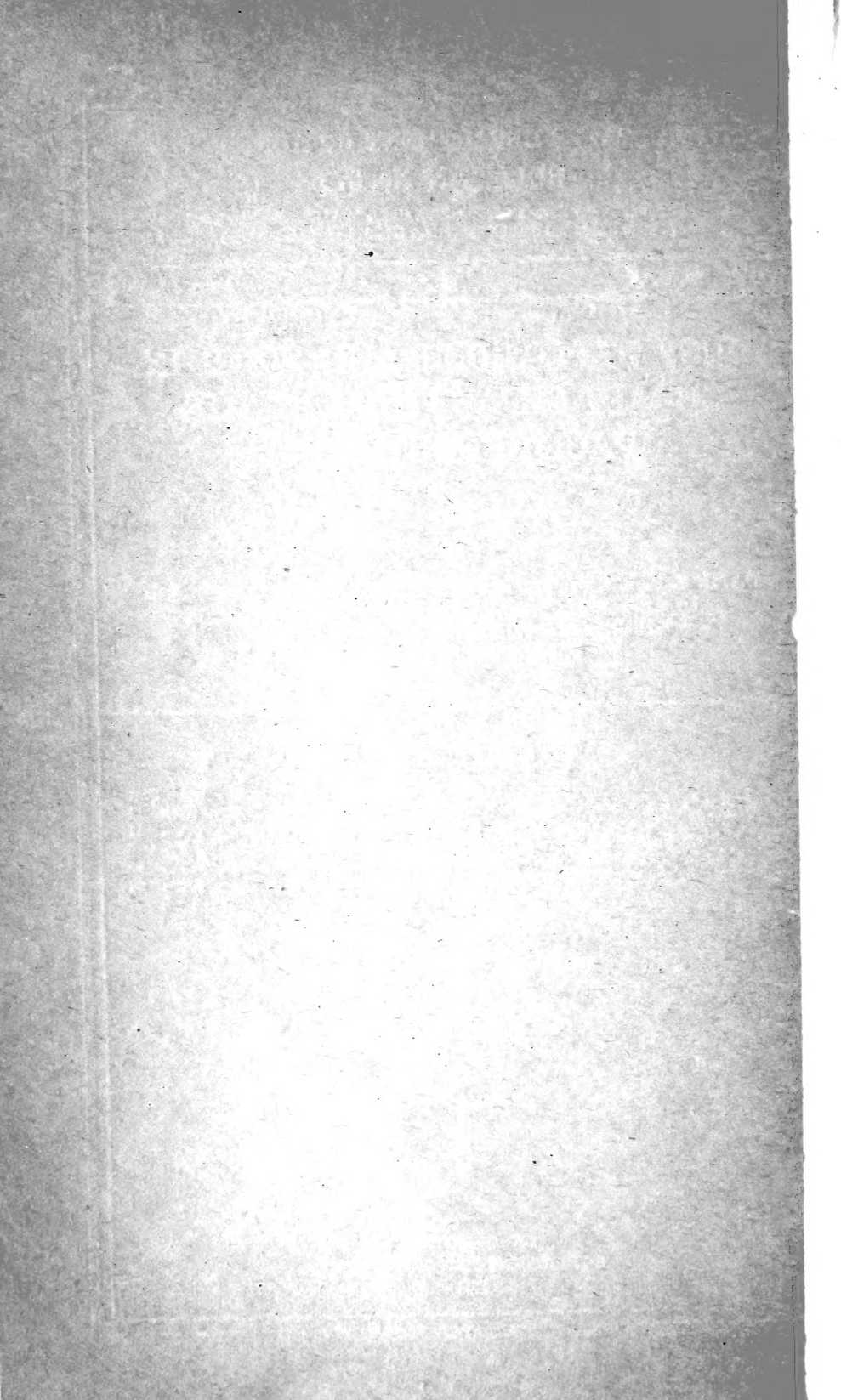

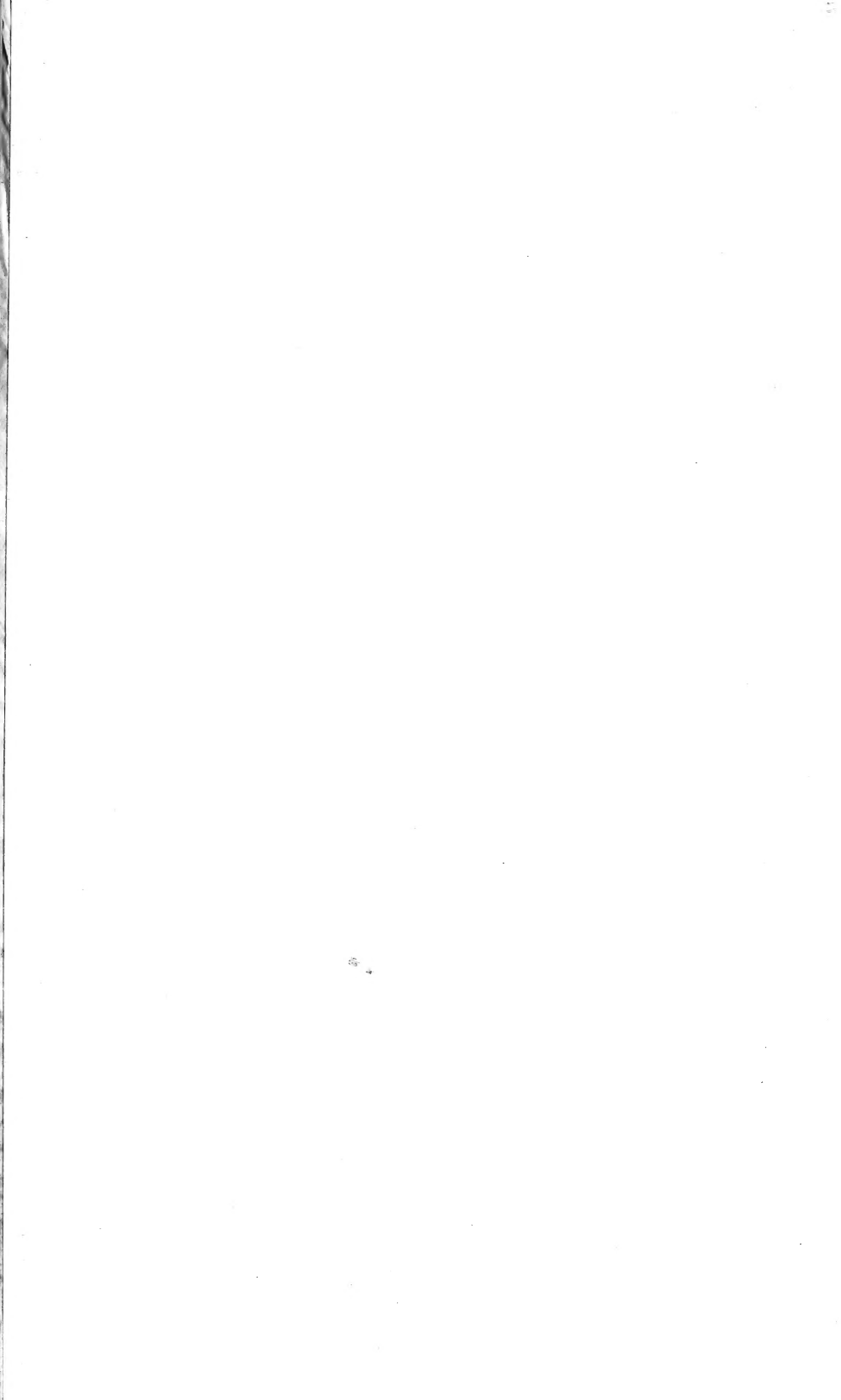

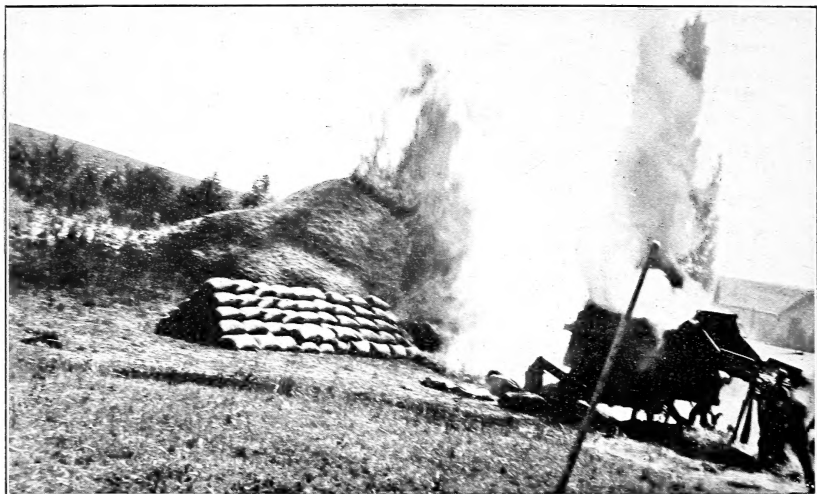

FIG. 1.—SMUT-DUST EXPLOSION IN THRESHING MACHINE IN EASTERN WASHINGTON. PHOTOGRAPH WAS TAKEN AT TIME EXPLOSION AND FIRE OCCURRED.

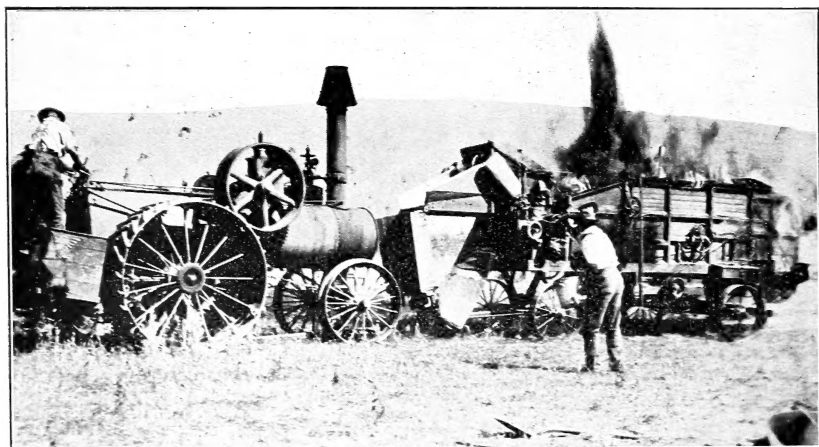

FIG. 2.—ENGINE PULLING A MACHINE AWAY FROM STRAW STACK AFTER EXPLOSION AND FIRE.



**BULLETIN No. 379**



Contribution from the Bureau of Chemistry  
 CARL L. ALSBERG, Chief, and the  
 Office of Public Roads and Rural Engineering  
 LOGAN WALLER PAGE, Director

Washington, D. C.

August 4, 1916

**DUST EXPLOSIONS AND FIRES IN GRAIN SEPARATORS IN THE PACIFIC NORTHWEST.**

By DAVID J. PRICE, *Engineer in Charge of Grain Dust Explosion Investigations, Bureau of Chemistry*, and E. B. McCORMICK, *Chief, Division of Rural Engineering, Office of Public Roads and Rural Engineering.*

**CONTENTS.**

	Page.		Page.
Introduction .....	1	Experimental field and laboratory	
Plan of investigation .....	2	work .....	11
Classification of explosions .....	3	Nature of dust explosions .....	17
Results of field investigation .....	6	Methods developed for preventing ex-	
Static electricity as a cause of ex-		plosions or extinguishing fires .....	19
plosions .....	9	Special acknowledgments .....	22

**INTRODUCTION.**

The large number of fires and explosions in grain separators during the threshing process has awakened unusual interest in the Pacific Northwest during the last two seasons. These fires and explosions were most frequent in the wheat-growing territory in eastern Washington and northern Idaho, although occasional occurrences were reported in adjoining territory in northeastern Oregon. From reports received from various sources it is apparent that similar explosions and fires have occurred in scattered localities throughout the territory west of the Mississippi River.

The Department of Agriculture had for some time been conducting studies relative to the causes and prevention of dust explosions in grain mills, elevators, and similar plants. The close relation of thresher explosions to the general study of grain-dust explosions led to the inauguration of a special study of this allied problem in the northwestern field during the 1915 season. As a result of this study 166 occurrences were investigated and reported. It is probable that many other explosions and fires took place which were not brought to the attention of the department.

The results of the investigation indicate that the wheat crop contained a large percentage of smut and that the explosions and fires in many cases were due to the formation of an explosive mixture of smut dust and air and the ignition of this mixture by static electricity during the threshing operations. This report briefly summarizes the results of the field work relative to the causes of ignition and describes the various preventive devices developed as a result of the investigation.

## PLAN OF INVESTIGATION.

### ORGANIZATION.

The field work was conducted under a cooperative arrangement between the Bureau of Chemistry, where the general study of grain-dust explosions is being carried on, and the Office of Public Roads and Rural Engineering. Investigators were assigned to the various parts of the territory affected and a central office was opened in the Federal building at Spokane, Wash. J. E. Young, assistant agricultural engineer, conducted field investigations in the vicinity of Walla Walla and Rosalia, Wash., and J. C. Woodson, assistant agricultural engineer, in the territory adjacent to Moscow, Idaho. H. H. Brown, assistant chemist, was assigned to investigations in the vicinity of Colfax, Wash. The organization and direction of the field work and the conduct of the investigation were in charge of David J. Price, engineer, of the Bureau of Chemistry, and E. B. McCormick, mechanical engineer, of the Office of Public Roads and Rural Engineering.

### COOPERATION WITH THE UNIVERSITY OF IDAHO.

The investigations in northern Idaho were conducted in cooperation with the University of Idaho at Moscow, represented by Prof. N. S. Robb, of the Department of Farm Crops. Office room, laboratories, and electrical apparatus were placed at the disposal of the investigators and experimental work was conducted in conjunction with Prof. Angell, of the Department of Physics. The staff was much interested in the explosion problem in its territory and rendered valuable assistance during the conduct of the investigations.

### CONFERENCES WITH THE STATE COLLEGE OF WASHINGTON.

Conferences were held at the beginning of the investigations with Dr. Ira D. Cardiff, director of the experiment station, State College of Washington, Pullman, Wash., and members of the staff. This problem had been studied by the station staff in 1914 and the results published in bulletin form.<sup>1</sup> During the conduct of the field work

<sup>1</sup> Washington Station Bulletin No. 117, Nov. 3, 1914. Report on Fires Occurring in Threshing Separators in Eastern Washington during the Summer of 1914.



various phases of the problem were considered with the State College staff.

#### CONDUCT OF INVESTIGATIONS.

Although investigations by the Department of Agriculture were not conducted in the field during the 1914 threshing season, samples of wheat smut dust from the Pacific Northwest were obtained at the close of the season. Experiments at that time indicated that the material was highly inflammable and might be associated with the frequent fires and explosions in grain separators.

The entire season extending from the first week in July to the middle of September, 1915, was spent in field work in the territory. Effort was made to visit the scene of each explosion or fire as soon as possible after it had taken place and obtain all the available information pertaining to the occurrence. Arrangements previously had been made so that prompt reports could be received at the Spokane office, through various channels, and also by the men in the field, so that no time would be lost in reaching the scene of the explosion. In nearly 150 cases the investigator was on the ground either immediately or within a few hours after the occurrence. In many instances the explosions were so sudden and violent that the crew could give very little information, but it was possible in the majority of cases to make valuable deductions. A large percentage of the thresher owners would not advance an opinion, but many of them believed that matches or explosives had been placed in the bundles. In many cases, however, this was mere conjecture and not supported by evidence.

#### CLASSIFICATION OF EXPLOSIONS.

##### TERRITORY AFFECTED.

The largest number of the 166 explosions reported occurred in the counties of Whitman and Spokane in eastern Washington, and the counties of Latah, Lewis, Kootenai, and Nez Perce, in northern Idaho. Eighty-three per cent of the total number of explosions and fires reported occurred in this district. Of these 70 per cent occurred in Washington and 13 per cent in Idaho. About 11 per cent of the total number reported occurred in the Big Bend section in the Columbia River Valley in Washington, comprising the counties of Adams, Lincoln, Grant, and Douglas. The remaining explosions occurred in Walla Walla, Garfield, Yakima, and Klickitat Counties. The field investigations, however, generally were confined to the Palouse country in eastern Washington and the northern Idaho territory.

##### FREQUENCY OF EXPLOSIONS.

The explosions began with the opening of the season in the Big Bend country about the middle of July and continued until the

middle of September. They increased in frequency as the season progressed until it was not unusual to have from 6 to 10 a day. On both August 11 and August 16 there were 11 explosions and fires reported, and the total for the week from August 9 to 14 reached 46, an average of between 6 and 7 a day. The explosions were classified by days and weeks as follows:

July 12-17-----	1	Sept. 20-----	1
July 19-24-----	3		
July 26-31-----	6		166
Aug. 2-7-----	32	July-----	10
Aug. 9-14-----	46	August-----	149
Aug. 16-21-----	33	September-----	7
Aug. 22-28-----	29	Maximum, one week-----	46
Aug. 30-Sept. 4-----	13	Maximum, one day, Aug. 10, 16---	11
Sept. 6-11-----	2		

#### CLASSIFICATION BY TIME OF DAY.

The explosions and fires occurred at all times during the day. The following tabulation shows the time of 128 occurrences:

5 to 6 a. m.-----	5	2 to 3 p. m.-----	14
6 to 7 a. m.-----	5	3 to 4 p. m.-----	13
7 to 8 a. m.-----	3	4 to 5 p. m.-----	12
8 to 9 a. m.-----	3	5 to 6 p. m.-----	17
9 to 10 a. m.-----	9	6 to 7 p. m.-----	17
10 to 11 a. m.-----	4	7 to 8 p. m.-----	5
11 to 12 noon-----	10		
12 to 1 p. m.-----	3		128
1 to 2 p. m.-----	8		

From this it will be noted that the greatest number of explosions occurred between the hours of 1 and 7 p. m.

#### MAKE OF MACHINES.

The explosions were generally distributed among all types of separators operated in the territory and were not confined to any one make or type. It was thought that possibly the explosions and fires were confined to stationary machines, but investigators learned that there were at least three occurrences in the "combine" type.

The investigation shows that the explosions occurred in both steel and wooden separators. In view of the fact that data are not available to determine the number of machines of each type in the territory, it is impossible to state the percentage of each affected.

## NATURE OF EXPLOSIONS.

The nature of the explosions and fires in 117 cases can be summarized as follows:

<i>Explosions.</i>		<i>Fires.</i>	
Sudden puff.....	68	Without explosions.....	21
Very violent.....	8	Nature not determined.....	1
Small puff.....	10		
Slight explosion.....	2		22
Muffled and quick.....	5		
Flame followed by explosion.....	1		
Detonation report.....	1		
	95		

This table indicates that at least 95 of the occurrences, or 81 per cent, were dust explosions. In the remaining cases where there was sufficient flame to damage the machine the fire was not accompanied by as loud reports as in the other instances. The ignition was not so rapid and the rate of burning accordingly slower.

## POINT OF ORIGIN OF EXPLOSIONS.

Special efforts were made by the investigators to locate the point of origin of the explosions and fires. The results in 108 cases can be summarized as follows:

Back of cylinder or near this point.....	82	Grain pan.....	1
Entire machine.....	9	Straw stack.....	1
Behind knives.....	5	Back of machine.....	1
Blower.....	4	Engine.....	1
Center of machine.....	2		
Front of machine.....	2		108

At least 82 of these occurrences, or 76 per cent, originated back of the cylinder or very near this point, indicating that the source of ignition in a large majority of cases was near this part of the separator.

## LOCAL OPINION AS TO CAUSES.

During the preliminary field investigations an effort was made to interview the thresher agents of the various companies in the vicinity of Spokane and other interested parties with a view to obtaining information pertaining to the local opinion regarding causes of previous explosions and fires. Prior to 1914 occasional occurrences of this nature had taken place throughout the Pacific Northwest, but until 1914 general interest was not awakened. During that year, owing to the frequency of the explosions and fires, local interest was greatly increased.

Early results prior to the opening of the threshing season indicated that opinion as to the cause of explosions and fires of this nature was divided between natural causes and incendiarism. The principal reason advanced for this latter conclusion was that prior to the 1914 season explosions were not very frequent. This led to the conclusion that means were being taken maliciously to destroy the separators by introducing matches and explosives into the grain bundles.

The following summary indicates the local opinion advanced as to the causes of 121 explosions personally investigated during the 1915 season:

Matches, incendiary, and accidental.....	60	Crowding machine .....	1
Not given, and indefinite.....	14		121
Foreign material, sparks from same .....	14		Per cent.
Smut explosion.....	14	Believed to be incendiary.....	49
Static electricity.....	10	Foreign material.....	11
Powder or explosives.....	4	Smut explosion.....	11
Engine sparks .....	2	Static electricity.....	8.2
Bent spikes.....	1	Not given.....	11
Hot boxes .....	1		

In connection with obtaining the opinions of the local thresher men and the grain owners, a special effort also was made to secure any evidence sustaining the conclusions advanced. In the great majority of cases there was no definite reason for supporting the conclusion which was based frequently on current rumors. In some cases, however, matches were found in the grain pan, but it was impossible to determine whether they had fallen into the machines accidentally or had been introduced intentionally.

## RESULTS OF FIELD INVESTIGATION.

### SUMMARY OF INVESTIGATORS' OPINIONS.

In each explosion and fire the investigator summarized the evidence obtainable, and after careful consideration of all information available assigned the cause most probable in his opinion. The following summary shows the conclusions reached in 94 special cases investigated:

Static electricity.....	45	Incendiary.....	1
Smut explosion.....	25	Beater striking conveyor.....	1
Friction sparks.....	10	No clue.....	1
Matches.....	5		94
Doubtful.....	5		
Teeth striking.....	1		

About 75 per cent of the occurrences were assigned to the presence of static electricity and to smut explosions. The percentage assigned

by the investigators as indicating incendiary origin was very small as compared with that advanced by local men.

#### PERCENTAGE OF SMUTTED HEADS.

The percentage of smut present in the wheat crop was determined in each case by taking a sample of a known number of heads and separating it into two parts, one part consisting of those heads which were not affected by smut, the other part of those heads which were affected. The proportion of smutted heads to the whole number of heads in the sample gave the percentage of smutted heads present in the crop.

Of 112 explosions nearly all occurred during the threshing of grain which contained from 1 to 35 per cent of smutted heads; the average percentage in 108 explosions was 15. There were only three explosions in fields reported to contain no smut.

Percentage of smutted heads.	No. of explosions.	Percentage of smutted heads.	No. of explosions.
No smut.....	3	15 to 20 per cent.....	20
Less than 1 per cent.....	4	22 to 25 per cent.....	8
1 to 5 per cent.....	19	25 to 30 per cent.....	7
5 to 10 per cent.....	27	30 to 35 per cent.....	5
10 to 15 per cent.....	15	Not known.....	4

#### SIZE OF MACHINE.

The results of the investigation in relation to the size of machines affected indicate that explosions occurred in all kinds and types of machines, irrespective of size.

#### SPEED OF CYLINDER.

The fact that many explosions occurred while the separator was being operated at the cylinder speed recommended by the manufacturers indicates that operation of the machine at excessive speed is not essential to produce an explosion.

#### POWER USED.

The kind of power used in operating the machine was of special importance, since one of the early suggestions as to cause was that engine sparks were responsible. It was found that explosions and fires took place in gasoline-driven as well as in steam-driven outfits, and that the cause of ignition was within the machine itself and not external. In 113 machines investigated the power used was as follows:

Gasoline.....	18	Electric motor.....	1
Steam.....	93	Horses.....	1

As the largest number of machines in the territory were operated by steam power the figures just given do not indicate that steam-driven outfits are more subject to explosions than are other types. They do, however, discount the theory that explosions occurred only in machines operated by steam power.

**HOT BOXES.**

The frequent occurrence of hot boxes around the machine also was assigned as a cause for many of the explosions. It was asserted that the boxes were allowed to become hot and helped to set fire to the machine.

The investigators endeavored to obtain information relative to the presence of hot boxes, but the difficulties encountered along this line were increased by the fact that the average operator was not willing to admit that hot boxes occurred frequently in his machine. At the time of the investigation it was difficult to determine definitely whether a boxing had been melted by the fire or had been heated to the melting point before the fire started. During the conduct of the field investigations personal observation of machines while running indicated that a large number of boxings run hot all the time. In some cases the "oiler" could be seen carrying water from the engine and pouring it on the boxes. The results of 113 investigations based on statements of separator men can be summarized as follows:

No hot boxes.....	72	One to three each day.....	2
Occasional.....	33	One to two each day.....	1
One each day.....	5		

Although difficulty was encountered in obtaining data which were considered authentic, the investigations show conclusively that the presence of a hot box is not essential in order that an explosion may take place. This does not mean that a hot box may not be a contributory cause to an explosion if the heat generated is of sufficient intensity and so located as to cause ignition.

**DAMAGE TO SEPARATOR.**

The damage to the separators varied from very slight damage to total destruction. In cases where fire-fighting equipment had been provided the damage was much smaller than in the machines where no precautions had been taken. In 146 explosions and fires the results can be summarized as follows:

	No. cases.	Per cent.		No. cases.	Per cent.
Complete loss .....	40	27.4	Slight damage .....	20	13.7
Partial loss .....	49	33.6	No damage .....	37	25.3

The total damage reported for all machines was about \$60,000. In many cases after complete loss the owner was compelled to discontinue threshing for the season, and a serious situation was threatened unless some remedy was found.

**DAMAGE TO GRAIN.**

In almost all cases the flame from the explosion and fire was blown into the straw pile, and in many instances spread to the stacked grain and also to the unthreshed grain in the field. As a result sev-



FIG. 1.—THRESHING WHEAT NEAR MOSCOW, IDAHO, WITH 8 PER CENT SMUT (ESTIMATED) IN CROP.

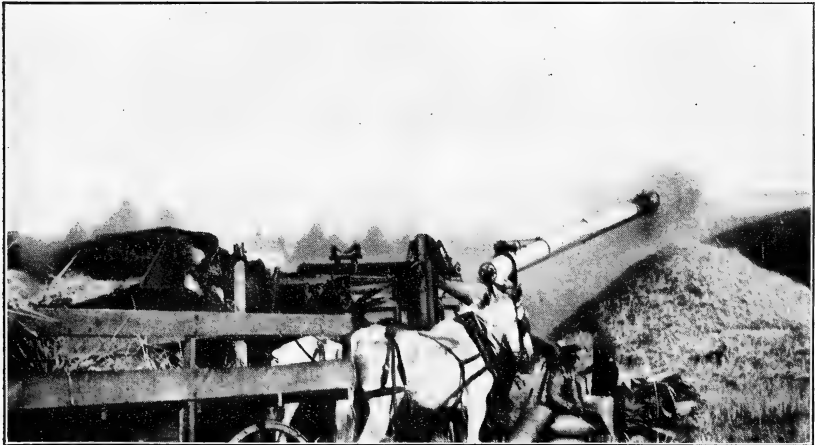

FIG. 2.—SAME MACHINE THRESHING WITH 14 PER CENT SMUT (ESTIMATED) IN CROP, SHOWING BLACKER SMUT-DUST CLOUD COMING FROM BLOWER PIPE.

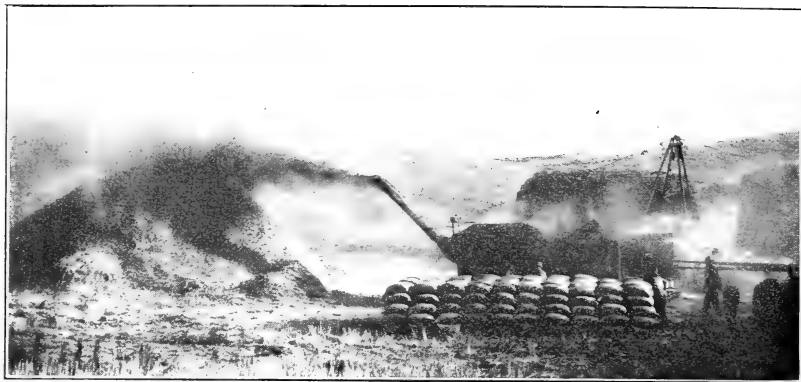

FIG. 1.—BLACK SMUT-DUST CLOUD COMING OUT OF BLOWER PIPE DURING THRESHING OF SMUTTY WHEAT IN EASTERN WASHINGTON.

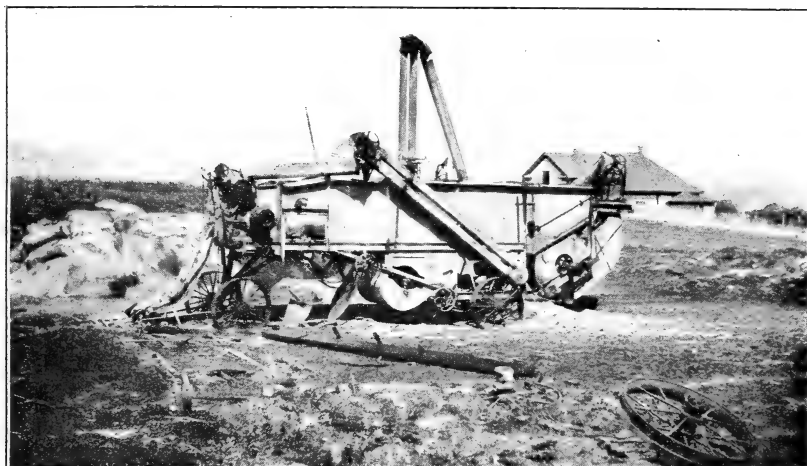

FIG. 2.—STEEL MACHINE BADLY DAMAGED BY SMUT EXPLOSION AND FIRE IN EASTERN WASHINGTON.



FIG. 3.—WOODEN MACHINE COMPLETELY DESTROYED BY SMUT EXPLOSION AND FIRE IN PACIFIC NORTHWEST.



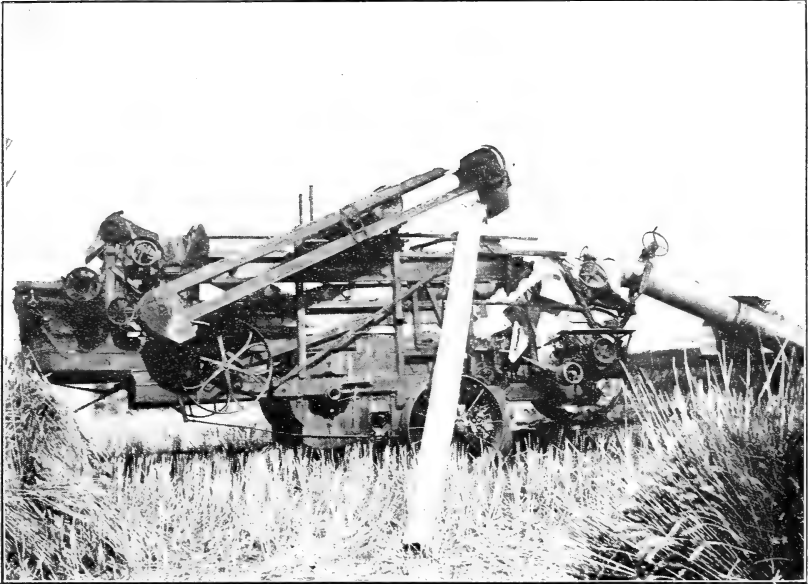

FIG. 1.—WOODEN MACHINE, AFTER EXPLOSION AND FIRE.

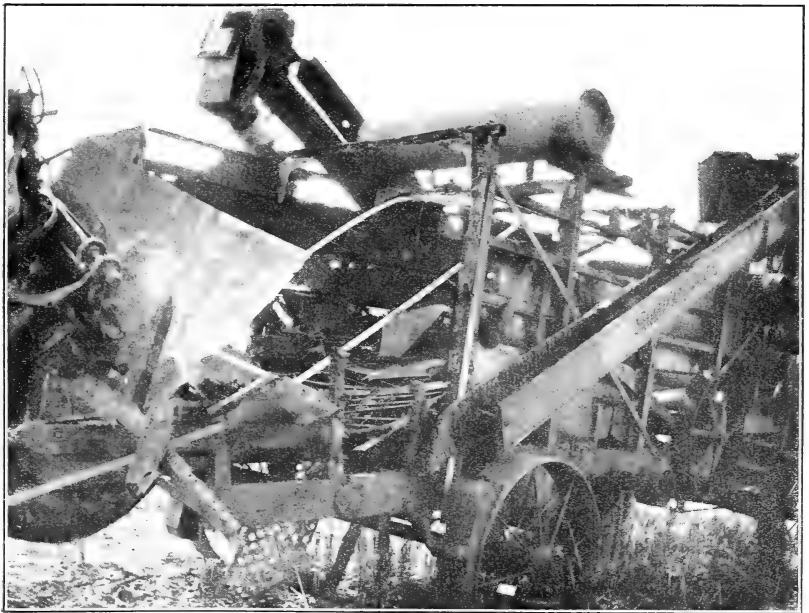

FIG. 2.—ANOTHER VIEW OF SAME MACHINE, SHOWING EXTENT OF DAMAGE.

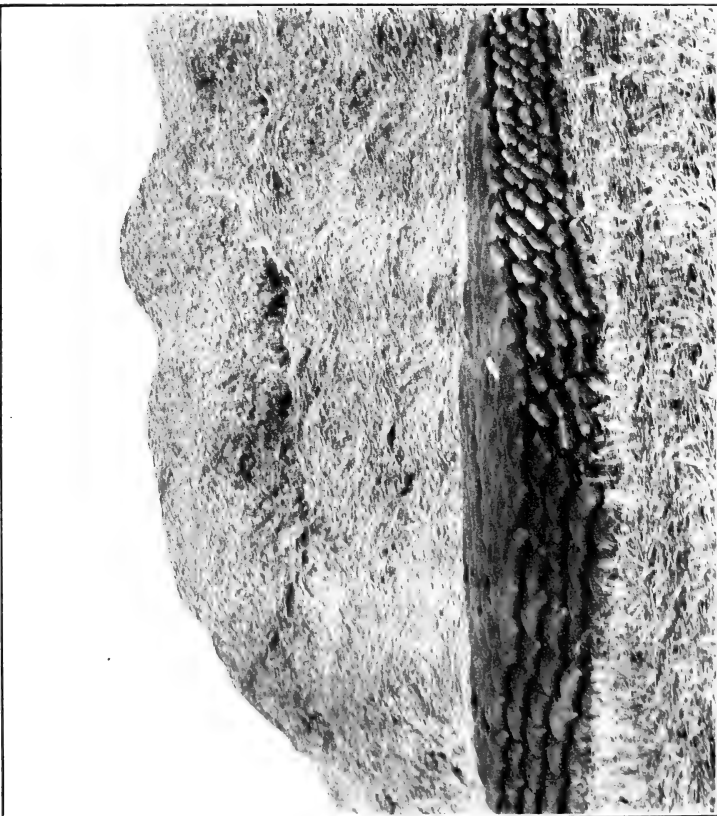

FIG. 1.—PILE OF 1,250 SACKS (3,000 BUSHELS) OF WHEAT THRESHED IN NORTHERN IDAHO. THE SACKS ARE PILED IN THE FIELD AND THEN HAULED TO GRAIN WAREHOUSE FOR MARKET.



FIG. 2.—INVESTIGATORS MEASURING DISCHARGES OF STATIC ELECTRICITY FROM STEEL MACHINE.

eral hundred acres of grain were destroyed. The grain loss in the fires investigated reached about \$50,000.

#### MACHINES WITH FIRE-FIGHTING EQUIPMENT.

A large number of the machines in which fires occurred were provided with some fire-fighting equipment, as is shown in the following summary:

	No. cases.	Per cent.		No. cases.	Per cent.
No fire-fighting equip- ment-----	28	24.8	Chemical extinguish- ers-----	29	25.6
Water, steam, etc-----	43	38.1	Water tanks-----	13	11.5

From this summary it will be seen that less than 25 per cent of the machines were not equipped with fire-fighting apparatus. Since the percentage of machines that suffered a total loss (27.4 per cent) is in about the same proportion, it is reasonable to conclude that the fire-fighting equipment was effective, especially so since in the majority of cases where the machines were totally destroyed no preventive means had been installed to check the progress of the fire and explosion.

### STATIC ELECTRICITY AS A CAUSE OF EXPLOSIONS.

#### THRESHING-MACHINE EXPLOSIONS.

It was evident from the beginning of the investigation that a large quantity of static electricity was generated during the operation of the separator. Workmen admitted that on certain days static electricity was noticeably present around the machines.

One case in which the owner thought the presence of static electricity was responsible occurred in Latah County, Idaho. This machine was new, having been operated but part of a day. It was completely destroyed as a result of the explosion. As the outfit was located 15 miles from a railroad and 4 miles from the county road there was no reason to suspect incendiarism. The crew was composed of neighbors, or men known to be reliable. There was 19 per cent smut (estimated by counting the smutted heads) in the crop. The weather was very hot and dry. After summarizing the evidence, the investigator concluded that it was clearly a case of smut explosion by electrostatic ignition.

A similar case occurred in Whitman County, Wash. The owner had experienced two fires, one in the evening and the other the following morning, neither of them causing much damage to the separator but destroying the surrounding grain in the field and the threshed grain in sacks. At the time of the occurrence the machine was threshing wheat with 31 per cent smut and was located 21 miles from the railroad and several miles from the county road.

The evidence available convinced the investigator that the explosion was due to ignition of smut dust by static electricity.

In another case the owner of a machine which was destroyed stated that he was standing at the engine and was looking directly at the cylinder at the time of the explosion. He could see the cylinder itself, as the feeding had stopped momentarily. He observed a long blue spark coincident with the explosion. In other investigations the men in charge of the machines stated that there were large quantities of static electricity present around the machine preceding the explosions.

In one case the owner of the machine stated that his machine was very heavily charged with static electricity on the morning of the explosion, to such an extent that it was not possible to touch any metal part without getting a shock. This condition had never been noticed on this particular machine before. The explosion was violent in nature and totally destroyed the machine.

#### MILL EXPLOSIONS.

Previous investigations relative to the causes of explosions in grain mills and elevators and similar plants indicated that static electricity was a possible factor in the production of dust explosions.

In September, 1913, at the time investigations were being conducted in cooperation with the Millers' Committee of Buffalo, N. Y., two slight explosions occurred on a dry, frosty morning in early fall, in two separate plants in western New York, at a time when the feed had been shut off from certain grinding machines. Both occurrences took place a considerable time after the stream of grain had stopped entering the machines. The possibility of static electricity being generated by the operation of the revolving plates of the machine suggested itself in a very preliminary way at the time of these explosions, and a confidential report was prepared and presented at the time to the Millers' Committee. Although up to that time no record could be found that experiments had been conducted to determine whether cereal dusts could be ignited in this manner, it was found by experiment that sufficient static electricity could be generated by the friction of a very small pulley and belt to ignite natural gas readily. It was learned at this time that a milling company in the South, engaged in grinding cottonseed cake into meal, after experiencing a series of explosions, had prevented a repetition of these occurrences by grounding the machine by means of a wire connected to a rod driven into the ground near by.<sup>1</sup> This seemed to confirm

<sup>1</sup> Preliminary Report on the Explosibility of Grain Dusts. Cooperative Investigation by Millers' Committee, Buffalo, N. Y., under the direction of Dr. George A. Hulett, Chief Chemist, U. S. Bureau of Mines. By David J. Price and Harold H. Brown. Pittsburgh, 1914.

the original theory and indicated the value of a grounding device of this kind.

The possibility of static electricity as a source of cereal dust ignition was very clearly established by an explosion in the dextrine department of a starch factory in one of the Eastern States (in September, 1914). The origin of this explosion was traced to the generation of static electricity by friction of particles of dextrine on an 80-mesh brass gauze surrounding a revolving reel. This reel was revolving at the rate of only 16 revolutions per minute when the explosion occurred.

At the time of the explosion this reel was grounded to an overhead sprinkling system. During the investigation which followed, however, it was found that the connection was made from the journal box, and that a heavy film of fresh oil surrounded the shaft. This was thought to have served to insulate the shaft and allow the static electricity to accumulate within the reel until there was sufficient charge to ignite the dust.

An English scientist has determined that if a cloud of dust is blown against an insulated conductor (a wire, for instance) the wire becomes charged with electricity, and under certain conditions may become so highly charged as to give off sparks.<sup>1</sup>

## EXPERIMENTAL FIELD AND LABORATORY WORK.

### METHODS OF GROUNDING MACHINES IN EXPERIMENTAL WORK.

From results that had previously been obtained by grounding machines effectively in various branches of the milling industry and also by some machine operators in the Northwest, it was decided to conduct experimental work along this line with the grain separators, in an attempt to carry off any static electricity that might be generated during the operation of the machine.

The experimental work in developing a satisfactory grounding device was conducted along three distinct lines, as follows:

1. Separately grounding each part, either directly or through its bearing.
2. Connecting wires from all moving parts to one wire and grounding that wire.
3. Wiring all moving parts to some metallic portion of the separator of sufficient magnitude to act as a ground.

### DESCRIPTION OF VARIOUS METHODS.

*First method.*—The first method was perhaps the most common among the thresher men who were inclined to accept the theory that

<sup>1</sup> Philosophical Magazine, London, 6 (1913), p. 481-494. "On the Electrification Associated with Dust Clouds," by W. A. Douglass Rudge, Professor of Physics, University College, Bloemfontein.

static electricity was responsible for the smut dust ignition. The method usually adopted was to connect a No. 12 or 14 weatherproof copper wire to the journal box of the cylinder shaft and to an iron rod driven into the ground, and to make similar connection with the bearing of the stacker fan.

The arrangement was identical with the grounding device installed in connection with the dextrine reel (already referred to on p. 11) in an eastern plant where an explosion occurred. The film of oil existing between a shaft and its bearing may, and in the opinion of many does, act as an insulation, and thus render the method just described inefficient. When this was explained to the men in the field, many of them decided not to depend upon grounding from the bearings but to install a properly grounded direct copper brush contact to each shaft as recommended by the investigators.

In a number of cases the owners were desirous of having the investigators equip their machines to conform to the ideas advanced, and about 15 machines were so wired. It is of interest to note that no explosion or fire occurred in any machine grounded in this manner, while in one case an outfit not so equipped had two fires.

*Second method.*—The second method was the one which the investigators generally advocated, and was readily accepted by the mechanics and experienced thresher men, for it provides a double security. All moving parts were connected with each other and to a common wire, thereby destroying any difference of potential existing within the machine. This common wire was thoroughly grounded to relieve the machine of any surplus charge that might accumulate in it. About 10 machines were wired in this manner, consisting of a direct brush contact to the revolving shafts by means of a stiff strip or bar of copper. These machines, although located in parts of the territory where explosions and fires were most frequent, had neither an explosion nor a fire after being so equipped.

*Third method.*—The third method, that of grounding the moving parts on some heavy metallic part of the frame, was based on the theory that if the difference of potential between parts could be destroyed there would be no tendency for sparking between moving shafts and other metal parts. Several machines were wired in this manner during the season and all finished threshing without experiencing any fires or explosions. Field tests with electrical measuring instruments, however, did not show the complete absence of electricity in these cases, as was found in the other systems of wiring.

#### BLOWER SYSTEMS.

The possibility of removing the dust from the vicinity of the cylinder by means of a fan or blower located on top of the separator

suggested itself at the beginning of the study. The department, early in 1915, took this matter up with various representative manufacturers with a view to observing the efficiency of such an installation on threshing machines during operating conditions. The investigators collected information pertaining to the efficiency of such installations of this nature as were working in the field.

In one case a machine equipped with a blower system of this kind threshed 27 days in 1914 and 20 days in 1915. During this time only one flash occurred in the dust pipe, but this did not cause a fire.

The blower system consisted of two 15-inch fans mounted on the frame of the separator below the cylinder and a 20-inch suction fan mounted on the top of the separator. These fans were so arranged that the draft passed up and around the cylinder in the direction of the travel of the grain and straw. The opening to the suction fan was 4 inches in width and extended across the separator. In addition to preventing the formation of an explosive mixture of dust and air, this arrangement had an additional value, according to the owner, in that it cleaned the grain during the threshing to such an extent that he was enabled to get a better price for it. The dust collected by this system was blown through a special 10-inch pipe to the straw stack.

In another case a single suction fan was located beyond the cylinder on the opposite side from the main drive belt. In two cases where fire occurred the fan drew the fire out of the machine before any damage was done. The discharge was so located that the fire did not reach the straw pile or the standing grain.

One of the machines operating in a section of the territory where explosions were very frequent had two fans drawing dust from the ends and above the cylinder. In this machine, however, the arrangement was such that there was in the system a large square corner where smut, chaff, and dirt collected, thus defeating the true purpose of the fans.

#### SPRINKLER SYSTEMS.

In addition to developing an efficient grounding system to remove the static electricity generated during the operation of the machines, and in addition to conducting experiments with blower systems, the investigators endeavored to determine the relative efficiency of types of sprinkler systems and fire extinguishers in use. It was found that there were many different types and patterns of sprinkler systems in general use throughout the territory, but they were all included practically in three different classes:

1. The chemical fire extinguisher.
2. Water with (a) air pressure, (b) steam pump compression.
3. Hose from boiler to separator.

**CHEMICAL FIRE EXTINGUISHERS.**

The chemical extinguishers in use were arranged to be tripped by hand. They consisted of a tank containing water charged with bicarbonate of soda and a bottle containing sulphuric acid. The tripping device either upset the bottle or liberated a hammer that broke it. The extinguishers in use in the field worked with varying degrees of success.

**WATER UNDER PRESSURE.**

A number of separators were equipped with water tanks that could be pumped to 100 pounds pressure by a special air pump and were provided with a system of piping from the tank to the separator much the same as was the chemical extinguisher. The results obtained did not appear to be satisfactory, possibly due to the fact that as soon as some of the water had sprayed out the pressure dropped so rapidly that there was not sufficient pressure remaining to be effective. However, a number of machines were saved from total destruction by using this type of extinguisher.

One machine was equipped with a 40-gallon water tank on top of the separator connected to the engine pump which maintained a pressure of 70 pounds. In case of fire, by the pulling of a wire, the pipes from the tank were opened and the water carried to perforated pipes in the separator. As no fires occurred in this machine the tank did not receive a thorough trial.

**STEAM LINE FROM BOILER TO SEPARATOR.**

Steam or water hose from the engine boiler to the separator was used in many cases with satisfactory results. Its popularity was due to the comparative cheapness of the system (about \$50 to \$75) and also to the success attributed to it by the men who had used it. Best results were obtained when regular steam hose was connected to a point on the boiler below the water line. When a valve was opened at the boiler a pressure of steam and water was obtained which usually was successful in extinguishing the fire.

Where it was difficult to secure steam hose and it was not considered safe to use ordinary rubber hose the line was composed of steam pipe. This made a much more clumsy installation, but it worked successfully when necessary swinging joints were properly installed.

**FURTHER EXPERIMENTAL WORK.**

In addition to the investigations made in the field based on actual explosions and fires an attempt was made to study in the field or in the laboratory the following:



1. Prevalence and distribution of static electricity in and about the separator.
2. Inflammability of smut dust.
3. Effect of introducing foreign material, accidentally or maliciously, into the separator.

#### MEASUREMENT OF DISCHARGES OF STATIC ELECTRICITY.

Both steel and wooden separators were tested while threshing both smutty and smut-free wheat and also oats. The common plan of procedure was to establish a good reliable "ground" by driving an iron rod deep into the earth, pouring water around it, and connecting one lead from a galvanometer to this rod. The other lead from the galvanometer was loose and was touched in turn to cylinder shaft, frame, blower, and all moving parts.

On all machines tested strong discharges were obtained from almost every part of the machine to the ground, but in many cases the strongest appeared to be from the front wheels to the ground. Strong discharges were also obtained between the cylinder shaft and concaves, and slight ones between a moving and a stationary metallic part, and between any two moving parts. The galvanometer used in the tests was the ordinary two-coil instrument showing deflection and direction but not magnitude of the current.

#### FIELD EXPERIMENTS.

At the close of the threshing season three day tests were run on a donated separator in the field in northern Idaho, under as nearly actual threshing conditions as could be secured at that time. As it was impossible to obtain unthreshed smutty wheat, it was necessary to make use of straw mixed with loose smut secured from a local mill. At the time of the tests the temperature was at least 50 degrees below that prevailing during the threshing season, and the weather was unusually damp. Because of the conditions existing, the results of these tests can not be considered conclusive, but they tend to confirm the deductions made from the investigations in the field during the threshing season.

#### STATIC ELECTRICITY AND ELECTRIFICATION OF SMUT DUST.

The experimental work carried on during the investigations proved conclusively that, under favorable atmospheric conditions, static electricity is present on all types of machines. In the Pacific Northwest humidity conditions during the entire threshing season are favorable for the production of static electricity. The air as a rule is very hot and dry, with the humidity on certain days as low as 7 per cent, the average being about 17 per cent for the middle of the day.

It appears that the largest discharges of static electricity were obtained from the steel machines. Larger deflections were also obtained in threshing wheat than in threshing oats. The fires and explosions occur as a rule while fall wheat is being threshed and very rarely occur during the threshing of spring wheat. The discharge from the machines while smutty wheat is being threshed is more noticeable than when clean wheat is going through the machine. Fall wheat as a rule contains much more smut than does spring wheat. The theory that the small particles of smut easily become electrified when the kernels are broken up by the cylinder teeth and that each particle becomes charged with static electricity has been advanced as a possible explanation of the fact that the largest discharges seem to occur when smutty wheat is being threshed. The theory is tentative and can be proved only by experimental work to determine in what manner the static electricity is generated.

#### INFLAMMABILITY OF SMUT DUST.

In addition to the experimental work carried on in the field during the progress of the investigations, a series of laboratory experiments to determine the inflammability of smut dust was conducted by J. C. Woodson, assistant agricultural engineer, at the University of Idaho. This work was done in the laboratories of the Department of Physics, and advice and assistance were obtained from Prof. Angell.

The laboratory experiments were by no means conclusive and not so extensive as work already planned for the future, but were merely preliminary in nature. However, they were sufficient to indicate that smut dust is highly inflammable and can be ignited by an electrostatic spark.

#### FOREIGN MATERIAL ENTERING MACHINE.

In many cases the investigations indicate that foreign material consisting of gravel, flint, metal, etc., entering the machines and the rubbing and friction of cylinder teeth produced sparks which may possibly have ignited the dust. In one case both cylinder and concave teeth were found bent forward after the explosion and showed signs of rubbing.

In some cases the explosions occurred during the clean-up, which suggested to the owner the possibility of sparks being produced by foreign material entering the machine. This matter can be decided only by experimental work to establish clearly the relation between the suspended dust cloud and sparks produced in this manner. This cause has been assigned to dust explosions in grain mills and industrial plants, and is at the present time receiving attention.



FIG. 1.—COMBINE MACHINE AFTER SMUT EXPLOSION AND FIRE, IN EASTERN WASHINGTON.

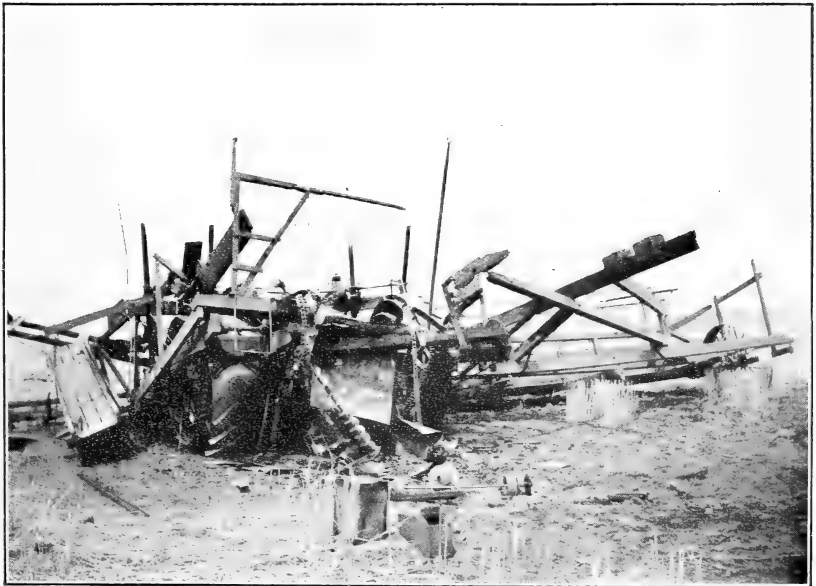

FIG. 2.—ANOTHER VIEW OF SAME MACHINE.

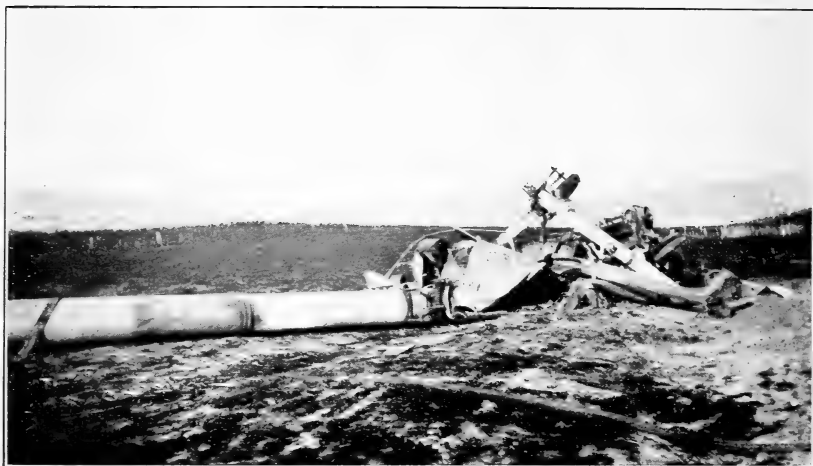

FIG. 1.—REMAINS OF THRESHING OUTFIT AFTER SMUT EXPLOSION AND FIRE, NEAR PULLMAN, WASH.

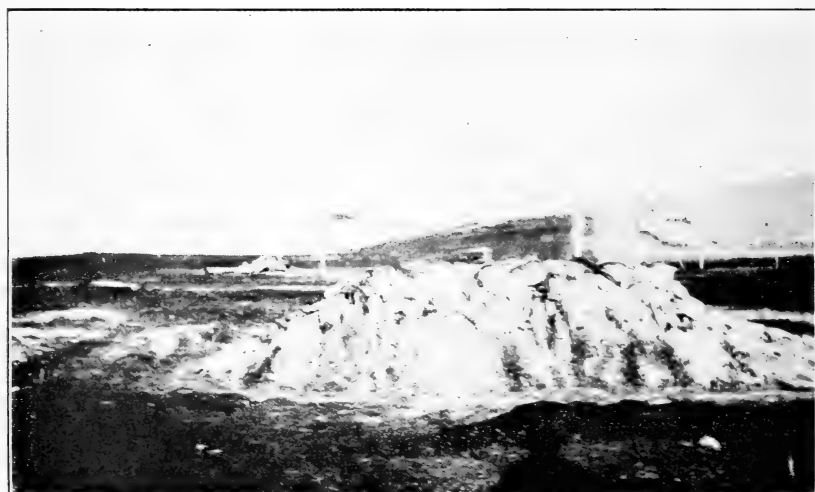

FIG. 2.—PILE OF 750 SACKS (1,875 BUSHEL) OF WHEAT DESTROYED BY FIRE FROM EXPLOSION IN ABOVE MACHINE.

**EXPERIMENTS WITH MATCHES AND ACIDS.**

Experiments also were conducted to determine the resulting action of various acids on matches. A current opinion existed that many grain fires in the fields were caused in this manner. Matches were tied about the neck of a small vial containing sulphuric acid and also one containing nitric acid. A cork about one-eighth of an inch thick was placed in the mouth, and the bottles were inverted, allowing the acids to eat through the corks and come in contact with the match heads. These acids were tried with eight different varieties of matches, but failed to ignite the matches in a single case. The acids experienced no difficulty in eating out the corks, the nitric acid doing so in 40 to 60 minutes and the sulphuric acid requiring 6 to 10 hours.

**NATURE OF DUST EXPLOSIONS.****THEORY OF DUST EXPLOSIONS.**

The theory of dust explosions, although not entirely new, has not been understood clearly by a number of people, who are, therefore, at a loss to know in what manner these explosions originate and the circumstances necessary for their occurrence. That dust itself can be made to explode without the presence of inflammable gases has seemed incredible.

Experimental work has shown that the dust produced during the handling of grain can be ignited under certain conditions, and will propagate a flame with explosive violence. It must not be concluded that grain dusts will ignite spontaneously. On the contrary there must be some outside source of heat. This source may be very small, as a heated coil of wire or an electric spark as used in the experimental work, or it may be larger, as a flame which may have a lower temperature but a larger heating surface.

The following illustration may simplify the explanation of the nature of dust explosions. We might try for some time to burn a block of wood with a lighted match. If we take a knife and chip the block the shavings will ignite more quickly. We might make excelsior and find it would ignite still more rapidly, and then continue by gradual reduction to a degree of fineness until dust is produced, when it is found that the mass will burn rapidly when in suspension and diffused in the air. The rate of burning is so rapid that a violent explosion may result.

Many theories have been advanced as to the conditions under which dust explosions are produced and the amount of dust in suspension necessary to propagate the explosion. The predominating factors which determine the inflammability of a dust and the action of a dust explosion have not been definitely determined. It is generally

agreed, however, that the dust must be fine and dry and in a state of suspension in the atmosphere, so that upon being brought in contact with sufficient heat or flame an ignition is caused. It generally is conceded that there must be a proper proportion in diffusion in order for the explosive mixture of dust and air to ignite with sufficient force to propagate an explosion.

The conditions under which these thresher fires and explosions occur appear somewhat similar to those with other cereal dusts. During the threshing process the smut, which is a form of very fine, dry dust, is thrown into suspension in the air and forms a dangerously explosive mixture, which readily would produce an explosion or fire if ignited. The mixture of smut dust and air may have limits of explosibility, and it is quite possible at times to have too much dust present, and at other times not sufficient, for an ignition. For this reason explosions may occur at a given time and under certain conditions and not occur at other times or under different conditions.

#### AMOUNT OF DUST REQUIRED FOR EXPLOSION.

Explosions have been produced at the Pittsburgh Testing Station of the United States Bureau of Mines when there was only 0.032 ounce of coal dust suspended in each cubic foot of air, or 1 pound in 500 cubic feet. In order to produce complete combustion it takes all of the oxygen in 1 cubic foot of air to burn completely 0.12 ounce of the coal dust used.<sup>1</sup> Preliminary experiments have shown that smut dust is highly inflammable, and also that many of the cereal dusts have relatively a lower ignition temperature and produce higher pressures than coal dusts. It might be concluded that the explosive limits of cereal dusts would be lower than those of the coal dusts.

In some of the thresher explosions at least two distinct reports were heard; the first being sharp and quick and the second resembling a loud roar and lasting longer than the first and accompanied by more flame. An explosive mixture consisting of sufficient quantity of smut dust in suspension, ignited by sufficient source, would no doubt cause the sharp report usually heard first. This original ignition, possibly only an inflammation, might produce sufficient concussion to shake the dust that had settled on various parts of the separator into suspension in the air, thus forming an additional explosive mixture. The heat or flame from the first small puff or inflammation would cause an ignition of this newly formed mixture, and the explosion would propagate through the entire dust zone. This may serve to explain the loud rumbling sound sometimes heard, accompanied by a large body of flame causing extensive damage.

<sup>1</sup> U. S. Dept. Interior, Bureau of Mines, Miners' Circular No. 3, Coal-Dust Explosions, (1911), p. 7. Geo. S. Rice.

## METHODS DEVELOPED FOR PREVENTING EXPLOSIONS OR EXTINGUISHING FIRES.

### GROUNDING THE SEPARATOR.

As a result of the investigations carried on by the department during the past season, it is believed that a complete system of electrical connection from all of the moving parts to a common wire, and a thorough grounding of this common wire, will prevent a large percentage of the fires that are due to the presence of static electricity and an explosive mixture of smut dust and air. There are, of course, several ways in which this wiring may be installed, and the system will vary somewhat with the type of machine.

One arrangement that is considered by the engineers of the department to provide as nearly complete protection from ignition by static electricity as any other is illustrated in Plate VIII. An inspection of this illustration will show that the common wire or conductor, A, is grounded through a rod, B, which should be driven at least 3 feet into the ground and kept well moistened. There is a connection, C, to this conductor from the shaft of the cylinder through the copper brush D. This brush is in contact with the shaft itself and not with the bearing. This construction is used to avoid any possibility of insulation due to the film of oil between the shaft and the bearing. The shakers are connected to the lead E. The lead F, which extends over the entire sieve, connects that piece to the common wire. The lead G connects the metal casing of the stacker fan to the wire A. The investigations in the field indicate that the moving parts just described are the ones on which static electricity is likely to be generated. These investigations also show that there were occasional collections of static electricity on the metal casing. For this reason that connection has been made. The common lead and its main branches are of No. 14 bare copper wire. The connections, particularly to the moving points, should be of flexible insulated wire coiled a sufficient number of turns to permit full flexibility. The wires should be attached to the framework of wooden machines by staples, which should be of the insulated type, or there should be a cushion of rubber or other material between the staple and the wire, as otherwise the wire is likely to snap at that point and break the circuit.

### SUCTION FAN.

As it is necessary, in order for an explosion to occur, to have present in the separator an explosive mixture of dust and air, the arrangement illustrated in Plate IX is suggested as a means for preventing the formation of such an explosive mixture. The arrangement consists of attaching to the top of the separator, and near the cylinder, a suction fan, A. This fan exhausts from above the cylin-

der as shown at B, and also from beneath the fan as shown at C, there being another connection on the opposite side of the fan from C.

The method of installing the fan necessarily will vary with the type of separator. The object is to remove the dust from near the cylinder. The fan should be arranged to accomplish this.

There is no way of demonstrating by experiment that either of these methods actually prevents explosions, but the fact that no such occurrences took place in the case of separators properly equipped with either one of these devices, while explosions and fires were constantly occurring in machines located near them and not so equipped, warrants the belief that the devices proved effective in preventing explosions and consequent fires.

#### AUTOMATIC FIRE EXTINGUISHER.

Experiments conducted in the field during the threshing season, and since that time on the Arlington Experimental Farm at Arlington, Va., show that, under ordinary conditions, it is very difficult to secure a fire in a separator by the introduction of matches or other foreign materials. This has been particularly the case in experiments conducted on the Arlington Experimental Farm, in which, owing to the lack of smut dust and proper atmospheric conditions, it was impossible to secure an explosive mixture in the separator. In order to set fire to the separator in these experiments, it was necessary to introduce a flame and, to secure positive results, use was made of waste and rags soaked in gasoline and ignited by a flame from the outside. Bundles of matches fed in with the straw did not cause a fire.

However, since there is a possibility that fire will be caused under certain conditions by the entrance into the separator of foreign materials, and since it was impossible to prove positively that either grounding the separator or the use of the suction fan was a sure preventive of fires, it was decided to design an automatic fire extinguisher that would afford protection irrespective of the cause of the fire or explosion. Such a device is shown in Plates X and XI. It consists of the following parts: Tank A mounted on top of the separator; within the tank a bottle, C, containing sulphuric acid; a discharge pipe, H; a tripping mechanism composed of operating levers G and main tripping lever L; a trigger, N; discharge nozzles, I; and fuses, F, mounted in a wire line. In the discharge line between the tank and the separator may be mounted a three-way valve, P, from which there may be led, as at R, a hose connection for extinguishing outside fires. The tank is filled with water containing soda. The operation of the device is as follows:

The presence of sufficient heat within the separator will melt one of the fuses F. This breaks the wire line, releasing the trigger which



frees the tripping mechanism, causing a hammer within the tank to strike a blow sufficient to break the bottle. The discharge of the sulphuric acid into the water containing soda causes the formation of carbon dioxide, which generates sufficient pressure to force the water through the discharge pipe and the nozzles to all the crevices of the separator.

This extinguisher was designed in the Office of Public Roads and Rural Engineering, after the completion of the work in the field, by Elmer Johnson, assistant mechanical engineer, and J. C. Woodson, assistant agricultural engineer. A full-sized working model was constructed and has been tried out in the explosion galleries of the Bureau of Mines at Pittsburgh, Pa., and since that time on four different types of separators at the Arlington Experimental Farm. A total of 27 tests with this extinguisher have been made, and in no case did it fail to operate automatically and properly and to extinguish the fire before any damage was done.

The locations of the fuses F shown in the sketch are those suitable for the particular machine shown in the drawing. The locations, however, will vary with each machine, and must be selected so that the fuses are sure to be reached by the flame or the heat, but not so placed that the wire connecting them is likely to be broken by the straw or by the moving parts of the separator.

The location of the nozzles depends upon the construction of the machine, but the following points should be observed:

Locate one nozzle directly above the cylinder, if possible; if not, place it so that the beater will help diffuse the spray from that nozzle.

Run the pipe line along underneath the roof of the separator, with the nozzles pointing downward.

Install a sufficient number of nozzles along this line, and so locate them that every chamber in the separator is thoroughly served by a nozzle.

Particular pains should be taken to serve dead air spaces, as it is in these that dust is likely to accumulate.

As the stacker end of the machine is less likely to contain any closed chambers, it is probable that, in most types of machines, the nozzles at this end may be 30 inches or more apart.

The last nozzle along the pipe line and within the separator should be just above the end of the shakers.

One nozzle may be located in the wind stacker by means of a flexible connection from the pipe line.

The tripping mechanism of this extinguisher is so arranged that it may be released by hand, and also arranged so that it can be locked while on the road. Two pounds pull is sufficient to release it, but it has proved to be sufficiently rigid to withstand the jar and

vibration due to the threshing. In no case has it released itself prematurely.

It has been suggested that, when not in use on the separator, this device can be mounted on running gears and used for general fire protection about the farm.

A special nozzle was designed for use with this extinguisher. It is shown in detail in figures 2, Plate XI.

Large-scale drawings of these three devices are on file in the Office of Public Roads and Rural Engineering, and may be secured on application by manufacturers, owners, or operators of threshing outfits who seriously contemplate the installation of one or more of them.

#### SPECIAL ACKNOWLEDGMENTS.

In connection with carrying on the work described in this bulletin, special acknowledgment is due to Dr. H. H. Brown, assistant chemist, Bureau of Chemistry, and Elmer Johnson, assistant mechanical engineer, Office of Public Roads and Rural Engineering, for assistance rendered in conducting experiments in the laboratory to determine the inflammability of smut dust, in designing the apparatus described herein, and in conducting tests at the Bureau of Mines' galleries at Pittsburgh, Pa., and with grain separators at Arlington Experimental Farm.

Acknowledgment is also due to the Grain Standardization Laboratory, Portland, Oreg., for assistance in investigations and in collection of grain samples; to the Bureau of Plant Industry for assistance in experimental work at the Arlington Farm; and to the Bureau of Mines for use of the explosion galleries and laboratories at Pittsburgh, Pa.

ADDITIONAL COPIES  
OF THIS PUBLICATION MAY BE PROCURED FROM  
THE SUPERINTENDENT OF DOCUMENTS  
GOVERNMENT PRINTING OFFICE  
WASHINGTON, D. C.  
AT  
10 CENTS PER COPY



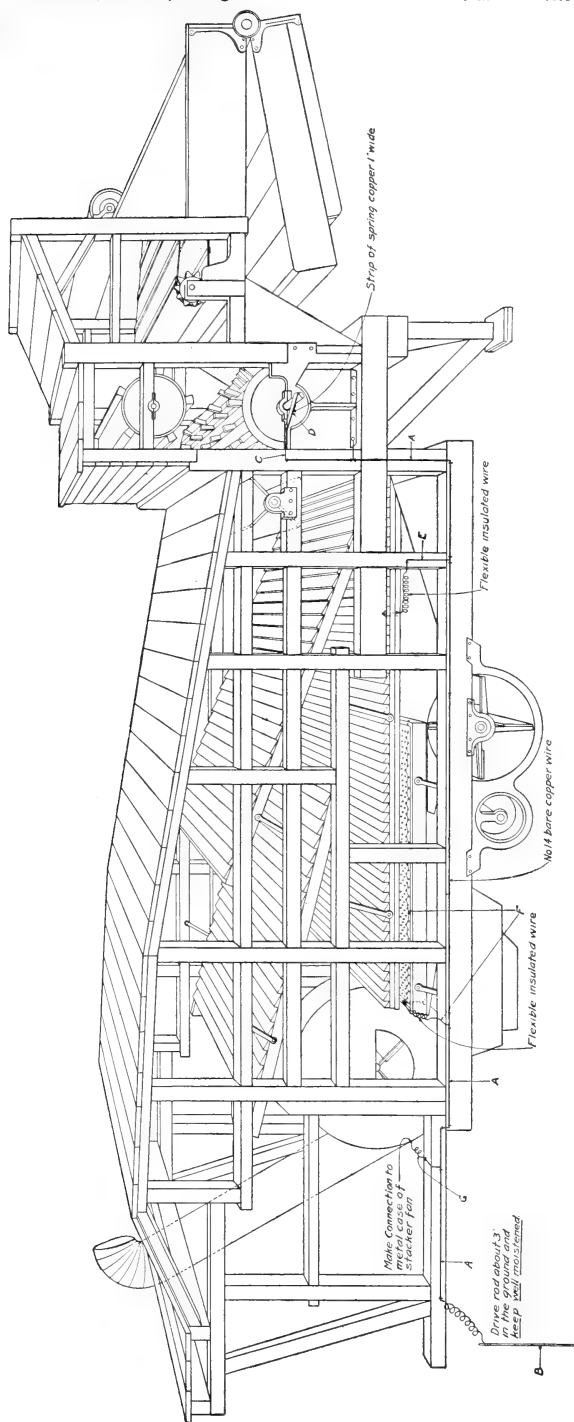

WIRING SYSTEM FOR GRAIN SEPARATORS.

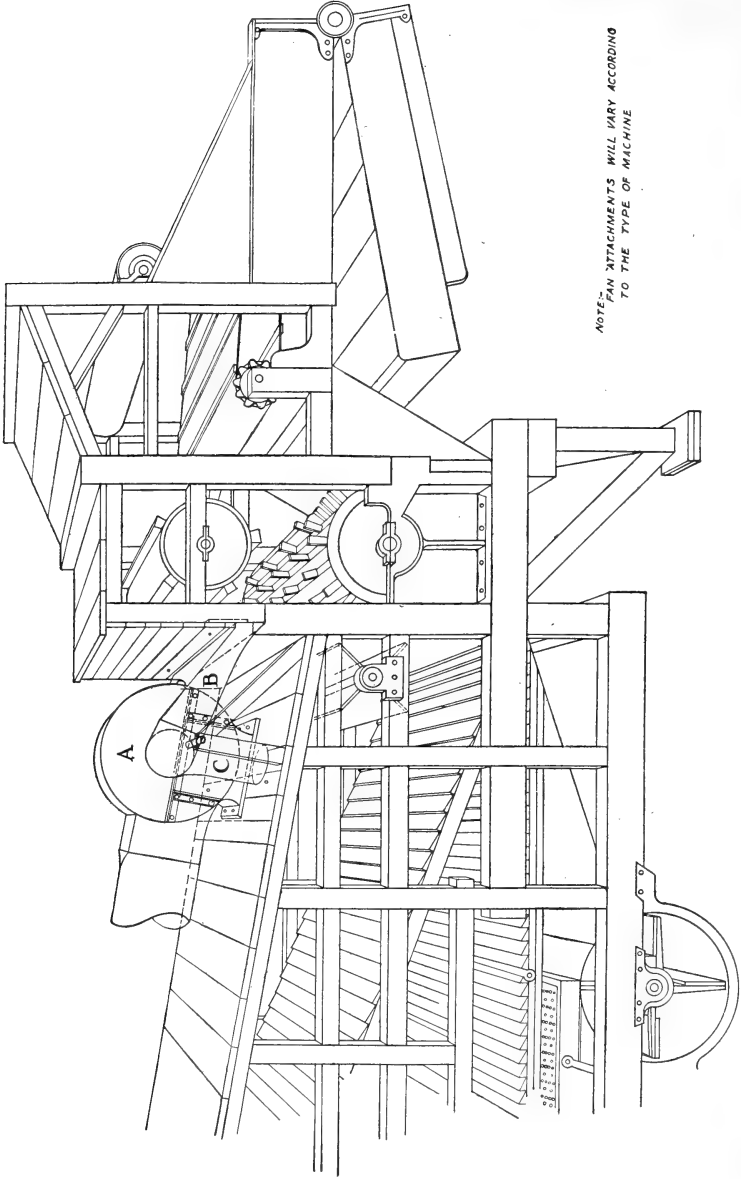

NOTE: FAN ATTACHMENTS WILL VARY ACCORDING TO THE TYPE OF MACHINE

SUCTION FAN INSTALLATION.

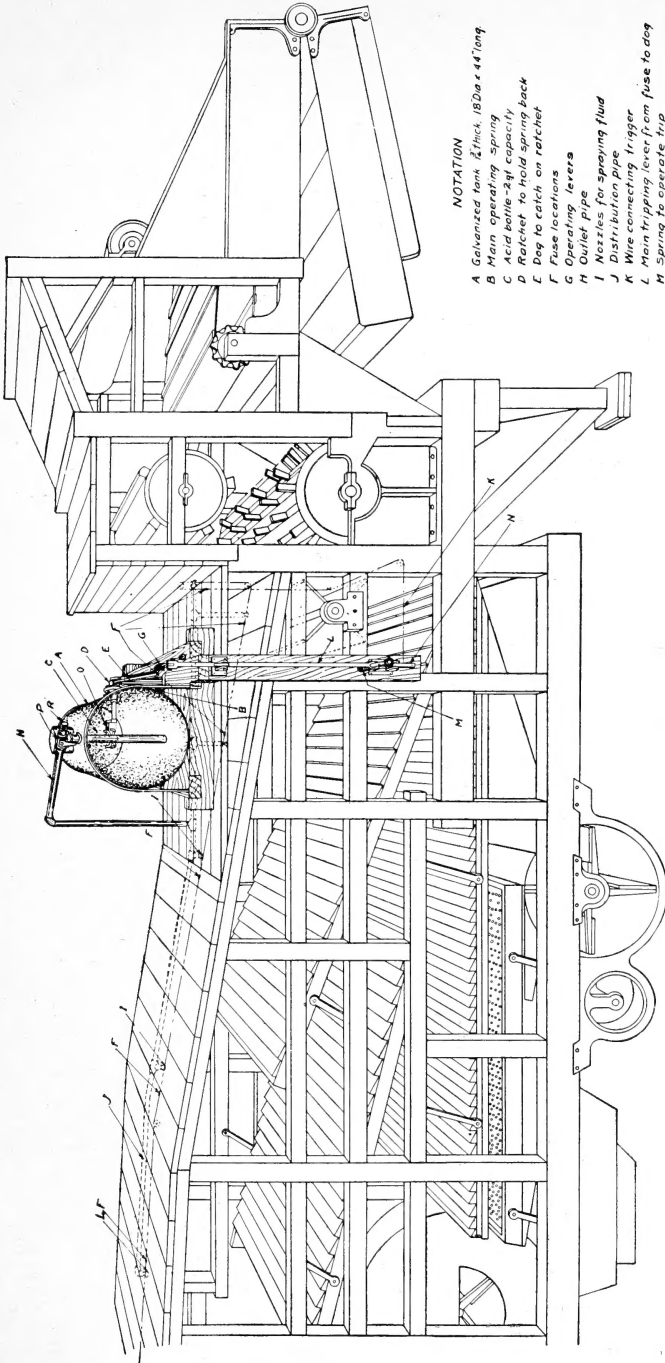

NOTATION

- A Galvanized tank, 1/2 thick, 18 1/2 in. x 4 1/2 in. long
- B Main operating spring
- C Acid bottle - 2 qt. capacity
- D Ratchet to hold spring back
- E Key to catch on ratchet
- F Fuse locations
- G Operating levers
- H Outlet pipe
- I Nozzle, for spraying fluid
- J Distributors
- K Wire connecting pipe trigger
- L Main tripping lever from fuse to key
- M Spring to hold down trip
- N Trigger to hold down trip
- O Hammer for breaking bottle
- P Three-way valve
- R Long pipe nipple for hose connection

AUTOMATIC FIRE EXTINGUISHER.

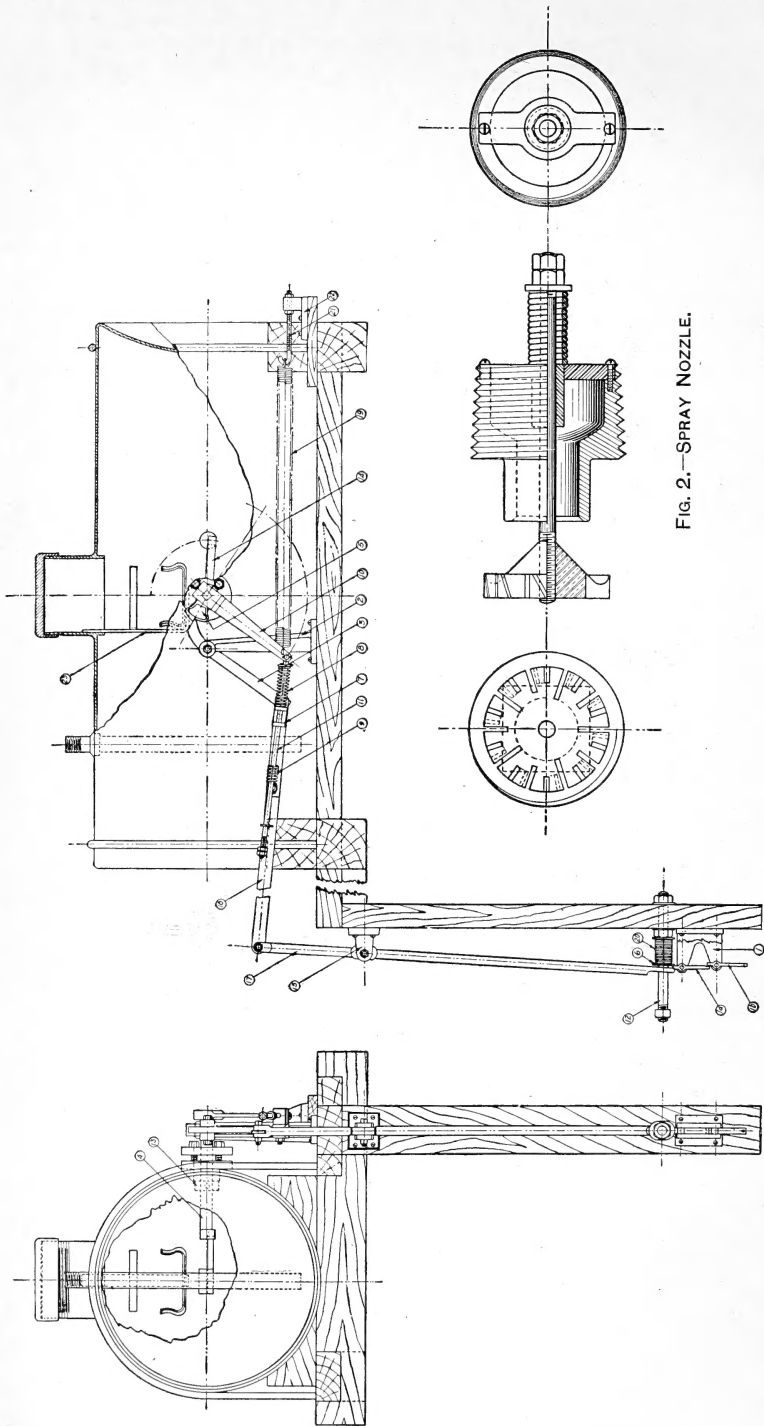

FIG. 2.—SPRAY NOZZLE.

FIG. 1.—DETAIL OF AUTOMATIC FIRE EXTINGUISHER.



