



UNIVERSITY OF ILLINOIS
LIBRARY

Class	Book	Volume
537.05	EA	30

REMOTE STORAGE

Mr10-20M



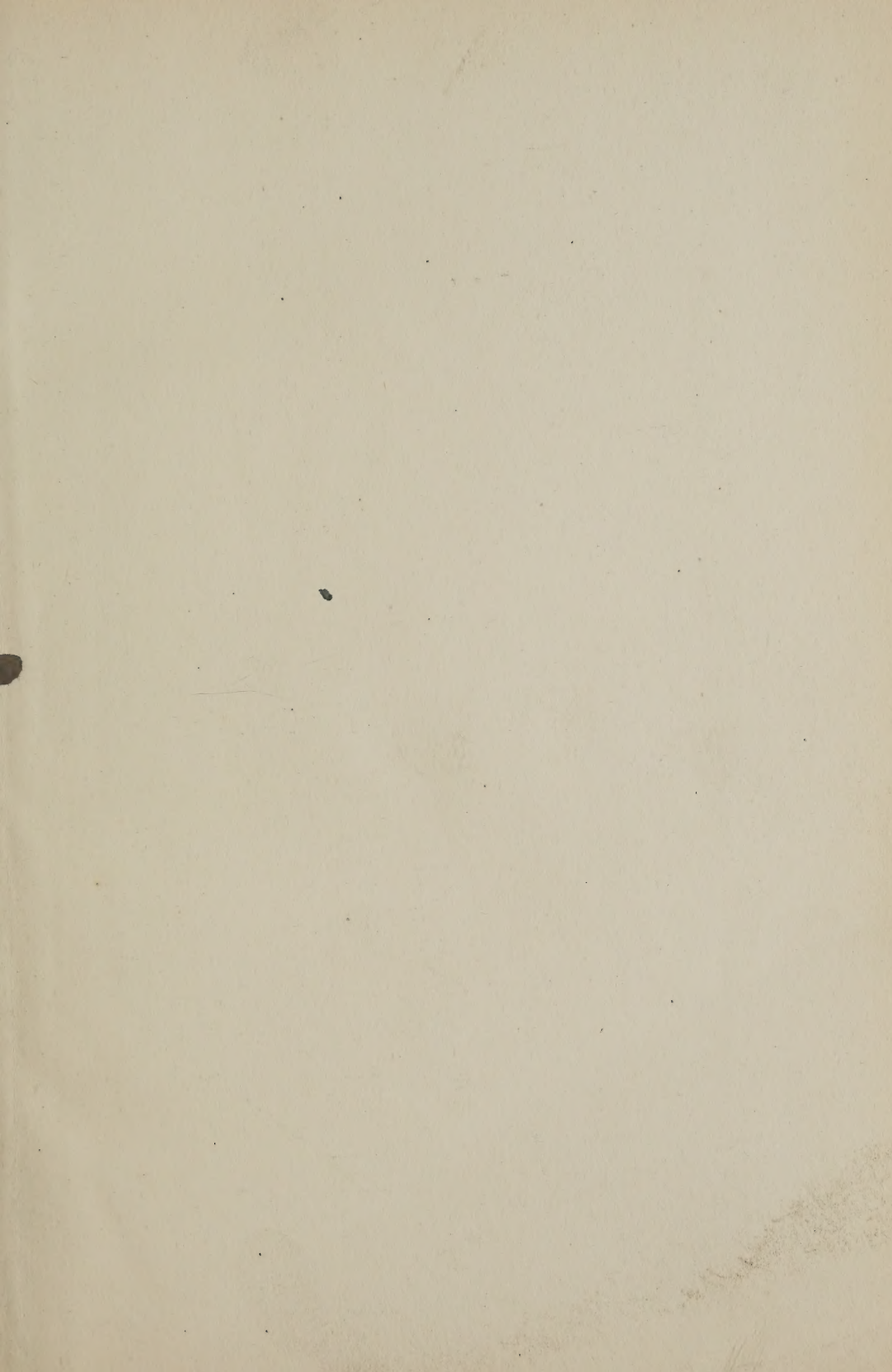

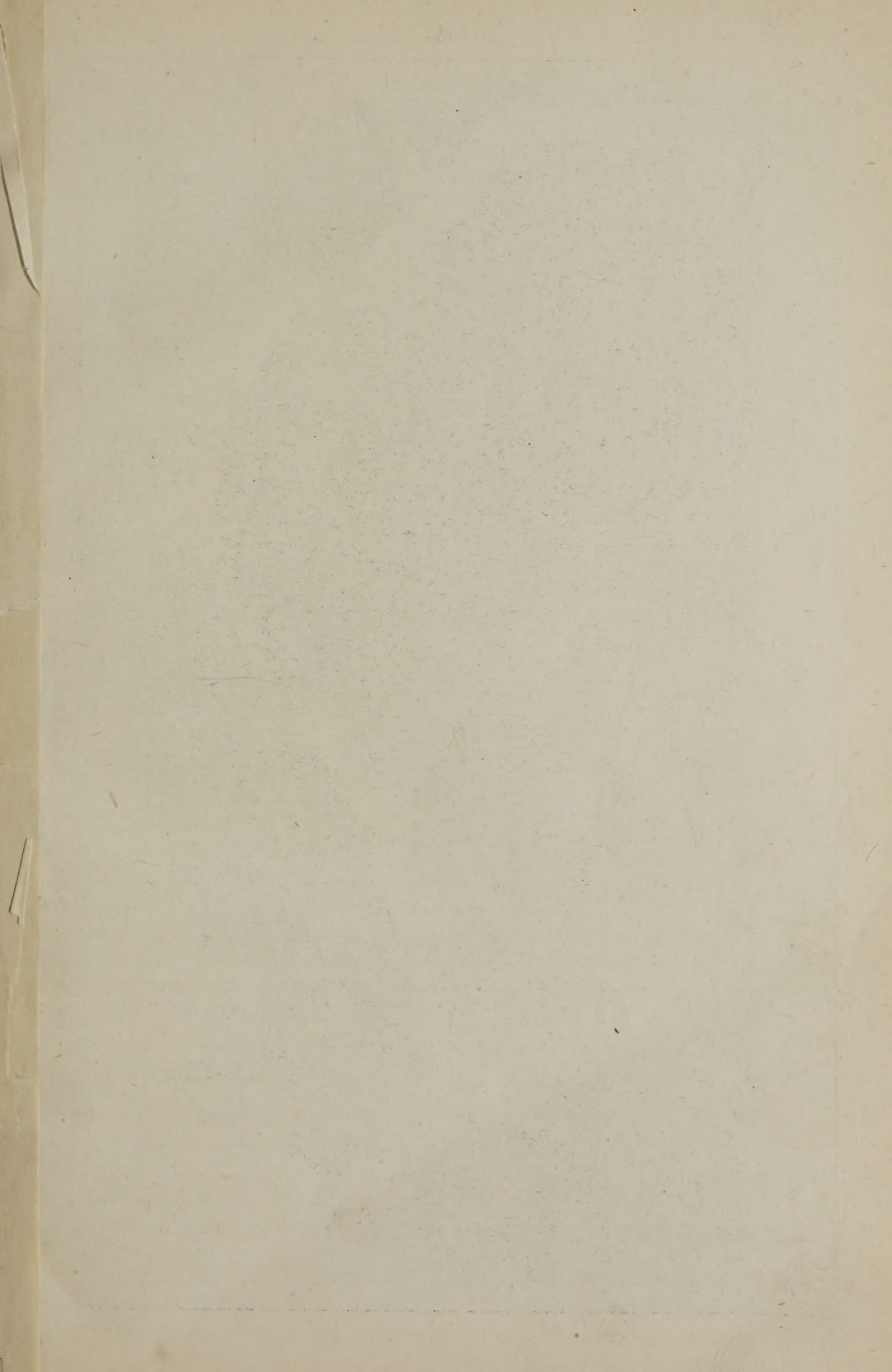



Where the Waters of the Famous Bull Run Battleground are to be empounded to Furnish Power to Washington and Baltimore.

OCOQUAN

DRAWN FOR
ELECTRICAL AGE
BY
E. MILLER JR. & BRO.
N.Y.

537.05

EA
V/30

REMOTE STORAGE

1490
34 244

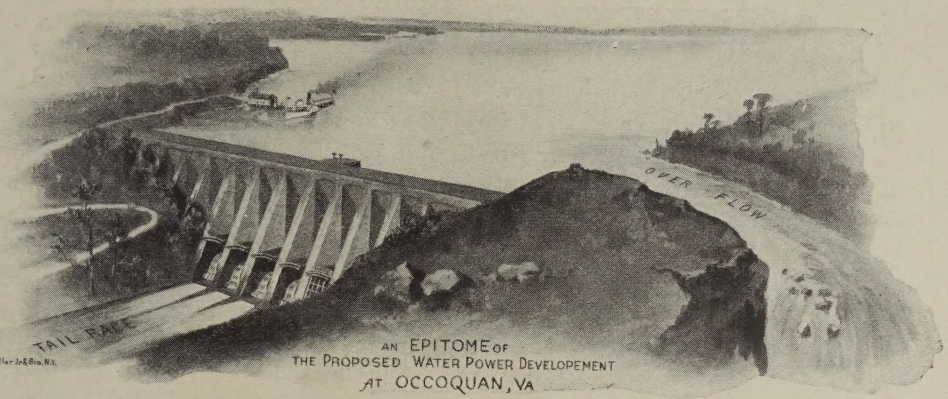

11221 0.6
1.04

Bull Run's Famous Battleground to Furnish Power to Washington and Baltimore

Occoquan

ON the historic ground where once rival armies met in bloody contest for the possession of the railroads at Manassas Junction, and almost on the site of the famous battle of Bull Run, peace is about to build one of her wonderful modern industrial monuments.

Where thousands of men contested for the key to Washington in the days of '61 the engineer is now about to take possession, and to turn the waters of Bull Run and the Occoquan River into power producers to operate street railways, lights, motors or other electrical adjuncts of the cities of Washington and Baltimore.

The emponding of the Occoquan waters is to be accomplished in a novel manner. Ordinarily, when streams are dammed, it is contemplated that at some time of the year, if not at all times, there

will be a surplus of water which must be allowed to escape without work. Generally this surplus is allowed to flow over the dam, and flood gates are often provided there to relieve the pressure and give freer vent when the floods become severe. Every hydraulic engineer would, of course, like to be able to empond all of the water that comes down the bed of his stream if that were practically possible. Then he would be able to get the maximum of power from his works and distribute its use as required over the whole year.

Only where ideal conditions exist could this be done. Such ideal conditions exist at Occoquan. The Occoquan River drains an area of 570 square miles. The stream itself runs through a valley in which, with works of small extent, a lake can be formed 25 miles in length,

one-half mile wide and of considerable depth. This lake would not trespass upon valuable lands, and its capacity would be great enough to take care of all the eccentricities of the flow of the streams which make up the Occoquan River.

Near the mouth of the river, and within a mile or two of where a railroad from Washington already crosses the stream, is an ideal place for a dam. It is a narrow gorge, rock bound on the bottom, and with hills of solid rock on either side. Building sand is found plentifully in the neighborhood, and the rock boundaries of the gully furnish inexhaustible supplies of admirable building stone.

Here is to be built a dam that will have but one side to it, so to speak. Since the purpose is to empond all the waters that fall on the 570 square miles of the watershed, the dam will be unique in its design. It will be of what is styled a "cellular" construction, and will closely resemble a piece of honeycomb sliced downward through a set of its cunningly contrived cells.

The dam will consist of a series of broad-based pillars, standing with their narrow edges in line with the bed of the stream. On the up-stream face of these pillars or buttresses will be built the wall of the dam in the form of a series of arches reaching from pillar to pillar. Thus, between each of the pillars will be formed a deep cell, with its open side looking down the stream. Since no water is ever to go over the top of the dam these deep cells are to be utilized for the placing of the turbines, generators and all the other power apparatus, thus combining the dam and power house is one.

An overflow or by-pass will be provided to let off any surplus water in case the flow should at any time exceed that which the engineers have considered—such as a cloudburst.

The dam as designed would be faced on the upstream side with steel boiler plate to make sure of keeping it free from seepage.

Occoquan lies only 24 miles from Washington in a southwest direction. The Southern Railroad runs within two miles of the site for the dam and power house, and a spur can easily be run up to the dam for the taking in of supplies, materials and machines.

The output of the power house would be transmitted to Washington or its vicinity under a pressure of 25,000 volts.

The following extracts from the engineer's report upon the project are interesting:

"The location of the proposed power station is to be just above the village of Occoquan, on the Occoquan River, being practically at the point where the Occoquan River meets tidewater in Belmont Bay, an arm of the Potomac River, about 20 miles below Washington, D. C. At this point there is a natural fall of some 40 feet in a distance of less than a mile. This fall is now partially used by a grist mill at Occoquan, to which water is carried from above the falls, partly in an open canal and partly in a wooden flume. This fall is only a small portion of the total fall obtainable by the construction of a dam built across the valley of the river at the point mentioned, where the high banks upon either side close in on the river, giving the shortest possible length.

"The topography of Fairfax and Prince William Counties, from the banks of the Potomac back to the foothills of the Blue Ridge Mountains, was originally a level plateau of glacial deposit overlying a very irregular rock formation. This plateau has been cut into by the rains and the streams coming down from the mountains, the deepest cuts naturally following the crevices in the original bed rock. The result has been the

formation of Cedar, Broad, and Bull Runs uniting to form the Occoquan River. The water shed drained by the Occoquan River is easily followed on the maps of the Geological Survey, and has an extent of 570 square miles. The basin included within the encircling divide finds its only outlet in a narrow rift through which the Occoquan River flows.

“By throwing a dam across this narrow rift a pond is formed whose area depends only upon the height to which the dam is built, the limitation being the elevation of the original plateau 250 feet above mean tide level. Practical considerations, however, limit the height to which the dam may be built, and these limitations afford quite a sufficient pond to store the entire rainfall of the area.

“The watershed has been carefully examined, and the geological character of the divide encircling the drainage area tributary to the Occoquan River is found to be of a nature insuring against the loss of any of the emponded water at other points than the natural outlet across which the dam is to be built.

“The actual flow in the Occoquan River is a matter of indifference, inas-

much as it is proposed to empond the rainfall so that it may be drawn upon at a definite continuous rate. The nature of the watershed is such that the rain as it falls finds its way almost immediately to the Potomac. In times of drought the stream becomes almost dry.

“The available flow, therefore, as ordinarily understood in water power discussions, is a matter entirely of rainfall, and the run-off that may result after considering the effect of the artificial conditions resulting through the construction of the dam.

Specifications

“The dam will be of Portland cement boulder concrete of the cellular emponding type.

“The foundation for the dam shall be prepared by excavating rotten and loose rock to give a firm, clean foundation to a form shown on the drawings.

“The up-river shear face of the dam to be surfaced with 3-16 inch sheet steel to give a waterproof result.

“The feeders will be of open hearth steel 5-8 inch thick, and of a size and construction shown on the plans.

“The power house will be designed to

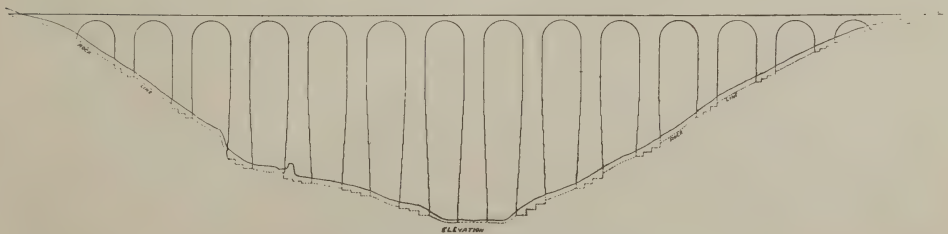
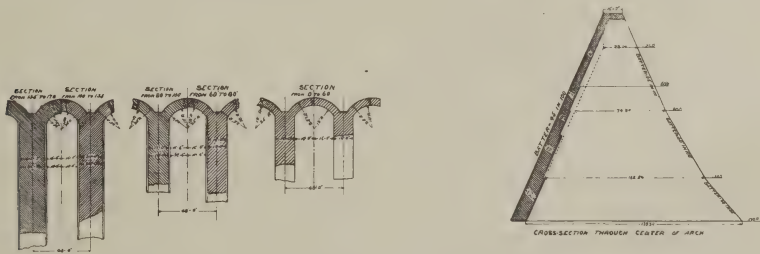

Details of Proposed Occoquan Dam.

accommodate itself to the cellular form of the dam, and to accommodate four units and two exciters, as hereinafter specified. There will also be furnished a proper heating and ventilating plant, such 20-ton hand power cranes as may be required, and an air compressor with fixtures for cleaning the electrical equipment.

"The hydraulic equipment will be composed of four special wheels for generators, and two special wheels for exciters, each wheel fitted with proper momentum wheel, governor and draft tube.

"The electrical equipment will be composed of four generators capable of developing 1,500 kilowatts each at 2,200 volts; two exciters of 120 kilowatts each, and will include complete station equipment, switchboard, wiring, governors, lightning arresters, and all other things necessary to a modern plant. An efficiency of 95 per cent. will be guaranteed.

"The lines will be composed of six No. 00 bare copper wires, carried on suitable poles, properly insulated and protected.

"The initial current to be stepped up to 25,000 volts at the power station, and delivered at point of use at 2,350 volts, there to be stepped down to voltage required by the consumers.

"The power present, as assumed from the studies by the writer; and as supported by the expert opinion of Mr. Hering, using the minimum continuous draught from the pond as 400 feet per second, and arranging the dam to overflow at an elevation of 155 feet above mean tide, with an average available head of 150 feet, is given in the following table:

Continuous minimum draught.	.400	second-ft.
Head	150	feet
Efficiency of turbines.....	75	per cent.
Efficiency of generators.....	95	"
Efficiency of step-up transformers	97	"
Efficiency of lines.....	93	"
Efficiency of step-down transformers	96	"

Theoretical 24-hour power...	6,800	H. P.
At turbine shaft.....	5,100	"
At station switchboard.....	4,850	"
At secondary switchboard....	4,000	"
Or 35,040,000 horse-power hours	per year.	

"In this case the extensive storage permits the water to be drawn only when wanted for power purposes. Figuring a combined electric traction and light consumer as a 12-hour power, as are all manufacturing concerns, the power available for 12 hours' sale is just double, or 8,000 horse power.

Recommendation

"It is therefore recommended that the power be developed as follows:

"The dam to be built at tide water as indicated on the map, and to an elevation of 160 feet, with the natural overfall arranged to give a high pond level at 155 feet above mean tide.

"The flume to be of metal and arranged to draw the water 30 feet below the over-fall level, thus permitting the pond to be drawn down to that level or to elevation 120 feet above mean tide. The curves previously discussed show this to be an ample range.

"The flume or feeder will conduct the water direct to the turbines.

"The power house to be located as shown on the plans.

"The units should be of the following sizes: turbines, 2,650 horse power; generators, 1,500 kilowatts. Four units to be installed at once. The exciters—using a factor of 2 per cent.—are to be two in number, each capable of exciting the entire plant, and will be 120 kilowatts capacity each, to be driven by a suitable single wheel.

"The plant will then be: 4 units, 1,500 kilowatts each; 2 exciters, 120 kilowatts each, with a maximum capacity of 8,000 horse power; at 25 per cent. overload, 10,000 horse power."



Electric Locomotive Hauling Sugar Cane in Hawaii.

Electric Power as a Factor in Social and Economic Progress

By GEORGE H. GIBSON

THE modern industrial age began with the use of steam in manufacturing and transportation. The steam engine accomplished a great revolution by substituting for the puny power of man the tireless energy bound up in fuels. But in order to utilize the steam engine it was necessary to transmit its power to the machine or vehicle or other device by which the work was to be done. At first the only method used was mechanical transmission by belts, shafts, pulleys, etc. Later other methods of limited application were used, such as compressed air and water under pressure, but the modern agent par excellence for power transmission and distribution is electricity. Its novel, valuable and peculiar characteristic is that by its means energy may be conveyed anywhere and under any conditions over slender, motionless conductors, con-

trolled with the greatest nicety and applied in any form. Electricity has furnished, also, the most valuable and convenient means of lighting, and electrochemistry has opened up a new branch of industries, the importance of which is only beginning to be felt. A very marked effect of the advance of electrical engineering is the stimulation of allied sciences and industries.

Manufacturing

Although the builder of a modern manufacturing establishment has available for power distribution steam, compressed air, water under pressure, the rope drive, and belts and shafting, there are many things for him to consider besides the mere transmitting of power from the engine shaft to the tool. He must bear in mind, first of all, the profitable operation of the shop. A system of

power transmission which, with the same equipment and working force, will enable 10 per cent. more work to be turned out than is possible by some other system of transmission, is many times more profitable, although it may cost more to install. Again, a system of transmission which will permit the erection of cheaper buildings, their easy and convenient extension with growth of business, or that will allow of an arrangement of tools advantageous to increased output by permitting work to be passed without confusion or delay from one operation to another, is worthy of the most careful consideration, even in the face of old and tried methods. Transmission by shafting and belting has long been in possession of the field, but electricity has shown such decided advantages in the many instances where it has been adopted that the manufacturer is compelled by self-interest to consider its merits.

As compared with transmission by shafting and belting electric driving has greater flexibility and admits of the location of tools with regard to the greatest economy of production. Additions to the works may be made at any time and in any direction without disturbing existing equipment. Full advantage may be taken of the convenience of overhead traveling cranes and portable tools—these "portable tools" sometimes weigh as much as 20 tons—and the lighting of the shop is unobstructed by belts and shafts; the building is not subjected to the continuous vibrations caused by heavy shafting and pulleys; the operative is not hampered in his work by inconvenient shafts and belts, and the shop is easily kept clean and orderly, which conduces to better and faster work.

In another aspect the influence of electrical power in factories is most happy from a human point of view. The

use of electric cranes, hoists, etc., liberates the workman from the severe and more common sorts of labor, and requires of him a higher grade of intelligence and efficiency. Perhaps this is in no place more evident than in iron and steel works. By the use of electrically driven charging machines and other appliances the workman, who formerly sweltered over the liquid steel, now sits in a comparatively cool and safe place and controls the movements of hot masses of metal by the mere throwing of a lever.

I have in mind a recent accident in a large blast furnace plant near Pittsburg in which about a dozen men were fatally injured. In the operation of a blast furnace it is necessary to periodically charge fuel and ore into a huge, bell-shaped door at the top of the furnace. Meanwhile more or less unconsumed combustible gases escape, which usually burn upon reaching the air; but in the present case an explosion resulted from the mixture of these gases with air, and some of the men who were dumping the coal and ore into the furnace were mortally burned. In most modern plants, however, no one is obliged to go near the mouth of the furnace while it is being charged, the whole operation being carried on by electrically operated skips and hoists.

Electricity appeals to the furnace owner in still other ways. The electrically driven skip equipment saves the services of top fillers at the furnace, and, at the same time, is more economical than the steam engines which have been used in this work. The modern electrical equipments are also much larger in capacity than the old style of hoists, thus making it possible to hoist material very rapidly at times when the furnace is running badly, and when it is important to fill it quickly. These changes, of course, all conduce to cheaper output,

which in the end results in a benefit to society at large. If the reader should have occasion to visit modern industrial establishments he will see many plants equipped for electrical power distribution, and I would draw his attention to their greater cleanliness and orderliness and better light as compared with shops in which other methods of transmission are used.

Transportation

Many and striking are the social changes brought about by the prodigious growth of electric traction. Electric

population of a city; or, in other words, increases with the density of population. This is quite the opposite of what one might expect. Since 1880 the population of the territory included in Greater New York has not quite doubled, but in the same time the number of rides has increased four-fold, and the number of rides per capita now amounts to 317 per year, the highest of any city in the world. The completion of the Rapid Transit subway and the Pennsylvania tunnel system will open up large areas in the Bronx district, New Jersey and Long

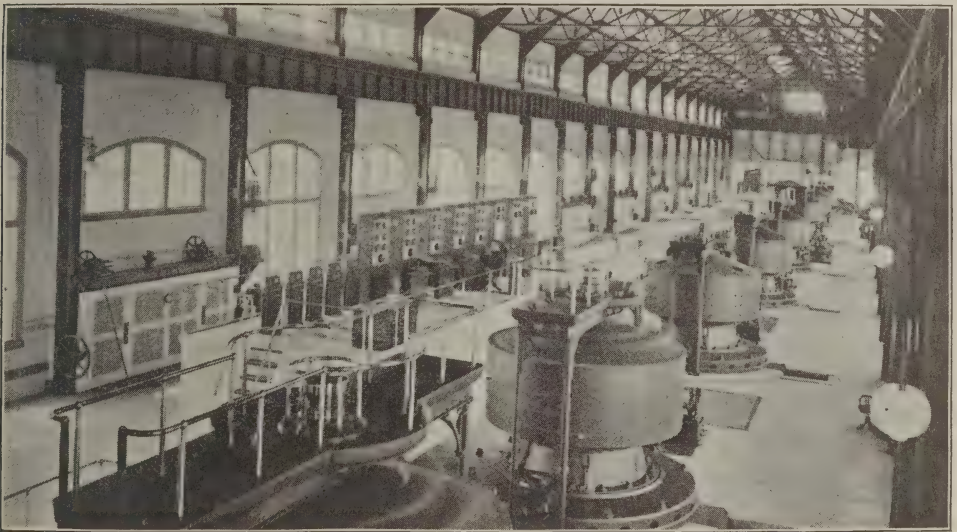

Five-thousand Horse Power Generators in Niagara Falls Power Company's Power House.

railways are among the most important factors in redistributing populations and building up suburban districts, and the development of most modern cities would be greatly hampered were the conveniences afforded by electric street cars lacking. A brief consideration will convince one that the further development of New York City, for instance, would be absolutely choked but for the numerous additions that are being made to its traction system. It is an interesting fact that the number of riders per capita increases much faster than the

Island to serve as homes for working people and to alleviate the great congestion of population on the East Side. Residents of New York were recently forcibly reminded of another important advantage of electric traction. The elevated railway still uses steam locomotives on some of its lines, and the anthracite strike necessitated a partial use of soft coal. Electricity had, however, already been installed on the Second avenue line, and the difference between the appearance of that street and others was quite obvious.

Electric traction is bringing about great, although not such apparent, changes by the development of interurban and cross-country lines. These roads not only provide easy and convenient means of traveling to the residents of many small towns and villages, but also go far to make more bearable the lives of the farming people. A notable example is furnished by the Union Traction Company, of Indiana, operating a system of electric railways including 153 miles of track and serving 300,000 people. This road connects the cities of Anderson, Indianapolis, Marion, Muncie and a number of small villages, and a project is on foot to greatly extend its territory, taking in Chicago and other large cities. Another large territory, comprising northern Ohio and Indiana, is rapidly becoming covered by a network of electric lines, the like of which is to be found nowhere else in the world. Some of these roads operate cars at speeds often reaching 50 miles per hour, and many carry mail, freight and express in addition to passengers. An Ohio road is even about to introduce sleeping cars.

In all places where electric roads have been built parallel to steam lines, a new demand for transportation has arisen, often very many times exceeding that before existing. This is to be ascribed to the convenience and frequency of the electric service even more than to reduced fares. Again, the frequency of the service is due to that peculiarity of the electric system of traction which permits small units to be profitably operated. The electric roads are creating a new field for themselves which was not open to the steam roads.

Indeed it may fairly be said that the electric railway is to perform a service for mankind as notable, and perhaps ultimately as great as that rendered by its

steam-operated precursor. Already it handles the bulk of suburban and short-distance interurban passenger traffic; it carries freight, mail, expressage, and baggage; it operates at speeds reaching 60 miles per hour; its cars run by time schedules and are dispatched by telephone; its roadbed is often as expensive and as heavy of construction as that of the best steam lines; and, what is more interesting to the investor, it pays large dividends. At the present time \$1,600,000,000 is nominally invested in electric roads in the United States, and upon this sum \$7,000,000 is paid yearly in dividends; 300,000 employees receive yearly in wages \$250,000,000, and there are 20,000 miles of track on which 60,000 cars are run. In 1899, ten miles of electric road were built for every mile of steam road constructed.

Mining

Although the first commercial application of the steam engine was to pumping and hoisting in the coal mines of England, steam generated power was never until lately very widely applied to lightening the arduous labor of the miner. The conditions under which mining operations are carried on make it necessary that the power used be generated outside of the mine. This implies some means of transmission. In early practice this was accomplished almost entirely by mechanical devices; ropes were used for hoisting and hauling, and the early Cornish pumping engines were provided with long piston rods extending from the steam cylinder at the head of the shaft to a pump cylinder far below.

At various times it has been attempted to use steam for power transmission, but steam lines of any considerable length are subject to a large amount of condensation, which gives rise to serious

trouble in the pumping and other machinery operated. Furthermore, the exhaust from the apparatus is disagreeable, and if of any considerable volume soon renders a mine uninhabitable. Even though the exhaust may be taken care of by condensation apparatus, the heat and leakage from steam pipes may raise the temperature of the mine to an unbearable degree. There is, also, the objection that steam piping is difficult to lay, and the general system lacks flexibility, durability and efficiency. Compressed air has been quite extensively used as a substitute. It is adapted for the same class of apparatus and escapes some of the objections that may be urged against steam. It may be carried to any distance without condensation, and the exhaust improves the conditions of the mine. However, compressed air has against it all the other objections placed against steam, and the added disadvantage of requiring expensive apparatus in the shape of compressors and re-heaters.

The most recent agent brought to the aid of the miner is electricity. As a means of power transmission it is unique in possessing all the advantages and possibilities of other methods and escaping their disadvantages. It is adapted to all classes of work, including hoisting, hauling, drilling and excavating in general, ventilating and pumping, as well as the additional use of lighting, which is possible with none of the other methods. Its flexibility is at once apparent. Electric wires may be run anywhere and under any conditions to be found in min-

ing work. They are easily and quickly laid, occupy small space, and may in a moment be tapped at any place at which it is desired to operate machinery.

In coal mining probably the most general and profitable application of electric power, besides pumping and hauling, is to the coal cutting machine. The ordinary method of under-cutting by means of the pick in the hands of the miner is most difficult, laborious and costly, as well as wasteful of coal. In under-cutting the miner lies on his side, often in a pool of chilly water, and picks away the coal at the bottom of the vein to a depth of four or five feet back from

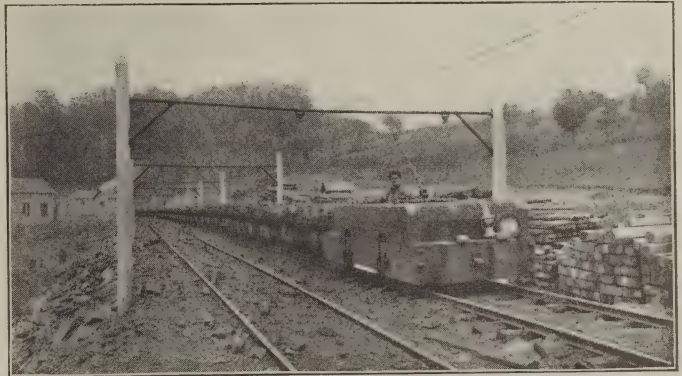

Electric Locomotive Bringing Coal Out of a Mine.

the face. The overhanging coal is subsequently brought down by blasting. The use of coal-cutting machines has resulted in a reduction of cost and waste, has increased the output of mines and has made possible the working of thinner veins. The coal mined in the United States in 1900 measured 270,000,000 tons, valued at over \$300,000,000, four-fifths of the coal being bituminous. About 53,000,000 tons of this bituminous coal were under-cut or mined by machinery and, since it is estimated that the saving in cost was 10 cents per ton, the total saving amounts to \$5,300,000.

Connected with metal mining is refin-

ing and reduction work, and in such work electricity has found a wide application, both for operating machinery and for lighting and electrolytic purposes. The Cripple Creek country is probably the most up-to-date of any mining district in the world. It has been said that there "a miner can go to his work in an electric car, descend the mine in an electric hoist, keep his mine dry with an electric pump, do his work by an electric light, run drills operated by electric-motor-driven air compressors (in some cases now being replaced by direct electric drills), and fire his shots by electricity from a switchboard far removed from the point of explosion." In addition, the refining plants at Cripple Creek are largely operated by electricity.

From the numerous examples of the use of electricity in both coal and metal mining, which have been cited above, it will be seen that while only a beginning, comparatively, has been made, the introduction of electric machinery brings about considerable savings and renders the life of the miner less arduous. Indeed, the extent to which electricity is adopted corresponds very closely to the extent to which mine owners and managers become familiar with this new means at their disposal. A close analogy is found in the case of the introduction of electric power distribution in factories, which progressed very slowly until a sufficient number had been equipped to make the advantages of electric power everywhere manifest.

Long Distance Power Transmission

So far I have spoken of electricity only as an agent in the distribution of power for the performance of various mechanical operations. The use of electricity for the transmission of power over long distances in the utilization of natural forces, otherwise unavailable, has

proved a most potent factor for the benefit of mankind, and has added resources to the wealth of many localities. When power is needed for manufacturing, mining or transportation, the question often arises whether it will be more economical to generate the power at the place where it will be used or to transmit it from some cheap but distant source of energy. That it is often cheaper to utilize the energy of some waterfall rather than to put in a steam power plant is shown by the many transmission plants which have been installed during the last few years.

Without going into a technical explanation of the matter, I may state that the range of power transmission with a given weight of conductors varies directly as the voltage employed. In the last few years apparatus has been perfected which admits the use of as high as 50,000 or 60,000 volts, with a great degree of reliability. In the words of a prominent engineer: "Apparatus as now constructed permits the use of 30,000 volts with practically no more risk of breakdown than was involved in the use of 3,000 volts in 1890. This means that in ten years the increase in practicable potential has multiplied the range of transmission by ten and the area of territory within the range of cheap water power by 100." The pressure of 50,000 volts gives a commercial range of transmission of between 100 and 200 miles.

The development of water powers by electric transmission is already proving an important factor in the building up of cities and manufacturing communities. An example is found at Niagara, where a large class of industries, in which the chief expense is for power, is rapidly growing up. The apparatus at Niagara, as originally installed, provided 50,000 horse power. This has recently been doubled to 100,000 horse power, which

is again to be duplicated by the erection of a large plant on the Canadian side. Immense power developments are also in progress on the St. Lawrence river, at Messena, N. Y.; on the Sault Ste. Marie River at Sault Ste. Marie, Mich.; on the Missouri River at Canyon Ferry, Mont.; at Snoqualmie Falls and the White River in the State of Washington, and at other places. The Missouri River plant is noteworthy as being the first in which 50,000 volts has been used commercially. The total capacity of the plant is 12,000 horse power, a large part of the power being transmitted 70 miles to Butte, Mont., where it is used in copper and gold mines and in smelters. A unique and very interesting plant is that of the San Ildefonso Company, consisting of five generating stations in the mountains, 8 to 20 miles from the City of Mexico. The five stations, which contain 19 water wheels connected to alternating current generators, are scattered over a considerable area of country, two of them being on one small mountain stream and three on another. Nevertheless, the 19 alternators are operated in parallel. The cost of coal in the City of Mexico is \$22 per ton and upwards.

It may not be amiss to note that these remarkable engineering feats rest on the discovery, made in 1831 by Michael Faraday, of the induction of electric cur-

rents. The alternating-current transformer, used for the conversion of low voltage currents to high voltage currents, and vice versa, consists essentially of two coils of wire wound on an iron core, and is the most simple application of Faraday's discovery. This piece of apparatus has grown from a simple scientific toy, or laboratory device, to one of the most important agents in the mod-

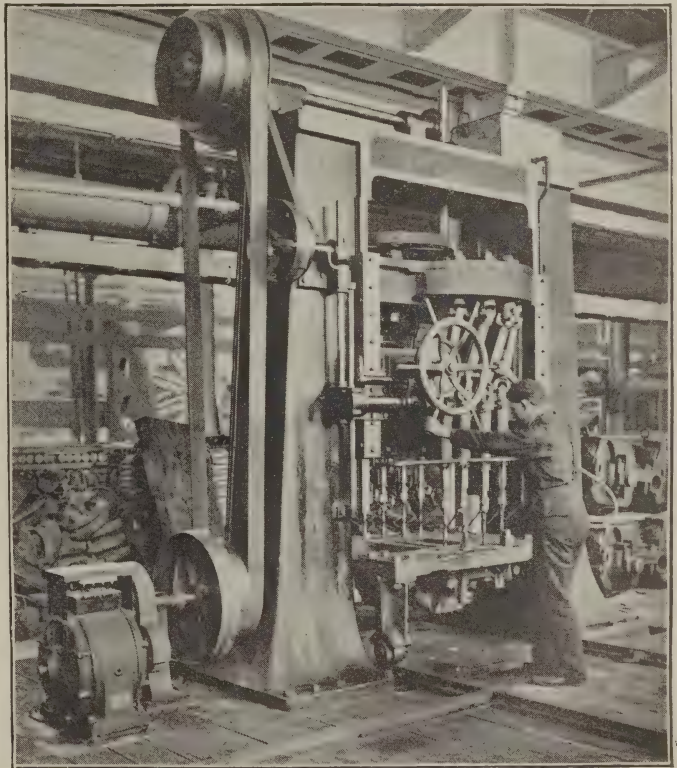

Electric Driving Applied to a Large Drill Press.

ern industrial world. The largest transformers ever built, having a capacity of about 3,740 horse power, were recently constructed for a large transmission plant on the Richelieu River, near Montreal, Quebec.

Electro-Chemistry

I remarked in the introduction to this paper that the science of electro-chemistry, the origin of which is also due to

Faraday, is only at the beginning of its development. However, the work that has been accomplished up to date is by no means inconsiderable. To electrochemistry we owe the fact that aluminum, once a curiosity in the chemist's cabinet, is now a commercial rival of copper as an electrical conductor. Nearly all the copper now produced is itself electrolytically refined; calcium carbide, from which acetylene is generated, is formed under the electric arc; ordinary bleaching powder is manufactured from common salt by an electrolytic process; carborundum, a new abrasive more effective than emery, is made in the electric furnace, which aspires to the production of graphite and even diamonds. In one or two European cities electrically generated ozone is used for the purification of the city water supply, and a company has even been formed to perfect a process of burning by means of electric discharges the nitrogen of the air for the commercial production of nitrates, a process which might go far to postpone that impending food famine so vigorously predicted by Sir William Crookes.

Electric Lighting

Although electric lighting for many years consumed nearly all the electrical energy generated and still uses more than one-half, and represents in the United States an investment of about \$669,000,000, I shall not expatiate on the benefits it has conferred upon humanity, since they are everywhere obvious. I shall, however, draw attention to several new types of electric lamps which promise great improvements in electric lighting and should widely extend its field of usefulness. I refer to the Nernst lamp, which is a new form of incandescent lamp; the Bremer lamp, a new arc light, and the Cooper-Hewitt

mercury vapor lamp, of which there is no commercial prototype.

The Nernst lamp, which was practically developed and is manufactured in America, takes its name from its distinguished inventor, Dr. Walter Nernst, of Goettingen, Germany. The principle of this lamp may be explained in a few words: The higher the temperature that can be withstood by an electrical conductor, as an incandescent lamp filament, the greater the proportionate amount of light given off for a given consumption of electrical energy. Dr. Nernst discovered that porcelain-like substances, although non-conductors when cold, become excellent conductors when heated, and may be raised to temperatures which far exceed any that carbon can stand. The Nernst lamp has, therefore, instead of the carbon filament of the ordinary incandescent lamp, a porcelain glower. Owing to the unique properties of the latter, its consumption of energy is less than half of that of the incandescent lamp for equal illumination. The quality of the light is also very much superior, closely approximating the yellowish white of afternoon daylight.

The Bremer lamp is a variety of arc lamp, in which, however, both carbons point downwards, resulting in the best distribution of light. One of the carbons contains a composition of rare earths, giving a soft yellowish light and a practical efficiency about three times that of the ordinary arc lamp.

Mr. Peter Cooper Hewitt's lamp makes use of the incandescence of a vapor or gas. It is still in process of development, but promises an efficiency about nine times that of the ordinary incandescent lamp.

The development of new inventions like the foregoing, which is often very costly, is carried on by many large con-

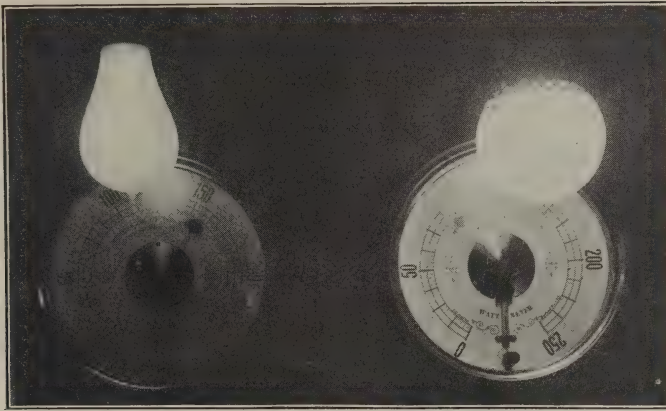

Comparative Lighting Effect of an Ordinary Incandescent Bulb and Nernst Lamp.

cerns in this country as an adjunct to regular manufacturing, and constitutes perhaps one of the greatest human blessings due to the extensive commercial enterprises of the present day.

Electrical Development as a Measure of Civilization

If mechanical and engineering developments are a measure of the civilization of a country, it may be a source of gratification to us to know that we live in by far the most electrical country on the face of the earth. The total electrical power in kilowatts per 1,000,000 people in the whole world, outside of the United States, is 640; in Great Britain, the highest outside of the United States, 7,000; while in the United States it is 26,320. The total capital invested in electrical undertakings in the world outside of the United States is 45 cents per capita; in Great Britain, the highest outside of the United States, it is \$4.25, and in the United States \$38.18. The miles of electrically-operated railways are, in the whole world, outside of the United States, 4.64 per million people; in Germany, the next highest of foreign countries, 41.8 miles, and in the United States 276.2 miles. Even more striking is the fact that the new plant of the Manhattan Elevated Railway Co. of New York City

will have a total power, available for traction, of 40,000 kilowatts, equal to the total electric power available for traction purposes in France. One of the 5,000-kilowatt generators would suffice for the electric railways of Switzerland. Further, as has been pointed out, if we take New York City as a unit, the total power now available, or shortly to be available, will approximate that at present found in the Empire of Germany or in Great Britain, and would operate all the electric railways in Europe. The five mammoth power houses on Manhattan Island have a total normal rating of some 322,500 horse power and a maximum rating of 478,000 horse power. This is enough power to lift the whole population at the rate of 80 feet per minute, or much faster than an athletic man can for any length of time run up stairs. In other words, the work of these five central power stations alone, all of which excepting one are to be used for transportation, is more than could be done by all the people on the island working continuously at a huge treadmill. In the United States we have 69 per cent. of all the electricity available in the world, 76 per cent. of all that portion available for traction, 76 1-2 per cent. of all the electric railway mileage and 83 1-2 per cent. of all the trolley cars.

A Ballad of Electric Light

(From the Bulletin of the New York Edison Company.)

How very strange it must have seemed
 In olden times of long ago,
 When of Electric Light none dreamed;
 When witching belle and dapper beau
 Made merry 'neath the candles' glow,
 Thinking the tapers wondrous bright.
 Little of Progress did they know,
 For Progress only means more light.

In later years the lamplight gleamed,—
 The course of Progress is but slow,—
 A noble sight 'twas then esteemed
 To see rich lamps set all a-row.
 Sometimes too high, sometimes too
 low,
 They never burned exactly right;
 They were considered triumphs
 though,
 For Progress only means more light.

Then later still, the gaslight streamed;
 As years pass on men wiser grow,—
 A great invention this was deemed,
 Its brilliant rays so far 'twould throw,
 A radiant light it would bestow;
 'Twould turn to day the darkest night;
 But 'tis no longer "comme il faut,"
 For Progress only means more light.

L'ENVOI.

Electric Force, to thee we owe
 Unmeasured Power, unbounded
 might;
 And thy illuminations show
 That Progress only means more light!
 —Carolyn Wells.

The New York State Canal Question

By FRANCIS L. PRUYN, A. M. A. S. C. E.

THE canal question in New York State has been so constantly a subject for discussion during the past ten years that the majority of people have become confused by the numerous contradictory reports, and, as a result, a most helpless state of indecision has been produced in the minds of all. To overcome the vagueness with which the subject seems clouded, let us propound and answer the three simple questions:

First. Are canals desirable?

Second. If so, what size and section is most suitable for the present case?

Third. How much will they cost?

In answering the first question, let us start with the general axiom that freight rates control the welfare of the world. Point out the country where freight rates are high, and there will be found industrial stagnation. Point out the country where rates are low, and there will be found commercial prosperity.

It is a matter of history that the old robber barons along the Rhine, by plundering the traffic floating past their doors, forced freight rates up to a point where the transportation business became unprofitable, and it stopped.

In some European countries to-day, where railroads are held as government or private monopolies, freight rates take undue tribute, and trade stagnates. Take, for example, the case of Great Britain. Forty years ago it possessed the cheapest internal transportation known to any country in the world, and in the aggregate rewards of industrial

energy it was apparently unapproachable. However, the principle of conserving vested rights has enabled the managers of its railroads to maintain freight rates without sensible diminution since that time, and has also enabled them to prevent competition from enlarged canals. What has been the result? At that time England stood easily first among the industrial nations, while to-day, because her manufacturers and consumers pay more per ton mile for transportation freight than any other great nation, England stands second or third in rank.

In our own country we have been more fortunate, and the last decade has been marked by steadily decreasing freight rates, which have been accompanied by constantly increasing commercial activity. The causes of this are not difficult to find. In the seventies and eighties railroad building was in the air. Boom railroads were projected and built with amazing prodigality and despatch. The country awoke to find itself possessed of not only more railroads than it could profitably use, but also more than it needed for some time to come. The old law about "survival of the fittest" began to work automatically, rate wars followed, and, in spite of temporary respites in the shape of pools, competition existed and rates continued to fall. Incidentally, of course, commerce benefited. The outcome of the matter was that a few master minds, foreseeing the chaos of such an order of

things, began to acquire control of the weaker lines by purchase or by syndicating stock interests, creating railroad systems which controlled whole sections where before were competing lines. To-day a few groups of men dictate the policy of some of the greatest systems of railroads on earth, and they are still acquiring competing lines.

The inevitable outcome of the railroad situation in the United States will be that the country will be divided up into sections, which, on account of natural geographical reasons, are non-competing. Each of these sections will be controlled by a single railroad system, and competition will cease. It may be the policy of the men who control these systems of railroads to continue to lower freight rates in the future. Still, this will depend simply on questions of business policy. They must look out primarily for their own interests and for those of their stockholders, and there is room for great differences of opinion as to what the traffic ought to bear and what rate of interest watered railroad stocks should pay. Even if the men in control were infallible, it is not pleasant to feel that they alone have the power to decide such momentous questions—questions that affect the lives and happiness of so many millions of people.

Let us not forget the object lesson furnished us by England, and repeat her error of allowing her railroads, because at that time they afforded the cheapest service in the world, to gain absolute control of transportation facilities, only to make her groan, years later, under the highest freight rates in Europe.

The Socialist is quick to tell every one that Government control of railroads will solve this whole intricate and perplexing problem. But will it? There are questions involved that he dreams not of—questions of the true functions of government and questions of constitution

that are rooted so deep down in our commonwealth that a tremendous upheaval would be required to tear them out. Questions of efficiency and cost and of management by political patronage are also involved. The Government railroads of Europe have higher freight rates than are prevalent in the United States to-day, and it is probable that, with our present system of distributing political favors, our own Government railroads would be even more expensive.

The psychologist asserts that there are two ways of producing an impression on the mind, namely, by direct assertion and by indirect suggestion. They are both, sometimes, equally effective. We might liken the first and more direct method to that of a Government control of railroads to secure and assure lower freight rates, and the second to its control of canals for the same purpose. A canal may be broadly defined as the cheapest form of communication between two points, and a State, in building a suitable one, creates an ideal condition in regard to freight rates which can always be held over the railroads as the goal toward which they should aspire.

We can, therefore, safely assume that canals are necessary to any State or Government in order to check the inevitable increase in freight rates that appear as soon as a railroad obliterates competition.

In answering the second question, as to the most suitable size and section for this canal, we must pause for a moment to consider a point which is not generally recognized, viz., that the true function of a canal is simply to reduce freight rates. When it ceases to do this it becomes a useless ribbon of semi-stagnant water. For want of a better name, we might call these two classes transit and transfer canals.

A canal is usually built to connect two centers of trade or two bodies of water which tap trade centers. If the traffic at one terminus can be carried to the other without intermediate terminal transfer charges, the canal offers the cheapest form of transportation. This is a transit canal.

There is a saying in railroading that it costs as much to move freight across a "yard" as it does across a continent, and it applies even better to a canal than it does to a railroad.

With each transfer charge on goods seeking to use the canal the economy in transportation is cut in two. A canal system where cargoes must break bulk between main shipping points is a transfer canal. Keeping these facts in mind, the cause of failure of many of our canals is apparent. Take, for example, the Erie Canal. It was a success so long as trade shipments lay between New York and Buffalo or intermediate points. Just as soon, however, as the centers of trade shifted and it became necessary to ship freight beyond Buffalo and beyond New York, transfers to larger vessels than canal boats were necessary. It became a transfer canal where it had been a transit canal, and fell into disuse.

The Erie Canal became a failure as soon as the terminal points extended beyond Buffalo, because its barges were unfit for lake navigation, and their cargoes had to be transferred to larger vessels. The project for a 1,000-ton barge canal now before the State does not promise to change this condition. The substitution of larger for smaller barges does not change the necessity for transferring their cargoes to and from vessels better suited for lake navigation. It simply substitutes a large experiment for a small one. If the present barge canal which we know by the name of the Erie had continued to be a success, what more natural than

that the State should expend many millions of dollars to increase its cross section to accommodate larger barges, thus adding to its usefulness. But when this small barge canal has proved an economic failure, on what logical grounds can the promoters of the 1,000-ton barge canal base their hopes for financial return to the State?

Only with a canal large enough to pass the lake vessels through to their points of destination without breaking bulk can the true functions of the canal again be established, thus renewing its great public utility. This, we believe, is the logical conclusion in answer to question No. 2.

Taking up the third question, that of cost, we will have to discuss in a general way the two projects in order to arrive at conclusive results.

The latest plan for a 1,000-ton barge canal, as advocated by the Governor of New York, proposes a route through the Hudson and Mohawk rivers and Oneida Lake, reaching Lake Ontario at Oswego; from thence by lake and the Welland Canal to Buffalo. The approximate cost of such a canal would be \$40,000,000. It would appear, therefore, that the Governor of New York, and probably the Legislature behind him, advocate the expenditure of \$40,000,000 on a 12-foot water way, of doubtful utility to the State, connecting Lake Ontario with the Hudson River. Therefore, it would seem reasonable to suppose that they would advocate a like expenditure on a larger water way, whose utility is almost unquestioned, provided somebody would advance the additional money required to meet the increased cost.

The enormous benefits that would be conferred on every person in the United States by a ship canal connecting the Great Lakes with the Atlantic Ocean can hardly be overestimated. Every

State on the Atlantic seaboard would receive its share in the cheapened price of every article produced or manufactured in this wonderfully productive lake region. Every foot of the canal and every harbor on the lakes would become a seaport, and every shipper would have his field of attack extended from its present dimensions to include the whole world. The surplus of this wonderful region which is now swelling our immense export trade could be laid down at the markets of the world without breaking bulk, and, therefore, at a price that would assure old business and stimulate new, establishing new markets, and so conferring untold benefits on every producer and manufacturer in the whole length and breadth of the United States.

The traffic on the Great Lakes is greater than that of any similar body of water in the world, and amounts to 40,000,000 tons of freight a year, so that, in importance, this deep water way would rank first among the world's greatest canals. If we compare the amount of probable traffic with that of the Suez or proposed Nicaragua or Panama canals the figures for these latter appear insignificant. The Suez Canal cost \$93,000,000, and has a yearly traffic of 8,500,000 tons. The proposed Nicaragua Canal would cost \$200,000,000, and, it is estimated, would have, in 1909, a yearly traffic of 7,000,000 tons. The proposed deep water way to the Great Lakes would cost \$200,000,000, and, if completed in 1908, would have, it is estimated, a yearly traffic of 36,000,000 tons.

Let us glance for a moment at the present traffic conditions on the Great Lakes, and endeavor to form an opinion from them as to the tonnage likely to use this canal. The traffic through the Sault Sainte Marie Canal amounted, in 1899, to 25,000,000 tons, and the tonnage through this canal has doubled in vol-

ume every six years for the last 24 years. Coming eastward to the Detroit River, the traffic in the same year was 40,000,000 tons. The reason for this enormous amount of freight taking on the lakes is because of the difference of rates on low-class freight on railroad and lake between Duluth, Chicago and Buffalo. It is difficult to believe that if, by reason of a ship canal to the Atlantic Coast, freight rates were considerably reduced a large proportion of the lake traffic would not pass through this canal, since it could be done without breaking bulk. It is also logical to suppose that a large amount of new business would be created.

The route recommended by the United States Government Commission for a 21-foot water way is practically the same as that advocated by Governor Odell for the 12-foot barge canal from New York to Oswego. Beyond this point the deep water way would leave Lake Ontario at Lewiston; from there, by eight locks, ascend to Lasalle, and from that point follow the Niagara River to Buffalo, a total length between terminal points of 477 miles. The proposed width of the canal is from 215 to 250 feet, with locks capable of taking in vessels 550 feet long, 50 feet wide and with 19 feet draft.

The estimated cost, including all necessary enlargements of lake channels, is \$200,000,000. Allowing one-eighth for interest during construction and with interest at 3 per cent.—which is high—the yearly charges would be \$6,750,000, plus maintenance, estimated at \$2,300,000, or a yearly total of \$9,050,000. The small toll of 25 cents a ton, on the estimated capacity of 36,000,000 tons, would offset this. It is estimated that a steamer capable of steaming $12\frac{1}{2}$ miles per hour on the open lakes can make eight miles per hour in the canal and canalized rivers; and, allowing for delays of 23 hours in passing through the 37 locks,

a steamer could make the trip from Chicago to New York in six days.

The average charge on the lakes for low-class freights from Chicago to Buffalo has been about 50 cents a ton, of which 33 cents only is due to the distance carried, and 17 cents is due to terminal charges. Since these terminal charges would remain the same, the only increase in cost for carrying freight to New York would be that due to the additional time of transit. This increase would be as 890 miles is to 1,742 miles, or the charge per ton for transportation proper would be 65 cents instead of 35 cents. Add to this the 17 cents due to terminal charges and the 25 cents of canal toll, and we get, as the total charge for carrying low-class freight from Chicago to New York, \$1.07 per ton, or 0.8 mills per ton mile. This charge is equivalent to 3.21 cents per bushel of wheat. Through the lakes and Erie Canal the charge in 1898 from Chicago to New York was 4.82 cents per bushel, or a saving in favor of the 21-foot ship canal of 33 per cent. over the cheapest and slowest route now available. The lowest average rail and lake route from Chicago to New York was in 1898, when the rate was 5.4 cents per bushel. This would show a saving of 41 per cent. in favor of the ship canal. The lowest average all-rail route is given in rate cards at 10 cents per bushel, although 6 cents per bushel has sometimes ruled from Chicago to the sea shore. As six days would be the time of transit from Chicago to New York by the 21-foot canal, it is probable that a large amount of high-class freight which is now being transported by rail at a rate of from \$6 to \$15 per ton would seek this cheaper route. For wheat, iron and other products going to points on the Atlantic Coast beyond New York not now reached by canal boat transfer charges at New York could be saved by ocean

steamers loading at the upper lake ports. The cost now due to time lost by both vessels while making freight transfers would also be saved, and the total saving to points beyond New York would amount to \$1.67 per ton.

In estimating the number of round trips which could be made by each vessel in a season the delay of loading and unloading at the terminals is the only quantity about which experts differ. Lake steamers running from Duluth to Buffalo average three days in port per round trip. Allowing four days per round trip for delays at terminals between Chicago and New York, we have 16 days as the average time of transit, and, with an open season of 245 days, a steamer would be able to make 15 round trips per season. The difference in cost between a strong, durable, ocean-going steamer and the less heavy, short-lived ones now in use on the lakes has been greatly exaggerated. The heavier class of vessels would, of course, be better adapted for the traffic, and when we compare the difference in cost of construction to the advantage of being able to use such a vessel 12 months in the year instead of the eight months of the lake season, the net income result is greatly in favor of the ocean-going craft. A fleet of ocean-going steamers that used the lakes and canal during the eight months' open season could be employed to advantage during the remaining four months of the year in our rapidly increasing coast and foreign trade. Such a fleet would go far toward solving the vexed question of our need of a merchant marine, both in peace and in war, while the building of these vessels, and the fact that we were carrying our exports in our own bottoms, would give an impetus and encouragement to our ocean-carrying trade that would be of inestimable value.

As before stated, the cost of such a canal would be approximately \$200,000,000, and, if New York State would place before Congress a request to have it built, offering to expend on her own account \$40,000,000 toward its construction, it does not seem improbable that

the measure would be passed with little real opposition. In place of a temporary makeshift for an obsolete canal system we would then have an up-to-date ship canal that would economically serve the purpose for which it was designed for 100 years to come.

Electric Traction on German Canals

(From the "Electrical Review," London.)

DURING the early part of this year tenders were invited for an electric installation for traction purposes on the Teltow Canal. This canal connects the Havel and Spree not far from Berlin. It is 23 miles long, and has one lock. The tonnage of the boats varies between 450 and 175 tons, and they will be loaded to about 67 to 70 per cent. of built on both banks of the canal, with the exception of a short distance, where special arrangements have to be made. There are 12 loading stations on the canal. Electric power is supplied in the form of three-phase current at 8,000 volts and 50 periods. The price has been estimated at about 1 pence per kilowatt hour.

Twenty firms sent in tenders, including Siemens & Halske and Ganz & Co. The proposed installation of the latter firm is, perhaps, the most interesting. It is claimed by Ganz & Co. that, although their locomotive is very light, it will have great hauling capacity, and the greater the tractive effort the greater will be the stability of the tractor. The locomotive has two pairs of wheels, which are inclined at an angle to one another, and run on a single rail, main-

taining its balance by means of another wheel running on the roadway. The greater part of the weight, however, is thrown on the axles of the inclined wheels. These obliquely-running wheels are so arranged that the greater the resistance offered by the boat the greater is their grip on the rail. This must necessarily increase the stability and the hauling capacity of the locomotive. In this respect the Ganz system somewhat resembles the system devised by Messrs. Thwaite and Cawley some years ago.

The locomotive is equipped with a three-phase motor having its axle parallel to the rail. The frequency of 50 periods entails double-reduction gearing; if a frequency of 15 or 25 periods were adopted, single reduction would have been sufficient. This would have increased the efficiency of the motor.

The efficiencies at full load are as follows: 0.90 for the motor, 0.94 for the gearing, 0.80 for the worm-gearing, making a total of 0.68 for the whole. The capacity of the locomotive is 37.5 horse power.

The current is supplied to a two-wire trolley line at a pressure of 500 volts, the rail serving as a return conductor. The current is taken off the trolley lines by

means of two wheels running along the wires, the locomotive drawing them along as it moves.

For a short distance the canal passes through a broad lake, which makes it impossible for locomotives to be used. Here electric tugs are requisitioned to tow the boats. They are driven by two three-phase motors, each of 67 horse power capacity. Current is supplied to them by means of overhead lines supported by transverse wires.

The difficulty of passing stationary boats is overcome by fixing a steel rope above the towing path at the loading stations; from this rope is suspended a runner which lifts the tow rope and allows it to be fixed to the mast of the boat.

For an annual traffic of 1,500,000 tons it will suffice to equip one bank of the canal. A locomotive can draw one boat of 600 tons, or perhaps two of 175 tons. The service would require 53 locomotives and six tugs, including reserve.

The price quoted by Messrs. Ganz & Co. for the above was 1,242,000 francs (£49,680). For a traffic of 4,500,000 tons yearly, requiring 115 locomotives and eight tugs, including reserve, the same firm quoted the additional sum of 1,193,000 francs (£47,720). The working expenses, calculated on the basis of 1,500,000 tons annual traffic, amount to .0050 franc per ton kilometer.

Below is given a comparative table, showing the first cost and the working costs, as given by some of the firms who submitted tenders for this project:

	First cost. Francs	Cost per ton-kilom Francs
Siemens & Halske...	2,750,000	0.0102
Feldmann & Zehme.	?	0.0082
Societe de Touage, Kiehl.....	3,200,000	0.0098
Ganz & Co.....	1,242,000	0.0050

The above figures are based on a traffic of 1,500,000 tons per annum and a price of 12 pfennig (1.4 pence) per kilowatt hour.

Combined Pistol and Dark Lantern

A device designed for the protection of householders suspecting the presence of burglars is a combination of revolver and dark lantern. In a short barrel chamber, immediately below the barrel of the revolver, is a small incandescent lamp, which is caused to light through

the pressing of the trigger. This device is intended to afford sufficient light for a steady aim without affording a mark for return fire. It ought to prove equally as serviceable in the hands of the up-to-date burglar as in those of the peaceful resident.

Self-Luminous Mixture

The new self-luminous mixture of a French chemist, claimed to require only very short exposure to light and to be unusually brilliant and lasting, consists of 20 parts of dehydrated sodium carbonate, 5 of sodium chloride, 1 of mag-

nesium sulphate, 500 of strontium carbonate and 150 of sulphur. The well-mixed materials are kept at a white heat for three hours in a muffle from which the air is carefully excluded.

America's First Steel Roadway

By FRANCIS F. COLEMAN

THE first section of the new steel roadways which are to be tested in New York City under the auspices of the Automobile Club of America has been laid on Murray street on the block which runs westward from Broadway, opposite City Hall Park, to Church street.

Another section is to be laid either in Seventh avenue or St. Nicholas avenue above 126th street, where there is much auto car traffic and light driving, and a third section will be laid on one of the popular roads further up town, probably in the Bronx, over which swarms of auto car owners go in making trips to the suburbs. Each locality has been chosen with the idea of subjecting the new style of road to different characters of tests.

Although the chief movers in the introduction of the steel roadway are persons who desire better roads for automobiles, it is realized by them that no form of road would be publicly adopted unless it proved to be durable and also popular with the users of other kinds of vehicles.

The block in Murray street on which the first section of steel roadway has been laid was chosen because it is much used by heavy trucks coming from the wharves and wholesale district to the west and south of the City Hall on their way to Broadway and the Brooklyn Bridge. The street has a considerable up grade toward Broadway, and it is believed that the easier traction offered by the steel roadway will make it much

sought by the truck drivers. It is believed that the sections to be laid uptown will be sought chiefly by auto car drivers, who will find the new roadway not only much pleasanter to ride over than the older forms of pavement, but that they will save much wear and tear on their automobiles.

For experimental purposes, one mile in length of steel road will be laid altogether. The steel for this was contributed by Charles M. Schwab, president of the United States Steel Corporation, who had the rails specially rolled for the purpose. General Roy Stone, of the Bureau of Road Inquiry of the Department of Agriculture, Washington, D. C., designed the roadway. The section in Murray street was laid under General Stone's personal direction. The cost of the work was met by the Automobile Club of America.

The steel roadway consists essentially of flat-faced channel bars of steel one foot wide, with tapered flanges three inches deep to stiffen them and give a hold on the sub-roadway. These rails are each 40 feet long and weigh about 1,060 pounds. At either side of the upper surface, above the edges of the flanges, are slight rounded flanges 3-8 inch high, meant to serve as a guide to vehicle wheels and to keep them on the rail. The rails as laid are spaced 4 feet 6 inches apart on the inside, giving an outside measurement of 6 feet 6 inches. At intervals of 13 feet steel rods, 3-4 inch in diameter, reach across from



Laying the New Steel Roadway in Murray Street, New York.
Constructed by General Roy Stone, under the Auspices of the Automobile Club of America.

rail to rail and pass through the flanges. Sections of gas pipe threaded on the rods keep the rails from moving toward one another and nuts on the ends of the rods keep the rails from spreading.

The roadbed was prepared as follows: After the Belgian block paving was taken up, trenches 18 inches deep and of like width were dug along the rail line. At the bottom of each trench was laid a course of paving stones. Upon the paving stones was dumped broken stone. The broken stone was rammed into place solidly in thin courses until it presented a rounded face a little higher

than the final level of the street, and about 6 or 8 inches wider than the rail. The rails were then placed flanges down on the stone, and settled solidly down upon and into the bed of stone, by ramming. The rails on either side of the track break joints. The ends are joined by fish plates each held by four bolts.

After the rails were in place, the granite block pavement was put back, leaving the upper surface of the rails flush with the rest of the street.

The Murray street section is 438 feet in length. Work was begun on it on November 17. A test made after the

road was finished, on December 17, showed that the steel roadway made a saving of about 40 per cent. over the granite pavement in the power required to draw a wagon up the grade. The roadway is single track and lies in the middle of the street. Trucks going up grade have the right of way over it.

Steel roadways of this character have been in use for years to save wear and labor on the planked roadways of bridges, but there is only one in the world except that in Murray street in use on a general highway. This is in Spain, near Valencia. It is a stretch two miles long, put down seven years ago at a cost of \$9,506. According to figures furnished by General Stone, an average of 3,200 vehicles pass over this road a day, and the cost of maintaining it has been but \$380 a year against \$5,470 a year which was expended on the roadway which it has replaced.

The movement for good roads in the United States which took on definite form but a few years ago, is becoming general. The widespread use of the bicycle gave it a great impetus, and now the rapid increase in the number of automobiles has brought into the movement many of the most influential and progressive men in the country.

The need of better roads is emphasized with every attempt of automobilists to tour the country. Cars that could run for months over city pavements without serious mishaps are put out of commission in a few hours even in making trips between the great cities of the East, while from other parts of the country come tales from venturesome automobilists which are marvels of hard luck. They tell of ploughing through miles of hub-deep mud or over jagged, rocky highways, that tear away tires and rack machines to pieces.

State aid for good roads has done wonders in bettering conditions in some

parts of the country. This is notable in New Jersey and Massachusetts. The Bureau of Road Inquiry at Washington is doing good pioneer work, sending its corps of road makers and its road-making machinery from one part of the country to another, teaching people how to make good roads. The railroads have heartily co-operated in this work by furnishing transportation for men and machines.

A new movement is now on foot to give Government aid for good roads. It is directly in line with the present State aid laws. Under the State aid laws the States give a portion of the cost of building improved roads. Usually this proportion is one-third. The county gives a third and the township the other third.

A bill is now before Congress, introduced by Representative Walter P. Brownlow, of Tennessee, to create a Bureau of Public Roads at Washington, and to appropriate \$20,000,000 to carry out its work. The bureau would make investigations and experiments as to the best methods of road making in the various parts of the country to be benefited, co-operate with local authorities everywhere in designing roads, and it would supervise the work to be done. As the bill now reads, one-half of the cost of the roads built under it would be paid out of the \$20,000,000 appropriation. The bill has been well received, but there appears to be some difference of opinion as to what proportion of the cost of the roads should be paid by the Government. The money would be spent in the different States in proportion to their population.

An interesting subject which is now being investigated is the value of asphaltum-based petroleum, such as the oils of Texas and California, for road making. It is asserted that this oil, when sprinkled over ordinary dirt or gravel roads in quantities sufficient to fill the

earth to a depth of three inches or so, makes an asphaltum covering which not only keeps down dust in dry weather, but makes the road water proof and prevents its breaking up in wet weather. Coal tar has been recommended for a like purpose. If these claims should prove well founded, this method of treating

roads would be of the highest value. In nearly every locality material is at hand which makes good dry-weather roads except for dust. If oil or tar would protect these from breaking up in wet weather, it would make good roads possible at so low a cost that the whole country would soon be gridironed with them.

Thawing Frozen Water Pipes by Electricity

THAWING out frozen water pipes with electricity has become a regular winter occupation in Sault Sainte Marie, Mich. Pipes as large as four inches in diameter which were more or less frozen up for 200 feet or more have been thawed out successfully, while the ordinary service pipes for household and store supply are treated in this way with the greatest of ease.

The system used is one which might well be adopted in every cold part of the country where current is available from electric lighting or trolley wires. It is a much simpler method than the customary one, and withal cheaper, quicker and more satisfactory. In the case of the four-inch pipe, frozen for 200 feet of its length, the work of thawing only took half an hour, while with the smaller pipes relief is almost instantaneous.

All that needs to be done is to connect the current-carrying wires to the frozen pipe, one at one side of the frozen spot and one beyond this, turn on the current and wait for the water to flow. The resistance of the pipe to the flow of

the current develops heat, just as is done by the filament of an incandescent lamp, and this melts the ice. One minute is the common time required to thaw out an ordinary service pipe. Three dollars is the usual charge.

The current needed is of large quantity and low voltage. In Sault Ste. Marie this current is taken from high tension wires in the street, where it has a voltage of 2,200, transformed to 110 volts and passed into the frozen pipes. The outfit consists simply of an ordinary transformer carried around in a sleigh and the necessary tools for getting at the pipes and making connections. The primary wires are bared and a connection made to the transformer through a water rheostat. It is not necessary to use any special precautions in taking the high-tension current to the transformer if there is snow on the ground, as this forms an almost perfect insulator for the wires.

Almost any pipe can be thawed out by the current from a 500-lamp transformer, but if necessary two of these may be employed.

Electric Fire Engine of Rouen, France

THE using of electricity to operate fire-fighting apparatus has long been urged, and to-day there are in this country several manufacturers who are at work perfecting electrical fire engines.

The great advantages which such engines would have in towns where electrical lighting, power or trolley currents are available in the streets are manifest. The engines would not have to have boilers or fuel, and could thus be made so light as to weigh but a few hundred pounds, and their cost, both at first and for maintenance, would be reduced in proportion.

Rouen, France, has an electrical fire engine made upon these lines, and its lightness and simplicity are well shown in the accompanying illustration. The entire apparatus is loaded, ready for use, into a one-horse cart.

The engine consists of a centrifugal pump and an 8-horse-power motor, which gives normally 2,000 revolutions per minute. The motor is adapted to the use of a continuous current of 525 volts. It is well covered, to prevent all penetration of water. Above are two reels. On one is wound the wire upon which the current is received. This is arranged to allow of a connection with a hook suspended from the trolley or electric light wires. On the other bobbin is wound the return wire, the free end being connected with a cast-iron block to be fastened to one of the street car rails. Beneath the reels is a compartment containing two circuit break-

ers, a circuit closer and a commutator.

The reels each hold 200 metres (656.167 feet) of insulated wire. Added to this is 200 metres of hose carried and 35 metres (114.83 feet), the distance to which the water can be thrown, and it will be seen that a range of 435 metres



Electric Fire Engine of Rouen, France.—Mounted by Fire Chief Lefebvre.

(1,427.16 feet) from the source of the power can be covered. The stream that can be thrown to the distance of nearly 115 feet is from an orifice of 18 millimetres (0.7 inch) in diameter. It has a volume of 350 liters (92.46 gallons) a minute.

The whole weight of this novel fire engine, with all of its accessories and two men on the seat of the cart, is but 1,040 kilograms, or 2,292.78 pounds. The motor and pump together measure about a metre in length and about half as much each way in width and height.

Following the engine to fires is a hose cart carrying 300 meters of hose, two lances, a ladder, an axe and other tools.

The engine was constructed after the ideas of Robert Lefebvre, Captain of the Rouen Fire Department.

Telephones for War, Business, Sickness or Pleasure

THE field of the telephone grows day by day. In cities it has become a part of almost every man's daily life—at home, in his office or shop. It is rapidly making its way into the countryside, bringing the isolated farm within speaking distance of neighbors and into the business and social circles of the town.

The farmer's wife in many progressive parts of the country can call upon the grocer to send up sugar for the waiting preserves, although five or ten miles intervene; she can enjoy a gossip or get a recipe from a neighbor, or send out for help. The farmer can trace his strayed or stolen cattle by the same agency, or learn the weather prospects from the post office in hay or harvest time. The postmaster can notify the farmer when registered or other important mail matter has arrived for him.

Afloat or ashore new uses spring up for the telephone continuously. In peace and in war its field still grows.

Every modern army has its field telephone sets ready to lay down or to connect with any existing system, whether they be those of barbed wire fences or telegraph lines.

On warships the telephone supplements and in reality supersedes the older systems of signalling from one part of

the ship to another, while in hotels, office buildings and apartment houses they have driven the old-fashioned speaking tubes into the background of almost forgotten things.

But the use of the telephone begins in such structures nowadays long before the buildings are anything more than mere frames of stone and mortar. Time was when a foreman or architect, wanting to give directions to a workman in a new building, could stand on the ground and easily make himself heard in any part of the building. Even as buildings grew in size it only required the mounting of a pair or two of stairs to bring the two men together. But with the growth of buildings first to eight stories, then to twelve, sixteen, and finally to near the thirties, this became impossible. Boys were brought into requisition to carry messages from one part of a new skyscraper to another, and messages were sent back and forth on the brick hoists. This was slow, costly, and involved much loss of time. Now the telephone does it all. Telephones are put up as rapidly as the framework advances, and no sooner are men at work on a floor than there is a telephone there to put them in touch with the directing forces.

Divers under the sea use telephones. Many a brave man encased in armor and helpless, has found death approaching him in its most awful form because his signal rope was caught between him and his watchful partners above. Now the submarine diver goes down to his work with a telephone and receiver all snugly fastened in his helmet, and at the other end of the connecting wire stands his partner with a telephone at his ear and a transmitter fastened to his chest, keeping in audible touch with him at every moment. A mere failure to get a prompt reply and the diver would be hauled up to safety.

Telephoning without wires is not yet beyond the laboratory stage of development, but the telephone has proved to be a most valuable assistant in telegraphy without wires. In fact, it may prove to be the means of assorting the messages coming from various stations at one time. The confusion which can be produced through various wireless systems or stations working all at one time within a small radius of one another was illustrated at the last international yacht races off Sandy Hook. Probably any one of the three systems then worked would have transmitted intelligible messages, but when the De Forest began to overlap the Marconi and the American to overshadow them both, endless confusion was produced.

With the development of many systems, the subject has become so serious that a convention has been called in Europe to settle upon international rules to regulate the use of the air.

Recently it has been announced by the De Forest people that by means of their telephone receiver their operators were able to distinguish and separate signals which were being sent at one time from one of their own stations and a station of a rival company, and to read them both. The delicacy of the ear is well known,

and it may become as easy for an operator to pick out and read various wireless messages as it is for an ordinary telegraph operator to hear and read his own instrument amid a din of hundreds, or to tell by the sound what person is sending a message.

In the sick room the telephone has proved itself a boon, indeed. Not only does it serve to summon the doctor promptly, but it also serves as a prescription in some cases. The sick room may be separated from the outer world by walls like those of dungeons or by miles of water. The patient may be in a pest house where none other may enter except the doctor and nurses, prisoners like himself. Yet this marvellous product of science can be placed at his bedside, and his wife, mother, children or sweetheart can talk to him and cheer him up at any minute of the day or night. A mere whisper that could not be heard at the bedside will carry his message miles away to the loved ones. Many a patient has found this a better tonic than all the drugs prescribed for him.

In speaking of the telephone in the sick room, do not let us forget that clever invention made by Dr. John H. Girdner, of New York, for detecting the location of any metallic substance, like a bullet, in the body. This is a telephone probe, operated by the feeblest of currents. The merest touch of the bulb at the end of the probe upon metal sounds a sharp "click" in the telephone at the operator's ear and he knows that he has found at least a part of what he sought.

Another of the latest uses to which the telephone has been put is for the control and despatch of cars and trains on electric and steam railroads. Beside the under trolley conduits of the Broadway, Third avenue, and other important city railroad lines are emergency wires which have telephone connections at every block or so. The repair wagons carry

the telephones. They are summoned by electric signals. As soon as they arrive at the scene of trouble they are ready to connect their telephones and talk to headquarters.

Farmers' telephones are used in great numbers in the middle West. At Lexington, Ill., there is one system which

has 320 telephones on it, and this connects with another with nearly as many more subscribers. These are but samples of scores of lines which in turn connect with the local systems of their central towns. These lines are all independent and are largely built and owned by the farmers themselves.

Concentrating Ores With Oil

THAT oil, common every-day oil, should have the power of selecting and carrying off valuable minerals and leaving valueless minerals severely alone, regardless of specific gravity, seems unreasonable. That heavy mineral oils, the most adhesively sticky of all the oils, should not stick to rusty quartz though violently agitated with it seems absurd; and that, at the same time, it should firmly adhere to smooth, shiny, slippery galena seems too absurd for further consideration. And when we are told that this is due to static electricity, and that, also, these results are accomplished in the presence of an excess of water, the fake seems complete.

Yet a commercially successful process for the concentration of ores by oil was invented more than three years ago, and has been in successful operation for more than two years.

Francis E. Elmore, of Leeds, Eng., is the successful inventor. His method combines many features before well known, and by the combination achieves success. In his process the pulp of ore and water and a cheap petroleum re-

sidium are introduced into a drum revolving on its horizontal axis. This drum contains a helical pathway, in which are baffle boards, and as the mixture travels this pathway it is continually agitated by means of these baffle boards. Out of the end of this drum the mixture passes to an ordinary spitzkasten or settling box, where the oil containing the concentrates floats and is drawn off at the top, and the rocky gangue and water are drawn off at the bottom. In practice it is found advisable to subject the pulp to a second and third time to this process, there being three revolving drums, one below the other. The oil, drawn off from the top of the spitzkastens, goes first to a centrifugal machine, where most of the oil is freed from the concentrates and is ready for use again in the drums. The remaining oil and concentrates pass to a second centrifugal machine, where a final treatment reduces the oil present in the concentrates to something like 1 per cent. of the weight of the concentrates. These processes are continuous and nearly automatic.



Power House of the Seoul Electric Company, Seoul, Korea.—The Largest Electric Plant in Asia.

Largest Electric Plant in Asia

THE plant of the Seoul Electric Company is said to be the largest single electrical plant in Asia. It was built for the Korean Company by an American firm—Collbran & Bostwick—who hold the property under mortgage. The company operates an overhead trolley road of some 12 miles in length and furnishes incandescent and arc lights for the city of Seoul. The generating machinery consists of two 120-kilowatt, double-current Westinghouse generators. The boilers are of the Babcock and Wilcox

type. The special point about the generators is that they produce direct current at 550 volts for use of the cars, and at the same time alternating current for the electric lighting. There are something over 1,400 incandescent lights besides the arc lights in use. High voltage alternating current is most advantageous for a city like Seoul, where lights are scattered over long distances. The consulting engineer is a Japanese, a graduate of the Massachusetts Institute of Technology. The railway is well patronized by the natives.



Hydro-Electrics in the Alps

By RENE DE LA BROSSE

Lancey and Livet

Fourth Article

Power House of A. Berges & Sons, at Lancey

AT Lancey, 15 kilometers from Grenoble, there has been conceived and created and put under industrial control the first large fall of a mountain stream of great power but of small volume upon the slopes of the massive mountains of Belledonne.

This massive mountain presents, it is true, some exceptionally advantageous conditions for this genus of industry. Its average altitude is considerable—amounting to 2,500 to 3,000 meters—and its slopes are sufficiently rapid for falls of great height to be created everywhere without requiring an excessive development of canals. The slopes are also enough wooded to retain the atmospheric precipitations and to escape the devastating action of torrents. The mountain receives an abundant quantity of rains and snows, varying from om. 75 to 1m. 60 per year, according to the altitudes, and it has upon it numerous lakes—Blanc, Crozet, Domenons, etc.—admirably situated to act as reservoirs and abundantly fed. Finally, it dominates immediately a rich valley, of which the altitude—200 to 250 meters—is remarkably low for a neighborhood so

generally elevated, and this makes possible the finding of sites for enormous vertical falls.

Such an assembly of favorable conditions is rare, even in Dauphin, and M. Tavernier speaks justly of it as marvelous

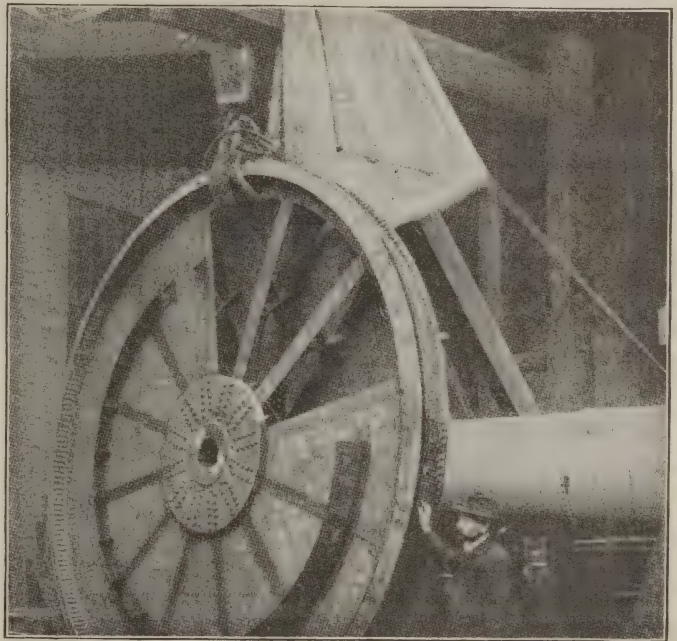

One of the Turbines at Lancey, Unmounted.

and exceptional, even in the Alps. But for centuries men lived in the lap of these riches without comprehending or suspecting their incalculable fecundity. To Mr. A. Berges belongs the credit of having first comprehended the value of the water powers of the Belledonne and then of making the first use of them. He is veritably the father of the white coal.

Arriving at Lancey about 1868, Mr. Berges established at the point where the modest stream of the Combe empties into the valley of Isere a paper pulp factory operated by water captured in pipes 200 meters above. This was considered a bold undertaking for the epoch. Criticisms were not lacking, but he responded to these by putting in a second pipe, obtaining this time a fall of 500 meters.

At the same time he busied himself with contriving means for regulating the flow of the stream, which was very variable with the seasons. It is not the tide which marks here the state of "low" water, but the "winterage." In summer the flow is sustained by an abundant melting of snows, but in winter all is frozen and the flow is reduced to a minimum. But the stream is, in great part, fed from the basin of Lake Crozet, situated at the altitude of 1,966 meters. A sort of rock sill divides the extent of this lake into two very unequal basins, the smaller being that of the outlet.

Mr. Berges began the work of regulation by uniting these two basins by means of a siphon. This brought into service a larger area of water shed, previously without employment. Although the reduced atmospheric pressure at this altitude limits the height at which the siphon can work to 6 or 7 meters, the result has not been less happy, for each

drainage of 1 meter represents a volume of water of 75,000 cubic meters on the whole surface of the lake. A little later Mr. Berges undertook to raise the water level by means of a dam surmounting the rocky sill, which serves him as a natural sluice-way. Long negotiations were necessary with two communes which owned pasturages bordering on the lake. The work is still but partially done. The dam has been raised to a height of 3m. 50 above its environment, but it is intended to raise it to a height of 30 meters.

In 1891 Mr. Berges doubled his power by leading to Lancey, under a head of 485 meters, the waters of the river Saint-Mury, issuing from Lake Blanc, at a height of 2,160 meters and flowing in a parallel valley. In 1897 he invented a method by which to draw off part of the unused waters held behind the rock sill of Lake Crozet by piercing under the sill a rock tunnel 230 meters in length. This empties at a depth of 23 meters under the surface, and during the period of low waters in winter forms a reserve of at least 1,500,000 cubic meters. Taking these results and comparing them with the possibilities in analogous regions of the mountain sections, Mr. Berges has estimated that France has a hydraulic wealth equal to 10,000,000 horse power. The 40,000 kilometers of our French railroads employ about

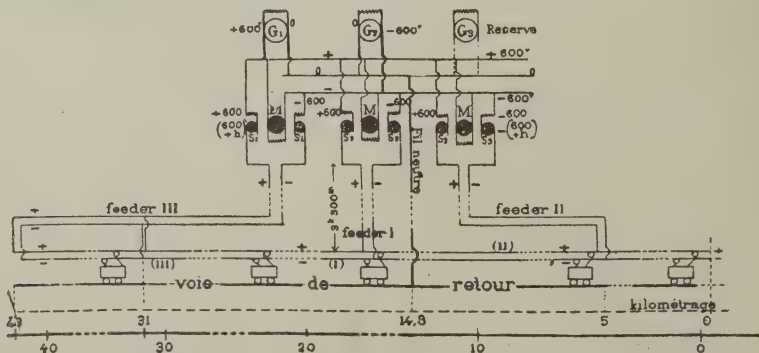

Distributing System at Lancey and Chapareillan.

4,000,000 horse power; the other industries employ about 2,500,000. This gives a total of 6,500,000 horse power produced by steam over the whole of our territory.

Finally, Mr. Berges has projected a complete system for the management of the lakes situated in the higher part of the two valleys of Lancey and Saint-Mury upon a plan which will produce a total fall of about 1,700 meters and give a return of 10,000 horse power. These lakes are fed by the water fall on a basin of 44 square kilometers.

The 10,000,000 of units from water powers that Mr. Berges predicts would lead, then, to a veritable revolution in our national industries on the day when they were ready for use. Perhaps Mr. Berges has not taken into sufficient account the altogether exceptional character of his basin in thus generalizing. One certainly does not often find, even in the Alps, an assemblage of circumstances as favorable as at Lancey, and one can affirm that exceedingly few mountainous basins in France would be capable of furnishing 10,000 horse power for 44 kilometers of area. But, even if the estimate were reduced one-half, fixing it at 5,000,000, one easily sees to what point the rational management of our hydraulic forces would augment the industrial riches of the country.

At its arrival in the power house the water, under its enormous head, rushes out of the orifices with a speed of 60 to 80 meters per second. This make special

apparatus necessary for its use. The orifices of the pipes were the subject of study, and they have been ingeniously contrived to resist the effects of these speeds and the wear and tear of sandy particles, happily rare, that are carried by the current. The motors have been redesigned in appropriate forms. Their diameters have been increased to realize at their circumferences a speed equivalent to that of the liquid; the size of the crowns has been diminished in proportion, and the motors have finally taken

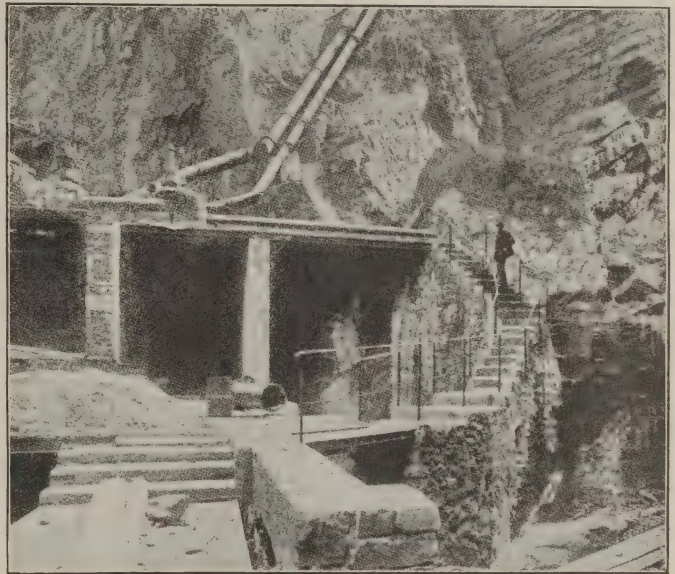

Power Conduit Where it Enters the Works at Lancey.

on the appearance of a large wheel 4 meters in diameter, with a rim of only 5 or 6 centimeters in width. The water acts upon the motors with lively force from jets 2 centimeters in diameter. There are four jets only for a motor of 600 horse power, and the visitor who enters this power house for the first time can scarcely conceive that such power can be produced by such small jets of water. But that which he will find there that is more instructive is not so much the intensity of effects as the great variety and the large number of services rendered.



Livet.—The Village, the River and the Power House.

It is now 30 years since Mr. Berges made his beginning with a modest factory for producing paper and wood pulp. To-day the factory of Lancey, provided with 12 turbines of 4,000 to 5,000 horse power, produces annually 3,500 tons of wood pulp, 4,000 tons of cellulose and 10,000 tons of paper. All the mechanical agents—saws, debarkers, defiberers, elevators, etc.—receive their energy from the hydraulic fall. Near them is a turbine specially devoted to the production of a continuous current used to electrolyze chlorate and to fabricate alkaline hypochlorates used to bleach the pastes.

A little further on four alternators produce a monophase current, which is distributed under a tension of 10,000 volts throughout a radius of 15 kilometers for the lighting of the valley of Isere. There are also here furnaces for making carbide of calcium, but these are not actually in service. Finally, right beside this paper factory a branch derived from the principal column of water under pressure leads to the motors of the workshop of the Compagnie du

Tramway of Grenoble a Chapareillan of which we will speak further on.

There is, then, at Lancey a complete series of varied employments such as one will not find elsewhere, at least not in the same degree, so that it is proper to say that the power house which was a cradle of this fecund industry of the "white coal" is in the lead in demonstrating to visitors in a practical way the many ways in which the power can be utilized. It is, moreover, the only instance of the ingenious management of lakes as has been described.

Finally, at Lancey light is distributed under the best conditions in price, since the farms of the neighboring country can have, for example:

	Francs per year.
First lamp, 10 candle power.....	25
Second lamp, 10 candle power.....	15
Three lamps (5 candle power each) at 5 francs.....	15

Making five lamps, 35 c. p., for... 55
This amounts to 11 francs per lamp, or to 1 fr. 60 per candle-power year.

Power House of the Tramway of Chapareillan

Near the paper factory of Lancey there stands, as we have said, a little building where the Compagnie du Tramway de Grenoble a Chapareillan produces the current which works its cars. This company is a client of Mr. Berges', who furnishes it, not with electrical current, but with liquid current in the form of water under pressure. This he furnishes at a price of 100 francs a horse power year, with a minimum rent of 25,000 francs, corresponding to a continued consumption of 250 horse power. Only the quantity of delivered water is measured, since the pressure remains constantly that due to the height of the column—about 500 meters. A meter is placed at the entrance to the power house. This water operates three turbines. Two only are used nominally. The other is held in reserve. The turbines are of the make of Brenier & Neyret, and are of 400 horse power each, with horizontal axis and open feeder. They run at 325 revolutions per minute. To each one is connected, by a Raffart elastic joint, a compound generating dynamo of the Creusot type 4 N, which gives a continuous current of 417 amperes at 600 volts. The efficiency of the turbines approaches 80 per cent. and that of the dynamos 94 per cent. Each unit is of about 320 horse power. In case of emergency the power house can develop as much as 800 horse power.

The generators, mounted in series form, with the two contact cables and the rails of the road, a three-wire

distributing system, with two falls of potential of 600 volts each, the road being in a neutral state. In this way a notable economy in copper has been effected, since the transportation of the energy is made under a tension of 1,200 volts, giving, however, but a difference in potential between each one of the cables and the earth of only 600 volts. This relieves the system also of danger. Finally, very ingenious boosters or survolteurs maintain constantly the voltage of the cables, notwithstanding the considerable variations of the line demand resulting from the inequalities of the road and the exigencies of operation.

This installation is the first example in France of an important collection (43 kilometers) of railroads obtaining energy from water under pressure rented from third parties. Such combinations would in many cases facilitate traction enterprises, and it is to be desired that they may become more general, and that tramway and railroad companies may be authorized with convenient guarantees to derive energy for operation from hydraulic sources already installed.



A Glimpse of the Generator Room of the Livet Power House.

Power-House of Cernon, Chapareillan.

We will simply mention the electro-chemical power house of the Cernon, at Chapareillan (Isere). It was used for a short time for the manufacture of carbide of calcium, but is now without employment. Right beside this little power house is another devoted to lighting the villages and hamlets of the valley of Isere. They both belong to the Societe des Forces Metrices du Haut-Graisivaudan; we will treat later of the lighting installations.

Valley of the Romanche.

The valley of the Romanche is particularly interesting at this moment because of the intense utilization of which it is the object. On a public road of twenty kilometers in length, between Vizille and Livet, are found not less than six large installations, with a total power of 30,000

to 40,000 horse power. It is assuredly the most industrial valley of the French Alps. It is only a few years since it was the most neglected and the least peopled. It offers the most striking example of a radical transformation accomplished in a quarter of a century by the utilization of mountain waters so justly called the "White Coal."

The Romanche is fed by the immense glacial reserves of Belledonne and of the Pelvoux. It is the theater par excellence of the industrial management of this "White Coal," so long left unrecognized. Electro-chemistry holds a considerable place there, but it does not alone occupy it. Two large paper factories exist there, one near Vizille and the other at Riouperoux. This last, to which the commission made but a very short visit, utilizes for eight turbines, two falls of 35 to 40 meters in height, with a total of 7,000 to 8,000 horse power.

Power House of Livet.

The power house of Livet will utilize under a net fall of 60 meters, the waters of the Romanche taken subterraneously at a distance of two kilometers from the village of the same name, from above Riouperoux.

The water intake is a lateral canal with a fixed detaining wall and an opening above this. The purpose of this arrangement is to avoid the gorging of the canal and the expense and interruptions of service which would be the consequence, and also to secure a partial decantation from the sand held in suspension, by only

admitting water to the canal from the surface.

The canal for the intaking of the water

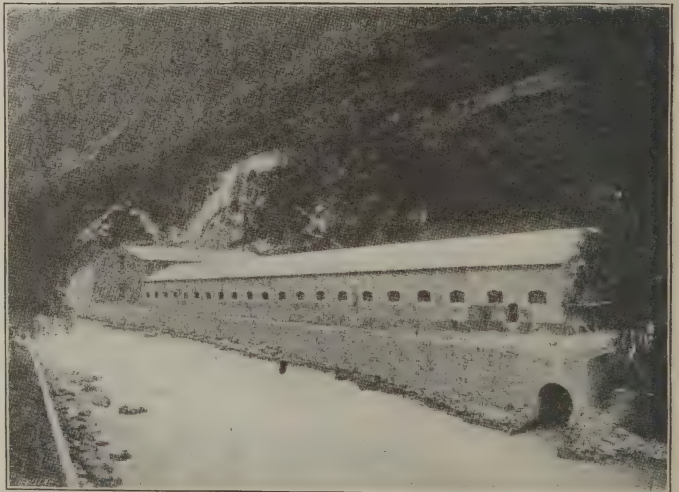

Power House of Livet.

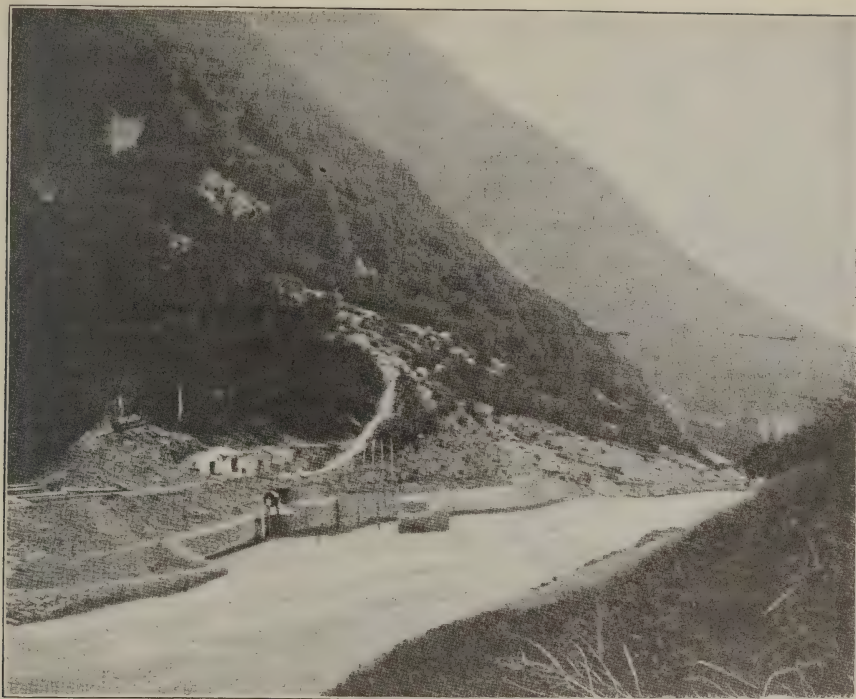

Water Intake on the Isere for the Power House of Livet.

is built at the side of the river immediately above the opening for the escape of the overflow. Its crest is lower than that of the dam by .60 meters, and higher than the bottom of the opening by 2 meters. Its length permits of a flow of 25 cubic meters per second, when the water is at the level of the crest of the dam. A guard grille inclined at an angle of 30 degrees arrests floating bodies. An overflow opening 6 meters wide, commanded by three gates at the level of the dam, assures the passing away of solids carried by the stream. Its foundations are of large rocks cemented. It is prolonged up the river to the place of intake, and also below far enough to prevent all undermining. Its slope of 3 degrees provokes a rapid current, and its depth suffices for the evacuation of all debris.

The dam, which creates but a small reserve basin, is built in the rapids of the ancient lake of Saint-Laurent, 144

meters from the bridge of the Aveynat. It is fixed. It was planned with a view to resisting the rapid current of the Romanche and to prevent the undermining of the overflow. Its form is that of the arc of a circle of 60 meters of radius. Its length is 30 meters. It is divided into three arcs, each 10 meters by 3 meters, and supported on piles. They rest on the abutment of the overflow opening and on the right bank. The whole is of masonry built of enormous granite blocks and joined with mortar and cement. First the piles were put in, then the lateral arches, and finally the central arch forming the key. The transverse profile of the dam presents a double curve which tends to augment the draft from the source and to weaken the speed toward the mouth. The height of the fall is thus lessened and undermining is less to be feared.

A chamber of water placed between the sluice canal and the subterranean in-

take effects a first decantation and regulates the rate of admission. A guard gate separates it from the conducting canal.

The conduit canal is about 2,000 meters long. It is tunnelled in the rocks. It is of circular profile, 3.75 meters in diameter, and 11 square meters in sec-

Three little oblique dams arrest the sand and empty it by means of pipes into the ancient lunettes d'attaque.

Water Chamber.

This work, built in the rock, stands 60 meters above the power house. It is divided into two parts. The first, pro-

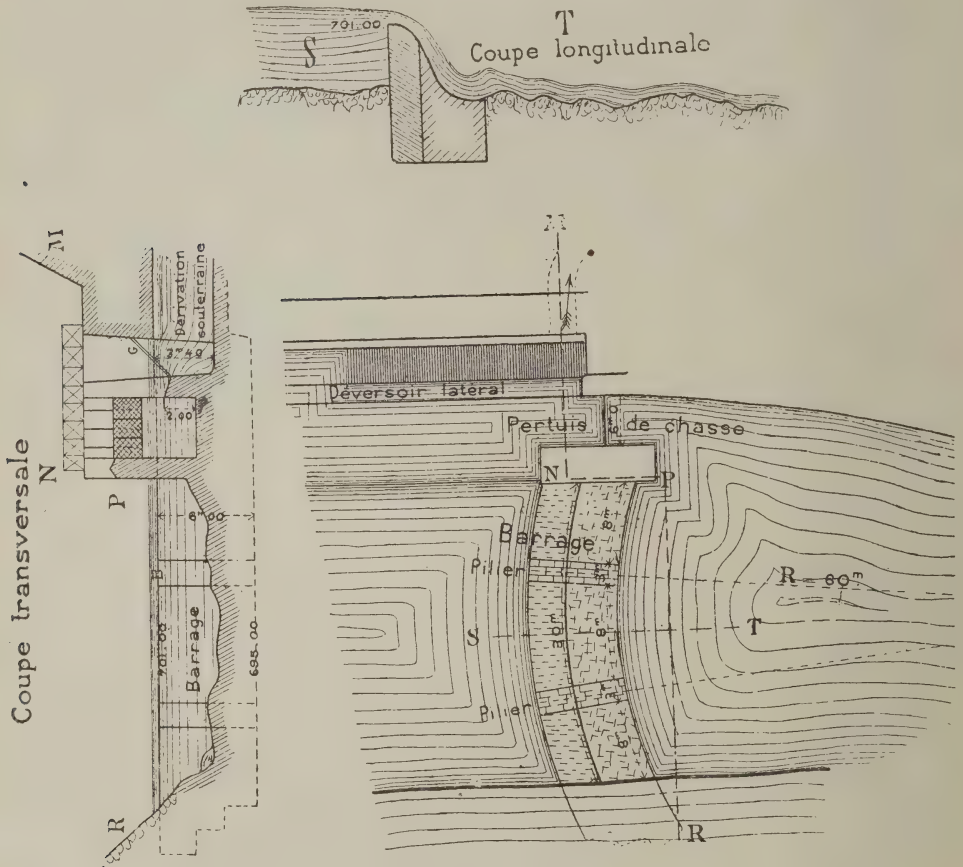

Plan of the Dam at Livet.

tion, with a slope of 15-10,000, giving the water a speed of 2 meters per second. The canal passes under several ravines or runs of avalanches, and so escapes their dangerous neighborhoods. It is entirely lined with cement. The thickness of this lining is .25 meters in the rocks, and .60 to 1 meter in the ground. The purpose of the lining was to avoid losses by infiltrations through the numerous crevices of the rock.

vided with two exit gates and a grille to arrest leaves and floating bodies, serves for a settling basin. It has above it a reservoir reconducting to the Romanche any excess of water not used by the turbines. The second part, which the water enters by flowing over the separating division, forms the water chamber proper. The entrance of the water to it is controlled by three vertical gates over the division. From the

floor of this chamber goes the power conduit in the form of a vertical well of 2.50 meters interior diameter.

This arrangement dispenses with vent ducts, which are necessary at the top of closed conduits, since the interior of the conduit is in direct communication with the atmosphere by its upper orifice, and no vacuum effect can be produced even in the case of an accidental sudden emptying of the liquid column.

The Power Conduit

This conduit, in place of being in the air, is built in the form of a vertical well, and further on it becomes a subterranean gallery. Thus it is perfectly protected from the possible fall of rocks, and it is not to be feared, for example, that a piece of stone falling on the metallic cylinder filled with incompressible liquid will perforate it like a punch. This is an important advantage, in a situation like that of Livet, and one cannot help felicitating the author of the plan upon such a practical conception.

The conduit itself is of annealed steel. The metal is not put to strains greater than 4 kilos per square millimeter. Its thickness varies from 5 to 15 millimeters. The pipe is 2.50 meters in diameter. The interval between the pipe and the encasing rock is filled with cement. This conduit can render from 9,000 to 10,000 horse power at the shaft of the turbine, according to the speed of flow. There are nine connections for motors. These

are made along the horizontal part of the conduit which goes the length of the power house.

An autovalve, a gate, and an emptying pipe allow the evacuation of sand, and of completely emptying the conduit for investigating and cleaning it. A manometer register indicates at every instant the interior pressure, and guards against danger from the high pressure.

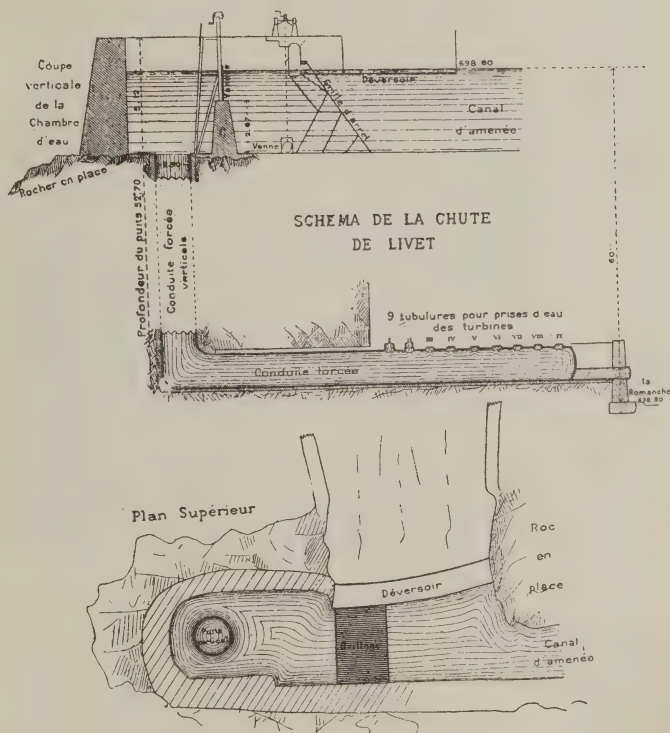

Canal and Tunnel at Livet.

Turbines

The establishment disposes of 9,000 to 10,000 horse power, and this can be extended to 15,000 with a flow of 25 cubic meters of water when the necessity arises. For this purpose, a second conduit can be built parallel to the first. At present the power house possesses five units of 1,250 horse power each, used to supply the electrical furnace, and two groups of 175 horse power each, for ex-

citing, lighting, and to operate divers motors.

The turbines of 1,250 horse power, of Neyret & Brenier make, are of the centripetal type, operated with suction and a constant stream. The turbines of 175 horse power (from the same constructors), are of the Girard type, with open free field and variable flow with a slide valve on the distributor. All lie horizontal. The large motors are driven at 350 revolutions per minute, and the small ones at 500.

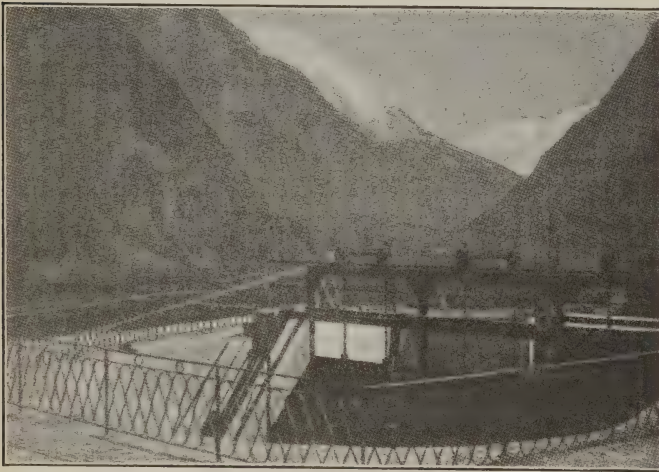

Water Chamber at Livet.

Each large unit is furnished with an automatic regulator to a hydraulic servomotor (Neyret & Brenier), which operates the admission valve and limits the duration of possible packing. The regulators of the small ones are very sensitive and assure a constant speed.

The guaranteed returns are 80 per cent. for the large turbines and 75 per cent. for the small ones.

The five large turbines are each connected by elastic joints to a Thury alternator with revolving field, giving a monophase current of 70 volts at a frequency of 46.6 periods, with a speed of 350 revolutions per minute. The fields have 16

poles. The alternators can bear a speed of 750 turns. Their guaranteed return is 92 per cent. The Thury exciters give at the double collectors 70 volts. The collectors of each can be coupled in series for lighting or for serving the motors for connected services.

Tailwater Canal

The canal which carries off the tailwater passes under the power house. It maintains the suction of the turbines by means of a little retaining dam, and serves besides to carry off the gas and the dust from a battery of pulverizers.

The industrial establishment comprises besides the building for machines, which is 12 meters long—

First. A building 70 by 22 meters for pits, a hall for crushing, repair shops and a covered shelter for railroads.

Second. A hall for furnaces, 50 by 15 meters, adjacent to the

hall for machines, and

Third. A building 105 by 15 meters, where the factory products are cooled, cased, packed and stored. Here also is a railroad as long as the building and the connection to the line from Vizille to the Bourg of Oisans.

All the interior needs are served by means of roads and wagonettes, and the arrangement of the buildings is planned for the operation of a continued and methodical cycle of operations, without countermarch or a false move, beginning with the arrival of the crude material, the crushing, cooking, cooling, breaking, packing, storing and shipping.

The power house of Livet, built specially with a view of utilizing on the spot an important part of its power in electro-chemical or metallurgic operations, could without doubt furnish other locations at a distance with current, for it will have at its disposition in winter a minimum of at least 4,000 to 5,000

horse power, and a total three or four times greater during the summer months.

The Society Electro-Chemical of the Romanche, which is putting up this beautiful installation, will certainly find without trouble advantageous employment for its power.

The Most Ingenious Single Mechanical Invention

What is the most ingenious single piece of mechanism ever made?

"The Electrical Age" desires descriptive answers to the foregoing question and will pay Five Dollars for each answer which it finds interesting enough to print.

For the answer which is finally considered the best Ten Dollars will be paid. Answers should contain from 600 to 1,800 words each, and should be illustrated with drawings or photographs.

The Sewing Machine Needle

To the Editor of "The Electrical Age":

Sir.—That which seems to me to be the most ingenious single piece of mechanism ever invented is the sewing machine needle. In the eye-pointed sewing machine needle one finds combined elements of inventive ingenuity which certainly do not exist in either of the inventions which so far have been declared by your correspondents as being the most ingenious ever made.

It is true that in the development of the wagon wheel, the screw and the piston, much skill and ingenuity have been demanded and displayed. To make each of these ingenious and useful devices capable of fulfilling the many demands and conditions under which they work, required great skill, but in only one example—that of the screw—does the resultant device remain true to your definition, viz., a single mechanical device. The screw meets this condition and the character of its every part has been ad-

mirably designed for use. Take for example the wood screw. From slot to point it is a marvel of ingenuity. The shape and size of the slot, the form and relative size of the head, the comparative length of the shank, the pitch and depth and shape of the threads and the form of the gimlet point, are each real elements in the claim made for it, that it is the most ingenious single piece of mechanism.

Had the wood screw as it exists today been created at one time by an inventive genius, I would think twice before trying to prove that there was any more ingenious single mechanical device in existence. But this was not the case. The screw is the result of long years of development and is more of a growth than the product of genius.

The sewing machine needle is, on the contrary, a product of pure inventive faculty. From the day that Elias Howe made his first crude sewing machine up

to to-day, it has had to perform the same functions, and it has undergone no material change in form.

"But, is the sewing machine needle such an ingenious device?" you ask. "It looks like a very simple affair."

There are few persons, even among those who make, repair or adjust sewing machines, who realize what a clever piece of mechanism the sewing machine needle is or how many functions it has to perform. It has been an article of manufacture for so long and its essential features have become so well fixed in the minds of mechanics, that few needles are now produced that do not meet the proper needs. A generation ago this was not so, and the sewing machine expert had to be constantly on the lookout for troubles from bad needles. In looking for these "bugs," he had impressed most strongly on his mind the ingenuity of the needle and of its inventor.

To the casual observer the operation of sewing by machinery is very simple. He sees the needle go through a cloth carrying a thread with it, and he sees the shuttle or its equivalent catch a loop of that thread and pass through it or hold it. He sees little more.

Now let us watch that operation with eyes aided by knowledge!

The point of the needle is just entering the cloth; about a quarter of an inch above the point is the eye. This distance is not an accident. It was fixed by allowing just enough length from point to eye to give easy entering angles to the larger sizes of needles and no more. Any more length at the point would mean that much more movement to the needle bar, and this added to by every stitch would pile up labor rapidly on the sewing machine user.

Now the eye of the needle is entering the cloth. If the eye were a mere hole through the needle ending squarely at the outsides, the thread would be

chopped off clean on each side of the needle at every stroke. To prevent this you will notice that the needle is grooved on each side above the eye. But you will also notice that on one side—that toward the shuttle—the groove is short, while on the other side the groove runs clear to the head of the needle proper. Do you think this is an accident? Put your needle in the other way and try to sew. "Chop!" will go your thread at the first stitch.

Watch the making of the stitch slowly and see what the needle does and why it has one groove long and the other short. Then you will see how ingenious it is.

Now the needle has reached its lowest point and begins to raise a little. As it raises the point of the shuttle approaches it. The raising of the needle produces a loop, the shuttle enters this loop, draws it open, passes through it; the needle goes up and the shuttle goes forward, the threads are drawn tight and the stitch is completed.

Is that all you saw?

Let me tell you what really happened:

As the needle went through the cloth beyond the short groove on the shuttle side, it forced the thread out into the body of the cloth beside it on that side. To do this the groove is made with its upper part graded up at an easy slope. The thread was forced out into the cloth to anchor it there so that it would have no tendency to rise again with the needle. Otherwise there would be a fair chance to miss making a loop for the shuttle to catch. On the other side the thread lies embedded easily in the long groove of the needle. This groove is deep as well. This also has its reasons. First, it is desirable that on this side the thread should rise with the needle, for no loop is needed on the side opposite the shuttle. A loop there would only be

a source of trouble. Next, however, comes the more important reason.

Watch the shuttle as it goes through the loop. Where does it get the necessary thread for the loop? It draws it down from the upper part of the machine through the long groove in the needle. That is why the groove must be long enough and large enough to hold the thread encased in it free from the cloth. When the shuttle has passed through the loop and long before the needle has risen to its highest position, this spare thread is drawn up again out of the way by the "take up." This also

is made possible by the long groove in the needle.

The eye-pointed needle was the invention of Batchelder. Elias Howe invented the combination of the eye-pointed needle and the shuttle to make a sewing machine. But as Howe had really to invent a stitch before he could conceive a machine to make it, and as he must also have had to work out the intricacies of the sewing machine needle, I think that to him belongs the credit of having made "The Most Ingenious Single Mechanical Device."

Arthur Price.

Yonkers, Dec. 10, 1902.

Heat, Man's Most Useful Servant

By JOSEPH MISKO, M. E.

HHEAT is a very interesting element. It is interesting to note that the 10 miles of air which immediately envelops the earth contains more heat than could be produced through burning all the coal that is beneath the earth's surface, including also all the wood upon our planet. It is also a fact that there is more coal in the air in the form of carbonic acid gas than in all the coal mines put together; and when we consider that at 70 degrees Fahrenheit we are in a temperature that is 410 degrees hotter than liquid air, which still contains over 100 degrees of heat, and that the difference between 70 and 212, the boiling point of water, is only 142 degrees Fahrenheit, then we can safely make up our minds that we are living in a very hot furnace. Some great inventor will make use of this fact some day to the great benefit of mankind.

All of this heat must come from somewhere, and according to our present

knowledge the primary source of all energy on the earth is the sun. I will not stop to discuss the various theories as to whence the solar heat originally came, and how the enormous waste continually going on is made good. I will content myself with stating that the compound rays emitted by the sun warm the earth, produce vast movements of water through evaporation and the formation of clouds, and so give us warmth and moisture, upon which the growth of the vegetable and animal kingdoms depend. Vegetation derives most of its food not from the earth, into which its roots penetrate, but from the air. The lovely mantle of green which adorns the productive portions of our planet is not intended to beautify alone; the vast surface of leaves exposed to the air has the property, under the influence of the actinic or chemical rays of the sun, of decomposing the carbonic acid in the atmosphere, of assimilating the carbon,

converting it into the ligneous parts of plants, and releasing the oxygen, which is essential to the life of animals. This is inhaled, and, again rejected, is restored to the atmosphere in the form of carbonic acid.

The quantity of carbon in the atmosphere is relatively small, varying from three parts by measure to ten parts in 10,000, but, absolutely, the weight of carbon thus diffused is greater than all the carbon in a solid form on the earth. The sources of carbonic acid are the exhalations of animals, the combustion of vegetable and animal substances, and emanations of a volcanic character. Wood contains from 46 to 55 per cent. of carbon, all derived from the atmosphere; and because the quantity of carbonic acid there is so small, the immense leaf surface is necessary to collect sufficient for the growth of the plant. By long continued contact with moisture and warm air, wood slowly decomposes by combining with oxygen, and is converted, according to circumstances, into vegetable mould, peat, lignite, or, finally, into coal, which, in the form of anthracite, consists of almost pure carbon.

The work done by the sun's rays in decomposing the carbonic acid of the air is very great. The energy which must be exerted to separate the carbon from the oxygen in carbonic acid is the same as that developed by the combination of the same elements in combustion, and has been determined by experiment to be equal to 14,544 units of heat per pound of carbon consumed. By an easy calculation it can be deduced that every ton of carbon separated from the atmosphere by the sun's rays in twelve hours involves energy represented by 1.058 horse power expended by the sun, but as this energy operates over an enormous leaf surface, its effects are quite imperceptible to our senses.

Mechanically the successes of the nineteenth century have depended upon the utilization of heat.

Could we see air and heat, men would have been led to many further discoveries, and many difficult problems in this connection would have been easy for inventors.

Heat exists in all materials as well as in air. If we take a given amount of atmospheric air, say in a bicycle pump, the air has the heat of the atmosphere, which is, say 70 degrees Fahrenheit. Now we push the piston to compress the air. Through compression a large volume of air becomes a small volume; the 70 degrees of heat cannot be squeezed out of the air as water is squeezed out of a sponge. A volume of air has been compressed! Pressure is obtained, but while doing this a large volume of heat also has been made to take a smaller compass? What happens? Air notifies us of its presence through pressure; heat tells us of its presence through degrees. Without pressure there is no air (vacuum); without degree there is no heat (critical temperature).

The compressed air in the bicycle pump gives us more pressure and more heat. It is possible to so compress air and its heat with it that it will make the pump red hot. On the other hand, if the pressure is entirely released to its starting point, it may seem like magic, but both the air and the pump will become instantaneously as cold as when started. By following this principle we will be able to produce artificial cold. Upon this artificial ice making is based. If we again shove the piston down in the bicycle pump and compress the air and thus make the air and the pump hot, and in this state plunge the pump and the compressed air in it into cold water, thus cooling the hot air in the pump to say 70 degrees Fahrenheit, its starting point, and then entirely release the pressure on

the air, it will be found that the pump will instantly become intensely cold, for the reason that the heat produced through compressing the air has been taken out, and by allowing the air, through the release of pressure, to take up its original volume, there is a lack of heat. Lack of heat is cold. A very easy proof of this can be had by using a "Sparklet" for carbonizing water. A small amount of liquid carbonic acid gas through release of pressure is allowed to become a large volume of gas. The water may be warm, yet by the discharge of the contents of the Sparklet into the bottle, water and bottle become ice cold instantaneously.

Making artificial ice or producing cold, consists of compressing air or a gas, thus making it hot, cooling the gas in its compressed state with water, and allowing this cold and compressed gas to expand back to its original size. The same gas is recompressed, recooled and expanded over and over again for years. By making ice you are making use of the cold produced, but if you do not make this use of the cold, and let the process continue, liquid air, solid air, or something even colder is obtainable.

The air, even at a temperature of freezing, still contains a great deal of heat. All the heat of all the air at the freezing point, if concentrated by compression, is enough to burn the City of New York off the earth in five minutes; it would melt all the iron in the world in a few seconds; it would make steam for all the boilers and engines of the earth for years.

Having satisfied ourselves that there are other ways to produce heat than to have fires, and that there are other ways to produce cold than by means of having ice around, we are now ready to understand the fact that by burning a fire we not only produce heat, but cold as well. Let us see how this happens. Suppose

we burn a gallon of oil. The gallon of oil will become, first, vapor, then gas, then finally a product of combustion. In this form it is at least 500 times as large as when it was oil. You have burnt the oil, you have produced heat, but you have allowed it during the process of burning to expand, to become something very large; you have the ice machine in the midst of your fire. The heat-producing qualities of the burning oil are, it is true, greater than the cold produced through its expansion, so the heat wins the contest, but at a very large loss. If this cold-producing quality of a fire could be prevented, there would be no trouble to produce undreamed-of degrees of temperature.

If we could burn the gallon of oil, and instead of allowing it to expand to a volume of 500 gallons of gases in the open air, we could provide a chamber which has a capacity of only 250 gallons, the products of combustion, instead of being at an atmospheric pressure of 15 pounds, would be under a pressure of 30 pounds to the square inch. The heat would be condensed as well as the gases. Now if we make the chamber so small that instead of 30 pounds we create 200 pounds pressure, a correspondingly high degree of temperature would be produced.

Pressure has a great deal to do with heat. Pressure controls the boiling point of all liquids. Water in a vacuum or without pressure on it, boils at a lower temperature. On high mountains, where the pressure of the atmosphere is less than 15 pounds, the mountaineers cannot cook their beans or potatoes, as the water boils away before it gets hot enough to cook with it. With enough pressure and a strong enough vessel to hold it, it is possible to heat water red hot without boiling it. On the other hand, it takes but little heat to raise the temperature of water from freezing to the boiling point, but it then takes a great

deal of heat to tear the molecules of the water apart and convert it into steam, yet the steam will have the same temperature as that of the water. The heat goes into expansion, and as steam is 1,700 times as large as water, a great deal of heat is needed to make up for the increased volume.

Heat can be produced slowly or rapidly. The iron that rusts and the food that is digested in our stomachs are both burned slowly. Oil on the fire burns millions of times faster than the iron rusting. Exploding gunpowder burns many times faster than oil on the fire.

It is the oxygen of the air that does the work, but only 21 per cent. of the air is oxygen. The percentage of nitrogen and the percentage of carbonic acid gas do not help. For that reason a great deal of air is needed to make a fire burn, and the largest loss which steam engineers encounter is the heating up of this 79 per cent. of neutral gases to the temperature of the fire and then having to send them off through the chimney. Coal, in burning, consumes two and one-half times its weight of oxygen. The

neutral gases are four times as great in volume. The expansion of the gases also absorbs a great deal of heat. For these reasons the engineer looks at the chimney with a sorry eye.

As it is true that nothing leaves the earth, and that there is more carbon in the air than beneath the earth's surface, it does not seem that there ever needs to be a fuel famine. Future inventors will probably find a means to rob the air of its carbon. There are also other fuels than carbon. Water by weight is one part oxygen and eight parts hydrogen. If these two gases are separated and again brought together and ignited, enormous heat is the result. To separate the water into these gases with our present knowledge, costs more than the value of the heat so obtainable, but some day an inventor may discover how to do it for a less cost than the value of the heat so obtainable. Such a discovery would soon make the inventor a billionaire. We are living in a very wonderful age, and for that reason anything may be expected.

A Novel Method for Climbing a Tall Chimney

The steel smokestack of the electric light plant at Canton, Pa., 100 feet high, needed painting. The fireman made a kite or parachute which fitted loosely inside the stack. He attached a string to the parachute; the draft in the stack carried the parachute up through the stack and out, the parachute coming down outside. A small rope was next tied to the string and pulled up, and finally a strong rope, with tackle, was arranged to haul up a man to do the painting.

To Unite Cast Iron

To unite ordinary cast iron is not an easy task, but it may be done, if one has luck, by boring a dozen holes in the parts to be united, then secure well and place about the break an abundance of filings of good pig iron, some wrought iron filings and also some of steel, says "Mining and Scientific Press." Lute with fine clay and place in fire (before luting use any good flux, borax, etc.); heat until the filings melt and fill all the cavities. Let remain in the fire until fire goes out and the metal is cold, then remove and clean up.

The Ellipsograph

DRAUGHTSMEN recognize that no figure is harder to draw correctly than that of an ellipse, with its constantly changing curves. Correctness may be approximated by the careful use of curve plates, but it is safe to say that no two draughtsmen, working independently, would hit upon identical lines in drawing ellipses of identical measurements lengthwise and across.

No glass cutter would venture to cut a mirror or pane of glass to fit an elliptical opening, though he had these measurements, unless he had also an exact tracing of the space to be fitted. No worker in wood or metal would attempt to duplicate a part made in this form without exact drawings. If the part were square, oblong or round, he would

need nothing better to guide him than figures and angles.

This is merely suggestive of the possible value of a new mechanical device, called the "Ellipsograph," which has been recently patented. This machine enables its user to describe at will, and to exact measurements, any figure lying between a straight line and a circle, through all the variations of the ellipse. By other adjustments easily and quickly made the axis of each pattern may be changed to any angle or the working center shifted from place to place, making possible the production of intricate patterns of the most delicate and accurate sorts, such as engine lathe engraving machines have heretofore been employed to produce.

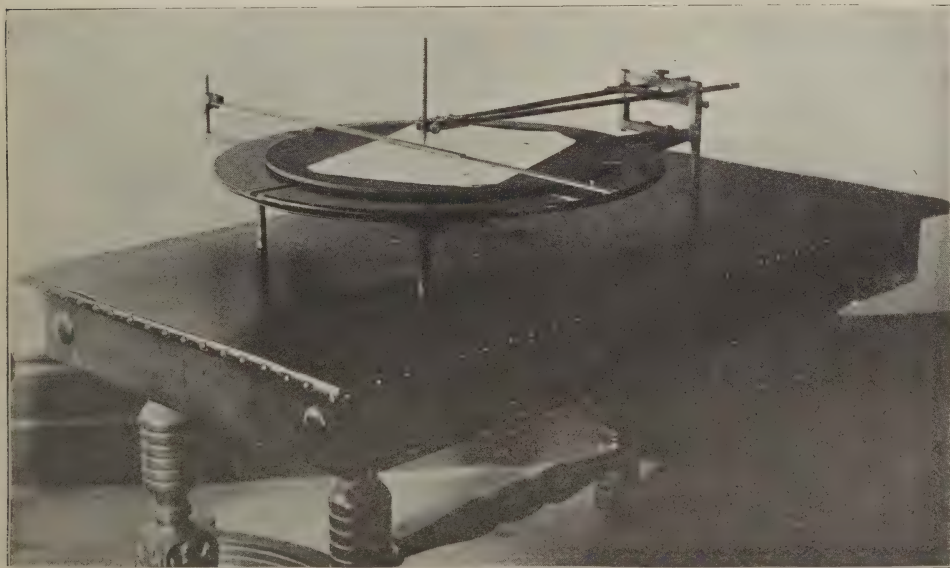

The Ellipsograph, a Remarkable New Device for Drawing, Engraving, or Cutting Difficult Figures.

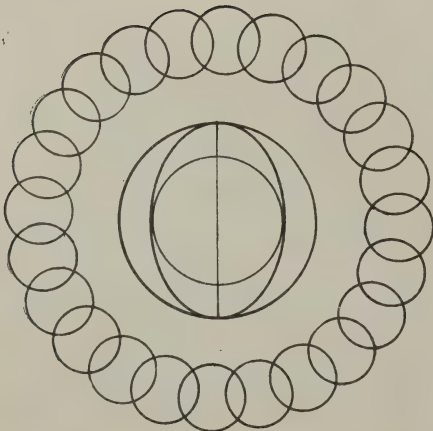
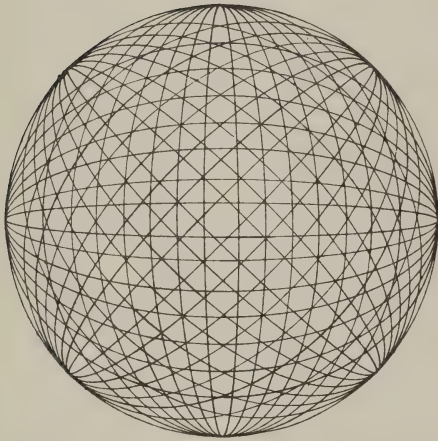
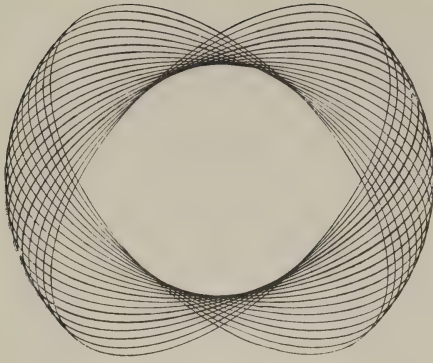

As used by draughtsmen the machine carries a pencil or pen, and produces drawings only, but, without making other changes, the drawing tools can be replaced by etching points, engraving tools, diamonds, wheel glass-cutters or knives, and the work be traced upon glass or metal. Glass plates can be cut to measure, or such articles can be produced as picture mats or other light work where ellipses, ovals or circles are needed. Any figures cut or drawn by one of the machines may be exactly duplicated anywhere else with another machine and by measure alone.

The machine itself is very simple. The parts which control the formation of the figures consists merely of two slotted bars, which may be set in various relations to one another. When their centers coincide and are placed exactly under the center of the circular working table circles are produced when the table is revolved. When the two bars are at the other extreme of their positions, the revolving of the table carries its central portion in a straight-line movement under the pencil arm. Between these two extremes ellipses are formed.

On the main working table lies a second table, to which the work is

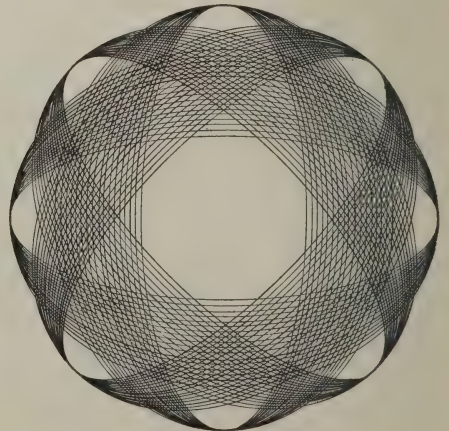

Some Drawings Made with the Ellipsograph.

fastened. This table is clamped to the first. By loosening the clamp and shifting the upper table about on its center the axis of the work is shifted. Thus, cross lines may be drawn, or one set of ellipses after another drawn over one another about a common center. This second table may also be shifted out of the center of the main table when other centers of work are to be reached or odd figures are to be drawn.

The pencil or tools are carried by a jointed arm which turns down over the working table. This arm can be readily shifted so as to move the working point to any position between the center and the edge of the working table. This adjustment fixes the outside measurement of the line, circle or ellipse to be made. The other adjustment, to determine whether a line, circle or ellipse shall be made and to fix the width of the ellipses, is made by means of a jointed scale rod which turns down across the face of the working table at right angles to the pencil arm, and a thumb-screw under the machine.

For mechanical purposes these details are, of course, modified, but the principle remains the same. By means of a micrometrical adjustment as many as 450 distinct lines to the inch have been drawn with the machine.

For architects, designers, glass and mirror cutters, lithographers, engravers, etchers on glass, silver, copper or steel, picture and photograph mat cutters, brush makers, wood carvers, and, in short, persons engaged in any occupation where circles, ovals, ellipses or other curves must be produced frequently and with accuracy, the Ellipsograph promises to be of great service. The machines are made in several sizes. The smaller permits the tracing of a circle 22 inches in diameter, and the larger the making of a circle with a diameter of six feet.



Workmen who know the kinks of their trades, the tricks played by machines and tools, and ready methods for meeting shop emergencies, are invited to contribute to this department.

The Care of Belts.

WHEN quick-running electric motors are connected to shafting with belts, the belts require to be kept in the best of condition, if good results are to be obtained. This is due to the small size of driving pulleys generally used. The smaller the pulleys the more trouble there is apt to be with belts. Generally the most satisfactory solution of such belt troubles is to substitute larger pulleys.

The function of belts is so simple that often little attention is paid to them until they are rendered practically worthless by neglect. The quality of the material used in their construction and the condition in which they are kept have a decided effect on the production of a shop or mill. The best quality of leather belting is the cheapest in the end, if it receives good care. The efficiency of a belt depends on how closely it hugs the pulleys, so that air may be excluded from between the two pulleys. Of two similar belts, one put on with the flesh side to the pulleys, and the other with the hair side to the pulleys, the latter will be the more effective. The smooth hair surface practically excludes the air, while the uneven flesh side allows a quantity of air to remain between, thereby partially destroying its adhesion to the pulleys.

Sewing belts has to some extent the same effect, as the belt lacing forms an

uneven surface. This causes a slight loss of effectiveness, and when high speed is used the loss is perceptible. Belts should never be laced, especially large driving belts. The best result is obtained by forming a taper joint, which must be cemented, then there will be no uneven place to cause slipping. For small belts the ends should be cut square, brought together as closely as possible, and fastened by a malleable iron belt hook.

The ends of the joints should run with the pulleys, and not against them, as in the latter case the rubbing of the belts on the pulleys will be liable to cause the ends to roll up. The effectiveness of the belts would thereby be destroyed and their life shortened. The best results are not always obtained from a tight belt. When too tight, a belt binds the shafting, and causes undue friction in the bearing, which consumes power. A large belt should always be run a little slack for the purpose of getting the benefit of the weight of the belt added to the driving power. If the ends of the belt are not square when hooked or joined together, one side will be longer than the other, and the belt will run to the tight side. If the difference in length is much, trouble will be found in keeping the belt on the pulleys.

A similar effect is produced if the shafting is out of line, or if the machines are out of line with the shafting. Some machines can be run with slack belts and produce more work than others of the same kind in the same room which must be run with tight belts, but it should be the aim of every overseer to have his belts run as slackly as possible without slipping. When belts have been neglected, especially driving belts, the first notice they give of the fact is that the machines do not run as smoothly as formerly, and the production falls off. Uneven speed is said to be the cause.

This is true; but the uneven speed is the result of neglecting the belts, and is not due to the engineer. When the belt becomes hard and dry, it loses its pliability, and will not bend as readily; consequently it does not hug the pulleys as closely as it should. If dirt and dust are allowed to accumulate on the running face of the belt, it will lose its adhesiveness, and slip. The unpliant or slipping belt will wear unevenly, so that the evil is increased.

Dirt should not be allowed to accumulate, but if it has, it should be scraped off and the belt should receive a coating of some good dressing. The adhesiveness of a belt depends on its pliability, and that cannot be maintained without the use of a dressing of some kind. Lubricating oil is better than nothing. Castor oil is a highly satisfactory dressing. Under no circumstances should an operative be allowed to soap a belt to increase its adhesiveness. It serves the purpose for a short time, but acts as a dust catcher, and soon the belt will accumulate a mass of glazed dirt which will seriously interfere with its adhesiveness.

Curious Experiment in Tempering.

By ALOIS PLATT.

AT a meeting of the New York Watch Makers' Society some years ago a discussion arose as to the value to be attached to the color method in drawing temper on steel tools. The writer at that time made an experiment which is here described by request, without comment. If it serves to bring out expressions of opinion on the subject of temper the object of the writer will be attained.

Take a round or square piece of steel; harden it, and then, after polishing, heat it until it takes a yellow shade. Polish half the plate, and heat it again until the

polished portion becomes yellow, and you will find the part which was yellow is now red. Then again polish half the yellow and half the red portions, and heat the plate until the polished part becomes yellow. You will then find the part that was first yellow—and which afterward turned red—will be blue, and the second portion, which was yellow,

will now be red and the polished part will be yellow.

Again polish part of the blue and yellow portions and heat in the same way, and you will find that what was blue will now be gray, what was red will now be blue, what was yellow will now be red, what was polished plain will be yellow.—“Sparks from the Anvil.”

Ozone Used to Purify Air and Water

OZONE as produced by nature through the effect of lightning discharges upon the oxygen of the air is the great natural purifier of the air, and the same interesting gas produced artificially bids fair to become an important factor in destroying impurities in the air we breathe indoors and in the water we drink.

On the Elder-Dempster steamship Lake Simcoe a device of this character is in use to clarify the air. The steerage, with 500 persons, is by this means kept refreshed and odorless. The apparatus is an invention of Colonel Josiah Harris, F. R. G. S. It is all compactly disposed in three boxes, which can be placed on any ordinary dining table. It is operated by direct current taken from a lamp socket. This is converted into alternating current by a small rotary or motor-generator in the first box. A transformer in the second box raises the current to a high potential. The ozonizer proper is contained in the third receptacle. This is a cabinet measuring about 18 inches each way, containing at one end a revolving fan, and at the other end two screens. One screen is positive and the other negative. They are made of

copper netting, and are each covered on one side with many little spikes or points. The screens are so arranged that these points lie just opposite one another, and it is between them that the electricity passes, setting up a succession of discharges. The air is forced through these screens by the fan, and, in passing, the ozone is generated.

Another application of ozone, on a more ambitious scale, is that of the Vosmaer-Lebret system for sterilizing water on a large scale. The system has been in use commercially at Schiedam for about seven months for 11 hours a day without interruption. Alternating current of 100 periods and 10,000 volts is used. The ozone is formed by means of dark discharge, without any solid dielectrics. Through the ozonizer dried air is driven at a speed of about 40 liters a minute. Three and one-half milligrammes to five milligrammes of ozone per liter is obtained. The ozonized air is then pumped into the sterilizer, entering at the bottom and leaving at the top. The cost of ozonization is said to be from one-sixteenth to one-eighth of a cent per cubic meter.

Triple Rainbows in a Green Sky Seen at Like Hours in France and America

METEOROLOGISTS will find something interesting to explain in the fact that on August 24 last, at the same hour of the day by the clock, there were exhibited in the skies in France and in New Jersey a curious series of phenomena which were so nearly alike that a description of what was seen in the one place is almost word for word a correct description of what was seen in the other. Knowledge of the coincidence of the phenomena was gained by the reading in this country in a copy of "La Nature," of Paris, of a communication made to the Academy of Sciences in France by Em. Roger, Director of the Meteorological Station of Chateaudurr, France.

Mr. Roger says:

"The day had been partly rainy, and in the afternoon it had rained without ceasing, but toward evening about half an hour before sunset the rain was about ended, and in the western horizon a long and very narrow clear space permitted the sun to be seen for a few moments before it reached the line of the horizon. It was then about half-past six o'clock.

"The clouds immediately began to take on, in proportion as the clear space became larger, tones most bizarre in effect, and opposite to the sun, in the east, even to the horizon, the thick curtain of black and rainy clouds, and even the distant background of the landscape, assumed a very pronounced greenish tint, as if they had been illuminated by an electric lamp.

"This effect of light, already singularly strange, became still more so a little

later. At about seven o'clock, during the five minutes which included the moment when the sun disappeared below the horizon and sent us its last rays, the sunlight itself, reflected on the top of our buildings, appeared green, and this time of a deep green which was quickly lost in shadows. Added to this, during the interval of time when this fairy play of light was produced, between 6.40 and 6.50 o'clock, a rainbow appeared in the east. It was an incomplete bow, for it had but two courses only touching the earth. These were visible to a considerable height above the horizon. These portions of the rainbow appeared very large, the habitual colors composing them being repeated simultaneously at least three times. Those portions of the triple rainbows situated to the southeast were much more beautiful than those to the left. The triple rainbows were not visible for any great length of time, and it seemed to us that they were either destroyed by the green light emitted by the sun, or at the least that they were much weakened by it."

The counterpart of these phenomena in this country was seen at Red Bank, N. J. The triple rainbows were somewhat more pronounced than were those described by the French observer, and the sky contained a most remarkable color effect, impossible to describe; but the strong green color was there as it was also in France, and this was the dominant color which prevailed as the sun sank and the rainbows were obliterated.



New Wireless Telegraph Tower at Navesink Highlands, N. J. Its Top is 360 Feet Above the Level of the Sea.

New Wireless Telegraph Station at the Navesink Highlands

WIRELESS telegraph stations are being multiplied rapidly, and are fast becoming conspicuous objects in our landscapes. A new tower, to be used for the receipt and transmission of wireless messages, which is now nearing completion at the Highlands of Navesink, at the entrance to New York Harbor, has attracted much attention during its building. Thousands of excursionists passing the Highlands in the Shrewsbury River boats or at sea have noted it as it reared its head higher and higher, and wondered for what purpose the tall structure was to be used. The new tower is the property of the Consolidated Wireless Telegraph and Telephone Company, of Philadelphia. This com-

pany is the holder of patents formerly held by the American Wireless Telephone and Telegraph Company and some 50 odd other patents. Among these is the patent issued to Prof. Amos E. Dolbear, which, it is claimed, is a fundamental patent covering the principles of wireless telegraphy and telephony.

The Highlands of Navesink tower stands beside the celebrated twin lights, which mark for the mariner the entrance to the finest harbor of the world. These lights are usually the first to greet the newcomer to the Western hemisphere or the returning visitor from Europe. The new wireless tower is, however, so tall and conspicuous as to be now the first

object likely to catch the eye of one looking westward from the sea. It stands a little to the south of the twin lights with its base 210 feet above the sea level. The tower itself is 150 feet tall, making its top reach an altitude of 360 feet above the sea.

At the very top, and held so high up that it commands a clear view even over the hills of the Navesink, is a little observation room. Here it is expected that there will be housed the ship-news observers of one of the big telegraph companies. These are the men who keep constant watch and vigil, sweeping the sea with telescopes to get news for anxious persons of the sighting of ships due from all over the world.

At the bottom of the tower and standing within the quadrangle formed by the four corner pieces of the structure is another room. In this are to be housed the wireless telegraph operators. Here will be an engine and dynamo and all the other electrical apparatus for sending or receiving wireless messages. The tower is built of timber. It is 40 feet square at the base. The little house at the top is 6x9 feet in area. Standing out from the top of the tower are eight timber arms. From the ends of these will be suspended wires to receive the messages. These wires will fall from the arms to the bottom of the tower, where they will be con-

nected with the transmitting and receiving apparatus.

The Consolidated Wireless Telegraph and Telephone Company claims to have seven systems of wireless telegraphy, each different from the others.

"We are sending messages daily 67 miles, of which 42 miles is over land, and this has been going on for nearly a year," writes one of the company's officers to "The Electrical Age." "This is the largest land station in the world. We also have a boat equipped for wireless telegraphy, the only purely simple wireless telegraph floating station in the world. She is now at Sag Harbor, Long Island. Our system which is now used is so simple that only four pieces of apparatus are used, and any person who can read the Morse Code can send and receive messages. Our apparatus is so simple that it costs for each station only about \$700 complete. Our stations now working are at Lewes, Del.; at Cape May and Atlantic City, and we have one nearly completed at Quoque, L. I., besides the tower at Highlands, N. J.; other stations in contemplation are at Chatham, Mass.; Nantucket, Hatteras, Cape Charles, Key West and Havana.

"One of our sub-companies has stations at Catalina Island, Cal., and at San Pedro, 37 miles apart, from which they send 261 messages in a day."

Cement for Leather Belts

A good cement for leather belting is made by working together 10 parts of bisulphide of carbon, one part of oil of turpentine with gutta percha, forming a thick paste. The leather where the

cement is to go should be unrolled and roughed, and when the cement is put on, the ends should be pressed together closely till the cement has well dried.

A Live-Fish Transportation Tank

RESTOCKING lakes and rivers with fish is one of the most valuable works undertaken by the public authorities in recent years. One of its difficulties lies in the transportation of live fish.

Fish must breathe, and the small amount of free oxygen contained normally in water is soon exhausted when many of them are crowded together. Then they drown.

The ordinary manner of shipping the small fry in this country is in milk cans. Attendants go along and keep up the supply of air by dipping up portions of the water and pouring it back in a thin stream from a considerable height. The stream entrains minute bubbles of air, and carries them down into the body of the water. This method is expensive, and only effective for comparatively short journeys.

A new apparatus for carrying live fish has been devised in Switzerland and patented by Gmur, Maurer & Wiget, of Lucerne, in which a tank of oxygen is provided to keep the fish alive. This is described as follows by Henry H. Morgan, United States Consul at Lucerne:

“The cylinder attached is charged with compressed oxygen, and automatically allows the required amount of gas to descend, by means of a tube, under a very fine wire gauze, which is a little above the bottom of the barrel or cask. The pressure of the oxygen keeps the water from entering the space between the screen and the bottom of the barrel,

and allows only a small portion of the oxygen to penetrate at a time. The gradual escape into this space is greater than the outlet through the wire gauze, with the result that when the space becomes greatly charged with oxygen gas, and the force of the water above is no longer able to hold it, it rushes into the tank or barrel with such force that the fish are turned over and over. The most delicate fish can be packed in these tanks in great quantities and will keep alive for 36 hours with the present device; but it is expected that with a larger cylinder of oxygen the length of time will

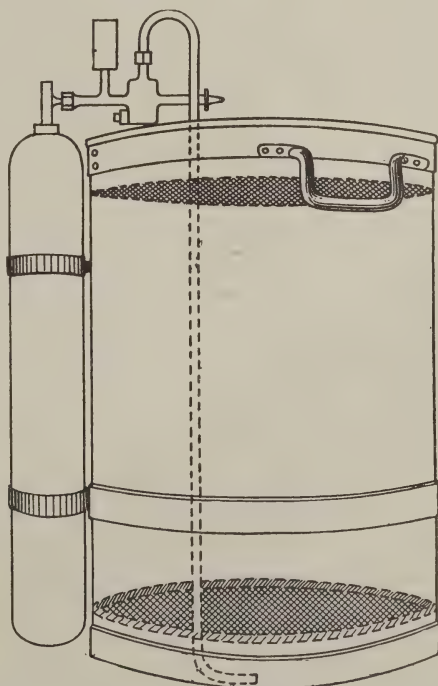

Can with Oxygen Attachment for Carrying Live Fish.

be increased. Shell fish and eels could be packed like sardines in a tin.

"As the cylinder containing the compressed oxygen gas works automatically no care is required during the transportation of the casks.

"Large quantities of brook trout and other fish are being sent from Switzerland to other parts of Europe by means

of this device, and as an illustration of the advantages of being able to transport the fish alive Messrs. Gmur, Maurer & Wiget inform me that in Vienna, for instance, they receive 8 crowns (\$1.60) per kilogram (2.2 pounds) for live brook trout, whereas for the dead ones they only receive 3 crowns (60 cents)."

We Pay as Much for Electricity as for Bread

By WALTER J. BALLARD.

THE use of electricity for lighting in the United States began in a small way, as recently as 30 years ago, with the manufacture of small machines for arc lamps, followed about 10 years later with equally modest machines for incandescent lighting. The ordinary arc dynamo would carry from 25 to 50 lamps, requiring 50 horse power to drive it, and the incandescent machines would feed about 1,000 lamps of 16 candle power, and use 120 horse power.

We learn from Bulletin No. 245 of the twelfth census that the adoption in 1885 of practical methods for utilizing the alternating current changed the whole aspect of affairs, and the change first became publicly apparent in the eleventh census. At that time, 1890, in the State of New York only 3,340 incandescent lamps, in isolated plants, were operated with alternating currents, while of the 1,264 dynamos in service in central stations only 189 were of the newer alternating type. Now we have the huge 5,000 horse-power, two-phase dynamos in operation at Niagara, while others of

10,000 horse power, the largest ever built, are contracted for. Further, the 5,000 horse-power alternators at Niagara develop current at 2,200 volts, which, by means of transformers, is raised to 11,000 to 22,000 volts, and transmitted to Buffalo for the use of trolley lines and other industries.

Since 1890 has been developed the vast electric street railway system, and, more recently, plants for charging the batteries of electric automobiles have sprung up. Dynamos have come into use instead of primary batteries in busy telegraph and telephone offices. In addition, there is the large increase in the use of electric machines for mining and general power purposes. For electric work generally no less than 17,539 patents have been taken out in the last 25 years.

We must also bear in mind the rapid strides we have made in the last 20 years in the manufacture and use of electric apparatus and supplies for our telegraphs, telephones, stock tickers, burglar alarms and other electrical conveniences and necessities.

In electrical apparatus and supplies generally, but excluding the hundreds of thousands of wood, iron and steel poles,

the increase in manufacturing between 1890 and 1900 is shown in the following figures:

	1890.	1900.	Increase. Per Cent.
Establishments	189	580	206.9
Capital	\$18,997,337	\$83,130,943	337.6
Wage earners, all kinds	9,485	45,877	
Total yearly wages and salaries	5,366,188	24,703,456	
Miscellaneous expenses	1,154,462	6,788,314	448.
Cost materials used	8,819,498	48,916,440	454.6
Value, yearly product	19,114,714	91,348,889	377.9

The number of wage-earners ranged from 50,389 to 32,582, averaging 40,890, including 6,158 women and 582 children under 16 years of age.

Mr. T. C. Martin, the expert special agent of the census, who prepared the report, says:

“At least one explanation of the rapid rise of the United States to its present position in international affairs and among the manufacturing nations may be found in the willingness of its people to pay as much for electricity as for

bread—about \$7 annually per capita of the 75,000,000 population.”

The manufacture of dynamo-electric apparatus is carried on in 20 States, with New York leading. The average price per horse power of dynamos of various sizes up to 5,000 horse power has been nearly \$14, but the 10,000 horse power dynamos have been sold at a price approximately only \$7 per horse power.

The capital of \$83,130,943, it may be noted, is producing a yearly product greater than itself by \$8,000,000.

Invisible Artillery

AN interesting experiment, the idea of a military officer, has been tried at Aldershot, by which it is hoped to render artillery inconspicuous against all kinds of backgrounds. A battery of six guns, with their limbers, was painted rainbow fashion, with streaks of red, blue and yellow, the whole blending, at a little distance, into a confused mass that rendered each gun difficult to locate, whatever its surroundings might be. At 800 yards the outline of the gun is lost, while at 1,000 it harmonizes with trees, open grass land, sandy plains or broken country. As a trial the guns were placed in position on the eastern

slopes of the hills, and the artillery officers at Aldershot were invited to try and locate them from the western slope at a distance of about 3,000 yards. Although all knew the direction in which the guns were, none succeeded in finding them all, even with strong glasses. A section of the horse artillery guns were sent forward to engage them so soon as they could discern them, and they actually advanced to within 1,000 yards before they were espied. At close quarters the guns present a most incongruous appearance, being a mass of daubs of color, but the idea is a decidedly practical one, nevertheless.

The Teredo

By LINDON BATES.

(From the Yale "Scientific Monthly.")

A MENACE to every wharf from the Black Sea to Christiania, this extremely destructive mollusk, the ship worm, causes to-day enough expenditure to pay for a navy. Its steady burrowings were within an ace of causing the inundation of a large part of Holland. Along the sea wall had been built a system of dykes, made principally of timber. In three years breaks were being patched up, in five whole sections gave way. Only the heroic efforts of the whole seaside population saved the Dutch from one of the worst catastrophes in their history. The timbers were completely honeycombed, so rotten that the wood could be crushed in the hand.

The one good deed this pest has done for England was to suggest to Sir S. Brunel his plan for the Thames tunnel. This, however, will hardly balance the damage. Yarmouth must rebuild its piers every three years. Wooden vessels have to be scraped and painted every four or five months.

North America suffers as much as Europe. All down the New England coast piles are attacked and destroyed. In this region two years forms the average life of a piece of submerged timber. Channel buoys are left in the water only six months in the year, then a new set is put in and the old ones dried. Even in the brackish water of New Haven harbor, ship bottoms and wharf supports are attacked.

The zone of the ship worm's devastation is comparatively large. Wood is attacked between points well above low water mark and points ten or more feet below it. To these animals the hardest oak offers no more difficulties than the softest pine. If necessary they can bore their way through the toughest knots. Teak alone resists their attacks.

The cause of this vast amount of damage, the *Teredo Navalis*, much resembles the common worm from which comes its usual name. It is a true mollusk of the order of bivalves. Its long whitish body, tapering towards the posterior end, is found imbedded in a shell-lined burrow. Individuals of this species sometimes attain the length of ten inches, are one-quarter inch in diameter. Such size, however, is rare, four inches being about the average length.

The "head" end of the animal is covered with a helmet—a white bivalve shell like that pertaining to the clam. That this is not used in boring the hole is proved by the fact that the shell is covered by a very thin and delicate epidermis. The boring is probably done by a broad, muscular organ slightly rounded at the tip—the foot. Together with the mouth, liver and nampi, it is situated beneath the bivalve shell. The gills (feathery organs of a light brown color), and likewise the digestive organs, are in the soft part of the animal. Two pallets, shaped and fastened to the posterior end of the body, much as leaves are fas-

tened to the stem, close the teredo's hole, and protect from attacks the soft portions of the animal. Between these two plates lie the siphon tubes—used for inhaling and exhaling water. Through the lower of these (bronchial) is drawn the water breathed by the animal, and likewise those minute animalculae which serve it for food. The dorsal tube serves as the organ of excretion. Through it passes a stream of vitiated water carrying along the faeces and the wood excavated. Surrounding both the pallets and the siphon tubes is a much wrinkled muscular band, by which the teredo adheres to its "burrow."

The appearance of the teredo burrow is very peculiar. Outwardly the piece of timber infested shows a number of very small holes. Inwardly it resembles nothing more than a Swiss cheese. The channels run in all directions sometimes so close to each other that the wood separating them is as thin as paper. But between the holes there is always a partition, for the animals never interfere with each other. Their sense of hearing seems to enable them to tell when they are approaching the outside of the wood or are nearing another burrow and they turn aside. The holes are always lined with irregularly laid shell and they generally go with the grain. Like many other mollusca, the teredo passes through a long series of complicated metamorphoses before arriving at full maturity. The eggs, from the beginning of the breeding season in May, are confined in the gill cavity. Here they have their first period of growth. From the gill cavity the embryos are discharged in the form of free swimming animals covered with vibrating cilia or hairs, by which they swim. In this stage they are almost exactly like ciliated infusoria. Next they lose these locomotive filaments and develop a rudi-

mentary bivalve shell. In the third stage their relation to other bivalves is apparent in their resemblance to the common mussel. They have a mantle and shell covering their entire body and another sort of cilia replaces those lost. This bivalve character is further accentuated by the development of a long foot used for creeping and by the appearance of eyes and organs for hearing. These eyes, however, disappear as the animal elongates and the locomotive cilia are lost. In this stage the young teredo, settling on some convenient piece of wood and starting with a hole about the size of a pinhead, begins his burrow.

One season suffices to mature the ship worm. Beginning with a very small hole it grows and enlarges the orifice as it goes in. Since it is able from its sense of hearing to touch or avoid the holes of other teredos, its tunnels are often crooked, even tortuous. But when the animal is brought quite to a standstill, by not being able to advance the burrow further, it enlarges the ends of its holes. Then the openings to the outside are hermetically closed, and in its self-made grave the teredo curls up and dies.

Contrary to what is usually supposed, for food the ship worm depends, not on the timber in which it lives, but on minute animals and diatoms. The excavated wood passes unchanged through its body. The hole that forms its home seems to be made entirely for protection.

This fact has much to do with the failure of many attempts to make wood teredo-proof by poisons. Up to date creosote and dead oils are the remedies which have given the best results. The piece of lumber to be so treated is first steamed. Next the air is exhausted and the poisonous or noxious compound is forced in under a pressure of four hundred pounds to the square inch. Usu-

ally, however, this system fails of the desired result. At Christiania, timbers poisoned in this manner were found to be, three years later, quite riddled with teredo. In some instances, however, piles so treated have been known to remain free from ship worms for as many as fifteen to twenty years.

Although poisoned timbers are often used for such structures as government docks (which must be as permanent as possible), for ordinary piers and for submerged work, the expense of so treating the wood is generally greater than the cost of periodically laying new shafts, which, in this New England locality, can be driven at about \$1.50 per pile. The cost of the treated pile is so much greater than this, that with the added element of uncertainty, poisoning the wood is, for practical purposes, hardly worth while.

Since thorough drying or periodic exposure to fresh water will kill the teredo, if the woodwork is of such a kind that either of these methods is applicable, it is generally applied. Our coasting vessels keep themselves free from "worms"

by laying to in fresh water while loading and unloading. All along this coast two sets of buoys are kept, and those which have lain in the water for a year are changed for others in June or July. The alternate set is dried out and serves the next year. In this manner buoys which, if left in the water three years, would probably see the end of their service, are made to last for twenty. Of course, the most thorough defense would be one which prevented the entrance of the young animal. Copper sheathed vessels are quite free from its attacks, while copper paint, creosote or coal tar frequently applied have the same effect. Piles may be defended by broad-headed nails closely driven, for the ship worm seems to avoid entering any wood impregnated with iron rust.

That the cheapest way in which wooden piers and docks can be maintained is by rebuilding them every few years, is a remarkable commentary on the injury wrought by the teredo. Any improvement on the present clumsy and expensive methods of protection will be a very genuine benefaction.

57,750 Horse Power from One Concern

Fifty-seven thousand seven hundred and fifty horse power in electric motors are now supplied from the mains of the New York Edison Company. These motors are used for every conceivable industrial purpose, from the largest electric elevator and hoists to sewing machines and dental lathes. The use of electric power in printing establishments, machine shops and refrigeration is increasing rapidly.

Armor to Protect from High-Tension Current

An armor for insuring safety to workers with high-tension electric currents has been invented by Professor Artemieff. It is a safety dress of fine but closely-woven wire gauze, weight 3.3 pounds, and completely inclosing the wearer, including the hands, feet and head. Clad in this armor the inventor receives discharges from currents of 75,000 to 150,000 volts, and handles live wires at will without feeling any shock.

Artificial Gutta Percha

A NEW method of producing an artificial gutta percha; patented by Mr. A. Gentsch, of Germany, promises to be of great value to the electrical world, and is attracting much attention. The fundamental part of the Gentsch process is the use of oils, waxes or asphaltum, thickened by heating them to a temperature of from 100 to 200 centigrade, allowing water to drip into them and occasionally stirring the mass. As this operation is continued, the oils or other substances named begin to thicken, and eventually attain such a consistency as to render further stirring difficult. When this point has been reached the thickened masses are ready for the final operation.

The patentee relies for obtaining this thickening effect not so much upon the water as upon the calcium carbonate, magnesium carbonate and magnesia contained in it. Water specially charged with these ingredients is preferably used for the purpose. That oils can be converted into masses of any desired point of consistency by treating them with the alkaline earths or their carbonates, or with magnesia, or magnesium carbonate, has been known almost from time immemorial. Processes of this kind have been practised extensively for years in the rubber industry for the manufacture of spewed rubber tubing and like products. Gentsch claims for his modification of this these substances with the heated oils in

process that it enables him to incorporate such an immensely fine state of subdivisions as to render them far more reactive, with the result that a very much smaller amount of these substances will produce the desired thickening effect.

Gentsch uses the oils thickened by the above process, in conjunction with waxes of a high melting point (Carnauba wax), to prepare his new gutta percha, by incorporating india rubber with them under special conditions, which are set forth in his German specification No. 116,092 of 1900. In his own words the process is as follows:

“Wax of high melting point, either by itself or in admixture with the above-named thickened oils, is subjected to a kneading treatment, together with india rubber, at a gradually rising temperature, which should, however, in no case actually reach the melting point of the thickened oils or waxes used. The proportions mentioned are 50 parts of wax (thickened?) and 50 parts of india rubber, or 40 parts of wax, 10 parts of thickened oil and 50 parts of india rubber, the whole to be kneaded at a temperature rising to 200 C. as a maximum.”

The result is said to be a product in all respects resembling gutta percha—in many points even superior to it. It is believed that the new product may prove adapted to use as an insulator for deep-sea cable, for which gutta percha has heretofore had no rival.

The Circular Mil

A circular mil is a circle one one-thousandth inch in diameter. A wire one foot long and one circular mil cross section is called a mil-foot.

The Electrical Age

Incorporated April, 1902

CHARLES A. LIEB, - - - - PRESIDENT
A. G. GREENBERG, SECRETARY AND TREASURER

New York, January, 1903

Volume XXX

No. 1

Published Monthly.

Subscription, \$1.00 per year. Single Copies, 10 Cents.
(\$2.00 Per Year to Foreign Countries.)

20 BROAD ST., NEW YORK. Telephone 1628 Cortlandt.

THE ELECTRICAL AGE (Incorporated)
Entered at New York Post Office as Second Class Matter.
Copyright, 1902, by THE ELECTRICAL AGE.

TO ADVERTISERS

Changes for advertisements and new advertisements **must** be in this office by the **20th** of the month to be included in the issue in the month following. The advertising pages carry printed matter measuring five and a half by eight inches. Cuts intended for use on these pages should be made to accord with these measurements.

Correspondence and semi-technical articles, with suitable photographs for reproduction, or cuts, are invited. Accepted matter will be promptly paid for. We cannot be responsible for any unsolicited manuscripts, but when stamps are enclosed all unavailable matter will be returned. Postage must always be fully prepaid. Cuts to be available for illustrating articles must conform to the column or page measurements. The columns are 2½ inches wide. Cuts for single column use should not exceed that width. Cuts to go across the page should not be more than five inches wide, and full page cuts may not exceed 4½ x 8 inches.

As "The Electrical Age" is going to press word comes from Halifax that Marconi has at last succeeded in sending a message across the Atlantic from his station at Cape Breton, Nova Scotia, to Poldhu, Cornwall, a distance of 2,100 miles, by means of his wireless telegraph. At the same time, Mr. Marconi sent a message to the Hon. W. S. Fielding, Minister of Finance at Ottawa, announcing that he had transmitted a message to King Edward, and offering to send a message from Canada to the Home Government. The London "Times" also received the following, signed by its correspondent at Glace Bay, Nova Scotia: "Being present at its transmission in Signor Marconi's Canadian station, I have the honor to

send through the 'Times' the inventor's first wireless transatlantic message of greeting to England and Italy."

Book Reviews

The How and Why of Electricity

By Charles Tripler Child; Electrical Review Publishing Company, New York. Pp., 5 x 7 ½ inches, 127 Cloth, \$1.

In giving to this work its sub-title, "A Book of Information for Non-technical Readers," the late Charles Tripler Child gave it incidentally that which is perhaps its highest praise. A work which is so worded as to make it easily read and understood by non-technical readers and which at the same time is as correct technically as any treatise upon electrical subjects had to be which came from the pen of the late technical editor of the "Electrical Review," fills one of the greatest needs of the day. This is particularly true in the treatment of so delicate a science as electricity, where a vast amount of ignorance can easily be hidden under the guise of obstruse language, and even the technical reader finds it difficult enough to keep himself correctly informed.

Mr. Child's preface tells clearly the scheme of the book.

"It is not the purpose of this book," he says, "to tell what electricity is, for the writer does not know; but to tell something of its properties, of how it is generated, handled, controlled, measured, and set to work, and to explain how familiar electrical apparatus operates."

The subject is treated in a series of logically connected chapters, which begin with a dissertation on "The Electric

Current," and end with "X Rays," and include descriptions on batteries, electromagnets, induction and reactive coils, the telegraph, the telephone, the dynamo in its various types, motors, lamps, power transmission, storage batteries and wireless telegraphy. It is a valuable text book which should be in every man's library; but more than that, it is interesting to read.

"Prices Paid for Electric Lighting by Various Cities of the United States." This valuable pamphlet of 60 pages, which has been issued free by the Fort Wayne Electric Corporation, of Fort Wayne, Indiana, contains, it is asserted, information gathered by means of circular letters from 2,800 cities, towns and villages. This information is tabulated in alphabetical order by States and then by towns. These tables show the name of the town, its population, the number and kinds of lights used (arc, incandescent, oil, gasoline), their candle power, schedule for burning, the price per lamp, and the cost of fuel.

"The Yale Scientific Monthly" for December contains articles on "Some Advantages of Military Drill," by Capt. Samuel A. Smoke, U. S. A.; "Pneumatic Tubes for Mail Service," by A. W. Bacon, and "The Use of Balloons in War," by John B. Naething.

"The Report of the Twenty-first Annual Meeting of the American Street Railway Association," held at Detroit in October, forms a volume of 350 pages, and is a valuable record of the important papers read and of the discussions and other proceedings of the meeting. The frontispiece is a portrait

of Mr. H. H. Vreeland, the retiring president, and there are many other illustrations in the body of the book.

"The Journal of the Franklin Institute" for December contains the concluding portion of Prof. Robert H. Thurston's paper on "The 'Series-Vapor' and 'Heat-Waste' Engines as Supplementary to Single-Vapor Engines," which was begun in October. Among its other interesting features is an article by J. Merritt Matthews, Ph.D., on "The Industrial Development of Indigo," and a description of a new binocular microscope by Frederick E. Ives.

Catalogues

The De Laval Steam Turbine Company has sent out a 22-page bulletin descriptive of "direct-current turbine-dynamos" of from one and one-half to 300 horse-power capacity. These dynamos are made on purpose for being connected to and driven by the De Laval steam turbine.

The Case Automatic High-Speed Engine is described in a new catalogue recently issued by the New Britain Machine Company, of New Britain, Ct. The catalogue is profusely illustrated with cuts which make entirely clear the mechanism of this most compact engine, while on the last pages are illustrations showing some interesting examples of its use. Among the latter are two cuts, one showing Case engines operating the lighting outfit of Buffalo Bill's Wild West Show, and the other showing how they were used for like work with the Barnum & Bailey circus.



Personal



MR. GEORGE W. ALDRICH, of Rochester, N. Y., formerly Public Works Commissioner, has been appointed secretary of the New York State Board of Railroad Commissioners.

MESSRS. J. J. BELLMAN and HENRY SANFORD, 2nd, have opened offices in New York, to transact a general engineering and contracting business.

MR. CHARLES C. BENSON, formerly of the Citizens' Street Railway Company, of Newbury port, Mass., has gone to San Juan, Porto Rico, where he will act as manager of the San Juan Light & Transit Company.

C. A. COFFIN, president of the General Electric Company, has been elected a director of the United States Mortgage and Trust Company, of New York City.

MR. WILLIAM J. CLARK, general manager of the foreign department of the General Electric Company, and also one of the leading officials of the British Thompson-Houston Company, Limited, which is now controlled by the General Electric Company, is on a visit to the United States and making his headquarters at the offices of the General Electric Company in New York City.

MR. CHARLES CARLSON, night manager of the John Street exchange of the New York Telephone Company for several years, has taken a place in the company's office. The girls under his charge gave him a gold watch in recognition of his uniform courtesy and kindness.

WILLARD L. CANDEE, of the Okonite Company, has left New York to be present at the laying of the land lines of the new Pacific Cable both in San Francisco and Honolulu.

DR. GEORGE C. CALDWELL, since 1868 professor of chemistry at Cornell University, has retired, in accordance with the recent regulations of the trustees permitting professors to retire with a pension.

MR. WILLIAM FAHNSTOCK was elected to succeed Mr. William G. Starrett as a director, at the annual meeting of the Metropolitan

Street Railway Company. No other change was made in the board.

MR. J. W. DEENTLY, president of the Chicago Pneumatic Tool Company, has returned from a visit to Europe. During his absence, he has made important German contracts in the interest of his company, and has made final plans for the location of a large pneumatic tool plant in Scotland. The Scotch plant will handle the business of the company in Great Britain and the English Colonies.

MR. ESHABRAU HATA, telephone engineer of the Japanese government, is visiting telephone exchanges in the West, studying modern telephone practice. He is accompanied by Mr. C. Owoyama, a Japanese electrical engineer.

MR. J. BEYERS HOLBROOK, M. E., on December 1 became a member of the firm of Charles Henry Davis and Partners, of New York city.

DR. J. H. HYSLOP, professor of logic and ethics at Columbia University, has resigned, owing to ill health.

MR. W. F. C. HASSON has been elected chairman of the Honolulu Engineering Association.

MR. JAMES S. HEMMINGWAY has been elected president of the Fair Haven & Westville Railroad, of New Haven, Conn., to succeed Mr. Henry S. Parmelee, deceased.

MR. J. N. JACKSON has been elected president of the Augusta, Ga., Railway and Electric Company.

MR. EDWIN R. KNOWLES, of New York City, has been retained as consulting engineer by the St. Lawrence Power Company.

MR. EDWARD G. LENDER, who was for some time the chief engineer in charge of the Western Electric Company's works in New York city, has taken charge of the plant of the Prudential Insurance Company of America, at Newark, N. J.

MR. GEORGE F. McCULLOCH, president of the Union Traction Company, of Indiana, has returned from an extended trip through Europe.

Mr. McCulloch was accompanied by Mrs. McCulloch, for the benefit of whose health the trip was made.

MR. ARNIEN OSCAR KUEHMSTED, of Chicago, was married on November 26th in that city to Miss Marie Chisolm Gregg, daughter of Mr. and Mrs. Joseph Gregg, 5108 Hibbard Avenue.

MR. RUDOLPH MEIEHLING, of Reading, Pa., has been engaged by that city to make an estimate of the cost of a modern electric lighting plant large enough for the city's needs.

MR. T. C. MARTIN, of New York, has been appointed "editor of progress in the field" by President L. A. Ferguson of the National Electric Light Association. The Office is a new one, created at the recommendation of Mr. H. L. Doherty, Mr. Ferguson's predecessor as president.

MR. FREDERICK L. MERRILL, formerly of the Chicago office of the Westinghouse Electric & Manufacturing Company, has purchased an interest in the Standard Railway Materials Company, of Chicago. This company represents the R. D. Nuttall Company and the A. & J. M. Anderson Company.

MR. JOSEPH E. MONTAGUE, of Chicago, has become manager of the local lighting and power plant at Niagara Falls, N. Y.

MR. Y. NOGAMI, chief engineer of the Tokio Electric Light Company, of Japan, is here to secure data regarding new equipment. He is a guest at the Empire Hotel.

MR. S. S. NEFF has been engaged by W. E. Baker & Company, of New York, as superintendent of construction, operation and traffic in their various street railway enterprises.

MR. NORTON P. OTIS, chairman of the board of directors of the Otis Elevator Company, has been elected to Congress.

MR. J. B. PERKINS, of Toledo, Ohio, has completed plans for the power house of the Cleveland, Painesville & Ashtabula Electric Railway to be erected at Painesville, Ohio.

MR. F. A. PICKERNELL, electrical engineer for the American Telephone & Telegraph Company, in New York, is removing to Boston, where, it is understood, the "long-distance" engineering work will be concentrated.

MR. JOHN D. ROCKEFELLER, of the Standard Oil Company, is now the largest stockholder of the Manhattan Elevated Railway Company. He has, in round numbers, 100,000 shares of the stock which is 25,000 shares more than stands in the name of Mr. George Gould.

MR. EDWARD H. RICHARDS has been appointed assistant to Mr. Arthur C. Ralph,

general superintendent of the Boston & Worcester Street Railway, of Worcester, Mass.

MR. EDWIN REYNOLDS, formerly general superintendent of the Edward P. Allis Company, and chief engineer of the Allis-Chalmers Company, Milwaukee, Wis., has been made the consulting engineer of the entire concern. Mr. Irving H. Reynolds succeeds him as chief engineer of the Allis-Chalmers Company.

MR. L. W. STANTON, who has been electrical engineer and superintendent of equipment for the Federal Telephone Company, of Cleveland, Ohio, has resigned and opened offices in the same building as a consulting telephone engineer.

MR. W. STEWART has been appointed electrical superintendent of the Adams Gas Co., of Adams, Mass.

MR. JULIAN RALPH has been appointed manager of the Eastern headquarters of the Louisiana Purchase Exposition Company. His offices will be in New York.

MR. GEORGE W. RISTINE, of Chicago, has been appointed to the management of the Louisiana Purchase Exposition's Transportation Department.

MR. ARTHUR WARREN, the head of the publication department of the Westinghouse Companies, who was here for some weeks, has sailed again for England. The ramifications of the Westinghouse interests in Europe are now so large and widespread as to require Mr. Warren's constant attention there.

MR. LUTHER STIERINGER has been recommended by the Committee on Science and Arts of the Franklin Institute, Philadelphia, for the John Scott Legacy premium and medal for his "worthy contributions to the art of electric illumination." Mr. Stieringer is wintering on the Mexican border and in Southern California on account of his health.

MR. ARTHUR STANLEY has taken charge of the New York office of Robbins & Myers, of Springfield, Ohio, and will represent their well-known products, with headquarters in the Maiden Lane Building, Broadway.

MR. CHARLES A. TREMERE, formerly president of the Florida Electric Company, of Jacksonville, Fla., has sold out his interest to Mr. T. W. Dunk, of that city.

MR. CORNELIUS VANDERBILT has written an interesting article in the December *North American Review* on electricity as a motive power for trunk railroads.

MR. JACOB WENDELL, JR., of Wendell & Mac Duffie, sailed on November 25 for Europe, and will stay until the middle of January.

MR. J. W. YOUNG, secretary of the Allis-Chalmers Company, has been appointed general manager of the London offices of the Company. He will be succeeded by Mr. J. H. Seaman, the third vice-president of the company.

MR. S. W. WARE, formerly mayor of the city of Adelaide, South Australia, is in the United States for the purpose of studying American electric traction methods and elec-

trical plants, it having been decided to convert the existing horse-car system in Adelaide into an electric system. He is a guest at the Fifth Avenue Hotel, New York.

MR. N. G. WILSON, of the British Westinghouse Electric & Manufacturing Company, Limited, who has charge of the turbine engine department of the new Manchester plant of the British Company, has been visiting Pittsburg.

MR. J. H. VAN BRUNT has been appointed general manager of the St. Joseph Railway, Light, Heat & Power Company, of Joseph, Mo.

Trade Notes

THE CAMBRIDGE ELECTRIC LIGHT COMPANY, of Cambridge, Mass., has decided to displace its direct-current power distribution system by an alternating-current system. The company has purchased from the Westinghouse Electric & Mfg. Co., ninety-nine induction motors, ranging in size from one to fifteen horse power, which will take care of the bulk of its power service.

DODGE & DAY, modernizing engineers, have been commissioned by the Heating, Ventilating and Foundry Co., of Pittsburg, to equip the new plant which is being erected for that company at Wheeling, West Va.

GREAT ELECTRIC PLANT FOR DETROIT. A mammoth electric power plant for the Edison-North American combination, is to be erected on 40 acres of river front property lying between Fort Wayne and the Solvay Process Co.'s works. It will be able to supply the manufacturers of Detroit and vicinity with all the electric power they can use. It is also probable that it will furnish power for the new trolley line to be built by the Black-Mulkey syndicate, from Detroit to Monroe, and for the extension of the Detroit United, now running between Detroit and Wyandotte. At least \$6,000,000 will be spent in the erection and completion of the plant. Work will be commenced soon.

THE CLEVELAND CLIFFS IRON COMPANY is about to install an electric power distribution system for operating mixers and blowers in its plants at Gladstone, Mich., and in the Pioneer Iron Works of Marquette, Michigan, which it owns. Westinghouse apparatus will be added

and the company has also ordered a Baldwin-Westinghouse electric locomotive for shifting cars in its yards.

THE AMERICAN STEEL PACKAGE COMPANY, formerly the Lodi Steel Box Mfg. Co., has moved into the new large plant recently erected at its headquarters in Defiance, Ohio, and it announces that it is now in a position to give to patrons the most prompt service.

ROSSITER, MACGOVERN & CO., of New York, have purchased from the Metropolitan Street Railway Company the entire electrical equipments of the 146th street and Twenty-fifth street power stations. These stations were installed only a few years ago, and to-day their machinery represents the highest development of the direct-current type of engines and generators. Their further use by the Metropolitan Street Railway Company has been rendered unnecessary by the building of that company's mammoth high-voltage station and the substitution of converters for generators in the sub-station. The 146th street station was shut down last summer. The Twenty-fifth street station will soon be closed. Rossiter, MacGovern & Co., it is understood, will install a greater number of the units from these stations in some of the power houses of the Massachusetts Electric Companies, to help take care of the enormous summer traffic of that company. The firm's purchase consists of seven 850-kilowatt General Electric generators, direct connected to Cross compound engines, made by the Pennsylvania Iron Works.



Current Engineering and Scientific Notes

Abstracts from the Foreign Papers



The Bremer Arc Light

[*Zeitschrift des Oesterreichischen Ingenieur und Architekten Vereines.*]

THE Bremer lamp differs from the others in having its carbons set at an acute angle, and in the use of an electromagnet to deflect the arc. Besides these details of construction, the carbons differ from those usually employed in having about 20 per cent. of metallic salts mixed with the carbon of the electrodes. These consist of halogen compounds of silicon dioxide, calcium dioxide, potash, alumina, borax, magnesia, bromine and silicates of calcium sodium. The more infusible of these greatly increase the luminous intensity of the lamp, while the more fusible constituents protect the carbon from rapid disintegration. These lamps give about three times the light output of that of the usual direct-current lamp, and this is explained by the fact that the passage of the current between the two poles carries materials of the electrodes which the high temperature and the electrolytic action bring to a white heat. Spectrum analysis shows the lines of the metals and not the bands of the corresponding compounds. The arrangement of the carbons and the effect of the magnet give a large fan-shaped electric flame of extraordinarily high light power, and, although the arc is long, its resistance is no greater than that of the usual lamp, as these glowing oxides are good electrical conductors. The lamp consists of two carbons held in tubes inclined at an

acute angle, a reflector, an electromagnet and a small metallic igniter. The operation is as follows: The magnet has a differential winding. When the circuit is first closed no current passes through the series coil, as the carbons are neither in contact with one another nor the metallic igniter. The action of the magnet releases simple clutches, which allow the carbons to slip down in their tubes. At the same time the magnet draws upward the metallic igniter, which short-circuits the two carbons. A current at once passes, and this, flowing through the series winding of the magnet, overcomes the differential winding, drawing the clutches in and holding the carbons fast, and at the same time allowing the igniter to fall away. The arc is thus established, and the weak magnet blows it out into the characteristic fan shape. The lamp burns for about 20 minutes before it is necessary to feed. By this time the increased length of the arc has so lowered the series current that the differential coil again comes into action, and the same process is again gone through. The light of the lamp is a very good gold yellow, and it is particularly rich in orange and red rays, although the blue and violet are not lacking, as shown by the photographic effects. These rays, however, are masked by the orange and red. The economy of the lamp is shown by tests made by the author and Prof. Wedding. A nine-ampere lamp, taking 44 volts at the arc, has a mean hemispherical candle power

of 3,200 and a maximum of 4,800. The specific efficiency is 0.124 watt and the effective efficiency, allowing for 11 volts drop in the windings, is 0.155 watt per candle. Distribution curves show excellent characteristics. The lamp is not suitable for interior lighting, but is exceptionally good for outside illumination. The predominance of the red and orange rays is a valuable feature in marine lighting. A notable feature of this lamp is the ability to change the quality of the light by varying the metallic constituents, and it is noteworthy that this great advance in electric lighting has come about through the aid of the chemist.

Some Rubber Like Compounds

[*India Rubber World.*]

Almost as long as the rubber business has existed there have been certain compounds in the line of plastics that have a physical resemblance to rubber and that are used where a certain amount of resilience is required. Indeed, in one or two instances they have been sold to rubber manufacturers as new and valuable substitutes for rubber. The basis of these compounds as a rule are glue and glycerine, both of which have an affinity for water which renders them useless in many lines where they would otherwise be valuable. One of these for printers' rollers (the Jackson compound) is made of 16 pounds glue, 16 pounds glycerine, 1 pound borax, 1 pound Japan. A variation of this compound is Borchardt and Bergman's composition for the manufacture of dolls' heads, hands, and feet. This is 5 pounds of glue, 10 pounds sugar, 2 1-2 pounds glycerine, 3 pounds Perry's white. It is quite similar to the composition of Doebrich: 1 pound glue, 1-4 pound glycerine, 1-2 pound sugar, 1 tablespoonful of flour, with a little albumen and color-

ing matter. None of the above uses appeal directly to the rubber trade, yet the glue and glycerine compound is quite largely used as a covering for gas tubing. It is a curious fact that gas easily penetrates the thickest sort of rubber tube, but if that tube be covered with the glue and glycerine compound it is practically impervious. The Barr compounds for gas tubing, are 10 pounds glue, 12 pounds glycerine, 4 ounces soap, 1 ounce borax, 3-4 ounce copperas. A later and simpler compound comprises 30 pounds glue, 30 pounds glycerine, 1 1-4 ounces bichromate of potash.

Wiring Consumers' Premises

[*Electrical Engineer.*]

It will be recalled that, in its General Powers Bill of this year, the London County Council sought powers, among other things, to enable the metropolitan borough councils having their own electrical undertaking to wire consumers' premises for the electric light, and to borrow money for this purpose. Clauses to this effect were inserted in the bill at the request of a large majority of the local authorities in London, but owing to certain technical questions of procedure being raised the clauses were afterward struck out of the bill, and were not even considered in committee. That such facilities are greatly needed in London to enable the local authorities to make the best possible provision for electric lighting in their respective areas there is no doubt, and we are pleased to see that the County Council proposes to insert similar clauses in its General Powers Bill of next year to those which were dropped this session. Although objections may be raised to the principle, we should greatly like to see the borough councils empowered to supply the lamps, as well as to wire and fit up the consumers' premises. In our opinion

this is most desirable, because consumers, where they have to buy themselves, often use inferior lamps, which bring the electric lighting undertaking into discredit. The success of this second application to Parliament must, to a very large extent, depend upon the co-operation of the local authorities, and we trust they will not fail to support the County Council in this matter.

Metallic Films by Cathode Projection

[*Comptes Rendus.*]

M. L. Houllevigne describes a method for obtaining metallic films on glass or other substances. The best method is to place the plate which is to receive the film upon the anode, and mount the cathode above it in such a manner that at a slight pressure the dark cathode space just touches the plate. The current first of all clears the cathode of occluded gases. This process is particularly long in platinum, and especially in palladium. Then the substance of the cathode itself is projected and deposited partly upon the glass plate and partly upon the anode. The deposits may present all degrees of transparency and opacity, accordingly to whether the operation be continued for hours or days. Bismuth so deposited does not show any change of resistance in a magnetic field, and is, therefore, probably perfectly amorphous. Iron shows magnetic rotatory polarization, but the author has not been able to find the double refraction announced by Righi.

Radiography

[*Electricity, London.*]

The present state of radiography has been outlined by Dr. S. Henry Smith, an English expert. After making thousands of electrographs, or skiagraphs, he has discarded all other apparatus in favor of a 14-inch-spark Ruhmkorff coil, a lithanode accumulator and a home-

made Wehnelt break, using the mechanical break worked from the accumulator for soft tissues, the Wehnelt direct from the mains through a resistance for the bones and thick parts. He insists, contrary to a recent London hospital opinion, that all pictures should be true photographs, timed to show in detail the bone ulcer or other feature to be studied. It is now possible to locate all foreign bodies, to show fractures and dislocations, and to prove in some cases stone in the bladder or kidneys, but a negative result does not always prove the absence of stone. Aneurism of the heart and disease of the lungs may be shown occasionally, though not infallibly. Curative effects have been produced in several cases of stiff joints, with exposures of 30 seconds at intervals of three days, and in this promising field of usefulness there seems to be much to learn. Burns and harm to patients generally result from ignorance of the operator.

Aluminum as an Abrasive

[*Neueste Erfindungen & Erfahrungen.*]

A. Bernhard of Hamburg, Germany, has discovered a valuable property of aluminum, viz., that it is able to sharpen cutlery, the effect produced being most astonishing. Though a metal, aluminum has the structure of a fine stone; it possesses a fine dissolving power and develops during the whetting process an exceedingly fine metal setting substance greasy to the touch, which shows strong adhesion for steel. The blades obtain such a fine, razor-like edge that even the best whetstone cannot compete with the result. Thus, knives which have been carefully sharpened on a whetstone, upon a thousandfold magnification, still exhibit irregularities and rough spots in the edge, while in the case of knives whetted on aluminum, when magnified to the same extent, the edge appeared as a straight, smooth line.

Telegraphic Postage

[*The London Chronicle.*]

The idea that a letter placed in a suitable receptacle could be conveyed by electricity at a rate well-nigh comparable to that of the express trains seems to have struck an Italian experimenter, Piscicelli by name. The nearest approach to the system is that of "telepherage," but here the rate of progression is, of course, relatively slow. In the case of the Piscicelli system it is intended that the letters should be conveyed in boxes composed of aluminum along wires arranged on the overhead system analogous to that seen in the tramways of many towns. Experiments are to be made with the system between Rome and Naples, but there are so many very obvious difficulties in the way of the scheme becoming generally useful that we may await the results of these experiments before hailing the invention as a benefit to mankind at large.

Electrical Engineering in Japan

[*The Electrical Review, London.*]

Japan.—The engineers of Japan have not been slow to recognize the superiority of electricity over steam power, and according to the report of Consul Forster on the trade of Nagasaki for the year 1901, the enlightened proprietor of the Mitcu Bishi dockyard and engine works has spared no expense in obtaining tools and machinery of the latest and best patterns. During the past year a new machine shop, 200 feet in length, was erected and fitted with four cranes—one of 20 tons capacity—and 35 machines of the newest pattern, all driven by electric

power. The boiler shop has also been enlarged, and an overhead crane of 40 tons capacity installed, and in accordance with the proprietor's scheme of improvements, steam power is being gradually discarded in favor of electricity. To meet the increasing requirements of power, the station at the engine works has been enlarged and a new one erected at the ship-building yard, the latter having at present 21 motors, of an aggregate brake horse power of 367. The foundry shop has been enlarged, and a saw mill fitted with vertical saws, planing machinery, etc., erected, all the machinery in the latter having been imported from the United Kingdom. The total import of machinery into Nagasaki during the last year showed in the aggregate an increase of 15,371 English pounds over that of 1900, the preponderance of British trade being most marked in this item. Cranes and drilling machinery were imported from the United Kingdom to the amount of 12,314 English pounds and 4,052 English pounds respectively, no other country sharing in the import of those articles. Under the head of miscellaneous machinery, the share of the United Kingdom was 36,549, that of Germany and the United States being 1,030 and 2,107 English pounds respectively. In fact, the entire trade in metals and machinery is practically in the hands of British producers, and although Germany and Belgium have a small share in the metal trade, the competition of the United States, which at one time appeared to be assuming formidable proportions, has almost entirely died out.



With Our Foreign Consuls



Substitute for Coal.—Consul Gun-saulus, in a report to the State Department from Toronto, says:

Recognizing that a good and cheap substitute for anthracite coal would prove a great boon to the people of many States of the Union, and having learned that the efforts in Canada to produce dense fuel blocks from peat have within the last few months been brought to a successful issue, I have made a careful inquiry, with a view to reporting whatever has been definitely accomplished, and I feel that practical experiments, which have been perseveringly continued for some years, have now resulted in the economical production of a salable peat fuel, highly satisfactory for domestic purposes.

Manufacturing operations on a commercial scale have been reported upon by engineers of high standing, and all agree in the opinion that methods and appliances are now available whereby peat briquettes may be produced, ready for shipment, for a maximum manufacturing cost of \$1.50 per ton, and probably for considerably less in plants of large capacity.

A number of experienced business men and Government officials concur in the engineers' conclusion, and I find that the large majority of customers are much pleased with the fuel, which, if burned with proper regard to the few simple precautions necessary to insure the best results in combustion, cannot fail to meet the most exacting requirements hereto-

fore expected of anthracite coal. There is, however, some difference of opinion as to length of time a given weight of peat briquettes will burn, as compared with the same weight of anthracite. Theoretically, the heat units in peat being fewer, it may be argued it must burn out faster, but, with effective control of draughts, it is surprising how nearly its lasting quality approaches that of hard coal.

Stauber Process for Peat Fuel Making.—Frank H. Mason, Consul-General at Berlin, says:

“The unprecedented scarcity and high cost of fuel last year, and the unrelenting policy of coal-producing syndicates in restricting their output to maintain high prices since the stress of demand has subsided, have combined to stimulate experiments and investigations which have for their purpose the better utilization of peat and lignite, with which Germany is endowed. Numerous processes, more or less successful, have been perfected and tested on an industrial scale, until one invented by Engineer Stauber is announced, which has the indorsement of the Royal Chemical Testing Station, at Berlin.

“According to the published report of this institution briquettes made by the Stauber process have a heating value of 6.850 British thermal units.” (This is about one-half the heating value of the average bituminous coal in the United States). “This is fully up to the stand-

ard of brown coal, which has the defect of containing from 1.5 per cent. to 2.75 per cent. of sulphur, whereas the new turf briquettes are wholly free from that impurity, and are, therefore, adapted to a number of uses for which charcoal is now employed.

"The 'Stauber process' for working peat consists, so far as has been revealed, of a series of especially contrived machines by which the crude turf is pulverized, fibers, roots and other impurities eliminated, the water removed by compression to the proper proportion and the cleansed material reduced to uniform consistency and pressed into molds by automatic machinery. By the new process peat will to large extent replace lignite or brown coal, as a cheaper and far more abundant material, for briquettes so made will have a heating value not only for domestic heating, but for making steam and various minor processes of manufacture for which bituminous coal has hitherto been deemed indispensable. It is expected that the new process will not only serve to greatly relieve the scarcity of fuel in Germany, but eventually furnish a surplus for export into Switzerland and Italy.

"I would further state that the manufacture of briquetted peat has attained a high standard of technical perfection. There were used in Berlin in 1900, 1,011,747 tons, retailing at \$5 per ton."

Peat Development in Ontario.—Consul A. G. Seyfert, of Stratford, writes:

The whole question of making the inexhaustible beds of bog commercially valuable lies in the drying process. The genius who will invent a machine to satisfactorily extract the moisture from crude peat will not only make a fortune, but will be a public benefactor.

Thus far the nearest solution to the problem lies, probably, in the machine invented by Mr. Dobson, now in use at his peat works at Beaverton, near Lake Simcoe, in northern Ontario. This machine consists of a press, drier and spreader, and is a most ingenious contrivance, for it cuts, pulverizes and spreads the material at the same time. This reduces the moisture 50 per cent., and the balance is taken out by the drying process. The machinery in operation at this plant has a capacity of 20 tons a day. The bogs are three miles from a railroad, and yet the demand for the fuel is such that it brings \$3.25 a ton at the plant, and is retailed at Toronto at \$4.25. The plant near Stratford now has a daily capacity of 25 tons and a ready sale for all the fuel it can produce. It is run night and day, with a view to supplying the demand caused by scarcity of hard coal.

Canada annually consumes nearly 3,000,000 tons of anthracite coal, all of which comes from Pennsylvania. Most of this is delivered during the summer months. The prolonged strike has changed the situation to such an extent that this summer no coal was delivered, and a serious fuel famine confronts the people of this latitude. This condition of affairs has given a tremendous impetus to the manufacturing of peat for fuel all over the Province, and will probably lead to the perfection of inventions, so that this crude bog will, in course of time, be the leading fuel, and, to a large extent, take the place of hard coal.

Rubber and Gutta Percha Crops of Brazil.—Consul K. K. Kenneday, of Para, sends the following report:

The political troubles in the Acre territory have had a serious effect upon the rubber trade throughout that region, and will undoubtedly result in largely

reducing the crop. The rubber produced on the Beni and the Acre is considered the best that comes to Para, and its loss will therefore be felt by shippers and importers alike.

Rubber from the islands and from the Purus, Jurua, Madeira, Solimoes, Rio Negro, Javary, Japura, Jutahy, Ica, Baixo Amazonas and Branco rivers and their affluents is coming down in great quantities, and the quality rules very high.

Caoutchouc—It is said that the caoutchouc forests of Peru, from which nearly the whole supply of this product has heretofore been drawn, are practically exhausted. This is the result of the wasteful methods pursued by the gatherers who, instead of bleeding the trees, cut them down. This destructive process has been going on for many years, and now the former great caoutchouc forests of Peru are almost decimated. I am reliably informed, however, that there is an almost inexhaustible supply of caoutchouc in the little-known regions about the Upper Madeira. In the near future gatherers must look to Bolivia for their supply of this gum. It is understood that a strong effort will be made to prevent their destroying the trees, as in Peru. Experts state that the tree can be tapped in a special manner, and its gum extracted year by year for a long term before it becomes exhausted.

A serious obstacle to the successful production of rubber on the head waters of the Madeira is the system of taxation now in effect. Rubber merchants are charged 23 per cent. ad valorem export duty by the State of Matto Grosso. The State of Amazonas also charges 23 per cent. duty.

Gutta Percha—The supply of balata in sight here is so great that no fears of a shortage need be entertained for years to come, if the business is properly and

intelligently handled. Experts report that there is not a tributary to the Amazon which does not show forests of this tree upon its banks.

As one result of my previous report on this subject, three syndicates—English, Belgian and German—are now in the field to produce gutta percha. The unhappy feature of the situation is that no American syndicate has so far put in an appearance.

The importance of this new industry in Brazil may be realized when it is known that the market price of balata is equal to that of the best rubber, and the cost of production is less than one-tenth that of rubber.

The balata fields of the Guianas and Venezuela are said to be nearly exhausted, which makes the discovery of the supply on the Amazon of the utmost importance to the commercial world.

Another advantageous feature in connection with the production of balata is that it does not necessitate the risk of life attendant upon the gathering of rubber. The balata grows upon high ground, as well as on the margins of the swampy streams, where the fevers lurk. It is a common saying here that every ton of rubber from the upper river costs two lives. This can never be said of balata, for men may work at this industry with no greater risk than usually attends any labor in the tropics, and four men will gather as many kilograms of balata per day as 30 men can obtain of boracha.

Engineer Titles in Cuba.—Minister Squiers, of Habana, transmits the following:

The order (No. 81, March 18, 1902) authorizing engineers with foreign titles to exercise their profession, serve in public office and fulfill official commissions upon presentation of said titles to

the Department of Public Instruction, is repealed. The authorization granted to engineers mentioned in order No. 81, as well as those subsequently granted by the Department of Public Instruction, remain in force. According to order No. 90 (June 23, 1899), and modifications on December 5, 1900, engineers having titles issued by foreign universities shall be admitted on their incorporation in the University of Habana, provided their titles fulfill the requirements. The incorporation of titles shall be effected in the form established for the school of sciences, the examinations being upon matters studied in the school of engineers. Cubans holding titles as engineers issued prior to this law by foreign schools of recognized fame and reputation may, on presentation of said titles to the Department of Public Instruction, exercise their profession without examination. Agricultural engineers from the School of Agriculture in Habana, in order to exercise their profession freely in Cuba, shall present their certificate of degree to the Department of Public Instruction, and, upon proof of its authenticity and personal identification, they shall receive a title authorizing them to exercise their profession in Cuba. Professional men holding foreign titles, who have not previously revalidated them, shall not exercise their professions nor discharge any professional duty—national, provincial or municipal—dating from the promulgation of this law (October 28, 1902). The engineers above referred to are alone excepted.

Alcohol from Acetylene.—The following has been received from Consul Haynes, of Rouen:

The producers of alcohol in France are somewhat disturbed because of the

new invention by which alcohol is manufactured by synthesis by means of acetylene. Although the process is as yet too costly to endanger their industry, the members of the Society of Agriculture of the North, in a recent meeting, issued the following recommendation:

Considering the facts that alcohol manufactured from fruit and agricultural distilleries can be replaced by mineral fabrication by means of carburet; that these carburets can be produced economically only in foreign countries possessing powerful waterfalls and special minerals; that this manufacture will ruin the distillation of roots, grains and fruits, to the exclusive profit of foreign countries, the Society of Agriculture of the Nord recommends that a tariff of 50 francs (\$9.65) per 100 kilograms (220.46 pounds) be placed on the carburets from foreign countries which are to be used for the manufacture of acetylene.

Demand for Traction Engines in Johannesburg.—Consular Agent W. D. Gordon writes from Johannesburg:

I believe that the call for traction engines in this country will be a considerable one, and our manufacturers interested in this line should make an effort to secure the business. The country has been practically stripped of draft animals, and it will be many years before the requirements in this line will equal the demand. If manufacturers will forward this office catalogues, price lists, weights, discounts, etc., I will endeavor to place them in the hands of interested parties. An inquiry has just been received for a corn clever and corn mill, to be operated by a traction engine. Several of these can be sold.



Digest

Engineering Literature of the Month



Improvements Suggested for Explosive Motor Engines

A PAPER read by Capt. C. C. Longridge before the British Institute of Mechanical Engineers discussing the oil motor cars of 1902, criticising them and suggesting improvements, has aroused a great deal of comment among persons interested in motor car construction. It contains many suggestions and ideas that differ from present ordinary practice which are well worth investigating.

The gasoline motor of the present, Captain Longridge declares, is imperfect and must be improved. The type of motor which he thinks most suitable for automobiles and which he declares will ultimately be generally adopted is the two-cycle, in spite of the fact that the motor in almost universal use is the four-cycle. Such a general change is unlikely, as both cycles have inherent advantages peculiar to themselves and the character of the work has much to do with a proper choice.

The use of heavy oil, he says, must be provided for in the motor of the future, and greater economy must be attained by higher compression. This would be a decided advance. The practice of casting cylinders in one piece with their water jackets is not considered advisable, the use of light aluminum water jackets being preferable, and the substitution of steel tube cylinders, ground into cast heads, as a means of producing stronger,

lighter and more powerful engines strongly advocated.

For governing the speed of the engine Captain Longridge makes a somewhat novel suggestion when he declares in favor of throttling the exhaust, retaining in the cylinder a portion of the products of combustion to dilute the new charge and lessen its power. He says that the presence of the residual gases does not prevent ignition unless they exceed 58 per cent. of the mixture. This system would have an advantage over charge throttling in that the compression in the cylinder remains constant.

There are many other points in Captain Longridge's paper which will prove most interesting and instructive to those interested in automobile construction.—*Automobile Review.*

Amount of Supplies Used by a Locomotive

A railroad man with a penchant for figures has just completed some statistics on the Northwestern's Chicago special, which are not at all dull. He finds that on the daily 1,046 mile journey of this train from Chicago via Omaha, the six engines which pull it consume 81,576 pounds of coal, more than forty tons, 57,250 gallons of water—quite enough to supply the wants of a good sized community. To prevent hot boxes on the cars as a result of fast running, 167 pounds of cotton waste and 704 pints of lubricating oil are necessary every day

in the year. This means that in the twelve months more than thirty-two tons of waste, and over 25,600 gallons of oil are used.

The figures given are taken from careful observations on the run of the special from Denver to Chicago, and are approximately correct for the Chicago-Denver run. Engines making an ordinary speed of 50 or 60 to 70 miles per hour are every day occurrences.

The railroader with the pencil figures that this train expends an energy while running at its usual speed equal to 500 horse power, and at its highest bursts of speed as much as 1,000 horse power. If this enormous energy in the flight of the train across the country could be harnessed, it would furnish more than enough power to run all the trolley cars in Omaha.—*Black Diamond*.

Gas Arc Lamps

A number of years ago Denayrouze endeavored to obtain a higher flame temperature inside the mantle by blowing the required amount of air into the burner, and Bandsept later tried to draw in more air by an injector construction of burner. It was realized that the maximum temperature could not be obtained inside the mantle unless there was enough air thoroughly mixed with the gas to obtain complete combustion. The ordinary Bunsen burner did not and does not now draw in enough air for complete combustion, and this makes it necessary to employ special devices when high efficiency is desired. The Bandsept construction has not been adopted in this country, but the Kern burner, which is a development along the same line, is now in satisfactory use among our gas consumers, and depends upon superior design and construction for its high efficiency, chimneys being dispensed with in the domestic installations. These

burners seem to have gone as far as design alone in the injector and mixer construction can go. The Denayrouze idea of adding air under pressure possesses the disadvantage of requiring auxiliary apparatus which must also be maintained, thus limiting the field of application very much, although the English tests of the Suggs and Keith apparatus do not by any means point to failure.

In Germany there was another idea conceived, and the product put on the market during 1899 and 1900, which obtained the desired result by connecting the small globe surrounding the mantle to a tall chimney above it, which produced sufficient draft to suck the consumed gases rapidly through the mantle and so much reduced the pressure inside it as to create an increased upward draft of air through the Bunsen tube. The quantity of gas passing through the jet depended upon its size and the gas pressure, and was very little influenced by the increased suction in the Bunsen tube, so that the desired increase in the proportion of air was obtained, a high degree of temperature produced, and the resulting incandescence far exceeded that of ordinary burners. This was further increased by permitting the gas to become heated before entering the burner.

This design is known as the Lucas lamp, and to the inventor is due the credit of providing the gas industry with a means of displacing electric arc lamps, for our popular gas arcs are the outgrowth of the Lucas principle. It seems strange that there should be so great a demand for gas arcs, while England is still struggling with gas or air under pressure, and Germany with cheap burners and cylindrical chimneys (with the exception of a block of Lucas street lamps in Berlin and some in Leipzig,

Elberfeld, Koenigsberg, Charlottenburg, Gottingen and Chemnitz). We have this year taken to gas arcs to a truly remarkable extent, and manufacturers are kept busy with orders.—*Progressive Age*.

Rolled Steel Wheels

Rolled steel wheels for steam and electric car service are now successfully manufactured because of the advances made in recent years in the art of steel casting.

The present wheel is an evolution of the old Fowler wheel. The cast steel blank is still used. The advance in the art of steel casting within the last few years now makes it possible to secure a solid and reliable production. The cast steel blanks from which the car wheels are rolled are of the same shape as the finished rolled wheels as far as the hub and plate of the wheel are concerned. The rim of the cast steel blank, however, is thicker than the finished rim of the car wheel, as is also the flange. In the manufacture of these wheels from the cast steel blanks, the blanks are heated in an oil furnace to a temperature which will soften them enough for rolling. They are then put in a rolling machine, in which the rim is compressed by three rolls, two of which press under the rim and one on the top and sides. A wheel makes about eighty revolutions in the process of rolling the rim, and the metal of the rim is reduced in cross section from 15 per cent. to 20 per cent., which goes to show the remarkable amount of compression of the metal produced by the rolls. The plate and hub of the wheel remains untouched and unaltered in cross section. The compression secured by the rolling invented by Mr. Fowler is even more complete than is secured in the making of open tires. It is claimed that since the tire is one piece with the rest of the wheel, that the

wheels can be safely worn down much thinner than any tire mechanically held on a center. One feature of the rolling process which cannot escape an intelligent observer is the great amount of power taken in the rolling of a rim, even though the amount of reduction in cross section of the casting by one revolution be extremely small, all of which shows that a great amount of compression of the metal is taking place. But the fact that the cross section of the rim is reduced so much demonstrates this even more forcibly. The amount of rolling necessary to compress the metal of the rim is judged by the amount of rolling the rim will stand without forming a fin between the rolls. Just before this fin begins to form the rolling is stopped, and the wheels are taken out and delivered to a closed pit, where they cool gradually and evenly for several days.—*Street Railway Journal*.

New Stanley-Kelly Alternating Current System

A system of alternating-current generation and distribution that is said to be of peculiar value in connection with systems of high tension long distance transmission, in which the power factor varies greatly with the load, has been invented by William Stanley of Great Barrington and John F. Kelly, of Pittsfield, Mass. The invention has for its object the production and distribution of alternating currents in such a manner that the pressure is automatically regulated without regard to the nature of the load upon the mains. This is considered a great advance, since in the present transformer system in which a constant potential generator is used for supplying transformers in multiple arc with lamps in multiple on their secondaries it is necessary that the transformers should not only be made to be used with the poten-

tial upon the mains, but they must be adapted to the generator so as to have an insignificant leakage or magnetizing current at no load.

"It is well known," say the inventors in their patent specifications, "that any closed magnetic circuit transformer which will not burn up on account of core loss when connected to constant potential mains will be adapted to the generator so as to have such insignificant leakage current, and that if the primary and secondary coils are sandwiched or intermingled so that the turns are all in the same homogeneous magnetic atmosphere approximate constancy of potential at the secondary terminals within limits is inherent and that the limit at which the drop in secondary potential exceeds any given amount, or, in other words, the capacity of the transformer depends only upon the resistances of the primary and secondary coils, so that if the cross section of the wire is increased the capacity will be increased and the approximation to constancy of potential at the secondary terminals for any given load will also be increased. In open magnetic circuit transformers or other similar phase-displacing devices, however, there is always a large magnetizing current which lags behind its electromotive force, disturbing the ordinary generator and reducing its output by demagnetizing its field magnet. These transformers, therefore, although they may be made to withstand the potential of the mains, are not adapted to the ordinary alternating current generator and cannot be satisfactorily used in the system at present in use.

"The purpose of our invention is to generate and distribute alternating cur-

rents so that when the currents supplied lag or lead because of the nature of the load such lagging or leading currents instead of disturbing the generator shall automatically act to maintain constant the potential on the mains. The advantages of such generation and distribution will be manifest to those who are familiar with the act as now practiced, since it does away with disturbing effects of translating devices, such as motors and open circuit transformers, which are very troublesome in ordinary systems.

"The principle upon which our improvement depends is that of the inductive action of one alternating current upon another, the two being related as primary and secondary—viz., that if the two circuits be properly disposed, if the secondary current lags positively it will react upon the primary circuit increasing the primary current to the extent necessary to maintain the magnetic flux, and if the secondary has a negative lag then it will react upon the primary circuit, reducing the primary current to the amount necessary to maintain the flux.

"In carrying out our invention the lagging or leading currents are the armature currents, which are made to act upon field-energizing circuits carrying alternating currents. The resistance of the field energizing coils is made very low, so that the electromotive forces applied to the terminals of the energizing coils and the counter electromotive forces set up therein will always be substantially equal and the variation of current in the energizing circuits will be controlled practically only by the reaction of the armature currents."—*Western Electrician*.

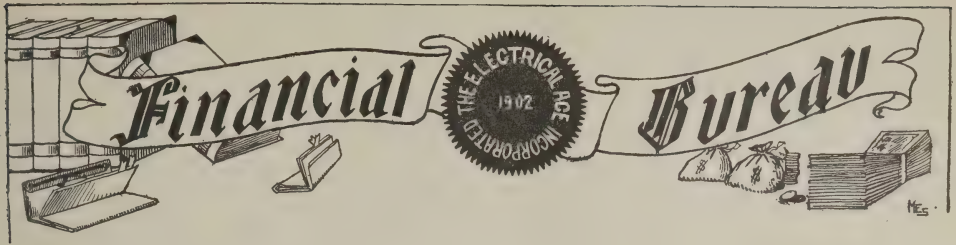

Street railway companies, electric lighting companies and gas companies which desire their reports to appear in the Financial Bureau of THE ELECTRICAL AGE are requested to forward the information so that it may reach us by the 20th of each month. Monthly reports are requested showing gross receipts and when possible operating expenses. Companies are also requested to furnish the highest and lowest prices for which their stock has sold in the market for the previous month.

Street Railway and Other Statements

Companies.	Date.	Gross Earnings.		Net Earnings.	
		1902.	1901.	1902.	1901.
ANNAPOLIS, WASH. & BALT.....	Oct.	\$8,424	\$7,787	\$4,122	\$3,077
July 1 to Oct. 31.....		31,623	31,471	13,078	13,458
AUBURN INTERURBAN.....	Sept. qtr.	31,169	28,191	13,106	6,725
BALT. & ANNAPOLIS SHORT L....	Oct.	9,157	9,005	2,985	3,068
July 1 to Oct. 31.....		39,990	37,695	13,155	13,663
BINGHAMTON RAILWAY.....	Oct.	17,107	16,884	6,414	9,591
BROOKLYN RAPID TRANSIT.....	Oct.	1,114,772	1,067,132	469,796	363,520
July 1 to Oct. 31.....		4,702,510	4,478,232	2,175,761	1,742,376
CHARLESTON CON. RY, GAS & E..	Oct	40,739	39,038	13,494	14,476
Dec. 1 to Oct. 31.....		621,444	457,980	268,132	168,514
CHICAGO & MILWAUKEE ELEC...Nov.		14,112	12,040	7,723	6,236
Jan. 1 to Nov. 30.....		177,249	159,451	104,497	91,217
CIN., DAYTON & TOL. TRAC.....Nov.		39,967	19,247
June 1 to Nov. 30.....		266,216	131,642
CIN., NEWPORT & COVINGTON..Oct.		97,677	70,630	47,173	32,108
Jan. 1 to Oct. 31.....		904,256	681,272	400,954	278,470
CLEVELAND, ELYRIA & WEST...Nov.		27,924	21,125	11,180	8,756
Jan. 1 to Nov. 30.....		273,101	232,885	120,929	104,467
CLEVELAND, PLAINESVILLE & E.'Oct.		16,213	15,639	6,558	7,081
Jan. 1 to Oct. 31.....		160,677	139,823	74,058	68,024
CROSSTOWN ST. RY., BUFFALO.					
July 1 to Sept. 30		112,917	194,766	51,461	72,489
DETROIT & PORT HURON S. L. Nov.		32,117	27,979	10,930	10,533
July 1 to Nov. 30.....		204,644	184,935	87,280	85,585

Companies.	Date.	Gross Earnings.		Net Earnings.	
		1902.	1901.	1902.	1901.
DETROIT UNITED	Nov.	\$290,750	\$254,807	\$123,256	\$106,125
Jan. 1 to Nov. 30.....		3,171,833	2,767,730	1,380,515	1,236,681
DETROIT UNITED RY.....	Nov.	290,750	254,807	123,256	106,125
Jan. 1 to Nov. 30.....		3,171,835	2,767,730	1,380,517	1,236,682
All properties.....		3,623,151	1,563,418
DETROIT & P. HURON SHORE L..	Oct.	34,869	31,008	13,600	12,261
July 1 to Oct. 31.....		172,527	156,955	76,351	75,052
Nov		32,117	27,979	10,930	10,533
July to Nov. 30.....		204,644	184,935	87,280	85,585
DULUTH, SO. SHORE & AT.....	Oct.	259,205	231,159	98,800	69,107
July 1 to Oct. 31.....		1,031,483	971,746	426,616	382,063
DULUTH SUPERIOR TRACTION..	Oct.	46,587	38,325	20,333	15,802
Jan. 1 to Oct. 31.....		442,191	373,342	209,210	169,268
Nov		46,416	39,217	19,990	17,018
Jan. 1 to Nov. 30.....		488,607	412,559	228,200	186,286
ELGIN, AURORA & SOUTHERN..	Nov.	33,543	27,322	12,469	10,184
June 1 to Nov. 30.....		222,850	196,431	96,988	94,269
Jan. 1 to Nov. 30.....		375,432	231,465	154,194	144,039
GALVESTON CITY RAILWAY.....	Oct.	16,815	10,804	6,266	2,602
Jan. 1 to Oct. 31.....		144,515	162,882	45,391	30,612
GAS & ELECTRIC CO. OF BERGEN COUNTY, N. J.....	Oct.	31,375	24,400	15,067	10,145
June 1 to Oct. 31.....		129,643	116,480	57,405	52,689
HARRISBURG TRACTION.....	Oct.	37,447	32,163	15,092	9,592
Jan. 1 to Oct. 31.....		382,573	325,145	166,527	128,818
HOUSTON ELECTRIC CO.....	Sept.	32,282	27,537	14,478	12,707
INDIANAPOLIS & EAST. RY.....	Oct.	10,108	7,421	4,614
Jan. 1 to Oct. 31.....		82,530	69,243	36,981
INTERURBAN ST. RY. (N. Y.) July 1 to Sept. 30		3,662,480	3,596,545	1,978,855	2,033,285
JACKSONVILLE ELECTRIC CO...	Sept.	16,575	5,628
May 1 to Sept 30.....		85,900	27,938
JAMESTOWN ST. RY.....	Sept. qtr.	56,685	42,526	31,554	21,702
LACLEDE GAS LIGHT CO.....	Nov.	117,110	104,362
Jan. 1 to Nov. 30.....		1,021,237	934,319
LAKE SHORE ELECTRIC RY.....	Oct.	41,976	32,641	12,292	10,421
Jan. 1 to Oct. 1.....		373,850	301,598	129,139	104,144

Companies.	Date.	Gross Earnings.		Net Earnings.	
		1902.	1901.	1902.	1901.
LEHIGH TRACTION.....Nov.		\$7,583	\$10,419	def. \$1,333	\$5,970
Jan. 1 to Nov. 30.....		88,719	118,228	29,909	64,224
LONDON ST. RY., ONT.....Oct.		11,646	10,165	4,237	3,749
Jan. 1 to Oct. 31.....		127,306	116,812	49,086	44,539
Nov.		12,355	12,084	5,147	6,082
Jan. 1 to Nov. 30.....		139,661	128,897	54,233	50,621
LOS ANGELES RY.....Sept.		126,532	52,775
Jan. 1 to Sept. 30.....		1,051,630	793,580	466,525	314,648
LOWELL ELECTRIC LIGHT CO..Sept.		17,281	13,832	5,719	3,421
July 1 to Sept. 30.....		48,745	40,138	15,943	9,196
MEXICAN TELEPHONE.....Oct.		21,179	18,047	10,493	9,274
Eight months.....		161,116	140,707	73,624	63,399
MILWAUKEE GASLIGHT CO....Nov.		71,695	63,970
Jan. 1 to Nov. 30.....		605,838	501,931
MILWAU. ELEC. RY. & LT. CO. ..Nov.		237,390	205,471	131,512	103,185
Jan. 1 to Nov. 30.....		2,477,131	2,188,069	1,309,843	1,108,195
MILWAU. LT., HT. & TR. CO.Nov.		29,374	25,301	12,874	8,464
MINNEAPOLIS GEN. ELEC.....Sept.		41,625	35,998	18,760	20,280
MONTREAL STREET RY.....Oct.		181,406	166,061	84,987	80,850
NEW LONDON STREET RY.....Oct.		4,406	4,355	def. 187	607
July 1 to Oct. 31.....		34,948	35,113	14,656	17,651
Nov.		3,904	3,865	587	342
July 1 to Nov. 30.....		38,852	38,978	15,243	17,993
NORTHERN OHIO TRACTION...Nov.		63,362	49,247	28,690	21,501
Jan. to Nov. 30.....		680,888	563,525	305,746	243,650
OAKLAND TRANS. CONS.....Oct.		81,935	74,960	36,611	27,114
Jan. 1 to Oct. 31.....		777,672	317,517
ORANGE COUNTY TRACTION....Sept.		10,069	10,615	5,062	4,546
July 1 to Sept. 30.....		37,212	37,453	20,936	20,618
PACIFIC ELECTRIC RY. b.....Aug.		71,718	31,324
PEEKSKILL LIGHT & R. R.....Oct.		9,023	3,317
July 1 to Oct 31.....		37,696	16,110
PLATTSBURG TRACTION....Sept. qtr.		9,912	9,929	3,575	4,930
ROCHESTER RY.....Nov.		91,179	85,925	47,306	40,962
Jan. 1 to Nov. 30.....		1,004,583	924,007	480,573	384,641

Companies.	Date.	Gross Earnings.		Net Earnings.	
		1902.	1901.	1902.	1901.
SACRAMENTO ELEC., GAS & RY.	Oct. Feb. 1 to Oct. 31.....	\$46,707 363,100	\$36,901 312,104	\$21,284 186,775	\$18,975 165,212
SAVANNAH ELECTRIC CO.....	Sept.	42,882	38,402	20,080	16,538
SEATTLE ELECTRIC CO.....	Sept.	163,685	127,425	55,796	43,795
SPRINGFIELD (ILL.) CON.....	Oct.	21,627	19,927	8,728	6,723
SYRACUSE RAPID TRANSIT.....	Oct. July 1 to Oct. 31.....	59,585 242,326	56,205 223,001	26,941 108,458	25,380 100,651
SYRACUSE & SUBURBAN..	Sept. 30 qtr.	22,294	22,273	9,800	9,333
TERRE HAUTE ELECTRIC CO....	Sept.	32,716	32,156	12,773	9,377
TOLEDO RAILWAY & LIGHT....	Nov. Jan. 1 to Nov. 30.....	125,936 1,319,483	113,077 1,184,705	70,119 656,594	55,804 611,930
TOLEDO, B. GREEN & SO. TRAC..	Oct. Jan. 1 to Oct 31.....	21,325 202,175	14,709 146,411	9,046 94,034	6,056 58,939
TWIN CITY RAPID TRANSIT.....	Oct. Jan. 1 to Oct. 31.....	304,317 2,971,411	270,953 2,611,118	164,091 1,639,865	152,898 1,424,217
UNITED TRACTION (ALBANY)...	Nov. Jan. 1 to Nov. 31.....	128,451 1,372,245	46,110 411,725
VIRGINIA PASS. & POWER CO....	Oct. July 1 to Oct. 31.....	129,342	74,358 314,192
YOUNGST'N-SHARON RY. & LT.	Oct. Jan. 1 to Oct. 31.....	41,434 354,006	17,534 156,675

Stated Reports of Companies

Interurban Street Railway.

Balance Sheet as of Sept. 30, 1902.

Assets.		Liabilities.	
Cost of road and equipment.....	\$509,039	Capital stock, common.....	\$5,880,000
Stocks and bonds of other co's...	5,100,000	Funded debt, 3 p. cent. deb. notes.	1,500,000
Open accounts.....	2,751,532	Rentals due and accrued.....	1,414,080
Supplies on hand.....	96,805	Open accounts.....	620,549
Cash on hand.....	1,219,550	Due companies and individuals...	8,038,124
Contract acct. with Met. St. Ry.		Due for supplies.....	129,358
Co. under contract.....	8,000,000	Profit and loss (surplus).....	94,815
Total.....	\$17,676,926	Total.....	\$17,676,926

Massachusetts Electric Companies.

Annual Report.

Balance Sheet as of September 30, 1902, compared.

Assets—	1902.	1901.
Sundry stocks in treasury.....	\$27,850,820	\$28,544,979
Stocks deposited to secure notes.....	2,711,000	2,711,000
Cash	25,367	231,876
Notes and accounts receivable.....	4,081,670	916,522
Discount on sale of preferred shares.....	166,250
Cash deposited to pay dividend.....	3,201	5,908
Total.....	\$34,838,310	\$32,410,286
Liabilities—	1902.	1901.
Preferred stock.....	\$17,432,400	\$15,057,400
Common stock.....	14,293,100	14,293,100
Coupon Notes.....	2,700,000	2,700,000
Accounts payable.....	750	861
Accrued dividends on preferred shares.....	174,324	150,574
Accrued interest on notes.....	30,375	30,375
Dividends uncalled for.....	3,201	5,908
Profit and loss surplus.....	204,160	172,067
Total.....	\$34,838,310	\$32,410,286

Consolidated Income Account Compared.

	1902.	1901.	Changes.
Gross	\$6,090,168	\$5,778,133	Inc. \$312,035
Expenses	3,827,372	3,015,485	Dec. 88,113
Net.....	\$2,262,796	\$1,862,647	Inc. \$400,149
Charges	1,391,239	937,206	Inc. 454,033
Balance.....	\$871,557	\$925,441	Dec. \$53,884
Dividends	676,390	779,462	Dec. 103,072
Surplus for year.....	\$195,167	\$145,979	Inc. \$49,188

In the 1902 year taxes are included in charges, whereas in 1901 they were included in expenses.

President Gordon Abbot says: "The year finished has been one of the most unfavorable in many years to the operation of street railways in New England, owing to a winter of considerable severity, an unusually cold and wet summer and the coal strikes, which caused serious interruption to the supply of fuel and heavy additional expense over the normal cost of this supply. By new construction the mileage of the companies has been increased by 41, and now amounts to 860 in 22 cities and 66 towns. There was expended the sum of \$3,083,289, of which \$1,671,521 was for construction or betterments of track and buildings, and \$1,411,767 for equipment and power. To meet this expenditure and to provide funds for certain

further necessary improvements, your trustees asked and obtained in May last the authority of the shareholders for an issue of 55,000 new preferred shares; 23,750 of the shares were delivered and paid for prior to September 30th last. It has been estimated that it would require an expenditure of \$10,000,000 to place the 800 odd miles of road in the Massachusetts electric system in a position to be economically operated and show proper returns upon the invested capital. This plan is being systematically carried out, and it is estimated that it will require at least two years more before the period of extraordinary expenditures upon the properties is brought to a close. Hence any figures of operation at the present time as a basis of the properties' earning abilities are misleading."

Edison Electric Illuminating Company, Boston.

Annual Report.

The operations for the last two fiscal years include, for the sake of comparison, the Boston Electric Light Company and the Suburban Light and Power Company, as well as the Edison Electric Illuminating Company.

Year ending June 30—	1902.	1901.
Gross earnings.....	\$2,460,158	\$2,367,359
Expenses	1,510,427	1,449,629
Net income from operation.....	\$949,731	\$917,730
Miscellaneous profits.....	25,981	13,948
Net earnings.....	\$975,712	\$931,678
Interest	132,269	105,130
Dividends	727,345	774,155
	\$859,614	\$879,285
Undivided profits.....	\$116,098	\$52,393

Balance Sheet as of June 30, 1902.

Assets—	Liabilities—
Installation and property.....	Capital stock.....
Unfinished installation.....	First mortgage bonds (B. E. L. Co.).....
Liverpool Wharf estate.....	Consols (B. E. L. Co.).....
Cash in banks.....	Premium on stock.....
Cash at office.....	Accounts payable.....
Stock on hand.....	Notes payable.....
Notes receivable.....	Accrued interest and taxes.....
Accounts receivable.....	Dividends (payable Aug 1, 1902)..
Sundry open accounts.....	Reserve for maintenance.....
	Profit and loss.....
Total.....	Total.....
\$11,392,974	\$7,850,400
558,653	293,000
225,912	957,000
163,414	1,660,388
2,500	142,790
361,161	1,105,000
1,460	69,217
245,319	196,260
37,613	654,000
	60,951
\$12,989,006	\$12,989,006

President Charles L. Edgar says in substance:

During the year the purchase of the Boston Electric Light Company was completed, and the capital stock of this company was increased 27,907 shares, to exchange for the 30,000 shares of the Boston company. The affairs of the Boston company came under the management of this company early in October of last year. All the property and assets of the Suburban Light and Power Company also were purchased for cash and its affairs turned over to this company in September of last year.

In view of the growth of the company's business, which during the past year has been at a very rapid rate, the stockholders, on May 14, 1902, authorized a petition to the Board of Gas and Electric Light Commissioners for authority to issue 16,500 shares

of new stock. This petition was granted, and authority was given to issue that amount of stock at \$200 per share. Since the close of the fiscal year the stockholders have, in accordance with this permission, authorized the issue of 7,851 new shares, and the remaining amount will be issued at some later date.

The lamps and motors connected to the company's circuits, compared with the previous four years, is shown in the following table:

June 30—	Incandescent Lamps.	Arc Lamps.	Motors. (H. P.)
1898.....	161,464	1,486	6,473
1899.....	183,165	1,791	7,504
1900.....	211,471	2,131	9,428
1901.....	247,935	2,503	10,651
1902.....	442,034	8,548	19,130

Connecticut Railway & Lighting Company.

Annual Report.

Gross income from railway, \$1,113,778; electric service, \$297,136; gas, \$204,470; total gross income, \$1,615,384. Operating expenses for railway, \$616,723; electric service, \$188,938; and gas, \$130,639. Total expenses, \$936,301; net earnings, \$679,083; taxes

and miscellaneous interest, \$107,180; net applicable to bond interest, \$571,903; interest on funded debt, \$426,556; balance, \$145,347; less extraordinary expenses incurred in betterments to lines, cars and plants, \$57,534; surplus, \$87,813.

Condensed Balance Sheet.

Assets.	Liabilities.
Construction and equipment.....\$24,523,339	Capital stock.....\$15,000,000
Cash on hand..... 41,130	Funded debt..... 9,350,000
Materials and supplies..... 128,234	Bills payable..... 260,000
Accounts receivable..... 111,541	Accounts payable..... 79,494
Accounts paid in advance..... 21,845	Advance sales and deposits..... 4,220
	Accident insurance fund..... 51,359
	Undivided profits in 1901..... 11,194
	Profits in 1902..... 87,814
	Total profits..... 99,008
	Less adjustment..... 17,992
	Profit and loss surplus..... 81,015
<hr/>	<hr/>
Total.....\$24,826,089	Total.....\$24,826,089

Secretary and Treasurer Lewis Lillie says: "The railway department shows a very healthy growth. There was an increase of 8.5 per cent. in the receipts from that department over the corresponding period of the year previous. The results of the year in the electric light department show an in-

crease in sales of 10.6 per cent. The gas department also shows an increase in sales of 16 per cent."

The company is operated under the management of the United Gas Improvement Co. of Philadelphia.

Buffalo Gas Company.

Annual Report.

Balance Sheet, Sept. 30, 1902.

Assets.	Liabilities.
Plant and equip. acct. for year...\$14,525,667	Common stock..... \$7,000,000
Bonds of People's Co., includ. rev. 80,888	Preferred stock..... 1,710,000
Stamps, etc..... 6,865	Bonds 5,900,000
Extension plant..... 19,009	Bench repair fund..... 18,302
Materials and supplies..... 54,498	Indebtedness 147,847
Treasury bonds..... 95,000	Profit and loss, surplus..... 118,744
Prepaid accounts..... 1,960	
Gas bills receivable..... 36,006	
City of Buffalo accts. receivable.. 18,052	
Resid'l and other accts. receivable. 30,816	
Bills receivable..... 8,312	
Construction account..... 17,818	
<hr/>	<hr/>
Total.....\$14,894,894	Total.....\$14,894,894

The statement of quick assets and floating debt on Oct. 1, 1902, shows quick assets of \$168,654; bills payable, nil; accounts, taxes and wages already charged to operating expenses, \$79,538; showing a net surplus of \$89,116.

The net profits for the year were \$339,167, from which interest at 5 per cent. on \$5,805,000 was paid, amounting to \$290,250, leaving a surplus of \$48,887. The preceding fiscal year showed a surplus, after paying bond interest, of \$13,689, and the year next preced-

ing showed a deficit of \$1,856. The sales of gas were increased 2.61 per cent., which compares with an increase of 8.75 per cent. in the preceding year, which was the year including the Pan-American Exposition. This increase over the Exposition year is regarded as a very favorable showing. During the year \$21,924 was expended for extension of plant, including mains, services and improve-

ments at works. The plant and equipment account in the balance sheet was increased \$80,888 and the preferred stock was increased from \$1,630,000 to \$1,710,000. These items cover the exchange of 80 one-thousand dollar bonds and 45 shares of stock of the People's Gas Light & Coke Co. for \$80,000 par of the preferred capital stock of the Buffalo Gas Co.

Western Union Telegraph Company.

Statement (partly estimated) for Quarter Ending Dec. 31.

	1902.	1901.	Changes.
Net revenue.....	\$2,100,000	\$1,858,318	Inc. \$241,682
Bond interest.....	252,550	244,000	Inc. 8,550
Balance.....	\$1,847,450	\$1,614,318	Inc. \$233,132
Dividend	1,217,010	1,217,010
Surplus.....	\$630,440	\$397,308	Inc. \$233,132
Previous surplus.....	11,528,617	9,812,557	Inc. 1,716,060
Total Surplus.....	\$12,159,057	\$10,209,865	Inc. \$1,949,192

Approximate Figures From July 1 to Dec. 31.

Net revenue.....	\$4,347,174	\$3,807,634	Inc. \$539,540
Bond interest.....	505,100	483,040	Inc. 22,060
Balance.....	\$3,842,074	\$3,324,594	Inc. \$517,480
Dividends	2,434,020	2,434,014	Inc. 6
Surplus.....	\$1,408,054	\$890,580	Inc. \$517,474
Previous surplus.....	10,751,003	9,319,286	Inc. 1,431,717
Total surplus.....	\$12,159,057	\$10,209,866	Inc. \$1,949,191

Boston Suburban Electric Companies.

Annual Report.

	1902.	1901.	Changes.
Gross	\$502,224	\$456,760	Inc. \$45,464
Expenses	388,330	365,989	Inc. 22,341
Net.....	\$113,914	\$90,771	Inc. \$23,143
Charges	81,739	77,543	Inc. 4,196
Balance.....	\$32,175	\$13,228	Inc. \$18,947
Dividends	59,902	55,496	Inc. 4,406
Deficit.....	\$27,727	\$42,268	Dec. \$14,541

The stock will not be listed upon the Boston Stock Exchange until the combination of roads is a complete proposition and able

to show what it can do in the way of earnings and dividends.

Boston Elevated Railway.

Annual Report.

Balance Sheet as of September 30, 1902, Compared.

Assets—	1902.	1901.
Cost of railways.....	\$6,047,089	\$5,278,371
Cost of land.....	4,679,548	3,514,928
Cash	2,112,974	636,799
Bills receivable.....	963,409	469,313
Current assets.....	212,010	212,010
Deposited with State.....	500,000	500,000
Materials and supplies.....	748,451	604,191
Somerville Railroad.....	102,851	102,851
W. E. property account.....	2,609,866	4,026,045
Subway	158,268	133,061
Total.....	\$18,134,470	\$15,486,573
Liabilities—	1902.	1901.
Capital stock.....	\$12,383,310	\$10,000,000
Vouchers and accounts.....	332,904	421,056
Salaries and wages.....	125,615	133,649
Dividends not called for.....	9,481	9,884
Matured coupons.....	39,550	35,400
Rent due.....	317,975	317,975
Outstanding tickets.....	21,041	20,281
Notes payable.....	500,000	375,000
Accrued liabilities.....	2,362,843	2,386,556
Sinking and specie funds.....	1,558,015	1,323,262
Surplus	483,733	462,509
Total.....	\$18,134,470	\$15,486,573

Financial Notes

Buffalo Gas earnings for November were \$35,740, an increase of 10.42 per cent.

California Gas & Electric Co. has voted to issue \$10,000,000 in 20 year 5 per cent. bonds.

Electric Company of America officials say that earnings for the year will exceed those of 1901 by 25 per cent.

Home Telephone Co., Kansas City, has sold \$1,700,000 bonds through the German Trust Company of St. Louis.

Western Union's statement for the last quarter indicates an earning capacity for the year of a fraction below 8 per cent.

American Telegraph & Telephone Co. declared last month a regular quarterly divi-

dend of 1 1-2 per cent. and an extra of 3-4 per cent.

Independent Union Telephone Co. voted last month to increase its capital stock from \$200,000 to \$1,000,000 for improvements in western New York.

Stone & Webster, of Boston, owners of the Tacoma & Seattle Street Railway, announce that they will spend \$2,000,000 in extensions in Pierce County during the next two years.

Chicago Edison Co. shareholders will be entitled to subscribe till February 2 to \$2,276,901 new stock at par to the extent of 30 per cent. of their holdings, payments to be made in four equal installments, extending to November 2.

Union Traction Company, Philadelphia, has declared a semi-annual dividend of 1 1-2 per cent., equal to 75 cents per share, payable January 1. This is the first dividend declared under the lease to the Philadelphia Rapid Transit Company.

Detroit United Railway's subsidiary company, the Windsor, Sandwich & Amherstburg Electric Railway, will execute a \$600,000 mortgage to secure an issue of 5 per cent. bonds, to be applied to cost of completing the system from Sandwich to Amherstburg.

An attachment for \$1,000,000 in the suit of John F. Plummer against the International Power Company to recover that amount for promotion services, was obtained by Dos Passos Bros. last month and sustained by decision of Judge Leventritt on motion to vacate.

Interborough Rapid Transit Co., New York, will vote on the Manhattan Elevated Railway lease proposition January 15, 1903. The remaining six installments of 10 per cent. each on the part paid stock are payable January 5, February 2, March 2, April 1, May 1 and June 1.

Manila's Municipal Board will receive bids until March 4 for a street railway franchise covering 35 miles. A deposit of \$75,000 must be made by each bidder with either the Guaranty Trust Co. or the International Banking Corporation, New York, the Philippine insular depositories in the United States.

American capitalists are interested with French financiers to merge the gas companies in Paris. The plan is to form two corporations, one under the laws of France to operate the gas plants, and another under the laws of New York or New Jersey, as a holding or securities company, the latter to be capitalized at \$50,000,000.

Consolidation of the three principal municipal corporations of Philadelphia is talked of in the near future, says the correspondent of the "Wall Street Journal." He has reasons to think that negotiations have already been going on between directors of the Rapid Transit, the Philadelphia Electric and the United Gas Improvement Companies.

Chicago Edison Co., to meet cost of general improvements, will issue \$2,276,901 new stock at once to shareholders at par. This will leave \$133,429 in the treasury. Subscriptions are due February 2 to stockholders of record January 24. Payments will be made in four installments, on February 2, May 1, August 1 and November 1. This raises the total capital of the company to \$9,866,000.

Indianapolis Traction & Terminal Co. will lease the Indianapolis Street Railway Company's lines for 30 years, issuing \$5,000,000 stock and \$5,000,000 bonds. The terms are 6 per cent. on the stock after July, 1906, and a sliding scale until then, beginning at 1 per cent. for 1 year, 3 per cent. for the next, 4 per cent. for the next, and 5 per cent. for the fourth year. Lessee will deposit \$1,500,000 stock as security. It has already arranged to place \$3,000,000 of the 5 per cent. bonds in Philadelphia.

Canadian Niagara Power Co. has just let a contract for three turbines, each of 10,000 horse power, the largest in the world. The company is sinking a wheel pit in Victoria Free Park, only a short distance back from the brink of the Horseshoe. This pit will be 170 feet deep and 480 feet long and 21 feet wide. From the wheel pit to the lower river a tunnel 2,200 feet long has been driven through solid rock. This tunnel is 25 feet high and 18 feet wide, 4 feet higher than the tunnel on the American side.

Auburn & Syracuse Electric Railroad Co., now operating the entire local street railway system in Auburn, has completed its financial plan for the operation of an interurban line between Auburn and Syracuse. The bonds issued by the company have been approved by the State Railroad Commission and purchased by N. W. Harris & Co., New York. The road between the terminals is nearly completed and ready for operation and is one of the most thoroughly modern and finely equipped electric roads in the State.

British Westinghouse Co., of which the Westinghouse Electric & Manufacturing Co. owns control, has grown with such marvelous strides that it has been found necessary to increase the capital by issuing \$1,000,000 of new 6 per cent. preference shares, the capital now being \$5,000,000 of 6 per cent. preference shares and \$3,750,000 ordinary shares. The Pittsburg company owns all of the ordinary shares. The par of the shares is \$25, one-half of the subscription to be paid at once and the remainder in the spring. Orders received since August 1 exceed \$4,125,000, against a total of \$4,660,000 for the year ending July 31. Lieutenant Colonel Montagu Cradock has been made a director to succeed Lemuel Bannister.

Manufacturers' Light & Heat Company, Pittsburgh, have authorized the issuing of \$833,000 of the new increase of \$5,000,000 of stock recently voted upon. The stock will be issued at par \$50, one share of new for each share of old stock of record December 10. The subscriptions, one-third January 24 and one-third February 20, will complete payments begun December 20 last. Part of the increase will be used to obliterate a small floating debt and for im-

provements. It is said that contracts are already being offered that will amount to \$500,000 of business for the year, and it is said that upon the completion of projected improvements the increased earnings will pay back the increased capital expenditure within a year.

Manhattan Elevated Railway's shareholders will vote January 16 on a proposal to lease the property to the Interborough Rapid Transit (Subway) Company from April 1, 1903, for 999 years, the terms being a 6 per cent. guaranteed dividend until January 1, 1906, and an additional 1 per cent. if earned; after that 7 per cent. per annum guaranteed. The shareholders will also vote on a proposition to increase the capital stock from \$48,000,000 to \$60,000,000, \$7,200,000 of such increase to be issuable as soon as authorized and the remainder not prior to January 1, 1906, the object being to provide additional funds to complete improvements now under way. The quarterly dividend payable January 2, will be at the rate of 6 per cent., contrasting with 4 per cent., the rate since April, 1897.

Rochester, N. Y., reports on good authority that control of the Central Light & Power Co., the only corporation holding an electric light and power franchise in Rochester, beside the Rochester Gas & Electric Co., will probably soon pass into the hands of a syndicate of millionaire electric light and gas men, who will develop the plant and will compete with the older company in supplying electricity to Rochester consumers. The negotiations have been in progress for a number of weeks. The purchasing syndicate is, it is said, composed of stockholders and directors of large gas and electric companies in New York and Boston. Liberal capital will be supplied for the development of the company's plant, and it is expected that in time the company will compete with the older concerns for the city lighting contract.

The copper output was lower during November, according to the figures of John Stanton. His decrease of 955 tons was 3,569 tons above November, 1901, and 2,021 above that month in 1900. Exports for the month show a falling off of 3,438 tons from October, but a gain of 2,710 over November, 1901. Foreign production of copper increased 1,208 tons over October, 2,069 tons over last year, and 3,163 over two years ago. Total exports from the United States by months have been as follows, in tons:

	1902-1	1901-0	1900-99
November	9,077	6,367	9,508
October	12,515	8,016	12,682
September	13,183	6,419	10,425
August	12,429	6,840	13,861
July	11,733	6,824	11,630
June	14,027	6,842	16,586
May	16,283	10,062	13,997
April	16,424	4,849	12,746
March	20,097	6,818	20,148

	1902-1	1901-0	1900-99
February	16,108	8,453	12,749
January	15,021	10,003	14,035
December	10,171	11,223	15,550

Metropolitan Surface Lines will all be operated by electricity before 1904, according to Presidents Vreeland and Maher of the Metropolitan and Union Companies. The Metropolitan will build 30 miles of new tracks against 23 miles last year. The Union principal lines have been entirely equipped with 9 inch Trilby rails, replacing the old 6 inch girder rails. The Metropolitan intends to equip electrically all its lines before the end of 1903. The First avenue line will be the last to be considered. On the Thirty-fourth street line the storage battery system is to be given up in favor of the underground trolley. Work on the Fourteenth street line will be begun in the spring, including an extension to Grand street and elsewhere. The Grand street line from the Desbrosses street ferry is to be built. All the construction work is to be done by the company itself. The Union Railway will lay 12 miles of track this year against 42 laid last year. There is not a single horse car line in the Bronx. President Maher says that not a single franchise owned by the company will remain another year unexercised.

Annapolis, Washington & Baltimore's \$358,000 stock has been sold to the Washington, Baltimore & Annapolis Electric for \$367,400. The stock of the Baltimore & Annapolis Short Line is not included in the sale. The negotiations have been going on for some months. The Annapolis, Baltimore & Washington Railroad runs from Annapolis Junction on the Baltimore & Ohio tracks to Annapolis, a distance of 20½ miles, and it crosses the line being built by the electric railway company from Baltimore to Washington at Odenton, 14 miles from Annapolis. Work is being pushed on the construction of the electric railway line from Baltimore to Washington, and the line may be completed in about two months. The Baltimore terminus will be at Westport, and it is expected to make a trackage arrangement with the United Railways & Electric Co. to come into the centre of the city. Washington will be entered over the tracks of the Washington Railway & Electric Co. The new line being built will be 31 miles long. The purpose of purchasing the Annapolis, Washington & Baltimore road is to convert it from a steam to an electric line and thus save building a new road from Odenton to Annapolis. The electric railway company has a franchise to enter Annapolis. Capitalists of Cleveland control the company. Work on the construction of the new \$300,000 power house of the Washington, Baltimore & Annapolis Electric Railway in East Hyattsville was begun last month, and will be prosecuted vigorously. The plant will be running by October 1 next.



Incorporations and Franchises



ALABAMA.

GADSDEN—Water-works.—City has granted franchise to R. A. Mitchell and associates for the construction of a system of water-works.

ARIZONA.

DOUGLASS—Traction Co.—Articles of incorporation have been filed for the Douglas Street Railway Company. W. H. Brophy, L. C. Shattuck, S. W. French, M. J. Cunningham and S. W. Clawson, of Bisbee; S. F. Maguire, of Douglas, are among those interested.

ARKANSAS.

MENA—Telephone System.—Kiser Telephone Company, capital stock \$50,000, to build and operate telephone lines in the counties of Miller, Little River, Sevier, Howard and Polk. A. J. Kizer, president.

CALIFORNIA.

SAN FRANCISCO—Telephone Co.—The Direct Line General Telephone Company has been incorporated. Directors: J. Finch, A. G. Andriano, W. T. Hess, J. Fay and C. E. Wiggin. Capital stock, \$2,500,000; subscribed, \$100,000.

Light and Power Co.—The Richmond Light and Power Company, has been incorporated with W. A. Bissell, of Alameda, and Walter P. Treat, N. T. Messer, Jr., Edwin Schwab and W. C. Webb, of San Francisco, as directors, has a capital stock of \$150,000.

Electric Railroad Co.—The San Francisco, Oakland & San Jose Railway Company, organized a year ago, has just filed its articles of incorporation. The company is to build an electric railway, 93 miles long, from San Francisco via Oakland and Haywards to San Jose, and branches from San Jose to Saratoga, Los Gatos and Santa Clara.

SAN BERNARDINO—Power Co.—The San Bernardino Power Company has received a franchise for the construction of an electric railway from San Bernardino to Highland.

COLORADO.

PUEBLO—Power Co.—The Pueblo and Suburban Traction Company has been incorporated with a capital stock of \$3,500,000. It will bring power over copper wires from Beaver Creek Falls to Pueblo, a distance of 50 miles. The power will be used for running street cars and for lighting.

CONNECTICUT.

BRISTOL—Traction Extension.—The Railroad Commissioners have approved the plan for the extension of the lines of the Bristol & Terryville Tramway Company from Bristol through Terryville, a distance of about 5 miles.

FLORIDA.

BROOKSVILLE—Electric Light Plant.—The Standard Pole & Tie Company has received franchises for an electric lighting and telephone system.

GEORGIA.

SWAINSBORO—Water Works.—Jesse Thompson will establish a water works system.

ATLANTA—The Gold Belt Suburban & Electric Railway Company, recently organized, has a franchise for the construction of an electric railway through White County. F. M. Scott, of Atlanta, is interested in the company.

INDIANA.

WABASH—Traction.—H. M. Lau and others, of Detroit, have secured a franchise for an interurban railway from Wabash to Marion. G. A. H. Shidler is also asking for a franchise between the two cities. The Union Traction Company is said to be behind Shidler.

TERRE HAUTE—Traction.—The County Commissioners have given a franchise to the Terre Haute Electric Company for a line on the Lafayette Road from the north city limits to the boundary line of Park County. No remuneration was asked for the grant.

INDIANAPOLIS—Traction Co.—The Fort Wayne, Bluffton & Richmond Traction Com-

pany has been incorporated with a capital of \$50,000, to build from Fort Wayne to Richmond. The incorporators are: Edward Manner, of Versailles, Ohio; Frank X. Schaffer, of Dayton; Charles Durst, of Dayton; Charles F. Manning, of Dayton, and William F. Dinnen, of Fort Wayne.

EVANSVILLE—Traction Co.—The Evansville, Boonville & Rockport Railroad Company has been incorporated, with a capital stock of \$30,000, to build an electric railway from Evansville through Vanderburg County to Newburg and Boonville, in Warrick County, and to Rockport, in Spencer County. The directors are: William Threkeld, Charles E. Maley, Claude Maley, Daniel Wertz and Edwin C. Henning.

SPRINGFIELD—Light and Water Company.—Citizens' Light and Water Company. \$70,000. Incorporators: A. R. Manley, P. G. Manley and J. M. Mitchell.

CHICAGO—Junction Railroad.—The Chicago Junction Railroad Company has been incorporated, with a capital stock of \$50,000, to extend the South Side Elevated Railroad to the stock yards and along the Lake Shore Boulevard route to a connection with the Illinois Central. These extensions will be leased and operated by the South Side Elevated Company. The incorporators are: Frederick R. Babcock, William Raymond, James Miles, John D. Black and Edward W. Everett.

IOWA.

MOUNT AYR—Traction Co.—Articles of incorporation of the Des Moines, Mount Ayr & Southern Electric Railway Company were filed with the Secretary of State on Nov. 17. Capital, \$10,000. The object is to construct a line from Mount Ayr to Creston, 25 miles. F. L. Shelton, president.

KENTUCKY.

BROWNSBORO—Traction Co.—The Brownsboro Railway Company. Capital \$25,000, has been chartered. J. Morton Morris, of Louisville, and others are incorporators.

LAWRENCEBURG—Municipal Works.—The people have voted to issue \$20,000 in bonds to erect an electric light plant and waterworks.

HARRODSBURG—Municipal Works.—City has voted issuing \$18,000 in bonds for construction of an electric light plant present one being worn out; also \$48,000 in bonds to buy and extend the local waterworks. Address "The Mayor."

LOUISIANA.

NEW ORLEANS—Trolley Service.—A company has been organized to exploit a patent of Thomas J. Burke, which it is said will enable two standard sized trolley cars running at full speed, to pass each other with but a single trolley wire. Capital stock \$100,000. Patrick J. O'Keefe is president. Among those who are backing the company is John D. Crimmins, of New York.

MAINE.

WESTBROOK—Telephone Co.—The Westbrook Telephone Company has received a telephone franchise.

MASSACHUSETTS.

HAVERTHILL—The aldermen have granted to the Haverhill & Southern New Hampshire Street Railway a location from Winter street through Locust and Granite streets to the Boston & Maine depot. The company will build a new stone arched bridge on Locust street over Little River.

GREENFIELD—Traction Co.—The Greenfield, Deerfield & Northampton Street Railway Company has been chartered. Among the directors are: J. B. Bridges, W. W. Sanderson, W. H. Belden and Oscar Belden. The company is capitalized for \$20,000.

MICHIGAN.

HOLLY—Electric Light and Power.—The Holly Electric Light and Power Company has been incorporated with a capital stock of \$10,000.

MINNESOTA.

JORDAN—Electric Light and Heating Co.—The Jordan Electric Light and Heating Company, has been incorporated, and work has already commenced. The officers are: C. H. Casey, president; H. S. Shreiner, vice-president; G. F. Schmitt, secretary; H. F. Juergens, treasurer.

MISSISSIPPI.

HATTIESBURG—Light and Power Co.—Hattiesburg Light and Power Company. Incorporators: M. Hemphill, R. H. Hemphill, H. A. Hemphill.

Electric Light and Power—The Hattiesburg, Electric Light & Power Company, Hattiesburg, Miss. Capital stock, \$30,000. Incorporators: M., R. H. and H. A. Hemphill.

NEW MEXICO.

SANTA FE—Light and Power Co.—The Capital Light and Power Company has re-

ceived a franchise from the city council to furnish electric lights, power and construct electric railroads for a term of 25 years.

MISSOURI.

LINNEUS—Municipal Electric Light Plant.—City will establish an electric light plant. Address "The Mayor."

ST. LOUIS—Municipal Lighting.—The board of public improvements has approved plans for two municipal lighting plants and advertised for bids.

NEBRASKA.

FAIRBURY—Light and Water Co.—The Fairbury Light & Water Company has been incorporated for the maintenance and operation of an electric light plant, water-works and heating plant.

HASTINGS—Telephone Co.—The Adams County Telephone Company, capital \$30,000, has been incorporated. Incorporators: J. H. Lyman, A. L. Clarke, W. H. Ferguson and others.

NEW JERSEY.

TRENTON—Railroad and Traction.—Articles of incorporation have been filed in Trenton for the establishment of the Cuba Securities Company. The incorporators are: Louis B. Dailey, Paul Tissen and F. S. Seward, who are identified with the Cuba company. The capitalization of the Cuba company is \$80,000,000. It is understood that the new company will become affiliated with the Cuba company and build and operate railroads and electric railways in Cuba.

YARDVILLE—Light, Heat and Power Co.—The Yardville Electric Light, Heat & Power Company. Capital stock, \$125,000. Incorporators: Aug. Wilf, Chambersburg, Pa.; C. A. Bulb and Charles A. Camp, both of Yardville.

NEW YORK.

NEW YORK—Electric Lamps.—The Cooper-Hewitt Electric Company, of New York City, has been incorporated, with a capital of \$2,000,000, to manufacture electric lamps in which vapor forms a portion of the conducting circuit, or in which the current is induced in a vapor. Directors: Charles B. Hill, John F. Symes, George H. Stockbridge, Charles H. O'Connor and Leavitt J. Hunt, of New York City.

UTICA—Electric Co.—The Crescent Electric Company. Capital stock, \$30,000. Directors: W. P. Campbell and J. C. Eickemeyer, Utica, and A. J. Potter, New Hartford.

SALAMANCA—Traction Co.—The Berney Traction Company has been incorporated to build an electric railway $4\frac{1}{2}$ miles long in Cattaraugus County. Capital, \$50,000. Directors: S. A. Holbrook, A. J. Edgett, of Bradford, Pa.; W. K. Harrison.

ALTAMONT—Lighting Co.—The Altamont Illuminating Company has been incorporated to supply gas and electricity in Gilderland, Knox and Altamont. Capital, \$5,000.

NORTH CAROLINA.

WASHINGTON—Electric Plant.—Stephen C. Brogan has obtained a franchise for the establishment of an electric plant to supply light, heat and power.

Ice Plant.—Incorporated: Crystal Ice Company, with a capital stock of \$100,000, by W. A. Blount, W. Swindell, William Bragaw, H. B. Mayo and C. B. Sterling.

OHIO.

CINCINNATI—Traction Co.—The Terminal Traction Company has been incorporated with a capital of \$100,000, to build a central station in Cincinnati for the electric lines from different parts of Ohio and to provide suitable terminals.

TRUMBULL—Traction Franchise.—The county commissioners of Trumbull have granted a 50-year franchise to the Middlefield-Sharon Electric Railway Company, to construct a line via Bloomfield, Green, Gustavus, Farndale and Five Points.

MEDINA—Light, Heat and Power Co.—The Medina Electric Lighting, Power & Heating Company has been incorporated with \$50,000 capital stock by M. J. Van Sweringen, O. P. Van Sweringen, J. G. Boyd, S. C. Stewart and A. J. Watt.

TOLEDO—Light, Heat and Power Co.—The East Toledo Heating & Lighting Company has been incorporated, with \$10,000 capital stock, by P. McRory, S. H. Mills, S. W. Cook, L. E. Flory and W. H. Tucker. They will furnish power, light, heat and hot water.

CLEVELAND—Traction Co.—The Western Reserve Traction Company has been incorporated, with \$10,000 capital stock, by T. A. Willard, M. A. Lander, E. Jay Pinney, C. W. Noble and E. H. Gebert. It proposes to build a line from Cleveland to Warren.

COLUMBUS—Traction Co.—The Columbiana Electric Railway Company has been incorporated, with \$10,000 capital stock, to build a

line from Salem to East Liverpool. Incorporators: D. H. Pigg, Elmer H. Miller, Henry R. Young, Daniel J. Ryan and E. C. Herat.

COSHOCTON—Traction.—The franchise of the Newark, Zanesville & Coshocton Traction Company has been extended one year by the County Commissioners of Coshocton County.

EAST LIVERPOOL—Traction Co.—The Columbian Central Electric Railway Company, with \$10,000 capital, has been incorporated by David H. Pigg, Newark; Elmer I. Miller, Daniel J. Ryan, of Columbus; Harry R. Young, C. Hecox, of Cleveland. The company proposes to build an electric railway connecting East Liverpool and Salem, passing through Lisbon.

SANDUSKY—Traction Co.—The Sandusky & Southwestern Railway Company, with headquarters at Wapakoneta, Ohio, has been incorporated by F. O. Olsen, S. W. McFarland, S. P. Douglass, Wm. H. Wyke and Ithamer E. Yarnell. The capital stock is \$1,000,000 and the company proposes to build from Sandusky to Wapakoneta through Erie, Sandusky, Seneca, Wyandot, Hardin, Logan, Allen and Auglaize counties.

OKLAHOMA.

GUTHRIE—Telephone Co.—The Topeka and El Reno Telephone Company, of El Reno, has amended its charter for twenty years, with \$100,000 capital. Incorporators: W. F. Evans, of Topeka, Kan.; F. H. Wright and C. O. Blake, of El Reno, Henry B. Johnston, of Chickasha, I. T.; and William M. Grimes, of Guthrie.

Traction Co.—The Oklahoma Traction Company has been incorporated to build either an electric or steam railroad 75 miles long, connecting Guthrie, Oklahoma City and Fort Reno. The directors are John W. Shartel, Selwyn Douglass and L. M. Spitter, of Oklahoma City, and George S. Green and U. C. Guss, of Guthrie.

Light and Traction Co.—The Guthrie Light & Traction Company has been incorporated to build a street railway by John W. Shartel of Oklahoma City and F. H. Greer, C. M. Barnes, W. H. Merten and H. H. Hagan, all of Guthrie.

EL RENO—Telephone System.—The Topeka & El Reno Telephone Company, with \$100,000 capital, by W. F. Evans, of Topeka, Kan.

PENNSYLVANIA.

WEST GROVE—Traction Co.—The West Chester Street Railway Company has received a right of way through this town from the bor-

ough council. This company is building a belt line around Chester County, covering sixty-four miles and taking in Kennett, Anndale, West Grove, Oxford, Parkesburg, Coatesville, Downington and West Chester.

ALTOONA—Electric Light Co.—The Citizens' Electric Light Company. \$1,000. Directors: Daniel G. Owens, John M. Hamer, Tyrone; Charles W. Hooner, Bellwood.

Light, Heat and Power.—The Shady Side Electric Company, to furnish light, heat and power generated by electricity. Incorporators: J. Eaton, W. Scott, N. Holmes and others.

Traction.—The board created by the last Legislature, composed of the Governor, Attorney General and Secretary of the Commonwealth, has approved the application for charters filed by the Second Avenue and Bloomfield Elevated Street Railroad Companies. The Second Avenue Company will build a line 4 8-10 miles long. It is capitalized at \$240,000. The Bloomfield Company is capitalized at \$80,000, and will build a line 1 6-10 miles long. The incorporators of the companies are the same. Charters have been issued by the State Department to both companies.

Tunnel Companies.—Charters have been granted at the State Department to the Rapid Transit Tunnel Company, capital \$1,200, and the Southern Tunnel Company, capital \$1,200, both of Pittsburg. The incorporators of the companies are: E. G. Husler, of Carnegie, president; J. W. Nesbit, J. T. Fox, T. B. Lee, M. E. Dumlery and Frank Thornburg.

NORRISTOWN—Traction.—The charter of the Souderton, Skippack & Fairview Electric Railway Company has been recorded. Its route extends from Souderton to Trooper, and the capital stock is \$100,000. E. S. Moser, of Callyville, is president. The length of the road will be sixteen miles.

WASHINGTON—Traction.—A charter has been granted to the Greene County Rapid Transit Street Railway Company, with a capital of \$50,000. The directors are: T. J. Wisecarver, Judge R. L. Crawford, T. S. Crago, L. W. Sayers and W. D. Cotterrel. They propose building lines from West Waynesburg to Morrisville.

WILLIAMSPORT—Telephone and Telegraph.—The Interstate Development Company, of this city, has been incorporated with a capital stock of \$200,000. Its purpose is to acquire telephone and telegraph lines.

YORK—Electric Water Powers.—Charters for the Long Island Water and Power Company

and for the Shenk's Ferry Water and Power Company have been recorded. The directors of both are: Albert L. Register, Ardmore, Pa.; John DeW. Duncan, Philadelphia, and George M. Bunting, Chester, Pa.

RHODE ISLAND.

NEWPORT—Traction.—The city council has passed the ordinance granting a franchise to the Newport & Bristol Ferry Railroad Company. The franchise must be officially accepted in thirty days, and the road must be completed before May 1, 1904.

SOUTH DAKOTA.

LEAD—Gas Plant.—The city has granted a franchise to the Practical Gas Company for the installation of a plant and a system of mains.

HURON—Electric Light Co.—The Gladys Electric Light, Water and Power Company, of this city, with a capital stock of \$100,000, was granted a permit to do business in Texas.

TENNESSEE.

COLUMBIA—Traction.—The Interurban Railway Ordinance has been passed by the city council, with a proviso that the work of construction shall be completed within two years.

PHILIPPI—Light and Water Plants.—Stewart Bowman, James E. Hall, S. A. Moore and others have incorporated Philippi Water & Light Company, with capital stock of \$40,000.

KINGFISHER—Ice Company.—Kingfisher Ice Company, with \$50,000 capital, by Albert Beumelli, of St. Louis, Mo.; Henry Braun, of Guthrie, O. T.; A. J. Seay, of Milo, O. T.; Bert and J. C. Robb, of Kingfisher.

TEXAS.

BEAUMONT—Electric Light and Power Plant.—Gladys Electric Light, Water & Power Co., organized under the laws of South Dakota, with a capital stock of \$100,000, has received a permit to do business in Texas.

FORT WORTH—Traction.—The Northern Texas Traction Company has received the right to extend its lines in several directions under an ordinance of the city council.

CLARKSBURG—Ice Plants.—Consumers' Ice Company and Citizens' Ice Company have consolidated as the Clarksburg Ice & Storage Company and incorporated with a capital stock of \$100,000.

ABILENE—Telephone System.—Northwestern Telephone Company, capitalized at \$75,000.

DALLAS—Traction Company.—The Metropolitan Street railway Company has been incorporated with a capital stock of \$4,500,000. The board of directors comprises A. K. Bonta, John Frost, C. H. Bryne and H. C. Koke, all of Dallas, and Guy E. Trippe, of Boston, Mass. It is stated that the company, in addition to absorbing the local electric railway lines, proposes to construct important interurban lines between Dallas and adjacent towns.

CORSICANA—Traction Co.—The Corsicana Transit Company, capital \$100,000, has been chartered to construct a street railway in the city and suburbs. The incorporators are: F. N. Stormont, Aaron Ferguson and others.

UTAH.

SALT LAKE—The county commissioners have granted to the Consolidated Railway & Power Company a franchise to extend its lines from Murray, a suburb of Salt Lake, to Sandy, a distance of about 15 miles, and from State street to the Highland Boy smelter and the smelter of the United States & Bingham Gold & Copper Company. An extension of one year's time has been allowed for extending the line on East Temple street to Twelfth South Street. Permission has also been granted for the extension of the company's Calder's Park line to Fourteenth South Street.

VIRGINIA.

BRISTOL—Municipal Water-works.—City will expend about \$25,000 to improve its water supply. Address "The Mayor."

WASHINGTON.

SEATTLE—Light and Heat.—The city council has granted permission to the Arcade Electric Company to furnish light and heat to certain portions of the city. All wires are to be underground and are to be installed at the expense of the company.

WEST SEATTLE—Electric Light and Power.—The West Electric Company has been incorporated with a capital stock of \$1,000,000 by R. W. Bender, D. N. Spear and F. E. Sander to furnish this city with power and electric light.

WEST VIRGINIA.

MARLINTON—Light and Water Plants.—Chartered: Pocahontas Water, Light & Power Company, capital stock \$25,000, by E. M. Arbogast, W. A. Bratton, F. R. Hunter and J. W. Price, of Marlinton, and George C. Martin, of Lowelton, Pa.

LIBRARY
OF THE
UNIVERSITY of ILLINOIS

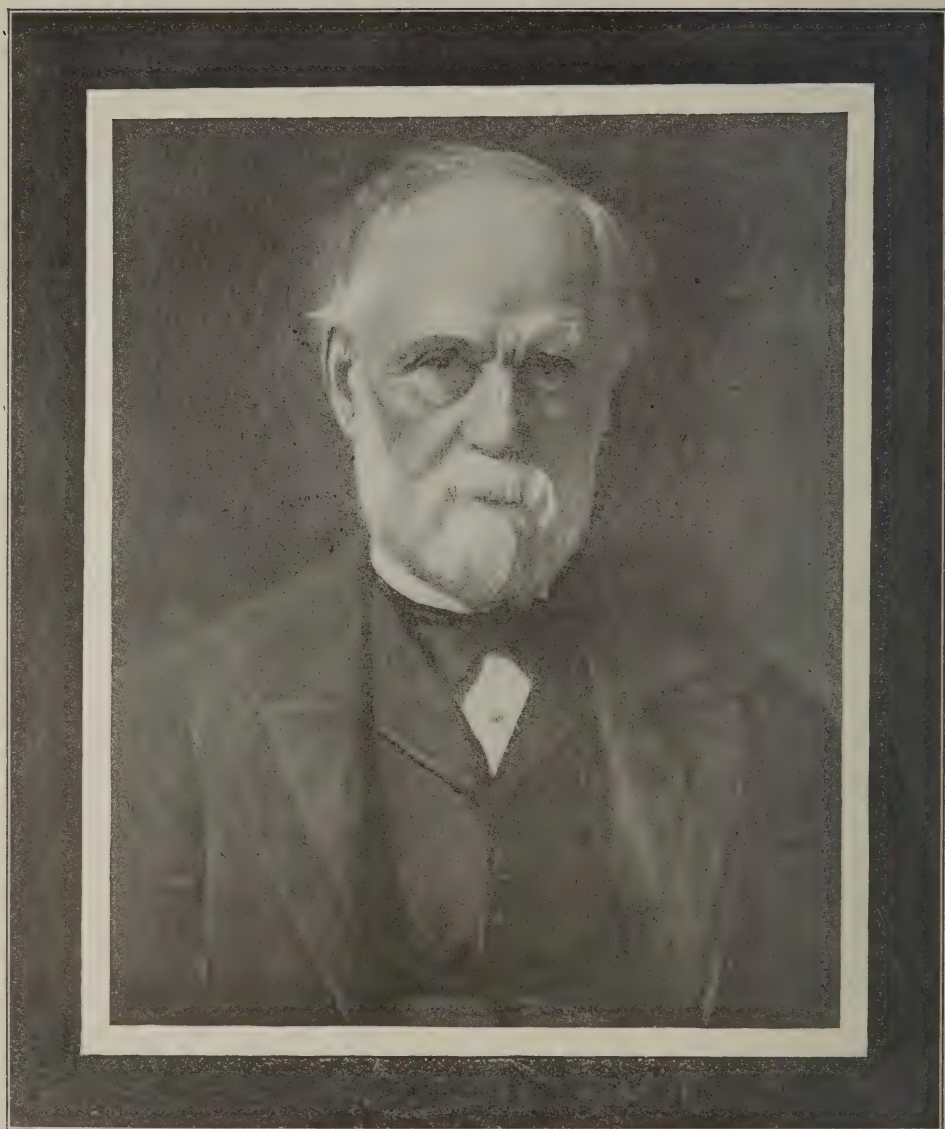

THE LATE ABRAM STEVENS HEWITT.

"The Electrical Age" adds its word to the editorial expressions of sorrow at the death of Abram Stevens Hewitt, the friend of the State. Wise in counsel, fearless, eminently just, sturdy in thought, speech and character, the impress of his life will continue far beyond his generation. Especially will his loss be felt among his co-adjutors on the board of the Cooper Institute, where his unvarying interest and sagacious liberality ever contributed to the end that the spirit of its great founder should live in its work.

THE ELECTRICAL AGE

NEW YORK

VOL. XXX

FEBRUARY, 1903

No. 2

Nikola Tesla, His Work and Unfulfilled Promises

By LAURENCE A. HAWKINS, E. E.

THAT commendation on the part of the public which we call fame is a prize struggled for throughout the world. It is as distinctly valuable as a mine, a 20-story building or any other property, and, in the estimation of many, great fame is of more value to its possessor than would be any section of mines or 20-story buildings. It is wise, then, on the part of society to see that this valuable thing, fame, is distributed justly.

Ten years ago, if public opinion in this country had been required to name the electrician of greatest promise, the answer without doubt would have been "Nikola Tesla." To-day his name provokes at best a regret that so great a promise should have been unfulfilled. In ten years the attitude of the scientific press has passed from admiring expect-

tancy to good natured banter and at last to charitable silence. In 1892 a leading electrical periodical of this country contained the following ("Electrical World," Vol. 19, p. 20):

"During the past six months Mr. Nikola Tesla has been steadily at work developing the beautiful principles that he enunciated in his striking lecture before the American Institute of Electrical Engineers. In his skilful hands the experiments have extended far beyond their merely theoretical importance in the direction of important practical applications. The revolutionary character of his methods will make any extensive application of them of unique interest." In 1898, the same journal, speaking of Tesla's latest patented scheme, says ("Electrical World," Vol. 32, p. 466): "Mr. Tesla, if correctly re-

ported, previously proposed to wobble the earth's charge for man's ignoble uses, but he now, if these things can be taken seriously, has designs on the universe. The price of copper remains in the neighborhood of 11 cents, however." In 1900, a description of a Tesla patent which if practicable would revolutionize the electrical industry, is printed without one word of editorial comment. ("Electrical World," Vol. 35, p. 792.)

Tesla's career, since the time he first stepped into prominence by his lecture before the A. I. E. E. in 1888, naturally divides itself into three periods, which may be designated as the rotary field or patent period, the high voltage and high frequency or lecture period, and the present or newspaper period. It will be well to consider these separately in an endeavor to arrive at a just estimation of the man's work and of the value of his contributions to the engineering or scientific world.

Prior to 1884, the alternating current system of distribution, though older than the direct current system, was in little use. Gramme had taught the world how to build a satisfactory direct current commutator. Direct current seemed to have all the advantages of alternating current and would perform many services for which the latter was not suitable, notably electrolytic work. But in '83 and '84 Gaulard showed that the well known Ruhmkoff coil could be used to transform alternating current from high to low voltage, permitting of great economy in line wire, and he built and operated his transformer for lighting.

In 1885 Zipernowski & Deri produced a transformer of high commercial efficiency, and showed how to obtain excellent regulation, impossible with Gaulard's series system, by proper connection of the primaries in parallel.

From this time alternating current began to be more used for electric lighting. One of the objections to the system was that there were no small self-starting motors that would operate efficiently on it. Accordingly, when Tesla announced, in May, 1888, that he had solved this motor problem, he at once became one of the most prominent figures in the engineering world. His solution was a theory of the combination of two or more alternating currents of different phase to produce a resultant rotating magnetic field. This same theory had been published in Italy a few weeks prior to Tesla by Ferraris. ("L'Elettricità," April 22, 1888.) Ferraris, however, contented himself with publication of the theory, while Tesla patented it, and followed up his first patents with a mass of other patents describing every conceivable construction and mode of operation that could in any way be imagined to embody his rotating magnetic field. It is for this reason that the rotating field theory is associated in this country with the name of Tesla rather than with that of Ferraris, although the contrary is the fact in every other country.

The idea of a rotating magnetic field as the resultant of two currents was not novel. It had been produced by Bailey ("Phil. Magazine," October, 1879) in 1879 with commutated direct currents, and by Deprez ("La Lumière Electrique," December 8, 1883) in 1883 with alternating currents. It is scarcely conceivable that the application of these experiments would have escaped the eyes of the engineering world when the greater efficiency of polyphase alternators over single-phase alternators forced the former into general use. But that time had not come in 1888, and the motors described by Tesla, even if they had been commercially efficient struc-

tures, could not be operated on the circuits then existing.

Like Edison's three-wire system, the rotating field must have been obvious when changed conditions called for its application, but in 1888 it was not what was wanted. As Swinbourne said at the time ("Electrician," Vol. 21, p. 342): "The low efficiency is not at all the chief objection to the scheme. The whole arrangement is impracticable, as it demands special alternate-current generators and leads. Until Mr. Tesla can produce a motor which will work on alternate-current circuits as they are, and do that efficiently even with varying loads and without difficulty in starting, he can hardly be said to have solved the problem." The achievement of the Tesla and Ferraris publications was not the solution of a problem presented by existing conditions. They assumed non-existent and, at that time, impracticable conditions, and then applied the obvious principle of the rotating field of Bailey and Deprez. Had not experience subsequently proved the polyphase generator more efficient than the single phase, the rotary field of Tesla and Ferraris, like that of Bailey and Deprez, would never have become of more than academic interest.

In time the polyphase generator did prove its superiority per se, and brought polyphase motors of different types with it into commercial use. But engineering to-day owes Tesla no more than it owes Ferraris, Deprez or Bailey, for Tesla never produced a commercially successful motor. As the demand for polyphase motors gradually came into existence he worked hard to produce a commercial motor, but it did not appear in the market. The motors of the so-called fundamental patents failed absolutely to meet commercial conditions. Though the later Tesla patents describe

multitudinous modifications, Tesla himself, with practically unlimited means at his disposal, seems to have failed to produce a commercial self-starting motor for power purposes. Undoubtedly Tesla's theory of magnetic laws, as shown in some of his patents depending on so-called magnetic screening and on reducing iron losses by removing the iron, was an important factor in his failure. But other engineers equally failed to reduce those patents to practice, although on one occasion, according to the sworn testimony of a prominent engineer, \$100,000 was offered if he would make the Tesla motor operate successfully.

Two widely different classes of alternating-current motors are in general commercial use to-day. They are known as synchronous motors and induction motors. The two differ radically in principle of design, in theory of operation, in method of manipulation, in the necessary accessory apparatus and in adaptability to different kinds of work.

The synchronous motor is simply an alternating-current generator with its function reversed. The same machine, with no change whatever, runs equally well as generator or motor. This is true of either single phase or polyphase. The polyphase generator is two or more single-phase machines wound on the same frame, and the same is true of the polyphase motor. When the electrical world had polyphase machines given it, and was told that alternating-current generators, like direct-current generators, were reversible, it knew all that was necessary for the successful operation of polyphase synchronous motors. And it had the machines (United States patent, No. 218,520, Gramme; "Electrician," October 28, 1882, p. 565; Gordon's dynamo electric machine) and it

had the knowledge ("Jour. Soc. Tel. Eng." and "Electricity," Vol. 13, p. 496 and p. 515; "Electrician," November 15, 1884, p. 11; "Electric Illumination," by Dredge, London, 1882, Vol. 1, p. 69; "L'Electricien," August 1, 1884, p. 131; United States patent, No. 390,439) years before Tesla and Ferraris published the rotating field principle in 1888.

The synchronous motor, however, finds its applications in conditions of large power and continuous running. Those conditions are furnished by the great long-distance systems of power transmission of to-day, and it is only in such systems that the synchronous motor is or ever has been used. No such systems existed in 1888, and it was for this reason that though the reversibility of the alternating-current generator was known, it had never been utilized. The machine was there, but the conditions for its use were lacking. What was wanted then, and is wanted now, for general distribution and subdivision of power, was a small self-starting motor. This requirement is met by the "rotary field" or "induction" motor of to-day.

The man, in my opinion, to whom the induction motor is chiefly due is Dobrowolski. He was the first clearly to perceive the theory of its operation and the requirements in its design. To produce the maximum action of the alternating currents on the other member he perceived the necessity of a minimum magnetic air gap. He gained the desired result, among other things, by imbedding the conductors in the iron, and his motor was a success. The first commercially successful induction motor of any size was the one built by him and exhibited at Frankfort in 1891. His designs were successfully copied in this country, and the induction motor of to-day became a fact.

After Tesla's apparent failure in motor production he turned to more promising fields. In 1891 he burst upon the electrical world with the first of a series of the most remarkable lectures ever delivered before a scientific audience. The experiments shown were fairly startling. Lamps and motors were operated on open circuit with a single-line wire. Lamps were made to burn brightly when short-circuited by a heavy copper bar, while exhausted tubes were brought to incandescence without any wire near them. Tubes were lighted by merely approaching them with the hand. Beautiful flames of varied appearance were made to leap from many objects, even from the hand of the lecturer himself.

Before the eyes of the startled spectators Tesla touched both terminals of a 200,000-volt transformer, with no more serious result than the production of the flames aforesaid. And throughout the lecture vague hints were offered of the tremendous possibilities exposed by the experiments—possibilities of obtaining unlimited light and power anywhere on the earth's surface, not by means of expensive wires from costly central stations, but by taking the energy directly from the earth itself or from the circumambient ether.

The public was astounded. Popular opinion, ever ready to ascribe the most impossible attributes to that vaguely understood force, electricity, hailed the lectures as disclosing a new era of wonders and Tesla as the last and greatest of electrical wizards. Even the eye of science was dazzled by Tesla's brilliant flames, and the most extravagant tributes were poured upon him. As stated in the London "Electrical Engineer": "No man in our age has achieved such a universal scientific reputation in a single stride as this gifted young electrical engineer."

It was asserted that similar effects to those shown by Tesla had previously been produced by Crookes, Hertz, Rayleigh, Spottiswood, Lodge, De La Rue, Kennedy and Thomson, some of those effects having been patented nine years before the first Tesla lecture (British patent, No. 4,752, Rankin Kennedy, 1882). But Tesla had made his experiments more spectacular by the use of higher voltages and higher frequencies, and the difference in degree passed for novelty in kind. It is true that the lectures abounded in fallacies and absurdities, as, for instance, Tesla's favorite theory of magnetic screening ("Inventions, Researches and Writings of Nikola Tesla," p. 185), his misconception of harmonics (Id., 187), his inexplicable statement regarding Arago's experiment (Id., 233), and even a gross misunderstanding of the fundamental law of physical science—the conservation of energy (Id., 147)—but all were overlooked or forgiven. Few, if any, measurements are recorded in the lectures; nor is there more than the feeblest attempt at even orderly sequence in the experiments, but spectacular sensationalism was accepted as a substitute for scientific methods. No attempt at any commercial adaptation of the experiments is described, but, instead, Tesla's vague hints at possibilities won him the reputation of prophet of the new era.

To-day, as we look back on those lectures of ten years ago and the developments since then, it is hard to understand the scientific enthusiasm Tesla aroused. Have any useful results ever come from those famous experiments? Instead of Tesla's high frequencies, the tendency has been steadily to lower frequencies. Instead of using static effects for power transmission, the chief problem on modern long-distance lines is to diminish those very effects. The elec-

trostatic light is still a laboratory toy, while two wires and a filament are still used in commerce. Central stations still produce their power and distribute it through their mains. The prophecies of those lectures and articles are still unfulfilled, and their suggestions forgotten or disregarded. But ten years ago those who could see beyond the glamour of the Tesla tubes were few. Even then, however, there were some who regarded the lectures in the less spectacular light of science. The London "Electrical Review," in an editorial expressive of some bewilderment at the chaotic mass of experiments and of an inclination to suspend judgment until Tesla should have opportunity for further explanation through the press, calls attention to the fact that Tesla's work was not in a wholly unexplored field. (London "Electrical Review," Vol. 30, p. 184.) "The Electrician" at first called attention to the fact that the experiments were not new, but consisted "in repetitions of well-known effects on a large scale" ("Electrician," Vol. 28, p. 395), and later expressed itself conservatively as follows ("Electrician," Vol. 31, p. 139): "If a few quantitative determinations of current, voltage, or even of frequency, had been given in the lecture it would have had a definite scientific value. To reduce even one out of the 50 experiments to a complete reasearch would be worth all the other 49 brilliant and suggestive demonstrations." And "Industries" said (London "Electrical Review," Vol. 29, p. 193): "We have no desire to pick out weak points in such an interesting lecture, but we think that any one who read Mr. Tesla's articles must have had great difficulty in understanding his repeated idiomatic statements. Is it asking Mr. Tesla too much, holding the prominent position he does in the American electrical world,

when we say we think if he omitted some of the confusing passages his lecture would be much better understood, and if he would keep ideas anent electro-magnetic theory of light, also Hertz and Dr. Lodge from his work, his experiments would be clearer, as well as more interesting. We hope Mr. Tesla is correct when he surmises that the future light may be produced by vacuum tubes, but we believe the subject has been thoroughly searched out ere this by many inventors without a result which has been very promising." In this connection, it might be mentioned that small acknowledgment of the work of Hertz or Lodge occurs in the lectures. The ambiguity referred to in the above quotation, and certainly existing in the lectures, has been passed over in this paper, as in Tesla's case a certain lack of facility in handling English may account for what in another would seem an attempt at mystification.

Had Tesla's labors ended with these lectures perhaps he would have received less criticism in these later days. They seemed to teem with brilliant possibilities. But the applause they had evoked seems to have resolved him to keep himself before the public at all hazards. In the succeeding years each new idea or fad in the electrical world was eagerly seized upon by him and made the pretext for rushing into print, at first in the technical papers, and later, as the engineering press began to regard his effusions askance, in the non-technical daily papers, the adoption of the latter medium being accompanied with increase in sensationalism. When X rays were holding the popular attention, he dabbled in them and published his results. ("Electrical World," Vol. 27, p. 343.) When the Wehnelt interrupter attracted the interest of scientists, Tesla immediately leaped into notice. As the Lon-

don "Electrical Review" says (Vol. 44, p. 653): "Tesla lets himself out on the Wehnelt interruption in the 'Electrical Review' (New York), March 15th. He invented this device two or three years ago. This belated publication in our contemporary would not, according to the generally accepted code, secure to Tesla the credit of being the inventor; but Tesla evidently does not regret this, since he considers there is not merit in the invention." And again (at p. 733): "Tesla has expressed a somewhat ungenerous contempt for the Wehnelt break, which has recently given such remarkable results in the hands of experimenters here and abroad. Its inferiority to Tesla's break appears to be known as yet only to Tesla; in simplicity, at least, it is certainly superior."

When the efforts of Marconi, Lodge and Slaby brought their first achievements in wireless telegraphy before the world Tesla had nothing but pity for their puerile efforts. When Marconi was ready to send a signal a few hundred miles, Tesla was ready (in the papers) to transmit thousands of horsepower the same distance. ("Century Magazine," June, 1900.) When Marconi was attempting to signal across the Atlantic, Tesla had already (in the papers) received a signal from Mars. (New York "Sun," Jan. 3, 1901.) Before the enthusiasm over the Spanish War had had time to cool, Tesla had published a description of his torpedoes, which would revolutionize warfare. (New York "Sun," November 21, 1898.) The "Electrical Engineer" quotes the following from Tesla's signed article (at p. 514 of vol. 26): "We shall be able, availing ourselves of this advance, to send a projectile, at a much greater distance; it will not be limited in any way by weight or amount of explosive charge; we shall be able to submerge

it at command, to arrest it in its flight and call it back, and to send it out again and explode it at will; and, more than this, it will never make a miss." The editorial comment follows: "When we are expected, wide awake and in our sober senses, to accept in silence such an utterance as that quoted above, or that which describes as 'a possibility' the operation of a distant torpedo boat by the mere exercise of the will, we refuse point blank, and we are willing to face the consequences." The significance of this comment lies in the fact that this paper had always been so ardent a supporter of Mr. Tesla that it had been said to have made him and his reputation, and from the pen of its editor-in-chief had come only four years previous the greatest tribute Tesla ever received. "Inventions, Researches and Writings of Nikola Tesla," by T. C. Martin.

It was of this torpedo boat invention that Tesla said ("Criterion," November 19, 1898): "Had I nothing else to show for a life-work, this would put the laurels of everlasting fame on my head." It was of this same invention that Prof. Brackett, of Princeton, said ("Electrical Engineer," Vol. 26, p. 491): "The shortest, most correct and most complete criticism which I can make in reference to this bold boast is that, what is new about it is useless, while that which is useful had all been discovered by other scientists long before Tesla made this startling announcement." It was of this invention that Prof. Dolbear, of Tufts College, said ("Electrical Engineer," Vol. 26, p. 491): "This last so-called invention of Nikola Tesla's is a very pretentious affair, and it is so incredible that the story is not to be believed until the work is actually done. The announcement is most amazing, and, coming as it does from Tesla, scientists are

all the more chary about accepting it. During the last six years he has made so many startling announcements and has performed so few of his promises that he is getting to be like the man who called 'Wolf! wolf!' until no one listened to him. Mr. Tesla has failed so often before that there is no call to believe these things until he really does them."

Lack of time and space forbids more than a passing reference to the Tesla engine which was to revolutionize steam engineering; the "discovery" of the variation of capacity with elevation, which was to necessitate the rewriting of all electrical literature ("Electrical World," Vol. 37, p. 201); the torpedo boat, which was to be manipulated at the Paris Exposition from Tesla's laboratory at New York, but which failed to appear; the Tesla oscillator, which was to enable central stations to dispense with wires ("Century Magazine," June, 1900); the method of insulation by refrigeration, which was to give the highest efficiency to transmission with wires ("Western Electrician," Vol. 27, p. 122); and even the message actually received from Mars (New York "Sun," January 3, 1901) must be passed by with merely the comment made by Prof. Fessenden ("Electrical World," Vol. 37, p. 165) that "only the crassest ignorance could attribute any such origin" to the so-called signals.

From the mass of imaginative literature that has recently issued from Tesla's ever-ready pen a single one is here selected for comment. It is chosen both because it includes a large number of Tesla's vagaries, and also because its publication in a magazine of some standing drew more attention to it than was bestowed on others appearing in the more sensational daily press.

"In the 'Century Magazine' for

June, 1900, Mr. Tesla printed a long article, superbly illustrated with cuts that had little or nothing to do with his subject, which dealt with a few electrical matters and also with philosophies and social problems, upon which he freely expressed a jumble of trivial, ignorant, pretentious and erroneous opinions." ("Popular Science Monthly," Vol. 58, p. 437.) This article attracted widespread attention, and if Tesla in truth experiences a feeling of satisfaction at adverse criticism, as he once stated in the New York "Sun," he must have enjoyed keen ecstasies on reading the comments it evoked, as the above quotation would indicate. Nor did the "Century" itself escape criticism. In publishing such pseudo-scientific productions such magazines "descend to a footing with the Sunday newspaper. They evidently do not know science from rubbish, and apparently seldom make any effort to find out the difference." ("Popular Science Monthly," July, 1900.) A brief review of the article will assist to an appreciation of the justice of the criticisms, and, perhaps, to a truer estimate of Tesla's character and the value to be put upon his work than could otherwise be obtained.

The problem treated is that of humanity as a mass acted on by forces, one tending to acceleration, the other to retardation. The three methods of increasing the energy are the increase of the mass, the diminution of the retarding force, and the increase of the force making for progress. The treatment of the first method need not be considered here. It consists merely in the assertion of well-known sociological principles. It is the second method that introduces the first novel element in this remarkable paper. War is justly considered an important factor in the retarding force, and the means of its elimi-

nation are unique. Battles will no longer be waged by human beings, but, instead, by machines, by Tesla's "telautomatons."

Rival fleets of these beneficent Franksteins will clash in mid-ocean for the determination of maritime supremacy, their maneuvers being controlled from physicists' laboratories on shore. These long-distance weapons, the harbingers of universal peace, are already perfected. Another more wonderful type is on its way. (Quoting from the "Century" article): "An automaton may be contrived which will have its 'own mind,' and by this I mean that it will be able, independent of any operator, left entirely to itself, to perform, in response to external influences affecting its sensitive organs, a great variety of acts and operations as if it had intelligence. It will be able to follow a course laid out or to obey orders given far in advance. It will be capable of distinguishing between what it ought and what it ought not to do, and of making experiences, or, otherwise stated, of recording impressions which will definitely affect its subsequent actions. In fact, I have already conceived such a plan." Truly, Tesla's science is stranger than fiction. This noble scheme for universal peace must be passed by with a single quoted comment ("Popular Science Monthly," July, 1900): "Inasmuch as the interest in this telautomatic warfare is to be purely aesthetic, it would seem as if international bull fights or kite flying, or spelling matches, or potato races, might do as well, and have the added advantage of leaving Mr. Tesla's expectations free to wander among the following prospective discoveries."

The methods of increasing the accelerating force comprise the third and largest division of the "Century" article. This section is introduced by the

wise but trite statement that all energy is derived from the sun. Three ways of manipulating this energy efficiently are suggested—the cold coal battery, direct utilization of the energy of the ether, and transmission of power through the ether. The first method is introduced by a digression on the value of iron and the wastefulness of its present production, with incidental reference to a new method of manufacture perfected by Tesla in which water is the fuel, having previously been decomposed electrolytically. This method of reduction is stated to be “cheaper than by any of the adopted methods.” The digression is continued by a reference to aluminum and its prospective value to mankind. Then electric transmission is considered and the following remarkable statement appears: “Steamers and trains are still being propelled by the direct application of steam power to shafts or axles. A much greater percentage of the heat energy of the fuel could be transformed in motive energy by using, in place of the adopted marine engines and locomotives, dynamos driven by specially designed high-pressure steam or gas engines, and by utilizing the electricity generated for the propulsion. A gain of 50 to 100 per cent. in the effective energy derived from the coal could be secured in this manner. It is difficult to understand why a fact so plain and obvious is not receiving more attention from engineers. In ocean steamers such an improvement would be particularly desirable, as it would do away with noise and increase materially the speed and the carrying capacity of the liners.” This difficulty of Tesla’s must have been cleared away by a paper of Prof. Durand’s (“Marine Engineering,” July, 1900), who points out that in the case of a liner of 25,000 horse power, Tesla’s scheme would result in loss of about

one-third of carrying capacity, besides a loss of about 2,500 horse power due to two transformations of energy, hence a loss in speed of one-half to three-quarters of a knot. As Prof. Durand remarks, “The increase of carrying capacity referred to at the close of the quotation would be, therefore, of a character not likely to commend itself to the stockholders or board of directors.”

The cold coal battery itself receives scant notice. Apparently it is one of the few things Tesla has not yet perfected.

The treatment of the method of deriving energy direct from the ether contains numerous suggestions. Brief reference is made to the windmill and the solar engine. Then two perpetual motion possibilities are described. The first is a disc kept in motion by a gravity screen. A critic regrets (“Popular Science Mo.,” July, 1900) that “Into further particulars concerning the nature of such a screen Mr. Tesla does not enter, though it would seem a matter well fitted to engage his peculiar gifts.” The second is a perpetual heat engine, regarding which the critic just quoted says: “We should thus employ ‘an ideal way of obtaining motor power’ and incidentally rebuke the narrow minded physics of Carnot and Lord Kelvin.” This section ends with a mention of the Tesla mechanical oscillator and a reference to liquid air.

The third and last method, that of utilizing the ether as a bus bar, is stated to find greatest favor in the author’s eyes. Mention is made of his experiments with one wire and with none, with wobbling the earth’s charge and with electrifying the upper strata of the atmosphere. The secret of tuning for wireless transmission is revealed and the errors of the experiments of Hertz pointed out. The possibility of signaling to Mars is asserted, and the facts of

power transmission are stated as follows: "The experiments have shown conclusively that, with two terminals maintained at an elevation of not more than 30,000 to 35,000 feet above the sea level, and with an electric pressure of 15,000,000 to 20,000,000 volts, the energy of thousands of horse power can be transmitted over distances which may be hundreds and, if necessary, thousands of miles." No data as to methods of ballooning or of supporting wires at this elevation are given. Instead, the article closes with a quotation from Goethe. This quotation, with its reference to fulfilment, furnishes a most strikingly complete and sarcastic, though evidently unconscious, comment on the whole ludicrous production.

A perusal of the article forces one to coincide with the verdict of "Marine Engineering," whose editor describes it ("Marine Engineering," July, 1900) as the "handiwork of a cerebrose individual—a bombastical genius who has illumined unknown fields of imaginative science with his intellectual searchlight, and is willing to permit the gaping world of ignorance or complaisance to peep in and wonder, the credulous editor drawing the curtain. This dazzling contribution to modern unscientific research reads like nothing so much as an essay

on Christian Science, so profound is it in the ambiguous nothingness whereby it leads through the intricacies of incoherency into the climax of absolute assnity."

Enough has been given to indicate the reason for the standing that is Tesla's today in the scientific world. Not even the brilliancy of suggestion and experiment contained in his early work, not even the persistent efforts of powerful friends, moved by their commercial interests to magnify and exalt the value of his patented inventions, could avert the discredit to his reputation as a scientist brought upon himself by his wild struggles for notoriety. He has been condemned by his own extravagant boasts, never followed by the realization of their claims and often revealing a total misunderstanding of the very elements of physical laws.

Tesla is still a young man, and those whose sympathetic expectation was aroused by his early work still hope that he will turn from the gaudy notoriety of the Sunday newspaper, and by conscientious work give at last one complete useful invention that may be honestly set to his credit, and that may make its influence felt on the progress of engineering science.



Peter Cooper Hewitt's Selective Converter

IT has been known for a long time that certain media presented a much easier path to a current when passing in one direction than when the flow is reversed. Mr. Peter Cooper Hewitt's investigation in the field of this phenomena has produced for the scientific world a new device whose far-

reaching influence in the electrical transmission of power cannot to-day be appreciated. The basis on which this apparatus works is when an alternating current is caused to jump through a space filled with mercuric vapor of a given degree of attenuation it presents a ready passage to certain portions of the wave, whereas other portions of the wave are damped back or form a selective electric valve, which allows impressed electromotive force of a certain character only to flow through the apparatus. The practical utility of such a device becomes immediately apparent, for it forms a method of producing a direct current from an alternating circuit, and extends the field of alternating current transmission into those fields which have required unidirectional currents, such as the storage battery and electrolytic work.



Fig. 1.

reaching influence in the electrical transmission of power cannot to-day be appreciated.

The basis on which this apparatus works is when an alternating current is caused to jump through a space filled

The device used for this selective con-

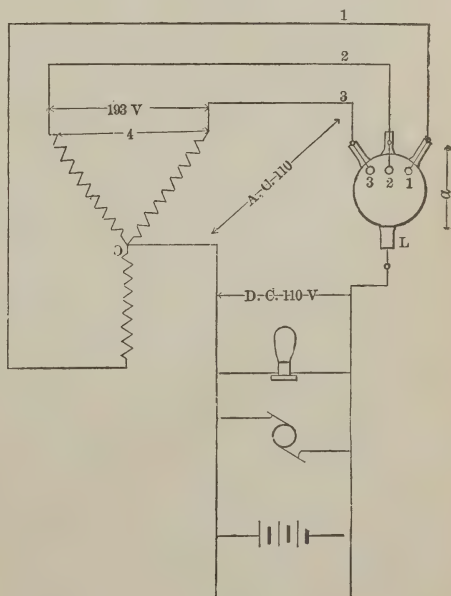

Fig. 2.

verter is as simple as an incandescent lamp. (See Fig. 1, device for use on three-phase circuits.) The containing shell in the device exhibited is made of glass and of spherical shape. Into this shell project the terminals from the alternating-current circuit, whereas the terminal for the direct circuit is taken from a separate terminal at the bottom of the globe. A starting terminal is also introduced into the globe, which is used for starting the converter, and to this a higher tension is first applied. After being once started the action is continuous as long as the impressed alternating electromotive force is ap-

plied. Fig. 2 shows diagram where used on three-phase circuits.

This selective converter is surprisingly small for the energy it converts. One, rated at eight kilowatts, the vapor globe is seven inches in diameter and weighs not over four pounds, whereas a rotary converter to do the same work would weigh over 700 pounds.

We feel that Mr Hewitt has made a great stride, and has, at least, thrown down the barrier which separated the alternating and direct-current fields, and it is hard to predict at this early date the influence on the art this radical innovation will make.

The Electric Cottage

By JOHN W. FERGUSON.

“LUX, et preterea nihil.” When Mr. Edison, in 1878, first developed the theory of the incandescent lamp, lighting was supposed to constitute the be all and end all of the discovery, and few, if any, realized the possibilities of the use of electric current. But since then the times are changing, and we are changing with them. Were one to anglicize that quotation on the lines adopted by the Commonwealth Electric Company, of Chicago, it is but fair to assume that he would say, “Light, and after that consult us”; and, to judge by the policy of that company, as evidenced in its advertising schemes, this would seem to be its slogan. The latest exemplification of this theory is the “Electric Cottage,” and we feel that a short article devoted to this subject will be of interest, and perhaps benefit, to our readers.

The idea originated in the brain of the contract agent of that company, and the details were carried to a successful issue under his personal supervision. As an

educational demonstration of the many advantages to be derived from the use of electricity in the residence it probably surpasses any effort heretofore made on the part of a central station company.

The scheme of the cottage is outlined as follows: The cottage itself, being constructed for display in the residence districts, was built on the lines of artistic



The "Electric Cottage."



Office in "Electric Cottage."

and architectural beauty. It is a frame structure, the foundation being painted to imitate brick, and the superstructure being paneled; the outlines are stained a weathered oak. An artistic "bow" window in the front serves the purpose of providing space for an attractive display of beautiful parlor and banquet lamps, shades, reading lamps, and what not, to the approaching visitor. The commercial purpose of the cottage is shown by an electrically illuminated sign placed at the apex of the roof bearing the inscription "Electric Light." The entire structure is made in sections, to permit of its being taken apart and moved from place to place, the intention being to locate it for short periods in different localities. The interior is a single room 12 by 18 feet, the side walls being 12 feet high, two windows on each side serving to light the room by day. The interior

is fitted with glass cases, in which are displayed the various household appliances that can be operated by electricity. Here the visitor may see an electric chafing dish, on which a luscious "rarebit" may be prepared in three minutes; and, realizing that the "electric heating pad" is an assured fact, may bid defiance to sudden pains and ills when he knows that relief is assured in less time than it would take to prepare the old-fashioned hot-water bottle, while the young lady recognizes the fact that, when she is preparing for a reception, the "electric curler" will not only perform its duty instantaneously, but will eliminate forever all danger of singeing or soiling a "woman's crowning glory." Numerous sizes and varieties of electric fans make the cottage especially inviting in the height of summer. These are but a few of the contrivances—in all some 75 varieties—



One View of Reception Room.

displayed in the cottage. Suspended from the ceiling in the center is a beautiful chandelier, especially designed for the electric cottage, equipped with the various forms of pendant switches, while electric lighting brackets of numerous styles adorn the walls. The appliance which probably attracts the most interest is an electrically operated sewing machine, and it is fair to say that the financial benefit derived by the company from the investment may be attributed to this apparatus more than to any other displayed, as the visitor realizes at once that the weariness and troubles resulting from the use of the old-time pedal-operated machine in household sewing are forever relegated to the dim and dreary past.

A desirable location having been selected, and the cottage having been placed thereon, a neatly engraved invitation to call is sent to each resident in

the neighborhood. One of the company's agents is always in attendance to explain the operation of the various apparatus and to dilate upon the many advantages to be derived from the use of electricity for lighting and kindred purposes. Reports are sent each day to the main office, showing the number of visitors, the number of sales of apparatus and the number of contracts for electricity entered into with parties who had theretofore used other means of illumination. Mr. Gilchrist, the contract agent of the company, informs us that during the past summer an average of 125 persons have visited the cottage daily, and that the amount of new business entered on the company's books as a result of the cottage advertising has demonstrated that the experiment is an assured and a permanent success.



Another View of Reception Room.

Storage Battery Development

AMONG the recent exhibits of storage batteries at the Automobile Show in Madison Square Garden, the exhibit of the Electric Storage Battery Company of Philadelphia attracted considerable attention; the latest improvements in automobile battery construction was interestingly shown and explained to visitors. It is understood that the battery now furnished by this company for the small runabout is guaranteed to make 40 miles on a single charge and the cost of maintenance has been much reduced.

The Edison Storage Battery was exhibited for the first time at this show, and all the storage battery critics could be found here, asking questions and shrugging their shoulders, but all agreeing that the mechanical design was a delight to the eye.

The illustration shows one complete cell of the new perfected Edison Battery, with the front side of the jar removed to show the arrangement of the plates. On the top of the jar is a spring stopper with a rubber flange similar to a soda water bottle stopper for filling the jar with distilled water from time to time, to replace what may be lost by evaporation; a very ingenious funnel with an automatic float valve is furnished, so that the exact amount of water may be added leaving a considerable space between the surface of the water and the top of the jar for accumulation of gases. The jar being hermetically sealed, a vent is furnished for the escape of the gases, which consists of a nipple about 3-4 of an inch in diameter, having a gravity valve in the bottom, which valve is lifted

as soon as enough gas is generated to overcome the weight of the valve. The gases escape into a small chamber in the nipple, which is shown on the right hand top of the jar; this chamber at its top has a small partition in which are



Edison Storage Battery.

drilled two small holes about 1-64th of an inch in diameter, through which the gas must pass; it then passes through a series of very fine metal screens which

are secured in the nipple or vent, thus breaking up the gases and separating the potash from the gas, which returns by gravity to the cell. It will be recalled that one of the serious drawbacks to the previous battery was the carrying over with the gases a quantity of the potash used in the solution. It is claimed that 460 pounds of this battery in a Baker runabout carrying one person would, on a single charge, run 100 miles at an average speed of 10 miles per hour, on a fairly level New Jersey road, while a battery of 378 pounds would do the same work on an 80 mile run.

The battery discharge rate is claimed to be far in excess of automobile requirements, and that no injury can result from heavy charging or discharging. The battery may be fully charged from practically zero to full in one hour.

The jar and plates are made of a special quality of steel—nickel plated to prevent rusting, this being the only reason for the nickel plating. The insulation frames are made of vulcanized rubber.

The active material in the positive plate is a combination of nickel and graphite, while that of the negative plate is oxide of iron. The electrolyte is a 20 per cent. solution of potash, which never escapes and the cell has only to be refilled with distilled water.

A separator or vent separates the solution, which runs back into the cell, from the gas which escapes. The illustration shows a 200 watt capacity cell, of a net weight of 17 1-4 pounds, indicating the position of the plates in the cell; on the top of the cell will be seen the connector, whose function it is to connect one pole of one cell to the pole of the other adjacent cell.

Up to this writing the battery has been wholly within the control of Mr. Edison. If, as now claimed, the battery is commercially practicable (inasmuch as more is claimed for it than any other battery now on the market) let us hope that Mr. Edison will not struggle longer for perfection, but will promptly give the public what they are always seeking—Something better.



Equalizers for Direct Current Dynamos

By ALPHONSE A. ADLER

MANY electric light and power plants are situated so as to have a load that is variable, requiring small amounts of energy for a certain time, and at other times, perhaps the entire output of the station. In order to run such a plant as economically as possible, it becomes desirable to have the machines run up to their full load capacity, or as near to full load as possible. The efficiency of dynamos and engines is generally highest at this point. If several machines are in the station, one is selected to carry the load, and as soon as the load becomes too great, another is added, or the load is transferred to a machine of larger capacity.

In many cases this transfer of load from one machine to another must be done without any change in the line voltage. It is the function of the equalizer to do this safely, and this article has for its object the description of those methods found most satisfactory in practice.

When two machines are required to supply the same electric circuit, they must have the same voltage when they are connected together, as the load will largely be taken by the machine having the higher voltage. If this voltage difference is considerable, the higher voltage machine may remove all the load from the other, or may even drive the other as a motor. This "motoring," as it is called, may be dangerous to the machine and the safety of the attendants.

Two shunt dynamos, having equal voltage, may be connected to the same bus-bars, if they are similar in construc-

tion, or have, as we say, similar "characteristics," the load will divide about equally between them. Should the machines be of different capacities, then the load should be divided among them in proportion to their capacities. This is done by varying the field resistance of the dynamos. If it is required to increase the load on the dynamo, some field resistance is cut out, and vice versa for a decrease in load. This process of coupling two or more dynamos together is called "paralleling."

There is some tendency of the shunt dynamo to operate in parallel with others, for should one machine momentarily take a larger load than is allotted to it, its drop in E. M. F. due to the armature resistance, will be increased, and consequently its terminal voltage lowered. The other machine, which has some of its load removed, will rise in terminal voltage due to the reverse of the other, that is, increase in voltage, on account of decreased drop. This will cause the higher voltage machine to take back some of the load, and thus produce the equalizing effect. This inherent tendency of the shunt dynamo to operate in parallel is slight, and cannot be depended upon in practice, for any extent in load variation. It is permissible only in such installations that can afford to give them constant attention.

Two shunt dynamos can also be made to operate in parallel to some extent by having the driving belts slack. Figure 1 shows a countershaft G carrying two pulleys E and F, driving dynamos A and B, by the belts C and D. Any increase in the load on one machine will cause

its belt to slip a little, which means a decrease in speed and likewise a decrease in voltage. Decrease in voltage means less load, and the other machine will be

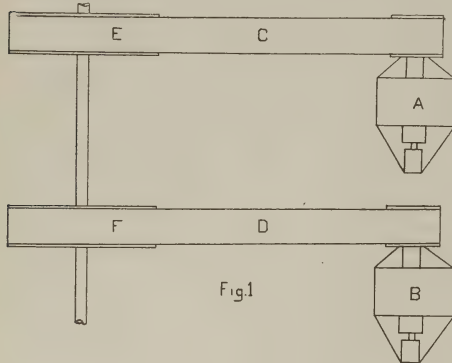

forced to take back some of the load it has parted with. This method is satisfactory in practice as far as it goes, but it prevents both machines to run at their full load unless the tension is increased of the belts, and then this equalizing tendency will fail to some extent. The machines should be of about equal capacity. This method is used in some of the older railway and lighting plants, but is rapidly becoming obsolete.

Two dynamos may also be operated in parallel by having the armatures rigidly connected, so that they revolve at the same speed. This practically makes one armature of the two, and such an outfit will necessarily run satisfactorily. However, the idea of rigidly connecting them together is such as to make it

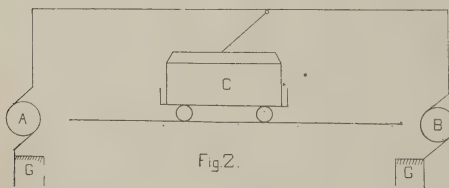

a very objectionable feature in modern power plant practice, and perhaps beyond the experimental stage is never used.

Sometimes in large railway and power systems, several plants, separated by a

distance, are required to run in parallel to preserve a fairly uniform line voltage. In such cases the resistance of the line acts as a sort of a cushion between the several stations. In Figure 2 we have two dynamos, A and B, feeding a trolley wire. The load C in the form of a car is a movable one. That dynamo will supply most of the load, which is the nearest, or which has the lesser resistance between it and the car. In this way the losses in the transmission system are reduced considerably. A short circuit some distance away from the power house may not load the dynamo beyond its full load capacity, if the line resistance is high enough. To take an illustrative example: Suppose the line resistance be one-half an ohm, then the current at 500 volts will be 1,000 amperes, or the capacity of a 500 kilowatt dynamo. From this it can be seen that there can be quite a large variation in voltage between stations having a high line resistance. The higher the line resistance the larger the possible variation. The only effect that this difference in voltage has is to remove the load to a large extent to that station that supplies the higher voltage to the point where the load is. This cushioning effect with high line resistance is not to be recommended on account of the large waste of energy.

The shunt dynamo may also be run in parallel by using some form of automatic device to divide the load properly between them; but such devices, like all others of the same character, make one skeptical as to their successful operation.

This brings us to the point of discussing the relative merits of shunt, compound, and over-compound dynamos. The shunt dynamo decreases in terminal voltage as the load increases. It must be compensated for by varying the field rheostat. The compound dynamo has an additional coil on the field that is connected in series with the armature.

By varying the number of turns in this coil, the voltage may be kept constant from no load to full load, or it can be made to rise a certain per cent. above no load voltage. This latter is called "over-compound wound." With over-compound wound dynamos the difficulty of running them in parallel without an equalizer is very much enhanced, since, when one machine loses some load it drops in voltage, whereas the machine that takes more load will increase in voltage. This state of affairs will continue until the load is removed, and will finally motor it. When this occurs the main switch should be pulled in order to avoid accident. When two or more machines are compounded to the same extent by using the equalizer to be described, they will work as satisfactorily as can be desired.

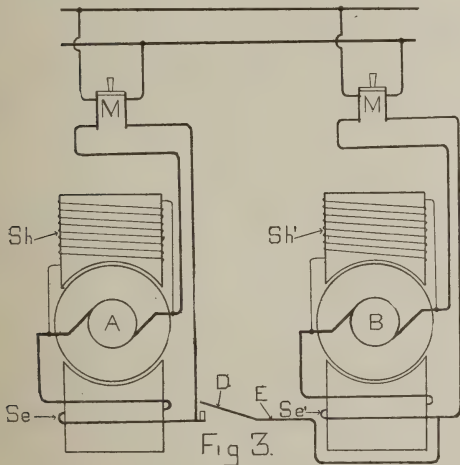

Figure 3 shows the connections of two compound wound dynamos. A and B N S and N'S' are the poles, Sh and Sh' are the shunt coils, Se and Se' are the series coils, and M and M' are the main switches of the dynamos A and B respectively. E is the equalizer cable connecting two similar points on the dynamos as shown. A switch D is connected in series with the equalizer.

Suppose A is running and is carrying a load; some of the current is shunted

and passes around the coil Sh. The series coil is connected in series with the armature. As the load increased, more current is taken from the armature, and consequently more current goes through the coil Se. This increases the ampere-turns in coil Se, and if the iron is not already saturated, will produce an increase in voltage.

When the load becomes too great for A and we wish to have B in parallel with it, we bring the voltage of B to that of A and then close the equalizer switch D. This puts the series coils of the two machines in parallel as soon as the main switch is closed. If both series coils are of equal resistance, then both will carry equal currents provided the equalizer has no resistance. The voltage of A will then drop a little, due to the decrease of current in Se, and slightly increase the voltage of B, due to the current now flowing in Se'. If the machines are of equal capacity they should take equal loads. This they will do after the machines have been properly installed, as the equalizer will not get out of adjustment unless the connections are loose or the cable breaks.

Should it now be required to transfer the entire load from A to B after they are in parallel, the rheostat of B is moved so as to increase the voltage and that of A is moved in the opposite direction simultaneously. This will cause the load to shift from one machine to the other, and, when the ammeter of A indicates little or no current, the main switch can be opened and the machine stopped. When this is properly done there will be no change in the line voltage. When both are running and it is desired to raise or lower the voltage, both rheostats are moved up or down either to increase or decrease the voltage.

If one machine should take a larger load for any reason outside of varying the shunt resistance or speed there will

be a difference in the current carried by the series coils Se and Se'. As both are of the same resistance, then, the coil having the larger current, being in parallel with the other, will naturally divide up the current equally between them, as can readily be seen from Ohm's law. As the larger loaded machine has some of its current diverted to the other machine, then it will drop slightly in voltage and increase that of the other. This equalizing tendency exists on account of the wire connecting the series coils in

ing a series coil resistance of .01 ohm, one double the capacity should have one-half of it, or .005 ohm resistance. This however, applies only to machines of the same type or characteristics.

If the machines are not of the proportional series coil resistances, then some must be added to the one which is deficient. Even machines of the same type are not in direct proportion with respect to resistances, and it is, therefore, better to adjust the equalizers under the conditions they must work.

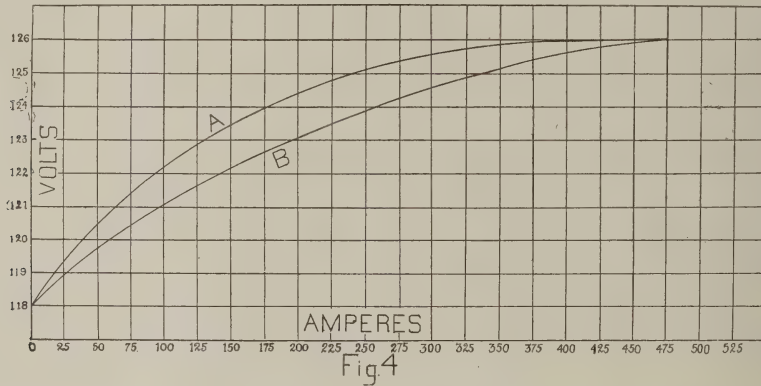

Fig. 4

parallel, and should this wire be removed then no current can be diverted from one coil to the other and no equalizing tendency will remain.

Conditions are considerably improved by the fact that when one coil gains some current the other loses an equal amount, and thus only a small amount of current is required to produce an effect.

When the machines are of different capacities then the load should be distributed in proportion to their capacity. For instance: A 25-kilowatt and a 50-kilowatt dynamo are operating in parallel. Should 75 amperes be thrown on the bus-bars, then the larger machine should take 50 amperes and the smaller should take the remaining 25 amperes.

In order that this should be so the resistances of the series coils should be inversely proportional to the capacity of the machines. That is, a dynamo hav-

ing a series coil resistance of .01 ohm, one double the capacity should have one-half of it, or .005 ohm resistance. This however, applies only to machines of the same type or characteristics.

If the machines are not of the proportional series coil resistances, then some must be added to the one which is deficient. Even machines of the same type are not in direct proportion with respect to resistances, and it is, therefore, better to adjust the equalizers under the conditions they must work.

It is known that different types of machines do not equalize properly at all stages of the load. Fig. 4 shows the over-compounding characteristics of two machines. Measurements on the horizontal line represent volts measured at the terminals of the machines. The vertical lines represent different currents taken from the armature. The terminal voltage is read at the different loads and plotted. A curve is drawn through the points so obtained. Curves like A and B will be the result. If the machines are adjusted to equalize properly at or near full load, then at half load the machine having A for its characteristic will take the larger load. This difficulty can easily be approximated by not getting quite perfect equalization, and in many modern machines can be left entirely out of consideration.

The current carried by the equalizer varies considerably. While being parallelled, if both machines are of equal capacity, it will carry one-half of the main-line current. When the machines are running with a steady load no current flows in the equalizer, and, at other times, when the load is variable, it carries a very small amount of current—depending upon how much the machines are out on their characteristics.

In practice the size of the equalizer is generally made equal to that of the main cables, and this has been found sufficient for all practical purposes. As has already been stated, the equalizer should have as little resistance as possible, so care should be exercised to make all connections as though they were carrying current all the time.

In Fig. 3 the dynamos are shown to have a separate equalizer switch. This is sometimes mounted on the switch-

board and sometimes on the dynamos themselves.

This equalizer may also be connected to one leg of a triple-pole switch, using the two other blades for the dynamo leads.

The equalizer is often made in a permanent form by connecting the proper points directly with a cable. This reduces the cost by dispensing with the switches, and the cable can be made short, thus decreasing the resistance.

Aside from the advantages of proper proportioning of the load for all machines, the equalizer has the advantage of exciting the field coil of the incoming dynamo in the proper direction. Should one of them be accidentally reversed a short-circuit will be formed by closing the main switch, which may destroy both dynamo and engine. This difficulty is increased on engines for electrical purposes, as they generally have high rotational speeds and massive flywheels.

Bion J. Arnold's Report on the Engineering and Operating Features of the City of Chicago's Transportation Problem

THE well known consulting engineer of Chicago, Mr. Bion J. Arnold, acting as consulting engineer to the "Committee on Local Transportation of the Chicago City Council," has added greatly to his reputation by the very complete and exhaustive report and review of the engineering, commercial and operating features of the complicated transportation problem in the city of Chicago. This publication, following within a few months,

as it does, Mr. Arnold's report to the directors of the New York Central Railroad on the electrical equipment of their system in New York, a condensed account of which was read by Mr. Arnold before the Nineteenth Annual Convention of the American Institute of Electrical Engineers, at Great Barrington, Mass., June last combine to bring Mr. Arnold before the electric railway interests as one of our most able electrical consulting engineers in his broad and

comprehensive grasp of the large and very intricate problems arising in the consideration of these matters.

Mr. Arnold does not promote any new or experimental features in his consideration of the problems arising from the present inadequate and complicated transportation situation in Chicago, but carefully reviews the present situation, and then presents on a sound engineering and operative basis the various solutions of the problem on well proved plans to improve and make adequate the transportation facilities of the people of Chicago, which problem is only overshadowed in its magnitude by that of Greater New York, on this continent.

Mr. Arnold has wisely, in taking up such a problem, secured the able assistance and co-operation of such well known men in transportation matters as Messrs. Charles V. Weston, C. E.; Augustus W. Wright, C. E.; Oren Root, Jr., and George C. Sikes.

The full report was submitted to the committee by Mr. Arnold on December 30, 1902, and in printed form comprises a book of 300 pages, with 15 plates and 14 maps, and 10 appendices.

The text of the Report is divided as follows:

First, we have an account of the ordinance authorizing the engagement of Mr. Arnold and the payment to him of the very moderate sum of ten thousand dollars for his services, and all expenses and assistance, in the presentation of the complete Report.

Accompanying Mr. Arnold's report are the following recommendations and conclusions, which we give in full:

I—The One-City-One-Fare Idea

Chicago, with respect to transportation as well as other things, should be regarded as one city, not three. Divisional lines ought to be obliterated as far

as possible. A street car passenger should be carried over the most direct route between any two points within the city limits for a single fare. Complete unification of ownership and management is the best plan for realizing the one-city-one-fare idea. The same end can be accomplished, however, but in a less satisfactory manner, under divisional ownership, by a plan of through routing of cars, joint use of tracks and interchangeable transfers. To a still less satisfactory degree the same end can be accomplished by the interchange of transfers between companies without joint use of tracks.

II—The Through-Route Principle

Routes through the business district ought to be substituted for downtown terminals wherever possible. Outside the business district, too, the best results would follow from connecting together the detached lines now found on several streets, and operating cars over such lines from end to end on the through-route principle.

III—Subways

A system of subways should be, and eventually must be, built to accommodate the street car traffic of Chicago and relieve the street surface congestion in the business districts. Galleries should be provided in connection with such subways for the accommodation of present and future underground utilities. Two subway plans are outlined in the report. One plan referred to as the subway plan No. 1, shown on map No. 11, calls for three north and south subways, from Fourteenth street on the south to Indiana street on the north, and two subways entering the business district from the West Side, utilizing the present Van Buren and Washington street tunnels and looping back to Clark street. This is a system of high level subways

throughout, with no dips. Its estimated cost is \$16,000,000. The other subway plan, known as plan No. 2, shown on map No. 5, calls for practically the same north and south high level subways in combination with three or more low level subways from the West Side, passing under the north and south subways and reaching Michigan avenue, and should future developments warrant, under Lake Front Park as far as it may be extended. The low level subways would require the use of elevators. The estimated cost of subways built according to this plan is \$20,000,000. Plan No. 2 is recommended as best for the city from an engineering and transportation point of view, but in case this plan is deemed inadvisable for business or other reasons, a system of single decked, high level subways, as outlined in plan No. 1, can be constructed, which will, to a large extent, accomplish the results. No subway should be built in such a manner as to preclude the operation of cars through them on the through-route principle. Under either of the plans as outlined, the whole system of subways need not necessarily be constructed at once. One or more of the subways could be built at a time and utilized separately, but with a view to their ultimately forming a part of a comprehensive system. The subway plans as submitted do not necessarily call for the removal of all tracks from the street surface in the business district, and subway plan No. 1 necessitates some surface loops. Under either plan there could be a street surface system connecting the depots and designed to accommodate short haul traffic in the business district. Under plan No. 2 there could also be a low level subway system for connecting all depots, and by using it in connection with this subway all tracks could be kept off from the surface of the streets

in the business district for some years to come.

IV—The Present River Tunnels

It is inadvisable to attempt to lower the present river tunnels, but . . . at the same time in the interest of navigation, the tops of the tunnels ought to be promptly removed, leaving the lower parts of one or perhaps two of the tunnels for utilization later as parts of a future subway system.

V—Plan for a Unified Combined Surface and Subway Street Railway System

A plan is presented for a new, reorganized and unified combined surface and subway street railway system, comprising the lines of the City Railway Company, the Union Traction Company, the Chicago General Railway Company, and the Chicago Consolidated Traction Company within the city limits, and new lines necessary to properly connect the now disconnected parts of the system. The total single track mileage of this system as outlined would be about 745 miles, and its estimated cost, if constructed new, with everything first class throughout, but exclusive of subways, would be \$70,000,000. Adding \$20,000,000, the cost of the subways constructed according to plan No. 2, would make the total cost of the new system complete, \$90,000,000. With subway plan No. 1, instead of No. 2, the total cost of the new unified system would be \$85,800,000.

VI—Plans for Immediate Improvement of Terminals and Service

Plans are presented for the rerouting of surface terminals in the business district, (1) under the present divisional ownership and operation, (2) under the joint use of tracks in the business district under the divisional ownership, and (3) under unified ownership and man-

agement. Immediate improvement of Chicago's local transportation facilities may be effected by substituted electric for cable power and routing cars according to any of the plans outlined, all cars from the west and north sides to enter the business district over bridges until such time as subways shall be constructed.

VII—Electric Underground Conduit System

The operation of cars in Chicago by the electric underground conduit system is practicable and feasible. Overhead trolley construction should be prohibited within the area bounded by Twelfth street on the south and the river on the north and west. Outside of the district named the objections to the overhead trolley are aesthetic in nature, and it is for the city authorities to say—after a balancing of financial against aesthetic considerations—how much, if any, underground conduit construction should be required. The cost per mile of single track (track alone, including feeders) of electric conduit road construction would average \$81,300 for a system covering the city at large, but exclusive of the cost of power, rolling stock and paving. Conduit construction, outside of the business district, should not exceed \$70,000 per mile, but within the business district the cost would be about \$100,000 per mile, due to the numerous curves, large amount of special work required and the extra cost of labor, due to the congestion within the district in which the work must be prosecuted. To either of the above figures should be added the cost of paving, as follows: Brick, \$12,650; asphalt, \$12,880; dressed granite, \$18,400. Overhead trolley road construction would cost \$28,000 per mile of single track, using the same weight of rail. It would cost nearly as much to convert the Chicago cable roads into electric conduit roads as to build new electric conduit roads.

VIII—Grooved Rails

A grooved girder type of rail of special design is recommended for well paved streets upon which cars operate often enough to properly clear the groove of dirt and ice. On outlying streets and on poorly paved and poorly maintained streets the girder type of rail should be maintained as best for team traffic and the railway companies.

IX—Electrolysis

The destruction of underground utilities from electrolysis is now well in hand by the city, and if the present ordinance governing the subject is enforced, no serious difficulties may be anticipated from this source, and when the underground conduit system is adopted, there should be no further injury from electrolysis in the area served by the conduit system, because this system uses a complete metallic circuit.

X—The Financial Aspect of the One-City-One-Fare Plan

A unified company could afford to conduct the transportation business of Chicago on the basis of a single fare for a continuous ride anywhere within the city limits. The present divisional companies, by the interchange of transfers, could afford to do the same thing, provided they were properly protected against the fraudulent use of transfers, but it would be at a somewhat greater cost to themselves, and with greater inconvenience to passengers, than would be the case under unified management.

XI—Growth of Population and Traffic in the Past and Estimates as to the Future Increase of Street Car Traffic

The population of Chicago has increased since its incorporation, in 1837, to 1902 at the rate of 8.6 per cent. per year compounded, and is now increasing at the rate of 7.7 per cent. per year.

For the nine years from 1892 to 1901, inclusive, the number of revenue passengers carried by the Chicago surface and elevated lines combined has increased at the rate of 5 per cent. per annum compounded. The increase for the surface lines during the same period has been at the rate of 1.5 per cent. per year compounded. The increase for the combined surface and elevated lines from 1894 to 1901, inclusive, a period of seven years, has been at the rate of 6.3 per cent. per year compounded. The increase for the surface lines alone during the same period has been at the rate of 3.9 per cent. per year compounded, and the increase for the elevated lines alone has been, for the same period, at the rate of 26 per cent. per year compounded. The population of Chicago has increased more rapidly than that of any city in the world, but it is improbable that this rate of increase should continue indefinitely. Figures and curves are presented showing the past growth of Chicago as compared with other cities, also the future results if present rates of increase should be maintained, but as this is improbable, curves are shown representing the increase in population and gross receipts that may reasonably be expected for the combined surface and elevated railways during the next fifty years.

XII—Estimated Cost of Reproduction and Present Value of Existing Plants

The cost to reproduce the following properties complete, with new construction and equipment throughout, would be: Chicago City Railway Company, about \$17,200,000; Chicago Union Traction Company (not including the Consolidated Traction Company), about \$22,200,000. The actual present value of the physical properties for electric railway purposes of the following companies, taking into consideration the obso-

lete equipment and construction, which must be discarded, but not taking into account any franchise rights or earning capacity of the properties, is estimated as follows: Chicago City Railway Company, about \$12,000,000; Chicago Union Traction Company (not including Consolidated Traction Company), about \$15,000,000.

XIII—Need for Regulation of Team Traffic

At the present time team traffic interferes with street cars to an unwarrantable extent. A reasonable regulation of team traffic is essential to the improvement of street car service.

XIV—The Union Elevated Loop Problem

The junction points are the ultimate limiting capacity of the Union Elevated Loop. At the present time, however, the platform stations are the limiting factor. The first and simplest way to increase the capacity of the loop is to lengthen the station platforms so that two trains can load and unload at a station at the same time. When the capacity of the junction points is reached, added facilities can be provided by building stub-end terminals just outside the loop could be increased by dividing the loop. The terminal capacity of the present loop into four smaller loops, but presumably there would be public objection to such a plan, because it would involve encumbering more downtown streets with elevated structures, and it is, therefore, not recommended. The ideal solution of the elevated loop problem would be to utilize the loop structure as sections of through routes between the different sections of the city.

Consideration was given to the complete rebuilding of the antiquated cable lines and the doing away with the train cable car system now in use there; a plan for consolidating the different sys-

tems and rearrangement of their terminal facilities in the congested central business district of the city, and attempting to better the inadequate service now existing; the introduction of a universal transfer system and a one-fare plan. All of these problems are brought forward at this time owing to the question being up before the City Council as to what is the best solution for the public's and city's interest of the transportation problem, and what shall be done about renewing or extending the street railway franchises which are about expiring, and, if renewed, what shall be the conditions imposed in order to secure the best service and future growth of the city or shall the city purchase the existing lines. The controlling interests in the street railway properties, we believe, are meeting the matter in a broad and comprehensive manner, and offer to agree to the plans proposed for a betterment of the

system and expend whatever is necessary to accomplish it, providing they are granted reasonable and fair extensions to their franchises. Mr. Arnold has wisely not attempted to say what should be done, feeling that was outside his province, but has shown how and in what manner the different plans can be carried out, and indicated the results secured from each plan proposed. We feel sure that, when the problem is settled, the city and street railway interests will adopt one of the plans indicated and outlined in Mr. Arnold's report, which is well worthy of the most careful consideration and study by the student of the transportation problem in our large cities, and is the fullest and ablest presentation of the matter which has come to public view, and a copy of it should have a place in the history of the street railway engineer, owner and operator.

Our Enormous Street Railway Growth

IN the report of the New York State Railroad Commission the most notable figures are those showing the development of the street railways during the last ten years. A growth in the mileage of 150 per cent. in this comparatively brief period is indeed remarkable, as is also the fact that the gross earnings nearly doubled in the same time.

These figures show that the street railways of the various cities of the State have done very much better than keeping pace with the growth of population, and they should modify some of the harsh criticism bestowed on the lines. The increase from 739,000 miles in 1892 to 1,746,000 miles in 1902 proves that

managers of the companies have been actually doing wonders in the matter of providing additional transit facilities.

That there has been no niggardliness in the equipment and operation of the roads is shown by the fact that, while the number of passengers carried increased in about the same ratio as the miles of track, the profits did not. The value of the property of the companies was trebled in ten years, and the stock and bonded indebtedness likewise, clearly indicating that every dollar that was raised was put into improvements, and not frittered away in experiments, as has occasionally been ignorantly charged.—*Wall Street Summary.*

The Advancement of the Motor Cycle in Great Britain

ALTHOUGH the motor cycle has been in use in Great Britain for but a little more than two years, it is fast becoming a most important branch of the automobile business. There are already several thousand in use in the United Kingdom, and their appearance in London and on the country roads is now so common as to no longer excite comment.

While there is, popularly speaking, a boom in motor cycling, and there are over a score of machines on the market, the majority are of French and Belgian make. The number advertised as English machines with English names are either imported outright or consist of continental motors built into English frames by local companies.

Of the machines that are really English built throughout, the Singer, the Enfield, and the Humber are the product of big factories that have previously made a reputation in cycle business.

America is already represented by three standard machines, the Mitchell, the Orient, and the Royal, all comparing favorably with the best English and continental makes.

Belt driven machines are still vastly in the majority, despite certain obvious disadvantages of the system; though, curiously enough, among the high-grade English machines the Singer is gear driven, and the Humber has a chain drive with a spring clutch for taking up the starting strain of the motor. The high tension electric ignition system, with coils and accumulators, is almost universal, though the Singer has an elec-

tro-magnetic ignition device which works very satisfactorily.

Excessive weight is the most objectionable feature of the prevailing type of machine. Those most commonly seen average 100 pounds. One of the standard road machines weighs 120 pounds, while the track racers, though they hardly deserve to be classed with the popular motor cycle, reach as much as 250 or 300 pounds. The lightest practical road machine is the Clement-Garrard, a French product. The motor set complete weighs only 21 pounds, and is built into an English frame by a company in Birmingham, the machine scaling 65 pounds, all on.

The principal difference between the English and American machines at present is that the English are belt driven instead of chain driven or direct geared. The motor is frequently merely clamped into the diamond frame of an ordinary bicycle instead of being built into a special frame. It is only fair to say, however, that a number of special frames are now being designed with a special view to standing up under the increased weight and vibration of the motor. Accumulators are favored as against dry batteries or electro-magnetic ignition. The standard horse power up to date has been 1 1-2, but new machines are being constantly turned out with engines of from 1 3-4 to 2 1-2 horse power, to meet the demand for greater hill-climbing power. It is generally conceded that the very high-powered wheels are wasteful of fuel and subject to excessive vibration on the level, and that the ideal machine will

be one with a light and comparatively low-powered motor, but with a two-speed gear that will insure good hill-climbing power.

In spite of the English speed limit of 12 miles per hour, the English motor cyclist demands a machine capable of a good 20 miles on the level, with ability to keep it up without danger of overheating.

In its present stage of development, the motor cycle is undergoing constant change and improvement. There is no machine on the market that can claim to combine all the desirable features. But there are several points that might well be kept in view by a maker who wants to produce an ideal wheel. Weight should be maintained as low as is consistent with effective working. A 50-pound wheel at the present juncture would command practically its own price. A thoroughly effective chain or gear drive, obviating the constant belt troubles that now worry the rider, would soon make its way, in spite of the popular idea fostered by many makers that the belt drive is the only effective and practical form of transmission. A simple two-speed gear, giving 20 miles an hour on the level, with the ability to take grades of one in seven without pedal assistance, is in great demand and is not forthcoming. A light weight but reliable form of electromagnetic ignition would win its way against the now popular accumulator system. The trouble with the present magneto systems is that they will not endure the constant vibration. The petrol capacity of the machine should be at least 100 miles. Single lever control of the gas and electric sparking devices has been tried and proved both effective and popular. Antivibration seat-posts and handle bars are absolutely essential to comfort, and while there are good devices of this sort on the market, I believe there is at present no machine

turned out from the factory with them. Another feature strongly demanded by riders, and not yet supplied, is either a comfortable spring foot rest or a swing-back pedal that will do away with the cramped position incident to keeping the feet on fixed pedals during a long ride.

The accompanying illustrations will give an idea of the types of machines in most common use here. It may be remarked, however, that the Minerva, the Werner, and the Clement-Garrard, all foreign machines, are more numerous than all the other makes combined. Finally, prompt delivery is of great importance, as there are but few of the machines on the market that can be supplied by the makers from stock.

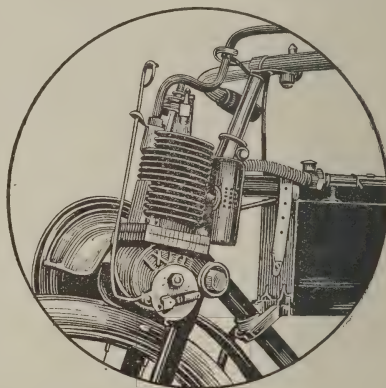

The Ixion.

The Ixion two-stroke motor, weighing 18 pounds, claims to develop 1 1-2 horse power, and works with friction roller on front tire. It is a French device, but an English company is now fitting it to ordinary road bicycles. Price, motor set, \$76.64; with cycle complete, \$133.83.

The Clement-Garrard is a French motor, weighing only 21 pounds, built into an English frame by the Garrard Manufacturing Company, of Birmingham. It holds a record of 100 miles on three pints of petrol and is the highest practical ma-

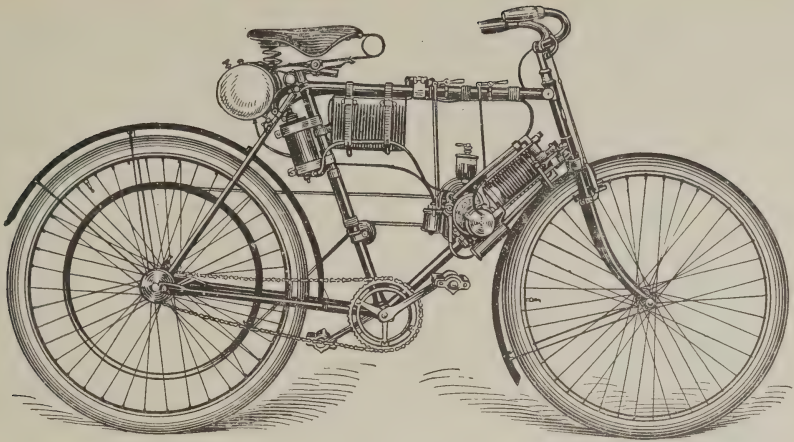

The Clement-Garrard.

chine now on the English market. Weight complete, 65 pounds. It is belt driven, with high tension electric ignition, and may be taken as one of the best types of English roadster. The company is putting out a chain driven machine for next season.

The Werner French motor holds a prominent place at present in the English trade. The motors are sometimes imported and built into English frames, though the larger number of these cycles

workmanship is excellent, and their reliability has won them their high rank in the estimation of English cyclists.

The Brown is a type of imported Belgian motor mounted in English factories. The motor is less than 2 horse power.

The Holden is a peculiar looking English machine manufactured by the Motor Traction Company, Limited, Walnut Tree Walk, Kennington, London, S. E. It has no belt, chain, or pedals—the four

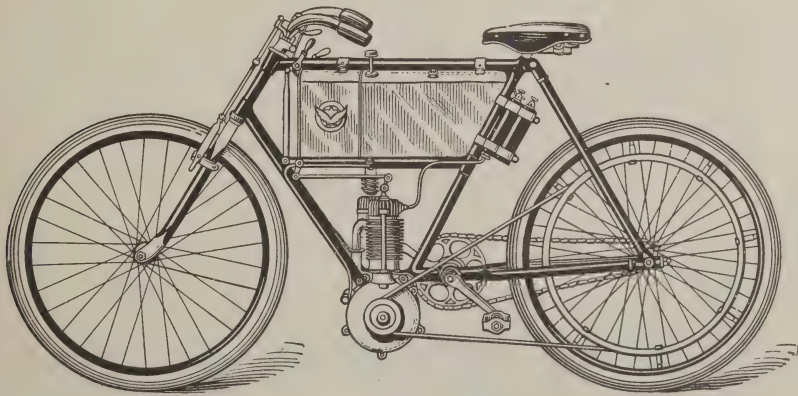

The Werner.

are French built throughout. They are all belt driven with the usual high tension ignition, and while there is no striking mechanical feature about them, their

cylinders driving direct to the small rear wheel. One coil and trembler actuates them all. The engine is water jacketed, 3 horse power, and can be controlled by

a single lever from walking pace to 30 miles per hour. It has no fly wheels or crank cases. The lubrication is automatic, and petrol can be carried for 150 miles. As it is a comparatively new

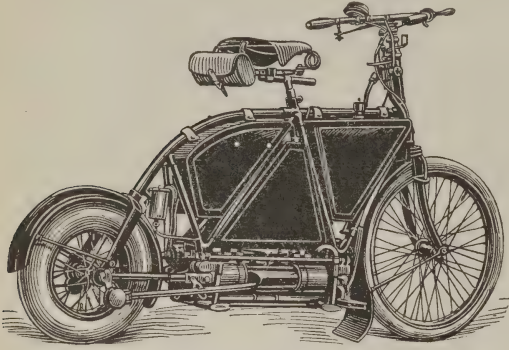

The Holden.

machine, it is impossible to say just how its radical features will compare in actual work with the standard type of small combustion motor.

The Single-Motor Tandem is a strictly English machine. It is peculiar in having the whole of the motor mechanism inclosed in the driving wheel. The bicycle is built on the same principle, but drives from the rear wheel. The motor and petrol tank ride on the axle, to which the motor is geared direct. The ignition is magneto-electric, all the necessary levers being controlled from the handle bar. The bicycle motor is of 2 and 2 1-2 horse power, and the machines are extremely good hill climbers. A spare petrol tank can be carried in the frame, giving a capacity of nearly 200 miles. The price of the bicycle is \$340.65, and in spite of its high cost it seems to be a popular machine, indicating that the English rider is able and willing to pay well for a satisfactory wheel.

Other popular machines are:



The Single-Motor Tandem.

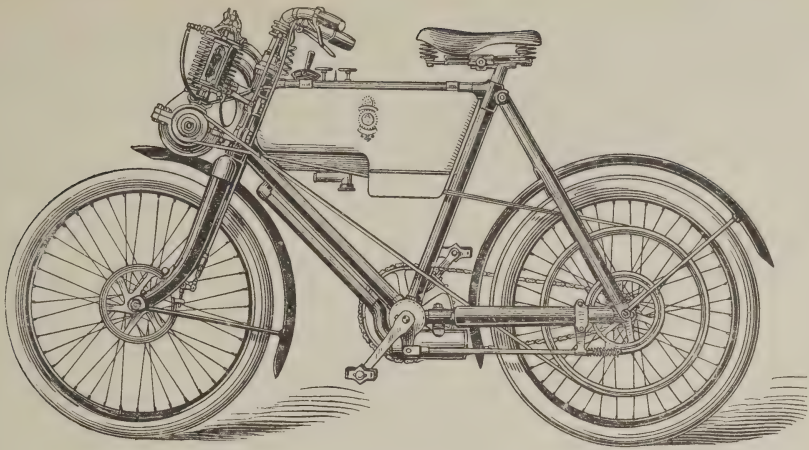

The Royal Enfield.

The Rex (English), 2 horse power motor and petrol tank carried inside frame; belt drive; front fork strengthened; petrol capacity, 100 miles; price, \$245.28; weight, 100 pounds.

The Minerva, a typical Belgian motor, which is imported and built into all sorts of English frames; made in 1 1-2 and 2 horse power; uses belt drive and coil and accumulator ignition.

frame, magnetic ignition; petrol capacity, 150 miles.

The Royal Enfield is another type of English machine, manufactured by the Enfield Cycle Company, Redditch, England. The 1 3-4 horse power motor is mounted on the steering head, giving an extra long belt drive. It is understood, however, that the company's next machine will carry the engine inside the

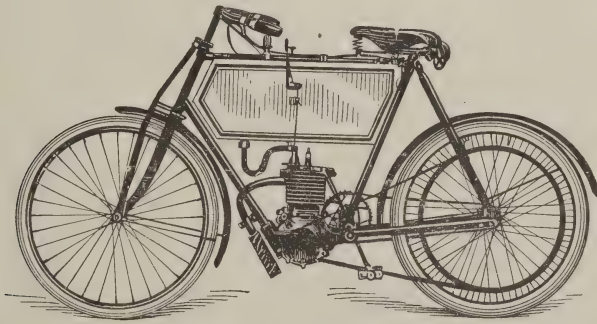

The Rex.

The Royal Sovereign, an English machine of conventional type; 1 1-2 horse power motor and petrol tank carried inside the frame; drives from a twisted rawhide belt; maximum speed, 30 miles per hour; price, \$168.63.

The Clyde motor bicycle; English made; 2 horse power engine built into

frame. Petrol tank, coil, accumulators, and lubricating reservoir are all carried in the large metal case inside the diamond. Price, \$255.50. The same company makes a 2 3-4 horse power tricycle at \$383.25 and a 3 1-2 horse power quad at \$613.20. The higher powered engines are water cooled.

Lighting and Power Plans for the St. Louis World's Fair

THE sources of energy will include

1. A plant installed in the Machinery Building of 8,000 kilowatts' capacity, with the necessary boilers and engines.

2. Seven thousand kilowatts will be rented from an outside source, and this will be delivered at the Exposition barrier and thence brought to the general switchboards in the Machinery Building.

3. The exhibit plant designed to furnish current for demonstrating electrical and machinery practices, which will include steam units of the reciprocating and turbine types, as well as large gas engines, each with its electrical and boiler complement; it is estimated that this plant will be of at least 14,000 kilowatts' capacity, making a grand total of 31,000 kilowatts.

Rotaries and transformers will be established in various substations, capable of transforming from 6,600 volts alternating to whatever pressure may be required.

The architectural scheme of the buildings will be so far preserved at night by incandescent lamps as to convey a most effective impression of their extent and general outlines. It is believed that incandescent lamps lend themselves to this end more harmoniously than arc light, and the effect from a distance will be more striking than if arcs were used. The center of the Exposition territory will be occupied by the "Cascades," made up of architectural, sculptural and hydraulic features of ornate design. At night this territory will be treated with

combinations of lightings of most spectacular design, in such a way as to obliterate the idea of mere "light-trimming," and to give to the retina the idea of light substance, if such a thing can be conceived. The multi-colored effects may perhaps be appreciated, for example, in the combination which will give to the entire hillside an emerald color, while the water of the cascades will take on the phosphorescent hue of the Cooper-Hewitt lamp, and, in turn, when the entire territory appears wholly incandescent, the waters of the cascade will appear as molten silver.

These and like changes are not to be brought about in such a way as to suggest a mechanical agency of an automatic nature, but the gradual dissolving of one effect into another will be accomplished according to a prearranged programme, and will be rendered possible by the use of the Cooper-Hewitt lamps—now become of world-wide fame—because of the peculiar quality and "feeling" they impart to water.

The pumping machinery will be located beneath one of the side cascades, and will have a capacity sufficient to raise 90,000 G. P. M. to a height of about 154'.

Induction motors of 2,000 horse power of special design for operating on 25 cycle, three-phase current, will operate the pumps.

All in all, the electrical equipment of the St. Louis World's Fair will be of vast and absorbing interest to the profession.

The Proposed Freezing Process for the Pennsylvania Tunnels

THE invitation of the Commission of Engineers appointed by the officers of the Pennsylvania Railroad early in 1902 to engineers throughout the world to assist in the proposing and consideration of plans for obviating the difficulties in the way of the stupendous task before them — of tunnelling the North and East Rivers — was one well calculated to bring forth responses from men eminent in the profession, and which, in point of fact, did bring forth abundant fruit.

The scheme contemplates two parallel single-track tunnels between the Jersey shore terminals, under the Hudson River, Manhattan Island and the East River to a point connecting with the lines of the Long Island Railroad on Long Island; also a supplementary pair of tunnels for local trains between the Long Island Railroad lines, and a central station on the line of the main tunnel in New York City.

Mr. Charles SooySmith, member Am. Soc. C. E., submitted a plan which has for its particular feature a process whereby the treacherous silt or sediment through which at various points the tunnel must be built, will be frozen, thus rendering excavation through this material safe and easy.

In a most instructive article in the "Engineering News," Mr. SooySmith sets forth an account of the methods and apparatus to be used. After adverting to the difficulties in the way of locating a tunnel in the silt of the river bottom because of the fact that the tunnel struc-

ture would generally be lighter than the material it displaces, he points out the consequent necessity for varying the weight and load from traffic, and the vibratory effect upon the silt from moving trains, by transmitting such vibrations over the larger mass of silt, so that they will be dissipated and absorbed.

Mr. SooySmith then advocates the rigid pile foundation, with an outline of the work of driving the piles through tubes by means of a Nasmyth hammer worked by compressed air. We quote directly from Mr. SooySmith's account of the methods of construction:

"The method suggested for the construction of the tunnel itself is an application of the well-known freezing process, by which many deep and difficult excavations have been made for shafts in Europe and at least one in this country—a shaft at the Chapin Iron Mine at Iron Mountain, Mich., where a cylinder of water-bearing strata 54 ft. in diameter, and extending 100 ft. below water level, was first frozen and the shaft then excavated through the material thus solidified. This work was done very quickly and successfully, and at the time engineers expected it would be followed by a very considerable use of the process. It has, indeed, been frequently used in Europe, but there have been few places in the United States where the difficulties and expense of sinking a single shaft justified the outlay for installing a refrigeration plant.

"For shaft work, it is usual to sink vertical pipes arranged in a circle around

the site of the shaft. These pipes are closed at the bottom, and each contains a smaller pipe open at the bottom. Brine, cooled by an ice machine, is circulated through these pipes until a frozen wall is made, shutting off water and sand, and permitting the excavation and shaft work to be readily done within the protection of this frozen cofferdam.

"To apply the freezing process to the construction of subaqueous tunnels, there has seemed the almost unsurmountable difficulty of reaching the earth to be frozen by a circulating medium with which to accomplish the freezing, and it is to provide a way to attain this end that the present designs have been made.

"In constructing subaqueous tunnels by compressed air, the difficulties and large cost occur chiefly because of the difference of hydrostatic head at the top and bottom of the heading and from the size of the shield. When this difference is small, as in a tunnel but 6 or 7 ft. in diameter, the tunnel can be excavated through the most difficult materials with comparatively small expense. The plan contemplates, therefore, that a small pilot tunnel 6 or 7 ft. in diameter be built on the center line of the proposed main tunnel, and that this be used as a refrigeration chamber, from which to freeze the material surrounding this small tunnel. This may be accomplished by maintaining a temperature below 0 degrees Fahrenheit in this pilot tunnel, just as is now done in cold storage plants where, in some cases, brine is circulated through pipes located in the cold chambers and in some instances air cooled in another room is blown in and circulated. The pilot tunnel may be temporarily lined with metal plates and brine may be circulated through pipes laid against this, leaving the center unobstructed, so that the freezing may follow closely the excavation of the pilot tunnel; or, when

the pilot is first completed, its lining may be made tight and the brine circulated through the body of the small tunnel itself. When it is desired to extend the pilot while freezing is in progress from it, the walls will be made annular so that access can be had through the center.

"Where a double-track tunnel is to be constructed requiring a very large excavation, radial pipes may be pushed out in sections at intervals from the pilot tunnels and the brine circulated through these. In the work done at Iron Mountain, the material was frozen to a distance of 9 ft. in 72 days from pipes 8 ins. in diameter, with brine at zero temperature. Thus the material may be solidified to a sufficient distance to enable the full-sized tunnel to be excavated at one time, still leaving an ample protection of frozen material outside of the excavation.

"Another plan of procedure not necessitating the use of radial pipes would be to begin excavation when the freezing had extended 4 or 5 ft. from the pilot tunnel, and enlarge the excavation a foot or two at a time by successive operations as the freezing proceeds outwardly, doing the freezing by a circulation of cold air.

"Large refrigeration plants are now in use in New York and other cities in which the refrigeration service is carried several blocks from the producing plant.

"By the methods outlined above a cylinder of the material in the bed of the river can be readily solidified, and at a relatively small cost, accurately ascertainable beforehand. From the records of the work done at Iron Mountain, and tests made on silt dredged from the bottom of the Hudson, the speed at which the freezing can be done, the number of thermal units required to freeze a given amount and the loss by cooling outside the mass frozen, are known. Tests made on the frozen silt show its strength to be equal to that of good concrete. Hence,

while the material would be solidified to a distance of several feet outside the space to be excavated, the strength is such that 2 or 3 feet of frozen wall would suffice to prevent collapse.

"In excavating for the tunnel, the methods now common in the mining of frozen material in the Klondike could be employed: Also some of the appliances used in the mining of coal would be well adapted.

"Pilot tunnels can be built under the Hudson at about the rate and cost of those that have been run out under Lake Michigan and Lake Erie at many points for water-works intakes. These have been built in many instances from 10 to 15 ft. per day, and at a cost of less than \$20 per ft. As bearing on the possible cost of freezing the silt, which does not contain 40 per cent. in volume of water, it may be stated that plants in operation in New York City are producing ice at an actual cost of less than \$1 per cubic yard. As bearing on the probable cost of excavating the frozen material, it may be stated that the cost of mining coal and bringing it to the surface is generally less than \$1 per cubic yard.

"In answer to the question whether the material will not thaw quickly after the excavation is made, it may be observed that the temperature of the frozen mass will be considerably lower than the freezing point and that the surrounding earth will conduct heat but slowly. The loss of cold toward the interior excavation will also be slow, as the air will be changed only as required for ventilation. Thus there will be ample time for constructing the permanent work, which could, however, follow close to the finished excavation.

"With reference to the feasibility of building the tunnel structure of masonry against the frozen earth, it may be said that freezing does not seriously, if at all, injure Portland cement, and it will be

practicable to keep the temperature of the masonry above the freezing point for a sufficient time to permit the cement to set, and at the same time maintain the frozen wall outside. It is a fact that in the shafts sunk by the freezing process, but little trouble from thawing, or

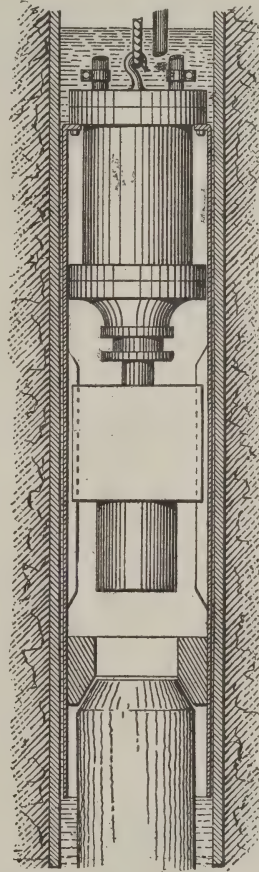

Fig. 1

in building the lining, has been experienced, and the frozen wall about the excavation has been known to remain frozen for months after the completion of the work.

"The programme suggested thus contemplates, first, providing a continuous foundation of piles, then excavating over these a small tunnel, which is first utilized as a refrigeration chamber to solid-

ify the entire mass over the piles, and this tunnel is then enlarged to an excavation in which the structure of the full-sized tunnel is built upon the piles.

“The plan outlined obviates the disadvantages of costly work in compressed air in the main tunnel heading and the

concrete, or any desired material and design may be used. This can be built in exact grade and alignment, a matter of much difficulty with a shield. By the freezing method the tunnel can be located closer to the bed of the river, thus reducing the grade.

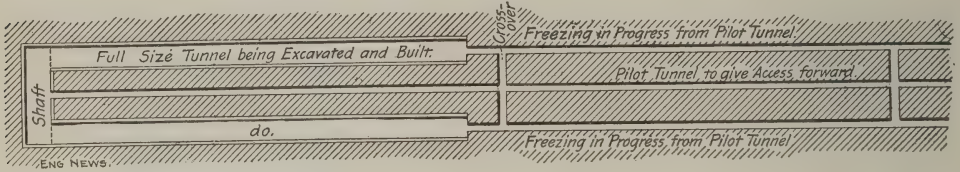

Fig. 2.

hazard to life from the effects of compressed air. It converts the material about the space to be excavated into a rock-like mass, which will almost wholly eliminate the liability to accident, so imminent in compressed air work, from collapses or inflow of water, with its probability of great loss and long delay in the completion of the work.

“The use of the pneumatic shield calls for a heavy and costly structure of cast iron—which material, when it can possibly be avoided, is no longer used in good practice where it is subject to danger of cracking from the vibration of moving trains—a result which would be a most serious matter in a subaqueous tunnel.

“While the freezing method has not yet been applied to horizontal excavations, it has been largely used for vertical shafts, and its application to a tunnel requires nothing not already absolutely proven in actual works. The refrigerating can be done just as is being done in cold storage warehouse plants in all of our large cities. The rate of freezing, the amount of refrigeration required, the strength of frozen earth and the cost of excavating it have been ascertained by work already done, and in addition to the advantages over the pneumatic method of safety and certainty, decided advantages in economy and speed are shown.

“Figure 1 is a sectional elevation

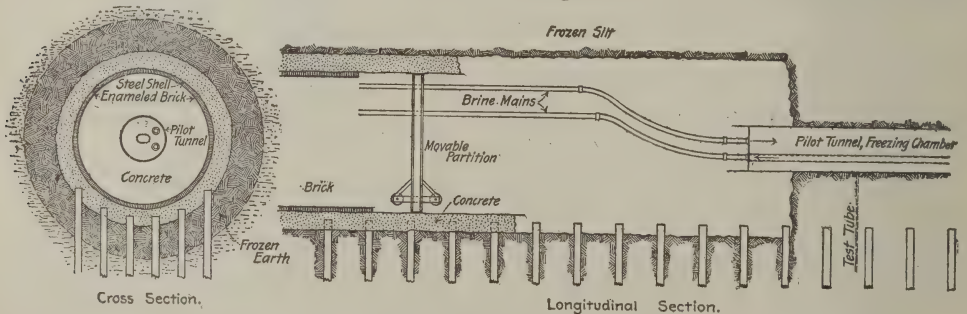

Fig. 3.

“The freezing method permits the excavation of a chamber, in which, open to inspection at all times, a much better and cheaper tunnel wall may be built consisting of a steel shell imbedded in

showing the proposed pile-driving apparatus for sinking the foundation piles. In this drawing A is the tube which is jettied down into the silt, as described, and into which the pile B is telescoped;

C shows the diving bell arrangement, which incloses the head of the pile and within which is the Nasmyth hammer for driving the pile. By means of this apparatus the pile-driving can be carried on below water level and yet the hammer blows be delivered in air as freely as would be the case in operating in the open air. Figure 2 is a diagram showing a possible sequence of operations in constructing the tunnels. As will be seen, three parallel pilot tunnels are first driven; two of these are on the center lines of the proposed tunnel, and the third is midway between these two. The two outside pilots are used for freezing and the middle pilot serves to give access to the work forward. As soon as the freezing has been completed from the

outside pilots, the full tunnel section is excavated and lined at the rear of each. Figure 3 is a diagram showing the freezing pilot and the tunnel work behind in more detail, and is self-explanatory."

The article concludes by pointing out that the projected tunnels under the East River will pass through a more difficult material than the silt of the Hudson, because of the composite character of the formation—it being a strata of mud, gravel sand, quicksand, and disintegrated rock; but it is asserted that there would be no difficulty in constructing a heading sufficiently small in diameter to suffice for a freezing chamber.

The accompanying illustrations are from patent drawings and sketches furnished by the proposer of the plan.

Long-Distance Power Insulation

THE rapid advance in alternating current machinery has brought about a steadily rising pressure for commercial use, and the question of economical and adequate insulation in long distance transmission becomes one of first importance.

That the subject has already attracted the attention of those interested in finding a satisfactory insulator is attested by the paper of Dr. F. A. C. Perrine, read before the Massachusetts Institute of Technology and printed in the "Technology Quarterly."

Dr. Perrine points out that glass is as good a material, perhaps, as can be had when potentials are up to about 25,000 volts requiring an insulator of 7 inches

in diameter, unless the diameters of the lines exceed 1-2 inch, in which case glass is deficient in strength.

When the potentials are lower and the lines lighter, the good properties of glass can easily be enumerated:

1. Its cheapness.
2. Its strength for the purpose.
3. It is easily and accurately inspected; a hammer tap will ascertain what could only be found out by a high potential test in the case of porcelain.
4. Where glass insulators are used on potential circuits within its range, they will give superior uniform insulating results, as porcelain in its mixture of the body material and glazing substance varies from time to time in manufacture, and also the burning

of porcelain in the kiln affects the insulating properties of the material, whereas in the manufacture of glass the materials and composition are practically uniform, and its effect as a dielectric can be more surely depended upon. On the other hand in the consideration of the properties of porcelain, we find that glass is no better for insulation, nor is its surface so good in damp weather against surface leakage. The mechanical strength of porcelain is more than double that of glass, as has been proved by the tests of dropping steel balls from a height upon insulators of the two materials. Glass will often crack from the effect of extreme changes in temperature. The translucency of glass renders the recesses in the petticoat an attractive place for insects to build their nests, especially the dobbler bee, fitting up the interstices of the petticoat and being the eventual cause of the break down of the insulator.

High voltage lines require very large insulators because of the great gaps necessary in the path of the current, where the striking distance is from 4 to 6 inches.

Dr. Perrine states that no dielectric is so strong as one entirely homogeneous. This statement is not fully borne out by the trend of modern practice, which finds it advantageous both in line insulators and other dielectric media to change the character of material through which the stress is exerted. Abundant

examples of this are found among standard manufacturers of high tension apparatus. An ingenious device for preventing the spattering of rain from the petticoat on the cross-arm consisting of a semi-circular groove moulded in the shedding surface of the insulator, has been found to be highly satisfactory in rainy climates.

In determining the potential in a given locality, it is of vast importance to take into consideration climatic conditions, as, for example, in South American coast towns and in Japan.

Objection is found by Dr. Perrine to an insulator that must be cemented together; he calls attention to the fact that the shrinking of the mastic leaves voids and produces strains; if cement be used, its slowness in hardening delays the work and requires large areas for setting out to harden any considerable number of insulators. The one other mastic in use is molten sulphur, which, while better as a mastic than cement, is still more likely to crack the insulators while they are being joined, and, when exposed to light and air, frequently decomposes on the surface, producing sulphuric acid, and, perhaps, catches fire, often resulting in the rupture and fall of the insulator. The insulator which will be entirely satisfactory for this use has not yet been found, but diligent search is being made, which will probably soon result in its production.



Laws Governing Engineers and Firemen

WE give herewith the text of the laws of the State of New York relating to engineers and firemen for Greater New York.

Chapter 635.

An Act to amend Chapter 410 of the Laws of 1882, entitled "An Act to consolidate into one act and to declare the special and local laws affecting public interests in the city of New York," relative to engineers.

Accepted by the city.

Became a law May 22, 1897, with the approval of the Governor. Passed, three-fifths being present.

The People of the State of New York, represented in Senate and Assembly, do enact as follows:

Sec. 1. Section three hundred and twelve of chapter four hundred and ten of the laws of eighteen hundred and eighty-two is hereby amended so as to read as follows:

Sec. 312. The board of police shall preserve in proper form a correct record of all inspections of steam boilers made under its direction, and of the amount of steam or pressure allowed in each case, and in cases where any steam boiler or the apparatus or appliances connected therewith shall be deemed by the board, after inspection, to be insecure or dangerous, the board shall prescribe such changes and alterations as may render such boilers, apparatus and appliances secure and devoid of danger. And in the meantime, and until such changes and alterations are made, and such appliances attached, such boiler, apparatus, and appliances may be taken under the

control of the board of police, and all persons prevented from using the same, and in cases deemed necessary, the appliances, apparatus, or attachments for the limitation of pressure may be taken under the control of the said board of police. And no owner, or agent of such owner, or lessee of any steam boiler to generate steam, shall employ any person as engineer or to operate such boiler unless such person shall first obtain a certificate as to qualification therefor from a board of practical engineers detailed as such by the police department, such certificate to be countersigned by the officer in command of the sanitary company of the police department of the city of New York. In order to be qualified to be examined for and to receive such certificate of qualification as an engineer, a person must comply, to the satisfaction of said board, with the following requirements:

1. He must be a citizen of the United States and over twenty-one years of age.
2. He must, on his first application for examination, fill out, in his own handwriting, a blank application to be prepared and supplied by the said board of examiners, and which shall contain the name, age, and place of residence of the applicant, the place or places where employed and the nature of his employment for five years prior to the date of his application, and a statement that he is a citizen of the United States. The application shall be verified by him, and shall, after the verification, contain a certificate signed by three engineers, employed in New York city, and registered on the books of said board of examiners as engineers working at their

trade, certifying that the statements contained in such application are true. Such application shall be filed with said board.

3. The following persons, who have first complied with the provisions of subdivisions one and two of this section, and no other persons, may make application to be examined for a license to act as engineer :

a. Any person who has been employed as a fireman, as an oiler, as a general assistant under the instructions of a licensed engineer in any building or buildings in the city of New York, for a period of not less than five years.

b. Any person who has served as a fireman, oiler or general assistant to the engineer on any steamship, steamboat, or any locomotive engineer for the period of five years and shall have been employed for two years under a licensed engineer in a building in the city of New York, **or any person who has served as a marine or locomotive engineer or fireman to a locomotive engineer for a period of five years and shall have been a resident of the State of New York for a period of two years.*

c. Any person who has learned the trade of machinist, or boilermaker or steamfitter and worked at such trade for three years exclusive of time served as apprentice, or while learning such trade, and also any person who has graduated as a mechanical engineer from a duly established school of technology, after such person has had two years experience in the engineering department in any building or buildings in charge of a licensed engineer, in the city of New York.

d. Any person who holds a certificate as engineer issued to him by any duly qualified board of examining engineers existing pursuant to law in any State or Territory of the United States and who shall file with his application a copy of

such certificate and an affidavit that he is the identical person to whom such certificate was issued. If the board of examiners of engineers shall determine that the applicant has complied with the requirements of this section he shall be examined as to his qualifications to take charge of and operate steam boilers and steam engines in the city of New York, and if found qualified said board shall issue to him a certificate of the third class. After the applicant has worked for a period of two years under his certificate of the third class, he may be again examined by said board for a certificate of the second class, and if found worthy the said board may issue to him such certificate of the second class, and after he has worked for a period of one year under said certificate of the second class he may be examined for a certificate of the first class, and when it shall be made to appear to the satisfaction of said board of examiners that the applicant for either of said grades lacks mechanical skill, is a person of bad habits or is addicted to use of intoxicating beverages, he shall not be entitled to receive such grade of license and shall not be re-examined for the same until after the expiration of one year. Every owner or lessee, or the agent of the owner or lessee, of any steam boiler, steam generator, or steam engine aforesaid, and every person acting for such owner or agent is hereby forbidden to delegate or transfer to any person or persons other than the licensed engineer the responsibility and liability of keeping and maintaining in good order and condition any such steam boiler, steam generator or steam engine, nor shall any such owner, lessee or agent enter into a contract for the operation or management of a steam boiler, steam generator or steam engine, whereby said owner, lessee or agent shall be relieved of the responsibility or liability for injury which may be caused to person or prop-

*Amendment, April 16th, 1900.

erty by such steam boiler, steam generator or steam engine. Every engineer holding a certificate of qualification from said board of examiners shall be responsible to the owner, lessee or agent employing him for the good care, repair, good order and management of the steam boiler, steam generator or steam engine in charge of or run or operated by such engineer.

c. **Any person or persons violating any provision of this section or any of its subdivisions shall be guilty of a misdemeanor.*

2. This act shall take effect immediately.

CHAP. 733.

An Act to provide for the licensing of firemen operating steam stationary boiler or boilers in the city of New York.

Accepted by the city.

Became a law May 13, 1901, with the approval of the Governor. Passed, three-fifths being present.

The People of the State of New York, represented in Senate and Assembly, do enact as follows:

Sec. 1. It shall be unlawful for any fireman or firemen to operate steam stationary boiler or boilers in the city of New York, unless the fireman or firemen so operating such boiler or boilers are duly licensed as hereinafter provided. Such fireman or firemen to be under the supervision and direction of a duly licensed engineer or engineers.

Sec. 2. Should any boiler or boilers be found at any time operated by any person who is not a duly licensed fireman or engineer as provided by this act, the owner or lessee thereof shall be notified, and if after one week from such notification the same boiler or boilers is again found to be operated by a person or per-

sons not duly licensed under this act, it shall be deemed prima facie evidence of a violation of this act.

Sec. 3. Any person desiring to act as a fireman shall make application for a license to so act, to the steam boiler bureau of the police department as now exists for licensing engineers, who shall furnish to each applicant blank forms of application, which application when filled out shall be signed by a licensed engineer engaged in working as an engineer in the city of New York, who shall therein certify that the applicant is of good character, and has been employed as oiler, coalpasser or general assistant under the instructions of a licensed engineer on a building or buildings in the city of New York, or on any steamboat, steamship or locomotive for a period of not less than two years. The applicant shall be given a practical examination by the board of examiners detailed as such by the police commissioner, and if found competent as to his ability to operate a steam boiler or boilers as specified in section 1 of this act, shall receive within six days after such examination a license as provided by this act. Such license may be revoked or suspended at any time by the police commissioner upon the proof of deficiency. Every license issued under this act shall continue in force for one year from the date of issue unless sooner revoked as above provided. Every license issued under this act unless revoked as herein provided shall at the end of one year from date of issue thereof, be renewed by the board of examiners upon application and without further examination. Every application for renewal of license must be made within thirty days of the expiration of such license. With every license granted under this act there shall be issued to every person obtaining such license a certificate, certified by the officers in charge of the boiler

*Amendment, May 1, 1900.

inspection bureau. Such certificate shall be placed in the boiler room of the plant operated by the holder of such license, so as to be easily read.

Sec. 4. No person shall be eligible to procure a license under this act unless the said person be a citizen of the United States.

Sec. 5. All persons operating boilers in use upon locomotives or in government buildings, and those used for heating purposes carrying a pressure not exceeding ten pounds to the square inch, shall be exempt from the provisions of this act. Such license will not permit any person other than a duly licensed engineer to take charge of any boiler or boilers in the city of New York.

Sec. 6. This act shall take effect immediately.

State of New York,
Office of the Secretary of State, } ss.:

I have compared the preceding with the original law on file in this office, and do hereby certify that the same is a correct transcript therefrom, and the whole of said original law.

Given under my hand and the seal of office of the Secretary of State, at the City of Albany, this 23d day of May, in the year one thousand nine hundred and one.

(I. R. Stamp.)

(Seal.)

J. B. MONGIN,
Deputy Secretary of State.

Some Details of the Plant in the Broadway-Maiden Lane Building

By R. ROWLEY

OWING to the increasing value of floor space in the modern first-class office building, the room occupied by the engine and other machinery necessary for its complete equipment becomes a matter of considerable importance. Therefore, the space allotted to the engine room and mechanical department is somewhat small; but the Broadway-Maiden Lane Building, having one of the largest and best-equipped plants of its kind, shows an installation in far less space (4,784 square feet) than in any other building in New York.

The steam generators of the Heine type, of 300 horse power each, with the Treadkill shaking bars, and with an exceptionally fine natural draft allow-

ing the burning of a low-grade fuel, which, after several comparative tests, has been found to be more economical than the higher grades.

The electric generators were built by the Western Electric Company and are three in number, two 100 kilowatts each, and one 75 kilowatts, and are driven by Ballwood engines. One important fact in reference to the steam piping is that a Cochran vertical separator is close to the stop valve, thus minimizing the danger of water in pipes which is always a source of danger to the present high speed engine of modern type with a minimum amount of clearance.

The following table shows how the load varies in time, current in amperes,

voltage, current through shunt winding, revolutions and steam pressure for each machine:

100 Kilowatts, No 3.

Time.	Current in amperes.	Volts.	C. S.	Rev.	Steam.
9.20	0	115	13.5	252-255	105
9.20	575	120	13.5	248-252	108
9.30	625	120	13.5	"	112
10.00	775	120.5	13.75	"	112
10.35	820	119.5	13.5	"	113
11.00	760	120	13.75	"	"
11.30	730	120	13.75	"	"
12.00	700	120	13.5	"	"
12.30	680	120	13.25	"	"
1.00	600	119	13.5	"	"
1.30	625	119	13.5	"	"
2.00	800	119.5	13.5	"	"
2.30	800	119.5	13.25	"	"
3.00	770	119.5	13.25	"	"

The varying load is due to tenants turning off lights on account of heat created.

The power to operate the elevators, six in number, is supplied by three compound Worthington pumps regulated by Ford governors. There are two pressure tanks, one in the engine room of 2,500 gallon capacity, and one on the roof of 5,000 gallon capacity, which add to the steady and smooth operation of the elevators, as the top tank furnishes a ready supply when several elevators are taking power at one time.

A drip filter has recently been added

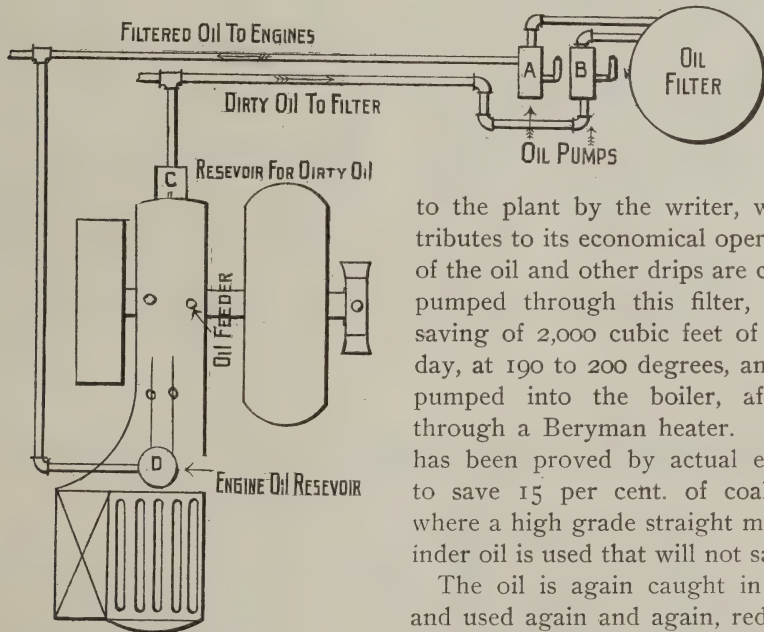

Oiling and Filtering Apparatus.

75 Kilowatts.

Time.	Current in amperes.	Volts.	C. S.	Rev.	Steam.
9.00	0	115	13.4	278	115
9.10	400	120.5	12.75	270	103
9.45	420	120.5	12.3	274	100
10.15	420	118	12.9	270	108
10.45	425	120	13	271	108
11.15	420	120.5	12.75	270	108
12.00	400	119.5	13.25	270	108
1.00	360	120	13.25	272	102
1.30	520	121	13.25	272	102
2.00	560	121.2	13.25	270	102
2.30	600	121.5	13.25	270	103
3.00	590	121	13	270	103

to the plant by the writer, which contributes to its economical operation. All of the oil and other drips are caught and pumped through this filter, causing a saving of 2,000 cubic feet of water per day, at 190 to 200 degrees, and is again pumped into the boiler, after going through a Beryman heater. This filter has been proved by actual experiment to save 15 per cent. of coal per day where a high grade straight mineral cylinder oil is used that will not saponify.

The oil is again caught in the filter and used again and again, reducing the cost of cylinder oil to practically nothing. Of course, there is a small amount of oil lost, but a barrel of cylinder oil will last under the above conditions at least three months, even taking into consideration that high speed engines require a comparatively large amount of oil.

The accompanying sketch of the filter will clearly illustrate its principle and the simplicity of construction. Another important feature is the by passing of

all pumps, namely, any pump from the elevator pump to the cesspool pump can be used in case of emergency, either on the elevator system or boiler feed and fire and hose line.

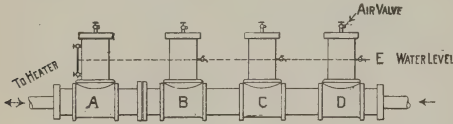

Fig. 2.

B C D are filled with excelsior, A with charcoal, the oil being arrested while the water passes through the filter causes it to float by gravity to the water level E, from whence it is drawn off each day and again used; the excelsior is changed every week.

The electric system of signals for the elevator cars was installed by Mr. Peterson, of the Central Bank Building, and is very effective and unique, having only three sliding contacts, which are placed in the center of the elevator shaft and easily accessible, and operated by sprocket wheels, which are on the top

grating of shaft. It is also arranged so that by the manipulation of the push-buttons in the main corridor the elevator starters can signal the elevator operator in any car and at any floor, thus maintaining a regular and systematic running of each individual car.

The coal and ash handling device was installed by the Cameron Co. and allows of the easy handling of coal and ashes, thereby dispensing with a coal passer. A scale is attached to the coal trolley, which enables us to keep an accurate account of coal burned and the percentage of ash.

The oiling system was also installed by the writer. This saves a large amount of oil and labor. For explanation, see Figure 1. A and B being two pumps, B takes the dirty oil from the reservoir C and pumps it into filter, whilst A pumps the clean oil back to the reservoir D, from whence it supplies the oil feeders through pipes to the various journals and pins, without the aid of the old-fashioned oil-can feeder.

Some Suggestions to Engineers

A FEW words on the management and care of steam boilers may be of interest to your readers. In the first place, the responsibility of one in charge of steam boilers is infinite, and a due sense of the importance of the responsibility is essential to the making of a good engineer. Under ordinary running conditions, successful operation consists of effective fire, ample supply of water, invariable steam pressure and uninterrupted steam supply. One in charge must be able to handle any emergency without error, to the end that accidents may not result; he should be

prepared, by having previously anticipated in his own mind, all possible accidents. When emergencies arise, there is often no time to think, and one must act almost intuitively. He should be familiar with as much of the boiler making and machinist trades as to enable him to make minor repairs and keep the plant in a condition of efficiency. He should study cause and effect by seeing that causes put into operation have their intended and proper effect, and again upon seeing an undesirable effect by working back from it; not giving up

until he has discovered its cause. For instance, some days the boiler may not steam as well as usual. Find out why; examine heating surfaces, they may be coated more than usually; clean them and find the cause of the excess of soot. Apply draft gauge to the stack and note the direction of the wind; you may find that relative direction of wind has an important influence on steaming of a boiler; the location of the surrounding buildings may have a considerable influence, and you can allow for them by heavy or light firing, as the wind direction may demand. You may find the uptake temperature higher than it should be. Find the cause. Again, coated heating surfaces may allow the heat to slip by instead of generating steam. Again, a low temperature may not indicate good operation, but may indicate, on the contrary, that too much air is getting into the furnace, holding its temperature from the best steam making point.

Keep your fires clean, clear of clinkers and of an even depth. The depth at which they may be carried is determined by the nature and size of the fuel and the intensity of your draft. Strong drafts in general demand thick fires and vice versa. The secret of successful firing is to find the best depth for existing conditions in the maintenance of the depth, allowance being made for ash accumulation, and in supplying fuel in such a manner as to prevent holes and uneven thicknesses; also to introduce coal as expeditiously as possible, to prevent inrushes of cold air. The fire should be kept bright underneath and the ash-pit clear; the ashpits should never be allowed to become filled with ashes, for the result is a checking of the draft and danger of destruction of the grates. A bright and uniformly lit up ash pit indicates good firing. Some engineers are forever watching the ash heap, looking

for stray bits of coal, apparently thinking when fuel is changed into a high grade of ashes that economy must surely be the result. We must look further than this; we must get the most perfect combustion in the furnace; we must have clean heating and inside surfaces, in order that the water may absorb the utmost quantity of heat from the gases. Observe at what height of water level the boilers will steam easiest, and by constant and regular feeding maintain it. Aside from the fire, the operation of the boiler in order to make steam regularly and in ample quantity, mainly consists in adjusting the draft, in keeping the supply of feed-water proportional to the demand, thereby reducing danger of exposing heating surface; or, on the other hand, causing the boiler to prime and send over wet steam. A maintenance of water level insures safety, while an invariable steam pressure insures efficiency. Absolute safety, if the boiler is in good repair, and efficiency, depend not only on skillful firing and feeding, however; all the apparatus upon which the boiler depends must be capable of efficient work. Feed pumps, injectors, safety valves, check valves, water columns, pressure gauges, stop valves, blow-off valve, etc., must all be in good serviceable and reliable condition. Safety valves should be tried very often to insure proper working conditions. Pressure gauges should be compared with a standard test gauge often in order to determine whether its error is of importance. Leaky blow-off or other valves should be repaired at the earliest opportunity, as they are the most expensive leaks about a boiler room. Feed apparatus should receive the strictest attention and be maintained in a state of highest efficiency. The most important duty of one in charge of a boiler is to maintain a proper water level. In getting a boiler ready to clean, work off

the steam gradually and allow the boiler to cool down, leaving the water in it until ready to begin operations.

It is well to take an inventory of everything that one takes into a boiler, and see that it is checked up before closing it. Loose bunches of waste or other materials may be the cause of serious trouble if left in a boiler. Never allow fuel to be spread on the grate of an empty boiler; always have water in it before attempting to touch the furnace. In blowing off a boiler, never allow your hand to leave the valve until it is closed; for if you do you are likely to have an explosion.

Never fill a boiler with cold water while it is hot; extreme contraction might result in serious disruption of tubes, shell, etc. Gauge glasses are not reliable, therefore try gauge cocks occasionally. Keep your water gauge clean,

as well as all other apparatus connected with the boiler. Don't try to improve on the plant of which you have just taken charge too fast, because first impressions may be based on imperfect knowledge as to why things are as you find them. The history of a plant is of great importance, for it is valuable to know what has happened to any of the apparatus and how the trouble was gotten over and repaired. The history is therefore valuable in that it will enable one to avoid the same error or to repair recurring damages. In conclusion, let me urge that while the tools of a fire-room are not of a delicate nature, still they are very often abused; also let me suggest to employers that a little expenditure for oatmeal and ice may prevent the use of that composition which cannot be recommended as a scale preventive.

Cannot Be Refused Service

OFFICIALS of the Citizens' Telephone Company, of Grand Rapids, say that if the statement is true that the Bell Telephone Company refused long-distance service to a person at Newburn, whom it was claimed owed them money, when payment had been tendered for the desired service, the company, under the laws of this State, was liable to revocation of its charter.

"This case as reported," said Secretary Fisher recently, "is similar to one we had several years ago. It occurred at Northport, and the man wanted connection with Grand Rapids, if I remember correctly. He was in bad standing with the company, owing us for service for some time back, and so unsuccessful were we in securing payment we took his telephone out, and refused to give him further service until he paid up in full. In pursuance of this mandate, we

refused him service over the long-distance line, and he promptly called the attention of the Attorney General's office to the matter.

"We believed we were acting well within our rights, when we received word from the Attorney General that we must give this man service, or anybody else, when they applied and tendered the money, or our charter would be annulled. We gave the service very promptly, and have never since attempted to enforce payment of back bills by this method. As I understand the ruling of the Attorney General in that case, we were placed on the plane of a common carrier, and have no more right to refuse service to any one than has a railroad company or any other corporation which has been granted special privileges."

The Annunciator System in the New York Stock Exchange

By BENJAMIN F. EINBIGLER

AMONG the many electrical devices installed at the New York Stock Exchange Building is the Einbigler Patent Electric Annunciator, which ranks second to none in its practical utility and importance to the business of the stock broker. This fact, however, is not generally known to the outside public or the casual visitor to the Stock Exchange, as few understand the uses of the annunciators and how important a factor they are in the hustling, bustling excitement which is in order on every business day from ten to three o'clock on the floor of the "Exchange." On the north and south walls of the board room floor, and directly in the center, are the two annunciators, which look like large blackboards, 28 feet across the face of the wall, and 28 feet in height. The bottom of each annunciator is 20 feet from the floor, so that the uppermost tier of numbers on the annunciator is 48 feet high. Each annunciator is divided into 1,200 squares, 9x9 inches being the dimension of each square, across the center of which a shield is hung, thereby concealing a number painted, half on the shield and half on the lower, or covered section, of the square. This shield is pivoted, so that when it is turned upwards a distinct number is brought to sight, visible from any part of the board room floor. The numbers start in the lower left hand square of the annunciator, and run consecutively from 1 to 1200. Each member of the Exchange has a number which is put up simultaneously on both annunciators,

whenever he is wanted for the purpose of receiving orders, or for the transaction of other business, at some specific point, viz., at his private telephone booth, at the Wall street door of the Exchange, at the New street lobby, etc., as the case may be.

In order that members may experience no difficulty in locating their numbers when they are put up, the annunciators are divided into nine sections by bronze frames running both horizontally and perpendicularly across the face of the annunciator. Owing to the lightning like rapidity of the changes which occur in the price of stocks, it is absolutely necessary that a broker, in order to transact his business expeditiously, must receive his instructions, orders or other information with the least possible delay; therefore, it is incumbent that his number on the annunciator be shown instantaneously with the receipt of an order over the 'phone or the arrival of a messenger at any of the doors with information, etc., to be conveyed to him, and for this purpose a complicated but ingenious system of push buttons has been perfected. Push buttons are placed at every possible point, each place being a station in itself. The main operating station, however, is the annunciator keyboard, which is placed on a balcony, directly below the annunciator, on the south side of the board room floor. This keyboard is ten feet long and five feet high and is made up of 2,400 buttons, there being one button to raise the shield, and one button to lower it, for

each of the 1200 numbers in the annunciator. At each door leading to the board room a sub-station is placed, from which, by push buttons, certain numbers are put up notifying the member, represented by the number, that he is wanted at that particular sub-station. Each telephone booth may be, and most of the 480 odd booths are, sub-stations from which at least two, and as high as twelve numbers, in some cases, are operated.

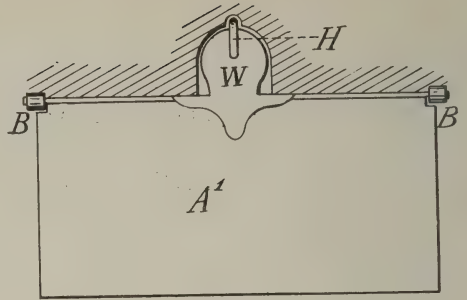
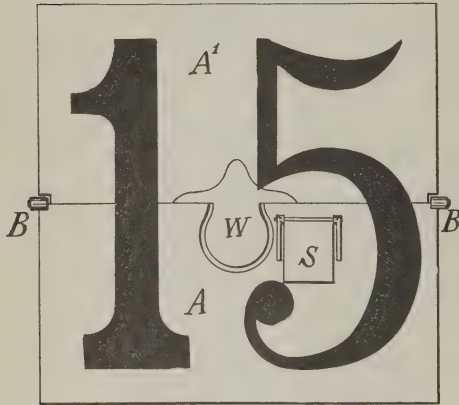

FIG. 2

Main Signal "Normal."



A'-SHIELD *B*-PIVOT. *W*-WEIGHT.
S-AUXILIARY SIGNAL.

FIG. 1

Main Signal Displayed.

The system by which the annunciators are operated is as follows: In the center of the shield, on its pivoted edge, a weight is fastened, designed to swing the shield up to its open position, after it shall have been started. On the rear of the board and directly in back of each number, are placed two electro-magnets, one of which starts the shield in its downward or closing swinging movement and the other of which starts the shield in its opening movement to disclose the number. On each side of each electro-magnet a pole piece is attached which co-acts with an armature, swinging between the two electro-magnets.

An upwardly extended lever is fastened to the armature, and at its upper end the lever has a forwardly extended operating rod, which extends through an opening in the face of the annunciator, and directly over the weight previously referred to. The end of this forwardly extended rod is bent into a hook. A wire attached to one electro-magnet is run to a push button on the keyboard, while the other electro-magnet is attached to a corresponding button on the same board by a wire. When the first push button is pressed, the ensuing contact with the wire causes the magnetic current in passing through the electro-mag-

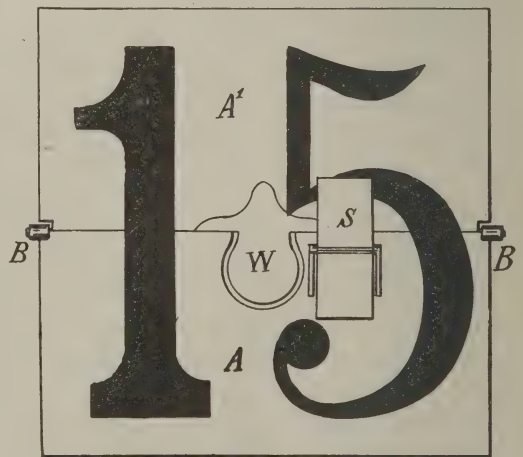
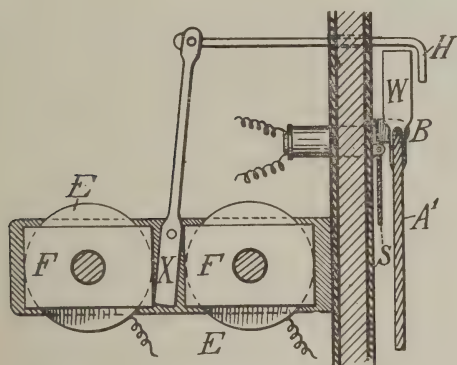

FIG. 3

Main Signal, Showing Auxiliary Call.

net to which the wire is attached, to attract the armature over to the pole piece on the magnet. As the armature swings rapidly back, the upwardly and forwardly extending rods attached to the armature, move backward with the armature, and the hook on the end of the rod, engaging the weight on the shield, swings it upward. When the other button is pressed, the current passes through the other magnet, causing the armature and rods to swing forward against the shield, closing it.

As there is only one main keyboard station, and it is necessary to operate both annunciators simultaneously, the wires brought down from the south side annunciator to the keyboard, are carried down from the keyboard to a terminal board on the floor below the board



E-ELECTRO-MAGNET. *H*-HOOK.
F-POLE-PIECES. *X*-ARMATURE.

FIG. 4

Cross Section of Annunciator.

room. This terminal board is 22 feet long and 8 feet high. The wires from all sub-stations are also brought into this terminal station and attached to the board, as are also all the wires from the north side annunciators, which connect with a corresponding wire from the south side annunciator. The total number of separate wires brought to this terminal

board and attached thereto in such a manner that the individual identity of each wire is known and never lost, amounts to about 8,000 wires.

Mention has been made of the fact that a broker may be called from various sub-stations, and in order that he should know immediately to what place he should go, auxiliary signals were fastened to the main numbers, which are similar in construction to the main shields. From one to seven vari-colored shields, two inches in width by three inches in height, are fastened on the lower half of the number. When the member's number is disclosed without any auxiliary signal, he is wanted at the main keyboard station; when the number is disclosed with a red auxiliary signal, he is wanted at his private telephone booth; a green auxiliary signal, for the New street lobby, north; a yellow auxiliary signal, for the general telephone lobby, and so on, a different colored signal is disclosed to show the member exactly where an order awaits. By means of the main signal or number and the seven auxiliary signals, it is, therefore, possible to summon a member on the board room floor to eight different places.

Although the operation of the annunciators and the system of auxiliary signalling is exceedingly simple, in which fact lies its greatest value for usefulness and utility, the installation is not only complicated, but had to be performed with the greatest of care and vigilance. It would not be generally credited, but the installation of this system has required a greater amount of wire than any other of the electrical branches or systems in the building, such as the telephone service or the electric lighting. That this is true will be readily apparent when the fact is mentioned that 1,300,000 feet of heavy, rubber-covered copper

The Human Body an Electric Battery

THAT the human body carries latent within it a certain electric current, varying with different conditions, has long been recognized, but it has remained for Dr. John W. Girdner, of New York, to demonstrate fully and satisfactorily that this current is sufficient to operate a telephonic device in connection with a bullet probe, the adoption of which by the various hospitals and the armies and navies of the United States, Germany and Japan and other governments as a standard surgical instrument, has further emphasized its practical utility. A peculiar

probes are also included in the set for use in probing for leaden gunshot or bullets; from which it appears that while the probe and bulb or terminal must always be of the same metal, they must be of a different metal than that of the bullet or gunshot, otherwise the results are wholly negative. The following description of the instrument may be of interest.

To each of the binding posts of a telephone receiver an insulated flexible wire about four feet long is connected. At the free end of one of these wires a bulbous piece of aluminum is attached. At

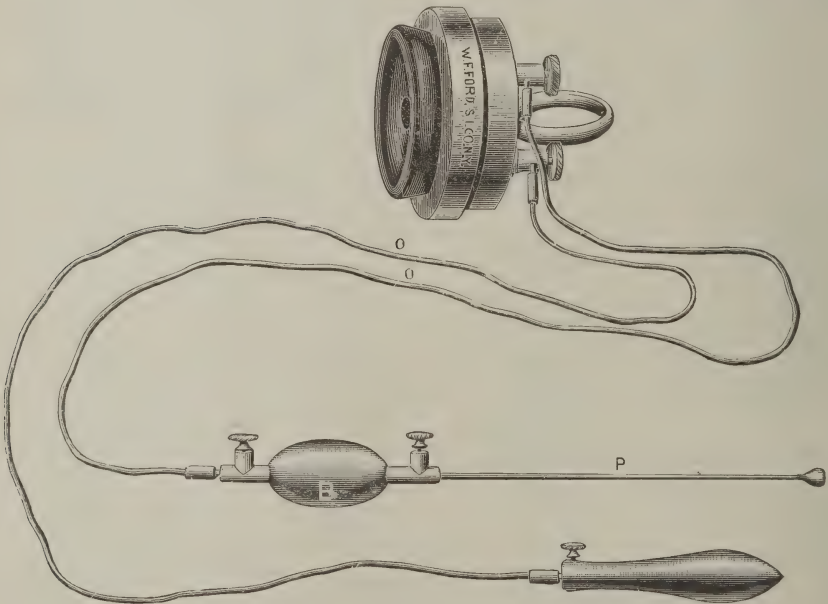

Fig. 1.

quality of the instrument lies in the fact that where the bullet or gunshot probed for is of steel, a steel probe fails of results; accordingly, aluminum probes are included in the set to be used in connection with an aluminum bulb or terminal, as shown in the illustration. Steel

the free end of the other wire is a suitable handle B, in which a probe P may be placed and held by clamp screws. The internal arrangement of the handle must be such that a perfect electrical contact shall exist between the ends of the probe and that of the wire that ter-

minates in the handle; the same is true for the end of the other wire and bulb, or terminal.

The simplicity of the operation of the device, in connection with its unerring results, commends it instantly for rapid and certain work; the surgeon first inserts the handled shape bulb or terminal into the patient's mouth; then holding the probe in his right hand, the telephone receiver to his ear with his left hand, he gradually probes the wound; upon contact, however slight, with the metallic bullet or gunshot, he is simultaneously apprised by a sharp, ringing, metallic click through the telephone receiver solely by the current emanating from the body of the patient operated upon, and the bullet or metallic substance is immediately located; the fact that when the probe comes into contact with bone or cartilaginous substance no telephonic response is given, is a significant element in one's estimation of the practical value of the device, which value is in no sense detracted from by reason of the fact that positive results could be obtained in the way of telephonic responses in the case of a dead body or a mere mass of wet earth.

If it were possible accurately to measure this infinitesimal electric current in the human body so that comparative

tests could be made and records kept, the impetus thereby given to electro-chemical science would, in our opinion, be of incalculable value, as it would indubitably open up new fields to the physician and surgeon in his treatment of human ills, affording him fresh scientific data obtained by certain methods for his diagnosis, and minimizing the chances for the proverbial disagreement rife among members of the medical profession, because of the lack of data of this sort. Indeed, any instrument capable of showing accurate results that will be so far forth likely to do away with medical or surgical "educated guesswork," must of necessity be hailed by the profession and humanity in general as a harbinger of the scientific millenium.

We are of the opinion that mechanical volt and ammeters will not solve this problem, but we are inclined to the theory that a meter something on the lines of the Edison chemical meter would at least serve the purpose of stimulating investigation along these lines. However, we do not pretend to prophesy concerning the method to be followed, but we do feel that this field of investigation is well worthy the attention of our greatest electrical experts, and if success should follow such investigation, the beneficial result to humanity would be infinite.

Editorial Note.—We print elsewhere in this number of "The Electrical Age" a scholarly exposition of the more technical features of the subject touched upon in the above article, from the pen of Percy G. Stiles, Ph.D.

It will be observed that Dr. Stiles sounds the note of warning against the usual loose talk and popular misconceptions concerning the presence of electric-

ity in the human body; while doing so he has, indeed, deserved well of those whose misconceptions have hitherto led them into error in practice. It is with no intention of attempting to controvert Dr. Stiles that we print the above article, but we believe that additional interest will be loaned to the subject by the publication of the two papers as setting forth two points of view.

The Electrical Phenomena of the Animal Body

By PERCY G. STILES, Ph. D.

IN the popular mind there is much the same vagueness and confusion in regard to electrical phenomena and respecting the nature of physiological processes. In view of this sense of mystery it is not strange that the electric properties of the animal body are seldom understood. There is a tendency to exaggerate their importance and to find a relation between them and the most remote and occult phases of psychic life.

This is an unfortunate impression. The electric currents produced in the living tissues are but one manifestation of an energy which appears at the same time in the more obvious forms of heat and muscular movement. The source of this energy, irrespective of its form, is found in the chemical reactions going on in the cells. The science of the nineteenth century has taught us that the organism is not exempt from the principle of the conservation of energy. In the living body as truly as in the locomotive only so much energy as is stored in the fuel can be manifested.

Electric currents then, when we detect them in the tissues, are produced by chemical changes such as underlie all the tangible expressions of life. And the quantity of energy developed as electricity is but a small fraction of the total. It is very small indeed when compared with the energy which goes into the performance of muscular work, and this in its turn is much less than the energy spent in maintaining the temperature of the body. But there is one exception to

the statement that animals do not produce electric currents of much intensity. It is found in the case of electric fishes, to which reference may be made later.

To demonstrate the electric currents produced by ordinary animals, it is necessary to use delicate instruments. High resistance galvanometers may be employed on the sensitive capillary electrometer. When the two terminals of either instrument are placed upon the skin at random, a current is pretty sure to be indicated. Its direction cannot always be predicted. At least one learns from a series of such trials that his body is not iso-electric—that differences of potential exist at different points. To reach more definite conclusions, it is best to study a single organ rather than the whole complex system. Such an object is the "surviving" muscle of a frog.

A muscle from this animal may retain its vital properties for hours after it is removed from the body. It may be made to contract by various means. While it is alternately resting and contracting, its electrical condition may be noted. Observation has shown a fact which is of very general application. The active, contracting muscle has a lower potential than the same muscle at rest. Refined methods of study show that in the instant when the contraction process has begun at one end of a muscle, the other end remaining relaxed, the active region is electrically negative to the inactive. The galvanometer circuit connects these two regions, and the current through it is said to flow from the resting

to the active section. This current is called the "current of action," and the depression of potential in the active fibres is called the "negative variation." Negativity is hence a sign of active process in a muscle, and the same is true of other tissues. The chemical changes which accompany the contraction of a muscle are in the nature of a decomposition—an explosion if we choose—and so we may associate the "negative variation" with destructive processes in the tissue, processes which use up the stored fuel and lead to exhaustion at last.

Unlike the muscles whose contraction we can see, the nerves betray to the eye no sign of their activity. But nerves as well as muscles change in their electrical potential when they are functioning. The passage of the nervous impulse is marked by a "negative variation." The nature of the nervous impulse is not understood, but it must not be thought of as an electric current. A "current of action" accompanies it, but this electrical manifestation is no more the traveling process in the nerve than the same variation in the potential of a muscle is the visible contraction. The chief thing to be remembered is that in nerves, as in muscles, a lowering of potential is the sign of activity, and presumably of chemical decomposition.

This principle applies to the glands in which the various secretions are produced. Here, as in muscles and nerves, the more active cells are negative to those at rest, and "currents of action" flow from the latter to the former when a conductor is supplied.

The simple and consistent practice of associating functional activity with electro-negativity has become possible since the German physiologist, Hermann, corrected the earlier view of the matter. Before his researches were made it had been supposed that muscles in a state of

rest were traversed by currents. Hermann showed that normal resting muscles are iso-electric, and vastly simplified the problems of electro-physiology. What had been described as "currents of rest" he showed to be in fact "currents of injury." The principle that negativity is the manifestation of activity in living cells has to be coupled with another. Injured or dying tissue is negative to normal tissue. Thus, when one end of a muscle is crushed or burned, and a galvanometer is connected with this injured end and with a normal section, the current flows from the uninjured part to that which has suffered violence. This is a "current of injury," and it is usually much stronger than any "current of action," and because this is so, the injured end remains negative to the normal cells, even when the latter are excited to their very utmost activity.

A moment's thought will suggest the meaning of these facts. The "negative variation" accompanying activity was seen to be the index of a destructive process in the cells. So it might well be expected that the more profoundly destructive changes attending local death should find expression in a like variation, but one quantitatively greater.

The electric currents from the animal body result from local differences of potential, and these local differences arise from uneven conditions of nutrition and activity. The currents are slight and quite incidental to the main processes of life. In the electric fishes organs are present which do discharge surprisingly intense currents. These organs are said to be modified muscles, but while in the typical muscle the electric phenomena are subordinate to the contraction, here movement is suppressed and the "action current" increased to the value of as much as 200 volts.

The Electrical Age

Incorporated April, 1902

CHARLES A. LIEB, - - - - PRESIDENT

New York, February, 1903

Volume XXX

No. 2

Published Monthly.

Subscription, \$1.00 per year. Single Copies, 10 Cents.
(\$2.00 Per Year to Foreign Countries.)

20 BROAD ST., NEW YORK. Telephone 1628 Cortlandt.

THE ELECTRICAL AGE (Incorporated)

Entered at New York Post Office as Second Class Matter.
Copyright, 1902, by THE ELECTRICAL AGE.

TO ADVERTISERS

Changes for advertisements and new advertisements **must** be in this office by the **20th** of the month to be included in the issue in the month following. The advertising pages carry printed matter measuring five and a half by eight inches. Cuts intended for use on these pages should be made to accord with these measurements.

Correspondence and semi-technical articles, with suitable photographs for reproduction, or cuts, are invited. Accepted matter will be promptly paid for. We cannot be responsible for any unsolicited manuscripts, but when stamps are enclosed all unavailable matter will be returned. Postage must always be fully prepaid. Cuts to be available for illustrating articles must conform to the column or page measurements. The columns are $2\frac{1}{2}$ inches wide. Cuts for single column use should not exceed that width. Cuts to go across the page should not be more than five inches wide, and full page cuts may not exceed $4\frac{1}{2} \times 8$ inches.

The Stationary Engineer.

THE stationary engineer in a modern building, especially the skyscraper requires a practical knowledge of many appliances and systems which have become necessary in the modern equipment of buildings.

Besides the operation of steam boilers and engines, under the supervision of the engineer, comes the elevator, the wiring, the generators, the heating, the refrigerating, and, in many cases, the storage battery.

To be competent in all the various branches it requires the exercise of more than ordinary ability, and can only be learned by practical schooling in the plants themselves. Many perplexing problems arise due to the derangement

of portions of the plant where to seek the cause of the trouble is more difficult than to apply the proper remedy; and also conditions arise where ingenuity is required in order to devise methods of overcoming difficulties and to meet the requirements of the tenants, and many neat wrinkles have been the outcome of the simple solution of perplexing problems arising from day to day, when some part of the equipment fails to operate satisfactorily.

In a modern building the various demands of tenants are often exacting and sometimes unreasonable, which adds much to the burden of the engineer; and very often the landlord or agent will promise things to tenants which, on account of the layout of the plant, are practically impossible to comply with. If the landlord would confer with the engineer before agreeing to rearrangements of these special parts of the plant to comply with the desires of the tenant, it would save many of the annoying troubles that the stationary engineer has to contend with. The changing of radiators agreed to by the agent will often make their connection unsatisfactory, as they would have to be supplied by steam from piping already overtaxed; another cause is where agreement is made for extra lamps where the service wiring is carrying all the current it should with the lights originally installed; and often tenants will connect electrical appliances to the wiring system which consume more current than the conductor system was designed to carry, and from these changes, if the heating or lighting systems are not satisfactory, the engineer is held at fault.

The above cases are cited as a few of many causes which require patience and ingenuity on the part of the engineer. In power buildings the engineer is confronted with problems of power trans-

mission, either by belting or electricity, which he is called on to solve, but which are often within the province of the millwright.

It is proverbial that tenants are recklessly extravagant in the use of heat, light and power where they are supplied as part of the rental system. We have often seen in offices and hotels the occupant of a room open a window directly over a radiator to cool the room rather than turn off the steam. The same extravagance leads to the burning of light in a sunlit room; and there are many other wasteful practices which are becoming quite common, and are in most cases beyond the control of the engineer of the building; yet he is called to account by the owner for the increase of operating expenses.

The low rate of interest earned by many of our large buildings could be considerably increased if the owner would consult the engineer in regard to reducing the consumption of light, heat and power, and, in some cases, water. The leases, as a rule, with the tenant do not restrict nor caution economy in the use of any conveniences supplied to him, and yet the addition to his premises of more light and heat increase the cost of plant operation.

Light can be readily metered, and if the lease calls for a given number of lamps, if more lights were desired later they could be connected through a meter and charged for accordingly. The amount of power delivered is generally crudely figured from the size of the belt. In order to limit the power consumption within the terms of the lease, a receiving pulley could be placed on the shafting where the power is delivered so arranged to receive a transmission dynamometer which could be connected to it from time to time, and the actual power consumed could be determined;

as it is found in the majority of cases that the tenant allows the shafting to get out of line and the machinery to run when not doing any useful work.

The above suggestions are given to bring the attention of the owner or agent of buildings to methods of reducing the numerous losses, and by studying economy in operation, many small wastes can be curtailed, the aggregation of which seriously detracts from the possible earnings on the investment, and the engineer's life would be less burdensome.

The element of responsibility of the engineer of isolated plants has in late years largely increased, due to the installation of high speed elevators, higher steam pressures and cramped quarters in which his assistants must work, which keep him constantly on the lookout that no accident can occur due to negligence.

Announcement.

The New York Board of Education announces a series of lectures upon scientific subjects of peculiar interest to engineers and mechanics who are seeking to utilize their spare time in bettering their knowledge of their respective avocations.

The subjects and lectures announced for the month of February include "Electricity in Motion; Its Magnetic Effects" by Prof. E. R. von Nardroff, to be given in the Great Hall of Cooper Institute, at 8 p. m., on Wednesday, Feb 4th, also on Saturday, Feb. 7th, in the American Museum of Natural History, 77th street and Central Park West; "Electricity in Motion; Its Inductive Effects," by the same lecturer on Saturday evening, February 14th, in the Great Hall of Cooper Institute; "Cathode Rays, X Rays, Radium Rays," by the same lecturer on Saturday evening, February 21st, in the Great Hall of

Cooper Institute; "Electro-Magnetic Waves; Their Properties and Uses," by the same lecturer, for Wednesday evening, February 25th, in Cooper Institute, and on Saturday evening, February 28th, in the American Museum of Natural History; "The Electric Motor and Its Application," illustrated by stereopticon views and experiments, by Mr. W. W. Ker, on Wednesday evening, February 4th, in Y. M. C. A. Hall, 92nd street and Lexington avenue; "Electric Arc Lighting," by the same lecturer, illustrated by stereopticon views and experiments, on Wednesday evening, February 11th, in the same hall; also on Monday evening, February 9th, in Columbus Hall, 60th street between Columbus and Amsterdam avenues; "Incandescent Electric Lighting," by the same lecturer, on Wednesday evening, February 18th, in Y. M. C. A. Hall, and again on Monday evening, February 16th, in Columbus Hall; "Electrical Methods of Communication," by the same lecturer, on Wednesday evening, February 25th, in Y. M. C. A. Hall, and again on Thursday evening, February 26th, in Columbus Hall; "Electro-plating and Electrotyping," by the same author, on Monday evening, February 23rd, in Columbus Hall; "Electro-Chemistry and Some of Its Applications," by Prof. William C. Peckham, for Tuesday evening, February 10th, in Judson Memorial Hall, Washington Square South; "The Chemistry of the Electrical Battery, Primary and Secondary," by the same lecturer, on Tuesday evening, February

17th, in Judson Memorial Hall; "Phosphorescence, Fluorescence, and X Rays," by Prof. William Hallock, on Wednesday evening, February 25th, in Judson Memorial Hall.

The courses are designed to meet the requirements of practical students of the various subjects, whose time for investigation and experimenting is necessarily limited, and, as such, deserve their heartiest co-operation, patronage and attendance.

IT will be interesting to observe the flood of newly coined words which will be injected into English by the arrival-to-stay of wireless telegraphy. It is rather early to predict that the word "marconigram" will eventually come into common usage, and the proper designation of a message sent by wireless telegraphy has, as yet, not been determined upon.

The "short, sharp and decisive" propensity in speech of the commercial world is singularly wanting where most needed sometimes, as evidenced by the words chosen to represent those time-saving device, the telegraph and telephone. Why should not the advent of wireless telegraphy mark a new era of propriety and choice as applied to its peculiar nomenclature?

Let us hope that a reaction may soon set in against borrowed words of hybrid origin, and that due regard for exactness of expression may be had in the adoption of the new words which are soon to come into the language.



Current Engineering and Scientific Notes

Abstracts from the Foreign Papers



Pupin Load Coils in Europe.

IN one of the German journals F. Dolezalek and A. Ebeling describe experiments on the application of Pupin's system to telephone circuits. These experiments were carried out by Siemens & Halske, with the co-operation of the German post-office telegraph administration, and the results were so favorable that the German firm named has undertaken the development of Dr. Pupin's European patents. In concluding their paper, the authors assert that the experiments prove that by the insertion of inductance coils in telephone circuits in the manner described by Pupin the great advantages theoretically claimed are obtained in actual practice, and that a new field is now opened for a wider extension of telephonic intercommunication, for even the problem of transatlantic telephony might be considered as within the bounds of possibility; but, unfortunately, the cost would be excessive, and the technical difficulty of the construction and submersion of a cable with added inductance coils in such great depths must be considered as lying outside the realms of practicability, though the shallower waters, as the North Sea and Baltic, the laying of such a cable may be deemed to be not utterly impossible, thus securing direct communication between London and Berlin and between Berlin and Copenhagen.

Electricity, Petroleum, and Acetylene for Lighthouses in Foggy Weather.

(The Electrical Review, London.)

We mentioned some time ago that an acetylene light had been erected at Altenbruch, on the Elbe, as to which complaints were made by sailors that it did not penetrate so well through mist and fog as did a petroleum light close by. As it is well known that the best fog penetrating light is one of a reddish tint, the suggestion has been offered that the acetylene light should be tinted red by suitable glasses. But a red light cannot be made by colored glasses; red glass does not create red light, it only acts as a filter, straining out (roughly speaking) all the rays which are not red in the original flame, and passing only the red residue. Now, since every source of industrial light is more or less white in tone, it contains rays of every wave length; and therefore when a colored glass is put in front of it, every component of the light is wasted by reflection back into the lantern, by absorption into the body of the glass, and by ultimate manifestation as heat, except the aforesaid red. Accordingly, however fearfully and wonderfully the glasses may be constructed, the issuing light is only equal in volume to the red rays naturally produced in the flame. Monochromatic flames of various colors are known to our chemists—a flame containing the vapor of calcium or strontium is red, more or less pure; but, unfortunately, these lights have not

proved capable of employment on such an enormous scale as is necessary in a lighthouse. Hence, as we cannot at present manufacture directly a pure red light on a commercial scale, it follows that the best source of illumination for foggy weather is one originally as rich as possible in red rays among its other constituents; distinguishing color apart, there is no object in putting a red glass before it with the idea of increasing its penetrating power—that power is not increased by such treatment. We really want to know which light emits the highest candle power, measured in red rays only, for the same amount of money. In practice, as we have said already, the whole question is complicated by the desire of mariners to have here a white, there a green, and there a red light, although the former are more extravagant in foggy weather and the first tends to become reddish when shining through atmospheric moisture. Again, when powerful, long-distance lights are required, a rather intricate arrangement of reflectors and refractors is rendered necessary; and not only do these apparatus become more expensive in a higher ratio than that at which their diameter grows, but also the difficulties of making and keeping them optically perfect increases with the size of the flame. Actually, then, in the construction of a lighthouse to give a powerful beam in all kinds of weather, two opposing factors have to be reconciled as well as may be: the lantern itself asks for a minute extremely intense source of light; the fog demands a large, relatively low temperature light of small intensity per unit of area.

Light Telephony.

A very interesting account of some experiments with "light telephony" is given by Ruhmer, in which he claims to

have succeeded in establishing good communication over a distance of nearly four and one-half miles. The principle followed by the experimenter is this: At the transmitting end the sounds spoken into a microphone generate variations of the current, which are superposed on the direct current from a storage battery feeding an arc lamp. This gives the phenomenon of the sparking arc, and the light intensity of the arc lamp follows the vibrations. The vibrating light rays are made parallel by a parabolic searchlight reflector, and transmitted to the receiving station, where they fall upon a reflector in the optical axis, of which there is a cylindrical selenium cell. This cell is connected in series with a battery and two telephones. If the selenium cell is sensitive enough the transmitted sounds are reproduced. It is necessary to use such a current at the transmitting station for feeding the arc lamp that the illumination of the selenium cells is at the point of its maximum sensitiveness. He uses 4 to 5 amperes for transmission over $1\frac{1}{4}$ miles, 8 to 10 amperes for $2\frac{1}{2}$ miles, 12 to 16 amperes for $4\frac{1}{4}$ miles. The greater the distance the more light is needed at the transmitting station, in order to keep the illumination of the selenium cell at the most favorable point. Mr. Ruhmer finds that the relatively short wave-lengths of the spectrum are the most active in the phenomenon of the "sparking light." The construction of the selenium cell is the principal matter, and he claims that his cell is at least as good as the one used by Simon, which has a resistance of 533,000 ohms, and is reduced to 26,000 ohms with an illumination of 400 lux. Thin layers are used in the cell. After having been illuminated the original resistance, which corresponds to darkness, is reproduced within a few minutes. The experiments were made on the Wannsee, and are said to have given satisfactory

results, and Mr. Ruhmer thinks that light telephony has a practical future in naval and military evolutions.

We quote the above description from a paper in "Electrotechnische Zeitschrift."

A Town Heated by Electricity.

(*L'Electricien, Paris.*)

Electric heating has such advantages over the use of fuels for this purpose that it has been decided to heat in this way the sanitariums of Davos-Platz and Daive-Dorf in Switzerland. A study of the locality has shown that sufficient water power can be had, and this article contains a discussion of the probable consumption of energy for heating, cooking, and other work at these establishments. The principal reason for adopting this system was to avoid all smoke or contamination of the air in this locality. The two settlements cover a district about three kilometers long and from 300 to 400 meters wide. There is about 3,000 fixed population, and during the winter, 2,500 patients. The heaters are of two types, the first being merely a resistance covered by a suitable enamel. The second type, which is used principally for cooking, consists of a small alternating current transformer which induces local currents in the base of the cooking utensil itself. The estimates of the energy required for the whole settlement allow 185,000 horse-power-hours for heating, and 53,600 for cooking. In addition to this, 9,550 horse-power-hours for bakeries, 15,000 for the laundries, and 5,000 for the baths are allowed, making a total of 268,150 horse-power-hours per day of winter. Dividing this by 24 shows that the installation

should have a capacity of 11,200 horse power. These figures are criticised by Mr. A. de Grandmaison, who goes on to show that the estimate for cooking is very much too high. That for heating the buildings gives about 253 watt-hours per cubic meter of apartments, and is assumed to be correct. The results obtained at the restaurant during the exposition of 1900 show that an expenditure of about 450 watt-hours per meal was sufficient. The conditions existing at Davos are less exacting than were those at the exposition. It is thought that an allowance of 1,250 watt-hours per day per person would not be far from the truth. Assuming this figure, the total as given above will be reduced to 228,000 horse-power-hours, and a plant of 9,500 horse power should be sufficient. This power can be obtained from two streams—the Landwasser and the Albula, situated at about 20 kilometers from Davos, and having a fall of 394 meters. The central station will contain five sets of 3,000 horse power each. Each turbine will be coupled directly to two three-phase alternators of 1,500 horse power each. The alternators generate a potential of 8,000 volts, and two being coupled in series give a pressure of 16,000 volts, which is sent out over the line. The annual expenses of this service, including interest, depreciation and cost of operation, is estimated at 829,528 francs. The consumption of energy for the year will be 25,000,000 kilowatt-hours, so that the price per kilowatt-hour will be 3.3 centimes. This cost is not regarded as excessive for heating, while the advantages of its use for cooking, and the avoidance of all smoke are more than sufficient to warrant the undertaking.



With Our Foreign Consuls



Opening for American Enterprise in Italy.—Consul Richmond Pearson, of Genoa, says:

American elevators, if once introduced here and elsewhere on the continent, would quickly and surely supplant the cumbrous, uncertain, and inefficient machines turned out by the factories in Milan and in various parts of France. The houses in this city average seven stories in height. Elevators are greatly needed; the few that are installed were purchased in Milan, and the contrivances are almost comically defective. They take passengers upstairs at a snail's pace, and cannot bring them down at all.

Opening for an American House in Bangkok.—An American business man, who is well acquainted with trade throughout the Far East and has carefully studied this particular field, says that the electrical development of the city of Bangkok during the last ten years has been wonderful. The Siam Electricity Company, Limited, has a capital of \$729,975, plus 200,000 picals (\$100,000 Mexican, or \$46,000 in United States currency). It has 17,000 lamps of 16 candle power, a tramway track of 11 miles in operation, and 40 cars in use and others under construction; it is supplying electric power for various industries throughout the city, and is considering a line of automobiles to be run in connection with its tram line. The manager is now in America on business for his company. A request for another concession on the other side of the river

is being pushed, and there are 26 private plants in the various mills, forts, and dock companies, and in the navy yard of the city. The United States controls the market in this line now, and, with intelligent management, this trade could be greatly increased. In this connection the following table will be of interest, but it must be remembered that a large part of the goods therein credited to England and some credited to Germany are ordered from America through English and German houses who are represented here through their agents:

Electrical Goods and Apparatus Imported from July 1, 1901, to June 30, 1902.

Country whence imported.	Quantity Pack-ages.	Value.
United States....	435	\$61,746 *\$28,403
England	176	34,041 15,639
Germany	103	13,915 6,401
Italy	3	304 138
Singapore	25	4,873 2,242
Hongkong	2	216 106
Total	744	\$115,095 \$52,949

Oil Motors in Japan.—Consul W. T. Fee, of Bombay, sends an article from the "Indian Textile Journal," of that city, from which the following extracts are taken:

"There has been much talk in India during the last year or two of the oil

*Taking the mean value of the Mexican dollar as 46 cents.

motor, but apparently the question is a difficult one. In a city like Bombay, badly served as it is with electric power, an inexpensive motor, giving just sufficient power for installation of electric light, would be invaluable. In a very short time there will be received in Bombay a consignment of small kerosene-oil motors.

Repairing Aerial Wires by Automobile in France.—La Compagnie de l'Est Parisien has recently had constructed an automobile, capable of carrying six workmen and 500 kilograms (1,102.3 pounds) of material, for the purpose of repairing its aerial wires. The platform of this vehicle when raised can

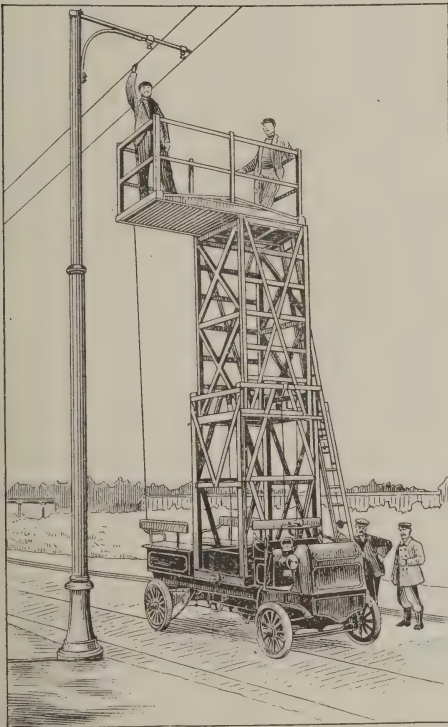

Automobile Repair Outfit.

support two workmen at the height of 6 meters (19.685 feet) and allows them to work without interfering with the passage of tram cars, the platform being changeable either to the right or left

side. With this machine, 10 to 12 kilometers (6.21 to 7.456 miles) of wire can be attended to in one hour. The motor of this vehicle is horizontal with two cylinders. It is of 12 horse power and is placed in front. The illustration shows the apparatus open; when closed, the height is that of the lowest section. The railings of the platform fold down. The "Automobile Revue," of Paris, gives figures as to the economical superiority of this device over that of animal traction, from which it appears that the former is 50 per cent. cheaper than the latter

Railway Contract in Portuguese East Africa—Consul J. H. Thieriot, of Lisbon, under date of December 13, 1902, sends a translation from the "Official Gazette" announcing the approval of a contract between the Portuguese Government and Robert Williams, an Englishman, for the construction of a line of railway 1,400 kilometers (870 miles) in length through the province of Angola, starting from the Bay of Lobito, on the Atlantic coast. A guaranty of 560 contos of reis (\$420,000) has been deposited. The government concedes the right to the grantee for ten years to exploit all minerals within an area of 120 kilometers (74.5 miles) on either side of the line. The railway, it is noted, will work a financial transformation in the province of Angola and make Lobito a port of the first class and the key to central African trade. There is no absolute concession of land nor any immunity from taxes in the terms of the decree.

Demand for American Machinery at Quito.—Under date of December 1, 1902, Minister Sampson, of Quito, writes that a company is being formed in that city to build a large cotton mill. The preference is for American machinery

and looms, and the request is made that firms interested, particularly the North-up Loom Company, send as soon as possible their catalogues and price lists to Minister Sampson, care of the State Department, Washington. European agents are already bidding for the contract, which will not be let until American catalogues and price lists have been received.

Traveling on the Siberian Railway.—Consul S. S. Lyon sends from Kobe the following from the Kobe "Herald":

Prof. C. M. Lacey Sites, who recently returned to Shanghai from America by the Siberian route, writes:

"Rail connection is now complete to Port Arthur, except for the steamboat trip of five hours across Lake Baikal, and the trains run close to the wharves on both sides of the lake. From Irkutsk eastward the old line is followed to a point somewhat east of China. The new line, branching to the south, enters Manchuria territory, and brings up at a station called Manchuria. Here the Russian railway proper ends and the Chinese Eastern Railway begins. The main line of the Chinese Eastern Railway strikes eastward, directly across Manchuria, to reach Vladivostock. At Harbin, however, the South Manchurian line diverges to the south through the rich valley of the Sungari and so to Port Arthur.

"Coming eastward it requires, by the daily train, nine days from Irkutsk to Port Arthur. This period is divided into three fairly equal sections by the division points, Manchuria and Harbin, where change of cars must be made and new tickets bought. There is a 'train avec restaurant' which runs at present once a week, making better connection, but as yet it is only scheduled to run between Irkutsk and Manchuria. Between Ir-

kutsk and Moscow the through trains run only twice a week. It is therefore, necessary to plan the connection or to allow for delay. My schedule of time was as follows: Berlin to Moscow, two days; Moscow to Irkutsk, eight days; Irkutsk to Port Arthur, nine days; add for connection one day; total necessary, 20 days; add, for through trip, London to Berlin, two days, and Port Arthur to Shanghai, three days; total, London to Shanghai, 25 days.

"The service is an all-the-year service, and the ice-breaking steamers on Lake Baikal are supposed to keep up constant communication, but, of course, delays would be more serious in winter travel.

"Between the Irkutsk and Manchuria stations one can travel 'first class,' although this means here about the same as second class in European Russia. Crossing the desert between Manchuria and Harbin one finds the worst accommodation of the line. A third-class coach is labeled second class and reserved for first-class passengers. The 'differential' in the price of tickets does not soften the seats, but it improves the society. The coaches are of medium size, and have only one pair of wheels at each end; this fact, with the paucity of springs, aggravates the roughness of the road. The seats, as in all transcontinental trains, run crosswise of the coach, leaving a passage way at one side, running the length of the coach. The two seats facing each other in each compartment, together with the two upper bunks which can be put in place, are amply broad and long for single beds. Of course, the traveler must provide his own bedding.

"From Harbin to Port Arthur there are, although no first-class, genuine second-class coaches of the omnibus type—that is, the compartments are not closed in, but the partitions extend above

the upper bunks, and a party holding four tickets (usually three, or even two will suffice) can secure privacy by tacking up a steamer rug, or something lighter, across the open end. From Harbin south, for a day's journey, the track is the newest and roughest of the whole line, so some jolting must be expected. The entire Chinese Eastern Railway is so recently built—being, in fact, not yet formally open to traffic—that the ordinary traveler must be prepared to 'rough it.'

"Long stops and plenty to eat, of fair quality but poor variety, may be predicted of the whole route east of Irkutsk, excepting one or two stretches of desert. However, everybody will find comfort in carrying a basket, with an auxiliary supply. Fruit and butter are almost unknown terms in Siberia and western Manchuria. The basket should contain at least jams and jellies, butter, tinned biscuit, lemons, sugar, tea, coffee and cocoa, with an ample supply of napkins, for there is no chance to wash linen and much need to wash the enameled plates and cups which must also be carried, not to speak of knives, forks and spoons. The one characteristic and indispensable requisite of the trip remains to be mentioned—a teakettle. Everybody has need of it, whether he go himself to draw boiling water from the vat which is found at every station, or whether he send his servant to do it for him. A small lamp or candles will also be found serviceable; the train in these eastern parts is illuminated only with candles,

and these are distant and dim. Wash basins will be found convenient, besides the usual toilet outfit.

"These observations do not apply, for the most part, to the road west of Irkutsk, especially if one travels first class. The through trains there are provided with dining cars. Even there, however, it is quite possible to make use of a lunch basket ad interim. Going west, it would be safer to provide the staples at Shanghai; but if there be time at Port Arthur, a first-class stock of European and American supplies can be found there.

"West of Irkutsk, and in northern Europe generally, second class is good enough for anybody. In the rougher regions of the East one will naturally choose the best accommodations to be had. In the following summary, the figures for rates west of Irkutsk include the extra charges for sittings or sleeper; east of Irkutsk there are none such:

From—	—Rates— Rubles.	
Berlin (via St. Petersburg) to Moscow (second class).....	56	\$28.84
Moscow to Irkutsk (second class)	81	41.72
Irkutsk to Manchuria (first class)	26	13.39
Manchuria to Harbin (second class).....	20	10.30
Harbin to Port Arthur (second class).....	22	11.33
Total Berlin to Port Arthur..	205	\$105.58
Food, 20 days, says.....	60
Hotel rooms en route.....	10
Total necessary expense.....	275	\$141.63
Add for through trip:		
London to Berlin (first class), say	50	25.75
Port Arthur to Shanghai, say	35	18.02
Total London to Shanghai... 360		\$18.540





Digest

Engineering Literature of the Month



Power.

By *William O. Weber.*

(*Science and Industry.*)

IT seems to the writer that not enough attention is paid to the subject of the particular kind of power best adapted to any particular factory or class of manufacture. Not enough study is given to the requirements which different classes of factories make in the way of power demand.

A cotton mill is supposed to run practically all of its machinery continuously for 10 hours per day, or, as is usually the case, $10\frac{1}{4}$ hours every day but Saturday, and five and one-quarter hours on that day, making a total of 54 hours for the week's work. It is probably not generally well known that only about 90 per cent. of all the machinery in a cotton mill is in operation continuously, so that the output of the factory is usually not much above 90 per cent. of the theoretical output. Still, the large percentage of steady running in a factory of this type leaves less opportunity to make economic gains by the introduction of electric drives and the splitting up and individualizing of motors; so that, given an ample waterpower and an available mill site directly adjacent to the waterfall, the shafting and belt-driven textile factory operated by water power still represents one of the most economical applications of nature's power forces to the industrial arts.

A shoe factory, however, makes a distinct departure from the above type of

power application, where not over 75 per cent. of the machinery is producing during average working hours; and, if different classes of shoes are made in the same factory, there will be seasons of the year in which whole sets of machinery will remain idle for weeks at a time. In this case, therefore, it becomes pertinent to apply individual motors of some type to short lengths of shafting driving sets of machinery.

A still further change is noted in metal-working establishments. A manufacturing machine shop, for instance, where the machinery is only producing six-tenths of the time, and where it is often advisable to operate each tool with an individual motor.

And, still further along, a wood-working establishment, where the tools are only producing three-tenths of the time, and there is almost no question as to the advisability of individual motor drives.

The writer has used the term motor, not always having in mind, however, an electric motor, as he believes that a great deal of the economy which has been arrived at by the use of individual electric motors can be very closely approximated by the use of individual steam or compressed air motors. There are quite a number of small steam motors which are quite efficient, and it is very noticeable in factories abroad how the use of small steam engines driving different parts of factories, instead of their being coupled to one main

LIBRARY
OF THE
UNIVERSITY of ILLINOIS

THE usual method for detecting Grounds in a two-wire system is to connect two lamps in series across the bus bars of the switchboard. The lamps are generally, but not necessarily, located on the switchboard. A connection is made between the two lamps, which is known as the Ground Connection, as shown in Fig. 1. It is often the case that this simple method of detecting Grounds in a wiring system fails for the reason that the Ground Wire is not properly connected. If often happens in an isolated plant that the different

connected, and consequently connecting to only one system of pipes a Ground will not be indicated if it occurs between the wiring piping system; and consequently this Ground Wire should have a connection to the water piping system, gas piping, steam piping and the sheathing of any lead cables which may be installed throughout the building. Again, this Ground Connection should be carefully made to the various piping systems. The following

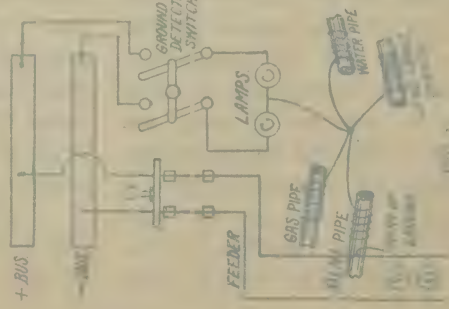

solid or a No. 12 Stranded Ground Wire should be used, but a good suggestion would be to use a No. 12 Stranded Ground Wire. The reason for this is that the No. 12 Stranded Ground Wire is more flexible than the solid wire and will not break so easily. It is also more resistant to corrosion. The No. 12 Stranded Ground Wire is available in lengths of 100, 200, 300, 400, 500, 600, 700, 800, 900, and 1000 feet. It is also available in different colors. The No. 12 Stranded Ground Wire is a good choice for ground detection in a wiring system.

water so it will not eventually corrode this connection and would insulate this connection. Water pipes containing water should be drained before the soldering is done, as sufficient temperature cannot be obtained to run the solder and make a good joint. Another method in the case of water pipes is to tap in a blank plug or stud, as shown in Fig. 2, or a sleeve or sheet copper or cast iron can be used for this connection. By amalgamating the iron pipe and inside surface of the sleeve, the usual form of this connecting clamp is shown in Fig. 3. Never use brass for this clamp, as the mercury combines with the zinc and the brass and rots it.



pole button switch, as shown and connected in Fig. 4. The usual practice is to normally leave the lamps off. When the switch is closed, and there is no ground on the system, the lamps will both burn at the same, and about half candle power.

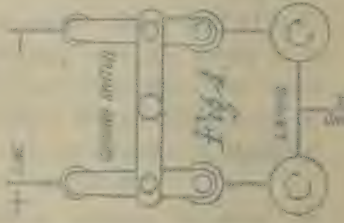

When one Wire of the two wires is grounded with any of the piping systems, one lamp increases in brilliancy and the other fades. The one that fades in candle power is connected to the side of the system that is grounded. The reason of this is that the lamp which is connected to the side of the system which is grounded will have a higher voltage across it than the lamp which is connected to the side of the system which is not grounded. The lamp which is connected to the side of the system which is grounded will have a lower voltage across it than the lamp which is connected to the side of the system which is not grounded. The lamp which is connected to the side of the system which is grounded will have a lower voltage across it than the lamp which is connected to the side of the system which is not grounded. The lamp which is connected to the side of the system which is grounded will have a lower voltage across it than the lamp which is connected to the side of the system which is not grounded.

engine, has been adopted. In Paris the use of individual air motors is a very common practice, and in Germany the use of individual gas engines is nearly as well developed.

Recent developments in the direct compression of air by falling water, from which a very much larger net effect can be obtained by means of preheating and premoistening before using in motors, and the possibilities of distributing perfectly dry, cold compressed air long distances without serious losses will in the near future bring the use of individual air-driven motors into greater prominence. Few people seem to realize the variation in cost of the different kinds of power, and think that all steam power costs about \$23 per horse power per annum, whereas the average cost of steam power in small factories is probably \$65 per horse power per annum. Water power only costs from \$5 to \$10 per horse power per annum. To bring some of these figures down to smaller units the usual cost of steam horse power for 308 days per annum, 10 $\frac{1}{4}$ hours per day, coal costing \$3.50 per long ton, is 1 $\frac{3}{4}$ cents per horse power per hour, and, on the basis of 365 days, 24 hours long, is only nine-tenths of 1 cent.

A gas engine using 20 cubic feet of 760 B. T. U. gas per brake horse power per hour, gas costing 75 cents per 1,000 cubic feet, would make the cost per horse power per hour 1 $\frac{1}{2}$ cents.

Gasoline engines using one-eighth of a gallon of 74 degrees gasoline per brake horse power, gasoline costing 12 cents per gallon, would equal 1 $\frac{1}{2}$ cents as the cost of horse power per hour.

A cost of 1 $\frac{1}{2}$ cents per horse power per hour for electric power is extremely low, and could only be obtained from large installations. Small plants operated by steam should not expect to pro-

duce electric power for much less than 2 $\frac{3}{4}$ cents.

There being such differences; therefore, in the cost and application of power, it readily becomes an obvious question as to the type and application of power to be made for any given factory. This depends so much upon the location, nature of the business, and nearly a dozen other features, that no universal rule can be laid down. An individual study should be made of each plant. Such a study and a report on the peculiarities of the particular plant would invariably pay for itself a handsome return, especially if the recommendations were carried out in full.

Our greatest trouble in this country seems to be that we are inclined too much to copy that which has been done by our neighbors, and not to study the individual necessities of the particular plant under consideration. There is not the slightest doubt in the writer's mind that what is best for one plant is sure to be about the worst for the next adjoining one, and he is equally sure that there is a fad and fashion as to the forms of power to be used, similar to that in the wearing apparel of the fair sex.

In a subsequent article the writer will attempt to show some of the methods of measuring power by different forms of apparatus.

What Oil Does.

What is the annual consumption of oil? It reaches the respectable total of 630,000,000 tons, of which 170,000,000 is consumed in the United States, 148,000,000 by Great Britain, 74,000,000 by Germany and 38,000,000 by France. As 500 grammes of oil (1 1-10 pounds avoirdupois) produces an energy of one mechanical horse power, and as this equals in continuous effect the efforts of 21 men,

it follows that the consumption of oil by the entire world permits of a power development of 1,238,000,000 horse power, which equals the work of 26,000,000,000 men.—*The Car.*

The "Wireless" in France.

The future of wireless telegraphy looms large upon the horizon, said "Booming" being due to the fact that it has become a Government monopoly in France. Now, when anything in the nature of a scientific discovery, tending to improve the social and commercial status of the world at large, becomes a Government monopoly, it is a pretty sure sign that that particular discovery has a future before it, and, further, that its otherwise rapid progress toward ultimate perfection has been, for the nonce, strangled. Coming back to the case in point, it appears that some time ago an official intimation was published in several French papers to the effect that correspondence by wireless telegraphy was a State monopoly, and that no individual or corporate body could establish a wireless telegraph service without first obtaining permission from the Government. Notwithstanding this public intimation, M. Victor Popp, a well-known engineer, formed a private enterprise, with himself at the head, and commenced the installation of a sending and receiving station at Cape la Hogue. The police thereupon intervened, seized the plant, and an official inquiry has been instituted, with a view to preventing further progress in wireless telegraphy on the part of M. Popp and his colleagues.

M. Jioconnau, the manager of the company, stated that the affair has arisen out of a misunderstanding on the part of his company of the formalities necessary in obtaining official consent to the scheme. The contraband station was of an experimental nature, executed with a

view to communication with Cape Grinez and steamers passing up the channel and the Straits of Dover. He further asserts that his company have already erected several stations in Paris without State interference, and that, moreover, Ministers have more than once made use of them for purposes of communication. However that may be, the coherers, relays and other necessary impedimenta at Cape la Hogue have been disconnected and officially sealed, thus insuring a state of quiescence until the matter has been investigated by the Parisian powers that be.—*Electricity (English).*

Double Safety Valve.

The double safety valve shown by illustration herewith, and described in a recent issue of the London "En-

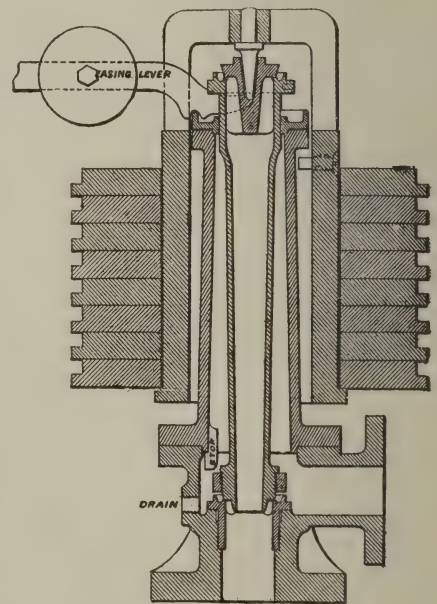

Double Safety Valve.

gineering," was devised with a view to reducing the enormous amount of dead weight required for safety valves of high pressures, particularly for water-tube boilers. The feature of novelty is the arrangement for counterbalancing the weights of the inner

brass tube. It is carried in a fork at the end of a lever, which, at its other end, carries a counterweight which can be adjusted along it to insure that the inner tube follows the upper valve. The lower end of the tube is open, and has a valve surface around it corresponding to a fixed seat in the main casting. The upper end of the tube, which is of larger bore than the lower end, is closed by dead weights in the usual way. The steam pressure tends both to raise the tube and the upper valve, but the upper valve, owing to its larger area, would naturally lift first. The tube, however, follows it simultaneously, and is held against the upper valve by the counter-weighted lever and, also, of course, by the steam pressure on an area corresponding to the upper valve seat. Steam then escapes at the lower valve seat. If, however, the steam pressure is sufficient to raise the lower valve until the ring around the tube meets the stop, the tube can no longer follow the upper valve, which then opens and affords a second outlet. The two valves are quite independent of each other, and if either should stick it will not affect its fellow. The makers have found it an advantage to contract the lower end of the tube, making the outlet sufficient to discharge all the steam possible to be generated with a consumption of coal of 25 pounds per square foot of grate area. The safety valve requires only a single pipe for the emission of the waste steam.

Electricity in Dentistry.

In surgical dentistry when the desire is to suppress the pain of the operations, chloroform, ether, cocaine, freezing, etc., are unsatisfactory because of the danger of their use or the insufficiency of their effects. Practitioners have for a long time sought a method which would produce insensibility of the part and also be

rapid, efficacious and inoffensive, and now the problem has just been solved by M. Regnier, head of the laboratory of electro-therapy of the Charity Hospital, Paris, and M. Dydsbury, says a writer in "La Nature."

The method followed by the two experimenters is the following: By means of a simple conductor they place an arrangement of M. Gaiffe's in connection with an electrode applied to the region to be anaesthetized, the electrode being fashioned of a molding in clay, rendered a perfect conductor by an interior covering of metallic powder and a thin sheet of tin. To absorb the heat produced by the current this last sheet is covered with a layer of humid amianthus paste. The arrangement of M. Gaiffe is composed of a coil with a thirty centimeter spark, a Contremoulin interrupter and petroleum condenser joined to a Oudin resonator. A galvanometer placed on the course of the conductor uniting the resonator and the electrode discloses at every moment the intensity of the current passing into the body of the patient.

Thus disposed, the apparatus is set in motion, and the patient is submitted for several moments to the action of the current. When this has operated, insensibility is accomplished and the operation may be proceeded with. The results obtained by this method are very encouraging.

The Engineer as a Financier.

Whatever the engineer may be called upon to do, he is finally judged successful or unsuccessful accordingly as the task undertaken by him more or less effectively contributes to the securing of a profit in the commercial operation in which his work finds place. It is always maximum financial result at minimum cost which is sought, and this is really

the engineer's final problem in every case, however great or small the work.

Commercial efficiency and financial gain are measures of production of value by the expenditure of the unit of value. The purpose of seeking commercial efficiency is not the accumulation of actual money, but the provision of stored value which may be utilized in the acquirement of whatever desirable article or form of wealth may, at the time of such utilization of that store of energy, seem likely to best meet the needs or the desires of its possessor. The whole business of the engineer, otherwise and broadly described, is the transfer and transformation of energies in such manner as to most effectively contribute to the wealth of the world in permanent and intrinsically valuable forms. He applies energy derived from a prime mover to the production of iron or steel, cotton or woollen cloths, and the product then represents stored energy in an amount which is always measurable in terms of money as was the energy which produced it, either through transformation, as out of heat, or by transfer, as from a waterfall.

The product goes into the market and brings back to the maker its equivalent, as measured in such energy or in money, a portion of which energy is turned back into mechanism of production, and a portion, if a profit is made, remains in the form of potential energy, as capital, in the hands of the producer, to be used in extending his business, by enlarging production, or to be transferred into other systems of manufacture or exchange. It is, however, just as absolutely stored and potential energy, as is the latent heat of fuel, the stored energy of compressed air, or the content of the storage battery in electrical energy.—*Dr. Robert H. Thurston, in Cassier's Magazine.*

Be a Specialist.

"There is an increasing disposition," says the *Iron Age*, "to enlist the services of the specialist, including under this denomination both consulting engineers and manufacturers who make specialties in machinery. The expert engineer, who is devoting his talents and experience to the attainment of better results in any branch of manufacturing, finds his services in constant demand with those who are making improvements."

There was never a time in the history of American manufactures when so many changes were being made in plants as now. Shops are rushed with work to their fullest capacity. Although such times are the worst possible in which to make extensive alterations, yet to secure greater prospective profits, manufacturers are everywhere remodeling their establishments. The larger the plants the more extensive the improvements.

There are unexampled opportunities for the men who have fitted themselves by study of theory and practice to suggest improvements in machinery and the design and operation of plants. It is the age of the sudden rise of competent men. Many have risen in a very few years from the lowest to the highest positions. For the next few years such opportunities are bound to increase. The industrial world is searching for men whom it can promote.

If a man is ambitious and yet is not rising, there is some good reason for it. Whatever the reason is, he can find it out and remedy it. It lies along one or more of the three lines of lack of character, or enterprise, or education. Men who are not going ahead should examine themselves in regard to these three points, and quickly make good such deficiencies as they find. Only so can they hope for substantial advancement.—*Engineering Review.*

Trade Notes

The Equitable Building, Boston, which was partially destroyed by fire on January 9th, will be entirely rewired by Sargent, Conant & Co., of that city, who had a crew of men at work making temporary connections within twenty minutes after the fire was under control. As an example of modern commercial methods, it may be noted that this company, whose old offices were entirely gutted, was transacting business in new quarters with a complete office equipment, telephone service, etc., in less than twenty-four hours after the fire was extinguished.



The extent to which the aid of electricity is being invoked in promoting comfort and convenience in dwellings is well illustrated by a recent contract made by the Otis Elevator Company to install five electric elevators in a single private residence. In the house which is now being erected at Madison avenue and Thirty-seventh street, New York, for Capt. J. R. De Lamar, the elevator equipment is to consist, first, of a passenger elevator, a servants' elevator and a dumbwaiter—all to be automatically controlled by push buttons within the cars and at the several landings. In addition, the contract calls for a sidewalk elevator for ashes, etc., and an automobile lift for conveying motor cars from the street level to a storage room in the sub-basement.



The Marconi Wireless Telegraph Company, of Canada, the organization of which has been completed in Montreal, will take over the completed station at Glace Bay from the English Marconi company, with the exclusive rights to the use and manufacture of Marconi instruments and system in Canada. The officers of the Canada company are F. C. Henshaw, president; Andrew A. Allan and Guglielmo Marconi, vice-presidents; Beaumont Shepard, secretary. In addition to the officers, the directors are: Rodolphe Forget, of Montreal; John D. Oppe, a director of the English parent organization, and Willard Reed Green, of this city. Messrs. Henshaw and Allan are steam-

ship men. Willard Reed Green said recently, in speaking of the new organization: "A plant will be established in Canada, which will manufacture the equipment necessary for the installation of stations in various parts of Canada. Temporarily the equipment necessary will be supplied by the parent company in England from its works at Chelmsford. An important proposition already under way with the Government and various municipalities and corporations will be the establishment of a series of stations on the lower St. Lawrence, designed to increase the business of Canadian ports by reducing the dangers of navigation on the St. Lawrence River."



The constant growth of the demands for power has made it necessary for the New York Edison Company to make arrangements for new generators, rotary converters and transformers. The Stanley Electric Manufacturing Company has secured, through its New York office, this important contract, which is notable not only on account of the total amount involved, but also because of the unusual size of the units. The first item in the contract is for four 2,000 kilowatt S. K. C. rotary converters. The transformer equipment to accompany the same consists of twelve 800 kilowatt S. K. C. static transformers of the air blast type, and four auto-regulators. As is generally known, the largest rotaries hitherto built are the 1,500 kilowatt units in the Manhattan substations, and therefore the construction of those of 2,000 kilowatt capacity marks a distinct advance in the art.

In addition, the contract calls for ten 1,000 kilowatt S. K. C. rotary converters with thirty 400 kilowatt S. K. C. static transformers of the air blast type, and ten auto-regulators. The above apparatus is to be placed in various substations of the Edison system. Furthermore, the Stanley Electric Manufacturing Company are to furnish three new generating units for the Waterside Station. The machines are to be 3,500 kilowatts, 25 cycles, three phase, alternating current generators, direct connected to engines working at 75 r. p. m.



New Inventions

For which Patents have been Granted



717,567. STEAM BOILER FURNACE. Edward Gibson, Jersey City, N. J. Filed March 7, 1902. Serial No. 97,088. (No model.)

Claim.—1. In a steam boiler furnace, a chamber, e, formed in sections matched together by interlocking vertical ridges in one engaging in corresponding vertical grooves in the next, so as to be mutually sustaining

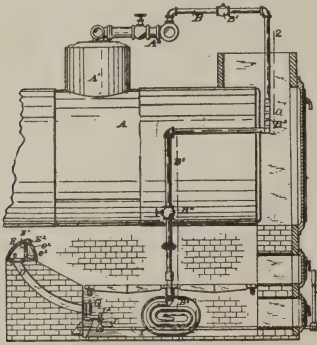

717,567. Steam Boiler Furnace.

and easily removable, and having small perforations, e2, along the front face, in combination with the bridge wall and with gently curved pipes, D, embedded therein, arranged to lead air into the chamber at the full pressure obtaining in the ash pit, and to eject it in a direction opposed to the motion of the gases flowing from the furnace, and with the lip, E2, extending over the perforations; all substantially as herein specified, and nine other claims.

718,076. BATTERY. L. Begeman, Cedar Falls, Iowa. Filed January 7, 1902.

The depolarizing agent is embedded in the meshes of a wire netting arranged around the walls of the cell.

718,083 and 718,084. GENERATING ALTERNATING CURRENTS. C. S. Bradley, Avon, N. Y. Filed June 22, 1896.

718,093. TELEPHONE JACK. H. P. Clausen, Chicago, Ill. Filed May 8, 1902.

718,100. STEAM BOILER DAMPER REGULATOR. Frederick H. Cyrenius, Oswego, N. Y. Filed April 30, 1900. Serial No. 15,025. (No model.)

Claim.—1. In a damper regulator, the combination with a steam boiler, of a casing divided into upper and lower compartments having a passage there between, said lower compartment having an exhaust port therein, a valve normally closing the passage between the compartments, means whereby increase of steam pressure above a predetermined limit will unseat the valve, a weighted arm above the upper chamber adapted to be lifted when said valve is unseated, a second valve

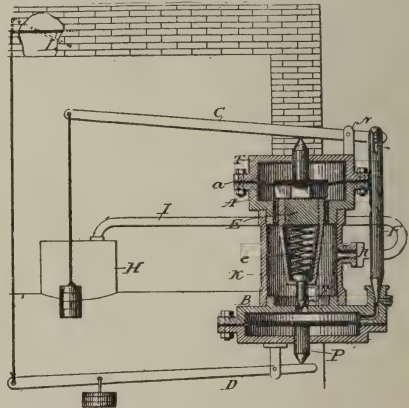

718,100. Steam Boiler Damper Regulator.

adapted to close the exhaust port in the lower compartment and having a stem engaging said arm, a pivoted lever below the lower compartment, and means whereby the unseating of the passage way valve and the seating of the exhaust port valve will actuate said lever, and two other claims.

718,177. CONTROLLER FOR ELECTRIC MOTOR DRIVEN PUMPS. Thomas Trolsen, Brooklyn, N. Y. Filed July 5, 1902. Serial No. 114,449. (No model.)

Claim.—1. In a controller for electric

motor driven pumps, the combination of a pilot electromagnet, two independent contact plates on the core of said magnet, a mercury

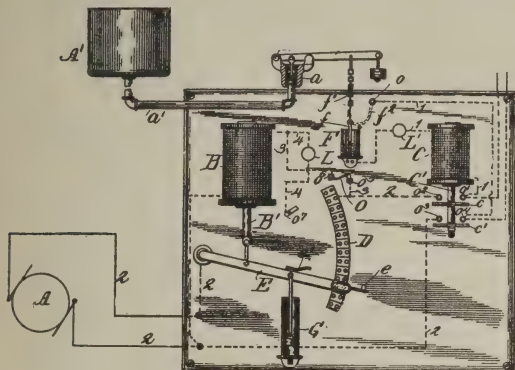

718,177. Controller for Electric Motor Driven Pump.

cup, a contact therefor and means to control the movement of said contact, a circuit including said magnet and cup, a circuit controlled by said contact plates and a motor included in said circuit, and six other claims. 718,182. ELECTRICALLY CONTROLLED ORGAN BELLOWS. E. R. Whitney, Lynn, Mass. Filed June 21, 1901.

A spring is put under tension by the opening movement of the bellows to give a quick movement to the cut-out switch.

718,183. ELECTRIC RAILWAY SYSTEM. G. T. Woods, New York, N. Y. Filed October 30, 1896.

In an electric railway having electro-magnetic track switches controlling the flow of current from the track system to the car motor system, a shunt from the motor system for energizing the magnets of the track switches, and a motor generator on the car having the armature of its motor side in said shunt and having its generator side so connected to the car motor system that the work and therefore the counter electromotive force of the motor generator armature is regulated.

718,205. ELECTRIC BATTERY. M. R. Hutchison, Upper Montclair, N. J. Filed April 5, 1902.

Porous material in intimate contact with the plates projects into a reservoir of free liquid in the bottom of the cell, the top of the cell being sealed and provided with a capillary vent for gases.

718,212. ELECTRO-MECHANICAL MOVEMENT. E. S. Lorimer, Piqua, Ohio. Filed March 8, 1902.

An automatic device for opening the circuit

of a clutch magnet when the driven element has been moved to the desired extent.

718,233. ELECTRIC SIGNAL SYSTEM FOR RAILWAYS. J. W. Williams, Spokane, Wash. Filed May 7, 1902.

A combination of track and wire circuits arranged to operate signaling appliances.

718,235. POLARIZED TELEPHONE SIGNAL BELL. E. E. Yaxley, Chicago, Ill. Filed March 13, 1901.

718,249. ELECTROLYTIC APPARATUS. M. Haas, Aue, Germany. Filed August 6, 1901.

To prevent short-circuiting of the current through the liquid of the cells, the liquid is caused to flow through elongated tubes of small cross section.

718,378. INSULATING LINING AND PROCESS FOR MAKING SAME. G. B. Painter, Schenectady, N. Y. Filed October 6, 1898.

The inside of the shell of a lamp socket is lined with a molded cylinder of sheet fiber.

718,518. ELECTRIC MOTOR. Edwin S. Pillsbury, St. Louis, Mo. Filed July 24, 1902. Serial No. 116,862. (No model.)

Claim.—1. In a motor, the combination with a commutator, of brushes therefor, a short-circuiting device co-operating with said commutator and normally out of con-

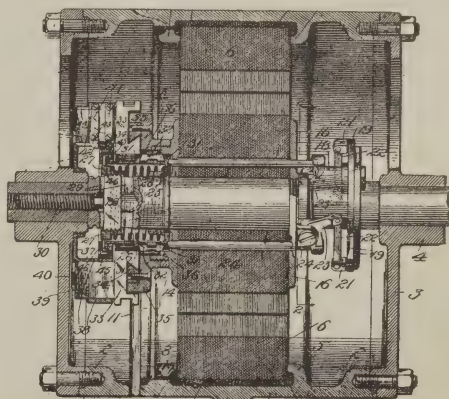

718,518. Electric Motor.

tact therewith, a centrifugal device for moving said short-circuiting device into position to engage the commutator segments, springs for holding the brushes in contact with the commutator segments, and means operated by said centrifugal device for engaging the springs and relieving the brushes of tension; substantially as described, and 21 other claims.



Incorporations and Franchises



CALIFORNIA.

Claremont—Citizens' Light and Water Company, \$75,000. Directors: L. T. Gillet, G. A. Gates, C. C. Johnson, E. C. Norton and L. N. Smith.

San Francisco—United Pacific Power Company, \$100,000. Directors: E. J. Martin, P. J. Miller, H. L. Atkinson, W. S. Burnett and A. H. Winn.

DELAWARE.

Wilmington—The Delaware Electric Company, capital stock, \$1,500.

Dover—The American Public Utilities Company, \$2,000,000.

Wilmington—The Momand Street Lighting Company. Increased from \$100,000 to \$1,000,000.

INDIANA.

Indianapolis—The Hercules Electric and Manufacturing Company, \$10,000. Directors: John A. Kurtz, Albert S. Blackledge, John W. Blackledge, Stewart Kurtz and Frank H. Blackledge.

Indianapolis—The Motor Manufacturing Company has been incorporated to manufacture and deal in motor cars, motors and gas engines. Capital stock, \$50,000. Harold O. Smith is president.

IOWA.

Correctionville—The Home Electric Company, capital stock, \$10,000. Incorporators: W. H. Harter, N. S. Harter, E. H. Baldwin and others.

Brooklyn—Brooklyn Lighting and Heating Company, \$10,000.

MAINE.

Clinton—The Clinton Electric Light & Power Co., capital stock, \$10,000. Promoters: Manley Morrison, Frank L. Besse and J. B. Besse, all of Clinton.

Waterville—Clinton Electric Light & Power Company, \$10,000.

Augusta—The John A. Hamblin Company, \$50,000. Directors: John A. Hamblin, Prov-

idence, R. I.; Joseph Williamson, Lewis A. Burleigh, Augusta.

Portland—The Clark & Mills Electric Company has been incorporated; capital, \$50,000. President, A. W. Tolman; treasurer, Levi Turner, both of Portland.

MARYLAND.

Denton—The Citizens' Light and Fuel Company, \$20,000. Incorporators: William H. Deweese, Albert G. Towers, J. Kemp Stevens, Harvey L. Cooper and Fred R. Owens

MICHIGAN.

Virginia—The Mesaba Light and Power Company, \$25,000. Incorporators: John Castigan, Jr., and John D. Lamont, of Virginia, and Daniel D. Crowley, of Duluth.

MISSOURI.

Kansas City—The Brush Electric Light & Power Company, capital stock, \$100,000. Incorporators: G. Y. Smith, Ed. H. Webster, John T. Peake, of Kansas City; and Dr. Elroy M. Avery, of Cleveland, O.

Terrell—Terrell Electric Light Company, \$25,000. Incorporators: S. E. Noble, M. M. Raley and M. A. Joy.

NEW HAMPSHIRE.

Concord—The Connecticut River Power Company has been incorporated by Brattleboro men, with an authorized capital of \$200,000, which may be increased to any sum not exceeding \$1,000,000. The legislature of New Hampshire will be asked for a similar charter. The company will push the project for a dam across the Connecticut River a short distance below the railroad yard in Brattleboro. It is expected to develop here one of the greatest water powers in New England.

NEW JERSEY.

Jersey City—The Kimmey Electric Light Display Company, capital stock, \$1,000,000. Incorporators: John Kimmey, Ives Horton and Charles A. Stader.

Jersey City—Halsey Electric Generator Company, \$100,000. Incorporators: Henry Halsey, William S. Halsey and Howard H. Williams.

Newark—Montgomery Light and Water Power Company, \$2,000,000. Incorporators: Charles N. King, W. Mondo Greene and Samuel E. Renner.

Camden—The National Electric Purification Company, capital \$1,000,000. Incorporators: William T. Henderson, Harry W. Henderson and C. V. D. Joline.

NEW YORK.

Troy—The Forest Park Railway Company, \$20,000.

New York City—The New York Consolidated Die Company, to act as mechanical and electrical engineers; capital stock, \$100,000. Directors: Abednego Dewes and John Dewes, New York, and R. W. Long, Brooklyn.

Middletown—The National Consolidated Company, to manufacture gas and electricity for villages in Orange and Sullivan Counties. Capital stock, \$50,000. Directors: Charles M. Priggen and G. R. Larwill, Brooklyn, N. Y., and Henry Floy, New York City.

Franklinville—Empire Electric Company, \$2,500. Directors: G. W. G. Ferris, G. E. Spring and R. O. Williams.

New York—The American Electrical Specialties Company, \$50,000. Directors: James Jones, James Jones, Jr., and Julius Silverman, of New York City.

New York—W. R. Ostrander & Company, \$150,000. Directors J. W. Purdy, Jr., W. H. Roberts, C. P. Lashell and I. A. Terrill, of New York, and H. E. Monk, of Flushing, L. I.

Syracuse—The Auburn Subway and Electric Company, increased from \$25,000 to \$100,000.

Rochester—The Rochester Electric Signal Company, capital \$50,000. Directors: W. F. Atkinson, J. G. Kaelber and E. F. Higgins, Rochester.

New York City—The Electric Transit Company has been incorporated at Albany to operate vehicles propelled by electricity or other power in New York City. The capital is \$5,000, and the directors are John Mill, Thomas Steely and Frank E. Taylor, of New York.

New York City—The Austin Light, Heat & Power Company of New York, has been incorporated at Dover, Del., capital \$2,500,-

000. Incorporators: Edward C. Dowling and Harry U. Spence, Brooklyn, and Millard H. France, New York.

New York City—The Ideal Gas and Electric Fixture Company, capital \$10,000, has been incorporated. Directors: Samuel Tepfer and Henry Forendo, Brooklyn; Pin-cus Burger, New York.

OHIO.

Columbus—The Columbian Central Electric Railway, \$10,000. Incorporators: E. J. Miller, D. J. Ryan, Harry R. Young, E. C. Hecox and David H. Pigg.

Cincinnati—Central Electric Company, \$10,000. Incorporators: James Beggs, W. E. Fleming, W. O. Kleine, W. E. Forshee, J. B. Taylor.

Cleveland—The Cleveland Engineering Company, heretofore a partnership engaged in all branches of electrical and mechanical engineering, has been incorporated with \$10,000 capital stock, by H. W. Jones, H. W. Woodward, H. Clay Herrick, C. A. Caldwell and Prof. Charles H. Benjamin. It will continue the business of the old firm on a much broader scale and will devote especial attention to power, lighting and heating systems.

OKLAHOMA.

Guthrie—Central Oklahoma Union Depot and Terminal Railroad Company, \$5,000,000. Incorporators: W. S. McCall, J. C. Trimble, George T. Riehl, L. Underhood, J. J. Collister and W. H. Hottie, of Kansas City, Mo.; J. C. Robb, of Kingfisher, and George M. Thompson and L. M. Thompson, of Oklahoma City.

PENNSYLVANIA.

Philadelphia—The Philadelphia Electric Company, \$100,000.

TENNESSEE.

Memphis—Natchez & Southern Railway Company, \$5,000,000.

Jellico—A company known as the Jellico Electric Light, Heat and Power Company, with an authorized capital of \$12,000, has been granted a charter. The company purposes to establish an electrical energy plant, by means of which sufficient power will be developed to light the city by an improved system, and at the same time furnish lights for mine use and provide power for the use of mills of various kinds. The men interested in the company are as follows: R. B. Baird, W. S. Harkness, W. T. McGuire, S. W. McComb and M. J. Steinberg.

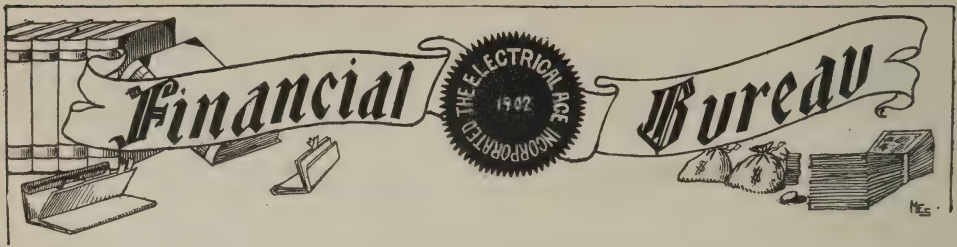

Street railway companies, electric lighting companies and gas companies which desire their reports to appear in the Financial Bureau of THE ELECTRICAL AGE are requested to forward the information so that it may reach us by the 20th of each month. Monthly reports are requested showing gross receipts and when possible operating expenses. Companies are also requested to furnish the highest and lowest prices for which their stock has sold in the market for the previous month.

Street Railway and Other Statements

Companies.	Date.	Gross Earnings.		Net Earnings.	
		1902.	1901.	1902.	1901.
CHARLESTON CON. RY. GAS & E.	Nov.	39,774	42,961	13,516	16,848
Dec.		45,872	60,091	16,508	30,134
CIN., DAYTON & TOLEDO TRAC.	Dec.	36,452	31,117	15,075	13,191
June 1 to Dec. 31.		302,668	146,717
CLEV., ELYRIA & WESTERN.	Dec.	24,710	19,406	8,462	8,309
Jan. 1 to Dec. 31.		300,845	249,259	129,771	112,394
DETROIT UNITED.	Dec.	301,305	271,441	125,002	118,037
Jan. 1 to Dec. 31.		3,473,140	3,039,172	1,505,608	1,354,720
All properties.		3,961,402	1,700,616
ELGIN, AURORA & SOUTHERN.	Dec.	34,999	30,199	12,585	11,620
June 1 to Dec. 31.		257,849	226,630	109,573	105,889
Jan. 1 to Dec. 31.		410,431	361,664	166,779	155,658
ITHACA STREET RAILWAY—					
Oct. 1 to Dec. 31.		17,546	17,166	3,260	6,115
Jan. 1 to Dec. 31.		79,976	78,898	28	12,048
JACKSONVILLE ELECTRIC CO.	Nov.	19,541	7,000
May 1 to Nov. 30.		122,954	39,874
KINGSTON CONSOLIDATED—					
Oct. 1 to Dec. 31.		24,929	10,023
Jan. 1 to Dec. 31.		111,959	47,477
LEHIGH TRACTION.	Dec.	9,552	10,721	4,337	5,898
MADISON TRACTION.	Dec.	7,217	5,505	866	1,494
Jan. 1 to Dec. 31.		79,454	20,966
NEW YORK & QUEENS COUNTY—					
Oct. 1 to Dec. 31.		134,744	113,716	41,272	40,211
July 1 to Dec. 31.		327,443	284,123	144,712	138,823
PUEBLO & SUB. TR. & LT. CO.	Nov.	37,634	23,733	13,286	8,143
TOLEDO RAILWAYS & LIGHT.	Dec.	139,608	126,378	75,719	62,747
Jan. 1 to Dec. 31.		1,459,091	1,311,084	732,312	674,677
UNITED TRACTION (ALBANY)—					
Oct. 1 to Dec. 31.		397,296	364,251	134,813	104,809
July 1 to Dec. 31.		783,497	747,228	269,276	248,816

Massachusetts Railroad Commissioners.

Annual Report.

According to the annual report of the Massachusetts Railroad Commissioners the electric railways of that State have experienced a substantial growth during the past year, while the steam roads have remained practically stationary. The report shows that the electric roads have not only made

the larger gain, relatively, in mileage, but also in earnings, especially in net earnings. The increases in mileage of the electric and steam roads for the fiscal year ended September 30, 1902, and June 30, 1902, respectively, compare as follows:

Mileage—	1902.	1901.	Inc.	P. c. inc.
Electric roads.....	2,465	2,215	250	11.2
Steam roads.....	2,106	2,107	*1	*0.0

* Decrease.

Thus the State already has a larger mileage of electric roads, and this mileage is growing more rapidly, than that of the steam

roads. Earnings for the period compare as follows:

Gross earnings—	1902.	1901.	Increase.	P. c. inc.
Electric roads.....	\$24,918,684	\$23,179,304	\$1,739,380	7.5
Steam roads.....	86,920,565	82,385,586	4,534,979	5.5
Net earnings—	1902.	1901.	Increase.	P. c. inc.
Electric roads.....	9,005,309	8,614,163	391,146	4.5
Steam roads.....	25,564,744	25,091,995	472,749	1.8

The relatively small gain in the net earnings of the steam roads was owing to the increased cost of materials and labor. In the past five years wages have increased

from 31.2 cents per train mile to 32.9 cents, or 5.3 per cent.; and fuel has risen from 10 cents to 13 cents, an increase of 30 per cent.

COPPER.

The following compilation, showing the production, exportation and consumption of copper in the United States during 1902 has been made by the New York Metal Exchange, 2,240 pounds being figured to the ton:

	1902.	1901.	1900.	1899.
Dom. prod'n.	293,830	266,716	270,588	261,313
Net importations of for'n.	74,927	61,286	38,182	39,858
Total supplies	368,757	328,002	308,770	301,171
“ exp'rt'n	168,435	98,941	156,852	115,594
Estim'd home consumption	203,000	165,000	150,000	162,000
Stks at mines, on transp'tations, at refineries, in warehouses.	133,813	136,491	72,430	70,512

	1902.	1901.
Lake Superior.....	166,000,000	156,289,481
Montana	218,000,000	229,870,415
Arizona	140,000,000	130,778,611
California	40,000,000	33,667,456
Utah	31,000,000	20,116,979
Miscellaneous	62,000,000	31,349,577
Total	657,000,000	602,072,519

The percentage of increase in production over 1901 is 9.1 per cent., which compares with a decrease in 1901 from 1900 of 0.6 per cent. and an increase in 1900 over 1899 of 6.6 per cent. Mr. Stevens estimates the 1902 world's production of copper at 557,854 tons, an increase of 8.9 per cent., and comparing as follows: 1902, 557,854; 1901, 511,803; 1900, 484,852; 1899, 468,423; 1898, 434,023; 1897, 405,350. Mexico is the largest contributor to the past year's increase. The supply of copper on hand at present in the United States is placed by Mr. Stevens at 150,000,000 lbs., or 58,000 long tons.

On the other hand, Horace J. Stevens, Assistant Mineral Commissioner of Michigan, computed the following estimate (in pounds):

Stated Reports of Companies

Boston Elevated Railway.

Supplemented to the balance sheet for the year, printed in the January number, we give

a comparative statement of earnings, expenses, charges etc., for three years:

	1901-2.	1900-01.	1899-00.
Revenue miles run.....	45,999,999	43,824,879	38,353,514
Revenue passengers carried.....	222,484,811	213,703,983	201,124,710
Gross earnings.....	\$11,321,030	\$10,792,993	\$10,141,209
Operating expenses—			
General	655,393	698,046	858,895
Maintenance—			
Road and buildings.....	982,230	877,516	1,022,002
Equipment	871,480	709,335	579,109
Transportation	5,353,469	5,051,700	4,368,104
Total operating expenses.....	\$7,862,572	\$7,336,597	\$6,828,110
Net earnings.....	3,458,459	3,456,396	3,313,099
Other income.....		76,503	95,785
Total income.....	\$3,458,459	\$3,532,899	\$3,408,884
Charges, etc.....	2,836,560	2,896,360	2,932,839
Balance.....	\$621,899	\$636,539	\$476,045
Dividends..... (6 p. c.)	600,000	(5¾ p. c.) 575,000	(4½ p. c.) 337,500
Surplus.....	\$21,899	\$61,539	\$138,545

President William A. Bancroft says: "This report records the full fiscal year of operation of the elevated railway. When account is taken of the difficult conditions under which trains are run in the subway, it is not too much to say that the operation has been highly satisfactory. While the increase in the total number of revenue passengers for the entire system was 4.1 per cent., the increase in the number of persons entering the subway was 14.97 per cent. This enlarged use of the subway is undoubtedly due to the greater efficiency of the elevated road in handling traffic. The number of free transfer passengers is estimated for the year as not far from 113,000,000; in other words, for every two passengers who paid a fare to the company, more than one received a free transfer. During the year the company increased its motive power by putting into service the two large engines spoken of in the last report, each of 4,050 horse power, operating a 2,700 kilowatt generator. One has been installed at the Lincoln power station and one at the Charlestown power station. The extension of the surface tracks during the year has amounted to only 1.4 miles. The total surface track operated is now 393 miles; elevated mileage, 16 miles; total mileage, 409.4 miles. The company has maintained its plant, tracks, cars, buildings and other equipment in thorough repair. The work of enclosing the platforms of box cars is proceeding. There have been added to the equipment during the year 50 cars for the elevated division. An agreement has

been made by which there may be made a lease to this company of all the Old Colony Street Railway tracks within the limits of the city of Boston, except those of Neponset. Agreements have also been made with the Boston & Suburban Companies and the Boston & Worcester Street Railway Company by which the cars of those companies will be taken by our conductors and motormen at our outlying surface terminals, brought to in-town points of our system, and then returned to the points where they were taken. The stockholders at a special meeting held July 25, 1902, voted to increase the capital stock \$5,000,000. The Railroad Commission, however, authorized the issue of only \$3,000,000, making the total capital authorized by law to date, \$13,300,000. The Railroad Commission also fixed at \$155 per share, the price at which stockholders might subscribe. Of this \$75 has already been paid in, and the balance, \$80 per share, is due on January 15, 1903.

On September 25, 1902, a contract was executed between the Boston Transit Commission and this company which provides for the exclusive use by this company of a subway or subways to be constructed by the Transit Commission under or parallel with Washington street. The contract gives the company a term of 25 years from the beginning of use, at an annual rental of 4½ per cent. on the cost. This contract was subject to the acceptance of the act at the municipal election of the city of Boston for 1902. The act has been accepted.

Kings County Light and Power Company

Of the \$5,176,000 purchase money 6s, \$176,000 were assigned to the Edison stockholders' committee, which has sold \$10,000 to meet the expenses of the committee. "These expenses have been paid, and the committee is not now authorized to sell any further bonds, but is limited to the use of the interest of the remaining \$166,000 of said

bonds, which bonds constitute the permanent fund of the said stockholders' committee." The \$10,000 bonds have been listed on the New York Stock Exchange, making the total listed \$5,010,000. The balance sheet of November 1, 1902, furnished to the Exchange, compares as follows:

Balance Sheet.		Sept. 30, 1902.	Nov. 1, 1900.
Assets—			
Property		\$3,253,862	\$3,259,210
Central Trust Company, Trustee.....		1,000,000	1,000,000
Stock in other companies.....		5,175,870	5,175,770
Bills receivable.....		685,000	175,000
Accounts receivable.....		107,168	55,072
Cash in banks.....		11,266	22,085
Accrued interest on investments.....		5,963
Total.....		\$10,239,130	\$9,687,137
Liabilities—			
Capital stock.....		\$2,500,000	\$1,980,000
First mortgage 5s.....		2,500,000	2,500,000
Purchase money 6s.....		5,176,000	5,175,000
Premium on 251 shares sold.....		10,542
Accounts payable.....		337	606
Profit and loss.....		52,251	30,631
Total.....		\$10,239,130	\$9,687,137

Financial Notes

The Louisville Railway proposes to increase its stock \$1,200,000 for interurban lines and betterments.

The stock of the Home Telephone Company, of Toledo, has been placed in a voting trust for five years.

El Paso Electric Company directors declared the first dividend of \$3 per share on the preferred stock last month.

The St. Louis & Suburban Electric Railway has filed a certificate of increase of capital stock from \$3,000,000 to \$7,000,000.

For the month of December, Chicago Telephone Company gained 1,500 'phones. The grand total of telephones in Chicago is 60,400.

The Metropolitan Street Railway (New York) managers raised the wages of conductors and motormen January 18 equal to 5 per cent.

A director of the Electric Company of America says the earnings for last year will be equal to 8 1-2 per cent. on the \$4,000,000 stock.

Application has been made on the Stock Exchange to list New York & Richmond Gas Company \$1,000,000 first mortgage 5 per cent. bonds of 1921.

The gross earnings of the Philadelphia Company and affiliated corporations for December, 1902, were about \$13,000 in excess of December, 1901, an increase of about 10 per cent.

Newark & Hackensack Traction Company, now in the hands of a receiver, is to be reorganized. The securities are largely owned by the Hudson River Traction Company.

At the annual meeting of the stockholders of the Stanley Electric Manufacturing Company February 11 a resolution to increase the capital from \$3,000,000 to \$10,000,000 will be voted upon.

Dallas, Tex., Terminal Railway and Union Depot Company shareholders will vote March 9 on a proposition to make a mortgage securing not exceeding \$2,000,000 bonds for the purpose of necessary improvements, etc.

The Citizens' Telephone Company, of Paris, Tex., has filed a mortgage to the Guardian Trust Company, of Cleveland, Ohio, as trustee, to secure \$150,000 bonds to be issued to pay for extensions and additions.

Lake Shore Electric Railway (Ohio) shareholders will vote Feb. 12 to increase the capital stock \$1,500,000 preferred, to issue \$4,000,000 first mortgage consolidated bonds, and to issue \$7,000,000 general mortgage bonds.

At the annual meeting of the Toledo Railways and Light Company it was shown that the company earned last year 2.27 per cent. on the capital stock, and the chairman of the board estimated that this year's earnings will reach 3 per cent.

Philadelphia & West Chester Traction Company shareholders on January 12 authorized the creation of a mortgage to secure \$600,000 of 4 per cent. 50-year gold bonds, of which \$400,000 will be reserved to relieve the present 5 per cent. bonds.

The Thompson, Tenney & Crawford Company offer at par and interest \$150,000 Shreveport (La.) Gas, Electric Light and Power Company 5 per cent. \$500 gold mortgage bonds, due October 1, 1922, but redeemable at 105 and interest after October 1, 1912.

The Potomac Electric Power Company, of Washington, D. C., controlled by the Washington Railway and Electric Company, has filed a mortgage to the Commercial Trust Company, of New Jersey, for \$2,500,000, of 4½ per cent. gold bonds, payable January 1, 1923.

E. H. Gay & Co. offered last month at 101 and interest \$425,000 Hudson River Electric Company's outstanding \$2,000,000 first mortgage 30-year 5 per cent. gold bonds, principal and interest guaranteed by the Hudson River Water Power Company, the capital stock of which has recently been increased from \$2,000,000 to \$5,000,000.

The Omaha Street Railway, which was transferred to a New York syndicate early in December, will extend two lines in South Omaha, requiring the construction of probably three miles of double track. A new line to Florence, Neb., six miles north, is

now being built, and a new \$500,000 power house and plant will be built in the spring. A further announcement is made that next year all light rails will be replaced by heavy ones, requiring hundreds of tons of heavy steel.

The increase in Philadelphia Rapid Transit gross earnings for the six months ended December 31, 1902, assuming that half of it, or \$325,000, can be saved in the net, would be equivalent to over 10 per cent. on the \$3,000,000 paid in on Philadelphia Rapid Transit stock. The earnings for the fiscal year ended last June showed a surplus over Union Traction fixed charges sufficient to pay the dividend rental of \$900,000, 3 per cent. on \$30,000,000 Union Traction stock, and leave a balance of \$178,000.

At the annual meeting of the stockholders of the Telephone, Telegraph and Cable Company of Eastern New York, a sub-company of the Telephone, Telegraph and Cable Company, the president reported that the company has operated during the past year a telephone exchange in Mount Vernon, N. Y., with pole lines from the boundary limits of New York City extending easterly. Owing to the non-completion of the connection with New England cities the business is not in as satisfactory condition as it is hoped it will be in the future.

The \$3,000,000 4½ per cent. refunding and real estate bonds of Western Union application, for the listing of which has been made at the Stock Exchange, are part of the \$20,000,000 issue authorized in 1900 to retire certain bonds maturing in that year, and to provide for the cost of new property acquired and new lines constructed, from and after June 30, 1899. The company has for some time been making rather extensive additions to its property, the cost of which is to be met out of these bonds. The number of lines between this city and Chicago has been largely increased.

American and Canadian capitalists, who own the Tramway, Light and Power Company, Ltd., of San Paulo, Brazil, will be interested in the first annual report of the company. Gross earnings (gold) were \$1,121,661; operating expenses, \$420,463; net, \$701,198. Annual interest charges on \$6,000,000 5 per cent. gold bonds amounts to \$300,000, and 5 per cent. dividends on \$7,000,000 stock calls for \$350,000, thus leaving a balance of \$151,198. Net earnings now are at the rate of \$70,000 per month, and business is not up to the limit by reason of delay in getting equipment from the United States.

The Metropolitan West Side Elevated Railroad (Chicago) ends its fiscal year February 28. For the first half of the year a

dividend of 1 1-2 per cent. on the preferred stock was declared. It is stated that the directors at the coming meeting will declare 2 per cent., making in all for the year 3 1-2 per cent. It is said that the company could pay 2 1-2 per cent. as a result of the good year, but that the treasury must be taken care of. Daily average passengers carried for the year will come out about 108,000, against 93,000 for the preceding year. The common stock will be held in a voting trust until February 4, 1904.

The Virginia Passenger & Power Company, recently purchased by Frank Jay Gould and friends, is a consolidation of all the street railway, electric light and power companies in Richmond, Manchester, Petersburg, and surrounding territory, and includes the Richmond Traction Company, Richmond Passenger & Power Company, Richmond & Manchester Railway Company, Richmond & Petersburg Railway Company, Virginia Electric Development Company, Westhampton Park Railway Company, and several other similar corporations. The capital stock is \$15,000,000, and bonded indebtedness the same amount.

The Hibernia Bank and Trust Company (the mortgage trustee) and Stanton & Littlefield, both of New Orleans, offer at 102 and interest \$100,000 Shreveport (La.) Traction Company first mortgage 5 per cent. gold bonds, dated January 1, 1903; due January, 1923, but subject to redemption at 105 and interest five years from date. These bonds are part of a total issue of \$200,000, of which \$50,000 are held in escrow for future extensions and improvements. Interest payable January and July in the City of New Orleans. The net earnings for the year 1902, it is stated, were more than four times the annual interest charge on the present issue of \$200,000 bonds.

In 1900 the Consolidated Gas Company, of New York, was assessed \$36,200,000. They protested, and the tax was fixed at \$2,881,385, but the return showed the taxable balance and surplus to be \$2,992,385. Thereupon the company obtained a writ of certiorari to review the assessment, and, when petition and writ came to be heard before the special term, the assessment was stricken from the rolls. From this the defendants appealed. Although the commissioners' assessments were erroneous they were not illegal, holds the appellate division, and, therefore, according to the statute, the tax cannot be vacated, but must be reassessed.

Harvey Fisk & Sons have issued an interesting circular on the Interborough Rapid Transit Company, incorporated in May last for the purpose of operating the great New

York subway railroad, which, it is expected, will be running this year. The Interborough Company has already acquired by lease the Manhattan Elevated Railway system, which earned for the year ending September 30 last, 6.9 per cent. on its stock. It is estimated by the bankers that the company will earn at the start \$7,500,000 gross per annum, and be operated for about 45 per cent., thus netting \$4,125,000. After paying interest on bonds to the city, there will be a surplus of \$2,830,000, over 8 per cent. on the stock.

It was the first intention to issue the new Macon, Ga., Railway and Light Company securities dated June 1, 1902, but, owing to delay in the cancellation of some of the bonds and mortgages of the companies consolidated, it was decided to issue the new securities dated January 1, 1903, and allow the subscribers to these securities interest from June 1 to December 31, 1902. Under this arrangement the subscribers were paid on January 1 by the Savannah Trust Company, of Savannah, Ga., interest at the rate of 5 per cent. per annum on the subscription to the bonds, and a dividend at the rate of 6 per cent. per annum on their subscription to the preferred stock from July 1 to December 31, 1902. The interest on the bonds will hereafter be payable in January and July, and the dividends on the preferred shares in April and October.

The People's Gaslight and Coke Company, of Chicago, had a very satisfactory year, earning practically 10 per cent. on the stock. On the authority of a director, the statement was recently made that the company has now in service nearly 250,000 meters, or over 25,000 more than at the close of 1901. The increase in gross revenue in a year due to this addition would ordinarily be figured at about \$700,000, but the great scarcity of coal during the last three months has probably made these meters earn at the rate of \$1,000,000 a year. The earnings of these new meters appear to be a clear gain over 1901, as the additional earning power of the 323,000 meters in service at the close of 1901 is thought to have been more than sufficient to care for the increased cost of operation. However, it is not likely that a gain of, say, \$750,000 or even \$800,000 will be allowed to appear in the net earnings shown in the forthcoming annual statement, particularly with an ordinance setting 75 cents a thousand cubic feet as the maximum charge for gas in the city of Chicago now before the courts.

The Mercantile Trust Company, trustee, under the Boston United Gas Company's trust agreement of January 1, 1889, has, at the request of holders of more than one-fourth of the bond certificate issued thereunder, ordered the sale on February 10, at noon, by R. V. Harnnet & Co., at the real

estate salesrooms, 111 Broadway, of the following stocks pledged to secure the bonds, viz.:

Name of Co.	Stock Pledged.	Total Issue.	Total debts June 30, '01.
S. Bos. G. L. Co.	\$438,300	\$440,000	\$170,997
Roxb'y G. L. Co.	599,300	600,000	225,695
Boston G. L. Co.	*2,497,000	2,500,000	733,490
B'y S. G. C., M's.	1,999,300	2,000,000	578,284

The sale is preparatory to reorganization, for which a plan was announced by Kidder, Peabody & Co. last month. The plan provides for the exchange of the bonds for cash and shares of the Massachusetts Gas Companies, first series, each \$1,000, \$250 cash and \$1,000 preferred stock; second series, each \$1,000, for \$670 preferred and \$670 common stock. The Massachusetts Gas Companies voted to increase the capital stock from \$30,000,000 to \$50,000,000.

The increase of capital stock of the subsidiary companies of the American Telephone & Telegraph Company from time to time has aroused interest as to the money requirements of the American Telephone & Telegraph Company for the year 1903. The Cumberland Telephone Company, which operates throughout Tennessee, Kentucky, and other Southern States, is asking authority of stockholders for an increase in its capital stock from \$10,000,000 to \$20,000,000, and as the American Company owns 52 per cent. of the capital stock of that company, it will be called upon to furnish \$5,200,000 of the increase, although the new stock may not all be issued in one year. It is estimated that the telephone companies will require \$25,000,000 in 1903 for extensions throughout the United States and Canada. This sum will put in about 200,000 subscribers and build the necessary long distance lines. Of the \$25,000,000, the minority stockholders of the subsidiary companies will furnish \$10,000,000 and the parent company \$15,000,000. Most of the capital furnished by the subsidiary companies will be through stock issues, although there may be small bond issues.

The Western Telephone & Telegraph shares are now quoted at about 22, which is equivalent to 16 1-2 for its predecessor, the

* Par value of shares, \$500.

Erie Telephone Company, as 100 shares of Erie stock were converted into 75 shares of Western Telephone stock, besides having to pay an assessment of \$25 per share for Western Telephone preferred at par: Erie Telephone shares never sold below 15, and once sold as high as 122 3-8. On the reorganization, \$15,000,000 of money was raised to pay off the construction debts, and put \$6,000,000 more into new construction. The Southwestern Telephone Company, the Northwestern Telephone Company, the Wisconsin and the Cleveland companies are understood to be doing a continually increasing business. The Western Telephone Company owns but 70 per cent. in these and also owns \$3,600,000 stock, \$2,400,000 floating debt of the Michigan Telephone Company, and these assets are problematical. This company was not taken in by the Western when the Erie was reorganized, but was left to future treatment. The Michigan Telephone situation is rather anomalous. The property is hampered by lack of new money and by floating debt. The bondholders know that more than the face of their bonds has gone into the property and is still there. There are \$5,000,000 of Michigan Telephone bonds and \$650,000 of Detroit Telephone bonds. It is understood that these bondholders are willing to buy the property at foreclosure and put up new money for extensions. Expert valuation of the Michigan Telephone property shows \$9,000,000. The problem Western Telephone Company has on its hands is how to finance the Michigan in the future and not carry the whole load. It is proposed that the bondholders shall make some concessions and that the stock interests furnish new money, but the bondholders do not receive the suggestion with favor. They say they prefer to take the property, and there the matter stands. If the Western Telephone Company could realize upon its assets in Michigan or come to some agreement with the bondholders by which new money could safely be poured into the property, Western Telephone shares would have a broader speculative future. It is said that the Michigan Telephone Company is earning its bond interest and a margin of \$100,000 besides, but this is a narrow margin upon which to carry \$2,400,000 floating debt and raise additional construction money.



UNIVERSITY OF LONDON



The Automobile Wireless Telegraph Station.

THE ELECTRICAL AGE

NEW YORK

VOL. XXX

MARCH, 1903

No. 3

The Joint Transmission of Different Currents.—Bedell System

By A. S. McALLISTER

REMOVE an incandescent lamp from its socket, insert an attachment plug connected to a telephone set and talk to your neighbor, while other lamps on the circuit are as brilliant as ever. Operate motors and lamps from the same circuits, the one by direct current at high electro-motive force, the other by low voltage alternating current. Overload the motors until the electro-motive force is reduced to zero value, yet the lamps burn as brightly as ever. Install just enough copper to transmit power to the lamps in use, and then add as motor load of equal value without increasing the amount of conducting material. Send polyphase currents at low frequency for operating motors, and single-phase current at high frequency for lights, over the same transmission circuits, using copper enough for the one

load alone. Allow the electro-motive force of the polyphase circuit to fluctuate greatly while the lamps burn as though they alone were connected to the circuit. Place upon the motors such loads that every circuit breaker in the polyphase opens, yet the receivers on the single-phase system show no sign of disturbance. Add one-third more copper to the three-phase system now in use and transmit fifty per cent. more power than at first at the former percentage of line loss. Such are the feats made possible by the use of the composite system of transmission devised by Dr. Frederick Bedell.

Direct and alternating currents, or currents of different frequencies, when traversing the same conductor, act independently of each other. Neither recognizes the presence of the other. Thus, when a direct current of value I flows

through a conductor of resistance R , the loss is I^2R . If an alternating current of value i is sent alone through the conductor, the loss will be i^2R . Now when the two currents flow together the loss will be only I^2R plus i^2R , or equal to the sum of the two losses found above, and not $(I \text{ plus } i)^2R$, as would be the case were the two currents of like character and phase. This is due to the fact that currents differing in character or frequency have as their resultant a value equal to the square root of the sum of the squares of the separate currents.

The proof of this fact may be made clear by the use of Figures 1 to 3. Let the alternating current of effective value i (Fig. 2), be superposed upon the direct

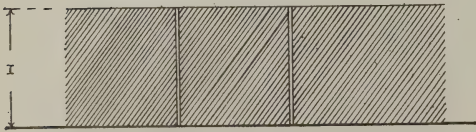

Fig. 1.

current of value I , as shown by Figure 3. Throughout half of the time the line current is greater than the direct current, while during the remaining portion of the time it is less than I . Consider the two instants when the alternating current has values of plus C and minus C , respectively. The line current will be I plus C and I minus C . If the line resistance be R , the mean loss for the two instants chosen will be

$$\frac{(I+C)^2 + (I-C)^2}{2} R = (I^2 + C^2) R$$

or the same as though each current acted alone. This relation may similarly be shown to hold true for all equal and opposite values of the

alternating current. Hence, the effective value of the resultant current will be

$$\sqrt{I^2 + i^2}$$

Further consideration will show that with alternating currents of different frequencies, the same result will be obtained, since for each increment of time when the two currents flow in the same direction there is an equal

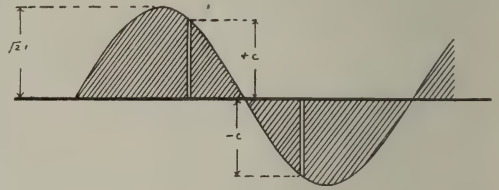

Fig. 2.

increment when each has the same value as before, and they flow in opposite directions, so that the proof given above is equally as applicable to asynchronous, as to alternating and direct currents.

Knowing these theoretical advantages incident to the joint transmission of differing currents, the methods applicable to the utilization of the economy and the independence of flow of the currents are not immediately apparent. A simple

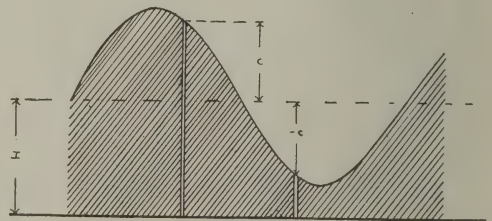

Fig. 3.

method by which these advantages may be secured in practice will now be described.

Figure 4 is a schematic representation of circuits for the simultaneous transmis-

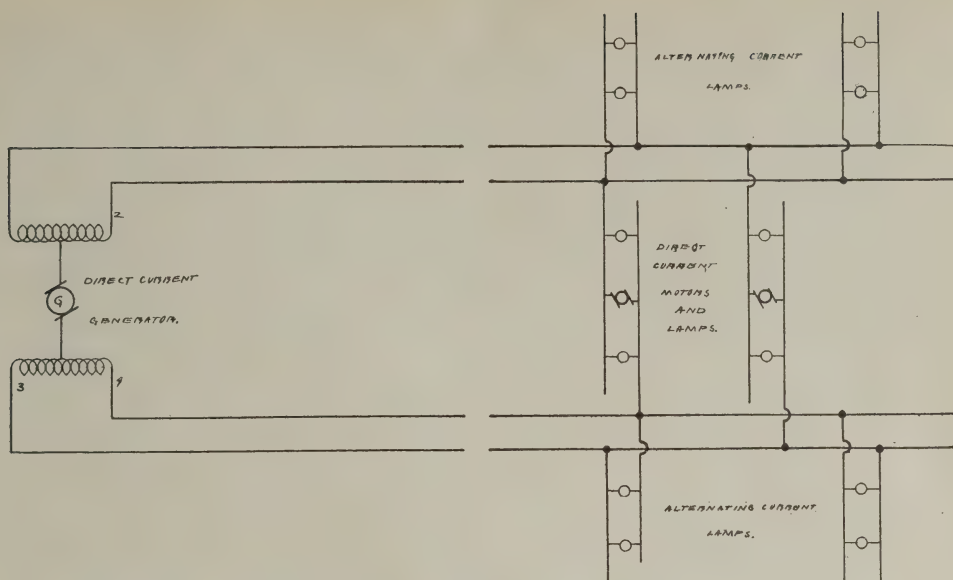

Fig. 4.

sion of direct and alternating currents, each conductor being common to two systems. Alternating current is supplied through the single-phase transformer coils, 1-2 and 3-4, to the corresponding conductors for the operation of incandescent lamps. Direct current is introduced at the neutral points of each transformer coil and passes out through conductors, 2-3 or 3-4, connected between which are the direct current receivers. The alternating electro-motive force is given a value suitable for the lamps, while the voltage of the direct-current circuit is placed at a value dictated by the requirements of the motors of other similar receivers.

The generator, shown in the diagram, may be any convenient source of direct current. Thus, it may be a mechanically driven single or double current generator, a motor-generator set, or a rotary converter operated from power circuits. The transformer coils can be the secondaries of lowering transformers deriving energy from high potential cir-

cuits, or they can be supplied with alternating current through proper devices from the alternating side of a double current generator.

A most interesting and valuable feature of circuits thus interconnected is found in the fact that the receivers requiring current of different character are unaffected, the one by the operation of the other. This is due not only to the inherent independence of the losses occasioned by the two currents, as discussed previously, but also to the peculiar method of interconnecting the circuits. If one traces the path of travel of the direct current to any receiver it will be discovered that the current traverses one section of one transformer coil in a certain direction, and, returning, passes in a reversed direction through a similar section of the other coil. Both coils surround the same magnetic core, and, each having the same number of turns, no magnetizing effect is produced by the direct current. The voltage impressed upon the alternating-current

lamps is determined wholly by the electromotive force of the transformer coils, and the direct-current generator may be overloaded to any extent without causing a fluctuation in the brilliancy of the lamps on the transformer circuits.

As a further study of Fig. 4 will show, it is not essential that four wires be installed throughout all sections of the area of distribution. The main conductors may be erected along any convenient thoroughfare, and branch circuits, each of two conductors, run by way of the various cross streets to the consumer's premises. In locations where both motors and lights are desired only three conductors are necessary. It will be observed, also, that no apparatus other than such as is now commonly in use is required at the generating station, while, as concerns the consumer, no change whatever is needed in the equipment now installed for his service.

For small distributing systems where it is desirable to operate both motors and lights, as, for example, in stores, office buildings and factories, the common conductor method of composite transmission offers many advantages over any method now in use, since even elevator motors or motors for driving machine tools may obtain current from the lighting mains without affecting the illumination from the lamps.

The foregoing description of the composite system has dealt exclusively with the superposition of direct and alternating currents. An equally interesting and profitable application of joint transmission is rendered possible by the non-interference of asynchronous alternating currents.

It is a fact well appreciated by all engineers that for polyphase motor service a low frequency is desirable, inasmuch as the lagging current demanded by motors can most satisfactorily be

transmitted when the line inductance is small. This fact, therefore, dictates the adoption of a low-circuit frequency. A low frequency, however, is not adapted to lighting. A system ideal in its simplicity is found in the joint transmission of low-frequency polyphase currents for motor service and high-frequency single-phase currents for lights. For this purpose the four wires of the separate phases of the two-phase system are admirably adapted. The two wires of one phase are used conjointly as the one conductor of the interposed single-phase system, the return path being by way of the two wires of the other phase. In the generating station the two terminals of the single-phase generator are connected to the separate neutral points of the two-phase circuits, and in the distributing transformer station the single-phase receivers have their leads tapped at the corresponding two neutral points of the primary coils of the lowering transformers of the two-phase system. Each circuit of the two-phase system operates independently of the other, and neither has any effect whatever upon the single-phase system. Thus, synchronous and asynchronous motors may be thrown into service and overloaded to any degree without producing a fluctuation in the brilliancy of the lamps, a condition hitherto impossible of realization by former methods of operation.

It is a fact that the three-phase system of transmission is so much more efficient than the two-phase that, in changing from the latter to the former, one of the four wires may be removed without altering the line loss. The composite system is, however, sufficiently superior to the two-phase system alone in point of economy of conducting material as to more than compensate for the decrease in circuit economy due to the change from the three-phase to the two-

phase system on account of the additional single-phase load which may be carried. Thus, the two-phase single-phase interconnected circuits will allow of the transmission of 150 per cent. as much power at the same percentage of line loss as either the single-phase or the two-phase system alone, all other conditions remaining the same.

The copper economy incident to the method of joint transmission of asyn-

chronous currents would alone, perhaps, not offer sufficient inducements to assure its adoption in preference to the popular three-phase system. The most prominent characteristic of the composite transmission, and that which will appeal to the engineers of our long-distance transmission equipments, is the independence of the regulation of the electro-motive forces of the component systems.

Automobile Wireless Telegraph Stations

SOME weeks ago there appeared on Broad street, New York City, on the site selected by the curb brokers as their field of operations, an automobile, which excited much comment and speculation from interested spectators; and since its purpose has become known it has become the cynosure of all eyes in that neighborhood.

This vehicle is known as Wireless Automobile Station No. 1 of the American De Forest Wireless Telegraph Company. It consists of the body of an automobile, on which is mounted a large glass case containing the wireless telegraph outfit and the operator. Reaching into the air a distance of 12 or 15 feet is a brass rod about one inch in diameter. This rod takes the place of the usual mast or tower on top of which is fastened the antennae or collector usually made use of in wireless telegraph operations, and from the collector which surmounts its top the vibrations are sent out, reaching

a number of brokerage houses in the vicinity in the form of quotations of the curb market.

The automobile derives its current from a set of 48 cells of storage battery, six cells of which supply the current necessary to operate the wireless instruments. Although in this system the induction coil is dispensed with, one is used in this instance temporarily in conjunction with a two-inch spark coil, giving a spark two inches in length. A later type of automobile station which is now being constructed by the company will be equipped with a motor generator set operated by storage batteries, the pressure of which will be raised to 20,000 volts by means of a step-up transformer.

It is stated that five brokerage houses are now equipped with receiving instruments of this type, and it is claimed that the installation of the wireless service for the transmission of curb quotations

means a saving of 15 minutes over the old messenger system. When the lightning-like fluctuations of the stock market are taken into consideration, it will readily be seen that this saving in time is of considerable importance to brokers and their customers. According to the method now in vogue the messengers of the different brokerage houses are posted among the curb brokers, and either deliver the quotations in writing to their concerns or telephone them, but now, with the wireless automobile station, a reporter gives them to the operator in the automobile, who in turn transmits them to the different receiving stations. Among the stations is one in the office of the "Wall Street Journal," which on February 7th published the first wireless curb quotations.

Wireless telegraphy is put to a very severe test in these operations on account of the large amount of steel used in the buildings, the steel acting like so many antennae or receiving wires. The company states that 90 per cent. of the current is absorbed by these obstructions, and that 100 feet in the downtown district is equal to one or two miles out in the open country, where

interfering objects are very few and far between. At present, on account of the small number of stations, it has been found unnecessary to equip them with masts or poles, but as the service is extended it will probably be found advisable to make use of a short pole, which can be put up outside of the window of each receiving station in the manner of a flagstaff.

The company is now equipping three additional automobile wireless stations, one of which will be used in Chicago for transmitting curb quotations, and another to be used in Providence for demonstration purposes.

Although the demonstrations so far have been rather of an experimental nature, the future bodes well for this method of transmitting intelligence, and ere long we may hear of our principal railway trains being equipped with wireless instruments, so that the train despatcher can keep in constant communication with all the trains moving on his division. In view of the many railway accidents of late, it would seem that this problem should forthwith attract the attention of the wireless telegraph engineer.



The United States Government Rule for the Safe Working Pressure of Steam Boilers

By W. H. WAKEMAN

WHEN I first heard or read a criticism of the rule adopted by the Board of Supervising Inspectors of the United States Government for this purpose, it seemed very improper for any less authority to venture a criticism of their laws, and as there appeared to be no greater authority, the natural conclusion was that no criticism should be offered at all. Further consideration of the subject, however, brought out the idea that if they were wrong in the matter, there is no good reason why they should not be criticized the same as any one else, therefore the factor of superior prestige is taken out of the case altogether, and their work must stand on its merits. Since then the whole matter has been very carefully reviewed, and the conclusions reached are found in this article.

It will not take long for any engineer who is interested, to apply the rule, as it is frequently stated in print, and thereby discover that the pressure allowed on boilers to which it is applied is much greater than some other rules allow; also, that in many instances boilers would not and are not considered safe when carrying such high pressures. A rule which gives satisfactory results may be stated as follows:

Multiply one-fifth of the tensile

strength of boiler plate by its thickness and by the strength of joint. Divide by one-half the diameter, and the quotient is the safe working pressure.

The United States Government rule is usually quoted as follows: multiply one-sixth of the tensile strength of boiler plate by its thickness in inches and divide by one-half the diameter. Quotient is the safe working pressure.

One class of superficial students of the latter rule claims that the factor of safety is greater than in the former, and strongly condemns those who favor it because it takes one-fifth of the tensile strength as a basis for the calculation.

The United States Government rule does not use 6 as a factor of safety, but usually uses less than 4; therefore the former rule quoted is more conservative than it is given credit for.

The principal stumbling block in the path of those who condemn the United States rule seems to be the omission of any reference to the strength of joint in the boiler plate, according to their version of it, which I have already quoted; but the plain facts in the case are that this rule is sadly misrepresented and misapplied, therefore the fault lies with those who criticize it without full investigation, more than in the rule itself.

This rule is misrepresented because it

is only partially quoted, one of the most effectual ways of making any rule appear different from what it really is which has come to my knowledge.

It is an undisputed fact that the strength of a steam boiler depends on the efficiency of the joints; therefore this point should be fully investigated. The strength of a riveted joint depends on the distance from rivet hole to edge of plate, the pitch of rows of rivets, the diameter of rivet holes—assuming that when the rivet is driven it fills the hole—and the pitch of rivets. The United States Government rule, when wholly and correctly quoted, includes all of these points. A rule is given for each item, the same as if it stood alone, and after they are all given—thus determining the exact condition of the joint—it is not necessary to repeat the matter in detail, or even refer to it, when quoting that part of the completed rule which refers to the tensile strength, thickness of plate and diameter of shell.

I shall mention these as separate rules, for they are given as such; but all must be included in one to make it complete. Briefly mentioned, these rules cover the following points:

1. Distance from rivet holes to edge of plate in any joint.
2. Distance between rows, or the pitch of rows of rivets.
3. Diameter of rivet holes for single riveted joints, iron plates and iron rivets.
4. Diameter of rivet holes for double riveted joints, iron plates and iron rivets.
5. Diameter of rivet holes for single riveted joints, steel plates and steel rivets.
6. Diameter of rivet holes for double riveted joints, steel plates and steel rivets.
7. Pitch of rivets for single riveted joints, iron plates and iron rivets.
8. Pitch of rivets for double riveted joints, iron plates and iron rivets.

9. Pitch of rivets for triple riveted joints, iron plates and iron rivets.

10. Pitch of rivets for single riveted joints, steel plates and steel rivets.

11. Pitch of rivets for double riveted joints, steel plates and steel rivets.

12. Pitch of rivets for triple riveted joints, steel plates and steel rivets.

In addition to these specifications it gives directions for pitch of rivets for single, double and triple riveted double butt strap joints, where all the material is steel. (See "A Library of Steam Engineering," by John Fehrenbatch, M.E., formerly supervising inspector).

The result of an application of this complete rule to the design of a boiler is the determination of the condition, hence the strength, so far as a theoretical calculation can determine it, of every part of the joint and plate.

Of course if that part of it which takes into account only the plate and the diameter of boiler, is applied in a careless manner to any boiler which happens to be found in use, designed by some boiler maker who thought more about adopting a plan that would save him work, hence expense, than he did about securing the greatest possible efficiency, it will not give satisfaction, because it was never intended for such haphazard use.

When this rule is carefully followed, some of the single riveted joints possess over 60 per cent. of the strength of solid plate, while some of the double riveted type show about 75 per cent. of it, which certainly is a very good showing.

Having demonstrated that the portion of rule usually quoted really does take into account the efficiency of joint, although it apparently does not—and I well remember the time when I thought it defective in this respect, because I had not given the matter sufficient study—let us see what the real difference between the two rules under discussion is.

For this purpose take a boiler built according to the following specifications:

Tensile strength of plate, 60,000 pounds.

Thickness of plate, .5 inch.

Comparative strength of joint, .60.

Diameter of boiler, 66 inches.

Applying the first rule quoted the following result is obtained: $60,000 \div 5 \times 5 \times .60 \div 33 = 109$ pounds.

Applying the United States Government rule as usually quoted, the following would be the result: $60,000 \div 6 \times .5 \div 33 = 151.5$ pounds.

There is a vast difference between these results, but there seems to be some confusion concerning its real cause. In order to illustrate this, it will be necessary to determine the bursting pressure in both cases, by using the tensile strength without division.

In the first case it is

$$60,000 \times .5 \times .60 \div 33 = 545 \text{ pounds.}$$

In the second case it is $60,000 \times .5 \div 33 = 909$ pounds, provided we do not take the strength of joint into consideration; but this cannot be left out in an example like this, where the bursting pressure is wanted; therefore the calculation becomes $60,000 \times .5 \times .60 \div 33 = 545$ pounds. This shows that the two calculations agree, when the whole is considered, but does not show the true factor of safety. This is found by dividing the bursting by the safe working pressure.

In the first case it is $545 \div 109 = 5$. In the second it is $545 \div 151.5 = 3.6$.

There is a clause in the United States rule, following the part already quoted, as follows: "For double riveted seams add 20 per cent."

This makes some difference in the application of both rules, as it raises the comparative strength of seams to .75, if we take the highest available.

Applying the first rule, assuming the increased strength of joint, the following results: $60,000 \div 5 \times .5 \times 75 \div 33 = 136.4$ pounds. The bursting pressure by the same rule is $60,000 \times .5 \times .75 \div 33 = 682$ pounds. The factor of safety is $682 \div 136.4 = 5$.

Applying the second portion of a rule quoted, this result is obtained: $60,000 \div 6 \times .5 = 151.5$, to which must be added 20 per cent. for double riveting, making it 181 pounds. The bursting pressure by this rule is $60,000 \times .5 \times .75 \div 33 = 682$ pounds. The factor of safety is $682 \div 181 = 3.7$.

This demonstrates very plainly that the only substantial difference between these two rules is in the real factor of safety employed, provided it is applied under proper conditions; therefore the matter resolves itself into the following question:

Shall we adopt a factor of safety of 5 or of 3.6?

I wish to suggest the following answer to this question: For boilers that are built under miscellaneous conditions, and operated where the care bestowed upon them is good, bad, or indifferent, as the case may be, a factor of 5 is none too large, and perhaps not large enough.

On the other hand, where they are designed and built according to United States Government specifications, inspected in accordance with the thorough methods required, and operated by men licensed by the government after a strict examination into their qualifications, a factor of 3.6 is high enough.

I wish to mention one more point in closing. It is perfectly useless to argue against success, and when used according to directions, the United States Government rule for the safe working pressure of steam boilers is a success.

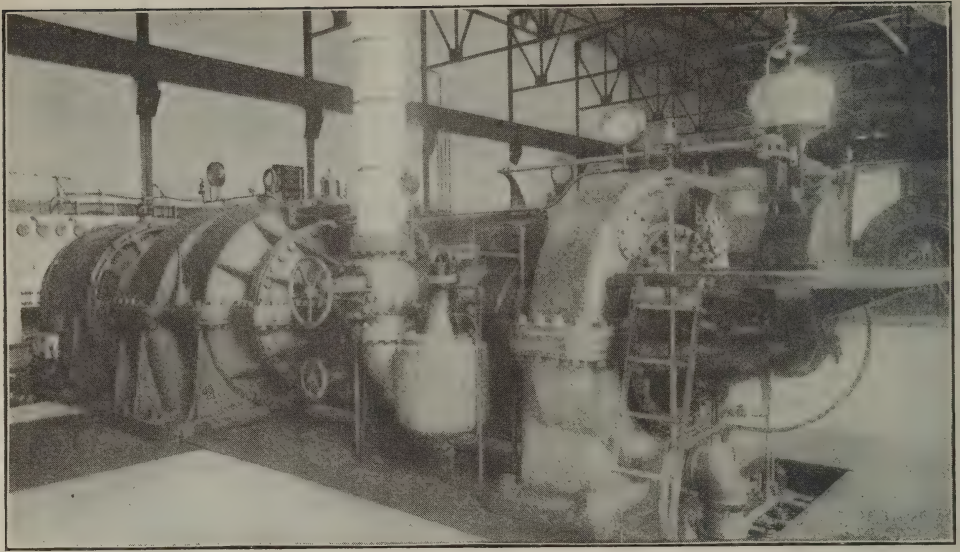

1500 K. W. Turbo-Generator Unit in the Plant of the Hartford Electric Light Company, Hartford, Conn.

The Steam Turbine as a Reserve Power in Mill Service

IT is a significant fact that, in the face of recent criticism of the steam turbine as an uncertain source of power, the turbine is nevertheless receiving recognition as a dependable prime mover, and is being rapidly introduced in power and manufacturing plants for the very purpose of relaying other forms of prime movers which are more susceptible to stoppage by reason of their comparative complication of construction and resultant vulnerability. The severe requirements of relay power necessitate the employment of apparatus capable of sustaining sudden and protracted loads, and of such construction as to be available at all times for immediate duty when some part of the main power system

fails. Such apparatus must in addition be compact, economical of steam and, above all, reliable in its operation. These requirements are briefly discussed below in the order of their importance. Barring the gas engine, which, however, possesses many features quite applicable to this class of service, the field is open to two types of steam driven apparatus, the reciprocating steam engine and the steam turbine.

The steam engine to-day demonstrates to what extent a complicated mechanism may be perfected, standardized and rendered efficient and reliable by years of slow development. It of course furnishes a basis of comparison for other types of prime movers, the turbine not

excepted. A practical demonstration of the operation of a turbine plant is furnished at the works of the Westinghouse Air Brake Company, at Wilmerding, Pa. The plant has been in operation for over three years, with a regular daily run of eleven hours, furnishing current for the entire works, in which an alternating current power system has been installed to replace the original steam power system. At frequent intervals part of the plant is operated for twenty-two and twenty-three hours per day, and the entire installation has given a degree of satisfaction and economy quite comparable with that of the best steam plants. It is of much significance that a manufacturing concern of such magnitude should deliberately discard their steam power system and install a system absolutely dependent upon steam turbines for motive power. Such action is a sure indication of the reliability of the turbine. Many European plants and those in America, such as the Hartford Electric Light Company and the Yale & Towne Manufacturing Company, Stamford, Conn., give further evidence of the most satisfactory operation.

The construction of the steam turbine, referring particularly to the parallel flow type, obviously favors quick starting. The distribution of steam throughout the working parts is symmetrical, and the danger of rupture from excessive initial condensation is remote. In this turbine a small by-pass is provided for "warming up," which is accomplished in much less time than with a reciprocating engine, suitable drains being provided to keep the interior entirely free from water. Should steam be introduced too soon, no harm would ordinarily ensue save initial loss of economy due to fluid friction.

In this feature the steam turbine leads; it is the least vulnerable part of the

power system. Its operative factor of safety is invariably greatly in excess of that for which the standard generator which it drives is designed. Relay power apparatus is liable to be called upon to sustain heavy overloads for long periods. In order to provide for such emergencies the reciprocating engine must be liberally designed in all of its parts, considerable margin of mechanical strength being reserved for instantaneous overloads, such as short circuits upon the power system, the destructive reactions of which act far more quickly than the most sensitive current interrupting device. This results in an engine of much heavier construction, consequent increased cost, and of lower average economy than would otherwise be required for normal loading.

The steam turbine is not specially designed for reasonable overload conditions, but is nevertheless entirely capable of sustaining heavy overloads by reason of its inherent strength of construction and ideal symmetry of proportion and working parts, thus avoiding the necessity of special designs. Its overload capacity depends in a large measure upon the character of the steam supply and the condensing system as well as upon the capacity of the generator to which it is connected. A feature of the parallel flow type of turbine is the means provided for increasing the capacity to approximately 150 per cent. of normal rating in case of necessity. This is accomplished by a steam by-pass shunting the high pressure cylinder and allowing steam at boiler pressure to enter the low pressure cylinder and impinge directly upon the low pressure blades. The steam economy is somewhat reduced, but the loss in this instance is quite insignificant when compared with the advantages to be derived from the arrangement which enables maximum economy

to be obtained under normal loading, together with large overload capacity, which would, in the steam engine, be necessarily accompanied by heavier construction and lower economy at normal loading.

From a structural standpoint the steam turbine is perhaps the most uncomplicated of mechanism, consisting as it does of but two parts, resembling in their relations the stator and rotor of an induction motor. The replacement of pistons, cranks, valves and other reciprocating mechanism by simple rotative mechanism not only contributes to its efficiency and inherent strength of construction as a prime mover, but also accomplishes the solution of the problem of parallel operation of alternating current generators, a problem heretofore solved only by the aid of heavy flywheels and expensive valve mechanism. Mechanically the most vulnerable parts of the steam turbine are the rows of blades mounted upon the periphery of the rotor. In the parallel flow type turbine these blades have a minimum factor of safety of forty, or in other words operate at but 40 per cent. of their ultimate tensile strength. The turbine casing is invariably designed for full boiler pressure with the usual factor of safety. The bearings are constructed of concentric gun metal tubes, each fitting loosely into the adjacent ones. They are continuously flushed with oil, so that the rotating member is virtually supported upon a series of oil films which provide sufficient flexibility to absorb an eccentric motion at starting and prevent practically all wear of metal parts. The inlet valve and governing mechanism are of simple and accessible construction and rapid and positive in their operation, thus enabling severe load fluctuations to be easily taken care of, and an excellence of speed regulation to be secured that is

unobtainable in other forms of prime movers without the assistance of expensive valve mechanism and heavy fly wheels.

Perhaps the most valuable feature of the turbine as a reserve power is its economy of floor space. This point in many instances is of the most vital importance, and it is often the case that a complete turbine unit may be installed in an available corner of an engine room or factory when it would be entirely out of the question to install a suitable reciprocating engine even of the most compact type. The turbine unit roughly occupies two-thirds of the floor space necessary for the vertical and two-fifths of that for the horizontal compound engine of the same power. This comparison, although more applicable to larger units, is even more favorable to the turbine units of small power such as that subsequently described.

Of the many forms of steam engines now in use, none save the most complicated type of multiple stage engine can approach the turbine in steam economy. A 400 kilowatt unit, similar to those in operation at Wilmerding, gives a consumption, upon full load, of 14.47 per E. H. P. hour, which, in comparison with an engine driven unit of 85 per cent. combined mechanical efficiency, is equivalent to 12.4 pounds per I. H. P. It is doubtful if the ordinary compound reciprocating engine will ever reach a state of perfection represented by these figures of steam consumption which are so easily obtainable in the case of turbines, without complication or unduly expensive construction.

The preceding discussion of the particular merits of the steam turbine as a reserve power may be appropriately supplemented by a brief account of a new turbine equipment in process of installation at Portland, Me., in the Cumberland

Mills, operated by S. D. Warren & Co. The mills are at present supplied with power from several sources, viz. : nearby water powers transmitting current at high potential to the mills, and an auxiliary steam plant. The electrical equipment furnishes current for lighting, power and electrolytic work, and the water powers are mainly depended upon to supply the mills with electric power, special loads and processes being taken care of by the steam plant.

In anticipation of deficiencies in water supply and trouble from anchoring or floods, a steam turbine generating unit will be installed in the mills for the purpose of a relay or reserve power.

The turbine is of the parallel flow type, of 400 kilowatt capacity, and will operate under a steam pressure of 165 pounds, receiving its supply from a boiler plant located some distance (350 feet) from the unit. The steam before entering the turbine will be super-heated approximately 100 degrees Fahrenheit by means of an independent superheater located just outside of the building and fired by waste hydrogen gas rising from the electrolytic baths. This gas has heretofore been a waste by-product, and is here utilized for the purpose of re-evaporating condensation in the long steam line and superheating the steam to a point where the increased economy of the turbine at superheat temperature is available. The turbine will operate at a high vacuum, 28", which is supplied by a condensing system employing a surface condenser with gravity circulation.

The generator is of 400 kilowatt capacity and supplies two-phase current at 2200 volts, and a frequency of 60 cycles per second. The generator is mounted upon the same bed-plate as the turbine and is direct driven from the turbine shaft through a flexible mechanical coupling. The steam supply is passed up-

ward through a steam strainer for the removal of accidental foreign matter, thence into the steam chest and through the governor valve into the turbine proper, emerging after expansion through the successive stages into the exhaust chamber, which is integral with the frame and entire bearing of the turbine. The space occupied by the unit is 70 square feet, or 0.13 square feet per horse power. The steam economy will approximate 13.5 pounds per E. H. P. at 100 degrees superheat, which is equivalent to less than 11.0 pounds per I. H. P. as rated in reciprocating engine practice.

A closing reference may be made to the turbine installation at the Hartford Electric Light Co. The turbo-generating units in this plant are of 2,000 horse power capacity, generating 2,400 volt alternating current, and were installed as a reserve to the main plant which runs by water power. The turbine was started in April, 1901, and is put in service one or two days of each week, when it carries the entire station load averaging 1,800 kilowatts. The steam consumption at this load with 25 degrees superheat was 19.1 pounds per kilowatt hour, equivalent to 11.46 pounds per I. H. P. hour at engine rating, and the results of approximate test indicate an operating cost referred to the coal pile of but 47.5 per cent. of the cost of power generation by Corliss engines of corresponding capacity, forming part of the steam reserve equipment. The steam turbine at Hartford is at the present time the largest turbine in operation, but much larger machines, of 5,000 horse power capacity, are in the course of construction, which will in a measure seem to inaugurate the employment of this form of prime mover in extensive power service of continuous as well as intermittent character.

The Electrical Phenomena of the Animal Body

By PERCY G. STILES, Ph. D.

PART II.

IN the first part of this article it was pointed out that the electric currents developed in the tissues of living animals are not to be regarded in any different light from that in which we view the familiar facts of movement and heat production. The three forms of energy—electrical, mechanical and thermal—all arise from the chemical processes in the cells, and no one of them should be regarded as more mysterious than the others, or less rigidly subject to the laws of the material world. It was further shown that the electric currents generated by most animals are quite insignificant in quantity and intensity.

The striking exception apparent in the case of the electric fishes deserves to be discussed more fully than was possible before. An English physiologist, Gotch, has given the best account which we have of these singularly armed animals. Several species are known, and there is no external feature to lead one to suspect that they have a remarkable endowment in common. Their forms vary widely and their habits are no more uniform. At one extreme we have the

exceedingly active electric eel, at the other the flattened torpedo, leading a sluggish life like that of the flounder upon the sea bottom. But each of these fish, if disturbed, can give a shock or a rapid series of shocks, strong enough to constitute a valuable defense against ordinary enemies.

The mode of discharge consists in developing a sudden and very great difference of potential between two regions of the fish's body. The derivative currents arch through the surrounding sea water and traverse the tissues of any other fish near by, particularly if it has actually come into contact with the living battery. The currents are of extremely short duration, but may be repeated many times in a second. In each species the direction of the current is definite and invariable; usually, it is in the long axis of the body, but in the torpedo it is between the upper and under surfaces. Caught between two metal plates, the torpedo may be used as a source of current to produce electrolytic effects or to deflect the galvanometer needle.

When an electric fish is dissected its distinctive property is found to reside in

special organs under nervous control. While these electric organs vary more or less in microscopic detail, their structure presents in each case the same salient features. They can all be divided into minute columns whose direction coincides with that of the current produced, much as a muscle can be resolved into fibres whose axes lie in the direction in which the contraction takes place. These columns in turn are made up of tiny discs piled up as coins may be, and each disc consists of two dissimilar parts. The plan of a single column is highly suggestive of what in fact it is, a veritable voltaic pile. The discs are the units, but are only active momentarily when the impulse reaching each one, through the nerve fibril connected with it, causes some chemical decomposition to occur.

The electric organ may be isolated, like a muscle, and continue for some time to respond to stimuli. It may even be divided into small parts, and these made to yield currents. Experiments with these fragments show that their suggestive structure is not misleading; for if two pieces are measured along the direction of their columns, the electromotive force of each is proportional to its length; that is, to the number of units serially arranged in it. Gotch found that such a fraction of the organ gave a difference of potential between its ends of 26 volts, and since he was dealing with but one-eighth of the total length of column, he inferred that the entire organ might well give a current of 200 volts' intensity. If the voltage depends thus upon the length of the columns that make up the whole organ, the quantity of current must depend on their number. A great part of the current must discharge through the animal's own tissues, which seem strangely indifferent to this violent stimulation.

The specimen which gave 26 volts as

its electromotive force, had a length corresponding to about 600 of the discs stacked in its columns. Gotch therefore estimated the electromotive force of a single disc to be about 0.04 volts. Now this is a value to which the currents produced in the muscles and nerves of frogs approximate. So the difference between the painful discharge of the torpedo and the action currents of ordinary tissues, is probably due less to any profound difference in vital processes than to differences of anatomical structure. What distinguishes the electric fish, is the orderly arrangement in series of units which are individually weak.

It has been repeatedly stated that a lowering of electrical potential seems to be the sign of a breaking down process in the cells, whether it be the normal combustion of fuel substances that accompanies muscular work or the irretrievable dissolution attending local death. Do we ever have a "positive variation," the reverse of this depression? We should expect it if, instead of decomposition processes, we could set up processes of building up (repair, nutrition) in any part of the body. Of course, it is not evident that we can induce such changes at will. Still there is at least one instance that appears to fulfil these conditions.

The heart is a muscular organ which alternately contracts and rests throughout the course of life. At every beat it develops a negative electrical condition, the sign that it is spending itself in the performance of its all-important work. In the intervals of rest between its beats it must make good the loss of substance which it suffers in every contraction. The heart receives a group of nerve fibres whose function is "inhibitory," that is, to check the beating of the organ and to relax it even beyond its usual resting state. Now when the heart of

an animal is "inhibited" by the stimulation of these fibres, it exhibits a positive electrical change. There is room for more than one opinion as to the meaning of this rise of potential, but the following explanation is certainly plausible and tempting. The nerve fibres mentioned are concerned with the nutrition of the heart. When they are stimulated the decomposition processes in the heart muscle are arrested and its motion ceases accordingly. The heart rests and the chemical changes in its cells are all constructive and recuperative. If negativity means decomposition, then the "positive variation" of the inhibited heart

may well indicate synthetical or nutritional processes.

Reference is made to this rather difficult matter in order to lead up to a statement of the beautifully simple principle which seems to underlie all these manifestations of animal electricity. Every cell, so long as it lives, is the seat of opposite chemical changes—it is nourished and it is broken down, it grows and it wastes. If the process of building up is predominant, its electrical potential rises above a certain mean, but when the chief reactions in the cell are cleavages rather than syntheses, the "negative variation" is probably never wanting.



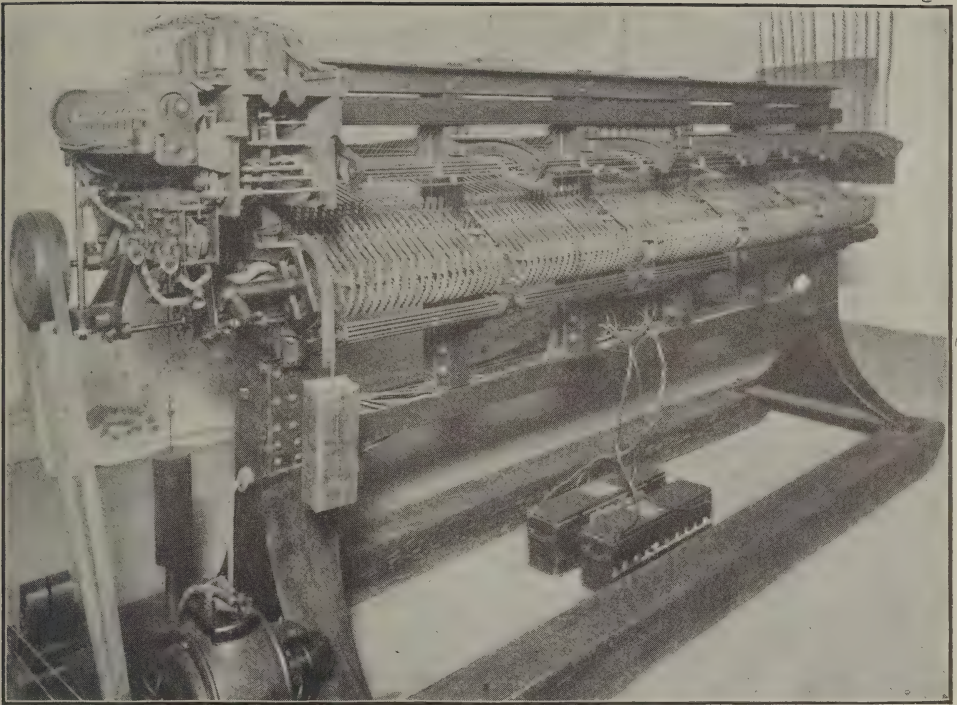

Fig. 1. The Automatic Exchange Operator in its Original Form.

The Faller Automatic Telephone Operator*

By WILLIAM J. HAMMER

FOR a considerable period of time the public mind has been steadily educated up to a high appreciation of, and great confidence in automatic time, energy, and money saving appliances. In the telephone field the subject of automatic telephone exchanges has been one which has at-

tracted a great deal of attention ever since the original work in this direction of Messrs. M. D. and F. A. Connolly and F. J. McTighe, whose system the writer had the pleasure of examining as long ago as 1881, at the first electrical exhibition held in Paris.

The above system has been the basis of very many of the patents which have since been taken out on automatic tele-

* A paper read at a recent meeting of the American Institute of Electrical Engineers.

phone exchanges; and it is my privilege to-night to present for your consideration a radical departure in automatic exchanges which embodies a new principle of which it is the pioneer exponent. It is the invention of Mr. Ernest A. Fallor and is a most meritorious and ingenious piece of apparatus, and is termed the "mechanical operator," in contra-distinction to all other types of automatic exchanges, as it is the only invention which does the work of switching in a telephone exchange in exactly the same manner as is done by the human operator, and by exactly similar means. It is a light machine, and occupies comparatively little space. It is driven by power, and moves mechanically the equivalents of the ordinary plugs and cords in the usual switchboard, connecting the subscribers' terminals together when desired, signalling both parties, and disconnecting the same automatically when parties have finished speaking; and accomplishing this without necessitating any departures from the general arrangement of circuits met with in standard practice; and doing

away with all but a fraction of the relays, magnets, electrical contacts and connections essential in all other systems, both manual and automatic.

The multiple system of telephone exchanges has now reached a very high degree of perfection; and it has become more and more costly; and it is well understood that as the number of subscribers connected to any manual or automatic exchange increases the operating and maintenance expenses increase in far greater proportion than the number of subscribers, because of the increase in the number of multiples.

There is an urgent demand to-day for a system which will very materially cut down these very heavy expenses, and cut off the very heavy outlay now necessary for operators' salaries.

Before entering into a description of the apparatus itself, it will perhaps be as well to consider just what the functions are which the human operator fulfils in connecting and disconnecting subscribers, and in what way the mechanical operator duplicates these functions; and I will, therefore, place them side by side:

Cycle of Operations.

The Automatic System.

1. The subscriber sets his sender to the number wanted and winds it, his responsibility ending there.
2. The exchange drops his (the subscriber's) terminal shuttle, which starts his sender going.
3. The sender sends a signal into the exchange selector, thereby establishing one of a hundred local circuits.
4. The exchange drops shuttle of subscriber wanted.
5. The motive power at exchange lifts both shuttles into an idle bus bar. (This operation has no parallel in manual working.)
6. The ringing device rings bells of both subscribers.

Manual System.

1. The subscriber takes the receiver off its hook.
 - 1a. Operator notes "pilot" light signal and individual signal light.
2. The operator places an answering plug in his jack upon seeing his signal displayed.
3. Operator raises the listening key cam, which depresses the key, thus enabling her to communicate with the subscriber.
4. She asks "number" (this operation has no parallel in the automatic exchange, as the starting of sender is a natural consequence of the dropping of shuttle).
5. The subscriber gives the number wanted.
6. The operator repeats the number to prevent error.

The Automatic System.—Continued.

7. The subscriber, on hearing signal, takes off his receiver. (This operation not in manual practice, as receiver there is off already.)

Manual System.—Continued.

7. Operator must select "jack" wanted.

8. Operator makes a busy test by tapping with tip of her plug the collar of the multiple jack of the line wanted.

9. The operator plugs the multiple jack of subscriber wanted.

10. Operator presses ringing key, thereby ringing up subscriber wanted.

11. Operator restores the listening key, cutting herself out.

12. Operator notes that subscriber's signal lamp goes out.

Next, conversation begins.

Upon its Termination,

8. Subscriber hangs up receiver.

9. Clearing-out magnets drop both shuttles back to rest.

This is the entire series of operations gone through in a "successful switch."

13. Subscriber hangs up receiver.

14. Two (2) keyboard signals light.

15. Operator removes both plugs of the pair from jacks.

Should, however, a busy line be called, then the following happens:

Busy Test.

The Automatic System.

1, 2, 3 same as above.

4. Operator attempts to drop called shuttle, but it is out of the way, and a special circuit is opened.

4a. Shuttle is for a moment hung up, but then clears out again.

(No further operations follow, as subscriber waits for bell before taking down receiver.)

It will be noted from above that the number of operations necessary varies, and favors considerably the mechanical operating system, those requiring the subscriber's attention are less in the automatic, and he need not wait for the

Manual System.

1, 2, 3 same as above.

4. Operator in multiple board taps the collar of the multiple jack of the line wanted, and she receives a series of "clicks" known as the busy test.

5. Operator tells calling party line is busy.

6. Subscriber hangs up receiver.

7. Operator removes answering plug from calling subscriber's jack.

operator to question "number," and after receiving the same repeating to prevent error and save that time, as well as the time often lost in getting the operator to understand the correct number, etc.

Comparison of Apparatus Forming Salient Features of Both Systems.

The Automatic System.

1. Subscriber's instrument.
2. Sender.
3. Subscriber's line.
4. Protective devices, lightning arrestors, heat coils, etc.
5. Subscriber's terminal carriage with contact springs and connecting rod.

Manual System.

Same.

Not in Manual.

Same.

Same.

This is represented in a manual exchange by subscriber's line jack.

This is equivalent in office to subscriber's drop or lamp signal and its operating relay, cut-off relay, also puts line lamp out by cutting out line relay.

Same.

The Automatic System.—Continued.

6. Individual magnet.

Above comprises the first group of exchange apparatus, and there are as many above items as there are subscribers.

Automatic.

Manual.

Group 2—

1. Bus bars.
2. Shuttle locks.
3. Clearing-out magnets.

The apparatus in this group is present in a number equal to one-tenth of the number of subscribers.

Cords and plugs.

Clearing-out drops or supervision signals.
Same.

Automatic.

Manual.

Group 3—

1. Battery and leads therefrom, or dynamo.
2. Operating power.
3. Operating mechanism proper.

The apparatus in this group is provided once only per section of 100 lines.

Same.

These two items are represented by the operator in a manual exchange.

Same.

Description of the Automatic System and its Operation.

It is difficult to give a complete technical description of this system without recourse to many numbered drawings, diagrams, photographs, etc.; and those who are specially interested in this subject will find it of great service to witness the actual operation of the system itself, which may be seen at the present time

in New York City.

This system comprises two separate devices: 1st. A "mechanical telephone operator," situated at the telephone exchange, the original form of this being shown in Figure 1; 2d. A "sender," or signalling apparatus, as shown in Figure 2.

The Sender.

Let us first consider the "sender" and its functions. It is preferably placed near each subscriber's telephone, and by its means each and every subscriber is enabled independently to control the mechanical operator at the central exchange. There is no mechanical connection of any kind between the subscriber's instruments and the "sender"; and it can be attached without cutting the circuit; it being only necessary to connect it in parallel across the existing line and to ground. The ground connection is one made for the switching act; when the instruments are idle and during conversation they are free from ground.

The subscriber's "sender" or calling apparatus consists of a small metal box containing a set of disks, numbered on the periphery from 0 to 9—one comprising the units and the other the tens; and in the case of higher numbers being employed, additional disks are attached—three disks would give numbers up to 1,000; four disks would give numbers up to 10,000, and five disks up to 250,000. The number of the subscriber to be called is displayed in a line across the "sender" face, and a series of impulses corresponding to this number are sent over the line to the exchange by means of a clock work started by turning the calling lever projecting from the front

of the "sender." This lever upon being turned upwards winds the spring of the clock work; it then returns to its first position, where it is locked, thus preventing further interference until the call has been sent and properly received at the central exchange. When the "sender" starts the varying series of impulses which are sent over both legs of the metallic circuit simultaneously, the ground—which has been automatically thrown on—is used for a return circuit. The "sender" also contains a magnet whose armature normally retains the clock work until the magnet is energized by current from the exchange. As in the case of a messenger call or fire alarm box, the calling lever must be turned to its full extent to send a signal, and after this has been done, the protective devices in the "sender," as already stated, keep all the essential parts of the "sender" locked during the dispatch of the signal. When the switch is completed at the exchange, the subscriber, as well as the party whom he has called, receives a bell signal. There are four of these signals given to call subscribers, covering a period of 30 seconds' time,

this period giving the called subscriber time to reach his telephone. As soon as he has taken off the receiver the signals cease and conversation begins.

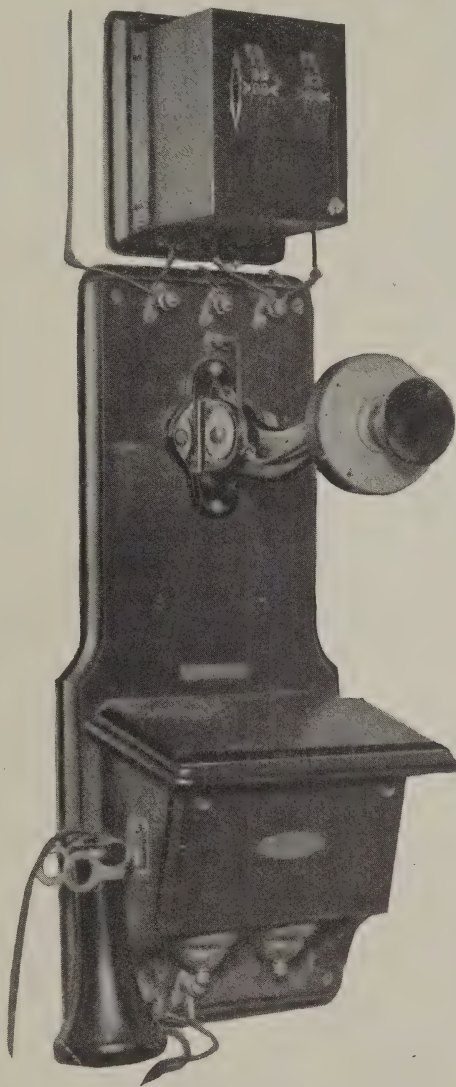

Fig. 2. Subscriber's Instrument and Sender.

The Mechanical Telephone Operator.

We will now consider the operator (shown in Figure 1) and its functions:

All subscribers' circuits are normally free from ground, and as already stated, the subscriber's calling device or "sender" is normally open, both as to ground and metallic circuit. In Figure 3 is shown a diagram of the circuits.

Each subscriber's line terminates in one place only at the exchange—this being a feature not possessed by other automatic systems—each subscriber's line, consisting of two wires, is connected at the exchange to two parallel rods on the mechanical operator.

These rods are insulated from the rest

of the machine, each pair supporting a carriage, mounted so as to slide on these rods.

This carriage holds the subscriber's terminal springs, which are insulated from each other, but each spring makes an electrical contact with one of the two rods.

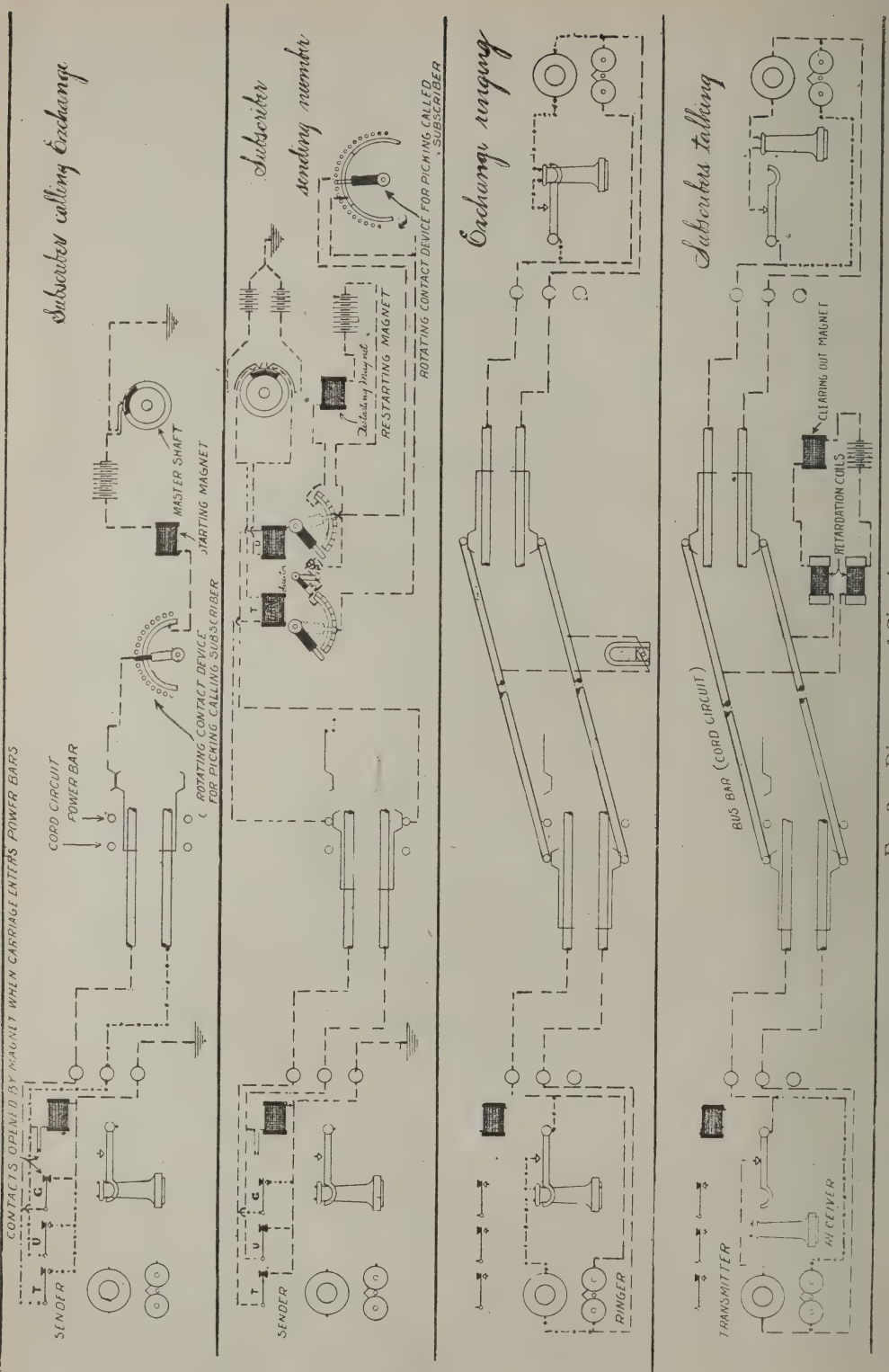

FIG 3.—Diagrams of Circuits.

The springs on the carriage are adapted to slide by, or at some particular point to make contact with one of a series of bars laid in a grill at right angles to and above the carriage rods.

All of the rods or bars employed in the machine are of such dimensions as to have practically no resistance, and the conducting bars and loop circuits connected with them containing impedance coils, and a source of electrical energy, such as a storage battery, and constitute the equivalent of the cord circuits of the manual exchange, and in their functions correspond identically therewith.

While the number of subscribers' terminal carriages is equal to the number of subscribers' lines, the number of cord circuits, or pairs of parallel bars necessary, need not be more than 10 per cent. of this number, this figure having been found safe in manual exchange practice. There are instances in which boards have had to be equipped with twelve and even sixteen cord circuits per 100 lines, but the average present multiple practice is from seven to ten.

It is never found that all subscribers wish to talk at one and the same time.

When the subscriber's line terminal switch or carriage at the exchange is at a position of rest, one of the subscriber's line terminal springs makes a contact with the ground spring, which is connected to one of a circle of commutator pins. These pins are swept over by a revolving brush attached to the shaft of what is termed the "busy wheel," which is normally in rotation. There are as many pins on the commutator as there are subscribers, and the revolving brush establishes a connection between

a ground spring (subscriber's line) and a battery, operating magnet and ground.

The "busy wheel," to which the commutator brush is attached, is driven by a friction clutch from a power device operated preferably by an electric motor, and is arranged to be stopped by a "pawl" and "ratchet" controlled by the operating magnet, termed the "starting" magnet, which initially controls the entire switching operation of the exchange. The energizing of the "starting" magnet stops the "busy wheel" and starts the operating gear, which passes through its complete cycle, after which the "busy wheel" is again started, continuing to revolve until the "starting" magnet is again energized.

A second magnet, termed the "restarting" magnet, is employed to start the "master shaft" going again; in order that the carriage-moving or cord-circuit operating device of the called subscriber may be thrown into gear.

These two "starting" and "restarting" magnets operate in conjunction with the subscriber's "sender" through the medium of a controlling contact apparatus and selector.

The commutator above referred to consists of two sets of circularly disposed contact pins, the number of the pins in each circle representing the number of subscribers.

There are also two metal contact rings, one of which is solid and the other divided into ten equal segments.

The rotating trailer arm attached to the "busy wheel" shaft sweeps over these contacts. The contact pins of one circle are each connected to a separate ground terminal spring; and one of the contact

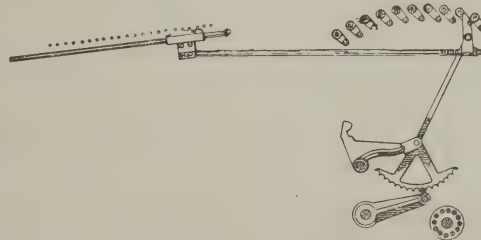

Fig. 4. Subscriber's Unit, Original Form of Operator.

rings is connected in circuit with the "starting" magnet, a battery and ground connection. The purpose of the contact device is to prevent any other subscriber from throwing the "starting" magnet into operation while switching is going on; the circuit in this "starting" magnet being always opened, save when the "master shaft" is at its point of rest. Each subscriber's line is brought into connection with the ground—once in each revolution, by the revolving contact arm.

The "busy wheel" which has been referred to, consists of a shaft extending through the entire length of the "mechanical operator," which carries mounted upon it and disposed around it in the form of a helix of a single turn, a series of resilient fingers of thin sheet steel, their number corresponding to the number of subscribers.

When the "busy wheel," which is normally running, has been stopped by an impulse sent through the "starting magnet," one of the steel fingers, which is always the one in a perpendicular position, remains resting against the latch holding that particular subscriber's terminal carriage. Next the power mechanism acting through a clutch and cam shoves forward a light shaft termed a "rack," which is studded with pins corresponding to the number of steel fingers and latches, and which runs parallel with the axle of the "busy wheel." As this "rack" moves longitudinally, the up-

right steel finger is bent over by a rack pin tripping the latch and thus releasing that subscriber's rod and shuttle, which drop into contact with a long lantern pinion; this pinion then rotates through an arc dependent upon the number of subscriber's lines busy at that time. Instantly a level engages the two subscriber's shuttles, lifting them up so that their hook heads engage a shuttle detent. There are as many of these detents as there are talking circuits, i. e., one-tenth the number of subscribers (in this machine the number being ten).

A circuit is now established between the springs of the subscriber's carriage and the grid bars representing the cord circuit terminals.

The magneto generator is now thrown on the circuit, ringing the bells of both calling and called subscribers. The length of this signal may be varied to suit requirements, and is controlled by a timing device. In the meantime the power mechanism has been automatically thrown out of operation and the "busy wheel" again rotates until another call is sent in.

When the subscriber takes his receiver off the hook a "clearing-out" magnet prevents the switch from clearing out; but when both receivers are hung up, the "clearing-out" magnet becomes de-energized, and its armature causes the shuttles connected to return to their position of rest.

Indirect or Trunking System

Up to the present time we have considered the original type of the operator, as illustrated herein, and applicable to small exchanges up to 100 subscribers and employing the so-called direct connection, requiring a single machine accessible periodically to all subscribers. There have recently been made very important changes in the general design of

the operator and its mechanical details, without altering the general principles under which the system operates. These changes have greatly increased the speed of making connections, cutting the time down to 3 1-2 or 4 seconds for a trunked connection. The new operator is considerably smaller and lighter in weight, more compact, more "get-at-

able," and much cheaper in cost of construction. In this machine also is embodied the indirect or trunking system, applicable to exchanges from 100 up to 250,000 or more subscribers, uniting all, if required, into a single system without sacrificing the plug and cord principle, and without multiplying the subscriber's contacts, as in all other systems, and finally making it entirely practicable to subdivide the lines into groups of 100, thus keeping the dimensions of the connecting machines within moderate limits.

The act of connecting subscribers consists of three functions, each represented by an independent section of the operator. In the order in which these devices are thrown into use, in establishing a connection, they are termed the "originator," the "pilot," and the "terminator."

The "originator" performs the office of establishing a connection of the calling subscriber's line with the "A" trunk. These "A" trunks are conductors connecting the "originator" and "pilot," and their number represents the maximum number of subscribers which would at any time be simultaneously using the section. It is well to note here that these "A" trunks always have their beginning and ending in the "originator" and "pilot" of one and the same unit of 100. In this initial act of the "originator," no selective connection controlled from the subscriber's station takes place; but the "A" trunks which are already in use are made inaccessible to subsequent calls, the "originator" always selecting a free and idle "A" trunk. The end of the first free "A" trunk is connected in the "pilot" with a receiver or selector, which immediately upon the establishing of the connection between the "A" trunk and the subscriber's line, receives a group signal referred to later; and thereupon selects a "B" trunk corresponding to the signal received. Immediately the mechanism of the "pilot"

connects the "A" trunk and the "B" trunk, at the same time breaking the connection between the "A" trunk and the selector, and putting the selector in connection with the next idle "A" trunk—the "B" trunks referred to connecting the "pilot" and the "terminator."

The ends of all of the "B" trunks, coming from one and the same section of 100, are distributed over all the "terminators" of the exchange, rendering it possible by the aid of one of these "B" trunks to establish a connection between the "pilot" and any one of the "terminators." Here, again, as many "B" trunks are provided for each "terminator" as are necessitated by the maximum demand for simultaneous conversations between the two groups.

In the "terminator" the first idle "B" trunk is again connected with a selector which, upon the connection of the "B" trunk with the "A" trunk, receives the number signal. Immediately the connecting machinery establishes a contact between the "B" trunks and the contact element in the "terminator," representing the number of the subscriber wanted, which number has been transmitted to it.

Each subscriber, it will be understood, belongs to a certain group of 100, and in this group he possesses a contact element both in the "originator" and "terminator," these being connected to his line in parallel, protective devices being provided, by means of which, as soon as the subscriber making a call has caused this particular contact element in the "originator" to leave its normal position, his corresponding element in the "terminator" becomes inaccessible to other calls, and should any be made they would result in a "busy" signal.

The ringing up of subscribers, conversation, and the clearing out are done precisely in the same manner as in the direct method of connection previously described.

Certain of the Construction Details.

The "sender" is identical with that already described and employed upon the original type of the operator. The mechanism at the exchange, as I have already stated, embodies the "originator," "pilot," and "terminator."

The "Originator."—This consists of the switchboard, the movement and clearing-out device.

The switchboard consists of 100 perpendicular tracks, upon which 100 shuttles independently ride up and down. The track rails are insulated from one another, and connect in pairs to the subscribers' lines. The shuttles consist of two metallic parts in contact with the rails, but insulated from each other, each carrying a contact spring, by means of which they may be brought into contact with the "A" trunks.

The "A" trunks in the "originator" consist of horizontal metallic rods placed at right angles to the tracks, enabling each one of the shuttles to be brought into metallic contact with any one of the trunk rods. They are arranged in two parallel vertical planes, one in front of and the other behind the shuttle tracks. The ends of these rods are metallically connected to similarly disposed rods in the "pilot." It is self-evident, therefore, that when a subscriber's line is connected to an "A" trunk this is practically an extension of this line into the "pilot."

Each shuttle is provided with an actuating rod, by means of which it may be operated by motive power. In the position of rest, this rod is supported by a trip which, on being actuated by a magnet, allows the shuttle to drop. This magnet receives the current as soon as the subscriber winds his sender—this act resulting in putting the shuttle into its initial working position. The moment

the shuttle reaches this position a projection upon its actuating rod protrudes in the path of a helical projection mounted on a continuously rotating drum, so that the shuttle is carried into its second working position.

The actuating rod cannot be moved further in this direction, owing to a stop in its path; consequently, the drum, which is driven by friction, is brought to a standstill. The moment this happens, the main mechanism is started, actuating the working beam, which extends across the entire switchboard. A projection on this beam seizes the shuttle rod and lifts it into the so-called speaking position, i. e., that in which its springs make contact with the first idle "A" trunk.

On completing its stroke, the working beam returns to rest. This stops the connector movement, and the drum, driven by friction, is again started. The shuttle in the meantime remains in the position in which it was placed. In this position the shuttle actuating rod rests upon a clearing-out bar, which prevents it from dropping back. There are as many of these clearing-out bars as there are "A" trunks. These have a lateral movement, and when moved they release any shuttles which happen to be suspended from them. How this is accomplished will be referred to later.

At the next call the entire operation is repeated, save that the busy "A" trunk is "jumped" and the next one occupied, and so on.

The "Pilot."—In this we find again the switchboard movement, clearing-out apparatus, and in addition a group signal selector.

The construction of the switchboard is identical with that of the "originator," save that the drum is eliminated, and

shuttle actuating rods pass directly from position of rest into second working position.

The "A" trunks from the "originator" again terminate in rods being provided with a branch circuit to the selector. These branch circuits are normally opened, and are opened during conversation over the trunks being closed automatically part of the time during the switching act and during the transmission of the group signal.

The shuttles are here connected to rods in the various "terminators," so that the particular shuttle which is selected decides into which groups the subscriber's line will be extended.

The electrical stop motion in the subscriber's sender permits only partial running down of the "sender," but sufficient to transmit that part of the signal corresponding to the first two figures of the number desired. This is the group signal; and after its transmission the selector in the "pilot" causes the particular shuttle to drop into working position. But immediately the shuttle reaches such a position, the actuating movement is started, and, as already described, establishes connection between the shuttle and that one of the "A" trunks over which the signal came. Thus, the subscriber's line is continued into that one "terminator" in which the subscriber's line which is desired is located; and it now remains to show how the particular line wanted is selected out of the hundred lines in that group. This will be shown in the description of the "terminator."

It is essential to mention here that the circuit, thus far built up, has in it a

clearing-out magnet, and parallel with that a non-inductive resistance, the province of the former being to maintain the established connection until the conversation is finished. A clearing-out in the "pilot" effects a clearing-out in the "originator."

The "Terminator."—Here we find again the switchboard actuating mechanism, clearing-out mechanism, signal selector, and the ringing apparatus.

The construction of the switchboard is identical with the ones already described, the 100 shuttles forming the terminals of the 100 lines of the group, and the metallic ends of the terminals of the "B" trunk which meet here, coming from the different "pilots" where they had their beginning in shuttles.

All these rods have open branch circuits to the selector; but one of these branches at a time is closed temporarily at the moment the "pilot" establishes connection between an "A" trunk and a "B" trunk. Now, the sender is again released, and the transmission is effected. When the signal has been transmitted, the selector at the "terminator" effects the dropping of that one shuttle which carries the number wanted; and if its corresponding shuttle in the "originator" is idle, it is thus connected with a "B" trunk, thereby establishing connection between two subscribers.

In the other case the "busy" signal is given to the "originator," and the connection so far established is taken down.

Next, the ringing machinery is actuated, causing the signal at the called subscriber's instrument—the signal being repeated usually four times. It may be any number.

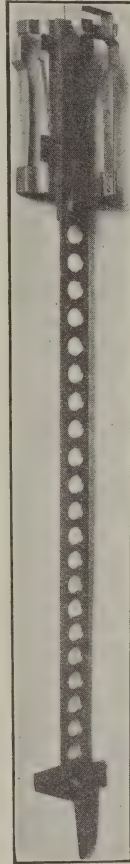

Fig. 5. Subscriber's Unit, New Form of Trunking Operator.

Should the subscriber not answer, the connection is cleared out again.

As soon as the subscriber answers, the ringing mechanism is cut out and the talking battery is thrown in, so that no time is lost. On completion of the conversation the clearing-out magnet with

its parallel resistance clears the line. The comparison as to simplicity of operation in trunked calls is evidently still more in favor of this automatic system than even that shown in local calls—as the following comparison of operations necessary shows.

Automatic.

1. Subscriber sets "sender" and winds it up.
2. Subscriber's shuttle drops.
3. Subscriber's shuttle is lifted into connection with an "A" trunk.
4. Subscriber's "sender" gives the group signal.
5. Pilot drops corresponding "B" trunk shuttle and connects it with "A" trunk.
6. Subscriber's "sender" gives number signal.
7. Terminator drops called shuttle, or, if busy, gives busy signal; otherwise connects shuttle with "B" trunk.
8. Terminator throws automatic key on called subscriber's line, ringing same.
9. Called subscriber and calling subscriber take off receiver.
10. Automatic key is restored, and talking battery throws on the line.

Manual.

1. Subscriber takes off receiver.
2. Subscriber's individual light at exchange lights up above pilot light.
3. Operator places answering plug.
4. Operator varies listening key.
5. Operator asks number.
6. Subscriber gives number.
7. Operator repeats number.
8. Operator presses order wire key; gets into communication with the trunk operator in the central office with which the called for subscriber is connected.
9. Operator gives number of subscriber wanted to incoming trunk operator at the second exchange.
10. That operator repeats number.
11. That operator gives number of idle trunk to be selected.
12. First operator releases order wire key.
13. First operator connects idle trunk to her cord circuit, thereby establishing connection between trunk and calling subscriber.
14. Second operator tests called subscriber's line for busy using the trunk plug.
15. If idle, operator plugs multiple jack with trunk plug.
16. Second operator presses automatic key.
17. Automatic key rings subscriber.
18. Called subscriber takes off receiver, thereby restoring automatic key.

Next, Conversation Begins.

Upon Its Termination,

11. Calling subscriber hangs up.
- Clearing-out magnet drops his connection in originator and pilot.
13. Called subscriber hangs up.
14. Clearing-out magnet drops balance of connection.

19. Calling subscriber hangs up receiver.
20. Supervising lamp at first operator's position lights up.
21. Called subscriber hangs up.
22. Second supervising lamp lights up.
23. First operator pulls out plugs.
24. Disconnect lamps at second operator's position light up.
25. Second operator pulls out trunk plug from multiple jack.

Special Classes of Service.

In modern telephone central exchange practice certain special classes of services are demanded; and these the automatic system already described will take care of in an eminently satisfactory manner; and also adapting itself to the present central energy or common battery system, in a manner impossible with any other automatic exchange.

This system eliminates totally the large force of manual exchange operators, and only in the "toll service" the human operator is for the present essential.

I will consider in turn the manner in which the system would take care of each of these special classes of service:

"Toll Connection."—A special number on the sender will be designated as "toll operator's" number at the exchange, she being called up just as any subscriber is. The operator then asks one what number is wished, and what the number of the calling party is, stating that she will call you when she gets the party you desire. This acts also as a check upon the service, and prevents a dishonest party giving another subscriber's number.

"Restricted Service."—As in manual exchange practice, the toll operator would have a complete list of parties receiving such service, and decline to give

any outsider long distance connection until he has been properly identified.

"Appointment Calls."—As in manual exchange practice, these would be made through the toll clerk, who is communicated with through the operator's number on the sender.

"Automatic Pay-Station Service."—Such service would require a metering device, preferably a nickel-in-the-slot attachment, the nickel being returned in case no service is rendered; or a metering device such as a cyclometer, responding to the action of the receiving hook, but only when circuits are established or service actually rendered. At the central exchange a metering device would be operated in conjunction with the "busy test" apparatus, enabling the operator to check off such service, as in present manual exchange practice.

"Inquiry Calls," "Information Bureau," "Complaints" and "Transmitted Messages."—In addition to the operators in the modern manual exchanges, information men, trouble men, etc., are employed to answer inquiries, attend to complaints and transmit messages. The four classes above mentioned would be attended to in precisely the same manner.

"Party Lines."—A four-party line selective ringing service can easily be given.

Advantages of This Automatic System Over Others.

The following points of advantage which are claimed for this automatic system have been investigated by me, and I deem them well worthy of consideration of every telephone engineer:

It is applicable to an exchange of any size.

It is applicable to the present standard central energy system.

It is applicable to any commercial

telephone, and to the present arrangements of circuits met with in standard practice.

The total elimination of the multiple principle from this system makes it possible to sub-divide the exchange into several separate local exchanges, together forming a large city system, and this without destroying the principle of unity in the system and without decreas-

ing the speed of connection. In this manner a great economy in line construction and maintenance is effected.

It employs the usual protective devices of lightning arrestors, heat coils, etc.

It gives a prompt service, the total time taken to reliably transmit a trunked signal of four figures is about three-fifths of a second, and the average time to secure connection is found to be from three and one-half to four seconds.

It will give a more reliable service and with equal efficiency at all times. Unlike the human operator, it is never impatient or impertinent, and does not become fatigued or ill, and does not drop in efficiency under stress of the rush hours.

The saving of space occupied by this exchange will be very great as compared with the space required for a multiple manual system. I am informed that the lowest calculation for space in cities is about 1,000 square feet per 1,000 subscribers, giving, say, 10,000 square feet for a 10,000-line exchange. And this is a very conservative estimate. In contrast, it is claimed that 100 machines of 100 lines each, with sufficient lane-ways between each machine both ways of, say, two feet, and a center lane of three feet, would only occupy 62 by 55 feet, or in all 3,410 feet.

It will do away with a large corps of skilled attendants at the switchboards, eliminating one of the heaviest expenses attendant upon the telephone industry.

It will do away with a percentage of employees necessary to keep the central station cables, wires and appliances in condition, and lessen the cost of inspection and maintenance.

It is claimed that it can be installed in large and medium-sized exchanges at 30 to 40 per cent. less cost than the present multiple exchange system, and that the contacts in, say, a 10,000 ex-

change would be 80 to 90 per cent. less in number than in a multiple exchange. It is possible to add at any time groups of 100 very easily without disturbing the existing installation, and these increase from time to time in proportion to the demand. It would show much more nearly in a direct ratio an increase in expense of operation and fixed charges with the increase in the number of subscribers than would be possible with the manual exchange, which, as is well known, increases all out of proportion to the increase in the number of subscribers.

It will do away with employees' dressing, dining and reading rooms, clothes lockers, infirmary, matron, etc., as well as considerable expense for ventilating plant, lighting and other sanitary arrangements necessitated by the usual crowding together of a large number of human operators in modern exchanges.

It permits of a large number of subscribers calling simultaneously without producing confusion, the calls being stored up and brought into communication with the exchange in numerical rotation.

It requires a single piece of machinery for 100 lines, in contradistinction to the majority of automatic exchange systems, which require one machine to perform the switching for each subscriber's line.

A most important feature is that it does away with the cords and multiple connections, and, as the ground or drop connection is broken when the subscriber's carriage leaves its position of rest, a perfect balance of circuits is insured, and the absolute isolation of each pair of communicating subscribers.

It gives a continuous trouble test, instantly throwing any line in which trouble has developed, either inside or outside the exchange, into communication with one of the lines, which may be

the wire chief's. A permanent record is also made of these troubles.

It requires no batteries and no extra circuits at subscriber's stations, as in all other automatic systems.

It does not necessitate the subscriber's waiting to hear the operator ask "number?" and repeat same to prevent error, thus saving the subscriber's time on each call.

It provides a "sender" which is "fool proof," it being locked when operating, preventing further interference until signal is sent and properly received at the central exchange.

It does not require extra wiring, or even cutting of subscriber's lines in order to install the sender, there being no mechanical connection of any kind between the subscriber's instrument and the sender, and the sender may be placed at the subscriber's telephone or at any convenient point. It is only necessary to connect it in parallel across the existing line, grounding the third binding post of the sender.

It necessitates no multiplicity of idle wires, crowding and complicating the working space, as in other exchanges, which amounts at times to 25 per cent. or more.

It requires but a single power-driven pulley.

It embodies no parts operating at excessive speeds in the original type of machine, the driving shaft being run at but 250 revolutions per minute, with the operating parts driven by double back gearing at from 12 to 15 revolutions per minute.

It embodies in the mechanism of the original form but four cams on a single shaft, each acting upon rollers, a single cam controlling all movements with the exception of the ringing controller. In the new type of "operator," "sun and

planet" gears take the place of the four cams in the original "operator."

It employs a single carriage, with a connecting rod for each subscriber at central.

It provides a set of metal rods exactly corresponding to the connecting rods of the manual exchange in place of a large number of contacts, constituting a multiple of all the lines in the exchange at each "selector," which is a predominant characteristic in all other automatic exchanges. It is substantially built, with comparatively few wearing parts, and no telephone cords, plugs and jacks, line drops, lamps, relays, etc., to wear out, the cords being especially troublesome and expensive.

It requires but two operating batteries, no matter what the size of the exchange may be. One battery furnishes current to the switching apparatus, the other for conversation. Some automatic systems employ several batteries at the exchange and, in addition, a local battery at each subscriber's station.

It uses less current than the present multiple boards, as only 1 per cent. of the circuits of the exchange when idle receives any current at all, and that for but a fraction of a second. In some automatic exchange systems the current is very considerable as compared with the maximum requirements of the exchange.

It makes and breaks every contact by power. No contact in the exchange is made or broken by means of an electromagnet (on the principle of a relay), not a single relay being employed on the machine.

It can co-operate with manual exchanges, and can call and be called by such exchanges.

It can be completely wired in sections at the factory, with the single exception of the "B" trunks, and at the place of

installation it is only necessary to connect the "B" trunks to the "terminator" and to connect each subscriber's line once, a proceeding which is not possible in any installation employing the multiple system. It employs large contact

surfaces. It handles all calls, no matter how many subscribers call at once. It possesses a perfectly balanced circuit at all times, having no multiple branches or taps. This is impossible with the manual or with automatic systems generally.

Disadvantages of the Manual Exchange System.

Heavy disbursement for operators' salaries.

Important conversation between subscribers may be listened to by the operator and others at the exchange; and although this is not to be feared to any considerable extent in large exchanges, it is, nevertheless, a fact that the absolute privacy insured by the automatic exchange system is highly appreciated by the telephone subscriber. At each call considerable of the subscriber's time is consumed in giving the operator the number desired and having her repeat the same to prevent mistakes, and frequently the subscriber has to repeat the number several times by reason of his or her indistinct speaking or standing too far from or too close to the transmitter, or by reason of disturbances on the line, or interference of other sounds in the proximity of the telephone. There may also be interference due to other subscribers being cut in on the lines.

During rush hours it has been necessary at times to station behind the usual operator special operators, who facilitate the handling of the board by pulling out the various plugs. And it is not an uncommon practice when there are troubles at the switchboard, and possibly even during the congestion of the rush hours, for the operator to report a line busy, thus staving off temporarily the calling subscribers. Circumstances have been known where subscribers have been told repeatedly that the party whom they have called was busy, and, on his making

inquiry at that party's office, he has found that the telephone had not been used during that period.

The reason why the multiple board deteriorates faster than the balance of the installation lies in the fact that practically everything has to be sacrificed to consideration of space. A well-known telephone authority in this country has stated that the allowance for depreciation on the switchboard should not be less than 10 per cent., and, while the common battery board is doubtless much better than the magneto board, it is believed that with this mechanical operator, with its large surfaces of contact and ample mechanical margins, the depreciation could be much less.

The cost of construction where the multiple section system is employed is enormous. It is a fact well understood by experienced telephone men that, as the number of the subscribers which are connected to any exchange (whether manual or automatic) increases, the expense, both of operation and maintenance increases in far greater proportion than the increase in the number of subscribers. This is not the case, however, with this automatic system, which, as regards the central exchange expenses and construction expenses and maintenance charges, increases more nearly in a direct proportion with the increase in the number of subscribers.

The length of reach of the human operator in the manual exchange is very limited. She is generally expected to

cover a section of board 30 inches each side of her. This is not the case with this mechanical operator, the range of which is practically unlimited. Furthermore, in the latter case, the machine is not delayed by connecting and disconnecting, as it can connect and disconnect at one and the same time, a function which is not possible with the human operator.

In considering the disadvantages of automatic exchange systems hitherto invented, it is readily understood why they have met with such limited application up to date, notwithstanding the realization by telephone men the world over, of the many advantages of automatic exchanges; it is because of the inherent delicacy of the various electrical and mechanical devices employed and the rapid depreciation of these devices. It is also due to their extreme complexity, especially in the multiplication in the numbers of wires, contacts, relays, magnets, etc., which increase out of all proportion with the increase in the number of subscribers. It is quite common to employ from five to seven or more magnets and relays in each switching device, and employing one to three of these switching devices in establishing the necessary connections, and utilizing these magnets and relays for performing the actual mechanical work of lifting, rotating and switching the mechanism employed with all the

disadvantages which this entails; and finally, it is by reason of the very high class of engineering talent essential in the designing and constructing of the complicated apparatus which has been employed.

It is self evident to all electrical engineers who have had experience with electro-mechanical devices that it is far better to employ a well designed mechanism performing a definite cycle of operations and driven by some source of power.

This mechanical operator has been designed and constructed upon the following lines: i. e., an absolutely reliable, prompt, rapid and uniform service in telephone exchanges of any size; an embodiment of all essential features demanded by the exigencies of modern telephone practice; an elimination of the unreliable, flimsy and complex features inherent in systems heretofore presented to the public; and finally, the effecting of large economies in construction and maintenance charges.

The author of this paper believes as a result of his investigations into this system, that these claims made for it will be borne out in actual practice; and he considers it a privilege to be able to present for your consideration what he believes to be one of the most important and interesting inventions ever brought before the American Institute of Electrical Engineers.



German Briquette Machinery for America

By FRANK H. MASON

United States Consul-General at Berlin

THE correspondence received during the past month from nearly every State and Territory of the Union, making further inquiry concerning the machinery and processes employed in Germany for making fuel briquettes from lignite, peat, and coal dust, indicates that public interest in the whole subject of utilizing the hitherto wasted or neglected fuel materials, so abundant in America, has been thoroughly aroused. There are in New England, western New York, Michigan, Illinois, Wisconsin, Oregon, and Washington vast beds of peat which have been thus far hardly explored. There are in the Dakotas and the Gulf States large deposits of lignite and material midway in character between lignite and peat, and there are in all the coal mining States enormous quantities of bituminous dust and anthracite culm, all of which may by the employment of modern machinery and processes be added to the fuel supply of our country.

The first tentative efforts in relation to this industry made in the United States have generally failed, but Germany, France and Belgium, by long, careful, scientific experience, have developed an important and successful system of pro-

duction. There is no reason why any American operator or mine owner should risk a dollar in vague or hazardous experiments; he has only to ascertain by expert inquiry what his crude material contains—whether or not it is adapted to profitable conversion into briquettes, and, if so, by what processes and machinery it can be most effectively treated. With a view of answering concisely the latest inquiries on this subject and simplifying to some extent the practical proposition, the following resume of the briquette manufacture, as it exists in Germany, is submitted.

German briquette factories are divided, in respect to the crude material employed, into two general groups—those which make household briquettes from brown coal (lignite) or carbonized peat; and those which produce the so-called “industrie briquettes,” using as basic material coal dust or “slack,” the waste of bituminous coal mines.

I. Household briquettes, as made in Germany from brown coal, peat, and to a small extent from anthracite dust, are used for grates, heating stoves, cooking stoves, and ranges, and constitute the principal household fuel of Berlin and other German cities. They are clean to

touch, kindle readily, burn with a clear, full flame, and are cheaper in Berlin, ton for ton, than anthracite or good bituminous coal. They are made—largely from brown coal—in factories located mainly in Silesia, Saxony, and the Rhine provinces, and united in a syndicate, which controls the output, regulates prices, and looks after the general welfare of the industry.

Machinery for the manufacture of briquettes from lignite is made by several large establishments, among which may be cited the Zeitzer Eisengiesserei, at Zeitz, in Saxony; the Maschinen Fabrik Buckau, at Magdeburg; and the Koenigin Marienhuetten, at Cainsdorf, in Saxony.

The illustration shows a miniature working model of a brown coal briquette factory, which was exhibited by the Zeitz establishment at the recent exposition in Duesseldorf. It exhibits in condensed form the essential elements of such a plant—the machinery for pulverizing; elevating, drying, and finally compressing the material into briquettes.

There are in Germany 439 brown coal mines, which produced last year 44,211,902 tons of lignite, valued at \$46,042,500, or a little more than \$1 per ton. Of this whole number of mines, 181 have each from one to six briquette factories, in each of which from one to ten presses are employed. The whole brown coal briquette industry of Germany includes 286 factories, with a total of 691 presses. Statistics of the total yearly product are not accessible, but from the fact that a single press turns out from 50 to 90 tons per day, it will be readily inferred that the annual output is enormous. They are the standard household fuel throughout a large portion of the country, and are besides largely used for firing steam boilers, especially in cities where their

cleanliness and freedom from smoke and dust are highly esteemed. The standard household briquette is about 8 inches in length by 4 inches in width and 2 inches thick, and it is retailed and delivered in Berlin at prices ranging from \$2 per 1,000 in summer to \$2.50 in winter.

II. Industrial briquettes are used in Germany for firing locomotives and other steam boilers, for smelting in reverberatory furnaces, and for many other kinds of industrial heating. They are made of bituminous coal dust, held together by a matrix of mineral pitch—that is, coal tar derived from retort coke ovens or gas manufacture, and from which the benzole and other valuable elements have been eliminated. Pitch of this quality costs in this country from \$10 to \$12 per metric ton—2,205 pounds. The percentage of matrix necessary to be used varies greatly with the “fatness”—i. e., richness in bituminous elements of the coal itself. Slack from very fat coal will work into briquettes with an addition of 2 or 3 per cent. of pitch, while leaner grades may require 6 to 8 or even 10 per cent., the latter proportion being sufficient, at the present cost of pitch, to render such coal unprofitable for briquette making purposes. Briquettes made from bituminous slack, although not smokeless, are much more nearly so than ordinary bituminous coal. When burned in locomotives or any well constructed boiler or other furnace with a good draft, they create only a thin, translucent mist, which contains relatively little soot, and is very different from the inky clouds that roll up from most factory chimneys where soft coal is shovelled indiscriminately into the furnaces. The one notable defect of such briquettes is that the mineral pitch, which is used as a binder, contains more or less creosote; this renders dust and

fumes from such fuel acrid and sometimes irritating to the skin when confined in a close, hot boiler room. Soft coal briquettes are made from the dust and waste of mines, and, when the composition of the coal is such as to permit a low percentage of binder to be used, they are the cheapest and easiest kind of briquettes to produce. They are made in machine presses.

The output of soft coal briquettes in western Germany is controlled by a syn-

dzial model and 3 so-called "egg rollers," or machines, which produce small, oval briquettes of egg size which are burned in certain kinds of tubular boilers. The syndicate claims a maximum annual capacity of 2,100,000 tons, and, as its official report shows, makes about three-fourths of that amount—whatever the market will take at prices which the syndicate managers consider equitable. Industrial briquettes are usually of a square or oblong form, convenient to be closely

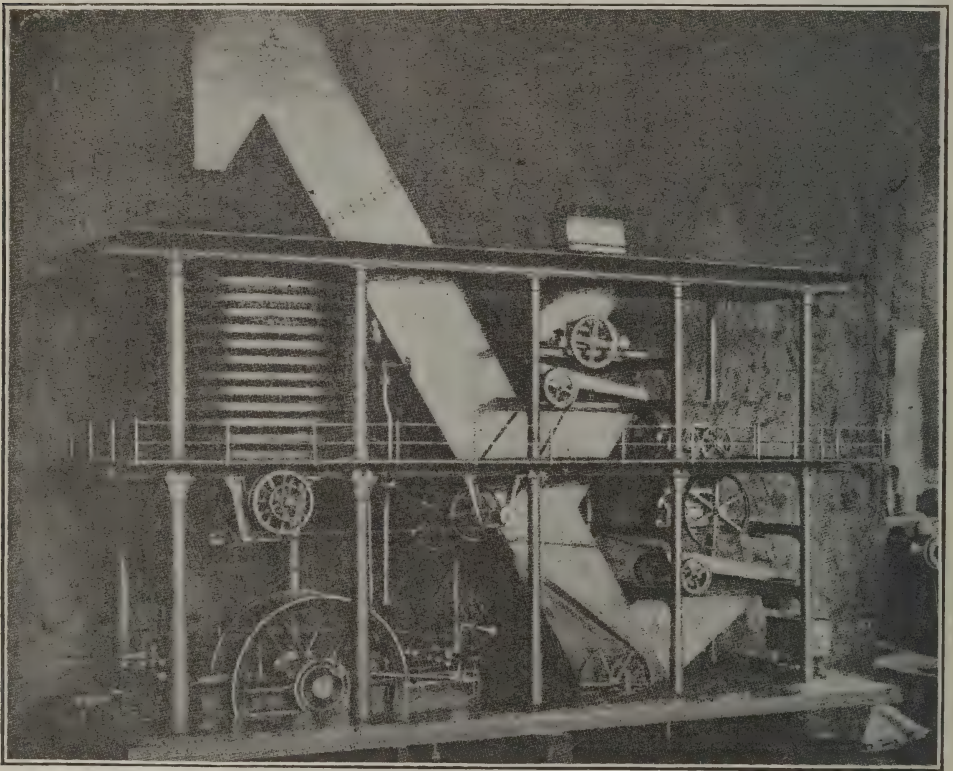

Working Model of a German Brown Coal Briquette Factory.

dicate called the Briquette Sale Syndicate of Dortmund, which includes among its members 31 factories, located in Westphalia and the Rhine provinces. These establishments employ, collectively, 112 machine presses of the Couffinhal type, besides 1 French machine of the Bour-

packed or built up into a wall, like bricks, whereby they greatly economize space as compared with raw coal. They range in weight from 3 to 10 pounds, and each bears the initials or trademark of the company by which it is produced, so that in case of any defect in quality, the

inferior briquette can be readily traced to its source of production. When burned whole, they are consumed slowly and give out a steady, moderate heat for a long time; when it is desired to quicken or intensify the flame, they are broken up, and in this condition are especially adapted to flue or tubular boilers, sugar evaporating, smelting, and annealing furnaces, in glass manufacture, or in porcelain and cement factories; wherever, in fact, a fuel capable of producing a long, fierce flame is desirable. Their efficiency as locomotive fuel may be inferred from the fact that the State railways of Prussia, which used 130,000 tons of such fuel in 1889, have bought from the syndicate 680,000 tons during the first nine months of 1902.

Anthracite coal is so sparingly produced in Germany that the use of hard coal dust for briquette making is relatively unimportant. Experts, however, agree that with an admixture of from 4 to 8 per cent. of matrix, the manufacture of anthracite briquettes, which will bear transportation by sea or land in any climate, presents no technical difficulty.

The manufacture of coke and briquettes from peat or turf is still relatively in the experimental stage, although there are several factories in successful operation, and another—the largest of all—is just being put into operation at Koenigsberg, on the Baltic coast of East Prussia.

The principal peat briquette factory in this country is located near Stettin, and has been in operation several years, and is apparently successful.

III. As a result of the present widespread interest in this subject and the many inquiries that have been received from mine owners and operators for technical information as to processes, cost, and capacity of machinery, etc., a

combination has been formed between three of the foremost machine builders in this country, whose products collectively include all the necessary apparatus for making briquettes from coal dust, brown coal and peat. The purpose of this syndicate is to meet promptly and efficiently the American demand for machinery and working methods which represent the best results obtained by scientific study and mature experience in Germany. The combination is entitled "The Export Syndicate of Briquette Machinery Manufacturers," with central office at No. 59 Friedrich strasse, Berlin, and includes as members the Zeitzer Eisengiesserei at Zeitz, Saxony, the Maschinenfabrik Buckau at Magdeburg, and the Maschinenfabrik (formerly Jaeger) at Ehrenfeld-Cologne. Its plan is to send over, within a few weeks, an experienced engineer, who will establish an office at New York and be prepared to confer with firms and persons who contemplate entering upon the manufacture of briquettes, to examine sites and materials, make plans and estimates for buildings, machinery, etc. An opportunity will be thus offered for American mine owners and operators to ascertain definitely in advance the theoretic value of their materials for briquette making, and the cost of a plant of a given daily capacity.

Meanwhile, the same results can be reached with important saving of time if owners of coal mines or lignite beds will send to the above address, directly, or through this consulate, 10-pound samples of their material in the exact condition in which it will be available in large quantities for practical use. The percentage of water in any briquette material is an important factor in determining how it can best be worked.

If the material is dry—as, for instance,

slack from a well drained bituminous coal mine—the sample may be sent in an ordinary box or package. If, on the other hand, the slack or culm is obtained wet from a washing process, or if the material is lignite or peat from a bog, the sample should be sent in a tight tin case, which will preserve the exact percentage of moisture which will be encountered when it is mined for use on an industrial scale.

The postal-package treaty between the United States and Germany provides for the transmission by post, reciprocally, of packages not exceeding 11 pounds avoirdupois in weight at a uniform rate of 12 cents per pound. Allowing for the weight of the necessary covering, this will enable interested persons in America to forward to Berlin samples of

their material sufficient in quantity to be analyzed, submitted to various tests and even made experimentally into briquettes; so that its adaptability to briquette manufacture, the percentage of binder required, the caloric value of the product, and methods and machinery best adapted to working it can be ascertained and reported on in advance, by responsible experts who are prepared to follow up their estimates by practical operations.

In this way, the technical experience and scientific knowledge which have made the briquette industry successful and important in Germany will be made directly available by American operators who desire to begin at the point of economic efficiency that has been attained by the best practice in Europe.





Digest

Engineering Literature of the Month



Electrical Furnace for Making Steel.

(Electrical Review.)

MR. MARCUS RUTHENBERG, of Philadelphia, recently made a demonstration of his new process for manufacturing steel at the works of the Cowles Electric Smelting & Aluminum Company, West Lockport, N. Y. Mr. Ruthenberg was permitted to erect one of his new furnaces in the plant, and he had invited to be present several independent steel operators. The claim is made that by the use of the Ruthenberg electric furnace the intermediate processes of making pig iron, oxidization, etc., are eliminated or practically combined in the one operation, and that from the raw material fine steel is turned out ready for the market. In speaking of the process, Mr. Ruthenberg said it was not improbable that the independent operators might use it as a weapon to fight the great steel trust. According to the inventor, electricity is, by his process, applied to the smelting of iron ore at about half the cost of the reduction of ore through the blast furnace and steel hearth. The furnace tested that day was unique in that it used only about one-tenth the power formerly used in reducing iron electrically, thus putting it upon a very favorable basis of comparison with the ordinary methods of the blast furnace and steel hearth. The raw ore is first cleaned to the highest degree of purity, reducing material in the form of charcoal or coke dust is incorporated

with the ore, and then it is fed to the electric furnace, producing a reduced fused mass which goes to the open hearth furnace as steel melting stock, saving the ore from going through the blast furnace. This economizes 33 per cent. of the fuel and all of the limestone, and at the same time produces a better and purer quality of steel.

The Point of Cut-off in Corliss Engines.

(The Central Station.)

With a well regulated central station taking its steam at practically a uniform pressure, the point of cut-off on the Corliss engine is a measure of the steam that it takes each stroke in a very accurate meter fashion. This point of cut-off is fixed by the governor balls, and the position of the various rods and levers connected thereto. As a good Corliss engine gives a reasonably constant speed, a record of the point of cut-off throughout a day's run would be a very interesting curve sheet to consider, particularly in connection with the load curve of the generator which the engine is driving. It is not a very difficult matter to arrange to observe this point of cut-off throughout a day's run, and it will give an idea of the performance of the engine which is in some respects superior to the indicator card. A clock driven drum carrying a paper suitably ruled in ordinate and abscissae, the tracing index of which is connected to the governor mechanism, suggests itself as practicable, convenient

and easy to be applied. An indicator card is rather unsatisfactory in some respects, especially when the load is varying. Under such circumstances the governor is dancing up and down and the engine is giving a heavy impulse on its piston one minute and a light impulse the next in the endeavor to keep the speed constant. If the investigator is content to take but one card he may happen to catch a big one and figure out therefrom a gratifying but misleading efficiency of the unit. If he takes ten or twenty cards the result is, of course, better, but he has no guarantee that his card represents the average cut off, for he may have been unfortunate and secured a number of cards which are either too large or too small. It is really better under such circumstances to hold a pencil movement on the indicator drum, take a number of curves one on top of the other, and select from among the many expansion lines which appear as the result that which appears to be a fair average. In reading an ammeter or a voltmeter the observer very naturally records an average reading. In taking a single indicator card he is absolutely ignorant as to whether it represents the maximum or minimum power which the engine of varying output is exerting. Good testing instruments are beautiful and reliable pieces of apparatus, but their uninterpreted indications are often as misleading as the wildest guesswork.

The Relation of Hardening Power to the Magnetic Properties of Steel.

(Metallurgical Laboratory Notes.)

Prof. Henry M. Howe, in describing some experiments made to show the temperature at which steel possesses the hardening power and the relation of this to the magnetic properties, says:

“This series of experiments will show

that steel at a red heat is non-magnetic but has the hardening power; that it loses this hardening power and at the same time recovers the magnetic properties as it cools from a dark red heat down, and that this transformation, while rapid, is not instantaneous.

“If you watch carefully in a dark room, you will see that, as the magnetic properties are returning and the hardening power is departing, the wire brightens perceptibly, owing to the heat evolved by the molecular transformation which is occurring. This brightening is known as the recalescence.

“Note that in order to harden the wire at all it is necessary to heat it in the first place to a temperature considerably above that at which it loses the hardening power in slow cooling. In other words, the hardening power is acquired at a temperature higher than that at which it is lost in slow cooling.”

Increasing the Revenue of a Telephone Exchange.

(American Telephone Journal.)

Under this caption Mr. N. H. Holland answers the question as to whether there are means of increasing the line revenue. The average length of conversation as given by the last report of the Bell Telephone Company is a trifle over two minutes, and the average number of connections for each telephone about eight per day. This means that each instrument is in use less than half an hour of the twenty-four. Although on some lines the time of use is much greater, the fact remains that the vast network of wires required in a moderate telephone plant is idle a large proportion of the time. The problem is to increase the earning power of this expensive plant without interfering with the regular service, and the author makes a few suggestions as to how this may be done.

One scheme is to wire subscribers' houses with thermostats and charge a certain sum for fire alarm service, utilizing the regular telephone line wires to convey the signal to the central exchange.

The Western Union Telegraph Company adds to its revenue by the sale of standard time. Could not telephone companies also furnish similar service? Small clocks could be furnished to each subscriber, controlled by a master clock at the central office. There are several such systems now on the market; and to operate the clocks over a telephone line is not a difficult proposition.

Possibly a lesson can be taken from our friends in the street railway business. A great many of our trolley roads have established parks at the end of the route, where some form of entertainment is given. These parks are often free, but sometimes a nominal fee is charged, the main object being to increase travel on the road. Could not the telephone companies, by establishing a concert room, where instrumental and vocal music would be rendered, and to which subscribers would be connected for a small toll, gain a similar advantage in their business. Loud-speaking receivers could be used and music delivered vastly better than from any form of "talking machine." The tremendous number of these latter instruments that are sold indicate that such a form of entertainment is appreciated by the public.

A form of increasing telephonic revenue has been quite successfully tried in Germany. This consists in furnishing the subscribers with telephone news service. Persons with the ability to read clearly and distinctly are selected to read the daily news through powerful transmitters during certain hours of the day. Any subscriber desiring to receive the news, places the receiver to his ear, and

can comfortably enjoy the latest sensations without reading them himself.

However, in the writer's opinion, the more direct way of using the telephone would be by an improved manner of handling calls when the line required is found to be busy. The "busy line" question is perhaps the most difficult one encountered in telephone practice, and how it could be overcome would be as follows:

The operator, upon finding a desired line busy, would, upon advising a subscriber of the fact, ask him if he wished that line as soon as it was disengaged. Then, by attaching a connection to the busy circuit of both the calling and called for lines, which circuit would contain a special signal to be displayed as soon as the test current was removed from both lines, or when they were both disengaged, she would have an automatic memorandum of the desired connection, which would compel her attention as soon as the lines were in condition to be connected; and she would then ring up both parties and complete the connection. This would mean some special arrangements, and in a large exchange the "stored call" should be handled by an operator exclusively retained for that work. As the circuit would be local, however, it could be applied to any of the existing systems. With measured service, a method of handling all calls until a complete connection is obtained becomes of greater importance. That something will have to be done to modify the nuisance of finding the line continually busy when wanted, is universally recognized.

Electrical Statistics of Twelve American Cities.

(Western Electrician.)

Hugo S. Grosser, City Statistician of Chicago, has prepared a statistical table with copious notes, giving valuable and

interesting data on the cost of administration of twelve American cities. The twelve cities selected are: New York, Chicago, Philadelphia, St. Louis, Boston, Baltimore, Cleveland, Buffalo, San Francisco, Cincinnati, Detroit and Milwaukee. In the mass of information the figures relating to New York and Chicago, given under the head of "Electricity and Lighting," will be of interest.

In New York City the Department of Public Buildings, Lighting and Supplies has charge of the City Hall, courthouses, public baths, and other municipal buildings (not including police, fire, or schoolhouses), bureau of electricity and bureau of public lighting. The salaries for 1901 (\$631,240.86) were for administration, clerks, janitors, cleaners, bath attendants and other employes. The expenses for the year were \$3,513.15, while for supplies and repairs to various offices and building, the department expended \$406,250.87 additional. The cost of lighting for the year was \$2,243,468.91.

The Electrical Department of Chicago is in charge of lighting streets, electrical inspection and police and fire-alarm telegraph. The salaries for 1901 were \$11,362.85 for administration; \$17,318.59 for electrical inspection; \$12,468.61 for gas inspection; \$8,452.76 for superintendence, etc., of electric light system; \$13,368.58 for lamp repair shop, and \$32,308.72 for operation of city plants, a total of \$95,280.11. The expenses include \$91,112.78 for repairs, renewals, trimming, etc., electric light system; \$5,513.60 for material and supplies of lamp repair shop, and \$114,602.24 for operation, maintenance and repairs of city plants, and amount to \$211,228.62. The cost of lamps and lighting was \$288,830.64 for gas; \$144,855.84 for gasoline, and \$68,794.50 for rented electric lights, a total of \$502,480.98. Expenditures for

extending municipal lighting system, \$52,522.44, were not included in this figure. The salaries for police and fire-alarm telegraph were paid by those departments. The expenditures for operation, repairs and construction of telegraph systems were \$72,588.09.

Testing Pipe-Coverings Electrically.

(Electrical World and Engineer.)

Mr. H. G. Stott explains a method of testing pipes electrically. A heavy current of electricity is sent through the pipe, and after a sufficient time has elapsed for steady conditions to be attained—about ten hours—the energy lost in watts is measured for the tested sections. This energy obviously represents the rate of loss of heat which is always in progress from that section of pipe. The temperature of testing was 350 degrees Fahrenheit, and a second series of tests was made with the current increased so as to give a rise of 50 degrees Fahrenheit to the least efficient covering. The readings were reduced to the basis of heat lost per square foot of pipe surface, and a considerable number of different coverings were tested, which gave an economy of 78 to 89 per cent. over bare pipes, according to thickness and material. The magnesia coverings appeared on the whole to be the best; they also appeared most regular in giving an increased economy, which varied with the square root of the thickness. Absolutely the best covering was carbonized silk. The conclusion to be drawn generally is that a good one-inch covering may lose about 2 B.Th.U. per square foot of pipe per minute, and about $1\frac{1}{2}$ B.Th.U. for two-inch thickness. The figures may be equated with first cost, and the saving that is commercially possible may be estimated. Obviously for temporary work

a covering must be thinner than when years of life are called for. The square root rule points out that a limit of thickness is soon reached. It is shown that if a covering is guaranteed to last ten years it will pay to put it on three inches thick, whereas for a two years' temporary plant a thickness of one inch need not be exceeded.

Making Brass and Silver Out of Lead.

One James H. Duffy, who seems to be a genius in his way, has been making a number of surprising scientific discoveries in his little shop at Hadley's Lake, Me. Not satisfied with welding copper and tempering lead, he has now discovered a process by which, as he claims, brass can be made from cheaper metals. The alloy that he uses contains about 75 or 80 per cent. of lead, and after passing through the Duffy process it not only has the appearance of brass, but it can be used for all the purposes to which that metal is usually put. He declares that by this process brass can be manufactured at about 20 per cent. of the ordinary cost of that metal.

A representative of the metal market, states the "Engineering Review," realizing the importance of this discovery and what serious results it would have upon the metal market, wrote to Mr. Duffy, asking him to give him for publication some details of his discovery.

The following ingenuous reply was received:

"Gentlemen I temper any Kiends of metals I make Brass out of lead and silver out of lead and I am now gone to try the lost art on Glass your Respectfully

"J. H. DUFFY, Machias, Me."

The American Institute of Electrical Engineers at the St. Louis Exposition.

At a recent meeting of the board of directors of the American Institute of Electrical Engineers the following preamble and resolutions were adopted apropos of the general exhibit to be made by the electrical associations of America and the proposed international congress of electrical engineers, to be held in connection with the St. Louis Exposition:

Whereas, The council of the American Institute of Electrical Engineers recognizes that the universal exposition of 1904 will be a most potent factor in extending and promoting cordial relations between the electrical engineers of the world and in advancing the general welfare of the electrical engineering profession; and,

Whereas, The council of the American Institute of Electrical Engineers is deeply interested in the success of the electrical features of this exposition, and especially in the matter of promoting a general exhibit by the electrical associations of America and in the international congress of electrical engineers;

Resolved, That a committee of five members of the Institute be appointed by the president of the universal exposition of 1904, to have general supervision of the Institute's participation in the exposition, and to advise the council with reference to the plan and scope of such participation.

Professor—Mr. Smith, does the human body conduct electricity metallically or electrolytically?

Mr. Smith—Metallically.

Professor—You must be thinking of a man with an iron constitution.—*The Wisconsin Engineer.*

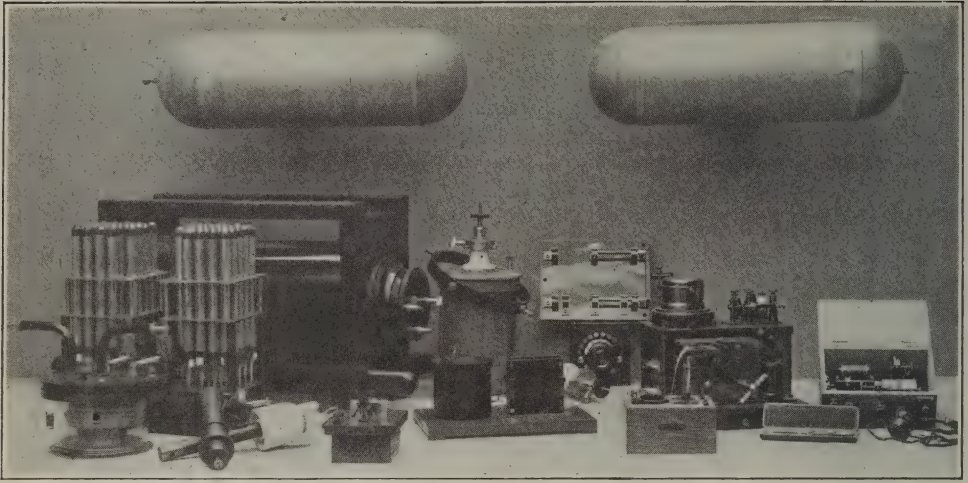

A Complete Braun-Siemens-Halske Wireless Telegraph Outfit.

Wireless Telegraphy in the German Military Maneouvers

By FRANK C. PERKINS

THE Braun-Siemens-Halske system has recently been greatly improved by Professor Ferdinand Braun, of Strasburg University, and several new stations have been constructed. This system has also been used by the Austrian and Danish navies and has recently been thoroughly tested at the last imperial manoeuvres of the German army. The royal airship battalion equipped two military stationary wireless posts, and three portable outfits for army use were also in operation.

Professor Braun, it is claimed, has discovered a means of projecting an almost unlimited volume of electricity into

space, the electric waves affecting apparatus at the receiving station almost any desired distance away, while greater accuracy is attained in the transmission. It is also stated that the attunement of both the receiving and transmitting instruments is such as to provide absolute secrecy in connection with the messages sent.

In the military portable wireless outfits which are provided in army wagons drawn by six horses, a cabinet is fitted on each axle, one being used for the receiving and one for the transmitting apparatus. The aerial wires are provided by means of kites and also small

balloons when so desired. In the rear section of the military wagon are located the source of electricity, the coil, key and other sending apparatus. Constant daily communication was kept up between military headquarters and the army and cavalry corps, and both the telephone receiving apparatus and Morse recording apparatus were employed during the manoeuvres.

The new wireless stations installed with the Braun-Siemens-Halske apparatus are at Sassnitz in Ruegen and the Gross Moellen Post on the Pommeranian coast. This distance is 165 kilometers, and the masts employed are 50 meters high, to which a wire 75 meters in length is attached, the upper third of which consists of a net or group of 6 parallel conductors.

Besides the wireless posts at Hochbahn Station and the station at Markgrafenstrasse in the Siemens and Halske works, there are also in operation the stations at Cuxhaven, Lightship No. 1 and Heligoland. The distance between Cuxhaven and Lightship No. 1 was 33 kilometers during experiments, and between Lightship No. 1 and Heligoland, 32 kilometers; while between the latter station and Cuxhaven the total distance was 65 kilometers. All communications were received with perfect clearness, and Pilot Inspector Kordell reports that the wireless operations between the Elbe Lightship No. 1 and the pilot watch houses have continued without interruption in all kinds of weather for the past six months.

The electric waves are brought into the stations from the aerial wires on the masts through hard rubber insulating tubes, placed in the window, by a well insulated copper conductor, connected with the terminal of a double throw switch, which allows the sending or the

receiving apparatus to be connected. The transmitting and receiving apparatus in the stationary posts is grouped upon and under a table or shelf; the marble or slate switchboard is mounted on the wall in back of the table, and is equipped with the necessary fuse boxes, ammeters, voltmeters, pilot lamps and switches necessary for manipulating the 110 volt direct current or other source of current utilized.

The transmitting apparatus consists essentially of two groups. The inductor with its auxiliaries and the circuits of oscillation.

The inductor differs considerably from the ordinary inductor in construction, its aim being to produce not so much the high tension of the ordinary spark inductor as a large current output. With this special inductor it is possible to charge much larger capacities in a shorter time interval than was formerly possible with the ordinary form. The practical difference in construction consists in employing a special iron core, a considerably larger primary, and a much shorter and heavier wire for secondary than in the ordinary type. In order to obtain a large charging power in the smallest time interval, the ohmic resistance of the secondary must be kept low. Further, in this construction, in which the C^2R losses are not prejudicial, an insulation more than double that of the ordinary type is obtained, so that the coil will work even in very damp places. The primary is interchangeable and is fitted with three terminals, giving different lengths of primary for different interruptors.

In the illustration will be seen a special form of Wehnelt electrolytic interruptor. The upper part of the platinum pole above the surface of the liquid is protected from acid vapors by inclosing

it in a porcelain tube. This prevents the explosions due to sparks in acid gas, which were formerly very common.

Owing to the strength of current employed, the Morse-key has had to be considerably modified. The illustration shows a Morse-key so modified, and capable of interrupting a current of 50 amperes without damage to itself. The platinum contacts are much larger in size, and the key is fitted with a magnetic blowout, which quickly extinguishes the spark and so prevents damage to the key.

To obtain at the same time the highest resistance and the maximum capacity in the smallest possible space, the tube form of jar was chosen. The tubes are made of the best glass, about 25 millimeters in diameter and $2\frac{1}{2}$ to 3 millimeters thick, and their capacities vary from 0.0004 to 0.0005 micro-farads. Spare tubes are furnished with each set of apparatus, if for any cause one or more of the tubes have to be replaced.

The primary of the transformer consists of a few turns of thick insulated copper wire and possesses such a self-induction that, together with the capacity described above, the desired period of oscillation is obtained. The secondary coil is of such length, size and inductance that, together with the aerial wire employed, the highest possible resonance is obtained. As very high tensions are used (although quite harmless on account of the high frequency), the transformers are inclosed in a glass cylinder containing insulating oil.

When the maximum resonance is obtained this transformer is a powerful multiplier (Tesla effect), and produces a high tension which gradually increases to the extremity of the aerial wire where it is a maximum (Ferranti effect).

The opening wire, which is necessary in order to restore symmetry, is conveniently replaced by a capacity, which usually takes the form of concentric cylinders. A switch is arranged to connect alternately the aerial wire with the transmitting or the receiving system.

As such high tensions do not occur in the receiver, the condenser can have much smaller dimensions than those in the sending system. The illustration shows the style of receiving system which is used at present.

The coherer consists essentially of an ebonite tube, containing hardened steel particles of a uniform size in the adjustable space between two polished steel electrodes.

It is not known whether a vacuum adds to the reliability of a coherer or not. At any rate, it is certain that once an evacuated coherer loses its sensitiveness it is of no further value. The coherer can be restored to its original condition at any time by the renewal of the steel particles.

It is well known that the coherer becomes magnetic in use, and that while a small amount of magnetism increases its sensitiveness, too much renders it over-sensitive and hence unreliable. To obtain the advantage of a small amount of magnetism and obviate the disadvantage of too much of it, a permanent ring magnet is employed.

The foregoing apparatus is employed exclusively with the Morse register. In cases where a record is not wanted, where syntonizing is not essential, and for extreme distances, the microphone is employed with telephonic reception. The microphone consists of a steel disc pressed against a carbon or steel point. By means of a screw the pressure of the disc on the point, and hence the sensitiveness of the microphone-hearer, can be varied at will.

The Braun-Siemens-Halske wireless telegraph system consists essentially in the use of a closed circuit of oscillations, which may, by a proper choice of self-induction and capacity, be adjusted to a strictly determined period of oscillations in either direct or indirect connection with an open resonator. In this way a transmitter is obtained which only sends out waves of an exact and known length, and a receiver, which responds far better to this particular length of wave than to any other. In order to make the inten-

sity of the waves as great as possible, it is endeavored to obtain exact symmetry between the circuits on either side of the resonator. This symmetry is observed in the transmitting as well as in the receiving apparatus; so that in this system there is no need for a ground connection as required in all other systems. The abolishing of the ground connection is of great importance, as in this way practically all atmospheric disturbances are avoided. This fact has been confirmed by experiment.





Niagara Falls Under Searchlight.

Searchlight Projectors

THE electric searchlight projector, which was introduced soon after the arc lamp, has made steady and rapid progress. Each of the minute details has been perfected for the special work it has to perform until the modern searchlight is an instrument of great power and accuracy and of almost inestimable value to navigators.

The General Electric Company, of Schenectady, N. Y., has recently designed and placed upon the market a new line of projectors, including projectors with mirrors ranging from 9 inches to 36 inches in diameter. These projectors combine all the latest improvements

of this class of apparatus, and are strongly built to withstand the severe usage which all marine apparatus is subject to in practical operation; yet they are compact and graceful in appearance.

The projectors are of two types: first, those built for the United States Government, which are manufactured under the most severe and exacting specifications; second, those built for commercial use.

All commercial projectors, and those under 18 inches of the United States Government type, are fitted with Mangan ground glass silver-plated mirrors. This type of mirror has two spherical

surfaces of different radii, and the reflection and refraction of the glass cause the rays of light to be reflected in a parallel beam when the arc is in the focus.

All Government projectors of 18 inches and over are fitted with parabolic

consequently more penetrating than that of the Mangin mirror; however, the Mangin mirror is eminently satisfactory for all the work which the smaller projectors are required to do. In view of the high cost of parabolic mirrors, the



Toronto City Hall With Ten Thirty-Inch Projectors, Duke of York's Visit.

ground glass silver-plated mirrors. These mirrors have true parabolic surfaces, and are specified as standard by the Navy Department.

The quality of the light from the parabolic mirror is somewhat whiter, and

Mangin mirror has been adopted for the commercial type of projectors.

The lamps used in these projectors are all of the horizontal automatic type. These lamps are fed automatically, both carbons being fed at the same time, and

the feed is so proportioned that the arc remains in the focus of the mirror until the carbons are entirely consumed.

The design of these lamps is such that the greatest possible amount of light is thrown on the reflector, and the screen shutters, with which the lamps are fitted, prevent the direct rays of light from leaving the projector, consequently all rays of light are reflected and sent out parallel.

The carbon holders or carriages are designed for vertical and horizontal adjustment of the carbons, and by means of a magnet fastened on the inside of the projector and surrounding the arc on all sides but the top, the arc is kept in the center of the carbon and in the focus of the mirror. This magnet is not furnished in the 9-inch and 13-inch projectors, for with the smaller size carbons used in these projectors this device for centering the arc is unnecessary, as the arc on any part of the smaller carbon will be in the focus of the mirror.

A very necessary feature in the proper operation of searchlight projectors is the quality of the carbon used. The best results are obtained by the use of hard, homogeneous carbon of the best quality. Soft carbons fuse and make "mushrooms," which cut out a large portion of the light and prevent the arc from burning steadily.

These projectors are all designed to operate on direct current incandescent lighting circuits. To make this possible requires the use of a rheostat, which is placed in series with the lamp and reduces the voltage of the lighting circuit to the proper voltage of the projector, which varies from 40 to 60 volts, according to the size of the lamp and current consumed.

These rheostats are all made of iron-clad cards wound with German silver,

and can be furnished for any voltage not exceeding 125 volts.

The method of controlling the searchlight projectors is a very important item. The projectors referred to in this article are furnished with either hand or pilot-house control, for sizes up to and including the 18-inch projector; hand, pilot-house, or electric control for the 24-inch projector; and either hand or electric control for the 30-inch and 36-inch projectors.

The beam of light from the hand-controlled projector can be trained vertically or horizontally by the operator standing at the projector and moving the barrel in the desired direction with the handles. A star wheel, mounted on the arm, clamps the quadrant part of the trunnion and acts as a locking device by means of which the barrel of the projector may be held at any desired angle.

The pilot-house control projectors are mounted on the top of the pilot house and operated from within. Both horizontal and vertical movements of the beam of light are accomplished by means of the same lever, which is located conveniently within the reach of the pilot. By a simple locking device, this projector may also be locked at any desired angle.

Electrically controlled projectors may be operated from a distance. They have electric motors mounted in the base of the projector, one motor operating a train of gears controlling the vertical movement, and the other motor operating another train of gears controlling the horizontal movement of the projectors. These motors are regulated by a controller conveniently located and connected to the projector by a six conductor cable. This controller is of such a simple nature and so easily handled that it can be readily operated by a child.

The movement of the beam of light corresponds to the movement of the handle of the controller, and both horizontal and vertical movements can be obtained at the same time. On releasing the handle of the controller, it is brought back to the neutral position, short circuiting the armature of the motors and holding the projector locked in position. An electrically controlled projector can also be operated as a hand control, by releasing the clutches connected to the motors in the base of the projector.

The searchlight projector has played an important part in revolutionizing modern warfare. No other branch of the navy or coast defense has kept pace with the searchlight projectors. The rays of light thrown by these projectors are used for signaling a distance of from 80 to 100 miles, while the range of the largest gun is only from 20 to 25 miles.

Some years ago a 24-inch projector on Mt. Washington was used for signal-

ing weather reports to Portland, Me., a distance of 80 miles; and at the time of Admiral Dewey's reception in Vermont a smaller sized projector on Mt. Mansfield, a distance of 30 miles from Burlington, threw a light into Burlington sufficient to dim the arc lamps.

One of the General Electric 18-inch projectors is installed on the Diamond Sholes lightship, and throws a beam vertically, so that an approaching ship may obtain its magnetic bearing, which it could not do if the beam was displayed at an angular position. This vertical position is not the best for long visibility, but it can be readily seen at a distance of from 30 to 35 miles.

It was reported by officers of the South Atlantic squadron that the searchlight situated at Key West, Fla., had been seen at a distance of 90 miles, and at another time the same light was seen at a distance of 120 miles. In both instances the light was distinct enough for the transmission of signals.



A Row of Projectors Ready for Shipment.



Current Engineering and Scientific Notes

Abstracts from the Foreign Papers



The Water Powers of Switzerland.

(*L'Electricite.*)

M. Thormann has recently investigated the possibility of obtaining from waterfalls the electric power required to operate all the railroads of Switzerland. He finds that, although the complete substitution of electric power for steam is possible, the change would not bring about an appreciable decrease in the actual cost of operation. At present the five principal railroads of Switzerland require a daily motive power of more than 30,000 horse power. To organize a general electric service, it would be necessary to have available high-tension alternating currents of an appropriate power of 60,000 horse power, besides an indispensable reserve. Without taking into account the numerous waterfalls which have so far not been utilized, there are on Swiss territory 21 large stations, producing sufficient energy to furnish at present 86,000 horse power. Among them are the Siel and the Lanfenburg stations, each of 20,000 horse power, and those of St. Moritz, of Nangen-sur-Aar, of Bernan, and of Voeggisthal, each of 5,000 horse power. These 21 stations would of themselves be more than sufficient to distribute the necessary power to the Swiss railways. The cost, however, of the conversion of the railways to electric traction would amount to nearly \$32,500,000. The adoption of electric traction would have the advantage of doing away with the present

consumption of coal, now imported from other countries, and the use of electric power would encourage the development of several national industries.

Receiving Device for Wireless Systems.

(*Electrical Engineer, London.*)

An ingenious device for getting rid of outside disturbances when receiving wireless telegraph and telephone messages has been devised by Mr. J. J. O'Connell, a telephone engineer. The current from the ether or earth, as the case may be, is received by the collector, and, flowing to the condenser, charges one plate of the latter positively and induces an opposite charge on the plate connected to earth, or vice versa. The condenser is then discharged through a telephone or other receiving instrument, and the amount noted. When a receiver is used the volume of sound is noted. The sound produced by the ordinary atmospheric charge is shunted out through a variable resistance, so that only charges produced by current from wireless signal stations may operate the receiver. The inventor says it is surprising the amount of charge which can be collected from the atmosphere with a simple apparatus of this kind. The receiver alone will, perhaps, not detect it, but by placing an accumulator or condenser only in the circuit, and allowing it to charge, then suddenly discharging it, a result is produced which can be

readily detected. Then, by altering the variable resistance until the effect is overcome, the collecting system is placed in such condition that messages may be easily received. Any ordinary form of circuit interrupter may be used, and a speed giving 25 contacts a second has been found desirable.

The Velocity of the Roentgen Ray.

(*Comptes Rendus.*)

M. Blondlot, a noted French savant, in some recent experiments demonstrated that the velocity of Roentgen rays is equal to that of light. He took advantage of the fact that Roentgen rays dissociate the molecules of air through which they pass, thereby increasing its conductivity, in order to determine their velocity. The rays were caused to act upon the spark gap of a Hertz resonator, excited by another spark gap, in parallel with and lying between the focus tube and an induction coil. By suitably regulating the spark gap of the exciter it is possible to make the focus tube and the exciter work simultaneously, but the focus tube is extinguished immediately after the spark begins to pass, owing to the fall of potential between the leads. The electromotive force at the spark gap of the resonator is a quarter period behind the current in the exciter, and, consequently, it is necessary to delay the extinction of the Roentgen rays at the resonator gap if they are to have any effect in making the spark brighter. This may be done in two ways: (1) by increasing the distance between the resonator gap and the focus tube; (2) by increasing the length of the wires conveying the current waves between the exciter and the focus tube terminals. In the first case the delay in the extinction of the Roentgen rays at the resonator gap is due to the time required by the rays to pass

from the focus tube to the gap. In the second case the delay is due to the time required by the electric waves to pass along the wires from the exciter to the focus tube. M. Blondlot adjusted the length of the wires and the distance of the focus tube till the maximum brightening of the resonator spark was obtained. Then he lengthened the wires and reduced the distance of the focus tube till the maximum brightening was again obtained. If the velocity of the Roentgen rays is the same as that of the electric waves in the wires, then the increase of the length of the wires should be the same as the reduction of the distance of the focus tube. Numerous experiments made by M. Blondlot showed these two distances to be practically equal. This shows that the velocity of Roentgen rays is the same as the velocity of Hertzian waves in a wire, and the latter is known to be the same as the velocity of light.

Preparation of Metallic Calcium by Electrolysis.

(*Zeitschrift fuer Elektro-Chemie.*)

A simple process is described by Messrs. Barchers and Stockem for winning metallic calcium by igneous electrolysis of its chloride or fluoride at a temperature above the melting point of the salt but below that of the metal itself. The apparatus consists of a cylindrical cell built of dovetailed carbon blocks, with a bottom made of some good heat conductor, insulated from the sides by means of a covering of fire clay or the like. Centrally from the base an iron wire projects upward nearly to the top of the molten electrolyte, the wire serving as cathode, while the carbon walls of the cell are the anode. This method of construction was adopted because it was found desirable to have the anode as large and the cathode as small

as possible. To make the cell tight it is rammed with calcium fluoride, or fluor-spar, and then charged with calcium chloride. Three small carbon pencils are laid horizontally and symmetrically from the point of the iron cathode to the sides of the bath, and the current is turned on, pushing the temperature till the calcium chloride melts, which is at a moderate but distinctly visible red heat, the rods being then removed. The calcium chloride dissociates, and the reduced metal collects round the apex of the cathode as a sponge, which does not fuse because the temperature is insufficient. If the sponge is lifted out as it is and quenched in some liquid containing no oxygen—rock oil, for instance—a product is obtained which contains about 50 or 60 per cent. of metal. But if the crude material is well squeezed while still in the bath by means of a pair of previously heated tongs of suitable shape much of the calcium chloride mechanically retained can be removed, and, when cold, a fairly compact metal is won, which contains about 90 per cent. of elemental calcium. This 90 per cent. metal can easily be refined by melting it in the absence of air, when, after cooling, a red crystalline layer above the purified metal is recovered. These crystals have been examined by Klockmann, who finds them to be perfectly transparent, and to have a pale red or deepish violet color, due to interference of light. They belong to the mono or tri-clinic system of crystallization, take up hydrogen from the moisture of the atmosphere, and eventually are converted into a mixture of calcium chloride and calcium hydroxide. Analyses of the pure crystals give figures for the chlorine content, which show them to be a calcium subchloride, CaCl . Calcium fluoride may be used as the electrolyte instead of calcium chloride, if preferred.

High Temperatures Determined by an Electric Lamp.

(*Electricity, London.*)

One of the latest uses to which the electric incandescent lamp has been put is as a pyrometer, and it has been found extremely useful for the determination of high temperatures in furnaces, etc. The complete apparatus consists of a telescope mounted on a tripod at a comfortable distance from the furnace, or source of heat, whose temperature it is required to investigate, and adjusted at such a height that its axis is in a line with an aperture in the wall of the furnace. A small incandescent lamp, lit by two or three dry cells, is located in the body of the telescope, an ammeter and rheostat being included in its circuit. The principle of working the device is founded upon the fact that, when the color or state of incandescence of the lamp filament is equal to that of the fire brick, or other heated backing of the furnace, the filament itself, as viewed through the telescope, against this background, becomes invisible. With the aid of the rheostat the current through the lamp is, therefore, regulated until this apparent disappearance of the filament takes place. The current then passing through the lamp is noted on the scale of the ammeter, and, by direct comparison with a special table, gives the required temperature. Repeated trials of this device have amply demonstrated an extreme accuracy of measurement, a valuable trait which is further enhanced by the great simplicity of the arrangement. Its maximum limit of measurement is 3,600 degrees F.

An English Ferry Bridge.

(*London Electrical Engineer.*)

Some time ago "The Electrical Age" published an article regarding the building of a ferry bridge—or trans-

border, as the French term it—across the East river, in order to somewhat alleviate the congested traffic across that body of water. The success this type of bridge has met with in France led to its investigation by Continental engineers and municipalities. A bridge of the trans-border type is now being constructed across the Mersey, in England, between the towns of Widnes and Run-corn, the promoters of the scheme having been authorized to carry it out by Parliament two years ago. The span between the two main towers, rising 190 feet above high-water level on either side of the river, will be about 1,000 feet, over which distance the transborder car will operate. This car consists of a platform 55 feet long by 24 feet wide, and is suspended from the overhead rails upon which the trolley will run by steel wire ropes, so hung that they prevent either side or end oscillation of the car. It will be driven by electricity, and will be capable of holding at one time four two-horse wagons (loaded) and 300 passengers. On the top of the car is located the operator's cabin, whose duty it will be to have the car under such command that he will be able to avoid passing

vessels, as the bottom of the car will only be about 12 feet above high-water level. The time occupied in crossing will be about two and one-quarter minutes, which will allow of some nine or ten trips being made per hour. The bridge, approaches and car will be illuminated by electric light.

Cellulose as an Insulation for Wire.

(Electricity, London.)

It is claimed that through the use of cellulose as an insulation for wires many objections which have heretofore applied to that type of insulation are obviated. The resistance value of the material insulated is more than doubled, and any degree of flexibility may be reached by mixing finely divided sulphur, preferably flowers of sulphur, with dissolved cellulose and then subjecting it to heat, preferably with the aid of pressure. Besides the above advantages, the degree of flexibility can be regulated in accordance with the percentage of sulphur added, and the sulphur adds the valuable property of a greater degree of resistance to the action of acids or of moisture.



Electrically Lighting Trains from the Axle

ELECTRIC train lighting may be accomplished by any one of three ways. A generating plant can be installed in the baggage care, or on the locomotive taking steam from the locomotive boiler. This system, so far as an entire train is considered, is satisfactory, but in railroad operation it is desirable to have each car a complete unit in itself, a condition not fulfilled here.

Accumulators may be carried on each car, rendering each car independent, but it is difficult to provide for changing the accumulators at a sufficient number of points, and it is generally impossible to depend upon charging the battery without moving it from the car.

The third system, and the one which seems to promise best, consists of a small generator driven from the car axle and a suitable accumulator which the former keeps charged. The accumulator is, of course, to supply light when the car is not running.

Although it seems a simple proposition to drive a dynamo from the car axle, there are some serious difficulties. Incandescent lamps require a constant voltage, independent of the speed of the car. The accumulator must be automatically cut out when the speed of the car reduces the voltage below that re-

quired for charging. The method of driving must be absolutely reliable, for it does not do to depend upon frequent inspection. The connection of the generator to the batteries must be changed automatically when the direction of the motion of the car is reversed. All of these points are well taken care of in the system described in this article.

The Moskowitz system of railway train lighting developed and built by the United States Light and Heating

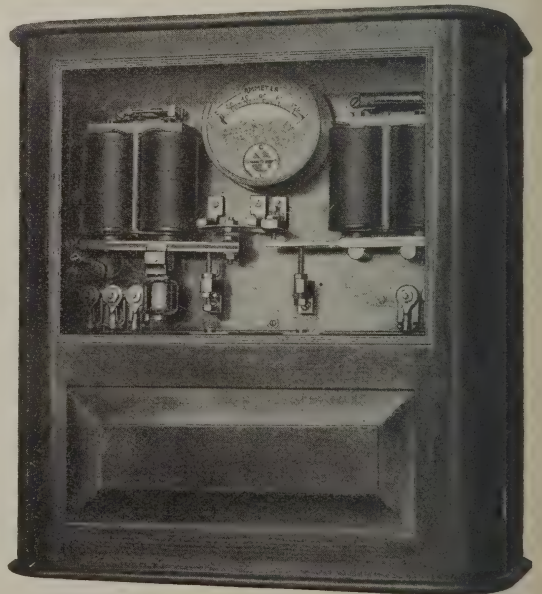

The Motor-Generator Set and Controlling Apparatus.

Company, consists of a small substantial generator, driven by a belt from the car axle, an automatic pole-changer for making the proper connections between the generator and the battery, a suitable battery of accumulators and an automatic regulator for maintaining a constant voltage.

The generator is a small four-pole machine. The field has a cylindrical form and is a solid steel casting. The field coils are wound on brass bobbins and carefully corded. The drum armature is covered with form-wound coils. But two brushes are needed, and these are held in convenient positions for inspection, on the ample commutator. All parts of the generator are interchangeable; the commutator can be slipped off the shaft for renewal, and the shaft itself can be removed from the core. The machine is inclosed, preventing dust or moisture from reaching the interior.

An important point is the method of suspension which must be of such character as to prevent injury to the generator from shocks and jars. In this system this is well taken care of by hanging the dynamo from the car sills by a stout piece of shafting which is itself supported on springs. The generator

swings from this shaft as a pendulum. Motion is transmitted to the generator by a special type of belt which is not affected by the weather or dirt and which has a long life. The generator pulley has a wide flange for securely holding the belt in place. The belt is held taut by a compressed spring, the tension of which can be quickly adjusted without the use of tools, and will not change in spite of vibration. The belt

drive has been selected by the engineers of this company after ten years' experience with systems of train lighting.

The pole-changer used in this system is of marked simplicity. To the end of the generator shaft is attached a disc in which a T-shaped latch slides, the head of the T being considerably heavier than the lower part. As the armature revolves at slow speeds, the weight of the latch causes it to slide down in the groove, and when in this position the lower part projects beyond the disc,

and engaging in a suitable slot, throws the switch so as to make the proper connections between the generator and the battery. At about four miles per hour centrifugal force, acting upon the heavy head of the latch, throws it out of operation, so that the pole-changer is in action but a very short time at each start. This

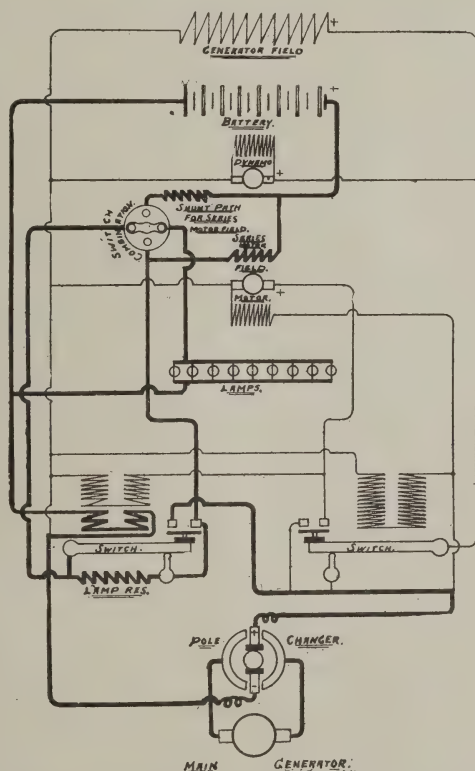

Wiring Diagram of the Moskowitz Electric Train Lighting System.

will prevent excessive wear and tear, and as the latch and other rubbing parts are hardened, the life should be long. The pole-changer switch is very simple and compact, and the whole arrangement is inclosed in a small cylindrical case attached to the frame of the generator.

Any type of battery can be used for this system. The voltage adopted is 32, requiring 16 cells. This low voltage is, of course, entirely safe, and permits the use of incandescent lamps having short, thick filaments which are not easily affected by vibration of the car. These lamps can be placed where most effective, giving a better illumination than central lights where the same amount of light is used, or giving an equally satisfactory illumination for a less total quantity of light.

The all-essential part in any train lighting system is the automatic regulator, and the regulator developed for this system has apparently reached a high stage of development. In it all ratchets, pawls and relays are done away with, the operation of the machine being entirely electrical. The main generator is excited by a small motor-generator. The generator part of this exciter is a small shunt-wound dynamo. The motor is compound wound. The two armatures are carried on the same shaft, the latter running in self-aligning oilless bearings. The two fields are formed in one casting, but are magnetically independent. The operation is as follows: When the speed of the main generator changes, the change in voltage arising from this alters the current through the series field of the regulator motor and thus changes the speed of the latter, and thereby the voltage of the exciting generator. This, of course, changes correspondingly the excitation of the main generator, bringing the voltage of the latter back to nor-

mal. The regulation secured in this way is good, as the pressure is held within one volt independent of the speed of the car and of the number of lamps in use. The regulator is very compact and is installed in the lower part of the case shown in the illustration.

The two magnetic switches shown in this illustration are the only automatic switches, excepting the pole-changer, of the whole system. The one on the right controls the exciter set, as will be described presently. The other connects the generator to the car circuit.

Referring now to the wiring diagram, the switches are shown in the position they occupy when the car is started. As the car comes up to speed, the pole-changer, which has properly connected the generator to the car circuit, is withdrawn from action. Tracing out the wiring circuits, it will be seen that the regulator control switch is connected across the generator terminals, as is also the exciting dynamo and the main generator field. As the car picks up speed, the main generator excites itself and also drives the exciting dynamo as a shunt motor. At about ten miles per hour the voltage of the main generator rises to about 25, which sends sufficient current through the coils of the electromagnet operating the regulator switch, shown on the right, to attract its armature. This closes the circuit through the exciting motor armature, and opens the main generator field circuit, leaving the latter connected across the exciter terminals. As the field of the exciting motor was already connected to the main circuit, this begins to run as a motor, driving the exciting dynamo as a generator, and thus separately exciting the fields in the main generator. As the speed of the car increases, the voltage of the main generator increases until

at about fifteen miles per hour it reaches 35. This pressure sends sufficient current through the shunt coil of the automatic generator switch, shown on the left, to attract its armature, and thus connect the main generator to the car circuit, supplying the lamps and charging the battery. The action of this switch also cuts in the lamp resistance, this being necessary to enable the generator to charge the battery and run the lamps at the same time. As the car slows down, in making a stop, the action of the regulator is reversed. As the voltage falls off, the automatic generator switch drops its armature, disconnecting the generator from the circuit and short-circuiting the lamp resistance so that the lamps are connected directly across the battery. To ensure the operation of this switch in this way, a series winding is placed on the electro-magnet, so that if the voltage of the generator falls sufficiently to allow the battery to send a current backward through it, this current will demagnetize the magnet and cause the armature to drop and open the switch.

Occasionally it may be desirable to charge the batteries at a greater rate than would take place under the conditions just described. For this purpose, a combination switch is provided, as shown on the diagram, which, when in one position, completes the circuits as just described, but when turned through 90 degrees, cuts out the lamp circuit and throws a shunt resistance in parallel

with the series field of the motor. This increases the speed of the latter, raises the voltage of the main generator, and charges the battery at a greater rate.

The automatic switches have been carefully designed, and operate without sparking. Although the main generator field is at one instant disconnected from the exciter, there is no interruption of the field current and consequently no sparking. The regulator has been reduced to an exceedingly simple group of mechanisms, there being but two switches and the small motor-generator exciting set. In operation it seems to more than justify the confidence of its inventors, as it acts quickly and surely and there seems to be nothing to get out of order.

From this description it will be seen that the Moskowitz system has been worked out with the idea of simplifying as far as possible all mechanisms and appliances. It is not the result of a few months, or even of a year or two of work, but has been developed by engineers who have been engaged on the problem of railway train lighting for the past ten years.

In addition to the advantages of better light and less heat, electric lighting has others. There is no objectionable odor, and when desirable, electric fans can be installed, adding greatly to the comfort of the passengers, and, above all, there is the absence of danger from fire in case of accidents.





With Our Foreign Consuls



The Simplon Railway—Consul Richmond Pearson, of Genoa, recently made a visit to the Simplon, in order to ascertain the character and progress of this stupendous undertaking, whose success or failure means so much for the future of Genoa. He states that his examination convinced him that the reports of serious obstacles, encountered in the south side of the tunnel, interfering with the progress of the work, and which would necessitate a change in the location of the line, were without foundation.

He further states that the work is progressing rapidly in the tunnel on both sides of the Alps; about 4,000 workmen are employed in the tunnel, and not less than 6,000 on the Italian section of the road between Isella, at the mouth of the tunnel, and Arona, the present terminus of the railway running north from Milan. It is now practically certain that the road will be completed within the estimated time—that is to say, by July 1, 1905—as nearly two-thirds of the tunnel was finished on July 1, 1902, and the worst obstacles have already been met and mastered. The greatest of the impediments was the ever increasing heat in the tunnel, caused by the growing volume of water, which, although it starts at the summit of the mountain, 6,000 feet above the line of railway, after percolating through beds of limestone, becomes almost boiling hot and flows into the tunnel at a temperature of from 112 to 140 degrees Fahrenheit, rendering not only

work, but life, impossible, without resort to artificial means of refrigeration. The engineer, by turning cold air on hot air and cold water on hot water, has reduced the temperature in the tunnel from 140 to 70 degrees Fahrenheit.

The volume of water flowing out of the south end of the tunnel is over 15,000 gallons per minute, and furnishes motive power sufficient not only to work the refrigerating apparatus, but to compress the air by which the drills are operated.

This tunnel, when completed, will be the largest in the world—to wit, 14 miles long, or twice the length of the Mont Cenis and 5 miles longer than the St. Gotthard. The cost of the tunnel alone will be \$13,510,000, an average of nearly \$1,000,000 per mile.

Railway Automobiles in Europe.—

United States Consul Marshal Halstead, of Birmingham, England, has sent the following to the Department of State:

On June 18 next, at 8.50 a. m., there will start from the Lyons station, in Paris, a train composed of three "automobile" carriages—that is to say, carriages that are both autonomous and motor cars—which will enter the Dijon station at noon. The 195 miles between Paris and Dijon will thus have been covered in three hours and ten minutes, or at a normal speed of 62 miles per hour; and the same speed may be maintained between Dijon and Lyons, Lyons and Marseilles, Marseilles and Nice, and Cal-

ais and Paris uninterruptedly, so that the distance between Calais and Nice can be covered in fourteen hours.

As its name indicates, the automobile supersedes the locomotive—that is, it dispenses in every train, short or long, slow or fast, with a weight of 110 tons. It saves the considerable cost of locomotives. It abolishes smoke, steam, noise, vibration, the jolt incidental to stopping and starting, and the necessity of stopping to take up water. It also abolishes all the men in charge of a locomotive except the engine driver. The new carriage is 56 feet long—that is to say, the length of the present corridor carriage. Of these 56 feet, a space of 8.5 feet in front is occupied by the traction apparatus, while the remaining 47.5 feet will comfortably accommodate 40 passengers and the 2,645 pounds of luggage allowed them. The cost of the automobile is the same as that of the first class corridor carriage, while the weight, including the traction apparatus, is also the same. Thus the abolition of the locomotive is an accomplished fact, and the rails which now have to bear the weight of the locomotive and tender as well as of the carriages are relieved therefrom.

By means of the slightest possible quantity of petroleum the smallest possible quantity of water can be converted into the greatest propelling power of steam which can be produced. The extremely powerful vapor thus obtained acts directly on the wheels of the automobile. Of course the petroleum is consumed, but the water, first transformed into vapor, condenses afresh, reverts to its original condition, and is then more easily transformed into steam; because it retains its heat. Thus, though the petroleum has disappeared, the water remains, which in temperate climates is of no inconvenience and in dry countries is of priceless value. Consequent-

ly, in front of every automobile is an apparatus producing with 1.05 quarts per 0.62 mile the steam power requisite for propelling the carriage with its 40 passengers and 2,645 pounds of luggage at a normal and almost minimum speed of 62 miles an hour, and that, too, without interruption, noise, or jerk. In order to overcome the air resistance which such a speed entails, the automobile in front and behind is so shaped as to cut the air, which thus becomes an auxiliary rather than an obstacle. As each automobile has its own apparatus, the carriages, of course, might go singly as easily as when coupled together. I may add that the weight of the apparatus, apart from the petroleum and water carried, is trivial. As to the latter, to go from Paris to Nice, 290.5 or 317 gallons of petroleum and 1,056 or 1,321 gallons of water will be required. This will allow of the whole journey being made without a stop; only care must be taken to guard against overheating.

The Northeastern Railway of England is building at its York works two auto cars to run on its railway, each of which will carry a complete apparatus for generating its own motive power. At one end of the car there will be a Napier petrol engine of 85-brake horse power, with 4 cylinders. This engine will drive a dynamo, generating electricity for 2 motors, which will apply the power to the wheels of the "bogie" underneath the engine compartment. Two of these four-wheeled "bogies," of practically the normal railway carriage type, will carry the framework of the car, but the body will be much lighter than that of an ordinary carriage, approaching closely to the tram type. In fact, the vehicle will be a tram saloon, with an engine compartment at one end and a conductor's compartment at the other. Seating accommodation will be provided in each

car for 52 passengers; and, as storage is provided for 30 gallons of petrol, it is anticipated that the automobile will be able to work five hours at a stretch without replenishing. It is calculated that by this system a speed of 30 miles an hour can be got up in as many seconds, which is a very much quicker acceleration than is possible with an ordinary train. It is not proposed to use these auto cars at first for the longer distance traffic of the Northeastern Railway, but to employ them rather for accelerating the service on those sections of the system where an ordinary train can only make a slow rate of speed, owing to the number of stopping places.

Producing Zinc by Electricity.—Consul R. S. S. Bergh sends from Gothenburg, Sweden, the following:

Experts in metallurgy have for some time discussed the report that Dr. De Laval, after extensive experiments, has been able to produce zinc from zinc ore by electricity at the factory Onan, belonging to Trollhattans Elektriska Aktiebolag, Trollhattan. It is reported that the manufacture of carbide at Onan has been discontinued and the production of zinc by Dr. De Laval's method adopted. An expert states:

"Dr. De Laval has for several years worked on the problem of producing zinc by electricity from lead-sulphur-zinc ores. He was probably led to this by his experiments in trying to separate iron from ores by electricity. An examining board has reported favorably on the method, and the result has been the organization of a company to exploit the invention and the ore deposits at Saxberget, near Ludvika. The minimum capital—\$26,800—has already been paid, and the company will start operations as soon as circumstances will allow."

German Professorship of Railroads.—Consul General Richard Guenther reports from Frankfort, Germany:

A regular professorship of railroading is to be created at the Technical High School of Berlin. Since 1901 a course of six lectures on railroading has been delivered at this school; but as this limited course was not sufficient for the important branch (for which a programme of instruction had been agreed upon in conjunction with the management of the State railroads), it is now proposed to establish a full professorship. Much more attention has recently been paid in the school to the construction of locomotives and to signalling.

Carborundum as a Furnace Lining.—A valuable use—which is both new and interesting—has been discovered for carborundum. It has been found that a thin layer of it, when applied to the material of which furnaces are usually constructed, acts as a protection against heat and renders it almost equally refractory. Finely powdered carborundum is made up into a paste with sodium silicate or some similar binding substance, and is then applied, by means of a brush, to the bricks of which the furnace is to be constructed, or the bricks are immersed in the compound. If the furnace has already been erected its exposed surfaces can be painted, giving them one or more coats, as may be desired. A layer two millimeters thick, it is claimed, will protect the bricks from attacks of the highest temperature produced by combustion methods in ordinary work, bricks treated in the above manner, upon being examined after the furnace has been pulled down, showing absolutely no injury. The layer of carborundum does not chip off, and is hard enough to resist mechanical injury.—*Exchange.*

The Diesel Engine

By ALBERT HADLEY

A NEW and important epoch in the manufacture of internal combustion engines was marked by the advent of the Diesel engine. In the best steam plants the total amount of the heat of the fuel converted into steam equals only about 10 per cent., whereas the Diesel engine, it is claimed, converts about 25 to 30 per cent. into work, in the smaller as well as larger sizes. This difference is a remarkable one and the, particularly at present, great disproportion in the prices of coal and crude oil, makes this type of engine one well worthy of the investigation of power users.

Unlike the ordinary gas or internal combustion engines of other types, the Diesel engine does not operate by an explosion, but depends for its action upon the fact that air under compression assumes a high temperature, and that if oil is introduced into it at a certain temperature, or above it, it must ignite and consequently burn. In the Diesel process the air heated by compression reaches a temperature of about 800 degrees Fahrenheit, at which temperature crude oil will burn completely without residue, in the presence of a sufficient amount of air. The only mixture of combustible elements in the cylinder oc-

curs when combustion is intended to begin. Fuel is injected gradually into the highly heated air by means of an atomizer, being delivered in the form of a mist, not a vapor; each drop of spray burning immediately and quietly, so that no explosion takes place, the period of injection and the quantity injected being delicately regulated by the governor in accordance with the demand for power. This regulation is effected within the fourth stroke cyclic period of the thermodynamic action, and every such period has its working stroke. While in the steam engine steam has received heat from the fuel at the boiler, in the Diesel engine air receives heat direct from the combustion of oil fuel mixed with the air in the working cylinder.

The engine operates on the Otto cycle, or four-stroke principle, the first stroke filling the cylinder with air at atmospheric density. The second stroke compresses the air to about 35 atmospheres; it being at the point of highest compression practically in an incandescent condition. At the reversing point in the stroke of the piston the oil is introduced in the manner described above, igniting immediately and burning slowly through a limited portion of the stroke. The third or working stroke is

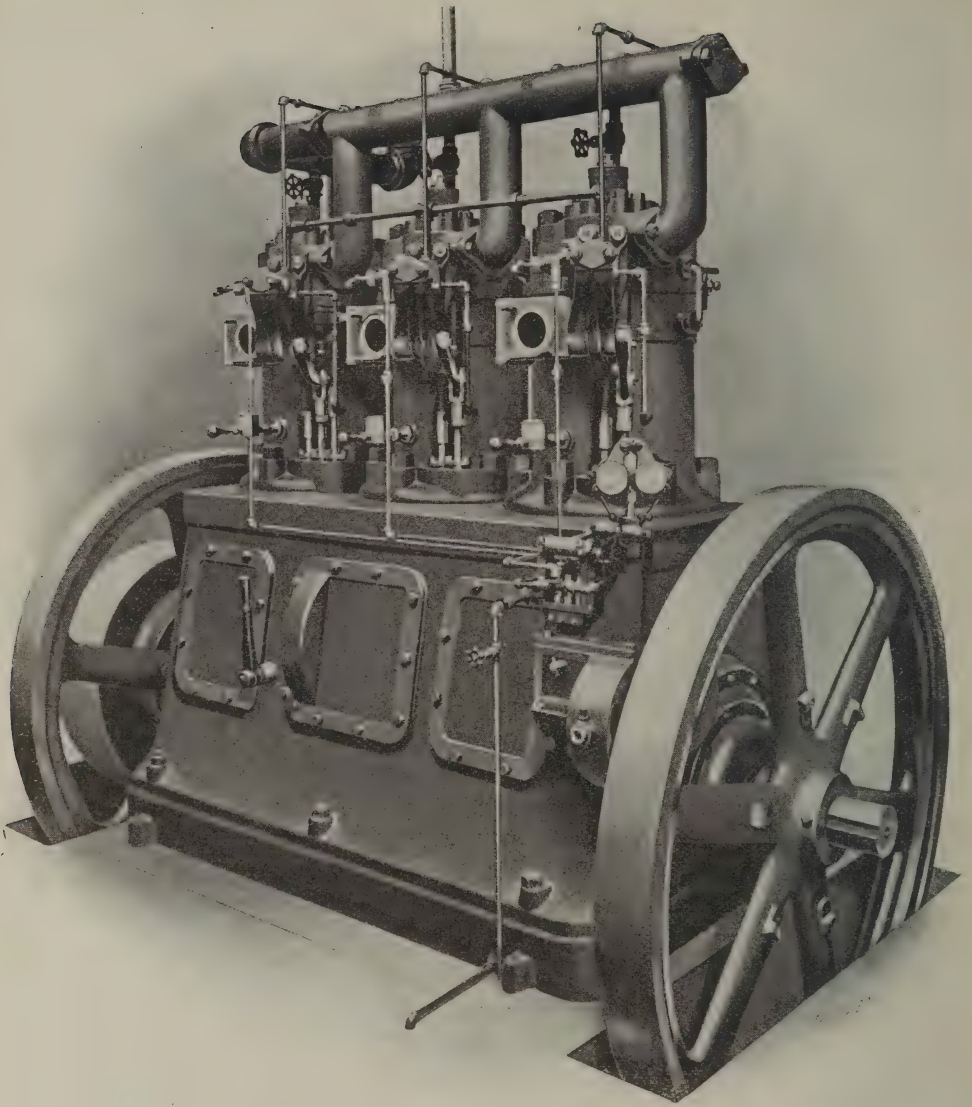

Triple-Cylinder Diesel Engine.

completed by the expansion of the air and gases, the fourth stroke ejecting the gaseous products of combustion and clearing the cylinder for a repetition of the cycle.

The following conditions must be complied with in order to make the nearest possible approach to the perfect Car-

not cycle: the highest temperature of combustion must be produced, not by and during combustion of the fuel, but before and independently of it—wholly by mechanical compression of pure air alone. Then a small quantity of the finely divided combustible must be introduced into a large excess of highly

compressed and heated air in such a manner that only a slight increase of temperature is caused by the ignition of this charge, while the heat generated by the general combustion is immediately converted into work by the expansion of the air and products of combustion.

It is claimed that all these requirements are fully met with in the Diesel engine. The consumption of fuel, regardless of the size of the unit, will not exceed 0.5 to 0.6 pounds per brake horse power when the engine is operating within its economical range. This range is so large a part that in adapting a Diesel engine to a widely varying load, the element of efficiency at different loads may be practically put aside. In determining upon the size of an engine to meet a certain set of requirements, the advantage of this will be appreciated by engineers who have wrestled with the problem in choosing a steam engine.

The engine is started with compressed air from a storage tank, and ignition is secured during the first revolution. The compressed air supply is cut off automatically and the permanent air supply—which injects the oil—is thrown into operation—also automatically—when the engine comes up to speed. Under ordinary conditions the exhaust is clean and odorless and the exhaust pressure is much lower than is usual in engines of the internal combustion type. By varying the amount of oil introduced at each working stroke, under control of a governor, regulation is effected. Very

close governing is obtained, due to the response of the engine speed to the governor action being far quicker than in a steam engine. As any number of engine units may be controlled from one governor, practically absolute synchronism of running may be obtained, this being a consideration of great importance in up-to-date electrical engineering practice.

Among the remarkable features of the Diesel engine are the ease, promptness and quietness with which it is started up. No preparation whatever is required, the engine being taken exactly as it may have been standing idle for one or more hours, days or even weeks. The pulling of the crank to the top dead-point; the pulling over of a small hand lever, and the opening of a small screw-down air valve are all the manipulations required. After about four or six revolutions, the starting lever is again thrown back and the engine thereafter looks after itself. In the larger sizes this starting lever and cam are thrown automatically out of gear by the governor as soon as normal speed is reached; in the smaller sizes, however, hand gear is preferable, and it is always available in the larger sizes.

It seems as though this engine would be particularly adapted for long distance electric traction work, inasmuch as units of this character can be used as substations along any railway line under many conditions with greater economy than is possible with high tension current from a central station and transforming substations.



The Electrical Age

Incorporated April, 1902

CHARLES A. LIEB, - - - - PRESIDENT

New York, March, 1903

Volume XXX

No. 3

Published Monthly.

Subscription, \$1.00 per year. Single Copies, 10 Cents.
(\$2.00 Per Year to Foreign Countries.)

20 BROAD ST., NEW YORK. Telephone 1628 Cortlandt.

THE ELECTRICAL AGE (Incorporated)
Entered at New York Post Office as Second Class Matter.
Copyright, 1902, by THE ELECTRICAL AGE.

TO ADVERTISERS

Changes for advertisements and new advertisements **must** be in this office by the **20th** of the month to be included in the issue in the month following. The advertising pages carry printed matter measuring five and a half by eight inches. Cuts intended for use on these pages should be made to accord with these measurements.

Correspondence and semi-technical articles, with suitable photographs for reproduction, or cuts, are invited. Accepted matter will be promptly paid for. We cannot be responsible for any unsolicited manuscripts, but when stamps are enclosed all unavailable matter will be returned. Postage must always be fully prepaid. Cuts to be available for illustrating articles must conform to the column or page measurements. The columns are $2\frac{1}{2}$ inches wide. Cuts for single column use should not exceed that width. Cuts to go across the page should not be more than five inches wide, and full page cuts may not exceed $4\frac{1}{2}$ x 8 inches.

THE much dreaded time, when the business man, seeking a short rest from the worries and cares of an active business career, hies himself aboard an ocean greyhound under the delusion that by doing so he will be able to escape the click of the ticker and the raucous voice of the newsboy, only to find that he has stepped from the frying pan into the fire, has now arrived. With it has come the opportunity for our fellow workers on the daily press to compare the erstwhile innocuous desuetude, which reigned so long aboard the fleet-winged flyers of the transatlantic fleet, with the strenuous era which has been begun by the publication of the first wireless newspaper aboard the Etruria.

The financier, who ashore furnishes "copy" for column after column of scathing comment, will now, by stepping aboard a liner, find himself the object of the tender solicitude of the very correspondent who once railed at him. He may even himself publicly bewail his bitter fate in no longer being able to find even the short repose which the flight across the "pond" once brought him, but we venture to believe that he will be among the first to clamor for the mid-ocean daily and to heap scorn and derision upon the editor when its appearance has been delayed even for five minutes.

The first actual newspaper containing bona fide telegraphic news communicated from land to a vessel at sea, was recently brought to New York by the Etruria. This curious looking little printed sheet was issued to the steamer's passengers in latitude 51, longitude 9 degrees, 20 minutes, on the afternoon of February 7. A few hours before she made her way into Queenstown her Marconi receiver gave forth a calling spark. The operator at once began taking the incoming messages, and when he had finished he had received in succinct form the news of the world. Signor Marconi, who was at his side, was greatly elated at the success of the enterprise, which an hour later resulted in the appearance of a newspaper containing all of the world's important news.

A favorable opening for the automobile seems to present itself in Natal. On account of the prevailing climatic conditions there horses suffer extremely, and during long periods of the year are rendered incapable of work, and as the existing tramways seem to be quite unable to cope with the passenger and freight traffic business, it would repay manufacturers of automobiles to look into this.



New Inventions

For which Patents have been Granted



719,018. AUTOMATIC ELECTRIC CIRCUIT CONTROLLER. Harry W. Leonard, New York, N. Y. Filed May 7, 1901. Serial No. 59,122. (No model.)
In a regulating rheostat, the combination of a hand-operated, current-carrying arm, a hammer arm normally restrained against a

means for controlling the action of said valve operating periodically and independently of any variations of pressure in the source of compressed air.

719,095. LINE-TAPPING DEVICE FOR TELEGRAPH OR TELEPHONE CIRCUITS. Christian Dietz, Munich, Germany. Filed August 2, 1902. Serial No. 118,119. (No model.)

The combination, with a rigid conductor, and a flexible conductor, of means supported by the rigid conductor and arranged to connect the rigid conductor and the flexible conductor, respectively, to the corresponding line wires.

720,152. COMMUTATOR METER. John F. Kelly, Pittsfield, Mass. Filed October 19, 1901. Serial No. 79,227. (No model.)

In a meter, the combination of a field-energizing coil in series with the mains carrying the current to be measured, an armature having a plurality of armature coils with separate terminals and located in a shunt to said mains, a commutator having less than six segments, the segments being at

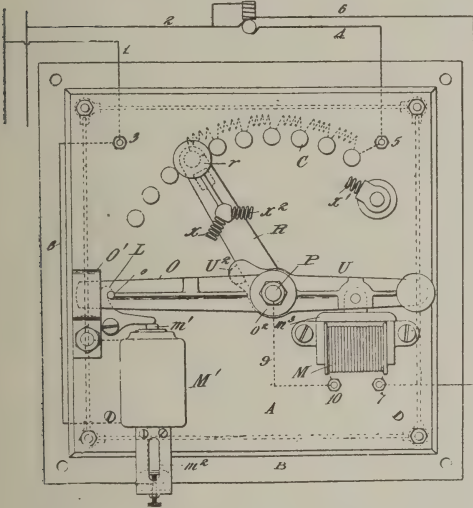

719,018. Automatic Electric Circuit Controller.

force constantly tending to move the hammer arm, means for releasing the hammer arm when the electro-motive force of the circuit passes a certain limit, and automatic means for opening the circuit when the current in the circuit passes a certain limit.

719,020. RAILWAY ELECTRIC MOTOR-COOLING SYSTEM. Cyprien O. Mailloux and William C. Gotshall, New York, N. Y. Filed October 6, 1902. Serial No. 126,129. (No model.)

The combination with an electric railway motor and a source of compressed air carried by a car propelled thereby, of a valve adapted to release and discharge the air from said source into or upon the motor to keep the temperature of the same down, and

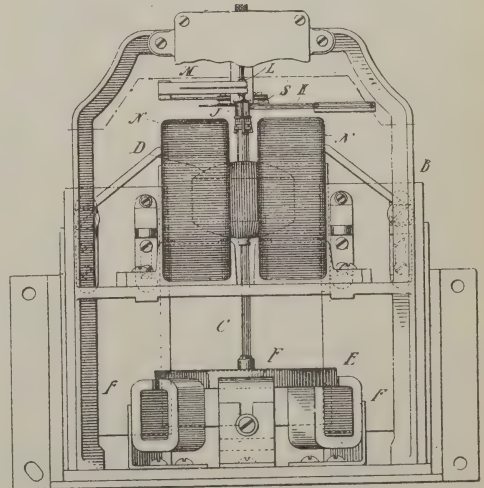

720,152. Commutator Meter.

the angles of a polygon and having their contact surfaces separated from each other by spaces several times as great as the width of each segment, each segment being connected to but one armature coil terminal and a brush wiping over the angles formed by said segments.

720,004. TELEGRAPHY. Patrick B. Delaney, South Orange, N. J. Filed March 18, 1901. Serial No. 51,618. (No model.)

In a telegraph system in which each signal is composed of two impulses of opposite polarity sent into a circuit at a transmitting station, the method of transmission and recording, which consists in adjusting the capacity or consequent retardation effect of the circuit so that the formation of a record character will be continued after its primary impulse is sent into the circuit, sending the primary impulse of a signal into the circuit to initiate the production of a record thereof, disconnecting the generator from the circuit and permitting the "capacity" effects of the circuit to continue the production of said character, and terminating the formation of the character by transmitting the secondary impulse of opposite polarity.

719,418. ELECTRIC ACCUMULATOR PLATE. Auguste Bainville, Nanterre, France. Filed July 14, 1902. Serial No. 115,462. (No model.)

An electric accumulator consisting of a number of rods separated from each other

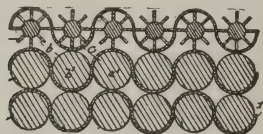

719,418. Electric Accumulator Plate.

by a removable corrugated sheet of perforated insulating material arranged in such manner as to cover the face of one rod and the back of the next.

719,549. LIQUID RESISTANCE SWITCH FOR ELECTRICAL PURPOSES. John H. Wooliscroft, Sandycroft, England. Filed October 3, 1902. Serial No. 125,798. (No model.)

In liquid resistance switches, an inclosed drum or case, a liquid resistance therein, internal and external blades in electrical connection carried by said drum but insulated therefrom, a short-circuiting plate in electrical connection with the drum and a collector adapted to make contact with the external blade and also with the short-circuiting plate, substantially as described.

718,661. STEAM TURBINE. Richard Schulz, Berlin, Germany. Filed April 2, 1901. Serial No. 56,986. (No model). In combination high and low-pressure tur-

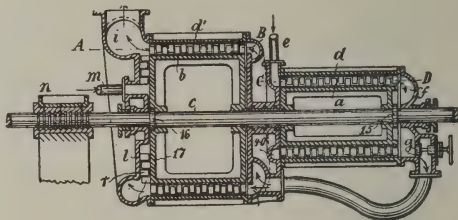

718,661. Steam Turbine.

bines connected in tandem, organized to exert axial pressure in opposite directions and a radial reversing turbine in the low-pressure casing, substantially as described.

719,325. ELECTRO-MECHANICAL GOVERNOR. Elisha Gray, Highland Park, Ill., assignor, by mesne assignment, to the Gray Telephone Company, Waterville, Me., and Boston, Mass., a corporation of Maine. Filed November 6, 1899. Serial No. 736,036. (No model.)

The combination of a valve, magnets for moving the valve in both directions, a centrifugal lever of the character specified, contact points limiting the movement of the lever electrically connected with the magnets, a battery, or other source of electric energy, connected with the magnets and with the centrifugal lever, as and for the purposes set forth.

719,355. ELECTRIC TELEGRAPHY. Alexander Muirhead, Shortlands, England. Filed August 11, 1902. Serial No. 119,247. (No model.)

The combination in a telegraphic relay of a receiving coil energized by message impulses, an index actuated by the coil, means applied directly to the index, independently of the coil to give directive force thereto and further means serving to turn a part of said first-named means to give directive force to the index, and thereby correct the "zero" thereof.

719,998. TELEPHONE SYSTEM. Edward E. Clement, Philadelphia, Pa. Filed June 4, 1901. Serial No. 63,052. (No model.)

In a signaling system, two stations and a connecting circuit between them; a responsive device at one station and a source of current at the other, a sensitive resistance device at the first station normally holding the responsive device out of operative connection with the circuit, and a source of energy at the second station to alter the condition of the resistance device to bring

the magnetic device into operative connection with the circuit, and to operate the same.

720,208. MECHANISM FOR REMOVING ICE AND SNOW FROM THE CONDUCTING OR THIRD RAIL OF ELECTRIC RAILWAYS. Frederick V. Winters, New York, N. Y., assignor of one-half to John Scott McWhirter, New York, N. Y. Filed August 5, 1902. Serial No. 118,436. (No model.)

A snow and ice cleaner for third rails, comprising horizontally arranged and pivotally supported arms, a crushing wheel journaled in the free ends of the horizontal arms, and a spring pressing device to hold the crushing wheel on the third rail.

719,551. ELECTRIC TIME ALARM SYSTEM. Edwin T. Ackerman, Chicago, Ill., assignor of one-half to Thomas A. Smyth, Chicago, Ill. Filed October 4, 1901. Serial No. 77,510. (No model.)

In an electric alarm system the combination of an electric alarm circuit, a clock mechanism having a moving member forming a part of said circuit, an alarm contact for said member forming a part of said circuit, an alarm included in said circuit, a switch included in said circuit, a cut-in contact with which said member connects, a switch circuit including said cut-in contact and member, a switch-actuating mechanism included in said switch circuit for opening and closing said alarm circuit, substantially as set forth.

719,465. ELECTRIC CLOCK. Vitalis Himmer and Vitalis Himmer, Jr., Bayonne, N. J.; said Vitalis Himmer, Jr., assignor to said Vitalis Himmer. Filed March 15, 1902. Serial No. 98,367. (No model.)

In an electric clock, the combination of a driving means, electrically operated mechanism for generating the power of said driving means, a pair of terminals in the electric circuit, a terminal-carrying lever carrying one of said terminals, a lever oscillated by the driving means, and a circuit-breaking lever separate from said terminal-carrying lever, and arranged to transmit the movement of said oscillated lever to said terminal-carrying lever to separate said terminals.

718,918. STEAM TURBINE. Lucien E. Crespin, Paris, France. Filed January 21, 1902. Serial No. 90,678. (No model.)

In a multiple-expansion steam turbine, the combination with a plurality of fixed tubular necks, in line with each other, all but the upper necks having ports in their walls, of flat, circular hollow heads, each communicating with the neck above it only, and having nozzles in its periphery, a rotatable shell concentric with said necks and heads, and having internal buckets registering with said

nozzles, and internal hollow ribs on said shell communicating with said buckets and fitting said necks, and provided with ports and annular grooves in line with the ports in said necks.

718,610. ELECTRIC CLOCK. Walter J. Dudley, Bangor, Me. Filed August 20, 1902. Serial No. 120,287. (No model.)

The combination with a time-measuring vibrator of an impelling device moved in one direction by said vibrator and in the other by a constantly acting force as that of a weight, an impulse arm acting directly on said impelling device against said constantly acting force, an electro-magnet controlled by said impulse arm, an armature for said electro-magnet and a locking catch for said impulse arm operated by said electro-magnet and said impelling device in turn, as set forth.

718,637. SECONDARY BATTERY. Isidor Kitsee, Philadelphia, Pa. Filed April 28, 1900. Serial No. 14,689. (No model.)

In an electric cell an electrode consisting of the conductor proper, said conductor formed so as to provide spaces for the active material in combination with an active material consisting of a series of individual and independent blocks, each block consisting of a conducting skeleton and active material contained in the spaces of said skeleton.

718,686. TELEPHONE SYSTEM. Frank B. Wood, New York, N. Y., assignor, by direct and mesne assignment, to Frank B. Wood, Jr., and Catherine Wood, New York, N. Y. Filed August 29, 1901. Serial No. 73,642. (No model.)

A telephone and calling system comprising a central office and stations, an independent line extending between central and each station, a common return wire whose circuit is normally open at each station, means for producing calls at central from said stations, telephone instruments at said stations for connection with said lines, telephone instruments at central, a branch wire for connecting said telephone instruments at central with said common wire, and means for connecting said instruments with either of the first-mentioned lines, substantially as described.

718,695. ELECTRIC CLAM DREDGE. Ephraïm Chaquette, New Rochelle, N. Y. Filed November 20, 1901. Serial No. 82,997. (No model.)

The above described electric clam dredge, which consists of a suitable float, a clam carried thereby and mechanism for raising and lowering the same vertically at the edge of said float, an electric motor located in said clam and devices substantially as described whereby said clam is automatically opened at the top of its ascent and closed when it reaches the bottom, substantially as described.

718,697. INDUCTION MOTOR. Cummings C. Chesney, Pittsfield, Mass. Filed July 30, 1902. Serial No. 117,723. (No model.)

In an armature for an induction motor, the combination of an armature core, separately formed conducting U-shaped pieces therein, and a conducting ring to which the ends of said U-shaped pieces are secured.

718,758. ELECTRICALLY OPERATED TYPE-WRITING MACHINE. John S. Harrison, Savannah, Ga., assignor, by direct and mesne assignments, to Prendergast Electric Typewriter Company, a corporation of Maine. Filed April 12, 1902. Serial No. 102,593. (No model.)

In a type-writing machine having a type wheel, keys, mechanism controlled by the depression of the keys for moving said wheel to printing position, hammer operating mechanism, and controlling mechanism for releasing the carriage and hammer operating

mechanisms, the combination of an electro-magnetic device, a link connection between said electro-magnetic device and the controlling mechanisms for moving the type wheel to printing position and for releasing the carriage and hammer operating mechanisms, and means for closing the circuit through said electro-magnetic device, as each key is depressed, whereby, as each key is depressed, the magnetic device is energized and the said controlling mechanism operated through said link connection, substantially as described.

719,005. TUNING DEVICE FOR WIRELESS TELEGRAPHY. William S. Hogg, U. S. Navy, assignor of one-half to the Greater New York Security Company, New York, N. Y., a corporation of New York. Filed March 4, 1902. Serial No. 96,675. (No model.)

A tuning device for electric circuits, having a combined variable self-induction and variable capacity.

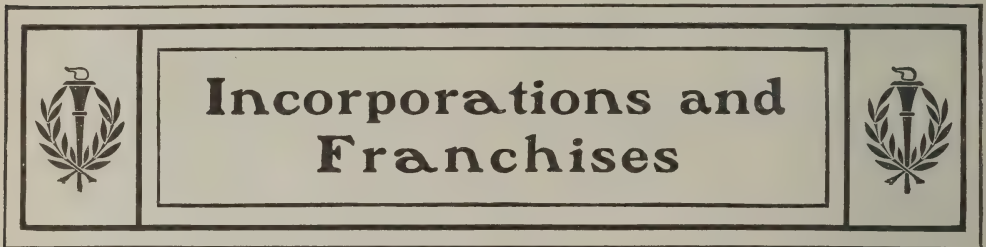

ALABAMA.

Birmingham—The Sheffield Company has been incorporated under the laws of New Jersey with a capitalization of \$525,000. The new company will acquire the waterworks of Sheffield, the electric light franchise, and franchises for trolley lines to Tuscumbia and Florence. Colonel A. P. Andrews, of the Southern Railway, and J. C. Mayben are interested, as are also George Parsons, of New York; his brother, Charles Parsons, and Messrs. Goodby, Strong & Mortimer.

CALIFORNIA.

San Luis Obispo—The San Luis Obispo Light, Heat & Power Company has re-incorporated as the Pacific Coast Light, Heat & Power Company; capital stock, \$500,000; paid up, \$150,000. The reason for the change is to enable the company to extend its business to neighboring counties. William V. Miller, of Bakersfield, and E. S. Hoyt, of this city, are the principal stockholders.

DISTRICT OF COLUMBIA.

Washington—The Potomac River Power Company is reported organized, with J. F.

McLaughlin, of Toronto, Ont., as president, to erect buildings necessary for the establishment of a large water power plant near Washington.

FLORIDA.

Jacksonville—The Jacksonville Traction Company has been chartered with \$400,000 capital. The incorporators are G. W. Shook and P. A. Dignan, of Jacksonville, and others.

ILLINOIS.

Chicago—The Chicago Street Lighting Company has been incorporated with a capital stock of \$25,000 by A. J. Hirsch, F. W. Bigelow and A. J. C. Timm.

INDIANA.

New Harmony—The Mt. Vernon, New Harmony & Northeastern Traction Company is to be incorporated. Harry Kurtz is interested.

Indianapolis—The Indianapolis & Cincinnati Traction Company, with a capital of \$1,500,000, has been incorporated by Charles L. Henry, W. L. Taylor, T. F. Rose, Ephraim Marsh, William M. Fransee, A. M.

Johnson and James F. Fesler. The line in Indiana will run from Indianapolis to New Palestine, Morristown, Rushville, Connersville and Brookville.

KENTUCKY.

Louisville—The Louisville & Interurban Railroad Company has been organized with \$500,000 capital stock by the officials of the Louisville Railway Company. It is the intention to build a road from Louisville through the counties of Jefferson, Oldham, Shelby, Spencer, Nelson and Bullitt.

MARYLAND.

Cumberland—The Cumberland Narrows Electric Railway Company has been incorporated with a capital of \$20,000. Judge R. H. Koch, of Pottsville, Pa., is one of the incorporators.

MAINE.

Augusta—The Columbus Electric Company has been organized at Portland with a capital stock of \$1,250,000. The promoters are Gardner Rogers, Brookline; Henry R. Hayes, Dedham; John W. Hallowell, Medford; Ardon W. Coombs, Charles H. Tolman, Portland. Ardon W. Coombs is president, and Gardner Rogers is treasurer.

Fryeburg—The Fryeburg Electric Light Company has been incorporated with a capital of \$10,000. Henry B. Cotton, Conway, N. H., and A. R. Jenness, of Fryeburg, are among the incorporators.

MICHIGAN.

Detroit—The Lapeer Light & Power Company has been formed with \$75,000 capital stock, and has absorbed the lighting plants at Lapeer, Imlay City, Millville and Higley. J. Schlegel is president, and Henry Schlegel, secretary-treasurer of the company.

Grand Rapids—J. H. Mitchell, Sol. P. Kinson and W. H. Settle are promoters of a new electric light and power company that will operate here. They have petitioned the council for a franchise to furnish electricity for light and power, steam and hot water for heating, and cold water for refrigerating purposes.

Kalamazoo—The Otsego Power Company, Limited, capital \$200,000, has filed articles of association. The officers are Glenn L. Smith, Jackson, chairman; Edward B. Marinane, Grass Lake, secretary; and Jacob H. Boots, Jackson, treasurer.

Lansing—Articles were filed to-day by the Michigan Shore & Eastern Railway with \$1,000,000 capital. The line in Michigan runs from Bertrand Township, Berrien County, on the Indiana State line, to Kalamazoo, and it is the purpose of the new company to absorb

the Benton Harbor, Coloma & Paw Paw Lake Tram Railway and the South Haven & Eastern.

MISSOURI.

St. Louis—The Ewing-Meikle Electric Company has filed letter of incorporation with a capital stock of \$50,000, paid up. The shareholders are Nathaniel Ewing, William Brown, Milton Mill and William Meikle.

NEW YORK.

Albany—The West 86th Street Railway Company of New York City has been incorporated to operate an electric street surface railroad, 2,000 feet long, on West 86th street, from Eighth avenue to Amsterdam avenue. The capital is \$10,000, and the directors are Charles E. Warren and D. B. Hasbrouck, of Brooklyn; Oren Root, Jr., M. G. Starrett, R. W. Meade, R. Martin and Denis O'Brien, of New York City; De Clifford Moorehead, of Jamaica, and F. D. Edmunds, of Flushing.

NEBRASKA

Omaha—The Omaha, Decatur & Northern Railway Company, with a capital of \$1,000,000, has filed articles of incorporation with the Secretary of State. The company intends to build an electric railway through the counties of Douglas, Washington, Burt, Thurston and Dakota. The headquarters will be in Omaha. The incorporators are C. E. Burlow, A. M. Anderson, E. H. Martin, H. D. Bryan, P. B. Gordon, W. R. Lewis, F. W. Bennett, F. E. McNutt, H. H. Bone and G. H. Pusse.

NORTH CAROLINA.

Hickory—The Thornton Electric Light Company, of Hickory, has been chartered with a capital stock of \$8,000.

High Point—The High Point Electric Power Company has been incorporated with a capital of \$20,000 by A. N. Richardson and W. S. Thomas.

ONTARIO.

Hamilton—The Hamilton Cataract, Power, Light & Traction Company has been incorporated with a capital of \$5,000,000 by J. M. Gibson and J. R. Moodie, of Hamilton, and J. A. Kammerer, of Toronto.

OHIO.

Bowling Green—The Port Clinton Peninsular Electric Railroad Company has been incorporated by Charles York, of Port Clinton; W. M. Tuller, Dr. F. W. Rogers, R. N. Beatty and Charles M. Draper, of Bowling Green. It is proposed to build a line from Port Clinton to Marblehead and Lakeside by way of Oak Harbor and Elmore.

Dayton—The Covington, Bradford & Versailles Traction Company has been incorpor-

ated by Dennis Dwyer, Albert Emanuel, B. M. Hopkins, E. C. Spring and T. H. Robinson.

Springfield—The Citizens' Light, Heat & Power Company has been granted a franchise in Springfield.

Wilmington—The United Water & Light Company has been incorporated under New Jersey laws. It has \$200,000 capital stock and will erect a plant here.

Cleveland—The incorporation of the Mansfield, Crestline & Galion Railway, with a nominal capital of \$10,000, was the preliminary step of the merging of the new line between Mansfield, Crestline and Galion with the Ohio Central Traction Company. Nominally it has been a part of that line since it was completed some weeks ago. The new company will continue the name of the Ohio Central Traction Company and will have a capital stock of \$700,000. When the Wellington-Mansfield line is completed, the whole will be absorbed by the Cleveland & Southwestern Traction Company. All the roads mentioned are Pomeroy-Mandelbaum properties.

PENNSYLVANIA.

Philadelphia—Articles of incorporation of the Baltimore & Belair Electric Railway have been filed with the Secretary of State. The capital stock is \$500,000. The route will be either upon the Baltimore & Hartford or Baltimore & Jerusalem turnpike.

TEXAS.

Brownwood—The Bayson Light & Power Company has been incorporated with a capital of \$30,000.

Pilot Point—A company has been organized here to construct an electric light plant and ice factory. J. E. Light, president; A. W. Walker, secretary.

WASHINGTON.

Aberdeen—The Gray's Harbor Power & Light Company has been organized, with a capital of \$250,000, by John L. Wilson and E. C. Finch, of Aberdeen. Power for running the plant will be obtained from Little North River Falls.

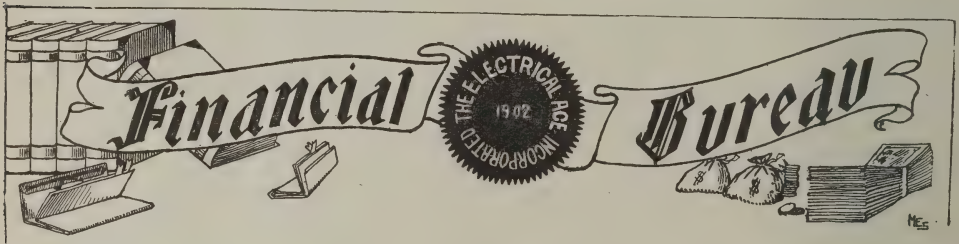

Street railway companies, electric lighting companies and gas companies which desire their reports to appear in the Financial Bureau of THE ELECTRICAL AGE are requested to forward the information so that it may reach us by the 20th of each month. Monthly reports are requested showing gross receipts and when possible operating expenses. Companies are also requested to furnish the highest and lowest prices for which their stock has sold in the market for the previous month.

Street Railway and Other Statements

Companies.	Date.	Gross Earnings.		Net Earnings.	
		1902.	1901.	1902.	1901.
BROOKLYN HEIGHTS—					
For qtr. ending Dec. 31.....		2,960,548.00	2,791,145.00	1,137,765.00	835,794.00
BROOKLYN, QUEENS CO. & SUB.—					
For qtr. ending Dec. 31.....		251,253.00	209,951.00	109,362.00	100,321.00
BROOKLYN R. T. SYSTEM (All Cos.)—					
Six months.....		6,836,369.00	6,513,239.00	3,051,194.00	2,429,510.00
CONEY ISLAND & GRAVESEND—					
For qtr. ending Dec. 31.....		1,572.00	1,089.00	57.00	56.00
INT'N'L TRACTION CO. SYSTEM..Dec.		\$309,871.35	\$270,650.97	\$139,914.03	\$95,827.06
For qtr. ending Dec. 31.....		904,171.31	732,376.73	411,180.69	354,332.33
ST. LOUIS TRANSIT CO.....Jan.		527,870.05	460,685.06		

TOLEDO RAILWAYS & LIGHT CO.—Jan.	Gross Earnings.		Net Earnings.	
	1903.	1902	1903.	1902.
	125,493.00	113,177.00	63,097.00	55,410.00

Stated Reports of Companies

Rochester Railway Company.

The Rochester Railway Company reports for the quarter ended December 31:

	1902.	1901.	Changes.
Gross earnings	\$308,999	\$261,880	Inc. \$47,119
Operating expenses	164,639	141,487	Inc. 23,152
Net earnings	\$144,360	\$120,393	Inc. \$23,967
Other income	312	3,559	Inc. 3,247
Total income	\$144,672	\$123,952	Inc. \$20,720
Fixed charges	84,679	79,120	Inc. 5,559
Surplus.....	\$59,993	\$44,832	Inc. \$15,161

The general balance sheet as of December 31 shows:

Assets—	Liabilities—
Cost of road, etc.....	Capital stock, common.....
Stocks and bonds.....	Preferred
Supplies on hand.....	Funded debt.....
Due by others than agents.....	Mortgage and paving assessments.....
Open accounts	Interest on debt due and accrued.....
Prepaid rentals and miscellaneous.....	Taxes due and accrued.....
	Damages accrued
	Due for supplies.....
	Special accounts.....
	Reconstruction reserve account...
	Profit and loss surplus.....
Total.....	Total.....

Annual Report of the Everett-Moore Roads.

The annual reports of the electric railway systems controlled by the Everett-Moore syndicate for the fiscal year ended December 31 are issued. The net earnings are as follows: Cleveland, Elyria & Western net, \$129,771, increased \$17,377; Cleveland, Painesville & Eastern net, \$83,518, increased \$5,649; Detroit United Railroad net, \$1,534,222, increased \$155,171; Detroit & Port Huron

Shore Line Railroad net, \$172,917, increased \$10,308; Eastern Ohio Traction Company net, \$81,673, increased \$24,590; Lake Shore Electric Railroad net, \$149,474, increased \$33,679; London Street Railroad (Ontario) net, \$61,456, increased \$4,167; Northern Ohio Traction Company net, \$334,251, increased \$68,085; Toledo Railways and Light Company net, \$732,312, increased \$57,635.

The condensed statement shows:

	1902.	1901.	Changes.
Gross earnings.....	\$7,424,149	\$6,445,102	Inc. \$979,047
Operating expenses and taxes....	4,144,558	3,541,171	Inc. 603,387
Net earnings.....	\$3,279,591	\$2,902,931	Inc. \$376,660

Coney Island & Brooklyn.

The Coney Island & Brooklyn Railroad Company reports operations for the quarter ended December 31:

	1902.	1901.	Changes.
Gross earnings	\$334,530	\$308,218	Inc. \$26,312
Operating expenses	244,310	204,544	Inc. 39,766
Net earnings	\$90,220	\$103,674	Dec. \$13,454
Other income	1,041	1,304	Dec. 263
Total income	\$91,261	\$104,978	Dec. \$13,717
Fixed charges	66,900	69,834	Dec. 2,934
Surplus.....	\$24,361	\$35,144	Dec. \$10,783

The general balance sheet as of December 31 shows:

Assets—	Liabilities—
Cost of road and equipment.....	Capital stock, common.....
\$3,437,629	\$2,000,000
Stocks and bonds.....	Funded debt
1,000,000	2,000,000
Other permanent investments.....	Loans and bills payable.....
60,843	97,610
Accrued interest.....	Interest due and accrued.....
93,500	43,500
Supplies on hand.....	Rentals due and accrued.....
56,239	196,210
Open accounts.....	Accrued taxes
45,373	76,948
Cash on hand.....	Due for wages.....
100,818	3,622
Prepaid insurance	Due for supplies.....
9,787	62,695
	Open accounts
	29,477
	Profit and loss surplus.....
	294,127
Total.....	Total.....
\$4,804,190	\$4,804,190

The South Buffalo Railway Company reports for the quarter ended December 31, 1902: Gross earnings, \$47,209; operating ex-

penses, \$28,889; other income, \$30,000; fixed charges, \$375; surplus, \$18,065.

The general balance sheet shows:

Assets—	Liabilities—
Cost of road, etc.....	Capital stock.....
\$737,908	\$500,000
Due by agents.....	Loans and bills payable.....
26,974	170,000
Due by others.....	Due for supplies.....
688	22,652
Open accounts	Due for wages.....
539	2,928
Cash on hand.....	Open accounts
11,708	35,802
	Profit and loss surplus.....
	46,435
Total.....	Total.....
\$777,818	\$777,818

The Brooklyn Heights Railroad Company reports its general balance sheet as of December 31, as follows:

Assets—	Liabilities—
Cost of road, etc.....	Capital stock
\$462,885	\$200,000
Stocks and bonds.....	Funded debt
50,000	250,000
Supplies on hand.....	Interest due and accrued.....
387,849	3,125
Open accounts	Rentals due and accrued.....
222,404	960,828
Cash on hand.....	Insurance fund
1,314,495	46,000
Prepaid insurance	Open accounts
35,387	488,435
Additions and betterments on leased lines	Taxes accrued
8,973,172	872,319
Accounts to be adjusted.....	B. R. T. Co.'s equity in construc- tion, advances on leased lines..
144,687	8,225,489
Sundry charges prepaid.....	Accounts to be adjusted.....
105,909	215,765
	Profit and loss, surplus.....
	434,827
Total.....	Total.....
\$11,696,789	\$11,696,789

Financial Notes

The Philadelphia Rapid Transit Company is building two enormous car barns, at a cost of \$500,000.

Plans have been completed for a 40-mile interurban line from Decatur, Ind., to Springfield, Ill.

The directors of the North Jersey Street Railway Company recently decided to perpetuate the company's charter.

A charter has been asked for a 10-mile electric railway from Hampden to Stockton Springs, Me., on Penobscot Bay.

The Cooley Epicyclonical Engine and Developing Company has been incorporated in New Jersey, capitalized at \$25,000,000.

Charles O. Kruger has been appointed general manager of the Philadelphia Rapid Transit Company, which company controls the entire street car service of the city.

The Indianapolis & Cincinnati Traction Company has been incorporated, capital \$1,500,000, to build a line from Indianapolis through five towns to Brookville.

The corporation of Glasgow has accepted the bid of the British Westinghouse Company for the electrical equipment of the surface cars owned by the municipality.

The Stark Electric Company, Youngstown, Ohio, has filed with the County Recorder a mortgage for \$1,000,000 in favor of the Savings and Trust Company, of Cleveland.

The New York, New Haven & Hartford Railroad Company has declared the regular quarterly dividend of 2 per cent., payable March 31 to stock of record March 14.

The Buffalo & Depew Electric Railway has secured right of way to Rochester, and is negotiating for connection and interchange of traffic with the Rochester Railway.

A franchise has been given to the North River Railway Company to operate a trolley to Corinth and Schuylersville, N. Y., in connection with the Hudson Valley Railway.

The annual meeting of the stockholders of the Havana Electric Railway Company,

which was held February 13 at Jersey City, was adjourned until March 6, at 12 o'clock.

President Parson, of the Philadelphia Rapid Transit Company, says that bids will soon be invited on contracts for constructing the subway from Market street to the Schuylkill.

On the authority of a director, it is stated that net earnings of the Chicago Edison Company for the year ended March 31 will show considerably more than 9 per cent. on the stock.

The Maryland Telephone and Telegraph Company, capitalized and bonded at \$1,000,000 each, has been bought by a syndicate represented by the Central Trust Company, of Baltimore.

A new railroad is to be built between Knoxville, Tenn., Sevierville and Kimway, over which both electric passenger and freight trains will run. The line is to be 58 miles in length.

The Arkansas Traction Company, capital \$500,000, has been incorporated to build an electric road connecting Harrison with an extension of the Missouri Pacific, through a rich mineral country.

The Standard Telephone Company, of Atlanta, Ga., has been sold at auction to Robert Alexander, trustee, of the law firm of Alexander & McGill, of Philadelphia. The price paid for the property was \$200,000.

The Mayor of Syracuse, N. Y., has vetoed an ordinance allowing certain extensions to the Syracuse Rapid Transit Company, on the ground that the company will not promise three-cent workingmen's fares during the rush hours.

The St. Louis Transit Company has voluntarily increased the wages of all conductors and motormen, and has also signed an agreement with the men for five years. The action was taken to prevent any possible trouble during the world's fair.

The Cuban Eastern Railroad Company has been incorporated, to operate railroads or traction companies in Cuba. The authorized capital stock is \$2,000,000, and the incorporators are Louis N. Whealton, Stallo Vinton and Frederick B. Maerkles.

The Toronto & Niagara Power Company will ask the Canadian Parliament for permission to increase its stock to \$6,000,000 and bonds to \$5,000,000, to develop 20,000 horse power of electricity at Niagara Falls and transmit it by cable to Toronto.

The Ocean Power Company, of New York, has been incorporated, with a capital of \$5,000. The company proposes "the exploitation of the ocean as a mechanical power, the exploitation of patents on or inventions to utilize the power of the ocean, etc."

The railroad department of the Elmira Water, Light and Railroad Company reports for the quarter ended December 31: Gross earnings, \$41,141; operating expenses, \$29,774; other income, \$260; fixed charges, \$12,364; deficit, \$737; profit and loss surplus, \$5,460.

It is said that representatives of the Everett-Moore Syndicate are buying right of way between Cleveland and Detroit, and will build an electric line through, giving a connection for the Lake Shore Electric Railway and the syndicate's properties in Detroit and to the north.

A Royal commission has been appointed to inquire into the question of the locomotion and transport needs of London and the desirability of establishing some authority or tribunal to which all schemes of railway and street car line construction should be referred.

The reorganization committee of the Lake Street Elevated Railroad, Chicago, asks a deposit of securities so a plan can be formed that will lift the road out of a rut. The bondholders and stockholders who do not approve such a plan can withdraw. The time for deposit expires March 15th.

The stockholders of the Lake Shore Electric Railway, Cleveland, have ratified the re-financing plan of the directors. Of the \$11,000,000 bonds authorized, only \$5,000,000 will be issued immediately. The \$1,500,000 additional preferred stock is underwritten at 60. The bonds are also underwritten.

At the annual meeting of the stockholders of the United Electric Light and Power Company, held February 6th, the retiring board of directors was re-elected, with the exception of Zelah Van Loan and William Bunker, who retired, Caleb H. Jackson and George W. Hibbard being elected in their places.

The Appellate Court affirms Judge Foley's decision in the temporary injunction granted in favor of the Manufacturers' Association

restraining the Chicago Telephone Company from removing its service from such subscribers as refuse to pay more than \$125 per annum, the maximum rate allowed by the franchise.

Telephone statistics are not obtainable for 1892, but in 1899 the companies had 772,989 miles of wire. Three years later, in 1902, they had 1,729,019 miles of wire and 2,525,666 instruments in the hands of subscribers. In 1902 the telegraph companies transmitted 85,000,000 messages, against less than 10,000,000 in 1870.

The Edison Electric Illuminating Company of Boston is said to have purchased the Natick Gas and Electric Company and the Framingham Electric Company. The Edison company has already secured the Somerville and Woburn companies, and is planning to get control of all the suburban electric lighting business.

In spite of its recent assertion that it had abandoned the proposed scheme, the Government of China has again announced that it has decided to assume control of the commercial telegraph line, and the Taotai of Shanghai has formally requested the Consuls to forbid foreigners to purchase shares in these lines.

President M. E. Ingalls, of the "Big Four," is authority for the statement that his company has secured no financial interest in the Cincinnati, Lawrenceburg & Aurora Traction Company. Mr. Ingalls said that, at present, they were not investing in properties of this kind, and he had no idea that they would do so in the future.

The Indianapolis, Columbus & Southern Traction Company has filed a mortgage, to secure its issue of bonds lately sold in the East, to the Trust Company of North America, Philadelphia, for \$1,000,000 5 per cent. 20-year bonds, to provide for extensions and betterments. At present only \$300,000 of the bonds will be issued.

A deal is said to have been consummated in Springfield, Ill., by Clark Brothers, of Philadelphia, who are reported to have bought all the street car lines, as well as the electric light and power plants, of the city. It is believed in East St. Louis that the firm above mentioned will connect their East St. Louis and Springfield lines.

The fight of long standing between the local Washington (D. C.) telephone company and the Subscribers' Association has been ended, and the company has agreed to pay all costs of the litigation and refund one-half the excess of tolls it collected over the amount named by the law. The amount refunded will be about \$500,000.

There has been over \$100,000 already spent on the new shops of the Detroit United Railway, and they are rapidly being put into condition. President J. C. Hutchins is quoted as saying that it is possible that the Detroit United may build its own cars when the shops are completed, as they will be the finest of the kind in the country.

It is understood that the controlling interest in the Somerville (Mass.) Electric Light Company has been purchased by the firm of Stone & Webster, of Boston, at \$185 a share. The company has a capital stock of \$275,000 and bonds outstanding to the amount of \$50,000. The stock has sold as low as \$70 during the past two years.

The Cumberland Telephone Company reports for the year ended December 31, 1902: Gross earnings, \$3,070,162; increase, \$427,000; net earnings, \$1,001,999, increase \$153,893; fixed charges \$219,813, increase \$9,770; balance \$782,186, increase \$144,123; dividends \$623,203, increase \$154,665; total surplus December 31, 1902, \$893,068, increase \$158,983.

The Fidelity Trust Company has been made the transfer agent in Louisville, Ky., of the Rochester Railway Company, and, as soon as the forms can be printed, stock for Louisville will be issued in exchange for the certificates now held there. A great deal of Rochester preferred is held in Louisville—considerably over one-fifth of the issue of \$2,500,000.

Secretary of State Cook has issued a charter to the Central Missouri Electric Railroad, with a capital of \$4,000,000. The road is to extend from Brookfield to Glasgow, and thence to St. Louis, a distance of 194 miles. Col. W. N. Chase, of New York, is the principal financier of the road. The line is to be completed in time for the World's Fair.

A. L. Rich & Co., of Cincinnati, and the First and Third National banks of Louisville, have underwritten the \$500,000 stock and the same amount of bonds of the Louisville Suburban Railway Company, which is projected to run from Louisville to Mt. Washington, a distance of 21 miles. This will be the first traction road to enter Louisville. The third-rail system is to be used.

The contracts for the cast iron lining for the two tubes of the East River tunnel, which is to extend from the Battery to Joralemon street, Brooklyn, has been let to the Davis & Thomas Company, of Cheasauqua, Pa. The contract calls for about 20,000 tons of material. Work will begin in April and will probably continue for two years. The amount of the contract is about \$1,000,000.

January earnings of the City Railway Company, Chicago, are said to have made excellent gains over the same month a year ago. Figures are not available, but it is said that the volume of traffic compares very favorably with the months that are naturally better adapted for surface line street car traffic. February has not started in so well. Two heavy snowstorms have been very expensive.

In the State House of Representatives of Connecticut Senator Ney presented a bill on February 6th for the incorporation of a trust company in Hartford by attorneys for the projected third-rail railroad between Hartford, Middletown and New Haven, the capital stock to be within \$10,000,000. The trust company, it is understood, is for the purpose of financing a projected parallel to the New Haven road.

A conference was held February 6th between officials representing the Louisville Railway Company, the Louisville Gas Company, the Louisville Electric Light Company and the Citizens' General Electric Company. This fact is considered strong evidence that a merger of these companies will soon be effected. All of them are at present maintaining separate power plants, and a combination would materially reduce operating expenses.

It is reported that Anthony N. Brady and others are considering the formation of a holding company to take over the Louisville Gas Company, the Louisville Electric Light Company and the Citizens' Electric Light Company, of Louisville. While the details are not yet arranged, it is probable that the new company will take over the \$925,000 of gas stock now owned by the city that a recent act of the Legislature empowers the city to sell.

The Marconi Wireless Telegraph Company, London, Eng., has applied to the courts for sanction for the extending of the purposes of the corporation, to include recent developments. The company states that it will shortly be able to send messages completely around the earth. It also states that it hopes to apply the system to heating and traction. The company, in its application, mentions its purpose to publish daily papers on ocean liners.

Well known Canadian capitalists have incorporated the Mexican Light and Power Company, Ltd., with a capital of \$12,000,000 stock and \$12,000,000 5 per cent. bonds. Of the stock \$7,500,000 is fully paid and \$5,000,000 bonds are to be issued now. The company will develop 40,000 horse power in the Sierra Madre Mountains and transmit it by electricity 95 miles to Mexico City. The company is now offering its stock and bonds in the Montreal market.

The Capital Traction Company of Washington, D. C., reports for the year ended December 31, 1902: Gross earnings, \$1,381,033; increase, \$149,350; operating expenses, \$631,987; increase, \$71,816; net earnings, \$749,046; increase, \$77,534; other income, \$21,007; increase, \$1,340; total, \$770,053; increase, \$78,864; interest and taxes, \$116,105; increase, \$4,305; balance, \$653,984; increase, \$74,559; dividends, \$480,000, unchanged; surplus, \$173,947; increase, \$74,558.

Advices from England say that the British postal telegraph authorities will order an extension of the Government land lines to the Poldhu station of the Marconi Wireless Telegraph system, in Cornwall, England. Heretofore the telegraph lines ended at a town two miles distant from the Marconi station, and all messages had to be transmitted between the Marconi station and the Government telegraph station by messenger, thus causing great delay.

The Madison County Gas and Electric Company, of Oneida, N. Y., reports that the surplus earnings for the year 1902 nearly doubled its dividend requirements on its preferred stock. The estimated surplus earnings for the current year, based on contracts now on hand, will show three times its dividend requirements. Lawrence Barnum & Co. are offering the company's 6 per cent. cumulative preferred stock at 85 and accrued dividend yielding 7 per cent.

A syndicate has taken over the Consolidated Railway Company, the Gas and Electric Light Company and the Hot Water Heating Company, of Springfield, Ill. Options on the properties expire March 5. The new company will issue \$3,000,000 of 5 per cent. bonds and \$3,000,000 stock. It will be named the Springfield Railway and Light Company. The negotiations have been made by King, Hodenpyl & Co., of Chicago, and E. W. Clarke & Co., of Louisville.

The daily average traffic of the Metropolitan Elevated Railway, of Chicago, for January was 112,171 passengers, as compared with 98,020 in the same month a year ago. The increase was 15.4 per cent. The South Side elevated traffic for January was 86,637 passengers daily, or an increase of 7,483 passengers, or 9 per cent. The daily average traffic of the Northwestern elevated for January was 68,266 passengers, compared with 62,010 the same month a year ago. The increase was 10.09 per cent.

Senator Russell, in the New York State Senate, introduced a bill on February 10th amending the Greater New York charter to provide for the appointment of a Board of Railroad Commissioners of the City of New York by the Mayor, for a term of six years,

at a salary of \$5,000 a year. Assemblyman Wood, on February 10th, introduced a bill providing for the appointment of a three-headed railroad commission for New York City, the commissioners to serve for six years, at a salary of \$5,000 a year. They are to regulate railroad traffic in New York City.

Representative Henry C. Smith (Rep. Mich.) has introduced a resolution declaring that the Postal Telegraph Company has combined or conspired with others for the purpose of monopolizing or controlling telegraphic communication and tariff rates, in restraint of trade, and has granted franking privileges for the purpose of unlawfully influencing sentiment through the press. In view of this alleged condition, the resolution directs that the Committee on Elections of the President, Vice-President and Members of Congress make an investigation and report to the House of Representatives.

The new power house of the Brooklyn Rapid Transit Company is so near completion that the company expects to have both engines started by this month. When this is in full operation the company will have power enough to last them for this year and to relieve them from many of their present difficulties occasioned by lack of power. This power house, however, will not be large enough to supply the wants of the company when its future plans are more generally carried out, and still another and larger power house is now proposed, and for this latter the company has already secured an available site.

An effort is being made by a group of capitalists at St. Louis, headed by the Orthweins, to build a telegraph system between the principal cities of the country. The first venture is to be a line connecting Chicago, St. Louis, Kansas City, Minneapolis and St. Paul. To secure an entrance into Chicago an option has been taken on the Chicago & Milwaukee Telegraph Company, which has a line to Milwaukee, and which controls a subway entering Chicago. Orthwein is in Chicago interesting the brokerage houses. About \$500,000 has been raised in St. Louis to further the venture, and it is sought to raise \$1,250,000 here.

Some weeks ago several daily papers of this city printed a statement that the Marconi Wireless Telegraph Company had made a contract with the United Fruit Company for the establishment of wireless telegraph stations throughout Central America. The statement was denied at the time by the De Forest Wireless Telegraph Company. Since then the latter company has received a communication from the United Fruit Company which says that there has been no contract entered into by that company for any system

of wireless telegraphy beyond an agreement with the De Forest company respecting two stations to be established.

It is understood that the \$1,973,000 additional General Electric Stock, for which application to list was made to the New York Stock Exchange on February 19th, will be used in the purchase of the Stanley Electric Manufacturing Company, the General Electric stock to be given in exchange for that of the Stanley company. The \$1,973,000 is a part of the additional stock that was authorized in May of last year, and will make the total amount listed \$43,974,500. The total authorized capital, according to statements submitted at the time of the stock dividend last year, was \$44,999,500, practically \$45,000,000. This would leave in the treasury \$1,024,900, excluding the amount to be listed.

A gentleman who is connected with the United Metals Selling Company says: "Since the first of January it cannot be denied that there has been a better demand for copper than for over a year. I should not like to venture a guess as to the amount of surplus copper in this country; but, at any rate, prices would indicate that stocks in the hands of consumers are very low; that consumers had been purchasing from hand to mouth, and that, in order to keep their mills in operation, they have had to purchase freely at prevailing prices. No lake copper is offered below 12 $\frac{3}{4}$ cents and no electrolytic below 12 $\frac{5}{8}$ cents. A large amount of lake copper has sold the past week at 12 $\frac{5}{8}$ cents."

The new financial arrangement of the Maryland Telephone and Telegraph Company has been approved by the stockholders. It is intended to issue sufficient bonds to provide for the future needs of the company, including the extension of all its lines and the liquidation of the entire floating debt. The present capitalization is \$1,000,000 of common stock and \$1,000,000 5 per cent. mortgage bonds. It is understood this is to be increased \$1,000,000, to be divided equally in bonds and common stock. C. I. T. Gould, Robert Ramsay, Frank A. Furst and Frank H. Calloway were elected directors to succeed Stanley Baker, Seymour Mandelbaum, E. H. Bouton, William L. Marbury and J. William Middendorf.

The vast importance of the electrical enterprises in this country to-day may be appreciated to something like their full extent when it is considered that \$4,000,000,000 of money is invested in them, as stated by President Scott at the annual dinner of the American Institute of Electrical Engineers. This is equal to one-third the sum invested in the 200,000 miles of railroads in the United States, and it has been all expended practically within the last fifteen or twenty years,

while the railroad expenditures cover more than half a century that is rightly regarded as chiefly notable for its rapid development of the transportation facilities of the Continent. The probabilities are that in another fifteen or twenty years the value of electrical undertakings will exceed the value of the railroads.

It is reported here that R. R. Govin and Joseph S. Auerbach, representing the eastern interests in the Chicago Union Traction Company have in their possession a proposition to provide the city of Chicago with a subway system similar to that now being constructed in New York. According to the report, John A. McDonald, the contractor who is building the New York subway, is willing to undertake the feat, and it is understood here that sufficient financial backing has already been promised. It is further reported that some time ago a corps of prominent engineers looked over the streets of Chicago, with a view to the feasibility of constructing a subway. The engineers are said to have reported that, as an engineering proposition, a subway for Chicago would be comparatively easy, and that the question of drainage would be the principal point to be considered.

It is the intention of the Marconi Wireless Telegraph Company, of Canada, to establish a plant at or near Montreal for the manufacture of the instruments and equipment used in the Marconi system. The works of the English corporation, at Chelmsford, are now running to the limit of their capacity, and are far behind in the orders. The present rush orders are for equipment to be placed on trans-Atlantic steamers. The Canadian company intends to install its series of stations along the lower St. Lawrence, with the aid of Government subsidies. This work cannot be delayed. Andrew A. Allen, of the Allen Steamship Line, and F. C. Henshaw, of the Richelieu & Ontario Navigation Company, who are both directors of the Canadian Marconi corporation, are pushing the lower St. Lawrence plan, because the ships in which they are interested operate on those waters, and the danger to navigation is very great.

It is stated that arrangements have been perfected by the American De Forest Wireless Telegraph Company to establish their system on the Great Lakes, and contracts have been made for the erection of wireless stations in all the important cities in that region. It is also the intention of the American De Forest Wireless Telegraph Company to push the work now in course of construction at all the coast ports on the Atlantic. The stations at Block Island and Newport are almost completed, and will shortly be ready for operation. Plans are also under way for establishing wireless tele-

graph systems between New York and a number of the larger cities contiguous to New York. At a meeting of the board of directors to be held soon S. S. Bogart, for sixteen years identified with the Western Union Telegraph Company, and formerly superintendent of that company, will be elected a director of the American De Forest Wireless Telegraph Company.

The sum of \$1,125,000, representing the entire capitalization in preferred stock of the Cincinnati & Columbus Traction Company, has been set aside by the subscribed stockholders, subject to the instant demand of the company. The financing of this promising traction enterprise was concluded recently, and the work of arranging for the early construction of the line to Hillsboro is well advanced. The preferred stock of the company was placed at \$1,250,000, this stock going to the subscribers at 90 cents on the dollar. Not a dollar of out-of-town money was needed for the road, the proposition looking so promising to local traction investors that the issue was disposed of with little solicitation. The management expects to be able to build the 51 miles of its road with this sum, notwithstanding the fact that iron and steel rails and equipment are well up in price, as is nearly everything else used in traction construction.

The United States Light & Heating Company elected the following directors at their annual meeting, held at Jersey City, February 16th: R. H. Beach, of the General Electric Company; Leroy W. Baldwin, president Empire State Trust Company, of New York; Joseph Leiter, Chicago, Ill.; W. K. Gillette, president Denver & Southwestern Railroad Company; A. Sandford Adler, New York; C. S. Drummond, managing director of the London Traction Company, London, Eng.; Charles S. Furst, Jersey City, N. J.; J. S. L'Amoreaux, Wallace Young, W. J. Arkell and John J. Gilbert, all of New York. R. H. Beach was elected president of the corporation; W. J. Arkell, vice-president; Chas. S. Furst, Jersey City, secretary and treasurer, and A. Sandford Adler, general manager. It is understood, by Mr. Beach taking the presidency of this corporation, that the General Electric Company is to make all the electric machinery for this company.

The Cuyahoga Telephone Company reports for the year 1902, gross earnings, \$385,852; expenses, \$210,289; net earnings, \$175,563; taxes, \$19,421; balance, \$156,142; interest and depreciation, \$155,600; surplus, \$542; deficit December 31, 1901, \$26,482;

deficit December 31, 1902, \$29,142. The general balance sheet as of December 31, 1902, shows:

Assets—Property and plant, \$5,714,242; material and supplies, \$60,616; current assets, \$101,725; deferred assets, \$1,756; total assets, \$5,878,339; deficit, \$29,143; total, \$5,907,482.

Liabilities—Capital stock, \$3,000,000; bonded debt, \$2,233,000; current liabilities, \$196,047; Federal Telephone Company, \$475,392; deferred liabilities, \$3,043; total liabilities, \$5,907,482.

The election of the directors of the company for the ensuing year, held February 5th, resulted in the re-election of the old board, with the exception of N. A. Gilbert. In his place J. R. Sprankle was elected. The directors elected the following officers: President, F. S. Dickson; vice-president, E. W. Moore; secretary, J. B. Hoge.

To raise the \$400,000 necessary to make improvements and betterments President Dickson proposes a subscription by the stockholders at 60 to an issue of \$2,000,000 worth of 6 per cent. cumulative preferred stock. The plan provides for the Federal Telephone Company to liquidate its claims against the Cuyahoga by the acceptance of 7,415 shares of this stock. The bondholders are also solicited to subscribe for three shares for every bond held, and the remainder, consisting of 5,886 shares, to remain in the treasury, not to be sold for less than 75. President Dickson says: "We can operate this company, as it now is, with economy and care, and pay our running expenses and bonded interest, but we can do no more unless we can extend and improve the service so as to justify an increase in rates. Your directors and officers will be powerless unless they are supported loyally by the stockholders."

The stockholders were informed by President Dickson that the plan to pay off the Cuyahoga debt of \$475,392 to the Federal Telephone had not met the approval by the bond receipt holders. This expenditure was made by the Western Reserve Construction Company. It was expected that the work would be completed and enough 'phones installed to allow the Cuyahoga company to issue bonds and cover the expenditure. The financial troubles of the Everett-Moore Syndicate, however, put a stop to this work, and the debt now stands, with no immediate possibility of being met in the way intended.

Concerning the reply of the bondholders, Mr. Dickson said: "On the 28th of January I received a formal reply from the bondholders' committee, giving me to understand that we could look for no support from that source, and that if this company was to be financed it would have to be done by the stockholders, and not by the bondholders."

LIBRARY
OF THE
UNIVERSITY OF ILLINOIS

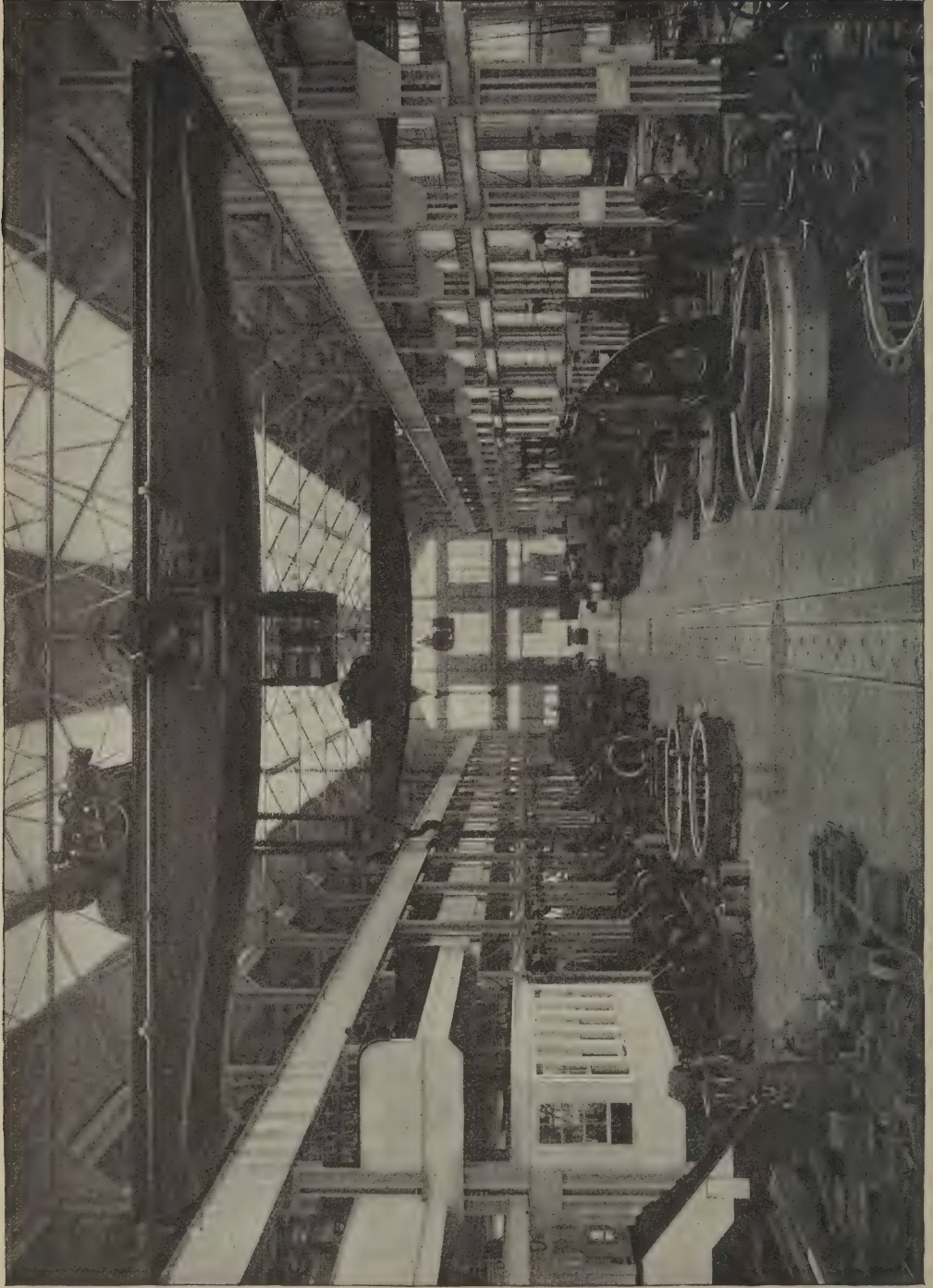

A Modern Machine Shop, Showing Two Forty-ton Cranes and Tools Driven by Electric Motors.

THE ELECTRICAL AGE

NEW YORK

VOL. XXX

APRIL, 1903

No. 4

Electrically Driven Machinery

By WILLIAM BURLINGHAM, U. S. N.

DESPITE extensive opposition, or rather inertia, among our manufacturers, the electric drive for machine tools has steadily made a name for itself. Even now it is comparatively little used, considering the immense number of manufactories in the country; but the entering wedge has been deeply driven, and the results are very promising. The problem is still a new one, and as yet only partially solved; in fact, it is only during the past year or two that it has been recognized as a problem. The installations of power plants at Niagara and other water powers have given a great impetus to this method of driving, and its inherent good qualities, even under the disadvantages of motors unfitted for the service or machines too weak for the new drive, have more than counterbalanced the disad-

vantages of an installation, the details, and even the principles, of which are not thoroughly worked out.

To complicate matters the new tool steels have so revolutionized the cutting speeds of our machines that the motors designed for the tools of a few years ago are lamentably under size.

The original idea of powering a machine with electricity consisted of bolting the motor to a bracket, after guessing at the power required. It is true that an attempt was made at calculating the requisite power, but from the usual results one would think that a good guess would have been better.

It is only lately that experiments have been made for the purpose of determining the power necessary to drive the different types of tools, and, until the installation of the electric motor, with its

ampere and volt meters, it was practically impossible to determine this power unless an expensive and unsatisfactory pony brake was rigged up. Even with this arrangement only an expert could approximate a satisfactory result, the most reliable public data being those published by our technical colleges.

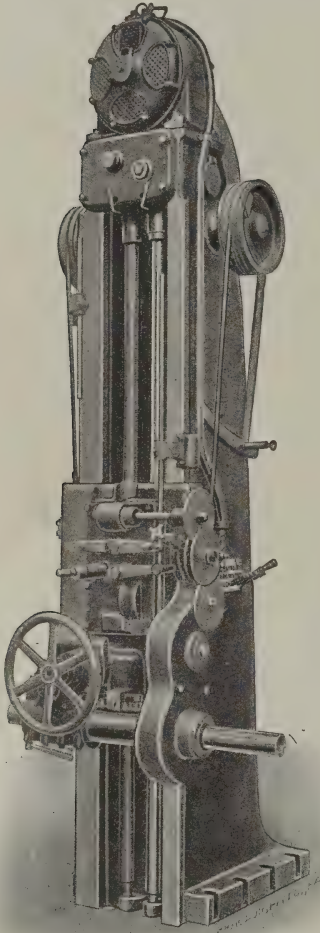

Alternating Current Motor Driving Portable Vertical Drilling Machine.

The many late experiments have shown us that our tools, although well designed for belt drives, are in most cases utterly unsuited for modern power

drives. The real fact of the matter is this: the installation of the electric drive will alter the design of the entire driving gear of our machine tools, and the sooner electrical engineers and tool designers appreciate this fact, the quicker will electrically driven machinery displace the old methods of driving. It is of no use to place large motors on our present machines, as the men on piecework will drive the machines to destruction; breaking gears, springing shafts, and generally throwing the tool out of gear.

With a small motor as driver, they usually overload them, when possible, and burn them out, or else there is a kick to the electrical manufacturer concerning his stupidity in putting such a small motor on the tool. Thus there is no satisfaction for the electrical contractor, machine shop owner, or working machinist.

Where by accident or design the tool and motor were perfectly suited to each other, the Taylor-White and similar tool steels have been installed with the result that everything but the point of the tool breaks.

Therefore, in designing our modern machine tool we must to-day consider three things: 1st. The right motor; its maximum power, its capacity of economical speed variation, and an ample power at a low number of revolutions; 2nd. The right design for the driving mechanism of the tool; strong enough for full power of the motor, ample stiffness, and large bearing surfaces; and 3d. If high grade tool steels are to be used, machine and motor must be designed to hold up under the high rate of cutting speed that these tools demand.

At the present writing the interests of the electric drive center almost entirely in the powering of machine shop tools. There are isolated cases, in driving printing presses, etc., but the great field of

our factories and general industries, as differentiated from our machine shops, has hardly been touched. It is for time and experience to demonstrate to the owners of these places the advantages of the electric drive.

In the majority of cases, the machine

signers and electrical motor manufacturers meet each other half way, then will be evolved the best machine, but at present there are many cases in which neither side will change their preconceived design, and consequently the tool buyer suffers, although I must say that I

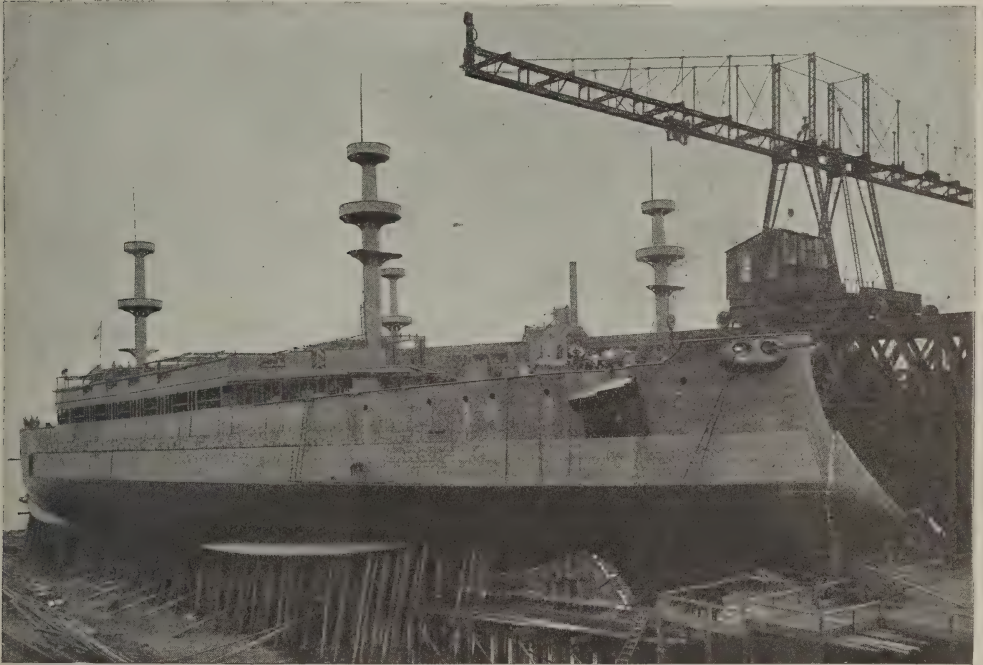

Cantilever Crane, Operated by Two 60 H. P. Motors, at Newport News—Battleships "Kearsarge" and "Kentucky."

shop plants that have been fitted with the electric drive have been copied directly from the old belt drive methods; that is, driving by belt from a motor used in place of the countershaft and steam engine. This is better than the old way, but it is not appreciating the capabilities of the electric motor or using it at anywhere near its full value.

It is true that the moment we install an electric motor, directly coupled to the tool, manifold difficulties crop up during the working operation, and we hear the words, "Why wasn't this or that thought of?" Needless to say, it is impossible to improve on anything that has not yet been designed. When the tool de-

have found the motor people more amenable to argument than the tool designers. Naturally, the arguments for and against the use of electricity as a motive power in machine shops, obtain almost entirely for descriptions of other manufacturing plants which are to be motor driven.

The advantages claimed for the system of electric driving may be divided into four general heads:

First—Saving in cost of power.

Second—Increased flexibility of the system.

Third—Increased output.

Fourth—Improvement in the personnel of the men. Saving in the cost of power.

The latter is the factor that usually looms up the highest in the eyes of the prospective buyer, although in comparison with the other factors it is the last one that should be considered. At the beginning it was the argument that made electric installations possible, but the

go to make up this saving are as follows :

a. The large decrease in the amount of line and counter shafting necessary, with a corresponding decrease in the power absorbed by friction and lost in turning this mass of shafting, pulleys and belting, loaded or unloaded.

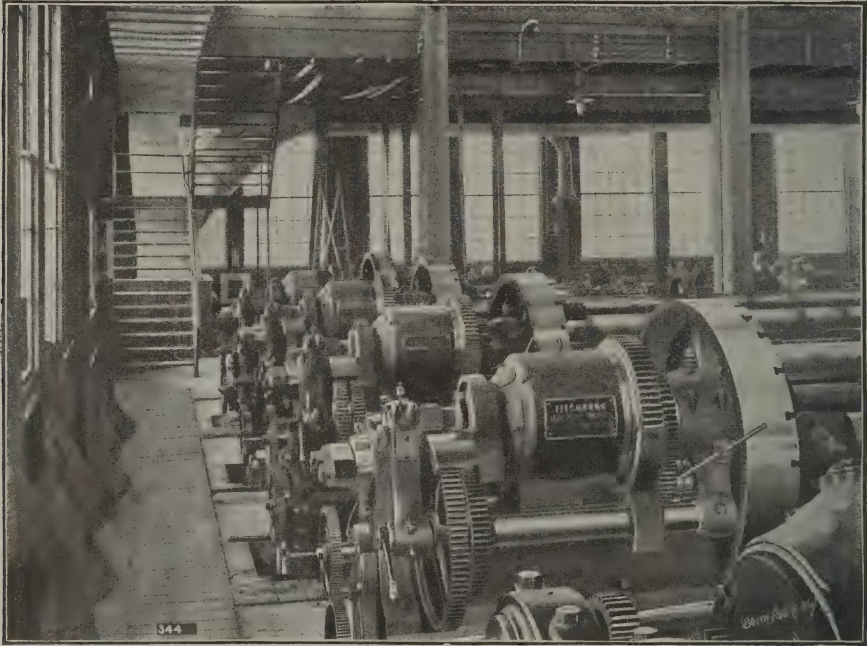

Motor Driven Lathes in Main Machine Shop of Fore River Ship and Engine Company.

other and greater advantages that experience with the motor system has found to be possible, have steadily relegated this " saving in cost of power " to the background. The actual factors that

Professor C. H. Benjamin read an exhaustive paper before the American Society of Mechanical Engineers in 1896 that gives these losses in extenso. They are as follows :

	Length of Line Shaft	Total H. P.	H.P.to Drive Shaft, Etc.	Per Cent.	At What Capacity
Wire drawing and polishing	1,130	400	157	39	one-half
Stamping and polishing	580	74	57	77	one-third
Boiler and machine tools	530	38	25	65	two-thirds
Bridge machinery	1,460	59	48	81	nearly full
Heavy machine tools	1,120	112	64	57	full
Heavy machine tools	1,065	168	91	54	"
Light machine tools	748	40	20	51	"
Manufacture of small tools	500	74	40	54	"
Manufacture of small tools	990	47	24.5	51	"
Sewing machines and bicycles	2,400	190	108	57	"
Sewing machines	1,472	107	75	70	"
Screw machinery	1,800	241	114	47	"
Steel wood screws	674	117	17	14.5	one-quarter
Manufacture of steel nails	988	91	45	50	full
Planing mills	165	39	28	73	"
Light machine tools	275	8	4	50	one-half

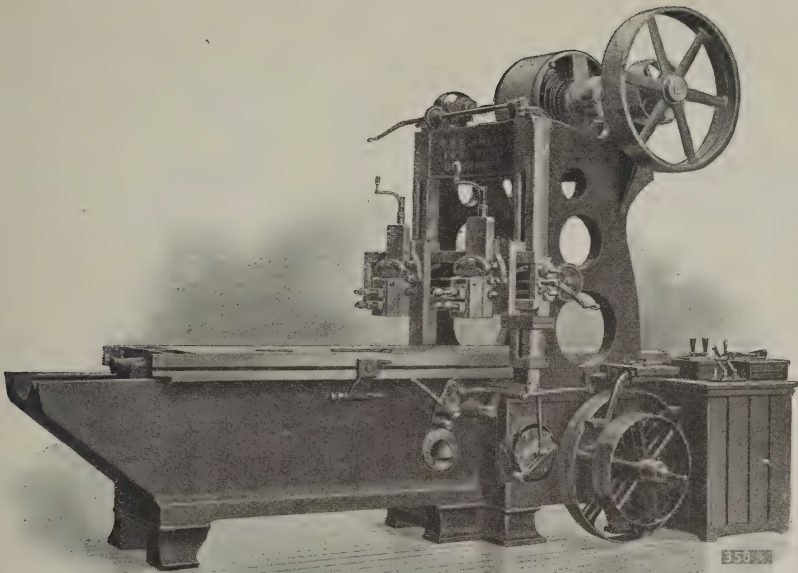

Electric Motor Mounted on Planer.

Professor Benjamin analyses these figures as follows: For machines working full capacity, every 100 indicated horse power of the engine may be distributed as follows:

Friction of engine,	10 H.P.	or	10 p. cent.
To drive shafting,	15 H.P.	"	15 p. cent.
Belts and pulleys,	15 H.P.	"	15 p. cent.
Empty machines,	15 H.P.	"	15 p. cent.
Cutting material,	45 H.P.	"	45 p. cent.

100 H. P. 100 p. cent.

In a test of the group system operated by electric motors, taken on a basis of 100 feet of line shafting, the results were as follows:

Motor and shafting.	12 H.P.	or	30 p. cent.
Machines	28 H.P.	or	70 p. cent.

In some experiments of my own the results were as follows:

Motor and machine light.	32.3 p. ct.	power of motor
Cutting, average work.	67.7 p. ct.	power of motor

—which agrees very well with Professor Benjamin's experiments.

b. No loss from slipping of belts.

This is a factor in the older shops with insufficient head room, the importance of which is hardly realized. And these are just the shops that should install the motor drive, as they are generally cramped for room in all three dimensions.

c. In a large plant a lesser number of employees is necessary to manage the power plant, especially if the current is taken from an outside central station.

d. No loss from the condensation of steam in the long pipes that lead from the boiler installation to the various shop engines.

e. The decreased capital invested in the installation and repair of the power conductors; in other words, the use of copper wires instead of steam pipes with their gaskets and flanges.

Professor Chas. E. Emory epitomizes

the ratio of the cost of power to the output of the shop, as follows:

Complete Belt Transmission.

Cost of Steam Power—

At \$36.17.....2 per cent. of product
 At \$24.19...1 2-3 per cent. of product

Subdivided Motors.

Cost of Steam Power—

At \$36.17..... 1 per cent. of product
 At \$24.19.....0.8 per cent. of product

In both cases the ratio is about 1 to 2.

The following abstract from Mr. D. Selby-Bigge's article on "Electric Power in Iron and Steel Works," is of interest in this connection:

Britannia Works, England.
 Cost of Electrical Horse Power Per Hour, Delivered at Switchboard.

Coal at \$2.82 per ton...	\$0.00289	cents
Water at 0.07 per 1,000 gals.	.00014	"
Stores00015	"
Wages0010	"
Repairs00023	"
Superintendence00018	"

\$0.00459

Mean indicated horse power at 75 per cent. efficiency, 773; coal per indicated horse power, 1,705 pounds; water per indicated horse power, 15.4 pounds.

Cost of Electrical Horse Power.
 Works of Richardson, Westgarth & Co., West Hartlepool, England.
 Original Plant—13 engines, 12 boil-

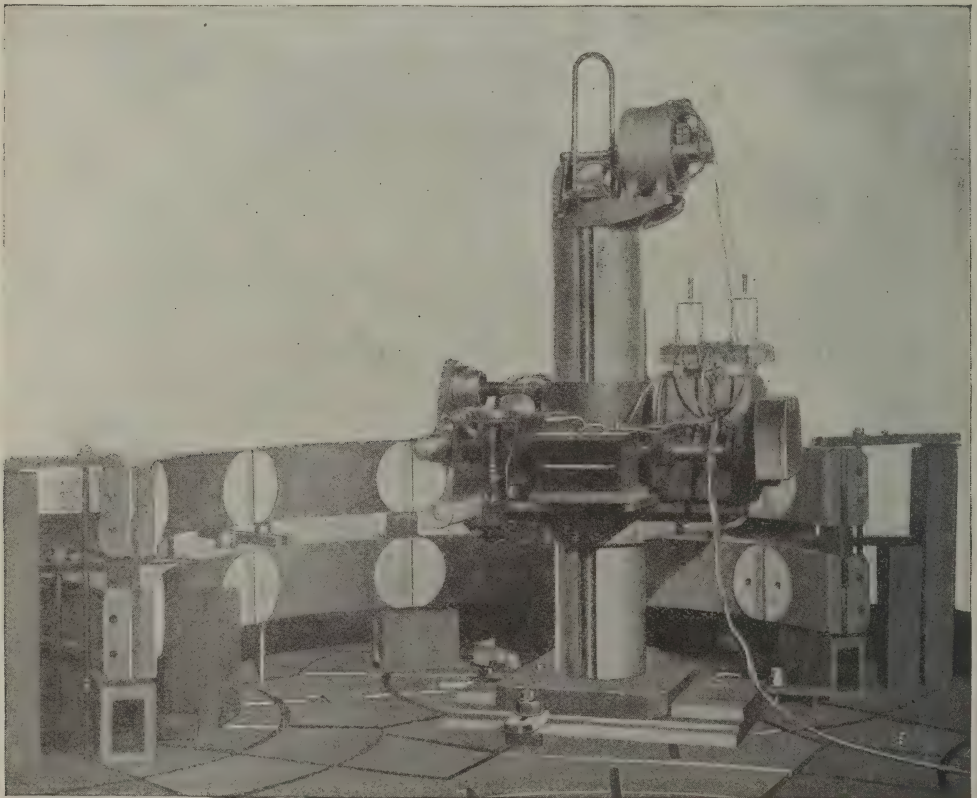

Motor Driven Portable Boring and Drilling Machine.

ers, 300 to 400 indicated horse power, consuming 100 tons of coal per week.

New Plant—Two boilers, 15 feet by 10 feet; 2 400 horse power dynamos, 1 120

the substitution of electricity for steam shows a gain of .43 1-2 per cent. per dollar wages paid, viz.:

Coal and Gas.

Wages	\$315,000
Cost of power.....	11,350
\$0.036 per dollar wages paid.	

Electricity.

Wages	\$614,200
Cost of power.....	12,350
\$0.203 per dollar wages paid.	

From other statements in the article we gather that the increased output from

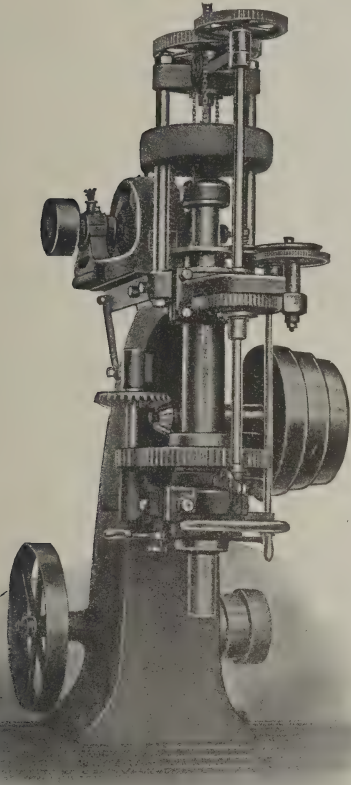

Double Drilling Machine Operated by Direct Current Multipolar Motor.

horse power dynamo, consuming 50 to 60 tons of coal per week.

Thirty per cent. increase in amount of work turned out, with less than 1 per cent. value of installation in repairs in five years. Large engine works; 800 men; 7 1-2 tons of coal per day. Cost per electrical unit, \$0.0093.

Shipyard of N. E. Coast.

One hundred and twelve horse power. Cost per electrical unit, \$0.0121.

At another yard the saving effected by

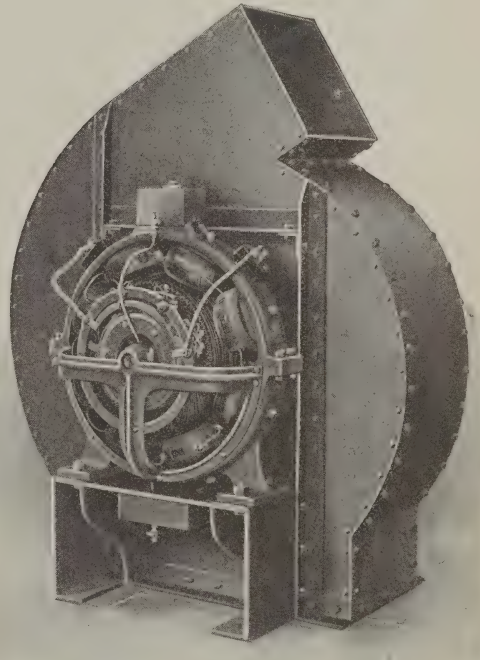

Motor Driven Blower.

the machines since the introduction of electricity has averaged 30 per cent.—and the coal consumption reduced from 40 to 50 per cent.

These figures speak for themselves, and the same favorable results are ob-

tainable in this country as easily as in England.

From the Curtis Publishing Company of Philadelphia, whose plant develops 83,400 kilowatt hours, or 111,510 horse power hours per month, we find that the cost of running this plant for that time was \$1,455.33, 41.3 per cent. of this being for fixed charges; deducting heating cost, averaging \$211.83 per month, leaves a net cost of \$1,244.50, or per kilowatt hour, 1.49 cents, which equals per horse power hour 1.11 cents. This company has its own plant, modern in all its details.

Where a central station is favorably located and conditions favorable, with low rentals or taxes, and abundant water power, with the manufacturing plants using its current in the near neighborhood, the conditions are such that this

central station can furnish current at a figure that would make an isolated plant out of the question.

In these central station plants the use of storage batteries to absorb the power during the morning hours when the work is light, is one of the late economies that are practiced.

The second general head—increased flexibility of the motor drive, is an important one and very conducive to economy. The convenience and small expense attendant to the use of any one tool at any time without the expensive necessity of running every other tool in the shop is a factor in a hurry or repair job that counts on the credit side of the ledger. Even under the system of driving separate groups of tools by a single motor, this factor of economy exists.

There is no necessity for placing the

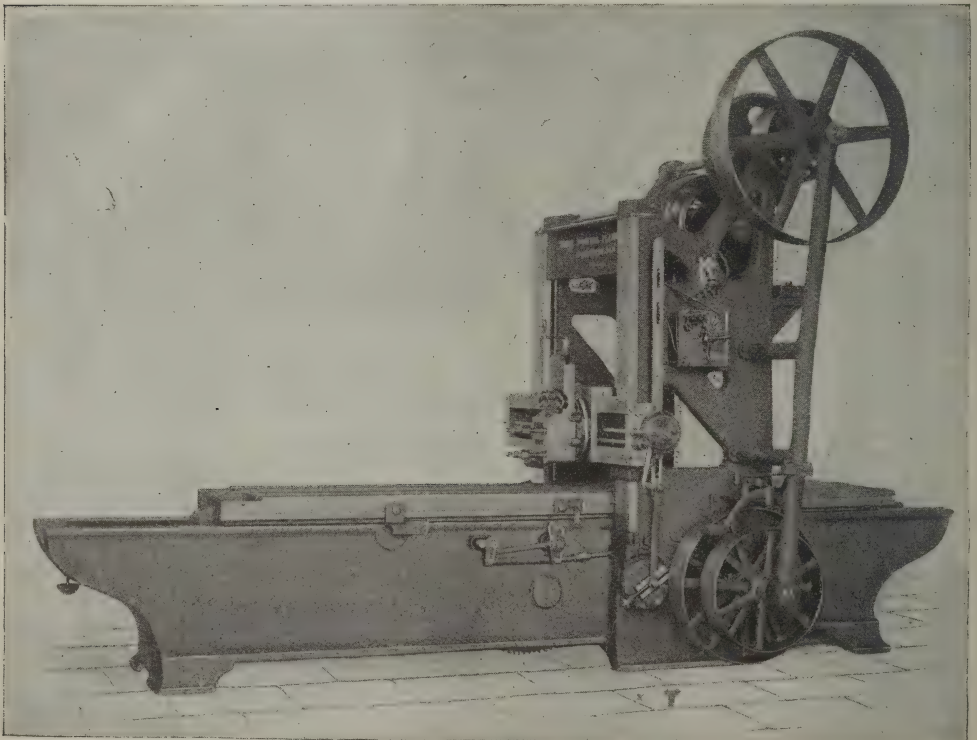

Motor Driven Planer.

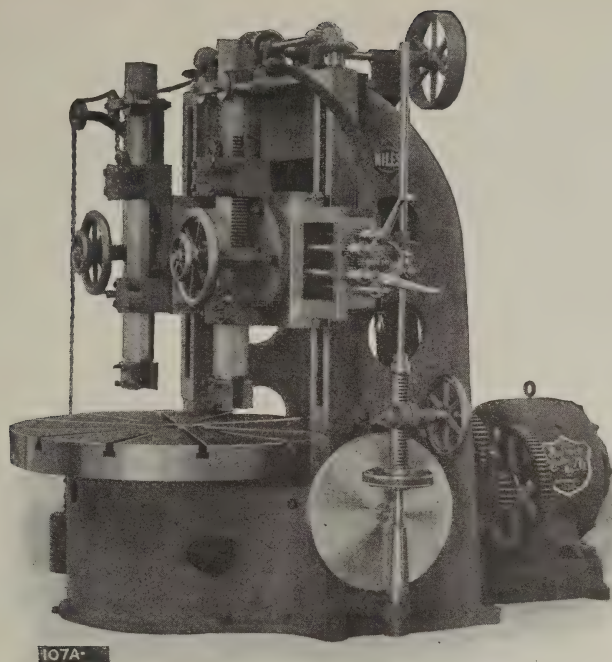

Motor Direct-Connected to Niles Boring Mill.

tools to suit the lines of counter shafting. They can be located as best suits the work they are to do. They may be placed advantageously as regards light and power cranes. For special work they may even be moved; it merely means stringing a couple of wires to the new location.

By reason of the lack of overhead belting, the machines can be placed much nearer each other, and material for them can be handled much easier, as there is no forest of belts to interfere with the swing of the work on the cranes.

Increased Output.—This is a factor that is hard to figure exactly, but experience has proven that the output is increased for the same number of workmen and machines by the installation of each electric motor-driven machine, and it is due to the absolute control that each workman has over his machine, his power to regulate the cutting speed for the maximum output, a manifest impos-

sibility under the old system of stepped cones and pulleys, as it is evident that the great majority of material turned or planed could not except by lucky chance, fit the steps of the speed cone.

Until one has had experience with the advantages of this varying speed system, it is impossible to realize the economy and increased output. The ease of, and room for, handling material is another source of economy, while the increased floor space obtained by the installation of this type of machinery, allows of a greater output per foot of factory floor, quite a factor in some of the plants in our large cities.

The improvement in the personnel of the men also increases the output; this improvement is actual and unexpected in most cases, and it is due to the increased lightness of the shop, by reason of the forest of belts removed, the consequent greater cleanliness of the machines, the ease of manipulating the

tools and a general desire to make the most of the improved facilities at their command. It is hard to say exactly what the reasons are for this improvement, but the fact remains that it is there in all modern shops with electric drive. It must be the same esprit de corps that is of so much use on board a man-of-war, in a political organization or mili-

tary company. All these things are considered by an intelligent superintendent and made use of for the benefit of the company.

I feel as if I had but barely scratched the surface of this subject, and that there are many more arguments favorable to the installation of this system left unwritten.

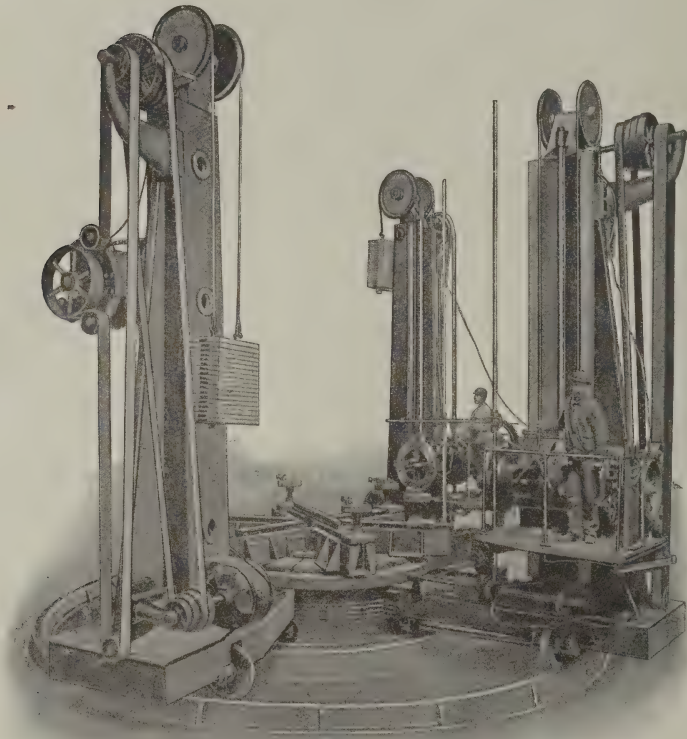

Alternating Current Motor Driving Group of Boiler Shell Drills.

Electric Motors for Machine Tools

By F. A. BLACKWELL

THE equipment of machine tools with electric motors has many advantages, but the strongest point in its favor is that of increased production.

The speed at which any machine tool can be successfully run is limited only by the burning of the cutting tool, and the greatest production is obtained by running as near this point as possible. Where machines must run at various speeds the usual practice has been to employ stepped cone pulleys and changeable gears. The speeds obtained in this way, however, are few in number, and therefore, if a wide range of speed is necessary, the different speeds must be far apart. The minimum speed change of lathes, for instance, is usually from 25 to 50 per cent. If the speed with one combination of gears and pulleys is a little too high, it must be reduced to the next lower speed (25 to 50 per cent. lower) with a loss of output nearly equal to the reduction in speed. If, on the other hand, power is furnished by a variable speed electric motor with a range sufficient to fill in between the mechanical steps, the tool may be driven always at the highest possible speed and maximum production. This is best illustrated by the curves shown further on plotted from a test on a 72 inch lathe.

Curve No. 1 shows the cutting speeds and the time taken to face a 72 inch cast iron disk from a maximum diameter of

72 inches to a minimum diameter of 6 inches, using three different steps on the cone pulley, the time for shifting the belt from one cone to the next not being included. Curve No. 2 shows a test on a similar lathe driven by a motor with field control. The cone pulleys on a mechanically driven tool do not permit the tool to start at the maximum cutting speed and, in this case, the mechanic having no guide but his eye did not change the speed on the cone pulley as soon as desirable for greatest production. With the electrically driven tool, the cut begins and ends at the maximum cutting speed that the work permits.

As will be seen from the curves, the belt driven lathe required 59 minutes to complete the cut, while the motor driven lathe did the same work in 31 minutes. The electrically driven tool therefore did the work in 53 per cent. of the time, or putting it another way, the belt driven tool required 90 per cent. more time to do the same work.

With electrical control all a man has to do is to watch the tool and increase the speed from time to time, being limited only by the temperature of the tool, so that it is found that much higher cutting speeds can often be attained with the motor driven tool than would be thought possible were any fixed rule followed. It is therefore apparent that this increased production in many cases is so great as to fully justify the installation

No. 1

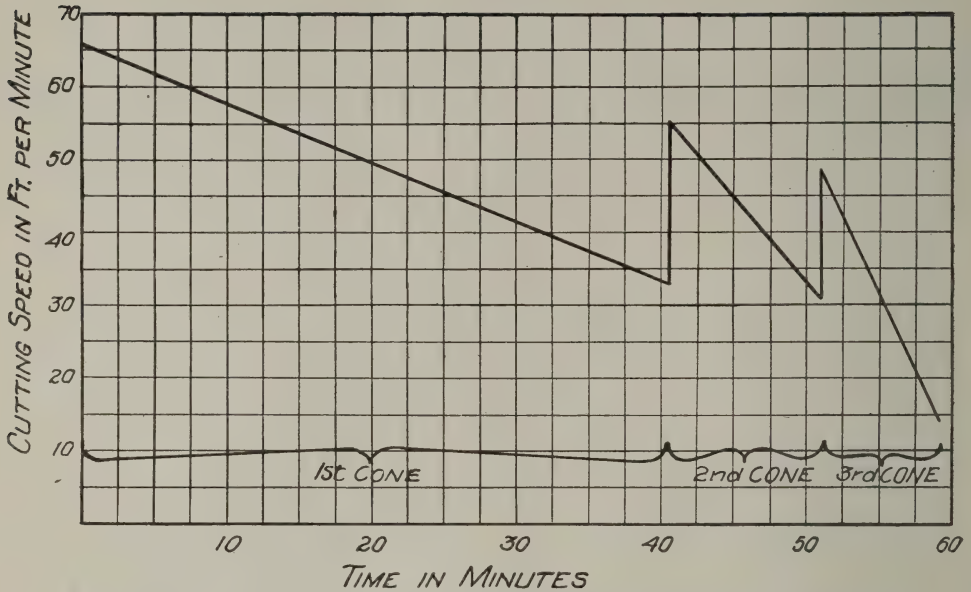

Cutting Speeds and Time Required to Face a 72 inch Cast Iron Disc, using 3 Steps on the Cone Pulley.

of an electric system even if there were no other advantages to be obtained.

The writer wishes to call attention to the methods of obtaining this increased output, and the conditions which limit the desirable range of speed. Machine tools may be broadly divided into two classes: reciprocating, such as planers and slotters, used for finishing flat surfaces; and rotary, such as boring mills and lathes used for finishing cylindrical or similar surfaces.

A reciprocating tool needs only a slight variation in speed, as its work always bears a fixed relation to the cutting speed of the tool, but on a rotary machine tool the diameter of the work and the speed of the main spindle determine the cutting speed, and as the work varies greatly in diameter, a large speed variation of the main spindle must be provided. Assuming the cutting speed to be the maximum permissible without burning the cutting tool, the number of revolutions at which a rotary tool should

be driven will vary inversely as the diameter of the work, that is, a high rotative speed is required for a small diameter and a low rotative speed for a large diameter.

The useful work of a machine tool is determined by the size of the cut and the speed of cutting; or, in other words, it is represented by the weight of metal removed by the cutting tool, and the power required for doing this maximum useful work is the same both at high and low speeds. The torque required to drive the tool, therefore, increases as the speed diminishes, which is self-evident by the accompanying illustration.

The pull required for cutting at a two-foot diameter in "A" is twice that required when cutting at a one-foot diameter in "B," though the speed of "A" would be but half that of "B" to do the same work. Assuming there is no change in the leverage of the driving mechanism, the size of the belt, engine or motor must be twice as great under

the conditions shown in "A" as under those shown in "B." Ordinarily tools are driven from a countershaft running at a constant speed, and cone pulleys and change gears are used to vary the cutting speed so that the torque and horse power are nearly constant. This is also true when the speed of the motor is varied with that of the tool.

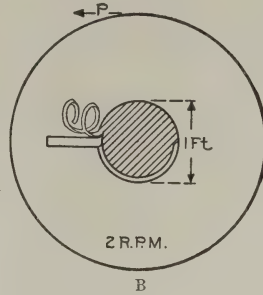
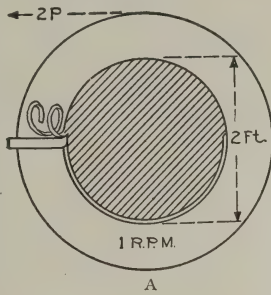

be no greater when the tool is running at a high speed than at a low speed, as there may be a smaller number of gears used.

The following table of actual tests on motor-driven tools shows the power required with a constant cutting speed at various rotative speeds, and it will be

noted that the power taken is nearly constant throughout for the same machine:

In addition to the power required for cutting, is the power required to overcome the friction of the machine, though in a well-designed tool taking the heavy cuts now employed in progressive shops, the friction is often only a small percentage of the total power required to drive the tool when doing its maximum work. When there is no change in the gearing of the tool, the friction torque will be constant for various speeds, but the horse power loss in friction will increase with the speed. When a constant driving speed is used with a variable reduction of gearing to obtain the various speeds on a machine, the horse power required to overcome the friction may

Material	Machine	Chip	Speed of Cutting Ft. per Min.	Horse-Power	R. P. M. On Face-Plate
Cast Iron	26" Lathe	1/8" x 1/2"	75	12.4	24.
"	"	1/8" x 1/2"	75	12.8	36.
Steel	25" Boring Mill	1/8" x 1/4", 2 tools	25	8.75	.9
"	"	1/8" x 1/4"	25	8.6	.4

The greatest advantage in the use of electric power is the fine adjustment of cutting speed which can be obtained by varying the number of revolutions of the motor so as to fill in the gaps between the speeds obtained from mechan-

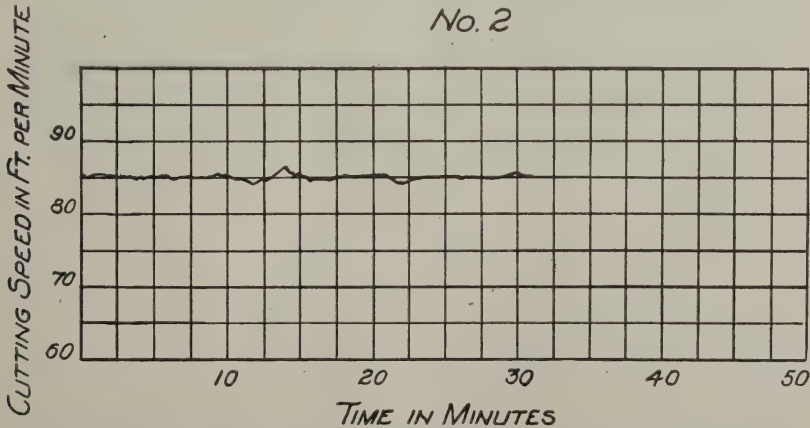

Cutting Speeds and Time Required to Face a 72 inch Cast Iron Disc with Lathe Driven by Motor with Field Control.

ical changes in gearing. It is usual in belt-driven tools to have a mechanical range of speed variation of from 20:1 to 40:1; and this, or even greater variation, could be obtained with an electric motor, but, as already pointed out, there is a limit to which this variation can be carried. The size of a motor depends on the speed and amount of variation for which it is designed, and the cost of a motor which would be capable of giving its full horse power at one-twentieth or one-fortieth of its maximum speed would evidently be prohibitive, and its efficiency under average conditions of work would be extremely low.

The question, therefore, arises: How far is it advisable to carry the electric

speed control? And, in answer, we can say that it is determined to a great extent by the relative costs and sizes of motors of various changes of speed. The methods generally employed for regulating the speed of continuous-current motors are: rheostatic control, control by means of field regulation, and control by means of multi-voltage system.

The most important consideration is to be able to always drive the tool at its highest speed and greatest output, and this is obtained by having a system permitting minute electrical changes of speed which, in combination with the gearing on the tool, will give any speed required.

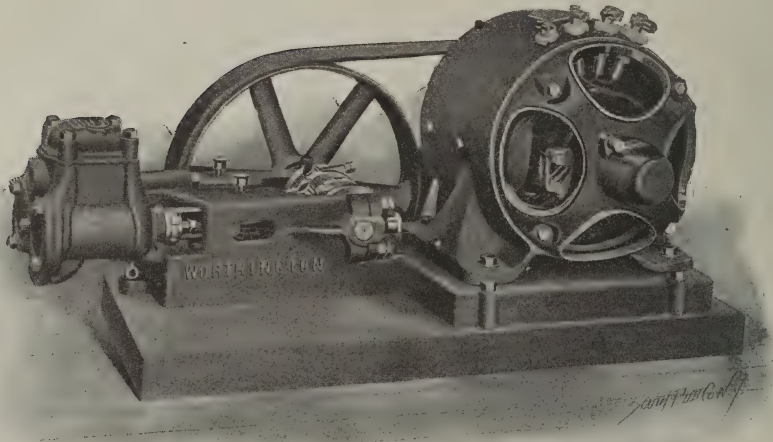

House Pump Driven by Direct Current Motor.

Indicator Practice

By W. H. WAKEMAN

THE steam engine indicator is used for purposes which may be classified under four heads, as follows:

1st. To determine the mean effective pressure in the cylinder, in order that the engineer may calculate the power developed under various conditions.

2nd. To set the valves of engines so that the required power may be developed with the least possible consumption of fuel.

3rd. To set the cut-off on automatic engines, for although the valves may be properly set, the engine will not give satisfaction unless the cut-off gear is correctly adjusted.

4th. To detect defects in steam engines.

The two latter will be considered at this time, as they are sufficient for one article.

especially as live steam was used for various purposes. It was not practical to shut it down and examine its parts, as it was wanted 24 hours per day. Of course, it could have been shut down, if necessary, but the engineer did not deem it advisable to do so if this could be avoided.

When the diagram mentioned was taken it was so different from those usually produced, that repairs were found necessary. This engine is fitted with poppet valves that are closed automatically, the point of cut-off varying according to the load on the engine. Brass bushings are fitted into the ports, which form the valve seats. One of these had become loosened by long use, hence the pressure forced it out when the valve opened, admitting a large volume of steam to the cylinder, as indicated by the high expansion line.

On the return stroke this bushing was forced into place, but inasmuch as steam was blowing through the cylinder during nearly the whole revolution, there was enough present when the exhaust valve closed to produce excessive compression, the result being that as soon as the governor released it, the bushing carrying the valve was quickly forced out of place, causing the pressure to drop immediately, as is very plainly shown by the diagram. After the exact cause of trouble had been located it did not take long to repair the defect.



Fig. 1

The diagram shown in Fig. 1 was taken from an engine that showed signs of some defect, not working as smoothly as formerly. As it was not the only engine in that plant, the extra steam required to run it was not quickly noticed,

The only defect worthy of attention shown by Fig. 2 is the admission line, which leans to the right, as plainly demonstrated, when compared with the vertical dotted line, drawn at right angles to the atmospheric line, after the paper was removed from the indicator drum. Where such a defect is shown on a diagram it is a good idea to draw the verti-

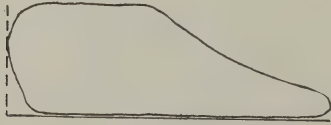

Fig. 2.

cal line before removing the paper, by disconnecting the cord from the reducing motion, admitting steam to the indicator cylinder and pressing the pencil on the paper in the usual manner. If the indicator is in good order, this line will be at right angles to the atmospheric line, but if some defect in the multiplying motion throws this line out of its proper place, it will have the same effect on the admission line; hence their comparative positions will be a true indication of the steam valve's action.

The valve rod on this engine is made in two parts, connected by a brass right and left coupling, held in place by two jam nuts; thus enabling the engineer to adjust the length to give best results when setting the valves. These jam nuts were loosened and the coupling given an eighth turn (which is equal to a quarter turn on a single thread), after which it was fastened in place and another diagram taken, as illustrated in Fig. 3. This shows the admission line at right angles to the atmospheric line, and although the corner is not as sharp as it might be, it is a great improvement over the preceding diagram.

Engineers in charge of engines fitted

with this or any similar device should set the jam nuts up as tight as possible, for they may shake loose, especially if the speed is high.

Fig. 4 illustrates a point concerning the adjustment of cut-off mechanism that is important. The writer believes that the only proper way to do this is to fasten the governor in a position representing an average load, then to take diagrams from both ends of the cylinder and compare the points of cut-off indicated by them. If they are of the same length, no further attention is necessary; but if not, they should be made alike.



Fig. 3.

Of course it is not claimed that the governor will always stay in this position, as changing loads calls for different points of cut-off; consequently the head end will sometimes be the longer, at others the crank end will use the larger quantity of steam. But the average load will be economical so far as the cut-off is concerned, and here the matter must rest.

Some engineers do not admit the necessity for this, as they are sure that the governor must be free to move at all



Fig. 4.

times where the load sends it; then a diagram taken from one end of the cylinder, quickly followed by one from the other end, will show the engineer all that he wants to know along this line.

Now this is proper where the power developed is to be calculated, and it does no harm where the valves are to be set (although it is not essential); but for setting the cut-off on an engine this plan is of no value whatever, as it gives no definite, reliable information, but on the contrary is often misleading.

The pair of diagrams shown in Fig. 4 fully illustrates this point, as one of them was taken, and as soon as possible the valve admitting steam to the indicator from that end was closed and the opposite one opened, after which the other diagram was taken; but the difference between them is very great, for while the forward and the back pressure of the left hand diagram are almost exactly equal, making the mean effective pressure zero, the mean effective pressure of the right hand diagram is 26 pounds, showing that it is doing all of the work.

If we accept this as showing the true condition of the engine, radical changes must be made in the cut-off mechanism in order to balance the load, but this is shown to be a mistaken idea by the appearance of Fig. 5, which illustrates a

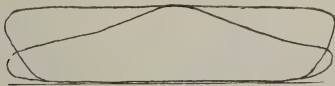

Fig. 5.

pair of diagrams taken soon after Fig. 4 was secured, no changes having been made in the valve gear. The steam pressure was a few pounds lower, but that does not change the adjustment of cut-off gear.

I stated that this cut illustrates a pair of diagrams, but it is a fair sample of several pair; while the preceding represents one pair only; therefore the greater weight of evidence proves that the cut-off is set at least very nearly correct.

There could be no possible doubt about it if the governor had been fastened in place.

Fig. 6 illustrates a pair of diagrams that induced me to think that a bad con-

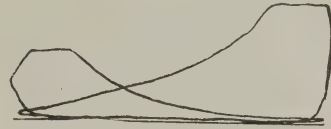

Fig. 6.

dition of affairs existed in the cylinder from which they were taken. The right hand diagram calls for but little comment, as the valves on that end of cylinder are set for good working results, but the left hand specimen is far different. It shows that compression is right, but the admission line indicates a late steam valve, also that it does not open wide enough to give an acceptable initial pressure, as it is far below the right hand diagram. When the highest pressure is reached, showing that the steam valve is wide open, the piston is traveling so rapidly that the port cannot admit steam fast enough to improve matters, and the expansion line is higher than it should be, giving a terminal pressure almost equal to the opposite diagram.

Here was food for thought and investigation, and it was begun at once by reasoning out causes which would produce this state of affairs in one end of the cylinder, and not in the other. It is never advisable to make important changes in an engine on the testimony of one pair of diagrams, and it was not intended to do it in this case, as several specimens should be secured, and they must agree in all essential points before expensive alterations are made. Not being quite sure in which end of cylinder the defects were located, I began to investigate, and found that the right hand diagram was taken from the crank end,

consequently the defective left hand diagram indicated that the head end needed investigation; but while settling this point, I found that the angle valve which admitted steam to the head end was not open wide when Fig. 6 was taken, and subsequent diagrams proved that when this was opened enough to give full area to the passage, all defects in the diagram disappeared.

This incident shows that care must be

exercised to know that every part of the mechanism is in good order and properly adjusted, for if there is any doubt about it the diagrams are of little value, and they are worthless if it is known that the variable motion of the crosshead is not reproduced on the indicator drum, or that any oversight has prevented the pressure which really existed in the cylinder from being plainly written by the pencil.

The Meaning of the City's Growth

DO you realize how rapidly New York City is growing? The Mayor in his recent message to the Aldermen remarked incidentally that the population had increased 100,000 each year since the organization of the greater city, and as five years had elapsed, a city the size of Baltimore had been included in our boundaries. His Honor might have added that at the same rate of progress we take in a Chicago every fifteen years, a Philadelphia every ten years, and a St. Louis, a Baltimore or a Boston every five. Such "little" communities as Cleveland, Buffalo, San Francisco, Cincinnati, Pittsburg and New Orleans are duplicated here every three years. It is only a matter of two years for us to make up sufficient population for Louisville, Minneapolis, Providence, Kansas City, St. Paul, Rochester, Toledo or Columbus, while in any twelve months our growth is sufficient to provide for Syracuse, New Haven, Fall River, St. Joseph, Mo., Omaha, Memphis or Scranton.

While New Yorkers are proud of the town's progress, these references are not

made in a spirit of exultation over our less fortunate neighbors. They are recalled simply to impress the fact upon our city authorities that our growth is so very rapid that it has become all important that they should give adequate consideration to the pressing demands for proper facilities and conveniences to meet the changed conditions. Mayor Low promises to devote a subsequent message to an exposition of the needed improvements. It is to be hoped that he will not delay doing so longer than absolutely necessary, because, with his promise before them, the Aldermen are likely to hold back, pending word from him, thus relieving themselves, in their own eyes at least, of some share of the responsibility.

It is certainly gratifying to observe the energy with which the Rapid Transit Commissioners are providing for the future, or at least preparing plans to provide for the future. Reference is not now made to the work on the subways in course of construction, but even that, notwithstanding all drawbacks, reflects credit on the contractors. The plans of

the commission for new work covering all the boroughs in the great city, and providing for the expenditure of more than \$100,000,000, within the next half dozen years, are most satisfactory and convincing evidence that at least one branch of our government has a righteous and enlightened appreciation of what the coming wants of this community will be. Other departments may well learn a lesson from the Rapid Transit Commission. It may seem that \$100,-

000,000 is a large amount of money for urban transportation, but those inclined to criticize should remember that before the expiration of the six years during which period the money is to be expended, New York will have acquired a new population greater than to-day exists in either St. Louis, Baltimore or Boston. It behooves not only our local government, but also our Albany legislators, to keep well up with the procession. — *Wall Street Summary.*

Manila's Electric Lighting Controversy

By ARTHUR STANLEY RIGGS

Editor Manila "Daily Bulletin"

A VERY long and extremely bitter fight is now being waged in the city of Manila, the largest port in the Philippine Islands, on the local electric lighting company, La Electricista, by a large number of the business houses and private citizens.

At the bottom of the trouble is the old, familiar feeling of jealousy. The sum and substance of the matter is that the company, which is an old Spanish concern, now made up mostly of wealthy Filipinos, is keenly jealous of the success which the American electrical contractors have made in Manila, and so resolved not to have any dealings with them nor with the people who patronized them. The case is now being fought through the courts, and promises, before it has done, to be one of the most interesting three-cornered affairs ever aired in public. One side is represented

by the company, the others by the contractors and the people, respectively, and all want different sorts of justice.

Something over a year ago the firm of Cameron & McLaughlin, general supply dealers and contractors, thought it might be a good plan to put in a stock of electrical goods. A \$10,000 order was, therefore, placed, and in due time the goods arrived and were put on sale. The results were so extremely satisfactory that the firm at once cabled for \$75,000 worth more. These, too, were selling well when other firms, who noticed what their rival was doing, did the same. At this point Electricista stepped in with a statement like the following, which, however, is not quoted verbatim from its circular:

"In view of the fact that we have noticed the cutting of legitimate rates by the American electrical contractors, who

are doing all they can to bring prices down; and because they are taking from us business which it is our right and just privilege to control; and because, for the sake of establishing themselves, they are wiring buildings and doing general electrical contracting for less than it is worth; therefore, we hereby refuse to connect any houses, places of business or edifices of any kind soever, after the first day of next month, that are wired, or in which the electrical apparatus has been furnished or designed by the aforesaid American contractors, or by any other contractors or engineers not in the employ of this company."

That was the bombshell the company threw, and, within 24 hours after it had been published, the contractors were all up in arms, asking the public, through interviews in the daily papers, if it would submit to such arrogant dictation. When it came to taking legal action on the matter there was great hesitation, until finally one merchant, tired of the ways of the company, which has many disagreeable methods, decided, in a fit of righteous anger, to carry the case into court. This he did, and the result was a fine of \$100, gold, for the company and three months in jail for its principal officers for each offence. A multitude of similar suits—many of them brought at the instigation of the City Electrician—were at once filed, the public, apparently, having made up its mind that, perhaps, it might be worth while after all, when the first conviction was so quick and easy. Electricista, however, appealed the case, and threatened to take it to the highest court in the United States. The matter is still pending, but the company would seem to have before it the prospect of bankruptcy, while its

officers may look forward to spending the rest of their natural lives in jail if the sentences are confirmed and executed.

But the company is criticized in many other ways. One of the serious complaints charged against it is to neglect to switch on the current until it has been dark for a half hour. Manila, in common with other tropical cities, has practically no twilight, and the night closes in a bare 15 minutes after the sun sets on the brightest days, while if the day is cloudy or dark, night comes suddenly. This way of doing things works a real hardship in the newspaper offices and in all other establishments, thus seriously interfering with work for a long time just at nightfall, the busiest portion of the day in the tropics. Then, when the lights do come on, they flicker and pump and spit if they are arcs, or glow a dull red, go out entirely, burn on weak current, and do other interesting things if they are incandescents. The nights when this does not happen are the exception rather than the rule.

Still another remnant of Spanish custom is the system of sending around an accredited inspector to examine your lights. He generally informs you, if you have a considerable number of lamps burning, that you have too many; the company has not the current to supply them; that, as the peak of the load drops on to the dynamos like a thunderbolt out of a clear sky, it is impossible for you to have so many lights when, because of this, the company would be obliged to cut some other customer out entirely. He thereupon proceeds, with due solemnity, to cut out all such of your lights as he sees fit. As this seems to be one of the rules of the company, the customer cannot but submit.



Between Whistles

Correspondence from Practical Men upon topics of interest to our readers are especially solicited for this column. Mechanics who have interesting experiences in handling Tools, Machinery, Engines, Boilers and other apparatus are also invited to contribute.

Steam Pumps.

By John A. Lieb.

OF the different methods of feeding the steam boiler, the steam pump is the more generally used, and as it is a machine for hard and reliable duty, it should be of simple construction, easily operated, and designed with a view to accessibility of parts for adjustment and repairs. It should be located in such a manner as to be easy to get at and overhaul, without having to cut down a brick wall to remove the plunger and rod.

Many a pump is considered a failure when the only trouble is a restricted supply of water, for if a suction pipe be obstructed, too small or too long, the pump will be starved. If the velocity or speed at which the plunger is travelling is greater than that of the inflowing water, a partial vacuum will be formed between them, and the plunger on its return stroke will strike the advancing water with a severe blow, which might have serious effects on the joints, valves, etc., of the pipes and pumps.

A partial remedy for this evil is to put a large air chamber on the suction pipe near the pump. This provides an elastic cushion of air for the incoming water to come in contact with, and so not strike the opposite travelling plunger so hard a blow.

The best thing to do, however, is to put in a larger suction pipe, for while an air chamber is always an advantage, it

will not stop the pounding if the water cannot follow in close contact with the plunger.

In the layout of some plants it is often found, in order to have the pump under the eye of the engineer, that an extra long suction pipe becomes necessary. In such cases the pipe should always be one or two sizes larger than called for by the pump connection, and, if possible, the water should have a head.

Should there be a leak in the suction pipe, the action of the plunger will be similar to that above mentioned, except that the shock will not be so great, for the plunger has an air pocket between it and the inflowing water. The first part of the return stroke will be very quick, gradually slowing down as the confined air is compressed, but the shock will be very slight. A very small leak in a suction is an advantage, as it keeps the air chambers charged, which would otherwise become filled with water, as the air becomes absorbed by it.

If there should be a leak in a short and vertical suction pipe, the pump will discharge about equal quantities of air with each stroke, but if the suction pipe is long and horizontal and has a leak near the far end, the pump's action will be spasmodic, sometimes getting solid water and then great pockets of air will flow into it, causing it to dance back and forth several times before getting water again.

If the pump is working against a heavy pressure and there is much clearance, and gets air in large quantities, the compressor may not be sufficient to lift the discharge valves and the vacuum may not be great enough to lift the receiving valves. The action of the pump will now be like compressing and releasing a spiral spring between the palms of the hands. When a pump acts this way, engineers say that the pump has "lost

her water." By closing the valve in the discharge pipe and opening the pet cock, water will appear again.

All pumps with high lifts should have a foot valve just above the water level, so arranged as to be easy of access for repairs and examination. A primer is very convenient, and is simply a small pipe connecting the discharge and suction together; by it the suction and pump can always be charged and ready for instant use.

Hot water or boiler feed pumps.—When water is heated to 100 degrees F. it will begin to boil in a vacuum and produce steam with increasing pressure as the temperature rises until the boiling point in open air is reached, when the pressure of the steam will just equal that of the atmosphere.

Now the sucking action of a pump is not to pull water as one would pull a boat in water with a rope, but is to create a partial vacuum by moving away from the water and allowing it to follow, forced in by whatever pressure there is on it, whether atmospheric or otherwise.

What would be the result of trying to pump water, heated to near the boiling point and contained in a cistern, the water level of which is, say, two feet below the pump? To force this water up to the level of the pump will require one pound additional pressure on its surface; or, what would be the same thing, to remove this pressure from the surface of the water standing in the suction pipe. Suppose the pump is started and it creates a vacuum of one pound; the result is that the water immediately boils and produces steam. Suppose the speed of the pump is increased, so as to pump both water and steam; the action of the pump becomes erratic, for the steam unlike the air, would be condensed by the return stroke of the plunger, and whatever little water has entered with

the steam will be met with a blow like a steam hammer. The remedy is to raise the water level of the cistern in reference to the pump. All hot water should flow to a pump and not have any lift.

In regard to the care of pumps, we would say that there is no piece of apparatus about the fire room which shows good or poor attention as quickly as the average well made steam pump. One may enter one fire room and see a pump doing its duty noiselessly and with no delay at the end of its stroke; it is well cleaned and no leaks are visible. This pump is well cared for. It gets its small but regular dose of cylinder oil and is adjusted only when necessary. More pumps are injured by ignorant adjustment than by any other cause except neglect.

Another fire room is entered, and the pump is in a dark room and very dirty. The water level is going down, but the man is watching it. He wants it to get down as far as is safe before beginning his circus with the pump. Now he opens the steam valve with a whirl; there is a groan and the piston jumps over to the other end and, of course, a little further than its usual travel. This causes it to stick there, and here is where the battered monkey wrench gets in its fine work. The rod lets go, it makes a few lightning-like strokes from end to end without any water. Then priming is resorted to, and finally it settles down to work and won't be stopped until the water is up to the gallery. It's too much trouble to start that pump, or stop it, as long as there is any room for more water.

Now these two pumps were just alike when erected. The trouble has been in the way they have been cared for. The latter has had hard, coarse packing and ignorant adjustment that has worn the rods, making them stick at the ends of

the stroke; they leak out in some parts of their travel and lose suction the moment the pump stops. There is no better indication of how a plant is taken care of than the condition of the steam pump.

Lubrication.

By William M. Davis.

[The following article, which appeared in "Power," is of interest only in a general way. Having some definite data to follow for definite cases, rather than a general statement that a lubricant should not be too thick or too thin, that it should withstand a flash test and a cold test, all of which is already well known, would be something of real value to the operating engineer. What the engineer would like to know is, what is a sufficient flash test, for instance, for cylinder oil under various conditions? We know that, as a rule, the same kind of cylinder oil is used in both high and low pressure cylinders; whereas a much cheaper grade of oil might give much better results in one or the other. Some simple method of making a practical flash test would be welcomed, if, at the same time, it would indicate whether the oil gave off a vapor or changed into an obnoxious gum. Furthermore, an inexpensive engine room method for discovering any objectionable residue in the oil, such as asphaltum, sulphur or grit.

Mr. Davis states that the engineer in charge of a plant will find on the market a great variety of petroleum lubricants to choose from to meet the various conditions which will arise in connection with the proper lubrication of his machinery. This certainly relieves everybody, and every machine, and "puts it up to" the engineer. As a rule, the consumer of lubricating oil neither knows what he wants nor what he gets. We have seen fifty cent cylinder oil

change its name and price simply through a change in the stencil on the head of the barrel. Until some standard analysis as to what shall constitute the various oils used in the engine room—and perhaps not more than four grades will be required—and a bureau for testing the same are established, the consumer of lubricating oil is sure to be imposed upon.

We know of no other article used by the engineer in whose selection he is so practically helpless as in that of his oils. One other point: we have always cherished the theory that oil does not act as a film, but that it distinctly under pressure separates into minute balls, thus giving a rolling ball bearing instead of a sliding film bearing. Perhaps this opens up a new line to work upon and gives food for thought to some of our lubrication "sharps."—Editor.]

LUBRICATION, as it is considered in mechanics, is the application or introduction of a smooth fluid substance, preferably an oil, between two hard moving surfaces that will keep them from coming in direct contact.

Unless the surfaces are kept apart by some medium the asperities and irregularities which exist on all surfaces, no matter how hard or smooth, will interlock, and the friction caused in tearing them apart and wearing them down will generate heat.

The mission of a lubricant is to flow between the close-fitting surfaces filling up the interstices and covering up the high spots, acting as a cushion and taking up whatever heat may be generated and carrying it off, instead of allowing it to be absorbed by the wearing surfaces.

To do this properly a lubricant should have certain properties: it should be of a fluid nature, so that it will flow readily

between surfaces that are close fitting and under heavy pressure.

It should possess a certain amount of cohesiveness, or viscosity, as it is usually called. By cohesiveness is meant the property of a substance to cling to its own particles; viscosity is understood as the degree of fluidity that an oil possesses, or the resistance opposed by its particles to their separation.

A lubricant should have good adhesive properties, so that it will cling well to metallic surfaces. By adhesion is meant the property of a substance to cling to other than its own particles.

It should have sufficient flash test in order that whatever heat it is subjected to will not cause it to give off an inflammable vapor. It should have a cold test of such degree that it will remain fluid at low temperatures.

The above requirements will be found embodied to the greatest degree in the various kinds of petroleum, animal and vegetable oils.

The first oils used in the lubrication of machinery were vegetable oils, such as castor oil, palm oil and olive oil; and animal oils, such as lard, neatsfoot, tallow and sperm oil.

All of these oils, while in many respects excellent lubricants, are not now used to any extent since the introduction of petroleum or mineral oils, for the following reasons: First, on account of their higher price as compared with petroleum oils; second, being of organic origin, they absorb oxygen from the atmosphere, and in time become rancid, thick and gummy. The oils are of very poor cold test, congealing at a comparatively high temperature, thus making them inconvenient for use in cold weather.

In recent years the processes of petroleum or mineral oils have been

brought to such a state of perfection that they have almost entirely displaced animal and vegetable oils as lubricants for machinery.

Petroleum oils have many advantages as lubricants over animal or vegetable oils. First is their cheapness; second, being of non-organic origin, they do not change their condition, do not become rancid, thick or gummy by constant exposure to the air, and have no corrosive action on metals; third, by what is known as fractional distillation they are separated into a great many different grades, from the lightest spindle oils to the dense, heavy cylinder oils; fourth, they are of lower cold test, and there is not the liability of spontaneous combustion that there is in animal oils.

The engineer in charge of a plant will find on the market a great variety of petroleum lubricants to choose from to meet the various conditions which will arise in the proper lubrication of his machinery.

The conditions which produce the greatest difference in ordinary lubrication are: the nature and quality of the lubricant, the nature and condition of the wearing surfaces, the speed and pressure and the temperature.

Variations of friction of lubricated surfaces occur with every change of condition of either the bearing or journal surfaces, or of the lubricant applied to them.

The ordinary facilities of the engine room do not usually afford means to make elaborate tests of the coefficient of friction of various oils, nor would such tests be of any practical value to an engineer, as they can only be made with any degree of accuracy on expensive testing machines built expressly for this purpose, and which are very little used except in the laboratories of the technical schools and the testing rooms of

a few of the large railroad companies and manufacturers of oils.

But an engineer can often make valuable comparative tests of different grades of oil on the ordinary machinery of the engine room. For instance, a difference of several degrees in the temperature of the bearing of an engine or a dynamo may be detected between two oils by means of a thermometer placed in the bearing with the bulb resting on the shaft or immersed in the oil chamber.

In tests of this kind care must be taken that the rate of oil feed, the belt tension, the pressure on the bearings and the speed remain constant, and allowance should also be made for any difference in the temperature of the room during the tests.

Some day engine builders will equip the main bearings of their engines with thermometers so that the temperature can be noted. The engineer will then be able to see at a glance whether the temperature is above the normal or not, in the same way as he notes the temperature of his feed water by means of a thermometer in the boiler feed pipe. Of course, an engine bearing, from lack of oil, stoppage of the oil cups or other causes, can become overheated to such a degree as to ignite the oil in some particular spot before the rise in temperature would be indicated on a thermometer a few inches away.

But a thermometer in a bearing would indicate from day to day any difference in the condition of either the lubricant or the bearing. For instance, an engineer taking up the lost motion of a main bearing notices that the temperature rises 10 or 20 degrees above what it had previously been, and this warns him that this bearing must be carefully watched to see that it does not get too hot.

One of the essential points in lubrication is that the lubricant be capable

of reaching every part of the contact surfaces; and, in connection with lubrication, one might assume an oil to have the nature of a mass of globular molecules or atoms, which roll on each other and the wearing surfaces, and are carried or flow between the close-fitting surfaces and form an elastic coating to the metal. This coating becomes thinner as the pressure increases or the temperature rises, and thicker as the pressure decreases or the temperature falls, absorbing whatever heat there may be generated and carrying it off.

The best lubricant for a bearing under normal conditions may not do so well after heating commences; a thick, viscous oil which, under ordinary conditions on high-speed machinery would be comparatively wasteful of power, is often an excellent lubricant for a hot bearing, and for the following reasons an engineer, on finding a bearing heating up, will supply the ordinary oil freely, and, at the same time, loosen up the bolts so as to allow for increased expansion and free flow of oil. If the heating continues, and the engine or machinery must be kept in operation at all hazards, he will turn to his cylinder oil, apply it freely, and often with good results.

The reason of this is that the cylinder oil, owing to its high fire test, became thin and limpid without burning, and flowed freely between the close-fitting surfaces and at the same time absorbed the heat that would otherwise have gone into the metal and carried it away, while the engine oil, being of lower flash test, vaporized, and, if the bearing got hot enough, caught fire.

The theory of a heating bearing is as follows: If for any reason the oil is prevented from reaching every part of a bearing, the surfaces will come in direct metallic contact, excessive friction is set up and heat is generated; if the pressure

is not great and the bearing area ample, the heat may be absorbed by the metal and radiated out into the air, and nothing serious will occur; but if the pressure is heavy and the speed high, the heat may be generated faster than the metal can carry it away. The original dry spot may not have been over one-eighth or one-fourth of a square inch in area, but sufficient heat may have been generated at this point to cause the adjacent oil to evaporate and shrink away, thus increasing the area of dry surface. As the heat increases the metal expands, causing the surfaces to fit tighter, and thus creating more friction until the temperature reaches such a point that the oil ignites and burns.

To the Editor of "The Electrical Age":

I have just taken charge of a large office building. Among other things which are perhaps serious but do not call for so much direct complaint from the tenants, is the condition of the water supply. The pumps are in first-class condition, and the same is true of all the piping and connections. I have had the supply tank drained and cleaned, and yet the water leaves the faucets in various offices looking like a mild brine when holding it in a glass to the light, and, after a few minutes, it settles. Have any of your readers had this trouble? I would be thankful if some brother engineer could help me out.

ED. RIXON.

To the Editor of "The Electrical Age":

The erecting engineer of one of the large pump manufacturers assured me that a pump would require practically (not theoretically) the same amount of steam, or power, to lift a column of water three feet as it would to lift it 19 feet in height, all conditions being equal and proper, he claiming that to lift

water, say, three feet—or, in fact, any distance above the water level—requires the forming of a vacuum by the pump. Once the vacuum is formed there is no additional work required of the pump. From this statement it would appear that it would cost no more to lift water 19 feet than to lift it one foot. I must admit this is too much for me, and I would ask if any of your readers could throw some light on this question.

JOHN HEWE.

To the Editor of "The Electrical Age":

Apropos of the engineer who is about to take charge of a strange plant, and is not always confident of mastering its details of operation in as short a time as he desires to, a writer in the "National Engineer" gives some sound advice. He states that there are several methods of familiarizing one's self with nearly all kinds and types of apparatus such as come under the supervision of the engineer. First, to carefully read the mechanical papers; second, to visit other plants. In the mechanical papers all topics relating to construction and operation of power and transmitting machinery are treated at length, with drawings and details that all may easily understand. Should the reader be in doubt on any question, he may have it solved by these papers by merely writing them his inquiry. The editors of the mechanical papers have ample facilities for supplying information to engineers, and the opportunity thus afforded should not be neglected.

Visiting other plants has this drawback: that, in some, the visitor will receive little or no enlightenment, because those in charge have not the ability to impart any information. In other cases will be found the ability, but no disposition to exchange opinions. These cases need not discourage any one, as many

other plants are always open for inspection, and information is freely volunteered. There is still another method, and that is by changing positions frequently; but this is hardly recommended, however, as the engineer who is in the habit of changing his position very often will be apt to gain the reputation of a "rolling stone," and, while he may gather a lot of experience, many employers will hesitate to employ him.

In many cases an engineer has been employed for a considerable length of time on a small plant, but, by constant study and observation, he has spent his time to advantage, in order to be prepared for a better situation in the future. The writer cites a case which came under his observation, showing how such preparatory work meets with reward. An engineer formerly operating a modest plant assumed charge of the power department of a large hotel, and speedily demonstrated his ability to operate the installation, with a greater output, and, at the same time, a considerable reduction in the operating expenses. His predecessor was one of the kind who did not believe in telling any one what he knew or "fooling with them humbug papers."

THOMAS HAMPTON.

Notes on Massachusetts License Law

N. Lawrence.

I HAVE read with some interest the personal opinions of some contributors to your esteemed paper regarding Massachusetts license and inspection laws and the men appointed to enforce the same.

Allow me, for the edification of your readers, to give some actual facts in the case. After innumerable patchings, amendments, etc., of the original law, it now reads as follows:

The grades are first, second, third class engineers; hoisting and portable engineer's license is designated a special; first and second class firemen; special licenses, equivalent to any of the above grades and limited to a certain plant, are issued at the request of employer, and generally at a somewhat modified examination. These special licenses are subdivided into two grades—"to take charge of and operate," or "to operate only." The hoisting and portable license, itself a special in its "unlimited" form, is sometimes issued limiting the holder to a particular class of work, or style of machine, or else as a special for a certain plant.

Should estimate the number of "grades" of licenses, all told, to be probably not less than twenty-five, not counting the two grades of first-class fireman's license, one to "operate only," which is issued nowadays, and one "to take charge and operate," which was issued some years ago, and can be renewed in that form if the applicant knows enough to insist upon it.

Above remarkable combination works in this manner: The first-class "unlimited" can take charge of and operate any steam plant whatsoever, including hoisting and portable and fire engines.

The second-class man has about the same rights, with the exception that the engine, or engines, must separately figure not more than 150 horse power. Sec. 6 of Act of 1899: "The engine power shall be reckoned upon a basis of a mean effective pressure of 40 pounds per square inch of piston for a simple engine; 50 pounds for a condensing engine, and 70 pounds for a compound engine, reckoned upon area of high-pressure piston," which formula should be elastic enough to suit anybody.

The third-class man can take charge of and operate one boiler and engine,

or engines, which must separately figure not more than 50 horse power. He may take charge of and fire one boiler, whether 10 or 1,000 horse power, but not two 10 horse power, nor two low-pressure boilers, nor can he act as fireman on two or more boilers without exchanging his license for a first-class fireman's, or, in case of two or more low-pressure boilers, for a second-class fireman's license.

The hoisting and portable man can do just what his license states, but may at times be superseded by a man holding first, second or third engineer's license, at the pleasure of his employer.

The first-class fireman, as now issued, is limited to operate high-pressure boiler, or boilers, only under an engineer. He cannot take charge of nor operate low-pressure boiler, or boilers.

The second-class fireman can "take charge of and operate" low-pressure (not over 25 pounds) boilers only. He cannot take charge of nor operate high-pressure boiler, or boilers.

Locomotives, steam rollers, automobiles, boilers in private residences, boilers in apartment houses of less than five flats, boilers under the jurisdiction of the United States, boilers used for agricultural purposes exclusively, boilers of less than eight horse power and heating boilers provided with an approved make of pop safety valve, set to blow off at 15 pounds of pressure to the square inch, are exempt from inspection, and can be run by unlicensed men. All boilers, with above exceptions and that are not insured by approved insurance company, shall be attended to by the State inspectors.

As for figuring horse power of boilers, Sec. 6, Act of 1899, states: "The horse power of any boiler shall be ascertained upon the basis of three horse power for each square foot of grate sur-

face for a power boiler, and on the basis of one and one-half horse power for each square foot of grate surface if the boiler is used for heating purposes exclusively."

The above is the law to the letter. The Attorney-General of Massachusetts gave a decision some time ago that, if there was one license hung up in an engine room covering the capacity of the plant, the owner could at his discretion use unlicensed men. Some of the largest plants of the State are taking advantage of this decision.

As the Massachusetts Legislature, in its wisdom, did not appoint a professional engineer as chief for the department, the chief of the Massachusetts District Police, who has his hands full of other matters, and besides never claimed to know an engine from a hole in the ground, acts as chief, and, consequently, each and every one of the ten examiners at the time of an inspection or examination interprets the law according to his own personal ideas, knowing that he is practically irresponsible for his acts. There being ten examiners, there are ten different examinations, more or less severe, according to the examiner and the part of the State where the applicant happens to reside at the time. The law does not designate the length of time necessary to become a resident of any particular place. Applicant dissatisfied with action of any examiner has the right to appeal to the Board of Appeal, consisting of the remaining examiners, the decision of a majority of said board to be final.

As to the financial part, the Massachusetts District Police report for 1901 shows expenses for inspecting and examining department, about \$22,000; income from engineers examined and boilers inspected, about \$13,000; deficit to the State, approximately, \$9,000. The

work done by each inspector or examiner, according to the same report, averages two engineers examined and one boiler inspected per day, counting 300 working days per year.

The average wages of engineers and firemen at present are: First-class engineers: chiefs, \$18 to \$21; assistants, \$15 to \$17; second-class engineers, \$14 to \$16; third-class engineers, \$10 to \$13; hoisting and portable engineers, \$15 permanent or \$17.50 intermittent work. First-class firemen, \$11 to \$14; second-class firemen or janitor, \$20 to \$60 and "found" per month, with a tendency of decreasing all around, probably owing to the "overproduction" of "engineers and firemen."

The relative value of the licenses are as follows: First-class engineer, second-class engineer, second-class fireman, hoisting and portable engineer, first-class fireman, third-class engineer.

Having so far given actual facts, easily proven, allow me to make some pertinent remarks and questions. Is there any reason why a license for stationary engineers should not be formed upon the same lines as the United States Marine Law, which provides for a certain amount of actual experience before passing to the next grade, thereby decreasing the great number of so-called engineers and firemen running around with a license obtained by hook or crook, possibly through the aid of our alleged "engineering schools," each and all claiming by advertising in daily papers, or otherwise, to be "in with" the examiners?

Considering that we have now in our State of Massachusetts about five men to each job, and more to come, would it not be sensible and advisable to simply have an examining board located in the city of Boston, consisting of, say, five examiners, who should be instructed to

pay more attention to a man's actual experience than to his ability of giving stereotyped answers suitable to any individual examiner's personal ideas on engineering questions, on which the foremost authorities and engine builders in this or other countries do not agree?

Is there any reason why an examiner, after granting a man a certain license, thereby declaring him a capable, trustworthy man, should spend the State's time and money by constituting himself a supervising engineer over said man, who may possibly successfully manage a plant that the examiner could not keep going one day?

Why is it that the lives of people living in houses of five flats or over are more precious than of people residing in a house of five flats or less, where no license is required? It is also comforting to know that an eight (or less) horse-power boiler does not require either inspection or a licensed attendant. We had one such boiler explode right in this city some three years ago, killing one man, the record of which is on file in the daily papers, but not in the Annual District Police Report.

We do not worry over our inspectors being worked to death inspecting boilers or otherwise. "None of them die and none resign," unless required to do so, which has happened more than once.

I have here related things as they are, without any personal prejudice whatever, and would end up by stating that the opinion of 99 out of 100 engineers, including the most earnest and persistent workers in behalf of the license law, is that the license and inspecting laws of the State of Massachusetts, in their present form, have benefited no one outside of the insurance companies, the examiners themselves, and, to a certain extent, the firemen.—*Power.*



Current Engineering and Scientific Notes

Abstracts from the Foreign Papers



Transmitting Pictures by Electricity.

(Elektrotechnischer Anzeiger.)

Herr von St. Schneider is the originator of a new system for the electrical transmission of pictures. His system makes use of the Pollak-Virag rapid telegraph recorder and a selenium cell for effecting the necessary variations in intensity of illuminations. At each station two telephone receivers are connected to a small mirror so as to vibrate this in two directions. Corresponding telephone receivers are connected together, and within each circuit is placed a revolving contact maker. One of these contact makers makes and breaks the circuit a certain number of times for each revolution, and this, of course, sets up corresponding vibrations of the two telephone receivers in that line. The other breaker does not actually break the circuit, but introduces a gradually increasing resistance, starting at zero and rising to a maximum, and then dropping to zero again. The effect of this is to produce a comparatively slow motion of the two telephone diaphragms connected in that circuit. When these two contact makers, which are connected to the same shaft, are revolved, a beam of light, reflected from a suitable source upon a screen, will travel gradually over the entire screen; starting at one end, working its way back and forth to the other, and then jumping to the first point again. The method of transmitting is this: A beam of light from an arc lamp is al-

lowed to fall on the mirror at the sending station. By a suitable grouping of lenses, the beam is thrown horizontally through a photographic negative, and is then focused on a selenium cell. The effect of this will be to vary the current in the circuit containing this cell, corresponding to the intensity of the light falling upon it. The circuit from this cell is carried to the receiving station, and there the current is superimposed upon the current flowing through an electric arc. One ray from this arc is thrown upon the receiving mirror. The intensity of this ray varies with that falling upon the selenium cell; and since the ray traces a path on a receiving screen similar to that which the sending ray follows, the result is a production of a copy of the photograph at the receiving station. It is, of course, necessary that the image be repeated at least ten times a second to give a constant effect upon the retina.

Electric Arcs Between Metal Electrodes.

(Archives des Sciences Physique.)

An account of some experiments made by Messrs. Guye and Monasch in connection with low intensity arcs between metal electrodes. The experiments were made in air; the authors contemplate simplifying the conditions of the problem by working with simple gases and direct current. Using copper electrodes and a current maintained constant at

from 0.041 to 0.053 amperes, the consumption of power is practically proportional to the distance apart of the electrodes, at least between 3 and 10 mm. On progressively diminishing the distance while the current is maintained constant, for all the metals investigated, excluding iron, a critical point is found to exist, from which the arc will undergo a noticeable change, hissing and changing color, i. e., taking a bright blue tint. If the distance of the electrodes be further diminished from this transition point, the pressure necessary to maintain the same current will increase up to a certain point, from which it begins to decrease, until it becomes zero on the electrodes coming into contact. The phenomenon seems to be the more noticeable as the metals are better conductors; it is specially marked with silver and copper, less with gold and platinum, scarcely visible with nickel, and not at all visible with iron, at least, so far as the currents used are concerned. This change in the arc at a critical distance is likely to be a complex phenomenon, most probably connected with the singing-arc phenomenon, where the gaseous medium plays a prominent part, and possibly with the transformation of the arc in an oscillating discharge, because of the diminution of resistance due to the presence of conducting metal vapors.

Musical Sounds from Vacuum Tubes and Flames.

(Revue des Sciences.)

Following up the experiments of Mr. Duddell on the singing arc, Prof. A. Righi, of Rome, has succeeded in obtaining musical sounds from vacuum tubes. A tube with aluminum electrodes, at a distance apart of 0.05 mm. for a rarefaction of 1 cm. of mercury, is connected through a high resistance with a battery

of 800 volts, a current of a few milli-amperes being allowed to flow. The tube is shunted by a condenser and a telephone in series. Musical sounds are given out, and the pitch can be raised by reducing the added resistance, the capacity of the condenser, the distance between the electrodes, or the pressure of the air in the tube; increasing the voltage has a similar effect. Instead of a vacuum tube the flame of a Bunsen burner may be used, and in some cases the best results are obtained when the flame is rendered a better conductor by volatilizing common salt on the electrodes.

A Rival for the Edison Storage Battery.

(London Electrical Review.)

Jungner's search for an accumulator which would avoid the difficulties of acid lead cells became successful in 1897-1899, and in the last-named year he patented an accumulator using a potash solution as the electrolyte, and plates of powdered metal or oxides of such metals as were insoluble in the liquid and gave sufficient electromotive force. His later patents have been on improvements in details only. The oxides first specified were those of cadmium, copper, iron, manganese, silver and nickel. His patents were bought by a Scandinavian company in 1900, and some months later an automobile furnished with these cells was tried under official conditions. The total weight of this, including batteries and passengers, was 1,162 pounds. The battery itself weighed 638 pounds. On wet and muddy roads about 87 miles were covered with one charge. A final test, made on the streets of Stockholm, resulted in a run of 92 miles on one charge, the potential of the cells not falling below the nominal; and at the

end of the run the carriage was traveling at a speed of $16\frac{1}{2}$ miles per hour. The battery used for these tests contained electrodes of powdered oxides of nickel and silver, separated by asbestos paper. The latter was found to need renewal after every 120 charges, and the metals were too expensive. Jungner therefore returned to nickel peroxide as the positive, and powdered iron as the negative. This was done in the fall of 1900, and it is claimed to give priority over Edison's patent of February 5, 1901.

An English View of American Roads.

BY instruction of the president of the Board of Trade Colonel Yorke, Chief Government Inspector of British Railways, paid a visit to this country last autumn, and his report has just appeared in a recently issued blue book. Colonel Yorke mainly directed his attention to the developments of the facilities for transportation, and he has returned home enthusiastic in praise of the interurban railways which are now such a prominent feature of the United States. He points out that the electrical interurban systems of England are nothing more than tramways, and quite unsuitable to high speeds. If lines of this nature are to be as successful as they are in America, Colonel Yorke says, the owners must profit by American experience and follow American methods. Colonel Yorke anticipates that the New York subway will prove a disappointment, although it will increase the facilities for travel between the outskirts of the city and the business center. He thinks it will not do much to relieve the congestion of traffic in the streets. It will mitigate the undue crowding of cars on the tramways and elevated rail-

way, but, he says, it will not reduce the number of vehicles on the streets, as there are practically no omnibuses and very few cabs to be affected by it. Colonel Yorke remarks that in London the case would be different, as the construction of a subway or tube would surely cause a diminution in the number of 'buses plying along the same route. This is a curious conclusion, as Colonel Yorke must know that since the construction of the city and South London tube the number of competing 'buses has increased 25 per cent.

Colonel Yorke admits that England can never hope to equal America in the size of steam engines or cars. American automatic coupling mechanism he finds still far from perfect, as well as the American air-brake system as applied to a freight train, for which much has been claimed. "It may be questioned," writes Colonel Yorke, "whether the economies claimed for the American methods are as great as is sometimes hastily assumed." He thinks, however, that English companies would get far more out of their personnel by following the American plan of picking their men for physique and ability to start with, and by giving every man a chance of rising to the top by means of periodical examinations for promotion.

The American system of automatic signaling he considers by no means perfect, and, so far, not ready for application to English main lines. It is merely a labor-saving device, and does not of itself introduce greater safety of operation. In fact, it is upon this point of safety that England is conspicuously ahead of the United States, especially in her better application of the block system and in the matter of permanent way construction. Each might well take points from the other.



With Our Foreign Consuls



American Automobiles in Malta.—United States Consul Grant writes from Valletta, Malta:

I have recently received applications from parties here for information with regard to the advantages of the American automobile. There are already several in use, and correspondence is now being carried on between probable purchasers and American makers. One gentleman recently went to England, and, after looking at the various makes of machines there, ordered one of American origin, which is giving good satisfaction. This machine is of the steam variety, being the only one of its kind here. The others are operated by gasoline. One firm desires to secure large vans for delivery of goods. No fault is found with gasoline machines, except that it is somewhat difficult at times to procure gasoline, on account of local laws. It is imported from New York and other places, but the supply is apt to be limited.

American manufacturers of automobiles should bear in mind that Malta does not possess, as a rule, long, level stretches of road. There are many steep hills, some of them having a grade of 1 in 9. The machine should be much more powerful than is the rule in the United States. Another thing to be remembered is that, in giving price, the manufacturer must quote f. o. b. New York, otherwise the inquirer will not know what his machine is going to cost him. People here know nothing about

distances or freight rates between ports of shipment and our interior cities. Several negotiations have failed because the dealer in the United States insisted upon quoting prices f. o. b. Chicago or other place of export. When possible, it is even better to give prices c. i. f. Malta. In other words, when the buyer at Malta writes for terms, he should be given information which will enable him to figure exactly what the machine will cost him, landed here. If information as to cubic measurement of the machine as crated or boxed for shipment can be given, it will add to the satisfaction of the buyer. Some time ago an American carriage manufactured in one of our interior cities was sold here, and, to my own knowledge, one of the greatest points considered was the completeness of the information given in the catalogue. I provided other catalogues, which were prepared in attractive style and showed desirable goods, but information as to terms, etc., was very meager, and they were not considered. It must be remembered that transportation from New York to Malta is now ample by way of a direct line of steamers. My assortment of automobile catalogues is somewhat limited, and I should be pleased to receive such as manufacturers may see fit to send me.

Steel Industry in Ontario.—Consul E. N. Gunsaulus writes from Toronto: According to reports of the Bureau of Mines the steel industry in Ontario

shows a large gain over last year, the output having been 68,802 tons, valued at \$1,610,031, compared with 14,471 tons, valued at \$347,280 in 1901. The difference was largely due to the entry of the Sault Ste. Marie works into the field. The production of pig iron was 112,687 tons, valued at \$1,683,051, compared with 116,370 tons, worth \$1,701,703 in 1901. The wages paid in the pig iron and steel industry amounted to \$510,107, compared with \$274,554 in the year previous. The production of iron ore amounted to 361,472 tons, worth \$521,409, compared with 273,530 tons, valued at \$174,428 in the previous year. In this work the wages paid amounted to \$228,534, compared with \$231,039.

Vulcanized Timber in England.—

The following extract from the Liverpool "Daily Post" has been received from Consul James Boyle, of Liverpool:

A considerable amount of interest has been aroused by the announcement, as the result of a prolonged series of experiments, of a method of so treating timber as to secure even from soft wood a largely increased toughness and hardness. The process is described as one of vulcanizing, comparable in some respects with Bessemer's process of converting iron into steel, and is the invention of Mr. Powell, a Liverpool merchant. The treatment to which the timber is subjected is, roughly speaking, that of saturation at boiling point with a solution of sugar, the water being afterward evaporated at a high temperature. The result is to leave the pores and interstices of the wood filled in with solid matter, and the timber vulcanized, preserved and seasoned. The nature of moderately soft wood, it is claimed, is in this way changed to a tough and hard

substance, without brittleness, and also without any tendency to split or crack. It is also rendered remarkably impervious to water. Hard woods similarly treated derive similar benefits. Moreover, it is claimed that the process may be completed and timber turned out ready for use in a few days. The invention, which has been patented, is to be brought before the attention of the timber trade by a series of practical demonstrations and lectures. It is stated that inquiries from Russia and other foreign countries have already been received.

Niagara Falls Power for Toronto.—

Consul E. N. Gunsaulus, of Toronto, says that a recent issue of the "Canadian Manufacturer," of that city, contained the following:

The new Niagara Falls Power Company, which will be financed largely by Toronto capital, will commence operations immediately after the Government agrees to give it the right to develop power. The electricity will be brought to the city by cable over the entire distance of 90 miles, and it is expected that at least 125,000 horse power will be generated when the plant is working to its full capacity. For use within the city 20,000 horse power will be produced at first, but the company intends to sell power to municipalities and firms along the line. The power will be used to operate the Toronto street railway and the electric light company's plant. It is expected that the expenditure will total about \$5,000,000, and the work will be completed within two years or less.

It is proposed, the Consul notes, to convey the power to Toronto by means of a double-pole line.



Digest

Engineering Literature of the Month



Spongy Antimony for Storage Batteries

(*Western Electrician.*)

AMONG the recent French patents is one which has been granted to Mathias for improvements in accumulators. The original feature of the process is the substitution of spongy antimony for forming the negative electrodes. This results in reducing the weight of the electrode by 60 per cent. The spongy antimony is obtained in the following way: With the oxychlorides of antimony and water a paste is formed, into which is incorporated a solution of rubber in benzine. The holes in the lead grid are filled with this paste, care being taken to compress the substance so as to expel the excess of water. It is then dried in an oven at a temperature of 50 degrees C., when the mass becomes porous. To form the plate thus prepared it is necessary to reduce the antimony compound. For this purpose the plate is immersed in an electrolyte formed of sulphuric acid diluted to 10 per cent. It is placed opposite a carbon plate of the same surface, forming the positive electrode, and the two are connected by a wire. The hydrogen resulting from the decomposition of the water acts upon the oxychloride of antimony to combine with the chlorine, forming hydrochloric acid, and with the oxygen to form water. The antimony is thus reduced, and the formation of the plate is complete when no more hydrogen is given off. The plate, after being washed and dried, is ready to receive its charge in the pres-

ence of a positive plate. The spongy antimony can also be prepared in the form of powder by reducing a concentrated solution of antimony chloride by zinc or iron scrap. The powder thus formed is washed into a paste, which is pressed into the holes of the grid. The electro-motive force of an element using negative plates prepared in this way is stated to be as high as in the usual form.

Hooded Third Rail.

(*Electrical World and Engineer.*)

In a description of the interurban electric system of the Wilkesbarre & Hazleton Railroad mention is made of the hooded third rail which is used in this installation.

The contact rail is a notable departure from common practice up to the present time, as it is protected from sleet and snow by a 2 x 6-inch pine plank held directly over the rail. Already this protection has demonstrated its usefulness, for during the severe sleet and snow storms of December the cars operated with perfect ease. The added element of personal safety is also a very great factor. This guard plank is supported by oak posts spaced every eight feet, and both guard and rail are carried by unglazed vitrified clay insulators, furnished by the Ohio Brass Company, and spaced every 10 feet. To prevent creeping the fish-plates are left moderately loose, and an anchoring insulator is placed in each rail midway between joints. The contact rails are 60 feet

long, and weigh 80 pounds to the yard. They are of special composition, embodying high conductivity. Both contact rails and track rails are bonded with Chase-Shawmut soldered bonds. The bonds have been applied for over six months, and the great shock due to heavy steam locomotives and freight cars passing over the line during the entire construction period has not produced thus far the least indication of breaking away.

The application of the soldered bond necessarily involved a departure from the usual method employed in laying track where protected bonds are used. The bond is under the foot of the rail, and, to facilitate the work, it became necessary to turn the rail bottom side up. As the track men had only spiked the rails center and joints, this was easily done by drawing the inside spikes for a length of about 20 rails, depending on the local degree of curvature in the track. The joints were then surfaced, bond applied, and eight men with a few short bars could return the rail to its normal position. The spikers in this work followed the bonders rather than the rail men, thus avoiding delay and keeping the spikers busy.

The Mechanical Equivalent of Heat.

(Journal of the Franklin Institute.)

Carl Hering states that the best and most authoritative summaries of the numerous experimental determinations of this constant are unquestionably those contained in two reports to the International Physical Congress of 1900, which met in Paris. One of these is on the mechanical equivalent of heat, by Prof. J. S. Ames, of Johns Hopkins University, and the other on the specific heat of water, by Prof. E. H. Griffiths, of Cambridge, England. The specific heat of water and the mechanical equivalent of heat are the same constant in

different terms, the former being merely the value of the latter in absolute units.

These two summaries are authoritative, and, to some extent, official, as they are in the form of reports to an international congress. That congress took no action toward adopting any definite value; but a value approximating much more closely to the most probable one than the one in general use does is easily obtained from these reports.

Griffiths, in his report, after a careful comparison of the best determinations, recommends the number 4.187 joules of what is usually termed the specific heat of one gram of water raised from 15 to 16 degrees C., measured on the hydrogen scale of the International Bureau. The probable error is less than one in 2,000. This change in temperature is to be considered the same as the mean value between one degree and 100 degrees C.

This value, 4.187, agrees with the one recommended in the report of Ames.

Taking for the value of gravity at sea level and at 45 degrees latitude, as 980.5966 meters—a standard value given by Helmert and used by our Coast Survey—the value of the mechanical equivalent reduces to 426.985 kilogrammeters. Some recent very carefully made researches by Barnes, which were not finished in time to be included in Griffiths's report, give the value 426.6. The allowable error in Griffiths's value affects the fourth figure, and it is, therefore, hardly justified to retain more than four figures; but, in view of Barnes's more recent determination, it would probably be more correct to abbreviate Griffiths's value to 426.9 instead of 427.0.

This value, 426.9 kilogrammeters per kilogram, centigrade heat unit, corresponds to 778.1 foot-pounds per pound, Fahrenheit heat unit, which two values may, it seems, be accepted as the best determinations known to-day.

Locomotives Wearing Out Quicker than New Ones Can Be Supplied.

(Manufacturers' Record.)

Within the last four years the demand upon the locomotive capacity of the railroads of the country has increased at such an astounding rate that engines cannot be kept off the road long enough for proper repairs, and the number of engines thrown into the scrap heap or consumed in service will increase greatly beyond the capacity of the builders to supply their places.

Notwithstanding the large increase in locomotive building, every locomotive builder in the country is rushed with orders. It is estimated by a gentleman connected with one of the largest locomotive works in the country that the total number of engines built in the United States during 1902 was 3,900, or 13 engines for each working day. In 1901 the output was 3,384, and 337 of that number were for export.

Electrical Course at Union College.

(Concordiensis.)

Mr. C. P. Steinmetz, chief electrical engineer of the General Electric Company, gives an account of the electrical engineering course, of which he is the director, at Union College, Schenectady, N. Y. He states that he accepted the appointment on account of the extremely favorable circumstances, due not only to the reputation of the college, but also to its close proximity to the largest electrical manufacturing company in the country, which gives the students chances to see and familiarize themselves with apparatus, and receive information which no other engineering school could offer.

The first two years of the courses are essentially devoted to general culture

studies, as languages, literature, logic and composition, history of man and natural history, biology, etc. Only such general engineering studies as mathematics and mechanics, which must be familiar before engineering work can be undertaken, are included in the first two years.

The last two years are devoted essentially to special engineering studies. The foundation of electrical engineering is mechanical engineering, and, while a young electrical engineer cannot be expected to be fully familiar with all branches of electrical engineering, he must be familiar with the fundamental principles of mechanical engineering. Hence, the junior year will be largely devoted to mechanical engineering, as experimental and theoretical mechanics, hydraulics and hydraulic machinery, as turbines and their design, steam machinery, as steam engines and their design, locomotives, gas engines and thermodynamics. The senior year and a part of the junior year will be devoted to electrical engineering.

A post-graduate course in electrical engineering has been established, which, when completely organized, will give advanced instructions, comprising many subjects which, while of fundamental importance in the modern development of electrical engineering, are not taught by any college, hardly not even published yet. It is such knowledge which establishes engineering reputations. It is not sufficient for an electrical engineer who desires to reach high positions to be able to solve 99 out of 100 problems which he meets in practice, but it is the solution of the one hundredth problem, where everybody else fails, which establishes the reputation of the engineer and raises him to positions where he can leave the solution of the other 99 problems to his subordinates.

Commissioner Monroe's Letter Suggesting a Municipal Lighting Plant for the City of New York.

DEPARTMENT OF WATER SUPPLY, GAS AND ELECTRICITY.

Commissioner's Office, 13-21 Park Row.
Robert Grier Monroe, Commissioner.
City of New York, March 12, 1903.

Hon. Seth Low, Mayor of the City of New York and
Chairman of the Board of Estimate and Apportionment, City Hall:

Sir—I herewith transmit a summary of bids received for public lighting for the current year with corresponding prices for the year 1902. I also forward a report from Mr. Charles F. Lacombe, Engineer of Surface Construction, which report contains a statement of prices paid in other cities for gas and electric lighting, with charts clearly indicating the comparative cost, from which it appears that New York is paying far more in proportion than any other municipality.

The proposals issued to all bidders for this year contain the following paragraph:

"20. The Commissioner reserves the right to reject any or all bids or estimates if the Board of Estimate and Apportionment shall determine it for the public interest of the city so to do."

I am unwilling to execute the contracts upon the bids submitted and I recommend in the interest of the public that all bids be rejected.

Section 530 of the Charter directs that

such contracts shall be made after public bidding, and for a term of not exceeding one year. That section is taken from Section 537 (Chapter 378) of the Charter of 1897, and must have been drawn originally to meet then existing conditions, and with the expectation of securing actual competition in the prices between rival companies operating in the same field. Within the past five years the lighting interests in this city have all practically united, and even in those boroughs where there has been no formal consolidation, the territory has been apportioned. In the Borough of Manhattan both illuminants have been absorbed by a single corporation, and there is no rivalry even between producers of gas and producers of electricity. The Consolidated Gas Company of New York controls all the gas and electric light facilities in the Borough of Manhattan, as well as all gas and electric light facilities in the more important sections of the Borough of The Bronx. As far as gas light is concerned, not only does the price remain fixed, but all improvements in the utilization of gas is retarded.

A wide extension of street lamps provided with incandescent mantles is greatly needed. By this method the

same consumption of gas produces three times the illumination given by the open burner. It costs Chicago \$2.40 a year additional for a lamp with an incandescent mantle. It costs the Borough of Manhattan \$11.50 additional, and for the same improvement we must pay \$15 a year in Brooklyn. The Consolidated Gas Company agrees to furnish the ordinary street lamp with open gas burner at \$17.50 per year, and its bid for gas lamps with mantles is \$29 per lamp per year. Neither the Standard Gas Light Company nor the New Amsterdam Gas Light Company (both controlled by the Consolidated Gas Company) bids for incandescent gas lights. Both agree to furnish the ordinary gas lights for much less than \$17.50; the Standard for \$13.-04 1-3 per lamp per year, and the New Amsterdam for \$12.

Their bids are for such lights as are or may be on the line or lines of their mains. These comparatively low bids are induced by restrictions in their charters; but the city is virtually prevented from getting the benefit of these lower bids as far as incandescent or mantle lights are concerned. If it is desired to substitute on a Standard or New Amsterdam lamp an incandescent burner for the ordinary open burner, it is necessary to transfer the lamp from the mains, or to speak more accurately from the books, of one of those companies to the books of the Consolidated Gas Company, paying, of course, the latter company's price.

On the Chicago basis of prices we could save enough on the 5,500 high priced Welsbach lamps in use in Manhattan and The Bronx to change 20,000 ineffective open-flame burners to incandescent mantle lights, improving the illumination of our poorly lit streets in those boroughs 100 per cent. and saving \$40,000 of the present appropriation.

In The Bronx the Central Union Gas Company (controlled by the Consolidated Gas Company) bids \$22 for the open-flame lamp; the Northern Union Gas Company (controlled by the Consolidated Gas Company) and the Westchester Lighting Company (controlled by the United Gas Improvement Company of Philadelphia), each bids \$24, but each of these three bids covers a distinct and separate district. These exorbitant prices, so nearly alike, present an analogous situation to that which existed in 1876 when Hon. William C. Whitney, then Corporation Counsel, advised the Mayor that there was conclusive evidence of collusion, and when as a result of the rejection of all bids a subsequent agreement was made by the same companies as had previously bid to supply the city at greatly reduced rates. The Bronx Gas & Electric Company puts in no bids for gas lights, and finds itself with no opposing bids for electric lights in the section it covers. An analysis of the bids in other boroughs does not show any keener competition. No independent gas company in any district has bid against another independent gas company; no independent electric light company has bid against another independent electric light company. In the entire five boroughs there have been no opposing bidders for supplying the same class of light to the same district—unless we may consider the Welsbach Company, which has put in a bid, but higher than that of the Consolidated Gas Company, for its own "Welsbach" mantle lights.

In 1865 the courts held that the provision of law requiring that contracts for work or supplies must after presentation of sealed bids be given to the lowest bidder was not applicable to the Harlem Gas Light Company, because it had a monopoly. Judge Monell said (3 Rob., at pp. 121-2):

"It is not perhaps too much to say that in every species of work or supplies which can be competed for it is the duty of the corporation to invite proposals, and to give the contract to the lowest bidder. But where there is no possibility of competition, and in respect to whose manufacture one company has the complete monopoly, it seems to me that the provisions of the Charter cannot be deemed to apply, and therefore impose no duty. The law must have a reasonable construction. If the object in a given case fails of accomplishment, the law construed by its intention must also fail. To advertise for proposals for a supply of gas in a district exclusively occupied by one gas company, would be a practical absurdity. It would enable that company to propose for the supply at a price much beyond the fair value; and its single bid (under the Charter of 1861) would entitle it to the contract at the price named, thus defeating the end designed, to secure the city from favoritism and jobbing.

"It is not necessary to deny that illuminating gas comes under the denomination of supplies; but the word in its application to the subject of contracts must be restricted in its signification and meaning to supplies which are, or may be the subject of a general competition, and which can be furnished by more than one person or company. Any other meaning given to the word would impute to the legislature the design of scheming with contractors to defraud the corporation rather than an intention to protect its public treasury."

Judge Porter said (33 N. Y., at pp. 324-5):

"In the present case, an adoption of the construction claimed by the municipal authorities would lead to the absurd conclusion, that the legislature designed to force a provision into the City Char-

ter, compelling the corporation to pay whatever price the sole bidder might choose to exact in his sealed proposals, for the use of property in which he has an absolute monopoly, and in relation to which there can be no competition within the range of legal possibility."

Moreover, in my opinion the provisions of Section 530 of the Charter are too inelastic to permit the city being effectively benefited by competition, were actual competitors in the field. The term of one year is also too short a period for an advantageous contract.

I, therefore, recommend that Section 530 of the Charter be so amended that the Commissioner of Water Supply, Gas and Electricity may make such contracts without public bidding and for a term of not exceeding three years when authorized by the Board of Estimate and Apportionment. If these amendments be passed the Board of Estimate and Apportionment can consider all questions relating to the cost of manufacture and distribution of the supplies under consideration, and contracts fair to both parties can be entered into.

The appropriation for all public lighting for this year, 1903, is \$3,306,346.23. The corresponding appropriation in 1898, the first year of Greater New York's existence, amounted to \$2,570,001.88. The increase in five years has been \$736,344.35, or between 28 and 29 per cent. Notwithstanding this increase, the sum appropriated this year, in view of the prices asked, is entirely inadequate to meet the reasonable requirements of the city. There can be little improvement in the densely populated sections which are now insufficiently lighted, and large areas which have recently been improved must for the time being be left without any lights at all.

The growth of the city, the many public improvements which are now under

way—as, for example, the new bridges which are rapidly nearing completion—all mean a great increase of public lighting; and unless there is a material reduction in prices, the annual appropriation five years hence must necessarily equal or exceed \$5,000,000.

I have called your attention to the fact that the mantle or incandescent gas light is a great improvement over the old open burner. Electricity is the illuminant, however, of the greatest importance for public lighting. Sixty per cent. of our entire appropriation for this year, or about \$2,000,000, will be expended for electric lights.

In the Borough of Manhattan the price bid for a 2000 candle power lamp is \$146. The price in Brooklyn for a 1200 candle power lamp is \$124.50. I have secured from 68 cities throughout the country the prices paid to the various electric light companies for supplying these cities with 2000 candle power lamps, and the average price is \$88.60. In 23 other cities using 1200 candle power lamps the average price is \$81.08. The combination which now imposes exorbitant prices upon New York is formidable, but to my mind its strength is more apparent than real.

The capitalization of the electric light companies in our city may be best exemplified by the New York Edison Company. It is now capitalized at \$45,200,000 in stock, subject to \$40,138,000 bonds, making the total \$85,338,000. The original company, the Edison Electric Illuminating Company, which seems to have had a fairly conservative management and capitalization (\$9,200,000 stock subject to \$6,500,000 bonds), was bought by a syndicate early in 1899. This syndicate at the same time bought the bonds and stock of certain comparatively small companies, and then turned the whole over to the newly formed New

York Gas & Electric Light, Heat & Power Company for \$28,500,000 bonds of that company and \$36,000,000 stock. Shortly thereafter the illuminating and power companies consolidated with each other by adding the \$9,200,000 of Illuminating Company stock to the \$36,000,000 Power Company stock, and forming the present New York Edison Company. The original nominal capital which was increased to the present figures by this legerdemon was as follows:

Edison Electric Illuminat- ing Co.....	bonds	\$6,500,000
Edison Electric Illuminat- ing Co.....	stock	9,200,000
Mt. Morris Elec. Light Co.....	bonds	988,000
" " " " " "	stock	1,500,000
North River Electric Light & Power Co.....	bonds	104,000
North River Electric Light & Power Co.....	stock	400,000
New York Light, Heat & Power Co.....	bonds	320,000
New York Light, Heat & Power Co.....	stock	375,000
Borough of Manhattan Electric Co.....	stock	100,000
Manhattan Lighting Co.....	bonds	250,000
" " " " " "	stock	250,000
Block Lighting & Power Co., No. 1.....	stock	98,000
* Yonkers Electric Light & Power Co.....	bonds	200,000
Yonkers Electric Light & Power Co.....	stock	190,100
* Consolidated Telegraph & Electric Subway Co.....	bonds	4,225,000
Consolidated Telegraph & Electric Subway Co.....	stock	1,514,000
Cash contributed by Power Co. from proceeds of mortgage		4,000,000
Total.....		<u>\$30,214,100</u>

An analysis of the figures in this table will show, however, that they are altogether too high, and that the original nominal capital was itself very much inflated. The figures given for the Edison Electric Illuminating Company are

—
* There is a minority interest of \$9,900 Yonkers stock and \$359,000 Consolidated Subway stock outstanding.

probably not far out of the way. No account is taken of the very great depreciation in the values upon which the capitalization had been originally based (particularly by reason of the abandonment of a number of stations), but on the other hand this was probably offset by a surplus reported to the stockholders of about \$2,800,000 at the time of the consolidation. The Mt. Morris Company, however, was barely earning the interest on its bonds, so that its stock was probably practically worthless; the Borough of Manhattan Company was an operating concern with no plant of its own; the plants of the Manhattan Lighting Company and the Block Company had been abandoned; while the bonds of the Consolidated Subway Company had been issued at a considerable discount, and its stock, as I am informed, either without consideration or in consideration of patent rights now of no value.

This enormous valuation is based upon the profit permitted by the present monopoly system. Modern improvements, especially in the concentration of the work of producing power (which, incidentally, as above stated, caused the abandonment of so much of the original plant of the company) have so rapidly decreased the expense that while the cost to the company per kilowatt hour of current delivered is known to have been over 5 cents in 1900 and about $4\frac{1}{2}$ cents in 1901, there is good reason to believe that it has since been reduced to about 3 cents. I do not find, however, that there has been a corresponding reduction in prices. The bills presented to the Department for lighting public buildings for January, 1903, show that the city is charged upon an average at the rate of 15.100 cents per kilowatt hour.

There can be no question but that the capitalization of the Edison Company

represents several times the value of its plan. If the City of New York would undertake to supply itself with electric light, its interest charges would be limited to the amount actually expended on its plant and it would not be burdened with the necessity of declaring dividends on watered stock. In the Borough of Manhattan the electrical conductors would be carried through the existing subways without incurring any expense by way of rental for the space occupied. These subways are divided in ownership between two subway companies, but each of them is bound by its franchises to "without charge supply to the City of New York all space in said subway necessary for its electrical conductors and the electrical conductors of each separate department of said city which may now or hereafter be required."

I am informed by officers of the Edison Company that the subway rentals for electrical conductors which are now used for city lights, amount to a hundred thousand dollars a year. If the city had an electric light plant the cost of distribution would be reduced by that amount.

The total cost to the New York Edison Company for generating and distributing electrical energy is as I have stated probably less than three cents per kilowatt hour for energy delivered at the lamp terminal. A pair of lamps such as are used on Fifth avenue take about 750 watts and consume in one year on the basis of 4,000 hours burning, 3,000 kilowatt hours, costing \$90, equal to \$45 per lamp. This figure is probably in excess of the actual cost. The difference between \$90 and \$182.50 (the bid per pair of 900 candle power lamps), equal to \$92.50, includes maintenance of the lamps, interest on the investment and profit. The total cost of maintenance per lamp should not at the outside be

ten dollars. The system used by the Edison Company is the direct current inclosed arc system, and it is used by them not because it is the most economical for street lighting, but because it fits in with other requirements, that is to say, with general commercial uses. On this system there is the loss in resistance of about 40 per cent. of the energy delivered to the lamp.

The city can adopt a system by which this loss can be largely saved.

The City of New York would have, therefore, three definite advantages over such a company as the New York Edison Company in supplying electricity for public uses:

(a) Low interest payments based on loans measured by funds actually required for construction as distinguished from the fixed charges which burden an inflated capitalization.

(b) The free use of subway rights which the city has had for years and from which it has until now benefited only to a small degree.

(c) Economy in construction and operation resulting from the adoption of all recent improvements and from having in view a single purpose—public lighting—without the complication incident to furnishing a general commercial supply.

On December 24, 1887, Chicago placed in operation its first municipal lighting station, and on the 24th of December last completed its fifteenth year of municipal ownership and operation of an electric lighting system. For the year 1902 the total cost per lamp of 2000 candle power per year is stated by it to be \$53.51. The City of Chicago also publishes a report showing all that has been expended for construction and operation of its electric light plant from 1887 to 1902. It has cost that city during sixteen years \$3,400,663.05. The

total amount rented electric lights would have cost Chicago for the corresponding period is \$3,535,875.50. I do not know that Chicago gives us the most successful example of municipal lighting, but their statement does not involve intricate questions of bookkeeping. It does show that Chicago has earned the cost of its electric plant, which includes the cost of considerable subway construction. The plant at present provides 4,640 arc lamps of 2000 candle power.

Detroit has also a municipal plant. In a report dated June 30, 1902, the cost of a 2000 candle power lamp for Detroit is given at \$63.82. That sum includes operating disbursements, interest of 4 per cent. on investment, depreciation of 3 per cent. and loss of taxes (that is to say, the taxes that would have been paid on a corresponding plant owned by a private company). The "Electrical World and Engineer" makes a critical analysis of this report in its issue of February 28, and expresses the opinion that 2000 candle power lamps cost the City of Detroit \$80 instead of \$63.50; \$80, however, compares very favorably with \$146 that we are asked to pay.

I believe that New York with its own plant could provide electric lighting for public uses at a cost much below what is now charged the city. Whether reasonable prices can be obtained from private companies or whether the city can with better results maintain and operate its own plant, is for you to determine. I do, however, urge that legislation be immediately asked and that you be given the power to establish and maintain an electric plant for street lighting in case later you decide that it is in the interest of the public so to do.

Respectfully,

R. G. MONROE,
Commissioner of Water Supply,
Gas and Electricity.

Extracts from Chart C, showing prices paid and number of lamps used in the electric arc lighting of the cities named, excluding all cities using less than 400 arc lamps.

Name of City.	No. of Lamps.	Price per Year.
Municipal plant, 1,200 c. p.—		
Grand Rapids, Mich.....	529	\$68.30
Municipal plant, 2,000 c. p.—		
Chicago	4,640	53.51
Detroit	2,133	63.82
Allegheny, Pa.....	1,414	74.20
Private plant, 1,200 c. p.—		
Rochester, N. Y.....	450	66.41
Savannah, Ga.....	513	72.00
Hartford, Ct.....	799	75.00
Springfield, Mass.....	900	75.00
New Haven, Ct.....	550	82.12
Bridgeport, Ct.....	525	83.00
Cambridge, Mass.....	553	100.00
New York.....	872	125.00
Private plant, 2,000 c. p.—		
Erie, Pa.....	449	61.86
Portland, Ore.....	712	64.52
Peoria, Ill.....	641	65.00
Dayton, Ohio.....	435	68.50
Salt Lake City.....	425	72.00
Washington, D. C.....	939	72.00
Cincinnati, Ohio.....	3,750	72.00

Name of City.	No. of Lamps.	Price per Year.
St. Louis, Mo.....	2,650	74.95
Rochester, N. Y.....	2,350	78.47
Los Angeles, Cal.....	1,050	81.00
Harrisburg, Pa.....	418	80.00
Atlanta, Ga.....	819	82.50
Kansas City, Mo.....	459	82.50
Cleveland, Ohio.....	1,075	82.92
Wilwaukee, Wis.....	1,812	82.98
Toledo, Ohio.....	1,012	83.00
Louisville, Ky.....	1,758	84.00
Indianapolis, Ind.....	1,500	85.00
Syracuse, N. Y.....	1,282	85.78
Denver, Colo.....	968	90.00
Omaha, Neb.....	446	94.50
Pittsburg, Pa.....	2,530	96.00
Jersey City, N. J.....	1,377	97.50
Newark, N. J.....	1,859	98.55
Baltimore, Md.....	1,584	99.82
New Orleans, La.....	1,664	100.00
Paterson, N. J.....	741	102.00
Worcester, Mass.....	744	109.50
Fall River, Mass.....	789	109.50
Utica, N. Y.....	693	109.50
Philadelphia, Pa.....	9,426	110.12
Manchester, N. H.....	494	115.00
Providence, R. I.....	1,870	120.2½
San Francisco, Cal.....	930	120.00
Camden, N. J.....	509	120.50
Albany, N. Y.....	671	121.80
Boston, Mass.....	3,670	124.10
New York.....	3,876	146.00

Experts' Report on Cost of Municipal Lighting in Chicago.

TWO widely divergent estimates have been made as to the cost per lamp per year for municipal electric lighting in Chicago. City Electrician Ellicott, in his report to the City Council February 2d, estimates that it costs the city only \$53.51 a lamp, while the arc lamps rented from the Chicago Edison Company cost \$103 a year. Haskins & Sells, the expert accountants who unraveled the intricacies of poor City Hall bookkeeping, made a report that the cost per lamp in 1900 was \$99.88. Mr. Ellicott bases his estimate on the expenditures last year, and, if the Haskins & Sells report were

carried out to December 31, 1902, it is probable that their estimate might be reduced to at least \$97.

The wide discrepancy between the two estimates is due to the fact that the city electrician does not take into account the water used free of charge, taxes, interest on investment, depreciation of plants and insurance.

All these items are considered by a private concern. The city electrician makes a better showing on the surface than would a private company, because his department is engaged in a co-operative business with the city water department. The latter furnishes him with water and

does not send in a bill. He furnishes the water department with lights and never sends in a bill.

In taking up the report of Haskins & Sells, Mr. Ellicott yesterday estimated charges along the lines of the expert accountants, but he could only bring the total cost per lamp to the city under municipal ownership up to \$74.56. He made this total under protest, maintaining all the time that the city should not be required to take into account whatever help it received from other arms of the municipal government. He maintained that even with a saving of \$3.12 over rented lights, as shown by the Haskins & Sells report, municipal ownership was a success. With an extra appropriation of \$200,000 a year for six years the city electrician says it would be possible to install 16,000 arc lamps for \$50 a year, exclusive of the charges estimated by the expert accountants. He holds that a saving of \$3 a year on this number of lamps would be satisfactory, but insists that the city would gain at least \$30 a lamp every year, as compared with the price for rented lights.

The Haskins & Sells estimate of cost per lamp for 1900 under city control is as follows:

Maintenance and operation—cost per lamp:	
	1900.
Coal	\$22.32
Oil, waste and boiler compound.....	.97
Operating labor.....	19.29
Repairs to buildings and equipments...	4.06
Rent65
Circuits	1.53
Conduits	1.15
Lamps	3.90
Globes50
Carbons	4.84
Posts11

Teams23
Miscellaneous	1.19
Office salaries.....	1.35
<hr/>	
Total maintenance and operation.....	\$62.09
Estimated charges—cost per lamp:	
	1900.
Water	\$4.14
Taxes	4.81
Insurance15
Interest	13.50
Depreciation	15.90
<hr/>	
Total estimated charges.....	\$37.79
Total cost per lamp per year.....	\$99.88

The official report of the city electrician, with his added estimates of charges, is as follows:

Coal	\$79,805.37
Carbons	22,338.49
Globes	2,328.07
Repairs to steam plants.....	9,802.08
Repairs to electric plants.....	4,986.05
Repairs to lamps.....	11,846.97
Repairs to underground circuits and aerial circuits.....	15,061.14
Other operations.....	7,728.97
<hr/>	
Total material.....	\$153,897.14
Salaries for operation of plants....	\$31,485.09
Arc lamp trimming.....	43,272.15
General superintendence of electric lighting system.....	8,242.05
<hr/>	
Total labor.....	82,999.29
Material, as above.....	\$153,897.14
Labor, as above.....	82,999.29
<hr/>	
Total cost of plants.....	\$236,896.43
Total cost, per lamp.....	\$52.55
Per cent. of office salaries.....	.96
<hr/>	
Grand total cost, per lamp...	\$53.51

Estimated charges—cost per lamp:	
	1902.
Water	\$2.75
Taxes	3.30
Insurance	None.
Interest	10.00
Depreciation	5.00
<hr/>	
Total estimated charges.....	\$21.05
Total cost per lamp per year.....	\$74.56

—Chicago Record-Herald.



The Growth of Niagara Power

THE fact that cheap Niagara power is going to do all that was claimed for it in the way of attracting industrial concerns to the Niagara frontier is being so thoroughly demonstrated that a second company—the Ontario Power Company—has secured rights from the Canadian Government. The development of its plant commenced last April, and 50,000 horse power will be the initial product, but this will be increased to 150,000 horse power. Instead of being carried in an underground tunnel, the water is directed into flumes, carried to the brink of the Niagara gorge, and then dropped into the river through penstocks, which develop the power.

These two companies are backed almost exclusively by United States capital. A third company, which claims to be wholly Canadian, has applied to the government for the privilege of developing 100,000 horse power near the two plants now under construction. A full hearing of all the parties interested was given by the government on Friday, December 19, at Toronto, and a decision will be announced shortly. As special stress is laid on the fact that a Canadian company should have preferential rights, it is believed that the petition will be granted. The Canadian Government exacts in all cases that 50 per cent. of the power developed must be provided to Canadian consumers if called for; the balance will be exported to the United States.

While millions of dollars are being expended in developing these various power plants, the revenue will be enor-

mous. Comparatively little labor is required, once the energy of Niagara is under control. When the 350,000 horse power now in process of development is placed on the market, the gross income of the power companies will be in the neighborhood of \$7,000,000 per year. This is figuring the price at \$20 per horse power a year, which is somewhat lower than the present average rate. As this provides constant power every day of the year, twenty-four hours every day, with thorough cleanliness, little fire or accident insurance, no expensive equipment for generating steam with its heavy annual wear and tear, no engineers or firemen—simply the turning of a lever—it is seen that for many lines of industry, Niagara electric power presents remarkable inducements.

The industrial growth of the Niagara frontier in the past few years has been marvellous. It is prophesied that within ten years 1,000,000 horse power will be in course of development. Up to the present time, the effect on the volume of water passing over the falls is not noticeable, even with the most careful measurements. A short time since, for the purpose of inspection, all the water was shut off from power development for a number of hours. Competent men were stationed at different points on the river and at the brink of the falls to measure the difference in the river level when the water producing 100,000 horse power was cut off. The men were unanimous in their reports that they could not detect the slightest variation. A heavy wind blowing up or down Lake Erie will

raise or lower the Niagara River several feet, but only those who are well acquainted with it will notice any special difference in the discharge at the cata-

ract. The main change is in the middle channel of the river and is principally shown in the rate of discharge, rather than the raising or lowering of the river.

Two Important Conventions

National Electric Light Association.

THE twenty-sixth convention of the National Electric Light Association will be held at Chicago, Illinois, May 26, 27 and 28, 1903. The headquarters of the Association will be at the Auditorium Hotel, and hotel rates will be as follows: Room with bath for two people, \$5 to \$6 per day; single room with bath, \$3.50 per day; rooms without bath (for each person), \$1.50 per day and upward; all on the European plan. A combination breakfast will be served in the Auditorium proper at a fixed price. Table d'hote luncheon will be served at sixty cents for each person and table d'hote dinner at \$1.25.

Rooms should be reserved as early as possible, as there is likely to be a very large attendance, and application should be made direct to the hotel management.

The American Street Railway Association.

THE twenty-second annual meeting of the American Street Railway Association will be held at the Grand Union Hotel, Saratoga Springs, New York, Wednesday, Thursday and Friday, September 2, 3 and 4, 1903.

Papers will be presented on the following subjects: "Electric Welded Joints," "The Evils of Maintenance and Champerty in Personal Injury Cases," "Train

Orders and Train Signals on Interurban Roads," "Freight and Express on Electric Railways," "The Manufacture and Distribution of Alternating Currents for City Systems," "Comparative Merits of Single and Double Truck Cars for City Service," "The Right of Way."

The Association expects to have a fine exhibition of street railway supplies, which will be held at the hotel.

The annual banquet will be held Friday evening, September 4, when the officers-elect will be installed.

The headquarters of the Association will be at the Grand Union Hotel, which is said to be the largest hotel in the United States. No rooms will be assigned prior to April 15, but those intending to be present should make application to the hotel early, as they will be assigned in the order in which received. Other first-class hotels are the United States, American-Adelphi, Congress Hall, Worden and Kensington. Railroad rates will probably be as in former years.

The following resolution was unanimously adopted by the committee: "The secretary is directed to request the chief executive officer of the different companies to notify all delegates and heads of departments attending the convention that they are expected to be present at all sessions of the meeting and take part in the discussions."

Book Reviews

The Art of Illumination.

By LOUIS BELL, Ph. D. McGraw Publishing Company, New York. Pp. 6x9 in., 339; illustrations, 127; cloth, \$2.50.

We believe that this is the only book in the language which deals directly with the scientific and artistic use of modern illuminants, electric and other. For this reason it is indispensable to architects and decorators, as well as to those engaged in the manufacture and sale of illuminants. The first three chapters are devoted to a discussion of the physical and physiological principles which form the basis of the art of artificial lighting. Then in succession are taken up the properties of practical illuminants and their bearing upon the development of modern lighting. The chapters upon electric incandescent lamps and arc lamps are especially rich in practical information regarding their economical and artistic use. The following chapter (VIII) on shades and reflectors contains a mass of data on this neglected topic which would require a long search to duplicate. Then the lighting of the house, of large buildings and of streets is treated in successive chapters, and concrete cases illustrative of the principles laid down are worked out in detail. A separate short chapter is devoted to the basic principles of decorative illumination for special purposes, and then the line of progress in the effective and economical use of the materials at hand is marked plainly out. The volume closes with a clear setting forth of the methods and apparatus employed

in modern photometry. The book is not burdened with technical details of construction, but treats of the intelligent and artistic use of illuminants as we have them, thereby filling a gap which has long existed. There are many manuals of gas and electric fittings, and of the technology of production and distribution, but we know of no other book that tells how to use illuminants effectively after one has them, and learn to make the most and best of them. It ought to be in the hands of every one who installs or uses artificial light.

The Induction Motor: Its Theory and Design.

By BOY DE LA TOUR, Chief Electrician and Designer, Electrical Department of the Compagnie Fives-Lille, Givars, France. Translated from the French by C. O. Mailloux, M. A. I. E. E., M. I. E. E. McGraw Publishing Company, New York. Pp. 6 $\frac{1}{4}$ x9 $\frac{1}{4}$ in., 250; 75 diagrams; cloth, \$2.50.

This work is intended to elucidate the theory of the induction motor, and to facilitate its design by a practical method of calculation which is at once simple, ingenious and effective. The object of the book is stated by the author in his preface as follows: "We have wished to come to the assistance of those who have not had occasion to take special courses, and who, owing to the lack of sufficiently extended knowledge, have not derived very much profit from all that has appeared in the scientific papers. We have, therefore, endeavored to give a complete study of the induction motor, and to explain, at length, all the peculiarities of its operation, while remaining within the

bounds of elementary mathematics." The book will be useful to all who desire information regarding the peculiarities of the induction motor, especially those who desire to study the effect of changes or modifications in design and proportions on the performance of the induction motor and its adaptability to different purposes. The work will be especially valuable to the designer who is looking for relatively simple rules and methods whereby the modifications in design and in details necessary to meet certain requirements may be predetermined.

Steam Power Plants—Their Design and Construction.

By HENRY C. MEYER, JR., M. E. McGraw Publishing Company, New York. Pp. 9½x6 in., 175, illustrated; cloth, \$2.

The matter in this book was written to give information to owners or managers of manufacturing plants or buildings requiring power installations, since they are from time to time called upon to specify or purchase the machinery needed for the proper equipment of their buildings, with a view to efficiency and economy in operation. While it is true wisdom to employ an expert to prepare plans and specifications for any important power plant, it is yet a fact, and likely to remain so, that the great bulk of steam installations will be made under the direction of men experienced in the details of manufacturing in their special lines, yet make no claim to expert knowledge in power plant engineering. To such the information presented in these pages will prove suggestive and valuable, as well as to the engineer, architect and student who desires general information on the subject treated. To the expert it

claims only to present in accessible and convenient form data useful in the practice of his profession.

Storage Battery Engineering.

By LAMAR LYNDON. McGraw Publishing Company, New York. Pp. 6½x9½ in., 382; 178 illustrations and diagrams, 4 large folding plates; cloth \$3.

This is a practical work intended for the electrical engineer who is called on to design and install storage battery equipments, or who has a battery power plant under his care. The first part deals with the storage battery, its construction, action under various conditions, deterioration and the causes of the observed phenomena. The treatment is almost entirely physical, the chemical theory involved being very limited in extent and elementary in character. The second part covers all the apparatus, devices and methods used in the application and control of batteries. The various systems of boosters are described and an analytical discussion of each type is given. Some of the most important systems are illustrated by practical examples. Altogether it forms a complete compendium for the engineer, to which any question that may arise in storage battery practice may be referred and satisfactorily solved.

Finances of Gas and Electricity Manufacturing Enterprises.

By WM. D. MARKS. Wm. D. Marks, Ph. B., C. E., 216 The Bourse, Philadelphia. Pp. 5x7½ in., 126; 1 diagram; paper, \$1.

This is the second edition of the above work. It contains two additional chapters—one on the price of gas in Massachusetts and another on the finances of district heating plants. An extended review of the first edition will be found in the October number of "The Electrical Age."

The Electrical Age

Incorporated April, 1902

CHARLES A. LIEB, - - - - PRESIDENT

New York, April, 1903

Volume XXX

No. 4

Published Monthly.

Subscription, \$1.00 per year. Single Copies, 10 Cents.
(\$2.00 Per Year to Foreign Countries.)

20 BROAD ST., NEW YORK. Telephone 1628 Cortlandt.

THE ELECTRICAL AGE (Incorporated)

Entered at New York Post Office as Second Class Matter.
Copyright, 1902, by THE ELECTRICAL AGE.

TO ADVERTISERS

Changes for advertisements and new advertisements **must** be in this office by the **20th** of the month to be included in the issue in the month following. The advertising pages carry printed matter measuring five and a half by eight inches. Cuts intended for use on these pages should be made to accord with these measurements.

Correspondence and semi-technical articles, with suitable photographs for reproduction, or cuts, are invited. Accepted matter will be promptly paid for. We cannot be responsible for any unsolicited manuscripts, but when stamps are enclosed all unavailable matter will be returned. Postage must always be fully prepaid. Cuts to be available for illustrating articles must conform to the column or page measurements. The columns are $2\frac{1}{2}$ inches wide. Cuts for single column use should not exceed that width. Cuts to go across the page should not be more than five inches wide, and full page cuts may not exceed $4\frac{1}{2} \times 8$ inches.

THE report made to the Mayor of New York City by Col. Monroe, Commissioner of Water Supply, Gas and Electricity—which is published in another part of this journal—has, of course, aroused an unusual amount of speculation and comment. The recommendation contained therein, that the city establish its own lighting plant, has given the municipal ownership movement added impetus, and its advocates are making the most of their opportunity.

The average citizen, who usually feels that he has a grievance against the lighting companies, believes that Commissioner Monroe's suggestion contains the proper panacea for the evil with which he imagines himself afflicted. Engineers and others who have made a

study of the attempts made by other municipalities to supply their own light, realize the commercial impracticability of the suggestion.

Mr. Charles F. Lacombe, Engineer of Surface Construction, in his report to the Commissioner, which lack of space forbids our publishing in this number, states that the City of Boston is often quoted as having made a careful examination of municipal ownership within the last few years, and finally decided to buy its lights from a private company. The reason for this is plain, he says. "The company made a contract with Boston which carries with it all the advantages of municipal ownership. In brief, after a period of two years and six months after signature, Boston had a right to establish exactly what it cost the electric light company to produce public lights, and the company was bound to aid them in every way to do this. They were then to add 7 per cent. for depreciation, and 6 per cent. for interest on the cost of the plant used for public lighting. For a period of five years the resultant price per arc lamp was to govern. Besides this, the company had to adopt any improved machinery or system. If it did not, the city could make a claim that it would only pay what lighting would cost when produced by such new system. If the City of New York had a contract of this kind, it is all we could ask. It is the essence of municipal ownership, as it makes the company practically the agent of the city." We might add that under the above arrangement Boston now pays \$124.10 per year for a 2,000 candle power lamp against \$146 paid by New York.

Much stress is laid upon Chicago's municipal lighting station by Commissioner Monroe. According to City Electrician Ellicott, this plant is oper-

ated at a cost of \$53.51 annually for each 2,000 candle power lamp. The report of the expert accountants, printed on another page, shows, however, that there is a considerable difference between the bookkeeping of Mr. Ellicott and their own, their report showing that it costs the city \$99.98 annually per lamp instead of the figure which he arrives at.

We agree with the "New York Times" that municipal ownership advocates always have been very bad bookkeepers, with a most deplorable tendency to ignore certain large items of expense which municipal plants can no more avoid than can the private corporations. "Not to get revenue that would otherwise come in is, of course, the same thing as paying it, and yet the public ownership advocates often forget this very obvious fact."

As the city lighting represents only about 5 per cent. of the business of the New York Edison Company, it would seem that an adoption of the rate charged the city of Boston—namely, \$125—would not seriously affect the earnings of the company, and would meet the present public demand. At the same time the Commissioner would feel that he had secured a victory. It would probably, in the end, result to the benefit of the lighting company, while, at the same time, the taxpayer would be spared the expense of supporting another political home for indigent ward-politicians.

ON March 3d one of the most remarkable patents in the history of electrical arts expired—one whose expiration would appear to remove the last obstacles in the way of

the development of an enormous industry. The patent referred to is that granted Charles F. Brush on March 3, 1886, covering completely the art of making storage battery plates by mechanically applying active material as a paste, powder, or in any other form, the claim reading, "Any mechanically applied material, either active or to become active." So broad is this claim that, in the opinion of a great many engineers, it is doubtful whether the Edison battery could have been put on the market while the patent was in force. What makes this patent so very remarkable is the fact that, although the very principle of the storage battery as developed from the beginning of the last century involved a metallic structure, the Brush patent absolutely covered the use of a metallic support in connection with any improvement offered, this claim practically closing the art to all except the owners of the patent. Thus, the many hundreds of patents which inventors brought out during the life of the Brush patent were rendered subsidiary to it. It would seem that electromobile manufacturers would profit more than any one else by the expiration of the Brush patent, as the storage battery heretofore used for driving electric vehicles has, as a rule, been very heavy; while as for power station batteries this business will remain in the hands of a few makers, as the regulation and storage, which can only be successfully accomplished by the use of automatic boosters, are covered by a large number of patents distributed among three battery manufacturing companies. Power work will thus be confined to these concerns.



New Inventions

For which Patents have been Granted



720,683. ENGINE STOP. William H. Dunn, Wallingford, Conn. Filed February 3, 1902. Serial No. 92,440. (No model).

In an engine stop, and in combination with the actuating mechanism, and a detent for holding the actuating mechanism in check, an electric circuit including an alarm mechanism, and a releasing mechanism for cooperation with the said detent, and an electric switch automatically operated by means of the aforesaid actuating mechanism to throw the alarm circuit into and out of action, substantially as set forth.

720,826. STEAM ENGINE. James W. Lyons, Chicago, Ill. Filed July 30, 1902. Serial No. 117,705. (No model.)

In combination with a fluid-pressure engine, an inlet or supply pipe; a valve for controlling said inlet, and a fluid-pressure motor in communication with the engine cylinder, subject to and actuated by the fluid

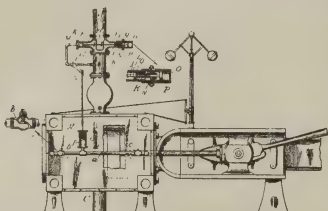

720,826. Steam Engine.

pressure within the same, and tending to operate the valve and thus to control the supply of fluid pressure commensurately with variations in the load.

721,703. ELECTRIC FURNACE. Paul L. T. Heroult, La Praz, France, assignor to Ste. Electro Metallurgique Francaise, Froges, Isere, France. Filed October 11, 1900. Serial No. 32,667. (No model.)

In an electric furnace, the combination of a crucible adapted to carry a bath of molten material, two electrodes supported above it and connected in series, a conductor in position to effect contact with material contained in the crucible and a voltmeter in shunt between one of said electrodes and said conductor, said conductor consisting of a rod passing through the refractory material of the crucible and projecting outside and inside

of the same whereby the portion of the rod which is melted is replaced by molten material which fills up the space and thus insures good conductivity.

721,669. ELECTRIC ENGINE. William T. Clark, Schenectady, N. Y., assignor to Tabor Manufacturing Company, Philadelphia, Pa., a corporation of New Jersey. Filed October 1, 1902. Serial No. 125,488. (No model.)

In an electric engine, a frame, a coil, a



721,669. Electric Engine.

plunger striker, a spring for moving said plunger outward, a blow transmitter rigidly connected with the frame and against which the coil draws the plunger, and a circuit-breaker operated by said plunger.

721,734. WIRE HOLDER FOR TROLLEY WIRES OF ELECTRIC RAILWAYS. Ludwig von Orth, Berlin, Germany. Filed December 26, 1901. Serial No. 87,157. (No model.)

In a holder for electric railway trolley wires, the combination of a non-flexible holder adapted to support the strained wire, and an auxiliary flexible holder connected at one end to the non-flexible holder and at its other end to the wire and being normally under no strain from said wire, substantially as and for the purpose set forth.

721,670. ELECTRIC ENGINE. William T. Clark, Schenectady, N. Y., assignor to Tabor Manufacturing Company, Philadelphia, Pa., a corporation of New Jersey. Filed October 1, 1902. Serial No. 125,489. (No model.)

In an electric engine, the combination of adjacent aligned electro-magnet coils, a casing having short cores projecting into said coils, a reciprocatory striker between said cores, a disk on said striker and between the adjacent ends of said coils, adjacent contact terminals connected with said coils, and an arm moved from one to another of said terminals by said disk to make and break the circuit through said coils alternately.

720,981. APPARATUS FOR MEASURING THE ENERGY OF ELECTRIC CURRENTS. William Stanley, Great Barrington, Mass., assignor to Stanley Instrument Company, Great Barrington, Mass., a corporation of Massachusetts. Filed July 16, 1902. Serial No. 115,753. (No model.)

In a meter, the combination of a series coil, a shunt coil free to oscillate relatively thereto, a time beater acting to cause said

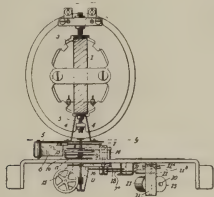

720,981. Apparatus for Measuring the Energy of Electric Currents.

shunt coil to oscillate and means operated thereby for integrating the torque due to the current in said shunt and series coils at the ends of periods, each embracing a number of such oscillations.

721,770. ELECTRIC THERMOMETER. Anthony Zeleny, Minneapolis, Minn., assignor to one-half to C. E. Thayer, Minneapolis, Minn. Filed June 9, 1902. Serial No. 110,744. (No model.)

The combination with a galvanometer, of a thermo-electric circuit having constant temperature and variable temperature thermo-electric junctions, the constant temperature junction being located in the earth below the zone of changing temperature, and the variable temperature junction being located at a point the temperature of which is to be determined, substantially as described.

721,942. ELECTRIC SWITCH SYSTEM. Adolph L. De Leeuw, Hamilton, Ohio, assignor to the Niles Tool Works Company, Hamilton, Ohio. Filed November 24, 1902. Serial No. 132,553. (No model.)

In an electric switch system, the combination, substantially as set forth, of a normally open first circuit, a translating device included therein, a first switch for temporarily closing said open circuit, a second circuit, a second translating device included in said second circuit, mechanism operatively connecting the second translating device with said first switch, a second switch disposed in the second circuit and having alternative contacts of closure, a first hand switch and a second hand switch, each having alternative contacts of closure, and electrical connections between said hand switches and circuits, whereby one position of the first hand switch results in the first translating device being energized only under one selected condition of said second switch and thereby

another position of the first hand switch results in the first translating device being energized only under another selected condition of said second switch and whereby the shifting of the second switch causes the first translating device to be energized under a plurality of conditions of said second switch, substantially as set forth.

720,951. ELECTRIC BRAKE. Frank C. Newell, Wilkinsburg, Pa., assignor to the Westinghouse Air Brake Company, Pittsburg, Pa., a corporation of Pennsylvania. Filed April 18, 1901. Renewed December 22, 1902. Serial No. 136,243. (No model.)

In an electric brake mechanism, the combination with a running controller having a handle adapted to be moved in one direction from its neutral or off position for running and in the opposite direction for braking, of mechanism operated by said handle for causing the movable contact bars of the controller to move in the same direction from the off position when the controller handle is moved in either direction from said position.

720,609. ELECTRIC LIGHTING SYSTEM. James F. McElroy, Albany, N. Y. Filed January 16, 1902. Serial No. 89,950. (No model.)

In an electric lighting system the combination with a variable-speed dynamo of an automatic switch for connecting it to the

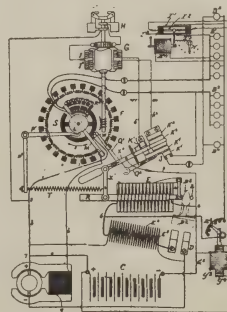

720,609. Electric Lighting System.

circuit, electric lamps and storage battery in multiple, and a regulating magnet for the dynamo included in the branch circuit leading to the battery.

720,577. ELECTRIC BATTERY. Edwin R. Gill, New York, N. Y., assignor to Invention Developing Company, a corporation of New Jersey. Filed June 26, 1900. Serial No. 21,680½. (No model.)

In a test set, a retaining block containing cavities opening at one surface of the block, battery cells in said cavities projecting slightly beyond their orifices, and means operating by spring tension for holding said cells in place, substantially as described.

722,042. ELECTRO-MAGNETIC MOTOR. Angel Pol y Aguirre, Havana, Cuba. Filed August 28, 1902. Serial No. 121,334. (No model.)

An electro-magnetic motor, comprising a frame provided with bearings, a revoluble shaft mounted upon said bearings, twin members of non-magnetic material mounted upon said shaft and provided with facets, said twin members being so disposed that said facets are staggered relatively to each other, electro-magnets upon said facets and disposed in separate groups staggered relatively to each other, a distributing ring connected with every second electro-magnet of each group, a collector ring connected with the magnets not thus connected with said distributing rings, commutators and brushes for connecting said collector rings and said distributing rings with respective mains of opposite sign, a plurality of permanent bar-magnets mounted upon said frame and arranged in the form of a cage, each bar being of opposite polarity to other bars immediately adjacent thereto.

721,128. MULTIPLE SERIES SYSTEM OF ELECTRICAL DISTRIBUTION. Frederick H. Loveridge, Coldwater, Mich., and Charles D. Haskins, Chicago, Ill., assignors to the Western Electric Company, Chicago, Ill., a corporation of Illinois. Filed November 9, 1896. Serial No. 611,504. (No model.)

In a multiple series system of electrical distribution, the combination with a main source of current, of main and compensating conductors between which the translating devices are connected, an armature connected between said main conductors and in series with a field winding which varies the magnetic field in which the armature is disposed, a second armature connected in series with a second field winding in a branch separate from the last-named circuit, this field winding also varying the field in which the latter armature is disposed, the latter armature and field winding being in parallel with the translating devices of one of the branches of the system, the dynamo electric machines composed of the aforesaid armatures and fields associated therewith having their rotating elements mechanically united whereby the magnetic fields are varied inversely and the potential thereby maintained in the several branches of the system, substantially as described.

720,898. MEANS FOR DISSIPATING ELECTRICITY IN SHEETS OF PAPER. Thomas C. Dexter, Pearl River, N. Y., and Thomas E. Breen, Colwyn, Pa. Filed March 17, 1902. Serial No. 98,656. (No model.)

In combination with a machine adapted to operate upon sheets of paper, an air blast having an outlet for the blasts of air, a gas burner pipe located in said air blast device, a gas supply pipe communicating with said burner pipe, an air supply pipe also

communicating with said burner pipe, and an air pump or blower communicating with said air supply pipe, substantially as set forth.

720,592. ELECTRIC BATTERY. Milton M. Kohn, Chicago, Ill. Filed July 31, 1895. Serial No. 557,661. (No model.)

In an electric battery, the combination with a retaining vessel, positive and negative elements, and an excitant therein, of means for sealing said retaining vessel, a valve, 24, having passages, 27, and a threaded passage, 26, communicating with the passages, 27, and with the atmosphere, and a threaded plug fitted in the upper end of said threaded passage, substantially as described, and for the purpose specified.

720,596. ELECTROMAGNETIC RECIPROCATING TOOL. Cloyd Marshall, Lafayette, Ind., assignor to James S. Andrews, St. Louis, Mo., and William M. Simpson, Chicago, Ill. Filed June 8, 1901. Renewed July 18, 1902. Serial No. 116,074. (No model.)

The combination with a plunger and a pair of solenoids for reciprocating the same, of an external rotary commutating device comprising a series of disks of different diameters and means for operating the same to alternately energize the solenoids and momentarily short-circuit each solenoid at the time its circuit is broken.

722,030. APPARATUS FOR MEASURING AND INDICATING ELECTRICITY SUPPLY. Charles H. Merz, Westminster, England. Filed September 25, 1902. Serial No. 124,877. (No model.)

Combined electric measuring and indicating apparatus capable of integrating the amounts of electricity that shall have passed through the apparatus during a number of equal intervals of time and of indicating the greatest of these amounts, said apparatus comprising an integrating meter, a body adapted to be actuated during each interval of time to an extent dependent upon the total quantity of electricity that shall have passed through said apparatus during the interval, an indicator adapted to be moved in one direction by said body and to remain in the position into which it is moved, and means for returning said body to its original position at the end of each interval of time.

722,176. SYSTEM OF PRODUCING ELECTRICAL SPARKS FOR IGNITING THE CHARGES OF EXPLOSIVE ENGINES. George W. Euker, Richmond, Va., assignor to Edwin O. Meyer, Richmond, Va. Filed July 9, 1902. Serial No. 114,850. (No model.)

In a sparking mechanism for explosive engines and in combination, a single main circuit, a battery and dynamo located in said circuit connected up in reverse order, and make-and-break mechanism also located in said circuit, substantially as described.



Incorporations and Franchises



ARKANSAS.

De Queen—The De Queen Light, Ice and Cold Storage Company has been incorporated, with a capital of \$50,000. J. S. Lake is president, I. O. Bunyan, secretary.

CALIFORNIA.

Watsonville—The Watsonville Transportation Company has been incorporated, with a capital stock of \$1,000,000. F. A. Kilburn, R. W. Eaton and H. H. Main are among the incorporators of the company.

GEORGIA.

Atlanta—The Atlanta & Marinetta Electric Railway Company will apply for a charter. The capital will be \$600,000. D. B. Gray, of New York; P. D. McCarley, of Fulton County, and others, are among the incorporators.

ILLINOIS.

Quincy—The Independent Light and Power Company has been incorporated, with a capital of \$200,000. Incorporators, J. W. Cassidy, C. E. Mead and L. P. Wheeler.

INDIANA.

Kokomo—The Kokomo, Converse & Marion Traction Company has been incorporated, with a capital of \$10,000. O. V. Darby, G. E. Bruner and T. C. McReynolds, Kokomo; J. E. Kenney, Converse, and H. D. Thomas, of Marion, are the officials.

Indianapolis—The Huntington, Columbia City & Northern Traction Company has filed articles of incorporation. Capital stock, \$50,000. John A. Knitz is president; W. A. Jones, vice-president, and B. E. Gates, secretary, all of Huntington.

Indianapolis—The Knox, Chicago & Northern Traction Company has been incorporated. The capitalization is \$150,000. J. C. Flecher, of Knox, is the president and financial head.

IOWA.

Odebolt—The Odebolt Lighting and Heating Company has been incorporated, with a capital of \$12,000. Joseph Mattes is president and E. W. Lester secretary.

Guthrie Center—The Guthrie Center Electric Light Company has been incorporated, with a capital of \$15,000, by W. F. Moore, C. G. Trent, Sr., Alex. H. Grisell and others.

LOUISIANA.

New Orleans—The Southern Light and Traction Company, of New Orleans, has been incorporated, with a capital stock of \$500,000, to build electric railways and power plants in the interior towns of Louisiana and Mississippi. The officers are Sol. Wesler, president; J. H. Ingwerson, vice-president; G. H. Hovey, secretary; R. J. Kennedy, treasurer.

MAINE.

Winterport—The Winterport, Frankfort & Prospect Electric Railway is seeking incorporation. Charles A. McKenney, Frank C. Young, Charles R. Hill, of Winterport, and Albert Pierce, of Frankfort, are among the incorporators of the company.

Camden—The Camden, Liberty & Belfast Railway Company has applied for a charter to build an electric railway through Camden, Liberty and Belfast, a distance of 20 miles. The power plant is to be located at Liberty. Capt. John J. Crowley, of Taunton, Mass., and Charles E. Littlefield, of Rockland, Me., are interested.

Cherryfield—Application has been made to the Legislature for the incorporation of the Cherryfield & Millbridge Street Railway Company, with a capital not exceeding \$100,000. E. R. Wilson, of Cherryfield, and George A. Sawyer, of Millbridge, are interested.

MASSACHUSETTS.

Beverly—The Gloucester, Magnolia & Beverly Street Railway Company will apply for a franchise. Judge Edgar Tate, of Gloucester, is interested.

Chelsea—Application has been made to the Legislature for the incorporation of the Marginal Street Railway Company. The plan is to build a three-mile freight railway along the water front of the city. Joseph W. Stickney, of Chelsea, is interested.

MICHIGAN.

Monroe—The Monroe Heating and Lighting Company is about to be organized, with Charles Flowers, of Detroit, and Fred C. Nadeou, of Monroe, as incorporators.

MISSISSIPPI.

Collins—The Collins Light and Power Company, of Collins, has been incorporated, with a capital of \$10,000. Incorporators, W. E. Payne, H. Swinney and others.

NEW HAMPSHIRE.

Littleton—The Littleton, Franconia & Bethlehem Electric Railway Company, to be capitalized at \$100,000, is seeking incorporation. The plan is to develop Fifteen-Mile Falls, in the Connecticut River, for power. A. S. Batchellor, of Littleton, is interested.

NEW JERSEY.

Pitman Grove—The New Jersey Southern Gas and Electric Company, of Pitman Grove, has been incorporated, with a capital of \$500,000, by J. H. McNeal, R. M. Anderson and A. M. Worstall.

Trenton—The Trenton, Lakewood & Atlantic Traction Company, with a capital of \$1,000,000, has been chartered. The road will run from Trenton to Lakewood. The incorporators are George O. Vanderbilt and Albert D. Cook, of Princeton; Thomas P. Allen, Joseph H. Allen, Peter Schlichner, William Allfuther and Richard N. Page, of Trenton; William B. Wills, of Mount Holly, Abel B. Haring and William H. Martin, of Frenchtown; Jacob Wyckoff, of Princeton Junction; James C. Robbins, of Hamilton Square, and Albert T. Eckles, of Milford.

NEW YORK.

Dansville—The Mill Creek Electric Light and Power Company, of Dansville, has been incorporated, with a capital of \$200,000, by F. A. Owen, Walter A. Beecher and others, all of Dansville.

NORTH CAROLINA.

Elizabeth City—A charter has been granted to the Elizabeth City Light and Power Company, which has a capital of \$100,000, and the Elizabeth City Water and Power Company, with a capital of \$100,000. The incorporators of both companies are: David B. Banks and M. W. Offut, of Baltimore, Md., and C. M. Ferebee, of Elizabeth City.

PENNSYLVANIA.

Sellersville—The Sellersville Electric Light and Power Company has been incorporated, with a capital stock of \$15,000, to be directed by Henry J. Wombold, of Telford; Morris H. Clymer and Mamie E. Clymer.

Hummelstown—Application has been made for a charter for the Hummelstown & Campbellstown Street Railway Company.

Donora—The Donora Light, Heat and Power Company has been incorporated, with a capital stock of \$5,000.

Clearfield—The Centre & Clearfield Street Railway Company has organized as follows: J. G. Platt, president; O. L. Schoonover, vice-president; James Passmore, treasurer; H. B. Hartswick, secretary; James Passmore, Jacob Swires, A. J. Graham, George W. Hawtorp, C. E. Murray, J. H. Turnbach, John G. Platt, C. H. Rowland, H. M. Hughes and O. L. Schoonover, directors.

OHIO.

Toledo—The Toledo & Interurban Railway Company is to be incorporated under the laws of Ohio to build a line from Pioneer to Goshen, Ind.

Leesburg—The Leesburg Manufacturing, Light and Power Company has been incorporated, with \$25,000 capital stock, by R. P. Barret, W. E. Dibble, H. A. Leeson and others. They will erect a lighting plant.

Piqua—The Miami Light, Heat and Power Company has been incorporated, with \$150,000 capital, to construct an electric light and heating plant in Piqua. Incorporators: S. B. Hartman, W. V. Baker and F. W. Bailey, of Columbus, and H. T. Bailey, J. W. Brown and A. E. Clark, of Piqua.

Oberlin—The Oberlin Electric and Heating Company has been incorporated, with \$50,000 capital stock to build an electric lighting and steam heating plant in Oberlin. Incorporators, A. M. Loveland, A. G. Comings, Y. D. Yocum, C. K. Whitney, L. B. Fauver and L. E. Burgner.

SOUTH CAROLINA.

Sumpter—The Sumpter Ice, Light and Power Company, capital \$70,000, has been chartered by Charles T. Mason and Perry Moses.

Spartanburg—The Electric Manufacturing and Power Company is about to be formed here, with a capital of \$100,000, by local capitalists, to develop the water power on French Broad River, 35 miles from this city and near Tyron, N. C. John B. Cleveland and J. N. Cudd are reported interested.

WEST VIRGINIA.

Wheeling—The Wheeling, West Liberty & Belt Railway Company has been incorporated. Among the incorporators are C. L. Gill, Will Chambers, Will Gutman, James W. Ewing and E. Ball.

WISCONSIN.

La Crosse—Interests identified with the La Crosse Street Railway Company have just incorporated the La Crosse & Northern Railway Company, which will build an electric railway from La Crosse to Winona.

Kenton—The Kenton & Southern Traction Company has been organized, with J. S. Harshman, Springfield, president; R. Emery, Columbus, vice-president and secretary; S. D. McGomery, secretary. The capital stock is \$600,000, with bonds for the same amount.

Springfield—The Springfield Southern & Cincinnati Railroad Company has been incorporated, with \$25,000 capital stock, by George H. Frey, Jr., James Johnson, E. B. Hopkins, Charles R. Crain and J. D. DeWitt.

Zanesville—The Muskingum Valley Traction Company has been incorporated, with \$100,000 capital stock, by S. A. Weller, W. B. Cosgrove, N. P. Shurtz, J. G. England and S. M. Winn.

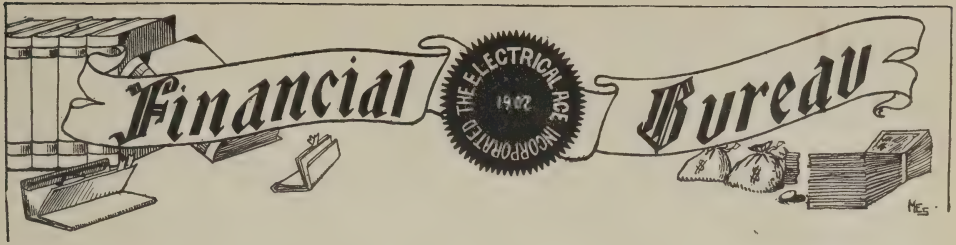

Street railway companies, electric lighting companies and gas companies which desire their reports to appear in the Financial Bureau of THE ELECTRICAL AGE are requested to forward the information so that it may reach us by the 20th of each month. Monthly reports are requested showing gross receipts and when possible operating expenses. Companies are also requested to furnish the highest and lowest prices for which their stock has sold in the market for the previous month.

Street Railway and Other Statements

Companies.	Date.	Gross Earnings.		Net Earnings.	
		1903.	1902.	1903.	1902.
ANN ARBOR RAILROAD.....	Jan.	\$157,339	\$157,490	\$15,320	\$57,675
July 1 to Jan. 1.....		1,131,556	1,120,877	372,378	357,816
AMSTERDAM STREET RAILROAD.					
Quarter ended Dec. 31.....		16,008	10,717	4,618	631
BLACK RIVER TRACTION.					
Quarter ended Dec. 31.....		15,116			
CROSTOWN STREET RAILWAY.					
Quarter ended Dec. 31.....		125,422		58,815	
		1903.	1902.	1903.	1902.
CLEVE. & SOUTHWESTERN TR....	Feb.	25,334	16,252	7,776	4,251
CENT. & SO. AMERICAN TELEGRAPH.					
Quarter ended March 31.....		258,000	260,000	156,000	159,000
CENTRAL CROSTOWN RAILROAD.					
Quarter ended Dec. 31.....		121,293	134,106	41,629	46,883
D. DOCK, E. B'WAY & BATTERY R. R.					
Quarter ended Dec. 31.....		142,824		30,910	
DETROIT UNITED RY. (all properties).					
Jan.		312,984	288,707	117,046	119,489
Feb.		283,034	256,785	105,928	102,323
Jan. 1 to Feb. 28.....		596,018	545,493	222,974	221,812
Fourth week Feb.....		69,570	63,294		
March.		271,392	246,830		
From Jan. 1.....		572,436	522,422		
Second week March.....		70,198	65,038		
From Jan 1.....		735,641	673,939		
42D ST., MANHATTANV. & ST. N. AV.					
Quarter ended Dec. 31.....		212,256	1901.	1902.	1901.
HUDSON VALLEY RAILWAY.					
Quarter ended Dec. 31.....		50,133		88,125	
HUDSON RIVER TELEPHONE.					
Quarter ended Dec. 31.....		787,330	672,590	236,564	225,778
INTERURBAN STREET RAILWAY.					
Quarter ended Dec. 31.....		3,875,179		1,955,095	
JEROME PARK RAILWAY.					
Quarter ended Dec. 31.....		750			
KINGSBRIDGE RAILWAY.					
Quarter ended Dec. 31.....		8,646		1,473	
GAS & ELECTRIC LIGHT COMPANIES					
OF MASSACHUSETTS.....		7,968,098	7,484,303	2,210,150	2,113,062
MEXICAN TELEGRAPH.					
Quarter ended March 31.....		115,000	117,000	94,000	93,000
MEXICAN TELEPHONE.....	Jan.	21,487	18,833	8,553	9,361
March 1 to Jan. 31.....		224,954	196,715	102,471	90,229

Companies.	Date.	Gross Earnings.		Net Earnings.	
METROPOLITAN SUBSIDIARY CO.'S.					
Quarter ended Dec. 31.....		1902.	1901.	1902.	1901.
34TH STREET CROSSTOWN.....		125,402	114,874	46,463	40,134
28TH & 29TH STS. CROSSTOWN...		48,607	46,379	23,479	17,902
FULTON STREET.....		8,933	10,211	1,232	2,652
N. Y. & N. J. TELEPHONE.					
Quarter ended Dec. 31.....		3,962,597	3,376,432	1,139,140	1,081,799
ORANGE COUNTY RAILROAD.					
Quarter ended Dec. 31.....		4,059			
SKANEATELES RAILROAD.					
Quarter ended Dec. 31.....		10,675			
SYR., LAKESIDE & BALDWINVILLE.					
Quarter ended Dec. 31.....		12,017			
SYRACUSE & SUBURBAN.					
Quarter ended Dec. 31.....		17,667	15,624	8,188	7,106
SYRACUSE LIGHTING COMPANY.					
Year ended July 1.....		338,228		172,814	
TWIN CITY RAPID TRANSIT.....Jan.					
Third week Feb.....		311,837	272,158	103,262	139,739
From Jan. 1.....		69,439	60,884		
Fourth week Feb.....		518,730	451,512		
Month.....		72,300	62,122		
From Jan. 31.....		280,946	243,149		
Feb.....		591,031	513,035		
Jan. 1 to Feb. 28.....		282,600	244,780	142,151	124,509
First week March.....		594,438	516,939	305,414	264,247
From Jan. 1.....		70,458	62,533		
Second week March.....		661,489	576,188		
From Jan. 1.....		71,599	62,809		
From Jan. 1.....		733,088	638,277		
TERMINAL RAILWAY OF BUFFALO.					
Quarter ended Dec. 31.....		1902.	1901.	1902.	1901.
		11,706			
THIRD AVENUE RAILROAD.					
Quarter ended Dec. 31.....		560,353	583,368	217,701	187,836
		1903.	1902.	1903.	1902.
		115,148	100,885	54,034	48,362
TOLEDO RAILWAYS & LIGHT...Feb.					
Jan. 1 to Feb. 28.....		240,642	214,063	117,131	103,773
UNITED ELECTRIC OF NEW JERSEY.					
Year ended Jan. 31.....		1,854,305	1,677,322	744,264	753,414
UNITED RY. OF SAN FRANCISCO.					
Year ended Dec. 31.....		5,553,904	1901.	1902.	1901.
				2,259,775	
WAVERLEY, SAYRE & ATHENS TR.					
Quarter ended Dec. 31.....		14,157.			

Stated Reports of Companies

Hudson River Telephone Company

The annual meeting of the stockholders of the Hudson River Telephone Company was held March 5. The report showing the

Gross revenue.....	1902.	\$787,330
Gross expenses.....		550,766
Net revenue.....		\$236,564

Dividends at the rate of 6 per cent. were continued during the year, amounting to \$199,528, leaving the balance over dividends for the year \$37,035.

In comparing the figures with those of 1901, it will be borne in mind that the company operated the Northern New York Telephone Company only eight months and the

operations of the company and its financial condition for the year ended December 31 last is as follows:

	1901.	Changes.
Inc.	\$672,590	\$114,740
Inc.	446,802	103,964
Inc.	\$225,788	\$10,776

Troy Telephone & Telegraph Company only six months of 1901. The revenue from exchange service for 1902 was \$557,791, as against, for 1901, \$463,529. And the revenue from toll service for 1902 was \$206,585, as against, for 1901, \$158,704. The net increase in subscribers during the year was 4,404.

The expenditure for maintenance of the

plant was increased \$50,000 over that of the previous year, the total of such expenditure for the year 1902 being \$222,256.

There was sold, and the proceeds applied toward work of the year, new stock to the amount of \$404,100. The excess of current obligations above the cash and bills receivable in hand at the close of the year will be cared for by the sale of new stock, as will

Resources—

Construction and franchise, Jan. 1, 1902	\$3,303,420
Construction added during 1902...	617,093
Supply department	93,984
Real estate	220,024
Stocks and bonds.....	10,400
Accounts receivable.....	144,804
Cash	16,082
Total.....	\$4,385,809

also such new work as may be undertaken during the year.

The total number of telephones in the company's service on December 31 was 18,992, of which number 4,552 were maintained in Albany.

The general balance sheet of the company on December 31, showed:

Liabilities—

Capital stock.....	\$3,613,200
Surplus	376,938
Reserve for unearned rentals.....	1,106
Reserve for outstanding toll tickets	1,286
Real estate mortgage.....	4,000
Bills and accounts payable.....	389,277
Total.....	\$4,385,809

Syracuse Lighting Company

The Syracuse Lighting Company, which controls the entire electric light and power and gas business of the City of Syracuse, in its application to list certain securities on the stock exchange, reports for the fiscal year ended July 1, 1902, being the first year of its operation, and before the property of the Syracuse Gas Company had been acquired:

Assets—

Plants and franchises.....	\$7,969,928
Construction accounts	74,266
Stock on hand.....	90,976
Cash	39,016
Accounts receivable.....	107,404
Miscellaneous	8,986
Operating expenses.....	178,830
Fixed charges.....	102,225
Dividends paid, Nov. 1, 1902.....	12,500
Total.....	\$8,584,131

Gross income, \$338,288; operating expenses, \$165,473; net earnings, \$172,814; interest on bonds, \$100,000; balance, \$72,814; dividends, 5 per cent. on preferred stock, \$50,000; surplus, \$22,814.

The general balance sheet as of December 31, 1902, shows:

Liabilities—

Preferred stock.....	\$1,000,000
Common stock.....	3,000,000
First mortgage 5 per cent. gold bonds	2,000,000
First mortgage 5 per cent. gas bonds	2,089,000
Accounts payable.....	101,434
Taxes payable.....	76
Interest accrued.....	8,333
Consumers' deposits.....	3,439
Bad debt reserve.....	1,650
Profit and loss.....	15,845
Earnings electric department from July 1, 1902.....	199,424
Earnings gas department from July 1, 1902.....	162,637
Income, other sources.....	2,293
Total.....	\$8,584,131

United Railroads of San Francisco.

The United Railroads of San Francisco submits the following income account for the year ended December 31 last: Gross earnings, \$5,533,904; operating expenses and taxes, \$3,274,129; net earnings, \$2,259,775; other income, \$31,312; total income, \$2,291,-

Assets—

Railroads, properties and franchises	\$71,610,669
Additions and betterments to property	1,125,516

087; deductions from income, \$2,406; net income, \$2,288,681; fixed charges, \$1,438,050; surplus, \$850,631.

The balance sheet as of December 31, shows:

Liabilities—

Capital stock, common.....	\$20,000,000
Capital stock, preferred.....	20,000,000
Sinking fund 4 per cent. gold bonds	35,275,000

Market Street Railway Company 5 per cent. bonds in treasury.....	1,500,000	Underlying bonds assumed:	
Mortgage sinking funds invested..	653,643	Market Street Railway Company 5 per cent.....	6,641,000
Fund for improvements and betterments	930,314	Market Street Cable Railway Company 6 per cent.....	3,000,000
Sinkings fund 4 per cent. gold bonds reserved:		Omnibus Cable Co. 6 per cent....	2,000,000
For future betterments, improvements and acquisitions.....	5,409,000	Powell Street Railway Co. 6 per cent.	700,000
For underlying liens.....	9,866,000	Ferries & Cliff House Railway Co. 6 per cent.....	650,000
Special deposits for purchase of outstanding stocks, Market street, Sutter and Sutro companies (see contra).....	53,898	Park & Cliff House Railway Co. 6 per cent.....	350,000
Stock pro rata interest in assets of constituent companies.....	66,970	Park & Ocean Railroad Company 6 per cent.....	250,000
Materials and supplies.....	357,362	Sutter Street Railway Company 5 per cent.....	1,000,000
Cash with treasurer.....	517,211	Constituent companies, liability to outstanding stocks of Market Street, Sutter and Sutro companies (see contra).....	53,898
Cash on deposit to pay interest...	145,607	Accounts payable.....	334,613
Cash on deposit to pay bond coupons due.....	5,140	Pay rolls	133,369
Bills receivable.....	15,435	Unclaimed wages.....	1,888
Accounts receivable.....	41,802	Employees' deposits	43,942
Unadjusted accounts.....	6,024	Employees' hospital fund.....	4,188
Deferred assets:		Tickets sold, unredeemed.....	1,692
Insurance premiums paid, not accrued	4,492	Bond interest, due and unpaid....	130,025
Taxes paid, not accrued.....	30,960	Interest on bonds, accrued, not due	351,017
Coupons paid, not matured.....	100	Sinking funds, accrued, not due...	60,000
		Miscellaneous interest, accrued, not due	705
		Reserve for mortgage sinking funds	771,450
		Reserve for insurance.....	176,238
		Reserve for dividends.....	41,846
		Profit and loss (surplus Dec. 31, 1902)	369,272
Total.....	\$92,340,143	Total.....	\$92,340,143

Financial Notes

The railroad commissioners have authorized the West End Street Railway Company to issue \$454,250 additional common stock.

The Illinois & Indiana Telephone & Telegraph Company has been incorporated at Trenton with a capital of \$2,000,000, to carry on a general telephone and telegraph business.

The Manila Railways & Light Company has been incorporated at Trenton with \$1,000,000 capital stock to operate street and other railways and to establish electric and gas plants in Manila, P. I.

Murray Crane has been elected a director of the American Telephone & Telegraph

Company to succeed J. H. Cahill, resigned. Mr. Crane was also elected a director of the American Bell Telephone Company.

At the special meeting of the stockholders of the Kings County Electric Light & Power Company, held in Brooklyn March 18, it was voted to increase the capitalization of the company from \$2,500,000 to \$5,000,000.

The Lubec & Machias Railway has been incorporated to build a steam or electric line between the points named. Lines will be built this year from Belfast to Camden and from Hampden to Stockton Springs.

It is said that capitalists in New York City and New Jersey have organized a com-

pany under the laws of the latter State to perfect a canal electric third rail system, and that the scheme will be presented to the Joint Committee on Canals.

It is said the Toledo & Chicago Interurban Railway Company is being organized by people largely interested in the Toledo & Western Railway Company to build, or buy an electric line from the western terminus of the Toledo & Western to Goshen.

Secretary E. T. Hance, of the Union Trust Company, has announced that his company, as receiver for the Michigan Telephone Company, has declined the offer of \$125,000 cash made by the Citizens' Telephone Company of Kalamazoo, for the Bell plant in that city.

A new company will be formed to consolidate the Easton and Phillipsburg gas and electric light plants, and will construct fifteen or twenty miles of new mains. The properties have been bought by local brokers. No trolley lines have as yet been bought.

The net passenger earnings of the Elgin, Aurora & Southern Traction Company for the month of February were \$24,804, against \$22,322 in 1902, an increase of \$2,471. These figures are exclusive of miscellaneous earnings and the earnings of the electric lighting department.

The Buenos Aires Grand National Tramways Company, Limited, a corporation controlled in London, proposes to convert its lines to an electric traction system. About thirty miles will be converted at once. The company now operates the largest horse car system in the world.

The directors of the Laclede Power Company have voted to increase the capital stock from \$800,000 to \$2,000,000. The increase in capital is stated to have been made because the company needs a larger working capital. The present stockholders will subscribe for the additional issue.

President A. G. Wheeler, of the Illinois Telephone Company, which is preparing to compete with the Chicago Telephone Company, says: "Within three months the Illinois Telephone & Telegraph Company will have in operation in the downtown district 10,000 of its new "secret service 'phones."

The Union Pacific Railroad Company and the Postal Telegraph Company have come to an agreement by which the Postal company will build a line of wire on the Union Pacific right of way from Omaha to the Pa-

cific Coast. The work of construction will begin at once. The total cost of construction will be \$1,500,000.

Minister of the Interior von Plehwe, of Russia, has informed the Mayor of St. Petersburg that the government has refused the application of Murray A. Verner, of Pittsburg, Pa., for the St. Petersburg & Moscow traction franchises. Both municipalities opposed the applications. They desire to construct the street railroads themselves.

The St. Louis Transit Company is preparing to float \$6,000,000 6 per cent. gold debenture collateral trust bonds secured by \$25,000,000 United Railways common stock, some United Railways preferred and St. Louis Transit common stock. The proceeds will pay off \$2,000,000 floating debt and pay for 500 cars, costing \$2,250,000. The bonds will probably be sold between 75 and 85.

Capitalists of Huntington, W. Va., headed by Joseph S. Miller, formerly Commissioner of International Revenue under Cleveland's administration, will build an electric line from Washington, D. C., to the falls of the Potomac, a distance of twenty miles. The road will be one of the finest in the country and will cost \$3,000,000. The work of surveying and securing the right of way will begin this week.

The Aldermen have granted to the New York City Interborough Railway Company franchise rights for thirty-six miles of new tracks in The Bronx, including the use of four bridges. The city is to receive as rental 3 per cent. of gross earnings for the first five years and 5 per cent. thereafter. The minimum annual rental after five years will be \$30,000. A separate rental of the bridges will bring in \$6,000 a year.

The demand for the new turbine engine of the General Electric Company is assuming large proportions, and it is expected that within a short time the facilities for turning out the engines will be insufficient to meet orders. It is stated that the eagerness of manufacturers to replace their old engines with the new turbine need not be wondered at, as the turbine will produce the same quantity of power with 30 per cent. less fuel.

Alexander Brown, of Alexander Brown & Sons, the prominent bankers of Baltimore; H. J. Bowdoin, of the Maryland Trust Company of Baltimore, George H. Frazier, of Brown Brothers & Company of Philadelphia; S. L. Shoerber, Jr., and W. L. Thompson, also of Philadelphia, have been in Pittsburg inspecting the traction properties of the Philadelphia Company. It is rumored that Standard Oil interests are seeking control of

the Philadelphia Company, but officers of the latter company denied that such a deal was in contemplation. They further said that the visitors were making an inspection of the traction lines to see what necessary improvements should be made.

The reorganization of the Albany & Hudson Railway and Power Company has been accomplished. The new name of the road will be the Albany & Hudson Railroad Company, and its capital will be \$2,000,000. The directors are as follows: H. G. Runkle, A. M. Young, Henry Siebert, F. M. Voorhees, W. F. Sheehan, R. A. C. Smith, of New York; C. L. Rossiter, Seth L. Keeney, of Brooklyn, and Horace E. Andrews, of Cleveland, Ohio.

At the annual meeting of the stockholders of the Union Traction Company of Indiana, held at Anderson, Ind., final steps were taken for the merger of the company's lines with those of the Indianapolis Northern Traction Company, connecting Indianapolis with Peru and Logansport. This gives the combined companies a capital of \$9,600,000, and 450 miles of electric interurban trackage connecting the principal cities of central and northern Indiana.

The \$200,000 forty-year 4½ per cent. gold bonds of the Louisville (Street) Railway Company have been sold to the Fidelity Trust Company at 104.982. A similar block, sold last spring, brought 108. The directors, after awarding the bonds, declared the regular dividend on the preferred stock of 2½ per cent., payable April 1, and 1¼ per cent. on the common. The dividend on the common is payable quarterly, and on the preferred semi-annually.

The Hudson & Manhattan Railroad Company has been incorporated with a capital of \$3,000,000 to construct a tunnel from Broadway and Cortlandt street, under the Hudson River, to the New Jersey State line opposite a point between Liberty and Fulton streets, there to connect with a railroad corporation organized under the laws of New Jersey and extending westerly to Jersey City. The length in New York State is one mile. Directors are: George P. Lester, Bloomfield, N. J.; Howard Slade and James Davidson, Manhattan; Clinton Graham, Flushing; Abraham Proctor, Jr., Boonton, N. J., and Adolph F. Reichter, Brooklyn.

The Kanawha Water & Light Company, of Charleston, W. Va., has been organized here with a capital of \$1,000,000, under a charter which authorizes the increasing of the stock to \$2,000,000. The company purposes to buy gas, electric lighting, water and street railway franchises in Charleston at the cost of \$600,000. Officers were chosen at the meeting as follows: President, Richard Elkins, of

Washington; secretary and treasurer, W. F. Sadler, Jr., of Trenton, N. J. The following directors have been elected: Senator Stephen B. Elkins, Richard Elkins and Colin H. Livingston, of Washington; W. F. Sadler, Jr., and State Senator Charles W. Swisher, of Fairmount, W. Va.

The Maryland Telephone and Telegraph Company has recorded a general mortgage in favor of the Central Trust Company to secure the issue of \$4,000,000 of 50-year 5 per cent. gold bonds. Of the issue, underwritten by a syndicate organized through the Central Trust Company, \$1,155,000 will be used to liquidate the floating debt of the company. An additional \$1,000,000 will be reserved to take up the old issue of bonds of that amount now out when they become due.

As a result of this consolidation the above company now owns or controls all the developed water powers near Montreal, together with all distributing systems in the city, and in fact, on the entire island. The company also controls all the gas and electric business of the city and serves a population of about 350,000. It is estimated that when the plans of the power company are completed, the total water power development will be nearly 75,000 horse power.

The directors of the Louisville Gas Company have approved the merger of the Louisville Electric Light Company and the Citizens' Lighting Company. The new company will be called the Louisville Lighting Company and will issue \$6,000,000 securities for those of the absorbed companies, of which \$3,666,700 will be paid for the Louisville Electric Light Company and \$2,333,300 for the Citizens' company. Payment will be about half in stock and half in 5 per cent. 50-year gold bonds.

It is announced that the Montreal Light, Heat & Power Company has sold to the Bank of Montreal and N. W. Harris & Company, bankers, New York, an issue of \$4,000,000 thirty-year 5 per cent. bonds to pay in part for the Lachine Rapids Hydraulic & Land Company, Limited, and its two affiliated companies, i. e., The Standard Light, Heat & Power and The Citizens' Light, Heat and Power Company. The new bonds will be the obligation of the Montreal Light, Heat and Power Company, and will be additionally secured by a lien on all newly acquired properties. The capital stock will be \$17,000,000.

At a meeting of the Detroit United Railway Company directors, held February 21, it was decided to make an expenditure of over \$400,000 for new equipment, which will include a half dozen new suburban cars, over \$30,000 worth of new wire to better distribute the electric current, an additional order for

new double-track cars and various other items of minor importance, but all tending to improve the condition of the road. Chairman Henry A. Everett, at the conclusion of the meeting, stated that the directors gave the matter of constructing a new line from Flint to Inlay City some consideration, but no decision has as yet been reached, and the project was referred to Mr. Hutchins, one of the directors, for further investigation.

A new electric power plant is likely to be established at Detroit, probably in opposition to the Detroit Edison Company. The new concern will be formed with \$800,000 capital. Its alleged purpose is to manufacture cement, but this, it is believed, will be but a by-product. The particulars are so carefully guarded that not even the name of the company has been divulged. It is known, however, that the following directors have been elected: Justus S. Stearns, Arthur Pack, Abraham Jacobs, Homer Warren, G. Duff Stewart, W. G. Malcomson and T. H. Wagner. It is rumored that the organization is to construct an immense electric light and power plant, using the Eastern Electric Light Company and its branches as a nucleus.

The Electric Storage Battery Company reports for the year ended December 31, 1902: Net earnings, \$1,113,199; increase, \$213,199; less dividends, \$812,427; increase, \$14; surplus, \$300,772; increase, \$212,943; previous surplus, \$2,022,582; total surplus, \$2,323,354; increase, \$300,772. The stockholders at their annual meeting ratified the sale of the Derby Lead Company for \$542,282, which was authorized by the directors on June 5, 1902; also the purchase of 44,000 shares, securing control of the Chloride Electrical Storage Syndicate, Limited, of London, authorized by the directors October 2, 1902. President Lloyd stated that the company was bringing over from last year orders aggregating \$1,000,000. The retiring directors were re-elected.

The Little Rock Traction & Electric Company and the Little Rock Edison Electric Light & Power Company have passed into the possession of the banking firm of Isidor Newman & Son, of New Orleans and New York. The capital stock of the company is \$500,000 and the total valuation of the property is as follows: Cash value real estate, \$69,000; cash value personal estate, \$218,000; cash value of credits, \$9,122; total valuation, \$296,122. The debts are as follows: First mortgage, \$410,000; second mortgage, \$200,000; floating debt, \$330,464; total indebtedness, \$940,463. The United Securities Company of Boston disposed of all of its interests in the property, about two-thirds, while the General Electric Company practically controls the rest. Judge W. E. Hemmingway will continue as president of the local organization.

The merger of the Union Traction Company and the Indianapolis Northern has not yet been completed, because of the injunction suit of the minority stockholders of the Union Traction Company pending in the Superior Court. The stockholders, both common and preferred, of the Union Traction Company, are to participate in the distribution of the Indianapolis Northern stock as well as in \$370,000 preferred stock in the treasury of the Union Traction Company. At a meeting of the Union Traction Company, the old directors and officers were re-elected. The report showed total receipts for the fiscal year of \$962,255; expenses, \$516,503 and charges, including dividends on preferred stock, \$329,090, leaving net profit of \$115,671.

Contracts aggregating \$2,000,000 have been awarded by the Interborough Rapid Transit Company, which will operate the underground railway, for the electrical equipment of the road. The General Electric Company secured the order for the controlling apparatus, which is substantially identical with that in use on the Manhattan Railway, and the Westinghouse Electric and Manufacturing Company will supply the motors. When fully equipped the Manhattan-Bronx line will use 600 cars, which will be run in trains of from three to six cars each. On each car will be two motors, so that they can be used interchangeably for express and local service. The equipment, it was announced, will not be delivered until a short time before the completion of the work of construction.

It is estimated that capitalists of Cleveland who are interested in electric traction will this year spend \$20,500,000 in new construction. The projected extensions when completed will connect Cleveland with Buffalo, Pittsburg, Chicago, Toledo, Cincinnati, Youngstown, Canton and all intermediary points. These extensions will involve the laying of 600 miles of steel rails, at a cost of \$18,000,000 for material, labor, franchises, right of way, etc. The estimated cost of rolling stock to equip the lines is \$2,500,000. The scarcity of labor and material is expected to be a drawback to rapid progress. Work on the Mansfield and Ashland line will be started immediately, and at the same time work will begin on the Western Ohio Traction Company's extensions. Work on a stretch of track from Sidney to Findlay will begin at once, and will be pushed energetically.

Shareholders of the Union Switch & Signal Company held their annual meeting in the office of George Westinghouse, who presided. Mr. Westinghouse said that the management was considering an increase in the capitalization of the company to pay off the bonded indebtedness, provide capital for the growing business and to devote more of the

earning to dividends. Mr. Westinghouse was re-elected president and George G. Smith, James H. Willock, William McConway, Robert Pitcairn and Thomas Rodd were re-elected directors, H. C. Prout being elected a director in the place of Frank Moore, resigned. At their meeting after the stockholders adjourned the directors declared a dividend of $2\frac{1}{4}$ per cent. on the preferred and $1\frac{1}{2}$ per cent. on the common stock for the quarter ending April 1, checks to be mailed April 10. Transfer books close April 1 and reopen April 11.



E. A. Wurster, secretary and treasurer of the Falk Company, has closed a contract with the Cincinnati, Milford & Loveland Traction Company for the building of an interurban electric railway from Cincinnati, through Milford, to Loveland, Ohio. The deal involves about \$1,000,000. Work upon the contract will begin at once, and the local firm will employ from 600 to 1,000 men. The engineering crew and the experts of the company will leave next week to arrange the preliminary work. The new line will be about $33\frac{1}{2}$ miles long and the contract provides for the completion of the road from Cincinnati to Milford, a distance of 14 miles, by July 1. A contract to the Carnegie Company for the material necessary for the line has already been awarded. The line will be equipped with the overhead trolley system, and the power will be furnished from a power house at Milford, Ohio.



A certificate incorporating eight South Jersey gas companies under the name of the South Jersey Gas, Electric and Traction Company was filed at Trenton on February 28th. The consolidated company has an authorized capital stock of \$6,000,000, and is to issue \$9,000,000 bonds for the retirement of stocks and bonds of the merged companies. The following companies are said to be included in the deal: The South Jersey Gas, Electric and Traction Company, River Shore Gas Company, Burlington Gas Light Company, Bordentown Gas Light Company, Gloucester City Gas Light Company, Suburban Improvement Company, Camden Gas Company, Stockton Electric Light and Power Company and the Beverley City & Township Gas and Water Company. Anthony R. Kuser, of Trenton, is president of the new company; William J. Bradley, of Camden, vice-president; Forrest F. Dryden, of Newark, secretary, and Charles G. Cook, of Trenton, treasurer.



The report that General Electric interests again are buying National Carbon common shares has elicited further comment on these acquisitions, which, it is said, have been going on in a quiet way for more than a year. The great future of the company is said to promise much for the junior shares, and

those who pretend to know all about current affairs and future intentions of the management, say that the ensuing year will bring forth great results, both in the way of new ventures contemplated to widen the company's field and earning capacity, as well as results from splendid physical condition of the plants, rendered so by continued expenditures out of earnings during the last four years. Among many new departures in which the company is now branching out, the carbon business is by no means being neglected. On the contrary, it is said, many improvements have been made, not only in the economy of manufacture, but in the durability of carbons, the latter being an advantage to the consumer. It would naturally be supposed that longer life of the carbon would not be an argument in favor of the company, but it is explained that the cheaper cost of manufacturing the new product will more than offset this. The company is fortified with patents on its new process, and prices will be upheld.



The monthly circular of D. Houston & Co. on the copper market presents these arguments for continued prosperity of the industry:

"As to the future of the market, the indications at present appear to favor not only a retention of the gains made, but the probability of a further advance. Prices for a good part of last year were not regarded sufficiently profitable to many of the companies engaged in the industry of mining copper to warrant a policy of adhering to market the metal at an abnormally low level. The facts showed that trade requirements for copper were on an unprecedented scale of magnitude last year, and the reasonable conclusion seems to have been reached that copper ought to command better prices than those ruling in 1902. If the market can be preserved from unsettling influences, which would also serve to protect consumers from sudden and serious disturbances, current trade conditions and expected 1903 requirements should be able to furnish the necessary requisites for maintaining a steady tone.

"We believe that the developments bound to occur in the next ten years in the field of electrical and other industrial expansion necessitating the free use of copper will be such as are likely to exceed the conception, at this day, of even the most optimistic and clear-sighted student of the situation. The future can be measurably read in the light of the past, and the history of the last ten years, with the phenomenal advancement which has been crowded into them along electrical, industrial and commercial lines, should assist in enabling people to obtain a vision—dimly outlined, perhaps, but none the less certain—of coming possibilities. While, therefore, the importance of an increasing copper production is apparent, it is none the less reasonable to expect that the consumption of copper five and ten years hence will greatly outstrip that of the present time."

LIBRARY
OF THE
UNIVERSITY of ILLINOIS

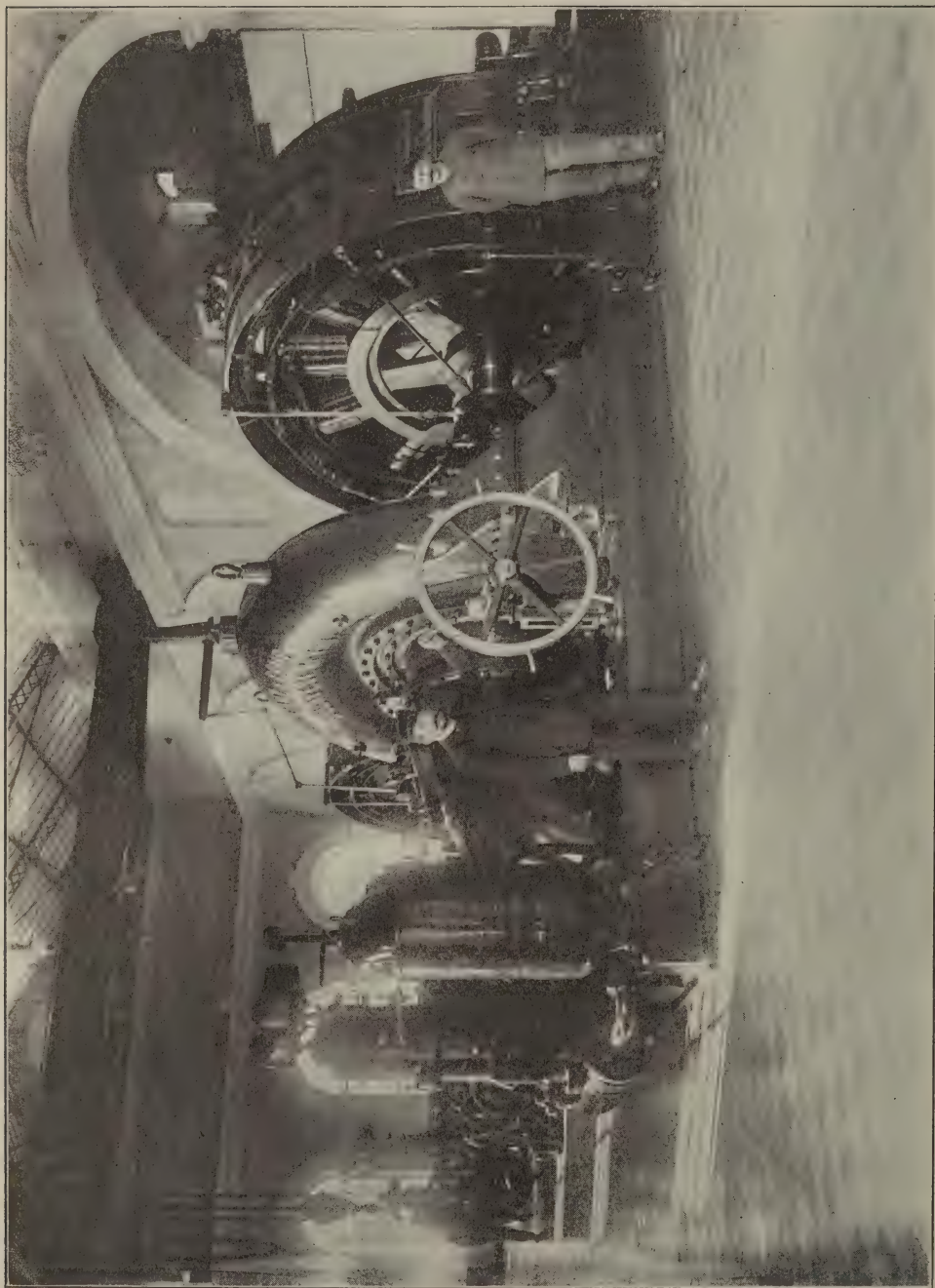

Interior View of the Morbegno Power House of the Valtellina Railway, Italy.

THE ELECTRICAL AGE

NEW YORK

VOL. XXX

MAY, 1903

No. 5

Central Power Stations at Iron and Steel Plants

By FRANK C. PERKINS

IN installing a modern electric power plant for iron and steel works it is generally conceded that the most economical equipment is that which will utilize the waste gases from blast furnaces. The power is supplied by steam engines, the boilers being first by the blast furnaces, or by blast furnace gas engines using the waste gases direct, the latter requiring only about one-quarter the combustible of the former, at the same time doing away with costly boilers and expensive wear and tear. In many plants extensive steam generation is necessary for operating the enormous high-power, reversible rolling mill engines, and here the waste gases are used to great advantage.

A blast furnace having a capacity of 100 tons of pig iron every 24 hours produces 7,000,000 cubic feet of gas daily,

equivalent to 2,800 horse power. If we deduct the power to drive the furnace proper, there remains 2,000 horse power, which until recently was entirely wasted.

It must be acknowledged that European engineers are far in advance of their American brethren in the design and construction of large blast furnace gas engines for driving electrical generators and blowers in the great steel and iron plants of the world. Even the largest steel plant in the world, now under construction at Stony Point, Buffalo, N. Y., is to utilize foreign designed blast furnace gas engines of from 35,000 to 40,000 horse power, although they are to be constructed in this country by representatives of a German firm.

Electricity is being used more and more in every department of the pro-

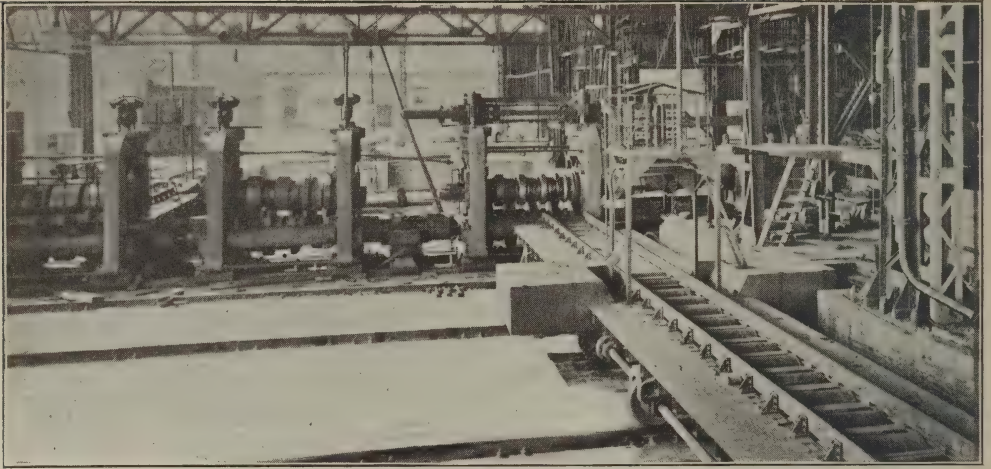

Electrically Controlled Rolls and Transfer Table.

duction and manufacture of iron and steel. The immense central power plants at the best designed works generate current—both alternating and direct currents being employed—the power being transmitted to the power-consuming centers, which are frequently from three-quarters to a full mile distant from the power house.

When it is considered that the blast furnace gas engine is applied to generating electricity, which holds a dominating position in so many branches of industry, it is very easy to see that no other motive power can be compared to this combination from an economical point of view. Too much attention cannot be given this new source of energy, for it is likely to rival steam in this work.

The iron and steel industry has had an unprecedented growth in the past decade, and every means is utilized to handle the ore with the greatest economy in mining, loading, and unloading, as well as the charging of the furnaces, operating the rolling mills, and producing the finished products at the lowest possible expense.

Electricity plays an important part in the operation of all of the labor-saving machinery. Economy is the watchword throughout a modern steel plant. Gas engines using the waste products from the furnaces supply the energy for the current required; there is increased economy in the electrical ore-handling machinery, and in the conveying of coke and ore, as well as of the iron and steel.

The methods employed are similar throughout Germany and other European countries, as well as in America. The Lackawanna Steel and Iron Company, of Pennsylvania, was incorporated a short time ago, with a capital of \$25,000,000, and a new steel plant was started at Buffalo, N. Y., to have an annual output of 800,000 tons of finished Bessemer product in steel rails and billets. The finest electrical equipment of any similar plant in the world was designed and is now being installed. In constructing this plant the engineers have gone far beyond what was expected when first contemplated. Another charter was taken out for the Lackawanna Steel Company, of New York, with a capital of \$40,000,000, and the

Pennsylvania corporation is now owned by the New York corporation. The engineers are now arranging to install an open-hearth plant for the manufacture of structural iron and plates, having an annual output of nearly 500,000 tons more, making a total output of 1,250,000 tons of iron and steel per year. This addition means an increase of plant all along the line, more coke ovens, blast furnaces, gas engines, generators, and a larger plant in the coal fields.

There is now under construction a concrete ore dock 280 feet wide and nearly a mile in length, running along the canal from the lake back into the steel works, and the latest types of electrically operated coal, coke and ore conveying apparatus are to be installed. The Wellman-Seaver-Morgan Engineering Company, of Cleveland, are installing much of the electrically driven labor saving machinery in this plant.

The central power station will supply both alternating current at 440 volts and direct current at 250 volts for use about the plant, a number of 500-kilowatt generators of each type being employed. These dynamos are to be driven by eight enormous Korting blast furnace gas engines of a maximum capacity of 1,000 horse power each. There are to be sixteen of these internal combustion engines of 2,000 horse power each in operation for driving the dynamos and blast furnace blowers. These engines are to be constructed in this country by the De La Vergne Refrigerating Machine Company, of New York, who are the American representatives for Gebr. Korting, of Kortingdorf, near Hanover, Germany.

The double working 700 horse power Korting blast furnace gas engine for Walzwerkbetrieb at the Dusseldorf Exposition was constructed by the Maschinenbau-Aktiengesellschaft, formerly Gebr.

Klein, of Dahlbruch. It has a speed of from 85 to 90 revolutions per minute, the stroke being 1,300 millimeters long and the cylinder diameter 750 millimeters. There is a 500 horse power engine of this type for Geblasebetrieb at the Niederrheinischen Hutte of Duisburg-Hochfeld, and another of the same capacity driving an electrical generator at the power house of the Gutehoffnungshutte at Oberhausen.

A Korting 350 horse power engine of this kind was tested by Herr Meyer, showing a mechanical efficiency of 71 per cent.; the mean power indicated in the motor cylinder being 544 horse power; the mean power indicated in the pumps was 63 horse power; the effective indicated horse power for the engine being 481 horse power. The mean power on the brake was 341.5 horse power, the speed being 101 revolutions per minute. The consumption of gas per brake horse power was 81.5 while the thermal efficiency was 23.8 per cent.

The engine is of the two-cycle type, and has one motor cylinder, double acting like a steam engine, with a piston rod and cross head working through guides and a crank. The discharge of burnt gases is through the ports and through an annular passage around the middle of the cylinder, which is uncovered by the piston. The length of the double acting piston is equal to the stroke, less the width of the exhaust ports. The gas and air enter the admission valves by separate pipes from two double acting pumps, both driven by an auxiliary crank 110 degrees in advance of the motor crank.

The 500 horse power Korting double acting gas engine operates at a speed of 100 revolutions per minute. It has a total weight of 70,000 kilograms, including the flywheel, and of 58,000 kilograms without the flywheels. The stroke of

this engine is 1,100 millimeters, and the diameter of the cylinder is 635 millimeters.

Among the numerous systems of blast furnace gas motors used in central power stations for operating electrical generators and blowing engines in iron and steel plants, may be mentioned the Oech-

a simple cylinder, open at both ends. These pistons, shortly before reaching their dead points; open successively the different ports; first the exhaust port, then the port for rinsing the cylinder with fresh air, and lastly the gas inlet port.

At first such a quantity of burned

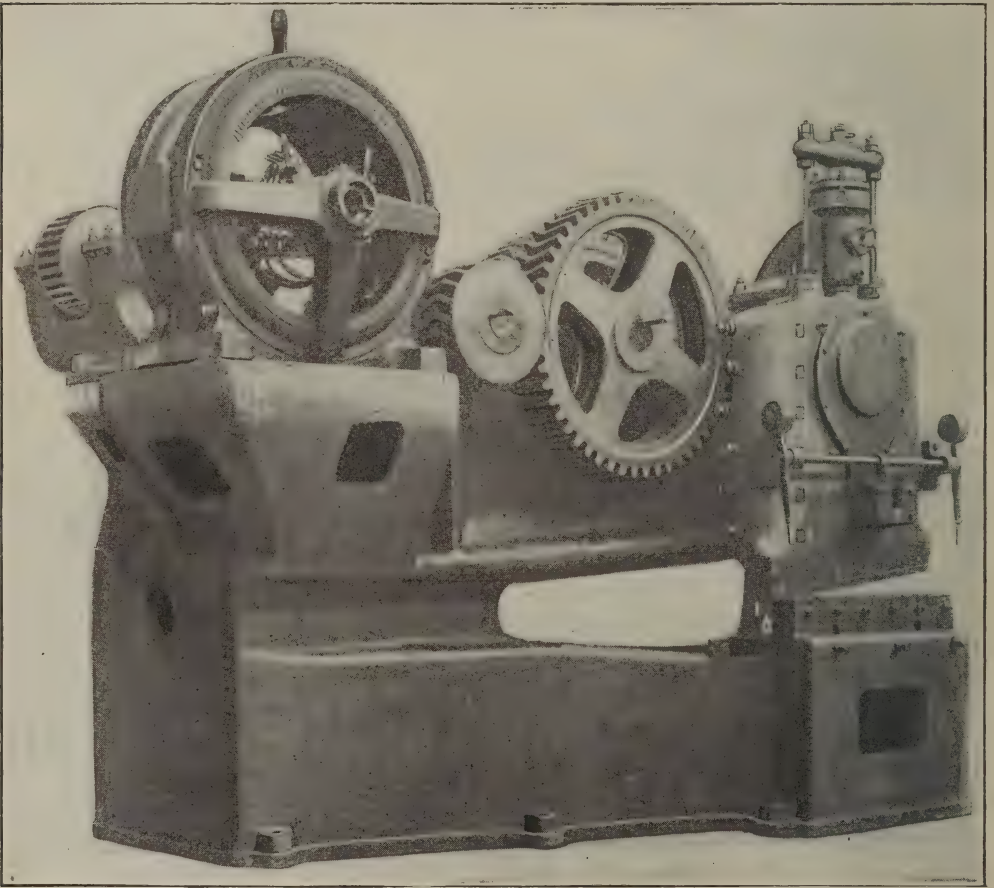

Electrically Operated Shearing Machine.

elhauser two-stage motors. Gas engines of this type have been constructed of 600 horse power capacity and over by the Kolnische Maschinenbau-Actien-Gesellschaft of Koln-Bayenthal.

The principle underlying the construction of this type is that of two plunger pistons working toward each other in

gases escapes that the pressure in the cylinder sinks to that of the atmosphere, the entering fresh air then blowing out the rest of these gases through the exhaust pipe. Thus a yielding cushion is formed between the hot exhaust gases and the fresh ones before the fresh supply of gas enters and mixes with the in-

coming air, forming the explosive mixture. This mixture is compressed by the two pistons nearing each other, and is ignited for explosion shortly before the end of the compression, thus driving the pistons away from each other and reversing their motion as before.

The air and fresh gas are supplied by a feed pump attached to the motor and are compressed in the receivers around the inlet ports to such an extent that a sufficient rinsing of the cylinder is effected, as well as a good mixing of fresh gas and air. In regulating the gas supply to the pump by a simple admission valve the number of revolutions of the engine can be accomplished in the same manner as with steam engines, by means of the throttle. The cylinder itself has no valve operating during the piston stroke, and the engine is thus of very simple construction. The working cylinder is arranged in a horizontal line in such manner that it may expand freely without any alteration of the cylinder's center in relation to that of the blowing cylinder when used for this purpose.

At the electrical power generating plant of Gebr. Rochting Huttenwerk, at Volklingen, a 600 horse power tandem blast furnace gas engine is employed. It operates at a speed of 120 revolutions per minute, and was constructed by the Vereinigten Maschinenfabrik, Augsburg, und Maschinenbau-Gesellschaft, Nurnberg.

It drives an alternator of the three-phase type by direct connection, supplying current for the transmission of power about the works; the pressure used is 450 volts.

At the Dusseldorf Exposition a 350 horse power double cylinder gas engine was shown by Louis Soest & Co., m. b. H. Maschinenfabrik und Eisengiesserei, of Rieselholz, near Dusseldorf. This engine has a flywheel weigh-

ing 26 tons mounted between the two cylinders, each of which has a diameter of 650 millimeters. The stroke of this blast furnace gas motor is 850 millimeters and the normal speed is 140 revolutions per minute. It is designed for driving a three-phase alternating current generator in the power house of a steel and iron plant, and weighs 150,000 pounds, complete.

The Soest 600 horse power double cylinder gas motor for operation by furnace gases operates at a speed of 120 revolutions per minute, and weighs, excluding the flywheel, 82,000 kilograms.

The high power blowing engine shown by the Gutehoffnungshutte of Oberhausen II. is directly connected to a 1,200 horse power Deutz blast furnace gas engine whose stroke is 30 inches, the two air cylinders being 34 inches in diameter. The engine operates at a speed of 135 revolutions per minute, taking 1,000 cubic meters—or 33,500 cubic feet—of air and compressing the same to .5 of an atmosphere. The engine is fitted with regulating gear whereby it is possible to compress the air to a pressure of .75 atmosphere with the same motive power but with altered aspiration. The discharge of air is effected by return valves of the Stumpf type and the admission by means of cylindrical valve motion.

A central power station of 5,000 horse power, equipped with six blast furnace blowing engines and three gas engines using waste blast furnace gases, driving electric generators, is operated by the Société Anonyme de Hauts-Fourneaux, Forges et Charbonnages d'Eifferdange, Dennenbaum (Grand Duché du Luxembourg). The engines are of the Delmare-Deboutteville and Cockerill system and were constructed by the Société Anonyme John Cockerill of Seraing, Belgium. The nine Cockerill blast furnace

gas engines at Differdingen each have a capacity of 600 horse power, consuming 2.9 cubic meters of gas per horse power per hour.

The three electric generators driven by the 600 horse power gas engines supply current for motors and lights about the works, the six blast furnace blowing gas engines serving the four blast furnaces. The amount of dust which the blast furnace waste gases contains is greatly reduced by a cleansing process consisting of a gas washing installation. By means of this apparatus the gas enters the engines with but a small proportion of the dust coming from the furnace. The diameter of the gas engine cylinder is 1.3 meters and the length of stroke 1.6 meters, while the speed is 80 revolutions per minute. The air cylinders are 1.7 millimeters in diameter and the volume of air taken is 500 cubic meters per minute.

The electric power plant of Schneider & Cie, at Creusot, consists of three electrical generators direct connected to 200 horse power Cockerill gas engines. In this plant there are also in operation several 600 horse power gas motors of the same type using blast furnace waste gases, driving directly large blowing engines.

The tandem blowing engines of the Cockerill type installed at the power plant of the Roehlingsche Eisen und Stahlwerke, at Diedenhofen, Lorraine, each have a capacity of 1,200 horse power, and a complete electric central station has been designed by the Société Anonyme John Cockerill of Seraing with four double tandem blast furnace gas engines direct connected to electrical generators, each of 2,500 horse power capacity, and having a total output for the plant of 10,000 horse power.

The enormous plant of the Ougree-Marihaye Blast Furnace Iron Works Company is already equipped with an

excellent electric power transmission installation. The power house is equipped with two Delamare-Deboutteville horizontal double working gas engines utilizing waste blast furnace gases; directly connected to these engines are two 600 horse power direct current generators of the multipolar type, built by the Compagnie Internationale d'Électricité, of Liege, Belgium. There is also in operation at this plant a 150 horse power unit and provision is made for 3,000 horse power, a large 1,200 horse power Cockerill gas engine and dynamo being under construction. This iron and steel plant employs about 6,000 men, and the rolling mills are equipped with electric motors which drive the auxiliary rolls; one of the main rolling mill engines, having a capacity of 10,000 horse power, is a reversible steam engine.

The 2,500 horse power electrical generators and double gas engines designed by the Société John Cockerill for iron and steel plants and their central power stations, utilize the waste blast furnace gases the same as the smaller types. These units consist of double tandem engines with double acting cylinders, the speed being 100 revolutions per minute. The cylinders are 1.2 meters in diameter; stroke, 1.2 meters. Two of these engines connected together on the same shaft would produce a 5,000 horse power unit, and could be used to operate a tri-phase alternator, the combined regulation and turning moment being probably satisfactory.

In a report of the test of a Cockerill blast furnace gas engine made by H. Hubert, Chief Inspector of Mines and Professor at the University of Liege, Belgium, he states that the expenditure of gas per effective horse power per hour was 3.113 cubic meters, suppressing at the time 6 admissions upon 84 revolutions, which was equivalent to 14 per

cent. He states that on the afternoon of the day on which the test was made, the motor was able to develop during several consecutive hours nearly 900 indicated horse power and to produce a useful work of 725 horse power with an expenditure per effective horse power per hour of 2.853 cubic meters with a gas having at constant volume a calorific value of about 1,000 calories per cubic meter. This result was obtained by running the engine under full load.

This engine had a normal compression of 9.5 kilograms per square centimeter, a piston stroke of 1.4 meters and a diameter of cylinder of 1.3 meters. The piston rod was 244 millimeters in diameter, while the shaft measured 460 millimeters in diameter. The engine is 11 meters long, 6 meters wide and 4 meters high, weighing, including a flywheel of 33 tons, a total of 127 tons.

In English iron and steel works, as well as those in America, the steam engine has up to the present time been most extensively used in the central power houses, where electrical transmission has been found most practical. The blast furnace gas engine will now, no doubt, be extensively introduced into both countries.

At the electrical power house of the Park Gate Iron and Steel Company, 200-kilowatt Westinghouse direct current generators and direct connected engines are employed. The generators supply a continuous current at 250 volts and the motors are used for operating rolls, cranes, shears, and locomotives.

The main power house of the Antwerp Iron and Steel Works will eventually have a capacity of 30,000 horse power, which will be electrically transmitted about the works for motor supply as well as lights. The present plant consists of steam engine driven generators, the marine triple expansion engines each hav-

ing a capacity of 1,500 horse power. The high pressure cylinder measures 22 inches in diameter, the low pressure 46 inches, and the intermediate, 32 inches. The engines are direct connected to three-phase Westinghouse generators of 900 kilowatts capacity, operating at 2,200 volts; the speed is 187 revolutions per minute, and the frequency 50 periods per second. The generators are of the rotating field type. A gas driven installation is also about to be made.

Polyphase plants are operated extensively for transmission in steel plants in Europe as well as in America. At the Huttenwerk Karlsruhe, near Diedenhofen-Lothringen, the power house is equipped with 600 horse power three-phase machines, operating at a speed of 120 revolutions per minute. The gas engines were built by the Vereinigten Maschinenfabrik Augsburg und Maschinenbaugesellschaft Nurnburg A. G., and are of the tandem type, with cylinders of 900 millimeters diameter. The stroke is 1,000 millimeters long, and the flywheel has a diameter of 6.4 meters.

The power plant of the Minnequa Works of the Colorado Fuel and Iron Company, at the city of Pueblo, utilize furnace gases for firing the 3,600 horse power Babcock & Wilcox boilers, as well as the Cahall vertical boilers of a total capacity of 16,000 horse power. The electrical power generating plant consists of a building 214 feet long and 50 feet wide, equipped with three Allis-Corliss engines of the cross compound horizontal type, direct connected to 500-kilowatt Westinghouse direct current generators. There are also two 400 kilowatt units, consisting of horizontal cross compound engines direct connected to Westinghouse alternators. The engine and generator room is served by a 25-ton Shaw electric traveling crane. The steam for this plant is supplied from an independent

boiler plant of 2,000 horse power capacity, consisting of water tube boilers. The water is cooled by a Worthington fan cooling tower and Worthington surface condensers are employed, the pumps being built by the Snow Steam Pump Works. The pumping plant for the entire works is 114 feet long and 50 feet wide, and the building is supplied with a 15-ton Shaw electric crane. Five Snow cross compound horizontal pumps are installed, two of which have a capacity of 5,000,000 gallons each, and the remaining three, 7,000,000 gallons each. These pumps—of a total capacity of 36,000,000 gallons—have duplicate connections to a stand pipe 150 feet high and 18 feet in diameter. Electric power is used very extensively throughout the entire works.

The above power plant is typical of electrical generating stations at iron and steel plants throughout the United States. In Canada electricity is being very largely employed at the Dominion Iron & Steel Company's plant, at Sydney, Nova Scotia. Series and shunt

wound multipolar direct current motors of both General Electric and Westinghouse types, ranging up to 100 horse power capacity, are used. A 40 horse power motor supplies power for conveying the crushed coke to the top of the elevator at the coke ovens, and a 75 horse power motor operates the coal crusher. At the washing plant two 75 horse power motors are used for crushing the lump coal and conveying it to the shaker screens. A number of other 30 horse power motors pump the water for washing the coal, operate the shaking screens, run the jigs and convey the dirt out to the dump; while several 15 horse power motors convey the washed coal to the tops of a series of elevators.

The motors are also used for charging the coke ovens, operating the scale cars, and other machinery at the furnaces, as well as in the open hearth building, the blooming mill and the machine and repair shops. Electricity is playing an important part in every modern iron and steel plant throughout the world.

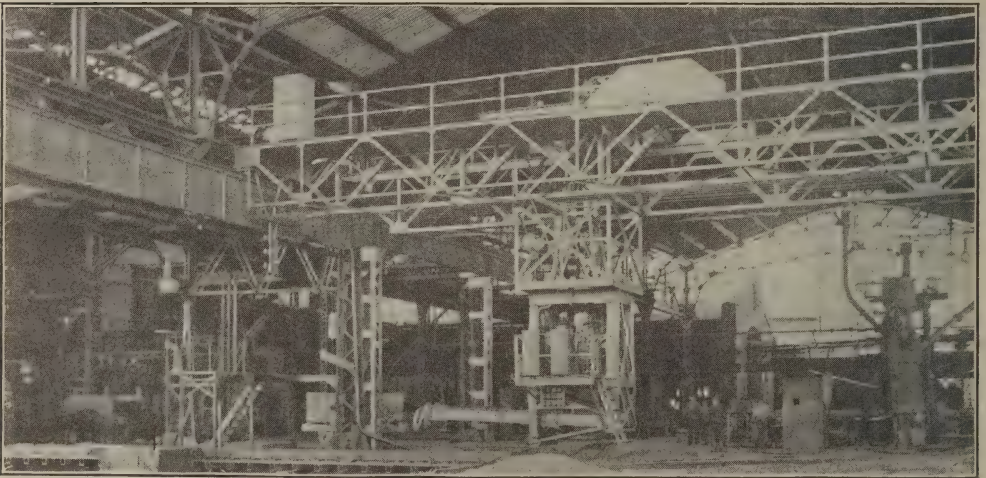

Electrically Driven Charging Crane

The National Bureau of Standards at Washington, D. C.

By S. W. STRATTON, Director

THE work for which the National Bureau of Standards—which, according to an act of Congress approved March 3, 1901, superseded the office of Standard Weights and Measures of the Treasury Department on July 1, 1901—was established includes research and testing in the domain of physics, extending into the field of chemistry on the one hand and of engineering on the other. The union of research and testing in one institution is of supreme importance, the investigations being, of course, primarily designed to carry the work of standardization and testing to the highest possible efficiency. The Physikalisch-Technische Reichsanstalt of Germany is an illustrious example of how much can be accomplished where research and testing are combined in one institution. The laboratory requirements are, therefore, those of a research laboratory plus whatever special facilities may be needed for commercial testing. Two buildings have been planned, one of which, the mechanical laboratory, is now under construction, and the plans for the other are completed. The latter, which is called the physical laboratory, will provide for that part of the experimental work which ought to be kept free from mechanical and magnetic disturbances, and to this

end will contain scarcely any machinery. It will also contain the offices for administration, the library, and a well-equipped chemical laboratory. The mechanical laboratory contains the mechanical plant, instrument shop, and laboratories for the heavier kinds of experimental work where considerable power or large currents are required. The two buildings are to be connected by a spacious tunnel, through which air ducts, steam, gas, and water pipes, and electric circuits are carried from the mechanical to the physical laboratory.

A laboratory has been fitted up for the verification of standards of resistance and electro-motive force, in terms of which all electrical measurements will be directly or indirectly expressed. A large number of resistance standards, ranging from 0.0001 to 100,000 ohms, have been secured and suitable comparing apparatus has been acquired, so that the bureau is already equipped for the measurement of resistance standards submitted for verification in terms of those belonging to the bureau to the highest order of accuracy.

The international unit of resistance, legalized by act of Congress in the United States, was defined by the International Electrical Congress in terms of the resistance of a column of mercury of

specific dimensions at a specified temperature, and it was assumed that the various governments represented would take up without delay the construction of new mercurial standards. While the use of secondary standards for ordinary purposes suffices, it is most important that the bureau should undertake the construction of primary mercurial standards at the earliest possible moment, not only to place the resistance measurements on a firmer basis, but also to determine, in conjunction with the laboratories of other governments, the accuracy with which such standards may be reproduced from their definitions, and to construct a number of secondary mercurial standards, as such standards after aging are not subject to as large variations as wire standards.

Facilities are now provided for the verification of resistance boxes, ratio coils, potentiometers, and other classes of apparatus, and facilities are to be provided for the calibration of low-resistance standards of high carrying capacity, for the determination of specific conductivity and insulation resistance.

During the past year a considerable number of resistance standards have been verified for manufacturers, scientific institutions and the Government.

Accurate measurements of electro-motive force are as fundamental as the accurate measurement of resistance. A number of Clark standard cells, legalized by Congress as the standard of electro-motive force in the United States, have been constructed from chemically pure materials obtained from a number of different sources, and also from the same materials subjected to further purification. Although the agreement of the individual cells with each other is within two parts in 10,000, a further supply of materials for new cells has been purchased. This material will be analyzed

and subjected to further purification in order that the standards of electro-motive force may meet every requirement.

When the unit of electro-motive force was defined by the International Congress the best determinations of the value of the Clark cell in terms of that unit corresponded to the relation 1 volt equals $1000/1434$ electro-motive force of the Clark standard cell at 15 degrees C. Subsequent work has indicated that the volt thus defined is too small by almost one part in 1,000. A different unit has therefore been adopted by Germany. Moreover, another type of standard cell, the Weston, has been found to possess some advantages over the Clark cell. A number of these cells have already been set up, and, in view of the possibility of its adoption as the official standard of reference, others are to be constructed and compared with each other and with the Clark standard cells.

One of the temporary laboratories has been fitted up for the calibration of voltmeters and ammeters, and while the range is at present limited to 150 volts and 50 amperes, apparatus will soon be installed for increasing these ranges to 2,000 volts and 1,500 amperes. The necessary galvanometers, resistance standards, resistance boxes, regulating rheostats, and other accessory apparatus have been provided. A comparative study of the different makes of American instruments will be made after the working standards of the bureau have been calibrated. Facilities will also be provided for the measurement of ammeter shunts of high carrying capacity. A number of requests for work of this kind have already been made. With facilities for the measurement of high voltages and heavy currents, the bureau will also be prepared for the verification of direct-current wattmeters and supply meters,

and this work will be undertaken for the public as soon as an adequate force is provided.

An alternating-current laboratory is being fitted up at 235 New Jersey avenue SE. A storage battery for furnishing direct current for experimental work and for power has been installed. Orders have been placed for specially designed single-phase and multi-phase alternators, to be direct connected to independent direct-current motors. Especial attention will be given to the comparative study of the methods for determining wave form, which in many practical cases departs so widely from the simplest type.

The determination of electrostatic capacity and the investigation of dielectric-hysteresis will also be given special attention, as will also the verification of standards of self and mutual inductance.

For the verification of alternating-current ammeters and wattmeters a set of Kelvin ampere balances, as well as considerable other apparatus, has been purchased, and a low-voltage storage battery of large capacity will be installed for supplying heavy currents. Facilities will be provided for the verification of alternating-current voltmeters from the lowest to the highest ranges. Instruments of various types have been ordered, and will be calibrated by the aid of a high-voltage test battery, 1,000 cells of which are to be immediately installed. One of the first problems will be to make a comparative study of various types of alternating-current instruments to determine the limits of error to which they are liable and the influence of the frequency and wave form on their indications. Provision will be made for the calibration of direct-reading wattmeters, as well as the commercial types of supply meters. Before this can be done for the public it will be necessary to make a careful study of several different types of alternating-

current meters. Only a limited range of work can, however, be attempted in the temporary laboratory, for lack of space and assistance.

Owing to the insufficiency of the force no work on photometric lines could be undertaken. Facilities will, however, be provided for the determination of the magnetic properties of materials, a knowledge of which is so important to manufacturers of electrical apparatus, and for the verification of magnetic balances and other apparatus for the determination of such properties.

Investigations as to the influence of treatment and chemical composition on the magnetic properties of iron and steel would undoubtedly be of great value to manufacturers, and will be taken up as soon as time permits.

The importance of accurate standards for photometric measurements is recognized by the bureau. It will, therefore, endeavor to place at the disposal of the lighting interests and the general public as soon as possible means for verifying such standards.

The Hefner amyl-acetate lamp, notwithstanding its numerous and evident defects, its reddish color, the influence of flame height, temperature, humidity, etc., upon its intensity, has been generally adopted as the primary standard. Only in the hands of a skilled observer are the results satisfactory, and the numerous corrections which must be applied render its use out of the question in industrial photometry. This has resulted in the adoption of properly treated incandescent lamps as secondary and as working standards, the luminous intensity depending only upon the voltage applied. Variations in the intensity with use are eliminated by using the secondary standards only for checking the working standards. The most urgent demand will therefore be met by providing facil-

ities for the verification of such lamps. One of the rooms in the temporary laboratory has already been fitted up as a photometric laboratory, with the latest type of comparing apparatus. Several Hefner lamps have been purchased, and orders have been placed for the necessary electrical apparatus, voltmeters, ammeters, wattmeters, resistance standards, and a precision photometer. A battery of sixty-six 200-ampere-hour cells has been installed for furnishing the necessary power, and regulating rheostats have been constructed.

One of the sources of error in photometric measurements is due to the difference between the color of the Hefner standard and that of the modern sources of artificial illumination with which it is compared, and an extended series of measurements by different observers skilled in photometry is to be arranged to study this source of error and to eliminate errors arising from the improper use of the Hefner standard.

While the most urgent demand is for properly verified standards of candle power, it is highly important that the bureau should make a comparative study of the different methods which have been proposed for the determination of the "mean spherical intensity," upon which the economic value of a lamp when used for general illumination depends.

The defects of the Hefner standard make it important to investigate further the different methods which have been proposed for the realization of a better primary photometric standard. Thus the "acetylene-in-oxygen" lamp and the Nernst glower should be investigated; but the most promising direction is that along which the Physikalisch-Technische Reichsanstalt has been working for a number of years; that is, in the study of the radiation from the inside of a hollow body, the walls of

which are maintained at a uniform temperature. The intensity of the radiation emanating from the interior depends only upon the temperature of the walls, and while the methods for the measurement of the high temperatures involved in photometric standards are not yet sufficiently precise, it is probable that the temperature can be defined in terms of the radiation emanating from a body at a lower and, therefore, more accurately measurable temperature.

During the fiscal year ended June 30, 1902, the following tests were completed by the bureau:

Nat. of test	For Gov'n't.		For Public.		Total.	
	No.	Value.	No.	Value.	No.	Value.
Length.....	35	\$79.15	123	\$155.30	158	\$234.45
Weight.....	109	102.50	99	53.00	208	155.50
Capacity.....	251	171.00	9	12.50	260	183.50
Temperature.	75	128.00	22	6.25	97	134.25
Electrical....	7	25.00	7	25.00
Sundry.....	273	583.70	52	325	583.70
Total	743	1,064.35	312	252.05	1,055	1,316.40

At the tidal power station of Ploumanach, on the northern coast of France, the difference of tide level is about twenty feet. The storage reservoir is a natural pond of four acres, having the form of a triangle with the base toward the shore, and in the embankment separating this from the sea are automatic gates which open when the level of the sea rises higher than the water in the pond, and are closed by the weight of the water in the pond when the tide recedes. The two water wheels of the station drive dynamos, which, aided by the storage batteries, are used for electric lighting. A prominent British engineer, James Swinburne, foresees the failure of this and all other plans for using the tides as a source of electric power on account of the great expense of working turbines on variable pressures or any kind of storage.—*Exchange.*

Lessons in Steam Engineering

FIRST PAPER

By CHARLES J. MASON

IN the mechanical literature of the day there is a scarcity of articles of an elementary nature, such as should be presented to a class of readers which appear to be almost forgotten—the young engineer. Of course, as we grow in years and continue in advancement we naturally look for something in keeping with our condition, and we are apt to look upon anything of an elementary nature as out of place and too simple to bestow any attention upon it whatever.

We should not forget, however, that the ranks are constantly being recruited by young men, to whom everything pertaining to the profession is entirely new, and the reading matter which just suits the full-fledged engineer is as Greek to the beginner. Now, it is a fact that a large percentage of the readers of mechanical papers are young men, eager for information and self-improvement along the lines which they have laid out for themselves, and it seems to me that it is only fair that the requirements of that class should be met and a few pages at least be devoted to their interests.

There is only one way to properly begin anything, and that is at the beginning. The tendency of most young men entering the engineering profession is to skip the elementary, commence at the middle, and rush through to the end; this because the importance of things elementary has never been forced upon them.

It does not occur to them that the durability of the entire structure depends upon the ground-work, the foundation. I refer particularly to that class of young men who have not had the advantages of a regular, systematic, technical education such as is given by so many institutions for the purpose throughout the land—the class that depends almost entirely upon its own efforts and the material that is placed before it to work upon.

It would, therefore, seem incumbent upon writers, editors, and publishers of engineering literature to place suitable subjects in a proper manner before the class of readers referred to, for, sooner or later, the more intelligent will see the wisdom of such a course. And then, on the other hand, perhaps the reviewing of a few simple facts, which may or may not have been learned in our youth, will be at once profitable and refreshing. Should, however, the older members of the craft see nothing of interest to them in this series of short and easy lessons in steam engineering, they will, I am sure, at least acquiesce in a few pages being devoted to their younger brothers.

The study of heat is the first to engage our attention; the nature of our knowledge concerning heat. When we place our hand upon a stove with a fire in it we experience a feeling of warmth, while if it be made to touch ice there is a sensation of cold. The impressions are sup-

posed to be caused in both cases by the same force or agent; in the first instance the impulse passing from the heated iron to the hand; in the second, from the hand to the ice. What the nature or essence of this thing is which produces such different feelings by moving in opposite directions, and which makes the difference between summer and winter, nobody has definitely discovered. It is named "heat." Some have thought it to be a kind of material fluid having no weight, existing diffused throughout all things, and capable of combining with all kinds of matter. This supposed fluid has received the name of "caloric." There are others who think heat is not a material thing, but merely motion. This latter idea is the more generally accepted theory of heat. Of the essential nature of heat we understand nothing, and are acquainted only with its effects.

If a given quantity of cold water be heated in a closed vessel till the water becomes hot, although the temperature of the water has changed, its weight remains the same. Should the heat be continued until all the water is converted into steam (assuming none of the steam is allowed to escape), the total weight of the steam is still exactly the same as the original weight of the water. The change produced by heat is not accompanied by a variation of weight, which, therefore, accounts for the theory that heat has no weight. It therefore cannot be a material substance.

Sir Humphrey Davy melted two blocks of ice by rubbing one upon the other, from which he concluded that the cause of heat is motion. Of course, things may be hot without being visibly in motion, but the motion exists in parts of the body too small to be seen.

All bodies are composed of small particles which are called molecules, held together by mutual attraction. These

molecules are in a state of continual agitation, and the hotter the body is the more rapid will the vibrations be. In solid bodies the vibrations are limited. If this limit is exceeded, owing to the addition of heat, cohesion is sufficiently overcome to enable the particles to move about freely, and now the solid has become a liquid. Should the heat still be continued, further separation of the molecules take place, cohesion is completely overcome, and the liquid is now a gas.

The pressure exerted by the gas on the interior surface of the vessel in which it is confined is due to the tendency of the molecules to fly apart from each other and strike upon the surface which confines them. The greater the heat applied the more violent the impact will be, and, consequently, the greater the pressure will be. The foregoing description of events is just what occurs within a steam boiler which contains water and to which heat is applied.

Now, if we had another vessel to which we could conduct the gas as it is formed, and this vessel contained a movable body, it is evident that, owing to the pressure exerted, this body would be pushed away by the incoming gas. In just such a manner is the piston within an engine cylinder alternately pushed backward and forward.

The object of the study of steam and its applications is to obtain from the steam engine the greatest possible amount of work for the least possible consumption of fuel, and this can only be successfully attained by a study of the underlying principles and elements. We see from what has just been stated that heat is a form of energy, and also that heat and mechanical work are mutually convertible—the one into the other. It will be shown that an exact and invariable relation exists between heat and work.

The intensity of heat in a body is called its temperature, and indicates how hot or how cold the body is. But the temperature of a body should be distinguished from the quantity of heat in the body. Temperature is measured by an instrument called a thermometer. The word thermometer is derived from thermo, heat, and metron, a measure, and it therefore signifies heat-measure. But what does it measure? That which is measured is usually named quantity. But we must not suppose that the thermometer indicates quantities of heat in any absolute sense. For example: If we dip a gill of water from a spring in one vessel and a gallon of water in another vessel, a thermometer will indicate exactly the same degree of heat in one as in the other; but we cannot infer that the absolute quantity of heat is as great in the gill of water as in the gallon. The thermometer simply shows the degree of intensity of the heat in its mercury, and, as this constantly tends to the same point as that of surrounding bodies, we take its degree to be their degree. If a thermometer suspended in a room stands at 70 degrees, we say the room is at 70 degrees because heat tends to equalization. If by opening a window of a room the thermometer falls to 60 degrees, we say the room has lost 10 degrees of heat, speaking of it as a measured quantity. In short, a thermometer indicates variable degrees of intensity, which are converted into expressions of quantity.

The ratio of the amount of heat required to raise the temperature of a substance 1 degree to the amount of heat required to raise an equal weight of water 1 degree is called the specific heat of the substance. The specific heat of bodies varies considerably. Water has the highest specific heat of any substance, except hydrogen, while the metals have the lowest. In other words, it takes

more heat to raise the temperature of a given weight of water 1 degree than to raise the same weight of any other substance 1 degree. The specific heat of water is 1. The specific heat of wrought iron is given as 0.113, or about one-ninth; that is to say, the quantity of heat which would raise one pound of wrought iron through 1 degree F. would only raise the temperature of one pound of water through about one-ninth degree F.

The zero of temperature on the thermometer scales has been chosen arbitrarily—on one the zero being the freezing point of water, and on the other a point 32 degrees F. below it. For scientific purposes it is necessary to have a uniform zero, and such a point, called the zero of absolute temperature, has been chosen, the position of which is 461 degrees F. below the zero on that scale, or 273 degrees Centigrade below the zero on that scale. Therefore, to express degrees Fahrenheit in degrees of absolute temperature, add 461. For example: the boiling point of water at atmospheric pressure is 212 degrees F., and 212 plus 461 equals 673 degrees absolute temperature.

I have referred to the relation which exists between heat and work, and we are now ready to deal with the subject.

Before quantities of heat can be measured we must have a unit of heat, just as we require a unit of length and a unit of weight. The unit of heat is the amount of heat necessary to raise the temperature of one pound of water 1 degree F. when the water is at its greatest density—39 to 40 degrees F.

The term work in mechanics is the overcoming of a resistance through space, and the amount of work done is measured by the resistance overcome, multiplied by the distance through which it is overcome. The resistance is meas-

ured in pounds and the distance in feet. For example: If a weight of 10 pounds be lifted through a height of one foot, then the resistance—namely, 10 pounds, multiplied by the distance through which it is overcome, namely, one foot—is equal to 10 multiplied by 1, equals 10 foot-pounds of work. Hence, work is measured by the product of pounds and feet, and the unit of work is the work done in raising one pound through a height of one foot, and it is called the foot-pound.

Because action and reaction are equal and opposite, the force which overcomes the resistance referred to can be considered instead. The work done by a force is measured by the intensity of the force, multiplied by the distance through which it acts, measured in the direction of the force. This is true for horizontal as well as for vertical directions, or for any direction between the two. Again, referring to the example, a force of 10 pounds overcame the resistance due to the weight, and acted through a space of one foot, doing thereby 10, multiplied by 1, equals 10 foot-pounds of work. There is no difference—as far as results are concerned—between 10 pounds lifted one foot and one pound lifted 10 feet; the product is exactly the same in both cases.

From the foregoing it will be seen that the unit of work is the product of two numbers, and can, therefore, be represented by an area. It is because of this fact that an indicator diagram obtained from an engine can be used to calculate the amount of work which the engine is doing.

It should be noticed that the unit of work has no reference to the time taken, for the same amount of work is done in lifting the weight, whether it be done in one second or one month. In short, work, as we are considering, is entirely independent of the time occupied.

But when we speak of power developed by an engine, or any kind of a machine, then time becomes an important factor in the calculation. The power of a machine is measured by the rate at which it can do work, and depends upon the amount of work done in the unit of time. The unit of power is the horse power, which is, in turn, the work done in raising 33,000 pounds one foot in one minute; or, in other words, 33,000 foot-pounds of work per minute. The phrase per minute is also important to be remembered.

So far, then, we have the unit of heat, the unit of work, the unit of power, and continuing:

$$\frac{\text{work done}}{\text{time in minutes}} = \text{units of work per minute}$$

and

$$\frac{\text{work done}}{33,000 \times \text{time in minutes}} = \text{horse-power exerted.}$$

When heat is applied to water it converts upon the steam made the power of doing work. This power of doing work is defined as energy. On the principle that matter can neither be created nor destroyed, so heat energy cannot be destroyed. It may assume different forms, but the sum total of energy remains the same. This principle is known as the principle of the conservation of energy.

The relation which exists between heat and work is expressed in the just law of thermo-dynamics, which reads thusly: "Heat and mechanical energy are mutually convertible, and heat requires for its production, or produces by its disappearance, mechanical energy in the proportion of 778 foot-pounds for each unit of heat. In the year 1843 Dr. Joule, a scientist, determined by an experiment that the temperature of a quantity of water was raised 1 degree through the action of 772 pounds falling one foot. Since then more accurate instruments and more carefully made tests have determined that 778 is more nearly exact, and it is the figure now used.

The Three-Phase Alternator

By FRANCIS H. DOANE

THE development of the design of alternating current machinery has led to the invention of many very ingenious devices and machines. Among these is the three-phase alternator, in which three distinct electro-motive forces are generated, and by means of a clever arrangement of armature coils and connections, makes use of only three line wires, to distribute the current to the load on the external circuit. It is our purpose in this article to investigate the general principles of this alternator. When a piece of wire is moved across the face of the pole piece of a magnet, so that it cuts across the magnetic lines, an E. M. F., or electro-motive force, is set up in the wire. This electro-motive force will force a flow of current through the wire, in case the wire forms part of a closed circuit. If the wire is moved down across the magnetic lines of force, an electro-motive force and current in one direction will be set up. If it is moved up across the lines, the electro-motive force and current set up will be in the opposite direction.

In an actual armature the wires, which serve as conductors, are mounted on, or near, the periphery of the armature. The steam engine turns the armature and thus forces the conductors to cut across the lines of force entering a south pole and then across the lines passing out of a north pole, or *vice versa*. The electro-motive force set up when cutting across

the lines entering the south pole, is opposite to that set up when cutting across the lines coming out of a north pole.

In Fig. 1 the three poles, N, S and N,

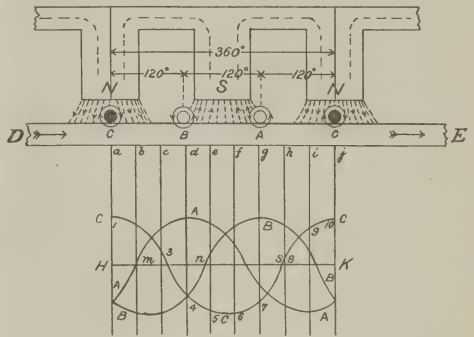

Fig. 1.

represent two north poles and one south pole, of the numerous poles on the field frame of an alternator. DE is a section of the armature core on which the conductors are mounted. For convenience the core, DE, and the pole pieces are represented as straight sections, whereas, in the actual alternator both would be curved. The motion of DE, imparted to it by the steam engine, is to the right, as indicated by the large arrows.

We will first consider the case of one conductor, C, moving across the pole faces. The direction of the lines of force from and to the pole pieces is represented by the arrow heads on the dotted lines. The end view of the conductors is shown. When current is flowing away from the observer, or we will say in a positive direction, the circle indicating

the conductor is black; when flowing toward the observer, or in a negative direction, the circle is clear. The arrow heads on the small circles surrounding the conductors represent the direction of the lines of force set up by the flow of current in the conductors. The connections of the conductors are not shown in this figure, in order to avoid a confusion of lines.

When a single electro-motive force is set up in a conductor, in a certain direction, the current flow will be in the same direction. In a two-pole machine, a conductor goes through one complete set of changes in electro-motive force values, or makes one cycle, in one revolution. Suppose it starts from the center of the N pole; it moves around to the center of the S pole, and then, continuing in the same direction, it comes back to the center of the N pole again.

In a multi-polar alternator a conductor goes through one complete cycle, in passing through a space equal to the distance from the center of one pole of a given polarity, to the center of the next pole of the same polarity. The space between the center of one N pole and the center of the next N pole is taken as 360 degrees, and is equivalent to one complete revolution of 360 degrees, in a two-pole machine.

Just below DE, Fig. 1, ten vertical lines are drawn between N and N. These lines cross a horizontal base line, HK. On the cross section paper thus formed, the various values of electro-motive forces may be laid out. Values above HK are positive; below, are negative. The electro-motive force set up in a conductor depends on the density of the lines and the speed of the conductor. The greater the number of lines cut per second the higher the electro-motive force. We will consider the speed constant. It takes conductor, C, equal

lengths of time to move the distance between any two of the vertical lines (see Fig. 1). The density of the lines varies. They are very dense under the center of the pole pieces, and less dense near the extreme edges. Between the pole pieces the conductor is moving parallel to the lines, and thus not cutting across them.

Start with C at position a. The conductor is moving in a dense magnetic field; it therefore has a high electro-motive force set up in it. We assume a value for the electro-motive force and plot it at point 1. At position b, C is still moving in a dense field, and the electro-motive force has fallen but little. Make a point, 2, on line b, slightly lower than point 1. At c, C is cutting across but few lines, so point 3 would have a low value. At d, C is entering the field of a south pole, and its electro-motive force is reversed.

When a conductor on a generator armature is forced past pole pieces, the electro-motive force set up in it is in such a direction that the current forced to flow sets up lines of force around the conductor, which are in such a direction that they agree in direction with the field lines of force in front of the conductor and are opposite in direction behind the conductor. This makes a denser magnetic field in front of the conductor than behind it. The steam engine performs work in driving this conductor against the dense field. Suppose we place several rubber bands between the thumb and forefinger, then try to move a pencil between the thumb and finger. It presses against the tightly stretched bands and we find it requires a considerable application of force to move the pencil. In somewhat the same way we may consider that the steam engine performs work in forcing the conductors against the interaction of the field lines and the conductor lines, which tends to force the con-

ductor in the opposite direction. If the conductor was free to move and had current flowing in it, so that there was a dense field on one side and a less dense field on the other, it would move away from the dense field and toward the less dense field. In much the same manner the pencil would be forced from between the thumb and finger by the pressure of the rubber bands, if we released our hold on it. The direction of the lines of force set up around a conductor by the current in it, is such that if we look along the conductor in the direction of current flow, the lines will be in a clockwise direction, or in the direction of the movement of the hands of a clock. If the current is flowing toward us as we look at the end of a conductor, the lines will be in a counter-clockwise direction. By observing the direction of motion of the conductor and the direction of the lines it is cutting, the direction of electro-motive force set up and the direction of current flow in the conductor may be determined. The denser field will be in front of the conductor. From the direction of the conductor lines of force we can determine the direction of current flow.

When C was at position a, the lines of force around it would be clockwise in direction, and current would be flowing away from the observer, stationed at the front of the armature. When C had moved to d, the lines would be counter clockwise, and current would be flowing toward the observer. The value of the electro-motive force at d would be indicated by negative point, 4. Positions e, f, g represent negative values, as shown by points 5, 6, 7. Between g and h the electro-motive force is reversed. Positions h and i give positive points, 8 and 9. Position j completes the cycle of changes and gives point 10, which is equivalent to point 1.

Suppose that a number of conductors which were 360 degrees apart was connected so that the electro-motive forces of all the conductors were in series and that the ends of the set of conductors were connected to two slip rings; we could obtain from the machine a single-phase alternating current.

At a point 120 degrees from conductor C, Fig. 1, place conductor B, and 120 degrees from B place conductor A. The shape of the electro-motive force curves will be the same for A and B as for C. The exact form of these curves depends on the style of winding, the shape of the pole piece and distribution of magnetic lines. The curve we have taken is slightly flat on top, as the field is fairly uniform under the pole pieces and varies rapidly in density near the edges of the poles. Some curves are flatter and other curves are nearly sine curves. In order to compare the electro-motive forces set up at any given instant in conductors A, B, C, plot on line a, the electro-motive force of C at position a, B at d, A at g. On line b plot the electro-motive force of C at position b, B at e, A at h, etc.

We can see that when C is at its positive maximum (P. M.), B and A are each at one-half their negative maximum (N. M.). When B is at its N. M., A and C are each at one-half P. M. When A is at its P. M., C and B are at one-half N. M. values. If a vertical line is drawn intersecting the three curves, the sum of the values of electro-motive forces indicated by the point where the line cuts the curves will be zero, or nearly so, taking into consideration the positive and negative values. In case the curves were exact and similar sine curves, it would be just zero.

It should be noted that the point m, where the electro-motive force curve of A started from zero, is 120 degrees from

n, where the curve of B is at zero, and that s, where the curve of C cuts the zero line, is 120 degrees from n. The electro-motive forces of the three conductors are 120 degrees out of phase with each other.

In considering Fig. 1 we have made use of single conductors only. On a regular armature coils of wire are used. The coils have each two sides active in cutting lines. The conductors making up the sides of the coil must be so placed that the electro-motive forces set up in them are in series, in order to obtain a high electro-motive force for each coil. There are several arrangements of coils possible on a three-phase armature. One style of winding is illustrated by Fig. 2. This has one-half a coil per pole

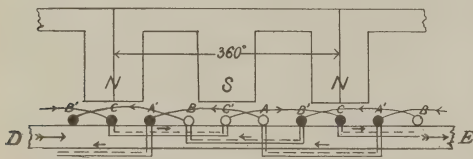

Fig. 2.

per phase. There are three sets of coils—AA', BB', CC'. In Fig. 2, A, B, C represent the conductors or group of conductors making up one side each of the three coils. These correspond to A, B, C, Fig. 1. The other side of the coils are A', B', C'. The end portions of the coils, which connect the active sides, are represented by the two parallel lines. The dotted lines are back-connecting portions of coils, the full lines front-connecting portions. The slightly curved lines show the manner in which coils in the same set of windings are connected together.

Consider coil CC' near the left-hand side of Fig. 2. The conductors at C are directly under the center of an N pole; the conductors at C' are under the center of an S pole. In C the current is flowing toward the back of the armature;

in C' the current is flowing from the back to the front. As the back of C is connected to the back of C', as shown by the dotted line, the current flows down C, across the back connection to C', up C', around the turns of wire of the coil, then across the connection to the C side of the next coil in the same set, down that, etc. The space between the sides of any coil is equal to the distance between the center of an N pole and the center of the adjacent S pole. When the conductors on one side of a coil are having electro-motive forces generated in them in a certain direction, caused by their passage across an N pole, the conductors on the other side of the coil are having opposite electro-motive forces generated in them by their passage across an S pole. The end portion of the coil so connects the active side conductors that the electro-motive forces are in series and are added together.

The coils in one set are connected together in series. This makes three sets, each consisting of several coils in series. There are several ways in which the sets of coils may be connected to the slip rings and external circuit. Let A, Fig. 3, represent one set of coils; B an

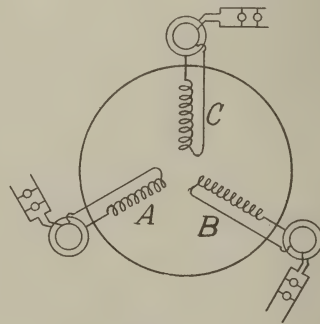

Fig. 3.

other, and C the third set. The ends of each set may be brought out to two slip rings and a separate circuit connected to each pair of rings. In this case there would be no connection between the

windings of the different sets; the machine would give out three separate single-phase currents. The currents in the circuits would differ 120 degrees in phase relation, as explained in connection with Fig. 1.

Let us now connect the c end of C to the b end of B and to the a end of A. (See Fig. 4.) The free ends are con-

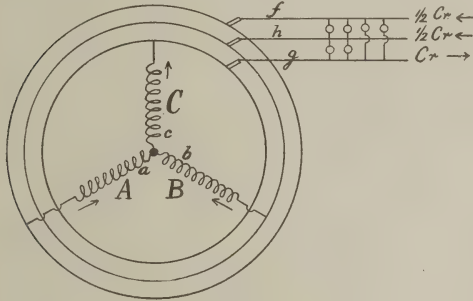

Fig. 4.

nected to three slip rings, as shown. Line wires f, h and g are connected by brushes to the slip rings. The load is connected between f and h, h and g, f and g. As shown in Fig. 1, the values of the currents tending to flow in a positive direction are equal to the values of the currents tending to flow in a negative direction. We will consider the positive direction as meaning away from the common junction of the sets of coils out to the line wires. The negative direction is the reverse of this. Suppose the C coils are at the P. M. positions. The P. M. current is flowing out from C to g, Fig. 4. At the same instant one-half N. M. currents are flowing in on f, A, and h, B, toward the common junction. There will be a P. M. current out on A and g, across the load to wires f, h, there dividing and flowing back on f, A, and h, B. All the current

that flows out on one or two of the three lines returns on the remaining wires or wire.

When B coils have an N. M. value of current an N. M. current will flow in on h and one-half P. M. is flowing out on A, f, and C, g. If the load is properly balanced only three line wires are necessary. Fig. 4 illustrates the Y or star method of connections.

The Δ (delta) method is shown in Fig. 5. Consider the currents in the

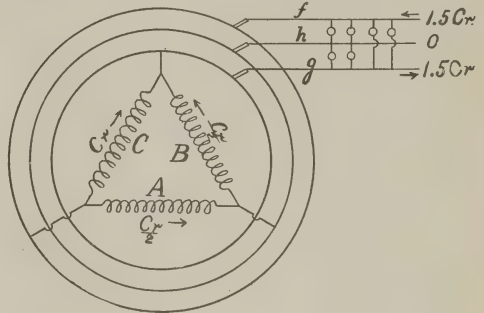

Fig. 5.

coils. The positive direction of current may be taken as a clockwise direction of flow of current around the closed circuit winding. Suppose the current in C is at its P. M. value, the currents in A and B are one-half N. M. value, and in such a direction that the sum of the currents, taking into consideration their positive and negative values, is zero. There would be 1.5 cr., if cr. is the maximum current in one set of windings, flowing out on g and 1.5 cr. flowing in on f. At this instant there is no current in line wire h. Other points on the curves may be taken and the current traced. Only three line wires are necessary for this style of winding and connections.

Steam Turbines to Date^{*}

By R. H. THURSTON, LL.D., Dr. Eng.

Director of Sibley College, Cornell University

THE beginnings of the steam turbine are found in the earliest historic times and in the earliest technical literature. Its progress is shown to be wholly modern and mainly recent. Only after the evolution of the modern physical and mathematical sciences could its action be understood and the machine be properly designed; only after modern tools and methods of mechanical construction had become refined could it be built in safe and economical forms. The influence of the Alexandrian school upon modern engineering is shown to have been mainly through the philosophers who sowed the seeds of which we now see the germination and the fruit. They were necessarily dormant during the nearly 2,000 years which elapsed between the days of Greek philosophy and modern practically applied science.

The fundamental ideas of the theory of the steam turbine are exhibited as embodied in the modern steam turbine. The transformation of energy from its thermal into its dynamic form is traced, and the principles controlling the thermo-dynamic change and the limitation of wastes are exhibited as exemplified, both for the ideal case of the perfect machine and for the practical construction of the day. The method of development of

thermal energy is exhibited, and the mechanism of the process of change into dynamic form is shown.

The turbine is discovered not to be a thermo-dynamic machine, but to belong to the same class with the hydraulic turbine and its design, construction and operation to be controlled by the same ultimate principles. The radical distinction between the types of the ancient Greek and of the engineer of the seventeenth century is pointed out, and the influence of this difference in type upon the practical value of the invention is brought out. The limitations controlling the engineer in his design and construction due to this difference in type are exhibited, and their effect upon the economic value of the turbine is shown. Notwithstanding these limitations, it is found that the turbine is more nearly a "perfect steam engine" than any other known type, so far as its design and construction are concerned. It remains to be seen what the practical outcome is to be.

The economies and the wastes of the steam turbine are discussed, and it is found that the machine, if its construction can be made perfect, will operate precisely as would its purely ideal representative. Its preliminary thermo-dynamic conversion of energy in the formation of its jet within the nozzle is exactly conformatory to the scientific

^{*} Abstract of lecture given before the New York Electrical Society, March 18, 1903.

theory of the case and the action of the turbine itself, receiving the jet, is that which a scientific and perfect construction would illustrate, in so far as energy conversion is concerned, if the apparatus be correctly proportioned and constructed.

It is discovered, on investigation, that the wastes of the turbine, as now illustrating the best work of the time, are apparently not far different in amount from those of the best work on the older type of steam engine, the piston engine, but that these wastes are of a different sort and peculiarly distributed. The problem of their reduction is a radically different one from that of the older engine.

The present status of the turbine as respects design is shown, and its relation to the ideal standard of the engineer is examined into. The Hero turbine as used in "centrifugals," the Branca type as employed in the same class of machines, the old Avery and Atwater types, and the recent forms of DeLaval and Curtis, Parsons and Rateau, are shown to approach the theoretical ideal more completely than ever has, or probably ever can, any reciprocating engine. It does not necessarily follow that they will ultimately excel the common type of steam engine in every-day practice; it simply means that to this extent they possess certain fundamental advantages. The fundamental principles of the steam turbine being now entirely familiar to the engineer, its design has become one of the simple problems of construction, and may be carried out with perfect comprehension of the requirements of the case, as well as of the methods of successfully meeting those demands.

The now familiar types of simple and of compound turbine illustrate the familiarity of the engineer of to-day with this task. He recognizes his limitations,

as set by the weakness of his materials of construction and by the essential requirements for maximum thermal and mechanical efficiency which make demands upon him which are in precise opposition. He effects the best compromise possible in the one case and endeavors by a modified design to evade those limitations in the other case. Various expedients and various special devices, some of them amounting to real inventions, are found to be more or less successful in effecting this improvement and the differences among the steam turbines of the day are largely of this sort.

The fundamental principles of the compound turbine are simple, and all forms of such machines are fundamentally the same in principle.

The performance of the steam turbine of the day, as observed by the lecturer and as shown by the work of many other investigators, is found to be excellent beyond the anticipations of the most sanguine among older practitioners. Figures presented show that the machine is about as economical as other engines of the same power, that its regulation may be made satisfactory and its adaptation of special purposes is remarkably perfect. It is found that, while experience is not by any means as complete, and judgment, therefore, not so well based as with the more familiar types of engine, the conclusion is probably well justified that this form of steam engine has come to stay, and that it will find its field, and a broad one, in the engineering of the future.

Opportunities for improvement are found, on investigation of the theory and of the performance of the machine, comparing the predictions of a pure theory with the results obtained in a refined practice, to be very large. The direction which these improvements must take is shown clearly by experimental research,

and the way is clearly visible to all scientific designers and inventors. It is easily shown that there are two, and practically only two, ways of securing further gain in the efficiency of the turbine, the one involving the refinement of the construction of the machine, the other relating to the treatment of the working fluid. The method is simple in its requirements, but the practical meeting of these requirements may involve some difficulties. However that may be, the designers of to-day are competent, well informed, and have the scientific training needed. They may be expected in due time to attain a high degree of success.

The characteristic advantages of the steam turbine in its now standard forms are, for certain purposes, peculiar and very important. The adaptation of the machine to driving high-speed machinery, to the turning of the armature or the field of the dynamo, to the purposes of the marine engineer, present promising problems. Their solution is already well advanced, in most cases, and we already know what the turbine may be made use of in the operation of machinery, as of alternating-current generators in multiple, where the difficulties with other motors are found to be singular and serious. These advantages are illustrated by the details of the engine trials and of scientifically conducted investigations lately effected.

The trend of progress and the promise for the immediate future is in the direction of further gain in economy of the machine by suppression of leakage and of friction of fluid within its casing by improved workmanship and by securing a better working substance by freeing it from water, and also by utilizing the process of superheating to increase the thermo-dynamic range. This means, however, improvement at the boiler rather than at the engine, which latter is

fitted in all its forms to employ superheated steam of any temperature that can be practically furnished from the steam generator.

The trend of progress at the moment is also toward the application of specially designed and constructed turbines to special uses. It is probable that, gradually, forms will be adapted particularly to use in electric light and power "plants"; others will find employment as marine engines, and still others to other varieties of work. The regulation and the adjustment of speeds constitutes a problem, already satisfactorily solved in some cases, but which requires some further consideration in adaptation of satisfactory regulating mechanism to some special forms of turbine and to some special uses.

The promises would seem, at the moment, to be the introduction very widely of a new type of prime mover which adapts itself in a peculiarly happy manner to purposes to which the common forms of steam engine are not likely to prove perfectly satisfactory. The indications are that the supply of power by means of this motor will be made as low as with the best types of reciprocating engine, and possibly lower, while its simplicity of plan and ease of construction would seem to insure freedom from liability to either accident or depreciation of value to any important extent for long periods of time. The construction and use of the machine are so well understood, and the real so closely approaches the ideal, that the engineer may readily see his way toward the solution of any practical problem of design that may be presented, while he also may as readily see a remedy for any observed defect of efficiency or of mechanical action. It should, therefore, be expected that such approximation to the ideally perfect machine as is possible will soon be attained;

particularly as already the study of the theory and the observation of the practice of the time with this machine is now being made the task of an immense number of learned men of science, of able practitioners, and of skillful constructors. Probably never in the history of engineering was so simple a machine made the object of investigation of so large a number of

able men, investors, constructors, engineers, and men of science, and the subject of such extensive experimental research.

It is very possible that, through the development of this ancient device, we may yet see the nearest approximation to ideal thermo-dynamic and mechanical efficiency in the group of heat motors that man can attain.

New Publications

Conductors for Electrical Distribution.

By **FREDERIC A. C. PERRINE**, A. M., D. Sc. D. Van Nostrand Company, New York. Pp. $6\frac{1}{2} \times 9\frac{1}{2}$ in., 287; illustrated; cloth, \$3.50.

IN the preface of this work the author states that it represents the results of over ten years of work as a manufacturer of insulated wires and cables, as an engineer advising concerning their installation, and finally as a teacher of electrical engineering. After a perusal of its contents, and taking into consideration the author's wide experience in the field of electrical conductors, we feel no hesitancy in stating that his work will rank as an authority in this particular branch of electrical engineering.

The work is divided into fifteen chapters, as follows: Conductor Materials, Alloyed Conductors, The Manufacture of Wire, Wire Finishing, Wire Insulation, Cables, Calculation of Circuits, Kelvin's Law of Economy in Conductors, Multiple Arc Distribution, Alternating Current Calculation, Overhead Lines, The Pole Line, Line Insulators, Underground Conductors.

In the chapters relating to the manufacture of wire the processes are given

in a more complete manner than ever before presented, while the chapter on Kelvin's Law of Economy contains a large amount of original matter, which is treated in a comprehensive and practical manner. In the chapter on Pole Line will be found a simple method of working out the strains in suspended wires, used by the author and Mr. Babcock in calculating the successful aluminum line that was run from the Standard Electric Company's plant to Stockton, California. The chapter on Alternating Current Line Calculation is a résumé of a paper read by Mr. Baum—a former pupil of Dr. Perrine at Stanford University and now a professor at that institution—and the author before the American Institute of Electrical Engineers, and contains, we believe, the first complete method of calculation that has been published in this country. The presentation of the difficult and hitherto untreated subject of wire manufacture has been skillfully handled, and gives a very complete exposition of the different stages in the process, as well as the development of the industry. The book is illustrated

with half-tones and line drawings, as well as five folding plates for use in line calculation.

The Official Handbook of the International Brotherhood of Electrical Workers contains the complete directory of the local unions, list of officers, extracts from the constitution, and other matter of general interest to members of the above organization. An article on "The Operation of Electric Generators in Multiple," by C. C. Custer, illustrated by a number of line drawings, should prove of interest, as it explains in detail the manner in which the above is brought about.

The February number of the "Transactions of the American Institute of Electrical Engineers" contains the addresses of President Scott and Messrs. Lockwood and Hammer, on "The Telephone Switchboard," "The Evolution of the Telephone Switchboard," and "An Automatic Telephone Operator," recently delivered before the Institute. In connection with the same the discussions following the above addresses are also presented. Some other papers which were recently read, as well as a list of the books and pamphlets presented to the institute library by Dr. S. S. Wheeler, are also presented.

The April number of the "Journal of the Franklin Institute" contains a number of interesting articles, one of the most important being one by Prof. W. M. Stine, on "The Contributions of H. F. E. Lenz to the Science of Electro-Magnetism." Other interesting papers on civil and mining engineering, metallurgy, photography and microscopy, physics and water supply are presented, as well as a number of valuable notes and comments on various engineering topics.

The April number of the "Yale Scientific Monthly," published monthly by the students of the senior class of the Sheffield Scientific School of Yale University, contains, among others, an article on the life and works of James Smithson, the founder of the Smithsonian Institute, at Washington, D. C., by Almer Mayo Newhall. Leigh Page, in "The Habitability of Mars," gives forth in an interesting manner the pros and cons of this question. He concludes by saying: "Even if Mars be dead, what reason is there for believing that none of the countless millions of suns, spread out in all directions in infinite space and showing all stages of development, have planetary systems at least one of whose members has reached a suitable condition and developed life, possibly of a far higher order than any known on earth? Such speculation, however, must be left for the minds of poets; where there are no means of obtaining data, here scientific investigation cannot proceed." In his "Life of Galileo," Douglas R. Harts-horne gives a brief sketch of that famous astronomer's career.

The March number of the little monthly issued by the Edison Electric Illuminating Company of Brooklyn, is devoted to the electric lighting of Brooklyn's theaters. "The Brooklyn Edison" states that every theater in the borough is supplied with current by the Edison company. Mention is also made of the revised schedule of prices and discounts for electric power service, which became operative on April 1st. An interesting feature of the new schedule is the large reduction it effects in the rate to small consumers—concerns operating with motors of five horse power or less. In the case of those whose bills will average between 100 and 250 horse-power hours per month this amounts to as much as

16 per cent. The gross rate per horse-power hour is reduced from 12 cents to 10 cents.

The new schedule will embrace all customers, old and new alike, and is as follows: Rate per horse-power hour (746 watts) by meter measurement, 10 cents, less a cash discount from monthly bills as per following table:

A discount of	20%	on	100-250 h.p. hours
" " "	30%	"	250-500 " "
" " "	40%	"	500-750 " "
" " "	50%	"	750-1000 " "
" " "	55%	"	1000-2500 " "
" " "	57½%	"	2500-5000 " "
" " "	60%	"	over 5000 " "

Illustrations are shown of the principal playhouses of Brooklyn, one of them being reproduced in tint. The last page contains a directory of manufacturers and wiring contractors, as well as a schedule of motor prices. The letterpress, etc., of our little contemporary are beyond reproach, and are only equaled in excellence by its contents. We believe that copies will be furnished on request.

In a booklet recently issued by the Fort Wayne Electric Works is described "Perfection in Transformer Insulation: How It Is Attained." The vital importance of insulation, the dangers which the lack of it entails, and the various methods employed to produce a perfect insulation in transformers, as practised by the above company, are well set forth. The value of the booklet is enhanced by a number of well-chosen illustrations, showing the interior construction of transformers, etc.

Two little booklets, entitled respectively "The Law of Trademarks of the United States and the Principal Foreign Countries" and "Trademarks: A Book for Advertisers," have been published by Mr. Luther L. Miller, 1237-8 Monadnock Block, Chicago, Ill., and we believe

them to be of considerable importance to manufacturers and advertisers. The first-named booklet contains a summary of the trademark laws of the United States and the principal foreign countries, while the latter is a dissertation on the offices and advantages of the trademark. While the above were not intended for general distribution, copies will be sent to readers of "The Electrical Age" on request.

The Publication Bureau of the General Electric Company has just issued a pretentious booklet on fan motors. In a brief sketch is described the evolution of the fan, ending with the statement that the link which binds the fan motor to the object that has served for pomp, frivolity and beauty is doubtless described by a traveler in Italy of the sixteenth century, who writes of swinging screens suspended from the ceiling and operated with cords by six servants, producing "wind enough in my room to wreck a vessel." In the pages following are described in detail alternating and direct-current fan motors and blowers. All the various types are aptly illustrated, besides which some of the more ancient types of breeze creators used by our forbears are shown, beautifully depicted in tint. The booklet is exquisitely gotten up, and a worthy example of the art preservative in its highest state.

Bulletin 32 of the Swett & Lewis Company, 18 Boylston street, Boston, has just been issued, and treats of electrical novelties manufactured by this concern. Illustrations, descriptions and prices of "Ultra" vacuum electrodes, X-ray tubes and stands, multiple spark interrupters, spark lamps for producing violet rays, spark regulators for coils, electric heaters, X-ray plates, etc., are

given. The catalogue will interest all who are interested in electro-therapeutic work, and will be sent free on application.

The Garvin Machine Company, Spring and Varick streets, New York City, have just issued Catalogues No. 9, No. 2, No. 1 and "A Modern Machine Shop Outfit." No. 9 is devoted to milling, screw, tapping, and other machines and their attachments; No. 2 to plain milling machines; No. 1 to universal milling machines, while in the "Modern Machine Shop Outfit" illustrations of various machines used in machine shops are shown. With the exception of the last named, the catalogues give extended descriptions of the machines shown. They reflect much credit upon the compiler, and will be sent free on request.

"Westinghouse Fan Motors" is the title of a new booklet issued by the Westinghouse Companies' Publishing Department. It describes in detail the Westinghouse fan motor for direct and alternating circuits. Illustrations showing details of construction, and also various applications, embellish the pages of this pamphlet. Copies will be mailed on application.

The Bullock Electric Manufacturing Company, of Cincinnati, have issued for distribution "The Electrical Operation of Modern Machine Tools and Machinery," a paper read before the New York Electrical Society November 26, 1901, by Robert Lozier; also "The Electrical Equipment of a Modern Shipyard," be-

ing a reprint of that article in the "Electrical Review." Both of the above are devoted to the benefits of motor-driven machinery, and give facts and figures in substantiation thereof. To the manufacturer who has not yet discarded the older methods of driving, the above pamphlets ought to be of much value and interest.

An Electrical Town.

Davos, the famous European health resort, will soon become noted for being a town making use of electricity not only for lighting, but also for heating, and, indeed, for all purposes, industrial as well as domestic. Two large waterfalls in the immediate vicinity will furnish power for driving a series of generators of from 5,000 to 6,000 horse power. Already a number of the principal hotels have adopted electricity for heating, and in many of the kitchens electric cooking stoves are used exclusively. The principal baker of the place bakes in an electric oven, while the laundresses use flatirons heated by electricity.—*Exchange.*

An absolute vacuum may always remain unknown, but a close approach to it has been reached by Professor James Dewar in his determined search for the absolute zero of temperature. He uses no air pump. A glass receiver with a small receptacle at the bottom is filled with air, which is then frozen and falls into the lower tube. The neck of the latter is then sealed in the blow-pipe flame, when the portion containing the air is broken off.—*Exchange.*



Current Engineering and Scientific Notes

Abstracts from the Foreign Papers



Oil Fuel For Steamers.

(*Petroleum, London.*)

SOME data are given, showing the oil consumption of the steamer Breakwater, during her various trips after she was equipped with oil burning apparatus. The particulars are as follows:

Voyage No. 16 (No. 1 with oil)	..	1,040	barrels oil used
" 17 (No. 2 ")	..	1,036	" "
" 18 (No. 3 ")	..	not rated.	" "
" 19 (No. 4 ")	..	917	barrels "
" 20 (No. 5 ")	..	1,007	" "
" 21 (No. 6 ")	..	977	" "
" 22 (No. 7 ")	..	959	" "
" 23 (No. 8 ")	..	869	" "
" 24 (No. 9 ")	..	887	" "
" 25 (No. 10 ")	..	857	" "
" 26 (No. 11 ")	..	827	" "
" 27 (No. 12 ")	..	817	" "

Usual consumption of coal on previous voyages..225 tons
Ratio of oil to coal, voyage No. 27 .. 3½ barrels = ton

Pneumatic Tires for Motor Cars.

(*The India Rubber Journal.*)

The writer, after giving a brief review of the rubber tire, from the cushion to the pneumatic tire, states that just as the latter type was attaining what may be called perfection there began the development of an industry which has since increased by leaps and bounds—namely, the motor car trade.

This opened up a new field for tires, and with it came new problems. As with the bicycle pneumatic tire, so have the patents for motor car pneumatic tires followed thick and fast upon the progress of the trade. One of the favorite phases of motor car tire patentees runs something like this: "Hitherto pneumatic tires for motor cars have simply followed the principle of pneumatic tires for bicycles." Then follows the argu-

ment against this idea, and an account of how the patentee's tire breaks away from this accepted rule. A long course of reading of motor car pneumatic tire patents, however, shows that the more the patent departs from the principle of bicycle pneumatic tires the less has been its success, and, despite all arguments to the contrary, the motor car tires which are at present the most successful are precisely those tires which are developed on the principles governing the bicycle pneumatic tire.

The expense of tires being considerable, a tire which is cheap at first, but which experiences a greater wastage, will not have that success which sometimes attends cheaper articles in other lines, for the automobilist, facing the necessary expense in tires, will take into account this wastage, and thus will naturally rather pay more for the better article than for that which will require renewing and consequent trouble at an earlier period. Then, again, the whole luxury and pleasure of a motor car is in a great measure dependent upon the tires, and an anticipated pleasure spoilt in the first hour by a breakdown of a tire soon makes car owners careful as regards their choice.

At the present moment the competition in pneumatic tires for motor cars is that of reliability versus resiliency. Starting with two tires of the best possible manufacture, the tire which has the thicker thread will be less resilient, but will be less liable to punctures. The tire

with the thinner thread will be the more resilient and more liable to punctures. The thicker the thread the more closely do you approach the solid rubber tire as regards resiliency; indeed, we imagine that the thickness of thread required to give results only equal to the solid tire is not so great as many manufacturers imagine. He states that the question which has now been lifted into so great a prominence as to dominate many other issues is the problem of a non-skidding tire. This is one of the most curious questions which has yet cropped up in the manufacture. The methods adopted to prevent skidding are many, but only four have come into general use. One of these is the interlacing of a chain around the outside of the tire, and unquestionably this diminishes the skidding evil, and, it is said, results in no harm to the tire. Another method is the making of an outer cover having heavy rubber corrugations across the face of it. Another cover has been tried made with very deep indentations running round the face of the tire. Still another method, and this the last, was shown for the first time at the Crystal Palace, Sydenham, England. In the center of the tire (which has a flat face) are screwed a number of metal discs, with the face cut in facets. The fear that the introduction of these metal discs into the tire would soon destroy the latter is said to have no foundation in fact, as a tire constructed in this method has run some thousands of miles.

Concluding, the writer states that he is inclined to believe that the non-skidding method which will be ultimately adopted has still to be discovered.

Electrical Ore Finding.

(The Electrical Review.)

The following is a brief description of the apparatus employed by Messrs. Daft

and Williams in their electrical ore prospecting method, which they are the inventors of.

A primary source of electrical energy is provided, a lithanode battery being preferred by the inventors of the system. Energy supplied at a comparatively low voltage is transformed to a high voltage, ranging from about 30,000 to 150,000 volts, and by the use of a specially constructed spirit break and a spark-gap, waves of any desired frequency can be obtained from the secondary. The current impulses at high voltage are conducted by surface wires to the desired spot. The wire is connected with a short rod, the point of which is thrust into the surface of the earth, and serves as one pole. A similar rod, forming the second pole, is fixed at a chosen spot either underground, in a mine tunnel, or on the surface. The positions of these rods would be determined by such data of the geological formation of the strata in the vicinity as were available to the explorers.

To determine the locality of minerals a separate piece of apparatus is employed. The essential member of this is a delicately constructed "resonator," which is enclosed in a small case fixed on a light tripod. The resonator is said to be tuned to receive from the earth the electrical oscillations produced by the inductor and impressed on the earth.

The resonator is provided with two receivers, which enable the oscillations to be made audible to an explorer. The resonator is connected with earth by means of two wires, each of which is provided with a short earthing rod or electrode, the point of which is thrust into the earth during an observation. The wires are otherwise insulated.

In making an investigation, the explorer would place the resonator in the

position which, in his judgment, was most likely to lead him to discover any vein or pocket of ore which might be in the vicinity. The normal sound would be noted. The resonator line would then be moved gradually round at a distance of forty or fifty feet, and the character of the sound would be observed. If no other sound than the clear note were perceptible within the radius, the instrument would be moved to a fresh area, and this would be similarly explored. In the event of any clear variation from the normal, the fresh sound would be studied as closely and accurately as might be, and a conclusion arrived at from the results. If it were thought advisable, a duplicate system of working would be adopted; two "fields of force" would be focussed so that their waves coincided at an angle determined upon, and would be employed on the area to be investigated.

Demonstrations of the method were recently made by Mr. Williams in the presence of a number of electrical and mining experts and others interested in the working of minerals. The tests were made on land adjacent to the Talacre Mine, Prestatyn, North Wales. About \$180,000 have been spent in working the mine, but so far without remunerative ore having been reached. On the request of the directors, Mr. Williams conducted a series of investigations by means of his electrical system. The conclusions arrived at as a result are that there is lead in the area to the west southwest line of the old adit, and also below a certain point in the old adit about half-way between the mouth of the adit and the forebreast. The results were checked by investigations from different base lines, and in each case similar indications were obtained. As a result of the investigations the directors have decided to raise \$100,000 to de-

velop the mine on the lines suggested by Mr. Williams. Our contemporary is inclined to look upon the Daft-Williams system with a little scepticism. Were the earth's crust homogeneous, and were the lodes of ore widely separated from one another, the matter would be greatly simplified; but, under actual conditions, there is no end to the combinations and interferences that must be analyzed and interpreted. For example, assuming that the presence of ore could be detected as claimed, two or more existing lodes might produce a resultant effect equivalent to that of an imaginary one near neither of the real ones, and the sinking of a shaft would result in a dead loss.

Monorail Railways for British Columbia.

(The Railway and Shipping World, Toronto.)

Some interesting facts regarding monorail railways are given apropos of the application to the legislature of British Columbia to construct railways of the above type in that province.

The monorail system was first patented in 1821; in 1825 a short piece of line was constructed and operated successfully on the London, Eng., docks, and in 1864 the system was adopted to some extent in the Philadelphia coal regions. These lines were more or less experimental in their character, and used only for freight, and no attempt was made to bring it into use as a passenger line until after the improvements made by Latrique had been effected. As the north of Ireland was the pioneer in Great Britain in the adoption of electricity as a motive power for railways, on the line from Portrush to the Giant's Causeway, the south of Ireland took up the monorail, and in 1887-88 the first railway on that system was constructed from Listol to Ballybunion, County Kerry, un-

der the direction of F. B. Behr, who has been retained as consulting engineer by the promoters of the British Columbia company. The Irish line, constructed after experiments in London, in 1886, had proved the value of the Behr improvements, and in 1897, after further experiments had been made, a high speed line was constructed at Brussels, Belgium. The Irish line has proved to be a safe and speedy means of conveyance in a rugged and sparsely populated district, and on the Belgian line with a carriage weighing about 70 tons, which was much in excess of the intention and estimate, a speed on curves of over 25 chains radius of 83 miles an hour, and a speed of 70 miles an hour on an ascent of 1 in 90, were attained.

~

The Grounding of Dynamo Electric Machinery.

(The Electrical Review.)

Arthur Bloemendal, of Vienna, in some notes on the above subject, states that, according to all past experience, it is more or less dangerous for the human body to come in contact with 300 volts, depending on the circumstances under which the contact occurs, and also on the constitution of the individual concerned. In order to prevent any fatal interference with high-pressure machinery and apparatus, he recommends two methods—either the complete insulation from earth or grounding the parts which do not carry current. He prefers the latter method—which he has adopted with the Vereinigte Electricitaets Aktiengesellschaft, of Vienna—as, by a conscientious and practical application, it insures absolute safety and excludes any danger from handling the apparatus.

The high-pressure machines are surrounded with sheet-metal flooring, which again is connected with earth. The grounding cable is carried round the sheeting one or two inches from the outer edge, thus forming a complete framework for the machine; only then is the grounding cable connected with the earth plate.

When working with or near the machine under pressure the workman treads on the metal flooring, which must have the same potential as the skeleton of the machine itself. Naturally, the metal flooring must be so large that a contact with the machine is only possible while standing on the metal. This is important, as there may be a potential difference between the flooring of the machine shop and the metal sheeting, a fact which the author has proved by actual tests. This should also be considered when making switchboards for high-tension installations. The Vereinigte Electricitaets Aktiengesellschaft make their high-pressure switchboards so that only low pressures are present on the front of the marble, and the whole of the instruments, such as ampere, volt and wattmeters, are provided with reduction transformers, which are arranged in an iron frame at least 1.5 m. to the back of the marble partition. On this iron frame are also arranged the switches and safety accessories, and the switches are operated through levers. The handles of the high-pressure switches are grounded, while the switchboard itself is usually placed on an iron platform, also connected with the earth. It is thus out of the question that the switchboard attendant can ever receive a fatal shock through contact with the high-pressure switches.



Power House at Morbegno, Italy, of the Valtellina Railway.

The Valtellina 20,000-Volt Three-Phase Railway in Italy*

By W. M. J. HAMMER

ABOUT two years ago I had the pleasure of visiting the works of Messrs. Ganz & Co., in Budapest, Hungary, and, through the courtesy of Director Otto F. Blathy, I was given facilities to study the company's 20,000-volt three-phase system for operating electric railroads.

I shall have the pleasure of presenting some details of the generating plant and railroad equipment in Northern Italy, which I had the pleasure of visiting last September.

For nearly two years Messrs. Ganz & Co. have been installing this plant,

* From a paper read before the Franklin Institute on February 12, 1903.

and it was officially started up September 4, 1902, and this firm and the Società della Rele Adriatica, for whom the work was carried out, are to be congratulated upon the pluck and perseverance they have shown in grappling with the well-nigh insuperable difficulties they have had to contend with, and the very able manner in which they have carried out this stupendous undertaking, which represents the most important and interesting electric railway installation in the world; and it is indeed remarkable that so little attention has been given by engineers, especially in this country, to this important and successful effort to

establish long-distance electric railroad-ing under steam railroad conditions.

I arrived on the ground early in September, 1902, almost simultaneously with the starting up of the road, and spent some days traveling over the entire line, and although the Lecco Colico section was not being electrically operated at the time of my visit, all the rest of the road was, and I can bear testimony to the remarkable success of the operation of the road, which compared very favorably in smoothness and reliability of running, in starting and stopping, etc., with any road I am familiar with, either here or abroad, and I am informed that the company already has under contemplation the equipment of the road from Lecco to Milan, in addition to the 72 miles already in operation.

This railway system has until recently been operated by steam, and is known as the Lecco-Sondrio & Chiavanna Line. Enormous difficulties have been met with in the installation of this plant, not so much in the employment of the initial voltage of 20,000 volts, but in dealing with the difficulties of the road-bed, which, as in all Italian roads, is execrable; also by reason of the length of the line, the problems in freight and passenger haulage, the very large number of tunnels the road had to pass through, the high winds and freshets in the mountain streams, and the difficulties in electrically equipping a standard gauge road of 72 miles in length during the time that it was being constantly operated as a steam road.

The power house represents about 7,400 horse power, with facilities for increasing this when necessary.

The plant itself consists of three 2,000-horse-power Shuckert three-phase alternators of the revolving field type, supplying 20,000 volts at fifteen cycles; these are direct connected to three tur-

bines supplied from a raceway between two and three miles in length, sections of which are open cuts through the rock, and other sections being through tunnels. The water is carried to the head stock 90 feet above the station, and delivered at the rate of 35 cubic meters per second.

At the time of my visit but one alternator was being used, and it was claimed that this could be made sufficient to operate the entire road; and the engineers have been surprised to find they would have such a very large reserve of power above all present requirements.

The power plant is placed at Morbegno, $9\frac{1}{2}$ miles from Colico, or $15\frac{1}{2}$ miles from Sondrio.

The three-phase current of 20,000 volts is connected directly to the primary line, which supplies nine sub-stations equipped with ten 300-kilowatt Ganz transformers, and the necessary switches, arresters, and motor-driven ventilating devices for the transformers. At these sub-stations the current is stepped down to 3,000 volts, these stations furnishing current to the 11 independent sections of the overhead trolley line, each about six miles in length. Each of these circuits is equipped with fuses. The two overhead trolley wires, each eight millimeters in diameter, represent two of the phases and the track the third. The line insulators have five petticoats, decreasing in size from top to bottom, and are made of porcelain. The poles are of wood, but eventually will be replaced by steel poles. The line wire, which is of copper, is seven millimeters in diameter, and was doubly insulated and flexibly suspended.

The high-tension 20,000-volt feeders were carried over or around all tunnels, some 32 in number; but the 3,000-volt trolley wire passed through all tunnels, being supported from the roof at a height

of four meters 80 centimeters. Especial privileges were accorded by the Government for placing these circuits below the regulation height of six meters, where they passed through the tunnels, and it was found necessary to replace the lateral suspension by a longitudinal suspension, owing to strains originally breaking the supporting devices. The increase of speed over that employed in operating the road by steam necessitated the changing of the pitch of the road, and also necessitated altering the trolley circuit to prevent the trolleys striking the tunnel sides. There are 17 regular stations and eight extra stopping places. The stations are supplied with incandescent lighting from the railroad power plant at Morbegno through suitable transformers.

Passenger and freight traffic is operated independently. At the time of my inspection they had 10 passenger trains and two freight, and were expecting, in addition, three more passenger and two more freight trains.

The freight locomotives are approximately 700 horse power, employing four motors, and are capable of hauling 250 tons up a 10 per cent. grade at a speed of 19 miles per hour, and will haul 500 tons on the level.

The passenger locomotives are also equipped with four primary motors, operated in parallel, each weighing about $3\frac{1}{2}$ tons, and representing 300 horse power. The schedule speed is about $37\frac{1}{2}$ miles per hour on the level, and about half that on the grade. The cars of the express trains carry 50 passengers and the local cars each 64 passengers.

The trolleys which take the 3,000-volt current direct to the motors consist of two copper rollers, each 16 inches long and having a diameter of three and one-quarter inches. These rollers are mounted in the same axial line and have

steel ball-bearings. These bearings, however, do not have any current passing through them, it having been found in all trolleys with ball-bearings that the passage of the current through them soon pitted and roughened the surfaces. To the left and right of these pairs of rollers are copper cones about eight inches long, rigidly attached to the trolley support. The base of the trolley is supported on the top of the car, and has a long horizontal hinge, and the trolley is connected to the piston of an air cylinder supplied by the air-brake apparatus on the train, so that the trolley can be readily raised and lowered, a dash-pot preventing jar.

Each of the primary or high-tension motors has its trolley with double rollers. The current is taken from the two rollers by collecting brushes running in contact with graphite collars, against which they are held by spiral springs. The current is taken from these trolleys by highly insulated wires inside of grounded metallic tubing, 3,000 volts being supplied direct to the motor. Each car is mounted on two four-wheel trucks, and is equipped with two "primary" and two "secondary" induction motors, there being in all four motors of 150 horse power each.

The motors each weigh about $1\frac{1}{2}$ tons. The air gap is only between four and five millimeters.

In starting up a train or climbing up a grade the motors are connected in "cascade"; or, in other words, while the 3,000-volt current is direct connected to the stationary windings of the "primary" motors, the windings of their "rotors," which are designed for 300 volts, are connected to the stationary windings of the "secondary" motors, while their "rotors" are in turn connected to a fluid resistance. This arrangement gives a speed of about $18\frac{1}{2}$

miles per hour. The controller is thrown to but two positions—i. e., half speed and full speed.

When the handle of the controller is thrown to the second or full-speed position the stationary fields of the two "primary" motors are then thrown directly on the line, and their rotors are connected to the fluid resistances, which are slowly cut out of the circuit. In the meantime the "secondary" motors have been cut out of the circuit. This full-speed arrangement gives approximately $37\frac{1}{2}$ miles per hour.

The controllers at each end of the car are connected mechanically, and the high-tension switches are connected electrically. A special device renders it impossible for any one to open the boxes containing the high-tension switching apparatus until a key has been removed from the trolley device, and this key cannot be removed until the trolley has been lowered and the circuit thus opened, rendering it perfectly safe.

The high-tension switches carrying the 3,000-volt primary current consist of a horizontal iron plate pivoted on a vertical shaft ending in a rack which engages a pinion worked by a crank. The plate is raised by turning the hand crank, this plate having six porcelain-backed bolts with steatite heads mounted on the upper side.

The collecting current circuit is connected to three copper sockets sunk in porcelain insulators, the cables of the three motors being similarly connected to three sockets. All of the six sockets are directly above the plates, which are raised by the plate.

The insertion of the bolts into the sockets establishes a perfect connection, and on their withdrawal a rarefaction of the air is produced, which to some extent prevents the formation of an arc, which is further assisted by the steatite heads.

Reversal of the current to the motors may be effected by rotating the lower switch-plate on its vertical axis. A relay placed in the return circuit to the rails causes a cutting off of the current to the motors by lowering the switch-plate should a safe limit be exceeded.

A special device is also provided in case of the potential falling, due to a break in the line, by means of which device the 3,000-volt trolley circuit is grounded.

The arrangement employed on this line is such that it is impossible for two trains to move upon the same section of track in the same direction at the same time, as each train leaves the section behind it dead, re-establishing the circuit as soon as it has passed into the next block.

The signalling system employed, when set against an approaching train at the same time cuts off the current from that particular section until the train is given the right of way.

The brakes on the train are also automatically applied the moment the train endeavors to enter a section over which the preceding train has the right of way.

During the entire time of operating this road but one accident has occurred, and that due to a workman forcing the door of the high-tension box open, and thus somewhat severely burning his arm.

The wires of both the field and rotor windings pass longitudinally through insulated tubes in the iron. The ends of the winding are insulated by mica and protected by plates or caps bolted on, and the windings are all invisible.

The motors are direct connected to the axles. By this I mean no gearing is employed. The axle of the rotor is hollow, the internal diameter being eight inches, and is lined with brass. The

car axle, which has a diameter of four inches, passes through this hollow axle.

The circuits to the three collecting rings pass through grooves in the rotor shaft, and the rotor shaft and car wheel are flexibly connected, thus preventing jarring and vibrating. The smoothness with which these trains were started and stopped is remarkable.

At one end of the rotor is a driving flange, which is connected to the driving wheel on that side of the motor through two links, one of which acts by thrust and the other by tension, the two stresses being of equal magnitude; at the other end of the rotor the three collecting

rings, upon which rest the three carbon block brushes supplying current to the rotor.

A 100-volt three-phase motor is supplied with current through an 8-kilowatt transformer connected to the line, and is used for compressing the air for the air brakes, for raising and lowering the fluid in the resistance boxes, and for raising and lowering the trolleys and automatically operating the high-tension switches.

A circuit from the same transformer supplies current for lighting the train. It was found that the low periodicity of 15 per second caused such noticeable

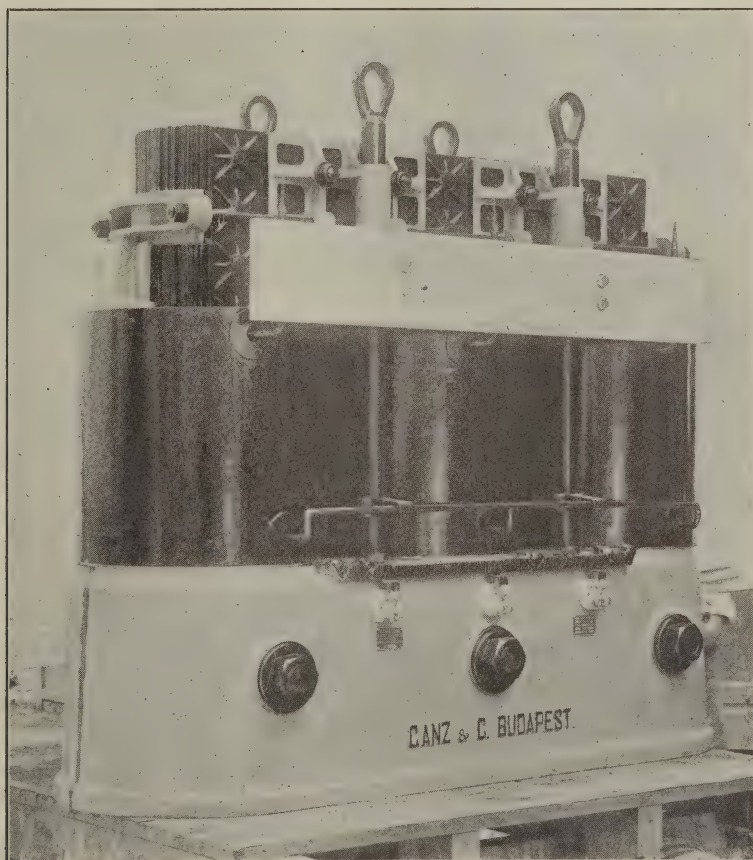

Ganz Transformer Used on the Valtellina Railway.

fluctuations in the light of the ordinary incandescent lamp that three-phase, or three-filament, lamps were made by both the Cruto and Ganz companies for this purpose, and are being very successfully employed. I saw lamps of both of these types tested on the circuit, and the three-phase lamps were remarkably steady, while the others were not.

The liquid rheostat employed on these cars is very ingenious, and has given very satisfactory service. It is a three-phase rheostat, and consists of an iron box with three wings to it, from the top of which depend three separate cylinders. Inside of each cylinder are two sets of iron plates, which are rounded at the lower extremity and vary in length. The alternate plates are connected in pairs, the current entering by one plate and leaving by the other, the sets being attached to the three phases of the low-tension roller circuits, which have a potential of only 300 volts. A cooling device is attached to these rheostats.

The solution employed is sodium carbonate, contained in the lower portion of the outer case. The upper portion of this outer case is supplied with compressed air, which, on being supplied to the case, in a greater or less degree, allows the solution to rise in the three cylinders. In rising, the liquid comes in contact with the iron plates, one after another, thus cutting the resistance out of the circuit to a greater or less degree, dependent upon the height of the solution.

This plan, it will be readily seen, is much simpler and far preferable to the raising of the plates out of the liquid.

The device is the result of extensive experimentation, and permits the motor-driving torque to be kept constant during acceleration. The entire height through which the solution passes is less than a foot.

The exhaust valve is the lift type of valve, normally kept open by a spiral spring, and the valve for operating the rheostat is compound wound, having several openings through it. On being operated the compound valve first opens a clear way for the compressed air to the cylinder and to the top of the piston, which compresses the spiral spring of the exhaust valve already referred to and closes this exhaust valve. The air then slowly passes through a small throttled aperture, admitting the air to the outside of the resistance box casing at a low pressure.

When half speed has been attained the motion of the trolley lever when thrown to full speed causes the air-cock to close the throttling aperture, opening another aperture, and thus relieving the air above the upper surface of the exhaust valve piston, permitting the compression spring of this valve to instantly open, it thus throwing in instantly the whole resistance.

The operations described are repeated in securing acceleration from half to full speed, and in securing retardation from full to half speed, at which time the motors operate in "cascade," as already described.

The Arcioni three-phase recording wattmeter, manufactured by Camille Olivetti, of Ivrea, Italy, is employed to register the entire output of the Morbegno plant. This wattmeter, I found, is being used extensively in various high-tension plants throughout Europe, and is giving very great satisfaction. I know of no instrument for this class of work which has given as satisfactory results. No oil switches are employed in this plant, ropes being used to pull the levers attached to the high-tension switches overhead, and to these are attached Siemens' horned lightning arresters.

I was informed that no lightning has

ever entered the station, and the protection is doubtless due to the very interesting lightning arrester. Three jets of water are thrown into the air, each jet coming within a short distance of a tap taken from one of the three-phase lines of the high-tension circuit. Any lightning disturbances passing over the line will jump across the intervening air space and pass through the water to the ground. The device is most simple, and thus far has proved very effective.

In preparing the data on this most interesting engineering development I am very much indebted to Director Otto F. Blathy and Mr. Kando, chief engineer, to whom the success of this system is largely due, and to Mr. Lello Pontecorvo, one of the engineers of the Ganz company, in charge of the work, who very courteously took me over the road, through the power-house, etc., and furnished me with many of the engineering details.

A Forty-Foot Modern Launch

By F. SANFORD ANDERSON

THE accompanying plans show a type of modern launch, designed to meet the requirements of the up-to-date launch owner—comfort, speed, and sea-worthiness.

She is to be of the torpedo boat style, so much favored by builders of speed launches. Her dimensions are as follows: Length over all, 40 feet; beam, $6\frac{3}{4}$ feet; freeboard at bow, $3\frac{1}{2}$ feet; freeboard at stem, 2 feet; draught, $2\frac{1}{2}$ feet.

The keel is constructed from a single selected piece of hard Western oak 3 by 6 inches, and the ribs of hard Western oak 2 by $1\frac{1}{2}$ inches.

The planking is yellow Southern pine $1\frac{1}{8}$ inches in thickness. The deck is made of either mahogany or white pine 1 inch thick. The sides of the house are of oak, and its top of half-inch cypress covered with canvas.

The cabin is divided into three compartments—stateroom, engine room, and

saloon—and is finished in mahogany and oak, with plate-glass windows. The stateroom and saloon each have two folding berths, which take up very little room when not in use. The pneumatic cushions are to be used as mattresses when the berths are in use, and, on occasion, may also serve as life preservers.

The steering wheel is forward in the stateroom, and a rolling curtain may be drawn down, converting the forward part of the stateroom into an inclosed pilot house.

In the engine room, on the port side, is an asbestos and zinc or porcelain lined ice box, galvanized iron water tank, and the closet. This latter has a door opening into the stateroom, and is fitted with a Sand's toilet and folding lavatory, the latter having a pump similar to those used in Pullman cars, connected with the fresh water tank.

The saloon has a swinging table, which may be raised out of the way to the

roof when not in use. Lockers for dishes, cooking utensils, and provisions are provided under the seats of this compartment, and forward, in the state-room, are lockers for bedding, clothing, etc.

For power the boat is to have a 16-horse-power electro-gasoline engine, built by the International Gas Engine Company, of Mariner's Harbor, Staten Island, N. Y.

The shaft, propeller and rudder are all of bronze. The engine is fitted with bilge and circulating pumps, and an air pump, which maintains a pressure of 75 pounds to the square inch, in a galvanized iron cylinder, for use with the whistle. The engine has a set of eight large-size Edison-Lalande batteries, and a dynamo for sparking purposes. Gasoline is supplied from a tank in the bow holding 200 gallons. This tank is very carefully constructed of copper to prevent any chance of gasoline leakage. The engine consumes one pint per hour per horse power of gasoline, or two gallons per hour when running at full speed. The cost of this would be about 25 cents an hour.

The launch is designed to give a speed of 12 knots, or about 13 2-3 miles, per

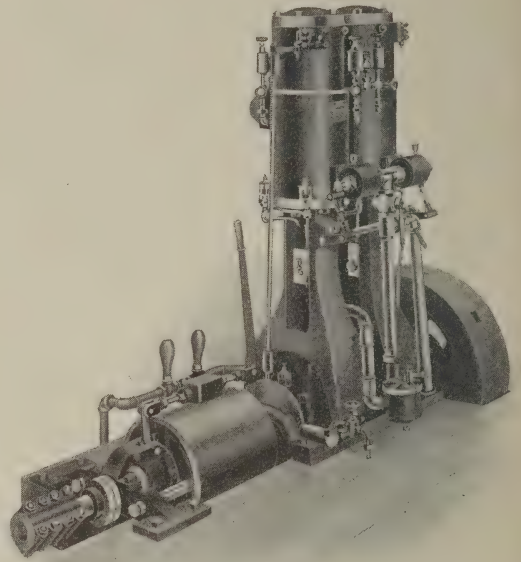

International Marine Gasoline Engine.

hour, with a 16 horse-power engine, and was designed by the writer at West Haven, Conn.

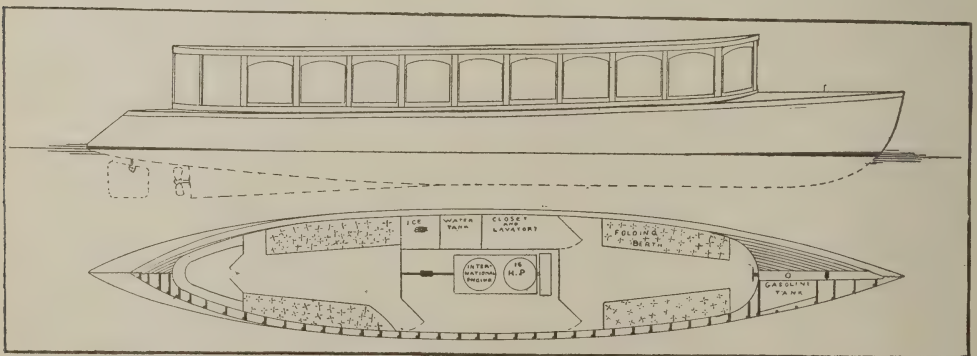

Design for a Modern 40-foot Launch.



Digest

Engineering Literature of the Month



Electric Haulage on an Ohio Canal.

(*Street Railway Review.*)

A SYSTEM of electric haulage for canal boats is being installed on the Miami & Erie Canal which is not only unique in the history of transportation, but involves the use of a three-phase system of electric traction, being the first electrical installation of its kind in this country, and the most extensive application of mechanical canal boat haulage in the world.

The Miami & Erie Canal runs from the Ohio River at Cincinnati in a general northerly direction, and connects with Lake Erie at Toledo. The electric system which is being installed, and which is now practically completed between Cincinnati and Dayton, a distance of 68 miles, comprises a standard-gauge single-track road built along the tow-path of the canal on which electric locomotives are used to tow fleets of from five to seven canal boats.

The canal, which was begun in 1825, had at one time paid large receipts to the State, but during the last 20 years most of its business has been diverted to the railroads, so that the appropriations for its maintenance included not only all of the receipts, but often considerable amounts in excess taken direct from the State treasury. It is believed that the large amount of business formerly done will be largely reclaimed by the present company, as the business in sight from the old-established concerns along the

route will be more than sufficient to tax the total capacity of the new installation, which will be 100 boats a day between Cincinnati and Dayton.

The inception and promotion of the present scheme of electrical haulage on the canal is due to Mr. Thomas N. Fordyce, who was engaged for several years in making experiments in this direction on both the Erie Canal, New York, and the Miami & Erie Canal in Ohio. In 1900 Mr. Fordyce entered into an agreement with the State Board of Public Works of Ohio to undertake a series of experiments whose success proved the feasibility of this system, and a contract was entered into between the State of Ohio and Mr. Fordyce in March, 1901, granting him the right to construct and operate along the Miami & Erie Canal and upon the land adjacent, belonging to the State, all necessary facilities for propelling boats by means of an overhead trolley system built upon the tow-path, from the time the system is put in operation, and it specifies, among other provisions, that the construction of that portion of the route between Cincinnati and Dayton shall be completed within two and one-half years from the date of the contract, and that the entire length of the canal must be completed within four years thereafter. Failure to comply with these provisions forfeits the franchise.

To the Miami & Erie Canal Transportation Company was assigned the contract between the State of Ohio and

Mr. Fordyce. According to this franchise the company, if obliged to abandon its project for any reason, shall have the right to remove all of its poles, wires, tracks, and buildings from along the canal; the State of Ohio, out of its appropriations, maintains the canal.

According to the terms of the franchise the entire track between Cincinnati and Toledo, a distance of 244 miles, is to be finished and in operation by the year 1907. The part of the work between Cincinnati and Dayton and through the latter city, a distance of 68 miles, which was to be completed in two and a half years from March, 1901, is already practically finished. The roadbed, which is laid with seventy-pound rails on oak ties, follows the bank of the canal. It is very substantially constructed, and where the locks occur trestles are built from the high level down to the low level, so that the grades have been maintained within a maximum of $1\frac{1}{2}$ per cent.

Turnouts are provided at suitable points for passing locomotives, the switches and frogs being furnished by the American Switch and Frog Company. The rails are bonded with United States Steel and Wire Company's bonds, one to each joint, and there are no cross bonds. In a number of places where the road passes under bridges the roadbed dips down below the surface of the water in the canal, and at these places concrete retaining walls have been built. The high tension feeders are run in the form of a triangle, two phases being carried upon the lower cross arm and one on the upper cross arm centrally above the other two. These are carried on Locke porcelain insulators of the Victor type without gutters. The feeders are stranded aluminum wire, equivalent to No. 0 copper. The three-phase circuit for the locomotives is carried on two overhead trolley wires and the track.

On account of the numerous bridges under which the trolley wires have to pass, the height of these wires above the track is very variable, being 22 feet high in some places and as low as 7 feet under some of the bridges in the city of Cincinnati. The minimum height of the trolley wires outside of the city is 9 feet.

The trolley wires consist of two No. 0000 G. E. groove wires carried for the principal part of the way on Christy flexible brackets, with special double insulated fittings made by the Ohio Brass Company. At swing bridges and places where it has been necessary to run the high tension feeders on the side of the canal opposite to the tracks, to avoid buildings and other obstructions, span wire construction has been used.

The company has no generating station of its own, but takes current from the Cincinnati Gas and Electric Company, which has a plant on the bank of the canal near the Cincinnati terminus. This company furnishes three-phase current of 60 cycles at 4,000 volts pressure to the Spring Grove converter station. This current is stepped down to 400 volts at the Spring Grove station and is two-phased by the Scott method of connection of transformers. This two-phase current is led to a 450 horse power two-phase synchronous motor, which is direct connected to a three-phase, 25-cycle, 300-kilowatt generator, giving a pressure of 390 volts. Thence the current is led to 250-kilowatt transformers and stepped up to 33,000 volts for the transmission line. At points about 12 miles apart there are static transformer substations, each of which is to be equipped with three 150-kilowatt transformers permanently connected in delta. These transformers will step the three-phase current down from 33,000 to 1,090 volts, which is the voltage of the trolley circuit.

The company has at the present time seven locomotives contracted for, four of which have been already delivered. These are each twenty-ton locomotives, the frames of which were built by the Baldwin Locomotive Works and the equipment was furnished by the Westinghouse Electric and Manufacturing Company. The cabs of six of the locomotives are built so as to clear the trolley wires at a height of 9 feet, and one locomotive, which is to be used entirely for switching purposes in the city of Cincinnati, is built to pass under trolley wires 7 feet high. The frames, which are 14 feet in length, are mounted on Baldwin trucks having 30-inch wheels and a 7-foot wheel base. The weight complete is about 24 tons each, and the motors are connected to the axles through double reduction gearing. The draw-bar pull with three-phase current at 3,000 alternations and 1,100 volts, and with an efficiency of 95 per cent. for each pair of gears, is as follows :

Coefficient of Adhesion.	Draw Bar Pull.
25 per cent.	9,600 lb. starting.
20 per cent.	7,600 lb. starting.
16 per cent.	6,350 lb. starting.

That part of the trolley circuit inside the city of Cincinnati will be operated at a pressure of 390 volts, as a precaution of safety, instead of 1,090 volts, and the locomotive transformers are provided with auxiliary connections to utilize this voltage inside the city. Changes in the transformer connections will be made by means of switches in crossing the city line.

Rapid Work in Running Telephone Wires and Cables.

(Electrical World and Engineer.)

An illustrated description is given of the method employed by the Home Telephone Company, of the Pacific coast, for running telephone wires and cables. By

this method 10,000 feet of cable are pulled per day with a gang of seven men, while in the East a gang of nine rarely makes more than 3,000 feet.

To begin with, the reel is mounted at the store yard or freight house upon a couple of broad-tired wheels and swiftly rolled or pulled by horse power to the manhole, where installation is commenced, and instantly dropped into place. At the other end a really modern pulling engine is set. This consists of a substantial iron frame truck, upon which is placed a hoisting machine with differential gearing and two drums, driven by means of a three horse power 500-volt electric motor, controlled by a variable rheostat. One side of the motor is grounded upon the truck, while on the other side a heavily insulated flexible cable proceeds to a hook, mounted upon a long wooden handle, that can be instantly attached or detached to a neighboring trolley wire. The wattmeter is included in the cable circuit, so that the amount of energy demanded by the pulling engine is always recorded. The hemp rope is replaced by a quarter-inch flexible steel strand that is coiled three or four times about one of the drums of the engine, and passes to the hands of an attendant, who thus has the most sensitive conceivable control over the pulling of the cable and can stop its motion within the fraction of an inch. He can, in fact, feel it move and accelerate, retard or stop its motion as the case may demand.

For running aerial lines the following method is used: A special iron wagon, consisting of a stout channel iron frame, placed upon four broad tired wheels, is provided. There are two longitudinal bars, each of which is equipped with five wrought iron pipe reels, so designed that a coil of hard-drawn copper wire may be dropped on to the reel and unwound without kinking. The cart is hauled to

one end of the line, and a pulling rope, a couple of thousand feet in length, extended over the cross-arms of the poles. One wire from each reel is mounted in its proper hole in a running board, to which the pulling rope is attached. A horse at the other end of the rope furnishes necessary power and strings ten wires simultaneously, so that some five miles of wire are erected at a single pull. When a coil is exhausted a MacIntire joint splices on a new coil, and the process continues until all the desired wire is in place. Where more than one cross-arm exists a split running board is used for the lower arms and wire strung with equal speed.

While the process of installing cable in conduits here described entails an expense for some special apparatus, this should in most cases be recouped many times by the saving in the labor bill. Where dependence cannot be placed on trolley circuits for a supply of power a gasoline engine could be employed, or a steam engine of the standard portable type mounted on wheels, together with the necessary hauling-in gear.

Lightning Phenomena.

(Monthly Weather Review.)

Prof. John Trowbridge, Cambridge, Mass., says the "Western Electrician" calls attention to the fact that low-lying clouds heavily charged may possibly sometimes discharge electrically to the surface of the large body of water like the sea; but he believes that his experiments show that at the average altitude of thunder clouds the tendency is to discharge from one region of cloud to another in preference to discharging to the sea. The testimony of persons who claim to have seen lightning strike the sea is not very reliable, since most persons are ignorant of the phenomena of irradiation; they are confused by the blinding flash

and mistake reflection in the water for the flash itself.

He adds: "By means of a battery of 20,000 small cells a voltage of about 6,000,000 is obtained, which is at least comparable to that of lightning. With this large battery I was able to obtain an electric spark about seven feet long, and found that instead of striking the water a spark of six or seven feet in length invariably jumped to some adjacent object in preference to striking the liquid surface. A spark of only a few inches in length, however, will strike the water, but such a spark is not comparable to lightning. Beyond a million volts the initial resistance of atmospheric air to electrical discharges becomes less, and the discharges, therefore, are shunted through the air instead of upon the water, and strike some object adjacent to the water."

Location of Switchboards.

(Street Railway Journal.)

Ernest Gonzenbach, in an able series of articles on "Engineering Preliminaries for an Interurban Electric Railway," states that several very modern plants of recent design have the switchboard on the high-tension side of the transformers, and there seems to be a tendency to follow this practice. Its advantages are many when the current is generated at high voltage in the machines and it is desirable to take the current from machines to lines with a minimum of high-tension wiring. When the line voltage is beyond the limits of generator voltage then it seems that the introduction of the switchboard in the high-tension side of step-up transformers incurs a large amount of unnecessary expense and complication of apparatus, and it seems, moreover, that such practice is out of place in an up-to-date plant. In order to simplify the station wiring it is

also advisable to locate the switch-board on the station floor and avoid the annoying and expensive switch-board gallery, which has no "raison d' être" except in the very largest power stations. In this connection it is well to observe the practice of handling high-tension currents in use in the power transmission plants on the Pacific coast, where longer experience has been had than elsewhere in that particular class of work. They handle currents almost exclusively from the low-tension side, and give excellent reasons for so doing, and the practice of using complicated and expensive high-tension switching devices has few advocates among those concerns, which have made the business of power transmission what it is.

Best Methods of Feeding Boilers.

(American Manufacturer.)

In describing a number of methods of feeding boilers, D. B. Dixon states that the method now generally recognized as being the best and superior to any hitherto employed, and adopted in all new large steam power plants, is that originated by the Hartford Steam Boiler Insurance Company and described as follows: The feed pipe enters the boiler through the front head just above the top row of tubes and about three inches from the shell; then passing back to within a foot or eighteen inches of the back head, and crossing over to the other side of the boiler. It then passes down between the tubes and the boiler shell. In the vertical pipe first mentioned are a stop valve, a check valve, and a union. With this arrangement the fireman is not compelled to leave his post in order to regulate the supply of feed water. The advantage of this method lies in the fact that before the feed water discharges it has become as hot as the water into which it is discharged, consequently there

is no chilling effect produced and no unequal expansion and contraction of the boiler. Brass pipe is preferable to iron pipe in an arrangement of this kind because it is a better conductor of heat, and it will not choke with scale as quickly. There is some trouble in getting the pipe out of the boiler in order to clear it when it becomes choked, but as an engineer's troubles are various and many, this trouble when mixed up with the others will not cut much of a figure. The piping can be so connected that only the portion running across the boiler need be taken out, while the long section may be cleaned in place by running a long iron rod through it.

When a boiler is used for heating purposes and steams very easily, it does not make much difference whether it is fed continuously or not, but a boiler generating steam for power should be fed continuously, otherwise the water level becomes low.

Aside from the ill effects of expansion and contraction—when the method of feeding causes these—and the danger of having the water supply shut off when it is in this condition, when the feed-water is again started it must be introduced in larger quantities than if fed continuously. The feed water entering the water in the boiler when its volume has been reduced, as at the time of "pumping up," has a greater tendency to rapidly cool the water in the boiler. This invariably requires heavy firing to maintain the steam pressure. The result is that more coal is burned than would have been necessary had the feed water been introduced as fast as it disappeared in the form of steam, or by a continuous feed.

Notes on X-Light.

(Electrical Review.)

In a series of illustrated articles published under the above caption, Mr. William Rollins gives some valuable infor-

mation regarding the latest and best methods at present employed in X-ray work. Among other things, he states that it is often necessary in making a diagnosis with the cryptoscope to vary the distance of the source of X-light without removing the eyes from the image on the fluorescent screen, as, for example, to get a preliminary idea of how far below the surface a foreign body or aneurism is, and to know at any moment the distance of the source of X-light and how much it has been moved to allow the variation in the shadows to give us the information we desire.

If a physician is provided with a tube box, mounted with the central ray marker, distance and position finder attached to the diaphragm plate and controlled as shown, this can be done by mounting a non-radiable scale along one edge of the fluorescent screen. It then is only necessary to move the screen until the image of the central ray marker comes into convenient relations with the scale. The diameter of the image on the screen of the distance finder shows at once the distance of the source of X-light, and by noticing how fast this changes, as the source of X-light changes, and observing at the same time the change in dimensions of the shadow of the object under investigation, the relative changes give information in regard to the distance below the surface at which this object is situated. The scale is best made of a strip of lead notched at intervals of ten millimeters, with smaller, or millimeter, notches between.

•

Fuel Economy.

(The Engineer.)

Saving in labor in the boiler room by the use of mechanical appliances is often reckoned as the saving of so much fuel. Yet the burning of slack coal by the aid

of the automatic stoker and the combustion of coal dust in blasts of air driven under pressure into boiler furnaces are some of the methods of latter-day practice which can more truly be classed as fuel economy. In other words, it can be said that the true fuel economy is that which effects an actual saving of coal, whether it consists in the evaporation of more water with a given amount of coal or in some method for burning waste products which might otherwise be unavailable. This not only tends to effect a saving for the power user himself, but at the same time tends to lessen the total amount of coal consumed in the country for power purposes, and, under the universal action of the law of supply and demand, the price of coal will then tend to fall. In this connection it might be said that, in addition to the utilization of slack and coal dust as fuels, with the consequent decrease in the price of the better grades of coal, the thousands of square miles of peat beds which underlie considerable portions of our country may make the price lower yet, as the present indications are that at least a possible substitute for coal will soon be produced by briquetting this material. This appearance of new fuel supplies is highly gratifying at the time when all other conditions are tending to continually increase the value of coal, as the consequence of an unlimited advance in the price of this most necessary fuel would be fearful to contemplate. To realize what the result would be it is only necessary to consider for a moment that great part of our country which we are pleased to call the West. In the Rocky Mountain regions and that fertile tract of country which borders the Pacific coast, there has, until recent years, been practically no power, owing to the scarcity of coal. We are now amazed at the rapid industrial development which is taking place

there since the advent of long-distance transmission of electrical energy has made the country's great resource of water power available, and the almost simultaneous discovery of the great oil fields of the South and West has brought into the field a mighty competitor of coal.

Boiler room economy would not be very effective if the price of coal should advance so fast as to neutralize all the gain resulting from the economy. It is well, then, to direct a part of our attention, at least, toward the development of substitutes for coal, with the consequent increase of supply to meet the increased demand. Then the small percentages which we gain by boiler room economy may count for something.

Spanning of the Pacific by Wireless Telegraphy.

(The American Inventor.)

Waldon Fawcett states that plans and specifications for the erection of wireless telegraph stations in California, Honolulu, Manila, and Hong Kong, with a view to spanning the Pacific Ocean by wireless telegraphy, are now complete, and if the actual work of construction is commenced, as contemplated, within the next few weeks, it is hoped to have the stations well along toward completion by the spring of 1904.

The range from Manila to Honolulu is the longest and most difficult in the world, and plants for generating 60 kilowatts are laid out for these stations. At each station three towers, each 250 feet in height, will be erected in a locality as near high-water mark as possible. In the triangular space between the towers will be located the buildings for power house, receiving and relay offices. The power at each of these stations will be generated by steam, a

full plant of boilers and turbine steam engines being provided. The engines will be coupled direct to three 20-kilowatt generators of 40 cycle frequency, and of a design to furnish a wave of peculiar form.

A feature of the preliminary plans, which will doubtless prove of especial interest to electrical engineers, is found in the comparatively low potential generated by the transformers. The maximum will be 25,000 volts, since by the peculiar form of tuning capacities invented by De Forest this potential has been demonstrated to have the carrying capacity of voltages several times as high. This low potential has the advantage of rendering the securing of efficient insulation an easy matter, and the even more valuable property found in the prevention of the discharge of the aerial conductors by bright sunlight. It is claimed that the solution of this problem obviates what in the Marconi long-distance installations is a serious drawback, rendering it impossible at times to transmit signals for 2,000 miles, save at night. The removal of this obstacle in the system to be introduced on the Pacific and in southern waters is especially essential, from the fact that in the tropics the factor above mentioned is particularly serious in its effects.

Simultaneously with the erection of the Manila and Hawaii stations a smaller one will be erected at Hong Kong, China, to work with the Manila station. This mainland station will require but 20 horse power, and will obtain its energy from a kerosene oil engine. The towers will be 175 feet in height. The American terminal will be located near the southern end of the peninsula of Lower California, a locality on the line of the great circle with Hawaii. Here the two towers will be similar in construction to those at Manila, and each will have a height of 210 feet. The power required

to transmit across the first stretch of the Pacific is estimated at 45 kilowatts, and, in the case of this station also, energy will be furnished by steam engines and a battery of boilers for steam generation. At each of the four stations the electric waves radiated will have a wave length of one and one-half miles. This relatively excessive length has been selected after careful calculation and experiment as the best adapted for long-distance transmission. It is argued that the longer wave length will traverse obstacles and have less liability to dissipation than short wave lengths.

The Use of Oil in Smelting.

(*Engineering and Mining Journal*.)

At the Selby Works, California, Mr. Alfred Vander Rapp has been very successful in applying crude oil to smelting purposes. He finds that a matting furnace, which ordinarily requires one ton of coal for every three and one-half tons of ore, will smelt a ton of ore per barrel of oil, so that three and one-half barrels of oil are the smelting equivalent of one ton of coal, in a locality where coal costs \$6 per ton and fuel oil 80 cents per barrel. Under the prevailing conditions the use of oil represents an economy of 50 per cent. Besides this economy of first cost, the oil fuel has been found advantageous because the oxidizing atmosphere of a roasting furnace can be maintained without those interruptions which take place when fresh coal is added—interruptions which are accompanied by the introduction of reducing gases which temporarily cause the process of oxidation to remain at a standstill. Moreover, it is possible with oil, by regulating the air inlet of the furnace, to control the smelting atmosphere so as to obtain oxidizing or reducing conditions, as the metallurgist may desire. The ability to in-

crease the temperature of a metallurgical operation with notable ease is another good feature.

The Miner's Inch.

The so-called "miner's inch," which has been variously described by different writers, is substantially that quantity of water which will flow through an aperture one inch square, the water being at rest, and its surface six inches above the top of the aperture. To those engaged in placer mining the following table of time and quantity of water flow through a miner's inch may be of service:

	Cubic feet.
In 24 hours will flow	2159.1360
In 1 hour will flow	89.9640
In 1 minute will flow	1.4994
In 1 second will flow02499

—*Exchange.*

Ingenious Belt-Shifter Carrier.

A simple and most ingenious belt-shifter carrier designed by the general foreman of the P. & R. shops at Reading, Pa., may be seen by the observant visitor, or will be gladly shown to others on request. The carrier can be put in any position or at any angle, and will work as well standing on its head as it will in the conventional position. It consists of two separate arms, each terminating in a flat disc perhaps four inches in diameter. On one side of each disc is cast a number of radiating V-shaped ribs. When these two discs are properly bolted together the V-shaped ribs engage and preserve the angle at which the two arms may have been placed. To alter the angle, the slacking of a nut will allow for new adjustment. One arm is secured to the post, the other holds the belt-shifter and the carrier falls in pleasantly with any angle which circumstances may demand. —*Locomotive Engineering.*

The Electrical Age

Incorporated April, 1902

CHARLES A. LIEB, - - - - PRESIDENT

New York, May, 1903

Volume XXX

No. 5

Published Monthly.

Subscription, \$1.00 per year. Single Copies, 10 Cents.
(\$2.00 Per Year to Foreign Countries.)

20 BROAD ST., NEW YORK. Telephone 1628 Cortlandt.

THE ELECTRICAL AGE (Incorporated)

Entered at New York Post Office as Second Class Matter.
Copyright, 1902, by THE ELECTRICAL AGE.

TO ADVERTISERS

Changes for advertisements and new advertisements **must** be in this office by the **20th** of the month to be included in the issue in the month following. The advertising pages carry printed matter measuring five and a half by eight inches. Cuts intended for use on these pages should be made to accord with these measurements.

Correspondence and semi-technical articles, with suitable photographs for reproduction, or cuts, are invited. Accepted matter will be promptly paid for. We cannot be responsible for any unsolicited manuscripts, but when stamps are enclosed all unavailable matter will be returned. Postage must always be fully prepaid. Cuts to be available for illustrating articles must conform to the column or page measurements. The columns are $2\frac{1}{2}$ inches wide. Cuts for single column use should not exceed that width. Cuts to go across the page should not be more than five inches wide, and full page cuts may not exceed $4\frac{1}{2} \times 8$ inches.

AT the commencement of the present year an important step was taken for the establishment of local or branch meetings of the American Institute of Electrical Engineers in connection with universities and technical schools. These meetings are held, in some cases, under the direction of a professor of electrical engineering, and in other cases in connection with an electrical society or other organization conducted by the students themselves. The local meetings are held in connection with the following institutions: Massachusetts Institute of Technology, Union University, Lehigh University, Cornell University, Columbia Univer-

sity, Pennsylvania State College, Western University of Pennsylvania, Ohio State University, University of Cincinnati, Purdue University, University of Illinois, University of Wisconsin, University of Missouri, University of Minnesota.

Meetings of these branches, as well as other branches which have been formed by members of the Institute in different cities without any connection with educational institutions, are usually held ten days or two weeks after the monthly meetings at New York.

Experience shows that although students in these schools have become interested in this Institute, yet in many instances they are not prepared to join the Institute. For the purpose of extending valuable privileges of the Institute to these young men, and also to others who are looking forward to electrical engineering as a profession, it has been arranged that upon the payment of a very small fee, eligible students may attend the meetings of the Institute and receive copies of the meeting announcements and monthly Transactions, and also purchase the semi-annual bound volumes of the Transactions.

Upon the following conditions: First, indorsed by one member or associate of the Institute; second, recommended by the Board of Examiners and approved by the Board of Directors; third, payment in advance of the annual sum of \$3 for such privileges; fourth, enrolled by the secretary as a student of the American Institute of Electrical Engineers.

No student, however, shall have these privileges for more than three years, and these privileges may be withdrawn from any student, at any time, by a majority vote of the Board of Directors.

Belts, Pulleys and Shafting

By W. H. WAKEMAN.

SOME of the rules frequently repeated and apparently believed by millwrights, need revision, as they do not always work well in practice. Occasionally these rules, or ideas springing from them, find their way into print, where they appear at still greater disadvantage, because presented to more people.

For illustration, take that time-honored rule which informs us that a belt always runs to the high side of a pulley. I suppose that cases can be found somewhere in the broad field of the machinist and millwright where practice proves theory correct in this respect, but the exceptions to it are so numerous that they greatly overshadow the rule; therefore it would be better to adopt other rules and use this idea as the rare exception.

While still a young engineer, I noticed that whenever our shafting was reported out of line, as proved by belts failing to keep their proper place, the man who was expected to remedy the evil would watch one of these belts a few minutes, and finding that one or more inches of it did not touch one of the pulleys, would wisely state that it ran to the high side; therefore it would be necessary to lower the shafting on the side towards which the belt inclined.

Careful consideration of the matter fails to recall a single instance where lowering it as above mentioned had the

desired effect, yet it never appeared to shake the confidence of these men in their favorite rule.

As there might be conditions in these cases which were not known to me, that would explain the inconsistency, I set up two straight shafts with one pulley on each, and after carefully putting them in line, put a straight belt on them, and laced it so that where it was joined it ran perfectly true. These shafts were of course set level, therefore when one of them was turned, the other revolved and the belt kept in place nicely. See Fig. 1.

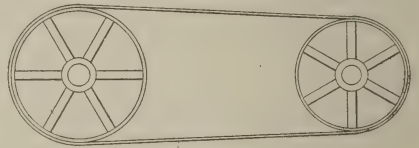

FIG. 1.

The next move was to raise one end of the driven shaft, thus making one side of the pulley higher than the other, but the belt did not run to "the high side," according to tradition, but kept right on where it was before, although the shaft was raised about 30 degrees from its horizontal position. See Fig. 2.

In addition to this result it may be added that I have never seen or known of one instance in a shop, mill or factory where leveling the shafting proved a remedy for belts running partially off their pulleys.

Another favorite fallacy is the idea that a belt always runs towards the edges of pulleys that are farthest apart. Fig. 3 is a plan view of two shafts that are level, in order to avoid any possible misunderstanding of the subject, but are

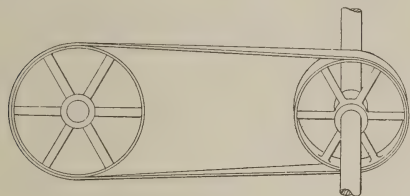

FIG 2

badly out of line. If the idea that belts always run towards the high side, or towards the edge of the belt that is drawn tighter than the other, were correct, then this belt would run off towards the ends of shafting that are four feet apart; but in practice it will not do so, for it comes off towards the ends that are three and one-half feet apart.

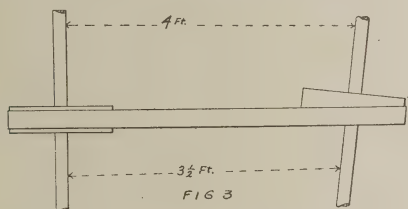

FIG 3

There is a perfectly logical reason for this, which is illustrated in Fig. 4. This is the plan view of a bicycle which is going in the direction indicated by the arrow, 2. When the rider wishes to turn to the direction indicated by the arrow, 3, he turns the front wheel in that direction, and the whole machine follows; but this is going towards the slack side of belt, assuming that the wheels carried a belt, and not to the high or tight side, as some people would have us believe.

This principle may be still further illustrated by Fig. 5, in which 2 and 3 are rollers on which a heavy plank, 4, is laid. So long as both rollers are at right angles to the plank it travels

straight forward when sufficient force is applied to move it; but when the roller, 3, is turned as indicated, does the plank go towards the ends of the rollers that are farthest apart? It certainly does not, but towards those that are nearer together; or, in other words, towards the slack side of the belt every time.

In the two preceding illustrations I assumed that if a belt was run on pulleys out of line, as shown by the bicycle and

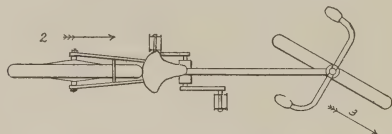

FIG. 4

the roller, said belt was perfectly straight throughout its entire length. If this belt is not straight, no intelligent rule can be laid down for determining where it will go to, and this fact is evidently a confusing element in the minds of some engineers.

The business of a certain saw and planing mill was discontinued and the equipment sold to different parties. A man who bought one of the belts reported that he could not make it run on the pulleys as he desired, for it would not conform to any rule that he was familiar

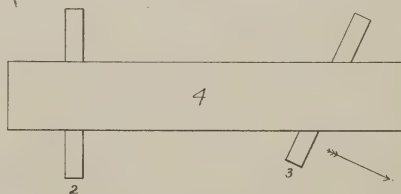

FIG. 5

with. When laid down on the shop floor, this belt appeared as shown in Fig. 6. This caused its former owner to remember that it formerly was a crossed belt, hence was useless in any other situation. Such a belt will run to the high, or to the low, the tight or the slack side, according to the way in which it is put on; but this proves nothing, and is un-

satisfactory so far as anything but a crossed belt is concerned.

Important changes having been made in the training school where I am employed, a ten-inch belt was put on a

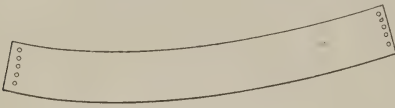

FIG. 6

counter shaft to run an exhaust fan, as shown in Fig. 7. This belt formerly ran horizontally, but in its new position stood at an angle of about 45 degrees. When the machinery was started this belt would not run centrally on the smaller pulley, but persisted in binding on the steel casing of the fan, which of course it was impossible to move. It was not practical to move the counter shaft, as it carried three other belts which kept in their places.

I took this ten-inch belt off, turned it "end for end" and put it on again, when it ran clear of the casing and has not been touched since. When this incident

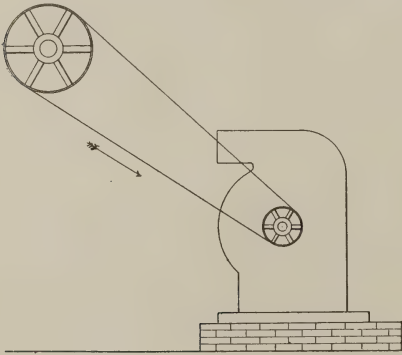

FIG. 7

is considered, what becomes of the rules about the high side of pulley attracting the belt, or the shafts being out of line? No change was made in either pulleys or shafting, yet with the belt running in one direction it could not be used, but reversing the direction of travel alone proved a remedy.

While writing on this subject I am reminded of an incident that occurred several years ago. A pulley with face 21 inches wide was wanted to drive a ten-inch belt, as it would be shifted from a tight to a loose pulley, and *vice versa*, on the driven shaft. Two pulleys of suitable diameter were found in the yard, and their combined width of face was more than sufficient. These two pulleys were put on it, as shown in Fig. 8.

This meant a long, disagreeable job, as the pulleys were each made in one piece; therefore it was necessary to take down the shaft, remove one of the couplings, and put the whole back again. Proper tools for doing such work were

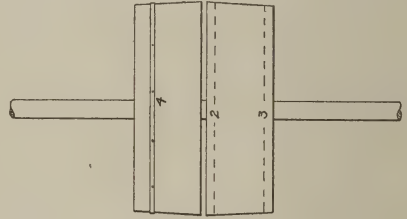

FIG. 8.

not available, but the job was finished and the machinery started the next day on time. The belt would run one-half on the tight, and the other half on the loose pulley, therefore there was not power enough transmitted to run the machine it was to drive, and it could not be stopped at pleasure according to the original plan. Careful investigation disclosed the fact that the diameter of the right hand pulley was greater at 2 than at 3, and the left hand one was made to match it. These two were formerly run as one pulley, made crowning at the center, hence the center of belt (regardless of its width) always went to that point.

To take the shaft down again and have the face of this double pulley made flat was out of the question at that time,

therefore a piece of three-quarter inch belt lacing was wound around the left hand pulley, as shown at 4. Small holes were drilled in the face of pulley with a breast drill, and the lacing fastened with copper rivets. The right hand pulley

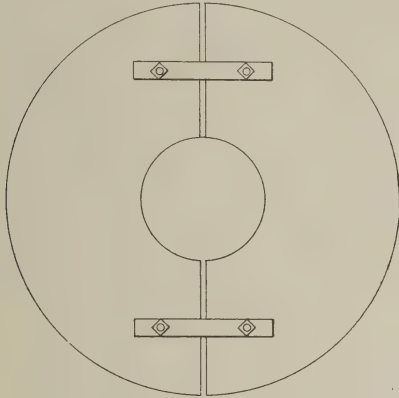

FIG. 9.

was served in the same way. This made the belt stay in place, but it required a considerable effort to shift it until the edge of belt struck the lacing, after which it would quickly go over to its proper place.

All this goes to show that a belt naturally works its way to the part of pulley that is the larger in diameter, provided the belt has an even tension; otherwise, across its entire face. Absence of this important requirement often shows in a crooked belt, but even this is not a cast iron rule, as a new belt may be perfectly straight, yet some parts of it will stretch more easily than others, thus showing an uneven tension.

When reading about the devices used to accomplish desired results, by men who for some good reasons were obliged to make the best of poor equipment, I am reminded of the "makeshifts" utilized in former days (now happily passed) to perform work and save expense, in my own case. One of these was a flanged pulley to prevent a belt from running off. The small jack shaft in our mill

was out of line with the engine, consequently when a heavy load was put on the main belt would commence to work off from the smaller pulley, and would come entirely off unless the load was reduced. To conclude that a flanged pulley would prove a remedy was an easy matter, but to get the pulley was a problem not easily solved.

Finally two disks were sawed out of hard wood planks, as shown in Fig. 9, and one of them put on each side of the pulley, as illustrated in Fig. 10. Bolts were then put through suitable holes, and by means of these the disks were held in place, as shown.

Hopes of ability to keep the main belt in place by this device were rudely shattered at the first trial, for as soon as a heavy load was put on it began to work towards the end of the shaft nearest the crank shaft, and coming in contact with

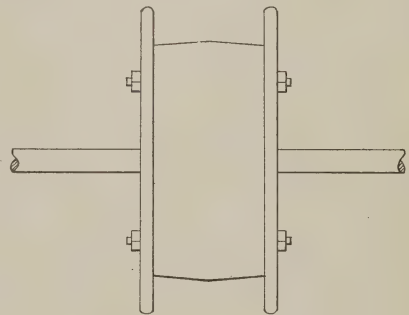

FIG. 10.

the flange it at once assumed the form shown in Fig. 11, nearly spoiling the belt and causing a hasty shut down.

Engineers and millwrights frequently claim that shafts should not be located comparatively close together, as the short belts thus made necessary must be kept very tight in order to transmit the required power, and this brings such severe strain on the boxes that unnecessary friction and heating of the metal results.

I am well aware of the fact that this undesirable state of affairs often exists

where short belts are used, but insist that it is not a necessary part of the program. Reasons for this conclusion are as follows: In order to transmit a given

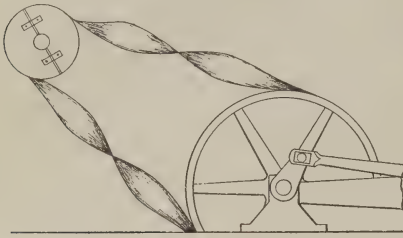

FIG. 11.

power, the tight side of a belt must sustain a certain stress per inch of width. Under equal conditions the required stress is secured by putting a certain tension on the slack side per inch in width. The latter may be secured by drawing a short belt tight, or by leaving a long belt loose, but it does not make the slightest difference with the box whether it is secured by one method or the other.

In either case the necessary tension may be exceeded and heating of bearings result, but this is sometimes due to excess of tension on the short belt over and above the actual requirements, and should be charged to error in judgment on the part of whoever estimated the length of belt, and not to the location of shafts. I am not an advocate of short belts, as a medium length is better in all cases; but the principle of condemning a plan because those who execute it are not competent and careful is not recommended.

Fig. 12 represents two pulleys, 24 inches in diameter, on shafts four feet from center to center. The idler on the slack side of the endless belt can be raised and lowered at pleasure, to secure any desired tension on the belt. This belt can be made to transmit as much

power, without excessive friction on the boxes, as any longer belt of equal width and thickness, both of same material, that was ever put on two pulleys. The only possible objection to it consists in the idler, which is simply an extra piece of machinery that is not required on a long belt, and is only used as a matter of convenience on a short one.

Much prejudice exists against idlers, but this is only another case where trouble is due to the misapplication of a principle and not to the principle itself. As an illustration of this point I will call attention to cases that are not

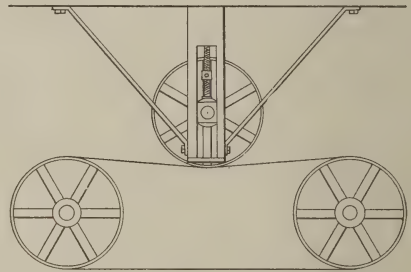

FIG. 12

uncommon where the pulleys revolve, say 600 times per minute, while the idler revolves 1,500 times; as, for instance, in wood-working machinery. The former are provided with self-oiling boxes, affording copious lubrication and requiring attention once in six months, while the latter is carried on boxes of the most primitive kind, that must be oiled at least four times in ten hours, and even then they heat badly. The remedy in all such cases is to make the idler much larger in diameter, and provide it with self-oiling boxes.

Of course all systems of belting and shafting are not equally efficient and convenient, but it is not right to condemn a system without qualification because it is disgracefully misapplied by ignorant and careless designers and workmen.



Between Whistles

Correspondence from Practical Men upon topics of interest to our readers are especially solicited for this column. Mechanics who have interesting experiences in handling Tools, Machinery, Engines, Boilers and other apparatus are also invited to contribute.

To the Editor, "The Electrical Age":

NOTICING the problem submitted by John Hewe in the current number of "The Electrical Age," who states that an engineer told him that a pump would lift water 19 feet with no more power than is required to lift it three feet, as the pump is, in any case, required to form a vacuum, and after that no more work is required of it, I beg to differ with the learned engineer, though I do not claim to be an expert on hydrostatics by any means.

In the explanation of my position below I will use round numbers, in order to avoid fractions, as the principle can be shown as well and more easily understood.

It is known that, if a perfect vacuum is formed in the lifting pipe, the pressure of the air on the outside will force the water up to a height of, approximately, 34 feet; but, as such a vacuum is impossible to attain in practice, let us assume that 24 feet is the greatest height which will be attained with a pump of average efficiency. Assuming the pressure of the air to be 15 pounds to the square inch, we would then obtain with the pump a partial vacuum in the supply pipe; that is, the pressure would be reduced to about 4 pounds on the inside of the pipe, as against the outside pressure of 15 pounds, which will cause the water to rise in the pipe until the weight of the water, added to the air pressure still remaining in the pipe, will equal the 15

pounds pressure on the outside, when the forces will be balanced and the column of water stationary, assuming that the piston is motionless.

Now it will be easily seen that, in order to lift the water to a small height like three feet, we have only to exhaust a small proportion of the pressure in the pipe, when the water will be forced up by the outside pressure to the required height; that is, we have only to lower the pressure inside the pipe three-twenty-fourths, or one-eighth as much, to get a lift of three feet as to get one of 24 feet, so that if a difference in pressure of 11 pounds is required for the former lift, the latter will only require one-eighth as much, or $1\frac{3}{8}$ pounds. It should be remembered that the water is not pulled up by the piston, but is pushed up by the pressure of air from the outside, so that the pump is in reality a force pump, which, instead of increasing the pressure from below, decreases that above, using the air to supply the pressure from below.

All pumps act by creating a difference of pressure between two sections of the pipe, and it makes no difference whether this is accomplished by increasing it on one side or by decreasing it on the other. An engineer who would state that a force pump would lift water to a height of 19 feet as easily as to one of three feet would probably not stand a very good show of getting a position as instructor in a school of technology, should he apply for one.

Regarding the inquiry of Ed. Rixon, I believe that if he will carefully examine a glass of the water referred to he will find that it becomes clear at the bottom first, gradually clearing from the bottom toward the top. I have noticed the same thing in water from the mains in some cities where the pressure is very heavy. It is caused by air which has in some

way been admitted to the pipes, and has been forced by the pressure into the water, in the same manner as carbonic acid gas is forced into soda water. In Mr. Rixon's case, it would be well to inform the agent of the building of the facts, so that he can charge the tenants extra for furnishing aerated water. They evidently do not appreciate a good thing when they see it. Would like to hear further from him to know if the trouble has been diagnosed correctly.

ERNEST F. DOW.

West Newton, Mass.

The Angulator.

It appears evident that most disinterested authorities strongly favor that a method of determining the real value of an incandescent lamp as a source of light should be by determining the spherical candle power of the

lamps by their spherical candle power is that there has not been an instrument by which the spherical candle power measurements can be taken at one reading that is not extremely complicated. To determine the spherical candle power by taking numerous readings requires considerable time and is, therefore, conceded to be uncommercial. These facts do not, however, alter the true condition, and the real value of the lamp cannot be determined in any other way.

Prof. C. P. Matthews, of Purdue University, is among the number who have devoted considerable time to the solving of this important question. Mr. Matthews has invented a very satisfactory apparatus for determining the spherical candle power at a single reading. The expense incurred in the ownership of one of these instruments is such, however,

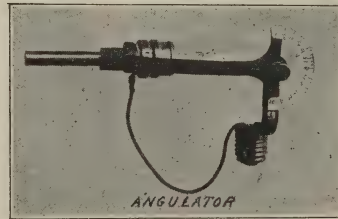
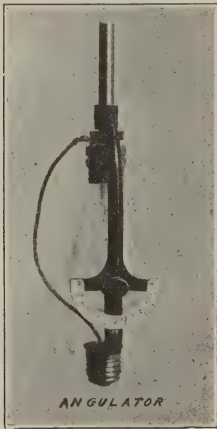

Figs. 1 and 2.—Photometer Attachment.

lamp and considering it in connection with the actual current required to operate it, in preference to measuring the lamp in the arbitrary manner most generally used at present, namely, for its horizontal intensity.

The principal argument against rating

that many feel that they cannot afford to purchase one.

Professor Sharp, of Cornell University, has also devoted time to the solving of the problem, and has prepared a method of calculating the spherical candle power of lamps, having various

forms of carbons, that is sufficiently close for any commercial purpose. Professor Sharp's method consists in determining the mean horizontal candle power in the regular manner and then making one measurement through the tipped end of the lamp, multiplying the mean horizontal by seven-tenths and the tipped end measurement by three-tenths. The sum of the two results will be very close to the real spherical candle power of the lamp.

Most owners of photometers have not, until recently, recognized the great advantage of a lamp delivering a large volume of light through the end opposite the base. The attention of the users of lamps was first called to the value of this light by The Shelby Electric Company. This company is now placing on the market an angulating device—see Fig. 1—which readily fits into the socket of any standard photometer. By the aid of this device the horizontal candle power can be determined and the lamp can then be turned so that the light can be measured at any angle—see Fig. 2.

While the makers of photometers have not encouraged the measurement of lamps in other than the horizontal direction, various papers read before scientific bodies within the last two years show conclusively that the light delivered through the end opposite the base is in fact the most valuable light the lamp emits. It is a remarkable fact that lamps are invariably used for illumination, and illumination is divided into but two classes, namely: general illumination and local illumination. The value of the lamp for general illumination can only be determined by considering the light emitted in all directions, and that by far the greater part of the light that is used for local illumination is delivered through the end of the lamp opposite

the base, or within 45 degrees therefrom. While these statements are indisputable, the practice of rating the lamp by the light delivered horizontally, which light does not enable one to determine the value of the lamp for general illumination and which light enters into the value of local illumination only after having been reflected by walls and surfaces, the reflecting qualities of which vary, is continued, and so long as the users of incandescent lamps are satisfied to buy light on the basis of horizontal delivery, manufacturers will continue to make their lamps so that they will deliver the greatest possible quantity of light in this most unimportant direction.

The angulator has been designed with a view of placing at the disposal of each and every owner of a photometer a method of determining the value of his lamps, regardless of whether the lamp is used for general illumination or for local illumination.

~

A. Bernhard, of Hamburg, Germany, has discovered a valuable property of aluminum, viz., that it is able to sharpen cutlery, the effect produced being most astonishing. Though a metal, aluminum has the structure of a fine stone; it possesses a fine dissolving power and develops during the whetting process an exceedingly fine metal setting substance greasy to the touch, which shows strong adhesion for steel. The blades obtain such a fine, razor-like edge that even the best whetstone cannot compete with the result. Thus, knives which have been carefully sharpened on a whetstone, upon a thousand-fold magnification, still exhibit irregularities and rough spots in the edge, while in the case of knives whetted on aluminum, when magnified to the same extent, the edge appeared as a straight, smooth line.—*Exchange*.



With Our Foreign Consuls



A Russian Alcohol Engine.—In writing of the exposition recently given in Germany under the joint management of the Union of Alcohol Producers and the Association to Promote the Industrial Uses of Alcohol, Consul-General Mason, at Berlin, states that the 50 horse power alcohol engine invented by Director Boris Loutzky, of the Russian marine engineering service, attracted the special attention of the German Emperor, whose enthusiastic interest in all that relates to the use of alcohol for motor purposes on land and sea is well known. The motor was built by the Daimler Motor Company at Marienfelde.

The engine is coupled directly to a generator, but it may be used for marine or any factory purposes for which a motor of that size and horse power is adapted. Its efficiency will be inferred from the tests, which showed its alcohol consumption to vary from 0.45 to 0.5 liter per horse power per hour. At 650 revolutions per minute it developed about 61 horse power and ran with such steadiness that the difference between running light and with full load was only 3 per cent. This regulation is accomplished by means of a centrifugal regulator, which, by creating a vacuum in the cylinder in proportion to the power exerted by the motor, regulates the consumption of fuel. Like many other alcohol motors, this is started and warmed up with gasoline, and a lever changes the supply from gasoline to alcohol as soon as full

speed has been attained. The ignition is by electric spark, and, as a provision against all contingencies, both magneto-electric and accumulator currents are provided, and the former utilized by means of an inductor, the accumulator serving as a reserve in case the galvanic spark should fail. The moment of ignition, which is of great importance in explosion motors, can in this engine be adjusted to occur at the most advantageous part of the stroke, thus securing the maximum effect.

Production of Saltpeter from Air in Germany.—Consul-General Richard Guenther, writing from Frankfort, Germany, says that Professor Muthmann, of the Polytechnical Academy at Munich, in a recent lecture before the Chemists' Association of his city, stated that he had demonstrated that saltpeter can be produced from air by electricity at less than one-fourth its present cost. It has for some time been known to scientists, the professor continued, that nitric acid can be formed by passing high electric currents through moist air between two platinum poles, and suitable apparatus is all that is now needed for the manufacture of nitrates on a large scale.

The Edem Fog Signal.—Consul George W. Roosevelt has sent from Brussels to the Department of State a description of the Edem fog signal, the invention of E. De Meullemeester. Mr.

Roosevelt states that tests made with the fog signal proved in every way successful.

The apparatus consists of (1) a receiver of the waves of sound and (2) an indicator of the source of emission of the sounds. The receiver consists of a series of trumpets arranged in a circle on a mast, with their bells turning to all points of the horizon, the narrow end of each of these trumpets being connected to the indicator by means of a tube. The indicator, close to the hand of the captain or of the officer of the watch, has a tubular ring, from which issue all the acoustic tubes from the receiver, the orifices being fixed round the ring in the order corresponding to the position of the trumpets of the receiver. In this tubular ring is a small opening, to which is attached a hearing tube, by means of which sounds entering the trumpets are heard by the person working the instrument. Each of the acoustic tubes is furnished with a valve or "interrupter" near the orifice, the closing of which intercepts the passage of sound; besides which, the interrupters are supplied with a mechanism enabling the operator to open or close the valves at will. Around the ring of the indicator are marked numbers in an order corresponding with those of the trumpets of the receiver. A movable index needle completes the mechanism. By means of a special arrangement the officer of the watch can perceive the sounds received by the indicator directly and at the same moment as the operator, and so control the exactitude of his work.

When the operator hears a sound coming from some point of the horizon, by means of the mechanism at his hand he closes all the acoustic tubes passing from the receiver to the indicator, except the one in front of the index needle. If then he hears nothing, it signifies that

the sound does not proceed from the direction toward which the bell of the trumpet, corresponding to the open tube, is turned. He then places the index between two tubes (by which means all the tubes are opened again) and notices whether the sound continues, after which he sets the index at the following number, and so on till he discovers the exact direction of the sound. The whole proceeding takes a few seconds.

The experiments which have been made with the signal have proved that one can locate the source of the emission of the sounds in a space of a twelfth of the horizon. By the difference in the intensity of the sound the approach or retreat of a ship can be certainly indicated.

Finances of British Municipal Trading.—F. W. Mahin, United States Consul at Nottingham, states that a comprehensive return of the financial working of the "public utilities" undertakings in British towns and cities has just been given to the public through a Government board. It covers the four years ended March, 1902. The principal undertakings carried on by 299 corporations were:

Markets.....	228
Waterworks.....	193
Cemeteries.....	143
Baths.....	138
Electricity.....	102
Gas Works.....	97
Tramways.....	45
Harbors.....	43

Summarized, the return shows that the total capital provided by these towns and cities, with a gross population of 13,093,870, was \$589,675,348, of which \$490,476,035 was borrowed money. Originally \$569,540,720 was borrowed, but \$79,063,684 has been repaid. The average annual income was \$63,462,620, and the annual working expenses \$40,045,098.

To give a particular case: Up to the date referred to (March 31, 1902) Nottingham had borrowed for the use of its various undertakings—water, gas, electricity, tramways, markets, baths, and cemeteries—a total of \$13,840,604. The gross annual income was \$2,330,000; working expenses averaged \$1,523,000. The net profit on the several undertakings—applied in aid of rates—amounted to a saving of about \$158,000 per year to the city taxpayers during the four years ended March 31, 1902.

Hematite Mining in Spain.—D. R. Birch, United States Consul at Malaga, Spain, reports from there as follows:

A rich vein of oxide of iron ore—valuable chiefly for the manufacture of red paint for structural iron work—has been discovered near the city of Jaen, in the province of that name, about 85 miles from Malaga. Compania Mineralurgica, the firm owning and operating the mine, has established a plant on the outskirts of this city, where the ore is refined and prepared for export. The owners claim that this deposit is the only one of consequence in Spain, a small mine near Santander being its sole rival. The ore is known as hematite, or sesquioxide, and those interested claim that it possesses a durability of color and the other properties necessary for the manufacture of red paint not excelled, if equaled, by the production of any other mines in the world. The ore is shipped both in its crude state and refined, ready for mixing with oil. Levigation is effected by submitting the crude ore to the process of grinding by stone crushers. It is then forced through filters of purified water, and finally dried in kilns. The result is a fine red powder, which, mixed with a trifle more than 10 per cent. of linseed oil, produces paint ready for use. Iron structural work of all

kinds is usually protected by a coating of this paint. Additional interest seems to attach to the industry, in view of the marked decrease—of 31 per cent.—in the production of hematite in the United States in 1901. This fact has encouraged local exporters to renew their efforts to establish in America a firm market for their product, and all signs indicate that they are meeting with success. According to published reports the price in 1901 for the American ore was \$12.87 per short ton. Last year the Malaga product was invoiced here at 50 pesetas (approximately \$6.80 in United States gold) per short ton of crude ore, and at exactly double that price for the levigated or prepared material.

Demand for Steel Castings in Ireland.—Consul W. W. Touvelle writes from Belfast:

From recent investigations that I have made, and from numerous inquiries received from different firms in this city, I am satisfied that a good market is open to American manufacturers who can supply steel castings of high permeability for electrical works. Castings of magnetic steel, for field magnets of electric motors and dynamos, and magnetic steel or sheet-iron stampings, of high permeability and low hysteresis, for armature cores, are mentioned. L. B. Mollan & Co., Alexander street West, Falls Road, electrical and mechanical engineers and contractors, and Millin & Co., Ultonia Works, 59 Victoria street, are desirous that their names may be brought to the attention of steel manufacturers of the United States, as they are large users of the castings described.

For the benefit of possible shippers I will say that two lines of ocean steamers run direct from the United States to Belfast, Ireland—the Lord Line from Baltimore and Newport News, and the Head Line from New Orleans.

Small Plant Switchboards

IN most instances where small isolated electric plants have been installed for lighting one or two buildings, no standard lines have been followed, and, consequently, the switchboard has had to be specially designed for the requirements of each case. No uniformity has prevailed, and the renewal of parts has caused great inconvenience. As a solution of this difficulty the General Electric Company has recently placed upon the market a line

a separate and complete switchboard, and is not intended for combination with other panels. The greatest care has been used to determine the best and most economical form of switches and instruments for this class of service, and, while the usual standard of finish and efficiency have been maintained, the cost has been kept within reasonable limits. These small plant switchboards are manufactured only for use on voltages of from 125 to 250, continuous current, and

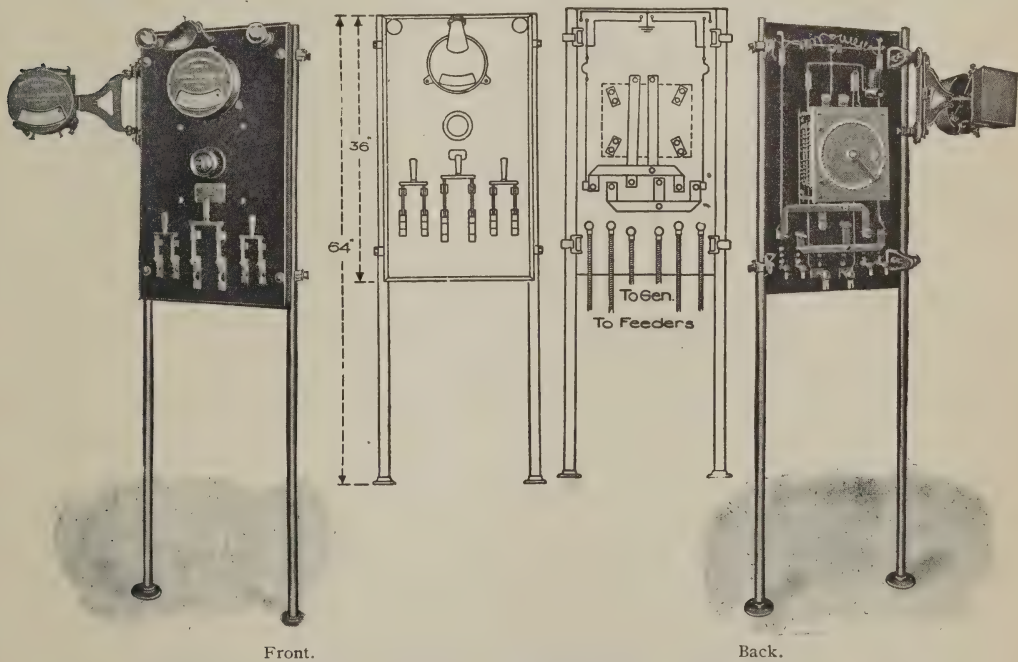

Small Plant Switchboards. Showing Front and Back Views and Wiring Connections.

of standard switchboards for small isolated lighting plants. The design includes a complete series of combination generator and feeder panels for direct-current service. Each of these panels is

only in capacities as specified in the appended list.

These standard switchboards provide for the generator and two feeder circuits. A careful investigation of the

existing conditions in small plants indicates that this arrangement provides for all ordinary classes of service.

The material used in the construction of the switchboards is a fine variety of slate, which is selected with special reference to freedom from metallic or other impurities likely to impair its insulating qualities. The panels are hand finished to a perfectly smooth surface, after which several coats of lacquer are applied,

of two one-inch gas pipes, each 64 inches long, the panels being fastened to the pipe by means of four cast-iron clamps, while the pipes are held in position by two cast-iron flanges, which are bolted to the floor by lag screws. Fastened to the center of each of these pipes is a tie rod, which permits the panel to be supported from the wall, from the machine frame, or to stand in the center of the room.

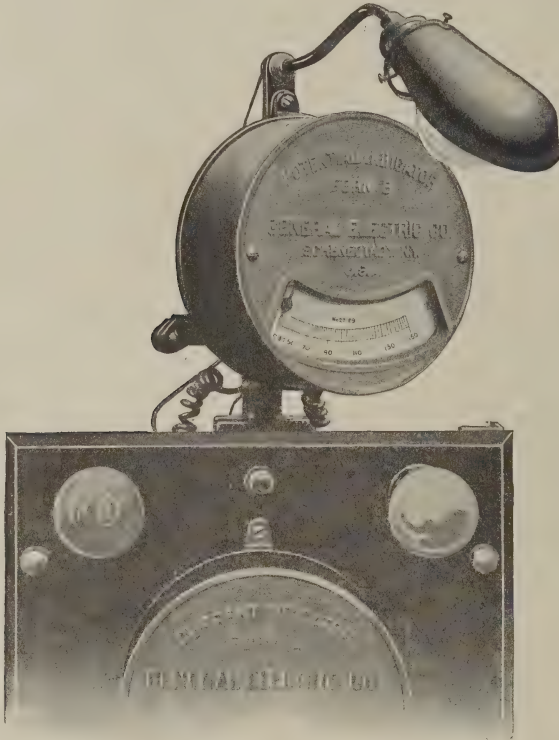

Panel with Potential Indicator Supported on Top Bracket.

thus producing a dull black but extremely smooth surface. The slate is one and one-half inches thick, has square corners and bevel front edges. The dimensions of the slate are 36 by 16 to 20 inches, depending upon the capacity. All exposed metal parts on the front of the switchboard, except the live copper, have dull black finish.

The supports of these panels consist

of two one-inch gas pipes, each 64 inches long, the panels being fastened to the pipe by means of four cast-iron clamps, while the pipes are held in position by two cast-iron flanges, which are bolted to the floor by lag screws. Fastened to the center of each of these pipes is a tie rod, which permits the panel to be supported from the wall, from the machine frame, or to stand in the center of the room.

These tie rods are provided with the necessary clevises, these clevises having a hinged joint, which will allow the flanges at the end to be bolted in a vertical, inclined or horizontal position. The rheostats are not included with the standard switchboards. The panels are, however, supplied with four wrought-iron legs, which are so arranged as to support the standard rheo-

stats used with the machine corresponding to the rating of each standard size of switchboard.

The switches used on all panels of this class are the well-known General Electric form "D" lever switches. They conform to the Underwriters' requirements, and have solid forged clip blocks and studs, and the blades are rigidly fastened to the cross-bars. The blades, clips, clip blocks and studs are of copper, and all the smooth surfaces have ground finish. The handles of the switches are hardwood, with a hard rubber black finish.

element likely to change. The satisfactory character of the scale of this instrument will be appreciated by referring to the full-sized illustration shown herewith. The current indicator is mounted in a cast metal case, having raised letters and finish to correspond with the general finish of the board.

A potential indicator is not provided with these panels, since in some installations, where they will be used, the illuminating lamp of the current indicator may serve sufficiently well as a pilot lamp. A potential indicator of the same type as the current indicator previously

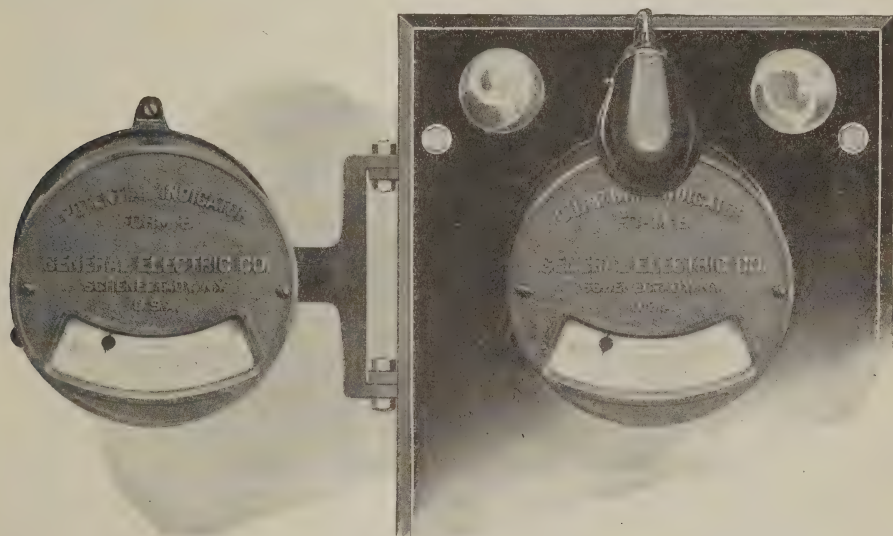

Panel With Potential Indicator Supported on Side Bracket.

Three complete sets of fuses are provided with all switches. Each feeder fuse has approximately 75 per cent. of the capacity of the generator fuse.

On all of these panels the current indicator is permanently connected to the generator circuit. This current indicator is the General Electric Company's well-known round pattern, form "B." This instrument is particularly adapted for long, continuous hard service. Its few parts are strongly constructed, and, having no spring, it is free from any

described, and provided with either a pivoted bracket supported at the top of the panel or with a swinging bracket supported at the side of the panel, is, however, carried in stock as a standard extra part, and all panels are drilled for mounting these brackets. The manufacturers recommend that all panels be ordered with this item to facilitate good voltage regulation.

The standard two-lamp ground detector is used on these panels; that is, one lamp is connected from each bus-bar

to the ground, the voltage of the lamp always being the same as the voltage of the panel.

A 16-candle-power lamp, supported on a curved lamp bracket with a half-round metal shade, is included with each of these panels.

When a panel is installed, and later it is desired to have a pivoted potential indicator bracket mounted on top of the board, the lamp bracket should be removed from the panel. This will allow for mounting of the pivoted bracket without any additional drilling of the panel. The lamp bracket may then be mounted on the pivoted bracket, which is so designed as to receive it.

The potential indicator, mounted on a swinging bracket, is not supplied with a lamp bracket, as the lamp on the panel will illuminate the potential indicator properly if the swinging bracket is swung at a slight angle.

The electrical connections of the various parts of the panel are shown in the accompanying diagram. All connections are made of bar copper, and terminals are provided for connections to the system.

Below is a list of standard switchboards, giving the capacity, voltage, etc. :

Kilowatt Capacity.		Capacity of Current Indicator.	1 DPST Gen. Sw. Amp. Cap.	2 DPST Feeder Sw. Amp. Cap.	Dims. of Panel.	Approx. Weight Boxed.	Cat. No.
125 Volts.	250 Volts.						
.75	.75-1.75	10	50	25	36 x 16	500	57918
1.5	2.5	25	50	25	36 x 16	500	57919
1.75-2.5	4.5	25	50	25	36 x 16	500	57920
4.5	6.5-9	50	50	25	36 x 16	500	57921
6.5-7.5	12.5-13.5	75	100	50	36 x 20	500	57922
9	17-20	100	100	50	36 x 20	500	57923
12.5-13.5	25-30	150	200	100	36 x 20	500	57924
17-20	40	200	200	100	36 x 20	500	57925

These switchboards are manufactured by the General Electric Company, of Schenectady, N. Y.

Steam-Driven Pelton Wheel.

Mr. A. E. Johnson, Jr., has applied a six-inch Pelton wheel to driving a rapidly revolving blower. A three-quarter inch steam pipe is used with a nozzle five thirty-seconds of an inch in diameter. The blower was driven at 4,500 revolutions per minute, but with the throttle of the globe valve, by which the steam supply was regulated, fully open, 10,000 revolutions per minute were obtained. Mr. Johnson states that he believes the steam consumption was less than with a reciprocating engine generating the same power, and makes several suggestions as to the further application of such an installation. However, as it is a well known fact in mechanics that, using an impact wheel, the peripheral speed must nearly approach that of the impinging jet, it would seem improbable that an economical use of steam could be made in this manner, as the velocity of steam under pressure is considerably in excess of that which could be obtained by a wheel without its ultimate disintegration.—*Engineering News.*

The "Greatest Show on Earth," as Barnum & Bailey's circus is more commonly known, recently arranged for the lighting of its huge canvas pavilions by means of the Nernst lamps. Seventy lamps will be used, ranging in size from the one-glower to the six-glower type. Nernst lamps will also be used exclusively for display advertising. To furnish current for the lamps special generators have been purchased.

Mr. W. E. Andrews, until recently associate editor of the "Street Railway Journal," is in charge of the New York office, 25 Broad street, opened by E. P. Roberts & Co., consulting engineers, of Cleveland, Ohio.





Three-Phase Locomotive on the Gross-Lichterfeld Electric Line (See Page 437).

THE ELECTRICAL AGE

NEW YORK

VOL. XXX

JUNE, 1903

No. 6

The Heyland Asynchronous Motor

An Induction Motor Operating at Unity Power-Factor

By A. S. McALLISTER

IN analyzing the performance of an induction motor there are discovered two predominating characteristics which, on the one hand, render the understanding difficult and, on the other hand, cause its phenomena to be most easily analyzed. These characteristics are found in its simultaneous similarity to both a static transformer and a shunt wound direct-current motor. With regard to its mechanical output, the induction motor is essentially the equivalent of the shunt motor; its characteristics for speed, torque, efficiency, etc., being governed by laws which apply equally as well to the latter as to the former machine, while electrical characteristics for input watts, primary current, power-factor, etc., are similar in all respects to those of a static transformer. The prin-

cipal difficulty which one encounters in attempting to grasp the significance of the various changes in the performance characteristics of an induction motor is due to the neglect of these facts.

The induction motor considered as a transformer is one with large exciting current and considerable magnetic leakage. The value of the exciting current of any transformer is determined by the necessary magnetic lines to produce, by their rate of change, an e.m.f. in the primary windings equal to the impressed line e.m.f., and by the reluctance of the path which these lines must take. In the familiar static transformer the path of the lines lies wholly within material of high permeability, while the magnetic lines in an induction motor are compelled to traverse a path of high reluctance—

that is, a path through air, equal in length to twice the amount allowed for mechanical clearance between rotor and stator.

To prevent magnetic leakage, the primary and secondary windings of a static transformer are interspaced as closely as the requisite insulation for the circuit e.m.f. will permit. The mechanical and electrical requirements of an induction motor, however, are such that not only must the primary and secondary windings be separated by an air gap, but the conductors comprising the individual coils must be almost wholly surrounded by iron, forming a local path of high permeability, so that the reactance of the windings of an induction motor is very considerably greater than that of a static transformer.

It will be appreciated from the above discussed facts that, in comparison with that of a static transformer, the power factor of an induction motor must at all times be quite low. Its mechanical performance, however, is the equal of that of any motor of either the alternating or direct-current type. In fact, for service where practically constant speed is required the present-day induction motor is above criticism in all respects except as concerns its power-factor.

The various details of construction which may be employed to improve the operating power-factor of the motor fall into two general classes: those which tend to the reduction of the reluctance of the path of the core flux, and those which decrease the reactance of the windings. The former of these methods usually involves the use of a diminished air-gap. Modern induction motors are constructed with air-gaps as small as allowed by the mechanical requirements for the rotating member, so that the limit to the decrease of the air-gap is already reached and further improvements along

this line cannot be hoped for. The reactance of each winding is due to the interlinkage, with the conductors, of local flux which surrounds that winding without encircling the other. The local flux may be decreased by increasing the reluctance of the path which the lines must take—that is, by using open rather than closed slots and operating the lugs at high magnetic density, while the interlinkage of the flux and conductors may be decreased by separating the windings into many rather than few slots, since, when a number of conductors are concentrated in a single slot, the flux due to the current in each conductor surrounds the other conductors also, the result being that, for constant reluctance of the surrounding magnetic material, the reactance per slot varies as the square of the conductors therein.

The current which flows in the primary windings of an induction motor may be resolved into two components: the power, and the wattless. An increased power-factor necessitates a relative reduction in the wattless component. The Heyland induction motor is one which employs a mechanical method for supplying, to the secondary windings, current in just such value and phase position with relation to the current in the primary as to produce the same effect as would have been caused by the wattless component of the primary current, which component, therefore, ceases to exist and the power-factor, consequently, increases to unity. The method of obtaining this most desirable result consists in applying to the secondary windings a commutator to which current from the source of supply for the primary is led by way of properly disposed brushes. The commutator necessary for the operation of the motor is small in size, and, on account of the fact that adjacent segments are connected together by non-inductive re-

sistance external to the windings, there is no possibility of sparking at the brushes, and its performance is quite similar to that of slip rings.

Fig. 1 represents diagrammatically a direct-current armature complete with commutator, to be used as the secondary of an induction motor. Since no current whatever will flow in the conductors of a direct current armature when on open circuit, the armature alone will possess no tendency to be drawn into rotation by the revolving magnetism of the primary. In order that the armature winding may

be a motive force for field excitation, in order that no wattless current need flow in the primary windings.

If there flow in the secondary conductors current of proper value and phase position relative to the field, the core magnetism will demand magneto-motive force from no other source, and the exciting current will cease to exist in the primary coils. This statement is general and applies to any alternating current transformer, it being a fact well known that leading current in the secondary coils of a static transformer may be so adjusted in value as to nullify the primary exciting current.

It remains, now, to investigate the method by which the secondary current is given the proper value and phase position. Imagine the rotor at rest and normal e.m.f. impressed upon the primary circuit. Neglect for the moment the existence of the resistance shunted between the segments. Three-phase current introduced into the secondary by way of the three brushes may be given any value by corresponding adjustment of the e.m.f. impressed upon the secondary terminals, and it may be caused to take any phase position relative to the revolving field due to the primary current, by shifting the three brushes simultaneously in the same direction. Thus, with stationary rotor, the wattless current in the primary windings may be varied in value at will and may even be caused to become leading.

serve as the secondary of the induction motor, it is necessary that points on the armature possessing difference of potential be joined together. The resistance, shown in Fig. 1 as being connected between adjacent segments, serves to complete the secondary circuit, and with the brushes removed from the commutator the motor thus equipped will operate in all respects similarly to one with a pure "squirrel-cage" secondary winding. The three brushes shown in the figure are for the purpose of allowing the introduction of three-phase current into the secondary for supplying sufficient magneto-

When the rotor travels at any speed, any certain value of current in the secondary windings produces the same effect as with stationary rotor, since the commutator causes the current at each instant to traverse conductors occupying the same position in space as before, and the effect upon the core magnetism is not altered by the motion of the rotor. The motion of the rotor in the direction

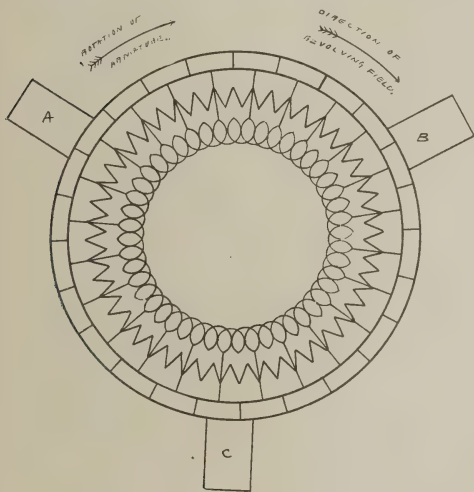

FIG. 1. Direct-Current Armature of Heyland Motor for three-phase secondary excitation, showing segment connecting resistances.

of the revolving field, however, has the very desirable effect of decreasing the e.m.f., which must be impressed upon the secondary to cause to flow a given current through the windings. The latter effect is due to the decrease of the reactance of the secondary windings, as the secondary frequency decreases. The frequency of the current in the secondary is equal to the product of the primary frequency and the percentage slip of the rotor from synchronism. For constant coefficient of self-induction, therefore, the secondary reactance varies directly with the slip and is of zero value at synchronous speed. This means that at exact synchronism the e.m.f. at the commutator brushes to produce a given secondary current must be of just such value as to cause that current to flow through the secondary resistance (without reactance), and that the secondary current will be in phase with the e.m.f. When it is remembered that the resistance of the conductors is in any case quite small, it will be appreciated that the e.m.f. for secondary excitation need be but a small per cent. of the primary e.m.f. and that the power thus expended is quite insignificant.

It is well at this point to investigate the effect of the presence of the segment connecting resistance of the secondary winding. An inspection of Fig. 1 will reveal the fact that current which flows from one brush to another has two possible paths to travel: through the direct-current armature windings or through the connecting resistance. For sake of clearness, this condition of connections is separately represented in Fig. 2, which shows an inductive and a non-inductive resistance in parallel supplied with current from a source of constant alternating e.m.f. Evidently the current through the non-inductive branch will be constant in value, while that through the other

branch will change inversely with the impedance of the inductive circuit. The impedance is equal to

$$Z = (R_z^2 + L_z^2 W^2)^{1/2}$$

of which R and L are practically constant. W, however, varies directly with the slip, so that at synchronism the reac-

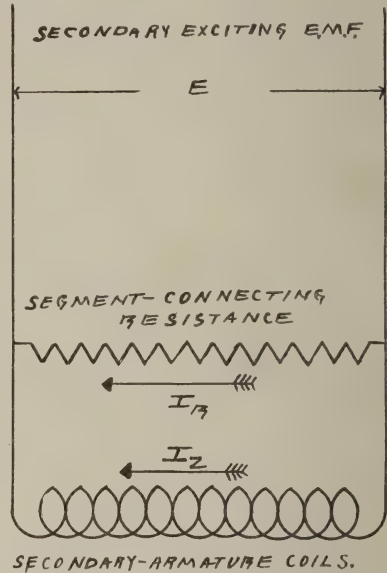

FIG. 2. Relative Distribution of Exciting Current in segment connecting resistance and Armature Coils.

$$I_R = \frac{E}{R}$$

$$I_Z = \frac{E}{Z}$$

$$I_Z = \frac{E}{\sqrt{R_z^2 + L_z^2 W^2}}$$

$$I_Z = \frac{E}{R_z} \text{ when } W = 0$$

tive component, LW, of the impedance disappears and the current which flows through the inductive branch will be

$$I_Z = \frac{E}{R_z}$$

as stated previously. When the connecting resistance is present, the secondary e.m.f. for excitation is the same as before, but the current is increased somewhat. The relative increase of the secondary current depends upon the ratio

of the resistance of the connections to that of the armature windings. For the most economical results for the excitation alone this ratio should be large, while for best mechanical performance of the machine the resistance should be as small as possible. No difficulty is experienced in so proportioning the resistances that the shunt excitation loss remains quite small, while the performance is not materially affected by the increased series resistance.

The statement that the secondary frequency varies directly with the slip is true for any pure "squirrel-cage" or form-wound secondary, and, in any case, the reactive e.m.f. varies with the frequency when the coefficient of self-induction is constant. In the direct-current armature used as a secondary for a Heyland motor, neither of these two conditions is realized, and, consequently, the deductions obtained from assuming these conditions must be somewhat modified in order to faithfully represent the true performance of the motor. With three-phase secondary excitation the current in any individual conductor is never truly unidirectional and unvarying in value, so that the reactive e.m.f. of the windings does not disappear, even at synchronism, and the secondary current is never without a wattless component. However, as a little study of the change in the value of the current in the individual conductors will show, and as practical tests have demonstrated, the reactive e.m.f. is so much reduced below the value for the primary that a very slight excess of current in the secondary causes the primary wattless current to become leading and of a value to compensate fully for the lagging current in the primary of the lowering transformers, and the

power-factor of the equipment as a whole is thereby rendered equal to unity.

A shifting of the brushes upon the commutator produces the same effect as a relative change in phase of the secondary exciting current. With the secondary current adjusted for even compensation for the brushes at the neutral position the wattless current of the primary may be given double value by a movement of the brushes 180 electrical degrees, and any value between this and zero may be obtained by a corresponding setting of the brushes. By adjusting the secondary current for a certain amount of over-compensation and setting of the brushes the requisite number of degrees in the proper direction from the neutral point to give even compensation at no-load, the induction motor may be operated throughout its working range at practically unity power-factor at all times.

In cases where it is desirable to insert additional secondary resistance for the purpose of increasing the starting torque, etc., a form of three-phase secondary winding with collector rings from the neutral points has been found to render good service. An additional advantage possessed by the three-phase over the direct-current armature winding is found in the fact that by dividing the windings of each phase into two parts and placing the two parts per phase in the same slots the reactive e.m.f. of the winding is much reduced. This is due to the fact that when one conductor of each slot carries its minimum current the other carries its maximum, so that the current per slot is quite uniform in value, and the local flux surrounding the slot, therefore, undergoes but slight change in value.

Electric Power for Lumber Mills

By GEORGE E. WALSH

OUR lumbering interests have increased so rapidly in the past decade that the most available forests have been cut down, and each year the mills have to penetrate deeper in the forests to secure their supply of raw material. The question of securing the lumber on the mountain sides or in the woods far back from any river has puzzled lumbermen for years; but a number of modern devices have enabled the mills to secure the logs at a minimum of cost, and we may find to-day electric power hauling logs and trees across chasms or down steep mountain sides in the most unique manner.

In California, for instance, where the valuable forests of sugar pine clothe the sides of the Sierra Nevadas to a great altitude, the electrical engineer has solved the problem of reaching the trees by stretching immense cables from one altitude to another, and transporting the trees across chasms a thousand feet deep; finally landing them at the mill several miles away. The electric power is generated at the mill, which is fed with the waste wood that is so plentiful all around, and the transmission cable is carried across the chasms on the heavy transportation cables. This novel cable tramway is capable of carrying a hundred tons of lumber. One of the gorges is spanned by two cables three thousand feet long and capable of sustaining a total weight of 125 tons. Across this

tramway a steel cage is carried by deeply grooved wheels. The steel framework for the lumber connects on a level with the rails of the lumber cars on the opposite end, and the work of transporting from one to the other is simple. In this way the timber at an altitude of several thousand feet on the mountain sides can be reached as easily as the trees along the bases of the mountains. By simply extending the suspended tramway to other parts of the mountains the lumbermen can reach the forests at any desired point. The improvement has practically solved some of the most important questions of lumbering in the mountain regions.

In Maine and the Adirondacks, where the problems of lumbering are a little different, electricity has also proved a boon. The trees there are located so far back from the rivers that their value is of uncertain quantity. It has been a constant increase in the cost of skidding them down to the rivers each year. Oxen and horses have been employed to haul the logs over the snow, but this method has been slow and laborious. In both the Adirondack and Maine lumbering regions electric tramways have recently been adopted. These are temporary rails laid through the woods. A small motor engine runs over the track and hauls a train loaded with lumber down to the saw mill or river front. One engine with good switching facilities at

the mill or river terminal can in this way do the work of fifty teams of horses or oxen. The cost of laying such a track is not great, for the logs suitable for temporary cross-ties are plentiful on all sides, and it is merely a question of trimming and laying them down on a firm foundation. When a track is once laid, it continues to work its way into the forest as the trees are cut down on all sides. The hauling to the track is done by teams, and the trolley thus cuts a swathe through the woods from half a mile to two miles wide on either side.

For the past two winters experiments have been made with a number of devices for hauling the logs over the snow by means of the trolley. A smooth roadway on the surface of the snow has been leveled on one side of the trolley track, and sleds loaded with logs have been hauled by the engine. The chief difficulty about this is that the snow drifts over the tracks, and it is hard to keep them open for operation. Efforts have been made to invent some sort of a heavy winter electric truck that could trundle over the snow in winter and haul a train load of sleds behind it. Quite a number of different inventions of this character have been tried, and some of them promise success. With an independent engine to travel through the woods in winter, having power enough to haul ten to twenty loaded sleds behind it, a good many of the present logging problems would be immediately solved.

Another method of facilitating lumbering in the almost inaccessible woods is to construct a portable saw mill, which moves from one part of the woods to another, eating up the trees as it proceeds, and leaving behind an open trail for second growth timber to sprout up. These portable saw mills are nearly all operated by steam and electricity. They are mounted on heavy wheels, and

can be propelled by their own power through ordinary woods where a roadway has been cleared ahead. They change their position from time to time, operating in one place usually a whole season, and then moving on a few miles deeper in the woods for the next season's work.

All parts of the mill are portable except the wooden structure which is built around to protect the machinery and the finished lumber. The cost of constructing a new building for the mills is cheap. The raw material is scattered around in abundance, and the only cost is that of labor and power. This latter is generated chiefly by burning the waste wood from the trees. No other fuel is used. A small electric motor is always a part of the portable mill's equipment. This is used for lighting the mill and for operating some of the small planing machines. A good many of the modern mills saw and finish off the lumber right in the heart of the woods, and then ship it by teams, cars, or by river boats to its destination in much decreased bulk. The saving obtained in this way forms quite an important factor in mill operation. The less waste to transport the less will be the expenditures for operation of the plant.

The cost of generating electric power to drive different parts of a lumber mill where wood is used as a fuel is naturally very small, but the firing is clumsy and expensive, as it requires almost the continuous work of one or two men to feed the fire with the light, inflammable wood. In hard wood forests this is less difficult, as the fuel lasts longer and produces more sustained heat. Special types of furnaces and boilers have been constructed for the lumber mills so that wood fuel can be used easily. Logs and sticks five and six feet in length can be used in these furnaces. They are

built with special devices for feeding, so that one man can shove heavy logs into the fire without the assistance of another.

With the increased adaptation of electricity to these lumber mills there has developed a tendency to locate furniture factories and similar plants right in the heart of the forests. These plants are equipped with all the machinery necessary to finish the articles for immediate use. Electric power is carried to half a dozen different planers, borers, presses and cutters, which are employed in manufacturing different parts of furniture, buckets, barrels and boxes. The veneering machines, for making fruit baskets, are generally operated by electric power, which is either produced by water or by wood fuel fed under a steam boiler. The modern furniture or box and basket plant in the woods is composed of many different parts, which must of necessity be scattered over quite an area; electric power is the only convenient one that can be used to operate all of them together or separately.

The question of making successful and economical electric tree cutters has been one that has engaged the attention of engineers in this country and Europe. Years ago an electric tree cutter was used with some success in the forests of Germany. This was said to be operated somewhat after the manner of a modern electric coal cutter. There was an endless chain, with a series of sharp knives attached to it, and when the machine was in operation the chain would force these knives against the trunk of the tree until it was cut down. Similar attempts have been made in this country, but this form of tree cutter is useful only in forests where the trees are of immense girth. The time and trouble required to move and adjust the cutter to new trees rep-

resents too great a loss to prove economical except where the trees are of ample proportions. In the California forests of redwood trees such chain cutters have been operated, and they prove economical; but the world has few such trees in existence as these wonderful survivals of past ages. To make electric tree cutting profitable in the ordinary woods, some sort of simple, portable, and quickly-adjustable machine must first be invented.

A series of experiments was recently carried out at the Altenburg colliery, near Saarbrucken, Germany, with lime, tar and carbolineum to determine the respective value thereof as preservatives of mine timber against rot. Lime was found to be of the least value, while coal tar, although insuring perfect preservation of the surface of the timber, failed to protect the interior, which in every instance was found to be seriously attacked by rot. Carbolineum, however, gave excellent results, provided the timber coated had been previously barked and well dried.—*Exchange*.

Alloys are usually more fusible than the least fusible metal contained, and they are almost always heavier or denser than the average of their uncombined constituents. A remarkable exception to both rules is an alloy of 18.87 per cent. of aluminum and 81.13 per cent. of antimony. Both metals melt at about 650 degrees centigrade, while the alloy requires a heat of 1,080 degrees centigrade; and the specific gravity of the latter is only 4,218—instead of 5,225, which it would be if there were no change of volume. In other words, 7.07 cubic inches of aluminum and 12.07 of antimony produce 23.71 cubic inches of alloy.—*Exchange*.

The Curtis Steam Turbine

By W. L. R. EMMET

THE development which this paper describes is based upon the original theories and inventions of Mr. C. G. Curtis, of New York, whose ideas were first made the subject of patent application about 1895. Since that time these inventions have been the subject of experimental investigation at Schenectady under the direction of Mr. Curtis and of the General Electric Company's engineers; the object of these experiments being to establish data and laws which would form a basis for the correct design of commercial apparatus. The difficulties of such an investigation are very great. All new facts must be established by the test of different machines or parts which are difficult and expensive to produce. About two years ago the results of these experiments gave us data which showed great commercial possibilities, and since that time the work has gone on on a large scale in the production of commercial machines. The contracts for these machines now aggregate 230,000 horse power in turbine-driven electric generating units, the largest size so far built being 7,500 horse power. Thus a great industry has been brought into existence in a very short time, and since the work has all been done in one place and by a few persons, very little information concerning it has reached the public. This paper is the first printed matter which has appeared on the subject.

The reason for this immense demand and production without publicity and in so short a time, is that the improvements effected are radical in economy, simplicity and efficiency of action.

All improvements in prime movers are of great importance to the engineering world. The steam turbine is destined to effect the first really great improvement since the days of Watt, and the forms of Curtis turbine here described make the first great stride in advance of other steam engines.

Every efficient steam engine must provide means by which a fair proportion of the expansive force of steam can be converted into useful work. In the engines of James Watt and his successors this result is accomplished in various degrees by the application of pressure from the steam to moving pistons. In steam turbines the expansive force imparts motion to the steam itself, and this motion is given up to a revolving part by impacts of the moving steam upon it.

The idea of the steam turbine is quite simple, and is similar to that of the water turbine or impulse wheel. The practical difficulty which has heretofore prevented the development of good steam turbines lies in the very high velocity which steam can impart to itself in expansion, and the difficulty in efficiently transferring this motion to wheels at speeds practicable for construction or practical use. Steam expanding from

150 pounds gauge pressure per square inch into the atmosphere, is capable of imparting to itself a speed of 2,950 feet per second, and if it is expanded from 150 pounds gauge pressure into a 28-inch vacuum it can attain a velocity of 4,010 feet per second. The spouting velocity of water discharged from a nozzle with 100 feet head is 80 feet per second. These figures illustrate the very radical difference of condition between water turbines and steam turbines. In both water and steam turbines the theoretical condition of maximum economy exists when the jet of fluid moves with a velocity equal to about twice that of the vane against which it acts. In water wheels this relation is easily established under all conditions, while with steam the total power produces a velocity so high that the materials available for simple wheels and vanes are not capable of sustaining a proper speed relation to it under practicable conditions.

Before the appearance of the Curtis turbine two practical methods of accomplishing fair economy had been devised, namely, the turbines of Carl De Laval, of Sweden, and of Hon. Charles Algeron Parsons, of England, both of which were brought out more than fifteen years ago.

In the De Laval turbine the total power of the steam is devoted to the production of velocity in an expanding nozzle, which produces velocity very efficiently. The jet so produced is delivered against a set of vanes on a single wheel which, by an ingenious construction and method of suspension, is adapted to operation at a very high peripheral velocity. The very high rotative speed which this construction entails is made available for dynamo driving by very perfectly made spiral-cut gears which effect a ten-to-one speed reduction. The peripheral velocity of the wheel in the largest De Laval turbines is about 1,200

feet per second, while the velocity which energy can impart to steam is over 4,000 feet per second. Thus the wheel falls far short of the theoretically economical speed.

In the Parsons turbine the steam is carried in an axial direction through the space provided between a succession of internal revolving cylinders and external stationary cylinders which enclose them. Both the internal and external cylindrical surfaces are covered by many successive circles of vanes so arranged that the steam has to pass alternately through rows of moving and stationary vanes. In passing through this turbine the steam never acquires a speed which approaches the velocity which it attains in the De Laval nozzle; but instead, moves along alternately, acquiring velocity by expansion, and partially giving it up by impact with the moving vanes.

Both of these turbines have attained some success, but neither, as thus far developed, affords sufficient advantage over the steam engine to cause any very rapid or radical change in engineering conditions.

The important disadvantages of the De Laval type are, that it is limited by the imperfections of high speed gearing, that its efficiency is not particularly high, and that the design is not conveniently applicable to large sizes. The Parsons type is principally limited by the multiplicity and weight of its parts and the high cost of construction.

The Curtis turbine retains some of the features of its predecessors, but introduces new ideas which make possible a much lower speed, less weight, fewer and simpler parts, higher economy, less cost, and other important advantages.

The general arrangement of a turbine generating unit of this type is shown by the drawings which accompany this paper. Its functions may be briefly de-

Comparison of 200 K. W., 9,000 R. P. M. De Laval Turbine, 500 K. W., 1,800 R. P. M. Curtis Turbine and 375 K. W., 3,600 R. P. M. Parsons Turbine.

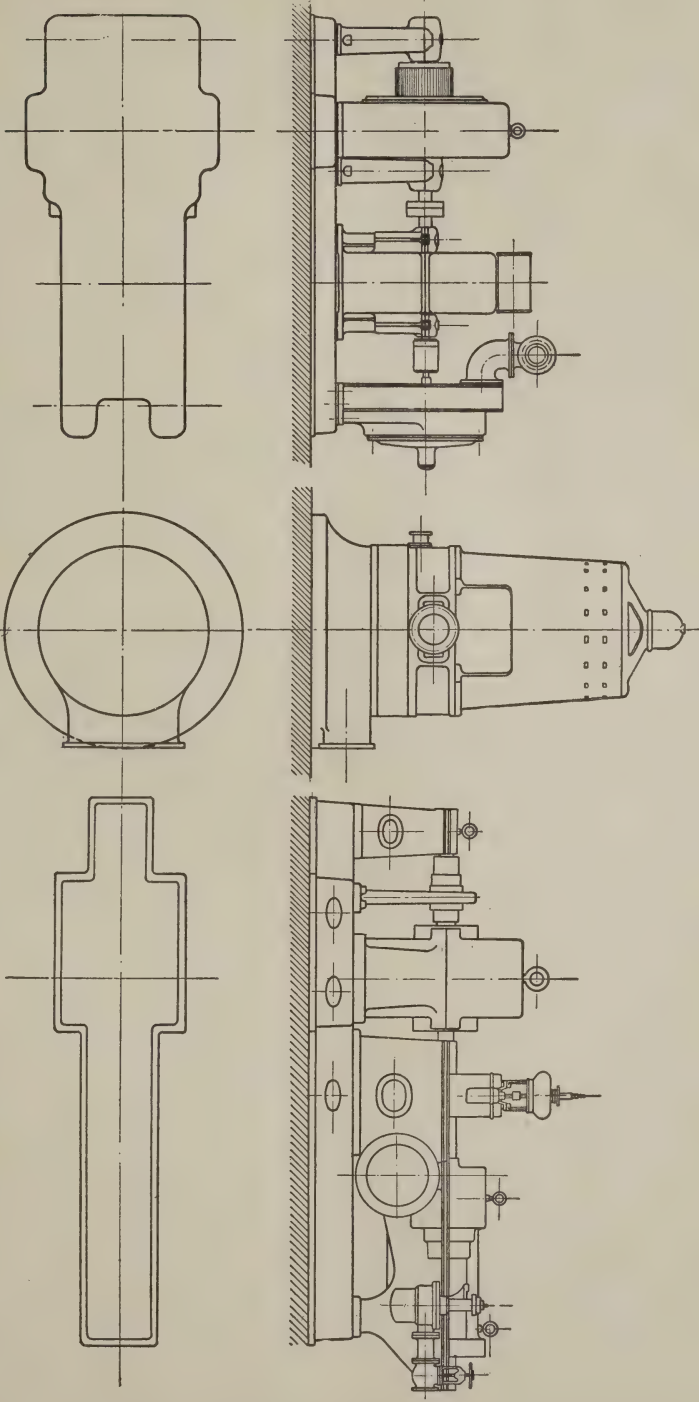

scribed as follows, and are illustrated by the accompanying cut:

Velocity is imparted to the steam in an expanding nozzle so designed as to efficiently convert nearly all the expansive force, between the pressure units used, into velocity in the steam itself. After leaving the nozzle the steam passes

this means a high steam velocity is made to efficiently impart motion to a comparatively slowly moving element. The nozzle is generally made up of many sections adjacent to each other, so that the steam passes to the wheels in a broad belt when all nozzle sections are in flow.

This process of expansion in nozzle

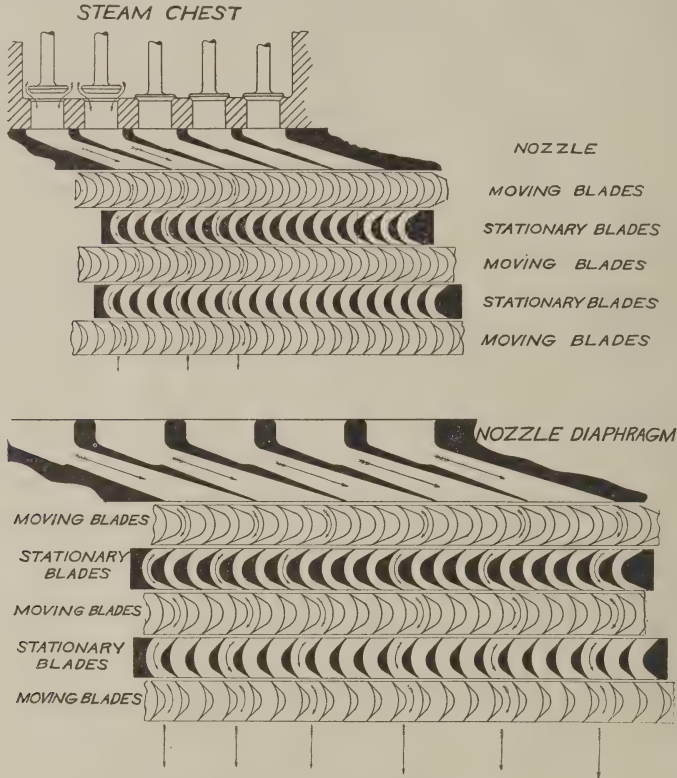

Diagram of Nozzles and Buckets.

successively through two or more lines of vanes on the moving element, which are placed alternately with reversed vanes on the stationary element. In passing successively through these moving and stationary elements the velocity acquired in the nozzle is fractionally abstracted and largely given up to the moving element. Thus the steam is first thrown against the first set of vanes of the moving element, and then rebounds alternately from moving to stationary vanes until it is brought nearly to rest. By

and subsequent abstraction of velocity by successive impacts with wheel vanes is generally repeated two or more times, the devices for each repetition being generally designated as a stage. There may be various numbers of stages and various numbers of lines of moving vanes in each stage. The number of stages and the number of lines of vanes in a stage are governed by the degree of expansion, the peripheral velocity which is desirable or practicable, and by various conditions of mechanical expediency.

Generally speaking, lower peripheral speeds entail more stages, more lines of vanes per stage, or both. Our general practice is to so divide up the steam

thus in part regained. Much water of expansion, which might occasion loss by re-evaporation, is drained out of each stage into that which succeeds it.

The governing is effected by successive closing of nozzles and consequent narrowing of the active steam belt. The cut shows part of the nozzle open and part closed, the arrows showing space filled by live steam. In the process of governing, the nozzles of the later stages may or may not be opened and closed so as to maintain an adjustment proportional to that of the first stage, which is always the primary source of governing. Some improvement of light-load economy may be effected by maintaining a relative adjustment of all nozzles; but in many cases the practical difference in economy is not great, and automatic adjustment of nozzle opening in later stages is dispensed with in the interest of simplicity. In some machines an approximate adjustment is maintained by valves in later stages, which open additional nozzles in response to increases of pressure behind them. These are used as much for limiting the pressures in stage chambers as for maintaining light-load economy.

The principle of the Curtis steam turbine is susceptible of application to a variety of purposes. Within the scope of this paper I intend to give only a general idea concerning existing designs for its application to electric generators. Its development, even for this purpose, is very recent, and will doubtless be subject to important future improvements. In its present state, however, it embodies many important advantages, as has already been stated. The most important of these advantages is the high steam economy which it affords under average conditions of service. This economy is shown by the accompanying curves, which are derived from actual tests of the first commercial machine of this type which was completed. This machine

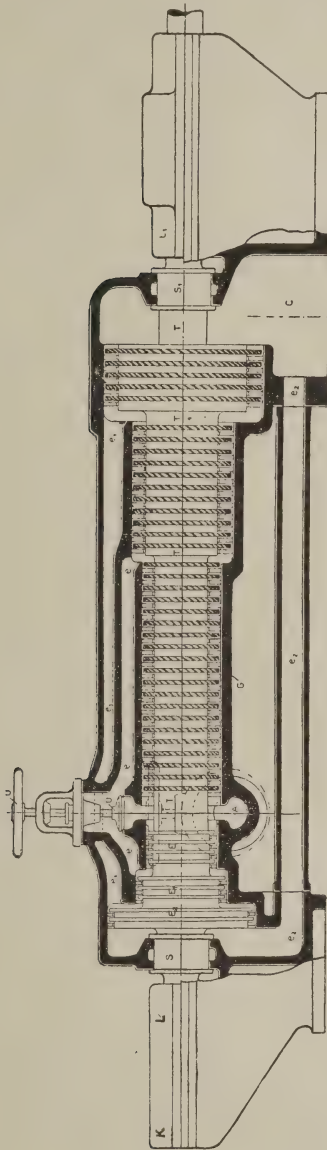

Cross-Section of Parsons Turbine Without Generator.

expansions that all stages handle about equal parts of the total power of the steam.

The losses and leakages of the earlier stages take the form of more heat or more steam for the later stages, and are

drives a dynamo of 600 kilowatts capacity. The curves give its performance at a speed of 1,500 revolutions per minute, which is a safe and practical speed for commercial operation, and which corresponds to a peripheral velocity of about 420 feet per second. The results, with superheat, given in these curves are not derived actually from tests of this turbine, but are plotted from data obtained on smaller turbines. They correspond to the results obtained on turbines of other types, and are undoubtedly reliable.

the use of such high temperatures would with ordinary construction be prohibitive.

The results shown by these curves are better than any heretofore produced by steam turbines of any make or size, and are very much better than those obtainable from the types of steam engines generally applied to the production of electricity.

It should be noted that these curves show a very high efficiency at light loads, as compared with results obtainable from steam engines, and that the efficiency does

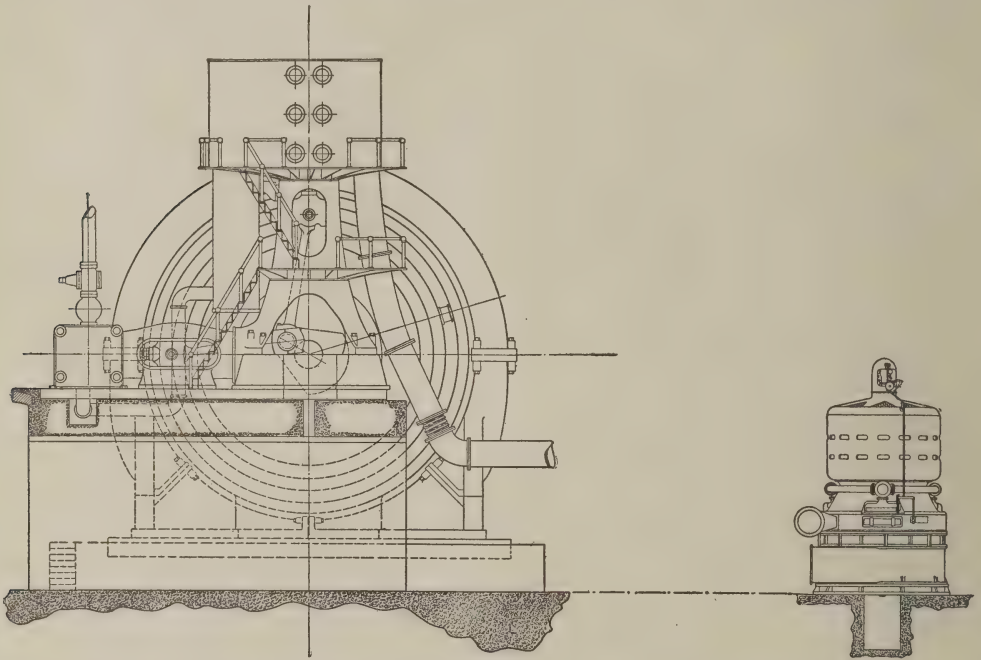

Comparative Sizes of 5,000 K.W., 75 R.P.M. Corliss Engine and 5,000 K.W., 500 R.P.M. Curtis Turbine.

Curve 1 shows the steam consumption of this machine in pounds per kilowatt-hour output at various loads and under the conditions stated, the lower curve giving the steam consumption at various loads with 150 degrees superheat.

Curve 2 shows the results which could be obtained from this turbine if it were operated with high pressure and a high degree of superheat, these conditions of operation being perfectly practical with the machine, while with steam engines

not fall off at overload as it must necessarily do with all engines which operate economically under normal full-load conditions. This light-load and overload economy is an important feature of the Curtis turbine, and arises from the fact that the functioning of its working parts is virtually the same under all conditions of load.

Curves 3, 4 and 5 show the effect upon steam consumption of changes in the steam pressure, the degrees of superheat

and in the vacuum. It will be observed that the superheat and vacuum curves are straight lines, so inclined as to indicate

is adapted to use effectively the highest possible degrees of expansion, while in the steam engine it is practically im-

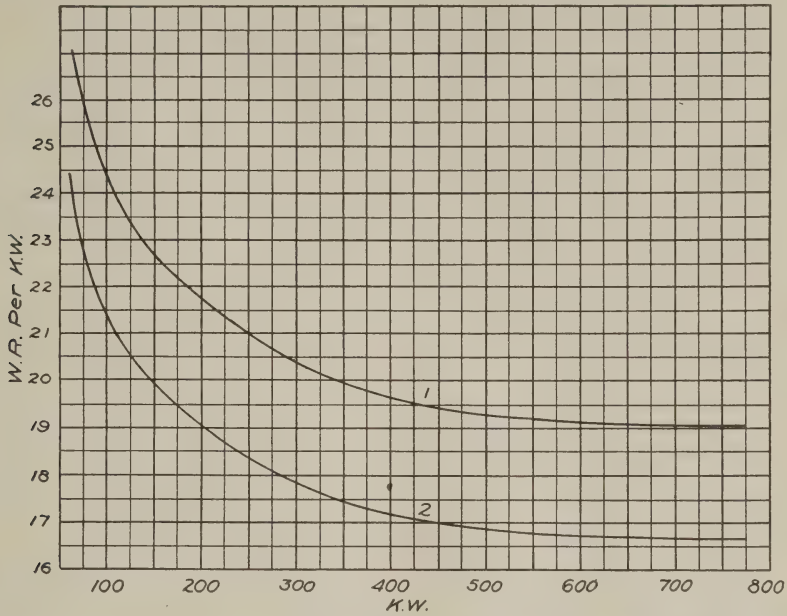

CURVE 1.
Comparative Curve Showing Water Consumption, in pounds per K.W., of 600 K.W. Curtis Steam Turbine, when operating at 1,500 R.P.M., Under 140 lbs. Pressure and a Vacuum of 28.5". 1. Without Superheat. 2. At 150° Fahr. Superheat.

a great advantage by the use of all degrees of superheat, and also an immense advantage in the use of very high vacu-

possible to provide for high degrees of expansion. As the exhaust pressure approaches a perfect vacuum, the volume

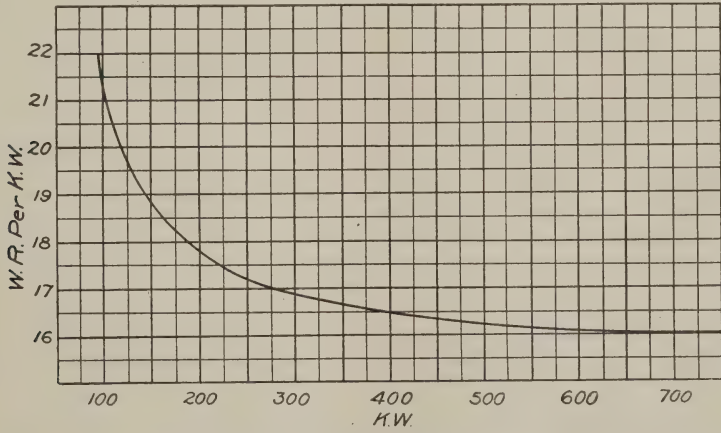

CURVE 2.
Curve Showing Water Consumption, in pounds per K.W., of 600 K.W. Curtis Steam Turbine, at Different Outputs when operating at 1,500 R.P.M.; Vacuum 28.5" and a Steam Pressure of 200 lbs., which is Superheated to 150° Fahr.

um. The most important reason why the Curtis turbine so greatly surpasses the steam engine in economy is that it

naturally increases at a rapid rate—the volume of steam with a 29-inch vacuum being double that with a 28-inch vacuum.

To handle high degrees of expansion it would, therefore, be necessary to make cylinders of steam engines very large, and this increase of size and weight of parts fixes a practical limit which cannot be passed without excessive cost and complication. In the turbine the highest degrees of steam expansion are easily provided for, and consequently a much larger proportion of the total work in steam can be utilized by turbines than by steam engines.

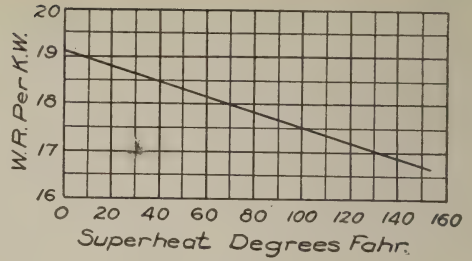

CURVE 4.
Curve Showing Water Consumption, in pounds per K. W., of 600 K.W. Curtis Steam Turbine, at Different Degrees of Superheating, when operating at 1,500 R.P.M.; Vacuum 28.5"; Pressure 140 lbs., and Delivery 600 K.W.

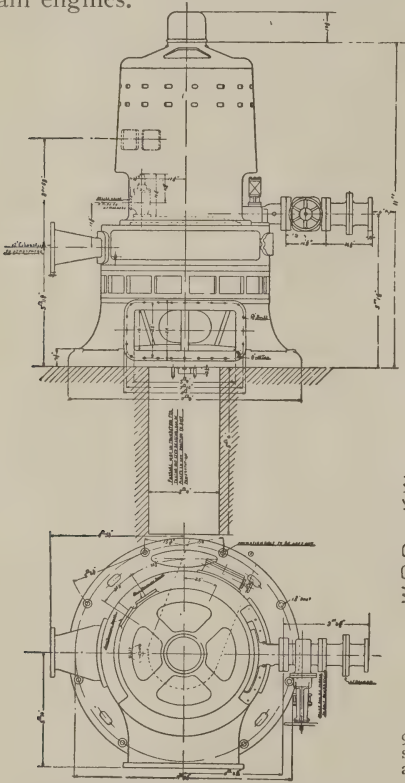

Plan and Elevation of 500 K.W. Curtis Turbine With Generator.

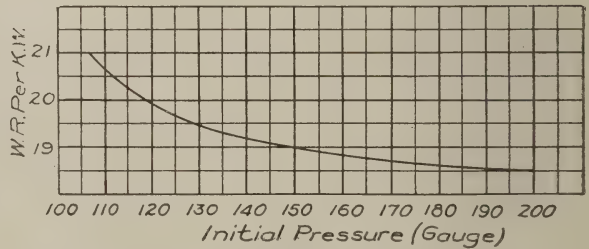
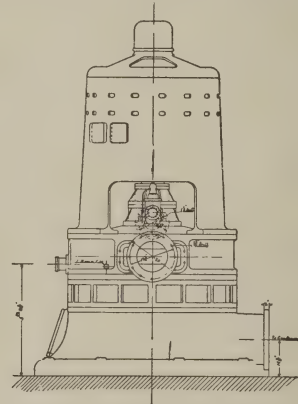

CURVE 3.
Curve Showing Water Consumption, in pounds per K.W., of 900 K.W. Curtis Steam Turbine, at Different Initial Pressures (as shown by Gauge), when operating at 1,500 R.P.M.; Vacuum 28.5" and Delivering 600 K.W.

There are other conditions in the Curtis turbine which make high degrees of vacuum more easily attainable than they are under ordinary conditions. The machine is so constructed that leakage of air into the vacuum chamber is easily rendered impossible. The leakage of air into condensing engines is considerable, and is generally not checked owing to

the small value of improved vacuum to an engine.

With turbines of the type here described no oil comes into contact with the steam, and consequently condensed water can be taken from surface condensers and returned to boilers. The use of surface condensers under such conditions renders unnecessary the introduction of air either in feed or circulating water, and consequently makes possible a very high

vacuum with small air-pumping apparatus.

The results shown by these curves are obtained from a machine of 600 kilo-

into operation in Chicago. This machine is expected to give considerably better steam economies than are shown by the accompanying curves, and will be su-

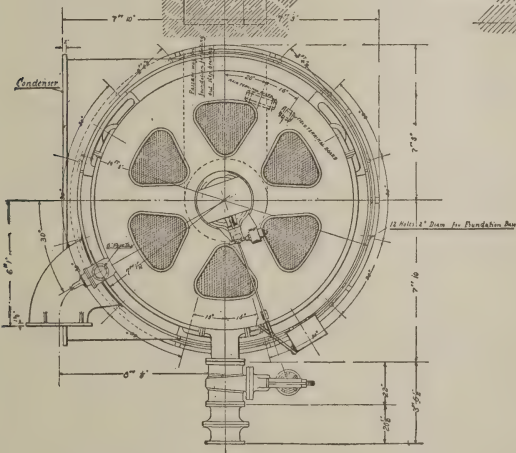
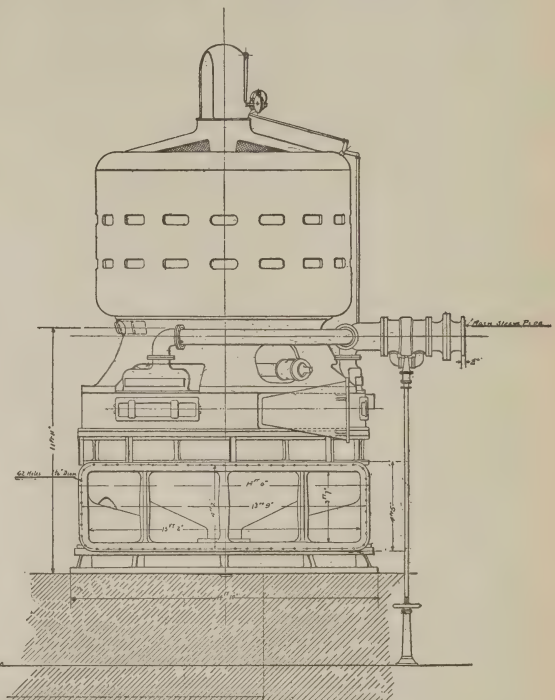
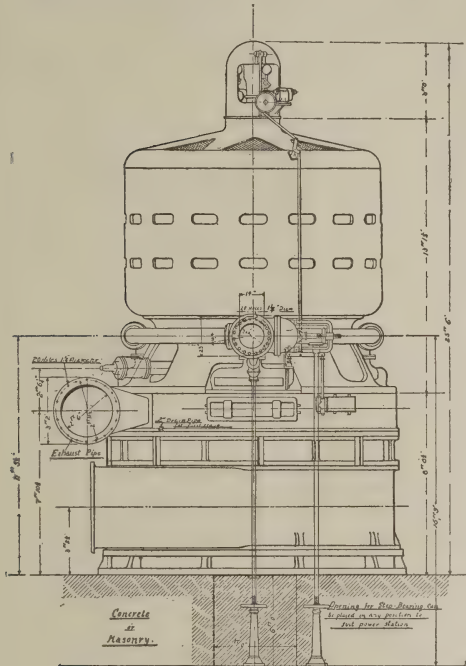

Plan and Elevation of 5,000 K.W. Curtis Turbine With Generator.

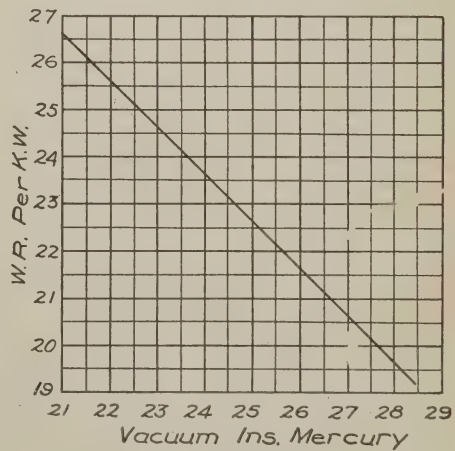

CURVE 5.
Curve Showing Water Consumption, in pounds per K. W. of 600 K.W. Curtis Steam Turbine, for Different Vacua as Measured in Inches of Mercury. Turbine Operating at 1,500 R.P.M., under a pressure of 140 lbs. of Steam and Delivering 600 K.W.

watts capacity, and are naturally inferior to results which are expected from the very large units which are now being built. It is hoped that very soon after the reading of this paper a 5,000 kilowatt unit, which is now complete, will be put

perior, particularly in the matter of light-load performance. The variation of ef-

efficiency in this machine from half load to 50 per cent. overload will not exceed 3 per cent.

The external appearance and dimensions of this 5,000 kilowatt unit are shown by one of the drawings which accompanies this paper, and another drawing shows this unit compared with an engine-driven generating unit of similar capacity. Each unit is shown as com-

ings which accompany this paper show a 500 kilowatt unit recently installed at Newport, and also a comparison drawn to the same scale between this 500 kilowatt unit and a cross-compound engine unit of equal capacity designed to operate at 100 revolutions per minute. The contrast here is even more striking.

If the extreme simplicity of the Curtis turbine is considered in combination with

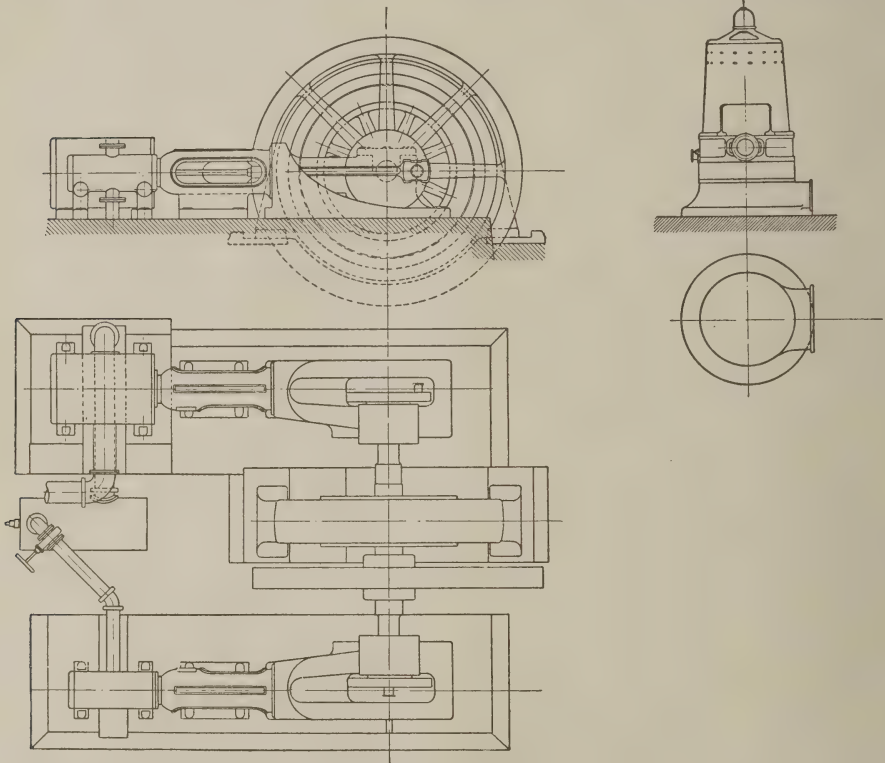

Comparison of 500 K.W., 100 R.P.M. Cross-Compound Engine and 500 K.W., 1,800 R.P.M. Curtis Turbine.

plete with prime mover and generator, one being the machine for Chicago, above mentioned; the other, one of the units which are operating in the Manhattan Railway Company's power station at New York. The comparison sufficiently illustrates the improvement which the turbine has introduced. The respective weights of these complete units, exclusive of foundation, are in the ratio of 1:8, and the saving in foundations alone is a very important item. Other draw-

ings which accompany this paper show a 500 kilowatt unit recently installed at Newport, and also a comparison drawn to the same scale between this 500 kilowatt unit and a cross-compound engine unit of equal capacity designed to operate at 100 revolutions per minute. The contrast here is even more striking. If the extreme simplicity of the Curtis turbine is considered in combination with

these figures and comparisons, it is easy to appreciate that a very great engineering advance has been accomplished. It has been conservatively estimated that engine units, like those in the Manhattan Company's station, can be replaced by turbines like that in Chicago, and that the cost of such replacement can be paid for by saving in operating expenses in three years.

Whenever an improvement has been effected in prime movers, the influence

upon engineering and business conditions has been very marked. When the release cut-off principle was introduced by Corliss a certain improvement in engine economy was effected, and although this improvement was accompanied by no diminution in cost, the change resulted in a very great activity in engine building and the renewal of most of the large mill engines in the country. It is, therefore, safe to predict that the influence of the steam turbine will be of

radical importance. The steam turbine is, on account of its high speed, particularly adapted to the driving of electric generators, and its introduction will consequently stimulate the use of electricity rather than other power transmitters.

In the past the most economical use of steam has been confined to the most expensive and elaborate plants, while in the future it will be within the reach of all where condensing water is available.

New Engineering Building for the University of Pennsylvania

PLANS have just been completed for a new Engineering Building for the University of Pennsylvania, to be located at the corner of Thirty-third and Locust streets, facing Dental Hall on Locust street, Philadelphia, Pa.

The building is to be 300 feet long and 160 feet deep, with a wing 50 feet wide on the west end extending 40 feet further to Chancellor street in the rear. It is to be three stories high, with a basement covering about one-third of the area. By a suitable scheme of terracing full advantage will be taken of the natural downward slope of the ground toward the east to convert the basement at that end into practically a first story. The total floor space available in the building will be approximately 128,000 square feet.

On the first floor, immediately adjacent to the main entrances, will be the offices of the heads of the departments.

A spacious laboratory for the testing of cements, mortars and concrete will

occupy the southeast corner. This room will contain testing machines of various types for tensile, compressive and bending tests, a briquette-making machine, immersion tanks, damp-closets, etc., and a number of individual work-tables, each completely equipped with an outfit of minor apparatus. It is intended to make special provision for investigating the effect of freezing on mortar and concrete by the installation of refrigerating apparatus.

The eastern side of this floor will be otherwise occupied by the main physical testing and hydraulic laboratories, both extending partly into the basement, as previously stated. The former will contain universal testing machines of various types, ranging in capacity from 30,000 to 200,000 pounds; machines for torsion, bending and impact tests, besides a complete outfit of extensometers, deflectometers, cathetometers, micrometers, etc.

The hydraulic laboratory will contain a pressure tank, 5½ feet in diameter and

37 feet high, having a total capacity of 5,800 gallons for experiments on the discharge through orifices and tubes, and two calibrated weir-tanks, 5 by 5.5 feet in cross-section and 34 feet long. These tanks will be provided with partially removable ends to permit also of observations of flow over submerged weirs and dams. Two weighing tanks, having each a capacity of 1,350 gallons, will be mounted on scales at the discharge ends of the weir-tanks, and will themselves empty by quick-discharge valves into the main supply tank directly underneath. This tank will have a capacity of 23,000 gallons and will be connected with the city water mains and, by overflow and drain pipes, with the sewer. It will be below the basement floor level, so that it may receive the discharge from any piece of apparatus either on the basement or first floor level. An eight-inch tubular well, 100 feet deep, will pass through the floor of this tank and will be utilized in connection with experiments on the efficiency of various forms of deep-well pumps and air-lifts. The pumping plant will consist of three units independently driven by variable-speed motors, so that they may be operated either separately or combined and at various speeds, thus ensuring a wide range in the rate of supply.

Various pipe circuits will be provided and connected with a 12-inch stand-pipe, extending from the basement to a height of about 65 feet, or somewhat above the main roof. From numerous connections along these pipe-lines water will be supplied to various forms of minor apparatus.

On the west end, opening out of the main hall, will be an instrument-testing room for the calibration of indicators, thermometers, calorimetric work with fuels, etc., and beyond that an electrical-standard room for the comparison and correction of electrical testing apparatus

of every variety. The remaining mechanical and electrical laboratories will be situated on a floor four feet below the entrance hall.

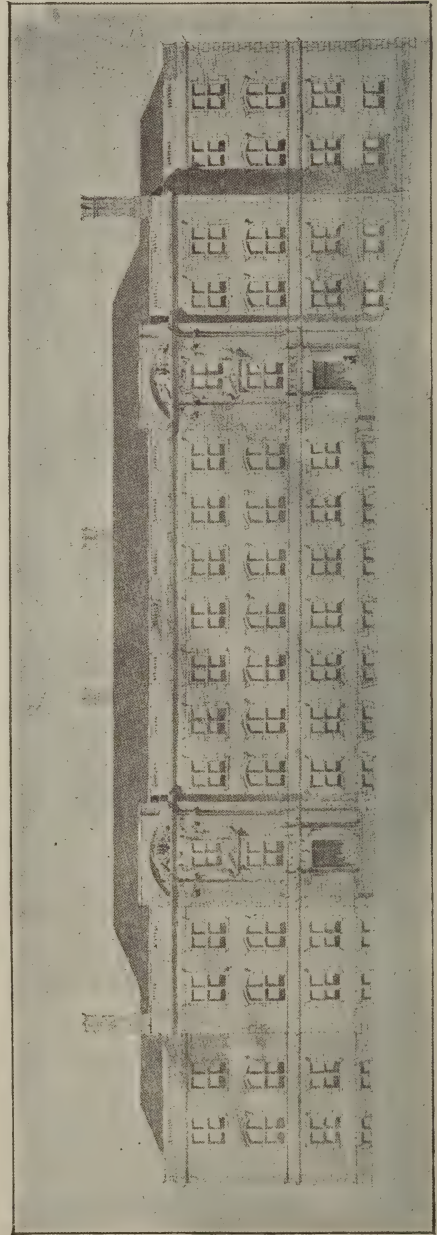

The New Engineering Building, University of Pennsylvania.

The central space under the skylights, about 200 by 50 feet, will be utilized entirely for workshops. In the western end

will be a foundry equipped with a small cupola, brass furnaces and light crane for handling flasks and ladles. A moderate sized sand-floor in the center, and a small core-oven and benches around the outside, will complete the equipment.

The wood-working and pattern shop will extend to the middle of the building and will be divided into two parts, the one intended for beginners and the other for students engaged on pattern work.

The tool room supplying the wood and iron shops will be placed directly at the center of the building. To the east of this will be an iron-working shop divided into two departments, one for beginners, the other for more advanced students.

The various forms of lathes, planers, drill-presses, etc., required in a modern shop will be installed, besides a number of electrically driven tools.

The eastern end of the shop space will be devoted to the forge shop, with accommodations for fifteen men working simultaneously. Collectively, the shops will accommodate about ninety men working at the same time.

To the west and north of the shops will be the mechanical laboratory and a part of the electrical laboratories. At the western entrance will be a dynamo and motor room in which direct-current work will be carried on. Provision for high-voltage and railway work will be made in the adjacent laboratory.

In the mechanical laboratory steam and gas engines will be installed; each installation being complete with its apparatus for doing the special kind of testing for which it is to be used. Certain engines will be used for valve settings, others for determining mechanical efficiency and others for determining the entire heat efficiency of the installation. A condensing apparatus and a small cooling tower for the steam engines

and a moderate sized suction producer in connection with the gas engines will make a complete working installation. A high-pressure water service with accumulators and belted and steam-driven air compressors will make it possible to carry on any experiments with hydraulic and compressed air transmission. A boiler of 100 horse power to supply saturated or superheated steam for experimental purposes will be installed near a small erecting-floor, on which any kind of machine may be mounted and quickly connected up. Special testing rooms will be provided for refrigerating work, for experiments on heat transmission through pipes and radiators, and for experimental work on fans. Apparatus will be installed for measuring power transmitted in various ways and for testing the materials used by the mechanical engineer. A large water-supply tank will be located above the third floor, and cisterns beneath the first floor will receive the discharge from the various machines. A number of water wheels now in the possession of the department, steel flumes for handling the water, and weirs and meters for measuring it, will afford facilities for laboratory work in this line.

Adjacent to the mechanical laboratory will be the electrical laboratory, in which all measurements to be made away from the machines will be carried on.

On the second floor a reference library and reading-room will occupy the central space on the front of the building. The library and stack at one end have been planned to hold about 20,000 volumes. The library is flanked on either side by a series of recitation and lecture rooms, which are continued along both ends of this floor.

Between the light-wells at the center of the building will be a students' assembly room with about 2,500 square feet of floor-space. Instructors' rooms

will be provided along the south side of the light-wells.

The rear portion of this floor for nearly the entire length of the building will be assigned to drawing-rooms. A separate room will be allotted to each class and an individual desk to each student, so that he may have free access to the same at all hours.

The extension on the west side will be utilized for an alternating-current laboratory, with facilities for two and three-phase work and photometric work. An instrument repair shop will be adjacent to this laboratory.

A room intended for the use of the engineering societies, a general supply store and the library stack will occupy the middle of the front of the building on the third floor, the space along the front being otherwise assigned to classrooms and to instructors' rooms along the south of the light-wells.

In the east and west wings spacious rooms will be set aside for engineering museums. The rear of this floor will be devoted entirely to drawing-rooms which, like the drawing-rooms on the second floor, will have the full advantage of north light through windows of ample dimensions.

The building will be heated by direct steam, the ventilation being provided for by electrically driven fans, supplying tempered air to the various rooms. The lighting throughout will be by electricity.

It is expected that the building will be completed and made ready for occupancy by the fall of 1904. It may be confidently affirmed that the University will then be in possession of unexcelled facilities for purposes of engineering instruction.

Germany at present disposes of 73 telegraphic cables, of which number 48 connect the different component parts of the empire, six serve as means of communication between the colonies, and 19 connect Germany with foreign countries. The existing 73 cables represent a length of 16,334 kilometers, one-third of which is State owned; the remaining two-thirds are owned by the German Submarine Cable Society and by the German Transatlantic Telegraph Company, both of Cologne. Notwithstanding the extraordinary activity of the last few years, Germany only owns about one-twenty-sixth part of the 379,614 kilometers of submarine cable actually in existence, against the more than two-thirds held by English investors.—*Ex.*

A Silesian inventor has patented an improved electrically-actuating raising and lowering apparatus especially adapted for operating the lifting tables of rolling mills. The table is raised and lowered by a lever operated from a crank shaft either directly by means of a link, or indirectly by a weight which is moved to and fro on the lever, and causes a preponderance of weight alternately on opposite sides of the fulcrum of the lever. In the case of three-high and universal rolls, the central roll is raised and lowered in unison with the tables by means of a lever similar to the preceding one, and operated from another crank on the shaft. The shaft is rotated from the motor through gearing including a self-locking worm gear, by which, or by means of a brake, the tables are retained in any desired position. The gearing also includes a friction clutch which can be automatically disengaged on the table reaching its highest or lowest position; the same result is obtainable by the use of a shifting belt gear.

Lessons in Steam Engineering

SECOND PAPER

By CHARLES J. MASON

IN our last paper the subject of heat was treated of and we shall now take up the application of heat to water, and explain the results obtained therefrom.

Water is a compound; consists of two gases, hydrogen and oxygen, combined chemically in the proportion of two (2) volumes of hydrogen to one (1) of oxygen. It is expressed symbolically thus: H_2O . By applying heat to water, *steam* is formed, which is water in a gaseous state. When water is gradually heated in a vessel small bubbles will be seen to slowly rise through it. These bubbles consist of air which is diffused through all natural water to the extent of about 4 per cent., and which is partially expelled by heating. As the temperature increases larger bubbles are formed at the *bottom* of the vessel, which rise a little way and are then crushed in and disappear. These bubbles consist of vaporized water or *steam*, which is formed in the hottest part of the vessel, but as they rise through the colder water above are cooled and condensed. This is the first process of *circulation*, a term which is frequently used by the steam engineer. The singing noise that is heard in vessels in which water is boiling is supposed to be caused by vibratory movements produced in the liquid by the formation and collapse of these vapor bubbles. As the heating continues the steam globules rise

higher and higher until they reach the surface and escape into the air. This agitation of the water is called *boiling*, or *ebullition*.

Now, all liquids do not boil at the same temperature, but the boiling point, as we say, of each liquid varies with circumstances. The nature of the vessel in which the liquid is has something to do with the boiling point, depending upon the attraction it has for the liquid. Thus, to glass and polished metallic surfaces it adheres with greater force than to vessels with rough surfaces. Before the liquid can be changed to vapor in boiling this adhesion must first be overcome.

Pressure upon the surface also influences or determines the boiling point of water. If water be boiled in the open air, the temperature of the boiling point depends upon the pressure of the atmosphere, and also upon the density of the water. When boiled in a regular boiler, with the valve left open, the same rule applies. But should the valve be closed so that no steam could escape, then the temperature of the boiling point will depend upon the pressure of the steam and the density of the water as referred to.

It is reported by travelers that meat cannot be cooked by the ordinary method of boiling upon high mountains. The reason for this is that owing to the diminished pressure of the air at such height the water boils at a lower tempera-

ture and does not get sufficiently hot to do what is required. The boiling point thus fluctuates with the barometric column. The natural variations of atmospheric pressure at the same level make a difference of four (4) degrees in the boiling point of water.

If the weight of air pressing upon a liquid affects its boiling point, for the same reason the weight or *density* of the water itself must affect it. When salts are dissolved in water they render it heavier, in consequence of which its boiling point is raised. Some salts, however, raise it more than others. Water that is saturated with common salt (100 water to 30 salt) boils at 224 degrees F.; with chloride of calcium, at 264 degrees F.

Water in contact with highly heated metallic surfaces does not boil or vaporize. Notice how a globule of water will dart and dance about upon a hot stove. The reason offered why the globule does not evaporate from a red hot surface is that a stratum of steam is formed under it which props it up, so that it is not really in contact with the iron, and steam being a non-conductor also cuts off the heat. Water enters upon the spheroidal state between 288 and 340 degrees F. of the hot surface; but when the temperature falls the steam no longer sustains the drop; it is brought into contact with the iron and is at once exploded into vapor. From the foregoing the reader should understand the nature of the danger attending the pumping in of cold water into a boiler whose plates had become overheated from shortness of water.

If water be confined in a strong vessel it may be heated to any desired point of temperature, but if exposed to the air it is impossible to raise its temperature above its natural boiling point. All the heat that is added after boiling commences is carried away by the vapor. The rapidity with which water is raised

to the boiling point depends upon the amount of heat which is made to enter it. But when this point is reached a comparatively small quantity of heat will maintain it there as well as more. Water boiling violently is not a particle hotter than that which boils moderately.

So far we have been treating of the application of heat to water in its *sensible* form. There is also another kind or form of heat. Sensible heat is generally defined as that which affects the thermometer; *latent* heat is that which does not affect the thermometer. Bodies get latent heat when they are passing from solid state to liquid state and from liquid to gaseous. The latent heat can be recovered, however, by bringing the body back from the state of gas to that of liquid, and from that of liquid to solid.

Water is a body which may be seen under the three forms of matter referred to—solid, liquid, and gaseous. When solid it is ice; when liquid it is water, and when gaseous it is steam.

The theory of latent heat may be clearly understood by a study of the following experiment: Take a vessel in which is a quantity of ice. As long as it remains ice it may be any degree of heat below 32 degrees F.; but the moment it begins to melt, a thermometer placed in it will stand at 32 degrees F. If we subject this vessel, with its contents, to the action of heat, we will observe the following events: The ice will begin to melt, but the thermometer will continue to register 32 degrees as long as a bit of ice remains, in spite of the fact that a large amount of heat has entered to melt the ice. The heat that has so entered has not affected the thermometer, and is known as the *latent heat of water*.

But the instant the last piece of ice is melted the thermometer will begin to rise till the water boils, when it will stand at 212 degrees F.; and, although the water

goes on receiving heat after this, the instrument will stand at 212 degrees until the water has all boiled away. The heat that has entered the water from boiling till it becomes steam is called the *latent heat of steam*. The latent heat of water is 143 degrees F., and the latent heat of steam at the pressure of the atmosphere is 966 degrees F.

Take a quantity of water at a temperature of 32 degrees and boil it. Let us suppose it takes one hour to do so. Now keep it boiling until it has all evaporated, and note the time from boiling till evaporated and it will in this case be five and one-third hours. We shall now see how the 966 degrees of latent heat is found.

Temperature of boiling point.....	212 degrees.
Temperature of the water at first..	32 “
Heat that has entered the water in	
1 hour.....	180 “
	*5 1-3. “
	900 degrees.
	60 “
Heat received in 5 1-3 hours....	960 degrees.

Another experiment will also illustrate the point in view. Take two glass globes and put one pound of water at 32 degrees F. in one and 5 1-3 pounds in the other, and connect them by a glass tube. Place a lighted lamp under the globe that has the one pound of water in it and keep it there until all the water has been turned into steam. As steam is formed it flows over to the other globe, where it is condensed, and its heat is imparted to the 5 1-3 pounds of water. At the instant the last drop of the one pound of water is turned to steam the 5 1-3 pounds of water in the other globe commence to boil, thus showing that the heat in the steam generated from the

* The 5 1-3 is a figure of convenience rather than one of exactness; actually, it should be a little more than 5 1-3 in order to obtain the 966 degrees, which has been found to be correct.

one pound of water is sufficient to boil 5 1-3 pounds of water.

The heat necessary to boil the one pound of water is, as before, 180 degrees, therefore the latent heat of the steam is 180 times 5 1-3, equals 960.

This theory of latent heat of steam affects the steam engine materially; the heat necessary to form steam, instead of being only 212 degrees, must be 960 degrees plus 180 degrees or 1146 degrees per steam tables, or nearly 5½ times as great; therefore the coal consumed to produce this heat must be nearly 5½ times as great also, and the cold condensing water must be nearly 5½ times as great as it would be if it were not for latent heat. It should be remembered by the reader that we have said that the sensible heat of steam varied with the pressure. So also does the latent heat of steam alter; but as the sensible heat increases with the pressure, the latent decreases. The total heat is the sum of the sensible and latent heats:

Latent	966 degrees.
Sensible	180 “

Total 1146 degrees

The total heat alters very little, roughly speaking; we may say that by the same amount the sensible heat is increased, the latent heat is decreased; so that the sum of the two is always the same.

The cycle of events which occurs during the application of heat to water is as follows: When bodies of unequal temperature are placed near each other the hot body tends to part with its heat to the colder body until the temperature is equal in each. When no transfer of heat occurs the bodies must then be of equal temperature. The transfer of heat may take place in any of the following ways: by *radiation*, *conduction*, or *convection*.

Radiation is the giving off of heat from bodies in rays, which radiate in all directions in straight lines. For example, the heat in the burning fuel in a furnace is transferred to the crown and sides of the furnace by *radiation*; it passes through the furnace plates by *conduction*, and the water is heated by *convection*.

Convected, or carried, heat is that which is transmitted from one place to another by currents. Because water is a bad conductor of heat the method of heating it by convection must be applied, in consequence of which boilers are made particularly with this point in view. Engineers speak of it as circulation, and no boiler can be spoken of as good unless it is so constructed as to admit of good circulation of the water within when heat is applied.

NOTE.—In our last issue the following paragraph, which forms the conclusion of Mr. Mason's first paper on "Lessons in Steam Engineering," was inadvertently omitted:

One unit of heat equals 778 units of work. Now, to convert units of heat into units of work, multiply the units of heat by the number, 778, and to convert units of work into units of heat, divide the units of work by 778. Horse power expressed in heat units $\frac{33000}{778} = 42.41$

One of the omnibuses belonging to the Star Omnibus Company, running between Camberwell Green and King's Cross, London, England, has been fitted with the electric light. There are two incandescent lamps in the interior of the vehicle, and it is stated that passengers can read with ease in any part of the 'bus. The current is supplied from ac-

cumulators placed under the driver's seat, which store sufficient electricity to furnish light for seven or eight hours. If the experiment proves successful all the 'buses on this route will be shortly similarly fitted. Similar experiments have been repeatedly made in the metropolis without success.—*Ex.*

A new electric heater is of rather novel construction. It consists of a series of plates of enamelled iron, about 2 feet 6 inches long by 6 inches wide, which are placed together in couples, and fixed in a vertical position in a suitable frame by means of screws. Any number of these couples can be placed together with two or three inches of space between them, according to the amount of heat required. The two plates of each couple are placed face to face, but are kept a small distance apart by a strip of asbestos sheeting, which is inserted between the plates all around their outer edges. The space thus left between the plates is filled with finely powdered gas-retort carbon, the electric conductivity of which varies according to the degree of fineness to which the carbon is ground. Into this carbon electric wires are led, one at each end of the couple, with one in the middle. The middle wire carries the positive current, and the end wires the negative. The current, therefore, flows from the middle of each couple to the two ends. The wires are, of course, insulated from the plates. The resistance of the powdered carbon to the passage of the current causes the mass to heat up to about 190 degrees Fahrenheit. In the commercial form of heater there is to be a small switch at the bottom, which can put in contact one or all the couples at the same time, and so regulate the temperature.—*Ex.*

Alternating-Current Magnet Experiments

By F. H. DOANE

A NUMBER of most interesting experiments with an alternating-current magnet may be made. Most of the following experiments were originally produced by Prof. Elihu Thomson, of Lynn, Mass.

The necessary apparatus is of simple construction. The magnet can be constructed as follows: The core is made up of a bundle of very soft iron wires. No. 14 or No. 16 B. & S. wires may be used. The core is seven inches long, and when the wires are bound together in the form of a cylinder the core should be about one inch in diameter. Wind tape on the core for insulation between the coil and core. The coil consists of six layers of No. 18 B. & S. copper wire, double-cotton covered. Wind on 100 turns to a layer. The coil should be about six inches long. Mount the coil vertically on a small baseboard. On the board mount an incandescent key-lamp socket. A general view of the apparatus is shown in Fig. 1.

The magnet *m* is mounted at one end of the baseboard, the lamp socket *s* at the other end. Binding posts *f* and *g* are provided. In some of the experiments a 16 candle power 104-volt lamp *l* may be used. In other experiments an Edison plug fuse is substituted for the lamp, and the magnet connected directly across the 104-volt alternating

current circuit. A brass support *b* is used to form a bearing for the shaft of a disk *d*, of 1-32-inch copper. The lower bearing may be made in the head of a small screw *e*. A small sheet of thin copper *c* is provided for a shading sheet. A piece of soft iron one inch wide, $\frac{1}{2}$ inch thick and about eight inches long, is bent so that the end of the bent portion can be placed against the top of the core and the straight portion will lie parallel to the magnet. Make a copper ring out of No. 1 B. & S. copper wire. Make the joint in the wire as good as possible. Bevel off the end and rivet them together. The diameter of the ring should be a little more than the outside diameter of the coil, so that the copper ring may be slipped on or off the coil. It is possible that two or three rings of

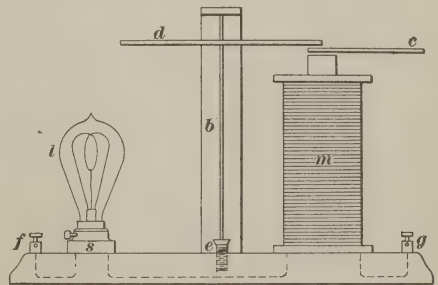

FIG. 1.

different sizes of copper wire must be made to get one that is just right for the experiment.

For the first experiment, put in the Edison plug fuse in place of the lamp, and connect *f* and *g*, Fig. 1, to the line wires of a 104-volt alternating-current circuit. An alternating current flows through *m*, and an alternating-magnetic flux is set up in the core and in the air near the core. If the copper ring is held just around the top portion of the coil, the magnetic flux cuts across the copper ring and induces in it an E. M. F. As the ring forms a short circuit, a small induced E. M. F. is sufficient to send a large current through the ring. The current heats the ring in a few seconds so that it cannot be held by the hand. The interaction between the magnetic lines set up around the ring by the current in the ring and the magnetic lines emanating from the pole of the magnet is such as to give a strong repelling action between the ring and magnet. If the ring is of proper size and weight, it should, upon being released by the hand, fly off in the air away from the pole of the magnet, as represented by the position of *r'*, Fig. 2. If ring *r* is held just below the middle

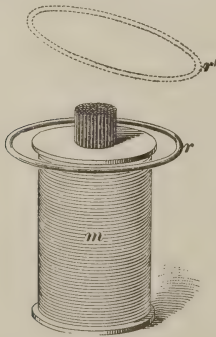

FIG. 2.

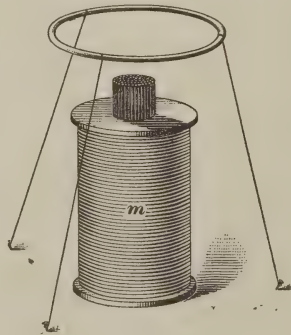

FIG. 3.

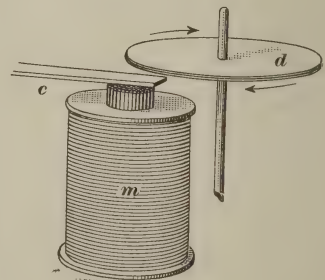

FIG. 4.

of coil *m* and released, it will be forced downwards toward the baseboard. The ring may be held by three strings fastened to the ring and to the baseboard, as shown in Fig. 3, so that the ring remains suspended in the air, by reason of the strong magnetic repelling action be-

tween the ring and the magnet. This experiment may require some adjustment, but should be successfully made. The ring and coil act in the same relation as the primary and secondary coils of a transformer.

Adjust the disk *d*, Fig. 1, in position so that the edge of the disk overlaps the top of the magnet pole. The shading copper piece *c* is slid under the disk *d* and placed so that it covers one half of the pole piece. In Fig. 4 it covers the side of the pole piece opposite to the observer. Close the circuit through *m*. The pivoted disk *d* begins to rotate. The direction of rotation will be from the unshaded portion of the pole piece toward the shaded portion. By changing the position of the shading piece *c* so that it shades the side of the pole toward the observer, the direction of the rotation of *d* is reversed. The portion of disk *d* in which is induced the eddy currents is continually attracting itself to, and trying to hide behind, that part of the interposing sheet in which parallel eddy currents are induced. There is a mutual attraction between the magnetic

field set up by the eddy currents in *c* and the magnetic field set up by the eddy currents in *d*. The disk *d* therefore rotates toward the shading piece *c*. A number of experiments can be carried out along this line. Rotate a hollow copper globe supported by water in

a glass vessel held immediately over a shaded pole. Instead of a globe use a thin cup-shaded disk.

It is interesting, if there is access to a direct-current line of 110 volts and an alternating-current line of 104 volts, to try the following experiment: Take out the plug fuse in the lamp socket and put in its place a 16 candle power 110-volt lamp. Connect the apparatus to a 110-volt direct-current line and note the brightness of the lamp. Disconnect from the direct-current circuit and connect to the 104-volt alternating-current circuit and you will note that the lamp is much more brilliant on the direct-current circuit than on the alternating-current circuit. The ohmic resistance of the coil is low, but when the coil is placed on the alternating-current circuit the impedance of the coil is considerable, so that only a small current flows through the lamp. If the coil alone were placed across the direct-current circuit it would burn out at once. Owing, however, to its high impedance, it can be connected alone across the alternating-current circuit.

Connect the coil and lamp across the alternating-current circuit. Take the bent piece of iron and place it so that the bent end touches the core and the other portion of the iron piece lies parallel to the core. Note the difference in the brightness of the lamp when the piece is not in use and when it is in use. The iron piece decreases the reluctance of the magnetic circuit and thereby increases the impedance of the coil. The lamp should show somewhat dimmer when the piece of iron is used.

The above-mentioned experiments are only a few of the large number that can be performed with an-alternating-current magnet.

American Institute of Electrical Engineers.

At a meeting of the Board of Directors of the Institute, held April 24, the following resolutions were adopted:

Resolved, That the head of the electrical engineering department in each of the universities and technical schools in which local Institute meetings have been held during each year, be requested to select from the theses of each year's graduating class the one which in his judgment is of superior merit and is a valuable contribution to electrical engineering work.

Resolved, That a committee of three be appointed as a committee on theses to receive the theses which may be presented and to select those which are of superior excellence. The committee shall designate to the Board of Directors of the Institute those theses which in its judgment are worthy to be printed in full or in abstract in the transactions of the Institute.

Resolved, That theses to be presented to the Institute shall reach the secretary not later than July 15.

One of the most powerful three-phase current motors in existence has just been started in an Augsburg, Germany, cotton spinning mill. This motor generates about 2,000 horse power, and that at an angular velocity not exceeding 114 revolutions per minute under a tension of 2,900 volts. The motor, weighing about 40 tons, is directly coupled to the shaft, which is simultaneously operated by several hydraulic turbines. The electric plant of this mill also feeds other three-phase motors developing 400, 300, 100, and less horse power, as well as three-phase alternators which are coupled directly to hydraulic turbines. One of these alternators generates 900 horse power, the other two 1,100 horse power each.—*Ex.*



Digest

Engineering Literature of the Month



Distribution of Magnetic Field by Explosions.

(*Science.*)

Prof. F. E. Nipher, of St. Louis, Mo., has been experimenting in the production of ether waves by means of explosions. This line of research was suggested by Young's account of his observations of five solar outbursts in 1872, which were each accompanied by sharp fluctuations in the magnetic tracings at the observatories at Kew and Stonyhurst, England. Since the experiments began, volcanic explosions have produced such ether waves, which have been simultaneously recorded over the continents of Europe and America.

The apparatus used by Prof. Nipher in his experiments was a transformer, consisting of concentric coils wound upon brass tubes. The outer tube was five inches in diameter and six feet long, wound with over four thousand windings of No. 16 wire. This coil was traversed by a continuous current from a storage battery. Within this, and separated from it by an air-space of an inch, is a secondary coil of equal length having over twenty-five thousand windings of No. 25 wire. This coil is connected to a D'Arsonval galvanometer. Within the tube on which this coil is wound is a smaller brass tube, within which a train of black gunpowder is laid. This tube is open at both ends, and has practically no recoil when the explosion is made. When hung by a bifilar suspension on cords ten feet in length, the recoil is

about an inch. When the exciting current is small compared with the capacity of the battery, the galvanometer reading is very steady. When the train is exploded, a sudden and marked throw of the galvanometer results, which could be accounted for by an increase in the permeability of the long explosion chamber. The deflection reverses when the field is reversed. The hot gases liberated in the explosion are all diamagnetic, and tend to decrease the observed effect. In two cases the galvanometer deflection was in the opposite direction from that stated above, and this is being further inquired into. When seven tubes between the two coils are simultaneously exploded, only slight effects could be obtained, and these deflections are wavering, or to and fro, in character. A wire was threaded through the inner combustion tube, through which a current of three amperes was passed. This circuit was opened and closed with no visible effect. The galvanometer circuit is shielded by tin-foil, which is also connected with the explosion tube and grounded. Sparks an inch long to the tin-foil produce no result. When the explosion tube is removed from the transformer, and taken near the galvanometer, or the storage battery, no deflection is produced by the explosion.

An explosive mixture of gases from water electrolysis under atmospheric pressure produces a much less violent explosion, and produces a correspondingly less effect. The scale reading of the

galvanometer changes by over twenty divisions with the heaviest explosions and an exciting current of 0.6 ampere. With smaller explosions or feebler currents the effect is diminished. No deflections can be produced by striking the table upon which the transformer rests, nor by striking the transformer itself, even when it moves slightly under the blow. The secondary and primary coils are held rigidly in fixed position with respect to each other.

Arrangements have now been made to place the explosion tube in the focal line of a parabolic cylinder of metal, the galvanometer coil being in the focal line of a similar mirror. Either or both are to be surrounded by an exciting coil.

Screenings for Use as Fuel.

(Science and Industry.)

The writer describes his experience in using screenings—a mixture of fine pea coal, dust, and more or less dirt—taken from the cleanings of the bins in the local coal yards, as fuel for a small steam plant, consisting of a 60 horse power horizontal tubular boiler. He had found that under the previous management the coal bills had been excessive, soft coal costing \$4.75 to \$5.50 per ton of 2,000 pounds, which was 2 per cent. a ton more than the same fuel cost at the seaboard, 45 miles distant, while the screenings could be bought for \$2 or \$3 per ton. After nineteen years of service the boiler is in first class condition and doing more work than ever before, while the fuel bills have been reduced something like 40 per cent. since screenings have been used as fuel.

Burning the screenings by using a forced draft under the grates called for some changes in the boiler arrangements, the first and most important being a change of grate bars. The ordinary fixed grate bars were removed and re-

placed by others, similar in general shape to the regular straight bars, with a rib on the outer edge, underneath, but instead of the regular openings the top was cast flat and solid. Rows of holes were then drilled through this flat surface, about three-eighths of an inch in diameter and three inches apart, thus giving the grate surface, when the bars were all in position, the appearance of a large, coarse screen, or riddle, with narrow slotted openings between each pair of bars to allow for the ordinary expansion and contraction. The ash pit doors were carefully fitted at all the joints and securely fastened. A pressure blower, about two feet in diameter, was installed on top of the boiler, and the outlet connected by a pipe in the rear of the ash pit, next to the bridge wall. This arrangement was one of necessity, rather than choice, owing to the setting of the boiler relative to other surroundings. A preferable arrangement would have been to bring the air supply pipe through the front wall of the ash pit. This would have given a more even distribution of the air under the grate surface, and brought the direct blast toward the bridge wall and rear of the grate, instead of the front.

At a convenient position in this air supply pipe an ordinary slide damper was placed, operated by a steam pressure regulator connected with and directly controlled by the pressure of steam in the boiler.

This was so arranged that when the pressure in the boiler was at a low point the damper would be open to its full capacity. As the fire was renewed and the steam pressure rose, the damper would gradually be closed until the high pressure point was reached, when the air supply would be entirely cut off from entering the ash pit. As the fire burned down and the steam pressure was low-

ered, the weight on the lever arm of the regulator gradually descended again, opening the damper and allowing the blast of air to enter and bring up the fire to its normal condition. This arrangement was found to work very satisfactorily, the boiler pressure being kept closely within the required limits and giving the fireman his undivided time to look after his fire.

By placing the blower on top of the boiler the air was taken in at a temperature considerably above the normal, which resulted in a decided gain over forcing cold or cool air directly under the fire.

Then, again, the blower acted in a measure in the capacity of an exhaust fan, thus removing the impure air and dust from the boiler room, leaving it in a more desirable condition for occupancy.

Water Power in Electrical Supply.

(Electrical Review.)

Alton D. Adams presents a comprehensive summary of that development by which falling water is generating hundreds of thousands of horse power for electrical supply to millions of population. Ten years ago this application of great water powers to the industrial wants of distant cities had hardly begun.

Electrical supply from transmitted water power is now distributed in more than fifty cities of North America. These include Mexico City, with a population of 402,000; Buffalo and San Francisco, with 352,387 and 342,782 respectively; Montreal, with 266,826, and Los Angeles, St. Paul, and Minneapolis, with populations that range between 100,000 and 200,000 each. North and south these cities extend from Quebec to Anderson, and from Seattle to Mexico City. East and west the chain of cities includes Portland, Springfield,

Albany, Buffalo, Hamilton, St. Paul, Butte, Salt Lake City and San Francisco. To reach these cities the water power is electrically transmitted, in many cases dozens, in a number of cases scores, and in one case more than two hundred miles. In the East, Canada is the site of the longest transmission, that from Shawinigan Falls to Montreal, a distance of 85 miles.

From Spier Falls to Albany the electric line is 40 miles in length. Hamilton is 37 miles from that point on the Niagara escarpment where its electric power is developed. Between St. Paul and its electric water power station, on Apple River, the transmission line is 25 miles long. The falls of the Missouri River at Canyon Ferry are the source of the electrical energy distributed in Butte, 65 miles away. Los Angeles draws electrical energy from a plant 83 miles distant on the Santa Ana River. From Colgate power house, on the Yuba, to San Francisco, by way of Mission San Jose, the transmission line has a length of 220 miles. Between Electra generating station in the Sierra Nevada Mountains and San Francisco is 154 miles by the electric line.

These transmissions involve large powers as well as long distances. The new plant on the Androscoggin is designed to deliver 10,000 horse power for electrical supply in Lewiston, Me. At Spiers Falls, on the Hudson, whence energy goes to Albany and other cities, the electric generators will have a capacity of 32,000 horse power. From the two water power stations at Niagara Falls, with their 21 electric generators of 5,000 horse power each, a total of 105,000, more than 16,000 horse power is regularly transmitted to Buffalo alone; much the greater part of the capacity being devoted to local industries. Electrical supply in St. Paul is drawn from a water power plant of 4,000 and in Min-

neapolis from a like plant of 7,400 horse power capacity. The Canyon Ferry station, on the Missouri, that supplies electrical energy in both Helena and Butte has a capacity of 10,000 horse power. Both Seattle and Tacoma draw their electrical supply from the 8,000 horse power plant at Snoqualmie Falls. The Colgate power house, which develops energy for San Francisco and a number of smaller places, has electric generators of 15,000 horse power aggregate capacity. At the Electra generating station, where energy is also transmitted to San Francisco and other cities on the way, the capacity is 13,330 horse power. Electrical supply in Los Angeles is drawn from the generating station of 4,000 horse power, on the Santa

stations, scattered within a radius of ten miles, and with 4,200 horse power total capacity, are the source of electrical supply in Mexico City.

Another ten years, says the writer, we will see the greater part of electrical supply on the American continent drawn from water power.

Electrically Operated Roller Bridges
(*Western Electrician.*)

An illustrated description of two bridges recently constructed in Chicago. These are of the roller-lift type, invented by the late William Scherzer.

The State street bridge has a total length of 249 feet 8 inches, and the length from center to center of end bearings is 161 feet 8 inches. A clear waterway of 140 feet in width is left between the foundations when the lifts are raised. The bridge is a two-truss structure, the space between the trusses being 40 feet 6 inches wide, and accommodating a roadway and two street car tracks. A sidewalk 12 feet wide is left on the outer side of each truss. The lifting speed of the bridge is about 40 seconds.

Two electric motors are used to raise each side, and they are placed, with their gearing, underneath on the outside. The motors are of the Westinghouse street railway series type, with a capacity of from 50 to 56 horse power. They are operated by a series-parallel control on a 500-volt direct-current circuit. Between the shaft of each motor and the rack on the bridge there is a set of four reduction gears.

Each lift is controlled separately by an operator stationed in a small house at his end of the bridge. At the right is the switchboard, which contains the necessary ammeters, voltmeters, switches, fuses, circuit breakers, etc., for operating both sides of the bridge. At the left are two series-parallel controllers,

CITIES WITH ELECTRICAL SUPPLY FROM WATER POWER.

City.	Miles From Water Power to City.	Horse-Power of Water-Driven Stations.	Population.
Mexico City.....	10 to 15	4,200	402,000
Buffalo.....	23	*16,000	352,387
Montreal.....	85	266,826
San Francisco....	{ 222 154	{ 15,000 13,330 }	342,782
Minneapolis....	10	7,400	202,718
St. Paul.....	25	4,000	103,065
Los Angeles.....	83	8,600	102,479
Albany.....	40	32,000	94,151
Portland, Ore....	90,426
Hartford.....	11	3,600	79,850
Springfield, Mass.	6	3,780	62,059
Manchester, N.H.	13.5	5,370	59,987
Salt Lake City...	36.5	10,000	53,531
Portland, Me.....	13	2,660	50,145
Seattle.....	8,000	80,671
Butte.....	65	10,000	30,470
Oakland.....	142	66,900
Lewiston, Me....	3	10,000	23,761
Concord, N. H....	4	1,000	19,632
Helena, Mont....	20	10,770
Hamilton, Ont...	35	8,000
Quebec.....	7	3,000
Dalles, Ore.....	27	1,330

*Power Received.

Ana River, and from two stations, on Mill Creek, with an aggregate of 4,600, making a total capacity of not less than 8,600 horse power. Five water power

each controlling one side of the bridge. The operator in this tower can operate both lifts of the bridge if necessary, while the other operator has equipment for only his side.

The electric power is obtained from the lines of the Chicago Union Traction Company, and a reserve supply connection will probably be made with the Union Elevated Railroad Loop. There are four locks on the bridge, and they are operated by electric solenoids from the towers. Indicator lamps are provided for the operators to show the position of each half of the bridge and to show also the condition of the locks. At the center of the bridge are electric-signal lanterns, which show red and green lights at night and red and green targets by day, according to the established river regulations. At the entrances to each side of the bridge are pneumatically controlled gates, which are operated from the controlling houses.

There are four brakes on each side of the bridge, two for each set of machinery. One of these is a hand brake and the other is an electric solenoid brake, being set by gravity and released by electricity. The brakes are 30 inches in diameter and are provided with three-inch friction bands. Ten incandescent lamps are provided for the machinery on each side and five for each house. The wires under the river and to the different motors and lights are carried in lead-covered iron-armored cable. In addition to the above equipment, there is a ten horse power motor driving a centrifugal pump on each side for pumping out the water from the bridge pits.

The Randolph street bridge has three trusses, dividing the structure into two roadways of 22 foot clear width each. The total length of the bridge is 267 feet 5 inches, and between centers of end bearings it is 169 feet 2 inches long.

As with the State street bridge, a clear waterway of 140 feet is provided. The electric motor equipment is different, in that each span is operated by three 37 horse-power General Electric motors, connected to a cross shaft, and controlled by a controller. This bridge has no electric locks, but its signal lights and other equipment resemble closely those of the State street structure. One distinguishing feature, however, of the design of this bridge is that the motors, instead of operating a straight rack underneath, gear into a curved rack at the ends of the trusses.

Oil Grooves Rejected.

(The Economist.)

R. S. Grant argues against the method of mangling bearings by groove cutting, stating that as the groove offers practically no resistance to the oil, the greater portion of it flows along the-grooves and out at the ends of the bearings, entailing an enormous supply of oil in order that the bearings may catch enough to lubricate the journal. He states that a great mistake often made by engine builders is the drilling of oil holes nearer to the ends of bearings than to the centers, in bearings where more than one oil hole is required; as a consequence the oil will not flow as freely to the center as to the ends, and this leaves the center in danger of overheating unless the bearing is flooded with oil. Get the lubricant to the center of a bearing and it will work its way to the ends without fail and without grooves. A great many railroads have adopted this "no groove" system; the Great Northern Railroad Company has every locomotive of their line thus equipped. All oilways and grooves are filled up with metal and fitted the same as if they had never had grooves cut in them. The Great Northern Railroad

Company has made a saving of over 50 per cent. in oil alone.

He filled all oil grooves in the main bearings, crank pin brasses and, in fact, all bearings in the engines of the steamships Northwest and Northland of the Northern Steamship Company of Buffalo, with white metal, and changed the position of oil holes to midway between center and ends; some of the holes he counterboxed on the bearing side and from some cut a duct about $\frac{1}{2} \times \frac{1}{2}$ inch toward the center of bearing, from the oil hole. Crank pins of those engines are 14 x 16 inches; speed anywhere from 98 to 120 revolutions per minute; results after filling up oil grooves and with the new cups—bearings ran perfectly cool; saving of 70 per cent. oil, and last, but not least, there was an absence of oil splashes and a goodly reduction in material and time for wiping.

He has also found bearings which had no oil grooves to have a film of oil over the entire bearing surface, top and bottom, 48 hours after stopping the engines, while those with grooves were dry on top and almost dry on the bottom bearing surface, and sometimes dry altogether. This condition is often the cause of those mysterious hot bearings shortly after starting an engine; of course, the oiler neglected to oil up (or down) before starting. Bearings without do not require oiling up before starting, as there is always a film of oil around the bearing left from the previous supply. How often do engineers find the center of a bearing black and scored while the ends are perfect? Or one end black and scored while the other is all right? Oil grooves carry the oil to the ends, leaving center dry, and one oil groove carries it all to one end. Mr. Grant believes that engineers will profit by using the no-groove system.

Telephone Switchboard Destroyed by Trolley Currents.

(The American Telephone Journal.)

Earl F. Edmunds gives an account of the destruction of the central office plant of the Independent Telephone Company, at Little Falls, N. Y., by fire. The fire was caused by a high tension current that had been turned on for a test by the local trolley company, which had just entered the town, the first electric railway ever constructed in Little Falls. Fifteen minutes after the railway current had been turned on the telephone switchboard and exchange were entirely destroyed. The trouble was caused by the gross negligence of the street car company. One of its span wires which support the trolley line was allowed to rest on a messenger wire, supporting one of the telephone cables. The insulation of the span from the trolley wire was defective in some way, for as soon as the current was turned on it found its way over the span wire to the messenger wire, and from there to the lead sheath of the telephone cable and then to the switchboard through the distributing frame, etc. The current did not go through the protectors, but over the sheathing, thus finding its way to the switchboard. Not a single wire in the cable or any of the outside wire plant or sub-stations was damaged. The lead sheath of the cable was grounded to protect the plant from just such accidents, but the grounding failed utterly of accomplishing its purpose. Fifteen minutes after the fire started it was extinguished, but even in that short space of time at least \$10,000 damage was done. The toll board, which was on the other side of the room from the main switchboard and connected thereto by a number of trunks, was damaged slightly, but only from the flames. The power plant, consisting of charging and ringing ma-

chines in duplicate, duplicate storage batteries, and a fine power board, was very badly damaged, and may have to be replaced.

Steam From Oil versus Transmitted Electricity.

(Pacific Coast Miner.)

In a paper read before the annual convention of the California Miners' Association, Mr. A. M. Hunt presents some peculiar facts and observations on "Crude Oil as Fuel."

This distinguished electrical engineer has had occasion to make special studies of fuel oil for a number of years, especially during the three years in which he has been general manager of the Independent Electric Light and Power Company of San Francisco. His findings regarding the relative efficiencies of oil and coal are more conservative than those commonly asserted by advocates of oil fuel.

The most interesting part of his paper is his demonstration that, with the most efficient installations of electric and steam power, the former to be transmitted 200 miles to San Francisco, as is now done, and the latter to be generated locally with fuel oil, the latter power can be made much the cheaper under the conditions of widely varying loads that actually exist in San Francisco. This has a vital relation to the great problem of cheap power for San Francisco and the bay region, in the solution of which electric energy from the Sierras and that generated with cheap oil fuel are the main and competing factors.

In making a comparison of the cost of power developed at tidewater, San Francisco, using fuel oil, with the cost of electric power transmitted from a distant mountain stream, he assumed plants

capable of delivering 50,000 horse power and the distance of transmission to be 200 miles. The steam plant should contain eight 5,000-kilowatt steam turbine driven alternators, with the best types of boilers and auxiliaries. The price of oil was taken at 55 cents per barrel. The hydraulic plant of equal capacity was to be driven by impulse wheels and the energy transmitted at 60,000 volts.

The cost of installation per horse power in the steam plant would be less than in the hydraulic plant unless the latter enjoyed extremely favorable conditions, such as he did not know to exist in California. The labor required in such plants would be about the same. The items of cost taken as a basis of comparison were the interest, depreciation and taxes on the cost of the pole line and the cost of caring for it, and, in the steam plant, the cost of fuel, water and miscellaneous supplies, the cost of the power plants and labor being eliminated from the comparison.

Such an electric transmission line, to transmit 50,000 horse power 200 miles with 10 per cent. loss, and constructed with chief reference to stability, would cost \$3,500,000. The cost of operation of the water power plant remains the same, regardless of the number of hours the current is used. Assuming that interest, depreciation and taxes would be covered by 12 per cent. on the investment, there would be, according to the basis of comparison, a total charge against the pole line of \$420,000 yearly, or \$8.40 per horse power per year. Under similar circumstances, operating the steam plant 24 hours daily for 365 days, the cost of output for fuel, water, etc., would be \$19.68 per horse power per year, showing a very great advantage for water power. However, there is no instance in which power is taken for 24 hours daily. These figures do not rep-

resent the actual cost of power, but only the cost of items not common to the two cases compared.

Mr. Hunt stated that he had worked out a second comparison, based on the actual operating conditions as they existed in San Francisco, which conditions must be met by people entering the city with transmitted power. During the winter time practically all consumers take an increased load and make heavier demands in the evening for a limited time. On the street railway system the maximum load each day is at least three times the average load figured on a 24-hour basis. In making this comparison he had used the actual fuel costs and experiences in a plant carrying both power and lighting load and a part of the San Francisco street railway system. The conditions were such that he could not give in detail any record of operation, but he gave assurance that the figures used were absolutely correct. The comparison showed that under existing conditions, and on the basis stated, the cost for delivery of power, from the hydraulic plant was \$8.40 per horse power per year, while with the steam plant the figure becomes but \$5.72, showing that under the conditions the steam plant has the advantage.

German Telephone Statistics.

(The American Telephone Journal.)

Max Staengel, in an illustrated description of the German Imperial telephone system, gives some interesting statistics.

According to the Statistical Bureau of the German Government the telephone industry stood as follows at the beginning of the current year :

Miles of urban telephone lines.....	31,400
Miles of interurban telephone lines....	19,300
Miles of special lines.....	978

Wire plant under German control exterior to the empire, as follows :

Miles of line.....	19
Miles of special line.....	28

To serve preceding line mileage, the following wire mileage is required :

Wire miles, urban lines.....	485,000
Wire miles, interurban lines.....	158,000
Wire miles, special lines.....	5,420
Outside of Empire :	
Wire miles.....	145
Wire miles, special lines.....	72

Total wire miles..... 648,637

Of the urban wire mileage there are 145,000 miles of wire in conduits.

The number of instruments installed is as follows :

Subscribers' stations.....	230,993
Extension instruments.....	57,899
Pay and public instruments.....	2,943
Total.....	291,835

In acknowledging receipt of the resolutions adopted by the Paris Chamber of Commerce, favoring the metric system, Secretary of War Root said that he considers the universal adoption of the system as inevitable within a short time, and added that it would have been adopted before but for the habit attached to the old system.

Pole-finding paper of the ordinary type is not always handy when required, and it is well to know of a convenient substitute. For this purpose common blue prints are admirably adapted. All that is necessary is to cut a slip from an old print, moisten it, and apply it to the terminals of which it is desired to ascertain the polarity. In a few seconds the blue paper in the neighborhood of the negative terminal will be bleached, the ferro-prussiate of potash being decomposed, with the liberation of potash at the negative. We have tried this suggestion, and find it to be perfectly successful.—L'Industrie Electrique.

A Twenty-ton Switching Electric Storage Battery Locomotive

THE electric storage battery locomotive described below has been designed with special reference to the economical handling of material in mills or other manufacturing establishments. It frequently happens that a single carload of raw material has to be distributed at various parts of the works, and in such cases much costly rehandling can be saved by shifting the entire car from point to point and discharging each portion of the load exactly where it is required. A similar economy can be effected by collecting the finished product at the different buildings and loading each consignment directly into its proper car. The locomotive in question is used for shifting cars while loading or unloading in this manner, and also for transferring material in course of construction from one shop to another.

The simple and rugged construction of this locomotive reduces the expenses for maintenance to a minimum, probably less than the cost of shoeing the horses, which it replaces. The operating expenses consist of the cost of power required to charge the batteries and the pay of one man. Even if discharging current is supplied from an independent steam-driven generator, it is cheaper than any other method of handling cars, as there is no waste of energy when the machine is not in operation. A steam locomotive requires a licensed engineer

and an assistant to operate it, and it greatly increases the fire risk.

The disastrous consequences which can result from the sparks of a steam locomotive when used near highly inflammable material are illustrated by a recent explosion at the plant of the Northwestern Star Oil Company in Minneapolis, in which eight men and two women lost their lives. The explosion is believed to have been caused by the sparks from a switch engine, which ignited some oil while it was being transferred from the tank cars to the tanks in the basement of the wrecked building. In cotton mills the danger is fully as great, owing to the great inflammability of the material handled.

A further advantage of the storage battery locomotive is that it can be run on any track or switch without the expense of the erection and maintenance of a trolley wire.

A locomotive of this type has recently been installed at the works of the Massachusetts Cotton Mills of Lowell, Mass. The original buildings have been improved and extended to meet the requirements of the growing business, and new structures have been added, from time to time, until the entire plant covers a considerable area. The freight siding is separated from one of the two principal storehouses by the main business

street of the city, and from the second of these storehouses by the canal which supplies the turbines of the mill. It is necessary to deliver carloads of baled cotton at either or both of these buildings. Neither a steam nor a trolley electric locomotive is permissible in the storerooms on account of the fire risk.

Before installing the locomotive the cars were shifted, one at a time, by three horses harnessed up tandem, as shown in Fig. 1. The storeroom at the canal is



FIG. 1. Moving Freight Cars With Horses.

so constructed that the horses would have no means of exit if driven in ahead of the car, and this necessitated sending it in "on the fly." The bridge across the canal is just wide enough for the car tracks, and the horses had to turn out before reaching it. To get up speed, it was necessary to start some distance up the track, the "tag holder" (the man at the coupling), the driver and the horses all traveling at their best gait. At the proper moment the "tag holder" unhooked the "tag," or rope, fastened to the traces, and ran out from in front of the car. The consequence of a slip or false step was self-evident. In the case of a heavily loaded car the horses were unable to give it sufficient momentum, and the operation had to be completed by the loading gang, as shown in Fig. 2.

The locomotive, pushing three standard freight cars, is shown in Fig. 3, and it is shown alone on a larger scale in Fig. 4.

The locomotive is built for the standard 4 feet by $3\frac{1}{2}$ inch gauge, and fitted with M. C. B. standard couplings, making it suitable for use with any ordinary railroad car and on any standard railroad track. The length over the bumpers is



FIG. 2. An Awkward Corner.

21 feet 4 inches, and the height from the railhead to the top of the cab is 12 feet 1 inch. The wheel base is 7 feet 6 inches, and permits the operating of the locomotive over a comparatively smaller turntable. It weighs about twenty tons, and runs at a speed of from two to four miles per hour on level track.

As will be seen from Fig. 4, the locomotive is perfectly "double ended," the cab being located directly in the center. This makes a very desirable arrangement for switching work, which calls for

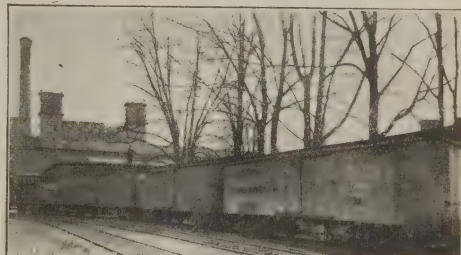

FIG. 3. Electric Locomotive Hauling Freight Cars.

operation in both directions with equal facility. The batteries are contained in the sloping compartments at either end. This symmetrical disposition distributes the weight evenly on the four wheels,

and, as each of these is a driver, the entire weight of the locomotive is usefully employed in traction. The wheels and axles are driven from the gear cases in the cab by means of Renold silent chains suitably enclosed. These chains are the only portion of the driving gear situated below the car body, the motors and gear cases being mounted in the cab, where they are readily accessible and always under the immediate notice of the operator. Under these favorable conditions any reasonably reliable man can be depended upon to maintain the electrical equipment in proper working condition. This is considered a most important feature of the design, as it is a matter of common experience that any inaccessible piece of mechanism will be run with no attention until it finally re-

fuses to operate. When such a condition is reached, a complete shut down is necessary to enable more or less costly repairs to be made by an expert electrician or mechanic.

The battery was furnished by the Electric Storage Battery Company, the elements being mounted in tanks of extra depth to prevent the electrolyte from splashing over the top. In mounting the battery special attention has been paid to protecting it against injury due to the shocks to which the locomotive is exposed in switching.

There are two motors, specially wound, for the service. By connecting the two motors in series or parallel, and by varying the arrangement of the fields, an efficient speed control is obtained without wasting any of the energy of the bat-

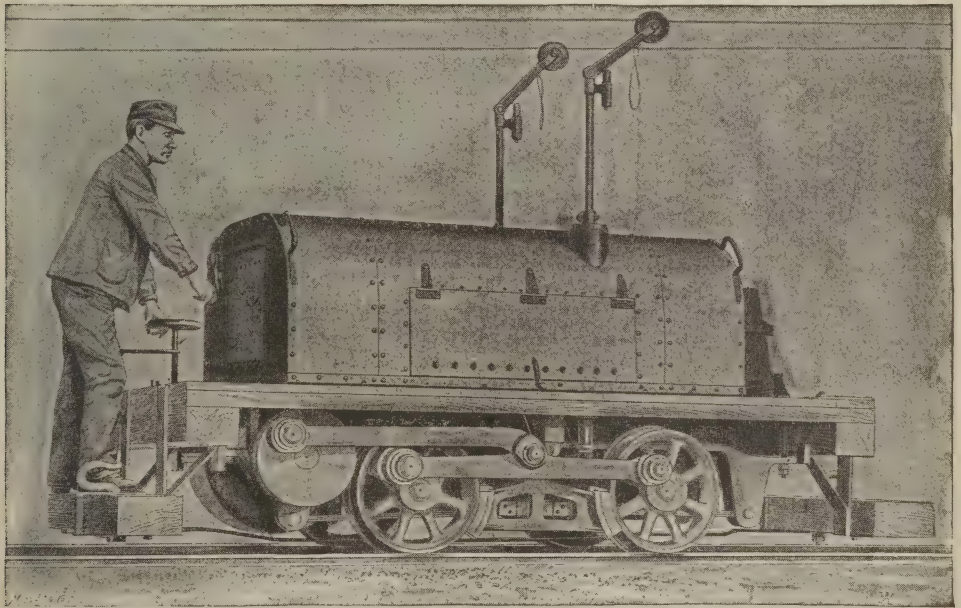

FIG. 4. 20-TON Electric Storage Battery Locomotive.

tery by passing it through a resistance. The controller is of the standard vehicle type, and has two levers, which control every desired motion of the locomotive. The reversing lever is set to point in the direction in which the locomotive is to move, and the second lever controls the speed. These levers are mechanically interlocked, as in the case of a trolley car controller, so that the motors can only be reversed when the speed lever is in the off position. The locomotive may be run with the controller in any notch, there being no transition

is used for connecting the motor to the gear case. There is a separate gear case for each of the two motors. It will be seen that the driving gear consists of two parts which are exact duplicates of each other. In an emergency, one motor could be cut out entirely and the locomotive operated by the remaining motor, but with a reduction of hauling capacity.

The speed reduction of the gear case is so proportioned to the safe discharge of the batteries, the safe capacity of the motor, and to the weight of the lo-



First Electric Locomotive Made by the C. W. Hunt Company, and the Third Made in the United States.

point on which a careless operator might leave his lever and burn out the apparatus.

As already mentioned, the speed reducing gearing is located in the cab, instead of being beneath the car body. All the gears are machine cut and run in a bath of oil in fully enclosed gear cases of the C. W. Hunt Company's standard type. The same company's regular flexible and insulated coupling

comotive, that neither the batteries nor the motors can be dangerously overloaded.

The driving axles are made to the M. C. B. standard dimensions and run in "Hunt" patent roller bearings, which reduce the friction at these points to an inappreciable amount. The wheels are shrunk in place and have chilled treads and flanges of M. C. B. standard size and shape. A powerful brake is con-

veniently located in the cab. An alarm gong is also provided.

Experience has shown that in light switching service the batteries can be recharged at various times during the day while the locomotive is waiting between hauls. For heavier service it may be necessary to charge during the noon hour or after working hours in the evening. The battery is automatically protected during charging by well-known safety appliances, which open the circuit if the current is excessive and also when it drops so low as to indicate that the battery is fully charged. The precise arrangement of the charging station depends very largely on the details of the electric plant available, and the builders of the locomotive are glad to advise their customers as to the methods to be employed in each particular case.

This locomotive is placed on the market by the C. W. Hunt Company, of West New Brighton, Staten Island, N. Y. Smaller locomotives, intended for use on the "Hunt" narrow gauge track, have been built by the same company for a number of years.

A recent newspaper dispatch states that Sherman Hobson, a railroad man of Pueblo, Colo., has just perfected an appliance which, if all proves true that is claimed for it by its inventor, will greatly reduce railroad collisions and save thousands of lives annually. The new appliance is a sort of looking glass to be hung on each side of an engine to enable the engineer and fireman to see the roadbed for six miles, both in front and in the rear. The chief value of the invention is that it does not make any

difference if the road is curved or straight. The instrument works on the principle of a mirage, and it has been named by its inventor as the "mirage-scope." It has been tested from Denver to Grand Junction on the Denver and Rio Grande and the Colorado Midland, and also passed favorable tests on the Colorado Southern and Missouri Pacific. Application has been made for patent.

A scientist, in pointing out some of the most practicable data in testing iron and steel, lays down a simple rule to start with, namely, that in any case where a fracture of iron gives long, silky fibers of a leaden hue, the fibers cohering and twisting together before breaking, it may be considered a tough, soft iron. Further, a medium, even grain, mixed with fibers, is a good sign, while a short and blackish fiber indicates badly refined iron, a very fine grain also denoting a hard and steely iron which is apt to be cold, short and hard to work with the file. Again, coarse grain, with a brilliant crystallized fracture and yellow or brown spots, denotes a brittle iron, cold-short, working easily when heated and welding well. Nitric acid will produce a black spot on steel—the darker the spot the harder the steel—while iron, on the contrary, remains bright if touched with that acid. Good steel in its soft state has a curved fracture and a uniform gray luster, but in its hard state a dull, silvery uniform white. Again, good steel will bear a white heat without falling to pieces and will crumble under the hammer at a bright heat, while at a middling heat it may be drawn out under the hammer to a fine point.



Current Engineering and Scientific Notes

Abstracts from the Foreign Papers



Volcanic Origin of Natural Gas and Petroleum.

(*The Petroleum and Mining News.*)

In a paper read before the Canadian Mining Institute, Mr. Eugene Coste, the president of the Institute, deals with the origin of petroleum. He opposes the theories of organic formation, of which Prof. Edward Orton is a firm believer in and defender, Mr. Coste contending that none of the processes called on by these organic theories are to be witnessed anywhere in nature and air.

First, continues Mr. Coste, it is quite certain that the decomposition of animal bodies, as taking place in nature to-day and doubtless during all ages, is so rapid that the decay or combustion is complete before the entombment in the sedimentary rocks of these animal bodies, preserved in any way, can possibly take place. This is, no doubt, why instances are so rarely cited in geology of partially decomposed and preserved remains of animal bodies being found; only most exceptional cases, such as a few remains preserved in the antiseptic waters of peat bogs, or a few frozen remains of *elephas*, are given; but these exceptions only confirm the rule, which is, that when there is anything left at all it is the shell or bones or their molds or casts, and no trace of the body is to be found. The fact that a few shells have sometimes been found full of petroleum is a conclusive proof that this oil is a subsequent infiltration into the shell, as in the case of silt, silica, pyrite, calcite,

and many other minerals—filling shells—a modicum of oil is all each shell would contain if the petroleum originated from the body, and invariably when petroleum is found in fossil shells it is also found in the porous or seamed strata in which the shells are embedded, showing that the infiltration and impregnation have been from without.

Second—It is also equally certain that there is but one normal process of decomposition and preservation of vegetable organic matter in nature to-day and in ages past, and that is the decomposition of it into carbonaceous matter, viz., peat, lignite and coal. This process is in active operation in the world to-day, as it always has been, and it is the only normal process, “coeval with the kingdoms of life,” that geology teaches us. Not one single authentic instance can be adduced from the actual normal processes of nature of any decomposition of organic matter “primarily” into petroleum.

Then, since animal organisms were never entombed in the rocks, and since vegetable life was quite insufficient before the carboniferous age, how can the theories of organic origin be adduced to explain all the oil and gas found below the carboniferous; and that means all the enormous quantities of oil and gas of the lower silurian limestone of Ohio and Indiana, and it also means almost all of the very large quantities of oil and gas developed in the last forty years along the Appalachian belt, which has been found under the coal in the lower

and sub-carboniferous, Devonian, and silurian; and, much more, in other fields. The fact often cited by the numerous exponents of the organic theories, as in the above quotation of the late Prof. Orton, that by destructive distillation petroleum and gas can be obtained from coal or carbonaceous matter, and also from fish, oil, lard oil or linseed oil, etc., will not serve here at all, for not only was there too little to distill in the rocks prior to the carboniferous, but what little there was was not distilled, and is to be found there to-day, undistilled, as the paleozoic oil rocks of the oil regions of North America have certainly remained unaffected by metamorphic agencies, and have never been subjected to the heat necessary to effect this distillation of organic matter. Nor have the rocks of the Texas section; and yet we have seen that petroleum, gas and asphalt are found in them from the ordovician to the quaternary.

In fact, if this distillation had taken place there would be no coal fields anywhere, as they would all have been changed into coke beds.



A Novel Theory of Magnetism.

(*Verhandlungen des Vereins fuer Eisenbahnkunde.*)

An interesting theory of magnetism is that advanced by Herr Zacharias in a paper read before the above society. He considers that we are astray in supposing that a live solenoid produces a magnetized force, parallel to its axis, which polarizes the particles of iron in its core. He believes that the current in the solenoid creates a reduction of ether pressure in the core, and that magnetic force is entirely an electric pressure phenomenon. There is no such thing as magnetic attraction; an armature is forced

against the poles of its magnet by the pressure of the ether on its particles.

As an example in which the ordinary theory fails to give an adequate explanation of the observed phenomena, Zacharias takes the ironclad magnet. According to the ordinary theory, the edge of the tube which surrounds the coil should form one pole of the magnet, the end of the core forming the other pole. When the lines of force are mapped out by filings this is found not to be the case. The majority of the lines of force pass from the end of the core to the middle of the tube. The present theory of magnetic leakage supposes that the number of lines of force which are to be found on any path is inversely proportional to the resistance of the path. The resistance of the path from the end of the core to the edge of the tube must be very much less than from the end of the core to the middle of the tube, and yet we find the greater number of lines of force passing along the latter path. Thus the magnetic circuit theory appears to be quite inadequate to explain the actual distribution of lines of force about the ironclad magnet.

Take as another example the field of force about such a magnet as is often used for dynamos and electromotors, of horse-shoe shape, with a single magnetizing coil on the yoke. The magnetic circuit theory would lead us to expect the strongest field between the poles where the armature would be placed. The distribution of the iron filings shows that this is not the case; the strongest field is at the ends of the magnetizing coils, and the lines of force appear to prefer the high resistance path through the air between ends of the magnetizing coil, to the low resistance path through the pole pieces and the short air space between them.

Heating and Ventilation of Railroad and Other Shops

AT a recent meeting of the New York Railway Club an interesting discussion took place upon the subject of heating railway shops and other one-story buildings of the same nature. While such buildings are very simple in construction they are not so simple as might appear in regard to the problem of effectively and efficiently distributing heat and air. On account of the large amount of roof, wall and window surface the loss of heat is very great, and also, because of this and the relatively great height of the building considered as a single room, there is a tendency towards unequal distribution of the heat, the warm air rising to the roof and the cold air flowing to the floor, where it renders the workmen uncomfortable. It is important, then, not only that a sufficient quantity of heat should be delivered to the building, but also that it should be delivered where it will do the most good.

If an attempt is made to supply the heat directly by means of steam or hot water coils the best results are not obtained. The vicinity of the coils is apt to be uncomfortably hot from the heat radiated directly therefrom, while places at a distance are disagreeably cold. The heat transmitted to the air of the room by contact and convection from the coils is largely lost, since the hot air rises vertically and imparts its warmth to the roof and skylights. It is also to be objected to this system of heating, that it makes no provision whatever for ventilation, the

extended system of steam or water pipes is subject to damage by freezing during the coldest weather, and steam pipes have been shown to be frequently the cause of fire where they came in direct contact with wood or other inflammable materials.

Due principally to the reasons which have been given above, the direct system of heating for work of this character is falling into disfavor and is being superseded by the fan or hot-blast system. The apparatus required for the latter consists usually of a steam coil for heating the air, an engine or motor-driven fan for propelling the air through the heater and to its destination in the shop, and a system of piping or ducts leading it where it is needed. The heater will contain a considerably less length of pipe than would be required for direct heating, due to the higher velocity of the air over the pipe surfaces. The blower is additional equipment, but its use would be justified on the score of ventilation alone, something which is hardly considered at all in the direct system of heating. The exhaust of the engine is usually turned into the heater, thus obviating any loss from that source.

The distribution of the air by means of pipes should be so carried out that the lower part of the room is kept at a comfortable temperature, while at the same time no disagreeable drafts are produced. It has been found that by properly proportioning and directing the delivery flues most satisfactory results can be se-

cured. Illustrating this point some very interesting examples were cited at the meeting mentioned above by Mr. C. H. Gifford, of the B. F. Sturtevant Company. He said: "In the first place, if you desire air or almost any other form of gas or substance at any particular place, at any particular time, the best way is to provide a suitable conduit to deliver it there, and I would add, if there is any difficulty, which there may be, by air blowing on any individual workman, it is a simple mechanical detail to rectify it, and if you are unable to predetermine where the men or machines are to be located in a building, you can simply have an adjustable discharge opening from the pipe delivering the air, and if, perchance, it blows upon some one there is generally some space near the person to which the air can be directed and therefore cause no inconvenience whatever.

"As an example of what can be accomplished by distribution, I have in mind a machine shop, that of the New York Shipbuilding Company, which as a machine shop is not dissimilar to one designed for railroad work. They have a building which, I believe, is about 1,100 feet long, about 250 feet wide and 82 feet high. The proposition was to heat one-half of this building and leave the balance of it unheated. It was a problem that came to me, and I must say that I was a little 'phased' at attempting to heat one end and not have any interference from the other end. We, however, conceived the idea that there could be a partition put across the middle of the building, about 12 feet high, and we could then bring the heated air down to the zone which it was desired to heat, which was not over 8 feet above the floor, and in that way we could perhaps confine the air in the space, and not have very much effect on the rest of the building. It was something of a speculation and rather a bold attempt, when you

consider entering into a guarantee which might involve a serious loss; nevertheless it was done.

"The apparatus is arranged under the landing platforms of the gallery which surrounds the shop, so that it is out of the way of the cranes. Pipes are carried along beneath the runway of the cranes and branches are brought down on the posts and discharge the air towards the floor, the outlet being in the form of a Y, which is adjustable.

"We were very much gratified after the plant was started to find that it performed just as was expected it would, and it is surprising to note the difference in temperature between the two sides of that partition; it is almost the same as when you pass from the building out-of-doors. The result is simply due to the fact that the air was brought down and continually pressed down into the space which it was desired to heat."

Further emphasizing the advantages of correct distribution, Mr. Gifford says: "It is possible in some cases to introduce \$50 worth of additional pipe to carry the air where it is most needed, so that you can, on account of this, leave out \$100 worth of heating apparatus—that is, you can get equal results by using smaller apparatus and less steam."

The adoption of the fan system renders the control of the heating apparatus and of the ventilation ideal. During very cold weather, or in the morning, when the building is being heated up, the air supply may be drawn from within the building itself, thus effecting a great economy of heat. In some buildings having a very high cubic space per occupant sufficient ventilation during the winter time will be supplied by the leakage of air through doors and crevices about the windows, by transfusion, etc. Quoting Mr. E. T. Child, also of the Sturtevant Company, some of these advantages are as follows:

"First, a great convenience in handling, since the entire heating system of a building may be controlled from one point.

"Second, efficiency and economy, by controlling the speed of the fan and reducing the length of pipe to which steam is supplied, leaving more steam available for other purposes.

"Third, the fact that the entire heater coil is in a steel housing makes the danger from fire much less than with many pipes passing through partitions of wood.

"Fourth, in the summer time it gives the opportunity to ventilate the shops.

"This, I think, is very important. Some shops are very apt to become overheated in the summer time, and a current of cold air may be drawn from a basement, making them much more habitable.

"The pipes should be so arranged that the air will not be discharged directly upon the workmen; it is also true that hot air will do the most good if it is put where it is needed. If the space around the walls of a building is properly heated one may never worry about the center, as that will keep warm.

"We have found, therefore, that the most satisfactory heating will result from numerous pipes discharging on the outside walls at a point about 6 feet to 8 feet above and directly towards the floor. These pipes should be located from 25 feet to 40 feet apart, depending upon the character of the building. This arrangement causes hot air to be blown downward, whence it spreads on the floor, keeping it warm before the air has a chance to follow its natural tendency and ascend to the roof. Hot air has a very bad faculty of getting up in the trusses, and if you blow the air directly at the floor and get the floor warm, at the same time keeping the outside of the building warm, your problem is practically solved.

In the case of an underground duct it is well to use short outlet pieces which will discharge the air along the walls at the floor.

"At the works of the Fore River Ship and Engine Building Company they have an overhead pipe system, with drops on the walls, which was put in according to the regular practice. Later they added 50 per cent. to the buildings and are now heating it with the same apparatus—that is, we picked out a fan heater which we considered to be the proper size for that particular building and it worked in a perfectly satisfactory manner. Later the ship company added 50 per cent. to the length of the building. We extended the piping and carried drops on the walls every 30 feet, blew the air on the floor with ample outlets on the ends, and in the coldest weather the heat of the building, which is 50 per cent. larger than we would care to guarantee with our apparatus, was perfectly satisfactory to them. Their success is entirely attributed to the excellent system of air distribution.

"At the shops of the Atchison, Topeka and Santa Fe Railway Company the underground system was adopted and low horizontal outlets were provided which distribute the air at the floor and along the walls. This is an extremely large shop, the contents being about four or five million cubic feet. The shop is heated by four large apparatuses and the underground ducts extend almost entirely around the building. The pipes are not over three feet high, the air being discharged horizontally along the floor and I understand that the building is very satisfactorily heated.

"The galvanized iron pipe system, with drop pipes on the walls, has been used at the new shops of the New York, New Haven and Hartford Railroad, at Readville, Mass., with excellent results.

"The following general classification of railway shops may be made:

"First—Machine, erecting and car shops.

"Second—Paint shops.

"Third—Roundhouses

"The second and third require special treatment. Paint shops require to be practically dustless and, consequently, the air velocities must be low. The temperature must be higher, and it is customary to arrange to circulate the air in a much more thorough manner than in shops of the first class.

"This is done in the Pennsylvania Railroad shops at Altoona by means of ducts and in the New Haven shops, at Readville, by a similar overhead system. There has been a great deal of hesitation among railroad men about installing the hot blast apparatus in paint shops. They are afraid of getting their varnish dusty. But I might name a dozen or so paint shops all over the country. For instance, the Boston and Albany shops at Allston, the New Haven shops at Readville, and several Western shops, all of which are heated with the hot blast system by a very ample distribution of air. The circulation is brought about by a counter-exhaust system, which circulates the air, returning the whole or a part to the apparatus. There are two ways of establishing this return of the air, one by an underground duct system, and the other by an overhead galvanized system. In the Pennsylvania Railroad shops at Altoona we have an installation that has been in a dozen years. I believe it is one of the first we put in that returned the air from underground and back to the fans, using very ample distribution of air pipe in the discharge.

"In the Readville shops the air is brought back by means of an overhead galvanized pipe. In this way circulation is kept up in all parts of the room and

thereby the paint is dried much more rapidly than it would be by any other system where the air in the room is practically still.

"Roundhouses have been much neglected up to recent years, but of late they have been receiving better attention. Their proper heating is a problem of no little moment.

"A little official comment on this subject may be interesting. The following clippings are culled from the Proceedings of the American Railway Master Mechanics' Association, 1902:

"A. Van Alstine, in describing an ideal roundhouse, says: 'It is heated by hot air from heater and fan, which passes around the house through an underground duct; on the inside circle it is distributed to pits through the underground pipes.'

"On page 141, under Heating and Ventilation, we find the following: 'Nearly all large roundhouses of recent construction are equipped with fan systems, these being considered as furnishing the ideal method of heating. Various methods are employed to distribute the hot air into pits, the chief point of interest being the method of delivering the air under the engines and tenders for the purpose of quickly melting snow and ice.'

As further touching upon the subject of paint shops, Mr. Gifford stated that he had been told by a prominent railroad engineer, "that aside from the question of heating the shop, the drying of the paint and varnish is a chemical question, and for that reason the advantage of the hot blast system lies in the fact that you can handle large quantities of air, so that you have an active circulation and a rapid impingement of the air upon the painted surface, causing a rapid oxidation of the paint and varnish."

The Electrical Age

Incorporated April, 1902

CHARLES A. LIEB, - - - - PRESIDENT

New York, June, 1903

Volume XXX

No. 6

Published Monthly.

Subscription, \$1.00 per year. Single Copies, 10 Cents.
(\$2.00 Per Year to Foreign Countries.)

20 BROAD ST., NEW YORK. Telephone 1628 Cortlandt.

THE ELECTRICAL AGE (Incorporated)

Entered at New York Post Office as Second Class Matter.
Copyright, 1902, by THE ELECTRICAL AGE.

TO ADVERTISERS

Changes for advertisements and new advertisements **must** be in this office by the **20th** of the month to be included in the issue in the month following. The advertising pages carry printed matter measuring five and a half by eight inches. Cuts intended for use on these pages should be made to accord with these measurements.

Correspondence and semi-technical articles, with suitable photographs for reproduction, or cuts, are invited. Accepted matter will be promptly paid for. We cannot be responsible for any unsolicited manuscripts, but when stamps are enclosed all unavailable matter will be returned. Postage must always be fully prepaid. Cuts to be available for illustrating articles must conform to the column or page measurements. The columns are $2\frac{1}{2}$ inches wide. Cuts for single column use should not exceed that width. Cuts to go across the page should not be more than five inches wide, and full page cuts may not exceed $4\frac{1}{2} \times 8$ inches.

IN accordance with the call of Mr. C. F. Scott, a meeting of the nominated representatives of the five organizations named by Mr. Andrew Carnegie in his gift of \$1,000,000 to the four national engineering societies and the Engineers' Club for a building for their joint use and occupancy was held, pursuant to call, at the Engineers' Club, in New York City, on the evening of Friday, May 15, 1903. There were present, on behalf of the American Society of Civil Engineers, Messrs. Noble (president), Wilgus and Pegram; on behalf of the American Institute of Electrical Engineers, Messrs. Scott (president) and Martin; on behalf of the American Society of Mechanical Engineers, Messrs.

Dodge (president), Charles Wallace Hunt and Hutton; on behalf of the Institute of Mining Engineers, Messrs. Ledoux (president), Dwight and Kirchoff; on behalf of the Engineers' Club, Messrs. Kafer (president), Redding and Fletcher.

The meeting was called to order by President Kafer, of the Engineers' Club, and, on motion, Mr. Charles F. Scott, president of the Institute of Electrical Engineers, was elected chairman of the meeting and Prof. F. R. Hutton, secretary.

The chairman opened the meeting by reference to the questions which were to be considered, and called on Mr. Redding for a presentation of some of its legal aspects. After a very full and most harmonious discussion the meeting passed the accompanying resolutions unanimously. The secretary was directed to transmit a copy of the resolutions, as passed by the meeting, to each chairman of the constituent committee present, with a request that the latter should transmit the action of the meeting to the governing body of each respective organization. The conference then adjourned, subject to call of the chair.

Resolved, That this Joint Conference Committee recommend to the respective governing bodies represented at this conference that the following resolutions be brought before the several organizations to be acted on:

Resolved, That (insert name of organization) unite with (insert the names of the other four organizations), or any of them, for the purpose of accepting the sum of \$1,000,000 as a gift from Mr. Andrew Carnegie for the purpose of erecting suitable buildings for occupancy by various societies of engineers and the Engineers' Club on the sites secured for that purpose on the north side of Thirty-ninth street and south side of Fortieth

street, west of Fifth avenue, in the city of New York, in the State of New York; and

Resolved, further, That (insert name of organization) has a very high appreciation of this generous gift of Mr. Andrew Carnegie and this additional evidence of his recognition of the engineering profession and his deep interest in the welfare of the national societies of engineers and the Engineers' Club; and

Resolved, further, That a site on the north side of Thirty-ninth street shall be purchased and held by trustees, or otherwise shall be determined by the joint committee hereinafter mentioned for the American Society of Civil Engineers, the American Society of Mechanical Engineers, the American Institute of Electrical Engineers, and the American Institute of Mining Engineers, or by such of them as shall vote in favor of coming into this enterprise; and

Resolved, further, That a joint committee shall be created, to be composed of three members of each organization that shall unite in accepting said gift of \$1,000,000 from Mr. Andrew Carnegie; and that the governing body of (insert name of organization) shall elect three members of this organization to represent it on and be members of such joint committee, and that the governing body of (insert name of organization) shall have the right and power to remove any member of such joint committee who shall be elected by it and to elect any member of this organization to fill any vacancy that shall occur in such joint committee by reason of the death, resignation, refusal to act, or removal of any member who shall have been elected by

the governing body of this organization as a member of such joint committee; and

Resolved, further, That the character and internal arrangement of the building to be erected on the site on Thirty-ninth street shall be determined upon by the affirmative vote of at least two-thirds of all of such of the members of said joint committee as shall represent all of the organizations other than the Engineers' Club on such joint committee, and that the character and internal arrangement of the club building to be erected on the site on Fortieth street shall be determined upon by the affirmative vote of all of the three members of such joint committee who shall represent the Engineers' Club on such joint committee; and

Resolved, further, That said joint committee shall, by the affirmative vote of at least two-thirds of all the members thereof, select and employ an architect to prepare plans and specifications for the building to be erected on the site on Thirty-ninth street and for the club building to be erected on the site on Fortieth street, and shall also obtain proposals for the erection of both of such buildings, and shall have power to make and enter into such contract or contracts as shall be approved and authorized by the affirmative vote of at least two-thirds of all of the members of said joint committee for the erection of both of such buildings, and shall have charge of the erection of both of such buildings; and

Resolved, further, That said joint committee shall continue in existence until all of the purposes set forth in these resolutions shall have been fully accomplished.



High Speed, High Tension Locomotive and Motor Car on the Famous Berlin-Zossen Military Line.

High Power Electric Railways in Germany and Austria

By FRANK C. PERKINS

IN Italy and France heavy electric traction has advanced rapidly within the last three years. The Paris-Versailles electric line and the Austerlitz-Orsay line of the Compagnie de l'Ouest and the Compagnie d'Orleans are good examples of the electric traction work in France, while the Lecco-Chiavanna-Colico et Sondrio lines of the Compagnie des Chemins de Fer de l'Adriatique illustrate the work of this character in Italy.

In Germany and Austria great progress has been made in heavy electric traction work, both along the lines of elevated and underground railways, in Berlin and Budapest, and also in high-speed electric traction, as on the Gross-Lichterfeld line, the Berlin-Zossen military railway, the Duesseldorf-Crefeld railway, and in Vienna.

Direct current is used on the Budapest underground electric road; press-

ure being 400 volts. There are 14 motor cars of large size in operation, and six others are held in reserve. The normal speed is $12\frac{1}{2}$ miles per hour. During the first year over 4,000,000 passengers were carried, making a total of over 600,000 car miles.

This line, as well as the one between Duesseldorf and Crefeld, was installed and equipped by the firm of Siemens & Halske, of Berlin. The speed attained from Crefeld over the Neuss to Duesseldorf is about 25 miles an hour. The total length of the standard gauge road is $13\frac{3}{4}$ miles, and the greatest grade is 1:40, while the curve of least radius is $65\frac{2}{3}$ feet. The running time is from six to eight minutes, and within the city limits the speed must be reduced to $15\frac{1}{2}$ miles per hour. The overhead trolley wires are supplied with direct current at 600 volts pressure. The cars have a total length of $40\frac{2}{3}$ feet, and have a

seating capacity for 34 passengers and standing room for 16 passengers. The cars are divided into second and third-class compartments, and the freight and baggage cars are carried as trailers. The local cars are smaller and have two motor axles, with space for 16 seats and standing room for 14 passengers, while a trailer of the open type is provided, with a seating capacity for 24 passengers and standing room for 12. There are about 40 cars in operation of the two and four-motor axle passenger and freight type. A speed of $37\frac{1}{2}$ miles per hour has been attained on this line.

An electric three-phase line was equipped at Gross-Lichterfeld for high-speed, high-tension experiments in 1898. The road was one mile long, and the locomotive was equipped with two 60 horse-power three-phase motors, wound at first for 650 volts, and afterward changed to a 2,000-volt winding. The locomotive measured 21 feet between the buffers, and was designed to take the current from three overhead wires by means of three independent trolley contact arms. The greatest speed attained was $37\frac{1}{2}$ miles an hour, and, as certain results were obtained with this locomotive which seemed to promise better success on a better roadbed, a line was equipped between Berlin and Zossen on which a speed of 125 miles an hour was expected.

This line was $14\frac{1}{4}$ miles long, the shortest curve having a radius of 3,281 feet, while the highest grade was 1:184. The three-phase current used was supplied at a pressure of from 10,000 to 12,000 volts and a frequency of 45 periods per second.

The first motive power was supplied by a motor car of 8 tons draw-bar pull and a seating capacity for 50 persons. Each of the four axles were supplied with a three-phase motor, the normal

capacity being 250 horse power and the maximum 750 horse power. This high-speed three-phase motor car was $9\frac{2}{3}$ feet wide and $75\frac{1}{2}$ feet long, and weighed empty about 90 tons. The high-tension 10,000-volt three-phase current was conveyed into the car by contact devices mounted on posts at each end of the car, and was reduced in pressure to 1,150 volts within the car by step-down static transformers, which were kept cool by means of air which entered through shutters in the side of the car; this means also provided the necessary cooling for the rheostats. A speed of 93 miles per hour was easily obtained with this motor car on the Berlin-Zossen line, and a maximum of $99\frac{1}{2}$ miles per hour was reached, although it was not considered safe to operate at this speed with the heavy equipment of this motor car and the existing condition of the roadbed.

A new three-phase locomotive was then constructed by Siemens & Halske, somewhat similar in design to that used on the Gross-Lichterfeld experimental three-phase line, but much longer. This locomotive was $45\frac{1}{8}$ feet in length, and two of the axles were equipped with 150 horse-power motors having a maximum capacity of 420 horse power each, and provision was made for adding two other motors of equal capacity. The voltage used was 12,000, and the speed was 65 to 81 miles per hour. The motors were designed to operate at the full pressure of 12,000 volts without the use of step-down transformers on the locomotive, thus reducing the weight by 15 tons from the former motor car. This locomotive was tested at various speeds with the motor car and several freight cars as trailers. A speed of over 125 miles per hour is expected to be obtained without difficulty by means of three-phase electric traction.



With Our Foreign Consuls



Steel Factory in Spain.—Vice-Consul H. H. Hallatt, stationed at Madrid, Spain, writes as follows: In a plant recently established in Catalonia steel will be manufactured under conditions that have not yet been employed in Spain. The installation, in Badalona, of the first Spanish factory of this kind is now approaching completion; that is to say, a metallurgical establishment for the production of all classes of steel, although for the present the manufacture will be that of fine and molded (cast) steel exclusively. The process adopted is the same as that employed not only in England and in other countries in continental Europe, but also in North America. It involves obtaining the steel direct from the mineral; a new system of making armor plate, whereby the great problem of soldering has been solved; the making of plates of three, four, and more qualities of steel which are perfectly soldered together; the purification of the iron as it comes from the furnace; the manufacture of rolling-mill cylinders, etc. As has been said, the works for the present will only manufacture steel for tools and instruments, and all classes of molded (cast) pieces, from the largest to the smallest, and steel bars (rails). In this way the creation of a large number of industries that do not exist in Spain will be facilitated, as well as the development of others, the profits of which are small in relation to the large amount of work done, in consequence of their having to bring the principal material from abroad.

The works at Badalona are 12,000 square meters (14,352 square yards) in extent. There is a Siemens furnace of from 5 to 6 tons capacity, and one of 15 tons in course of construction; further, two furnaces for reheating, one large oven, a workshop for casting and forging, one steam hammer of large and one of smaller dimensions, shears and saws for working cold and hot iron, a metal-testing machine, cranes, lathes, and other machines necessary in industries of this kind—all run by steam engines fed by various boilers.

Swedish Brakes for Electric Motors.—Consul R. S. S. Bergh reports from Gothenburg:

Mr. Arthur Hultqvist, assistant engineer of the workshops of the electrical street railways of the city, has recently constructed a brake for electric motors, which consists of a small automatic reversing switch (omkopplare), which is fastened near the motor. On every machine is a pendant handle bearing the words "emergency brake" in red letters. If a workman should happen to be caught in the machinery, or any other accident should occur, the machinery can be quickly stopped by pulling the handle, which sets the brake in action. It is claimed that the machine can be stopped in this way within one-half or one-fourth rotation. It is expected that this brake will be found very useful in every establishment where electric motors are in use.

Russian Iron Industry.—W. R. Hol-
loway, Consul-General at St. Petersburg,
sends the following translation from the
"Messenger of Finance":

"The smelting of pig iron in Euro-
pean Russia during the last eighteen
months is shown below:

District.	Quantity.	
	Poods.	Tons.
Northern provinces...	2,254,913	36,665
Moscow Province.....	15,000,064	243,904
Ural provinces.....	74,260,224	1,207,483
Southern provinces....	136,401,608	2,217,912
Southwestern provinces.	14,179	230
Poland	28,643,447	465,747
Northwestern provinces	53,838	876

"The total for the first six months of
1901 was 85,678,063 poods (1,393,139
tons); for the second six months of 1901,
87,012,374 poods (1,414,833 tons); and
for the first six months of 1902, 83,937,-
836 poods (1,364,680 tons). Of these
figures, 82,134,009 poods (1,335,503
tons) for the first six months of 1901, 83,-
710,697 poods (1,358,172 tons) for the
second six months of 1901, and 80,985,-
764 poods (1,316,678 tons) for the first
six months of 1902 were yielded by pri-
vate works; and 3,544,054 poods (57,626
tons) for the first six months of 1901,
3,485,660 poods (56,661 tons) for the sec-
ond six months of 1901, and 2,952,172
poods (48,002 tons) for the first six
months of 1902 were yielded by the
works of the Government.

"These figures show that the decrease
in the yield of smelted pig iron, which
was observed in 1901, continued during
the first six months of 1902.

"The smelting of pig iron will grow in
time to such an extent that it will sur-
pass, it is hoped, the maximum yield of
1900. The yield in the Ural works is
without change. A decrease is observed
in the Moscow and southern and Polish
provinces. The works of the south-
western and northwestern provinces
show no yield at all.

"The production of iron and steel

goods in the south of Russia decreased
8½ per cent. from the same period of
1901. In the meantime the yield of the
following articles increased:

Description.	Total product.	
	Poods.	Tons.
Rails	9,407,625	152,969
Sheet iron and ridge iron plate	548,149	8,913
Iron wire.....	550,988	8,959
Tires	744,316	12,102
Iron pipes.....	643,193	10,460

"The production of rails in the Ural
works shows a decrease of 16 per cent.,
in comparison with the first six months
of 1901. The yield in assorted iron in-
creased by 17 per cent. and sheet iron de-
creased by 1-10th of 1 per cent.

"The total yield of worked iron and
steel, during the period reported, in-
creased 1 1-2 per cent. over the same
period of 1901.

Niagara Power Extension.—Consul
Harlan W. Brush, of Niagara Falls,
Ont., says:

The most important development of
last year in this consular district was the
enlarged production of electric power at
Niagara Falls. This has been in use at
Niagara Falls, N. Y., for several years
past, and the demand for this cheap and
constant power has been so urgent that
it has been impossible for the power
company to keep pace with it. The
original development of 50,000 horse
power at Niagara Falls, N. Y., was util-
ized some time ago, and the company
has been working night and day to
double the capacity of the plant, the
tunnel providing for a discharge of water
that would develop 100,000 horse power.
The second shaft has been completed,
the machinery has been installed, and
within a few months the full capacity of
the Niagara Falls, N. Y., plant will be
at the service of the Niagara frontier.

Realizing that the plant on the New
York side of the cataract would only suf-

fice for a short period, the power company commenced operations on the Canadian side of the river in August of 1901. The work has been pushed rapidly, and it is expected that by next August 50,000 horse power will be available. Already the demand is so great that recently the power company let a contract for extending the wheel pit at once, so as to develop 110,000 horse power instead of the 50,000 at first contemplated. The two companies are practically identical as to stockholders, the Canadian company being officially designated as the Canadian Niagara Power Company.

A radical departure from the installation on the New York side of the river is the utilization of dynamos of 10,000 horse power each, instead of the 5,000 units that were installed in the original power house. The 5,000 horse power dynamos were such mammoth experiments that it was feared they would prove impracticable, but now they are to be succeeded by dynamos of twice their capacity. Quite a marked saving is effected in the construction of a 10,000 horse power dynamo over two of 5,000 each.

British Inquiry for Castings.—Consul Marshal Halstead writes from Birmingham, England, that a manufacturer of anchors wishes to be put in communication with the makers of large steel castings and forgings. He wishes to hear from manufacturers who are able to take orders for and make early deliveries.

Traction Railroad in Honduras.—Alfred K. Moe, U. S. Consul at Tegucigalpa, Honduras, states that the Honduras National Congress has recently granted a concession to a resident of the city of Tegucigalpa to construct an automobile line or a traction road for the conveyance

of passengers and freight over the new wagon road between Tegucigalpa and the Bay of Fonseca. The line will be about eighty miles in length, and is designed, primarily, to connect the capital with the important port of Amapala, on the Pacific. The enterprise may interest manufacturers in the United States of traction supplies and electrical machinery, as well as our electrical and mechanical engineers. Mr. Daniel Fortin, the concessionary, will purchase all his supplies from the United States, and will soon visit our country to conclude contracts. The concession carries with it a monopoly of common carriage by means of electricity over the south coast road now in process of construction. The terms of the charter, briefly, are the following: The right is granted to establish and operate a service of automobiles or traction machines over the road between Tegucigalpa and San Lorenzo (Bay of Fonseca); to import, free of duties, the necessary material; to employ foreign laborers (except Chinese), who shall be exempt for five years from military service or municipal obligations. The grantee shall open his line to public service within one year after the completion of the wagon road. Transportation rates shall not, without Government consent, exceed 7 centavos (about 2.8 cents) per kilometer (0.62137 mile) for passengers nor 1.5 centavos (0.6 cent) per quintal (220.4 pounds) per kilometer for freight. Each passenger may carry free 22 kilograms (about 50 pounds) of baggage. Persons shipping products of the Republic for exportation shall obtain a 25 per cent. rebate. The enterprise shall maintain a regular service, except when interrupted by reason of the act of God or fortuitous circumstances; failing which, it shall be subject to a penalty, of from 100 to 300 pesos (\$40 to \$120), according to the gravity of the occasion. This con-

cession shall remain in force during twelve years; but the Government reserves the right to conclude it after six years, if it desires to operate the road, by paying the cost of the entire enterprise.

Profits of the German Electrical Industry in 1902.—In a statement sent to the Department of State by Consul T. J. Albert, of Brunswick, Consul Walter Schumann, of Mainz, and Consul H. W. Harris, of Mannheim, showing the dividends paid by some of the principal industrial undertakings in Germany for the year 1902 as compared with the preceding year, 5.92 per cent. is given as the average dividend paid in 1901 and 4.13 per cent. the average dividend paid in 1902. Mr. Albert states that it is generally believed that the turning point in the business depression in Germany has been reached, if not passed. Many corporations which had fallen into financial difficulties have been reorganized and put once more upon a stable foundation. American orders have been instrumental in reducing the surplus stock of the iron and steel companies. Building enterprises are being undertaken, and there is a demand for construction material. The number of applicants for labor at the Government employment office has decreased. The passage of the new tariff law has removed an element of uncertainty, and, with the new commercial treaties which are being negotiated, the impression prevails that business will once more assume a normal condition.

American Investments In Canada.—Consul-General John L. Bittinger, at Montreal, states that never in the history of Canada has the industrial outlook been as bright as it is to-day. The present year promises to be made memorable by the establishment of new and

immense enterprises and the extension of many existing ones. From Toronto comes the report that Thomas A. Edison has recently acquired several nickel mining properties in the vicinity of Sudbury. As nickel enters extensively into the manufacture of the Edison storage battery, Mr. Edison's acquisition will be readily understood. Several applications have recently been received by the Canadian Crown Lands Department, and it is surmised that Mr. Edison will construct reduction works in northern Ontario. At St. John, New Brunswick, a strong company has been formed to manufacture aluminum. James Robinson, M.P., is at the head, but the principal stockholders are American capitalists from New York. The capital is to be \$1,000,000, and the plant will comprise a factory at St. John and works at Grand Lake, which is the source of the raw material.

A New German Fire Extinguisher.—Richard Guenther, U. S. Consul at Frankfort, Germany, states that recently Mr. Max Eberhardt, an engineer of Munich, gave a demonstration of the effectiveness of a new preparation for extinguishing fires. The trials, it is reported, were successful. The preparation is a liquid of a milky color. The first experiment showed that the skin when painted with the liquid becomes insensible to heat. Rags saturated with petroleum can be burned upon the hand after it has been immersed in the liquid. Small fires can be extinguished with the hands, and with one pailful of the liquid a fire in a pit of tar was put out in one second. The tar, even after petroleum had been poured over it, could not be again ignited, as the liquid formed a thin, unmeltable crust which completely shut out oxygen. In the fourth experiment a pile of wood several yards in height and width was

ignited until it was in full blast. The fire was completely extinguished in 12 seconds with a little more than 12 gallons of the liquid. Small quantities of the preparation are sufficient for extinguishing purposes, so that the damages produced by water are avoided. The price of the liquid is about \$0.75 per quart. The trial took place in the presence of the chiefs of the fire department and representatives of the city council and board of public works.

The Trans-Andine Railway.—R. E. Mansfield, U. S. Consul at Valparaiso, Chile, has sent to the Department of State a synopsis of the Trans-Andine Railway bill which was recently passed by the Chilean Congress and promulgated by the President of the Republic. The bill provides for the construction of a railway over the Andes Mountains to connect Buenos Ayres on the Atlantic with Santiago and Valparaiso on the Pacific. This will be the first line to cross the continent of South America. This railway was projected twenty years ago, and since that time some sort of measure dealing with the question has been before each session of Congress; but each in its turn failed to pass one or the other branch of the law-making body until February 28th last, when the above-mentioned bill became a law. A railway extending from Buenos Ayres to the Cumbre of the Cordillera, at Uspallata Pass, to connect with the line from Valparaiso, is being constructed by the Argentine Government. Work on the new road is being pushed forward on both sides of the mountains, and prospects are bright for direct railway connections, within a few years, between the Atlantic and Pacific coasts, over the Andes, by a line extending through the heart of Chile and Argentina. This road will shorten the time between Europe

and Chile by six or eight days, as traffic is now via the Straits of Magellan. The railway from Buenos Ayres is completed as far as Puente del Inca, a short distance from the Cumbre, and the line in course of construction in Chile is completed as far as Salto del Saldado, also near the pass over the Andes, and during the summer months—November to April—traffic is carried on over the mountains, along the route of the proposed railway, by mule caravans. It requires only one day to make the trip between the railway terminals. The pass is crossed at an elevation of 13,000 feet above sea level; but the route as surveyed for the railway provides for a tunnel through the mountains, which will reduce the altitude of the highest point reached by the railroad to considerably below that of the Cumbre, where the mule transports cross.

A Fifteen-Million-Dollar Aqueduct for a Population of Fifty Thousand.—Consul Orlando H. Baker sends from Sydney, Australia, an interesting account of a remarkable piece of engineering work which has been recently completed for furnishing water to the Coolgardie and Kalgoorlie districts, Western Australia, where exist what are said to be the richest gold fields in the world. The total cost of the work is estimated to be not less than \$15,000,000, while the expense of operating and the interest on money borrowed is \$1,750,000 annually. Yet the aggregate population of the towns to be supplied with water—Kalgoorlie, Boulder and Southern Cross, all in the vicinity of the gold fields—is only 50,000. A dam 100 feet high has been built across the Helena River, in the Green Mount Range, about twenty-five miles northwest of Perth. The reservoir thus formed is seven miles long and will hold 4,000,000,000 gallons. It is proposed to deliver

from the reservoir to Kalgoorlie—328 miles away—5,000,000 gallons of fresh water daily. To send this water through the 328 miles of 30-inch pipe it was necessary to make a lift of 2,700 feet by means of eight pumping stations, the machinery for which cost \$1,500,000. The pipe is laid in the ground along the track of the railway, except in crossing the salt lakes on the route, where it is supported on bridges. Salt water has at all times been easily obtained, but the cost of condensation made fresh water too costly for abundant use. The aqueduct was undertaken that the rich gold fields of Coolgardie might be worked thoroughly, though a better supply of fresh water is also needed for domestic purposes. Although every house and tent is supplied with tanks to catch rain water, it has been necessary to practice great economy in its use. It is proposed to charge miners \$1.50 and others \$1.75 per 1,000 gallons, and, costly as this may appear, if the 50,000 people to be supplied should require the works to run at the fullest capacity it would hardly meet expenses. Some doubt has been expressed as to the sufficiency of the supply that can be gathered into the reservoir. It is said that although 26 inches of rain fell during 1902, there were but 726,000,000 gallons, instead of the 4,000,000,000 gallons that represent its full capacity, in December. However, it is generally hoped that the enterprise will meet with success, and an increased production of the precious metals will be made possible by an abundant supply of water. The boldness of this undertaking will be better comprehended when it is remembered that the total population of the State is but 194,890, and the total wealth only about \$215,000,000.

Electric Railway Project for Quebec.

—Felix S. S. Johnson, commercial

agent, at Stanbridge, Canada, states that a project for an extensive electric railway system through the south shore counties and eastern townships of Quebec is now in tangible form. It is understood that two main lines will be commenced this season, one to connect Montreal with St. John by way of Longueuil and Chambly and the other between Montreal and Valleyfield, closely following the river bank and taking in St. Lambert, Laprairie, Chateauguay, and Beauharnois. The roads are to be built with heavy tracks and in the most modern way, the cars being 50-odd feet in length, supplied with air brakes and motors capable of running at a speed of between 50 and 60 miles in straight stretches. There will also be parlor coaches for private parties.

It is claimed that this will be one of the largest electric railway systems in Canada, and will form part of vast plans now being mapped out for an electric road to connect New York with Montreal. It is understood that connections will be made with the important trolley roads in eastern New York—the Berkshires—and nearly a dozen systems in Vermont. Among the lines that are expected to serve as feeders for the projected main line, besides the Montreal and Southern Counties Railroad, are the Troy Traction Company, the Bennington Hoosick Railroad, the Hudson Valley line, the Troy and New England Company, and the Berkshire Street Railway Company, with about fifteen other corporations of less importance. The scheme is reported to be backed by capitalists from New York, Boston, and Chicago. The proposed main line from New York to the Canadian border would pass through much attractive scenery, the shore of Lake Champlain, which it will follow, being particularly beautiful. The Montreal and Southern Counties

Railway route will also have the scenic advantages of the Richelieu and St. Lawrence rivers. It will further enable the farmers all along the south shore to reach the markets of Montreal with their products. The company's intention is to make special arrangements for the carrying of all kinds of farm products between midnight and 6 a. m., thereby allowing the farmers to get their stuff into Montreal in good condition for the morning market.

Electric Auto-Car Service in Belgium.

—Consul-General Richard Guenther, Frankfort, Germany, writes that according to the *Journal de Bruxelles*, the International Sleeping Car Company has given orders for building an electric auto-car, which by August next will be running upon the Belgian State Railroad between Brussels and Ostend. The distance of 125 kilometers (78½ miles) will be covered; it is stated, in less than an hour. The car will carry 40 passengers.

Discovery of Asbestos in Siberia.—

Consul-General W. R. Holloway writes from St. Petersburg: The Official Messenger states that rich mines of asbestos

have been discovered in the Irkutsk district, 1½ miles from the Kitoi River, and a company has been organized to develop them. Preliminary tests are said to show that at a depth of 1 foot the asbestos is equal in quality to the Canadian, and superior to the Alpine product. The Kitoi River affords ample water power and cheap transportation to the railroad. The owners are receiving numerous requests from abroad for samples.

A new process for recovering the great quantities of tin lost in tinned-iron waste has been patented in Sweden. The material is placed in a vessel of iron or other stronger electropositive metal than tin, and this receptacle is filled with caustic alkali, a depolarizer—such as copper oxide—being also provided. An electric current is set up, the tin at the same time separating as alkali stannate. When the alkali has become saturated with stannate, a current of carbonic acid is injected into the solution, causing the tin to separate as stannic hydrate. This is treated with acid, and metallic tin is finally obtained from the resulting solution by electrolysis.—*Exchange*.



New Publications

The Tallerday Steel Pipe and Tank Company, of Waterloo, Iowa, have ready for distribution Catalogue No. 11, which is devoted mainly to galvanized steel tanks of and for all descriptions and purposes.

A. D. Granger & Co., Philadelphia, Pa., have issued a booklet on their Star safety water tube boilers for power, steam and hot water heating. Illustrations of the various types of boilers are shown, as well as detailed descriptions and data.

"Graphite," the Joseph Dixon Crucible Company's little publication, contains a number of bright little articles in its May issue. While it is devoted mainly to booming the Dixon Company's products, it also gives considerable space to other interesting items.

Two booklets, entitled, respectively, "Second-hand Machine Tools" and "A Modern Machine Shop Outfit," whose contents are indicated by their respective designations, are being sent out, on request, by the Garvin Machine Company, Spring and Varick streets, New York City.

Bulletin No. 4318, issued by the Publication Bureau of the General Electric Company, describes that company's CE motor. This is a direct-current stationary motor, and is built for slow speeds in sizes ranging from 2 to 15 horse power, and in moderate speeds from 3 to 20 horse power.

"Gold Dredging—The New Industrial," is the title of a booklet issued by Henry S. Bunting and Edward Van Asmus, 632, 110 La Salle street, Chicago, Ill. The booklet contains descriptions, opinions, illustrations, etc., regarding gold dredging, and is presented in a most attractive form.

Manhattan Electrical Supply Company, 32 Cortlandt street, New York City, have issued Catalogue No. 15, covering electric fans and accessories. Illustrations, descriptions and prices of the different types are given, embracing bracket, ceiling and desk fans for alternating and direct current, as well as battery use.

The Worcester (Mass.) Polytechnic Institute has issued its thirty-third annual catalogue. It contains, among other features, descriptions of the various courses, degrees granted, conditions of admissions, etc. The register of graduates shows the names of some of the most prominent engineers in the country.

The March number of the "Transactions of the American Institute of Electrical Engineers" contains the speeches delivered at the Library Dinner, the papers and discussions on train lighting by Messrs Scott, Bliss, Sperry, Farnsworth, and Shepardson; "The Arcophone," by R. A. L. Snyder; accessions to the Institute Library, etc.

The Brooklyn Edison for April contains a number of short and pithy articles

anent the advantages of the service rendered by the Edison Electric Illuminating Company of Brooklyn. Striking illustrations of a number of well-known restaurants in Brooklyn are shown, as well as other prominent places making use of the Edison service.

“Cranes of Many Different Kinds” is the suggestive title of a handsome booklet issued by Maris Bros., Philadelphia. It contains a short description of the Maris hand and electric traveling cranes manufactured by the above concern, the text being illuminated by a number of well-chosen illustrations. It is well worth writing for, not only for its attractive dress, but also for its meaty contents.

“Bulletins 90332 and 90331,” issued by the Stanley Instrument Company, Great Barrington, Mass., describe the Stanley recording wattmeters for alternating-current circuits and glass enclosed wattmeters, respectively. The different types of instruments are described in detail and are well illustrated. The instruments described are of the magnetic suspension type, the rotated parts being floated in air.

Rossiter, MacGovern & Co., Incorporated, the well-known dealers in second-hand machinery of all kinds, have, owing to increase in their business, removed to more commodious quarters in the Whitehall Building, 17 Battery Place, New York City, where they will be pleased to hear from and meet their friends and customers. A pleasant room has been set apart for the use and convenience of callers.

Catalogue No. 0223 of the C. W. Hunt Company, West New Brighton, Staten

Island, N. Y., is devoted to the electric storage battery locomotive manufactured by that company. These locomotives are particularly adapted for use in shops, foundries and manufactories where heavy material is to be moved on cars. Detailed descriptions, accompanied by suitable illustrations, are given of the construction, operation and maintenance of this type of industrial railways.

Purdue University, Lafayette, Ind., has published its annual catalogue, which is an imposing looking volume of some two hundred odd pages. It contains the names of the members of the faculty and instruction staff, origin and material equipment of the university, descriptions of the different courses of study, degrees, admission conditions, etc. The list of special lecturers contains names prominent in the engineering world, as well as men prominent in the public life of the country.

Automobile Catalogue, No. 5, issued by Charles E. Miller, 97-101 Reade St., New York City, contains list prices and illustrations of automobile, motor cycle and bicycle parts, fittings, sundries, tools, clothing, American and European novelties, etc. Mr. Miller, who conducts one of the leading automobile supply houses in the country, is the representative for the leading American manufacturers of parts, fittings and sundries. Copies of the above catalogue will be sent post-paid on application.

“Sparks From the Anvil,” a little magazine published bi-monthly by the Crucible Steel Company of America, Pittsburgh, contains in its May issue a number of well written articles dealing mainly with problems arising in connection with the working of steel. Its editor

is Mr. Albert L. Butler, and it is devoted to the better knowledge of steel and its treatment. Though modest in size it contains much matter of value and interest, being editorially and typographically a credit to its editor.

The American Electro-Therapeutic Association has issued a neat booklet containing information regarding its work. It gives a list of its officers, committees, fellows, honorary fellows and associate fellows, a historical sketch of the organization, and its constitution and by-laws. To those interested in the work of the above society, with a view to joining its ranks, copies of this booklet will be sent on applying to the secretary, Clarence Edward Skinner, M.D., LL.D., New Haven, Conn.

Catalogue No. 14 of the Chicago Fuse Wire and Manufacturing Company of Chicago treats of fuse wire, fuse strip and fuse links for electric lighting and power circuits; also fuse blocks and fuses for telegraph and telephone work, together with wire joints and sundry items, all of the company's manufacture. This list is illustrated and is neatly printed on green tinted paper with a gilt cover, and is a convenient size for an ordinary pigeon-hole. A copy of the above will be sent postpaid on request.

Number 1, of Volume VIII, of the "Journal of the Western Society of Engineers," contains "Copper Mining in Upper Michigan," by J. F. Jackson; "Diversity of Practice in General Railroad Engineering on American Railways," by A. A. Schenck; "The Administration of Streams Used in Irrigation," by Elwood Mead, as well as reports of the annual meeting, book notes, engineering directory, etc. An excel-

lent portrait of Ralph Modjeski, the newly-elected president of the society, is shown as a frontispiece.

The May number of the "Journal of the Franklin Institute" contains, among other interesting articles, "Notes on Recent Electrical and Scientific Developments Abroad," by William J. Hammer. A portion of this article, that describing the Valtellina 20,000-volt three-phase railway in Italy, was reprinted in the May number of THE ELECTRICAL AGE. "The Contributions of H. F. E. Lenz to the Science of Electromagnetism," by W. M. Stine, Ph.D., is concluded. "Notes and Comments," as usual, contains a number of interesting scientific bits.

Bulletin No. 76 of the Electric Storage Battery Company is entitled "The Application of Storage Batteries to Lighting and Power Plants," being a comprehensively written and illustrated dissertation on that subject. The illustrations show storage battery plants in use in the stations of the New York Edison Company and the Edison Electric Illuminating Company of Brooklyn. Inserted in the Bulletin is a clever reproduction of a newspaper account of the recent disabling of the Niagara power plant, stress being laid on the fact that chloride accumulators prevented the utter paralyzation of Buffalo's trolley service.

The General Electric Company's Publication Bureau have issued "Permanency of Transformer Insulation," a brochure treating of the method employed by the above company; "Flyer No. 2113," giving advice to customers regarding the placing of orders; Price List No. 5108 on fan motors; Supply Catalogue No. 7577 on parts of R-43, R-45 and R-47 con-

trollers; Catalogue and Price List No. 7576 on railroad line material; Bulletin No. 2317 on "Horizontal Cylinder Air Compressors," describing the electrically driven air compressors for railway work, manufactured by the General Electric Company.

The April number of the "Journal of the Western Society of Engineers" contains "Engineering of Illumination," by Van Rensselaer Lansing; "The Third Rail for High Speed Electric Service," by E. Gonzenbach; "Electric Railways," by H. M. Brinkerhoff; "Telephone Service," by S. J. Larned; "Development, Equipment, Etc., of Distributing System, Chicago Edison Company and Commonwealth Electric Company," by Ernest F. Smith; "Groundings of Alternate Current Systems," by George N. Eastman; besides which are the regular departments on books, engineering directory, etc.

The Fort Wayne Electric Works, of Fort Wayne, Indiana, have issued Instruction Book No. 3014, being devoted to the installation and operation of direct current series arc apparatus, "Wood" system; Bulletin No. 1042 on arc circuit cut-outs; Bulletin No. 1043, on single-phase generators, type W A L; Bulletin No. 1044, on belt-driven direct-current generators for lighting and power. While the above are devoted to describing the merits of Fort Wayne apparatus, they contain much matter of value to users and operators of electrical machinery. The booklet and bulletins are liberally illustrated and gotten up with much care and taste.

"The School of Mines Quarterly," No. 2, Volume XXIV, published at Columbia University, New York City, contains "On the Use of Influence Lines

In Graphic Statics," by Myron S. Falk; "The Morphology of Certain Organic Compounds," by Austin F. Rogers; "A Study of the Quantitative Determination of Antimony," by Lewis A. Youtz; "Upon the Structure of the Starch Molecule," by F. E. Hale; a brief biographical sketch of Prof. Ogden N. Rood; "The Geology of the Cerrillos Hills, New Mexico," by Douglas Wilson Johnson; "Abstracts—Notes on Recent Mineralogical Literature," by Alfred J. Moses and Lea McF. Luquer, and Book Reviews.

"The Permanent Protection of Iron and Steel," a lecture delivered before the New York Section of the American Chemical Society by Maximilian Toch, has been issued by the author in pamphlet form. In this paper the author discusses the question as to how long our high modern buildings, which are composed chiefly of steel and masonry, are going to last. He favors the method of applying cement mixtures on metal or masonry for their protection, being the originator of the idea of using a cement mixture that can be applied with a brush, which will set rapidly enough to prevent washing or dusting by rain or wind within an hour after its application, and set slowly enough after its initial setting to adhere firmly to its base. A number of photo-micrographs of the structure and physical properties of cement are shown, as well as samples of steel coated with various preparations of cement paint and subjected to different reagents and exposures.

The New York Edison Company's "Bulletin" for April has for its frontispiece an illustration, in tint, of the large ballroom at Delmonico's decorated with electric lights and flowers, making a striking and pleasing combination. The

letter-press consists of a number of short editorials on the advantages which the Edison service entails, a short sketch of the new City Prison, "A Ballad of the Signs of the Times," by Carolyn Wells; fan motors, electric power in the machine shop, wedding decorations, automatic lighting, etc., embellished with a number of well-chosen illustrations. Particularly interesting are the illustrations of a number of New York sky-scrapers which are furnished with light and power by the New York Edison Company. The poem by Miss Wells is cleverly illuminated. The scope of this publication is a large one, and its editors seem very much alive to their opportunities.

~

In a pamphlet entitled "The Fallacy of the Second Law of Thermo-dynamics and the Feasibility of Transmuting Terrestrial Heat Into Available Energy," the author, Mr. Jacob T. Wainwright, presents an addendum to his paper which he read on July 2, 1902, at the Pittsburgh meeting of the Physical Section of the American Association for the Advancement of Science on "Means for Transmuting Terrestrial Heat Into Available Energy." The author states that in order to prove the feasibility of utilizing common omnipresent terrestrial heat as a substitute for fuel it has been necessary to establish three new and important truths as advancements in the science of thermo-dynamics. First—

Refutation or destruction of the second law of thermo-dynamics. Second—Establishment of a new thermo-dynamic principle. Third—Applying this new principle so as to dispense with the external refrigerating medium which has heretofore been indispensable to the operation of all motive power heat engines.

A French process has for object the preliminary recovery of tin from waste tinned articles, and the subsequent coating of other articles, such as wire, with the re-covered metal. The electrolyte, consisting of ten parts of sulphuric acid of 66 degrees Bé, in 100 parts of water, and containing sufficient ammonium sulphate to prevent the liquid from attacking iron, copper, or brass, is placed in a lead-lined wooden vessel. The articles to be re-tinned are placed in a perforated rotating drum, the ends of which are lead lined. The articles in the drum form the anode, and the lead lining of the tank the cathode. A current is employed of from 60 to 80 amperes for every 200 liters of liquid, at a pressure of from 1 to 3 volts. The tin saturates the bath, while the excess is deposited upon the lead cathode in a pure crystalline pulverulent state. When all the tin has been thus recovered, the lead lining is connected up as the anode, and the article to be tinned is placed in the bath and connected up to form the cathode. When wire is to be coated, it is slowly drawn through the bath.—*Ex.*



CONTENTS

THE ELECTRICAL AGE

June, 1903.

Frontispiece.

The Heyland Asynchronous Motor, by <i>A. S. McAllister. Illustrated.....</i>	387
Electric Power for Lumber Mills, by <i>George E. Walsh.....</i>	392
The Curtis Steam Turbine, by <i>W. L. R. Emmet. Illustrated.....</i>	395
New Engineering Building for the University of Pennsylvania. <i>Illustrated.....</i>	405
Lessons in Steam Engineering—Second Paper, by <i>Charles J. Mason.....</i>	409
Alternating-Current Magnet Experiments, by <i>F. H. Doane. Illustrated.....</i>	413
American Institute of Electrical Engineers.....	415
Digest	416
A Twenty-Ton Switching Electric Storage Battery Locomotive. <i>Illustrated.....</i>	425
Current Engineering and Scientific Notes.....	429
Heating and Ventilation of Railroad and Other Shops.....	431
Editorial	435
High-Power Electric Railways in Germany and Austria, by <i>Frank C. Perkins. Illustrated.....</i>	437
With Our Foreign Consuls.....	439
New Publications.....	446

**The
Electrical
Age**

**20 Broad Street
New York**

Enclosed find \$1.00 for one year's
subscription to THE ELECTRICAL AGE,

beginning with..... number

NAME.....

ADDRESS

Should it be inconvenient to send post-office order or check, fold a one dollar bill in a sheet of writing paper with your name and address and mail it in the ordinary way. Put your name and address on the back of envelope. If you do this we will be responsible and send you the Magazine at once should letter get lost in the mails.

STEEL BUILDINGS,
SHEET IRON WORK,
GALVANIZED IRON WORK,
SHEET COPPER WORK.

ORNAMENTAL CAST and
WROUGHT IRON WORK
STAIRWAYS, BALCONIES and
ROOFS, ELEVATORS,
GAS HOLDERS and TANKS

DESIGN and CONSTRUCT Gas Plants,
Cane and Beet Sugar Plants

BARTLETT, HAYWARD & Co.

BALTIMORE, MD.

Field-Clay Conduits

ALL TYPES

Multiple—Conduits—Single



Large
Factories
In East and West

Moderate
Prices

Prompt
Deliveries

Write or telephone your
requirements and we
will submit samples
and prices.

C. J. FIELD

29 Broadway,

New York.

Telephone
5928 Broad

Standard Wiring

For Electric Light
and Power

By H. C. Cushing, Jr., A. I. E. E.
Electrical Engineer and Inspector

Adopted by Cornell University, Stanford University and other Technical Colleges, and Schools, and by over 47,000 Electrical Engineers, Central Station Managers and Wiremen. It contains all the necessary Tables, Rules, Formulas and Illustrations, and it is the only book on Wiring and Construction kept strictly up to date.

FLEXIBLE LEATHER COVER
(Pocket Size), \$1, Post-paid.

THE ELECTRICAL AGE

20 Broad Street, N. Y.

CLOCK WORK

DEVICES, SMALL GEARING
SPRING MOTORS

And Metal Specialties.

Send Samples or Sketches for Estimates.

Reeves Mfg. Co., New Haven, Conn.

FOR SALE

One Complete Set of Books and Testing Instruments

that comes with the \$70.00 Electrical Engineering Course of the International Correspondence Schools of Scranton, Pa.

If interested please write at once to

PERCIE McCRAY, Box 124, Corry, Pa.

Edison Primary Batteries

FORMERLY KNOWN AS EDISON-LALANDE

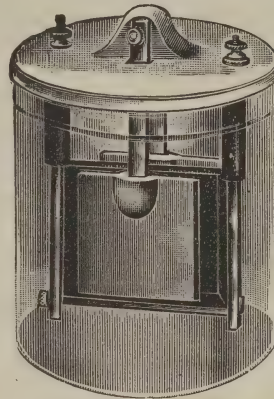

For GAS ENGINES
SLOT MACHINES
AUTOMOBILES
RAILROAD SIGNALS
CROSSING BELLS
SMALL MOTORS
ETC.

CONSTANT CURRENT
NO LOCAL ACTION
WILL NOT FREEZE
LIQUID TIGHT
CELLS FOR
PORTABLE WORK

FULL DESCRIPTION IN BOOKLET No. 10

Edison Manufacturing Company

FACTORY

NEW YORK OFFICE

ORANGE, NEW JERSEY, U. S. A.

83 CHAMBERS STREET

CHICAGO OFFICE

304 WABASH AVENUE

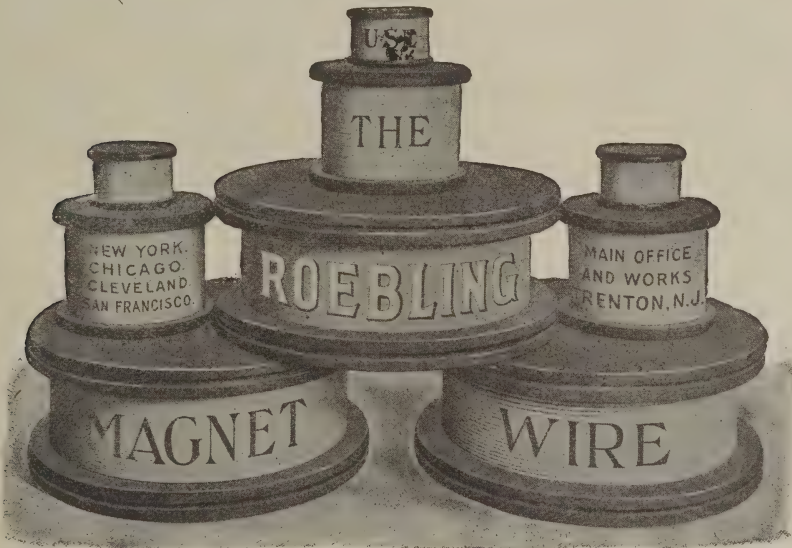

JOHN A. ROEBLING'S SONS CO.

Manufacturers
of

Iron, Steel and Copper Wire Rope and Wire

OF EVERY DESCRIPTION

TRENTON, N. J.

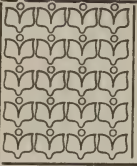

Best Engine for Operating Electric Light Dynamos

OUR Engines are peculiarly simple. They have no dangerous features, operate on common kerosene and are practically noiseless and odorless.

The International Engine

requires but one gallon of oil per horse power for Ten Hours' operation. *No other expense for operation, maintenance and equipment, except for a little lubricating (cylinder) oil.*

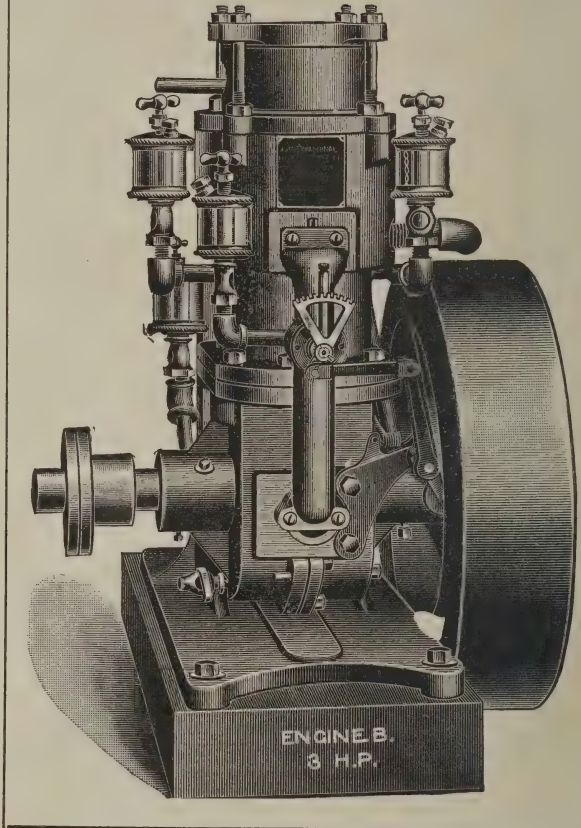

The International

Is SIMPLE, DURABLE, RELIABLE
and MORE ECONOMICAL than any other

WRITE FOR CATALOGUE AND FULL PARTICULARS TO THE MANUFACTURERS

**The International Power Vehicle
Company, 757 Pacific St., STAMFORD, CONN.**

The United Engineering & Contracting Co.

13-21 PARK ROW., NEW YORK.

Contractors for

Complete **ELECTRIC LIGHT & POWER PLANTS** ~ or ~ any part thereof. ~ ~ ~ ~ ~

TELEPHONE & SIGNAL Systems

Electric Wiring . . .

Contracts executed in any part of the United States. Correspondence from Architects and Engineers invited. Estimates furnished promptly.

Can I Become An Electrical Engineer?



YES, you can. We teach **ELECTRICAL ENGINEERING** at your home BY MAIL at a cost within the reach of anyone. **No matter where you live**, if you can read and write, we guarantee to teach you thoroughly. Our institute is endorsed by **Thomas A. Edison** and every prominent electrical engineer.

I consider the Electrical Engineer Institute conducted by Messrs. Wetzel and Martin to be of great value to those who desire an electrical education.
Thomas A. Edison

We teach also:

Mechanical Engineering, Steam Engineering, Mechanical Drawing, Telephony, Telegraphy, Electric Lighting, Electric Railways, Electric Motorman's Course, Short Electrical Course, Dynamo Tender's Course, Elementary Mathematics, etc., by mail.

Thousands are successful and gaining better positions and salaries studying at home by our correspondence system. Write for our **FREE ILLUSTRATED BOOK**, "Can I Become an Electrical Engineer?"

The Electrical Engineer Institute of Correspondence Instruction, Dept. JR,

240-242 WEST 23d STREET, NEW YORK.

Jos. Wetzel, M.E., E.E., Pres.
T. Commerford Martin, Vice-Pres.



PATENTS

Quickly secured **OUR FEE DUE WHEN PATENT OBTAINED.** Send model, sketch or photo, with description for free report as to patentability. **48-PAGE HAND-BOOK FREE.** Contains references and full information. **WRITE FOR COPY OF OUR SPECIAL OFFER.** It is the most liberal proposition ever made by a patent attorney, and **EVERY INVENTOR SHOULD READ IT** before applying for patent. Address:

H. B. WILLSON & CO.
PATENT LAWYERS,
Le Droit Bldg., WASHINGTON, D. C.

Electric Lighting Specifications for the Use of Engineers and Architects

By **A. E. MERRILL.**

12mo; cloth.

\$1.50 postpaid.

THE ELECTRICAL AGE, 20 Broad Street, New York City.

THE BABCOCK & WILCOX Co.
 85 LIBERTY ST.
 NEW YORK
 CABLE ADDRESS
 NEW YORK
 "GLOVEBOXES"
 ALL FOREIGN OFFICES
 "BABCOCK"

WATER TUBE **STEAM** **BOILERS**

SEND FOR OUR BOOK "STEAM"

BOSTON
 35 FEDERAL ST.
PHILADELPHIA
 NORTH AMERICAN BLDG.
SAN FRANCISCO
 32 FIRST ST.

BRANCH OFFICES
CHICAGO NEW ORLEANS
 MARQUETTE BLDG. 339 CARONDELET ST.
PITTSBURGH
 EMPIRE BLDG.

ATLANTA, GA.
 EQUITABLE BLDG.
MEXICO CITY
 CIUDAD DE MEXICO BLDG. 7 AVENIDA JUAREZ
HAVANA, CUBA
 116 1/2 CALLE DE LA HAVANA

Specify
LUNKENHEIMER
 Re grinding Valves
 "Last as long as the pipe"

General Electric Company's

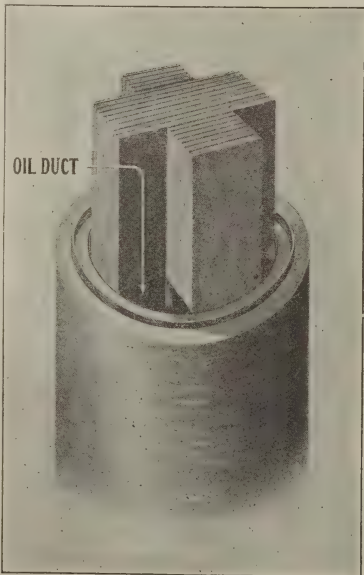

TYPE "H" TRANSFORMERS
CORE TYPE—OIL COOLED

EXPERT designers, selected materials, and the most approved methods of manufacture—and consequent durability and high efficiency—have made Type "H" Transformers famous in all respects.

Write nearest Sales Office for Pamphlet 9114.

General Offices:
SCHENECTADY, N. Y.

New York Office : 44 Broad St.

Sales Offices in All Large Cities.

THE STRONGEST LIGHT

of an incandescent lamp comes through the tip end—the end opposite the base.

THE "ANGULATOR"

fits into the socket of any standard Photometer and enables you to test your own lamps.

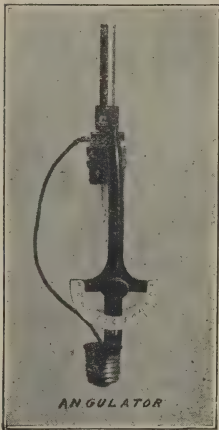

Fig. 1.

By the aid of this device the horizontal candle power can be determined (see Fig. 1), and the lamp can be turned so that its light can be measured at any angle (see Fig. 2).

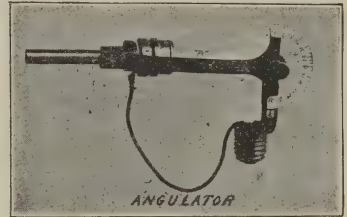
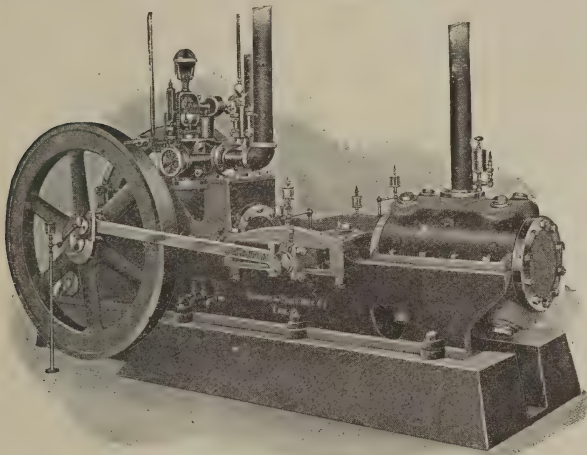

Fig. 2.

Price, \$2.50.

The **SHELBY ELECTRIC CO.**, Shelby, Ohio.



Air Compressors

COMPLETE LINE

PNEUMATIC TOOLS

and **AIR HOISTS**

**E. W. Irwin Machinery
and Supply Co.**

114-118 LIBERTY STREET

New York City

OUTLINES OF ELECTRO-CHEMISTRY

WITH TABLES AND DIAGRAMS

By **HARRY C. JONES.**

Price \$1.50, postpaid.

THE ELECTRICAL AGE,

20 BROAD STREET,
NEW YORK.

A SPECIAL OFFER TO OUR SUBSCRIBERS

Every electrical and mechanical engineer wants and needs a library of technical books, and we have arranged so that our subscribers can secure one without cost. Every one of our subscribers undoubtedly has one or more friends or acquaintances who would be glad to subscribe to "The Electrical Age" if it was called to their attention. We want you to do this for us, and to secure their subscription if possible; and, as a remuneration for this service, we are offering a series of standard works pertaining to electrical and mechanical matters which should be in every technical man's library. Several of these works we will send free if you will secure one new subscriber; others, more expensive, require a larger number. For convenience we have arranged these into groups.



If you send us \$1.00 and the name of one new subscriber to The Electrical Age we will send you, postpaid, any one of the following books:

- | | |
|---|--|
| <p>"A. B. C. of the Telephone," by J. E. Homans, A. M. This book is arranged in 28 chapters, dividing the subject into definite departments which are thoroughly discussed. Book contains 352 Pages, 269 Illustrations. Price, \$1.00 postpaid.</p> <p>"Algebra Made Easy," by Edwin J. Houston, Ph. D., and A. E. Kennelly, Sc. D. 101 Pages. 5 Illustrations. Price, 75 Cents postpaid.</p> <p>"Diagrams of Electrical Connections," with explanatory text. 32 Pages, 8½ x 11½ inches. Price, 50 Cents postpaid.</p> | <p>"Standard Wiring for Electric Light and Power," by H. C. Cushing, Jr., A. I. E. E. Adopted by Cornell University, Stanford University and other Technical Colleges and Schools, and by over 47,000 Electrical Engineers, Central Station Managers and Wiremen. It contains all the necessary Tables, Rules, Formulae and Illustrations, and it is the only book on Wiring and Construction kept strictly up to date. Flexible leather cover (pocket size). Price, \$1.00 postpaid.</p> |
|---|--|

For \$2.00 and the names of two new subscribers, or \$1.00 and one new subscriber to The Electrical Age and 25 Cents additional (\$1.25), we will send you, postpaid, any one of the following books:

"Practical Management of Dynamos and Motors," by Prof. F. B. Crocker and Dr. S. S. Wheeler, with a special chapter by H. O. Foster. 206 Pages. 99 Illustrations. For Station Superintendents and Working Engineers. Cloth. Price, \$1.00 postpaid.

"Incandescent Wiring Hand-Book," by Lieut. F. B. Badt. Profusely illustrated. Cloth. Price, \$1.00 postpaid.

"The Electric Motor," by Edwin J. Houston, Ph. D., and A. E. Kennelly, Sc. D. This volume contains a discussion of the principles underlying the construction and operation of continuous and alternating current motors, noticing in the latter case both the synchronous and induction type of apparatus. Cloth. 377 Pages. 122 Illustrations. Price, \$1.00 postpaid.

"Electrical Measurements and other Advanced Primers of Electricity," by Edwin J. Houston, Ph. D. This volume is devoted to the measurement and practical applications of the electric current. The different sources of electricity are taken up in turn, the apparatus described with reference to commercial forms and the different systems of distribution explained. The sections on alternating currents will be found a useful introduction to a branch which is daily assuming larger proportions, and which is here treated without the use of mathematics. Cloth. 429 Pages. 169 Illustrations. Price, \$1.00 postpaid.

For \$2.00 and the names of two new subscribers, or \$1.00 and the name of one new subscriber to The Electrical Age and 75 Cents additional (\$1.75), we will send, postpaid, any of the following books:

"Alternating Current of Electricity and the Theory of Transformers," by Alfred Still, with numerous diagrams. Cloth. 184 Pages. Price, \$1.50 postpaid.

"Safety Valves: Their History, Invention and Calculation," by William B. Le Van. This work includes the more recent examples of Weighted and Spring-loaded Valves, also showing the effect of Atmospheric Pressure on Safety-Valve Disks; showing the curious phenomenon of balls being sustained by an inclined current of air, Vacuum Valves and their importance in heating and boiling. Illustrated by 69 Engravings, bound in pocket-book form. Price, \$1.50 postpaid.

"New Catechism of Electricity," by N. Hawkins. The work contains chapters on The Dynamo; Conductors and Non-Conductors; The Care and Management of the Dynamo and Motor; Electric Lighting; Wiring; The Rules and Requirements of the National Board of Underwriters in Full; Electrical Measurements; Storage Batteries; Care and Management of the Street Car Motor; Electro Plating; The Telephone and Telegraph; The Electric Elevator, etc., etc. Contains 550 Pages and 300 Diagrams and Illustrations. Bound in heavy red leather. Size, 4½ x 6½ inches. Price, \$2.00 postpaid.

If you wish any of the books mentioned above and cannot secure the number of new subscribers necessary, we will mail the books on receipt of price, postpaid.

The Electrical Age,
20 Broad Street, New York.

Get prompt attention by mentioning *The Electrical Age*

THE STANDARD FOR RUBBER INSULATION

**OKONITE
WIRES
MANSON
TAPE**

1889 Paris Exposition Medal
1893 World's Fair Medal

WILLARD L. CANDEE, } Managers.
H. DURANT CHEEVER, }



TRADE MARK.

SOLE MANUFACTURERS

**OKONITE
TAPE
CANDEE
WEATHER-PROOF
WIRES**

GEO. T. MANSON, General Superintendent
W. H. HODGINS, Secretary

253 BROADWAY THE OKONITE CO., LTD. NEW YORK CITY

WESTON

Standard Portable Direct-Reading
Voltmeters and Wattmeters

For Alternating and Direct Current Circuits

Are the only Standard Portable Instruments of the type deserving this name.



Send for our
Catalogue of
Portable
Instruments.

Weston Electrical Instrument Co.
Waverly Park, Newark, N. J.

BERLIN: European Weston Electrical Instrument
Co., Ritterstrasse, No. 89.

LONDON: Elliott Bros., Century Works, Lewisham.

PARIS, FRANCE: E. H. Cadiot, 12 Rue St. Georges.

NEW YORK OFFICE: 74 Cortlandt St.

Christie Iron Works

519 to 527 East 18th Street

New York

Marine & Stationary Engines

Refrigerating Machines, Pumps, Presses,
Etc., Repaired and Rebuilt. Cylinders
Rebored in Position and with hard char-
coal Iron Liners. Also Bearings, Fly-
wheels, Housings, Sterntubes, Cranks, Dy-
namo-fields, Valve-Chambers, Hydraulic-
Cylinders, etc. Christie's Patent High and
Low Pressure Duplex Cylinder Packing
Boring Machinery of Every Description.

Telephone: 39-18th Street.

ROSSITER, MACGOVERN & Co.

(INCORPORATED)

WHITEHALL BUILDING, No. 17, BATTERY PLACE, NEW YORK CITY.

**Engines, Boilers, Dynamos, Motors, Street Cars, Street Car Motors and
Equipment of all Standard Types.**

Branch Offices: BOSTON, MASS.; ST. LOUIS, MO.

Factory and Repair Shop: JERSEY CITY, N. J.

BROWN BROTHERS & CO.

PHILADELPHIA
4th and Chestnut Sts.

NEW YORK
59 Wall Street.

BOSTON
50 State St.

and **ALEX. BROWN & SONS**, Baltimore and Calvert Sts., Baltimore

ALL CONNECTED BY PRIVATE WIRE.

Members of the New York, Philadelphia and Baltimore Stock Exchanges.

Execute Orders on Commission for Purchase and Sale of Stocks, Bonds, and all Investment Securities, Bills of Exchange Bought and Sold.

Commercial Letters of Credit, Travelers' Letters of Credit, International Cheques issued available in all parts of the World. Collections made on all points; Telegraphic Transfers of Money made between this Country and Europe. Deposit Accounts of American Banks, Bankers, Firms and Individuals received upon favorable terms.

Brown, Shipley & Co., Founders' Court, Lothbury, E. C., London.

Guaranty Trust Co. of New York

Mutual Life Building

NASSAU, CORNER CEDAR STREET

LONDON OFFICES: 33 LOMBARD ST., E. C.; 60 ST. JAMES ST., S. W.

Fiscal Agents of the
United States Government.

Manila, Philippine Islands,
Hong Kong, China.

Depository of the Government of the
Philippine Islands, Manila.

Capital, \$2,000,000, Surplus and Undivided Profits, \$5,369,000.

INTEREST ALLOWED ON DEPOSITS SUBJECT TO CHEQUE OR ON CERTIFICATE.

Acts as Trustee for Corporations, Firms and Individuals; and as Guardian, Executor and Administrator; takes entire charge of Real and Personal Estates; carefully selected securities offered for investment.

TRAVELERS' LETTERS OF CREDIT AVAILABLE IN ALL PARTS OF THE WORLD.
COMMERCIAL LETTERS OF CREDIT ISSUED.

Drafts on all parts of Great Britain, France, Germany, China and Philippines bought and sold.

WALTER G. OAKMAN, President.

GEORGE R. TURNBULL, 2d Vice-President.

WM. C. EDWARDS, Treasurer.

E. C. HEBBARD, Secretary.

ADRIAN ISELIN, JR., Vice-President.

HENRY A. MURRAY, 3d Vice-President.

JOHN GAULT, Manager Foreign Department.

F. C. HARRIMAN, Assistant Treasurer.

R. C. NEWTON, Trust Officer.

DIRECTORS:

George F. Baker,
George S. Bowdoin,
August Belmont,
Frederic Cromwell,
Walter R. Gillette,

G. G. Haven,
Edwin Hawley,
E. H. Harriman,
R. Somers Hayes,
Charles R. Henderson,

Adrian Iselin, Jr.,
Augustus D. Juilliard,
James N. Jarvie,
Richard A. McCurdy,
Levi P. Morton,
Harry Payne Whitney.

Alexander E. Orr,
Walter G. Oakman,
Henry H. Rogers,
H. McK. Twombly,
Frederick W. Vanderbilt,

London Committee:

ARTHUR J. FRASER, Chairman; DONALD C. HALDEMAN.

WM. A. ROSENBAUM

PATENT ATTORNEY

140 Nassau St. New York City

(Formerly in the Times Building)

Edward B. Weed

George R. Leslie

WEED & LESLIE

Investment Securities

Telephone 4344 Broad
Unlisted Securities a Specialty.

55 Wall Street
New York

A. A. de BONNEVILLE

Patent Attorney & Mechanical Expert

141 BROADWAY, NEW YORK

Washington Life Building

J. G. WHITE & COMPANY,

Incorporated

ENGINEERS, CONTRACTORS

29 BROADWAY NEW YORK, N. Y.

London Correspondents: J. G. White & Co., Ltd.
22a College Hill, Cannon St.

WE INVITE YOUR DEPOSIT ACCOUNT

United States Mortgage and Trust Company

55 CEDAR STREET, NEW YORK
WEST END OFFICE, 73D STREET AND BROADWAY

CAPITAL AND SURPLUS
FIVE MILLIONS

Issues Travelers' Letters of Credit and Foreign Drafts

**THE AUDIT COMPANY
OF NEW YORK**

—
Examinations
Appraisals
Audits

Investigations for Financing and Under-
writing and for Re-organization
Committees

**Mutual Life Building, 43 Cedar St.
NEW YORK**

N. Y. Life Bldg.
CHICAGO

Arcade Bldg.
PHILADELPHIA

The American De Forest Wireless Telegraph Co.

Is prepared to furnish estimates for the equipment of yachts and steamers, also the establishing of PRIVATE wireless telegraph service between cities or other points.

The De Forest system has been accepted by the United States Navy after many severe competitive tests. The following is the report of the Chief Signal Officer, U. S. A. War Department Signal Office:

Washington, October 1, 1902.
SIR:—In connection with the army and navy manoeuvres it was deemed advisable to test all available systems—namely, the De Forest, the Fessenden and the Marconi. The De Forest system gave very good results, and it is believed that this system of transmission, utilizing an alternating current with step-up transformers in oil insulation, is theoretically **the best**, as well as giving the **most promising practical results**.
The Secretary of War, Washington, D. C. A. W. GREELY, Brigadier General, Chief Signal Officer of the Army.

Stations have already been erected by the Company at 17 State Street, New York City; Coney Island, Staten Island, Fort Mansfield, Point Judith, R. I.; Block Island, R. I.; Cape Hatteras, Yonkers, N. Y.; Newburg, N. Y.; Poughkeepsie, N. Y.; S. S. "Warden" (N. Y. Harbor); Fort San Cristobal, Porto Rico.

DE FOREST WIRELESS AUTO NO. 1. (Stationed before No. 25 Broad St., New York City, from which curb market quotations are transmitted by wireless to the brokers' offices.)

The company has a capital of \$5,000,000, \$500,000 of which is 7 per cent. preferred, cumulative and participating stock, and \$4,500,000 common stock. Par value \$10 per share. For complete information regarding equipment or stock, address

**American De Forest Wireless Telegraph Company,
100 Broadway, NEW YORK.**

COMMERCIAL TRUST COMPANY OF NEW JERSEY

15, 17, 19 and 21 Exchange Place, Jersey City, N. J.

Capital, Surplus and Profits, \$2,800,000

**SAFE DEPOSIT VAULTS OF THE BEST MODERN CONSTRUCTION AT
MOST ACCESSIBLE POINT FROM NEW YORK,
BEING ADJACENT TO PENNSYLVANIA RAILROAD CO.'S FERRIES
BOXES FROM \$5 TO \$500 PER ANNUM**

Transacts a general banking business. Executes all Trusts

OFFICERS

**John W. Hardenbergh, President
George W. Young, Vice-President**

**Robert S. Ross, Vice-President
Oscar L. Gubelman, Sec. and Treas.**

DIRECTORS

Walter E. Ammon
August Belmont
C. Ledyard Blair
Frederick G. Bourne
William Brinkerhoff
John D. Carscallen
Frederick Cromwell
C. C. Cuyler
Jacob J. Detwiller
Charles D. Dickey

Oscar L. Gubelman
John W. Hardenbergh
George G. Haven
James N. Jarvie
William B. Jenkins
C. H. Kelsey
Gustav E. Kissel
Henry Lembeck
James A. MacDonald
Richard A. McCurdy
Robert H. McCurdy

Allen L. McDermott
James G. Morgan
Robert S. Ross
Edwin A. Stevens
Eben B. Thomas
Myles Tjerner
James Timpson
Cornelius Vanderbilt
John J. Voorhees
George W. Young

"THE HOW AND WHY OF ELECTRICITY"

By CHARLES TRIPLER CHILD

THE author of this book was one of the ablest and most easily understood writers on electrical subjects.

The "How and Why of Electricity" treats of the properties of electricity, of how it is generated, handled, controlled, measured and set to work, and explains the operation of electrical apparatus.

It is a book the business man, the professional man, the architect, the contractor, the student, the electrician, in fact all persons in professional or business life, can read with interest and profit.

It brings you up to date in knowledge of electrical achievements and electrical conditions. **Price \$1.00, post paid**

Address Electrical Age

Book Department

20 Broad Street, New York

N. B.—We will send this book, post-paid, to any of our present subscribers who send us \$2.00 and the names of two new subscribers. ❧ ❧ ❧ ❧





UNIVERSITY OF ILLINOIS-URBANA



3 0112 098050187