



This is a digital copy of a book that was preserved for generations on library shelves before it was carefully scanned by Google as part of a project to make the world's books discoverable online.

It has survived long enough for the copyright to expire and the book to enter the public domain. A public domain book is one that was never subject to copyright or whose legal copyright term has expired. Whether a book is in the public domain may vary country to country. Public domain books are our gateways to the past, representing a wealth of history, culture and knowledge that's often difficult to discover.

Marks, notations and other marginalia present in the original volume will appear in this file - a reminder of this book's long journey from the publisher to a library and finally to you.

### **Usage guidelines**

Google is proud to partner with libraries to digitize public domain materials and make them widely accessible. Public domain books belong to the public and we are merely their custodians. Nevertheless, this work is expensive, so in order to keep providing this resource, we have taken steps to prevent abuse by commercial parties, including placing technical restrictions on automated querying.

We also ask that you:

- + *Make non-commercial use of the files* We designed Google Book Search for use by individuals, and we request that you use these files for personal, non-commercial purposes.
- + *Refrain from automated querying* Do not send automated queries of any sort to Google's system: If you are conducting research on machine translation, optical character recognition or other areas where access to a large amount of text is helpful, please contact us. We encourage the use of public domain materials for these purposes and may be able to help.
- + *Maintain attribution* The Google "watermark" you see on each file is essential for informing people about this project and helping them find additional materials through Google Book Search. Please do not remove it.
- + *Keep it legal* Whatever your use, remember that you are responsible for ensuring that what you are doing is legal. Do not assume that just because we believe a book is in the public domain for users in the United States, that the work is also in the public domain for users in other countries. Whether a book is still in copyright varies from country to country, and we can't offer guidance on whether any specific use of any specific book is allowed. Please do not assume that a book's appearance in Google Book Search means it can be used in any manner anywhere in the world. Copyright infringement liability can be quite severe.

### **About Google Book Search**

Google's mission is to organize the world's information and to make it universally accessible and useful. Google Book Search helps readers discover the world's books while helping authors and publishers reach new audiences. You can search through the full text of this book on the web at <http://books.google.com/>

A

756,813

DUPL

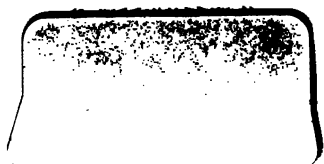

1870  
1871  
1872  
1873  
1874  
1875  
1876  
1877  
1878  
1879  
1880  
1881  
1882  
1883  
1884  
1885  
1886  
1887  
1888  
1889  
1890  
1891  
1892  
1893  
1894  
1895  
1896  
1897  
1898  
1899  
1900

1870

1871

1872

1873

1874

1875

1876

1877

1878

+

1879

1880







# ELECTRICITY

## EXPERIMENTALLY AND PRACTICALLY APPLIED

*A BOOK FOR THE BEGINNER AND FOR  
THE PRACTICAL MAN*

PRINCIPLES, EXPERIMENTS, PRACTICAL  
APPLICATIONS AND PROBLEMS

BY

SYDNEY WHITMORE ASHE, B.S., E.E.

Author of "Electric Railways"; Formerly Instructor in Physics  
and Electrical Engineering, Polytechnic Institute of Brooklyn



NEW YORK  
D. VAN NOSTRAND COMPANY  
23 MURRAY AND 27 WARREN STREETS  
1910



**ENGIN. LIBRARY**

TK

146

.A32

COPYRIGHT, 1910, BY  
D. VAN NOSTRAND COMPANY.

**Dedicated**

TO

MY WIFE

HATTIE BELL LIPPENCOTT ASHE

IN APPRECIATION OF HER SYMPATHY WHICH MADE THE

PREPARATION OF THIS BOOK A PLEASURE

AND NOT A TASK



## PREFACE

ALTHOUGH a number of excellent works on practical electrical engineering are already in use, the author believes there is a place for a volume that will present the subject from an experimental standpoint. For many years the author has taught the subject of electrical engineering by means of experimental lectures and laboratory work to large numbers of practical men. Since these students have often lacked mathematical training, it has been necessary to explain the subject-matter in a very simple way, showing, wherever possible, its practical features. The same method of presentation has been used in this text, and it is hoped that a much larger audience may thus be reached and benefited. This volume is particularly adapted to courses of instruction given to those engaged in actual electrical work; it should likewise prove useful as a text for high schools and for college laboratory courses.

Owing to the manner in which the experiments are arranged in the text and the detailed descriptions given this volume should prove helpful to the self-taught individual.

The author has assumed at the outset, as in his lectures, that the reader is familiar with certain practical terms. This assumption is justifiable, since most beginners, if at all interested in their subject, are likely to have acquired a knowledge of general facts before they have begun the systematic study of the subject. Practical men in particular have a much greater knowledge of funda-

mental principles than they are ordinarily given credit for. Later in the text such terms are defined in detail. The explanations of experiments usually give the details for their performance before an audience, as experiments thus performed are much more difficult than those made in a laboratory. If any experiment is to be performed by a single individual, however, as in a laboratory, the author has trusted to the reader's originality to omit superfluous apparatus.

In looking over the experiments it may be noted that a number of them are modifications of standard experiments such as those on induction developed by Faraday. There is, however, a large number of new experiments given. These experiments were developed in connection with educational courses given to the employees of the Brooklyn Rapid Transit Company, the Edison Illuminating Company of Brooklyn, the New York Edison Company, the Boston Edison Company, and the Consolidated Gas Electric Light and Power Company of Baltimore.

The author's thanks are due to Mr. S. R. Keyes, of the Boston Edison Company, and to Dr. Frank W. Chandler at the Polytechnic Institute of Brooklyn for many valuable suggestions. To Professor Robert Spice and to the late Professor William A. Anthony the author is especially indebted for assistance and inspiration afforded to him in his student days by their experimental lectures. It is to them that he owes his realization of the importance of such lectures in practical education.

SYDNEY WHITMORE ASHE.

BROOKLYN, N.Y.,  
May, 1910.

# TABLE OF CONTENTS

## CHAPTER I

### **Magnetism**

	PAGES
Lodestone. Magnet. Earth as a Magnet. Horseshoe Magnet. Molecular Theory of Magnetism. Magnetic Induction. Effect of Temperature upon Magnetizability. The Effect of Vibration upon Magnetizability. The Obtaining of a Hysteresis Cycle. How to plot the Hysteresis Curve. Magnetic Field. A Magnet Pole travels along Lines of Force. Mayer's Needles. Practical Applications of Permanent Magnets. Ammeters, Voltmeters, Relays, Thomson Recording Wattmeters, Telephone Receivers. Questions . . .	1-24

## CHAPTER II

### **Electro-magnetism**

The Magnetic Field around a Straight Wire carrying a Current. The Compass Needle always tends to set itself Parallel to the Lines of Force. Effect of Current in a Coiled Wire. A Large Coil for Experimental Purposes. Limit Switch, Overload Relays. The Electro-dynamometer. Permeability, Saturation of Iron. The Electro-magnet. The Blow-out Magnet. Applications of Electro-magnetism. Electric Bells, Buzzers, Relays, Sounders. The Electric Motor. Thomson Inclined Coil Ammeters and Voltmeters. Thomson Inclined Coil Wattmeter. Weston Indicating Wattmeter. Traction Electro-magnets. Questions . . . . .	25-45
---	-------

## CHAPTER III

### **Electro-magnetic Induction—Theory of the Dynamo**

Faraday's Discovery. Relation of Turns, Flux, Speed of Coil to E. M. F. Generated. Generators. Motor Generators, Double Current Generators, Rotary Converters, Balances. Variation of E. M. F. of	
---	--

	PAGES
Generator. Magnetization Curve of a Shunt Dynamo. Residual Magnetism. Mutual Induction. Foucault or Eddy Currents. Applications of Foucault Currents. Practical Applications of Induction. Rumkorff Coil, Telephone Circuit, Wireless Circuit. Wireless Sending and Receiving Apparatus. Questions . . .	46-58

#### CHAPTER IV

##### Ohm's Law

Electro-motive force, Current, Resistance. Resistance Defined. Ohmic-values of Resistance. Circular Mil. Resistance of Copper Conductors. Temperature Coefficient. Wire Table. Electro-motive Force Defined. Standard Cells. Carhart-Clark Cell. Weston Cell. Current Defined. Values of Current. Ohm's Law. Applications of Ohm's Law. Example. Questions . . .	59-76
--	-------

#### CHAPTER V

##### Primary and Storage Batteries

The Simple Cell. Galvani's Experiment. Chemical Action of Cell. E. M. F.'s of Cell. Effect of Changing Electrolytes. Polarization. Effect of Changing Electrodes. Depolarizers. Electrolytic Depolarizers. Electrolytic Condensers. Closed Circuit Cells. Daniell Cell. Local Action. Gravity Cell. Plating of Copper. Bunsen and Grove Cells. Grenet Cell. Open Circuit Cells. Leclanché Cell. Dry Cells. The Storage Battery. Theory of the Storage Battery. Operation of a Storage Battery. Rating of Cells. How to charge a Storage Battery. Edison Cell. Types of Commercial Cells. Questions . . .	77-100
--	--------

#### CHAPTER VI

##### Electrolysis

Electrolytic Corrosion. Definition of an Electrolyte. Positive and Negative Temperature Coefficients. Decomposition of Acid Solutions. Electro-chemical Equivalents. Hoffman Voltmeter. Electro-chemical Equivalent of Hydrogen. Polarity Indicator. Metallic Salt Solution. Electroplating. Copper Plating. Gold Plating. Silver Plating. Nickel Plating. Brass-plating Solution.
--

	PAGES
Plating E. M. F.'s. Critical Current Density. Electrolytic Products. Alkalies and Bleach. Sodium. Aluminium. Potassium Chlorate. Sponge Lead. The Electric Furnace and its Products. Graphite. Calcium Carbide. Carborundum. Barium Hydrate. Miscellaneous Substances. The Electrolytic Rectifier. Electrolytic Interrupter. The Pail Forge. Questions . . . . .	101-118

CHAPTER VII

**The Three-wire System**

Two-wire System. Three-wire Edison System. Three-wire System with Generator. Three-wire System Converter. Theory of the Three-wire System. Experiment on Three-wire System. Old and New Style Branch Circuits. Questions . . . . .	119-124
--	---------

CHAPTER VIII

**Electrical Measurements**

Ammeter and Voltmeter Method of Measuring Resistance. Measuring Resistance of Voltmeter. Voltmeter Method of Measuring Resistances. Comparison of Resistances with Voltmeter. Calibration of an Ammeter. Lamp Boards. Calibration of Ammeters. Series Method. Calibrating Rotary Ammeter. Calibrating Feeder Ammeter. Calibration of a Voltmeter. Potentiometer Method of Calibrating a Voltmeter. Calibration of an Indicating Wattmeter. Wheatstone Bridge Method of Measuring Resistance. Post-office Box. Slide Wire Bridge. Wire Roller Bridge. Resistance of an Electrolyte. Carey-Foster Bridge. Thomson Double Bridge. Insulation Test. The Galvanometer. How to set up a Galvanometer. Determination of Resistance of Galvanometer. Determination of the Constant of a Galvanometer. Measurement of Capacity. Commercial Testing Sets. Questions . . . . .	125-151
---	---------

CHAPTER IX

**The Shunt Motor**

The Shunt Motor. Testing out Circuits. Measuring Armature and Field Resistance. Magnetic Circuit of Field Coils. Tests for Improper Connection of Field Coils. Magnetic Circuits of Armature.	
---	--



	PAGES
Magnetic Circuits of Armature and Field. Neutral Plane. Changing Direction of Rotation. Operating Connections. Armature Circuit. Counter Electro-motive Force. Starting Boxes. Directions for Connecting up a Shunt Motor. Magnet Arm on Starting Box. Overload Release. Changing Direction of Rotation. Speed Variation. Rheostats. How to tell whether Field Resistance is All In or All Out. Theory of Speed Variation. Location of Trouble. Tests for Grounds. Tests for Short Circuits. Resistance of Ground. Interpole Motors. Questions . . . . .	152-173

## CHAPTER X

### The Series Motor

Characteristics of the Series Motor. Magnetic Circuits of the Series Motor. Resistance of Armature and Field Circuits of the Series Motor. Starting of a Series Motor. Speed and Tractive Effort Curves. Relation of Torque to Tractive Effort of Series Motor. Relation of Current Input, Speed, Torque, and Voltage of a Series Motor. Changing Direction of Rotation. Railway Controllers. Two and Four Motor Equipments. Bridge Control. Multiple Unit Control. Emergency Brake of the Series Motor. Testing out Controller. Structural Features of Motor. Questions . . . . .	174-185
--	---------

## CHAPTER XI

### The Arc Light

The Carbon Arc. Spectrum of Arc. Physics of Carbon Arc. Intrinsic Brightness of Illuminants. Efficiency of Light-giving Bodies. The Ultra Rays. Arc Lamp Circuits. Alternating Arc Circuit. Inclosed Arcs. Recent Developments in Arc Lamps. Factors to be considered in Selecting an Illuminant. Holophane Reflectors. The Flaming Arc. The Magnetic Arc. Questions . . . . .	186-201
--	---------

## CHAPTER XII

### Incandescent Illuminants

The Carbon Incandescent Lamp. Early Discoverers. Edison's First Lamp. Making the Carbon Filament. Treating the Filament. Mounting the Filament. Characteristics of Filaments. The Tan-	
--	--

## TABLE OF CONTENTS

xi

	PAGES
talum Lamp. The Tungsten Lamp. The Tungsten Filament. The Moore Vacuum Tube. Feeder Valve for Moore Tube. The Cooper-Hewitt Mercury Vapor Lamp. The Nernst Lamp. Questions . . . . .	202-220

### CHAPTER XIII

#### Recording Wattmeters and their Use

Old Edison Bottle Meter. Thomson Recording Wattmeter. Armature, Armature Resistance, Compensating Coil, Field Coils, Magnets, and Gears of Thomson Recording Wattmeter. Type C Thomson Recording Wattmeter. Friction of Recording Wattmeter. Testing Meters. The Direct Method of Testing. The Rotating Standard Method. The Standardized Resistance Method. Load Box of Boston Edison Company. Installation Tests. Inspection Tests. How to make Tests. Method of Determining Normal Load. Modern Meter Installations. Meter Wiring. Questions . . . . .	221-241
---	---------

### CHAPTER XIV

#### Elementary Principles of Alternating Currents

Definition of an Alternating Current. Comparison with Direct Current. Instantaneous Current Curve. Sine Curve. Generation of E. M. F.'s. The Contact Maker. Balance Set to obtain E. M. F.'s. Method of Balancing E. M. F.'s. Oscillograph. Effective Current Values. Form Factor. Alternating Current Generators, Various Types. Capacity. Effect of Capacity in an Alternating Current Circuit. Capacity and Current Relation. Capacity Reactance. Series Parallel Combination of Condensers. Self-induction. Derivation of Capacity and Self-induction Formulae. Relations of Resistance and Inductive E. M. F.'s. Relation by Means of Vectors of Resistance and Inductive E. M. F.'s. Vectors. Vector Relations in Single and Three-phase Circuits. Trigonometric Expressions. Meaning of Sines, Cosines, Tangents. Values of Sines, Cosines, Tangents. Circuits containing Resistance, Inductance, Capacity. Mathematical Relation of Inductance, Resistance, and Capacity. Series and Multiple Circuits. Reactance and Admittance Defined. Power in a Single-phase Circuit. Power Factor. Determination of Power Factor. Power Measurements in a Three-phase Circuit.	
--	--

	PAGES
Tangent Formulæ. Single-phase Induction Wattmeters. Poly-phase Integrating Wattmeter. Three-phase Circuit Current Lagging 30°. Questions . . . . .	242-282

## CHAPTER XV

**The Alternating Current Transformer**

Theory of the Transformer. Relation of Transformer E. M. F.'s. Relation of Instantaneous E. M. F.'s. Operation of Transformer. Efficiency and Losses of a 400-kw. and an 800-kw. Transformer. Construction of a Modern Transformer. Experiments on Transformers. Types of Transformers. Manhole Transformers. Station Transformers. Six-phase Connections. Ratio of Transformers. Questions . . . . .	283-298
---	---------

## CHAPTER XVI

**The Induction Motor**

Theory. Windings. Slip. Experiments showing Poles, Transformer Features, Rotating Field, etc. Operation of an Induction Motor. Starting. Changing Direction of Rotation. Care of Induction Motors. Questions . . . . .	299-306
--	---------

## CHAPTER XVII

**The Rotary Converter**

Theory of E. M. F. Relations. Methods of Starting. Starting from Direct Current Side. Starting by Means of Induction Motor. Starting from Alternating Current Side. The Hunting of a Rotary Converter. Synchronizing. Synchronizing with a Voltmeter. Synchronizing with a Frequency Changer. Crossed Phases. Meaning of Unity Power Factor. Converters operating in Parallel. Recent Developments in Converters. The Booster Converter. The Interpole Converter. Rotary Converters <i>versus</i> Motor Generators. Questions . . . . .	307-327
---	---------

## APPENDIX

Experimental Projecting Apparatus . . . . .	329-341
Formulæ . . . . .	342

## LIST OF ILLUSTRATIONS

FIG.	PAGE
1, 2, 3. Magnetic Spectrum. Compass. Repulsion of Magnets . . . . .	2
4, 5. Attraction of Magnets. North Magnetic Pole . . . . .	3
6. Magnetic Pole . . . . .	4
7. Horseshoe Magnet from Weston Voltmeter . . . . .	5
8. Molecular Magnets . . . . .	6
9, 10. Magnets made by breaking Magnetized Needle. Magnetic Induction . . . . .	7
11. Magnetization Loss with Heat . . . . .	8
12. Keeper and Magnet . . . . .	9
13. Set-up for obtaining Hysteresis Curve . . . . .	11
14. Hysteresis Curve . . . . .	12
15. Partial Hysteresis Curve . . . . .	13
16, 17, 18, 19. Magnetic Spectrum. Shaker for Filings. Path of Lines of Force. Cross Magnetization . . . . .	14
20 a. Set-up showing that Magnet Pole travels along Lines of Force . . . . .	15
20 b, 21. Small Electro-magnet. Molecular Magnets . . . . .	16
22, 23, 24. Movement of Weston Standard Voltmeter. Weston Standard Voltmeter Complete. Station Type of Weston Voltmeter . . . . .	17
25, 26, 27. Laboratory Standard Weston Voltmeter. Weston Station Type of Ammeter. Magnets of Thomson Recording Wattmeter . . . . .	18
28. Thomson Recording Wattmeter . . . . .	19
29, 30. Telephone Receiver (M. E. S. Co.). Weston Speed Tachometer . . . . .	20
31, 32. Weston Relay. Wattmeter Disc . . . . .	21
33. Weston Ammeter, Central Zero, with Shunt . . . . .	22
34, 35, 36. Magnetic Field around Wire. Presence of Field shown with Filings. Field shown with Compass . . . . .	25
37, 38. Support for Compass for Projection. Neutralization of Magnetic Field . . . . .	26
39, 40. Wire carrying Current tends to encircle Magnet. Helix . . . . .	27
41, 42. Solenoid (termed Long Tom). Sucking Coil . . . . .	28
43. Limit Switch (Westinghouse) . . . . .	29
44. Electro-dynamometer . . . . .	30

FIG.	PAGE
45, 46. Magnetization Curve. Filings showing Strength of Electro-magnet . . . . .	32
47, 48, 49, 50. Nails showing Distribution of Flux of Magnet. Diaphragm and Magnet. Tracing the Field. Principle of Edison Ore Separator . . . . .	33
51, 52, 53. Arc extinguished with Magnet. Arc extinguished with Electro-magnet. Electric Bell (M. E. S. Co.) . . . . .	34
54, 55, 56, 57. House Bell Circuit (M. E. S. Co.). Circuit of Electric Bell. Telegraph Line. Transmission Key (M. E. S. Co.) . . . . .	35
58, 59, 60. Relays (M. E. S. Co.). Sounder. Electric Motor . . . . .	36
61, 62. Armature of Motor (Westinghouse). Field Coils of Motor (Westinghouse) . . . . .	37
63. Induction Motor (G. E. Co.) . . . . .	38
64, 65, 66. Commutator (Westinghouse). Series Winding. Rotation of Armature . . . . .	39
67, 68, 69, 70. Shunt Connection. Series Connection. Armature and Field Symbols. Cross-section of Armature (Westinghouse) . . . . .	40
71, 72. Thomson Inclined Coil Ammeters (Section). Thomson Inclined Coil Ammeter . . . . .	41
73. Weston Wattmeter Movement . . . . .	42
74. Tractive Magnet built by Cutler Hammer Clutch Co. . . . .	43
75, 76, 77. Method of Generating Zero E. M. F. Lines of Force not Interlinked. Generating an E. M. F. (Magnet and Coil) . . . . .	46
78. Generating an E. M. F. (Coil and Coil) . . . . .	47
79. Rotary Converter (G. E. Co.) . . . . .	48
80. Motor Generator (Westinghouse) . . . . .	49
81, 82. Motor Generator (G. E. Co.). Circuit of Motor Generator . . . . .	50
83, 84. Circuit of Balances. Field Circuit of Generator . . . . .	51
85, 86. Magnetization Curve. Excitation of Generator . . . . .	52
87. Principle of Induction . . . . .	53
88. Wattmeter Disc with Magnets . . . . .	54
89, 90. Principle of Eddy Currents. Insulation of Eddy Currents . . . . .	55
91, 92, 93, 94. Ruhmkorff Coil. Shocking Coil. Telephone Circuit. Wireless Circuit . . . . .	56
95, 96. Wireless Sending Apparatus. Wireless Receiving Apparatus . . . . .	57
97. Desk Telephone . . . . .	58
98. Car Resistance . . . . .	60
99. Circular Mil . . . . .	61
100, 101. Principle of Distribution of Potential. Carhart-Clark Cell . . . . .	66
102 a, 102 b. Weston Cell. Weston Cell (Interior View) . . . . .	67-68
103. Ohm's Law Illustrated . . . . .	72

*LIST OF ILLUSTRATIONS*

XV

FIG.	PAGE
104. Method of obtaining Low Voltage . . . . .	75
105, 106. Galvani's Experiment. Voltaic Cell . . . . .	77
107. Projecting Tank . . . . .	78
108, 109. Support for Electrodes. Support in Position . . . . .	79
110. Polarization Tank . . . . .	80
111. Carbon Cell . . . . .	81
112, 113. Electrolytic Condenser. Electrolytic Cells in Series . . . . .	82
114, 115, 116. Gravity Cell. Copper Electrode. Crowfoot Zinc . . . . .	85
117. Plating of Copper . . . . .	86
118, 119. Leclanché Cell. Zinc for Leclanché Cell . . . . .	87
120, 121. Mesco Dry Cell. Red Seal Dry Cell . . . . .	88
122. Variation of Resistance of $H_2SO_4$ . . . . .	90
123, 124. High Resistance of Pure Water. Conductivity of $PbO_2$ and $PbSO_4$ Shown . . . . .	91
125. Battery Pellet . . . . .	92
126, 127, 128. Battery Discharge Curve. Testing Sulphated Plate. End Cells . . . . .	93
129, 130, 131. Battery Charging Circuit. Test Hydrometer. Charging Circuit . . . . .	94
132. Charging Circuit . . . . .	95
133, 134. Tudor Plates. Laboratory Chloride Cell . . . . .	96
135, 136. Telephone Chloride Cell. Box Negative . . . . .	97
137, 138. Exide Battery. Manchester Positive . . . . .	98
139, 140. Rolled Negative. Shelf Negative . . . . .	99
141, 142, 143. Conductivity of Sodium Acetate with Heat. Positive Temperature Coefficient. Negative Temperature Coefficient . . . . .	102
144, 145. Electrolysis Projecting Tank. Decomposition of Acid Solutions . . . . .	104
146, 147. Hoffman Voltmeter. Electro-chemical Equivalent of Hydrogen . . . . .	105
148, 149. Polarity Indicator . . . . .	107
150. Critical Current Density Apparatus . . . . .	111
151. Wehnelt Interrupter . . . . .	117
152. The Pail Forge . . . . .	118
153, 154, 155. Two-wire System. Edison Three-wire System. Three-wire System (Generator) . . . . .	119
156, 157, 158, 159, 160. Three-wire System (Converter). Principle of Three-wire System . . . . .	120-121
161. Experiment on Three-wire System . . . . .	123
162, 163. Old Style Branch Circuits. Approved Branch Circuits . . . . .	124
164. Ammeter-voltmeter Method of Measuring Resistance . . . . .	125

FIG.	PAGE
165, 166, 167. Measurement of Resistance of Voltmeter. Weston Voltmeter Circuit (Station Instrument). Weston Voltmeter Suspension . . . . .	127
168. Measuring Resistance with Voltmeter . . . . .	128
169, 170. Showing Distribution of Potential. Standard Resistance . . . . .	129
171, 172, 173, 174. Method of Connecting Contacts. Potential Taps. Lamp Board . . . . .	130
175, 176. Calibrating Rotary Ammeter. Calibrating Feeder Ammeter . . . . .	131
177, 178. Calibrating Ammeters in Laboratory. Calibrating a Voltmeter . . . . .	132
179, 180. Leeds and Northrup Company Potentiometer. Circuits of Leeds and Northrup Company Potentiometer . . . . .	133
181, 182. Diagram of Potentiometer Circuit. Standard Cell Circuit . . . . .	134
183. Indicating Wattmeter Circuit . . . . .	136
184, 185, 186, 187, 188, 189, 190. Calibration of Indicating Wattmeter. Principle of Wheatstone Bridge . . . . .	137-138
191. Post-office Box . . . . .	139
192, 193. Galvanometer Shunt. Various Arrangements of Four-series Resistances . . . . .	140
194. Slide Wire Bridge . . . . .	141
195 a, 195 b, 196. Wire Roller Bridge . . . . .	142
197, 198. Resistance of Electrolyte. Carey-Foster Bridge . . . . .	143
199. Insulation Test . . . . .	145
200. Galvanometer . . . . .	146
201. Measuring Resistance of Galvanometer . . . . .	147
202, 203. Method of obtaining Low Potential. Low Potential Obtained . . . . .	148
204, 205. Measurement of Capacity. Substituting Switch . . . . .	149
206, 207, 208, 209, 210. Queen Slide Wire Bridge. Queen Acme Testing Set. Queen Decade Testing Set. Queen Laboratory Wheatstone Bridge. Queen Wheatstone Bridge . . . . .	150
211. CQ. Motor installed on Ceiling . . . . .	152
212. Testing out Circuits of Motor . . . . .	153
213. Shunt Machine . . . . .	154
214, 215, 216. Magnetic Circuits of Motor. Testing out Magnetic Circuits . . . . .	155
217. Magnetic Circuits of Armature . . . . .	156
218, 219. Changing Direction of Rotation. Measuring Field Current . . . . .	157
220. To show Induction of Field Winding . . . . .	158
221. Starting of Shunt Motor . . . . .	159
222. Starting Box . . . . .	160
223. Starting Box Full On . . . . .	161

*LIST OF ILLUSTRATIONS*

xvii

FIG.	PAGE
224. Starting Box (Westinghouse) . . . . .	162
225. Cutler Hammer Starting Box . . . . .	163
226. Motor Circuits . . . . .	164
227, 228. Field Circuit. Remote Control Resistance . . . . .	165
229. Self-contained Rheostat (G. E. Co.) . . . . .	166
230, 231, 232, 233, 234. Dial of Rheostat. Circuits of Rheostat. Field Rheostat. Cross-section of Cutler Hammer Rheostat. Burnt out Rheostat . . . . .	167
235. Test for Grounded Armature . . . . .	169
236, 237, 238. Test for Grounded Field Coil. Test for Short-circuited Field Coils. Test for Short-circuited Armature Coils . . . . .	170
239. Test of Grounded Switchboard . . . . .	171
240. Interpole Motor (G. E. Co.) . . . . .	172
241. Series Motor Circuit . . . . .	174
242. Measuring Resistances of Series Motor . . . . .	175
243, 244. Tractive Effort of Series Motor. Relation of Torque to Trac- tive Effort of Series Motor . . . . .	177
245. Characteristic Curves of Series Motor . . . . .	178
246, 247. Measuring Torque of Series Motor. Measuring Speed of Series Motor . . . . .	179
248, 249. Showing Relation of Speed to Current. Circuits for Changing Direction of Rotation of Series Motor . . . . .	180
250, 251, 252. Two Motors in Series. Two Motors in Parallel. Four Motors in Series . . . . .	181
253, 254, 255. Four-motor Equipment. Four Motors in Parallel. Bridge Control . . . . .	182
256. Alternating Current Arc . . . . .	186
257. Method of obtaining Spectrum . . . . .	187
258. Temperature shown with Thermo Element . . . . .	190
259, 260. Iron Arc. Sign . . . . .	192
261, 262. Simple Arc Circuit. G. E. Arc Mechanism . . . . .	193
263. Both Carbons Down-feed . . . . .	196
264. Holophane Reflector . . . . .	198
265. Carbon Incandescent Lamp . . . . .	202
266. Squirted Filaments (Westinghouse Lamp Works) . . . . .	204
267. Drying Filaments (Westinghouse Lamp Works) . . . . .	205
268. Bulb with Tip Added . . . . .	207
269, 270. Filament Mount. Bulb ready for Exhaust . . . . .	208
271. Tantalum Lamp . . . . .	209
272, 273. Tantalum Filament. Circuit illustrating Positive and Nega- tive Temperature Coefficient . . . . .	210



FIG.	PAGE
274. Circuit to show Variation in Candle Power with Pressure . . . . .	211
275. Tungsten Lamp . . . . .	213
276. Moore Tube . . . . .	214
277. Feeder Valve for Moore Tube . . . . .	215
278. Cooper-Hewitt Tube . . . . .	216
279. Circuits of Cooper-Hewitt Tube . . . . .	217
280. Westinghouse Nernst Lamp . . . . .	218
281, 282. Glowler. Circuits for Nernst Lamp . . . . .	219
283. Armature of T. R. W. . . . .	221
284, 285. Armature Resistance, T. R. W. Compensating Coil . . . . .	222
286, 287, 288, 289. Field Coil, T. R. W. Magnets, Type C Meter. T. R. W. Gear . . . . .	223
290. Type C, T. R. W. . . . .	225
291. Parts of Type C, T. R. W. . . . .	224
292. Spring Brushes, T. R. W. . . . .	225
293. Cover of Old Style T. R. W. . . . .	226
294, 295. Wattmeter Circuit . . . . .	227
296. Friction Curves of Meters . . . . .	228
297. Calibrating a Meter . . . . .	229
298. Standardized Resistance used by the Boston Edison Co. . . . .	231
299. Load Box, Boston Edison Co. . . . .	232
300. Service Test of Meter . . . . .	233
301. Field Coils of Meter improperly Connected . . . . .	234
302. Typical Meter Installation, Alternating Current Service . . . . .	236
303, 304. Typical Service of Meters. Combination Direct Current and Alternating Current Service . . . . .	237
305. T. R. W. and Type C Meter Service . . . . .	238
306, 307. Typical Direct Current Service. Single A. C. Service . . . . .	239
308. Typical Meter Installation . . . . .	240
309. Instantaneous Current Curve . . . . .	243
310, 311, 312. Sine Curve. Generation of E. M. F. . . . .	244
313, 314. Contact Maker . . . . .	245
315, 316. Using a Balance Set to obtain E. M. F. Curve. Method of Balancing E. M. F.'s . . . . .	246
317. Balance Apparatus . . . . .	248
318. Interior of Weston Alternating Current Voltmeter . . . . .	251
319, 320, 321, 322. Single-phase Generator. Three-phase E. M. F.'s. Three-phase Generator. Inductor Generator . . . . .	253
323, 324. Experiment showing Charging of Cables. Dielectric Polari- zation . . . . .	254
325. Experiment showing Charging of Condensers with Direct Current . . . . .	255

## LIST OF ILLUSTRATIONS

xix

FIG.	PAGE
326. Capacity and Current Relations . . . . .	256
327, 328. Relation of Sides in Right Angle Triangle. Condensers in Series . . . . .	258
329. Condensers in Parallel . . . . .	259
330. Relation of Resistance and Inductive E. M. F.s . . . . .	263
331, 332, 333. Line E. M. F. and Counter E. M. F. Resistance and Inductive E. M. F.'s. Alternating Current E. M. F. Curve . . . . .	264
334. Relation of Current and Inductive E. M. F.'s . . . . .	265
335, 336. Vector. Vector Relation of Inductance and Current . . . . .	266
337, 338, 339, 340. E. M. F. and Current in Phase. Vector Relation of Current and Capacity Reactance. Y-connection for Three-phase Circuit. Relation of Transformer E. M. F.'s . . . . .	267
341, 342. Resistance alone in Circuit. Vector Relation of Resistance and Inductance . . . . .	268
343. Trigonometric Relations in a Right Triangle . . . . .	269
344, 345, 346, 347. Vector Relation of E. M. F.'s. Effect opposite to Fig. 345. Ohmic Relation of Resistance and Reactance . . . . .	271
348, 349, 350. Parallel Arrangement of Reactances. Vector Relation Admittance. Power in a Single-phase Circuit . . . . .	273
351. E. M. F. and Current in Phase . . . . .	274
352, 353. E. M. F. and Current out of Phase. Unity Power Factor . . . . .	275
354. Experimental Method of Measuring Power Factor . . . . .	276
355. Power Measurement in a Three-phase Circuit . . . . .	277
356, 357. G. E. Single-phase Induction Wattmeter . . . . .	278
358, 359, 360. Jewel Support of Wattmeter. Induction Wattmeter. Vector Relation of Single-phase Meter E. M. F.'s . . . . .	279
361, 362. Vector Relation of Current and Potential Vectors in a Polyphase Meter. Polyphase Meter Vectors, Current Lagging $30^\circ$ . . . . .	281
363. Experimental Study of Transformer . . . . .	283
364, 365. Simple Transformer. Relation of Transformer Vectors . . . . .	284
366, 367, 368. Relation of Instantaneous E. M. F.'s in a Transformer. Load connected to Transformer. Load connected to 1 : 1 Transformer . . . . .	285
369. Modern Method of Building Transformers . . . . .	287
370, 371, 372. Cross-section of Fig. 369. Queen & Co. Experimental Transformer. Showing Principle of Transformer . . . . .	288
373, 374, 375, 376. Reluctance of Transformer Air Gap Shown. Study of Transformer. Varying Reluctance of Transformer. Measuring Copper Loss of Transformer . . . . .	289
377, 378, 379. Efficiency of Transformer. Manhole Transformer. Manhole with Transformer Installed . . . . .	290

FIG.	PAGE
380. Waterproof Terminals for Subway Transformer . . . . .	291
381, 382. Station Transformer Connections, Six-phase . . . . .	292-293
383, 384. Type H Transformers 1 : 2 Ratio. Type H Transformer 1 : $\frac{1}{2}$ Ratio . . . . .	296
385, 386, 387. Ratios of Transformers. Neutralizing Self-induction of Transformer. Transformer Secondaries in Series . . . . .	297
388. Transformer Secondaries connected in Opposition . . . . .	298
389. Induction Motor . . . . .	299
390. Experimental Study of Induction Motor . . . . .	300
391, 392, 393. Copper Sphere. Transformer Feature of Induction Motor Shown. Poles of Induction Motor Shown . . . . .	301
394, 395. Progression of Poles of Induction Motor with Current. Two- phase Induction Motor . . . . .	302
396. Three-phase Induction Motor operated from Single-phase Circuit	303
397. Induction Motor operating a Blower . . . . .	304
398. Converter Armature . . . . .	308
399. Synchronizing with Lamps . . . . .	315
400. Synchronizing with Lamp connected to Transformers . . . . .	316
401, 402. Synchronizing Two Converters. E. M. F. Relations when Machines are out of Phase . . . . .	318
403, 404. Crossed Phases. Unity Power Factor of Converters . . . . .	319
405. Experiment illustrating Unity Power Factor . . . . .	320
406, 407, 408. Booster Converter . . . . .	322-323
409, 410, 411. Position of Zero Boost on Converter. Boost in a Positive Direction. Boost in a Negative Direction . . . . .	324
412, 413. Interpole Converter . . . . .	325-326
414. Experimental Lantern arranged for Horizontal Projection . . . . .	330
415, 416. Experimental Lantern arranged for Vertical Projection. Sin- gle Lantern . . . . .	331
417. Lantern Set-up . . . . .	333
418. Two Lamps in Series . . . . .	335
419. Automatic Arc Lamps . . . . .	337
420. Combination Beseler Double Lantern and Moving Picture Ap- paratus . . . . .	338
421, 422. Weston Projecting Instruments. Combination Board used with Projecting Galvanometer . . . . .	340

# EXPERIMENTAL ELECTRICITY

## CHAPTER I

### MAGNETISM

**Lodestone.**—Lodestone is an oxide of iron, *magnetite*,  $\text{Fe}_3\text{O}_4$ , which has the property of attracting small particles of iron and, when freely suspended, of assuming a position pointing north and south. It also has the characteristic of imparting its properties to a piece of steel that has been rubbed by it. It is quite heavy, of a black lead color, of considerable hardness, and is usually found in iron mines in various parts of the world. The name “magnet” as applied to the *lodestone*, leading stone, not load stone, is derived through the Latin *magnes* or the Greek *μάγνης*, meaning *magnet*. It is supposed that the Chinese used small pieces of this stone suspended as compasses two thousand years before the Christian era. A description of a primitive form of compass in use on the Syrian coast was given by Kibdjaki in 1242 A.D. In 1260, on the return of Marco Polo from Cathay, he brought a knowledge of the compass as used by the Chinese. The Italians give to Flavio Gioja the credit of inventing the compass in 1300–1320, but it is probable that he simply improved upon the old form of the instrument.

**Magnet.**—If a piece of steel is placed in a coil of wire carrying an electric current, it becomes *magnetized*. This magnetic condition of the steel may be observed by

placing over the steel a piece of paper and sprinkling it with iron filings, thus obtaining a *magnetic spectrum*.

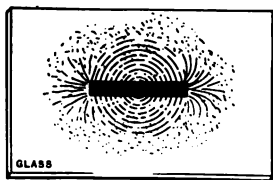

FIG. 1. — Magnetic Spectrum.

In observing this spectrum it will be noted that the attraction of the magnet for the filings is greatest at both extremities of the magnet, *the poles*, and that it is practically zero at the middle of the magnet. Now, if we substitute for the paper a piece of thin glass, Fig. 1, and repeat the experiment, we shall note that the power of the magnet to attract the filings still exists. This fact leads to the conclusion that —

*Magnetism cannot be Insulated.*

**Experiment 1.** Place a piece of paper over a magnet and obtain a spectrum. Note that the lines of the spectrum seem to pass out from one pole and enter the other pole as though this imaginary force traveled in curves.

If a small magnet be pivoted, Fig. 2, so that it is free to move, it will assume a definite direction pointing *north and south*. When a magnet is thus mounted, it is termed a *compass*. Bringing another magnet near a compass needle so that the north pole of the magnet is near the north pole of the compass, Fig. 3, a *repulsion* of the end of the compass

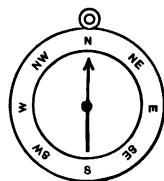

FIG. 2. — Compass.

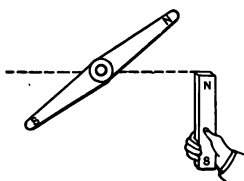

FIG. 3. — Repulsion of Magnets.

needle occurs. The same effect will be noted if two south poles are brought near each other. If, however, a *north pole and a south pole* be brought near each other, Fig. 4, *attraction* of the compass needle occurs.

*Like poles repel each other, and unlike poles attract each other.*

**Experiment 2.** Bring near a compass needle first the north pole of a magnet and then the south pole, noting the result. Bring one end of a non-magnetized piece of iron near first the north and then the south pole of a compass needle, and note that the piece of iron attracts both ends. Also note that either end of the iron rod has the same effect on the magnet. Why?

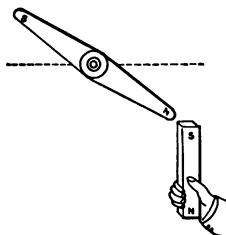

FIG. 4. — Attraction of Magnets.

**Earth as a Magnet.** — A compass needle assumes the position pointing north and south because the earth possesses the property of a magnet, having a *magnetic north* and a *magnetic south pole*. The north magnetic pole is at some distance from the axial *North Pole*. The magnetic pole of the earth nearest the North Pole is termed the *North Magnetic Pole*, Fig. 5. A compass needle

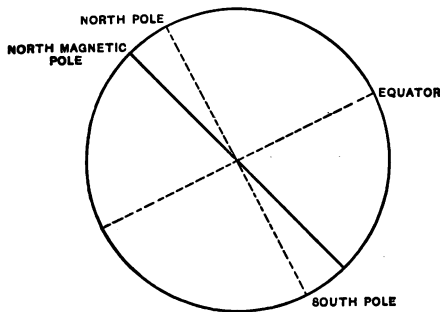

FIG. 5. — North Magnetic Pole.

points its north-seeking pole in the direction of the north magnetic pole. This is in reality a south pole; but as it seeks the north pole, we designate it as the north pole. This deviation of the magnetic pole from the axial pole becomes more and more marked as the

compass needle is located farther and farther north on the earth. As the compass needle approaches the north

geographical pole of the earth, it is affected by the north magnetic pole in the same manner as it would be if it were approaching the pole of a magnet; thus it *dips* more and more. The north magnetic pole in the northern hemisphere of the earth is located at Boothia Felix, Fig. 6, at about latitude 70 and longitude 96 west.



FIG. 6.—Magnetic Pole.

**Horseshoe Magnet.**—If a bar of steel in the form of a horseshoe be magnetized, it will be found that the strength of the magnet appears to be greater than if the same piece of steel had been magnetized in the shape of a bar. This is due to the fact that the magnetic emanations which issue from the north pole cover an air gap, as indicated by the curved lines in Fig. 1, and enter the south pole. In traversing this *air gap* the magnetic emanations suffer a much greater resistance, termed *reluctance* for magnetic circuits, than if iron were substituted for it. In bringing the north

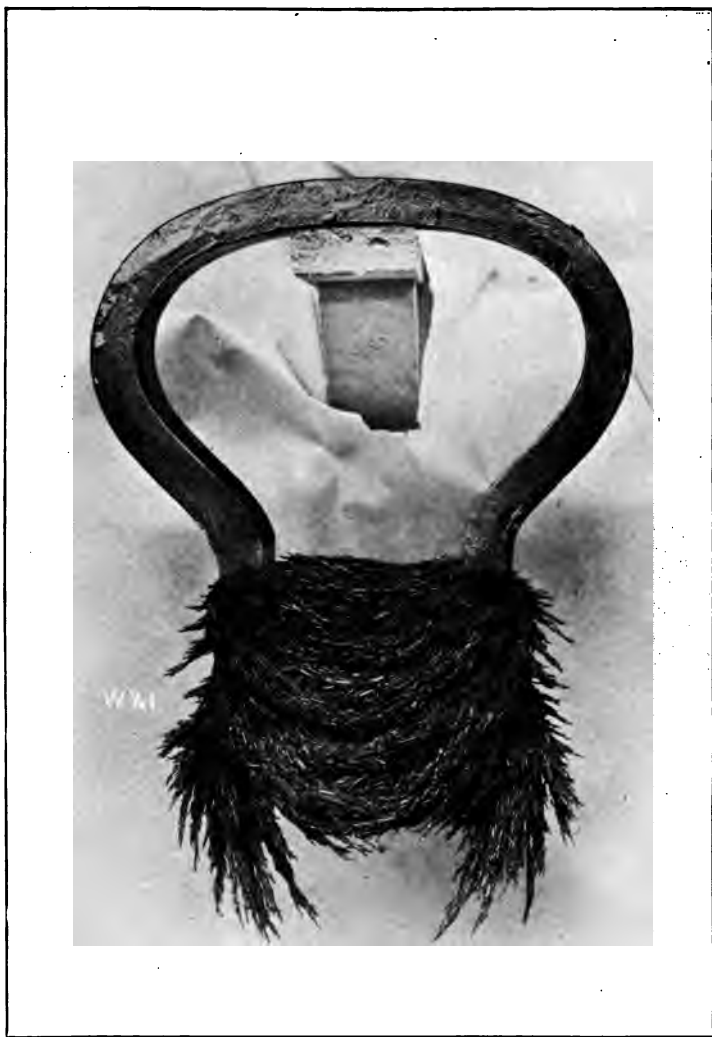

FIG. 7. — Horseshoe Magnet from Weston Voltmeter.



and south poles close together as in a horseshoe magnet, the air gap, or path of the magnetic circuit, is considerably reduced, increasing the apparent strength of the magnet. Figure 7 illustrates an excellent and powerful horseshoe magnet used by the Weston Instrument Company for their portable ammeters and voltmeters for direct current work. By shaping the pole pieces of a magnet in the form of arcs, Fig. 22, it is possible to distribute the magnetic emanations and accommodate a movable coil and iron core, reducing the *magnetic leakage* to a minimum. The presence of a circular iron core reducing the *air gap* to a minimum, Fig. 22, seems to facilitate the passage of these magnetic emanations. We speak of such magnetic emanations as *lines of force*, and of the total lines of force as the *flux* of a magnet. Where the flux per square inch or per square centimeter is meant, the term *flux density* is employed. Most magnetic formulæ employ the unit flux density, and in calculating the total flux, care must be taken to multiply by the area.

*Lines of force pass much more readily in iron than in air.*

**Molecular Theory of Magnetism.** — Ewing carried on a large number of tests which seemed to indicate that a

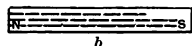
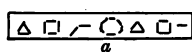

FIG. 8. — Molecular Magnets.

piece of unmagnetized iron or steel is composed of a large number of infinitely small magnets that assume geometric figures, Fig. 8 *a*. When a magnetizing force is placed in the vicinity of a piece of steel so that the steel becomes magnetized, all of these molecular magnets arrange themselves in parallel formation as in Fig. 8 *b*. This increases the magnetic strength of the steel, producing a north pole at one end and a south pole at the other end.

**Experiment 3.** Take a sewing needle, unmagnetized, and dip it in iron filings; no filings will cling to it. Magnetize the needle by stroking it with one pole of a bar magnet, dip it in filings again, and notice that the filings are attracted to the ends of the needle. Break the magnetized needle in two, dip both magnetized pieces in filings, and notice that two magnets, Fig. 9, are produced. Break one of the smaller pieces in two, and dip the pieces in filings, and notice that two more magnets are produced. This process of breaking the smaller pieces in two could be continued until only a molecule of the material remained, when it would probably be found that the molecule was a magnet possessing a north and a south pole. (This experiment can be readily performed on a vertical lantern.)



FIG. 9. — Magnets made by breaking Magnetized Needle.

**Magnetic Induction.**— A piece of soft iron placed in the vicinity of a magnet or in contact with the magnet assumes the properties of the magnet, attracting iron filings, Fig. 10. This phenomenon is termed *magnetic induction*. The explanation of this phenomenon is that the soft iron placed

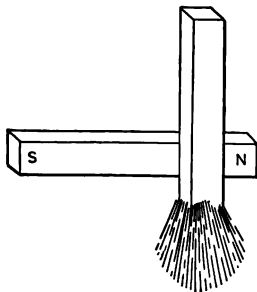

FIG. 10. — Magnetic Induction.

in the magnetic field has its molecules so arranged that the soft iron becomes a magnet. It is necessary to have the soft iron in proximity to the magnet in order that its influence may be felt, for if the magnet be removed from the soft iron, the filings will fall from the end of the soft iron bar. When the magnet has been completely removed, a small amount of magnetism remains in the bar. This effect is designated by the term *retentivity*. It is a form of molecular inertia. When the molecules of a piece of steel or soft iron are under the process of magnetization, the molecules re-

arrange themselves as described in the paragraph explaining the molecular theory of magnetism. This arrangement of the molecules becomes fixed with a piece of steel, whereas the effect is temporary with soft iron. When the steel or soft iron is removed from the influence of the magnetizing medium, there is a tendency for the new molecular arrangement to remain. It requires a certain amount of magnetizing in the opposite direction to reduce to zero the magnetism of a piece of iron once under the influence of a magnetizing force. A more complete exposition of the retentivity of soft iron is given later in treating of magnetization and hysteresis curves.

**Experiment 4.** Place a piece of soft iron in iron filings and notice that no filings are attracted to it. Place one pole of a magnet in contact with the iron bar, dip one end of the bar in filings, and notice that filings adhere to it, Fig. 10. Remove the magnet from contact with the iron bar, and notice that, while most of the iron filings fall immediately, there are still a few filings that cling to the soft iron.

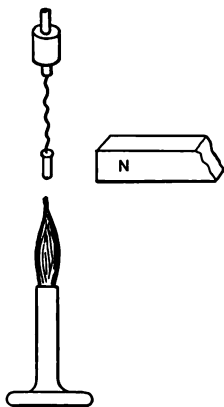

FIG. 11. — Magnetization Loss with Heat.

**Effect of Temperature upon Magnetizability.** — Temperature plays a very important part in the question of magnetizability. A magnet when heated to a dull red heat loses its magnetism to a marked degree. A small piece of iron when at red heat will not be attracted by a magnet. It is natural to suppose that if the molecular theory of magnetism be true, then when a magnet is heated and its molecules are set in vibration, they would

tend to lose their fixed position due to their magnetization.

**Experiment 5.** Mount a small wire nail upon a piece of platinum wire and suspend it from a support in a clip stand, Fig. 11. Heat the nail to redness by a Bunsen burner, and then bring a magnet into proximity to the nail, noting that the nail is not attracted to the magnet. Watch the nail cool, and notice that, as its temperature lowers, owing to the absence of the Bunsen burner, a critical temperature is reached where the nail is suddenly attracted to the magnet.

**The Effect of Vibration upon Magnetizability.** — Care should be taken in handling magnets not to allow them to suffer shocks of any kind, such as falling, since they are likely to suffer loss of magnetism from such shocks. This can be explained according to the molecular theory of magnetism on the assumption that the molecules are not permanently fixed in their new positions, and that vibration tends to allow them to return to their former positions. A small piece of iron, termed a *keeper*, Fig. 12, is commonly used to connect the north and the south poles of a magnet, forming a closed magnetic circuit. When using the magnet, the keeper should be pulled quickly from the magnet; it should not be allowed to snap back, striking the poles, but should be allowed to make the contact slowly. By carefully following these directions, it is possible, after a large number of trials, to increase the magnetism of a magnet quite perceptibly.



FIG. 12. —  
Keeper and  
Magnet.

**The Obtaining of a Hysteresis Cycle.** — When a piece of soft iron is magnetized in one direction and then the magnetizing source removed, it is found that the soft iron does not lose its magnetism *entirely*, but retains part of it.

As the iron is hardened or as it contains a greater proportion of carbon, it is found that when subjected to the same magnetizing force as before and the magnetizing force is removed, it retains a greater amount of this magnetism, becoming more and more of a permanent magnet. When steel is used, it retains considerable of its magnetism, becoming indeed a permanent magnet. In order to abstract this remaining magnetism from soft iron, or to reduce its magnetism to zero, a certain amount of energy must be used in demagnetizing it. This loss of energy, due to the *retentivity* of the iron or due to its molecular inertia, is termed *hysteresis loss*. It is not necessary to reduce the magnetism to zero in a sample of iron to have a hysteresis loss, but it is simply necessary first to increase its magnetic strength, then to lower, and then to bring it back to its original state. (See curves, Fig. 15.) Where soft iron is used and its magnetic condition is being continually changed, that is, when it is first magnetized in one direction, then in the other, the hysteresis loss may become quite a factor. In an *alternating current transformer* such a condition exists. With the modern methods of manufacture of transformer iron, involving the working of the iron through certain temperature ranges, and with the addition of certain ingredients to the iron, such as tungsten, the hysteresis loss has been reduced to a marked extent, and the *permeability* of the iron has been increased, reducing the weight of iron necessary for a given performance in a given piece of apparatus.

A curve which shows the magnetic changes in a sample of iron when carried through a *cycle* of magnetization is termed a *hysteresis curve*.

**Experiment 6.** Take an iron ring about 5 inches in diameter and  $\frac{1}{2}$  inch by 2 inches in thickness, and wind upon it about 100 turns of

No. 16 insulated wire, Fig. 13. Over this coil wind about 2 turns of wire and connect the wire to a galvanometer. It may be necessary to decrease this *secondary* coil to one turn or to increase it to 5 turns according to the sensitiveness of the galvanometer, the quality of the iron used, or the maximum deflection obtained. To the *primary* coil of a large number of turns connect a reversing switch, through an ammeter

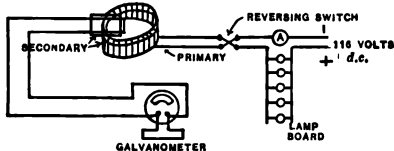

FIG. 13.—Set up for obtaining Hysteresis Curve.

and a lamp board, to a 116-volt service. The lamp board should contain two 50-candle-power lamps and three 16-candle-power lamps, which can be connected in parallel. Now close the commutating switch in one direction and then turn on all of the lamps slowly, starting with the smaller units. When ready to take observations, first turn off one 50-candle-power lamp, noting the deflection or kick of the galvanometer needle. Turn off a second 50-candle-power lamp, then a 16-candle-power lamp, a second 16, and then a third 16-candle-power lamp, in each case noting the direction and magnitude of the galvanometer deflection. Then throw the reversing switch, and turn on one 16-candle-power lamp, then the second 16-candle-power lamp, then the third 16-candle-power lamp, then a 50-candle-power lamp, and then a second 50-candle-power lamp. In each case note the deflection and the direction of the needle. Some of the readings will be small, while others will be quite large. The iron is now magnetized to a maximum value in the opposite direction to that from which it was magnetized when the experiment was started. To come back to the original starting magnetic condition, turn off one 50-candle-power lamp, then a second 50-candle-power lamp, then a 16-candle-power, a second 16-candle-power, and a third 16-candle-power lamp. Throw the reversing switch. Turn on one 16-candle-power lamp, a second 16-candle-power, a third 16-candle-power, a 50-candle-power, and a second 50-candle-power lamp. The iron has now been returned to its original state of magnetization. In coming back, all of the deflections will be in the opposite direction. (If a mistake is made in throwing the commutating switch at the wrong time, or in turning the lamps on and off at the wrong time, the experiment must be done over with the proper sequence. Be sure to have lamp sockets making a clean break.)

**How to plot the Hysteresis Curve.**—With the previous set of observations obtain a sheet of *coördinate paper*, and divide it into four quadrants. The horizontal axis, or *abscissa*, is divided up into equal

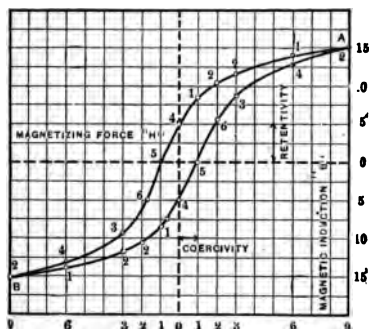

FIG. 14. Hysteresis Curve.

sections, representing usually ampere turns, but in this case representing 16-candle-power equivalents. A 50-candle-power lamp can be taken as equal to three 16-candle-power equivalents. Positions 1, 2, 3, 6, 9, to the right and to the left of the vertical zero axis indicate the respective ampere equivalents. Readings to the right of the central vertical line, *zero* or *ordinate*, indicate positive values, and readings to the left indicate negative

values. The first current value with all of the lamps turned on is line 9 to the right, or *A*. All of the deflections of the galvanometer should then be added up, that is, all positive values and all negative values going in one direction. These totals should be nearly equal. Theoretically they should be precisely equal. The readings may be tabulated for convenience as in the accompanying table, where the total is 30.

CURRENT EQUIVALENTS	+ READINGS	- READINGS
1 50 = 3 16	1	1
1 50 = 3 16	2	2
1 16	2	2
1 16	1	1
1 16	4	4
	COMMUTATE	COMMUTATE
1 16	5	5
1 16	6	6
1 16	3	3
1 50 = 3 16	4	4
1 50 = 3 16	2	2
	<hr/>	<hr/>
	30	30

Fifteen of these values are plotted above the central zero horizontal line and 15 below. A point should then be located where the horizontal line 15, above 0 abscissa, intersects with the line *A*, Fig. 14. This point is the starting point of the curve. Where line 6 intersects with

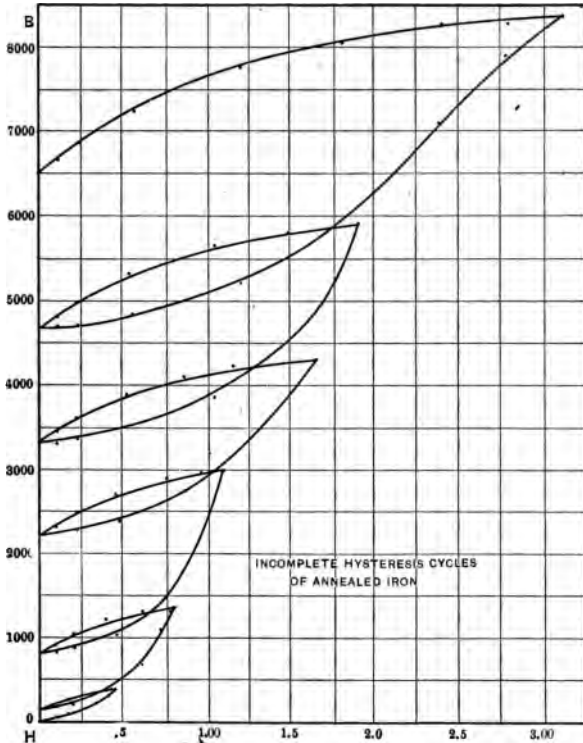

FIG. 15. — Partial Hysteresis Curves.

line 14, the second point should be located. This is obtained by subtracting deflection 1 from 15. The second point is at the intersection of line 3 with line 12, etc. The process of subtraction should be continued for the ordinates until the zero line is reached, and then the readings should be added. When one half of the curve has been plotted, the other half should be plotted in the reverse manner, starting to sub-



tract the deflections from the point *B*. In an actual test, where quantitative results are to be obtained, an ammeter is inserted in series with the lamp board or some other adjustable resistance, the length of the magnetic circuit is obtained, as well as the amperes, the constant of the galvanometer is determined, and the actual *flux density* for each *magnetizing force* is calculated.\*

**Theory of Experiment.** — Every time the current strength in the primary coil is changed, the magnetic flux in the iron changes by a certain amount. This change of flux, cutting the secondary coil, induces an elec-

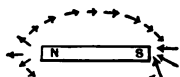

FIG. 16. — Magnetic Spectrum.



FIG. 17. — Shaker.

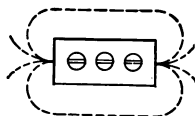

FIG. 18. — Path of Lines of Force.

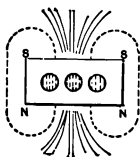

FIG. 19. — Cross Magnetization.

tro-motive force in the coil according to the laws of electro-magnetic induction (see page 46). The electro-motive force generated sends a current through the galvanometer directly proportional to the change in flux, causing a proportional throw of the needle.

**Magnetic Field.** — The space around a magnet where its influence is felt is termed a magnetic field. A compass needle moved at any point in this field sets itself parallel to the lines of force of the field.

**Experiment 7.** — Place on the condensers of a vertical lantern arranged for projection on a screen, or for laboratory work on a table, a small bar magnet. Cover this magnet with a sheet of glass and sprinkle filings over it, tap the glass, and obtain a magnetic spectrum, Fig. 1. Cover the spectrum with an additional piece of glass. In spreading the filings, a small shaker, Fig. 17, made with a fine-mesh wire netting over the bot-

\* For formulæ see Thomson's Elementary Lessons in Electricity, pages 354-363; Foster's Handbook, pages 89-93.

tom of a hole bored in wood will serve to good advantage. If the glass is tapped with a pencil after the filings have been spread upon it, the spectrum will assume the proper shape.

When the second piece of glass is in position, place a small compass needle over the glass as in Fig. 16, and move it to different points in the magnetic field. The compass needle will set itself parallel to the lines of force.

Magnets which come into contact with other magnets are likely to have consequent poles. These and other magnets, with holes in them, made from the blades of Gillette's safety razors, Fig. 18, show interesting magnetic spectrums. It is even possible to magnetize a small safety razor blade so that it will have two north poles, Fig. 19.

**A Magnet Pole travels along Lines of Force.**—The following experiment demonstrates the fact that a magnet pole free to travel will follow in its path the lines of force of a magnetic field.

**Experiment 8.**—Connect a small electro-magnet through a reversing switch and a 16-candle-power lamp in series with a 116-volt direct current circuit, Fig. 20 *a*. Over the magnet, Fig. 20 *b*, place a glass plate supporting a shallow dish containing water to a depth of  $\frac{1}{4}$  of an inch, 20 *a*. The glass dish should be as close to the magnet as possible. Through a small piece of cork about  $\frac{1}{8}$  of an inch square pass a small piece of needle which has been magnetized. Float the small magnet upon the water so that it will be in an upright position with the north pole submerged in the water. The lower pole will be attracted or repelled by whatever pole of the electro-magnet it happens to be near. It is well, before placing the dish in position over the magnet, to cover the electro-magnet

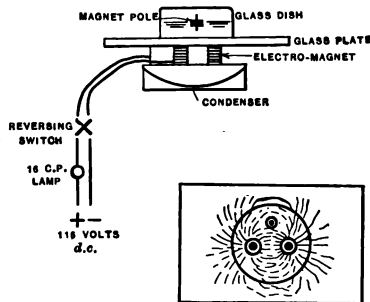

FIG. 20 *a*.—Magnet Pole travels along Lines of Force.

with a piece of glass and obtain a magnetic spectrum with iron filings so that it can be shown that the magnet pole will travel along the path of the magnetic spectrum. Place the current on the circuit, and the magnet pole will be attracted to one pole of the electro-magnet. Throw

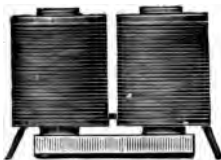

FIG. 20 b.— Small Electro-magnet.

the reversing switch, and the magnet pole will be repelled, traveling along one of the lines of the magnetic spectrum, being attracted to the other pole. When the magnetic pole is approaching the pole of the electro-magnet, if the switch is thrown, the magnet pole will continue its motion past the pole, circling around to its original starting place. It requires a little practice to throw the reversing switch at the right time. It is not well to let the magnet pole get too near the edge of the dish, since it will be attracted to the side of the dish by capillary attraction. If it looks as though this was likely to occur, throw the reversing switch, attracting the magnet back to its original pole, and then throw it again, etc. This is a lantern experiment.

**Mayer's Needles.** — The following experiment serves to illustrate the molecular theory of magnetism in showing the relation of the molecules of a sample of iron before magnetization occurs. Small magnets made from needles, as in Experiment 3, are floated

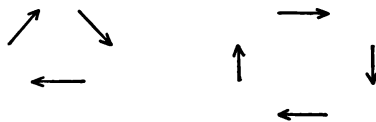

FIG. 21.— Molecular Magnets.

horizontally in a dish of water, so that their poles can be attracted to each other. After a certain time the magnets will arrange themselves in geometric figures, Fig. 21, depending upon the number present. If difficulty is experienced in preventing the magnets from being attracted to the side of the vessel by capillary attraction, a single pole of a bar magnet held over the dish or under it will serve to keep the magnets from being attracted to the side of the dish.

**Experiment 9.** Perform the experiment described, using arrangement of tank as in Experiment 8.

**Practical Application of Permanent Magnets.** — Permanent magnets are used extensively in portable and station types of ammeters and voltmeters similar to the Weston type, Figs. 22, 23, 24, 25, 26, as a means of producing load in Thomson Recording Wattmeters, Figs. 27, 28. They may also be found in nearly all tele-



FIG. 22. — Movement of Weston Standard Voltmeter.

phone receivers, Fig. 29. It is quite important that magnets used for these purposes should not change appreciably in magnetic



FIG. 23. — Weston Standard Voltmeter Complete.



FIG. 24. — Station Type of Weston Voltmeter.

strength with time. They should not only have high magnetic strength, but they should not lose this strength when used. To accomplish this, they are put through a process

of *aging*. They are subjected to certain temperature changes and to certain vibrations, so as to shake off all "loose magnetism." Permanent magnets are also used in



FIG. 25.—Laboratory Standard Weston Voltmeter.



FIG. 26.—Weston Station Type of Ammeter.

Weston Speed Tachometers and in relays, Figs. 30, 31. In the recording wattmeter a copper disc, Fig. 32, revolves between the poles of a magnet, generating *eddy currents* in the disc. The disc is equivalent to a loop of wire short-circuited upon itself, rotating in a magnetic field, generating an e. m. f. in the disc. This e. m. f. causes a current to circulate through the disc, and the current causes a counter torque or resistance to rotation, due to its magnetic field. This effect *varies directly with the speed of the meter disc* or produces a

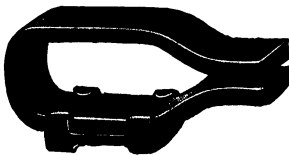

FIG. 27.—Magnets of Thomson Recording Wattmeter.

load which varies with the speed of the meter. This matter is discussed at greater length under recording wattmeters. By moving the magnets, Fig. 28, in or out so that a greater or a smaller radius for the magnetic pull may be obtained, the speed of the meter may be varied as much as 15% for a given load. This adjustment constitutes the full load adjustment of the meter.

**Ammeters and Voltmeters.** — Many types of instruments have been developed in the past for the measurement of current and electromotive force. Such instruments are termed ammeters and voltmeters. They utilized certain effects of the current, such as the attraction of a solenoid for a core of iron and the effect of temperature. Most of these instruments, however, as first constructed, were large and cumbersome; they were difficult to repair, were affected by temperature changes, were more or less inaccu-

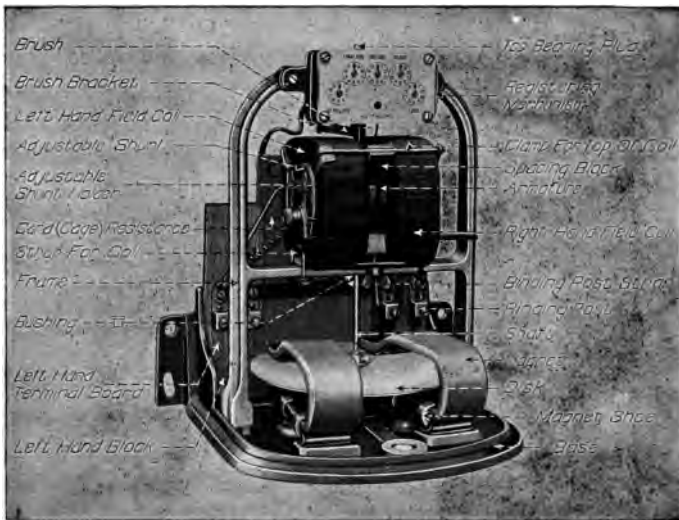

FIG. 28. — Thomson Recording Wattmeter.

rate, were not dead-beat, and required some time before the needle, or pointer, would come to rest. The development of the D'Arsonval type of instrument with permanent magnets and movable coil marked a great step in advance in instrument making. Dr. Edward Weston first developed the standard portable instrument of this type, now in com-

mon use, and this has greatly contributed toward electrical progress. Weston ammeters and voltmeters are provided with scales with uniform graduations; they are dead-beat; they are small and extremely accurate; they can be easily transported, repaired, and standardized; and they have been awarded prizes at expositions all over the world.



FIG. 29.—Telephone Receiver (M. E. S. Co.).

The fundamental principle of both the ammeter and the voltmeter is the same. The instrument, Fig. 22, consists of a powerful horseshoe magnet having curved pole pieces so as to accommodate a circular iron core and a movable coil. The magnets are carefully made of the best selected steel, so that their magnetism will be strong and permanent. Herein lies a most important feature of the instrument. A movable coil wound upon a metal shell is pivoted so that it will move freely over the circular iron core without touching the pole pieces. The

air gaps are made as small as possible, so as just to permit clearance. The small air gap serves to increase the strength of the magnetic circuit. Spiral springs are mounted on

both sides of the movable coil, top and bottom, the inner



FIG. 30.—Weston Speed Tachometers.

ends of the spirals being connected to the terminals of the movable coil in order to form one complete circuit, through which passes the electric current when the instrument is in operation. Upon the top of the movable coil is mounted a pointer consisting of a light aluminium tube which is flattened where it moves over the instrument



FIG. 32.—Wattmeter Disc.

scale, and balanced upon the other end with a counterpoise weight.



FIG. 31.—Weston Relay.

The whole moving element is very light, having practically no inertia. When the pointer is moved to one side and released, it returns to zero by means of the spiral springs which are fastened at their other extremities to movable supports. When the electric current enters and passes through the movable coil, it magnetizes this, producing poles which are repulsed by the poles of the permanent magnet, thus causing a deflection. As the permanent magnets have a constant field strength, and as the spiral springs exert a counter torque proportional to the amount of twist, the deflection of the needle is proportional to the current passing through the movable coil. The small metal shell upon which the movable coil is wound has a current circulating through it as it moves through the magnetic field of the permanent magnets. This current is due to an induced e.m.f. and opposes the *motion* of the coil, not the *deflection*. As this torque is only effective when the coil is in motion, the movable coil comes quickly to rest without any swinging of the needle. The needle will start from zero, and rise quickly as it deflects, following such changes in the current as occur with an entire absence of swinging. The amount of



current necessary to produce full scale deflection when passed through the movable coil is quite small. With a 150-volt scale with 15,000 ohms in the circuit, a current of  $\frac{1}{100}$  of an ampere flows. If the instrument is to be used



Fig. 33.—Weston Ammeter, Central Zero with Shunt.

as a voltmeter, a high resistance of about 100 ohms to the volt is placed in series with the binding posts leading from the movable coil. Thus a 3-volt scale would have about 340 ohms, and a 150-volt scale would have 16,000 ohms. The higher this resistance, the less the instrument will disturb the circuit when connected to it. Where the instrument is used as an ammeter, the movable coil is shunted by a low resistance, Fig. 33, which is placed in series with the load. This shunt may be internally connected, as in Fig. 26, or externally connected, as in Fig. 33. The form of ammeter shown in Fig. 33, with a central zero, is especially convenient for laboratory work, as it may be used without the shunt as a galvanometer. The ammeter is in reality a low range voltmeter or milli-voltmeter measuring the drop in potential across the shunt. A small mirror is mounted under the pointer of the instrument, so that when taking observations the operator looks down in the mirror and sets the reflection of the needle of the instrument on a line with the needle itself, thus eliminating parallax.

The scale may be so arranged as to indicate two sets of values, such as 150 volts and 300 volts. For details as to the calibration of voltmeter and ammeters, see chapter on measurements.

### QUESTIONS

1. Give a complete explanation of the molecular theory of magnetism.
2. How would the shapes of two hysteresis curves compare, one for a good value of soft iron, the other for annealed steel?
3. What advantage is there in using for a generator, iron with a high permeability?
4. How would you convert the flux density expressed in lines of force per square inch to lines of force per square centimeter?
5. In what direction would the north pole of a compass point if the observer were located at the north geographical pole?
6. On the assumption that magnetism cannot be insulated, how do you explain the action of the laminated sheet-iron shields, or inclosing cases, used around watches?
7. In demagnetizing a watch by placing it for a time in a coil carrying alternating current, it is often necessary to repeat the operation several times. Upon what part of the hysteresis cycle of the steel of the hairspring must the watch be taken from the coil in order that the magnetism must be zero?
8. Approximately how many times stronger would the ampere turns of the field and armature have to be if all of the iron were taken from an electrical generator? Would the electrical industry exist if it were not for the magnetic properties of iron?
9. Assuming a heavy short circuit to occur with a Thomson recording wattmeter in circuit, one which happened to be of such magnitude as to demagnetize the magnets, how would the short circuit affect the accuracy of the meter?
10. Suppose that in course of time the magnets of a voltmeter should become weakened, how would it affect the accuracy of the meter?
11. What relation does a magnetization curve bear to a hysteresis curve, and how would you plot them both together for the same sample of iron?
12. Why should the presence of iron be avoided as far as possible when using compasses or the magnet type of voltmeter and ammeter?

**13.** How would you proceed to magnetize a piece of steel with a bar magnet, if you wished to obtain a given pole at a particular end of the piece ?

**14.** Give a few examples of the use of permanent magnets not mentioned in the text.

**15.** In relays why is it sometimes necessary to place a piece of paper over the poles of the magnets to prevent the armature from sticking fast ?

**16.** Why does steel make better magnets than wrought iron ?

**17.** Why does soft iron have a smaller hysteresis loss than good steel ?

**18.** In using a mariner's compass, why is it necessary to correct the observation in order to determine the true direction of the motion of a vessel ?

**19.** Compare the earth to a magnet, showing how a compass would act when placed at various locations on its surface.

## CHAPTER II

### ELECTRO-MAGNETISM

#### THE MAGNETIC FIELD AROUND A STRAIGHT WIRE CARRYING A CURRENT

**Experiment 10.** Bore a small hole through a glass plate so that a No. 16 copper wire will pass through it, and mount the glass upon a support from which it may be quickly removed. Send a current of about 5 amperes through a wire inserted through the hole in the plate. Sprinkle the plate with filings and tap the plate. Remove the wire from plate, and note the magnetic spectrum, Fig. 34. This spectrum may be projected on a screen by placing the glass plate in the slide carrier on a vertical lantern.

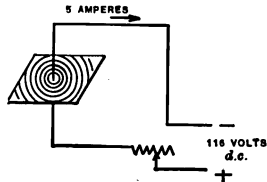

FIG. 34.—Magnetic Field around Wire.

The experiment just described proves that there is a magnetic field around a conductor carrying a current. This magnetic field is similar in all respects to the magnetic field produced by a bar magnet. This fact may be further demonstrated in the following way :



FIG. 35.—Presence of Field shown with Filings.

**Experiment 11.** Send a current of 5 amperes through a straight wire, and dip the wire in iron filings. The filings will cling to the wire, as in Fig. 35.

**Experiment 12.** Send a current of 5 amperes through a straight conductor, and place the wire first over a compass and then under a compass. Notice that the needle will deflect in both cases at right angles to the wire, and that it will point in opposite directions when above and below the wire, Fig. 36.



FIG. 36.—Field shown with Compass.

**The Compass Needle always tends to set itself Parallel to the Lines of Force.** — To determine the direction in which the needle will point, it is well to assume that one is looking along the wire from the positive end, and that

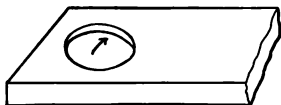

FIG. 37. — Support for Compass for Projection.

the lines of force are circling around the wire in whirls in a *clockwise* direction. The positive pole of the compass will point in the direction of the whirl, as if it were following this around.

For instance, if the current flows from a positive terminal from north to south, the compass, when placed over the wire, will point west. The letter combination S-N-O-W affords a convenient way of remembering the direction. Current passing from *South* to the *North* (+), *Over* the compass, needle will point *West*. Experiment 12 may be conveniently performed on a horizontal or a vertical lantern by mounting the compass needle in a wooden support with a hole in it, Fig. 37, and supporting it in a clip stand.

Where large cables are carrying heavy currents, such as a single 1,000,000 circular mil cable carrying 1000 amperes, the magnetic field surrounding the cable is very strong. Where such a magnetic field affects the accuracy of ammeters, voltmeters, etc., it is termed a *stray field*. Stray fields are very strong on switchboards where the *busses* behind the board carry large currents. It is sometimes necessary to install astatic instruments to eliminate the effects of stray fields.

**Experiment 13.** 1. Bend a wire back upon itself, as in Fig. 38, and send 5 amperes through it. Bring this double wire into the vicinity of a compass, and notice that the compass needle is not deflected. The current passing in opposite directions through the wire neutralizes the

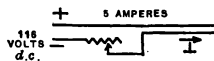

FIG. 38. — Neutralization of Magnetic Field.

magnetic field. This experiment may be performed with the lantern. A small compass may be used to test the presence of current in a cable where cables consist of one conductor; but where the cables are concentric, two in one sheath, the test is not so satisfactory. 2. Bring a flexible wire carrying a current into the vicinity of a magnet, preferably an electro-magnet. The wire should carry about ten amperes, and may be one of the leads of an electro-magnet. A flexible silk-covered wire is most suitable for this experiment. If the wire is brought near the magnet, slightly over it, and lowered quickly, it will encircle the magnet, Fig. 39.

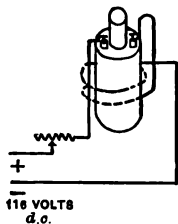

FIG. 39.—Wire carrying Current tends to encircle Magnet.

The foregoing experiment illustrates the fact that the magnetic field around a straight wire tends to adjust itself so as to assist the magnetic field of the electro-magnet, or so that its lines of force will be parallel to those of the electro-magnet.

**Effect of Current in a Coiled Wire.** — A coil of wire consisting of a number of turns of equal diameter is termed a helix.

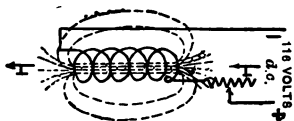

FIG. 40.—Helix.

By coiling up a length of wire in this manner, Fig. 40, and sending a current of electricity through it, it is possible to concentrate nearly all of the lines of force of all the coils so that they will have a central path through the helix.

**Experiment 14.** Bring near the opening of a helix a compass needle, and notice the poles at each end, Fig 40.

**A Large Coil for Experimental Purposes (Long Tom).** — The coil, Fig. 41, about to be described is very useful for all forms of magnetic experiments, and when supplied with an iron core becomes a strong electro-magnet. It is also useful as a variable inductance for alternating current

experiments. Such a coil, popularly known to the author's students as "Long Tom," may here be distinguished by that name for convenience. This coil is about 12 inches high and 5 inches in diameter. A hole through the center has a diameter of slightly over  $1\frac{1}{2}$  inches, so as to admit a  $1\frac{1}{2}$ -inch iron rod. In order to secure its rigidity the coil is wound upon a split brass shell with 3000 turns of No. 16 wire. It has a resistance of about 10 ohms. When connected for a short time to a 116-volt direct current circuit, and when supplied with an iron core, this coil becomes a powerful electro-magnet. It is provided with a heavy slate upper and lower base and with double binding posts.

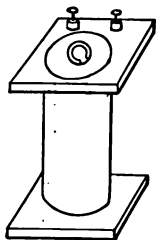

FIG. 41.—Solenoid (termed Long Tom).

**Experiment 15.** Mount a coil as just described over a support 12 inches from the floor, so that a  $1\frac{1}{2}$ -inch iron rod resting on the floor will project up into the coil about 4 inches, as in Fig. 42. Open and close a circuit of 116 volts through this coil, and the iron core will be drawn up in the coil, and will then fall, striking the floor when the circuit is broken, thus producing a trip hammer effect. When the core is suspended in the coil, catch hold of the core and lift the coil from its supports, thus showing the great strength of the magnet. By opening and closing the circuit at the right intervals, it is sometimes possible to make the core jump out of the coil.

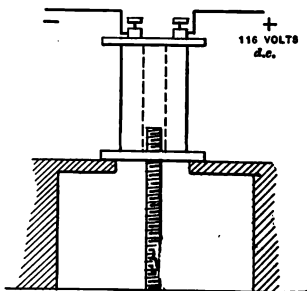

FIG. 42.—Sucking Coil.

When an iron core is drawn into a solenoid, as in the previous experiment, it is due to the fact that the core becomes magnetized by *induction*, and also because *iron in a magnetic circuit* always adjusts itself so as to accommo-

date the greatest number of lines of force. With a given magnetization 10,000 times as many lines of force may pass through a circuit of modern iron than if air alone were present. The principle of the solenoid's attracting an iron core is widely used in engineering. In railway operation, for instance, devices termed limit switches, Fig 43, consisting of a movable core actuated by a solenoid, are used to regulate the input of current into railway motors opening and closing switches which short circuit resistance. This method is also used on protective devices such as circuit breakers,



FIG. 43.—Limit Switch. (Westinghouse.)

relays, oil switches, etc. Relays are termed *straight-overload or time-limit relays*. With some types of time-limit relay, the action of the plunger of a solenoid is resisted by a small air bellows with a slight opening in it. The time taken for the plunger to force the air out in its travel is the time element in the circuit. When the plunger has finished its travel, it closes contacts which in connection with auxiliary apparatus, such as a 120-volt storage battery and the motor or solenoid on the oil switch, open the circuit. The greater the overload current, the stronger will be the attraction of the coil for the plunger and the shorter will be the time necessary to open the circuit. Relays equipped with bellows which operate in the manner described are termed *inverse time-limit relays*.

**The Electro-dynamometer.** — This instrument was employed for many years to measure alternating currents before the portable instruments now in use were developed.



The electro-dynamometer, Fig. 44, consists of two coils placed in series, one of which is movable, *AB*, and the other fixed, *CD*. When a current passes through these coils they become magnetized, repulsion of the movable coil occurring and the movable coil turning on a central axis. The motion of the movable coil is resisted by a spiral spring, and it is limited in its motion by two stops.

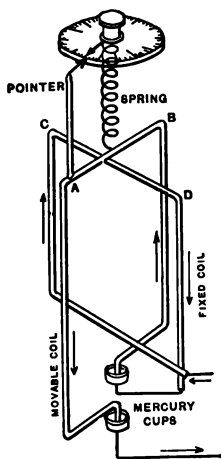

FIG. 44. — Electro-dynamometer.

By turning the spiral spring or rewinding it by a knob on the top of the instrument, the movable coil may be brought back to zero while the current is passing through it and when a deflection has occurred. The amount of twist necessary to bring the movable coil back to zero is indicated by the motion of a pointer over a dial. The magnitude of

the current that passes varies as the square root of this deflection. The value of the current is expressed in terms of a constant  $K$ , and the deflection  $\theta$ .

$$I = K \sqrt{\theta}.$$

If the direction of the current changes, the polarity of both coils will change, and the deflection will still remain the same. For this reason, as previously stated, the instrument was used for many years to measure alternating currents. At present, however, it is not being used to any great extent, as the modern portable instrument indicates the current directly without making any adjustments and without making any calculations or using any constants.

*The Effect of an Iron Core in a Helix.*

**Experiment 16.** Pass a current of electricity of about 5 amperes through a helix, as in Fig. 40, so that it will just deflect a small compass needle placed at some distance from it, say a foot. Introduce a soft iron core into the helix, and notice that the compass is attracted to a much greater degree. When the iron core is added, it becomes magnetized, its molecules arranging themselves so as to help the magnetic strength of the circuit, the combined effect of core and coil being several thousand times greater than if the coil alone were present. The core, in addition to its magnetizing effect, facilitates the passage of these lines of force. In large generators, motors, etc., and in both direct and alternating current apparatus, this characteristic of soft iron is utilized to excellent advantage. In fact, upon this characteristic the growth of the electrical industry has depended more than upon anything else. If it were necessary to take from our main generators the iron used in their construction, their efficiency would be so much reduced that the whole electrical industry would be crippled.

**Permeability, Saturation, of Iron.**— Experiment shows that the presence of an iron core in a helix increases the apparent magnetic strength of the circuit. Whether it is due to the fact that the molecular structure of the iron is rearranged, thus adding its molecular magnetism to the magnetism of the circuit, or whether it is due to the fact that the iron serves as a better conveyor of lines of force, there can be no doubt that the magnetization is greatly increased by the presence of the iron core. This characteristic of iron is termed *permeability*. It is not the same in magnitude for all kinds of iron. Some iron increases the magnetization much more than others. The permeability is not directly proportional to the magnetizing force used or to the current passing through a given winding, but varies with the previous magnetic condition of the circuit. At first, the increase in lines of force with a given magnetization is very great. Later, the curve turns at the

knee of the magnetization curve; and beyond this point, although the increase in magnetization is quite great, the increase in the number of lines of force in the circuit is quite small. In other words, the iron has become *saturated*. According to the molecular theory of magnetism, the molecules of the iron when saturated have been rotated about as far as they will go, and it requires in this condition an infinite magnetizing current to bring about the final slight increase in magnetization possible.

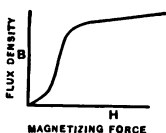

FIG. 45.—Magnetization Curve.

**Experiment 17.** Obtain a magnetization curve, using same apparatus and same set-up as in Experiment 6, except start with zero magnetization and turn on one 16-candle-power lamp, etc., up to the last 50-candle-power. For each increase of current,

throw reversing switch and obtain total change of flux. Plot curve as Fig. 45. (See footnote, Experiment 6.)

**The Electro-magnet.** — An *electro-magnet* is a helix with an iron core. Electro-magnets may have various shapes and forms, and may consist of one or more solenoids. A large coil of 3000 turns (Long Tom) when provided with an iron core will enable one to perform many interesting experiments.

**Experiment 18.** Insert the soft iron core in the electro-magnet, place a glass plate over the end of the bar, and support the magnet and plate in a vertical position. (1) Sprinkle about a pound of iron filings over the glass. The filings may be drawn out into fine threads, Fig. 46, forming a hairlike growth. When the circuit is opened the filings will fall, and when it is closed they will stand up again. This alternation may be repeated several times. (2) On placing the hand under the filings and exciting the circuit, the observer will note the strong pull of the filings. (3) Nails thrown at the magnet so that they will hit it or come near to it will be

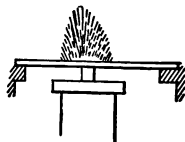

FIG. 46.—Filings showing Strength of Electro-magnet.

attracted and stand out in the direction of the magnetic field, Fig. 47. (4) A small piece of diaphragm, such as may be taken from a telephone receiver or cut from a ferrotype plate, if placed upon the end of the pole, will rise on edge, as in Fig. 48, so as to accommodate the greatest possible number of lines of force through the circuit. The piece of diaphragm



FIG. 48.—Diaphragm and Magnet.

is of more service to the magnetic circuit when upright than when flat upon the pole because it tends to decrease the reluctance of the circuit. (5) The magnetic circuit may be traced by means of a test nail

fastened to a fine thread which is held near the magnet and passed from one end of it to the other, Fig. 49. (6) The principle of the Edison ore separator may be readily shown,

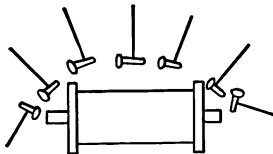

FIG. 49.—Tracing the Field.

Fig. 50, by mixing some filings with sand and allowing them to fall in a stream near the pole of the magnet; the filings will cling to the magnet to which they are attracted, whereas the sand will fall, forming a pile. Edison's apparatus was so arranged that the iron ore mixed with sand was allowed to fall down a chute. Powerful magnets diverted the iron particles to one side, whereas the sand passed on. In this way a large portion of the sand was removed, so that the remaining mixture was workable.

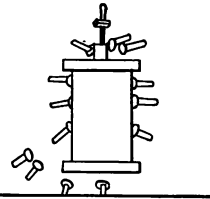

FIG. 47.—Nails showing Distribution of Flux of Magnet.

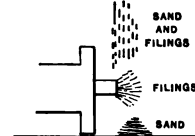

FIG. 50.—Principle of Edison Ore Separator.

**The Blow-out Magnet.**—A very important application of electro-magnetism, making use of the principle that a conductor carrying a current is attracted by any electro-magnet, is the *blow-out magnet*. When an arc is formed and maintained, the current of electricity traverses the arc through the conducting vapor, which may be metallic vapor, carbon vapor, etc. An arc, therefore, is a conduc-

tor carrying a current and also a flexible conductor, and if the arc is placed in the vicinity of the electro-magnet, it will be sucked out or blown out, depending upon the direction of the current, being quickly extinguished with a sharp snap. This principle is used in railway trolley controllers, where a hinged pole of a magnet is placed over the contact fingers to extinguish the arcs formed on opening and closing the contacts. In the case of the new types of controllers for trolley cars, and in the multiple unit control for railway operation, the main circuits are closed by contactors placed under the car.

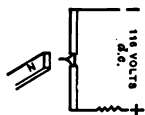

FIG. 51. — Arc extinguished with Magnet.

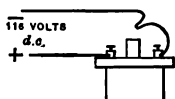

FIG. 52. — Arc extinguished with Electro-magnet.

**Experiment 19.** Place a pole of a comparatively strong bar magnet near an arc formed between two carbons, Fig. 51, and notice how quickly the arc is extinguished.

**Experiment 20.** Arrange the circuit of a large magnet so that it can be opened and closed near the pole of the magnet, as in Fig. 52. Open the circuit and notice the rapidity with which the arc is extinguished.

**Applications of Electro-magnetism.** — Among practical applications of the electro-magnet may be mentioned the field coils of motors, dynamos, parts of arc lamp mechanisms, electric bells, and relays and sounders for telegraph work. The electric bell, Figs. 53, 54, 55, consists of a small pair of magnets connected to two binding posts through a contact *A*, Fig. 55. When the circuit is closed by a spring pressing the armature against the contact *A*, the magnet draws the armature over, the clapper striking the bell.



FIG. 53. — Electric Bell (M. E. S. Co.).

This opens the circuit at *A*, and the spring returns the clapper armature to contact position again. This produces a continuous ring. A *buzzer* operates upon the same principle as the electric bell, except that the bell and clapper are removed, the sound being made by the movement of the armature. The telegraph system consists of a *line*, Fig. 56, a series of *transmission keys*, Fig. 57, and a series of magnets termed *relays*, Fig.

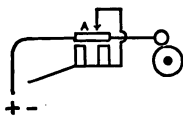

FIG. 55. — Circuit of Electric Bell.

58, all connected in circuit with a battery, as in Fig. 56. The line is grounded at both ends of a whole series of stations.

Gravity batteries are used, as the system is a closed circuit system. Operating any one of the keys will cause all of the relays on the system to draw

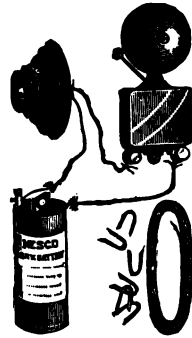

FIG. 54. — House Bell Circuit (M. E. S. Co.).

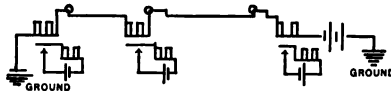

FIG. 56. — Telegraph Line.

their armatures to the poles of the magnets. In so doing, the armature closes a local circuit consisting of a battery and a sounder, Fig. 59, which intensifies the click of the relay that might otherwise be indistinguishable. The sounder is simply another pair of magnets with a heavy armature. As the current which passes



FIG. 57. — Transmission Key (M. E. S. Co.).

through all of the relays is very small, they are wound with many turns of fine wire to secure sufficient magnetic effect. The resistance of the relays is therefore great, being from 80 to 300 ohms. The resistance of the sounder is much less



FIG. 58.—Relays (M. E. S. Co.).

and may be anything from 5 to 20 ohms. To send a message the operator waits until the line is clear, and then he opens the short-circuiting switch on his key, and this opens the main line. He presses the key, making contact, and a spring returns the key when the pressure is removed. The length of time of contact may be varied, producing *dots and dashes*.



FIG. 59.—Sounder.



FIG. 60.—Electric Motor.

**The Electric Motor.** — The electric motor is discussed at great length in a subsequent chapter, so it is advisable at this point to give only a general idea of its electro-magnetic performance. An electric motor, Fig. 60, has two elements, one of which is movable and the other fixed. The movable element transmits the power and is termed the armature, Fig. 61; the fixed element is termed the field. The field circuit surrounds the armature circuit, and consists of a frame supporting an even number of poles or electro-mag-



FIG. 61. — Armature of Motor (Westinghouse).



FIG. 62. — Field Coils of Motor (Westinghouse).

nets, Fig. 62. All electric motors possess two elements, whether they are of the alternating current type or the direct current type. A direct current is one which con-





FIG. 63.— Induction Motor  
(G. E. Co.).

tinues to flow in the same direction once it has established itself, whereas an alternating current is one which is continually reversing its direction of flow with a regular periodicity. With an alternating current motor, it may be that the rotating element, or rotor, *A*, Fig. 63, consists simply of a number of copper bars assembled around the periphery of a circular core in slots, and short-circuited at its extremities. An alternating current motor employing such a rotating element is termed an *induction motor* (see chapter on induction motor). There are two types of direct current motor in common use, the *shunt* and the *series* motor (see subsequent chapters). Modifications of these two types are the *compound motor* and the *interpole motor*. The armature of a direct current motor consists of an iron core made up of laminated sheets of iron mounted upon a spider perpendicular to the shaft. In the perimeter of this core are slots in which are placed the armature conductors. The terminals of the armature coils are

connected to copper segments insulated from each other with mica, constituting the commutator, Fig. 64. The coils are wound upon the armature so as to form the proper magnetic circuits when a current is sent into the commutator by means of the brushes. There are many forms of armature windings which have been developed by various designers, and to these the reader is referred. The simplest of all



FIG. 64.—Commutator (Westinghouse).

is the common series winding illustrated in Fig. 65. This consists of one or more sets of coils connected in parallel between adjacent commutator segments to form a closed series winding. When the current enters the armature and field circuits, they become magnetized, forming poles and causing rotation. See Fig. 66 for magnetic circuits. The brushes are made of carbon or copper, carbon being preferable. The substitution of the carbon brush

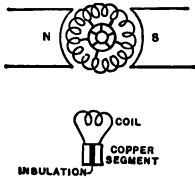

FIG. 65.—Series Winding.

for the copper brush was a great step forward in electric railway operation and did much towards establishing electric railroading on a substantial basis. As the armature rotates, the commutator moves under the brushes, and this maintains the same relative magnetic relations of armature and field. The direction of the current in the coil undergoing commutation changes at the same time.

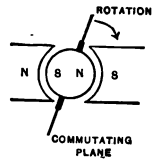

FIG. 66.—Rotation of Armature.

In the shunt motor the armature and field coils are in multiple with each other, Fig 67, whereas in the series motor the coils are in series with each other, Fig. 68. The armature of a direct current motor is usually represented by a small circle with two brushes pressing upon it, —○—, the

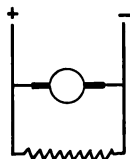

FIG. 67. — Shunt.

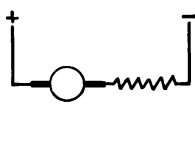

FIG. 68. — Series.

field circuit being represented by the wave , Fig. 69. A shunt motor is used for constant speed work, whereas a series motor is used for variable speed operation. The shunt motor need not necessarily be rigidly connected to its load, whereas this is a necessity with the



FIG. 69. — Armature and Field Symbols.

series motor. The series motor exerts its greatest tractive

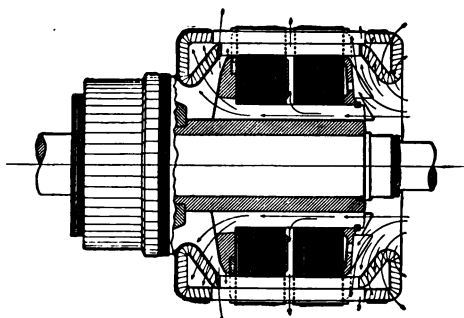

FIG. 70. — Cross Section of Armature (Westinghouse).

force when starting, and is therefore particularly service-

able for elevator and railway operation. Should the load of a series motor become detached from it, as by a belt slipping off the motor pulley, there is danger of the motor

armature's damaging itself by the speed of rotation becoming excessive.

A cross section of an armature of a Westinghouse shunt motor is shown in Fig. 70.

**Thomson Inclined Coil Ammeters and Voltmeters.** — The Thomson inclined coil voltmeters and wattmeters operate on the dynamometer principle, whereas the Thomson ammeters operate on the magnetic vane principle. This consists of a single solenoid mounted at a slight angle. With the ammeters, Figs. 71, 72, a small iron vane is mounted at the same angle as the solenoid upon a vertical bronze shaft, which terminates in polished sapphire jewel bearings. When turned, the vane enters more and more into the solenoid, until its axis becomes parallel to the central axis of the coil. A pointer attached to the axle moves over a graduated scale as the vane turns. The vane turns when the coil is energized, as the iron vane tends to enter more and more into the magnetic field of the coil to help accommodate the

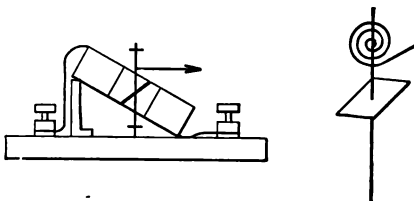

FIG. 71. — Thomson Inclined Coil Ammeters.



FIG. 72. — Thomson Inclined Coil Ammeter.

lines of force passing through it. A flat spiral spring of highly tempered phosphor-bronze, mounted upon the axle, returns the needle to zero position after a deflection. The swinging of the needle is reduced to a minimum by an air vane damper mounted under the pointer and fastened to the axle. Excessive oscillation of the needle may be

resisted by a friction damping device operated by a small push button. The whole instrument, Fig. 72, is quite light and is inclosed in a gun-metal case; owing to its lack of permanent magnets it retains its calibration over a considerable period and is not so likely to be affected by stray fields. The instrument is not affected to any extent by variation of frequency, wave form, or power factor. It lacks, however, the dead-beat characteristic of a permanent magnet type of instrument.

The Thomson inclined coil voltmeter is similar in construction to the ammeter, except that an inclined coil is substituted for the metal vane, the meter acting on the dynamometer principle.

**Thomson Inclined Coil Wattmeter.** — This instrument has two coils — a fixed low resistance coil, and a movable high resistance potential coil which is mounted inside of the current coil. Both coils are inclined as in the inclined

coil ammeter. When energized, the movable potential coil tends to set itself parallel to the current coil. The other structural features are similar to those of the ammeter and voltmeter.



FIG. 73.— Weston Wattmeter Movement.

**Weston Indicating Wattmeter.** — In this type of instrument, Fig. 73, there are two coils, one fixed, the other movable; the movable coil turns inside of the fixed coil at right angles to it. The fixed coil or current coil has a low resistance and is connected to two binding posts which are placed in series



FIG. 74. — Tractive Magnet built by Cutler Hammer Clutch Co

with the circuit when used. The movable coil, or potential coil, has a high resistance and is connected through two spiral springs to two other binding posts, which are placed in multiple with the consuming device whose energy consumption is being measured. The instrument is very accurate and operates on the dynamometer principle, but does not possess the dead-beat characteristic of other types of Weston instruments.

**Traction Electro-magnets.** — An extensive use of electro-magnets for tractive purposes is being developed at the present day by some companies, notably the Cutler Hammer Co. One of these magnets is shown in Fig. 74, where pig iron is being unloaded from a car.

#### QUESTIONS

1. How does an electro-magnet differ from a permanent magnet; and in what respect are they similar?
2. Of what advantage is the iron core of an electro-magnet, and to what extent does it affect the apparent strength of the magnet? Can you explain this phenomenon?
3. Why is an electro-magnet consisting of two solenoids preferable to one solenoid?
4. What do we mean by the terms magnetizing force and flux density?
5. Give a sketch showing how you would determine the polarity of a solenoid if you knew the direction of the winding and the direction of the current through it?
6. How would you proceed to magnetize a piece of steel with a solenoid?
7. Describe the principle of operation of the Weston alternating current ammeter, wattmeter, and the Thomson inclined coil ammeter of the General Electric Co.
8. Which will make the stronger solenoid, 100 turns of wire with 1 ampere passing through it, or 10 turns of wire with 10 amperes passing through it? Is there any difference approximately?

**9.** Why is the iron plunger of a solenoid drawn up into the solenoid when the coil is energized?

**10.** Give a few practical illustrations of electro-magnets, and explain their function.

**11.** If the winding of a solenoid were partially short-circuited and the current passing through it was the same as before the short circuit occurred, how would it affect the strength of the solenoid?



## CHAPTER III

### ELECTRO-MAGNETIC INDUCTION—THEORY OF THE DYNAMO

IN 1831 Michael Faraday discovered the principle of electro-magnetic induction. He noticed that if a loop of

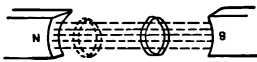

FIG. 75. — Method of generating Zero E. M. F.

wire is moved in a magnetic field so as to cut the lines of force of that field, a current of electricity circulates in the coil, due to an electro-motive force induced in it. If the wire is moved in a direction parallel to the lines of force as in Fig. 75, no e. m. f. is induced in the loop, as the wire must *cut* the lines of force. A loop of wire thrown loosely over a cylinder, as in Fig. 76, would represent a loop of wire in a magnetic

field, but the lines of force would not be

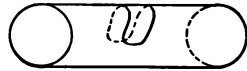

FIG 76. — Lines of Force not Interlinked.

field, but the lines of force would not be *interlinked with* the loop.

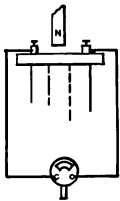

FIG. 77.— Generating an E. M. F.

**Experiment 21.** Take a large coil having many turns (Long Tom) and connect this coil to a galvanometer. Quickly plunge a bar magnet into the coil, Fig. 77, and notice that the galvanometer needle deflects. Notice also that the deflection occurs only when the magnet is in motion. Move the magnet in very slowly, and notice that practically no deflection occurs. Move the magnet in very quickly, and notice that the deflection becomes very great. Notice also that when the magnet is extracted from the coil, the deflection of the galvanometer is in the opposite direction from that when the magnet is moving into the coil. Move the magnet

into and out of the coil, causing the galvanometer needle to deflect, first in one direction, and then in the other, thus *generating an alternating e.m.f.*

**Experiment 22.** Connect a coil of many turns (Long Tom) to a constant source of potential, the 116-volt Edison service, Fig. 78. Connect a long wire which can be wound up in a coil of 20 loops to a galvanometer. With but a single loop, equivalent to a straight conductor, move the wire across the top of the coil so as to cut the lines of force emanating from the pole, and notice deflection of galvanometer.

**Experiment 23.** Repeat all of the previous experiments with the coil as with the magnet, the excited coil taking the place of the permanent magnet, and notice that the results are similar. Notice the effect of speed and the direction of the moving coil.

**Experiment 24.** Increase the number of turns in the loop to 2, 4, 8, 10, etc., moving coils of the loop across the excited large coil, maintaining the speed of motion about the same in each case, and notice that the deflection of the galvanometer needle is proportional to the number of turns.

**Experiment 25.** Insert a resistance in series with a coil of such magnitude that the current passing through the coil will be cut down to one half, and compare the magnitude of deflection for the same speed of motion of the coil for 5 turns in this case, with the same number of turns in the previous case. The deflection in this case will be approximately one half of that in the former, as the magnetic strength of the solenoid has been reduced to one half.

**Generation of an Electro-motive Force.** — From the previous experiments it will be noted that the magnitude of the electro-motive force generated by moving a coil in a magnetic field varies with the speed of motion, with the number of turns in the coil, and with the strength of the magnetic field. If a magnetic field of a certain number of lines of force of say 100,000,000 be cut by a single loop of wire in 1 second, 1 volt will be generated in the wire. If this field be cut in  $\frac{1}{2}$  second by the single loop, 2 volts will be gener-

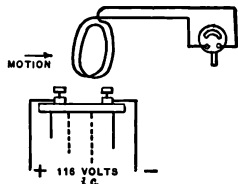

FIG. 78. — Generating an E. M. F.

ated. If it be cut by 2 turns in 2 seconds, 1 volt will be generated. If the field strength be reduced to 50,000,000 lines of force and they be cut by 1 turn in 1 second,  $\frac{1}{2}$  volt will be generated. The electro-motive force or voltage generated varies directly as the total number of lines of force cut in one second. When 100,000,000, usually designated as  $10^8$ , called 10 to the 8th power, lines of force are cut in 1 second, 1 volt is generated. This relation is conveniently expressed in the simple form :

$$E = \frac{\phi \times N \times S}{10^8}$$

Where  $E$  = e. m. f. in volts,

$S$  = revolutions of coil per second,

$N$  = number of turns in loop,

$\phi$  = total number of lines of force.

This is for a two-pole machine. For any other number of pairs of poles the e. m. f. will be directly proportional to the number of pairs of poles. A dynamo electric machine used to generate an electric current is termed a *generator*.



FIG. 79. — Rotary Converter (G. E. Co.).

**Generators.** — A direct current generator is almost identical in construction with a direct current motor. If the armature of a shunt motor be driven by an external force and the

field winding be separately excited, an electro-motive force will be generated, and the motor will be operating as a generator. A number of generators have been built in which about two volts per foot of active conductor are generated. It is well to remember that the electro-motive force which is generated in the winding of any electrical generator is *alternating in character* and that this electro-motive force in



FIG. 80. — Motor Generator (Westinghouse).

order to be *direct* must be rectified by a commutator. If two slip rings are connected to the windings at two points directly opposite to each other on a two-pole machine, an *alternating current generator* will result. A machine may be constructed with a commutator on one end of the armature and slip rings on the other end. Such a machine, when driven and when its field coil is excited, will yield direct current at the commutator and alternating current at the slip rings, being what is known as a *double current generator*. A double current generator may be operated as a motor on its direct current side and would supply alternating current at the alternating current slip rings. It would be termed an *inverted rotary converter*. A rotary converter

is usually operated from an alternating current source of supply on the alternating current side and delivers



FIG. 81.— Motor Generator (G. E. Co.).

direct current at the commutator side, being thus a *normal rotary converter*, Fig. 79, or *synchronous converter*. If the double current generator be supplied with two separate windings with the same field, each winding having a separate commutator connected to different number of armature turns, such as five times as many turns on one armature winding as the other, the machine can be operated as a motor from one winding, yielding a pressure five times as great from the other armature winding. Such a machine is called a *dynamotor*. Where the windings each have separate field coils, the machine is called a *motor generator*, Figs. 80, 81, 82. If two generators be operated in a series parallel combination, on a three-

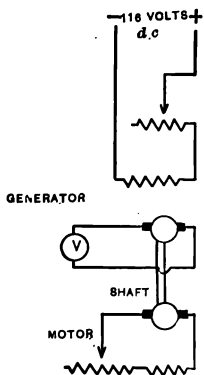

FIG. 82.— Circuit of Motor Generator.

wire system as in Fig. 83, they tend to balance the system and are termed *balancers*. The machine on the heavier-loaded side acts as a generator, while the machine on the light-loaded side acts as a motor.

**Variation of E. M. F. of Generator.** — The e. m. f. of a generator may be varied by increasing its speed of rotation, or by increasing the number of armature conductors in series, or by increasing the field excitation. Increasing the field excitation by decreasing resistance in series with it, as in Fig. 84, is the customary method used in practice.

**Experiment 26.** Take a small motor generator and separately excite the generator field coils through a field rheostat, Fig. 82. Have a rheostat also connected in series with the field coils of the driving motor so that the speed of the motor may be varied. Connect a projecting voltmeter or an ordinary voltmeter across the armature terminals so that the voltage generated will be indicated. Vary speed of motor, noting speed with speed indicator. Note that the *voltage generated varies directly as the speed*. Vary the excitation of the generator by varying the field rheostat of the generator, and note that the voltage generated varies with the excitation, but not quite directly. Motor is not connected to mains in cut.

### *Magnetization Curve of a Shunt Dynamo.*

**Experiment 27.** With a set-up similar to that in the last experiment, keep the speed of the generator constant. Vary the excitation of the generator from zero to maximum and then back to zero, reading the voltage generated and also the current passing through the field circuit. An ammeter should be placed in series with the field circuit. In taking observations be careful to make the steps of the rheostat adjustment continuous. If one finds that one has moved the rheostat handle too

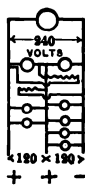

FIG. 83. — Balancers.

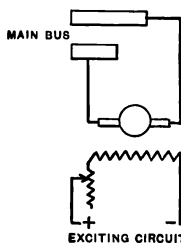

FIG. 84. — Field Circuit of Generator.

far, do not move it back and then forward, since by so doing an imperfect curve will result, due to residual magnetism. From this experiment a curve will be obtained, Fig. 85. It will be noted that the descending curve lies above the ascending curve. This is due to *residual magnetism*.

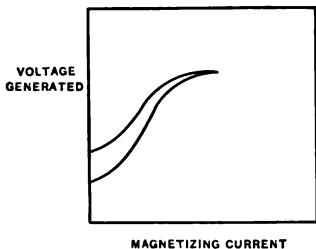

FIG. 85. — Magnetization Curve.

field and armature circuits. Small soft iron wires may be made highly magnetic by twisting them in a lathe until they become hardened and break.

**Residual Magnetism.** — Residual magnetism is a natural magnetic condition of iron which appears to be present in most manufactured sheets used in building up the *laminated*

**Experiment 28.** Connect a voltmeter to the armature terminals of a small generator, Fig. 86. Disconnect the field terminals and do not excite field circuit. Drive the armature of the generator and notice that, although there is no exciting current present, a voltage of about 5 volts will be generated. This e. m. f. is generated owing to the residual magnetism of the iron.

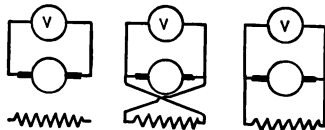

FIG. 86. — Excitation of Generator.

**Experiment 29.** With the same set-up as before connect the armature and field circuits together to form a shunt connection, Fig. 86, and start the generator operating. Field terminals should be so connected that the machine will not *build up*. If it does build up, reverse the field terminals as in Fig. 86. When this connection is made it will be noted that the previous reading of 5 volts will be reduced to 3 volts or thereabouts. The 5 volts previously generated tend to send a very small current through the field circuit in the wrong direction. This small current tends to demagnetize, or “knock out,” the residual magnetism. If it were possible to reduce entirely this 5 volts to zero, it would obviously leave no residual magnetism to build up on the other side of zero.

**Experiment 30.** Make the proper field connection to the armature, and note that voltage builds up.

**Experiment 31.** With the dynamo field circuit connected so that it will not build up, change the direction of rotation, and note that the machine does build up, — why?

The relation of direction of rotation to the building up of the field circuit is made use of to excellent advantage in some railway electric car lighting systems as used by steam roads. Instead of changing the field terminals when the direction of motion of the car changes, the brush holders are so mounted that they will be carried forward or backward from one neutral plane to the other by the friction of the brushes, their motion being limited by two stops. Irrespective of the direction of motion of the car, the armature and field terminals of the generators always have the proper connection for building up. This system is used by the Bliss Car Lighting Company.

**Mutual Induction.** — When an electro-motive force is generated in a coil by the presence of a magnetic field produced by another coil, the effect is termed mutual induction. In order that the effect of one coil may be felt upon the other coil, the lines of force must be interlinked with it.

**Experiment 32.** Place a magnet in a large coil (Long Tom), and connect the coil to a galvanometer. Allow a small piece of diaphragm, Fig. 87, to come into contact with the magnet and then suddenly draw the diaphragm away from the magnet. A deflection of the galvanometer will occur, due to a change in the magnetic condition of the circuit. Mutual induction is present in transformers.

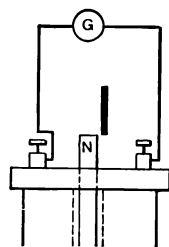

FIG. 87. — Principle of Induction.

**Foucault Currents.** — A copper disc, Fig. 88, rotated between the poles of a permanent magnet has an electro-motive



force induced in it and is equivalent to a straight wire carrying a current. This electro-motive force causes a current to circulate in the disc, and the current produces a magnetic field which tends to resist rotation. Such currents are called *Foucault or eddy currents*. The reason

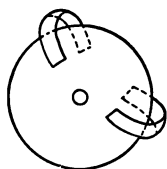

FIG. 88.—Wattmeter Disc with Magnets.

that it is necessary to laminate armatures of dynamos and motors is to reduce to a minimum the circulation of these eddy currents. The currents circulate parallel to the shaft of the armature, and tend to heat the armature circuit. A small coating of shellac on the ordinary laminations, or the hard surface coating which is being formed on modern laminated iron is sufficient to insulate these currents and reduce the loss to a very small amount.

**Experiment 33.** Connect a pair of small electro-magnets to a few batteries so that the magnets will be strongly magnetized. Suspend a small piece of sheet copper, such as may be cut from the copper electrodes of a gravity cell, so that the copper disc can swing back and forth between the poles of the magnet. With the magnets excited, notice that if the copper strip is drawn to one side and released, Fig. 89, it will be suddenly arrested in its motion as it tends to pass the poles of the magnet.

**Experiment 34.** Cut another strip from the same sheet of copper of the same dimensions and slit the strip with staggered cuts, as in Fig. 90, so as to insulate the path of the eddy currents. Suspend this piece in place of the strip used in the previous experiment, excite the magnets, draw piece to one side, release it, and notice that it *does not stop* in its motion past the magnets. (Both of these experiments are readily adaptable to a horizontal lantern.)

**Application of Foucault Currents.** — One of the greatest practical applications of foucault currents is in the Thomson Recording Wattmeter, Fig. 28. In this instrument the magnets are mounted in the base of the wattmeter, so

that a disc can move between them. This disc, either of copper or aluminium, has *eddy currents* generated in it which act as a *drag* or load upon the meter, the load being directly proportional to the speed of rotation of the meter. In calibrating the wattmeter it may be that the meter is either fast or slow. By moving the magnets in or out over the disc, a variation of 15% in the

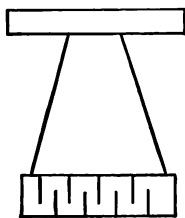

FIG. 90. — Insulation of Eddy Currents.

meter speed may be made. In installing such meters, care must be taken to see that they are not affected by *stray* fields of other circuits near by.

A heavy short circuit in the meter also tends to affect the magnets, sometimes strengthening one pole of a magnet and decreasing the strength of the other pole. Although the motor type of meter presents a few of these difficulties, it is found in practice that when properly maintained and inspected such a meter is very accurate and gives practically no trouble. See chapter on recording wattmeters for further description.

**Practical Applications of Induction.** — Many practical applications of induction exist in transmission systems. We have the induction coil, Figs. 91, 92, consisting of a primary and a secondary winding, the primary circuit having an interrupted current sent through it. The induction coil is used extensively in telephone circuits, Fig. 93, and in wireless telegraph circuits, Fig. 94. The principle of the wireless circuit is indicated in Fig. 94, where a coherer is

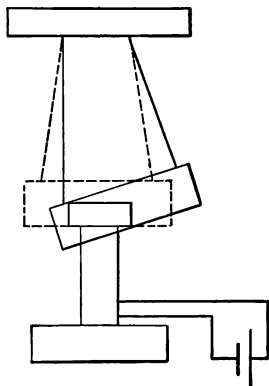

FIG. 89. — Principle of Eddy Currents.

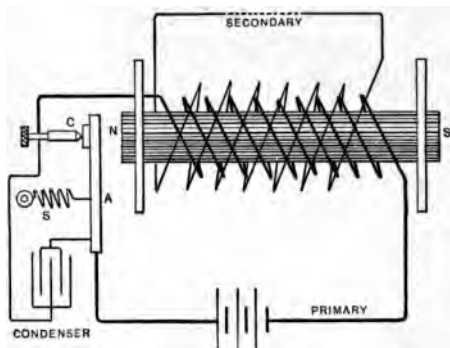

FIG. 91.—Ruhmkorff Coil.



FIG. 92.—Shocking Coil.

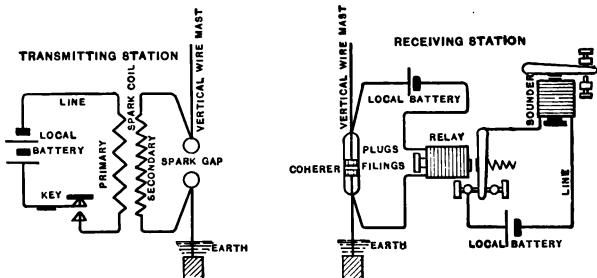
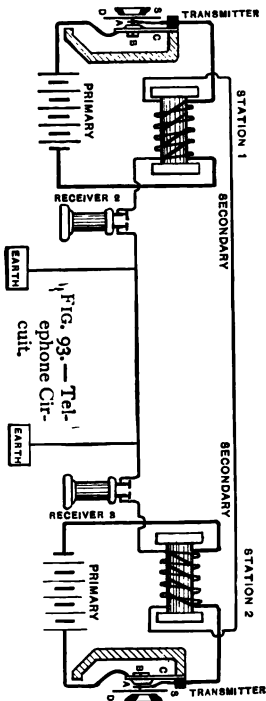

FIG. 94.—Wireless Circuit.



FIG. 95. — Wireless Sending Apparatus.

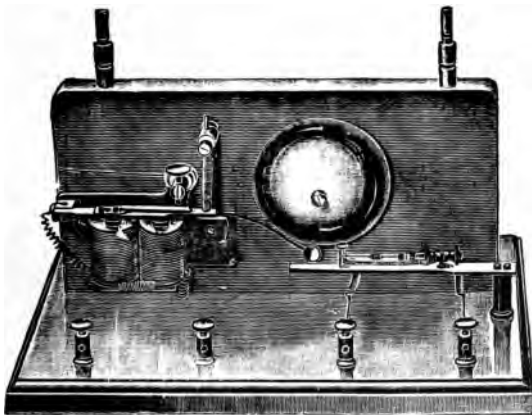

FIG. 96. — Wireless Receiving Apparatus.

shown which consists of two small pellets inclosed in a tube containing nickel filings. Ordinarily the circuit shunt-



FIG. 97.—Desk Telephone.

ing the coherer is interrupted, but when a wave is sent out from the sending stations, the particles of nickel stick together, closing the shunt circuit. When this happens, an armature is drawn up, striking a bell, and also the coherer tube, giving a signal and also interrupting the circuit. The large commercial sets, such as used by the Marconi Company, are more complicated than the simple apparatus shown in Figs. 95, 96.

This apparatus, however, is good for experimental purposes and may be purchased from O. T. Louis Co., 59 Fifth Ave., New York City. A convenient form of telephone, termed a desk telephone, is shown in Fig. 97. The various circuits shown are self-explanatory.

#### QUESTIONS

1. Who discovered the principle of electro-magnetic induction ?
2. What does the term *eddy currents* mean ?
3. Explain the action of eddy currents in a wattmeter disc and show how temperature changes in the disc affect the meter's accuracy.
4. What is the object of laminating dynamo electro machines ?
5. Cite some examples of where the magnetic field due to one wire has affected the operation of a circuit in the vicinity.
6. Explain the theory of the generation of electro-motive forces.
7. Why are pole dampers placed on the pole faces of rotary converters and alternating current generating apparatus ?
8. How does the principle of induction enter into the operation of a transformer ?
9. How can a resistance be wound so that it will be non-inductive ?
10. Show how induction may be likened to inertia.

## CHAPTER IV

### OHM'S LAW

IN dealing with a direct current circuit the terms *electro-motive force*, *current*, and *resistance* are frequently met with. Each of these terms has a unit, a symbol, and a measuring instrument associated with it. They may all be tabulated as follows :

Term	Unit	Symbol	Measuring Instrument
Electro-motive Force	Volt	$E$	Voltmeter
Current . . . . .	Ampere	$I$	Ammeter
Resistance . . . . .	Ohm	$R$	Ohmmeter*

**Resistance.** — Resistance may be discussed first, as it is most readily understood. Resistance may be defined as an opposing force which has to be overcome in order to cause a flow of electrical energy. In so doing a certain amount of energy is continuously transformed into heat by the resistance so long as the flow of electrical energy continues. The amount of energy dissipated by the resistance in the form of heat is proportional to the time the energy is flowing, and to the magnitude of the current which is passing in the circuit. Resistance in an electrical circuit is somewhat analogous to the resistance of water pipes to the pas-

\* In measuring resistance there are many other methods used besides the ohmmeter, as may be noted in the chapter on Electrical Measurements, the ohmmeter being used infrequently.

sage of water. The greater the length of the conductor, the greater is the resistance, and the greater the cross section of the conductor, the less is the resistance. The energy dissipated by the resistance is usually in the form of heat, although it may be accompanied by a transformation into mechanical energy or into radiant energy in the form of light. The symbol " $R$ " is usually used to designate resistance and also the wave  $\sim\sim\sim$ . An adjustable resistance has a movable contact placed on the wave  $\sim\sim\sim$ . The unit of



FIG. 98. — Car Resistance.

resistance is the *ohm*. Numerically it is equal to the resistance of a uniform column of mercury 106.3 centimeters long, weighing 14.4521 grams in mass, at 0° centigrade. Some idea of the dimension of the resistance may be had from the following :

1. A 16-candle-power 116-volt carbon lamp has a resistance cold of approximately 500 ohms, and when hot a resistance of 250 ohms.
2. The resistance of 1000 feet of copper wire No. 10, B. & S. gauge, is approximately one ohm at 20° C. (See wire table.)

3. A graphite stick 10 inches long by  $\frac{1}{4}$  inch in diameter may have a resistance as high as 700,000 ohms.\*

4. A cable such as is used by electric light companies for underground distribution may have a resistance, when first installed, of 250 megohms; a megohm is a million ohms (insulation resistance).

5. The human body has a resistance of from 1000 to 10,000 ohms. Most of this resistance is due to the skin of the body.

A large size resistance but of low value is shown in Fig. 98.

From the above list it will be noted that no idea can be gained of the magnitude of a resistance from its size, color, or other physical characteristics.

**Circular Mil.** — In resistance calculations the term *circular mil* applied to the cross section of a wire, frequently appears. The *circular mil* is a small circle having a diameter of *one mil*, that is,  $\frac{1}{1000}$  of an inch. Care should be taken not to confuse the term *mils* with circular mils. If the diameter of a wire is known in thousandths of an inch, its cross section may be obtained in circular mils by squaring this quantity. For instance, a cable with a diameter of 1 inch would have one thousand one-thousandths of an inch

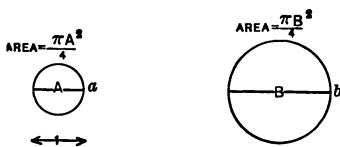

FIG. 99. — Circular Mil.

$(\frac{1000}{1000})$ ; squaring the 1000, or multiplying ( $1000 \times 1000 = 1,000,000$ ), we obtain 1,000,000 circular mils. A one million circular mil cable when bare of insulation has a diameter of one inch. The reason why the diameter in mils squared gives the area in circular mils may be understood by considering the areas of two circles, Fig. 99, *a* and *b*, whose diameters are *A* and *B*.

Let  $A = \frac{1}{1000}$  of an inch, or equal to 1 mil, in which case

\* Convenient resistances made of graphite can be purchased from the Dixon Crucible Co., of New York, for about 18 cents. Their resistance varies from 1000 to 700,000 ohms. They are small in size and are quite useful for experimental work.



the area of the circle "a" equals the unit according to definition, one circular mil. The area of any circle is expressed as being  $\pi$ , 3.1416, times the diameter squared divided by 4 or area of  $a = \frac{\pi A^2}{4}$  and area of  $b = \frac{\pi B^2}{4}$ .

How many times does the circular mil "a" go into the area "b"? Dividing one area by the other, we obtain

$$\frac{\frac{\pi B^2}{4}}{\frac{\pi A^2}{4}} = \frac{\cancel{\pi} B^2}{\cancel{\pi} A^2} \times \frac{\cancel{4}}{\cancel{4}} = \frac{B^2}{A^2}$$

or the areas vary as the squares of their respective diameter.

Substituting in  $\frac{B^2}{A^2}$ , for  $A$  its value 1, we obtain  $A^2$  or  $A \times A$

$= 1 \times 1 = 1$ , or  $\frac{B^2}{1} = B^2$ . The area  $b$  is then  $B^2$  times

greater than  $a$ , which is one circular mil. The area of  $b$  in circular mils is then equal to its diameter  $B$  in mils squared.

**Resistance of Copper Conductors.**—The resistance of copper wire or cables having a circular cross section may be readily calculated from the formula,

$$\text{resistance} = \frac{10.35 \times \text{length in feet}}{\text{cross section in circular mils}}$$

This formula is true for copper wire at 98 % purity, Matthiessen standard at 68° F.

This formula expresses the fact that *one mil foot* of copper has a resistance of 10.35 ohms at 68° F.

The sum  $R$  of resistances  $r_1$  and  $r_2$  placed in series is expressed as follows:

$$R = r_1 + r_2.$$

When placed in parallel they are expressed in the following form:

$$\frac{1}{R} = \frac{1}{r^1} + \frac{1}{r^2}$$

$$r^1 r^2 = R(r^1 + r^2)$$

$$R = \frac{r^1 r^2}{r^1 + r^2}$$

**Temperature Coefficient.** — Most pure metals increase their resistance with an increase in temperature, although some substances, such as carbon, decrease their resistance with an increase of temperature. Some alloys are manufactured, such as Ia Ia wire, Krupp resistance wire, Superior wire, etc., with very low *temperature coefficients*, slight changes with increase in resistance. For pure copper and most pure metals the temperature coefficient is .0042 per ohm per degree centigrade above zero. If  $R_0$  be the resistance of any wire at zero, then  $.0042 \times t \times R_0$  would be the change for temperature  $t$  of the wire, and  $R_0(1 + .0042 t)$  would be the resistance  $R_t$  at temperature  $t$ .

$$R_t = R_0(1 + .0042 t).$$

The wire table on pages 64 and 65 shows the resistance of various sizes of copper wire at various temperatures. For the larger sizes of cables the formulæ for resistance and temperature coefficients should be used.

**Electro-motive Force.** — The electro-motive force usually expressed in *volts* is the pressure which forces the electricity through the circuit. It is sometimes compared to water pressure. In a dynamo electric machine the volts generated depend upon the number of lines of force cut in one second. When 100,000,000 ( $10^8$ ) lines of force are cut in one second, *one volt* is generated. If 200,000,000 lines of force be cut in one second, two volts are generated. *Voltage may be defined as the rate of cutting of lines of force.* An electro-motive force or a voltage may be gen-

COPPER WIRE TABLE OF AMERICAN INSTITUTE OF ELECTRICAL ENGINEERS

Giving weights and lengths of cool, warm, and hot wires, of Matthiessen's standard of conductivity

DIAM-ETER A.W.G.	Inches	AREA		LBS. PER FOOT	LBS. PER OHM			FEET PER LB.	FEET PER OHM		
		Circular mils	Sq. in. Sq. mils		@ 20° C.	@ 50° C.	@ 80° C.		@ 20° C.	@ 50° C.	@ 80° C.
0000	0.460		166,100	0.6405	13,000	11,720	10,570	1,501	25,440	18,200	16,510
000	0.406		131,700	0.5080	8,232	7,360	6,647	1,069	16,210	14,510	13,000
00	0.3648		104,98	0.4028	5,177	4,034	4,182	2,482	12,850	11,500	10,380
0	0.3240		82,887	0.3195	3,250	2,614	2,630	3,130	10,100	9,123	8,232
1	0.2863		65,732	0.2533	2,048	1,833	1,654	3,047	8,083	7,235	6,528
2	0.2570		52,128	0.2009	1,288	1,153	1,040	4,077	6,410	5,738	5,177
3	0.2294		41,330	0.1593	810.0	725.0	654.2	6,276	5,084	4,550	4,100
4	0.2043		32,784	0.1264	509.4	455.9	411.4	7,014	4,031	3,608	3,256
5	0.1810		25,099	0.1002	320.4	286.7	258.7	9,080	3,197	2,862	2,582
6	0.1620		20,618	0.07946	201.5	180.3	162.7	12,58	2,535	2,269	2,048
7	0.1443		16,351	0.6302	126.7	113.4	102.3	15,87	2,011	1,800	1,624
8	0.1285		12,067	0.04908	70.60	71.33	64.36	20.01	1,595	1,427	1,288
9	0.1144		10,283	0.03603	50.12	44.86	40.48	25.23	1,265	1,132	1,021
10	0.1010		8,155	0.03143	31.52	28.21	25.46	31.82	1,003	897.6	800.0
11	0.09074		6,467	0.02493	19.82	17.74	16.01	40.12	795.3	711.8	642.3
12	0.08081		5,129	0.01977	12.47	11.10	10.07	50.50	636.7	504.5	460.4
13	0.07106		4,067	0.01508	7.840	7.017	6.332	63.70	500.1	447.7	404.0
14	0.06468		3,225	0.01243	4.931	4.413	3.982	80.44	390.6	355.0	320.3
15	0.05797		2,558	0.009858	3.101	2.776	2.504	101.4	314.5	281.5	254.0
16	0.5082		2,029	0.007818	1.950	1.746	1.575	127.0	249.4	223.3	201.5
17	0.4526		1,603	0.006200	1.226	1.098	0.9906	161.3	197.8	177.1	159.8
18	0.4030		1,276	0.004917	0.7713	0.6904	0.6230	203.4	156.9	140.4	126.7
19	0.3580		1,012	0.003809	0.4851	0.4342	0.3918	256.5	124.4	111.4	100.5
20	0.3106		802	0.003002	0.3051	0.2731	0.2464	323.4	98.66	88.31	70.68
21	0.2846		636.3	0.002452	0.1919	0.1717	0.1550	407.8	78.24	70.93	63.10

22	0.02535	642.4	504.6	0.001045	0.1207	0.1080	0.00746	514.2	62.05	55.54	50.11
23	0.02257	500.5	400.2	0.001542	0.07580	0.06703	0.06120	648.4	40.21	44.04	30.74
24	0.02010	404.0	317.3	0.001223	0.04773	0.04272	0.03855	817.6	30.02	34.93	31.52
25	0.01790	320.4	251.7	0.0009699	0.03688	0.03687	0.02424	1.031	30.95	27.70	24.69
26	0.01594	254.1	190.6	0.0007092	0.01888	0.01690	0.01528	1.300	19.40	21.97	15.82
27	0.0142	201.5	158.3	0.0005100	0.01187	0.01093	0.009588	1.639	15.43	17.42	15.72
28	0.01264	159.8	125.5	0.0004837	0.007406	0.006083	0.006030	2.007	12.24	13.82	12.47
29	0.01126	126.7	99.53	0.0003836	0.004096	0.004203	0.003752	2.607	10.66	10.96	9.886
30	0.01003	100.5	78.94	0.0003042	0.002953	0.002643	0.002385	3.287	9.707	8.688	7.840
31	0.008928	79.70	62.60	0.0002413	0.001857	0.001662	0.001500	4.145	7.698	6.800	6.217
32	0.007950	63.21	49.64	0.0001913	0.001168	0.001045	0.0009436	5.227	6.105	5.464	4.930
33	0.007080	50.13	39.37	0.0001517	0.0007346	0.0006575	0.0005933	6.501	4.841	4.333	3.910
34	0.006305	39.75	31.22	0.0001203	0.0004620	0.0004135	0.0003731	8.311	3.830	3.436	3.101
35	0.005615	31.52	24.76	0.00009543	0.0002995	0.0002601	0.0002347	10.480	3.045	2.725	2.450
36	0.005050	25.85	19.64	0.00007568	0.0001827	0.0001636	0.0001476	13.210	2.414	2.161	1.950
37	0.004453	19.83	15.57	0.00006001	0.0001149	0.0001029	0.00009281	16.660	1.915	1.714	1.547
38	0.003905	15.72	12.35	0.00004759	0.00007210	0.00006044	0.00005824	21.010	1.519	1.359	1.220
39	0.003531	12.47	9.70	0.00003774	0.00005445	0.00004608	0.00003971	26.500	1.204	1.078	0.9720
40	0.003145	9.888	7.77	0.00002903	0.00003858	0.00003559	0.00002309	33.410	0.9550	0.8548	0.7713

The data from which this table has been computed are as follows: Matthiessen's standard resistivity, Matthiessen's temperature coefficient, specific gravity of copper = 8.80. Resistance in terms of the international ohm.

Matthiessen's standard 1 meter-gram of hard drawn copper = 0.1469 B. A. U. @ 0° C. Ratio of resistivity hard to soft copper 1.0226.

" " " soft " = 0.14365 B. A. U. @ 0° C. One B. A. U. = 0.9866 international ohms.

Temperature coefficients of resistance for 20° C., 50° C., and 80° C., 1.07908; 1.26025, and 1.33681, respectively. 1 foot = 0.3048028 meter, 1 pound = 453.59240 grams.

Although the entries in the table are carried to the fourth significant digit, the computations have been carried to at least five figures. The last digit is therefore correct to within half a unit, representing an arithmetical degree of accuracy of at least one part in two thousand. The diameters of the B. & S. or A. W. G. wires are obtained from the geometrical series in which No. 0000 = 0.4600 inch and No. 30 = 0.005 inch, the nearest fourth significant digit being retained in the areas and diameters so deduced.

It is to be observed that while Matthiessen's standard of resistivity may be permanently recognized, the temperature coefficient of its variation which he introduced, and which is here used, may in future undergo slight revision.

F. B. CROCKER, W. E. CEVEY,  
G. A. HAMILTON, A. E. KENNELLY, Chairman, } "Units and Standards,"  
Committee on

erated by chemical action, as in a battery. These volts are identical with those generated by a dynamo, although their manner of production is different. The voltage of a generator is expressed by the product of the number of armature turns, the field flux and the speed, divided by  $10^8$ . Varying either of these three quantities will change the magnitude of the electro-motive force.

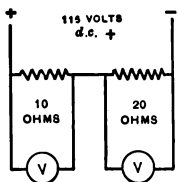

FIG. 100. — Principle of Distribution of Potential.

For convenience the term electro-motive force is referred to as *e. m. f.* When an *e. m. f.* is forcing a current of electricity through a series circuit, each ohm requires the same pressure. As in Fig. 100, if one part of a circuit has twice the resistance of the other part of the circuit, it will have twice the potential difference across its

terminals. This leads to the conclusion :

*That the distribution of potential in a series direct current circuit is always proportional to the resistance of the elements.*

**Standard Cells.** — There are two types of standard cells which are in use extensively in this country, that which is known as the Carhart-Clark cell, Fig. 101, and that which is known as the Weston Cadmium Cell, Figs. 102 *a*, 102 *b*. At the International Electrical Congress, held in Chicago, in 1893, the following resolution was passed by the committee on standards concerning the unit of electro-motive force :

It was resolved that as a unit of electro-motive force, the international volt be used; this is the *e. m. f.* that, steadily applied to a conductor whose



FIG. 101. — Carhart-Clark Cell.

resistance is one international ohm, will produce a current of one international ampere, and which is represented sufficiently well for practical use by  $\frac{1000}{134}$  of the e. m. f. between



FIG. 102 *a*. — Weston Cell.

the poles or electrodes of the voltaic cell known as Clark's cell at a temperature of  $15^{\circ}$  C. and prepared in the manner described in the accompanying specifications.

The Clark cell, sold commercially as the Carhart-Clark cell, Fig. 101, has for its positive element mercury and its negative element amalgamated zinc, the electrolytes being a saturated solution of sulphate of zinc and mercurous sulphate. With the Carhart-Clark cell, the zinc sulphate solution is saturated at  $0^{\circ}\text{C}$ ., instead of at  $15^{\circ}\text{C}$ ., the temperature coefficient being only half as great, and the e. m. f. 1.440 volts. With the Clark cell, the e. m. f. is 1.434 international volts. The cell is provided with a small thermometer, its e. m. f. for any temperature being calculated from the following formula:

$$E = 1.4328 - 0.00119(t - 15^{\circ}\text{C}.) - 0.000007(t - 15^{\circ}\text{C}.)^2$$

The Weston Cadmium cell has as elements cadmium and mercury, the electrolytes being the sulphate of cadmium and mercury.



FIG. 102 *b*.—Weston Cell.

For details of specification, see Foster's Handbook, pages 10-13.

In this cell, as made by Dr. Weston, the cadmium sulphate solution is saturated at  $4^{\circ}\text{C}$ , resulting in practically a zero temperature coefficient.

The e. m. f. of the cell is 1.01985 international volts, and it will remain constant provided current not in excess of .0001 ampere is used from the cell. In other words, a resistance less than 10,000 ohms should never be connected

across the terminals of the cell.\* The method employed by the various manufacturing companies in this country and the Reichsanstalt in Germany is to make up at one time a large number of these cells and check them against each other from time to time. The cells are usually made with insulated binding posts, so that in handling them the fingers of the operator will not come into contact with the bare parts of both terminals at the same time, as in this event a resistance of about 2000 ohms would be placed in series with the cell. This value, 2000 ohms, for the resistance of the hand is only approximate, as it is a widely variable quantity, depending upon the contact made and depending also upon the individual. The writer has found persons whose bodily resistance as measured from hand to hand varied from 1500 to 10,000 ohms.

The standard cell is a very important instrument to use in connection with potentiometers for checking voltmeters and ammeters. Details for doing this are given in the chapter on Electrical Measurement. Two standard cells may be checked against each other by means of a potentiometer, and this is the method usually followed in practice. The late Professor Carhart devoted many years of his life to the development of the Carhart-Clark cell.

**Current.**—The term *current* of electricity is usually defined in terms of its effect on the circuit. A current of one ampere is one which :

- (1) When passed through a solution of silver chloride will deposit in one second .0011181 grams of silver on the negative pole.
- (2) When passed through a wire bent in the form of an arc of one centimeter radius, of one centimeter of

\* It sometimes becomes necessary to use a resistance less than 10,000 ohms, in which event the circuit should be closed for only a short instant.



length, will exert a force of one tenth of a dyne on a unit magnet pole placed at its center. The absolute unit of current is 10 times as great, in which case the force would be 1 dyne.

- (3) When passed through a resistance of one ohm will develop .24 gram-calories of heat per second.
- (4) Will be forced through a resistance of one ohm by a pressure of one volt.

Definition 4 is the accepted one as recommended by the Standardization Committee of the American Institute of Electrical Engineers.

Some idea of the dimensions of the ampere may be gained from the following :

One 16-candle-power carbon filament lamp takes .43 ampere.

One 1,000,000-circular-mil cable, one inch in diameter, will carry 1000 amperes without heating excessively.

One 40-horsepower motor such as is used in a 4-motor trolley car may take 200 amperes at starting.

One 8-car heavy subway train or an electric locomotive such as is used by the New York Central and Hudson River R. R. may take 3000 amperes at starting.

An inclosed arc lamp such as is used for illuminating the New York City streets takes about 4.5 amperes.

A flaming arc lamp may take as high as 12 amperes.

A projecting lantern usually uses about 15 amperes in its arc.

An incandescent lighting circuit is not supposed to carry more than 6 amperes per outlet. A standard resistance box containing low resistances should not have more than .4 ampere pass through any of the low resistances and preferably less than this. A direct current of .1 ampere passed through the human body

has been known to be fatal. A telephone receiver can detect a current as low as  $\frac{1}{100,000}$  of an ampere by its click.

A better conception of the idea of current can perhaps be gained by considering two conductors, one carrying a current twice that carried by the other. Suppose one is looking at the cross section of both of these conductors and that one can count at any instant of time the number of "electrons," or charged carriers of electricity, which are passing the section of both conductors under consideration, it is quite probable that one would count twice as many of these electrons in one case as in the other. Current is defined by some beginners as the *quantity* of electricity which passes through a circuit per unit of time. This definition is incorrect, as the quantity of electricity per unit of time or the *ampere second* is defined by the unit *coulomb* (one ampere flowing for one second is the coulomb). Current has but one dimension, a cross section as it were, and neither length nor time.

**Ohm's Law.\*** — Dr. Simon Ohm, in 1826, formulated a law which exhibits the relation of electro-motive force, current, and resistance. With a thorough grasp of the application of Ohm's law, any problem in direct currents may be readily solved. The same relation of the quantities composing Ohm's law, namely electro-motive force, resistance, and current, also applies in the alternating current circuit; but two other factors appear here and must be considered, namely, inductance and capacity. These factors are also present in the direct current circuit, but they only affect the

\* This law was first stated in his "Bestimmung des Gesetzes, nach welchem die Metalle die Kontaktelektrizität leiten," 1826, and was developed and proved mathematically in his "Die galvanische Kette mathematisch bearbeitet," 1827.

circuit when a change in the current flow is taking place. For instance, the inductive effect of a field of a direct current generator may be so great that one second will elapse after closing the circuit before the current reaches its maximum value. This can be demonstrated by closing and opening the field circuit of a 10-kw. machine. If the switch is closed and opened quickly, only a small spark occurs. If the interval of its remaining closed be slightly increased, the arc on opening the circuit will increase. After the switch has been closed for several seconds and is then opened, the arc will be very much increased.

*Ohm's law may be expressed as follows: In any direct current circuit containing resistance, the current in amperes which is passing through this resistance will always be equal to the difference of potential across this resistance, measured in volts, divided by the value of the resistance of the circuit, expressed in ohms.*

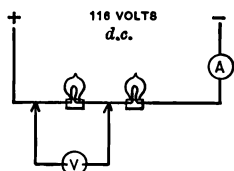

FIG. 103. — Ohm's Law.

**Experiment 35.** Take a 116-volt circuit, place two 16-candle-power lamps in series with a 2-ampere ammeter and the circuit, Fig. 103, and measure the difference in potential across each lamp with a voltmeter. Calculate the resistance of the lamp when the circuit is closed.

If  $E$  be used to designate the difference of potential in volts,  $R$  to express the resistance in ohms, and  $I$  the current in amperes, then,

$$I = \frac{E}{R}.$$

For many years the letter  $C$  was used to designate current, but the capital  $I$  is now used exclusively for this purpose,  $C$  being used to designate capacity. A convenient

way of remembering the relation of the quantities in Ohm's law is offered by the following form :

$$\frac{E}{I \times R} = 1.$$

If in a given circuit we know any two of these quantities, we can find the third from the relation mentioned above. For instance, if we wish to know the resistance  $R$  of the circuit, and we know the electro-motive force  $E$  and the current  $I$ , place the finger over the  $R$  in the above formula, and we have the result  $R = \frac{E}{I}$ . To obtain the value of the electro-motive force when the current and resistance are known, place the finger over the  $E$ , and we obtain  $E = I \times R$ . The practical interpretation of Ohm's law is that when a circuit is once formed, the electro-motive force always sends a maximum of current through the circuit. When the current is passing through the circuit, each ohm requires the same pressure in volts to force the current through it. If we had a resistance of 100 ohms connected across a circuit of 116 volts, we would have a current of  $\frac{116}{100} = 1.16$  amperes passing through the resistance, and each ohm would require 1.16 volts to force this current through it. If we should measure part of such a resistance, with a voltmeter so as to include 50 ohms, it would indicate on the voltmeter 58 volts. An interesting consequence of such an experiment is that *the distribution of potential is proportional to the resistance*. If two unequal resistances, such as 20 ohms and 100 ohms, be placed in series with a 120-volt circuit, the potential will distribute itself proportionally to their respective resistances, 20 volts being the difference of potential across the 20 ohms, and 100 volts the potential difference across the 100 ohms, or

$$e : e' :: R : R',$$

$$20 : 100 :: 20 : 100,$$

where  $e$  and  $e'$  are the two e. m. f's and  $R$  and  $R'$  are their respective resistances.

An interesting case of the application of this principle of the distribution of potential in a circuit is that of the Brush direct current series arc circuit, each circuit containing 50 lamps of 40 volts difference of potential, connected in series, and making a total potential of 2000 volts. There are three of these 2000-volt circuits to a machine which may be connected in series, making 6000 volts. Although there is only 40 volts difference of potential to each lamp, yet if the circuit is opened at any lamp, the potential across the gap rises to 6000 volts, the resistance of the air gap being greater than that of the entire circuit. Some idea of the resistance of an air gap may be obtained when it is stated that it requires 20,000 volts to jump a one-inch air gap. Where there is danger of coming into contact with a high voltage circuit, it must be realized that quite possibly the circuit may be partially grounded at one or more points. This is a condition likely to occur especially with overhead wires, whose insulation deteriorates quite rapidly the first year after installation. Suppose a person to be standing on the ground touching a *live* wire which had sagged. Suppose also the circuit to be grounded at some other point. The difference of potential across the complete grounded circuit including the person would be equal to the sum of the differences of potential of the lamps included between the two points.

**Example.** — If a series arc circuit of 40 volts per lamp were grounded at a certain point, and a person whose bodily resistance was 8000 ohms were standing on the ground, the soil and his shoes being damp,

making contact, 20 lamps from the point where the line was grounded, how much current would pass through his body? *Answer*: approximately  $\frac{1}{10}$  ampere.

One reason why it is not desirable to operate an ordinary call bell on a 116-volt circuit with a lamp in series to cut down the current is that every time the armature of the bell moves over, opening the circuit, an arc is produced which corresponds to a 116-volt circuit. The magnitude of the arc is always proportional to the potential of the circuit. It is possible to open a direct current circuit of 200 amperes and 2 volts with a very small switch, whereas if the voltage were 500 volts and the current 10 amperes, a much heavier arc would be formed.

Where it is desirable to operate a low voltage device, such as a motor or an electric bell, from a 116-volt circuit, a resistance may be connected across the service, and part of this resistance may be shunted off to the consuming device, as in Fig. 104.

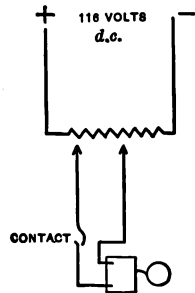

FIG. 104. Method of obtaining Low Voltage.

### QUESTIONS

1. A carbon filament lamp consumes 3.1 watts per candle power; a tantalum lamp, 2 watts per candle power; and a tungsten lamp, 1.25 watts per candle power. What would be the wattage and current consumption of these lamps if of 16 candle and burned on a 118-volt circuit? *Answer*: watts, 49.6, 32, 20.0; ampere, .42, .27, .17.

2. An arc lamp used in a projecting lantern on a 118-volt circuit, has a potential of 40 volts across the arc and 15 amperes passing through the lamp. What is the value in ohms of the resistance placed in series with the arc? *Answer*: 5.2 ohms. If the resistance of the arc changes so that the current falls to 10 amperes, what will be the potential across the resistance? *Answer*: 52 volts.

3. In a series arc circuit of 6000 volts, containing 50 volts to the lamp, the line becomes grounded at a certain point, making a ground whose

resistance is 1000 ohms. A man having a bodily resistance of 5000 ohms grounded makes contact with the arc circuit, 60 lamps from the grounded point. What current will pass through his body, assuming his contact resistance is practically zero. *Answer* : .5 ampere, which would be sufficient to kill if the contact were sufficiently long.

4. A dry battery having a normal voltage of 1.5 volts is short-circuited on an ammeter having a negligible resistance. The ammeter indicates 10 amperes. What is the internal resistance of the battery? *Answer* : .15 ohms.

5. If a storage battery of 2 volts having an internal resistance of .01 ohms be short-circuited, what current will flow? *Answer* : 200 amperes.

6. A dynamo generating 120 volts, uncompounded, has its voltage fall to 110 volts when supplying 100 amperes of load. What is the equivalent resistance of the armature circuit? *Answer* : 0.10 ohm.

## CHAPTER V

### PRIMARY AND STORAGE BATTERIES

IN 1786 Galvani, a physician of Bologna, noticed that, when he suspended a pair of frog's legs on a window hook, the legs twitched. He supposed that an electric current was generated by the frog's legs; whereas the twitching, as noticed later by Volta (a professor in the University of Pavia), was due to the two dissimilar metals, such as an iron hook and a copper window frame, being brought into contact, and the nerves of the frog's legs being excited by the electricity generated at the junction.

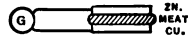

FIG. 105. — Galvani's Experiment.

**Experiment 36.** Place a small piece of meat in contact between two dissimilar metals such as copper and zinc, and connect the two metals to a sensitive galvanometer, Fig. 105. Note deflection of the galvanometer.

**The Simple Cell.** — The *simple cell*, consisting of two dissimilar metals placed in an electrolyte, was first developed by Volta. When the terminals of such a cell are brought into contact, an electric current flows through the circuit, as indicated in Fig. 106.

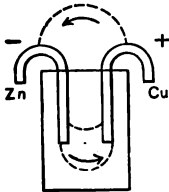

FIG. 106. — Voltaic Cell.

**Experiment 37.** Place a strip of zinc and a piece of copper, Fig. 106, in a vessel containing dilute sulphuric acid (1 part of acid to 20 of water). Notice that, if the zinc is not *amalgamated*, or coated



with mercury, the zinc slowly dissolves into solution. Make a contact between the copper and the zinc electrodes, and notice that bubbles begin to rise from the copper electrode. Open the circuit, and notice that the bubbles cease to rise from the copper plate. Such a cell is termed a voltaic cell.

On connecting the terminals of such a cell to a voltmeter, it will be noticed that the copper is *positive* and the zinc terminal *negative*, the potential of the cell being about 1.05 volts. When the circuit is closed, the current passes in the external circuit from copper to zinc and in the solution from zinc to copper, forming a circuit. The metal plates suspended in the liquid are termed *electrodes*, and the conducting solution is termed an *electrolyte*.

**Note.** An experimental tank, Fig. 107, for projecting purposes to be used on a horizontal lantern can be made by taking two pieces of  $\times \frac{3}{8}$ " plate glass, 4"  $\times$  5", and separating them by a piece of rubber gas tubing bent in the form of a U. The tank may be held together by two clamps made from thin cedar, held together by 8-32 machine screws.

FIG. 107.—  
Projecting  
Tank.  
The advantage of a simple tank of this kind is that it may be readily taken apart and cleaned, and that liquids can remain in it for some time. Such a tank, indeed, is superior in every way, except perhaps in appearance, to one that is cemented.

**Chemical Action of Cell.**—When the simple cell is in operation, the current, passing through the sulphuric acid solution,  $H_2SO_4$ , gradually electrolyzes it, splitting it up into its components,  $H_2$ , or two parts of *hydrogen*, and  $SO_4$ , or *sulphion*. The  $SO_4$  has a very strong affinity for zinc, combining with it and forming  $ZnSO_4$ , or *zinc sulphate*, leaving free the hydrogen gas, which rises at the copper electrode. The reaction is expressed as follows :

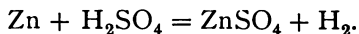

A number of cells placed in series, the positive of one cell connected to the negative of the other cell, form a *battery*. Volta was one of the first to discover the cumulative action.

**The E. M. F. of Cells.** — Any two dissimilar metals immersed in an acid solution constitute a cell. The potential, or electro-motive force, of such a cell is independent of the size of the electrodes. Changing the *electrolyte* of the cell will affect the electro-motive force, and changing the character of the electrodes will also affect the potential. The metals arrange themselves in a definite series: —

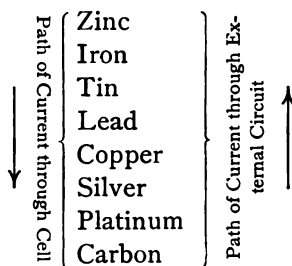

### *Effect of changing Electrodes.*

**Experiment 38.** Connect a projecting galvanometer, having a low resistance in series with it so as to make a voltmeter of it, to a wooden support in which are two holes containing mercury, Fig. 108, into which the galvanometer wires dip.

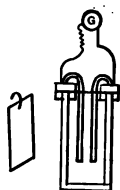

FIG. 109. — Support in Position.

Have a number of various electrodes, such as zinc, iron, tin, lead, copper, platinum, and carbon, Fig. 109, which have curved terminals that can fit also in the mercury cups. Mount two electrodes, copper and zinc, in a tank, Fig. 109, containing dilute sulphuric acid. Place various combinations of electrodes in the tank, and notice magnitude and direction of deflection. Zinc and lead will cause a deflection in one direction, lead

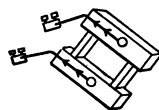

FIG. 108. — Support for Electrodes.

being positive to the zinc. Copper substituted for the zinc will cause a deflection in the opposite direction, copper being positive to the lead. Substitute zinc for the lead, and the deflection will be in the same direction, but still greater. Carbon and zinc afford about the greatest deflection and are used extensively in practice, as both are comparatively cheap. The Mesco dry battery, the Leclanché cell, the Grenet cell, and the Bunsen cell all employ this combination of elements.

### *Effect of changing Electrolytes.*

**Experiment 39.** Repeat the previous experiment, using the same electrodes, such as zinc and copper, but change the electrolyte, using instead a solution of salt, of soapsuds, etc. The e. m. f. values will change for the different solutions.

From the two preceding experiments it would seem that a suitable cell could be made from any two dissimilar metals immersed in any electrolyte. While it is true that a cell could be produced in this manner, it would not be suitable for commercial work, owing to various transformations which occur in the cell while operating. This matter will be discussed later. Electrolytes, in the first place, must be acid solutions, so that they will attack one electrode more readily than the other; they further must not disintegrate in themselves. When bubbles of hydrogen gas are developed in the cell, they form a coating on one of the electrodes which tends to insulate the cell and also to change its polarity. This effect is termed *polarization*.



FIG. 110. — Polarization Tank.

### *Polarization.*

**Experiment 40.** Place a zinc and copper electrode in a solution of  $H_2SO_4$  so that but a small part of the electrodes is immersed; connect the terminals of the electrodes to an electric bell. Notice that after a time the intensity of ring of the bell decreases, until finally the bell armature ceases to

move. Heat the electrodes over a bunsen burner, and repeat the experiment, showing the effects of polarization. The heat of the flame will drive off the polarizing gas.

**Experiment 41.** Repeat the experiment, substituting a low-range voltmeter for the bell, and notice that the deflection of the voltmeter will be great at first and will then gradually fall as the battery polarizes.

**Depolarizers.** — Various substances are used as depolarizers in batteries, such as manganese in the Leclanché cell, and bromide of potash in the Grenet cell. In the carbon cell, Fig. 111, the carbon electrode has a large surface to decrease the polarizing effect. The action of the depolarizing element is to absorb the hydrogen gas developed at the positive electrode and so prevent this polarizing action. What might be termed chemical depolarizers, like manganese, can only be employed for cells upon intermittent work, such as call bells.



FIG. 111.— Carbon Cell.

For continuous duty or closed circuit work, such as fire alarm systems, telegraph systems, etc., another method of depolarizing is employed in which two fluids are used in the cell, the principle of electrolysis being utilized.

**Experiment 42.** Fill a large-sized vessel full of water. Add a few drops of permanganate of potash solution, coloring the water a deep wine color. Dissolve in another vessel a few crystals of "hypo," used for photographic work. Add a few drops of the hypo solution to the colored potash solution, stirring the liquid with a glass rod. The action of the permanganate solution is so strong that the liquid will quickly lose its red color and become clear. This illustrates the action of a depolarizer. If the liquid becomes milky instead of clear add a few drops of  $H_2SO_4$  beforehand.

**Electrolytic Depolarizers.** — A two-fluid cell contains two electrolytes separated either by gravity or by a porous cup, the electrodes projecting each in the separate solutions.

The Daniell cell, the gravity cell, and the Grove cells are of this type. With the Daniell cell a zinc electrode projects in a porous cup containing a dilute solution of sulphuric acid,  $H_2SO_4$ , and a copper electrode projects in a saturated solution of copper sulphate,  $CuSO_4$ . When the cell is in action the zinc has a strong affinity for the acid radical  $SO_4$  in the  $H_2SO_4$ , combining with it, and leaving two molecules of hydrogen,  $H_2$ , forming zinc sulphate,  $ZnSO_4$ . The free hydrogen,  $H_2$ , has a strong affinity for the  $SO_4$  of the  $CuSO_4$  solution, forming  $H_2SO_4$ , leaving the free copper, which is deposited electrolytically upon the copper electrode. The reaction may be written as follows:

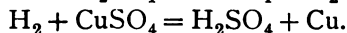
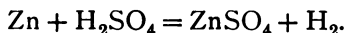

**Electrolytic Condensers.** — An interesting use is made of the effects of polarization in a device termed an electrolytic condenser, Fig. 112. The electrolytic condenser consists of two ordinary lead plates immersed in a vessel containing dilute sulphuric acid. The two electrodes are connected up through a suitable resistance, such as a 50-candle-power lamp, to a source of constant potential, such as a 116-volt direct current Edison service. When so connected, the

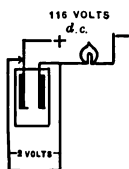

FIG. 112.— Electrolytic Condenser.

cell will yield a potential of about 2 volts. Terminals may be led off from the battery when so connected to a bell circuit, a plating bath circuit, or any other apparatus where a low constant voltage is required. An electrolytic condenser circuit is preferable to the 116-volt circuit with resistance in series. This eliminates the arc which is produced when the 116-volt circuit is

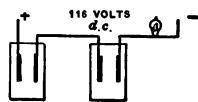

FIG. 113.— Electrolytic Cells in Series.

opened. The arc formed for the same amperage varies with the potential of the circuit. A number of cells may be placed in series, Fig. 113, yielding any potential desired. This apparatus is quite economical in energy consumption.

**Experiment 43.** Take two lead strips and suspend in a dish of dilute sulphuric acid, and then charge for an instant through a 16-candle-power lamp in series with a 116-volt direct current circuit. Open the circuit and connect the terminals of plates to a galvanometer, noting the kick.

**Experiment 44.** Connect an electrolytic tank in series with a 16-candle-power lamp and a 116-volt circuit, and shunt off from the condenser to an electric bell. Change 16-candle-power lamp to 32-candle-power, and to 50-candle-power, noting the effect on the bell.

When an electric current passes through an electrolytic condenser, it decomposes the liquid, forming gas at the electrodes, oxygen and hydrogen resulting. These two gases, being formed at the electrodes, create the potential.

**Closed Circuit Cells.**—Cells intended for continuous operation, such as fire alarm and telegraph systems, are termed closed circuit cells. The term *battery* is frequently used in speaking of a single *cell*, but this usage is improper, as a battery implies a number of cells. Closed circuit cells are usually of the two-fluid type, have a high internal resistance, give a small current on short circuit, and when once set up must have a constant load, whether the load be real or artificial. If the load on the cell be removed, the liquids are likely to mix.

**Daniell Cell.**—This cell, as stated on page 82, consists of a porous cup containing a zinc electrode immersed in a dilute sulphuric acid solution. The porous cup is suspended in a vessel containing a saturated solution of copper sulphate surrounded with a copper electrode. After a time it is necessary to replenish the liquid, as the copper sulphate becomes weak as a result of having had the

metallic copper taken from it. The sulphuric acid also becomes zinc sulphate. The cell has a remarkably constant potential of 1.178 volts with 1 in 12 acid and is used by some investigators as a sub-standard cell.

**Experiment 45.** Set up a Daniell cell, taking care to amalgamate the zinc.

**Local Action.** — Most commercial zinc contains impurities such as iron. When a zinc electrode is suspended in a cell, the iron and the zinc in contact form a small short-circuited cell which wastes the zinc away. To prevent this from taking place, a phenomenon termed *local action*, the zinc should be amalgamated by first dipping it in acid and then allowing it to come into contact with mercury, forming a film of mercury over the zinc. The mercury forms an amalgam with the zinc, which floats the lighter impurities such as iron to the surface, separating the iron from the zinc, so that both are not in contact with the acid at the same time. Local action is not alone confined to batteries, but occurs whenever two dissimilar metals in contact are exposed to the elements, such as salt air or salt water. Thus, when in street manholes that contain feeders supported on iron straps fastened to racks, salt water has entered the manholes, the lead armor of the sheathing of the cable has often been found to be eaten away where the cable had come into contact with the supporting iron strips. In aerial transmission lines where aluminium wire is used, it is necessary to fasten the wires together with aluminium connectors, for where the wires are joined together with copper connectors, it has been found that electrolytic action frequently occurs. On the bottom of boats where iron bolts have come into contact with the copper sheathing, electrolytic action has been noticed. It

is always well to remember that two dissimilar metals in contact exposed to an acid or a salt solution constitute a cell, and electrolytic action, sometimes called *galvanic action*, is likely to occur.

**Gravity Cell.** — The gravity cell, Fig. 114, is a special form of Daniell cell used extensively in practice. The copper electrode, Fig. 115, is fan-shaped and is placed in the bottom of the jar submerged in a concentrated solution of copper sulphate. Over the top of the copper electrode is sometimes placed a copper tray containing holes. Over the



FIG. 114. — Gravity Cell (M. E. S. Co.).

tray is placed a layer of copper sulphate crystals. This method places the crystals in such a position that they will not interfere with the contact of the electrolyte against the copper electrode; it also serves with the assistance of gravity to keep the copper sulphate saturated. In filling the cell over the top of the copper sulphate crystals is placed a round thin board which floats on top of the copper sulphate solution. A di-

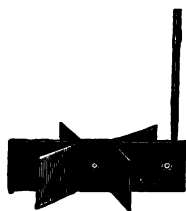

FIG. 115. — Copper Electrode.

lute solution of sulphuric acid is next poured through a funnel so that the stream will strike the center of the float. The float will gradually rise until the vessel is almost full of liquid. The zinc electrode, Fig. 116,



FIG. 116. — Crow-foot Zinc.

is next introduced, completing the cell. Occasionally the zinc electrode has a central support which passes through a porcelain cover, preventing evaporation.



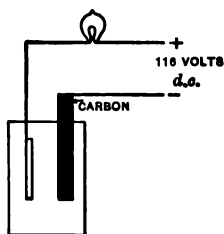

FIG. 117.—Plating of Copper.

**Experiment 46.** Form a circuit of a 16-candle-power lamp, a copper and a carbon electrode immersed in copper sulphate solution, and a 116-volt direct current source of supply, Fig. 117. Be sure that the carbon rod is connected to the negative electrode. Turn on the current and notice that after a time copper is deposited upon the carbon rod. This experiment illustrates the action taking place in a gravity cell, and shows that the copper electrode is positive and that copper is deposited upon it while the cell is in action.

**Bunsen and Grove Cells.**— Both of these cells are of the two-fluid type. The Bunsen cell has a zinc electrode immersed in dilute  $H_2SO$  and the carbon suspended in a porous cup containing nitric acid. The Grove cell is somewhat similar in detail, except that a platinum electrode is substituted for the carbon electrode in the porous cup. These cells give potentials of 1.75 to 1.95 volts and produce constant currents of considerable strength. They are especially adapted for experimental work, the only objection to them being the noxious fumes of the nitric acid. This difficulty, however, can be overcome by using a solution of bichromate of potash.

**Grenet Cell.**— The Grenet cell consists of two carbon plates and a zinc plate immersed in a solution of bichromate of potash. When not in use, the zinc should be raised. This cell gives 2 volts, a very high potential compared with other cells, and is well adapted for experimental work, especially in cases where the building in which the experimenting is done is not wired for electric current. Many of the experiments described in this text can be performed with three of these cells in series, giving 6 volts. The Grenet cell after a time loses its strength, owing to the

depolarizing action of the electrolyte. The liquid loses its deep red color with age.

**Open Circuit Cells.** — Cells which are used infrequently as in the case of bells and annunciators, are termed *open circuit cells*. Such cells as a rule give a high amperage on short circuit. Some forms of dry battery, like the Red Seal Dry Battery, Fig. 121, made by the Manhattan Electrical Supply Co. of New York, will yield 20 amperes on short circuit, having a potential of 1.5 volts. Such a cell has naturally a low internal resistance,  $1.5/20 = .075$  ohms. Cells having high amperages have a slightly decreased life. The above-mentioned cell has a life of one year.

**Leclanché Cell.** — This cell, Fig. 118, contains a carbon electrode surrounded with broken carbon and dioxide of manganese suspended in a porous cup sealed at the top and having a small air vent. The



FIG. 119. — Zinc for Leclanché Cell.

porous cup is placed in a jar containing sal ammoniac solution together with the zinc electrode, Fig. 119. The top of the jar is covered with wax to prevent the sal ammoniac solution from crawling up from capillary attraction and crystallizing on the top of the jar.



FIG. 118. — Leclanché Cell.

The e. m. f. of this cell is about 1.48 volts, and its internal resistance is about 4 ohms. Under normal conditions of external use the depolarizer will take care of the hydrogen liberated, but if an attempt is made to use this cell upon continuous service, the hydrogen gas will be liberated more quickly than it can be absorbed, and the cell will polarize. If the zinc is amalgamated, it will not be consumed except when the battery is in operation.

**Experiment 47.** — A simple way to make a saturated solution of copper sulphate to be used in connection with gravity cells is to fill a dish with water, place a piece of gauze in the top of the dish, and put some copper sulphate crystals in the gauze tray. The copper sulphate will dissolve and fall to the bottom of the dish in hair-like streams. This process will continue until the copper sulphate solution is completely saturated; thereafter no more copper sulphate will dissolve. This experiment may be performed on a horizontal lantern with one of the small tanks shown in Fig. 107. It forms a very attractive experiment.



FIG. 120. — Dry Cell.

**Experiment 48.** — In a gravity cell the two liquids in contact, the copper sulphate solution and the sulphuric acid, remain separate because of their difference in specific gravity. Take a small projecting tank and fill it half full of dilute sulphuric acid. Into the tank place a small thistle tube, allowing it to reach to the bottom. Slowly pour the copper sulphate solution into the tube, and notice the sulphuric acid solution rise in the tank while the copper sulphate solution remains at the bottom.

**Dry Cells.** — In recent years so-called dry cells, Fig. 120, have been placed upon the market, convenient to use because of their absence of liquid. They employ zinc and carbon as electrodes, the active mixture consisting of a combination in dust-like form of zinc oxide 1 part, sal ammoniac 1 part, chloride of zinc 1 part, water 2 parts, and plaster 3 parts. These cells can be purchased in quantities from concerns like the Manhattan Electrical Supply Co. of New York, for about 12½ cents apiece. They may be readily placed in series to obtain potentials of 100 volts or more. They cost slightly



FIG. 121. — Dry Cell.

more than the Leclanché cells to maintain, as their life is somewhat shorter, only about one year; but the difference is so slight, considering the time necessary to recharge the Leclanché cells, that the writer uses them exclusively. Their e. m. f. varies from 1.2 to 1.5 volts, and they may be used in calibrating voltmeters and in many forms of experimental work. In such cases the voltage is so constant that they take the place of storage batteries.

### THE STORAGE BATTERY

**Theory of the Storage Battery.**—The storage battery owes its creation to Gaston Planté, who, in 1860, developed the first storage battery with what is known as formed plates. The electrodes in the Planté cell were first formed by charging a pair of lead plates in one direction and then in the opposite direction. This process of charging and discharging was continued for several minutes, at the end of which time the cathode plate became sponge lead and the anode plate peroxide of lead. In 1881 Émil Faure developed an improved form of battery, using the same elements as Planté—peroxide of lead and sponge lead—except that the plates were what are termed pasted plates, the active material, peroxide of lead, being pasted upon the plates and then charged once instead of being formed electrically, as in the Planté process. Battery manufacturers at the present day tend to employ both processes, using the pasted negative plate almost exclusively, and the pasted positive plate where a light battery is required and the service is gradual. For heavy station work, where the changes in load are sudden and where weight is not so important a factor, the formed Planté plate is preferred. The chemical

action which occurs in a storage battery under conditions of charge and discharge is expressed in the following convenient way by Lamar Lyndon:

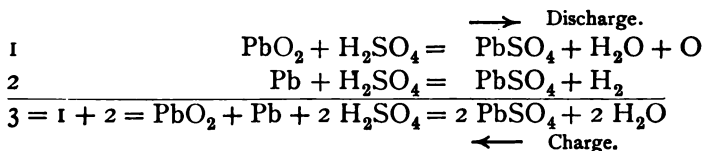

Interpretation, —

$\text{PbO}_2$  = lead peroxide  
 $\text{H}_2\text{SO}_4$  = sulphuric acid  
 $\text{Pb}$  = sponge lead  
 $\text{O}$  = oxygen  
 $\text{H}$  = hydrogen  
 $\text{PbSO}_4$  = lead sulphate.

Both the lead peroxide and the sponge lead are conductors of electricity, whereas the lead sulphate is an insulator. As the battery discharges, this lead sulphate forms on both the positive and negative plates, increasing the internal resistance of the cell and lowering the cell's voltage. As the lead sulphate is formed, it robs the battery solution more and more of its acid radical,  $\text{SO}_4$ , which increases the resistance of the conducting solution. It is interesting to note in this connection that pure water has a very high resistance, as has also concentrated sulphuric acid, but any mixture of the two produces a decreased resistance. This effect is shown in the curve, Fig. 122.

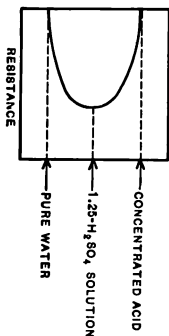

FIG. 122 — Variation of Resistance of  $\text{H}_2\text{SO}_4$ .

**Experiment 49.** Take a dish containing distilled water, arrange in it two platinum electrodes which have been previously washed in distilled water, and place the electrodes in series with a 16-candle-power lamp and the 116-volt Edison direct current service, Fig. 123. Turn on the power, and notice that the lamp will not light. This shows that no current of any appreciable extent passes, owing to the high resistance of the distilled water. Add a few drops of sulphuric acid, and notice that the filament of the lamp becomes a dull red, showing the passage of a current. Add a few more drops of acid and notice that the lamp lights to practically its full intensity.

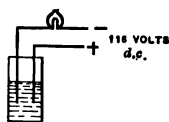

FIG. 123.—High Resistance of Pure Water.

**Experiment 50.** Place some lead peroxide,  $\text{PbO}_2$ , on a metal plate forming the positive terminal of a 116-volt direct current service. Upon the top of the lead peroxide place another metal plate, so that the two plates will be separated by a layer of lead peroxide. Connect the second plate to the other terminal of the direct current service, placing a 16-candle-power lamp in series with it. Turn on the power and notice that the lamp will light, owing to the conductivity of the lead peroxide. Repeat the previous experiment, using some sponge lead in place of the lead peroxide, and notice that the lamp will also light, owing to the conductivity of the sponge lead.



FIG. 124.—Conductivity of  $\text{PbO}_2$  and  $\text{PbSO}_4$  Shown.

**Experiment 51.** Again repeat the experiment, using lead sulphate,  $\text{PbSO}_4$ , in place of the sponge lead, and notice that *the lamp will not light*, owing to high resistance of lead sulphate. (See Fig. 124.)

**Operation of a Storage Battery.**—The potential of a lead storage cell should never be allowed to fall below 1.7 volts, since it will become so badly sulphated that it will be almost impossible to restore the cell to its normal condition. The life of a battery plate under proper care is directly proportional to the number of times it is charged and discharged. Formerly, with large central stations such as are used by the lighting companies, it was customary to charge the cells during light load and to discharge

them during peak load. After a trial of seven years it was found that the plates had become practically useless. At present, the chief function of these batteries is to serve as a factor of *reliability*, floating continuously on the system to carry the load in case the generating apparatus becomes disabled. They also serve to regulate the unbalance on the three-wire system, but this factor is largely taken care of by balances operating in parallel with the cells. For a short interval of time a storage battery can carry very heavy overloads, 200 and 300 % of normal. During a complete shut-down of one of the large generating stations in New York City at one time the batteries carried the entire load for 15 minutes till the generating apparatus could be put back again on the system. One of the large railway companies in New York City has installed a storage battery throughout its electric system of such magnitude that, should the generating apparatus become disabled, the battery will carry the load for 40 minutes, a very valuable feature in rush hours. The factor of reliability or of load continuity has such an important bearing upon the life of the electrical industry that it is the chief asset of the storage battery.

**Rating of Cells.**— A cell is usually rated on the basis of a certain current discharge for a certain number of hours.



FIG. 125.  
Battery  
Pellet.

Thus, a 100-ampere 8-hour cell means a continuous discharge of 100 amperes for 8 hours. If this rate of discharge be increased, the hour rating will decrease. For instance, it would not be possible to maintain double this rate for 4 hours. This is due to the fact that the lead sulphate is formed in a layer on the outside of the pellets of the cell, as in Fig. 125, with a heavy rate of discharge, whereas with a slow rate of discharge the sulphate has time to work its

way through the whole pellet. In the former case the internal resistance of the cell increases rapidly, causing the potential to fall.

**Experiment 52.** Take a cell and discharge it at various rates, charging after each discharge. Maintain the current constant while the discharge is taking place by varying the resistance in series with the cell. Plot the curve, Fig. 126, for different discharges, using ampere rate for each curve, plotting the curves in terms of potential and hours.

**Experiment 53.** Take a storage battery plate, Fig. 127, which has been badly sulphated and connect the grid of the plate through a 16-candle-power lamp to the positive terminal of a 116-volt direct current lighting service.

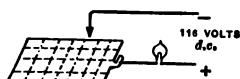

FIG. 127. — Testing Sulphated Plate.

With a test wire connected to the negative terminal touch the plate at various points on the sulphated pellets, and notice that the lamp will not light. Touch the lead grid, and notice that the lamp will light.

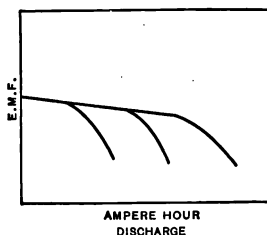

FIG. 126. — Battery Discharge Curve.

**How to charge a Storage Battery.** — A number of storage cells or pairs of plates connected in series constitute a storage battery. For each cell a potential of about 2 volts is obtained. For a three-wire 120–240-volt circuit it requires 60 cells on each side of the system. In order to distribute 120 volts it is necessary to have a greater number of cells than 60 on each side of the system to allow for drop in voltage due to resistance of distributing mains.

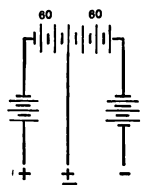

FIG. 128. — End Cells.

A number of extra cells are therefore added to allow for this loss in potential, these cells being termed *end cells*, Fig. 128. An adjustable contact, motor-operated, serves to



cut in the number of cells required. To charge a battery the current should be sent into the battery in the same direction in which it comes out. The positive terminal of the battery should, in other

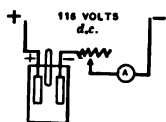

FIG. 129.— Battery charging service, Figs. 129, 131, 132.

Care should be taken to see that this connection is properly made, or the battery will be likely to be ruined beyond repair. There is no known satisfactory method of restoring a storage battery plate which has been badly sulphated. From a source of direct potential an ammeter should be placed in series with an adjustable resistance and the negative plate of the battery, Fig. 129. A voltmeter should be connected across the terminals of the battery, and a hydrometer should be placed in the liquid



FIG. 130.— Test Hydrometer (E. S. B. Co.).

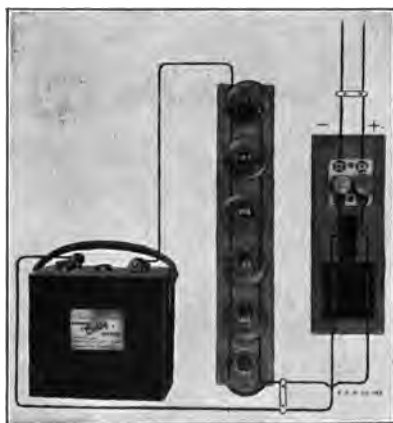

FIG. 131.— Charging Circuit.

of the cell to note when the specific gravity of the cell is normal. A test hydrometer similar to that developed by the Electric Storage Battery Co., Fig. 130, may be used. The voltage of the cell when charged should be slightly above normal, and the specific gravity of the cell should be 1.23 Baumé. When a battery is completely

charged, it gases badly. Battery charging circuits employing lamps and adjustable resistances are shown in Figs. 131, 132.

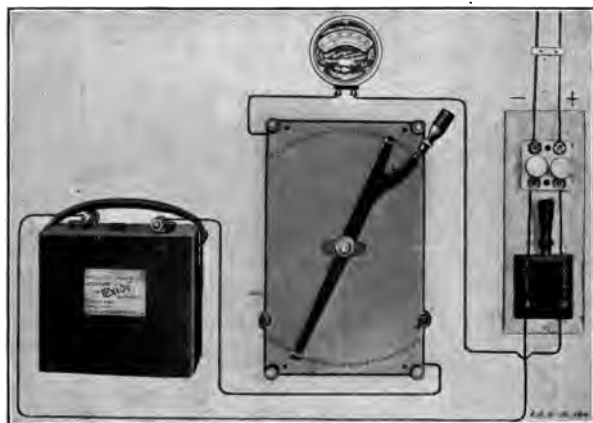

FIG. 132. — Charging Circuit.

**Edison Cell.** — With all forms of lead storage cells there are certain objectionable features, such as acid fumes, the deterioration of the plates, the necessity for proper ventilation, and the need of a fume proof room to inclose the battery. When storage batteries are used in automobiles, it is found that in time the acid fumes eat the body from out of the carriage. A greater objection still for automobile use is the excessive weight of the lead cells, the weight per pound of battery per watt hour of cell being high. Mr. Thomas A. Edison in his new form of cell has endeavored to overcome these difficulties. His cell consists of electrodes of iron and nickel made up in the form of pellets inclosed in supporting rectangular baskets of steel netting. These baskets are fastened into a steel grid, in which are rectangular openings. For an electrolyte caustic potash is used. The

result is a cell which is light and mechanically strong, with an electrolyte in which you could put your hands without injury, and yielding a large wattage per pound of cell. The potential of the cell is about one half that of the lead cell. In the early development of the cell the active material did not make proper contact in its inclosing baskets, an insufficient surface of active material was exposed, and gas formed between the baskets and the active material. It is now claimed by the manufacturers of this cell that practically all of these difficulties have been obviated.

**Types of Commercial Cells.** — At the time that Emil Faure was developing the pasted type of storage battery plate, Mr. Charles F. Brush in America discovered the same principle, and consequently the Brush patents have ever since controlled the pasted type of plate in this country. The original pasted plate, as developed by Faure, consisted



FIG. 133 — Tudor Plates  
(E. S. B. Co.).

of sheets of thin lead roughened upon their surface. Over this surface was spread the lead oxide. This method, however, did not prove commercially successful, as the active material, or lead peroxide, on the positive plate, seemed to lose its grip upon the supporting grid and fall away. Many forms of grid for locking the material in were developed, among the first inventions being those of Swan in England and Brush in America. Nearly all of these types of grid



FIG. 134. — Laboratory Chloride Cell.

proved inadequate. Some types, however, survived, among which may be mentioned the Tudor plate, Fig. 133, and the chloride plate, Figs. 134, 135. With the Tudor plate the grid, after being cast, was passed through rolls which turned over part of each fin, giving a grip on the material. With the chloride plate the active material is made into small blocks placed in a mold, and the lead grid is cast around it. Among the latest developments as used by the Electric Storage Battery Company may be mentioned the box plate, Fig. 136, consisting of two grids, each having a perforated sheet of lead cast upon one side riveted together with the sheet on the other side.



FIG. 135. — Telephone Chloride Cell.



FIG. 136. — Box Negative  
(E. S. B. Co.).

This forms a number of inclosed pockets which hold the active material. With the continued use of the peroxide pasted plate it was found that the active material would wash off. This led to the use of the combination Faure negative plate and the Planté positive plate for heavy duty, and where the service was light, as for automobiles, the pasted plate, Exide, Fig. 137, was used. With the Planté type of positive, the peroxide is a



thin layer, very closely grained, well protected in the interstices of the plate so that it may not be readily washed away. As the peroxide gradually disintegrates,

new peroxide is gradually formed by the working of the cell upon the grid. In America the Manchester type of plate is manufactured by the Electric Storage Battery Company. This plate, Fig. 138, consists of a grid made of a casting of lead antimony that forms an alloy more rigid than the pure lead and prevents buckling. The circular holes,  $\frac{3}{4}$  inch in diameter, in this grid are filled with spiral buttons



FIG. 137. — Exide Battery.

made of corrugated pure lead ribbon. The buttons are forced into the openings of the grid by hydraulic pressure, which securely locks them in position. During the forming process of the Planté plate, the buttons expand, resulting in excellent electrical contact.

The box negative plates, Fig. 136, of the Electric Storage Battery Company consist of an alloy grid made with a number of small pockets which are filled with finely divided porous lead sponge.



FIG. 138. — Manchester Positive (E. S. B. Co.).

This lead is not adapted to be mechanically self-supporting, hence it is placed in the pockets of the grid, incased in a thin sheet of perforated lead which keeps it in position. The box negative plate is used with either the Manchester plate or the Tudor positive plate, Figs. 136, 138. Tudor positive plates are made by the Electric Storage Battery Company. They are of the Planté type, Fig. 133, and consist of a single piece of lead with a number of vertical ribs extending from face to face, allowing thorough circulation of the electrolyte between the narrow spaces. At proper intervals the ribs are supported by horizontal ribs to insure proper rigidity.

Rolled negative plates, Fig. 139, consist of rolled lead having vertical ribs on both sides of a center web. The ribs are separated by spaces, which in the formation are filled with active material integral with the body of the plate, no material being artificially applied. This negative plate is used only with the Tudor positive plate. The chloride accumulators, Figs. 134, 135, use a Manchester positive plate and a box negative, the Tudor accumulator, Fig. 133, contains a Tudor positive plate and a rolled negative plate. Another compact form of plate, the shelf negative, also made by the Electric Storage Battery Company, is shown in Fig. 140.



FIG. 139. — Rolled Negative.



FIG. 140. — Shelf Negative.

## QUESTIONS

1. What is a primary battery and how is its potential affected by kind of electrodes and electrolyte?
2. How is the internal resistance of a cell affected by the size of the electrodes, and how would you measure this resistance with an ammeter and voltmeter?
3. What does the term *polarization* mean and how is polarization minimized in a single fluid cell and eliminated in a two-fluid cell?
4. Draw diagram of cell containing zinc and copper electrodes, show positive and negative terminals, direction of current inside of cell and in external circuit assuming that current passes from + to -.
5. How does a storage battery differ from a primary battery?
6. Explain how lead sulphate enters into the operation of a storage cell.
7. Why cannot the same watt hour output be obtained from a cell irrespective of the rate of discharge?
8. Draw diagram showing how storage cell is set up to be charged. What precautions should be taken?
9. Give three indications that a battery is charged, all of which should be used.
10. Is the internal resistance of a storage cell high or low? Would the current on short circuit be large or small?
11. Why in the operation of a large battery is it desirable to consider it in an operating way the same as a generator regarding loads, short circuits, etc.?

## CHAPTER VI

### ELECTROLYSIS

**Electrolytic Corrosion.**—Too frequently the term *electrolysis* is confused with the term *electrolytic corrosion*. While the electrolytic corrosion of water pipes is due to electrolysis, caused by stray currents of electricity, the term *electrolysis* refers to any of the processes of dissociation, such as electric plating, the manufacture of electrolytic compounds like aluminium, and the electrolytic recovery of ores.

**Definition of an Electrolyte.**—While an electrolyte, though a liquid, is a conductor of electricity, *conductors* are usually solid, have with a few exceptions, such as carbon, positive temperature coefficients, and are not split up into component parts during the passage of an electric current. Pure copper would be a conductor, whereas copper sulphate would be an *electrolyte*. Some comparatively good insulators when cold become electrolytic conductors when heated. Various forms of glass containing metallic oxides are good insulators when cold, but become electrolytic conductors when molten.

**Experiment 54.**—Take a small test tube about  $\frac{3}{4}$  inch in diameter and fill to a depth of  $\frac{1}{2}$  inch with sodium acetate, powdered, Fig. 141. Pass two steel needles through a stopper in the top of the tube, extending down to almost the bottom of the tube, so that when the powder melts they will make contact, taking care that the needles are not in contact. Connect the two steel electrodes to a 116-volt direct current



service through a 16-candle-power lamp in series with it. Shunt with

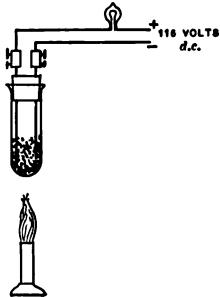

FIG. 141. — Conductivity of Sodium Acetate changed with Heat.

a piece of wire the two steel needles for an instant with power on, noting that the lamp lights and that when the shunt is removed the lamp will not light. Heat the tube gently with a bunsen burner with the current on the circuit. At first the lamp will not light, then it will become a dull red, and then it will finally light to full intensity. If it is desired to repeat the experiment, wash the tube and remove the electrolytic deposit from the ends of the needles, and be sure that there is no moisture in the tube when the sodium acetate is added.

**Experiment 55.**— Take a fine iron wire, about a No. 30, and coil it up in the form of a helix, mounting it to two supports passed through a cork, Fig. 142. Support the cork in a clip stand and be sure that none of the spirals of the wire touch one another. Connect the terminals of the helix in series with a galvanometer, shunted, a dry battery, and sufficient external resistance so that a full scale deflection of galvanometer is obtained. Heat the iron wire slowly, taking care not to raise it to too high an incandescence lest it burn, and note the decreased

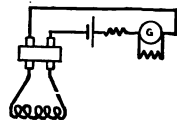

FIG. 142. — Positive Temperature Coefficient.

reading of the galvanometer due to the *positive temperature coefficient* of the wire (lantern experiment).

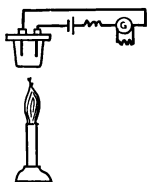

FIG. 143. — Negative Temperature Coefficient.

**Experiment 56.**— Repeat the previous experiment, substituting for the iron wire helix two electrodes of copper immersed in a solution of copper sulphate, Fig. 143. Readjust the resistance in series so that now only a small deflection of the galvanometer takes place. Heat the glass containing copper sulphate slowly, and note that the deflection of the galvanometer increases, due to the *negative temperature coefficient* of the copper sulphate (lantern experiment).

**Decomposition of Acid Solutions.**— Electrolysis is the process of separating a compound electrolytically into its

constituents. Some liquids, notably mercury, will conduct electricity without suffering disintegration. When an electric current is passed through water slightly acid, the water is split up into its two constituent gases — hydrogen two parts and oxygen one part, the gases being evolved at the electrodes. If these two gases be mixed in the same proportion and ignited, an explosion will occur and water will result. Naturally, the water formed will not occupy the same volume as its component gases, but will deposit itself in small drops over the surface of the inclosing tube. The first evidence of electrolysis was detected in 1800, when Nicholson and Carlisle discovered the electrolysis of water. Sir Humphry Davy carried on a series of exhaustive experiments on alkaline earths, and the caustic alkalis a little later, in 1807, producing among other things by electrolysis sodium and potassium. Faraday, however, was the one who first formulated the fundamental law of electrolysis,

$$M = Izt,$$

or that the weight of metal deposited in grams  $M$  varies as the current  $I$ , the time  $t$  the current is passing, and as the electro-chemical equivalent of the substance  $z$ . Each ampere second, or coulomb, throws out of solution a weight of metal equal to its electro-chemical equivalent. Dr. Sylvanus Thomson gives the following values of electro-chemical equivalents for some of the principal elements :

Hydrogen . . . . .	.000010384
Gold . . . . .	.0006791
Silver . . . . .	.0011181
Copper (cuprous) . . . . .	.0006562
Tin (stannous) . . . . .	.0006116
Iron (ferrous) . . . . .	.0002902

Nickel	.	.	.	.	.	.	.0003043
Zinc	.	.	.	.	.	.	.00033698
Lead	.	.	.	.	.	.	.0010716
Oxygen	.	.	.	.	.	.	.00008286

There are two steps which occur in an electrolytic process, the general splitting up of the molecule into its constituents or *ions*, and the effect which these ions are likely to have upon the electrodes. The first of these steps is illustrated in the electrolysis of water, where platinum electrodes are used, the *nascent* gas not attacking the electrodes. In the following experiment, where copper electrodes are used, the electrodes are attacked, showing the second step in the process.

**Experiment 57.** Place two copper electrodes in a projecting tank containing a solution of sodium acetate, Fig. 144. The writer prefers

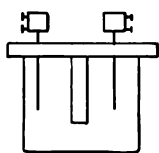

FIG. 144. — Electrolysis Projecting Tank.

this to hydrochloric acid, as the acid attacks the sides of the tank if they happen to be of metal. Insert a reversing switch in series with a 16-candle-power lamp and a 116-volt direct current service, Fig. 145. When the current is on, notice that gas only rises — oxygen — from the positive electrode, the hydrogen evolved at the negative electrode attacking the copper electrode. Throw the reversing switch, changing the direction of the current through the cell, and notice a black deposit rise from the former negative electrode. This is some form of hydride of copper which is being carried up by the oxygen gas. This experiment proves the second step in the electrolytic process, namely, that the *anions* are going to the anode, or positive electrode, and that the *kations* as electro-positive are being attracted to the kathode or negative electrode.

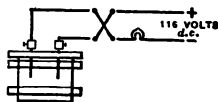

FIG. 145. — Decomposition of Acid Solutions.

*The metals and hydrogen are kations and always travel to the negative electrode or with the current, while oxygen and the chlorides are anions and travel to the positive elec-*

*trode*. The terms *anions* and *kathions* were suggested by Faraday.

**Experiment 58.** Repeat the previous experiment, using a tank with a partial partition, Fig. 144, platinum electrodes, the reversing switch, a 16-candle-power lamp, and a few drops of phenol-phthalein, dissolved in alcohol, to the solution. Do not add too much phenol-phthalein, or the liquid will be too cloudy to appear well on the screen. Turn on the current and notice that after a time bubbles of gas will arise from one electrode, the sodium acetate solution at the other electrode becoming a deep crimson. Throw the reversing switch, shake the tank slightly, and notice that the crimson liquid clears up on one side, and that now the liquid on the other side of the tank becomes crimson.

**Experiment 59.** To show that oxygen and hydrogen are liberated when a dilute solution of sulphuric acid and water is electrolyzed and that they are liberated in the proportion of two parts of hydrogen and one of oxygen, recourse may be made to the Hoffman voltameter, Figs. 146, 147, consisting of two tubes connected through a U to another tube containing a reservoir at the top. The two main tubes *A*, *D*, Fig. 146, 147, are graduated similar to a burette and have pet cocks at their tops to emit the gases when desired. At the bottom of the U another pet cock is inserted so that the liquid may be drained from the tube. Fill the Hoffman apparatus with water slightly acid by pouring the solution in the reservoir *B*, turning off the pet

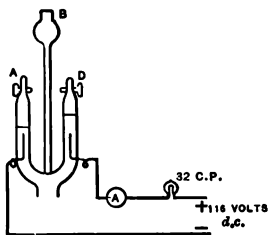

FIG. 146. — Hoffman Voltmeter.

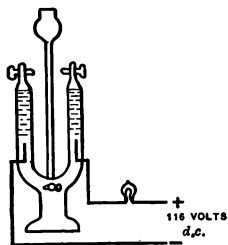

FIG. 147. — Electro-chemical Equivalent of Hydrogen.

cock at the bottom of the U and at the top of the tubes. Turn on separately and slowly the pet cocks at the top of each tube, allowing the acid solution to rise until it fills the tubes, and then turn off the pet cocks. Do not have too much extra liquid in the reservoir when the main tubes are filled with liquid, or, when gas is developed, there will be no room for the liquid driven out of the tubes, and it will rise over the top of the reservoir. In the bottom of each of the main tubes is a platinum elec-

trode extending through the glass to terminals. These terminals should be fastened to binding posts mounted on the base of the apparatus, so that connections cannot be made on the fragile inlet wires, but must be made at the binding posts. Connect the binding posts of the voltameter in series with a 16-candle-power lamp and a 116-volt direct current source of potential. Gases will be developed, hydrogen rising at the negative electrode and oxygen at the positive electrode. When sufficient gas has collected, read graduations on the tubes, and notice that the volume of hydrogen is twice the volume of oxygen.

**Experiment 60.** Test the oxygen by holding over the tube a small splinter of wood which has been previously lighted but which has had the blaze blown out, leaving only a few sparks remaining. Be sure that no liquid, not even a small drop, is left in the top of the test tube, or, when the pet cock is turned on, the drop of liquid will be forced by the escaping gas against the spark on the splinter of wood, extinguishing it. When all these precautions have been taken, turn on the pet cock, holding the piece of wood containing the sparks in close proximity to the outlet; the splinter will immediately burst into flame.

**Experiment 61.** Test for hydrogen by holding a small test tube one half an inch in diameter and three inches long over the opening of the hydrogen tube so that the gas will enter near the middle of the tube. When the gas has been passing into the tube for a brief time, place the thumb quickly over the mouth of the tube, and then bring the mouth of the tube near a bunsen flame, at the same time quickly removing the finger. A small explosion will result, owing to the mixture of the hydrogen gas with the air.

**Experiment 62.** Repeat the experiment of developing the gases with an ammeter in the circuit, noting the volume of gas developed in a given time and the current consumed. Calculate the ampere seconds, or coulombs, and read the volume of gas. When reading the true volume of the gas, turn on the pet cock at the bottom of the U-tube and the pet cock on the tube containing gas which is not being tested, and allow the liquids in the reservoir tube and the untested tube to fall until the liquid in the three tubes is on the same level. Read the temperature of the gas tested by suspending a thermometer alongside of the tube being tested, and read the barometer. Reduce the temperature to zero and the barometer reading to 30 inches, calculating the true volume at this temperature. Divide the volume of the gas, corrected, into the coulombs used, and determine the *electro-chemical equivalent of hydrogen*.

Small polarity indicators, Figs. 148, 149, depend for their operation upon the principle of electrolysis, the liquid in the indicator turning red at the positive electrode when the indicator is placed across a 116-volt direct current circuit.



FIG. 148.—Polarity Indicator (M. E. S. Co.).

**Metallic Salt Solution.** — With a metallic salt solution the process of electrolysis may be termed complete, as the concentration of the solution remains the same at all times, owing to the fact that

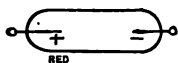
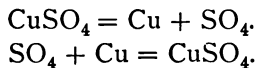

FIG. 149.—Polarity Indicator.

the positive electrode is dissolved into solution in the electrolyte at the same rate that metal is deposited upon the negative electrode from the solution. With copper sulphate, for instance, employing copper electrodes, metallic copper is deposited upon the negative electrode as metallic copper is dissolved from the positive electrode. When the molecule of copper sulphate,  $\text{CuSO}_4$ , is split up by electrolysis into metallic copper,  $\text{Cu}$ , and sulphion,  $\text{SO}_4$ , the metallic copper is attracted to the negative electrode, where it is deposited upon the electrode; the sulphion is attracted to the positive electrode, where the sulphion, having a strong affinity for the copper positive electrode, dissolves it into solution. The reaction may be written as follows:



The electrolytic refining of copper is carried on extensively by this method. In such refining are required a large number of tanks containing  $\text{CuSO}_4$ , together with the electrodes of copper, one of which is very thin and of pure

copper, the other very thick and of cast copper ingots. From the residue of the positive copper ingots it is possible to separate enough gold and silver to cover the entire cost of the refining, and the copper obtained is purer than the Matthiesen standard.

**Electroplating.** — A large industry has arisen during the past ten years, depending for its activity upon the electro-deposition of metals. Copper, gold, silver, nickel, and brass are some of the metals which may be plated by electrolytic processes.

**Copper Plating.** — Copper plating is used extensively in the manufacture of electrotypes for printing. A wax impression is made from the type when set up, this impression being coated with a conducting film of copper. This film is obtained by washing the impression with a mixture of iron filings and  $\text{CuSO}_4$ . The impression is then placed in an electrolytic  $\text{CuSO}_4$  bath and metallic copper deposited. When a sufficient thickness has accumulated hot water is passed over the thin deposit and it is then easily separated from the wax. It is then backed up with metal to give rigidity. Articles which are to be copper plated, if non-conducting, are treated in a somewhat similar manner, namely dusted with a layer of conducting black lead. A good copper-plating bath can be made up as follows: for each gallon of water 2 ounces of potassium carbonate, 5 ounces of copper carbonate, and 10 ounces of cyanide of potassium. About  $\frac{9}{10}$  of the potassium cyanide should first be dissolved in a portion of the water, and then nearly all of the copper carbonate, which has also been dissolved, should be added. The potash should next be dissolved and added to the mixture. Copper or cyanide should be added to the solution after testing it, until the deposit is satisfactory. Where copper is

deposited upon a non-conductor, it is coated with black lead.

**Experiment 63.** Prepare a standard copper plating solution; plate an electrode, weigh both electrodes before and after, and prove Faraday's law.

**Gold Plating.** — Three solutions are in use in gold plating to give the different coloring effects known as California gold, green gold, and red gold. In making the solutions the following salts are dissolved in nitro-hydrochloric acid: an alloy of 22 parts gold and 2 parts silver is used for California gold; an alloy of 16 parts gold and 8 parts silver is used for green gold; and an alloy of 16 parts gold and 8 parts of copper for red gold. The chlorides of these metals remain upon evaporation, and are dissolved in a solution of cyanide of potassium. The anodes must be of pure gold. A difference of potential of 5 volts is used in the bath. As the rate of solution of the anode is not the same as the rate of deposit of the kathode, the solution must be occasionally replenished. The electrolyte is not circulated as in the case of copper sulphate.

**Silver Plating.** — The standard silver-plating solution consists of silver chloride with 9 to 12 ounces of a 98% solution of potassium cyanide per gallon of water. Owing to a tendency of the silver to deposit in arborescent crystals, the articles to be plated have to be kept in motion in a plane parallel to the anode surface. The most suitable current density for silver plating is 1 ampere for 60 square inches of coated surface. If the solution becomes impoverished or weak, it is necessary to add more cyanide. A weak solution is indicated by a violet tinge in the deposit. Too much cyanide produces a yellowish or brownish color.



**Nickel Plating.** — Nickel ammonium sulphate seems to be about the best substance to use for nickel plating. Dissolve about 13 oz. of this salt in a gallon of water, and neutralize the solution by the addition of ammonia or sulphuric acid. A current density of .4 to .8 amperes for 15 square inches of surface and a voltage of 3.5 to 6 volts is a satisfactory working formula to use. A good color is given to the deposit if the solution is just slightly acid. If it is too acid, the deposit will peel; whereas, if the solution is too alkaline, the deposit will be dark.

**Brass-plating Solution.** — The best brass-plating solution contains equal parts of zinc and copper cyanide or carbonate dissolved in ammonium carbonate. A variation of these equal quantities will change the color of the deposit.

**Plating E. M. F.'s.** — The following voltages have been given as most suitable for bath potentials for plating :

Copper in sulphate . . . .	1.5-2.5 volts
Copper in cyanide . . . .	4.-6.0 volts
Silver in cyanide . . . .	1.-2.0 volts
Gold in cyanide . . . .	0.5-3.0 volts
Nickel in sulphate . . . .	2.5-5.5 volts

Given a solution containing a mixture of metals, it is possible by using different potentials to separate out each by electrolysis.

**Critical Current Density.** — The maximum rate at which a metal may be taken from a solution and deposited, the deposit being of a reguline character, is termed the *critical current density* of that solution. A current value greater than the critical value results in depositing the hydrogen in conjunction with the metal, forming what might be termed a hydride deposit. This deposit is pulverulent and will not adhere. The critical current density of a solution

may be readily determined by means of the simple apparatus described in the following experiment. The critical current density may be increased by circulating the electrolyte and by raising the temperature or increasing the concentration.

**Experiment 64.** To determine the critical current density of a solution an apparatus similar to Fig. 150 may be used. It consists of a burette  $2\frac{1}{2}$  inches in diameter at the top, with a pet cock at the bottom which will allow the liquid to run out slowly in about 6 minutes. The depth of the burette is about 5 inches. For copper solutions the central negative electrode consists of a rod of copper  $\frac{1}{4}$  of an inch in diameter, extending down through a stopper into the tube. A strip of copper surrounds the rod, thus forming the positive electrode. An ammeter and a 32-candle-power lamp are connected in series with the two electrodes and a 116-volt direct current source of potential. The glass is filled with copper sulphate solution, and the current is turned on, the liquid being allowed to run out into the glass.

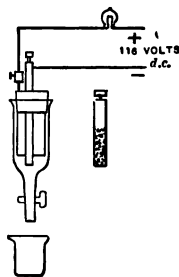

FIG. 150. — Critical Current Density Apparatus.

The current in amperes is noted when it starts to fall rapidly; this occurs when the liquid is almost out of the tube. Determine the area of the dark deposit, not forgetting to include the bottom of the rod, and calculate the critical current density in terms of the amperes per square inch of surface deposited. Before beginning the deposit be sure that negative electrode is clean, and brightly polished. The final deposit should be dark at the bottom with a gradual shading up to the reguline deposit. If this does not occur, leave the tube full of liquid for a time and see with the current on whether a smooth plating of copper over the whole rod occurs. If it does not, and the solution is new, see if the rod has not been made the positive electrode instead of the negative electrode.

### ELECTROLYTIC PRODUCTS

**Alkalies and Bleach.** — Caustic soda or sodium hydrate is made by the electrolysis of common salt solution. Salt, when electrolyzed in the presence of water, forms caustic

soda, but during this reaction other compounds in the form of a mixture of salt, caustic, and hypochlorate of soda are found. In practice the combination is avoided by the use of a porous diaphragm, or by drawing off the caustic soda solution as soon as formed, or by absorbing the metallic sodium by mercury, as in the Casner process using molten lead. Upon the passage of a current using a carbon positive electrode, chlorine is developed; this is conducted off in gaseous form to chambers containing lime, forming bleaching powder. When the mercury combines with the metallic sodium as in the Casner process, it may be separated from the mercury by washing. By using an iron electrode in a solution of water, caustic soda is developed by the secondary reaction. The Casner process is employed in this country at Niagara Falls. A voltage of 4.3 volts is used at the terminals of the cell. A complete description of this process may be found in Foster's Handbook, page 1240, as described by Professor F. B. Crocker.

**Sodium.**—This is manufactured by the electrolysis of caustic soda. At Niagara Falls an iron electrode or vessel, constituting the kathode, is employed. This vessel contains the electrolyte in a fused condition in which dip the anodes in the form of rods. The sodium after being deposited rises to the surface of the liquid, where it is skimmed off. After deposition the sodium is reduced to sodium dioxide by spreading in trays, which are placed in a tube supplied with air and dried over calcium chloride. The sodium peroxide is then used in producing peroxide of hydrogen by mixing it with sulphuric acid at zero temperature, owing to the unstable character of the hydrogen. The process for the electrolysis of metallic sodium is known as the Casner process and requires 4.4 volts.

**Aluminium.** — The Pittsburg Reduction Company at Niagara Falls manufactures this substance in large quantities by the electrolytic reduction of alumina. The double fluoride of aluminium and sodium, in a fused state, is used as a dissociant. The tanks consist of carbon slabs containing the electrolyte, which is maintained in a fused state by the passage of an electric current. The carbon constitutes the kathode, and carbon rods also constitute the anode, dipping in the electrolyte. The metal is drawn off daily from taps leading to the bottom of the cavities in the tank.

**Potassium Chlorate.** — The National Electrolytic Company of Niagara Falls manufactures this substance by the electrolysis of a solution of potassium chloride. The kathode consists of wire gauze covered with cuprous, or copper oxide, and the anode is of platinum. The cells are made of wood covered with lead. The potassium chloride is supplied continuously by a pipe leading to the bottom of the cell. A pipe leading from the top of the cell carries off a mixture of solutions of chloride, chlorate, and hydrogen gas. This solution is led to a refrigerating tank where the temperature is lowered, the chlorate crystallizing out. During electrolysis the temperature of the electrolyte is maintained at about 50° C. by the reduction of the oxides by the liberated hydrogen. About 4 volts is used to electrolyze, of which 1.4 volts is required to convert the chloride into chlorate, and the remainder to develop heat. About 500 amperes per square foot of anode is used for the current density.

**Sponge Lead.** — The process of making sponge lead is employed by the National Battery Company at Buffalo for use in storage batteries. Litharge is placed in contact with a sheet-lead cathode and electrolyzed in a solution of

dilute sulphuric acid in which is suspended the lead anode. Another method of producing sponge lead consists in the electrolytic reduction of galena.

#### THE ELECTRIC FURNACE AND ITS PRODUCTS

While the treatment of the electric furnace belongs under the head of electrolysis, the phenomena which occur in the furnace are due solely to temperature effects and not to electro-chemical action; they may therefore be properly termed electro-thermal actions. The phenomenon likely to occur in the furnace will be one of the following: heating without fusing, as in the manufacture of graphite; heating and chemical change without fusion, as in the manufacture of carborundum; and heating and chemical change, as in the manufacture of calcium carbide. As no electrolytic action occurs in any of these transformations, an alternating as well as a direct current may be used.

**Graphite.** — It was discovered by Acheson in the manufacture of carborundum that when the temperature was carried beyond  $250^{\circ}\text{C}$ . a large amount of graphite was formed around the conducting core. It is a well-known fact that electric light carbons used in street lamps often have a deposit or coating of graphite over the tips after burning for a time. Upon investigation it was found that graphite was formed by simply heating pure carbon to a high temperature, and that a carbide is first formed which is afterwards decomposed by the high temperature. In practice a metallic salt is mixed with the carbon before heating. Three parts of iron oxide is mixed with 97 parts of finely divided carbon, which is molded in various shapes before being graphitized.

With the Acheson Company the articles to be graphitized are placed in a furnace between the electrodes, forming a pile two feet wide by about 35 feet long, the spaces between being filled in with a ground mixture of carbon and carbonates. Through the electrodes are sent 3000 amperes at 200 volts at starting. As the graphitizing proceeds, the resistance decreases, carbon having a negative temperature coefficient, the voltage falling to 80 volts, and the current rising to 9000 amperes.

**Calcium Carbide.** — Calcium carbide, while classed as an explosive, yields when mixed with water a gas which is highly luminous. One pound of carbon when mixed with water produces about 5 cubic feet of acetylene gas whose illuminating power would be equal to about 70 feet of ordinary gas. It gives, however, a sooty flame, although one of high intrinsic brightness. Calcium carbide is made by treating in an electric furnace a mixture of 1 ton of burnt lime and  $\frac{3}{4}$  ton of ground coke, which produces 1 ton of carbide. The reaction is  $\text{CaO} + 3\text{C} = \text{CaC}_2 + \text{CO}$ . The process was developed by Wilkson in 1891. At Niagara Falls, C. S. Bradley has in use a special form of rotary electrode furnace using 3500 amperes at 110 volts, producing one ton of carbide in 12 hours.

**Carborundum.** — This substance, carbide of silicon,  $\text{CSi}$ , is much harder than emery and is used extensively as an abrasive. A mixture of 6 tons of pure sand and  $3\frac{1}{2}$  tons of ground coke, mixed with a small amount of salt and sawdust,  $1\frac{1}{2}$  tons, to make the mixture porous, is heated to a very high temperature, forming beautiful crystals of the carbide to the extent of about 4 tons. At Niagara Falls the furnace consists of a fire brick hearth, 16 feet long, 5 feet wide, set loosely together, and solid brick walls 8 feet high at each end. The current is led into the furnace through

iron frames in the middle to carbon electrodes forming the core.

**Barium Hydrate.** — Barium hydrate is made from crude barytes, one part of barytes being mixed with three parts of barium sulphate, and then heated in an electric furnace. Vapor in the form of  $\text{SO}_2$  is driven off, leaving barium oxide. The oxide on being placed in water becomes hydrated and is then allowed to crystallize. It is used quite extensively in the recovery of sugar from beets and also in the manufacture of pigments.

**Miscellaneous Substances.** — Barium cyanide is made from barium carbonate mixed with coke, producer gas being passed through it while it is heated electrically. Phosphorus is made from pulverized calcium phosphate mixed with coke and placed in an electric furnace. The phosphorus is vaporized and collected under water. Corundum is made by the Norton Emery Company. It is simply purified emery, and is made by heating bauxite in an electric furnace. Iron and steel are made abroad in small quantities by electrolytic processes.

**The Electrolytic Rectifier.** — This device consists of a cell containing an electrolyte of potassium phosphate slightly acid. One electrode is of lead, the other of aluminium which has been macerated in a solution of caustic soda. When this cell is in operation, provided the voltage be below 200 volts and the temperature be below  $40^\circ$ , it will allow current to pass in only one direction from the lead to the aluminium. It is claimed that this action is due to the formation of an insulating skin of aluminium hydrate which skims over the surface of the aluminium anode. An alternating current may be rectified to pulsating direct current, one half of the alternating current lobe being extinguished. The life of the cell is about 500

hours, after which the insulating skin of aluminium hydrate breaks down.

**Electrolytic Interrupter.** — There are two types of electrolytic interrupter, both simple to build and both operating on the same principle. The Wehnelt interrupter, Fig. 151, consists of two electrodes, a lead sheet as kathode and a platinum wire, adjustable, as anode. These electrodes are suspended in a dilute solution of sulphuric acid. During action the electrolyzed gases form on the platinum point, insulating the circuit for the instant. The high temperature of the electrode quickly liberates the gas, making the circuit again conducting. This process of interruption is very rapid, several hundred times a second, and makes an interrupter advantageous for work with induction coils. The Cauldwell interrupter is quite similar, except that for the platinum point is substituted a test tube containing an electrode of lead, a small opening existing in the bottom of the tube over which forms the insulating gas.

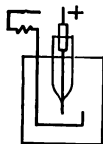

FIG. 151.—  
Wehnelt  
Interrupter.

**The Pail Forge.** — A pail forge consists of a cell containing two electrodes, one of which is thoroughly immersed in a highly conducting liquid, the other electrode just having its extremity projecting below the surface of the liquid. The latter electrode is manipulated by hand when the potential of 220 volts direct current is upon the circuit. The concentration of energy which occurs under these conditions is very great, raising the iron electrode manipulated by hand to the melting point.

**Experiment 65.** Fill the bottom of a glass jar with a layer of sand to prevent the molten particles of iron from falling and breaking the vessel. Place a lead electrode in the bottom of the vessel, connecting it to one terminal, the negative of a 220-volt direct current source.



Fill the vessel with a salt solution and, with the current on, project an iron rod connected to the positive terminal of the service into the top of the liquid. At first, the liquid will begin to sputter, throwing out particles of water. As the temperature of liquid rises, it becomes more conducting, and the iron rod will gradually become red-hot, molten particles of iron dropping from it. Remove the rod when in this condition and shake it; a shower of sparks of molten iron will follow. Care must be taken not to bring the electrodes into contact by mistake, or a short circuit will follow.

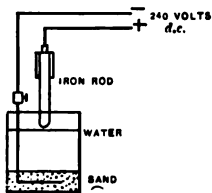

FIG. 152. — Pail Forge.

### QUESTIONS

1. What effect takes place when an electric current is sent through water by means of two electrodes?
2. Why is it that gas only comes from one electrode during electrolysis when copper electrodes are used in a solution of sodium acetate.
3. Explain the principle of electrolysis which prevents polarization in a two-fluid cell.
4. Explain the electrolytic corrosion of water pipes.
5. Differentiate between the various thermal and electrolytic actions which occur in the manufacture of electric furnace products.
6. What will happen if too high a current density is used in the plating of copper?
7. What is the modern theory of electrolysis.

## CHAPTER VII

### THE THREE-WIRE SYSTEM

WHEN Edison first attempted to solve the problem of underground distribution by using the two-wire system,

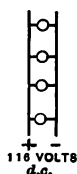

FIG. 153.—  
Two-wire  
System.

Fig. 153, he soon realized that it was limited in its application, owing to the excessive amount of copper required to prevent the voltage from falling too much in the distribution of power. He therefore introduced what is known as the Edison Three-wire System, Fig.

154, which has resulted in saving about 62.5 % of the copper required by the old two-wire system. This value assumes a neutral feeder half as large as the positive and negative feeders. It also

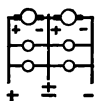

FIG. 155.—Three-  
wire System  
(Generator).

saves a large amount of energy which was formerly wasted in overcoming the resistance

of the wires of the two-wire system. The two-wire system, Fig. 153, consists of two mains supplied by a potential of 116 volts,

requiring but two wires. The three-wire system consists of three wires having a potential difference of about 116 volts between each of the outside mains and the neutral main, and 232 volts between the two outside wires. The potentials 116 and 232 were formerly produced by two generators, Fig. 155, connected between the two legs of the circuits. At

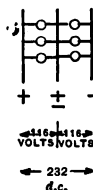

FIG. 154.—Edison  
Three-wire Sys-  
tem.

present, the three-wire system is produced by using a rotary converter, which charges a storage battery to a potential of 270 volts, the neutral feeder being connected in at the middle point, as in Fig. 156. End cells are used in connection with lay out as described earlier in the text. Various methods are used to balance the system, and these will be discussed later.

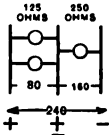

FIG. 156.—Three-wire System (Converter).

### Theory of the Three-wire System.—In

Fig. 157, two 116-volt lamps are shown connected in series with the 232-volt circuit. As both of these lamps have the same resistance, the potential will distribute itself so that there is 116 volts difference of potential across each lamp. Suppose a second pair of lamps be

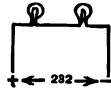

FIG. 157.—Principle of Three-wire System.

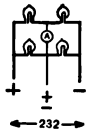

FIG. 158.—Principle of Three-wire System.

connected across the circuit, as in Fig. 158, they will likewise light up to full intensity. If the central portion of this circuit midway between each lamp be connected with an ammeter in circuit, no deflection of the ammeter will occur, as the potential across these two points is the same, a current of electricity

only flowing when there is a difference of potential. Continuing the neutral, in Fig. 158, to the bottom of the figure, it may be designated as  $\pm$ , meaning plus or minus, the symbol always used for the neutral feeder. If we measure the potential between the neutral feeder and either the plus or the minus terminal, a potential of 116 volts will be noted. When the system is balanced, with the same number of lamps on each side, no interchange of current takes place in the neutral feeder, and no current

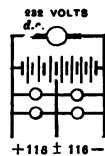

FIG. 159.—Principle of Three-wire System.

would be indicated, as in Fig. 159; but suppose that one of these lights was in series with two lamps in multiple across a 232-volt circuit, Fig. 156. The result would be a redistribution of potential, because the resistances of both sides of the system were not equal. The equivalent resistances of the two lamps in multiple would be much less than that of the single lamp. The potential across the single lamp would therefore be much higher than that across the two lamps, and the single lamp would burn very brightly, whereas the two lamps in multiple would burn below normal candle power, being below voltage. Another way of expressing the problem would be to say that all of the current passing through the two lamps would have to pass through the single lamp. Suppose that the equivalent resistance of two 16-candle-power carbon filament lamps of approximately 250 ohms placed in parallel to be 125 ohms (this is only approximately correct, as the resistance of the lamps when burned below voltage would be slightly larger), the distribution of potential would be, as shown in Fig. 156, 160 volts across the single lamp and 80 volts across the two lamps.

If an unbalanced system of this kind be connected through the neutral feeder *A*, Fig. 160, to the neutral point of a three-wire battery system having a constant potential of 120 volts on each side of the system, there would be immediately a normal redistribution of potential across each leg of the system, and all lamps would burn with normal illumination. The additional current required by the unbalance in the system would be supplied by the storage battery, the cells on the unbalanced side of the system supplying the additional load. The ammeter *A* will indicate this unbalance.

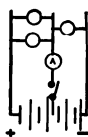

FIG. 160.—Principle of Three-wire System.

It is obvious, therefore, that in the three-wire system no current flows in the neutral feeder when the system is balanced, and whenever there is an unbalance the neutral feeder carries the difference. If the system were completely balanced, it is evident that by supplying 240 volts to the outside mains the neutral could be dispensed with; the amount of copper required would be 50% of that required if a two-wire system were to supply the same energy at 120 volts. In addition to this, 50% of the energy dissipated would be saved. This condition in practice, however, is not stable, hence it is always necessary to run at least a small neutral feeder. In practice there might be 4 concentric feeders (a concentric feeder is a two-wire feeder having both conductors stranded, one inside of the other and separated by insulating material, the whole being inclosed in an insulated lead sheath) of 1,000,000 cm., carrying 240 volts potential to a distributing point. It would be necessary to run at least one 1,000,000-cm. feeder as a neutral to produce the three-wire system. For ordinary commercial work it is quite a problem to keep both sides of the system balanced, for in some cases, where theaters have abandoned isolated plants for the Edison Three-wire System, the conditions are difficult to meet and occasionally they require the installation of extra neutrals. Although the load on a three-wire system may be completely balanced, it sometimes happens that return feed of some railway company through the neutral feeder will cause an artificial unbalance — the  $IR$ -drop in the neutral feeder causes this condition.

**Experiment 66.** Make a set-up, as shown in Fig. 161, consisting of a three-wire lamp board containing three 16 c.p. lamps on each side connected up to a three-wire Edison system having an ammeter in the neutral feeder. Have a switch connected in series with the ammeter. Turn on

all the lamps, open the neutral switch *B*, and notice that all lamps burn at normal candle-power, provided they are all new. Turn off one lamp on one side of the system and notice that the two other lamps on the same side burn brighter than do the three lamps on the opposite side. Now turn on the lamp previously turned off, and turn off a lamp on the opposite side, noting that the effect is the same as before, except that the luminosity of the lamps has reversed. Turn off another lamp on the same side, and notice that the effect of unbalance increases. When the greatest unbalance occurs, close switch *B*, and notice that the lamps light to normal candle power. Project the ammeter on the screen and repeat the experiment in a slightly different manner. This projecting ammeter should have a zero at the middle of the scale. When switch *B* is closed and all lamps are out, turn them all on. Then turn off one lamp, noting the deflection of the ammeter, which will be approximately .5 ampere. As now the neutral switch is connected, all of the remaining five lamps burn at equal candle power. This .5 ampere is being carried by the neutral feeder and represents the amount of unbalance in the system. Turn off two lamps on the same side, and notice that the deflection is now twice as great. Turn off three lamps, and the deflection is three times as great, all of the current for the remaining three lamps on the other side of the system being supplied through the neutral feeder. Turn on one at a time the lamps that were turned off, and notice that the pointer of the ammeter now comes back to zero. Now turn off one of the lamps on the opposite side, and notice that the deflection of the ammeter is reversed, the deflection being .5 ampere in the opposite direction. In this way it is possible to demonstrate to good advantage that when the system is balanced, no current flows in the neutral wire, and also that the amount and direction of the current flow in the neutral wire depends upon the extent and location of the unbalance in the system.

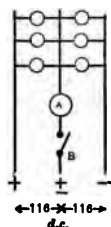

FIG. 161.— Experiment on Three-wire System.

The National Board of Fire Underwriters will not consent to the installation of series multiple systems of illumination, owing to the redistribution of potential which occurs when some of the lamps are burned out and the possible danger arising from too big a voltage on the

remaining lamps. It is undesirable to extend two branch circuits from a single cut-out with only a common neutral, as in Fig. 162, for in case this neutral fuse blows out, a series multiple system results, the two branch circuits being in series with each other. The system to employ in such cases is that shown in Fig. 163, in which a separate neutral fuse is provided for each circuit. This is the system recommended by the National Board of Fire Underwriters.

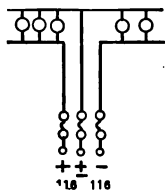

FIG. 162. — Old Style Branch Circuits.

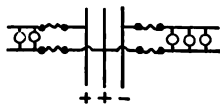

FIG. 163. — Approved Branch Circuits.

FIG. 162. — Old Style Branch Circuits. in Fig. 163, in which a separate neutral fuse is provided for each circuit. This is the system recommended by the National Board of Fire Underwriters.

### QUESTIONS

1. How does the three-wire system compare with the two-wire system?
2. Why should the neutral of a three-wire system be fused heavier than either of the outside terminals of the circuit?
3. Assume a three-wire system balanced. What effect will stray currents of electricity passing through the neutral feeder have upon the potential across both sides of the system?
4. What would be the effect of connecting a 118-volt lamp or a 150-volt voltmeter to the 240-volt terminals of a three-wire system?
5. Why are direct current motors of large capacity operated from 240 volts instead of 120 volts?
6. Explain how a switch could be arranged so as to change over a three-wire system to a two-wire system.
7. How is the three-wire system produced?
8. Explain the operation of a balancer. Why are the field windings of each machine placed in parallel with each other's armature circuit?
9. Why is it necessary in a grounded three-wire system to use care in handling either of the 240-volt terminals in the vicinity of water pipes?
10. How can a three-wire lamp board be connected so that it can be used for a two-wire load?

## CHAPTER VIII

### ELECTRICAL MEASUREMENTS

**Ammeter-Voltmeter Method of Measuring Resistance.** — The direct, or ammeter-voltmeter, method of measuring resistance is probably more generally used than any other for the measurement of resistance. This method employs two instruments, an ammeter and a voltmeter, which are connected up to the resistance, the ammeter in series and the voltmeter in multiple, the resistance being connected across the terminals of a source of potential, as in Fig. 164. With a series connection the same current passes through all of the devices forming the circuit, whereas with a shunt connection the devices are in multiple, the path of the current being divided. The terms *multiple* and *shunt* are synonymous.

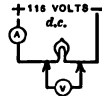

FIG. 164. —  
Ammeter-Voltmeter Method  
of measuring  
Resistance.

**Experiment 67.** As in Fig. 164, connect an ammeter in series with a 16-candle-power lamp to a 116-volt source of direct current potential. Measure with a voltmeter the difference of potential across the terminals of the resistance. In this case the potential will be the same as the potential of the service, since there is practically no drop in the short leads used and in the ammeter. Calculate the resistance from the Ohm's law formula

$$R = \frac{E}{I - \frac{E}{R'}}$$

This formula is a modification of Ohm's law, where  $R$  = the resistance of the lamp,  $I$  = the current passing through



the circuit, and  $E$  = the potential difference.  $R'$  is the resistance of the voltmeter, which in the Weston type of instrument is always given on the cover of the box. It will be noticed in this formula that the current which passes through the lamp, as well as the slight current passing through the voltmeter, is represented by the ammeter reading  $I$ . The current which passes through the voltmeter must necessarily be subtracted from this current value to determine the true current value passing through the lamp. The current value passing through the voltmeter is obviously equal to the potential difference  $E$  across the terminals of the voltmeter (the same as that across the lamp), divided by the voltmeter resistance  $R'$ . If the resistance of the voltmeter is 15,000 ohms, and the voltage of the service is 120 volts,  $\frac{120}{15000}$  is a very small quantity, and under ordinary circumstances, as when measuring a resistance of a few hundred ohms, may be neglected. The formula, neglecting the  $E/R'$ , then reduces to the ordinary form  $R = E/I$ ,  $I = E/R$ ,  $E = IR$ . If, instead of a low resistance, a resistance of 2000 ohms were measured in this method, it is evident that a large error would be introduced by neglecting to consider the current which passed through the voltmeter.

**Problem.** Given the formula  $R = \frac{E}{I - \frac{E}{R'}}$ , a voltmeter resistance of

15,000 ohms, a source of potential of 120 volts, calculate the error introduced in neglecting the quantity  $E/R'$  in measuring resistances of 500, 1000, 1500, 5000, 10,000, 15,000 ohms.

**Measurement of the Resistance of a Voltmeter.** — The resistance of a voltmeter may be readily determined by connecting in series with a voltmeter and a source of constant potential an adjustable resistance, Fig. 165. If the resist-

ance be adjusted until the voltmeter reading, indicating the service voltage, falls one half, the resistance will be equal to the resistance of the voltmeter.

This may be explained either on the principle that, having doubled the resistance of the circuit, the current passing through the voltmeter and the corresponding deflection

has been reduced one half, or on the basis that the voltmeter indicates the potential difference across its own resistance, and, having halved the voltage by doubling the resistance, the deflection reduces to one half.

**Experiment 68.** Connect a voltmeter to a source of potential and read the voltage indicated. Connect an adjustable resistance, such as a plug resistance box, in series with it, and adjust the resistance until the deflection falls one half. Calculate the resistance of the voltmeter.

**Problem.** — With a 150-volt voltmeter, having a resistance of 2000 ohms, what current will pass through the voltmeter to produce full scale deflection?

If an additional binding post be placed on this voltmeter, as in Fig. 166, tapping in beyond the main resistance of 2000 ohms so as to make it a double scale voltmeter, how much resistance would have to be inserted in series with the suspension of the voltmeter, Fig. 167, provided the resistance of the suspension was 60 ohms, so that the voltmeter would deflect a full scale deflection with 3 volts applied to the terminals + and 3?

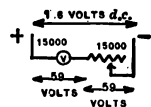

FIG. 165. — Measurement of Resistance of Voltmeter.

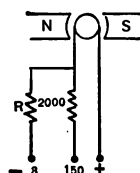

FIG. 166. — Weston Voltmeter Circuits (station instrument).

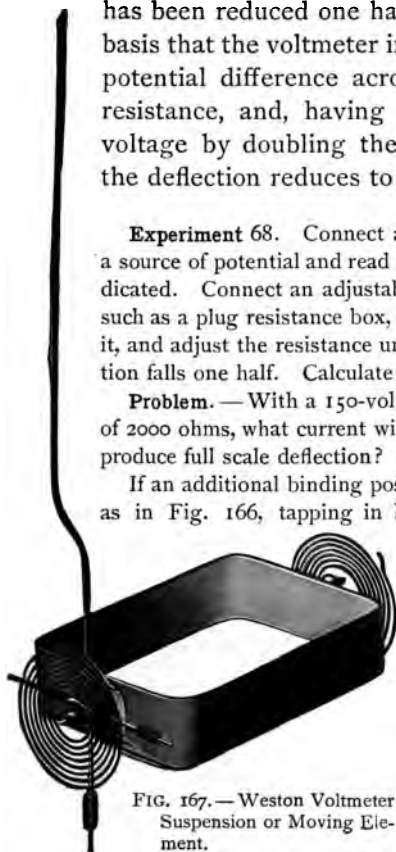

FIG. 167. — Weston Voltmeter Suspension or Moving Element.

**Note.** In changing over such a voltmeter, care should be taken to connect the new resistance in the circuit beyond the old resistance, near the suspension, and also to use a wire for this new resistance which will have a negligible temperature coefficient, such as 1ala wire.

**Voltmeter Method of measuring Resistances.** — Resist-



FIG. 168. — Measuring Resistance with Voltmeter.

ances of large magnitude, from 1000 to 1,000,000 ohms, may be accurately measured by placing them in series with a voltmeter of known resistance, Fig. 168, noting the drop in potential on the voltmeter from so doing, and calculating the resistance according to a simple proportion.

**Experiment 69.** Connect a high resistance in series with a 120-volt direct current source of supply. Short-circuit the resistance and note the voltmeter reading  $e$ . Remove the short circuit, and read the new voltage reading  $e'$ ;  $e - e'$  represents the voltage across the resistance, and  $e'$  represents the voltage across the voltmeter. According to the principle that in a series circuit the distribution of potential is proportional to the resistance of the circuit if the current be continuous, the resistance may be calculated.

$$e' : e - e' :: R : x.$$

**Comparison of Resistances with Voltmeter.** — An unknown resistance may be determined in terms of a known resistance by connecting both resistances in series with each other and a suitable source of potential, and measuring with a voltmeter the relative differences of potential across the terminals of the two resistances, the value of the resistances being to each other as their relative differences of potential.

**Experiment 70.** Connect a 16-candle-power lamp in series with a high resistance voltmeter, about 15,000 ohms, and a source of potential such as a 116-volt direct current Edison service. Why does the lamp not light and why does the needle of the voltmeter fall only a scarcely distinguishable amount from its position when no lamp is in the circuit?

The reason that two resistances may be measured in the simple way, Fig. 169, is to be explained by considering their relative potential and current relations. The same current  $I$  passes through both resistances, as they are in series with each other. The voltage current relations of one resistance will be  $I = E/R$ . For the other resistance they will likewise be  $I = E'/R'$ . As the current values  $I$  are the same, the following relations hold:

$$I = E/R, I = E'/R',$$

$$E/R = E'/R', \text{ or } E : E' :: R : R'.$$

This method is particularly useful in cases where it is impossible conveniently to place an ammeter in series with the circuit, as in testing the bonds of railway tracks. The drop in potential across the bond is measured with a voltmeter, and the drop in potential across a length of track such that the readings will be the same is determined. If this value is greater than 6 feet of track, the bond is defective. The bond is a copper conducting strip placed across the joints in tracks spanning the fish plate to prevent the current from passing through the plate and the retaining bolts.

**Calibration of an Ammeter.**—A convenient standard resistance to use in connection with the calibration of ammeters is shown in Fig. 170. It consists of 1 ohm of Krupp resistance wire, coiled up in a helix. The object of using this wire is that it has a very low temperature coefficient. A standard resistance, as in Fig. 170, should have four terminals,  $A, B, C, D$ .  $A$  and  $B$  are the current, and  $C$  and  $D$  are the potential, terminals. The current terminals  $A$  and  $B$  are placed in



FIG. 169.—Showing Distribution of Potential.

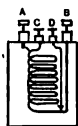

FIG. 170.—Standard Resistance.

series with the circuit, as in Fig 172, and the terminals *C* and *D* lead off to the voltmeter or whatever potential device may be used. Between the terminals *C* and *D* is included the standard resistance. In connecting the terminals *C* and *D* to this standard resistance and in soldering the connections, the wires should be coiled away from each other, as in Fig. 171, so that the potential points will be definitely located.



FIG. 171.—Method of connecting Contacts.

To calibrate an ammeter of low range the ammeter should be connected in series with an adjustable resistance to regulate the circuit, a standard ohm, and the service. A standard voltmeter is connected to the potential terminals of the standard, and the difference of potential is noted. If the standard resistance is 1 ohm, the ammeter and voltmeter readings should coincide for  $I = E/I$ . If the range of the ammeter is from 5 to 75 amperes, a lower resistance standard may be used. The standard should be immersed in kerosene oil, so that its temperature will remain constant.

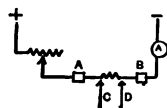

FIG. 172.— Potential Taps.

**Experiment 71.** Make set-up as in Fig. 172, using a low range ammeter, about 5 amperes, and the low voltage scale of a voltmeter, 3 or 5 volts. Also use a standard resistance and an adjustable resistance, which may be a lamp board. A three-wire lamp board is convenient for laboratory work, one side of the board being used at a time, as in Fig. 173, or two sides being used by putting in a jumper, as in Fig. 174. Vary the load on the ammeter, reading the voltage and current values, and plot a calibration curve.

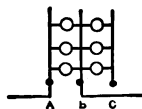

FIG. 173.— Lamp Board.

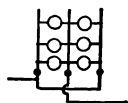

FIG. 174.— Lamp Board.

**Calibration of Ammeters, Series Method.**— For central station work it is customary in checking ammeters simply to

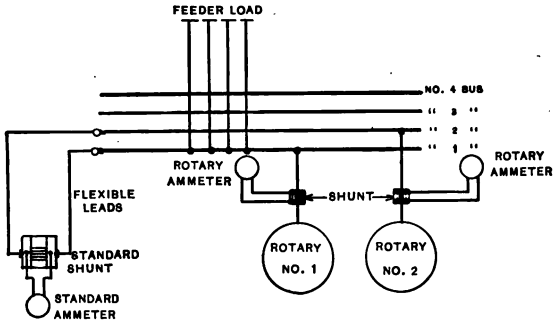

FIG. 175.— Calibrating Rotary Ammeter.

place another ammeter in series with the one being tested, as in Figs. 175, 176, and to check the two instruments

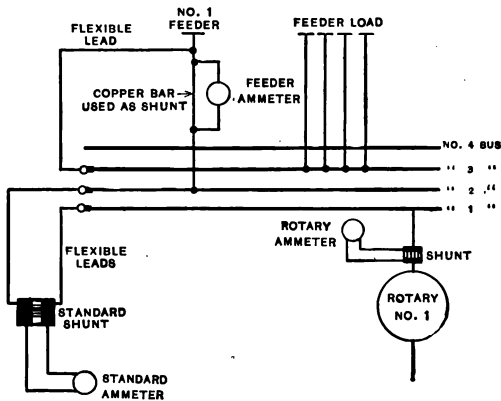

FIG. 176.— Calibrating Feeder Ammeter.

against each other. In the laboratory a suitable adjustable resistance must be placed in series with the meters. In practice this is not necessary, as by properly making the bus

connections and inserting a jumper in which is the standard ammeter, the feeders can be arranged on various busses so that only the feeder or the converter containing the ammeter to be checked will be in series with the test ammeter.

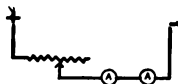

FIG. 177. — Calibrating Ammeters in Laboratory.

**Experiment 72.** Connect two ammeters in series with an adjustable resistance and the service, as in Fig. 177, one being the standard ammeter. Vary the adjustable resistance, and check the two meters against each other.

**Calibration of a Voltmeter.** — The simplest way of calibrating a voltmeter is to place it in multiple with a standard voltmeter which may be connected to a variable source of potential as a storage battery, Fig. 178, or a number of dry batteries connected in series. The voltmeter may also be checked against an ammeter by means of a standard ohm, in the reverse manner to Experiment 71, or the voltmeter may be checked against a standard cell by means of a potentiometer; the latter is the most accurate method.

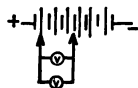

FIG. 178. — Calibrating a Voltmeter.

**Potentiometer Method of calibrating a Voltmeter.** — As the potentiometers made by the various manufacturers here and abroad differ in details, no attempt will be made to describe the individual circuits, which may be readily understood if the general principle of operation of all potentiometers is understood. In Fig. 179 is shown a potentiometer, and in Fig. 180 the circuits of the same as made by the Leeds and Northrup Company.

An elementary diagram of a potentiometer is shown in Fig. 181. The apparatus necessary to make the calibration consists of a standard cell, a galvanometer, a variable resistance such as a resistance box with suitable side contact



FIG. 179. — Leeds and Northrup Company Potentiometer.

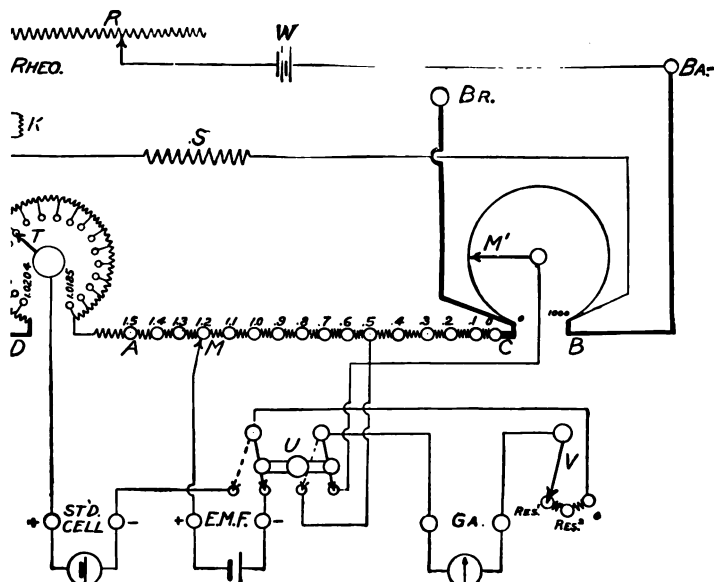

FIG. 180. — Circuits of Leeds and Northrup Company Potentiometer.



switches, a constant source of potential such as a storage battery, and a voltmeter. For a beginner it is desirable to

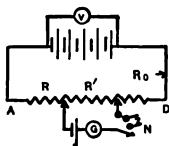

FIG. 181. — Diagram of Potentiometer Circuits.

use a storage battery or a number of dry batteries connected in series as a source of potential, although an experienced man may use a direct current lighting circuit that is slightly variable and obtain the same results.

An example of the operation of a potentiometer may be given as follows. For the standard cell circuit a suitable resistance is chosen, such as 1000 ohms. A value of 5000 to 10,000 ohms is preferable, but this value is selected to simplify calculations. Suppose, after consulting the temperature of the standard cell and applying the correcting formula, it is found that the potential of the cell is 1.4234 volts at room temperature. A resistance of 1423.4 ohms is inserted between the contacts *B* and *C* on the potentiometer, Fig. 182, causing a distribution of potential of 1 volt per 1000 ohms over the resistance included between these two points when the standard cell connected in series with the galvanometer is connected between these two points. Suppose that it is desired to calibrate the voltmeter at 40 volts on its scale. This would call for a resistance of 40,000 ohms in the battery circuit to which the voltmeter is attached, in order to obtain the same distribution of potential, 1 volt per 1000 ohms, as in the standard cell circuit, both sources of potential being connected to different parts of the same resistance, as in Fig. 181. In some potentiometers, as that of Hartman and Braun of Germany, resistances of  $9 \times 100$  ohms and  $9 \times 1000$  ohms are in-

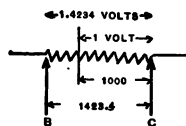

FIG. 182. — Standard Cell Circuit.

serted at the points  $B$  and  $C$ , Fig. 182, suitable contact switches moving over them so as to facilitate the adjustment of the resistance in the standard cell circuit. In this case, in setting for 1423.4 ohms, one contact is slid over to the 1000 mark, the other contact is slid over to the 400 mark, and resistance plugs of 23.4 ohms are taken out between contacts  $B$  and  $C$ . Care must be taken in the use of this box to remember that if a total of 40,000 ohms is to be included in the external circuit, there is already in the circuit  $9 \times 100$  and  $9 \times 1000$  or 9900 ohms, irrespective of where contacts  $B$  and  $C$  may be placed; and when the setting is made as in the above example, there is a total of 9924.4 ohms in the external circuit.

For a setting of 40 volts it would require an additional resistance of  $40,000 - 9924.4 = 30,075.6$  ohms. This resistance is inserted in the adjustable resistance  $R$ , outside of the standard cell circuit, Fig. 181. When these adjustments have been made, the contact switch  $N$  is closed, placing 100,000 ohms in series with the galvanometer circuit. If the voltmeter reading is correct at 40 volts, no deflection of the galvanometer will occur, as the difference of potential across the terminals of the external resistance 1423.4 ohms will be 1.4234 volts, equal to the voltage of the standard cell which it is opposing. Suppose, however, that the voltage of the circuit was greater or less than 40 volts, although the voltmeter indicated 40 volts, then the difference of potential on the external circuit would not equal that of the standard cell, and a deflection of the galvanometer would occur. In this case the resistance in  $R$  outside of the standard cell circuit is adjusted until no deflection of the galvanometer occurs on closing switch  $N$ . (Do not leave the switch  $N$  closed longer than is necessary, in order to limit the discharge of the standard cell.) When

the previous adjustment has been made, close the switch *N* on last contact, eliminating the series resistance of 100,000 ohms. A finer adjustment of the resistance *R* in the external circuit may now be made until zero deflection occurs. If, during this performance, the resistance of the standard cell circuit has not been disturbed, the true voltage of the circuit may be obtained by dividing the total resistance of the external circuit — not forgetting the 9900 ohms which is always in the circuit with the Hartman and Braun potentiometer — by 1000 ohms, the unit of distribution of potential. In the adjustment of the box, if it has been necessary in order to balance to disturb the standard cell circuit, the following relation holds:

$$e : e' :: R : R + R',$$

where *e* = voltage of standard cell, *e'* = voltage of external circuit, *R* = resistance of standard cell circuit, and *R'* = external resistance.

**Experiment 73.** Calibrate a voltmeter by the above method.

**Calibration of an Indicating Wattmeter.** — As described on page 42 a wattmeter has two coils, a series coil and a shunt coil. These two coils are connected in the circuit in the same manner as an ammeter and a voltmeter are connected, the current coil being in series and the potential coil being in multiple, as in Fig. 183, where a wattmeter is shown connected up so as to measure the energy consumed by a 16-candle-power lamp, about 50 watts. Wattmeters are usually constructed so as to carry a fixed maximum current through their current coils. A 300-watt wattmeter may have a current-carrying capacity of 3 amperes, although for short intervals it may carry as high as 6 amperes without over-

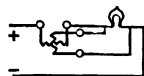

FIG. 183.— Indicating Wattmeter Circuits.

heating. A standard ammeter may be placed in series with the current coil, and a standard voltmeter may be shunted across the potential coil, the product of both instruments indicating the true watts against which the reading of the indicating wattmeter may be checked, Fig. 184. In order to vary the reading of the wattmeter, it is necessary to vary the amperes or the volts. A good method is to maintain the current constant, and then to vary the potential, as in Fig. 185. Here the potential is varied by having an adjustable resistance in series with a lamp, shunting the lamp to the potential coil and the standard voltmeter. Varying the resistance in series with the lamp will vary the potential.

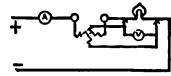

FIG. 184. — Calibration of Indicating Wattmeter.

**Experiment 74.** Calibrate a wattmeter, using an ammeter and a voltmeter, and vary the potential, Fig. 185. Obtain several readings over the whole scale of the instrument. Change over the instrument terminals and take the average of two values.

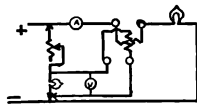

FIG. 185. — Calibration of Indicating Wattmeter.

**Experiment 75.** Calibrate a wattmeter by checking against another wattmeter, as in Fig. 186, varying the amperes with an adjustable resistance such as a lamp board.

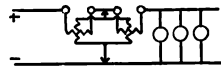

FIG. 186. — Calibration of Indicating Wattmeter.

### Wheatstone Bridge Method of Measuring Resistance. —

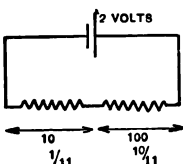

FIG. 187. — Principle of Wheatstone Bridge.

Given two resistances of 10 and 100 ohms connected in series to a dry battery of 2 volts as in Fig. 187, the 2 volts will distribute itself over these two resistances according to Ohm's law in the ratio of  $\frac{1}{11}$  of the potential across the 10 ohms and  $\frac{10}{11}$  of the potential across the 100 ohms. Suppose that the previous combination be shunted by

two additional resistances in series of 20 ohms and 200 ohms, Fig. 188, then the potential 2 volts will likewise distribute

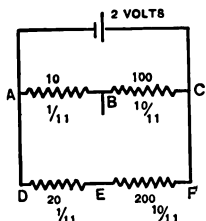

FIG. 188. — Principle of Wheatstone Bridge.

itself over these two resistances in the ratio of  $\frac{1}{11}$  of the voltage across the 20 ohms, and  $\frac{10}{11}$  of the potential across the 200 ohms. The distribution of potential in a series direct current circuit is always proportional to the resistance of the parts of the circuit. In the above case

there will be the same *difference of potential* across the resistance *AB* as across the resistance *DE*, namely  $\frac{1}{11}$  of 2 volts. If a galvanometer is connected through a switch between these two resistances, as in Fig. 189, and a switch in the galvanometer circuit is closed, no deflection of the galvanometer will occur, as there would be no potential difference across the galvanometer terminals, causing no current flow. Suppose, however, that the resistance *DE*, Fig. 189, was 100 ohms instead of 20 ohms, the difference of potential across *DE* would be greater than that across *AB*, and a deflection of the galvanometer would result, owing to

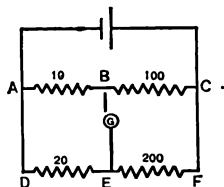

FIG. 189. — Principle of Wheatstone Bridge.

a difference of potential between the points *B* and *E*. If the resistance *DE* was changed from 100 ohms to 10 ohms, the deflection of the galvanometer would be in the opposite direction. When the resistance *DE* is variable, it can be adjusted until no deflection of the galvanometer occurs, in which case the ratios of potential would be  $AB : BC :: DE : EF$ . If *AB* was 10 ohms, *BC* was 100 ohms, *DE* was 25 ohms, *EF*, or *x*, would have to be 250 ohms. A *Wheatstone's Bridge* consists of this combination of 4 resistances connected in closed series formation, having a battery con-

nected to two opposite junctions, and a galvanometer connected to the two remaining opposite junctions. The arms  $AB$ ,  $BC$  are termed the ratio arms. The ratio arms and an adjustable resistance, Fig. 190, are usually made up in the form of a box termed a Post-office Box, or a bridge-testing set. The ratio arms, Fig. 191, of a post-office box consist of two sets of resistances of 10, 100, 1000 ohms respectively, as arms  $A$  and  $B$  in the figure. By withdrawing plugs in both sides of this box, the ratio of both sides may be readily changed. The box contains an adjustable resistance  $C$ , whose resistance may be made anything from .1 ohm up to 20,000 or more ohms by suitably manipulating the plugs.

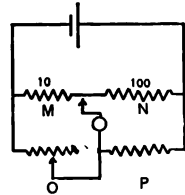

FIG. 190. — Principle of Wheatstone Bridge.

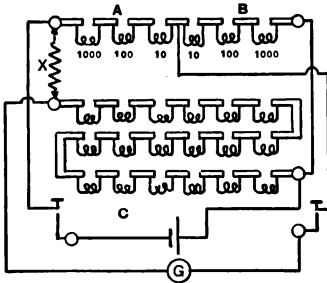

FIG. 191. — Post-office Box.

One extremity of this adjustable resistance may be connected to one end of the ratio arm  $B$ , and the other end of the adjustable resistance  $C$  may be connected to one terminal of the unknown  $x$ , the other terminal of the unknown being connected to one extremity of the ratio arm  $A$ . This gives four resistances in series. Two

switches are provided on the instrument so that the battery can be connected to two junctions, skipping a junction through a switch, and the galvanometer can be connected to the two remaining junctions, skipping a junction, through a switch. To operate the box a suitable ratio is taken out in the ratio arms, such as 10 and 100 ohms. Proper connections are made between the unknown  $x$ , the resistance, the battery, the galvanometer, and the jumper connection.

A *guess* resistance of about 200 ohms is taken out in the adjustable resistance  $C$ , and the battery and galvanometer switches are closed for an instant. If the experimenter is



unfamiliar with the method, it is well to shunt the galvanometer with a shunt of about 20 ohms, as in Fig. 192. The deflection of the galvanometer is noted, and a readjustment of the plugs is made, gradually reducing the magnitude of the deflection. When the deflection moves in the opposite direction, it will be known that too much resistance has been changed. The resistance of the unknown is calculated from the previous data, and the ratio arms may then be changed if desired so as to give greater refinement still, using a ratio of 10 : 1000 instead of 10 : 100. In setting up a resistance to measure by the Wheatstone bridge method, it is not necessary to have a special resistance box, as any four resistances connected up in a closed series formation, as in Fig. 193, will serve the purpose, provided the resistances have the proper range. It is well to bear in mind that the battery should be connected on two junctions not adjoining and the galvanometer on the two remaining junctions. It is also well in making the preliminary connections to have some resistance in each of the arms so as not to short-circuit the battery or cause excessive deflection of the galvanometer with accidental closing of the switches. When through with the resistance box, always return the plugs to their proper positions, giving them a slight twist with pressure to insure good contact. This will keep the box in good condition.

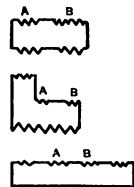

FIG. 193.  
Various Arrangements of Four-Series Resistances.

Various modifications of the Wheatstone bridge are in use, known as the slide wire bridge, the roller bridge, the

Carey-Foster Bridge, and the Thomson Double Bridge. The Wheatstone bridge is accurate for measuring resistances from about 2 ohms to 200,000 ohms. Below 2 ohms to .1 of an ohm, the direct method may be used, substituting a galvanometer for a voltmeter. From .1 of an ohm down, the Thomson Double Bridge may be used. It is possible with this bridge to obtain an accuracy of .01% in measuring resistances as low as .05 ohms. Directions for using the Thomson Double Bridge are given later.

**Slide Wire Bridge.**—The slide wire bridge differs from the ordinary form of Wheatstone bridge in that a fixed resistance wire is substituted for the ratio arms. A sliding contact connected to one terminal of the galvanometer moves over this wire. For the adjustable resistance is substituted a fixed resistance  $O$ , as in Fig. 194, the unknown resistance being inserted in the same way as in the ordinary bridge. The battery connection is made across the two extremities of the stretched wire, and the other galvanometer terminal is connected midway between the unknown and the fixed resistance.

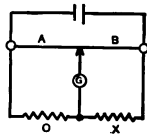

FIG. 194.—Slide Wire Bridge.

To measure the unknown, the sliding contact is moved over the stretched wire until a balance occurs. A scale accompanies the stretched wire so that, when a balance occurs, the ratio of the two parts,  $A$  and  $B$ , may be noted. The ratio of these two parts will be the same as the ratio of their relative resistances, the wire being of uniform resistance. The value of the unknown is then found from the simple proportion :

$$A : B :: O : x \text{ where } x \text{ is the unknown.}$$

**Experiment 76.** Stretch a German silver wire between two contact points, as in Fig. 194, and insert a known and an unknown resistance, such as a 16-candle-power lamp. Calculate resistance of lamp.



**The Wire Roller Bridge.** — This form of bridge is similar to the slide wire bridge, except that the slide wire is coiled upon a drum, as in Fig. 195 *a*, both extremities of the wire being fastened to metal pegs which are electrically connected to a brass axle passing through the drum. This axle is divided into two parts at its center, so as to separate, electrically, the ends of the wire. Pressing upon the axle are two upright springs, which continue the electrical connections to the two binding posts, *P* and *R*.

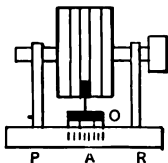

FIG. 195 *a*. — Wire Roller Bridge.

The stretched wire, which may be placed in the circuit by connecting to the binding posts *P* and *R*, constitutes the ratio arms, Fig. 195 *b*. A small contact wheel, electrically connected to the binding post *N*, moves over the slide wire, sliding along an axle supported in spring supports. Between the binding posts *P* and *R* are inserted a standard resistance and the unknown resistance, the battery connections and galvanometer connections being as shown in the figure.

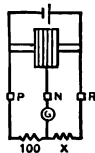

FIG. 195 *b*. — Wire Roller Bridge.

Sometimes the standard resistance, consisting of three resistances, 10, 100, and 1000 ohms, is mounted in the base of the roller bridge. With this method, Fig. 196, it is only necessary to insert the unknown between the two binding posts provided for it. It is sometimes convenient to substitute for the battery the secondary terminals of an induction coil, Fig. 197, the induction coil being operated from a vibrator and a dry battery, and to substitute for the galvanometer a telephone receiver. As the drum is turned, the alternating difference of potential of the bridge, due to unbalance, causes a slight tone in

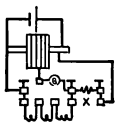

FIG. 196. — Wire Roller Bridge.

the receiver. With the continued turning of the drum, this tone gradually decreases as the point of balance is reached. When the balance point is passed, the tone increases again. The balance is set at the point of minimum sound. This method or modification of the roller bridge is particularly advantageous in measuring the resistances of electrolytes as in Fig. 197, as it eliminates the polarization e. m. f.

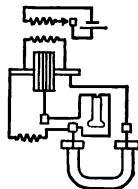

FIG. 197. — Resistance of Electrolyte.

**Experiment 77.** Compare with a roller bridge connected up with a telephone and an induction coil, as in Fig. 197, the relative resistances of copper sulphate solution and salt solution, taking the salt solution as a standard.

**Carey-Foster Bridge.** — This bridge is used for the comparison of standards. The bridge, Fig. 198, consists of four arms, *A*, *B*, *C*, and *X*. *A* and *B* are usually equal, of 10 ohms each in some bridges; *C* and *X* to be compared should be almost equal, *C* being another standard resistance. To one extremity of *C* and one extremity of *X* is connected a stretched standard wire, whose resistance per unit length is accurately known. A movable contact *N* is slid over this wire when an adjustment is being made. Two commutating switches are provided, one for commutating or reversing the battery connections to eliminate thermal effects, the other to substitute the resistance *C* for the resistance *X*. Four observations are taken on the galvanometer, connected in the regular bridge manner, balancing each time. Two of these readings are taken with *C* and *X*, as in the diagram, the battery being commutated after the first reading. The average of these two values on the vernier at *N* gives setting *S*. The standards are then commutated, *X* being substituted for *C*,

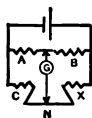

FIG. 198.  
Carey-Foster  
Bridge.

and two more readings taken, the battery being commutated after the first reading. This will give an average reading of the two vernier settings of  $S'$ . The difference between  $S$  and  $S'$  represents a certain length of the slide wire which is equal, at that particular temperature, to the difference in the resistances of the two standards. If  $\phi$  is the coefficient of resistance of the slide wire, the result may be obtained from the following expression :

$$X = C + \phi(S' - S).$$

In using this formula care must be taken to see that the standard and  $X$  have the correct relation to each other. If they changed places in the set-up, the formula would become

$$X = C - \phi(S' - S).$$

**Experiment 78.** Compare a standard ohm with a similar resistance, taking care to correct the standards for temperature.

**Thomson Double Bridge.** — The Thomson double bridge is a modification of the Wheatstone bridge, having four resistance arms connected up in a manner similar to the ordinary bridge. Between the unknown resistance and the adjustable resistance is placed a heavy contact to reduce the resistance of the joint to a minimum. This connection is shunted by two other resistances having the same ratio as the ratio arms. The galvanometer connects midway between these two resistances and the two ratio arms. If  $A$  and  $B$  are the ratio arms, if  $C$  and  $D$  are these two auxiliary resistances, and  $E$  is the value of the adjustable resistance when a balance is made, the following expression should hold,

$$A : B :: C : D :: E : X.$$

**Insulation Test.** — When large quantities of electric light wire are used by the operating companies, it becomes nec-

essary to test the insulation at frequent intervals to discover defects in manufacture. A simple method of doing this is to place a sensitive galvanometer in series with the insulation and a source of potential, noting the deflection of the galvanometer. Knowing the constant of this instrument, the resistance may be readily calculated.

**Experiment 79.** Coil up about 500 ft. of No. 16 insulated copper electric light wire, bring out the two free ends, and solder them together. Place this coil in a vessel containing a salt solution and introduce a metal electrode into the bottom of the vessel. Place the two electrodes in series with a 240-volt direct current source of potential, and a galvanometer, taking care to short-circuit the galvanometer so as to prevent an excessive kick of the galvanometer owing to the charging capacity effect of the cable. After a time, open the short-circuiting switch, and note deflection of the galvanometer. If the galvanometer is of the ballistic type, this deflection will be quite small. The resistance of the insulation should be quite high, 240 megohms per mile at least. A megohm is a million ohms. Having calculated the resistance of the insulation by noting the deflection, applying the constant of the galvanometer to determine the equivalent current value, and applying Ohm's law, calculate the resistance of one mile of wire. In so doing, do not forget that insulation is in parallel and therefore that the resistance per mile will be less than the resistance of 500 feet.

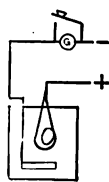

FIG. 199.  
Insulation  
Test.

**The Galvanometer.** — The galvanometer is one of the most sensitive instruments in use for measuring current. In construction it is quite similar to a Weston voltmeter, except that a flexible suspension is substituted for the spiral springs, and the resistance of the instrument is low, varying from 60 to 100 ohms. Referring to Fig. 200, it will be noted that the instrument consists of steel magnets surrounding a movable suspension. Inside of some suspensions is placed a soft iron core, which tends to facilitate the passage of lines of force. In the ballistic type of

instrument this core is eliminated. A telescope is used in connection with the galvanometer, a set of cross hairs being placed across one of the lenses of the telescope.

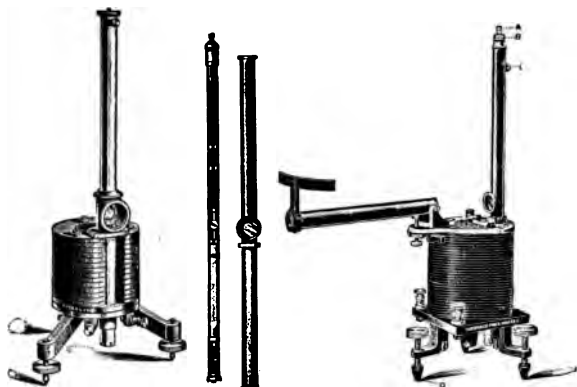

FIG. 200. — Galvanometer. (O. T. Louis Co., N. Y.)

Upon the telescope is also mounted a scale which is reflected from a small mirror placed on the galvanometer movement. With a deflection of the galvanometer, this scale seems to move across the field in the eyepiece, the reflection traveling.

**How to set up Galvanometer.** — To a beginner who is unfamiliar with a galvanometer, its setting up affords some difficulty, especially as the fiber of the galvanometer is so likely to fracture. The galvanometer should first be taken from its case and mounted upon a table about two feet from the edge. The set screws should be adjusted until the instrument is perfectly level. The suspension should then be released by the releasing device on the instrument. When this is done, it will probably be noticed that the galvanometer movement will not be entirely free, but will touch upon one side. Carefully adjust the set screws until

the movement is free, taking care not to touch the fiber or the movement with the hands in any way, as the fiber is very easily broken, and very hard to repair. When the suspension is free and moves freely, point the telescope in the direction of the mirror, placing the eye on a line with the barrel of the telescope, first in a vertical, and then in a horizontal direction, scanning alongside — not through — the telescope. When this adjustment is made, look through the telescope and adjust it until the scale comes into focus. It may be that, after all of these precautions, only the mirror and not the scale may be seen through the telescope. This is due to the fact that the mirror is turned too far. In this case the suspension of the instrument must be slowly turned until the scale comes into view. A very small movement of the fiber will cause a very large movement of the mirror. After having first set it, do not shift the telescope in order to find the scale, or the finding will be impossible.

**Determination of Resistance of Galvanometer.** — The resistance of an ordinary galvanometer is about 100 ohms. A simple way of measuring the resistance of a galvanometer is to place in series with it a very high resistance, such as a graphite stick containing 500,000 ohms, and a dry battery. Note the deflection. Then shunt the galvanometer with a resistance equal to the galvanometer, in which case the deflection will fall one half. Graphite sticks are very convenient things to have in the laboratory. They can be purchased from the Dixon Crucible Company of New York for about 18 cents. They come in various sizes, anywhere from an eighth of an inch to an inch in diameter; of any resistance from a few hundred ohms to 700,000 ohms. The cost of the rods does

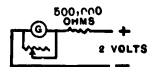

FIG. 201.—Measuring Resistance of Galvanometer.

not depend upon the resistance of the stick, but upon its dimensions. The set-up for the above experiment is shown in Fig. 201.

**Determination of the Constant of a Galvanometer.** — The constant of a galvanometer is expressed in two ways; it may mean the amperage necessary to cause one scale deflection, or it may be, as in the case of a ballistic galvanometer, the microvolts necessary to produce one scale deflection. This value is usually expressed by the symbol  $K$ . Where  $K$  means the amperes per scale deflection, it may be readily determined by placing a low potential, such as  $\frac{1}{1000}$  of a volt, across the terminals of the galvanometer, noting deflection. The resistance should then be calculated according to the previous experiment. The potential  $e$  divided by the resistance of the galvanometer  $r$  will give the current passing through the galvanometer. Dividing this quantity again by the scale deflection  $\theta$  will give the amperes  $K$  per scale deflection :

$$K = \frac{e}{r \times \theta}.$$

**Experiment 80.** Connect across the terminals of a dry battery 1000 ohms and from 1 of these ohms lead off to a galvanometer, as in Fig. 202. Usually a resistance box is used, Fig. 203, and the 1000 and 1 ohm plugs are pulled out, placing 1001 ohms in the circuit. This introduces a small error which is practically negligible. A telephone plug with a small binding post on its top may then be inserted in the 2-ohm place in the resistance box, which usually adjoins the 1-ohm position. This will allow wires to be conveniently connected both sides of the 1 ohm. See Fig. 203. Determine constant  $K$  of any galvanometer which may be convenient, using set-up as

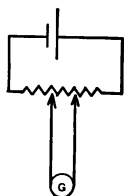

FIG. 202.  
Method of  
Obtaining  
Low Po-  
tential.

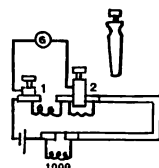

FIG. 203. — Low  
Potential Ob-  
tained.

indicated in Fig. 203. If galvanometer is very sensitive, it may be necessary to insert a greater resistance in the battery circuit than 1000 ohms in order that the galvanometer deflection will not be too great, making proper correction in formula.

**Measurement of Capacity.** — The most satisfactory way of measuring capacity with a direct current circuit is by means of the direct discharge method. The condenser under test is charged from a battery of known potential and then discharged through a ballistic galvanometer as in Fig. 204. When the switch *B* is up, Fig. 204, it makes contact with *A* and charges the condenser. When moved down, it opens the battery circuit and discharges the condenser through the galvanometer. The kick of the galvanometer should be read. Do not wait for a steady deflection. For the unknown condenser a standard condenser is then substituted with the same set-up, including battery, and experiment repeated. The relation between the two condensers will be the same as their relative deflections:

$$C : C' :: \theta : \theta'$$

where *C* and *C'* are the capacities in farads or microfarads and  $\theta$  and  $\theta'$  are the relative deflections.

**Experiment 81.** — Compare two condensers by the direct discharge method, using set-up similar to Fig. 204. If unknown condenser yields too large a deflection to be read on the scale of the galvanometer, the charging potential may be reduced by shunting off from a part of a resistance connected across the terminals of a battery. A double throw switch, Fig. 205, may be used in this experiment to rapidly substitute one condenser for another.



FIG. 205.  
Substituting  
Switch.

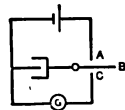

FIG. 204. — Measurement of Capacity.

**Commercial Testing Sets.** — Many forms of Wheatstone bridge are made up in compact style for commercial test-



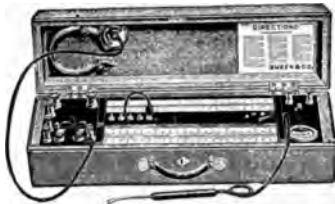

FIG. 206. — Queen Slide Wire Bridge.



FIG. 207. — Queen Acme Testing Set.



FIG. 208. — Queen Decade Testing Set.



FIG. 209. — Queen Laboratory Wheatstone Bridge.



FIG. 210. — Queen Wheatstone Bridge.

ing. These may be of the slide wire type, Fig. 206, employing a telephone receiver which clicks when the slide wire circuit is completed, or the galvanometer may be constructed as part of the instrument, as Figs. 207, 208; or the bridge may be in a simple compact laboratory form as Fig. 209; or the resistances may be multiplied on the decade principles in multiples of ten, as Fig. 210.

All of these forms of bridge may be obtained from O. T. Louis Company, 59 Fifth Ave., New York City, agents for Queen and Company.

### QUESTIONS

1. Describe the potentiometer method of calibrating a voltmeter.
2. Explain in detail the practical meaning of Ohm's law as applied to all bridge methods.
3. Draw a diagram of circuits for testing an ammeter.
4. How would you calibrate an indicating wattmeter?
5. Why is it desirable to use a short-circuiting galvanometer switch in testing a cable?
6. How would you set up a galvanometer and determine its constant?
7. Why is the Thomson double bridge so accurate for measuring small resistances?
8. What do we mean by the current-carrying capacity of wires, and why should we never send more than .2 ampere through a low resistance in a post-office box?
9. Take resistance from 500,000,000 ohms down to .005 ohm in suitable steps and give the proper measurement method to use in each case.
10. Why should you always have a few plugs out in the adjustable resistance of a bridge when you are connecting the galvanometer to the bridge circuit? Why is this also desirable in the ratio arms or battery circuit, especially if only one contact key is used?

## CHAPTER IX

### THE SHUNT MOTOR

GIVEN a motor such as in Fig. 211 (a shunt CQ motor installed on the ceiling, G. E. Co.), the question arises as to how to determine whether it is a shunt motor; if so, how the motor should be set up and how operated; how



FIG. 211. — CQ Motor installed on Ceiling.

its direction of rotation should be changed, and how its speed should be varied. Considerable information is usually given on the name plate of the machine. If it is a direct current shunt motor, the name plate will state these facts — Direct Current Shunt Motor, giving also the voltage that the motor is intended to be operated upon, the speed of the motor at full load, the current input at full load, the size or capacity in horsepower, or kilowatts, and sometimes

the number of poles. In case the motor should not be provided with a name plate, it will be necessary to distinguish first whether it is a direct current or an alternating current motor. A direct current motor always has a commutator, brushes, and separate pole pieces which can be readily counted, whereas an alternating current motor is a much simpler machine, having practically none of these characteristic features. This is especially true of induction motors, although synchronous motors possess slip rings. When it has been decided that the motor is a direct current machine, the question arises of distinguishing between a shunt motor and a series motor, the two most common types. A series machine usually has two terminals coming out from the case, whereas a shunt machine has either three or four. There are three if the direction of rotation is fixed by joining together one armature and one field terminal inside of the machine. Such observations apply to small machines up to 5 horsepower, such as a beginner would be likely to encounter. With larger series machines, such as railway motors, both armature and field terminals leave the machine, as it is necessary to vary the direction of rotation of the motor in practice.

**Testing out Circuits.** — In Figs. 211, 212 it will be noticed that four terminals come from the machine, or that the terminal block contains four outlets. Two of these outlets are armature terminals, and the other two are field terminals. As sometimes the character of the terminals is not indicated, the circuits may be tested out with a test lamp in the following way:

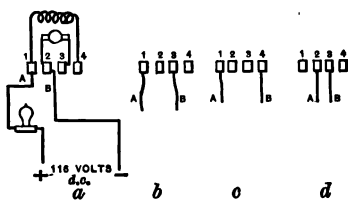

FIG. 212. — Testing out Circuits of Motor.

**Experiment 82.** Take a 16-candle-power lamp, 116 volts in a socket, and connect one terminal to the positive terminal of a source of 120 volts direct current, such as an Edison service. From the other terminal of the lamp run a lead to one of the terminals of the motor, such as terminal No. 1 in Fig. 212. Call this lead *A*. From the other Edison terminal extends a wire, which we will call terminal *B*. When the switch is closed, pressure will be upon *A* and *B*, and if brought into contact the test lamp will light. When the lamp has been tested in this manner, place leads *A* and *B* on terminals 1 and 2, as in *a*, Fig. 212, and although there is pressure upon *A* and *B*, the lamp will not light, because the circuit is open in the machine. Then place the terminals upon 1 and 3, as in *b*, Fig. 212, with the pressure on as before, and the result will be similar to that in the previous test. Now place terminals *A* and *B* on 1 and 4, as in *c*, Fig. 212, and the lamp will light *dimly*. This is due to the fact that the field winding of the motor is now in series with the lamp, and as the resistance of field circuits of small machines is about 100 to 200 ohms, and the resistance of a carbon filament of 16-candle-power hot is about 250 ohms, the voltage across the lamp terminals will be reduced proportionally. In other words, *the distribution of potential in a series direct current circuit is proportional to its resistance*. Having located the field terminals of the motor, 1 and 4, the terminals 2 and 3, as in *d*, Fig. 212, must necessarily be armature terminals. On connecting test terminals *A* and *B* to terminals 2 and 3, the lamp will light to practically full luminosity, as the armature resistance is very low. Where the dimensions of the field resistance will be of the order of 200 ohms, the dimension of the armature resistance will be .5 ohm, including brushes.

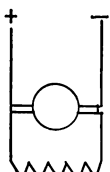

FIG. 213. —  
Shunt Ma-  
chine.

**Experiment 83.** With an ammeter and voltmeter measure the field and armature resistances of a shunt motor, Fig. 213, taking care when measuring the resistance of the armature circuit to place an additional resistance in series with it to protect the ammeter.

**Magnetic Circuit of Field Coils.** — The field circuit of a motor consists of a series of poles alternately north and south, Fig. 214, mounted upon a frame, or *yoke*. The path of the magnetic flux is from the north pole through the armature to the adjoining south pole, through the yoke back

to the north pole. This is shown by the dotted line in the figure. The function of the laminated iron core of the armature is to facilitate the passage of these lines of force. It is very important with a motor to see when connecting up the field coils that the polarity progresses regularly, namely, north and south, north and south.

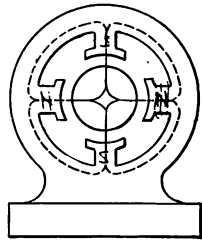

FIG. 214. — Magnetic Circuits of Motor.

**Experiment 84.** Connect up the field coils of a shunt motor to a source of potential, the armature of the motor being taken from position so that coils are accessible. Test out circuits of the excited field coils with a magnet or compass. If a magnet be not at hand, take a small bolt or a small nail of sufficient length to reach across the centers of two adjacent poles, and allowing one end to be in contact with one pole, bring the other near the adjacent pole, and if the poles are properly formed, the bolt will be quickly attracted to it, Fig. 215.

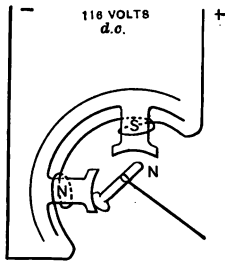

FIG. 215. — Testing out Magnetic Circuits.

**Experiment 85.** Change the order of connections as in Fig. 216, connecting coils in reverse order, and repeat the experiment. Up to the point where the bolt is not in contact with more than one pole, repulsion of the bolt will take place, but when the bolt is allowed to touch both poles, it will remain in contact. This is a simple method of testing the polarity of the field coils.

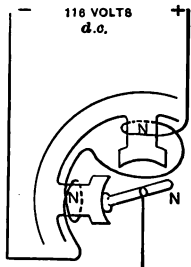

FIG. 216. — Testing out Magnetic Circuits.

**Magnetic Circuits of Armature.** — The armature of a motor is wound with loops of wire connected to the various commutator segments. When a current is passed through the armature, the core is magnetized, forming a series of poles corresponding in number to the number of

field coils. Referring to Fig. 217, a core of iron is wound with a few turns of wire, and a current of electricity is passed through it. The core will then become magnetized, having a north and a south pole. In an actual machine the distance between two sides of an armature coil is equal to the distance between the centers of two adjacent poles.

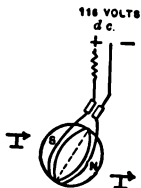

FIG. 217.—Magnetic Circuits of Armature.

**Experiment 86.** Take an armature of a 2-kilowatt machine and make a set-up, as in Fig. 217, sending a current of about 10 amperes through the armature circuit. With a compass needle pass from one side of the armature to the other, noting the change in polarity.

The current entering at one brush of a 2-pole machine passes through the winding in two directions, leaving at the other brush. Armature windings are quite extensive in number and arrangement. In many cases, however, a simple series winding is used, each loop being connected between adjoining commutator segments.

**Experiment 87.** With same set-up as in Fig. 217, change the polarity of the terminals, alternating the direction of the current through the armature, reversing its north and south poles.

**Magnetic Circuits of Armature and Field.** — The attraction of the field poles for the armature poles of a motor is the cause of its armature rotation. With a two-pole machine, as in Fig. 218, when the brushes are in position *B*, the motor with magnetic circuits as marked will rotate in a clockwise direction, the north pole of the field attracting the south pole of the armature. If the brushes be shifted over in direction *A*, the motor will operate in the opposite direction or in a counter-clockwise direction.

**Experiment 88.** Excite the field coils of a small 1-kilowatt machine and with a separate resistance in series with the armature circuit, allow-

ing just sufficient current to pass through the armature just to overcome the friction of the bearings and cause slow rotation in one direction, as in Fig. 218. Move the rocker arm carrying the brushes, first to one side and then to the other, causing the direction of rotation to change.

**Neutral Plane.** — When an armature coil is undergoing commutation, that is, when the brush is passing over adjacent commutator segments between which a coil is connected, two things happen, — the direction of the current in the coil changes and also the coil is short-circuited. When the coil is short-circuited, a spark occurs; this depends for its magnitude upon the electro-motive force generated in the coil at that instant, upon the resistance

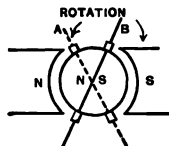

FIG. 218. — Changing Direction of Rotation.

of the complete circuit, including the coil and the brush, and upon the self-induction of the coil. The brushes are usually shifted to a point where sparking disappears, and this point is termed the *neutral plane* (see dotted line in Fig. 218). When a motor becomes heavily loaded, the armature flux tends to distort somewhat the field flux, so that the neutral plane is shifted. This necessitates shifting the brushes somewhat.

**Operating Connections.** — When a shunt motor is operating under normal conditions, the armature and field circuit are in multiple, as in Fig. 213, connected to the source of supply. Since the field resistance is comparatively high, the amount of current which would pass through the winding upon connecting it directly to the circuit would be quite small.

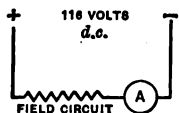

FIG. 219. — Measuring Field Current.

**Experiment 89.** Place an ammeter in series with a field circuit and a source of direct current supply, 116 volts direct current, and note the small current input. For a 1-kilowatt machine the value will be about one ampere.



When making connections to the field circuit, care should be taken to see that the main switch is open; otherwise, when making the last connection, it is quite possible to have one hand on one terminal of the machine and the other hand on the other terminal of the wire which was about to be placed under the binding post. This will put the operator's body in series with the circuit, and will tend to make him draw back, thus opening the circuit and giving him a shock due to the self-induction of the field circuit. With a 10-kilowatt machine, if the machine has been operating and is slowing down but the starting box handle has not returned and the field circuit is opened through the body, the shock is so severe that it will be felt in the arms for several days.

**Experiment 90.** Make a set-up as shown in Fig. 220, connecting the field terminals of the motor in parallel with a Weston voltmeter and a 116-volt source of supply through a switch. The voltmeter should be connected beyond the switch and so connected that it will tend to deflect backwards, that is, the positive terminal of the voltmeter should be connected to the negative field terminal. Open the switch after the fields have been excited for a time, and note the *kick* of the voltmeter needle. This induced e. m. f. is due, as previously explained, to the self-induction of the field circuit. The flux of the magnetic field in shrinking to zero cuts the turns of wire composing the field coil and generates in these interlinked wires an electro-motive force, depending for its magnitude upon the time taken for the flux to reach zero and upon the magnitude of the flux.

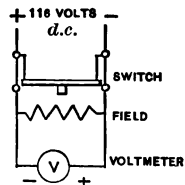

FIG. 220.—To show Induction of Field Winding.

**Armature Circuit.**—As the armature has a low resistance, it is obviously unwise to connect it directly to a circuit of 116-volt source as in the case of the field circuit without using an external resistance in series with it.

**Experiment 91.** Having connected the field circuit to the source of supply, open the main switch and connect the armature in parallel with it, through a suitable resistance, with an ammeter also in circuit. If the machine is a small unit, such as a 2-kilowatt machine, a bank of lamps forms a suitable adjustable resistance. Sufficient lamps should be turned on with the main switch closed, Fig. 221, until the motor starts to operate. If the hand be placed upon the pulley of the motor so that it cannot rotate, the ammeter needle will deflect to a maximum. If the hand be removed, the motor will start to rotate, the deflection of the needle becoming smaller and smaller as the speed of the motor increases.

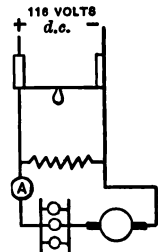

FIG. 221. — Starting of Shunt Motor.

**Counter Electro-motive Force.** — When an armature rotates in a magnetic field, the armature wires cut the field flux and thus generate an electro-motive force. This electro-motive force is termed in a motor a *counter electro-motive force*, because it tends to send a current in the opposite direction from the current, causing it to rotate. The terminal e. m. f. and the counter e. m. f. therefore oppose each other, the difference between the two e. m. f.'s being the e. m. f. that forces the current through the armature circuit. This difference, divided by the resistance of the armature, yields the current that passes through it :

$$I = \frac{E - E'}{R},$$

where  $I$  = armature current,  
 $R$  = armature resistance,  
 $E$  = line e. m. f.,  
 $E'$  = counter e. m. f.

This counter e. m. f. obviously increases with the speed, provided that the field strength remains constant. The counter e. m. f. is probably the most important characteristic of a motor, as it always serves to regulate the amount of

current passing through a motor, reducing this current to a minimum and making variations of current automatic with changes in the load.

**Experiment 92.** Continue turning on lamps as in the previous experiment, allowing the speed of the motor to increase more and more until finally the resistance may be reduced to zero by *short-circuiting* the lamp board. The machine will then be operating as a shunt motor, the armature and the field circuits being in parallel.

As the load of a motor is increased, its speed is lowered; this decreases the counter e. m. f., which in turn allows more current to pass through the armature. As the armature current increases, the *torque* or *twisting force* of the axle increases. This process of adjustment is going on continually in a shunt motor, the input always equaling the mechanical output in horsepower plus the losses in the machine.

**Starting Boxes.** — The function of a starting box is to regulate at starting the input of current into the armature circuit. The starting box for a shunt motor usually has three terminals, although a new form of four-terminal box is being placed on the market by the General Electric Company. The circuits of a starting box may be most readily understood

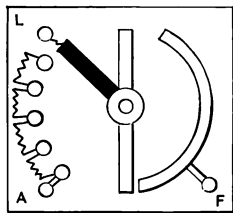

FIG. 222. — Starting Box.

by referring to an old form of starting box, Fig. 222, made by the Crocker Wheeler Company. The starting box has three terminals marked *L*, line, *A*, armature, and *F*, field. The moving arm is connected through a brass strip to the terminal *L*, or line. When the handle is moved to the first position, it makes a contact at one end with another brass strip connected to the terminal *F*, or field. With a continued motion of the arm it continues to make

contact with the field strip and it also makes contact at its other extremity with a series of individual brass contacts which are connected inside of the box to a resistance which terminates at *A*, the armature terminal of the box. By still further continuing the motion of the arm these armature contacts are passed, one at a time, until at the end of the travel the arm makes contact directly upon the armature contact *A*. When the starting box arm is on the first contact, field circuit current only passes through the starting box. When on the first armature resistance, the line current also passes through the armature circuit, being limited in magnitude by the series resistance in the box. At the end of the travel of the starting box arm, the armature resistance has been eliminated, and the armature and field circuit are in shunt with each other, Fig. 223.

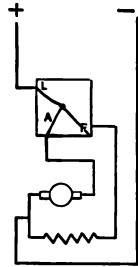

FIG. 223.—Starting Box, Full On.

**Directions for connecting up a Shunt Motor.**—Be sure that oil has been placed in the bearings, that brushes are in contact with the commutator, that the armature can rotate freely, and that there are no loose connections.

**Experiment 93.** Referring to Fig. 223, connect to the service—116-volt direct current—a double pole switch of proper current-carrying capacity. Connect one armature and one field terminal of the motor together, and connect the junction to one of the terminals of the switch, Fig. 223. Connect the other terminal of the switch to the line terminal *L* of the starting box. Connect the armature terminal *A* of the starting box to the free armature terminal of the motor, and also connect the *F*, or field terminal of the starting box, to the free field terminal of the motor. Close the main switch and turn the starting box handle to first contact, thus exciting the field circuit of the motor. Attempt to turn the motor armature while the field circuit is excited, and notice the *stiffness* of the field. Turn the starting box handle back to zero, and notice the arc due to opening the field circuit. Turn the handle on

again and continue the motion "slowly," allowing the speed of the motor to increase gradually until a maximum position is reached.

**Magnet Arm on Starting Box.** — With the old form of starting box just described there was danger of some one's opening the main switch and forgetting to turn back the starting box arm. When it became necessary to start the motor again, the main switch was closed without looking at the starting box, and as a result the fuses were blown, as a short circuit through the armature circuit was formed.



FIG. 224. — Starting box. (Westinghouse.)

To eliminate such occurrences various manufacturing companies, such as the Cutler Hammer Manufacturing Company, developed the form of starting box shown in Figs. 224, 225. In this the forward motion of the arm was resisted by a spring, which would return the arm to zero position if released. When the arm, however, is carried over until it reaches the magnet, Fig.

225, it is held there as long as the magnets are energized. The winding of this magnet is connected internally in the box so that it is in series with the field winding of the motor. If it is desired to stop the motor from operating, the main switch is opened. As the armature of the motor continues to operate, due to its inertia, it generates an electro-motive force which sends a current through the shunt-connected field circuit and helps to maintain the field excitation. When the speed of the motor has decreased sufficiently so as not to endanger the motor should the main switch be thrown, the current in the series magnet becomes weakened, and the spring throws back the starting box arm.

**Caution.**—In order to stop a motor do not “knock” back the starting box arm; instead, open the main switch, since otherwise the e. m. f. of self-induction of the field circuit may puncture the field winding or the insulation of the adjoining wires in the starting box. The writer has had occasion to repair both these types of injury due to this cause. Furthermore, look always at the starting box arm before closing the main switch in order to be sure that the arm has not “stuck,” as occasionally happens. This magnet arm is sometimes called a *low voltage release*, for if the voltage on the system becomes low temporarily, the magnet would not be sufficiently energized, and the arm would fly back.

**Overload Release.**—Some starting boxes are equipped with *overload release*, Fig. 225. This release consists of a coil connected in series with the main line current going to the motor. When the current becomes excessive, a hinged armature is drawn up having two copper strips mounted upon it. When these two contacts, electrically connected, are drawn up, they short-circuit the metallic uprights connected to the terminals of the retaining magnet, and allow the magnet arm to fly back.



FIG. 225.—Cutler Hammer Starting Box.

**Experiment 94.** Make regular set-up with a starting box provided with overload release. Put a brake load upon the motor, and note the

operation of release. Also, trip coil by raising its armature with the finger.

**Note.** The armature of the release may be raised so as to vary its distance from the pole of its solenoid; in other words, it may be "set" for various overloads.

It is quite important not to start a motor too quickly by moving the starting box arm over too fast, as the inrush of current may be so great as to blow out the main fuses.

**Experiment 95.** Connect an ammeter, projecting, in series with a regular shunt motor, and turn on the handle of the starting box at various rates to determine the range of the starting current.

**Changing Direction of Rotation.** — In order to change the direction of rotation of a shunt motor, it is necessary to change the direction of the current, either through the armature or the field circuit.

**Experiment 96.** Make an ordinary set-up of a shunt motor, as indicated in Fig. 226 *a*, and note the direction of rotation.

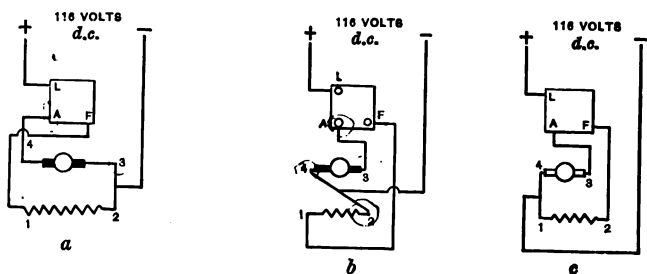

FIG. 226. — Motor Circuits.

**Experiment 97.** Without disturbing the line connections, disconnect the junction of the armature and field circuit at 2-3, Fig. 226 *a*, and disconnect the armature terminal *A* from the starting box. Connect field terminal 2, Fig. 226 *b*, to armature terminal 4, and connect the junction to the service wire. Connect armature terminal 3 to the starting box at *A*. This will reverse the direction of the current through the armature circuit, Fig. 226 *b*, and will change the direction of rotation of

the machine without changing the previous direction of the current through the field circuit.

**Experiment 98.** Connect armature terminal 4 to the field terminal 1 and connect to service, as in Fig. 226 *c*. Connect armature terminal 3 to the starting box and field terminal 2 to starting box. This will maintain direction of current through armature the same as in previous experiment, but will reverse the direction of the current through the field circuit, changing the direction of rotation of the armature, Fig. 226 *c*.

**Experiment 99.** Change over the line terminals at the switch, exchanging the positive for the negative, and note that the remainder of the set-up is undisturbed. Direction of rotation will remain unchanged.

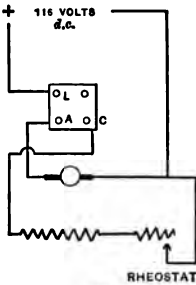

FIG. 227.—Field Circuit.

**Speed Variation.** — A variation of speed in a shunt motor may be obtained by shifting the brushes, by placing a resistance in series with the armature circuit, or by placing a resistance in series with the field circuit, Fig. 227. The method usually employed in practice is placing the resistance in series with the field circuit.

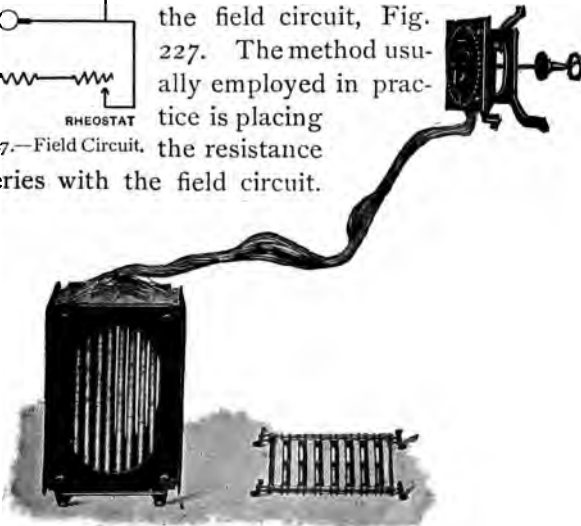

FIG. 228.—Remote Control Resistance.



Figure 228 shows the method of installing large rheostats where the switch is separate from the resistance (G. E. Co.). The value of this resistance should be about equal to that of the field resistance of the motor, so that the field current can be reduced to half value.

**Experiment 100.** Make a set-up, as shown in Fig. 227, placing the field rheostat in series with the field coils of the motor. Vary the resistance, and note the change in speed.

**Note.** Never start up a motor without being sure that the field rheostat handle is at zero or that all of the resistance is out of the circuit, otherwise the motor will accelerate too quickly. With a weakened field there is a lower counter e. m. f. induced in the armature at starting, and consequently there is a greater inrush of current than necessary, causing too rapid an acceleration.

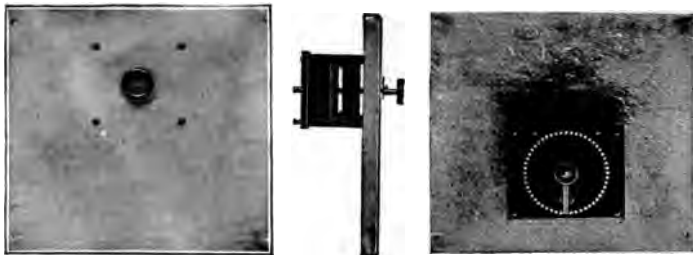

FIG. 229.—Self-contained Rheostat (G. E. Co.).

Take care not to open the field circuit of a motor while operating, as the motor armature may “run away,” for with almost a zero field it would require an infinite speed to generate sufficient counter e. m. f. to limit the armature current. For small size motors, rheostats are usually self-contained, as in Fig. 229.

**How to tell whether Field Resistance is All In or All Out.** — Rheostats when mounted upon a switch board are usually marked “resistance out,” “resistance in,” indicating the direction of motion to produce one condition or the other by arrows, see Fig. 230. The resistance is connected

between two terminals of the metal support as in Fig. 231.

An additional wire or metal strip connects one of the terminals to the moving contact arm. As this arm is moved, it short-circuits part of the resistance of the box.



FIG. 231.—Circuits of Rheostat.

When the arm is to the right, Fig. 231, all of its resistance is in circuit, and when it is to the left, all of the resistance has been eliminated.



FIG. 230.—Dial of Rheostat.

Field rheostats are made in very compact form for small machines by the Cutler Hammer Company, as shown in Fig. 232, the rheostat being filled with porcelain as shown in Fig. 233, in which the resistance is embedded.



FIG. 232.—Field Rheostat.

**Experiment 101.** Take a 500-ohm rheostat, and place it in series with a 16-candle-power lamp and a 120-volt direct current circuit. Vary the rheostat and note its position when resistance is "all in," and when it is "all out." When in doubt, look at the back of the rheostat.



FIG. 233.—Cross Section of Cutler Hammer Rheostat.

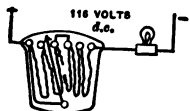

FIG. 234.—Burnt-out Rheostat.

**Experiment 102.** Use a field rheostat which is open circuited, burnt out, as in Fig. 234, and make a set-up similar to that in the previous experiment. Use a short piece of wire termed a jumper and make a contact between the various terminals until the lamp lights, showing that the jumper has

spanned the gap. Solder this jumper to these two contacts, taking care that the movable arm can slide over the soldered connections unobstructed. The rheostat has now been repaired.

**Theory of Speed Variation.** — When the field circuit of a motor has been weakened by the insertion of resistance, the armature counter e. m. f. will be correspondingly decreased. When this happens, according to the law  $I = \frac{E - E'}{r}$ , the armature current will increase as  $E$  and  $r$  are constant. As the current in the armature increases, the torque increases, and this increases the speed. As the speed increases, the counter e. m. f. increases, until, as previously stated, the energy input equals the output plus the losses in the machine.

**Location of Trouble.** — When a motor does not operate, it is not necessarily disabled. It may be improperly set up, there may be terminals loose, brushes may be not in contact with the commutator, or something may be the matter with the starting box. The following procedure is desirable in case the motor will not start:

1. Spin motor armature with hand, and see that the armature is free.
2. See that the brushes are in contact with the commutator and that oil is in the bearings.
3. Go over the machine carefully, and see that all wires in the set-up have been properly connected.
4. Test out the circuit with fingers or with lamp, and see that the power is "on."
5. Put the starting box handle on the first contact, closing the field circuit, and allow it to return to zero. If the switch flashes as it leaves contact, the field circuit is probably satisfactory. If no flash occurs, the field circuit is open; it may be open in the starting box or it may be

open in the motor. Some field terminals are very poorly connected in the machine, and they have a tendency to become loose.

6. If the field circuit is satisfactory, continue the motion of the starting box arm so that contact is made with the armature circuit. If the motor does not start, the armature circuit may be open. If the motor runs "wild" as the starting box handle is turned on and the starting box begins to smoke, it is a pretty sure sign that the field circuit is open.

7. When the machine is operating, if the commutator flashes as it goes around, this may be the result of a high bar, a short-circuited armature coil, or a hard spot in the brushes.

8. If the field coils heat excessively, if the sparking of the brushes becomes severe, or if the armature smokes, there are defects in the machine which must be remedied. The fault may be located in some of the following ways.

**Tests for Grounds.**—A simple test lamp connected up with one terminal to the service and the other terminal connected to the frame of the motor, as in Fig. 235, and an extra test wire extending from the other service terminal which can be connected to various parts of the machine, are all that is

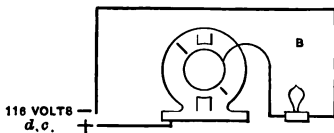

FIG. 235.—Test for Grounded Armature.

necessary for ordinary ground testing. Where it is desired to measure the resistance of the ground, a 150-volt voltmeter substituted for the lamp will yield the correct result.

**Experiment 103.** *Test for grounded armature.* Make the set-up as shown in Fig. 235, raise the brushes so that they will not be in contact with the commutator, and place terminal B on the commutator. If the lamp lights, the armature is grounded. All of the armature wires should then be unsoldered and disconnected from the commutator, and

terminal *B* should be placed in contact with the commutator. If the lamp lights, the commutator is grounded. Place terminal *B* on the armature winding after testing the commutator and make a similar test. When disconnecting the wires from the commutator, they should be tagged so that they can be properly replaced.

**Experiment 104. Grounded Field Coil.**— Disconnect the field terminals from a terminal block and placing terminal *B*, Fig. 236, on the field terminal, note result. The field coils may be easily disconnected from each other, so that a grounded field coil may be readily located.

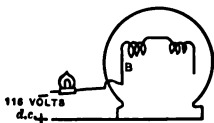

FIG. 236.— Test for Grounded Field Coil.

than a grounded coil. With a four-pole machine, if one of the field coils be short-circuited, the coil may be located with a voltmeter as in Fig. 237. The resistance of the various coils are approximately equal, and consequently the distribution of potential is proportional to the resistance, the short-circuited coil having a low voltage reading.

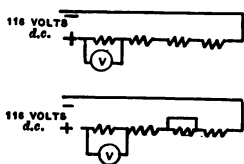

FIG. 237.— Test for Short-circuited Field Coils.

**Experiment 105.** With a four-pole machine connected to a 116-volt direct current source of potential, as Fig. 237, measure with a voltmeter the distribution of potential across each field coil.

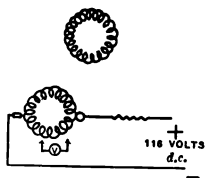

FIG. 238.— Test for Short-circuited Armature Coils.

**Experiment 106.** With same set-up short-circuit one of field coils, Fig. 237, and notice the readjustment of potential. In the first case the volts per coil will be 29 on a 116-volt circuit and in the second case the volts per coil will be 38.6.

**Short-circuited Armature Coil.**— A short-circuited armature coil requires more care in its location than a similar defect in a field coil.

**Experiment 107.** Connect a resistance in series with the brushes of a short-circuited armature and a 120-volt circuit so that about 5 amperes is passing through the circuit. Test with a low scale voltmeter across each pair of adjoining commutator segments, Fig. 238. A low reading of the voltmeter will indicate trouble in the coil. Be sure that the main current is passing through the armature at all times while the test is being made, for if the circuit should be open in two coils, one on each side of the brushes, a low voltage voltmeter would span the gap while testing, and the needle would be badly jammed by having 120 volts across the low voltage, 3 volts, coil.

**Experiment 108.** Prepare an old armature with two open-circuited coils and a short-circuited coil. Make a set-up similar to that in the last experiment, and test with the voltmeter. Use 150-volt scale of the voltmeter so that when the voltmeter spans open circuit and the entire potential is across the voltmeter, the needle will not bank, as it would if low scale were used.

**Resistance of Ground.** — A standard Weston voltmeter with a high resistance of about 15,000 ohms serves as a ready method of testing for grounds. By placing the voltmeter in series with a source of potential and then by testing one terminal of the device, the resistance can be readily calculated as follows:

**Experiment 109.** Take a switchboard which is partially grounded, and make a set-up as in Fig. 239. Connect one terminal of the voltmeter to the positive switch and the other terminal to the metal part of the board. The resistance is then calculated by reading the voltage of the service, the amount of drop in voltage, and using the proportion,

$$e : e' :: R : x,$$

where  $e$  = voltmeter reading when drop in voltage  $e'$  is obtained, and  $R$  = resistance of voltmeter.

$$E = e + e'.$$

The distribution of potential is proportional to the resistance in a series direct current circuit.

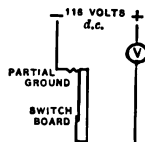

FIG. 239. — Test of Grounded Switchboard.

**Interpole Motors.**—The introduction of interpoles in motors, Fig. 240, has resulted in improving their commutation to a marked extent, so much so that a motor can be

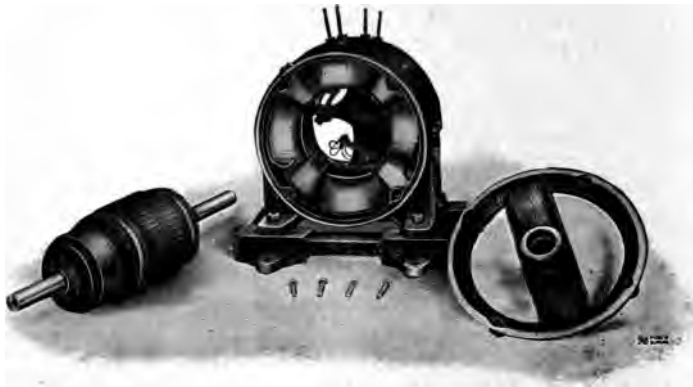

FIG. 240. — Interpole Motor (G. E. Co.).

reversed at full speed. The interpole winding is usually placed in series with the armature and tends to neutralize its self-induction.

#### QUESTIONS

1. Explain how you would tell a shunt motor from other motors if the machine did not have a name plate.
2. What is the function of a starting box and how would you set up a shunt motor with a starting box? Give diagram of connections.
3. How would you change the direction of rotation of a motor?
4. If motor sparks as it rotates, how would you go about locating the trouble, if, after cleaning the brushes, and the commutator, and shifting the rocker arm, it still continued?
5. How would you determine whether field coils were grounded, short-circuited, improperly connected, or burnt out?

6. What do we mean by counter e. m. f., and how does it affect the speed variation of a shunt motor?

7. How would you locate a burnt-out coil in an armature ?

8. Why is the shunt motor essentially a constant speed machine? Give theory of speed variation.

9. If an armature was operating on a 116-volt circuit, the resistance of the armature was .10 ohm, and 10 amperes were passing through the armature, what would be the counter e. m. f. ? *Ans.* 115 volts.

10. What is the cause of the heavy spark on breaking the field circuit of a motor, although the current passing through the field circuit is very small ?

11. In what manner do the interpoles on a motor eliminate sparking ?

12. If 746 watts equal a horsepower, approximately, how many amperes can you figure to the horsepower for a motor on a 116-volt circuit ?

*Ans.* 6.43.



## CHAPTER X

### THE SERIES MOTOR

**Characteristics of the Series Motor.**— In general appearance and construction the direct current series motor is similar to the direct current shunt motor discussed in the last chapter. A series motor possesses an armature, a field circuit, brushes, commutator, and many other characteristic features of the shunt motor.

The counter e. m. f. generated in the armature of a series motor plays the same important part in the operation of the motor as it does in the shunt motor, and the armature also requires some form of starting device. The direction of rotation of the series motor may be changed, as with the shunt motor, by changing the direction of the current through either the armature or the field circuit.

From an operating viewpoint, however, the series motor differs from the shunt motor, being a variable speed machine, whereas the shunt motor is a constant speed machine. The field circuit of a shunt machine has a constant excitation, whereas the excitation of the series motor is variable, all of the current which passes through the field circuit passing through the armature circuit, as in Fig. 241. The following suggestions may be of interest to

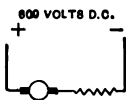

FIG. 241.— Series Motor Circuit.

those who find it necessary to distinguish a series motor from a shunt motor. A series motor, if its direction of rotation is fixed, usually has two terminals on the frame of the machine instead of three or four, as with the shunt machine. This does not apply to railway motors, in which it is necessary to change the direction of rotation.

As the same current which passes through the armature circuit passes through the field circuit also, the field winding as well as the armature winding must have a low resistance in order to keep down the resistance losses. The field windings are therefore wound with copper strip of many times larger cross section than the field winding of a shunt machine.

**Magnetic Circuits of the Series Motor.** — The magnetic circuits of a series motor are similar to those of the shunt motor, and the same tests may be applied to determine whether the field coils are properly connected, and also to locate grounds and open circuits in the windings.

**Resistance of Armature and Field Circuits of the Series Motor.** — As the same current which passes through the armature circuit of a series motor passes through the field circuit, the field coils resistance must be low, as previously stated, in order that the energy lost in overcoming the resistance of the field winding will not be excessive.

**Experiment 110.** — Measure resistance of armature and field circuits of a series machine, taking the precaution to place a series resistance in circuit with the machine, as indicated in Fig. 242. If the current used in this experiment is sufficiently low, the machine will not rotate. If it does tend to rotate, the armature should be blocked, for if voltage readings are taken across the armature circuit while rotating, the voltage value indicated will be a resultant of the counter e. m. f. and the  $IR$  drop. The magnitude of the field resistance will be of the same order as that of the armature resistance, that is, about .5 ohm for small machines and .05 ohm for large motors of 150–200 horsepower as used for railway operation.

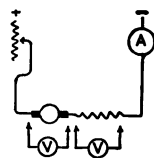

FIG. 242. — Measuring Resistances of Series Motor.

**Starting of a Series Motor.** — Since the counter e. m. f. developed in the armature of the series motor performs the same function as in the shunt motor, and since the

armature and field resistance of the motor are both of small magnitude, a series starting resistance becomes a necessity. This resistance is placed directly in the circuit, and in series with both the armature and the field circuit. It will be remembered that with the shunt machine the resistance was placed simply in the armature circuit. As the speed of a series motor increases, this resistance is gradually eliminated. The counter e. m. f. increases with an increase in speed, and this tends to lower the current input. As the current input decreases, the field strength decreases, and this tends still further to increase the speed. This process of adjustment continues while the machine is in operation, and requires that where the resistance values of the motor are low, the motor's load should be connected to it rigidly. The series motor is used only where it can be directly connected to its load, as in railway operation and in elevator work, in which a large starting torque is desired. The speed of the motor governs its energy input, the energy output plus the losses equalling the energy input. There are in use series motors of small capacity and of large resistance which may be directly connected to a 240-volt service without resistance in the circuit.

When the current increases with decreased speed, the torque, or twisting force, of the armature increases, the motor exerting its greatest tractive force at zero speed. With railway operation this increased tractive effort at low speeds is especially desirable, as it is necessary to overcome the inertia of the train at rest. When the train is operating at maximum speed, the energy consumption is reduced to a minimum. After a time the power is cut off, and the train is allowed to coast, the brakes being finally applied. About 65 % of the energy put into the train while accelerating is taken from the train at braking.

**Speed and Tractive Effort Curves.**—It is customary to show the performance of a series motor by means of a series of curves, all plotted in terms of current input. These curves indicate speed, tractive effort, and efficiency at the various current values. The term *tractive effort*, when applied to a railway motor, means the horizontal pull at the base of the car wheel, Fig. 243. The term *torque* means the moment of pull on the shaft of a motor and is usually expressed in foot-pounds. The pull on a belt passed over a pulley expressed in pounds, multiplied by the radius of the pulley in feet, will give the torque or twisting force of the motor for that particular radius of pulley. With a trolley motor a small gear mounted upon the shaft of the motor meshes into a larger gear on the wheel axle of the car. One side of the motor is upon the car axle, and the other side of the motor faces the other car axle. Upon the latter is mounted the larger gear, suspended by various forms of suspension called bar, nose, or spring suspension, depending upon the manner in which it is accomplished. It may readily be

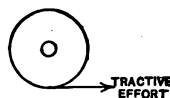

FIG. 243.—Tractive Effort of Series Motor.

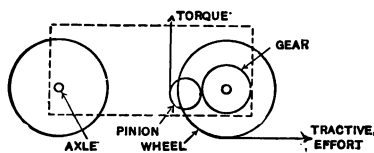

FIG. 244.—Relation of Torque to Tractive Effort of Series Motor.

seen, then, from Fig. 244, that the torque of the motor may be converted into tractive effort, the tractive effort, as previously stated, being the horizontal pull at the base of the car wheel.

In the characteristic curve sheet, Fig. 245, it may be noted that the tractive effort is almost proportional to the current input, except at the lower part of the curve below the knee of the magnetization curve or where the iron is below saturation.

*The tractive effort of a series motor depends solely upon the current input, to which it is directly proportional. It is*

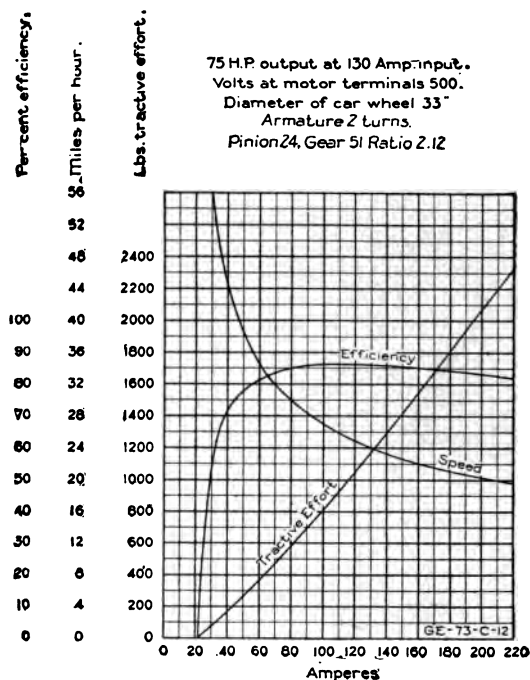

FIG. 245. — Characteristic Curves of Series Motor.

*also independent of the line voltage for the same current input.*

The speed of a series motor is approximately inversely proportional to the square of the current between certain limits. If the current input is at a minimum, the change in speed is very great for a small change in current; but if the current input is near the full load value, a large change in current can occur with a small change in speed.

*The speed of a series motor for a given current input varies with the impressed voltage.*

The e. m. f. current relations in a series motor are expressed by the formula  $I = \frac{E - E'}{r}$ , where  $I$  is the current passing through the armature,  $E$  is the impressed voltage across the armature terminals,  $E'$  is the counter e. m. f., and  $r$  is the resistance of the armature circuit. Characteristic curves, Fig. 245, are always taken for a constant impressed e. m. f., whose value is usually given on the curve sheet.

**Experiment 111.** Place a projecting ammeter in series with a small series motor, and place a brake over the motor pulley, so arranging the brake that its motion may be magnified as in Fig. 246 in order that a large number of people might be able to see such motion as would occur. Take a series of observations of pounds pull for various current values, and plot curve showing current torque relations (lecture experiment).

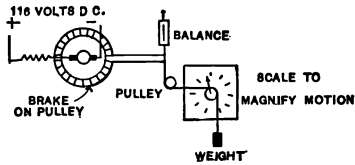

FIG. 246. — Measuring Torque of Series Motor.

**Experiment 112.** With the same motor set-up belt a Weston speed tachometer to the motor pulley and connect electrically the tachometer to a projecting voltmeter, Fig. 247, calibrating the voltmeter to read speed (that is, so many revolutions of the motor, as shown by a speed indicator, would be equivalent to so many volts generated).

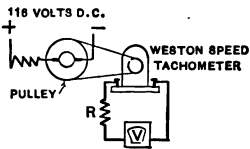

FIG. 247. — Measuring Speed of Series Motor.

Vary the speed by placing a light load upon the motor, and take a series of observations of speed and current input. Arrange a double throw switch, Fig. 248, so that the projecting galvanometer terminals come to the middle terminals, and so that two of the switch terminals are connected to the ammeter shunt, and so that the other two switch terminals are connected to the speed tachometer through a series resistance.

Readings of current may then be taken by throwing the switch in one direction, and readings of speed may be taken by throwing the switch in

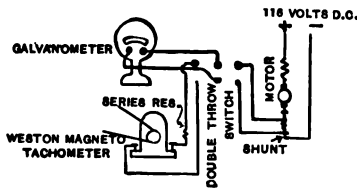

FIG. 248. — Showing Relation of Speed to Current.

the opposite direction. A  $\frac{1}{4}$ -horse-power motor is very satisfactory for this experiment (lecture experiment).

**Changing Direction of Rotation of a Series Motor.** — The same method may be used to change the direction of rotation of a series motor as a shunt motor, namely, changing the direction of the current either through the armature or through the field circuit. In railway motors it is customary to change over the armature terminals.

**Experiment 113.** — Set up a small series motor, Fig. 249, and change the direction of rotation by changing over first the armature and then the field terminals.

**Railway Controllers.** — In starting a series motor an auxiliary series resistance is a necessity. This resistance is gradually eliminated from the circuit as the speed of the motor increases. The device used in railway work to accomplish this function is termed a *controller*. Controllers are so arranged that the direction of motion of the car may be changed also by the manipulation of a handle separate from the main controller handle, or the circuits may be arranged so that when the controller handle is moved in the opposite direction the car's motion is reversed. The latter method is used in the equipments of the Westinghouse Manufacturing Company. Controllers are of two fundamental types, namely, hand control and automatic control. Both types of control require the manipulation of a main controller handle by

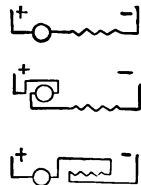

FIG. 249. — Circuits for changing Direction of Rotation of Series Motor.

a motorman. The motion of the main controller handle gradually eliminates the resistance from the circuit. With the automatic control a limit switch, page 29, automatically permits the forward motion of the controller, the limit switch being in series with the main line.

As the current which is interrupted at the various notches in the manipulation of a controller is of large magnitude, both in the hand control and the automatic control, means must be taken to extinguish the arcs formed. This is accomplished by magnetic blow-outs described on page 34. The principal type of controller in use is known as the series multiple control. The purpose of the series multiple control is to provide two or three running positions

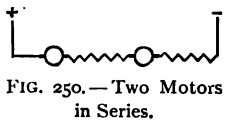

FIG. 250.—Two Motors in Series.

A running position, Fig. 250, is one in which all of the external resistance has been eliminated from the motor circuit, the resistance grids

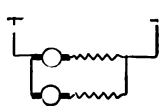

FIG. 251.—Two Motors in Parallel.

not being intended for continuous operation. With a two-motor equipment of series multiple control, as in Figs. 250, 251, there would be two running positions possible. In series position on a 600-volt direct current circuit there would be 300 volts across each

motor, the motor operating at half speed, and at full multiple position, or 600 volts full speed, both motors would be operating in parallel on 600 volts. With a four-motor equipment three running positions may be obtained. In one case the four motors are in series with each

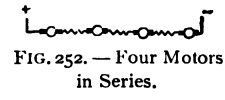

FIG. 252.—Four Motors in Series.

other, Fig. 252, having a potential difference of 150 volts per motor. In the second position the motors are connected in series of two sets in parallel having a potential difference of 300 volts per motor, Fig. 253. In the third running



position the potential difference is 600 volts per motor, Fig. 254. With a four motor equipment such as the four 40-

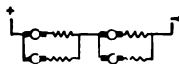

FIG. 253. — Four-motor Equipment.

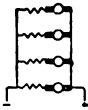

FIG. 254. — Four Motors in Parallel.

horsepower motors used in trolley operation, it is customary to employ the series multiple control having two running positions. During the last few years there has been introduced a modification of the ordinary controllers which employs some of the features of the automatic control. These features consist in the use of a few contactors placed under the car so as to open and close the trolley circuit away from the main controller. The purpose of this is to eliminate the so-called "controller burn-outs." A series of experiments illustrating the action of controller burn-outs are recorded by the writer in the *Engineers' News*. In the old types of controller it was customary in passing from the series to the multiple position to open the controller circuit, thus causing an unwelcome jerk to the passengers in the car. This is now avoided in the automatic control by what is known as the bridge connection, Fig. 255. The principle of the bridge connection is that the two motors are connected in series with each

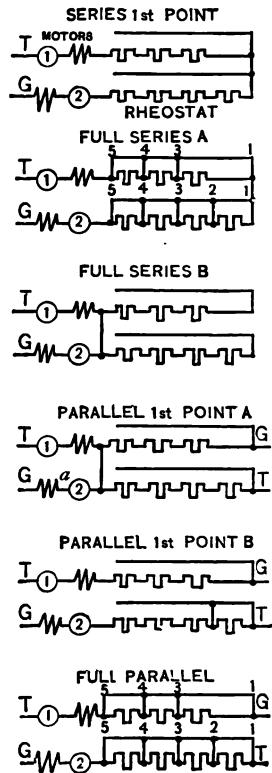

FIG. 255. — Bridge Control.

other, with resistance, and the line voltage. The resistance is gradually eliminated from the circuit by means of contactors until both motors are in series with the 600-volt circuit, Full series B.

The ground switch and positive switch are now connected, the short-circuiting switch is still closed. This places both motors in parallel with each other and the 600-volt circuit and with resistance, the bridge connection still remaining. The switch *a* is then opened, and the series resistance eliminated step by step from both motors until they are both operating in parallel with the 600-volt circuit. A complete description of the various methods of control with detail diagrams may be found at pages 102 to 164 of the author's *Electric Railways*, Vol. I. Space will not permit a fuller description here.

**Emergency Brake of the Series Motor.** — In case the air brakes of a car should fail in their operation, it is well to know how to stop the car by means of the motor. With series motors operating with field circuit excited, if the power be turned off when the car is operating at a fair speed, the reverser on the controller thrown, and in a two-motor equipment the controller handle turned to full multiple position, the motors will become generators operating in parallel, the one generating the higher e. m. f. sending its current through the other motor, causing it to motorize and tend to change the direction of rotation. With a four-motor equipment where only two running positions are in use, the motors being operated in two pairs of two motors which are permanently connected in parallel, it is simply necessary to open the line switch and throw the reverser, the car coming to a stop almost instantaneously.

**Experiment 114.** — Take two series motors mounted upon a stand equipped with type *H* controller and practice the emergency brake. Do

not allow the speed of the motors to become too great lest the armatures may become injured by being raised against the field coils. Place an ammeter in the armature circuit of one of the motors, and notice the large magnitude of the current passing through the motor when the braking effect takes place.

**Testing out Controller.** — In order to minimize the trouble from defective controller wiring or defective insulation of controller, it is well to subject the controller equipment to two tests. One of these tests should be made at fairly frequent intervals; this is the regular voltmeter test (page 128) which measures the insulating value in ohms of the resistance. The second test is the use of at least 2200 volts, and preferably 6000 volts, alternating e. m. f. from a transformer, one terminal being grounded, and the other terminal placed on the line controller leads and ground connection of the motor removed. This high voltage will break down defective insulation. In the operation of electric trains or trolley cars it is well to guard not only against controller burn-outs, but also against delays resulting from breakdowns.

**Structural Features of the Series Motor.** — Owing to the heavy service imposed upon series motors, particularly in railway operation, it is necessary to construct them somewhat differently from ordinary series motors. They have one advantage over the stationary motor when mounted on a car in that they will carry about 25 % more load owing to their better ventilation. Railway motors must be compact, as the space in which they are installed is quite limited. Their frames must be arranged either upon hinges to allow the armatures to be taken out or, as with the box frame type of motor, with the end castings that hold the armature in position so placed that the armatures may be slid out, these obviating the necessity of using a pit. The motors must be inclosed so far as possible, since

frequently they have to run through water which comes part way over the field frame. The armature windings must be cross connected so that with a four-pole machine only two sets of brushes will be necessary, and these brushes may be reached through the trap in the car floor.

In all cases where it is necessary to go under a car which is either in the shops or on the main line, care should be taken to display proper signals to indicate that a man is beneath the car, and when the work is being done in the shops, an "out of service" sign should be used in addition.

#### QUESTIONS

1. How does a series motor differ in structural features from a shunt motor ?
2. What classes of service is the series motor especially adapted for and why ?
3. Explain how the counter e. m. f. affects the operation of a series motor.
4. What is meant by the emergency brake when applied to a series railway motor equipment ?
5. How would you determine the counter e. m. f. of a series motor when operating at a certain current input under a given potential ?
6. Draw a diagram showing how a series motor may be set up with starting resistance and also show how its direction of rotation may be changed.
7. What do the characteristic curves of a series motor show, and what relation exists between torque and current input ?
8. What method is used in a railway equipment to produce a constant rate of acceleration until almost up to speed ?
9. Why is it necessary to have a series motor rigidly connected to its load ?
10. About what relation exists between the armature and the field resistance of a series motor ?

## CHAPTER XI

### THE ARC LIGHT

**The Carbon Arc.**—The electric arc was first produced by Sir Humphry Davy in 1805. The arc was formed between two wood charcoal pencils from a battery of 2000 cells. The name *arc* has been given to the bridge of conducting vapors because of its arched shape. To form an arc between two electric light carbons it is first necessary to bring the carbons into contact and then to separate them a small distance, about  $\frac{1}{8}$  inch. In the modern arc lamp means are provided to bring the carbons into contact, to separate them, and to feed the carbons together as they are consumed. These arc lamp mechanisms are automatic in their action. With the carbon arc almost all of the illumination

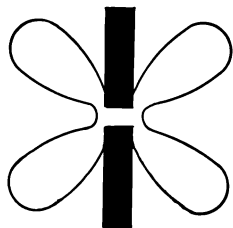

FIG. 256. — Alternating Current Arc.

is given off from the tips of the carbons, which become molten at a temperature of about  $4500^{\circ}$  C. With the direct current carbon arc lamp, almost all of the illumination is given off from the upper positive carbon, the luminous part being termed the crater. With the direct current arc lamp, the positive carbon is consumed about twice as fast as the negative carbon. With an alternating current arc, Fig. 256, both carbons are equally luminous, and both are consumed at about the same rate.

Practically no illumination is given off by the arc flame in a carbon arc. The distribution of candle power from an alternating current arc is about as shown in Fig. 256.

**Experiment 115.** Form an arc between two electric light carbons having a resistance in series with the carbons and a 116-volt direct current source of supply. Preferably use an automatic arc lamp in a projecting lantern. Project this arc on the screen in any one of a number of ways. Remove both condensers from the projecting lantern and bring the objective lens near the arc, focusing the arc upon the screen. Or use the condensers alone, inserting a card in which is a narrow slit  $\frac{1}{8}$  inch by 1 inch in the slide carrier; then remove the objective lens, drawing the arc lamp back until a focus is formed. It may be necessary to remove one of the condensers. If this arc on the screen is observed in a darkened room, it will be noticed that the arc flame is practically non-luminous, having a central zone of bluish vapor, carbon monoxide. Outside of this zone there is a slight yellowish flame showing combustion taking place, the carbon monoxide burning in the air forming carbon dioxide. If an automatic lamp is used, the operation of striking the arc and feeding the carbons may be readily seen. As the carbons burn away, just before feeding the arc flame may travel around one of the carbons seeking the point of least resistance. Small bubbles of impurities will be noticed upon the positive carbon which will quickly dart across the arc flame.

**Experiment 116.** Form an arc between a pair of carbons having an adjustable resistance in series with the carbon and a 116-volt direct current source of supply. Place an ammeter in series with the carbons and shunt the carbons with a voltmeter. Both ammeter and voltmeter may be projecting instruments. When the lamp is operating, notice the voltage and current relations. The arc voltage should be about 40 volts if both cored carbons are used. Vary the distance between carbons and notice the change in potential values. At about 12 amperes,  $\frac{1}{8}$  inch arc, the potential will be 40 volts and the resistance of the arc 3.33 ohms.

**Experiment 117.** When the arc is projected on the screen, interpose in its path red, yellow, and blue glasses, and notice in each case that the arc assumes that particular color. This experiment shows that the temperature of the crater of the arc is so high that it emits light of all visible wave lengths.

**Experiment 118.** Make a set-up in a regular projecting lantern, placing a card with a small slit in it in the slide carrier, Fig. 257.

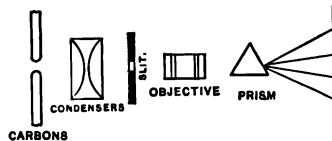

FIG. 257.— Method of obtaining Spectrum.

Interpose in the path of the rays

as they leave the objective lens a carbon bisulphide prism, and notice the *pure spectrum* on the screen. Compare this with a daylight spectrum.

**Physics of the Carbon Arc.** — When the temperature of a body is raised, the body emits heat waves whose wave lengths are comparatively long compared with the wave lengths of light. As the temperature of the body is raised higher, it continues to emit these invisible radiations of heat and light, which are termed the infra part of the spectrum. The radiations vary approximately as the fourth power of the temperature. When the temperature of the body is about  $1000^{\circ}$  C. the body emits the first visible light rays of a dull red color. Scientists have shown that the red rays are not really the first light-giving or visible rays which actually appear, but that they are located in the yellowish green portion of the spectrum, the spectrum spreading out in both directions as the temperature is raised. The effect on the eye, however, is such that the impression of red is first received, the intensity of the other rays being too slight to affect the vision. After the red appears, the body whose temperature is being raised seems to be getting whiter and whiter. This is due to the fact that other wave lengths of light are appearing and interference is taking place, the colors which combine producing white light. As the temperature of the light source is raised, the efficiency of the illuminant is increased. This is probably due to the fact that more of the invisible radiations become visible at the higher temperature, the intrinsic brightness, or *candle power per square inch of radiating surface*, increasing. The temperature of the carbon arc has been given as approximately  $4500^{\circ}$  C. Although operating at this high temperature, the ordinary carbon arc has a very low light-giving efficiency — approximately .85% for an open arc. It is claimed by mathemati-

cians that by operating at a temperature of  $7000^{\circ}$  C. an efficiency of 50% could be attained. The efficiency of a light source may be determined from two factors, — the mechanical equivalent of light (.02 watts per candle power), and the wattage consumption of the illuminant under consideration. The mechanical equivalent of light is the wattage which would be consumed by an illuminant having an efficiency of 100%.

The intrinsic brightness of some of our modern illuminants is given in the accompanying table: \*

	INTRINSIC BRIGHTNESS
	C. p. per sq. in.
Sun in Zenith . . . . .	600,000
Electric Arc . . . . .	10,000 — 100,000
Calcium Light . . . . .	5,000
Nernst Glower . . . . .	1,000
Carbon Incandescent . . . . .	480
Gem Metalized . . . . .	625
Tantalum . . . . .	750
Tungsten . . . . .	1,000

**Experiment 119.** Take a small iron wire, No. 36, a few feet in length, and send through it a current of electricity of small magnitude, placing an adjustable resistance in series with the wire. Over the wire place a thermo element, as in Fig. 258, or, preferably, twist the wire several times around the element so that the rest of the wire will not get red hot and thus permit the element to conduct the heat away too rapidly. A copper-nickel thermo couple arranged with two junctions, one of which is placed in water, the other over the wire, leaving two free copper terminals to be connected to the galvanometer, affords a satisfactory arrangement. The fact that the two copper terminals are connected to the galvanometer eliminates temperature effects which would occur if only one junction

\* — From J. T. Wilse, in the Bulletin, for January, 1909, Brooklyn Section N. E. L. A.

— From the Electrical Solicitor's Handbook, page 84, N. E. L. A.



were used, especially where the galvanometer is placed before the projecting lantern. The thermo element connected in the manner described will indicate the difference

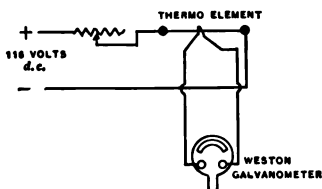

FIG. 258.—Temperature shown with Thermo Element.

in temperature between the water and the wire. The Weston projecting galvanometer described in the appendix, used frequently, will yield .085 scale deflection for  $1^{\circ}$  C. difference in temperature, the resistance of the couple complete being 1.17 ohms at  $25^{\circ}$  C. An ordinary galvanometer may be used by placing

about 5000 ohms in series with it, and projecting an illuminated slit on the mirror, which will reflect the light spot on the screen. Send a current of electricity through the wire, and notice the gradual rise of temperature with the increase in luminosity. The wire will become a dull red at about  $1000^{\circ}$  C. Blow on the wire while it is a dull red, and notice how quickly it loses its luminosity due to the conducting air currents.

**Experiment 120.** To show the illuminating power of some metals at lower temperature than the arc, introduce into a Bunsen flame salts of various substances, such as calcium, lithium, and strontium.

**Experiment 121.** Over a Bunsen flame slowly drop a few iron filings and notice the brilliant shower of white sparks that result and that remind one of fireworks. This experiment shows that when the combustion of iron takes place, a pure white light, comparable with daylight, is produced. This principle is used in the magnetite arc lamp to be described later.

**Experiment 122.** Blow through a small glass tube some lycopodium powder into a Bunsen flame, and note the brilliant illumination that will be produced.

**Experiment 123.** Interpose sheets of iron, zinc, copper, etc., between the carbons of an arc lamp, and notice the additional illumination as combustion occurs. This is the principle of the flaming arc.

So far, the infra rays and the rays of the visible spectrum have been mentioned. Beyond the visible spectrum of red, orange, yellow, green, blue, indigo, and violet lie waves of light of still shorter wave length, termed the ultra

rays. These rays excite fluorescence and penetrate animal tissue as does the slightly different X-ray.

**Efficiency of Light-giving Bodies.** — It has been shown that as the temperature of a body is raised, its efficiency as a light producer increases. If, however, we can use substances, such as calcium, which have a lower fusing point than carbon, an arc may be produced possessing a still higher efficiency. This is the principle of the flaming arc, the point being illustrated in Experiment 120. With the magnetite arc developed by Professor Chas. P. Steinmetz, this feature is more largely utilized, for here is employed oxide of iron,  $\text{Fe}_3\text{O}_4$ , a substance which has a much lower melting point than carbon, and which yields illumination over the whole spectrum, thus producing the most efficient arc light we have. The flaming arc and the magnetite arc will be described in detail later.

One of the most efficient of all illuminants to-day is the Cooper-Hewitt Tube, described on page 216. With this the light produced is not a function of the temperature, the illumination being probably set up by rapid oscillations or vibrations of the molecules of the gas. Heating the tube will not increase the efficiency of the light-giving source. The transformation of energy seems to be more direct, producing an efficiency of about .5 watts per candle power. This lamp is an American product, the result of the investigations of Peter Cooper Hewitt. In the development of the Nernst lamp, the osmium lamp, the tantalum lamp, and the tungsten lamp, efforts have been made to increase the efficiency by operating at higher temperature. The Geissler tubes used for many years experimentally in physics have very high efficiencies as light producers.

**The Ultra Rays.** — For investigating ultra rays an induction coil discharging between two iron electrodes, connected

to its secondary winding and shunted with a series parallel arrangement of condensers as in Fig. 259, serves as an excellent producer of ultra rays. Such an induction coil can be operated from a Wehnelt interrupter (see page 117) and from a direct current source of supply.

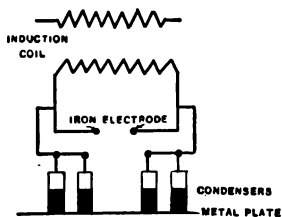

FIG. 259. — Iron Arc.

**Experiment 124.** Operating such an induction coil, hold near it a crystal of willemite, and notice that the willemite will fluoresce beautifully. Cover the willemite

with a sheet of glass, and notice that the glass, opaque to the ultra rays, *insulates* them and that the willemite will not fluoresce. Interpose a sheet of quartz, and notice that the rays penetrate the quartz, causing the willemite to fluoresce. The mercury vapor lamp is a great producer of ultra rays, and so is the sun, but with the mercury tube the glass retaining shell tends to insulate the passage of these rays. Mercury vapor tubes made from quartz are used abroad to sterilize water, the action of the ultra rays being destructive to animal tissue. Place near the discharge points of the induction coil a small glass bottle containing calcium sulphide, phosphorescent. Allow the rays to impinge upon the sulphide and then expose the tube to darkness. The bottle will phosphoresce.

**Experiment 125.** Draw a large sign, such as EDISON, Fig. 260, on a chart and paint it with calcium sulphide, phosphorescent. Expose it to a Cooper-Hewitt tube and then expose it to darkness, and notice that the sign will phosphoresce.

**EDISON**

FIG. 260. — Sign.

**Arc Lamp Circuits.** — In order to maintain a direct current open arc a potential of 40 volts is required across the arc terminals. The resistance of the arc varies with its length and cross section, the resistance of the carbons being quite small. In order to operate an arc it is necessary first to bring the carbons into contact and then to separate them. When the carbons are first in contact, the combined resistance of

carbons and contact is small, as no arc exists; it is so low, in fact, that if the carbons were placed across a potential of 40 volts a large current would pass. To regulate the starting current and also to help smooth out irregularities as the arc operates, a series resistance is inserted in the arc circuit. This resistance, Fig. 261, limits the starting current, and also consumes the excess potential when the arc is in operation. Assume an arc operating on a 117-volt circuit, the arc consuming 40 volts, and the series resistance consuming 77 volts. When the current passing through the arc would tend to fall as the arc resistance increases, due to the carbons burning away, the potential across the series resistance will decrease below 77 volts, and the arc voltage will increase above 40 volts. This series resistance is termed a *balance coil*, and it is a necessity in the arc circuit in order to obtain efficient operation.



FIG. 261.—  
Simple Arc  
Circuit.

Various forms of mechanisms have been developed from time to time to feed together the carbons of an electric arc and to separate them when they are in contact. An extensive

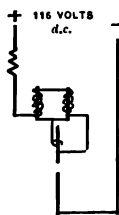

FIG. 262.—  
G. E. Arc  
Mechanism.

description of the more important of these mechanisms may be found in a small volume entitled *Electric Arc Lamps*, by Zeidler and Lustgarten. As most of the recent developments in arc lamps have been foreign, this manual, which provides a résumé of foreign practice, will be found helpful. The simplest mechanism, however, in extensive use in this country for both direct and alternating current arcs is shown in Fig. 262. It consists of a circuit composed of a series resistance, a pair of magnets, and the carbons. These magnets draw up a plunger carry-

ing a simple clutch. When no current is passing through the lamp the clutch falls, allowing the carbons to pass through it as the clutch strikes a support, its circular opening becoming horizontal. This permits the upper carbon to fall and strike the lower carbon. When the carbons are in contact and the circuit is closed, the series magnets draw up the clutch separating the carbons and causing the arc to be formed. As the carbons burn away, the current passing through the arc decreases, the strength of the series magnets decreases, and the armatures of the magnets fall slowly. When they have fallen a certain amount, the clutch supported by the armature strikes a support, causing the carbons to feed. In order that the readjustment of the carbons may not be too rapid, a dashpot is connected with the mechanism. This dashpot has a graphite plunger closely fitted to a cylinder. The dashpot is provided with a needle valve, so that the carbons may be fed together quickly but may be separated slowly. An interesting device was used for many years in a number of arc lamps, notably the Continental Lamp employed by the Boston Edison Company. This device consisted of a bundle of soft iron wires placed in the top of the lamp, a few turns of wire in series with the lamp being passed around them. This device was in reality a choke coil and tended to resist the heavy starting current, the choke coil being effective when the current was rising from zero to its maximum value or when the current changed during operation. The device smoothed out many of the irregularities incident to operation, although it was rather heavy and cumbersome.

**Experiment 126.** Place an ammeter in series with a direct current arc, and notice the starting current; notice also the variation of current during operation. Measure resistance of carbons and series resistance with a voltmeter when the arc is in circuit and calculate starting current on the assumption that no series resistance was present.

**Alternating Current Arc Circuit.**—The alternating current arc mechanism is quite similar to the direct current mechanism, except that the armatures of the solenoid are supported by heavier springs on account of the vibration of an alternating current arc mechanism (G. E. Co.), and that, further, a reactance coil is substituted for the series resistance. This form of device is known as a series mechanism; but there are two other types in use known as shunt and differential mechanism, each of which may be used on both direct and alternating current arc lamps. The shunt mechanism has a high resistance coil shunted across the arc terminal actuating the feeding mechanisms when the potential across the arc terminals rises beyond a predetermined point. A series resistance is also used with this mechanism. With the differential mechanism two coils work in opposition to each other, a shunt and series magnet. Diagrams of the circuits of any of the various arc mechanisms may be readily obtained from the various manufacturing companies.

**Inclosed Arcs.**—Owing to the fact that the carbons of an open arc have to be removed and new ones inserted after burning about ten hours, means were taken in the development of the inclosed arc to extend the life of the carbons. By inclosing the carbons in a small globe having a slight inlet for air, the arc was operated under a partial vacuum; thus the combustion and the current passing through the arc were reduced, and the pressure across the arc terminals was increased from 40 volts to 80 volts. It is very important to regulate carefully the exact amount of air which is allowed to enter the inclosing globe. If too much air enters the globe, the combustion of the carbons becomes too rapid, whereas, if the air supply is too small, not sufficient air will enter to consume the free carbon dust

which comes off from the arc, and it will deposit in a fine powder over the surface of the retaining globe. This adjustment is arranged very ingeniously in the G. E. Co.'s inclosed arcs by a spiral path which the air has to take through the cap of the globe before it enters the globe proper. Inclosed arcs are used extensively for street lighting and for interior lighting, but they are being rapidly superseded in all classes of work by the more efficient tungsten lamp.

**Recent Development in Arc Lamps.** — In addition to the flaming arc and the magnetite arc, previously referred to, several minor developments in arc lamps may be mentioned. Although a few improvements have been made in this country, most have been made abroad. The Daylight lamp is a semi-inclosed arc which uses small carbons, 6 mm. diameter, and burns at 5 amperes at 80 volts, operating semi-inclosed. It contains no inner globe, but the outer globe is of a mushroom shape fitted with a ground edge which is held against a flat metal surface by a spring. The small carbons prevent the wandering of the arc, and the shape of the opal globe assists diffusion. The life of a trim is about 30 hours, the remains of the top carbon being used for the bottom trim. In the Daylight lamp, as the air becomes heated, it is driven out of the inclosing globe.



FIG. 263. — Both Carbons Down-feed.

Sometimes these globes crack from sudden pressure. An improvement with the flaming arc has been to provide a cup-shaped inclosing device of fired clay in which the carbons form their arc. This tends to increase the life of the carbons. Both carbons also feed downward, as in Fig. 263, the arc being formed across their tips, producing a distribution which is superior to the ordinary vertical arc where the positive

carbon is above and the negative carbon is below, casting a heavy shadow under the lamp.

**Factors to be considered in selecting an Illuminant.** — At present there is a tendency in selecting an illuminant to be governed entirely by its efficiency. Other factors, such as first cost, color of illumination, distribution, maintenance, and intrinsic brightness of illuminant should be considered. The Cooper-Hewitt tube, for instance, is one of the most efficient of illuminants expressed in watts per candle power, it has a uniform distribution, great detail-revealing powers, and a life practically infinite, but it is limited in its application by its color. This characteristic, however, is being overcome by operating the lamp in the same inclosing outer globe with a tungsten lamp, thus producing a combined efficiency not quite so high as before, but yielding a light better adapted for general illumination. Owing to the absence of red rays, or that part of the spectrum where the radiant heat rays are present, the light is what may be termed a *cold* light, and is, therefore, very restful for the eyes to work under. The high efficiency of the light is probably caused by the fact that its illumination seems to be concentrated around the yellowish green part of the spectrum, or at that point where the luminosity is the greatest. This light also has a low intrinsic brightness compared with other illuminants. In the tungsten incandescent lamp the efficiency and life are much greater than the carbon lamp, the light is much whiter, as the lamp operates at a higher temperature than the carbon incandescent lamp, but the cost is greater and the filament more fragile. In the Moore tube the distribution is as nearly like daylight as can be produced, especially when the tube is filled with carbon dioxide. The color resembles daylight, and the intrinsic brightness of the tube is about the lowest of any known bare illuminant. The



efficiency of this apparatus, however, is not quite so high as that of the Cooper-Hewitt tube. As regards the distribution of arc lamps, the alternating current arc has the power of reaching out over a greater distance with its light than a direct current arc, and it requires a smaller number of arcs to cover the same territory, owing to the fact that both carbons are luminous. But under some conditions the operation of such a system may not be so efficient as the



FIG. 264.—Holophane Reflector.

direct current system. The use of a Holophane reflector, Fig. 264, with a tungsten lamp with a frosted tip forms one of the most beautiful and efficient illuminants we have. The intrinsic brightness of the combined fixture is low, the efficiency is high, and the distribution may be made almost anything desired according to the shape of the reflector. Care must be taken in the use of illuminants not to have the bare lamps directly in the field of vision, as their high intrinsic brightness tends to injure the eye, owing to the limits of range of contraction of the pupil, and also to interfere with one's ability to read; thus, a 16-candle-power lamp in the field of vision decreased one's ability to read by about 30%. With the Nernst lamp the distribution of the light is quite uniform, the gradual illumination of the lamp is pleasing, its intrinsic brightness is fairly low when equipped with a frosted diffusing globe, and its efficiency about equals that of the tantalum lamp.

**The Flaming Arc.**—The flaming arc consists of carbons

with their cores impregnated with calcium and strontium, having lower points of combustion than the carbon sheel. These substances upon combustion have a high illuminating value, the consumption of the arcs being .3 watts per candle. Owing to the fact that the illumination is given off largely by the arc flame, any irregularities in the operation of the arc cause flickering. The lamps are useful for street illumination where a large volume of light flux is required.

**Experiment 127.** Throw on the screen by means of a projecting lantern (see page 187) a flaming arc. Notice the continuous shifting of the flame, and notice the illumination of the flame. Introduce carbons impregnated with various substances giving a yellow arc, a white arc, and a golden arc.

**Experiment 128.** Throw the spectrum of this arc on the screen by arranging the lantern for ordinary projection, inserting a small slit in the slide carrier, and placing a carbon bisulphide prism before the projecting lens. Notice the broken spectrum lines, and the predominance of green and yellow bands. The green band is a characteristic of most metals.

**Experiment 129.** When using a carbon arc and a prism, it is interesting to show that the ordinary green, blue, and yellow glass employed commercially is not monochromatic. Place these glasses, one at a time, before the prism, and notice that other colors pass besides the color indicated visually. A green glass will pass yellow and blue rays and sometimes a little red. The red glass is fairly monochromatic, however.

**The Magnetite Arc.**—The magnetite arc was developed by Charles P. Steinmetz of the General Electric Company. The purpose of using magnetite, one of the oxides of iron, was to have a metal, which, when consumed, would give a pure white light. The spectrum of iron, as may be readily observed, is almost pure. In the magnetite lamp the positive electrode is made of a bar of copper in the form of a button, and the negative electrode is made of an iron tube filled

with magnetite. The oxide of iron to be used must be such that it will not disintegrate at the ordinary temperatures. With the carbon arc the illumination is given off by the carbon tips heated to incandescence, whereas with the magnetite arc the illumination is given off directly by the flame of the lamp. It may be noted, therefore, that with the magnetite arc, the distribution of light will be more uniform, and there will be fewer shadows, than with the carbon arc. One difficulty, however, results from the flame illumination, for owing to the flickering of the arc the illumination is somewhat unsteady. Because of the consumption of the iron electrode by the arc, fumes are generated that result in a heavy brick-red deposit. This deposit is being minimized in the modern lamps by special draft tubes.

#### QUESTIONS

1. Explain in detail the operation of an arc light, drawing a diagram of circuits, lamp employing ordinary carbon electrodes, series mechanism for multiple circuit.
2. Explain the difference between an ordinary carbon arc, a flaming arc, and a magnetic arc.
3. Give the color values, distribution of light, and watts per candle power of open carbon arc, flaming arc, and magnetite arc.
4. How do the temperature values of the carbon arc, the flaming arc, and the magnetite arc compare?
5. What is the function of the series resistance in arc lamps? Why would it not be better to eliminate this series resistance from the circuit?
6. Give an experiment to show that the arc flame is a conducting medium.
7. What is a cored carbon? How will it help to steady the arc?
8. What is the difference between a differential and a shunt mechanism?

**9.** Mention a few of the modern German improvements in arc lamp manufacture.

**10.** In using an alternating current arc, why is it desirable to use a reflector? How do the luminosity, rate of feed, etc., of direct current and alternating current arcs compare?

**11.** Why is an open carbon arc more efficient in watts per candle power than a carbon incandescent lamp?

## CHAPTER XII

### INCANDESCENT ILLUMINANTS

**The Carbon Incandescent Lamp.**—To Thomas A. Edison is undoubtedly due the credit of inventing and placing in

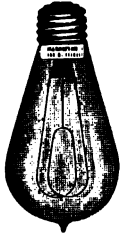

FIG. 265.  
Carbon In-  
candescent  
Lamp.

practice in the United States the first successful commercial incandescent lamp. The Edison lamp was patented in 1878. Other men—J. W. Starr of Cincinnati, in 1845, and J. W. Swan of England, in 1878—had invented incandescent lamps before Edison's patent was issued, but Edison realized that in order to make a success of the incandescent lamp it was necessary to perfect generating and distributing systems as well. Accordingly, he developed the Edison Generator, the Edison Three-wire

System of Distribution, the Edison Underground Tube System of Distribution, and many other elements of the first lighting systems with which we are all acquainted. In the early days of the Edison lamp, men were sent all over the world in search of a suitable material for a filament. A special kind of bamboo was finally selected. The principle of the incandescent lamp as developed by Edison was to inclose a carbonized filament in a vacuum tube and to extract all of the air so that combustion of the filament could not take place when the filament had been rendered incandescent by the passage of an electric current. In the early experiments with the bamboo filament, the lamps had

an efficiency of about 5.8 watts per candle power. Later, when the lamps were finally issued for commercial use, this was reduced to 4.6 watts per candle power.

**Experiment 130.** Partially submerge in water an incandescent lamp in a vertical position, butt end up and tip end down. With a pair of pliers break the tip of the lamp off under water, and notice the rush of water up into the lamp due to atmospheric pressure outside and the presence of a vacuum inside.

Edison's early filament of carbonized bamboo has been superseded, as the early filaments were not uniform. The modern filaments, Fig. 269, are uniform, cheaper, have a longer life, and are more economical in every way. In making the modern filament absorbent cotton is dissolved in chloride of zinc and hydrochloric acid, and stirred until it forms a gelatinous mass like heavy molasses. This material is placed in glass bottles, as in Fig. 266, with a small opening in the bottom which empties into a vessel containing an upright cylinder and alcohol. A slight air pressure is applied to the top bottle, squirting the gelatinous mass through the opening into the lower vessel in a hairlike thread resembling fine spaghetti. Care must be taken throughout the process to allow for shrinkage and to keep the shrinkage uniform. The lower bottle turns as the process continues, the raw filament winding itself upon the upright support. The process is called *squirting*. Later this drum is removed and in the drying room the filament is washed and wound upon a drum (four feet in diameter), Fig. 267, and allowed to dry. A knife blade is then passed along parallel to the axis of the drum, cutting the filaments in lengths of about 14 feet. These filaments are sorted roughly for size; they have the shape of coils about 6 inches in diameter and are placed in drying closets. When dry they are placed upon frames to give the desired

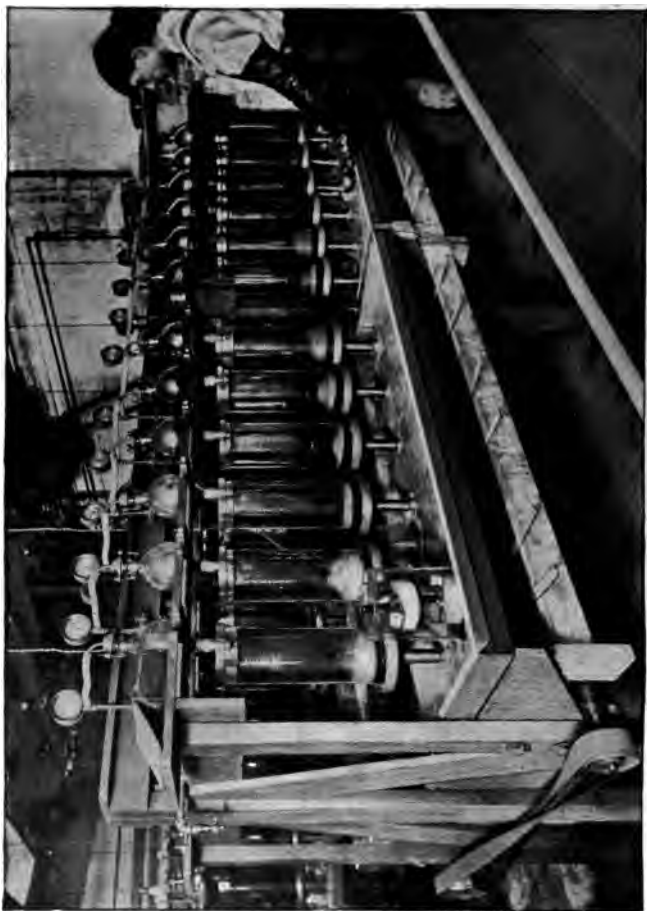

FIG. 266. — Squirting Filaments (Westinghouse Lamp Works).



FIG. 267. — Drying Filaments (Westinghouse Lamp Works).



shape — oval coil, double coil, spiral, or hairpin — and are placed in drying ovens, where they are left for two hours, the temperature being  $450^{\circ}$  F. They are then taken out and cut into separate filaments. In bunches of fifty these separate filaments are dipped in paraffine, making one large filament  $\frac{1}{8}$  inch by  $\frac{5}{16}$  inch in diameter.

They are now ready to be *carbonized*. This process takes about 8 days. The filaments are packed in iron boxes, surrounded with peat, and placed in air-tight furnaces, the temperature being raised to  $1800^{\circ}$ . After a week the furnaces are allowed to cool, and their contents are placed in air-tight graphite crucibles and cemented. The crucibles are next placed in another furnace at  $3200^{\circ}$  F. for two hours. A metallized filament is allowed to remain in the furnace an additional hour. The filaments are then allowed to cool gradually. An extra coating of carbon is next deposited upon the filament to make it of uniform resistance. This is termed *treating*. In treating the filament each operator has four bottles, a relay, and an ammeter. These bottles have their tops flush with the table and are three inches in diameter; each has a two-inch mouth fitted with a soft rubber bushing to make it air-tight when the cap is closed. The filament is supported in the cap with two insulated clamps to which leads are connected, the leads coming out through the cap terminals in two small clips. These clips make contact with two similar clips on the table when the cap is placed in position on the bottle. The operator inserts a filament in the clamps, and places the cap in position, causing the filament to extend down into the bottle. A small port is then opened in the bottom of the bottle, and the air is exhausted to nearly a perfect vacuum —  $\frac{1}{10}$  of 1%. The port is then closed, and another port is opened, admitting gasoline

vapor. As soon as the bottle is filled, the port is closed by a cam which also sends current through the filament. A voltage about 75 % above that upon which the filament is intended to operate is used. When the current passes through the filament, it decomposes the gasoline, depositing carbon on the filament.

The deposit makes a uniform filament, for if one part of the filament is of smaller cross section than another, its resistance is greater and it reaches a higher temperature than the other parts, decomposing more of the vapor and depositing more carbon at that particular point. When the resistance of the filament reaches a predetermined value, the relay automatically cuts off the current. The exhaust port is then opened, allowing the burned gases to escape, destroying the vacuum, so that the cap may be easily removed. The whole process of treating a filament takes about 15 seconds. As the operator has the four bottles working at different stages of the process, the output is rapid.

The glass bulbs as they come from the manufacturer have a round face to which is attached a short neck in the factory, forming what is termed a tabulated bulb, Fig. 268. They also have a mouth about 3 inches long, as in Fig. 268. The carbon filament is cemented at its ends to two small pieces of platinum, which have been previously



FIG. 268. — Bulb with Tip Added.

sealed in a glass stem, Fig. 269. To the other end of the platinum wires are soldered two copper leading-in wires. The platinum wires are necessary where the wires pass through the glass, as platinum has the same coefficient of expansion as the glass, and the glass accordingly will not break. The glass butt is then sealed in the end of the bulb, both being sealed together by heating their point of contact, Fig. 270. The filament is then connected through the leading-in wires to a source of current supply, and the end of the stem of the glass bulb is connected to an air pump, Fig. 270, and a partial vacuum is produced. The operator is able to tell from the color of the luminous conducting gas in the lamp when the vacuum is nearly perfect. When this point is reached, a small amount of red phosphorus previously inserted in the stem of the tube is heated, forming a gas which fills the space of the rarefied air in the bulb. The stem is then sealed off, forming the well-known tip on the lamp. The lamp is then subjected to a series of tests; its vacuum is tested by an induction coil, its filament is tested for bright spots, and the voltage for which the lamp will give the designed candle power is determined on a photometer. This voltage is then indicated on the label of the lamp.

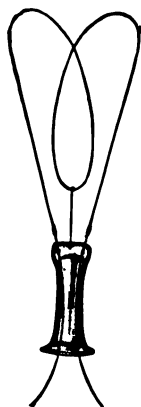

FIG. 269. — Filament Mount.

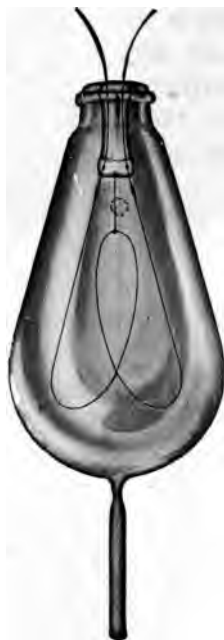

FIG. 270. — Bulb ready for Exhaust.

In this description some of the smaller steps have been eliminated, owing to limited space; but further details will be found in a pamphlet on Incandescent Lamps issued by the Sawyer-Man Electric Company, now controlled by the Westinghouse Electric Manufacturing Company. This pamphlet is designated S. M. Form No. 721. The subject is also discussed in a paper presented by E. B. Rannels before the Brooklyn section of the National Electric Light Association, Vol. I, December, 1908, page 29.

**Characteristics of Filaments.** — The termination of the useful life of a filament, or what is termed the *smashing point*, is reached when the filament falls in candle power to 80 % of its original value. The average useful life of a carbon filament lamp is about 600 hours. The carbon filament lamp possesses a *negative temperature coefficient*; that is, it has a higher resistance when cold than when hot, the resistance of a 16-candle-power carbon filament lamp of the Edison type being about 500 ohms when cold and 250 ohms when hot. This produces a lamp whose illumination falls off rapidly with a decrease in voltage, a 116-volt lamp yielding zero illumination at about 30 volts. The average wattage consumption of a carbon filament 16-candle-power lamp is 3.1 watts per candle power. By treating the filament to a higher temperature, or carbonizing it, the metallized filament, or Gem lamp, is produced, having a wattage consumption of 2.5 watts per candle power. Among the latest types of illuminants are the tantalum lamp, Figs. 271, 272, having an energy consumption of 2.25 watts per candle power, and the tungsten lamp, Fig. 275, of 1 to 1.25 watts per candle power. Since both the tantalum lamp and the tungsten lamp filaments are



FIG. 271. —  
Tantalum  
Lamp (M.  
E. S. Co.).

made of metal, they have positive temperature coefficients. Lamps having positive temperature coefficients have their

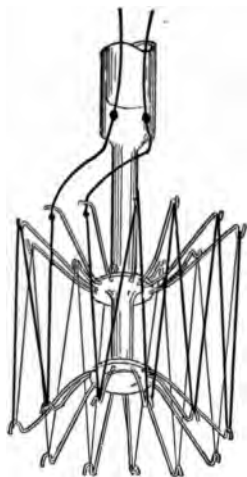

FIG. 272. — Tantalum Filament.

lowest resistance when cold. Under these circumstances a lamp such as a tungsten lamp will become luminous at a much lower voltage than a carbon lamp, the filament being visible at 10 volts. This characteristic is especially important, for if the pressure on the system should become low, due to increase in load, a tungsten lamp will yield a much higher illumination on the reduced voltage than a carbon lamp of the same candle-power unit. At 80 volts, for instance, a 116-volt tungsten lamp will yield considerable illumination, whereas a carbon lamp would be reduced to a very low

candle-power value.

**Experiment 131.** Arrange the circuit as in Fig. 273, placing ammeter shunt in series with a lamp socket, a 116-volt source of potential, and a high resistance which can be inserted by means of a fuse plug. Wire projecting galvanometer to the middle terminals of a double throw switch, and connect one side of the switch to the ammeter shunt, the other side being connected to the two terminals of the lamp through the voltmeter resistance. When the switch is thrown in one direction, the galvanometer will indicate amperes; when it is thrown in the opposite direction, it will indicate volts. Measure the resistance of carbon, tantalum, and tungsten lamps when illuminated so that they are

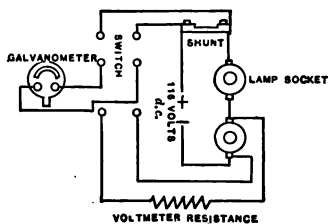

FIG. 273. — Circuit illustrating Positive and Negative Temperature Coefficient.

hardly visible, and then remove external resistance, insert the fuse plug, and measure the resistance of the lamps hot. Show that lamps change their resistance and that the resistance of the carbon lamp decreases with an increase in temperature, whereas the resistance of the tantalum and the tungsten lamps increase with increase in temperature.

**Experiment 132.** Connect a tantalum, a tungsten, a metallized carbon, and a carbon lamp in parallel, and place the combination in series with a high adjustable resistance and a 116-volt source of potential. Shunt the lamp board with a projecting voltmeter so that voltage across the lamp terminals for each adjustment of the series resistance will be indicated. Start with about 5 volts and gradually raise the pressure until it is about 150 volts, using 116-volt lamps. When the voltage is 10 volts, the tungsten filament will be visible; when the voltage is about 15 volts, the tantalum filament will be visible; when the voltage is about 25 volts, the metallized filament will be visible; and when the voltage is 35 volts, the carbon lamp will be visible. Continue the raising of the voltage, noticing that below 116 volts the carbon filament lamp increases in candle power per unit of voltage change less than the other lamps. Above 116 volts the carbon filament lamp will increase in candle power more rapidly than the others. This is due to the fact that the resistance of the other lamps above 116 volts increases with an increase in temperature, whereas the resistance of the carbon filament decreases.

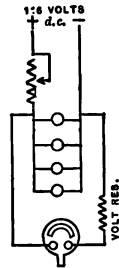

FIG. 274.—Circuit to show Variation in Candle Power with Pressure.

**The Tungsten Lamp.** — The tungsten lamp, as has been said, is one of the latest and most efficient incandescent lamps now in use. The tungsten used in making the filament of this lamp is obtained from the mineral wolfram. Wolfram is a rare mineral commonly known as tungstate of iron and manganese. As a metal tungsten naturally has a low resistance, which makes it necessary that the filament be long and fine in order to have sufficient resistance to limit the current input when connected across a 116-volt circuit. Lamps of the higher candle powers require less resistance and can therefore be made more

substantial than the small-sized units. Small candle-power units such as 16 candle power are not much used on the regular 116-volt system. They are being employed, however, for series sign lighting in which the lamps can be made for lower voltage operation and connected in series.

**The Tungsten Filament.** — The tungsten filament is made from tungstic oxide, which is obtained in an impure state as a by-product from mines in Colorado. It is mixed with iron, nickel, arsenic, etc., and is refined into pure tungstic oxide, in which state it is of a fine yellow color in the form of a powder resembling somewhat powdered sulphur. The process of reduction results in the pure tungsten metal, which is a black powder. This tungsten powder is mixed with molasses and evaporated till nearly dry; then it is rolled between steel rollers until it resembles pure rubber. The tungsten mixture is next formed into a thread by placing small pieces of it 2 inches by  $\frac{1}{4}$  inches in size into a steel cylinder, at one end of which is placed a die cut from a diamond in which is a small hole varying from 2 to 50 mills in diameter. A piston is then fitted in the other end of the cylinder and this forces the tungsten through the hole in the die and produces a fine thread. The thread is caught on a white card which the operator passes back and forth under the die in both directions, moving it far enough to produce a loop double that required for the filament. When the cardboard is filled, a knife is passed over the loops at the center, leaving a number of single loops. These filaments are packed in peat dust, baked in an atmosphere of inert gas, and treated and flashed in an atmosphere of the same gas.

The tungsten filaments are so fine and delicate that the operators have to handle them with long needles, and even with this care the great majority of them are broken before

they are mounted in the globes. This filament, owing to its fragility, is mounted in a somewhat different manner from the carbon filament. In Fig. 275 it will be noted that the filament is supported on a glass pedestal. This pedestal consists of a glass rod  $\frac{1}{8}$  inch in diameter fastened midway between the leading-in wires. Upon this pedestal are mounted two collars carrying small tantalum holders which support the tungsten filament. The entire length of the filament is about 2 feet. An objection against the tungsten lamp as first introduced was that it had to be suspended in a vertical plane because the tungsten at incandescence becomes quite soft. This defect has been remedied to a great extent through the introduction by the General Electric Company of the 25-watt lamp, in which the loops of the filament are supported at their middle so that the lamps can be placed at any angle. The tungsten lamp burns just as well on alternating as on direct current, an advantage not possessed by the tantalum lamp.



FIG. 275.  
Tungsten  
Lamp (M. E.  
S. Co.).

Owing to the small diameter of the tungsten filament it requires greater care in handling and suffers more from shocks; at present its cost is several times larger than that of the carbon lamps, but its great gain in energy consumption and its long life of 2000 lamp hours and its white light make it superior and more economical. Owing to its high intrinsic brightness (see page 189), this lamp should never be exposed directly to the field of vision. A Holophane reflector employing an 80-watt tungsten lamp with a frosted end gives a low intrinsic brightness, a beautiful illuminating effect, and an excellent distribution of light. Two such lamps properly located will light a



small store advantageously, and one such fixture will light a good-sized room in a private residence. Another desirable characteristic of the tungsten lamp is the whiteness of its light, which is due to the high temperature of its filament. Tantalum and tungsten have lower melting points than carbon, but they have *higher evaporation* points and so can be operated at higher temperatures.

**The Moore Vacuum Tube.** — Physiologically the most satisfactory illuminant is that which will cause the least harm to the eyes. This condition is fulfilled more by the

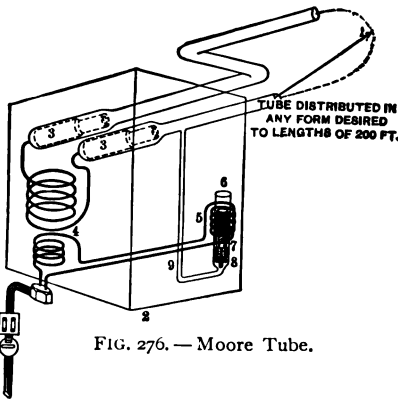

FIG. 276. — Moore Tube.

Moore tube, Fig. 276, than by any other electrical illuminant, its intrinsic brightness, *candle power per square inch of diffusing surface*, being 0.66 candle power per square inch, corresponding to 12 candle power per linear foot of tube. The Moore tube gives out a soft diffused light

closely resembling daylight when the tube is filled with nitrogen, and having a light red, orange, or salmon color. This system was invented by O. McFarlan Moore and was introduced commercially in 1903. The illuminant, as in Fig. 276, consists of a glass tube of any length up to 200 feet and  $1\frac{3}{4}$  inch in diameter of any desired form. The tube may be made up in the form of letters as for a sign, or it may extend around the ceiling of a room, being supported at intervals of 8 feet. The apparatus consists of a static transformer connected to two graphite electrodes sealed in

the ends of the tube, which is filled with air, nitrogen, carbon dioxide, or any other suitable gas. The tube containing the gas is then exhausted to a pressure of about  $\frac{1}{10}$  mm. of mercury. As the tube operates like all vacuum tubes, the vacuum becomes more and more perfect, altering the efficiency of the light, the most efficient point of which is about 0.1-0.12 mm. The conductivity of the gas, however, is a maximum at 0.08 mm. of mercury, the current consumption at this critical point being a maximum. To regulate the vacuum a separate tube projects downward from the main tube to what is termed the feeder valve, Fig. 277. The feeder valve consists of a solenoid connected in series with the primary of the transformer. This coil controls an iron plunger, raising or lowering it. The iron plunger is fastened in a glass displacing tube.

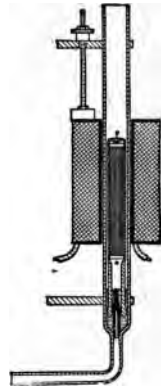

FIG. 277.—Feeder Valve for Moore Tube.

In the end of the by-pass tube is cemented a carbon plug with a small opening in it which is normally covered with mercury. As the displacing tube is moved up, the mercury recedes, uncovering the opening in the plug and allowing a small amount of air to enter the tube. As the vacuum in the tube increases, its resistance decreases, and consequently the current passing through the tube increases. An increase in the secondary current is accompanied with an increase in the primary current in the transformer (see the chapters in text on Transformers). The increased primary current increases the current passing through the series coil on the feeder valve, raising the plunger as previously described. When the vacuum is restored to normal

value by the admission of air, the current input in the primary decreases, the plunger in the feeder valve falls, and the mercury covers the opening in the plug, excluding a further supply of air. The transformer is usually operated at a primary voltage of 220 and a secondary voltage of 2200 volts. The secondary voltage varies with the length of the tube. The candle power of the tube can be varied from 0 to 50 candle power, giving normally about 12 candle power per foot of tube. The efficiency of the tube varies from 1.5 to 2 watts per candle power, varying with the length of the tube. The tube when arranged around the corners of a room is most artistic, producing a mellow light upon which the eye can gaze from time to time without apparent fatigue.

**The Cooper-Hewitt Mercury Vapor Lamp.**—The Cooper-Hewitt lamp, Figs. 278, 279, consists of a glass vacuum

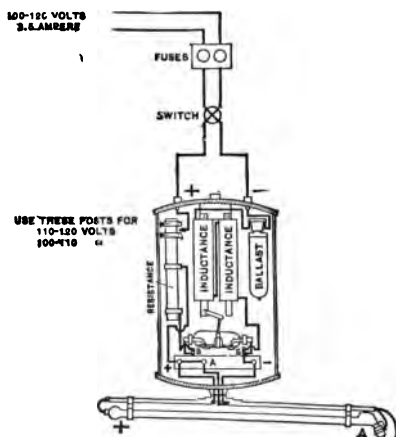

FIG. 278. — Cooper-Hewitt Tube.

tube having a mercury cathode in one end of the tube and an iron anode in the other end. Electric current is fed into the lamp through a suitable ballast resistance to two platinum wires passing through the tube to the two electrodes. The lamp operates on 115 volts direct current and takes about 6 amperes. At starting the high resistance of

the negative electrode must be overcome. Several methods have been introduced for accomplishing this, such as using

a momentary high potential from an induction coil; but the simplest and most satisfactory method is to simply tilt the tube, allowing a small stream of mercury to extend from one end of the tube to the other, the lamp lighting, allowing the tube to then return to normal position. In erecting the tube care must be taken not to screw the end clamps supporting the

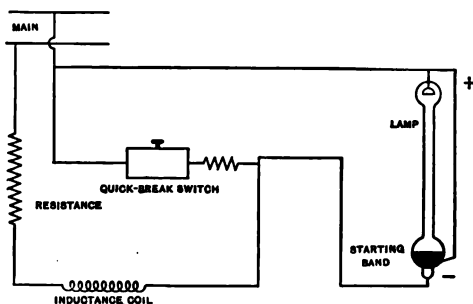

FIG. 279. — Circuits of Cooper-Hewitt Tube.

tube too tight, as the glass is necessarily thin, owing to the quick temperature changes it undergoes at starting. The lamp should in reality be classified as an arc lamp instead of an incandescent lamp, as the illumination is given off by the incandescent mercury vapor, the illumination probably resulting from some form of electro-luminescence of the vapor. As a consequence of this condition, the efficiency of the lamp is very high,  $\frac{1}{2}$  a watt per candle power, and is not affected by an increase in temperature. With proper care the life of the tube is practically infinite. The only objection urged against the tube is the fact that the absence of red rays in its illumination causes objects to appear in unnatural colors. Although this effect is objectionable so far as the personal appearance of individuals is concerned, it is highly important from a physiological viewpoint (see notes, page 197, in chapter on Arc Lights). A certain amount of induction and resistance is placed in series with the lamp, which seems to steady the arc.

**Experiment 133.** Take a spectrum chart and expose it first to a Cooper-Hewitt light and then to a tungsten lamp. Notice the change in color values.

**Experiment 134.** Take two cloths, one a deep red, and the other a black, and expose them first to the Cooper-Hewitt tube and then to a tungsten lamp and note the absence of red rays in the Cooper-Hewitt lamp.

**Experiment 135.** When the tube is lighted, hold a pointer about one foot distant from it, and notice the faint shadow cast upon the wall by the pointer. The distributing surface of the tube is so great that there is almost an entire absence of shadows. Repeat the experiment, using an arc lamp instead of the Cooper-Hewitt tube, and notice intense shadows.

**Experiment 136.** Take a small bottle of calcium sulphide phosphorescent and expose it to a Cooper-Hewitt tube. Turn off the light, and notice the phosphorescence of the bottle in a darkened room.

**The Nernst Lamp.** — The Nernst lamp, Fig. 280, is the development of Professor Walther Nernst, of Göttingen

University. Professor

Nernst developed the

Nernst lamp while investigating certain substances

such as thorium, cerium,

zirconium, erbium, ty-

thrium, and glucinum used

in the development of the

Welsbach mantle, among

which was magnesium oxide mixed with porcelain.

This is a high insulator

when cold, but a good electro-

lytic conductor when

hot. The present Nernst

glowers, Fig. 281, as manufactured by the Westinghouse

Electric Manufacturing Company, are made from kaolin.

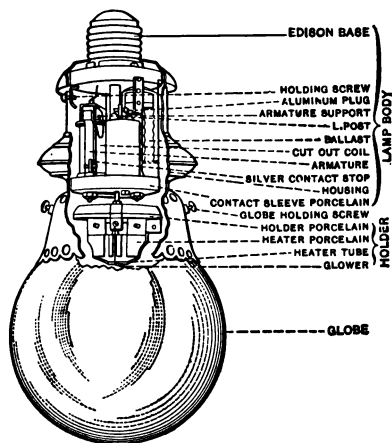

FIG. 280. — Westinghouse Nernst Lamp.

glowers, Fig. 281, as manufactured by the Westinghouse Electric Manufacturing Company, are made from kaolin.

Much difficulty has been encountered in the introduction of this lamp in America, owing to its fragile nature and the desire to make the lamp automatic in its operation. In foreign countries the lamp was introduced without the automatic starting device, the individual using the lamp heating up the glower with a match. Owing to the high resistance of the glower at starting, the lamp is provided with a heater which is shunted with the glower, Fig. 281. This heater is automatically cut out of the circuit by an electro-magnet when the glower begins to conduct. A ballast resistance, Fig. 282, placed in series with the

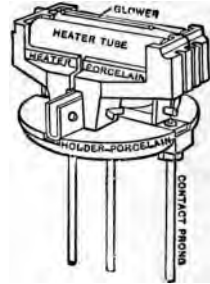
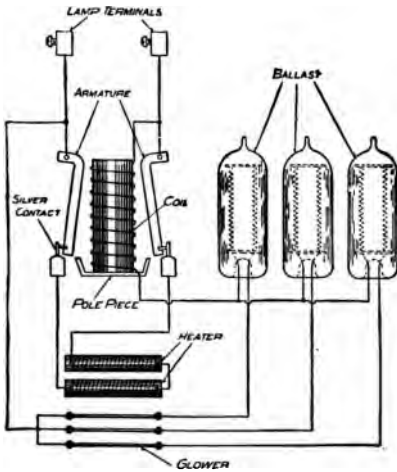

FIG. 281. — Glower.



**3 GLOWER LAMP**

FIG. 282. — Circuits for Nernst Lamp.

glower, having a positive temperature coefficient, neutralizes the decreased resistance of the glower when operating. The heater contains a coil of platinum wire. The color of the light is agreeable, being midway between the yellow and red rays of the incandescent lamp and the violet and blue of the arc light. The intrinsic brightness of the lamp is quite high, the glower necessarily being inclosed in a ground

glass globe. The life of the Nernst lamp glower is given by the Nernst Lamp Company for the alternating current

glower at 800 hours when operated at 60 cycles. There are two types of the glowers, depending upon whether they are intended for direct or alternating current operation. The ballast resistance has a life of over 20,000 hours, and the heater a life of about 8 months. The alternating current glower has received a greater development in America than the direct current glower, and consequently it has a longer life. The wattage consumption per candle power varies with the number of glowers, owing to the mutual heating effect which one glower has upon the other, the luminous radiation varying as the fourth power of the temperature (law of Stefan and Boltzman). For a 6-glower lamp, clear globes, the wattage per hemispherical candle power is 1.88. For a 3-glower lamp the value is 2.33.

#### QUESTIONS

1. What is the object of the vacuum in an incandescent lamp ?
2. Compare the carbon, metallized carbon, tantalum, and tungsten lamps.
3. What is the principle of operation of the Cooper-Hewitt tube ?
4. How does the Moore tube differ from the Cooper-Hewitt tube ?
5. Which has the better light distribution, a tube illuminant or an incandescent lamp ?
6. Explain the process of manufacture of an incandescent lamp filament.
7. What is the object of using a Holophane reflector on an incandescent lamp ?
8. Why is a tantalum lamp preferable to a carbon lamp where the voltage is likely to be below normal ?
9. Compare the color values of the various incandescent illuminants.
10. Why is it necessary with a Cooper-Hewitt lamp to tilt the tube at starting ?

## CHAPTER XIII

### RECORDING WATTMETERS AND THEIR USE

ENGINEERING practice has recognized that for commercial work the motor type of meter is the most suitable. The Edison bottle meter was used for many years. This device consisted of two zinc plates placed in a solution of zinc sulphate shunting a standard resistance, suitable resistances being placed in the circuit of the cell. The operation of this meter depended upon Faraday's law that the weight of metal deposited in a given time is directly proportional to the current used. Since the constants of the cell were known, it was therefore possible to calculate the energy used by a consumer by simply weighing the electrodes at regular intervals. Theoretically the meter was very accurate, but was finally discarded owing to the fact that the consumer could not read the meter, and that mistakes arose from improper weighing of electrodes and from rough handling of the cells. The motor type of meter (see Fig. 291 for Thomson Recording Wattmeter) consists of a motor generator. The motor element



FIG. 283. — Armature of T. R. W.

of the Thomson meter, old style, consists of a high resistance armature, Fig. 283, with no iron in



its circuit, connected through an additional resistance, Fig. 284, and compensating coil, Fig. 285, to the pressure terminals. The field coils, Fig. 286, having no iron in their circuit, are placed in series with the line. Owing to the absence of iron in either armature or field circuit, the field strength will vary directly as the current passing through the circuit, and the armature strength will vary as the potential in the circuit varies. The torque, or twisting effect of the armature, will therefore be proportional to the product of the armature and the field current, or to the armature pressure and the field current, the armature current being proportional to the pressure. As there is no iron in

FIG. 284.—Armature Resistance,  
T. R. W.

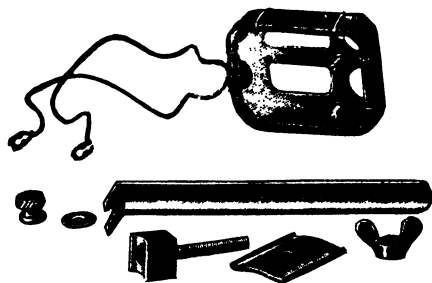

FIG. 285.—Compensating Coil.

the magnetic circuit, there is present practically no variation in flux due to saturation and no counter e. m. f. Under these conditions there would be a tendency for the speed of

the meter to keep increasing for a given energy input. This is limited, however, by the generator action produced by rotating a disc between the poles of magnets, Fig. 287, placed in the bottom of the meter. As previously stated, when this disc rotates between the poles of the magnet, an e. m. f. is generated in the disc. This e. m. f. is directly proportional to the speed of rotation of the meter, as the field strength of the magnets is constant. The e. m. f. causes a current to circulate in the disc, and this current produces a magnetic field. The current which circulates is proportional to the e. m. f. generated in the disc, since the resistance of the disc is practically constant. If the temperature of the armature, the field coils, or the disc should change during operation at heavy load, these values would change slightly. In practice this does actually occur to a slight degree. As the disc is equivalent to a conductor short-circuited upon



FIG. 286. — Field Coil, T. R. W.

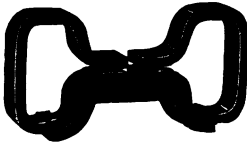

FIG. 287. — Magnets, Type C Meter.

at heavy load, these values would change slightly. In practice this does actually occur to a slight degree. As the disc is equivalent to a conductor short-circuited upon



FIG. 288. — T. R. W. Gear.



FIG. 289. — T. R. W. Gear.

itself, it is obvious that the load upon the meter will vary directly with the speed. By the combination of this



FIG. 291. — Parts of Type C-6, Thomson Recording Wattmeter.

variable speed load with the speed characteristic, and the torque of the armature being proportional to the energy input, the speed of the meter becomes directly proportional to the energy input. The speed of the meter shaft is transmitted to a chain of gears, Figs. 288, 289, recording the revolutions upon a dial. With the later kind of Thomson Recording Wattmeter, known as the Type C meter, Figs. 290, 291, many improvements have been made over the old type of Thomson Recording Wattmeter. The chief of these has been the reduction in friction. This has been accomplished by reducing the

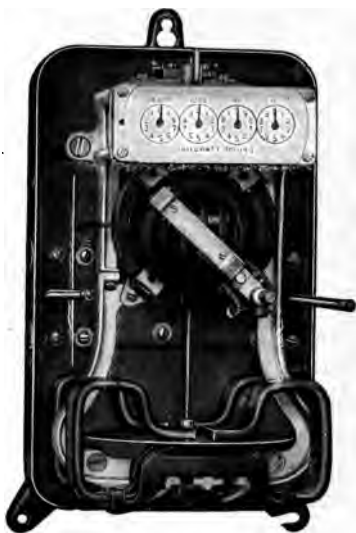

FIG. 290.—Type C, T. R. W.

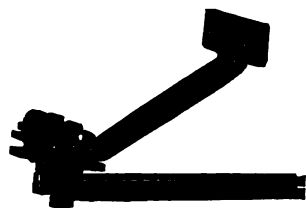

FIG. 292.—Spring Brushes,  
T. R. W.

weight of the moving element and the diameter of the commutator of the meter armature, by substituting gravity brushes for the old type of spring brush, Fig. 292, by providing a ball-shaped armature and circular field coils, and by reducing the air gap and the amount of copper required. The meter is supported by three screws instead of the four used in the old type of meter, one of the supports being central so that through gravity the meter will hang plumb. Since the covers of these meters are

removable from the front instead of from above, as with the old T. R. W., Fig. 293, the meters may be placed in small places. The wires enter from each side instead of from the bottom and are protected at their inlet points with pieces of felt to prevent dust from entering the meter. The compensating coil, the front magnet, and the field coil may be removed, readily permitting access to the armature. The frame of the meter is made of aluminum and is split,



FIG. 293. — Cover of Old Style T. R. W.

insulating material being inserted in the gap so as to prevent any possible transformer action when the meter is used on alternating currents. The armature is wound with a special wire of dipped insulation. When this wire was first used, it was found to rub off easily, but the process has been improved. This type of insulation permits of using a very compact winding. The adjustment of the compensating coil is radial, with the Type C meter, and therefore allows of closer adjustment than with the old type of meter. The magnets of the meter are arranged so that the armature is readily accessible.

**Friction of Recording Wattmeter.** — The friction of a recording wattmeter plays an important part in its accuracy. Every precaution is taken in the initial design of a meter to reduce the friction to a minimum. The movable element is set upon a steel pivot moving in a jewel bearing. Sapphire jewels are used for the low capacity meters and diamond jewels for the larger capacity meters. With the initial friction thus reduced to a minimum, means must be taken to overcome or compensate for the remaining friction. This is accomplished by means of the compensating coil, Figs. 285–290, which is placed in series with the potential circuit

of the meter. The action of this compensating coil is somewhat analogous to a series motor, having its own field acting on the armature field. This coil is shifted till its field just compensates for the friction of the meter. In other words, it is adjusted until the armature just does not turn round. Any variation in the friction of the meter, such as vibration, will obviously cause the meter to rotate slightly, although no current be passing through the fields.

**Experiment 137.** Connect a recording wattmeter up to the circuit without placing any load upon it, Fig. 294. Vary the compensating coil, noticing that the armature may be made to rotate when the position of the compensating coil is near that of the armature. Set the compensating coil so that the meter armature will not rotate. Strike the base of the meter rapidly several times and notice the movement or *creeping* of the meter. It is very important in locating meters to see that they are not placed where there is much vibration.

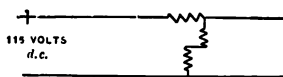

FIG. 294. — Wattmeter Circuits.

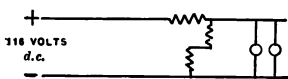

FIG. 295. — Wattmeter Circuits.

**Experiment 138.** Connect up a recording wattmeter, as in Fig. 295, to load. Vary the load upon the meter in 16-candle-power equivalents, and notice that the speed of the meter is directly proportional to its energy consumption.

In Fig. 296 are shown a set of curves obtained by Mr. Eichert, of the Edison Illuminating Company of Brooklyn, which show how the compensating coil reduces the friction loss in the meter. These curves also show how, with the induction meter, whose moving element consists of nothing more than a disc in which exists a rotating field, the friction loss is almost zero %, due to the small weight of the moving element.

**Testing Meters.** — Three methods are in common use for the testing of meters:

1. Direct method, the indicating wattmeter method, or the volt ammeter method.

2. The rotating standard method.

3. The standardized resistance method.

**The Direct Method.**—

This is the most accurate of the three methods, provided that a steady load is obtainable. This method requires the use of three instruments and a larger amount of time to test meters than some of the other methods, and it results in slight errors in observation on variable load. On the other hand, this method has certain advantages. It is comparatively easy by means of it to deter-

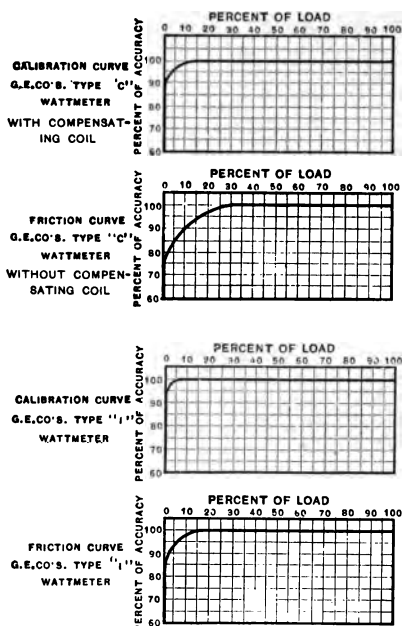

FIG. 296. — Friction Curves of Meters.

mine the exact test load; the voltmeter may be also used to locate grounds and armature trouble; the standard voltmeter, ammeter, stop watch, etc., need to be checked less frequently than other standards, and they indicate any change in the meter under test. The instruments are not so likely to be affected by stray fields from the leads of the meter under test.

**Experiment 139.** Connect up a recording wattmeter to a source of potential, Fig. 297, placing a load upon the meter, and arranging an ammeter in series and a voltmeter in parallel with the meter. Close

switch *A*, noting the time with a stop watch, and also count the revolutions of the disc. After the meter has been operating for a time open switch *A*, and calibrate the meter.

The constant marked upon the disc for small-sized meters is the watt hours per revolution of the disc. Multiply the revolutions of the disc by the disc

constant in order to obtain the watt hours. The volts indicated multiplied by the amperes by the time indicated give the watt seconds, and this amount divided by 3600 will reduce the quantity to watt hours. Compare the two sets of values of watt hours.

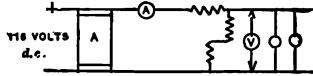

FIG. 297.— Calibrating a Meter.

**Rotating Standard Method.** — The rotating standard was first developed by Mr. Mowbray of the Brooklyn Edison Company. This meter is in reality a standard recording wattmeter which is connected in circuit with the meter under test. Upon the top of the meter is a graduated dial, over which moves a pointer attached to the spindle of the meter, indicating a fraction of a revolution of the disc. The test meter and the meter under investigation are both compared with a given number of revolutions. Different sets of field coils may be used when testing at normal load, at full load, and at light load. The percentage accuracy of the meter being tested is obtained from the following simple relation :

$$\frac{\text{actual revolutions} \times 100}{\text{allotted revolutions}} = \text{percentage of accuracy of meter.}$$

The advantages of this type of meter are its simplicity and rapidity of testing. It requires but one man to make tests and practically eliminates observation errors, recording accurately on variable load. The disadvantages of this type of meter are the necessity of checking the standard meter daily, the inability to determine slight changes in accuracy of the meter under test, the liability of the meter to be affected by stray fields from its own leads, and the



chance of error due to not properly heating the potential circuit.

The field coils of the meter may be made up in four parts as in the G. E. rotating standard. These coils may be connected in series or in parallel so as to obtain approximately the same ampere turns, resulting in the same torque for various loads. For instance, if 40 amperes are passed through the field coils connected all in parallel, 10 amperes will pass through each coil. If 20 amperes are being used, the field coils may be connected in series parallel arrangement of two sets of two coils in series, each set of coils consisting of two coils in parallel. This would likewise send 10 amperes through each field coil, as in the previous case. If 10 amperes are being tested, all of the four coils may be placed in series, in which case 10 amperes pass through each field coil. As the potential circuit is wound of copper wire, it must first be connected to the circuit for, say, ten minutes at normal load to warm up. Sometimes 100% overload is placed upon the potential circuit for a short period, as the heat generated varies as the square of the current,  $= I^2 R t \times .24$  expressed in gram-calories. A recent improvement made by Mr. Mowbray consists in increasing the ampere turns of the field and decreasing the ampere turns in the armature. An external resistance having a negligible temperature coefficient is placed in series with the armature to bring it to normal value. This reduces to a marked extent the error introduced by a change in the resistance of the armature circuit.

**Experiment 140.** Place a rotating standard in series with a service meter, and check the service meter.

**Standardized Resistance Method.** — This method consists in the use of a standardized resistance, Fig. 298. A voltmeter is used in connection with the resistance to indicate

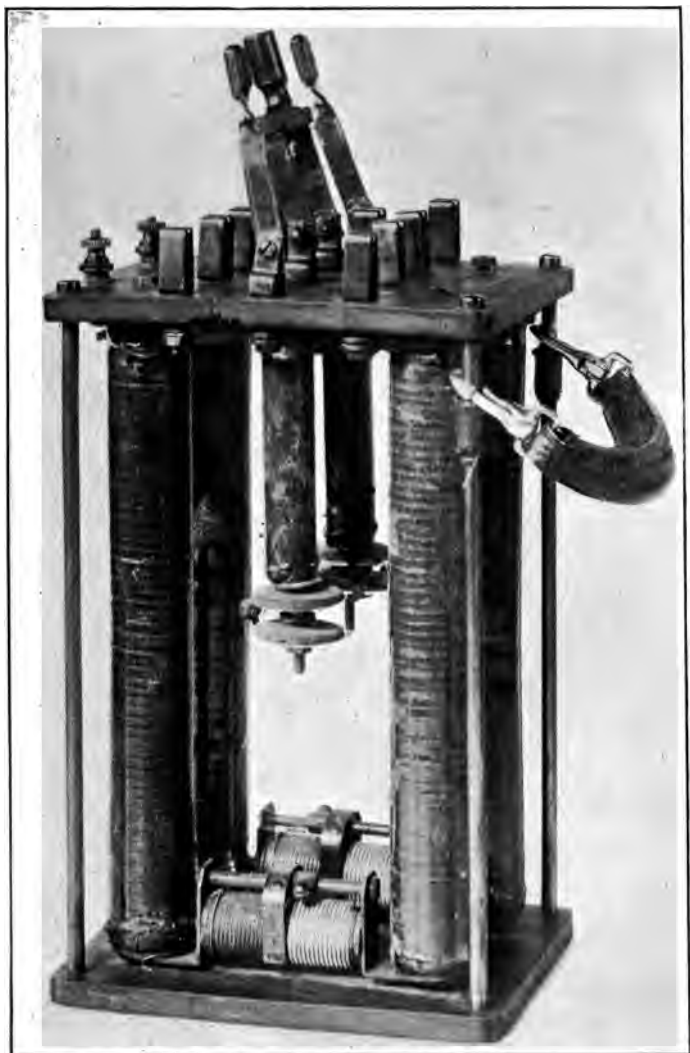

FIG. 298.—Standardized Resistance used by the Boston Edison Company.

the potential. By means of a calibration curve it is possible to determine the load when the voltmeter reading is known. The load may be varied by a simple arrangement of switches. The resistances may be wound so that they will be suitable for use on both direct and alternating cur-

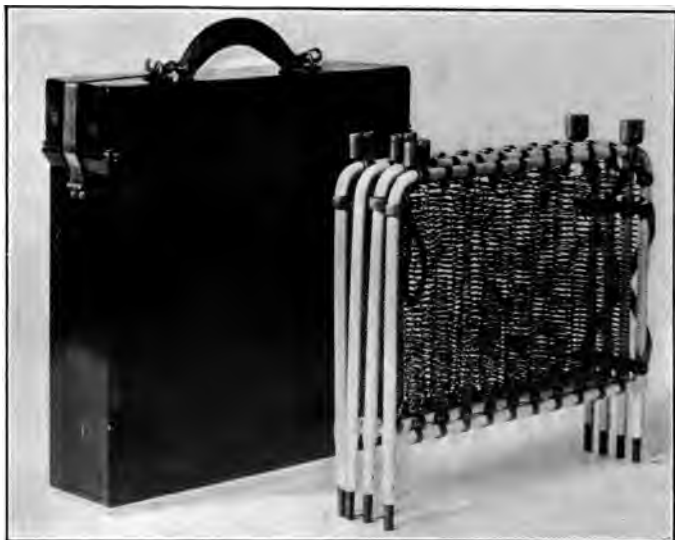

FIG. 299. — Load Box, Boston Edison Co.

rent. The resistance wire has practically a zero temperature coefficient, eliminating temperature errors. The resistance is connected across the meter similar to a regular live load, being in series with the field coils of the meter. Care must be taken with this method to have the leads sufficiently large between the meter and the resistance so as to minimize errors due to drop in potential in the leads. Voltmeters should be connected as near the potential point of the meter and the standard resistance as

possible. This method is used in conjunction with other tests by the Boston Edison Company, the New York Edison Company, and the Philadelphia Edison Company. One form of load box is shown in Fig. 298. It weighs 4.5 pounds, and has a capacity of 10 amperes. A very compact and satisfactory load box used in testing meters is that shown in Fig. 299, recently developed by the Boston Edison Co. This resistance opens out fanlike; it is very compact, and weighs but 3.5 pounds, and as the weight of the case is 2.75 pounds, the total weight of the load box is 6.25 pounds. It has a capacity of 60 amperes at 113 volts, and is made up in sections. Owing to its appearance, it is termed by the meter testers a bed resistance.

**Installation Tests.** — When a meter has been installed on the customer's premises, it is necessary before putting the meter into service or placing the fuses in position to make a few simple tests, as the customer's wiring may be short-circuited or grounded, or the field coils of the meter may be improperly connected. These tests are best illustrated by the following simple experiments.

**Experiment 141.** Let *A*, Fig. 300, be the fuse plug on a customer's premises on the service side of the meter, and let *B* be the fuse plug on the house side. Place the fuses in the service side of the meter *A*, and place an incandescent lamp in the positive fuse plug on the house side *B*. If the lamp lights, the service is grounded. If the lamp does not light place another lamp in the other fuse plug at *B*, taking care that the customer's lamps are turned off. If the lamps light at half candle power the customer's wiring is short-circuited.

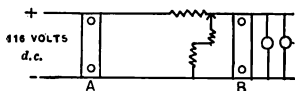

FIG. 300.—Service Tests of Meter.

With a three-wire meter one field coil is in series with each of the outside legs of the circuit. When the system is balanced, the current passing through each field coil will be the

same in magnitude. If the system is unbalanced, a greater current will flow in one leg of the circuit than in the other leg, the neutral wire carrying the difference in current on both sides of the system. When the field coils are properly connected up, the magnetic circuit of each pair of field coils will help the other along. If the field coils should by any means be reversed, the fields will work in opposition to each other, the side having the stronger field dominating the direction of motion of the meter.

**Experiment 142.** Connect up a three-wire meter to a three-wire load such as a lamp board, and reverse one of the fields, Fig. 301. Vary

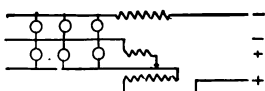

FIG. 301. — Field Coils of Meter improperly connected.

the load upon the meter, first having one side and then the other carry the greater load. Notice that the meter will rotate first in one direction and then in the other. This experiment is very important as illustrating the fact that it is impossible by merely noting the direction of rotation of a meter when installed to determine whether or not the field coils are properly connected. If the direction of rotation is to be taken as an indication of correct installation, some idea of the distribution of the load must also be had.

**Inspection Tests.** — When a meter has been in use for some time, it is necessary to test it. The frequency of these tests depends upon whether a direct current meter or an alternating current meter is in question and also upon the capacity of the meter. The schedule used by one of our largest lighting companies is as follows: direct current meters up to and including 25 amperes capacity require one test a year; those of from 50 to 100 amperes require two tests a year; those of 100 amperes and above require four tests a year. Alternating current meters, single phase, are tested as follows: those of all capacities require one test every two years; polyphase meters of all capacities require

two tests a year. The meters of special customers who use the current 24 hours a day are tested once a month.

**How to make Tests.** — Meters should be tested on three loads,—on light load, on normal load, and on full load. For light load 10 % of the meter capacity is used, for full load from 50 to 100 % of the meter capacity is used, for normal load from 20 to 100 % of the customer's installation or commercial load is used. The Public Service Commission of New York recommends the following schedule in determining the normal load from the connected load :

NORMAL LOAD

CLASS	TYPE	% OF INSTALLATION
<i>A</i>	Residences and Apartments	25
<i>B</i>	Churches and Offices	45
<i>C</i>	Elevators	20
<i>D</i>	General Stores	60
<i>E</i>	Signs	100
<i>F</i>	Blowers	100
<i>G</i>	Theaters	60
<i>H</i>	<i>A</i> and <i>C</i>	25
<i>I</i>	<i>B</i> and <i>C</i>	40
<i>K</i>	<i>C</i> and <i>D</i>	50
<i>L</i>	<i>D</i> and <i>E</i> or <i>F</i>	70
<i>M</i>	{ Motors except <i>C</i> and <i>F</i> Arc Lights }	Load in use, otherwise 50

Having tested a meter on each of these loads, the average per cent accuracy may be found by taking the light load *A*, plus the full load *B*, plus 3 times the normal load *C*, and dividing by 5, giving the average per cent,

$$\frac{A + B + 3C}{5} = \text{average per cent.}$$

Where alternating current meters are to be installed on inductive load, they are tested on a 60% power factor in the testing room before being installed.

**Load.** — While it is possible to use the customer's load as a test load in checking a meter, this is undesirable and

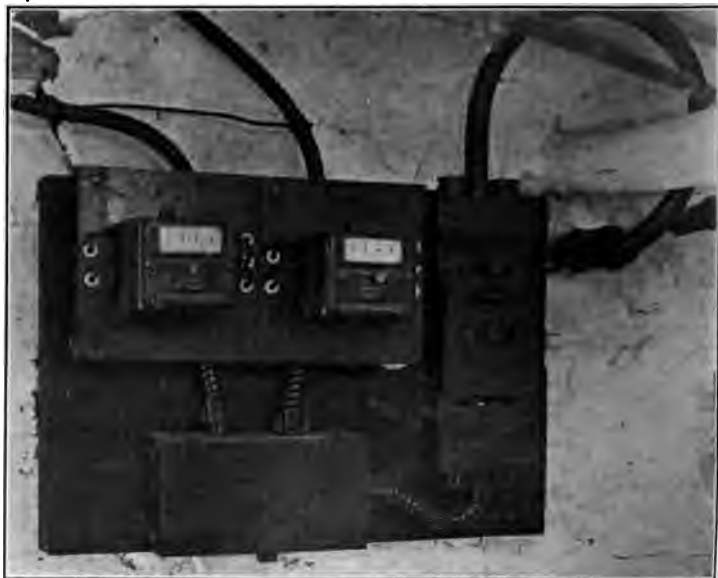

FIG. 302. — Typical Meter Installation, Alternating Current Service.

inconvenient. Various loads, such as portable resistances, water rheostats, lamp boards, load boxes, etc., may be used. The customer's load is shunted while the meter is being tested. A small set of storage batteries may be used for testing meters, such as 500-volt meters, using a carbon rheostat to regulate the current. Small and compact step-down transformers may also be used for testing alternating current meters, employing the transformer as a load.



FIG. 303. — Typical Service of Meters.

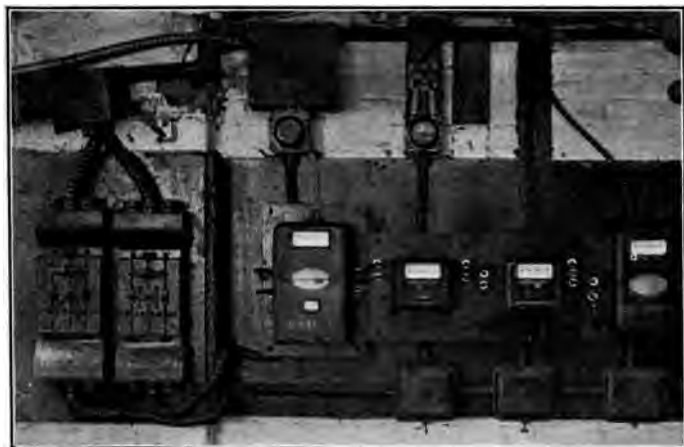

FIG. 304. — Combination Direct Current and Alternating Current Service.



**Meter Installations.** — The capacity of a meter to be installed in any place depends upon the size and character of the connected load. Meters with few exceptions have



FIG. 305. — T. R. W. and Type C. Meter Service.

a smaller capacity than the connected load, as overmetering not only increases the cost of meter installations, but results also in a loss to the company. This is due to the

fact that the meter with a small capacity will register a small load more advantageously than a larger capacity meter, the tendency for the larger meter being to run slow on light loads. As a rule, a meter of 50% of the customer's capacity is satisfactory, for it is seldom that more than one half of the installation is in service at one time, except perhaps when some special function is occurring. One manager has said that it is good economy to



FIG. 306. — Typical Direct Current Service.



FIG. 307. — Single A. C. Service.

burn out a meter occasionally. Where, as in signs, all of the customer's lamps may be lighted simultaneously, the meter should be of the same capacity as the installation. This is also true of some motor loads. The table on page 235 gives some idea of the relation between the connected load and the normal load. Care must be taken to consider the overload capacity of a meter in all cases. The starting current may be excessive



compared with the installed capacity of the load, as with motors on elevator service. In such cases the motors may

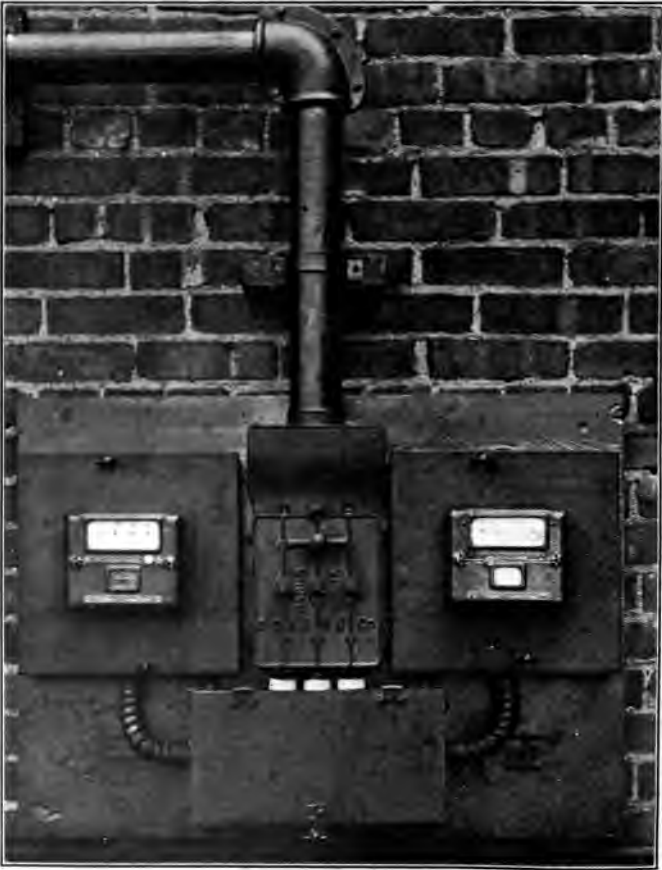

FIG. 308. — Typical Meter Installation.

be started and stopped frequently, and a capacity 25% greater for the meter than the installed capacity of the motors may be necessary.



**Meter Wiring.** — In addition to the ordinary requirements in the installation of a meter, such as accessibility and absence of dampness and vibration, the meter should be installed so that its position will be permanent, and so that it will be safe and cannot be tampered with. Formerly too little attention was devoted to this phase of the subject. Recently, however, considerable advance has been made in this direction by housing the meter in sheet-iron boxes and the service switches in metal boxes, and inclosing the immediate wiring in the vicinity of the meter in a conduit. Specimens of this new development in meter installation are shown in Figs. 302–308, as developed by Mr. J. W. Lafferty for the Brooklyn Edison Company.

#### QUESTIONS

1. Give the principle of operation of the recording wattmeter.
2. What is the function of a compensating coil ?
3. Why does a short circuit on the system often alter the accuracy of the meter ?
4. In making meter tests, why is it important not to have the test leads too near the meter ?
5. Give the principal methods of testing meters, with their relative advantages and disadvantages.
6. What is meant by the light load adjustment of a meter, and what is meant by the full load adjustment ?
7. How would you test the jewel of a meter to see whether it is perfect ?
8. What is meant by the creeping of a meter and how may it be obviated ?
9. What advantages does the motor type of meter possess over an electrolytic meter for commercial work ?
10. How may the jewel of a meter be protected during transportation ?



## CHAPTER XIV

### ELEMENTARY PRINCIPLES OF ALTERNATING CURRENTS

AN *alternating current* differs from a direct current in that an alternating current continually reverses its direction of flow with a regular periodicity. An alternating current starts from zero, flows in one direction, the current gradually rising from zero to a maximum value, and then falling again to zero. When it reaches zero, it changes its direction of flow, rising to a maximum again, and falling again to zero. This fluctuation of the current, flowing first in one direction and then in another, continues with a definite sequence, the sequence being very rapid. For normal practice it may be 25 or 60 times a second. The *period*, or complete cycle of operations, is so rapid that arc lamps and incandescent lamps may be operated upon it without an inexperienced observer being able to tell whether the current supply is direct or alternating. In an alternating current circuit two other factors besides *resistance*, namely, *inductance* and *capacity*, affect the operation of the circuit. Both of these factors are also present in a direct current circuit, but they come into play in the direct current circuit only when there is any change in the current flow. Thus, when a direct current circuit is closed, the current does not rise instantly to its normal value if inductance is present in the circuit, but a definite time interval elapses before the current reaches normal value. This time interval is quite short for most circuits, but in a large generator it can easily amount to one second. This point can be



readily demonstrated by closing and opening a field switch, leaving it closed for various small time intervals. At first a small spark will occur which will increase with increased time intervals to an arc. A better conception of an alternating current circuit may be had from the following simple experiment.

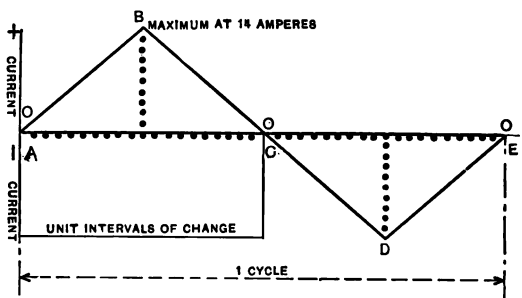

FIG. 309. — Instantaneous Current Curve.

**Experiment 143.** Connect a dry battery of 1.4 volts potential to a resistance of 1 ohm. According to Ohm's law, 1.4 amperes will pass through the circuit. Gradually increase the number of cells, one at a time, until 10 are in circuit, and the current will increase to 14 amperes. (This will be only approximately true, as the internal resistance of the cells has not been considered; but if a storage battery is used, it will be much more exact.) Then gradually decrease the number of cells in circuit, one at a time, until zero current is reached. Reverse the connections so that when the circuit is again closed the current will flow in the opposite direction, and continue the process as before, the currents rising to a maximum and then falling. If we plot a curve for this operation in terms of the number of changes and the current value obtained for each change, we shall obtain a curve like Fig. 309. This curve has five distinctive points, *A*, *B*, *C*, *D*, *E*. Points *A*, *C*, and *E* are zero values, and points *B* and *D* are maximum values. Points above the line may be called positive, and points below the line may be called negative. This complete operation of positive and negative values is termed a *cycle*, and the curve may be termed a curve of *alternating current*. In an alternating current generator, the changes in current

flow are not so abrupt or irregular, as in Fig. 309, the change being uniform and smooth, following a *sine* law, as in Fig. 310. When a coil of wire is wound upon an armature and rotated in a magnetic field (Fig. 311), the terminals of the coil being connected to slip rings, which in turn are connected to a resistance, such as a lamp, the current which will pass through the circuit will be somewhat of the shape of Fig. 310. This is due to the fact that the magnetic flux which passes through the armature is greatest at the centers of the poles, and is practically zero between the poles. The same effect may be illustrated in another manner.

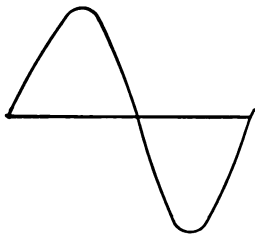

FIG. 310.—Sine Curve.

**Experiment 144.** Take a solenoid of a large number of turns (Long Tom), and connect it to the terminals of a galvanometer, as in Fig. 312. Arrange a bar magnet so that it can be moved in and out of the coil, causing the pointer of the galvanometer to deflect, first in one direction and then in the opposite direction, due to the e. m. f. generated in the coil. It will also be

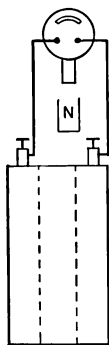

FIG. 312.—Generating an Alternating E. M. F.

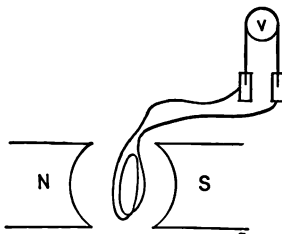

FIG. 311.—Generation of E. M. F.

noticed that when the magnet is plunged into the coil, the needle will deflect in one direction, and when it is withdrawn from the coil, it will deflect in the opposite direction. If the speed of motion of the magnet is increased to a maximum, and then decreased to zero in the forward motion, and if this occurs likewise in the return motion, a series of deflections will result. If it were possible to plot these, they would fall on a curve similar to Fig. 310.

**The Contact Maker.**— Electro-motive force and current curves for actual machines in practice may be obtained by means of contact makers operating in conjunction with some means of balancing and of reading the poten-

tial. The contact maker, Figs. 313, 314, consists of two metal rings mounted one over the other, with insulation between, on the end of a shaft, which is supported in bearings and connected through a flexible coupling to the shaft of the machine being tested. In the outer ring is

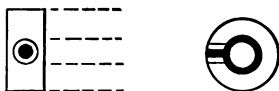

FIG. 313. — Contact Maker.

bored a hole, through which passes a circular rod connected into the inner ring, passing through the insulation between. The hole through the outer ring must be of



FIG. 314. — Contact Maker.

sufficient size so that an air space will surround the rod, insulating it from the ring. The top of the rod is flush with the surface of the outer ring. A copper brush presses against the top surface of the outer ring, making electrical contact between the two rings as the contact maker rotates. The brush is mounted upon a movable ring which is graduated, the ring turning about the same axis as the contact maker. It is thus possible to set the contact maker so that it will close the circuit at any point of a revolution, the exact position being readable on the vernier scale attached. Pressing against the side of the outer ring is a brush also, which completes the circuit of the contact maker, as the inner ring is of the same potential as the frame of the machine. The brush pressing against the outer ring may be mounted upon an insulated arm, so that the brush will simply be the push button of the circuit. In taking a series of observations, the contact maker brush is set at various positions, such as every  $5^\circ$ , or  $(360/5 =) 72$  readings for one revolution. These degrees, however, are mechanical degrees and not electrical degrees, except where a two-pole machine is used. If a four-



pole machine were used, each mechanical degree would equal two electrical degrees; if an eight-pole machine, each mechanical degree would equal four electrical degrees,

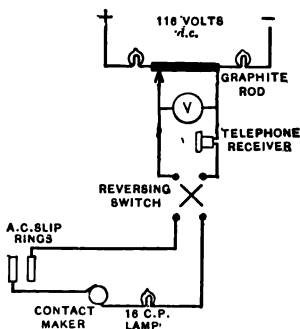

FIG. 315.—Using a Balance Set to obtain E. M. F. Curve.

etc. Each pair of poles is equivalent to 360 electrical degrees, as shown in Fig. 309. Bearing in mind that the potential of the generator at the particular fraction of a second that the circuit is closed by the contact maker may be either positive or negative, and of any magnitude from zero to a maximum, the question arises as to how this potential may be measured. In Fig. 315 is shown a 116-volt direct current circuit connected through two 16-candle-power lamps to a carbon rod which has a high resistance, about 3000 ohms. When the circuit is closed, the lamps will not light up, but will have a resistance of from 400 to 500 ohms each. Assuming a combined resistance for the lamps of 1000 ohms, and a resistance of the rod of 3000 ohms, it is evident on a 116-volt direct current circuit that the potential would distribute itself over the circuit in the proportion of 29 volts for the lamps and 87 volts for the rod. If 240 volts were connected across the circuit, the potential would rise across the rod to over 200 volts, as the lamps would partially light up, their resistance falling

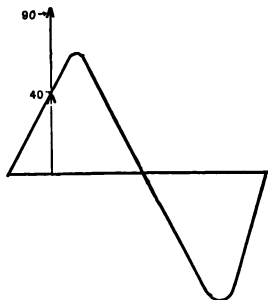

FIG. 316.—Method of Balancing E. M. F.'s.

quite perceptibly. If one terminal of the rod is connected to a voltmeter, then to a telephone receiver, and then from the telephone receiver to one pole of a switch, and another sliding contact on the rod is connected to the other terminal of the voltmeter, and then to a 16-candle-power lamp, through the lamp to the other terminal of the switch, we shall obtain an adjustable potential circuit, which may be connected through the contact maker to two slip rings of the alternating current generator. The switch in the circuit should be of the reversing type so that the direction of the direct current can be changed when desired. Readings taken with the switch in one position may be termed positive values, and readings taken with the switch in the opposite direction may be termed negative values. Sliding the contact along the graphite rod will give a variable potential, whose value will be indicated on the voltmeter. The alternating e. m. f. for a given setting of the contact maker will have a finite value, as previously stated, of from zero to its maximum value, and will be either positive or negative. Assume that the value to be measured is 40 volts positive, Fig. 316. To balance this potential in the circuit so that no current will flow either into the generator or out of the generator at the instant that the contact maker closes the circuit, a potential of 40 volts positive direct current must oppose it. When a balance is obtained, no current will flow through the telephone receiver, and no sound will be heard; if a balance is not obtained, the click of the contact maker will be heard. To balance, the main switch is closed, and the telephone receiver is placed to the ear, the sliding contact being moved over the graphite bar. If the switch is in the wrong position, the sound in the receiver will be intense, due to the fact that the direct current will be trying to

assist the alternating current. As the contact is moved along, the sound in the receiver, that is, the characteristic click, will gradually diminish in intensity, until 40 volts is reached in this case, when the sound will be either zero or at a minimum. On sliding the contact beyond this point, the sound in the receiver will increase. A little practice in the handling of this apparatus will enable an observer to estimate his value before he makes a balance, and to know whether his curve is rising or falling, and when he is crossing zero; in the latter case, he will need to throw his reversing switch.

**Experiment 145.** Make a set-up as described above, and obtain a potential curve for an alternating current machine. If the alternating current machine happens to be a rotary converter, it will be necessary to connect a 1 : 1 transformer in the generator leads coming to the contact maker, before this same direct current potential, upon which the machine is operating, can be used to balance. When the readings are obtained, plot a curve using degrees for the horizontal axis, or *abscissa*, and voltage readings as indicated on the voltmeter as the vertical axis, or *ordinate*.

**Experiment 146.** Place a non-inductive resistance in the generator circuit such as a standard ohm and a lamp board, permitting about five amperes to flow through the generator circuit. Use an additional double throw switch, connected into the circuit, as in Fig. 317, so that simultaneous pressure and current curves may be obtained. Plot both sets of values on the same sheet, and notice that maximum and zero values of both current and pressure values correspond, these values occurring at the same time intervals.

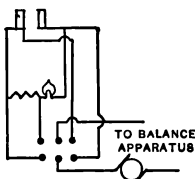

FIG. 317. — Balance Apparatus.

**Oscillograph.** — The *oscillograph*, one type of which is made by the General Electric Company, may be used to obtain the wave shapes of current and potential circuits; it has an advantage over the contact maker in that the wave shapes may be made visible if the phenomena are

recurring, and in that they may be photographed if the phenomena are either recurring or transient. The principle of the apparatus is quite simple. It consists of a flexible suspension in the form of a loop of fine wire mounted between the poles of an electro-magnet. Upon this suspension is mounted a small mirror about  $\frac{1}{16}$  inch square. This suspension is connected through resistance to the circuit about to be measured, the amount of resistance in the circuit of the electro-magnets and in the suspension circuit being determined by the amplitude of the deflection desired. The current through the electro-magnets should be about 1.5 amperes as a maximum. A ray of light is sent into the oscillograph box through the side, where it strikes a  $45^\circ$  prism, the beam being turned at right angles where it is focused upon the mirror. The arc lamp should be operated with small millimeter cored carbons so that the arc will remain steady. Be sure at any rate that the upper carbon, or positive, is cored. The light reflected from the mirror comes back through a slit in the back of the oscillograph, where it moves over the film as it rotates. For visual use a small induction motor on the side of the oscillograph rotates a sector and also vibrates a prism so that the rays are reflected vertically where they may be observed on the observation plate. Since the motion of the prism is about an axis at right angles to the motion of the mirror, the curve is spread out so as to be visible. The oscillograph is arranged usually with three separate suspensions so that various current pressure and time relations may be observed. When the film carrier is in use, an electrical contact on the axle of the carrier opens and closes the shutter, regulating the exposure as desired. Ordinary photographic films may be used, a 6-exposure film making two exposures for the oscillograph. Care

should be taken in loading the film carrier to be sure that you have the emulsion side of the film outward and to overlap the film so that, when it is rotated, the top flap of the film will move past the exposure opening in the oscillograph and not catch in the opening, as it is likely to do if the film has been mounted wrong. In using the oscillograph, since there are usually six switches which have to be closed before an exposure is made, it is well to write out the series of steps closing the switches in 1, 2, 3, 4, 5, 6, order. This is especially important where one person only is operating the oscillograph.

**Effective Values.** — In an alternating curve of instantaneous e. m. f.'s, Fig. 310, there are various values which may be considered, — the *zero values*, the *maximum values*, the *average value*, and the *effective value*. In commercial work we are interested in two values particularly, the maximum value and the effective value. Most portable instruments, such as ammeters and voltmeters (Fig. 318), are constructed to indicate effective values. The effective value is known as the *square root of the mean square value*. The effective value of an alternating current circuit is such an alternating current as would have the *same heating value as a given direct current*. Mathematically, the maximum value divided by the square root of two gives the effective value.

$$\text{Effective value} = \text{maximum}/\sqrt{2}.$$

$$\text{Effective value} = \text{maximum}/1.41.$$

To find the effective value for a given sine curve obtained from an alternating current machine by means of a contact maker, proceed as follows. Take a certain number of values — 20 of the original curve — and square them. Plot over the original curve a current squared curve, using the same abscissa but different ordinates. Divide up this

curve into rectangles, and calculate as closely as possible its area. If a planimeter is at hand, it may be used to obtain the area. Having determined the area in square inches, divide the area by the abscissa, or the length along the zero line between two successive zeroes, and obtain the mean height of the curve in inches. Plot this value vertically on the curve, and determine its equivalent value in current squared units. This will then give the mean square current



FIG. 318. Interior of Weston Alternating Current Voltmeter.

value. Extracting the square root of this quantity will give the effective value, or *the square root of the mean square value*. An effective current value of 100 amperes alternating current would have the same heating effect as 100 amperes of direct current. The heating effect of a direct current circuit is thus expressed :

$$U = I^2 R t \times .24,$$

where  $U$  is given in gram calories,  $I$  in amperes,  $R$  in ohms,

$t$  in seconds, and .24 is *Joule's coefficient*. One gram calorie is the amount of heat required to raise the temperature of one gram of water  $1^{\circ}\text{C}$ .

The relation between the maximum value and the average value may be given as follows :

$$\text{maximum} = \pi/2 \times \text{average} = 1.57 \times \text{average}.$$

(For the mathematical proof of this equation, see Steinmetz, *Alternating Current Phenomena*, page 13. Trigonometry is used only in the proof.)

**Form Factor.**—The *form factor* of an alternating current wave is the relation existing in the given wave shape between its average and its effective values. It is usually given in the form of the following ratio :

$$\text{F. F.} = \text{effective/average}.$$

In the sine curve the value becomes  $.707/.636 = 1.11$ . The value  $.707 = \frac{1}{\sqrt{2}}$ . This equation for form factor for a sine curve may also be written

$$\text{F. F.} = \frac{\frac{1}{\sqrt{2}} E_{\text{max.}}}{\frac{2}{\pi} E_{\text{max.}}} = 1.11.$$

**Alternating Current Generators.**—Alternating current generators are of three types :

1. Alternators with a stationary field winding using a revolving armature.
2. Alternators having a stationary armature and a revolving field winding.
3. Alternators having a stationary armature and a stationary field winding using a rotating element termed an inductor.

TYPE 1 is used for small machines, and consists in substituting slip rings for the commutator of small direct current generators. A small two-pole motor may have two slip rings mounted upon its shaft on the opposite side of the armature to the commutator and tapped into the armature winding at two points, as in Fig. 319. This produces a single-phase machine employing two slip rings. To produce a three-

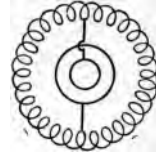

FIG. 319. — Single-phase Generator.

phase machine, employing three-phase e. m. f.'s, as in Fig. 320, three taps  $120^\circ$  apart, Fig. 321, connected to three slip rings, are used.

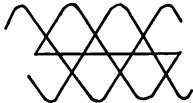

FIG. 320. — Three-phase E. M. F.

TYPE 2. In this form of machine there are no slip rings except for the excitation of the revolving field winding, the armature which usually supplies high potential being well insulated and connected directly to the main line.

TYPE 3. This type of machine, Fig. 322, termed an inductor generator, has likewise no slip rings for the armature winding, the latter being connected directly to the line. The principle of operation here employed is

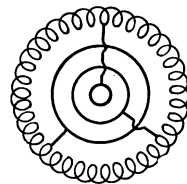

FIG. 321. — Three-phase Generator.

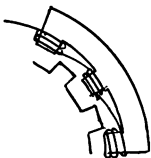

FIG. 322. — Inductor Generator.

that a series of iron poles on the rotating element will first span one set of armature and field windings lying between, and then lie in between the next set of windings, causing the flux to rise from a minimum to a maximum value without changing in sign. As the field winding lies in between the armature windings, the rise and fall of the flux generates an alternating e. m. f. in the armature winding. In



Fig. 322 only one set of the armature windings is shown; the field windings lying in back of these armature windings are likewise not shown. A complete description of these machines may be found in Sheldon's *Alternating Currents*, pages 136-139.

Detailed tests illustrating the characteristic curves and performance of alternators may be found in Bedell's *Direct Current and Alternating Current Testing*, pages 62-102.

**Capacity.**—When a two-conductor cable is connected up to a direct current source of potential and no load is on the cable, a certain flow of electrical energy occurs, lasting for a short interval of time. If this cable be

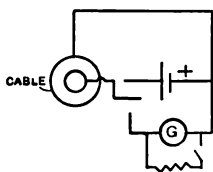

FIG. 323. — Experiment showing charging of Cable.

disconnected from its direct current source, and be allowed to discharge through a galvanometer, Fig. 323, a deflection of the galvanometer will occur, lasting for some time. This deflection is so severe on a service cable that it is customary to short-circuit the galvanometer at first and then to open the circuit after a certain time interval. This experiment

indicates that a certain amount of energy has been stored somewhere in the cable. What actually occurs is that a displacement current flowing through the dielectric of the cable creates a bound charge in the dielectric and a free charge on the plates. The effect produced, Fig. 324, is termed *electrical polarization*, the latent charge in the dielectric being separated into positive and negative elements. But electrical polarization should not be confused with the term

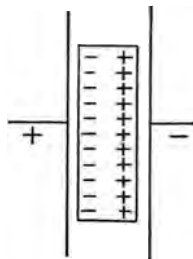

FIG. 324. — Dielectric Polarization.

*polarization* as applied to an electrolytic cell. In the former case the two charges, positive and negative, are bound, being held in equilibrium, while in the case of the cell the positive and negatively charged ions are actually split apart, traveling to the electrodes of opposite polarity. The effect just described is termed the effect of *capacity*. It is to be found not only in cables, but in all electrical apparatus where two conductors are separated by a dielectric. Forms of apparatus consisting of conducting foil or plates separated by air, or by some dielectric, such as paper or glass, are used for various electrical purposes and are termed *condensers*. The unit of the capacity is the *farad*. A condenser whose potential can be raised to one volt by one coulomb (one ampere flowing for one second) is said to have a capacity of one farad. The microfarad ( $\frac{1}{1000000}$  farad) is used in practice, as the farad is too large for ordinary use.

**Experiment 147.** Connect a telephone condenser of 2.5 microfarads in series with a switch, a direct current source of potential of about 60 volts, and a galvanometer, Fig. 325. Close the switch and notice the "kick" of the galvanometer. Disconnect from the source of potential the charged condenser, and connect its terminals directly to the galvanometer. Notice the "kick" of the galvanometer as the condenser discharges. When the condenser is once charged, it may be said to have an infinite resistance to direct currents of constant potential.

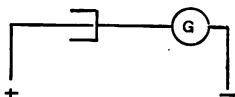

FIG. 325. — Experiment showing charging of Condenser with Direct Current.

**Effect of Capacity in an Alternating Current Circuit.** — Consider an alternating e. m. f., as in Fig. 326, to be connected to the terminals of a condenser, and assume that its wave shape will be as shown. Assume that the condenser possesses no initial charge and that it is connected

to the circuit when the e. m. f. is passing through the zero point. Since there is no initial charge in the condenser to resist the flow of energy into it, the rate of flow of current into it at this same instant of time will be a maximum. The

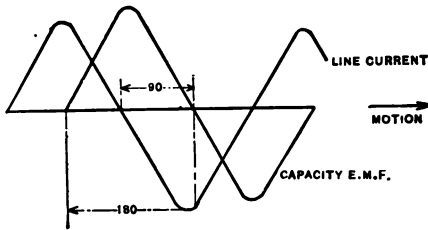

FIG. 326. — Capacity and Current Relations.

effect is somewhat analogous to that produced by steam discharging into a vacuum, where its velocity may be 30,000 feet per minute. As the flow of current into the condenser

continues, its potential increases, and this, acting like a counter e. m. f., tends to cut down the current flow, the charging current falling to zero when the alternating potential has reached its maximum value. When the line potential starts to fall, the condenser potential, because greater for the instant, tends to discharge back into the circuit, and the discharge increases in magnitude as the alternating potential falls, and reaches its maximum value when there is zero initial alternating potential to resist it. From this discussion it may be noticed that there is a continual charging and discharging of the condenser, the condenser at one instant taking energy from the circuit, and at the next giving it back. If we represent the cycle of e. m. f. in Fig. 326, by  $360^\circ$ , dividing it up into four elements of  $90^\circ$ , and consider that the direction of motion is to the right, it will be observed that the capacity e. m. f. lags the line current (crossing zero)  $90^\circ$ . The relation between the line current and the e. m. f. due to capacity in a circuit may be represented by means of their effective values in the form of vectors, as in Fig. 338.

The mathematical expression for the e. m. f. due to capacity in a circuit may be obtained in the following manner :

Let  $C$  be the capacity in a circuit.

Let  $e$  be the potential of the capacity when charged.

Let  $f$  be the frequency of the circuit.

Then  $Ce$ , or capacity times potential, according to our definition, will represent the charge expressed in coulombs which the condenser accumulates. In a cycle of alternating current, it is evident that if the condenser is connected to an alternating current circuit it will be charged and discharged 4 times per cycle  $f$ . The average rate of charge could then be expressed as  $4f$ . This rate of charge, however, must be converted from average rate to maximum rate.

$$\text{Maximum} = \frac{\pi}{2} \text{ average.}$$

$$\text{Maximum rate of charge and discharge} = \frac{4\pi f}{2} = 2\pi f.$$

Multiplying the rate by the charge  $Ce$ , we obtain

$$I = 2\pi fCe, \quad \frac{I}{e} = 2\pi fC, \quad I = \frac{e}{\frac{1}{2\pi fC}},$$

where  $I$  = the current passing through circuit.  $I$  and  $e$  are both effective values.

**Problem.** What is the capacity reactance  $x$  of 50 microfarads of capacity in an alternating current circuit of 60 cycles ?

$$x = \frac{1}{2\pi fC} = \frac{1}{2 \times 3.14 \times 60 \times .00005} = 53.2 \text{ ohms.}$$

*Capacity reactance*,  $\frac{1}{2\pi fC}$ , is expressed in ohms. If resistance is present in the circuit, its value in ohms must be combined vectorially with the capacity reactance in ohms

to obtain the equivalent effect. For instance, a capacity reactance of 4 ohms and an ohmic resistance effect of 3 ohms would result in an equivalent effect of 5 ohms. The capacity reactance is plotted graphically as in Fig. 338, where it is  $90^\circ$  out of phase with the ohmic resistance effect. Squaring both sides of the right-angled triangle, and extracting the square root of their sum, we have

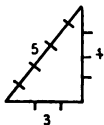

FIG. 327.—Relation of Sides in Right-angle Triangle.

the value for the hypotenuse of 5 ohms.

Thus,

$$\begin{aligned} 3^2 &= 9 \\ 4^2 &= 16 \\ \hline \text{Total,} & \quad 25 \\ \sqrt{25} &= 5, \end{aligned}$$

sum = 25 ; square root of sum = 5.

**Series Parallel Combinations of Condensers.**—Condensers when placed in series, Fig. 328, tend to decrease, in inverse proportion, the total capacity of the system. The effect is just opposite to resistance circuits where two resistances placed in series have a combined resistance equal to their sum.

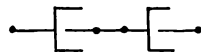

FIG. 328.—Condensers in Series.

**Experiment 148.** Place a 2.5-microfarad condenser in series with a projecting galvanometer and a 60-volt source of direct current potential, and note the deflection of the galvanometer on closing the switch. Place two 2.5-microfarad telephone condensers in series in a similar manner, and notice that the deflection of the galvanometer on closing the switch is half as great as before. Discharge the condensers in both cases through the galvanometer, and notice that the deflection reduces to  $\frac{1}{2}$  in the latter case.

When condensers are placed in parallel, Fig. 329, their capacity increases proportionally in a similar manner

to series resistances. Two equal resistances placed in parallel have an equivalent resistance equal to  $\frac{1}{2}$  of one of the resistances. Two equal resistances placed in series have a combined resistance equal to their sum. Two condensers of equal capacity placed in parallel have a combined capacity when operating equal to their sum. Two condensers of equal capacity placed in series have a combined capacity equal to  $\frac{1}{2}$  of the value of one of them. The capacity of cables used for underground distribution is therefore directly proportional to their length, and their charging current will likewise increase as their length increases. It will be shown later that capacity reactance and inductance in an alternating current system may be made to balance each other. In practical operation the capacity of the system is fixed, as the length of the cables when once installed is fixed. Inductance is added to the system or taken from it by varying the field rheostats on the converters, motor generators, generators, etc., until a balance occurs and unity power factor exists. For a series combination of condensers their equivalent sum can be obtained mathematically as follows:

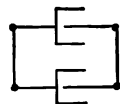

FIG. 329. — Condensers in Parallel.

$$c = \frac{I}{\frac{I}{c^1} + \frac{I}{c^2} + \frac{I}{c^3}}$$

**Self-induction.**—As has been said, self-induction is present in a direct current circuit as well as in an alternating current circuit, and it affects the circuit whenever there is any change in the current flow or the flux of the circuit. When the flux in a circuit changes, owing to a change in the current flow, the flux cuts the turns of wire that produce the field, causing an e. m. f. to be induced in

the winding. The magnitude of the induced e. m. f., termed the e. m. f. of self-induction, depends upon two things: first, the quantity  $L$  termed the coefficient of self-induction, or *the number of lines of force linked with the circuit per absolute unit of current*; and second, the quantity  $\left(\frac{di}{dt}\right)$ , which expresses the rate of change of the current. It can readily be seen that the quantity  $L$  is dependent upon the original strength of the field or the number of ampere turns, whereas the quantity  $\left(\frac{di}{dt}\right)$  is dependent upon the current flowing in the circuit, and the frequency with which it rises and falls from maximum to zero, and zero to maximum.  $L$  is usually expressed in *henry's*. The *henry* may be defined as that constant by which the time rate of change in a circuit must be multiplied in order to give the e. m. f. induced in that circuit. One henry exists in a circuit when a current varying one ampere per second produces one volt of e. m. f. in that circuit. In practice the henry is so large that a smaller unit, the millihenry, or  $\frac{1}{1000}$  of a henry, is used. The e. m. f. of self-induction may then be expressed by the formula

$$E_s = -L \left( \frac{di}{dt} \right).$$

The negative sign here is due to the fact that this e. m. f.,  $E_s$ , is a counter e. m. f.

**Example.** Being given a current in a circuit which changes from 0 to 100 amperes in .005 second, and assuming that the counter e. m. f.,  $E_s$ , is 15 volts, what would be the coefficient of self-induction of that circuit?

If the current varies from 0 to 100 amperes in .005 second, the quantity  $\frac{di}{dt}$  would become  $\frac{100}{.005} = 20,000$ ; or the time rate of variation

of the current would be 20,000 amperes in a second. The equation would then become, substituting 15 for  $E_s$ , and 20,000 for  $\frac{di}{dt}$ ,

$$15 = L(20,000),$$

$$L = \frac{15}{20000} = .00075 = .75 \text{ millihenry.}$$

The following interesting example is given in Foster's Handbook, page 65. A coil of wire of 150 turns is carrying 2 amperes and producing a field of 200,000 lines of force. If it takes the current 1 second to die out when the circuit is opened, what will be the e. m. f. of self-induction induced in the circuit? If 2 amperes produces a field of 200,000 lines of force, 1 ampere will produce 100,000 lines of force. If it takes the current 1 second to die out, then each turn would cut 100,000 lines of force in that time, and 150 turns would be equivalent to 1 turn cutting 15,000,000 lines of force in a second. As 1 volt equals 100,000,000 lines of force cut per second, an e. m. f. of  $\frac{15,000,000}{100,000,000}$ , or .15 volt, would be generated, or .15 henry.

From the above example and from the definition of the coefficient of self-induction,  $L$ , it will be observed that the value of  $L$  may be expressed in terms of the flux, the turns, the current, and  $10^8$  power, as follows:  $10^8 = 100,000,000$ .

$$L = \frac{\text{flux} \times \text{number of turns}}{\text{current} \times 10^8} = \frac{\phi N}{I\sqrt{2} \times 10^8}$$

$I\sqrt{2}$  = maximum amperes, where  $I$  = effective amperes.

In an alternating current circuit the e. m. f. of self-induction,  $E$ , is expressed in terms of the frequency,  $f$ , the current,  $I$ , the coefficient of self-induction,  $L$ , and the constant,  $2\pi$ , in the following manner:

$$E = 2\pi fLI.$$



This equation may be obtained by considering a coil of wire in which an alternating current is passing, the coil having  $n$  turns, inclosing a flux  $\phi$ , the current having a frequency  $f$ . Then the average e. m. f.,  $E$  avg., which would be induced in this coil, would be

$$E \text{ avg.} = \frac{4f\phi N}{10^8}.$$

As the flux would rise and fall from zero four times in a cycle, so four times the flux, times the turns, times the frequency or cycles per second, would give the total lines of force cut in one second. Dividing this by  $10^8$  (100,000,000 lines of force cut in one second equals one volt) gives the average e. m. f. generated. To find the effective voltage, the voltage usually used, it is necessary first to find the maximum e. m. f.,  $E$  max., from the average value. It may be remarked incidentally that the equation above for  $E$  avg. is the *fundamental* equation for alternators, transformers, induction motors, and practically all alternating current apparatus.

From page 257 we have the maximum value  $E$  max. equal to  $\frac{\pi}{2} E$  avg. and the effective e. m. f.,  $E_f = \frac{E \text{ max.}}{\sqrt{2}}$ .

$$E \text{ max.} = \frac{\pi}{2} E \text{ avg.}; \quad \frac{\pi}{2} = \frac{3.1416}{2} = 1.57;$$

$$E_f = \frac{E \text{ max.}}{\sqrt{2}}; \quad \sqrt{2} = 1.41.$$

The average value of an a. c.-e. m. f. is .633 times as great as its maximum value, and the maximum value is 1.41 times as large as the effective value. Alternating current voltmeters indicate effective values.

Simplifying,

$$\left( \frac{4f\phi N}{10^8} \times \frac{\pi}{2} = \frac{2\pi f\phi N}{10^8} \right),$$

$$E \text{ max.} = \frac{2\pi f\phi N}{10^8};$$

as  $2 = \sqrt{2} \times \sqrt{2}.$

then  $E_f = \frac{\sqrt{2} \times \sqrt{2} \pi f\phi N}{10^8} \times \frac{1}{\sqrt{2}} = \frac{\sqrt{2} \pi f\phi N}{10^8}.$

$$E_f = \frac{\sqrt{2} \pi f\phi N}{10^8}.$$

From page 261

$$L = \frac{\phi N}{I\sqrt{2} 10^8} \quad \text{or} \quad \phi N = LI\sqrt{2} \times 10^8.$$

Substituting for  $\phi N$  in above formulæ,

$$E_f = \frac{\sqrt{2} \pi f LI \sqrt{2} 10^8}{10^8} = 2 \pi f LI.$$

$$E_f = 2 \pi f LI.$$

In this equation  $E_f$  is expressed in volts,  $f$  in cycles per second,  $L$  in henrys, and  $I$  in effective amperes.

This e. m. f. of self-induction,  $E_f$ , in an alternating current circuit tends to lead the a. c. current in the circuit by  $90^\circ$ , Fig. 330. In considering the total e. m. f. required to send an alternating current through an inductive circuit, we find that the e. m. f. is made up of two parts, the e. m. f. necessary to overcome the resistance of the circuit, and the counter e. m. f. of self-induction induced in the circuit. In considering the operation of a shunt motor, it may be remembered that a counter e. m. f. was also present and that this e. m. f. was

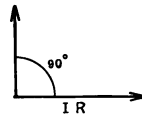

FIG. 330.—Relation of Resistance and Inductive E. M. F.

subtracted from the line e. m. f. in order to determine the e. m. f. forcing current through the armature resistance, or  $\frac{e - e'}{r} = I$ . The counter e. m. f. of a motor is, therefore,  $180^\circ$  apart from its line e. m. f., but the e. m. f. of self-induction

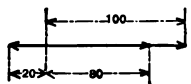

FIG. 331. — Line E. M. F. direct current voltage in a motor armature of 80 volts.

In Fig. 332 is shown a line e. m. f. of 100 volts, an inductive e. m. f. of 20 volts, and an e. m. f.  $A$  to overcome resistance of

$$\begin{aligned} 100^2 &= 20^2 + A^2, \\ A^2 &= 100^2 - 20^2, \\ A &= \sqrt{100^2 - 20^2} = 97.9. \end{aligned}$$

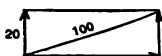

Fig. 332. — Resistance and Inductive E. M. F.'s.

To show that the e. m. f. of self-induction is  $90^\circ$  ahead of the current, consider the alternating current curve  $ABCDE$ , Fig. 333. It may be remembered that in order to have an e. m. f. induced in a winding it is necessary that the flux should change. In the curve, Fig. 333, there are two points,  $B$  and  $D$ , where the current is neither increasing or decreasing. At these two instants of time, theoretically, the current must be stationary and the flux must be stationary, result-

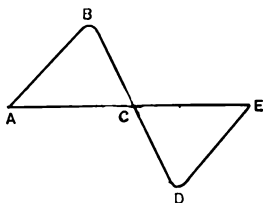

FIG. 333. — Alternating Current E. M. F. Curve.

ing in zero e. m. f. of self-induction being generated. When the current begins to fall from  $B$ , the flux being in phase with it, the e. m. f. of self-induction assumes a greater and a greater value as the curve becomes steeper, until when the

current is passing through zero, the flux is changing at its maximum rate, the e. m. f. of self-induction being a maximum, as shown in Fig.

334. As a single lobe of an alternating current wave is represented by  $180^\circ$ , it will be noticed that, considering the motion to be toward the right, the curve of self-induction passes through the zero line  $90^\circ$  before the current has crossed the zero line.

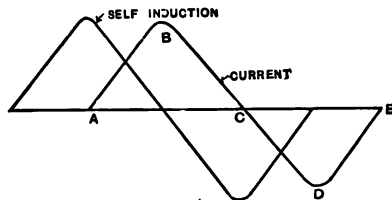

FIG. 334.—Relation of Current and Induction E. M. F.'s.

As the e. m. f. which overcomes the resistance of a circuit is in phase with its current, it may be stated that the e. m. f. of self-induction is  $90^\circ$  ahead of the a. c. current in the circuit. These values may be represented in terms of effective values instead of instantaneous values, vectors being used, as in Fig. 332, the inductive e. m. f. leading by  $90^\circ$  the resistance e. m. f.

**Experiment 149.** Place a coil of a large number of turns but of low resistance (Long Tom) in series with a 16-candle-power lamp and a direct current source of potential. Notice that the lamp will light to practically full intensity, but that it is a little sluggish in so doing. Substitute then an alternating current source of supply of 60 cycles of about the same potential for the direct current potential, and notice that the illumination of the lamp is almost reduced to zero. Introduce an iron core in coil and extinguish lamp. Vary it in and out. If 25 cycles is used, the low tension windings of two 20-light Type H Transformers placed in series will form a suitable inductance.

**Experiment 150.** Vary frequency with same set-up and notice that inductive reactance increases with an increase in frequency. A small rotary converter operated from the direct current side with a field rheostat in circuit forms a suitable method of varying the frequency.

**Experiment 151.** Form a series circuit of condensers, inductance, and a 16-candle-power lamp. Vary inductance until a maximum of

candle power is reached. In this case the capacity reactance neutralizes the inductive reactance. About 40 microfarads of capacity is a suitable amount of capacity to use.

**Experiment 152.** Measure with a projecting voltmeter the e. m. f.'s across the individual units of the previous set-up and show vector relation. Notice that sum of e. m. f.'s is greater than line e. m. f. Plotting the  $90^\circ$  relation of inductive reactance, resistance, and capacity reactance, the resultant may be obtained.

**Experiment 153.** Form a multiple circuit of inductance, resistance, and capacity. Potential across elements of circuit will be the same. Measure individual current values with projecting ammeter. Notice that line current is less than sum of individual currents. Calculate admittance (see page 272) and plot vectors. When current passing through inductance is alone indicated, add capacity in parallel and notice that ammeter reading becomes smaller.

**Experiment 154.** With first inductance and then capacity alone in an alternating current circuit, calculate coefficient of self-induction  $L$  and capacity  $C$ . It is necessary to know the frequency of the circuit, the current passing through the device, and the potential across it.

**Vectors.**—It is convenient in considering alternating current circuits to represent the current and pressure values by means of vectors. A vector is an arrow, Fig. 335, which may be considered to rotate in a *counter-clockwise* direction, whose length represents to convenient scale the



effective value of electromotive force or current, and whose direction with some other vector represents the angular phase displacement between the two. Thus, in Fig. 336, is shown graphically the relation between the e. m. f. of self-induction,  $2\pi fLI$ , and the current  $I$  in the circuit. The angle of lag  $\theta$  of the current  $I$  behind the e. m. f. is in this case  $90^\circ$ . Figure 337 shows an e. m. f. in phase with the current. This condition holds in

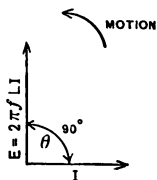

FIG. 336. —Vector Relation of Inductance and Current.

an alternating current circuit containing only resistance. Figure 338 illustrates a circuit containing capacity in which the current leads the capacity reactance by  $90^\circ$ . A three-phase circuit in which the e. m. f.'s are  $120^\circ$  from each other may be shown as in Fig. 339. This is termed a Y connection. A delta connection is shown in Fig. 361. Usually the delta connection

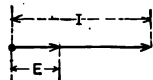

FIG. 337.—E. M. F. and Current in Phase.

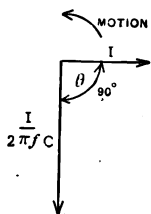

FIG. 338.—Vector Relation of Current and Capacity Reactance:

is shown as an equilateral triangle. The relation between the primary e. m. f., the secondary e. m. f., and the flux of a transformer may be represented as in Fig. 340, the primary and secondary e. m. f.'s being  $180^\circ$  apart. A more lucid exposition of the subject applied to transformers may be found in the chapter on transformers.

Where resistance is present alone in an alternating current circuit the e. m. f. representing the difference of potential across the terminals of the resistance is in phase with the current, the conditions being similar to a direct current circuit, Fig. 341.

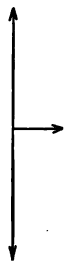

FIG. 340.—Relation of Transformer E.M.F.'s

Where inductance and resistance are both present in the circuit, the e. m. f. required to send a current through the circuit is made up of two components, Fig. 342. In this diagram  $AB$  is the e. m. f. vector  $RI$  necessary to overcome the resistance of the circuit,  $AD$  is the current vector  $I$  in phase with the resistance e. m. f.,  $CB$  is the inductive e. m. f. vector,  $2\pi fLI$ , at  $90^\circ$

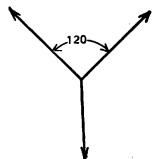

FIG. 339.—Y Connector of Three-phase Circuit.

at  $90^\circ$

to the resistance e. m. f., and  $AC$  is the resultant e. m. f.  $E = I \sqrt{R^2 + (2\pi fL)^2}$  equal to the vector sum of the other two e. m. f.'s in the circuit. The value  $AC$  is obtained by

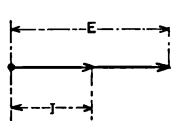
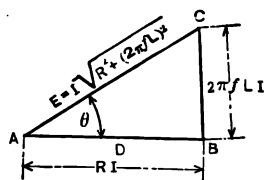

FIG. 341. — Resistance alone in Alternating Current Circuit.

taking the square root of the sum of the squares of the other two sides, this being the familiar geometrical relation for the hypotenuse of a right-angled triangle in terms of its other two sides. Thus, if one side is 3, the other side 4, the hypotenuse will be 5. The angle  $\theta$ , Fig. 342, represents the

amount the current in the circuit  $I$  lags behind the resulting e. m. f., or the line e. m. f.,  $E$ . It will be noticed that the extent of this phase displacement

depends upon the relative magnitude of the vectors  $AB$  and  $BC$ . If  $AB$  is large and  $CB$  small, that is, if the inductance of the circuit is small compared with its resistance, the



phase displacement will be small. If the vector  $BC$  be large compared

with  $AB$ , the angle will be large. The latter condition is met with in a Type I, Thomson Recording Wattmeter, where two fields are produced by two windings, one a highly inductive winding, the resultant field being rotating.

Another thing may be noticed about Fig. 342, and that is that the sum of the two vectors  $AB + BC$  is greater than  $AC$ . A straight line is the shortest distance between two points. In other words, the sum of the individual e. m. f.'s in a circuit may be greater than the line e. m. f.,  $AC$ .

**Trigonometric Expressions.** — In trigonometry we have a means of expressing the relations of the sides of a right-angled triangle in terms of its central angle. This relation is expressed by what are known as *sines*, *cosines*, *tan-*

gents, these being used more frequently than other trigonometric expressions. In Fig. 343 the *sine* of the angle  $\theta$  is equal to  $BC$  divided by  $AC$ , the cosine by  $AB/AC$ , the tangent by  $BC/AB$ . The ratios just given are definite for any acute angle. Tables are prepared which give the values of sines, cosines, tangents, etc., for different angles.

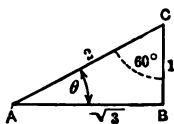

FIG. 343.— Trigonometric Relations in a Right Triangle.

In alternating current work one is concerned mainly with angles of  $30^\circ$ ,  $45^\circ$ , and  $60^\circ$ . In an equilateral triangle such as is formed by the vectors of a  $\Delta$  three-phase circuit the angles between the vectors are  $60^\circ$ , and the sides are equal. If we drop a perpendicular from one of the angles, we form a right triangle, as in Fig. 343, whose sides we can designate by the numerals 1, 2,  $\sqrt{3}$ , for the square of 1 is 1, the square of the  $\sqrt{3}$  is 3, the square of 2 is 4;  $4 = 1 + 3$ . In this right triangle one has a  $30^\circ$  and a  $60^\circ$  angle. The sine, cosine, and tangent are therefore as follows:

$$\sin 30^\circ = \frac{CB}{AC} = \frac{1}{2} = .5 = \cos 60^\circ;$$

$$\cos 30^\circ = \frac{AB}{AC} = \frac{\sqrt{3}}{2} = .866 = \sin 60^\circ;$$

$$\tan 30^\circ = \frac{CB}{AB} = \frac{1}{\sqrt{3}} = .577;$$

$$\tan 60^\circ = \frac{AB}{CB} = \frac{\sqrt{3}}{1} = \sqrt{3} = 1.732.$$

From the above it is evident that the sine of one angle is equal to the cosine of its complementary angle. Thus sine of  $30^\circ$  equals cosine of  $60^\circ$ , subtracting  $30^\circ$  from  $90^\circ$ .

Where a  $45^\circ$  right triangle is used, two sides may be



designated by the numerals 1, and the third side by the  $\sqrt{2}$ , in which case the sine and cosine are both equal to  $\frac{1}{\sqrt{2}}$ .

It is evident that by the use of trigonometry in an alternating current circuit, if the angle of phase displacement of line e. m. f. and current is known and the line e. m. f. is also known, the inductive e. m. f. and the resistance e. m. f. may be determined, if they alone are present. For instance, in Fig. 342,

$$\begin{aligned}\sin \theta &= \frac{BC}{AC} = \frac{2 \pi f L I}{I \sqrt{R^2 + (2 \pi f L)^2}} = \frac{2 \pi f L}{\sqrt{R^2 + (2 \pi f L)^2}}; \\ \cos \theta &= \frac{AB}{AC} = \frac{RI}{I \sqrt{R^2 + (2 \pi f L)^2}} = \frac{R}{\sqrt{R^2 + (2 \pi f L)^2}}; \\ \tan \theta &= \frac{BC}{AB} = \frac{2 \pi f L I}{RI} = \frac{2 \pi f L}{R} = 2 \pi f \frac{L}{R}.\end{aligned}$$

The ratio  $\frac{L}{R}$  is sometimes called the *time constant* of a circuit. Numerically it is equal to the time necessary for the current to rise to  $\frac{2}{3}$  of its maximum value. For a given  $R$ , the greater  $L$  is, the longer will be the time necessary to reach this value or the larger will be the time constant.

The above equations may be rewritten in the form,

$$\begin{aligned}BC &= AC \times \sin \theta; \\ AB &= AC \times \cos \theta; \\ BC &= AB \times \tan \theta.\end{aligned}$$

**Alternating Current Circuits containing Resistance, Inductance, and Capacity.** — It has been shown in previous paragraphs that in an alternating current circuit containing resistance, inductance, and capacity, the e. m. f.'s across the

terminals of each of these elements in a series circuit is equal to  $RI$ ,  $2\pi fLI$ , and  $\frac{I}{2\pi fC}$ . The graphical representation of these elements in a series circuit is illustrated in Fig. 344, where the resistance vector  $AC$  leads the capacity reactance vector  $AD$ , and lags the inductive vector  $AB$ .

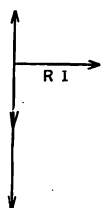

FIG. 345.—Vector Relation of E. M. F.'s.

Since the effect of capacity in the circuit is opposite to the effect of inductance, these two vectors may be subtracted from each other, or added vectorially.

Whichever is the greater dominates the phase displacement in the circuit. If the capacity reactance is greater than the inductive reactance, Fig. 345, the current in the circuit will lead;

if, on the other hand, the inductive reactance is the greater, Fig. 346, the current will be lagging. Instead of plotting vectors in terms of e. m. f., their value in ohms may be used, and this will eliminate the quantity  $I$ . Thus, when the inductive reactance vector and the capacity reactance vector have been added, the parallelogram may be completed as in Fig.

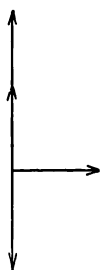

FIG. 346.—Effect opposite to Fig. 345.

347, the resulting line  $AB$ , or the diagonal of the parallelogram, representing the algebraic sum of the three vectors and the

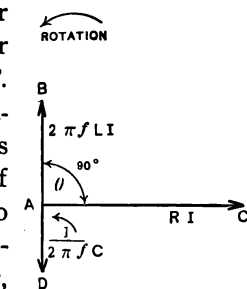

FIG. 344.—Vector Relation of E. M. F.'s.

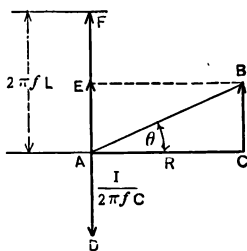

FIG. 347.—Ohmic Relation of Resistance and Reactance.

representing the algebraic sum of the three vectors and the

impedance of the circuit. Analytically this process may be represented as follows :

$$AD = \frac{I}{2\pi fC}, \quad AF = 2\pi fL, \quad AC = R,$$

$$AE = 2\pi fL - \frac{I}{2\pi fC}, \quad AB = \sqrt{R^2 + \left(2\pi fL - \frac{I}{2\pi fC}\right)^2}.$$

$AB$  is usually represented by the letter  $Z$ .

$$Z = \sqrt{R^2 + \left(2\pi fL - \frac{I}{2\pi fC}\right)^2}.$$

When  $2\pi fL = \frac{I}{2\pi fC}$ , the quantity  $\left(2\pi fL - \frac{I}{2\pi fC}\right)^2$  reduces to zero, in which case  $\sqrt{R^2} = R$ , or  $Z = R$ , the conditions, so far as ohmic effect is concerned, being similar to those in a direct current circuit. This condition is termed *resonance*. When a resonant condition does not exist, the e. m. f. current relations can be shown by the relation

$$I = \frac{E}{Z} = \frac{E}{\sqrt{R^2 + \left(2\pi fL - \frac{I}{2\pi fC}\right)^2}}.$$

The quantity  $\frac{I}{2\pi fC}$  is expressed in ohms and is termed the *capacity reactance* of the circuit. The quantity  $2\pi fL$  is expressed in ohms and is termed the *inductive reactance* of the circuit, and the quantity  $\left(2\pi fL - \frac{I}{2\pi fC}\right)$  is also expressed in ohms and is termed the *reactance* of the circuit. It is sometimes represented by  $X$ . The reciprocal of the impedance  $\frac{I}{Z} = Y$  is termed the *admittance*. In order to combine reactances, Fig. 348, which are in parallel, it is necessary first to determine their admittances

and their phase relations, plotting them vectorially, Fig. 349. In this case we plot current values, while in a series circuit potential values are used, for in the case of admittances  $I_1 = E Y_1$ , and  $I_2 = E Y_2$ , etc., where  $I$  and  $E$  are the current and e. m. f. values and  $Y_1, Y_2$  are the admittances. The polygon will then assume the form of Fig. 349. For specific examples, see Sheldon's *Alternating Currents*, page 89, and Hay's *Alternating Currents*, page 21.

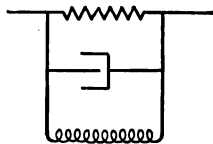

FIG. 348.—Parallel Reactances.

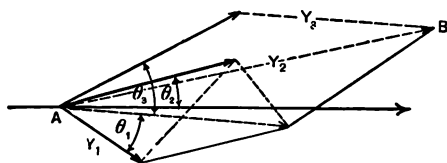

FIG. 349.—Vector Relation of Admittances.

**Power of an Alternating Current Circuit.** — The power of an alternating current single-phase circuit, irrespective of the phase relation of current and electromotive force in the circuit, can be obtained from a consideration of the instantaneous values of pressure and

current in a similar manner to a direct current circuit. For example, if at a given instant of time we multiply together the corresponding values of current and pressure, we obtain a true value in watts for the power at that particular instant. From this fact it will be noticed that the power in an alternating current circuit is continually changing, rising from zero to a maximum, and decreasing to zero again, as shown in Fig. 350.

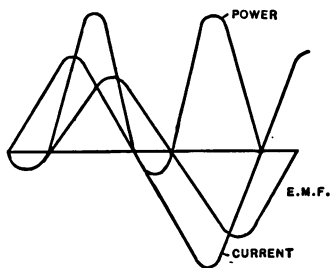

FIG. 350.—Power in a Single-phase Circuit.

350. The power curve will have positive values when both

current and pressure values are positive,  $+ \times + = +$ , and positive values when both current and pressure values are negative,  $- \times - = +$ . If current and pressure values are positive and negative, the power will be negative,  $+ \times - = -$ . When the power is positive, the generator is supplying power to the line; and when the power is negative, the line is returning power to the generator. Thus, in a single-phase system, there are times when power is being returned to the system. In a three-phase system this condition does not occur. The amount of power returned in a single-phase circuit depends upon the phase difference of the current and pressure. If the angle of lag be as much as  $90^\circ$ , the power returned (negative loop) will be equal to the power delivered (positive loop). The power absorbed during a quarter period is returned to the circuit during the next quarter period. This condition of a  $90^\circ$  lag is impossible, however, in any single-phase circuit containing resistance, as it requires some power to overcome this resistance. The ordinary Thomson Recording Wattmeter will indicate the true power in a single-phase circuit because the magnetic strength of current and pressure coils will vary with the instantaneous values of current and pressure in the circuit and the resulting torque of armature will vary with the instantaneous power in the circuit. A more compact meter,

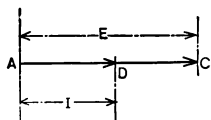

FIG. 351.— E. M. F. and Current in Phase.

such as the G. E. Type I, utilizing the lagging effect of self-induction, is used, however, for alternating current single-phase power measurements. With this meter, to be described later, the weight of the moving element is reduced to a minimum, thus obviating as much as possible the loss due to friction. When the e. m. f. and the current are in phase, as in a circuit containing only resist-

ance, Fig. 351, the product of the two vectors will give the true power in the circuit. In a circuit in which the e. m. f.  $AD$  and the current  $AC$  differ in phase, Fig. 352, by the angle  $\theta$ , the projection of the vector  $AD$  on  $AC$  or  $AB$  (obtained by dropping a perpendicular from  $D$  to  $AC$ ) must first be obtained before the product  $AB \times AC$  will yield the power in watts in the circuit. Considering that  $ABD$  is a right-angled triangle, the relation of  $AB$  to  $AD$  may be expressed in terms of the angle  $\theta$ ,

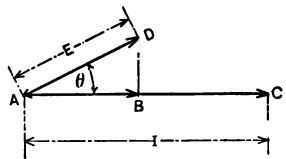

FIG. 352.—E. M. F. and Current out of Phase.

$$AB/AD = \cos \theta,$$

or  $AB = AD \times \cos \theta.$

**Power Factor.** — As has already been stated, the power of an alternating circuit containing inductance and capacity cannot be obtained by simply multiplying together the effective values of current and pressure, as might be done in the case of a direct current circuit.

The quantity  $\cos \theta$ , derived above, is termed the *power factor of the circuit*. When the angle  $\theta = 0$ , or when  $AD$  and  $AC$  coincide, Fig 353, the power factor is *unity*,  $\cos 0^\circ = 1$ , for the cosine of Fig. 353 is expressed  $AB/AD$ ; as  $AB$  will equal  $AD$  when part of the same straight line  $AB/AD = 1$ . In practice power factors of alternating current circuits, if supplying arc lamps, are about 85%. Where a large induction motor load is on the system, the power factor may be as low as 60%. Where motor generators are used employing synchronous motors, the power factor is greatly improved.



FIG. 353.—Unity Power Factor.

This is one of the chief advantages urged for the use of the synchronous motor.

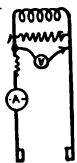

FIG. 354. — Experimental Method of measuring Power Factor.

To obtain the power factor of any circuit such as an inductance, an ammeter, a voltmeter, and a wattmeter may be used as in Fig. 354. The ammeter and current coil of the wattmeter are placed in series with the inductance and a source of alternating potential, and the voltmeter and potential winding of the wattmeter shunt the device. Calling the wattmeter reading  $P$ , the voltmeter reading  $E$ , and the ammeter reading  $I$ , the power factor may be obtained as follows:

$$P = EI \cos \theta;$$

$$P = E \times I \times \text{power factor};$$

$$\frac{P}{E \times I} = \text{power factor}.$$

**Experiment 155.** Measure the power factor of an alternating current arc lamp, using a wattmeter, ammeter, and voltmeter. Do not measure the arc voltage, but rather the voltage across the whole lamp. The power factor should be about .85.

When operating alternating current machinery, it is always desirable to operate as near unity power factor as possible, otherwise an additional current will flow in the circuit, unnecessarily heating the windings. It is evident that where the power factor is other than unity a certain amount of energy representing the true power in the circuit is dissipated, whereas other energy, not dissipated and termed *wattless* energy, is pumped back and forth in the circuit. This energy is stored in the magnetic field at one instant in the circuit and returned to the generator at the next instant.

**Power Measurements in a Three-phase Circuit.**—On a three-phase circuit two wattmeters may be used to measure power, the current coil of each wattmeter being placed in one phase, Fig. 355. The potential coils of each wattmeter are connected from the phase wire, in which the current coil is located, to the common third phase wire. With this connection the sum of the two wattmeter readings equals the total power in the circuit. For power factors below .5 the reading of one wattmeter will be negative, the total power being the arithmetical difference of the two readings. The power factor of a balanced three-phase circuit may be obtained by means of the tangent formula

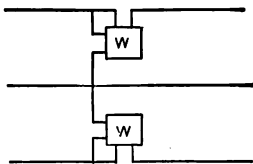

FIG. 355.—Power Measurement in a Three-phase Circuit.

$$\tan \theta = \sqrt{3} \frac{W_1 - W_2}{W_1 + W_2}.$$

In this formula  $W_1$  and  $W_2$  are the wattmeter readings. Having determined the tangent of the phase angle, the angle itself is determined from trigonometric tables. The cosine of this angle is the power factor. Curves may be plotted which will yield the power factor directly when values of  $W_1$  and  $W_2$  are known. A complete mathematical exposition of this method may be found in Frederick Bedell's *Direct and Alternating Current Testing*, page 232. A curve is given on page 232 showing the relations of  $W_1$  and  $W_2$ . The points on this curve are determined from the relation

$$\frac{W_1}{W_2} = \frac{\cos(\theta + 30^\circ)}{\cos(\theta - 30^\circ)}.$$

The larger reading is  $W_1$ , and will always be positive;  $W_2$  is the smaller reading and may be positive or negative. It





FIG. 356. — G. E. Single-phase Induction Wattmeter.



FIG. 357. — G. E. Single-phase Induction Wattmeter.

is well in measuring the power on a polyphase system to consider the circuit as made up from a number of single-phase circuits and to determine the sum of the energy consumed in each individual phase.

**Single-phase Integrating Wattmeter.**—The single-phase wattmeter, Figs. 356, 357, 358, has two windings, a series winding and a potential winding wound upon parts of the same magnetic circuit. The shunt winding is highly inductive and consists of a large number of turns of fine wire wound upon a laminated iron core. The circuit is highly

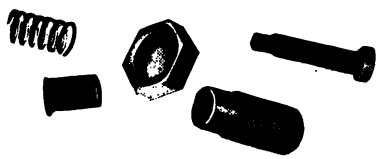

FIG. 358.—Jewel Bearing of Wattmeter.



FIG. 359.—Induction Wattmeter.

inductive and its current lags almost  $90^\circ$  behind its impressed e. m. f.

The series winding is practically non-inductive and consists of a few turns of heavy wire. On a non-inductive load the current in this winding will be in phase with the impressed e. m. f. The two magnetic fields of shunt and series winding will therefore be  $90^\circ$  apart, Fig. 360. Both of these magnetic fields act-

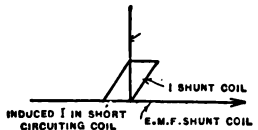

FIG. 360.—Vector Relation of Single-phase Meter E. M. F.'s.

ing on an aluminum disc produce a resultant field which is rotating, and this causes the disc to rotate. Eddy currents produced in the disc react and cause rotation, as the resultant field will vary with the product of the impressed e. m. f. and the current in the circuit, the torque of the disc will likewise vary. Magnets perform the same function in this meter as in the direct current Thomson Recording Wattmeter. In order that the meter may read power correctly, it is necessary that some compensation should be made for copper and iron losses in the shunt circuit which keeps the phase difference between the flux of the shunt circuit and the series circuit from being exactly  $90^\circ$ . One or two turns of wire are therefore placed on the projection of the pole of the shunt coil. These produce an induced field, which, acting with the shunt field, corrects for losses. This correction will vary if the power factor of the circuit varies to any extent, and adjustments should therefore be made for the power factor upon which the meter is intended to operate. Figure 358 shows a special form of spring bearing used in the Type I, G. E. meter. For complete descriptions of other types of alternating current meters see the comprehensive report of the meter committee of N. E. L. A., 1909. For friction curves of the Type I meter, see page 228.

**Experiment 156.** Calibrate a Type I single-phase meter on various inductive loads, and correct for power factor.

**Polyphase Integrating Wattmeters.** — Polyphase integrating wattmeters of the induction type consist of single-phase elements assembled on the same shaft. On a three-phase circuit when operating at unity power factor one winding of the meter will tend to lead, and the other to lag by  $30^\circ$ , the combined effect being neutral. In Fig. 361 let

$AC$  equal the potential winding of one element and  $BC$  the potential winding of the other element, the corresponding series windings being in line wires  $A$  and  $B$ . The current in phase  $A$  is displaced  $30^\circ$  from its potential  $AC$ , and in phase  $B$  the displacement is the same, although in the opposite direction. Each element on a three-phase meter at unity power factor load operates at about 86%, the cosine of  $30^\circ$ .

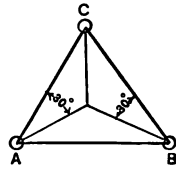

FIG. 361.—Relation of Current and Potential Vectors in a Polyphase Meter.

When the current in a three-phase circuit lags  $30^\circ$ , the condition is similar to that shown in Fig. 362, the meter operating at a power factor of 86%.

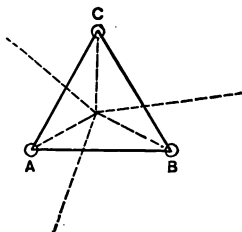

FIG. 362.—Polyphase Meter Vectors Current lagging  $30^\circ$ .

The current in phase  $B$  lags its respective potential  $60^\circ$ , while the current in phase  $A$  is in phase with its potential. One single-phase element operates at 50% power factor, while the other element operates at unity power factor. One element will therefore tend to run twice as fast as the other element. When the three-phase circuit lags  $60^\circ$ , or is operating at a

power factor of 50%, the current in phase  $B$  lags its potential  $90^\circ$ , operating at 0 power factor; while the current in phase  $A$  lags its potential  $30^\circ$ , operating at 86% power factor. Under these conditions one element has stopped and the other element is doing all of the work. When the current lags  $90^\circ$ , or zero power factor, one element has a power factor of  $-50\%$  and the other element has a power factor of  $+50\%$ . The meter element will not move under that condition, as one element will try to operate at one half speed in one direction while the

other element tends to operate at one half speed in the opposite direction.

### QUESTIONS

1. Define the henry and the farad, and explain how capacity and inductance affect an alternating current circuit.
2. What is a vector and how may it be used ?
3. Upon what principle does the G. E. Type I, single-phase meter operate ?
4. Show mathematically that a polyphase meter with two potential and two current elements indicates the total power in the circuit.
5. How is rotation produced in an alternating current wattmeter ?
6. Why does an indicating wattmeter indicate the true power in a circuit ?
7. What is meant by the term *resonance* ?
8. Why is the sine of an angle equal to the cosine of its complementary angle ?
9. Are capacity and inductance present in a direct current circuit, and if so, when do they affect the circuit ?
10. What method would you employ to obtain a set of instantaneous current voltage and power curves from an alternating current generator ?

## CHAPTER XV

### THE ALTERNATING CURRENT TRANSFORMER

THE alternating current transformer is a simple device, consisting of two coils, or a multiple of two, wound upon an iron core. An alternating e. m. f. is applied to the terminals of one coil, termed the primary, the potential being either raised or lowered across the secondary terminals, in proportion to the relative number of turns in both windings. By such an arrangement it is possible either to raise the potential of a few volts to several thousand volts or to lower the potential of several thousand volts to a few hundred volts. As the transformer is such a flexible piece of apparatus, it is possible to utilize it in transmitting high potential power, using a comparatively small wire, thus reducing to a minimum the amount of metal required. The transformer is undoubtedly the principal element in the alternating current system. By means of this device it is possible to reach over a much greater territory with alternating current distribution than can be done with direct current distribution, where the copper loss would be prohibitive.

**Theory of the Transformer.** — Suppose that alternating potential is placed upon the terminal of a coil of wire which is wound upon an iron core as in Fig. 363.

An alternating current will traverse the winding and set

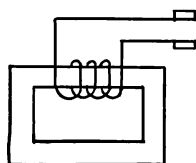

FIG. 363.— Experimental Study of Transformer.

up an alternating magnetic field in the iron core. This alternating flux will generate in the primary winding an alternating e. m. f., termed the e. m. f. of self-induction. Owing to the magnitude of this e. m. f., which lags  $90^\circ$

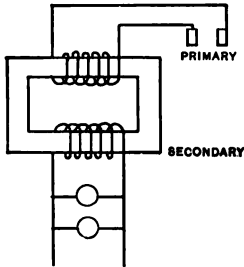

FIG. 364. — Simple Transformer.

behind the exciting e. m. f., the exciting current that passes through the winding will be small. This so-called magnetizing current is quite small in commercial transformers. It can be realized that this is a necessity of design, as the primary windings of transformers are connected continuously in service, and the energy which is lost in magnetizing the transformer must therefore be reduced to

a minimum. Suppose that a second winding is placed upon the same core as in Fig. 364. This may be termed the secondary winding. Suppose also that this winding is open-circuited at its terminals or is not connected to a load. As the alternating flux of the primary winding cuts the secondary winding, it generates an e. m. f. in this winding. This induced e. m. f. is  $90^\circ$  behind the flux of the primary winding, or  $180^\circ$  behind the primary e. m. f. It may therefore be termed a counter e. m. f. The relation between the primary e. m. f., the flux, and the secondary e. m. f. is shown graphically in Figs. 365, 366. If both primary and secondary coils have the same number of turns and there are no losses, the primary e. m. f. and the secondary e. m. f. would be equal, as there would be the same flux interlinked with each turn and

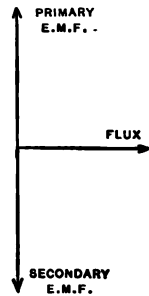

FIG. 365. — Relation of Transformer Vectors.

the rate of motion of the flux would be the same for both windings. Suppose that a resistance is connected across the secondary winding of a 1 to 1 transformer as in Figs. 364, 367, allowing a current to circulate through the secondary winding. If this resistance be a lamp bank, the lamps will light if the voltage relations are proper, although the current which will pass through the lamp circuit may be greater than the

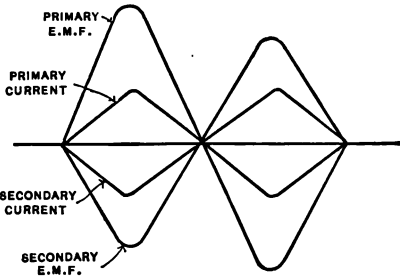

FIG. 366. — Relation of Instantaneous E. M. F.'s.

current which formerly passed through the primary winding. The question arises as to how this current can pass through the secondary winding in this case with a 1 to 1 transformer, if it is greater than formerly passed through the primary winding. It passes because the current circulating through the secondary winding produces a flux which

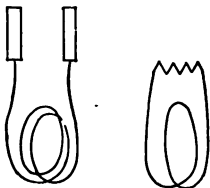

FIG. 367. — Load Connected to Transformer.

slightly counteracts the e.m.f. of self-induction of the primary winding. Since the ampere turns of the primary and the secondary winding are opposite, more current will enter the primary winding. If an ammeter, Fig. 368, be

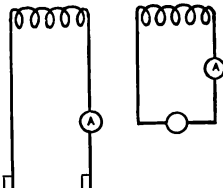

FIG. 368. — Load Connected to 1:1 Transformer.

placed in series with the primary circuit and one also in series with the secondary circuit, it will be noticed that when the load is placed upon the secondary circuit that the primary current increases. If



a 1 to 2 transformer is used, it will also be noticed that as the secondary current increases with increase in load the primary current will increase twice as much. So soon as this inductive effect is decreased, it allows more current to pass through the primary circuit. If the secondary circuit be completely short-circuited through zero resistance, a maximum of current will pass through the primary winding, this current being limited in magnitude only by the resistance of the primary winding. The fuses in the circuit will consequently blow. Most commercial lighting transformers used on the distributing system of lighting circuits are provided with four windings, two primary and two secondary. By this arrangement it is possible to produce various ratios of transformation. It sometimes happens in connecting up the secondary windings to produce a three-wire distribution, the primaries being fed from a single-phase circuit, that the terminals of the primary are not connected in the proper sequence, the end of one coil to the beginning of the other coil. When such a transformer connection is placed in operation, the primary fuses blow because the self-induction of the primary-winding has been neutralized by having the ampere turns of the primary windings opposed. It is obvious, therefore, that the transformer is perfectly automatic in its action and requires practically no supervision. As the current is being transformed, the transformer undergoes certain losses in energy termed resistance loss, eddy current loss, and hysteresis loss. As these losses have been treated of previously in connection with other apparatus, no further mention need be made of them here except to state that combined they represent a small total and thus allow high efficiency. For a 400-kw. Westinghouse transformer operating 6200 volts to 170 volts, that

is, having a ratio of 37 to 1, the losses and efficiency are as follows :

LOSS

Full load iron loss,	6,330 watts
Full load copper loss,	<u>4,356 watts</u>
Total,	10,686 watts

EFFICIENCY

100 % load,	97.8 %	(400-kw.)
75 % load,	96.5 %	
50 % load,	94.0 %	
25 % load,	91.0 %	
100 % load,	97.75 %	(800-kw., three such used
75 % load,	97.25 %	for a 2000-kw. rotary
50 % load,	96.50 %	converter)
25 % load,	93.50 %	

These are used in a single phase of a double delta 6-phase transformer as installed by the large lighting companies.

For details as to the mathematical calculation of these losses the reader is referred to the author's *Electric Railways*, Vol. II, Page 219. During the past few years much improvement has been made in the manner of designing transformers, as shown in Figs. 369, 370, the weight of the transformers per kilowatt being much reduced by obtaining better transformer iron and improving the magnetic circuits.



FIG. 369. — Modern method of building Transformers.

There is one other loss which has not been discussed, namely, the leakage of flux in the transformer. This depends upon the design of the transformer.

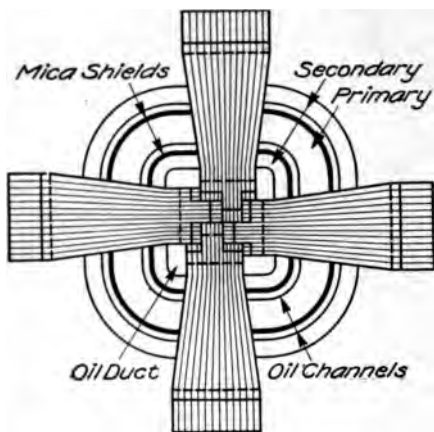

FIG. 370. — Cross section of Fig. 369.

shows a subway transformer, and Fig. 369 shows a modern shell type transformer.

**Experiment 157.** Connect the secondary winding of a constant potential transformer to a suitable source of potential, say the low tension side of a  $\frac{1}{2}$  kw. Type H-G. E. Co. transformer to a 120-volt alternating current source of potential. Place an ammeter in the circuit, and notice the low magnetizing current.

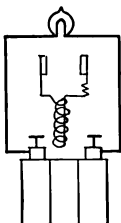

FIG. 372. — Showing Principle of Transformer.

**Experiment 158.** With the same set-up as in the previous experiment connect a lamp board to the other secondary winding, using one of the secondaries for the exciting circuit. Be sure that the high tension

In some cases, where the primary and secondary windings are separated, this cross flux may be used to secure automatic regulation for producing constant current or constant power. Figure 378

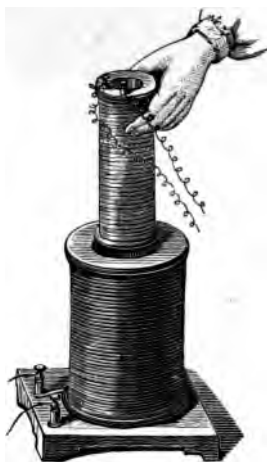

FIG. 371. — Queen & Co. Experimental Transformer.

Be sure that the high tension

windings are insulated or disconnected, as a dangerous high potential sufficient to kill will be generated in the high tension windings. Keep decreasing the resistance in the secondary circuit by turning on lamps, and notice that the primary current keeps increasing.

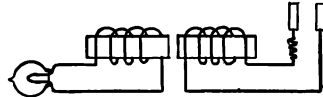

FIG. 373.—Reluctance of Transformer. Air Gap shown.

**Experiment 159.** Take a coil of No. 16 wire wound upon an iron core and pass an alternating current through the coil of about 10 amperes, having a suitable resistance in the circuit, Figs. 371, 372. Do not leave the coil on the circuit long, as it will heat up very quickly. Have another coil, arranged as in Fig. 372, consisting of a large number of turns into which the smaller coil will pass. To the larger coil connect a 16-candle-power lamp. Bring the smaller coil excited with alternating current into the larger coil, and notice that the lamp will light.

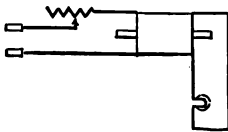

FIG. 374.—Study of Transformer.

**Experiment 160.** Take apart an old Type H transformer G. E. Co. and connect a lamp to the high tension winding on one coil, and excite through a suitable resistance the low tension winding on the other coil. The ratio of these windings is 20 to 1 for some transformers and 10 to 1 for other transformers. Take a 20 to 1 ratio. Bring one pair of coils near the other so that the ends of their cores touch, and notice that the lamp will light. Move coils a very small distance apart, Fig. 373, and notice the great diminution in candle power. When cores are in contact place a number of stampings around the outside of the coils connecting the two free ends of the cores, and notice that the candle power of the lamp will increase. Explain this phenomenon.

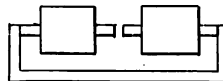

FIG. 375.—Varying Reluctance of Transformer.

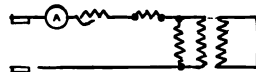

FIG. 376.—Measuring Copper Loss of Transformer.

**Experiment 161.** Place a wattmeter in circuit with the low tension winding of a 10 to 1 transformer, the other winding being open circuited, and notice the small wattmeter reading. This value represents the iron loss in the former. Use only one winding, as in Fig. 374, and vary resistance in circuit. Also vary magnetic circuit, as in Fig. 375.

**Experiment 162.** Place the wattmeter in the circuit as in the last experiment, and arrange an additional adjustable series resistance in the primary circuit. Place a short-circuiting strip across the secondary terminals, Fig. 376. We are considering the two low tension windings of a Type H transformer, one as primary and the other as secondary. Vary the resistance in

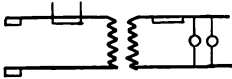

FIG. 377.—Efficiency.

the circuit and take a series of readings of the wattmeter. If an ammeter is also in circuit, the corresponding readings may be taken. These wattmeter readings will give the copper loss for this winding for various loads. Short-circuiting the free secondary winding eliminates the iron loss in the transformer, as it neutralizes its self-induction.

**Experiment 163.** Measure the efficiency of a transformer, Fig. 377, by placing a wattmeter in the primary circuit and a wattmeter in the secondary circuit, and by placing a variable load upon the secondary. A projecting wattmeter may be used for this purpose, arranging a short-circuiting switch for the current terminals in each circuit and a double-throw switch for potential.

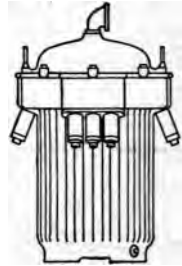

FIG. 378.—Manhole Transformer.

**Types of Transformers.** — Two types of transformers are commonly used by modern lighting companies, air-cooled

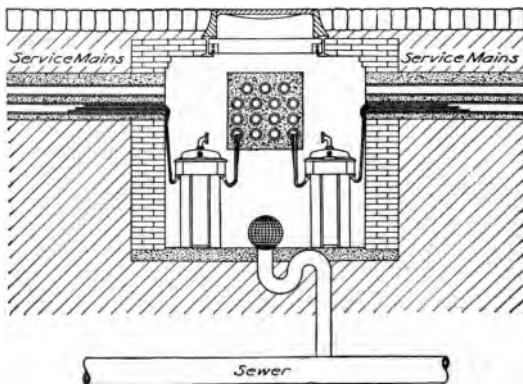

FIG. 379.—Manhole with Transformer installed.

transformers and oil-cooled transformers. The air-cooled transformers are used in station operation, and the oil-cooled transformers are used in the distribution system. The small oil-cooled transformers are used on pole lines, in manholes, as in

Figs. 378, 379, 380, or on the customer's premises. Subway transformers must be watertight, requiring special arrangements of leads. Where the transmission voltage is high, such as 80,000 volts, it is necessary to in-

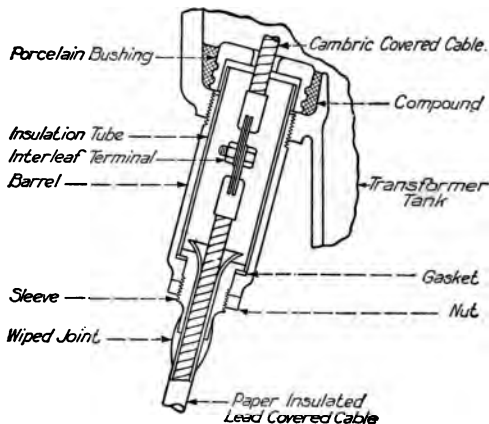

FIG. 380. — Waterproof Lugs for Subway Transformer.

insulate the transformer windings again with oil, and to keep the oil cool by means of pipes in it through which cold water circulates. With the ordinary air-cooled transformer, such as is used in central stations, air passes up through the transformer windings, this air being circulated by a motor-driven blower. Some companies use shunt motors for this purpose, but an induction motor is preferable, as a very large amount of dirt is drawn in by the blower from the floor of the station, this dirt depositing upon the commutators of the motors and causing the insulation between the windings to burn out. Service transformers are provided with two primary and two secondary coils, although it is becoming the practice to divide each secondary coil into two parts so that a balanced three-wire system can be

obtained, part of each secondary winding being in each leg of the circuit.

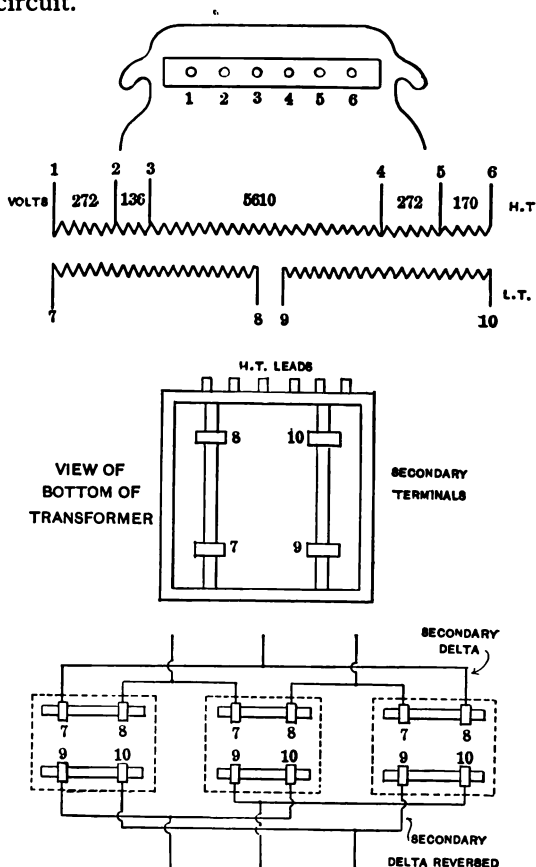

FIG. 381.—Station Transformer Connections, Six-phase.

**Station Transformers.**—The practice of central station companies at the present day in this country is to go in extensively for the use of three-phase transmission at 25 cycles, using a double delta connection of transformer

secondaries, Figs. 381, 382, producing six-phase, which is led to the slip rings of the converter. The converter has a larger capacity for six-phase than for three-phase, its capacity increasing with the number of phases. Where 60-cycle transmission is used, the motor generator system is preferred, as it has been found practically impossible to keep 60-cycle converters from flashing over their commutators. As the substations are sometimes located at a considerable distance from the main power house, resulting

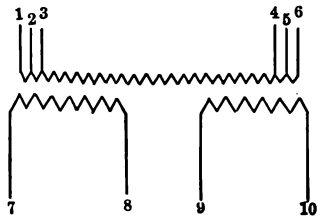
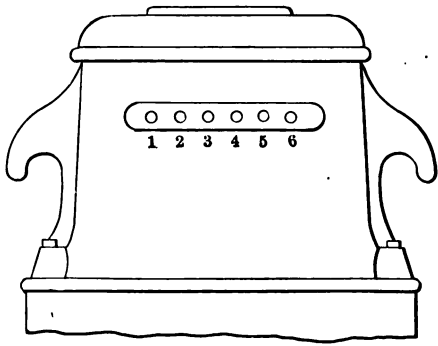
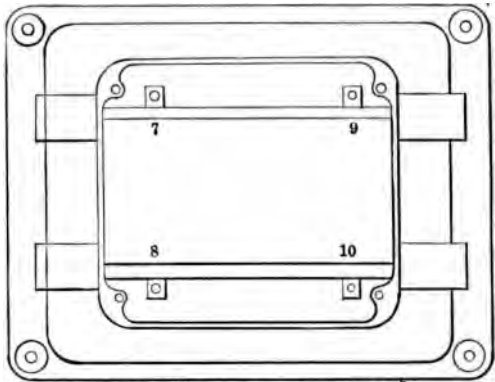

FIG. 382.—Station Transformer Connections, Six-phase.



in a considerable fall in potential on the alternating current feeders, it is necessary to provide the transformers with a number of taps in order to have a standard size which will be applicable to any part of the system. The diagrams, Fig. 382, show this method for a 6290-volt system, where the transformers have a ratio of 37 to 1, transforming the voltage at anywhere from 6450 to 5610 volts to 170 volts. In Fig. 382 it will be noticed that primary taps 1, 2, 3, 4, 5, 6 connect to the primary windings and produce between respective pairs a distribution of potential of 272, 136, 5610, 272, 170, volts. The secondary taps, 7, 8, 9, 10, coming from the bottom of the transformer, are connected in double delta, as shown in Fig. 382, the secondary taps being invariable. The location of the transformer primary and secondary leads as they leave the transformer are shown in Fig. 381. For a 200-kw. Westinghouse transformer and a 400-kw. transformer the taps and voltage relations are given in the following table, where the figures in the first column represent the voltages at various points on the system, and those in the second column give the taps to use to produce 170 volts alternating current.

In selecting a set of taps, the average voltage at the point should be taken. It is possible to raise or lower this 170 volts alternating current feeding the converters by means of the induction regulators. The converters with compensating poles or the converters with interpoles dispense with induction regulators. The 200-kw. transformer is arranged to give 186 volts instead of 170 volts in the following table. These transformers are air cooled. Their frames are permanently grounded so as to minimize danger in case the high tension windings should become grounded to the shell.

CONNECTIONS FOR 200-KW. TRANSFORMER

- With H. T. Voltage of 6450 connect to Terminals 1 & 6
- With H. T. Voltage of 6310 connect to Terminals 2 & 6
- With H. T. Voltage of 6045 connect to Terminals 1 & 5
- With H. T. Voltage of 6200 connect to Terminals 3 & 6
- With H. T. Voltage of 5910 connect to Terminals 2 & 5
- With H. T. Voltage of 5610 connect to Terminals 3 & 4
- With H. T. Voltage of 5720 connect to Terminals 2 & 4
- With H. T. Voltage of 5800 connect to Terminals 3 & 5

CONNECTIONS FOR 400-KW. TRANSFORMER

- With H. T. Voltage of 6450 connect to Terminals 1 & 6
- With H. T. Voltage of 6300 connect to Terminals 2 & 6
- With H. T. Voltage of 6195 connect to Terminals 1 & 5
- With H. T. Voltage of 6045 connect to Terminals 2 & 5
- With H. T. Voltage of 5985 connect to Terminals 1 & 4
- With H. T. Voltage of 5835 connect to Terminals 2 & 4
- With H. T. Voltage of 5600 connect to Terminals 3 & 4

With high tension connections as shown each half of low tension  
of 200-Kw. Transformer will deliver 186 volts  
of 400-Kw. Transformer will deliver 170 volts

Generally taps 1 and 5 are used with a 400-kw. transformer, using a primary voltage of 6290 and a secondary of 170 volts:  $6290/170 =$  ratio of 37/1. These transformers may be used as auto transformers if occasion requires. For instance, a voltage of 5600 volts could be fed into the transformer at taps 3 and 4, and 6450 volts could be taken out at 1 and 6. The induction regulators used in connection with these transformers have a high efficiency also, as, for example,

100 % load	93.6 %
75 % load	92.6
50 % load	90.5
25 % load	84.3

**Subway Transformers.** — Subway transformers, Figs. 378, 379, 380, are somewhat similar in construction to the regular transformers, except that they have to be circular in shape and water-tight. The entrance holes for the leads in the case of the transformer are provided with closely fitting bushings, Fig. 380, through which pass snug-fitting lugs, into which the leads of the transformer are sweated. The cover of the transformer is fastened in place with bolts passing through a rubber gasket. In all underground work it is necessary to take the same precautions that would be required in operating a submarine system, since the cables and transformers are frequently covered with water.

**Ratios of Type H Transformers.** — The small Type H lighting transformer may be used in so many different ways that a few details concerning its various possible ratios are pertinent. Many of these combinations are possible with other small transformers. The primary and secondary winding of these transformers have a ratio of either 10 to 1 or 20 to 1; the ratio of 10 to 1 will here be considered. In the low tension wind-

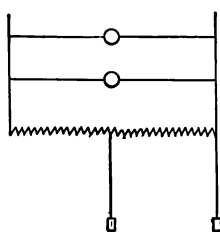

FIG. 383. — Type H Transformers 1 : 2 Ratio.

ings the transformer may be used as 1 : 2, 1 :  $\frac{1}{2}$ , 1 : 1, as shown in Figs. 383, 384, 385. By using one primary and one secondary, a ratio of 10 : 1 may be produced; by using one primary and two secondaries in series, a ratio of 20 : 1 may be produced. By using two primaries in series and one secondary, a ratio of 5 : 1 may result. By using two primaries in series and two secondaries in

series the transformer may be used as 1 : 2, 1 :  $\frac{1}{2}$ , 1 : 1, as shown in Figs. 383, 384, 385. By using one primary and one secondary, a ratio of 10 : 1 may be produced; by using one primary and two secondaries in series, a ratio of 20 : 1 may be produced. By using two primaries in series and one secondary, a ratio of 5 : 1 may result. By using two primaries in series and two secondaries in

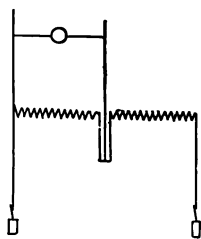

FIG. 384. — Type H Transformer 1 : 1 Ratio.

series, a ratio of 10 : 1 will result, or with the same primary connection but with the secondaries in parallel, a ratio of 20 : 1 results. By placing both primaries in parallel and both secondaries in parallel, a ratio of 10 : 1 results, and by placing the secondaries in series and the primaries in parallel, a ratio of 20 : 1 results. Usually both primary and secondary coils are used, a potential of 2240 volts being transformed to 112-224. Slightly higher voltages are frequently used.

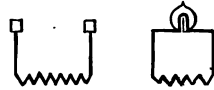

FIG. 385.—Ratio 1 : 1.

For details as to Scott's two-to three-phase connections, transformer types, structural features, transformer oils, heating of transformers, regulation, and losses, the reader is referred to the author's *Electric Railways*, Vol. II, where substation operation is discussed in detail.

**Experiment 164.** Connect a low tension winding of a Type H transformer to a 116-volt source of alternating current potential, and to the secondary terminals connect a 116-volt lamp showing 1 : 1 ratio.

**Experiment 165.** Connect both low tension terminals of the same transformer in series to a source of alternating current potential, and connect the lamp across one of the coils in shunt showing 1 :  $\frac{1}{2}$  ratio.

*Note.*—In experimenting with the low tension terminals of transformers, be sure to insulate the high tension terminals, as they will possess high potential which will be dangerous.

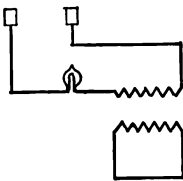

FIG. 386.—Neutralizing Self-induction of Transformer.

**Experiment 166.** Connect a 16-candle-power lamp in series with one coil of a Type H transformer, and an alternating current source of potential, and short-circuit the other winding, and the lamp will light, Fig. 386.

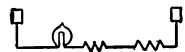

FIG. 387.—Transformer Secondaries in Series.

**Experiment 167.** Connect both secondary windings of a transformer in series with a 16-candle-power lamp and an alternating current source of potential, reversing

the connections of one of the secondaries, as in Fig. 388. Notice that the lamp will light.

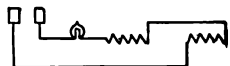

FIG. 388. — Transformer  
Secondaries connected in  
Opposition.

**Experiment 168.** Make the same set up, but reverse another one of the transformer connections, Fig. 387, and notice that the lamp will not light.

The instantaneous current and pressure curves of a transformer may be obtained by means of the contact maker and the telephone balancing circuit described on page 244. For the complete mathematical treatment of the transformer, the reader is referred to Steinmetz's *Alternating Current Phenomena*, pages 193 to 236, and for details as to design, to the *Alternating Current Transformer*, by Baum, and to *Transformer Design*, by Adams.

#### QUESTIONS

1. What is a transformer? How is it constructed, and how does it operate?
2. Show vector relation of e. m. f.'s in a transformer.
3. In what manner may the self-induction of the secondaries of a transformer be neutralized?
4. What ratios of transformation are possible with a Type H-G. E. Co.'s Transformer?
5. Name the principal methods of cooling transformers.
6. What method could be employed to determine the beginning and the ends of the secondary coils of a transformer so as to know the proper series connection?
7. Draw a vector diagram to show how six-phase transformation may be obtained from three-phase transformers.
8. Draw diagram of circuits to show when there would be attraction and repulsion between transformer windings.
9. How may the core loss, the copper loss, and the efficiency of a transformer be measured?
10. Is the efficiency of a transformer high or low, compared with other pieces of electrical apparatus?

## CHAPTER XVI

### THE INDUCTION MOTOR

**Theory.**—Two phenomena occur when two coils carrying a. c. current are brought near each other, one of the coils having a resistance shunted across it, and the other coil being the exciting circuit. One of these phenomena is a transformation of pressures, the other is a mechanical reaction or repulsion between the coils. In the ordinary transformer the coils are fixed in position and the potential transformation feature is utilized, while in the induction motor, Fig. 389, the coils are movable, the mechanical reaction between them being utilized in addition to the potential transformation feature; indeed, the latter does not play quite so important a part as the former. The operation of the induction motor may best be illustrated by considering the squirrel-cage induction motor. This motor is very simple in construction, consisting of a circular core containing slots, in which are placed the magnetizing conductors or *stator* winding. This winding is symmetrical and is supplied usually with out-of-phase cur-



FIG. 389. — Induction Motor.

rents, two or three-phase, producing a rotating field. The moving element, or *rotor*, consists of a number of laminations assembled on a shaft containing holes or slots in the periphery through which are passed copper rods, these rods being short-circuited upon each other at each end. When the motor is stalled so that rotation cannot occur, the alternating current passes into the stator winding, inducing low voltage currents of large capacity in the short-circuited secondary winding of the rotor. This feature is similar to the operation of ordinary step-down transformers. If the brake is removed, repulsion between the rotor and the stator causes the rotor to turn and as the out-of-phase currents produce a shifting or rotating field—the north pole traveling around the rotor—the repulsion of the rotor is continued. The rotor speed when the machine is unloaded is slightly less than the speed of the rotating field, this difference in speed being termed *slip*. When a load is placed upon the motor, this slip increases, and the slip in turn increases the induced current in the rotor winding and thus increases the torque. This process will continue up to a certain point, beyond which the limit of stability of the machine is exceeded, and the machine will come quickly to rest.

**Experiment 169.** Dismantle a small induction motor, and excite the three-phase winding from a three-phase circuit, placing a resistance in series with each leg of the circuit, Fig. 390, so as to limit the current input to about 4 amperes. Support the motor on blocks in a vertical position, resting on the lower bearing as is shown in the horizontal projection. Have convenient a hollow copper sphere, Fig. 391, such as is used as a float in reservoirs. This copper sphere should be either suspended on a string or supported on a  $\frac{1}{4}$ " rod so that it can rotate between the fingers when held loosely. Excite the three-

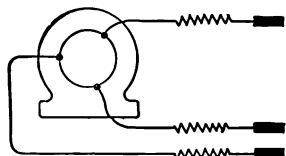

FIG. 390.—Experimental Study of Induction Motor.

phase circuit of the motor, and suspend the copper sphere inside of the frame. Rotation will immediately occur, the sphere revolving at a high speed. Change over any two of the three leads of the motor and notice that the direction of rotation of the sphere changes. The copper sphere in this experiment corresponds in an elementary way to the rotor of the induction motor, out-of-phase currents being induced in the sphere and producing a rotating field which follows the rotating field of the stator winding.



FIG. 391. — Copper Sphere.

**Experiment 170.** Use only one of the phases excited as before and, in place of the copper sphere, bring inside of the motor frame a coil of fine wire of many turns with an iron core so

that the single-phase alternating current in the rotor winding will induce an e. m. f. in the stator winding. Measure this e. m. f. with a voltmeter, a projecting voltmeter if a lantern is being used, Fig. 392. This simple experiment illustrates the transformer action taking place in the machine.

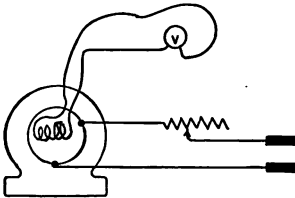

FIG. 392. — Transformer Feature of Induction Motor Shown.

direct current from a 116-volt source of potential, Fig. 393, a suitable resistance being placed in circuit. Move around in the winding the north pole of a compass needle, and notice that separate poles exist — say four poles, two north and two south. Excite another phase in the same manner and notice that four more poles are

**Experiment 171.** Excite one of the phases of a three-phase machine with

direct current from a 116-volt source of potential, Fig. 393, a suitable resistance being placed in circuit. Move around in the winding the north pole of a compass needle, and notice that separate poles exist — say four poles, two north and two south. Excite another phase in the same manner and notice that four more poles are produced, then excite the third phase and notice that four more poles are produced. Each of the phases produces the same number of poles, these being symmetrically distributed over the periphery of the stator. Thus, at a given instant of time, when supplied with alternating current, four main poles will be produced, each one made up of sets of three coils, and each of these having the same polarity as in Fig. 394. At the next instant of time — looking clockwise — the first one of all of the sets of south poles will become a north pole, and the

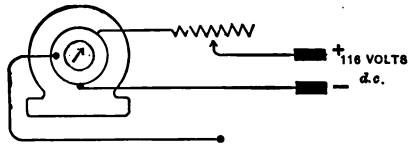

FIG. 393. — Poles of Induction Motor Shown.



first one of each of the sets of north poles will become south, as in Fig. 394. In other words, the relative separate poles exist, but there

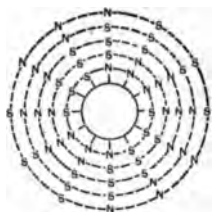

FIG. 394. — Progression of Poles of Induction Motor with Alternating Current.

is a continual progression around the stator. In a three-phase circuit the phases are 120 degrees apart, a complete rotation of the field depending upon the number of pairs of poles. Thus, a four-pole induction motor operated from a two-pole generator will rotate only half as fast as the generator.

#### Operation of an Induction Motor. —

An induction motor is essentially a constant speed machine. Its speed may be varied by varying the number of poles, a method now being used on small machines made by the General Electric Company and the Westinghouse Electric Manufacturing Company. To set up an induction motor and to operate it is only necessary (for small machines) to connect the phase terminals directly to the source of supply. With a two-phase machine, Fig. 395, two of the phases may be connected, forming a two-phase three-wire system wired up to the transformers, the transformers being connected in the same manner. Care should be taken to fuse the neutral wire heavier than either side of the system, as the load on the neutral leg is heavier than on either outside legs.

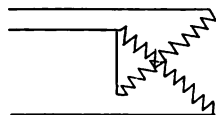

FIG. 395. — Two-phase Induction Motor.

In starting machines of five horse power and more, it is customary to have a starting resistance either internally or externally connected. This high resistance gives a high starting torque, and the elimination of this resistance at the higher speeds gives a high efficiency.

A three-phase induction motor may be operated from a single-phase circuit, Fig. 396, by means of various phase-splitting devices. A condenser compensator, consisting

of a combination of capacity and inductance or a combination of choke and resistance coils, produces the desired effect.

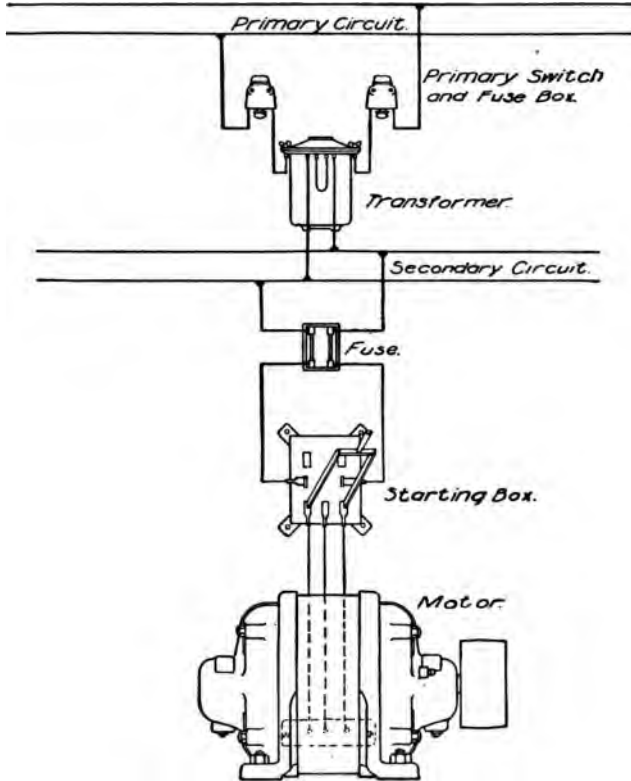

FIG. 396. — Three-phase Induction Motor operated from Single-phase Circuit.

In certain classes of work the induction motor is preferable to other types of motor. In central station work for the driving of blowers, Fig. 397, they are used almost exclusively, although there are some cases in which shunt

motors are used for this purpose.' Induction motors are preferable to shunt motors for blower service, because the blowers are continually drawing air in through the motor,



FIG. 397. — Induction Motor operating a Blower.

which deposits the dirt on the windings of the motor and also on the blades of the blower. It has been remarked that "a blower is the dirtiest piece of apparatus to clean in existence." Where a shunt motor is employed, this dirt accumulates on the commutator, and the commutator burns out, necessitating frequent repairs. The small induction motor is used extensively in the outlying districts of lighting companies when alternating current is employed for distribution. The two-phase motor is used mostly for this work. Its advantage lies in the facts that a combined lighting and power system may be operated from the same

set of mains, and that where there is a possibility of having lighting customers alone, only one phase of the two-phase system is employed. With power circuits two transformers are installed on the pole line near the customer's premises, and the low tension sides of the step-down transformer are placed in series, producing a three-wire system of 240 volts between each phase, and  $240 \times \sqrt{2} = 338$  volts across the outside legs of the circuit.

**Changing Direction of Rotation.**—The direction of rotation of a three-phase induction motor may be changed by changing over any two of the phases. This, as has been said, causes the rotating field to rotate in the opposite direction, the drag on the conductors of the rotor pulling it around.

In starting an induction motor of large capacity, 100 kw. for instance, it is common to have two sets of taps leading from a step-down transformer to a double-throw switch. One set of taps supplies normal voltage, and the other type supplies  $\frac{1}{2}$  or  $\frac{1}{3}$  normal voltage. At starting, the switch is thrown on the low voltage side, and after the machine has attained speed, the switch is closed in the opposite direction, putting normal voltage on the machine.

**Experiment 172.** Change over terminals of induction motor, causing the direction of rotation to change.

**Care of Induction Motors.**—Owing to the simplicity of the induction motor, its lack of brushes, brush holders, commutators, and slip rings, operators are likely to neglect this piece of apparatus. Dirt and oil are likely to collect in the windings, in which event they become short-circuited and burn out. This is all the more likely to occur, as induction motors are usually mounted in places somewhat inaccessible, owing to their simplicity. Induction motors should be cleaned and inspected at regular intervals, like

other station apparatus, and should receive their proportionate amount of care.

### QUESTIONS

1. Compare the operating features of an induction motor and a transformer.
2. How is rotation caused in an induction motor?
3. Why does changing over any two pair of leads of a three-phase induction motor cause the direction of rotation to change?
4. Considering the induction motor as similar to a transformer in magnetic features, how would you measure the losses of the motor?
5. Why is it necessary to use a starting device for large capacity induction motors?
6. Why is an induction motor easier to maintain than a direct current motor?
7. Why is it necessary to fuse the neutral leg of an induction motor, two-phase three-wire, heavier than either outside wire?
8. Why is it that a  $\frac{1}{2}$  horse-power induction motor will not be injured if you place a load upon it sufficient to bring it to a standstill?

## CHAPTER XVII

### THE ROTARY CONVERTER

THE rotary converter is a machine used for converting direct current into alternating current, or alternating current into direct current. It is most frequently used to convert alternating current into direct current. The converter possesses an armature surrounded by a field winding. The armature possesses a single winding, having a commutator connected at one end, and slip rings at the other end. A shunt motor may readily be made into a rotary converter by mounting slip rings either over part of the commutator, if the commutator is long, or mounting slip rings on the other side of the armature from the commutator end, connecting the slip rings to the winding at equidistant points. For a three-phase rotary the taps should be connected at three points  $120^\circ$  apart. Converters may be single-phase, three-phase, six-phase, twelve-phase, etc. Three-phase and six-phase machines are used most frequently, the latter often being preferred, owing to its increased capacity. An interesting feature in connection with a converter is that, while operating, converting alternating to direct current, it can also be belted to a load and made to deliver mechanical power at the same time.

**E. M. F. Relations.** — Owing to the fact that there is but one winding on the ordinary converter and that also there is but one field winding, barring booster converters, the direct current voltage and the alternating bear a definite relation to each other. It is possible to vary this ratio slightly by varying the field excitation, sufficient, however,

for load regulation. Varying the field excitation changes the power factor. In the new type of interpole converters and booster converters the ratio can be changed over quite a large range. This feature will be discussed later. The coefficients by which the voltage between the direct current brushes must be multiplied in order to obtain the effective alternating current voltage between adjacent slip rings or rings of the same phase are as follows :

2 rings	0.707
3 rings	0.612
4 rings	0.500
6 rings	0.354

Consider a two-pole converter armature, Fig. 398, containing two slip rings connected to taps 180° apart. Between these

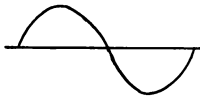

FIG. 398.—Converter Armature Connections.

two slip rings there will be produced a single phase e. m. f., Fig. 398, whose maximum value will equal that of the e. m. f. existing between the direct current brushes, assuming a two-pole machine.

The relation between the maximum value of an alternating e. m. f. and its effective value is given by the expression  $1/\sqrt{2}$ . The maximum value of  $E_m$ , which is the same as the direct e. m. f. divided by the square root of 2 or  $E_m/\sqrt{2}$ , equals the effective value, or

$$E = E_m/\sqrt{2}.$$

Instead of dividing  $E_m$  by  $\sqrt{2}$ , the voltage  $E_m$  may be multiplied by the reciprocal of this quantity, or  $1/\sqrt{2}$ , or .707.  $E_m$  may be considered in this case as equal to the direct e. m. f. and  $E$  as corresponding to the single-phase alternating e. m. f. This method of reasoning may be applied

to a three-phase e. m. f., except that in this case the figure assumes an equilateral triangle, and the relation between one of the sides and the diameter is taken as  $1/\sqrt{3}$ .

**Problem.** Deduce factor 0.612 for a three-phase machine.

**Experiment 173.** Take a three-phase converter and measure with an alternating current voltmeter the voltage between successive slip rings and between the direct current brushes. Operate the converter from the direct current side with a field rheostat in the circuit. Vary the field excitation which will change speed of converter or its frequency and notice inappreciable change in the alternating e. m. f.

As such features of the rotary converter as magnetic circuits and tests for trouble are similar to those of a shunt motor, it is unnecessary to describe them here; instead, we may discuss operating features and recent developments in converter manufacture.

**Methods of Starting Converters.** — Three methods are in common use for starting converters, although this number could be increased by modification of the primary methods. The converter may be started from the direct current side as a shunt motor; it may be started from low potential taps on the transformer connected to the alternating current side, the field circuit being open; or it may be started by means of an induction motor mounted upon one end of the converter shaft. Each of these methods has its advantages and disadvantages, but as all of these methods are used extensively, it is obvious that the disadvantages are theoretical rather than concerned with operation.

**Starting from the Direct Current Side.** — With this method the converter is started from the direct current side like a shunt motor, and the same precautions are taken as would be observed in starting a shunt motor of the *same capacity* as the converter. This method is used almost exclusively by lighting companies, as it requires a small amount of



apparatus and produces the least disturbance in the system. Furthermore, as a battery floats on many of the large systems, there is no necessity for the saving in time of starting that could be accomplished by other methods. To start, synchronize, and place full load upon a 1500-kw. machine, requires with a good operator about 90 seconds. Some companies prefer to start their converters from a separate motor generator set. When being started in this way, the converters do not accelerate so rapidly as when they are started from the direct current bus. They are then synchronized and connected to the alternating current side of the system. This method gives a flexible control, and the converter can run idly on the alternating current side as a synchronous motor until ready to be used, when it is connected to the direct current bus. Care must be taken in connecting the machine to the direct current bus to see that its voltage is slightly higher than the bus. If lower, there might be a tendency to motorize, the reverse current relays tripping the machine from the circuit.

An interesting case was called to the attention of the writer in which the main power house was disabled, and it was necessary in order to receive power at a certain substation to send it from a small power station at a distance. The substation contained no storage battery, and the alternating current pressure when it arrived at the station was quite low. Not having direct current pressure on the bus, the operator connected the converter directly to the alternating current side, supplying low voltage to the alternating current, slip rings of the converter opening the field circuit. When the converter had reached synchronism, the field circuit was closed. This gave a direct current voltage which was lower than normal but which provided some low voltage current to the immediate territory. When the

trouble at the main power house was cleared the pressure on the alternating current mains was raised, and the direct current pressure became normal.

**Starting by Means of Induction Motor.** — This method is used extensively by the Westinghouse Electric Manufacturing Company. Upon the shaft of the converter is mounted the rotor of an induction motor, which is started from the main switchboard. The stator is mounted over the rotor suspended on a frame on the side of the converter. When the converter has been brought up to speed, it is synchronized. This method has the advantage that it requires a small amount of switch gear and less throwing of switches in starting than in the motor generator method, but its saving in time is offset by the lack of speed regulation necessary for rapid synchronizing where there is any voltage fluctuation. A good operator, however, with this method can synchronize and start a 1500-kw. converter in about two minutes. If much fluctuation of voltage exists, the synchronizing becomes more difficult. An experienced operator endeavors to "catch" the machine on the way up. If the voltage on the system is below 15%, it may be impossible to start the converter, since the torque of an induction motor varies as the square of the voltage. The principal advantage of this method is the increased factor of reliability, owing to the fact that each converter has its individual starting motor. If desirable, the converter can be arranged to start from the direct current side also, which can be used in case of emergency.

**Starting from the Alternating Current Side.** — This is by far the simplest and quickest way of starting a converter. It is used extensively by railway companies where in emergency it is desirable to start a machine in the shortest possible time. The writer has started a 1000-kw. machine,

synchronized it, and had full load upon it, in 28 seconds. The operation was regularly accomplished by the operators in the station in 33 seconds.

The transformers supplying the alternating current side of the converter are equipped with a series of low potential taps giving  $\frac{1}{3}$  and  $\frac{2}{3}$  normal voltage. These various potentials may be supplied directly to the alternating current slip rings by means of two triple-pole, double-throw switches for a three-phase machine. At starting, the field circuit of the rotary is opened at about 6 points by a break-up switch, the double-pole switches are both thrown up, connecting the converter directly as an induction motor to the first set of low potential taps, and the rotary speed quickly rises to synchronism. When the operator thinks that synchronous speed has been reached, the field switch is closed, and the direct current armature voltage is noted. If the voltmeter tends to deflect in the wrong direction, the field switch is opened and closed in the opposite direction, in which case a pole will be slipped and the voltmeter will indicate properly. Sometimes the operator will continue closing and opening the field switch in one direction until the voltmeter indicates in the right direction. When the voltmeter indicates properly, showing synchronism, both double-throw starting switches are thrown down, raising the potential on the direct current side. This method owes its rapidity to the entire elimination of synchronizing, the converter operating as an induction motor up to synchronism, and operating as a synchronous motor when the field circuit is closed. It is necessary to use break-up field switches, as, in starting, high potentials are generated in the field coils, owing to the transformer action of the armature turns, through which alternating current passes. At starting, a potential as high as 2000 volts across each indi-

vidual field coil is common. As has been said, the great advantage of this method of starting is its rapidity and simplicity, qualities highly desirable in time of emergency. Its disadvantage consists in the fact that at starting the armature takes from the system a heavy inductive load, which is likely to affect the regulation of the system. This load is frequently as high as the full load of the converter. An inductive load takes magnetism from the system, whereas the field coils of machines operating may be adjusted to supply magnetism to the system. The writer remembers a case in which a 1500-kw. converter, taking a normal starting current from the direct current side of  $\frac{1}{4}$  full load value, was started from the alternating current side by being thrown directly upon the transformers. The starting current was 3 times full load value, or 12 times that which was necessary to start from the direct current side. These machines were constructed for good synchronous operation, in which case their self-induction was reduced to a minimum. Converters intended to start from the alternating current side must have slightly higher self-induction in order to limit the starting current. These converters are further provided with series reactance coils, which, though installed for other purposes, — as, for instance, to allow slightly unbalanced potential to be placed in parallel, — serve to limit the starting current. When the self-induction of a converter armature is large, it acts in a sluggish manner on the circuit while operating, and does not permit the converter to respond quickly to sudden changes in frequency of the circuit, thus causing a tendency to *hunt*.

**The Hunting of a Converter.** — The hunting of a converter is a term applied to the state of a converter armature which has become slightly out of phase with the

generator; in attempting to get in phase it is carried beyond the neutral position, becoming out of phase again. This process of swinging back and forth across the neutral point is termed hunting. Where the hunting becomes excessive, the machine may be thrown out of step. When a converter armature is operating at synchronous speed, we can consider the armature to have definite poles north and south, being adjacent to the poles of the field winding. When hunting occurs, the poles of the armature tend to shoot across the field pole faces, the north poles of the armature tending to take the place of its south poles. In order to minimize the effect of hunting, *pole dampers* are placed on the poles of the converters. These pole dampers are copper grids, rectangular in shape, containing crossbars sunk into the pole faces. They act as the short-circuited secondary of a transformer to the converter armature, neutralizing the self-induction of the armature. They also have eddy currents induced in them when the armature flux tends to shoot across the pole face, and they therefore offer a resistance to the swinging of the armature. They offer no resistance to the normal operation of the armature, except when it tends to go out of synchronism.

**Experiment 174.** Open the field circuit of a small converter, 1 kw., and connect the alternating current slip rings of the machine to another converter. The second converter should be connected by means of a starting box to a direct current source of potential. Start this latter machine rather quickly, as the starting current will be excessive and the starting box may become quite hot. The 1-kw. machine, being started from the alternating current side, will be operating as an induction motor. When this machine begins to operate, the starting box handle of the first machine should be turned on the balance of its way rather quickly until all of the starting resistance is eliminated. The second machine will be operating as an induction motor and its field circuit may be closed, the

converter becoming a synchronous motor ready for its load. When a lamp load is placed upon the second machine, it will be operating as a converter. This method of starting is used in substation operation where a converter is being started for the first time, and it is desirable to dry out the circuits. The main generator is connected to a spare bus, and feeders connect it directly to the substation transformers passing through a spare station bus. The converter and generator are electrically connected together through the alternating current side of the converter, and the main generator is slowly started into operation, the converter slowly following in speed operation. The field circuit of the converter is opened. As the frequency of the generator is low, the e. m. f. generated is low.

**Synchronizing.** — Synchronizing is the process of adjusting the frequency, the magnitude, and the phase displacement of two e. m. f.'s so that their wave shapes will coincide; accordingly, if the machines are generator and converter, the wave shapes of e. m. f. of the two machines will pass through their maximum and zero values at the same time intervals. The general practice when synchronizing is first to get the e. m. f.'s of the two machines adjusted so that they will have the same effective values. The speeds are next adjusted so that the frequencies of the two waves are the same; and then by means of lamps, synchronoscopes, voltmeters, etc., the waves are brought together until there is no phase displacement. The two machines are then coupled in parallel. When synchronizing with lamps, they may be connected one in each phase, as in Fig. 399, a short-circuiting switch being arranged to be closed at the instant of synchronism. When the two e. m. f.'s are in synchronism, there will be no interchange of current and the lamps will not light. In practice the lamps are connected in a secondary circuit, as Fig. 400, consisting

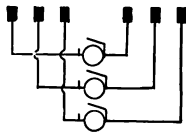

FIG. 399. — Synchronizing with Lamps.

of the secondaries of two transformers. The transformer secondaries may be connected in opposition, in which case

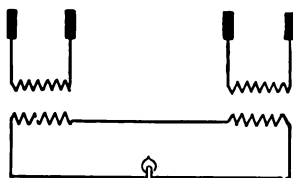

FIG. 400. — Synchronizing with Lamp connected to Transformers.

the lamps will be dark at synchronous speed, or the windings may be connected to assist each other at synchronism, resulting in a bright lamp. Synchronizing with a dark lamp is the more common method. Tungsten lamps are preferable to carbon lamps for synchronizing, as they remain luminous at a much lower voltage, a carbon lamp yielding no illumination at 30 volts, whereas a tungsten lamp filament is just visible at about 10 volts. With the tungsten lamp the changes in luminosity due to change in e. m. f. are more rapid than with a carbon lamp, owing to the former lamp having a positive temperature coefficient.

**Synchronizing with a Synchronoscope.** — In large central stations it is customary to operate the oil switch motor or the solenoid of the magnet type of switch from a 120-volt source of potential. This potential may be supplied from a small storage battery or from the regular service bus. The advantage of the separate source of potential is that in case of trouble the operator can readily manipulate his switches irrespective of load conditions. To operate an oil switch, open or closed, requires an interval of about  $\frac{4}{10}$  of a second. The operation of opening or closing the switch is performed by an operator who closes a small switch on the switchboard panel. It is evident, therefore, that if the operator is using the synchronoscope to synchronize, he must close the battery switch when the pointer of the synchronoscope is moving to the zero, and when for its particular rate of travel the pointer is away

from the zero such a distance that it will reach zero in  $\frac{4}{10}$  of a second. It is better to connect the rotary to the circuit when it is going into phase instead of going slightly out of phase, for in one case the inertia of the armature assists and in the other case it retards. Too little attention is given to the question of inertia in operation. In starting a large machine into operation we must consider its inertia and not eliminate the starting resistance too rapidly. If the synchronoscope pointer is moving too rapidly over the dial, and the oil switch is closed at the instant of synchronism, the inertia of the armature will tend to throw the machine out of synchronism, the machine remaining in step, but sparking rather violently.

**Synchronizing with a Voltmeter.** — A direct current voltmeter may be used to advantage to synchronize machines by connecting it in the circuit in place of a synchronoscope. The voltmeter needle will rise from zero and fall again repeatedly as the machine is approaching synchronism, the motion of the pointer becoming slower and slower. When the needle is falling to zero very slowly, the operator closes the oil switch as the pointer has almost reached zero. This is a simple method and quite easy to manipulate.

**Synchronizing with Frequency Indicator.** — With this method the voltage of both machines is adjusted until it is almost the same in each, and then the frequencies of both machines are made equal. The operator next places a lamp in the circuit and can usually get his machine in circuit on the first cycle of intensities on the lamp.

**Experiment 175.** — Make a set-up between two small 1-kw. converters, so that they can be started from the direct current side with resistance in each of the field circuits. Connect both of the three-phase slip rings of the machine through lamps and arrange a short-circuiting switch so that when closed each of the individual lamps will be short-circuited (Fig. 401). The purpose of the lamps, as has been said, is to indicate



such an interchange of current as is taking place. If two machines

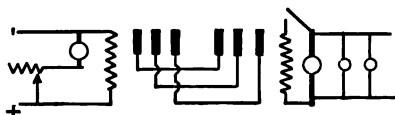

FIG. 401.—Synchronizing Two Converters.

operating at the same synchronous speed were placed together with considerable phase displacement, there would be a heavy interchange of current due to the difference in their instantaneous e. m. f.'s. This is represented clearly by Fig. 402 where, if the switch were closed when the values of the two curves were at time interval *A*, one machine would be generating 120 volts and the other machine would be zero potential, 120 having been selected for the maximum value of the curve. In continuing the experiment,

start both machines and notice with short-circuiting switch open that the lamps rise and fall in candle power. When at a maximum of candle power, the machines have their greatest phase difference in instantaneous potentials, being, in Fig. 402,  $90^\circ$  apart. If the switch were closed at this instant, the interchange of current would be at its maximum. Sometimes in synchronizing, the lamps will not go entirely out but start to increase in candle power. A good operator never closes the short-circuiting switch the first time that the lamps pass through zero candle power; instead, he waits until two or three fluctuations have occurred in order that he may judge how much out of step his machines are. Then he closes the switch when he is sure that the light is going to pass through zero candle power and when it has almost reached zero. With the set-up described above study all of the features of synchronizing.

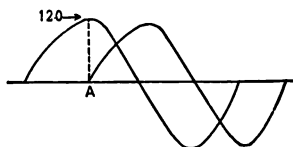

FIG. 402.—E. M. F. Relations when Machines are out of Phase.

start both machines and notice with short-circuiting switch open that the lamps rise and fall in candle power. When at a maximum of candle power, the machines have their greatest phase difference in instantaneous potentials, being, in Fig. 402,  $90^\circ$  apart. If the switch were closed at this instant, the interchange of current would be at its maximum. Sometimes in synchronizing, the lamps will not go entirely out but start to increase in candle power. A good operator never closes the short-circuiting switch the first time that the lamps pass through zero candle power; instead, he waits until two or three fluctuations have occurred in order that he may judge how much out of step his machines are. Then he closes the switch when he is sure that the light is going to pass through zero candle power and when it has almost reached zero. With the set-up described above study all of the features of synchronizing.

**Crossed Phases.**—In order that two machines may be synchronized, it is necessary that all of the similar phases of the two machines should pass through their zero and maximum values at similar time intervals. Their respective rotating fields should each move in the same direction and at the same rate of speed. If two of the phases of one of the machines are crossed, as in Fig. 403, and an attempt is

made to synchronize, it will be impossible to get all of the phases of one machine to pass through their maximum values simultaneously with the phases of the other machine.

The alternating e. m. f. of one machine will be tending to rotate the other machine in the contrary direction to which the direct current service is driving it. The two rotating fields in

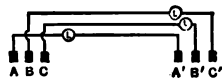

FIG. 403. — Crossed Phases.

one machine will therefore be traveling in opposite directions. Try this experiment, connecting phase *A* to phase *A'*, phase *B* to phase *C'*, and phase *C* to phase *B'*, as in Fig. 403. Start up both machines with the lamps in circuit, and attempt to synchronize. When the machines are traveling at speeds almost synchronous, it will be noticed that first one lamp will reach a maximum candle power, then a second lamp, and then a third. If the field rheostat is carefully adjusted, the lamps will light up first in 1-2-3 order and then, with further adjustment, in 1-3-2 order. This experiment is both attractive and instructive. Make other combinations of the phases, keeping the original crossed connection, and notice that the machines can be placed in phase.

**Meaning of Unity Power Factor.** — For a given output in a converter, there is a minimum current input which occurs

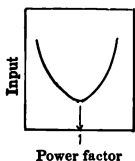
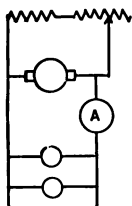
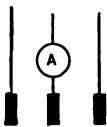

FIG. 404. — Unity Power Factor of Converters.

when the converter is operating at unity power factor. Above or below this point, the input of the converter is greater than necessary for the given output, and the excess current unnecessarily heats the armature. This fact is illustrated in Fig. 404. The adjustment to unity power factor is usually made by adjusting the field circuit which changes the self-induction of the system.

The adjustment to unity power factor is usually made by adjusting the field circuit which changes the self-induction of the system.

By adding or taking away magnetism, a resonant condition is reached, in which the fixed capacity of the cables of the system is neutralized. At this point unity power factor is attained. This feature is of much importance, and all good operators endeavor to run their machines at unity power factor.



a. c. volts  $\times$  a. c. amperes  $\times$  power factor = true watts.

$EI \cos \theta = W$ , where  $\theta$  = angle of phase displacement between the e. m. f. and the current.

**Experiment 176.** Connect up a converter so that it will operate from a 3-phase source of supply, converting it to direct current. Place an ammeter in one of the phases and place a load upon the direct current side of the machine, Fig. 405. Note the reading of the direct current ammeter placed in series with the load. Vary the field excitation of the converter with the field rheostat, and notice that the direct current load remains constant but that the alternating current load varies, too much excitation or too little excitation causing an increase above the minimum value of the alternating current input.

**Converters operating in Parallel.**—Two converters of the same size operating in parallel will tend to divide the load proportionally, provided that they are both set for unity power factor. There are several things which affect the distribution of load between two such machines, namely, the temperature of the field coils, the adjustment of the field rheostats, and the condition of the brushes. When a converter is first placed in service on the bus after being idle for a day or two, the resistance of the field coils is that due to the temperature of the room. After the machine has been operating for a few hours the temperature of the windings increases, and this increases the field resistance

and decreases the field excitation, making necessary a readjustment of the field rheostat. This change in resistance may be noted by the operator from the fact that the other converter will gradually take most of the load. Adjustment of the field rheostats will distribute the load at will between the machines in a station and between separate stations. This adjustment alters the power factor, and varies slightly the e. m. f. of the converter. The writer, when operating at night two 1500-kw. converters, has observed the following interesting fact. When the load would fall to such a point that it was felt that one machine was sufficient, one of the converters was disconnected from the bus. Upon affecting this disconnection it was always noticed that the previous load was not now carried by the single machine, but that part of the load seemed to be distributed to other stations, although no adjustment of the field rheostat of the machine remaining in service had occurred. The remaining load was always about two-thirds of the original load. It was possible, however, by a readjustment of the field rheostat, to bring the original load back to the station, but in this event it was necessary to give the converter a leading power factor. It is very important to enforce a general rule requiring that all machines should be operated on a system at unity power factor, for in this case the whole system operates at its highest efficiency. The condition of the brushes has much to do with the manner in which a machine will take its share of the load and will sustain overloads. A machine whose commutator has been carefully sand-stoned, whose brushes are clean, and whose brush tension is not over 3 lb., will oftentimes easily sustain overloads of 100% for considerable periods of time, whereas if the machine is not in good condition it will spark badly with slight overloads.

**Recent Developments in Converters.**—Several new developments in converters have been made during the past few years. These consist of the vertical rotary, the rotary with compensating poles, and the rotary with interpoles. The vertical rotary is similar in construction to the ordinary

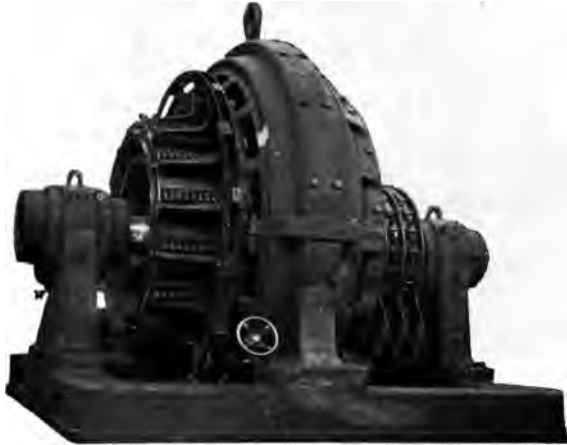

FIG. 406.—Booster Converter (Westinghouse).

rotaries, except that its shaft is vertical instead of horizontal, supported upon a special form of roller bearing. The main advantage claimed for this machine is that it has less weight, that it occupies less space, and that the brushes can be got at more readily than with the ordinary machine. The compensating pole converter, or the booster converter, Figs. 406, 407, 408, was developed with a view to eliminating the induction regulator from electric lighting circuits. The induction regulator is used to raise or lower the voltage on the alternating current side of the machine. The regulator has two windings, a series and a shunt winding—the phase of a fixed e. m. f. in the series winding is changed,



FIG. 407. — Booster Converter (Westinghouse).



FIG. 408. — Booster Converter.

adding the e. m. f., vectorially increasing or decreasing the resulting line voltage. The converter of the booster type has an additional series of poles surrounding the armature,

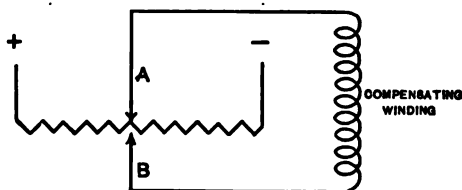

FIG. 409.—Position of Zero Boost on Converter.

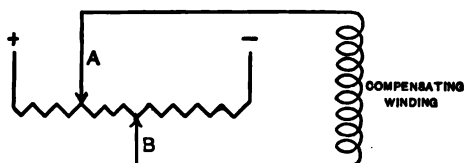

FIG. 410.—Boost in a Positive Direction on Converter.

these poles being outside of the regular poles, as shown in Figs. 407, 408. These auxiliary poles are excited from a pair of contacts, which move over a resistance shunted across the potential circuit. When the contacts are opposite each other, as in Fig. 409, no difference of potential exists between *A* and *B*, and no current passes through the auxiliary winding, thus producing a zero boosting effect. When the contacts are as in Fig. 410, the current passes through the field winding in one direction, and when they are as in Fig. 411, the current passes through the field winding in the opposite direction, boosting in one case, and crushing the voltage in the other case. As the same armature winding is used for both the regular field winding and the booster field winding, the booster e. m. f. will be alternating in char-

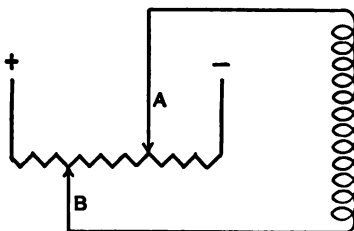

FIG. 411.—Boost in a Negative Direction or Crushing Effect in Converter.

acter, and will have its zero and maximum values occur at the same time intervals as the regular armature e. m. f., or will be in phase with it, simply varying its effective value as the booster field winding is varied. They have been a great improvement over the converters equipped with induction regulators, as the latter occupied considerable space, were



FIG. 412. — Interpole Converter.

difficult to repair, and did not give so large a voltage variation as the booster converter. It is important to remember, in installing the booster converter, that the variable potential resistance for the booster fields should have sufficient contacts so that the potential of the converter will not be varied by too great steps.

The interpole converters consist of a series of small poles called interpoles, which are placed alongside of the larger poles, as in Figs. 412, 413, and which result in increasing or decreasing the polar span. These machines were developed by the General Electric Company. They perform the same function as the auxiliary poles of the booster



converter, that is, they raise or lower the direct current voltage; the result, however, is accomplished in a slightly different manner. In one case the main field flux is varied, while in the other case two e. m. f.'s are superimposed upon each other.



FIG. 413.— Interpole Converter.

**Rotary Converters versus Motor Generators.**—Without doubt the use of the motor generator does much to improve the power factor on systems carrying a large induction motor load. The equipment, however, for the same conversion of kilowatt from alternating to direct is greater for the motor generator than for the converter equipment, since a synchronous motor or an induction motor with suitable switch gear is necessary. With the synchronous motor the operator has good control of the power factor, but loses time in synchronizing. With the induction motor, no control of power factor is possible, but the machine will not fall out of step so easily as it does with a synchronous motor. It may be well to mention, also, that with the converter a minimum space is required, especially where

the induction regulator is not used, that the range of voltage variation is not so great as with the motor generator, and that the general improvement in power factor on the system is nowhere near so large. Converters should be used for city work where the direct current load is heavy, and where little alternating current is used for an induction motor load. For large outlying territory, where much alternating current inductive load is used, and where the voltage conditions are variable, owing to the absorption of many small plants, the motor generator has been found to give excellent service. This system has been used by the Boston Edison Company with great success. If it were possible to obtain rotary converters which would operate satisfactorily on 60 cycles, it is possible that they would be used in many places where the motor generator is now installed.

#### QUESTIONS

1. How is a rotary converter constructed ?
2. What is meant by the term synchronizing? Give several methods.
3. Why is it desirable to operate a converter at unity power factor?
4. Give the relative advantages and disadvantages of the different methods of synchronizing.
5. When starting from the alternating current side with field circuit open, why can the operation of a converter be considered as equivalent to that of an induction motor?
6. Why does a change in the field resistance of a converter from temperature cause a change in the power factor ?
7. What is meant by the hunting of a converter, and how may the effect be minimized?
8. Given one converter having four poles, and the other having eight poles, what will be their relative speeds when in synchronism with the same source?
9. Why is the relation between alternating e. m. f. and direct current e. m. f. fixed for a converter?
10. Derive the relation of direct and alternating e. m. f.'s for a three-phase machine.

1  
2  
3  
4  
5  
6  
7  
8  
9  
10  
11  
12  
13  
14  
15  
16  
17  
18  
19  
20  
21  
22  
23  
24  
25  
26  
27  
28  
29  
30  
31  
32  
33  
34  
35  
36  
37  
38  
39  
40  
41  
42  
43  
44  
45  
46  
47  
48  
49  
50  
51  
52  
53  
54  
55  
56  
57  
58  
59  
60  
61  
62  
63  
64  
65  
66  
67  
68  
69  
70  
71  
72  
73  
74  
75  
76  
77  
78  
79  
80  
81  
82  
83  
84  
85  
86  
87  
88  
89  
90  
91  
92  
93  
94  
95  
96  
97  
98  
99  
100

## APPENDIX

### EXPERIMENTAL PROJECTION APPARATUS

(FOR THE TEACHER)

WHERE many students have to be instructed simultaneously, where the time is limited in which a given subject must be taught, and where the ground to be covered is extensive, there is no better method of instruction than with experimental lectures. While it is true that it requires about five hours to arrange the apparatus for one hour's lecture, the benefits which the student derives from such lectures far outweighs the extra labor in their preparation. Psychologists have shown that with the experimental method of presentation, the ability of the student to remember is increased about tenfold. This result is due to the fact that the student's ability to observe is increased, and that new forms of memory association arise from seeing the experiments performed. The student not only gets a better conception of various physical phenomena, but he understands and is able to remember better the fundamental principles of the science.

It is interesting in developing the experimental method of presenting the subject of electricity, to note to what extent this method may be employed. So far, the author has been unable to find any experiment ordinarily performed in the electrical laboratories which cannot be performed on the lecture table, in such a manner that all readings of instruments can be made by the students, and all calculations can be readily followed. An instance of this may be cited, namely, the measurement of the power factor of an alternating current arc lamp. The arc lamp is operated from an alternating current source of supply, the volts, amperes, and watts of the lamp circuit being given by means of a projecting alternating current ammeter, a projecting alternating current voltmeter, and a projecting wattmeter. This requires two projecting lanterns, as the voltmeter reading, which is constant, is taken first, then an ammeter is substituted for it, the wattmeter reading being projected by means of the other lantern. For ordinary work an experimental lantern having large condensers, 6", with a combination vertical and

horizontal attachment, provided with detachable separate condensers, having binding posts for electrical pressure, also a small table to hold electrolysis tanks, prisms, and instruments, is especially desirable. In case there may be some who are not acquainted with the details of an experimental lantern, one designed by the author, and built by Beseler & Co., of 251 Centre Street, New York, is described.

**The Experimental Lantern.** — The experimental projecting lantern, Figs. 414, 415, used by the author, is somewhat similar to the ordinary college lantern, Fig. 416, except that the lantern is equipped with extra large



FIG. 414. — Experimental Lantern arranged for Horizontal Projection.

detachable condensers, which may be quickly removed during a lecture. In building this lantern a simple patented device was used which held the condensers in position so that either condenser could be removed independently of the other, one condenser being removed from the front, the other from the side. With this arrangement the condensers have so much freedom in their supports that they never break, although a 25-ampere arc is often used in the lantern. The lantern box is built of sheet iron, with special arrangements for ventilation, to which the condenser holder is rigidly attached. The condensing lenses holder of

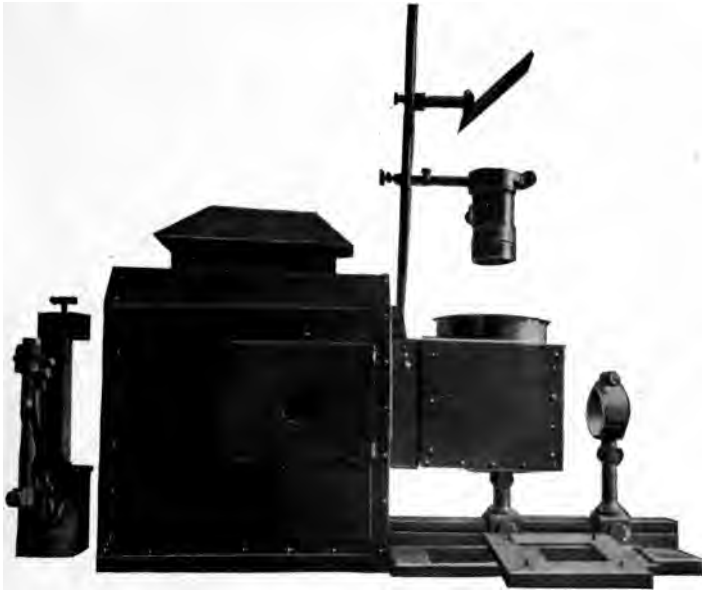

FIG. 415.—Experimental Lantern arranged for Vertical Projection.

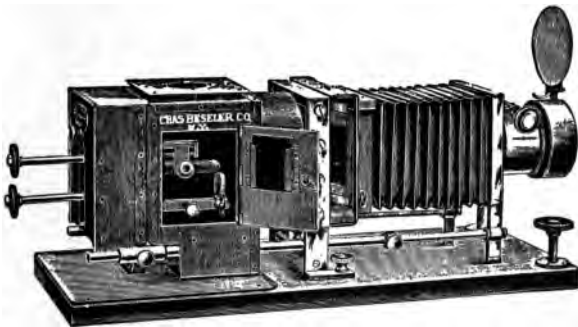

FIG. 416.—Single Lantern.

such a lantern should not be mounted on a separate support, as it interferes with the use of the vertical attachment.

An automatic lamp, Fig. 419, is used with this lantern which can be turned on and off, either at the lantern or at the lecture table. This lamp, Fig. 419, operates at about 18 amperes, this being sufficient current to use. The lamp is mounted upon a sliding support so that it can be moved forward or backward about an inch, and also raised. Although a right-angled feed lamp, Fig. 417, gives a better projection than the ordinary automatic vertical feed lamp, there are no automatic right-angled feed lamps on the market that are satisfactory for this work. When properly adjusted the vertical lamp gives an excellent projection, the light remaining steady while in use.

In front of the lamp house is mounted a rectangular base, Fig. 414, which supports the various objects placed before the lamp house. These consist of a lens holder which carries a  $\frac{1}{4}$  size Darlot lens, so that the lantern can be operated about 15 feet from the lecture table. This is necessary, as one must continually pass to and fro from lantern to lecture table during a lecture. Some lecture rooms are arranged so that the lantern can be placed on the lecture table and may project on the side wall. This arrangement is somewhat more convenient for a large room. Another support consists of an adjustable table about 3" in width and 6" long, which can be raised or lowered. Projecting instruments, tanks containing liquids, as for electrolysis experiments, small electro-magnets, can be placed upon the table close to the condensing lens, and projected on the screen. On the lantern box over the condensers are two double binding posts mounted upon insulated supports. These can be used in supplying current to small devices which have to be operated before the lantern. The slide carrier has four tapering pins upon it which fit into four holes on the condenser. The vertical attachment is supported by a table in front of the condensers, the outer condenser being removed and placed in the top of the vertical attachment. The objective lens is mounted in a support on the vertical attachment. A small pivoted mirror directs the image on the screen to any desired point. The objective lens is clamped in position by a screw. It is possible to change over the horizontal lantern to a vertical lantern in one minute during a lecture. A  $45^\circ$  mirror is mounted inside of the vertical attachment, where it is protected.

**How to operate an Electric Projecting Lantern.** — An outfit for an electric projecting lantern comprises the following apparatus: one arc

lamp; either hand or automatic feed; one rheostat, either adjustable or fixed; one lantern box with appurtenances; one double-pole switch with fuse; one coil of flexible wire; and two carbons.

This apparatus should be connected up with insulated wires in the manner indicated in Fig. 417, so that the arc lamp can receive electric

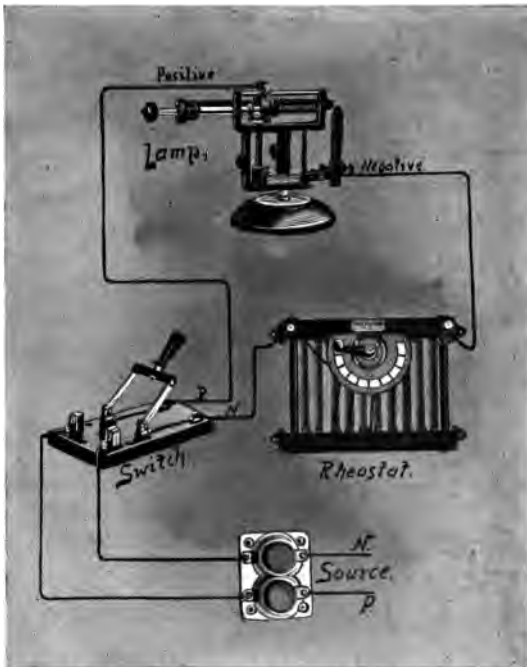

FIG. 417. — Lantern Set-up.

current from a suitable source. When selecting a proper service upon which to operate an electric lantern, care should be taken to see that the service wires are of sufficient capacity to carry the lantern current without danger of becoming overheated and causing fire. An operator should *never* seek to obtain lantern current by means of an attachment plug connected in a lamp receptacle, a cluster, or a lamp circuit of any kind; the electrical connection must be made at a regular outlet or a



junction box connected in on the mains. Data on this point may be found in the Fire Underwriters' rules.

When the set-up is being made for direct current, care should be taken to note that the positive lead is connected to the upper carbon. Whether the connections are correct or not can readily be determined by allowing the lamp to burn for a short time, then opening the circuit, and observing which carbon is the brighter as they cool, for the positive carbon will remain bright longer. If the positive carbon should happen to be the lower one, the connecting wires can easily be reversed at the lamp terminals.

To operate the lamp ordinarily, see that there is electric pressure beyond the fuses. If it be a low voltage circuit of 116 volts this can be readily determined either by connecting an incandescent lamp across the mains or by moistening the thumb and forefinger of one hand and placing them across the circuit. A tingling sensation in the fingers will indicate the presence of volts. The latter method is not advisable unless the voltage of the service is known, for if an operator were to try this on a 500-volt service it would probably burn his fingers severely. When there is pressure beyond the fuses, separate the carbons. Then, if a hand feed lamp is used, set the handle of the adjustable rheostat in such a position that all of its resistance is in the circuit, and close the main switch. The carbons may then be brought into contact by turning the handle of the lamp mechanism. When the carbons are in contact they should be slowly separated, turning the lamp handle in the opposite direction. The rheostat handle should then be moved to such a position that the desired current passes through the arc. As the carbons burn away they should be fed together gradually, the distance between the arc for a right-angled hand feed lamp being about  $\frac{1}{4}$  of an inch. If the upper carbon extends over the lower one too far, the upper carbon will not burn away properly but will form a long tip, causing the arc to sputter.

With automatic lamps manipulation of the carbons is unnecessary.

**Theory.** — Intelligent operation of an electric lantern requires the knowledge of the application of Ohm's law.

It is customary when describing the general application of this law to use the term "an electric circuit." An electric circuit consists of a complete conducting path from one terminal of an electric generator, through the consuming device, to the other terminal of the generator. By means of a system of copper feed wires, the terminals of the main



FIG. 418.— Two Lamps in Series.

#### How to connect Two Lamps in Series.

(1) If it is desirable to operate a dissolving lantern from a 116-volt service which is wired with a carrying capacity of about 18 amperes (wire No. 10), two lamps may be connected in series with one rheostat adjusted to pass a current not greater than one lamp.

(2) Two lamps may be operated in series with two rheostats from a 220-volt service, as Fig. 418.

Never use wire for arc lamps smaller than No. 10 B. & S.

generator at the power house are connected directly to outlets in many buildings in large cities. In some cases each building is equipped with its own generators located in the sub-cellar, to which the outlets are wired directly. These outlets are usually protected with a fuse and a switch, the function of the switch being to disconnect the consuming device connected to it, and the function of the fuse being to limit the energy supply. If the demands of the consuming device be greater than the capacity of the fuse, the fuse will melt, opening the circuit.

The application of Ohm's law to a lantern circuit may be shown as follows: Consider the electrical connections for a single projecting lantern, Fig. 417. They consist of the mains (source) coming from the main generator, terminating in the fused double pole switch. From one terminal of the switch a wire connects to one of the carbons of the lamp, the other terminal of the switch being connected to one of the terminals of the rheostat. With the switch open, the remaining terminals of the rheostat and the lamp are connected together. The switch is then closed and the carbons are adjusted until they touch and form a spark. The carbons are then separated about an eighth of an inch, producing a brilliant arc. Assume that the resistance of the rheostat is such that a current of 15 amperes is passing through the circuit. Assume also that the pressure of the circuit at the source is 120 volts. Under ordinary operating conditions an arc requires a pressure across its terminals of 40 volts for proper operation. If the arc consumes 40 volts and the resistance across the whole circuit is 120 volts, obviously the resistance must consume 80 volts.

If a current of 15 amperes passes through a resistance and the pressure across its terminals is 80 volts, what, according to Ohm's law, will the resistance be? The answer is 5.33 ohms, obtained by dividing 80 by 15. If we were to measure the voltage across the carbons of the arc with a voltmeter, it would here be 40 volts, while the voltage across the resistance would be 80 volts. It must be remembered that the arc usually consumes 40 volts, and this must be subtracted from the total voltage to obtain the net voltage consumed by additional resistance. Thus, on a 220-volt circuit, 180 volts must be consumed; on a 50-volt circuit 10 volts must be consumed, and on a 500-volt circuit, 460 volts must be consumed.

Having determined the voltage which must be consumed in any case, the proper resistance to limit the flow of a given current can be obtained directly from Ohm's law. Thus, given an arc lamp fed

through a resistance from a 120-volt circuit, what resistance is necessary to pass currents of 15, 18, 20, and 25 amperes? We proceed thus :

Total pressure,	. . .	120 volts
Lamp pressure,	. . .	<u>40 volts</u>
Remaining pressure,		80 volts
For 15 amperes,	$80/15 =$	5.33 ohms
For 18 amperes,	$80/18 =$	4.44 ohms
For 20 amperes,	$80/20 =$	4.00 ohms
For 25 amperes,	$80/25 =$	3.20 ohms

In a similar manner other conditions may be worked out.

**Hand-feed Arc Lamp.** — A hand-feed lamp is a mechanism consisting of two movable arms which are insulated from each other. These two arms have holes in their extremities which contain carbons. These carbons are so supported by the arms of the mechanism as to be able to move in the same plane. The support to the arms is usually in the form of a screw, so that the carbons may be fed together at a definite rate as they are consumed. When burning upon direct current, the positive carbon, which is the upper one, burns away twice as rapidly as the negative carbon. It is therefore obvious that the mechanism must feed the positive carbon twice as rapidly as the negative carbon. When using alternating current, however, both carbons are consumed at the same rate, and consequently both carbons must be fed together at the same rate. The improved Sunray hand-feed lamp, Fig 417, is arranged with inter-

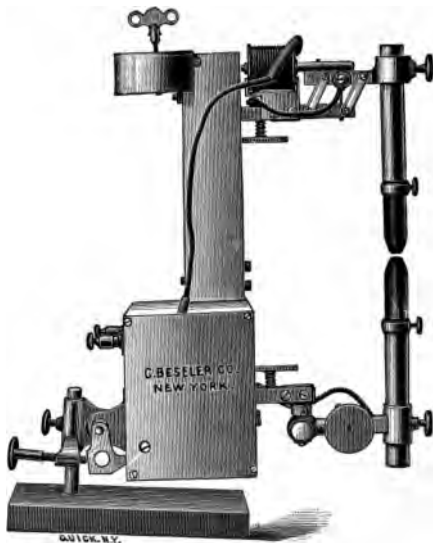

FIG. 419. — Automatic Arc Lamps.

changeable gears so that it can be used either on direct or alternating current. For instance, as the gears are set on cut, the lamp is arranged for direct current. If, however, it is desirable to use alternating current,



FIG. 420. — Combination Beseler Double Lantern and Moving Picture Apparatus. one thumbscrew is released, another thumbscrew is unscrewed, and its screw is removed. It is then possible to move the upper carbon holder forward so that its gear meshes with the inner gear on the lower carbon holder. This gear has the same number of teeth as the upper gear, and consequently both carbons may be fed together at the same rate.

**Rheostats.**—The function of a rheostat is to limit the supply of electrical energy furnished an arc lamp, and also to help maintain a steady arc. It has been found undesirable in practice to operate an arc lamp directly upon a service without resistance in its circuit, since the resistance of the arc varies over such wide ranges of values. When the carbons are in contact the resistance of the arc is practically zero, except for what may be due to the structure of the carbons. If in this condition the arc lamp were connected up without resistance to a low voltage circuit, it would pass an excessive current.

A rheostat for lantern use is usually wound of resistance wire coiled up in the form of a helix. This wire must have sufficient carrying capacity so that it will not heat excessively. Its temperature should not rise above 550° F., and the whole structure of the rheostat must be mounted in a sheet-iron enclosing frame. The resistance wires of the rheostat should be insulated from the framework of the rheostat at the points at which they are supported, so that the framework will not form what is termed a short circuit.

The most practical rheostats for projection work are made variable, to increase or decrease the amperage according to conditions that may arise.

**Moving-film Apparatus.**—It is sometimes convenient in using a double lantern, to have it arranged with a moving-picture attachment, especially when showing films of e. m. f. and current phenomena. A convenient apparatus made by Beseler & Co. for this purpose is shown in Fig. 420. As the moving-picture attachment requires a more powerful light, the lower lamp house is arranged to slide back and forth to be used in operating the film apparatus or as the lower half of the double lantern opposite.

**Projecting Electrical Instruments.**—Throughout the text reference has frequently been made to four electrical projecting instruments, a galvanometer, a wattmeter, an alternating current voltmeter, and an alternating current ammeter. All of these instruments, Figs. 421, 422, were built by Dr. Edward Weston for projection. The alternating current ammeter is a self-contained 10-ampere instrument, the alternating current voltmeter is a 150-volt instrument, and the wattmeter is a regular 300-watt laboratory instrument arranged with a transparent scale. The galvanometer is only 5 inches in diameter, and has a transparent scale graduated in 50 parts, central zero, with zero shifting device. This instrument is made from a specially designed Weston movement, possessing all of the character-

istics of this type of permanent magnet instrument. The galvanometer may be used to show induction experiments, or it may be used with shunts as an ammeter or with resistance as a voltmeter. A double-

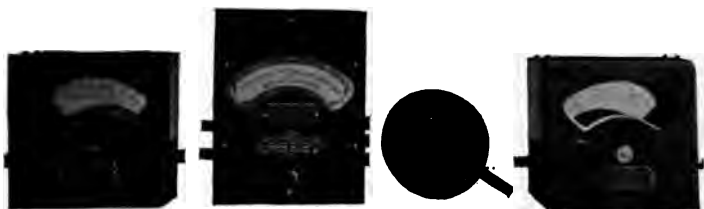

FIG. 421.— Weston Projecting Instruments.

throw double-pole switch is usually arranged so that the galvanometer terminals come to the middle of the switch; the switch when thrown in one direction indicates volts, and when thrown in the other direction indicates amperes. For speed measurements a Weston speed tachome-



FIG. 422— Combination Board used with Projecting Galvanometer.

ter is belted to the apparatus under test, and the magneto terminals are wired to the galvanometer with resistance in the circuit. This resistance is varied until a uniform relation is obtained between speed

and deflection. This arrangement is particularly advantageous when the lecturer is discussing the operating characteristics of motors. For temperature work the galvanometer may be connected to a thermo element. Great accuracy can be obtained by having two junctions, such as copper to nickel to copper, and placing one junction in water, and the other junction in contact with the temperature point that is being measured. The difference in temperature between the water and the temperature point is indicated by the galvanometer. The thermo e. m. f.'s corresponding to various combinations of metals may be found in Thomson's Elementary Lessons in Electricity.

As a suitable adjunct to this text the author recommends Sloan's Elementary Electrical Calculations, in which will be found numerous practical problems.



## FORMULÆ

	PAGE
$I = K\sqrt{\theta}$ . . . . .	30
$E = \frac{\phi \times N \times S}{10^8}$ . . . . .	48
Circular mil = diameter in mils squared.	
One mil = $\frac{1}{1000}$ of an inch. . . . .	61
Resistance = $\frac{10.35 \times \text{length}}{\text{cross section in circular mils}}$ . . . . .	62
$R = r_1 + r_2$ . Series resistances. . . . .	62
$R = \frac{r^1 r^2}{r^1 + r^2}$ . Multiple resistances. . . . .	63
$R_t = R_0(1 + .0042 t)$ . Temperature coefficient. . . . .	63
$E = 1.4328 - 0.00119(t - 15^\circ \text{C.}) - 0.000007(t - 15^\circ \text{C.})^2$ . E. m. f. standard Clark cell. . . . .	68
$E = 1.01985$ volts. E. m. f. Weston standard cell. . . . .	68
$I = \frac{E}{R}$ . . . . .	72
$R = \frac{E}{I}$ . . . . .	73
$E = IR$ . . . . .	73
$e : e' :: R : R'$ . Distribution of potential. . . . .	74
$M = Izt$ . Faraday's electrolysis formulæ. . . . .	103
$R = \frac{E}{I - \frac{E}{R'}}$ . . . . .	125
$e : e' :: R : R + R'$ . Calibration of voltmeter. . . . .	136
$A : B :: O : x$ . Slide wire bridge. . . . .	141
$X = C + \phi(S' - S)$ . Carey-Foster Bridge. . . . .	144
$X = C - \phi(S' - S)$ . Carey-Foster Bridge. . . . .	144
$A : B :: C : D :: E : X$ . Thomson Double Bridge. . . . .	144
$K = \frac{e}{r \times \theta}$ . Constant of galvanometer. . . . .	148

	PAGE
$C : C :: \theta : \theta'$ . Measurement of Capacity. . . . .	149
$I = \frac{E - E'}{R}$ . Motor Armature Current. . . . .	159
$\frac{\text{Actual revolutions} \times 100}{\text{allotted revolutions}}$ = percentage of accuracy of meter.	229
$\frac{A + B + 3C}{5}$ = average per cent accuracy of wattmeter. . . . .	235
Effective value = $\frac{\text{max.}}{\sqrt{2}} = \frac{\text{max.}}{1.41}$ . . . . .	250
$U = I^2 R t \times .24$ . Heat developed in a circuit. . . . .	251
Maximum = $\frac{\pi}{2} \times \text{average} = 1.57 \times \text{average}$ . . . . .	252
F. F. = $\frac{\text{effective}}{\text{average}}$ .	
F. F. = $\frac{\frac{1}{\sqrt{2}} E_{\text{max.}}}{\frac{2}{\pi} E_{\text{max.}}} = 1.11$ . . . . .	252
$I = 2 \pi f C e$ , $I = \frac{e}{\frac{1}{2 \pi f C}}$ . Capacity alternating circuit. . . . .	257
$c = \frac{1}{\frac{1}{c^1} + \frac{1}{c^2} + \frac{1}{c^3}}$ . Condensers in series. . . . .	259
$E_s = -L \left( \frac{di}{dt} \right)$ . E. m. f. of self-induction. . . . .	260
$L = \frac{\text{flux} \times \text{number of turns}}{\text{current} \times 10^8} = \frac{\phi N}{I \sqrt{2} \times 10^8}$ . . . . .	261
$E_{\text{avg.}} = \frac{4 f \phi N}{10^8}$ . . . . .	262
$E_f = 2 \pi f L I$ = effective e. m. f. of self-induction. . . . .	263
$\sin 30^\circ = \frac{1}{2} = .5 = \cos 60^\circ$ . . . . .	269
$\cos 30^\circ = \frac{\sqrt{3}}{2} = .866 = \sin 60^\circ$ . . . . .	269
$\tan 30^\circ = \frac{1}{\sqrt{3}}$ . . . . .	269

	PAGE
$\tan 60^\circ = \frac{\sqrt{3}}{1}$ . . . . .	269
$\sin \theta = \frac{2 \pi f L I}{I \sqrt{R^2 + (2 \pi f L)^2}} = \frac{2 \pi f L}{\sqrt{R^2 + (2 \pi f L)^2}}$ . . . . .	270
$\cos \theta = \frac{R I}{I \sqrt{R^2 + 2 \pi f}} = \frac{R}{\sqrt{R^2 + (2 \pi f L)^2}}$ . . . . .	270
$\tan \theta = \frac{2 \pi f L}{R I} = \frac{2 \pi f L}{R} = 2 \pi f \frac{L}{R}$ . . . . .	270
$Z = \sqrt{R^2 + \left(2 \pi f L - \frac{1}{2 \pi f C}\right)^2}$ . . . . .	272
Resonance when $2 \pi f L = \frac{1}{2 \pi f C}$ . . . . .	272
$I = \frac{E}{Z} = \frac{E}{\sqrt{R^2 + \left(2 \pi f L - \frac{1}{2 \pi f C}\right)^2}}$ . . . . .	272
$AB = AD \times \cos \theta$ , $\cos \theta =$ power factor. . . . .	275
$P = E \times I \times \cos \theta$ . . . . .	276
$\frac{P}{E \times I} =$ power factor. . . . .	276
$\tan \theta = \sqrt{3} \frac{W_1 - W_2}{W_1 + W_2}$ . Tangent formulæ three-phase power circuit . . . . .	277
$\frac{W_1}{W_2} = \frac{\cos(\theta + 30^\circ)}{\cos(\theta - 30^\circ)}$ . . . . .	277

# INDEX

- Abscissa, 12.
- Acid solutions, 103.
- Admittance, 266, 272.
- Aging of magnets, 18.
- Air gap, 6.
- Alkalies, 111.
- Alternating currents, 49.
  - arc, 186.
  - circuit, 195, 270.
  - generators, 252.
  - principles of, 242.
- Aluminium, 113.
- Ammeters, 17, 19.
  - calibration of, 129.
  - calibration of, series method, 131.
  - shunt, 22.
  - Thomson inclined coil, 41.
  - voltmeter method of measuring resistances, 125.
- Ampere, 59.
- Arc lamps, 186.
  - circuits, 192.
  - hand-feed, 337.
- Armature, circuits, 155, 159.
  - cross section, 40.
  - field of series motor, 175.
  - of motor, 37.
  - shunt connection, 170.
- Attraction and repulsion of magnets, 2.
  
- Balance coil, for arc lamps, 193.
  - set for a. c., e. m. f.'s, 246.
- Balances, 51.
- Ballast resistance, life of, 220.
- Barium cyanide, 116.
  - hydrate, 116.
- Bleach, 111.
- Bliss Car Lighting System, 53.
- Blow-out magnets, 33.
- Booster converter, 322.
- Box negative, 97.
- Branch circuits, 124.
- Brass plating, 110.
  
- Bridge control, 182.
- Bunsen cell, 86.
- Busses, 26.
- Buzzer, 35.
  
- Cables, 26.
- Capacity, 242, 254.
  - current relations, 257.
  - effect, 255.
  - formulae, 257.
  - measurement of, 149.
  - reactance, 257, 272.
- Carbon arc, 188.
  - incandescent lamps, 202.
  - physics of, 188.
- Carbonizing filament, 206.
- Carbons, 186.
- Carborundum, 115.
- Carey-Foster bridge, 143.
- Cell, Daniell, 83.
  - closed circuit, 83.
  - e. m. f.'s, 79.
  - open circuit, 87.
  - simple, 77.
- Characteristic curves, shunt motor, 178.
- Chemical action of cell, 78.
- Chloride cells, 96.
- Circuits of shunt motor, 153.
- Circular mil, 61.
- Coefficient of self-induction, 260.
- Coherer, 55.
- Color of illuminants, 197.
- Commutator of motor, 39.
- Compass, 2.
- Compensating coil, T. R. W., 222.
- Condenser, 111, 258.
  - electrolytic, 82.
- Conductivity of  $PbO_2$ ,  $PbSO_4$ , 91.
  - copper sulphate, 102.
  - sodium acetate, 141.
- Contact maker, 244.
- Controller, testing, 184.
  - series multiple, 180.

- Converter, booster, 322.  
   in parallel, 320.  
   interpole, 322.  
 Cooper-Hewitt tube, 216.  
 Coordinate paper, 122.  
 Copper electrode, 85.  
   plating, 108.  
   wire table, 65.  
 Cosine, 268.  
 Counter e. m. f. of motor, 159.  
 Critical current density, 110.  
 Current, 59, 69, 70, 71.  
 Cycle, 243.  
   of magnetism, 10.  
  
 Daniell cell, 83.  
 Davy's discovery of arc, 186.  
 Daylight lamp, 196.  
 Depolarizers, 81.  
 Dip of magnet, 4.  
 Direct method of meter test, 228.  
 Double current generators, 49.  
 Dry cells, 88.  
 Drying filaments, 205.  
 Dynamotor, 50.  
  
 Eddy currents, 18, 53, 223.  
 Edison bottle meter, 221.  
   cell, 95.  
   lamp, 203.  
   three-wire system, 119.  
 Effective values, 250.  
 Efficiency of illuminants, 191.  
 Electric bell, 34.  
   furnace, 114.  
 Electro-chemical equivalents, 103.  
   dynamometer, 29.  
 Electrodes, effect of changing, 79.  
 Electrolysis, 101.  
   of water, 105.  
 Electrolytes, defined, 101.  
   effect of changing, 80.  
 Electrolytic condenser, 82.  
   interrupter, 117.  
   products, 111.  
   rectifier, 116.  
 Electro-magnet, 32, 16.  
 Electro-motive force, 59.  
   generation, 47.  
 Electroplating, 108.  
 Electromotive brake, 183.  
  
 Enclosed arc, 195.  
 Exide battery, 98.  
 Experimental coil, 27.  
   projection, 330.  
   tank, 78.  
  
 Faraday, Michael, 46.  
 Feeder ammeter, 131.  
 Field coils of motor, 37, 154.  
   rheostat, 167.  
 Filament, characteristics of, 209.  
   mount, 208.  
   treating of, 206.  
 Flaming arc, 198.  
 Flashing filament, 204.  
 Flux, 6.  
   density, 6.  
 Form factor, 252.  
 Foucault currents, 53.  
 Friction, of recording wattmeter, 227.  
   curves of meter, 222.  
  
 Galvani's experiment, 77.  
 Galvanometer, 145.  
   determination of constant, 149.  
   how to set up, 147.  
   resistance of, 147.  
   shunt, 140.  
 Gears, T. R. W., 223.  
 Gem lamp, 209.  
 Generating e. m. f.'s, 244.  
 Generator, 48.  
 Gillette's safety razor, 15.  
 Glower for Nernst lamp, 219.  
 Gold plating, 109.  
 Graphite, 114.  
 Gravity cell, 85.  
 Grenet cell, 86.  
 Ground, resistance of, 171.  
   tests, 169.  
 Grove cell, 86.  
  
 Helix, 27.  
 Holophane reflector, 198.  
 Horseshoe magnet, 4.  
 Hunting, 313.  
 Hydrometer, 94.  
 Hysteresis cycle, 9.  
   loss, 10.  
  
 Inductance, 242.

- Inductance formulæ, 261.  
 Induction, 28.  
   coil, 55.  
   generator, 253.  
   magnetic, 7.  
   motor, 38, 299.  
   motor, care of, 305.  
   motor, operation, 302.  
   motor, rotation, 305.  
   poles, 301.  
   wattmeter, 279.  
 Inductive e. m. f. and current relation, 265.  
   reactance, 272.  
 Infra rays, 190.  
 Inspection tests of motor, 234.  
 Installation tests, 233.  
 Insulation test, 144.  
 Interpole converters, 322.  
   motors, 172.  
 Intrinsic brightness, 189.  
 Iron core in helix, 31.  
  
 Keeper for magnet, 
  
 Laminated shields, 23.  
 Lamp board, 130.  
 Leakage, magnetic, 6.  
 Leclanché cell, 87.  
 Limit switch, 29.  
 Lines of force, 6, 46.  
   effect on compass, 26.  
 Load, 236.  
   box, 232.  
 Local action, 84.  
 Lodestone, 1.  
 Low voltage obtained, 75.  
  
 Magnet, 1.  
   horseshoe, 4.  
   of Weston voltmeter, 5.  
   pole, 2, 15.  
 Magnetic circuits of motor, 156.  
   of series motor, 175.  
   dip, 4.  
   field, 14.  
     around wire, 25.  
   pole, 3.  
   leakage, 6.  
   induction, 7.  
   spectrum, 2.  
  
 Magnetism, 1-24.  
   molecular theory, 6.  
 Magnetite, 1.  
   arc, 199.  
 Magnetization curve, 23, 51.  
 Magnetizing force, 14.  
 Manchester positive, 98.  
 Mariner's compass, 1.  
 Maximum a. c. value, 250.  
 Mayer's needles, 16.  
 Measurement of power factor, 276.  
 Mechanical equivalent of light, 189.  
 Metallic salt solution, 107.  
 Meter installation, 238.  
   service, 237.  
   testing, 227.  
   wiring, 241.  
 Molecular magnets, 16.  
   theory, 6.  
 Moore vacuum tube, 214.  
 Motor, 37.  
   generator, 49, 50, 326.  
 Moving-picture apparatus, 338.  
 Mutual induction, 53.  
  
 Negative temperature coefficient, 209.  
 Nernst lamp, 218.  
 Neutral plane, 157.  
 Normal load, 235.  
 North magnetic pole, 3.  
  
 Ohm, 59, 60.  
   law, 71, 72, 73, 74, 126.  
 Ordinate, 12.  
 Oscillograph, 248.  
 Overload relays, 29.  
   release, 163.  
  
 Pail forge, 118.  
 Parallax, 22.  
 Partial hysteresis curve, 13.  
 Permeability, 10, 31.  
 Phosphorus, 116.  
 Plating, gold, silver nickel, copper, 109.  
 Polarity indicator, 107.  
 Polarization, 80.  
   electrical, 254.  
 Poles of magnet, 2.  
 Post-office box, 139.  
 Potassium chlorate, 113.  
 Potentiometer method of calibrating, 132.

- Potentiometer, Leeds and Northrup, 133.  
 Power in a. c. circuit, 273.  
   factor, 275.  
 Primary and storage batteries, 77.  
 Primary coil, 11.  
 Projection, experimental, 329.  
   instruments, 340.  
   lantern, 332.  
  
 Queen bridge, 150.  
  
 Rating of cells, 92.  
 Reactance in parallel, 273.  
 Relation of resistance and inductance, 263.  
 Relay, 36.  
 Remote control, 163.  
 Residual magnetism, 52.  
 Resistance, 59.  
   car, 60.  
   comparison with voltmeter, 128.  
   measurement of, 125.  
   of conductor, 62.  
   of electrolyte, 143.  
   of pure water, 91.  
   of voltmeter, 22, 126.  
   standard, 129.  
 Resonance, 272.  
 Retentivity, 7.  
 Rolled negatives, 139.  
 Rotary ammeter, calibration of, 131.  
 Rotary converter, 50, 307.  
   e. m. f.'s, 307.  
   hunting of, 313.  
   starting of, 309.  
   starting from a. c. side, 311.  
   starting from d. c. side, 309.  
   starting with induction motor, 311.  
   synchronizing of, 315.  
 Rotating standard, 229.  
   three-phase, 307.  
 Rotating field, 319.  
 Rotation, of motor, changed, 164.  
   of series motor, changed, 180.  
 Ruhmkorff coil, 56.  
  
 Secondary coil, 11.  
 Self-induction, 259.  
 Series motor, 174.  
   control, 182.  
   starting features, 184.  
 Shelf negative, 99.  
  
 Shunt motor, 152.  
   directions for setting up, 161.  
   tests, 170.  
 Single-phase wattmeter, 279.  
 Slide wire bridge, 141.  
 Sodium, 112.  
 Sounder, 36.  
 Spectrum, obtaining of, 187.  
 Speed and tractive effort series motor,  
   177.  
 Speed variation, 165, 168.  
 Sponge lead, 113.  
 Standard cell, 66-68.  
   cell circuit, 134.  
   resistance, 231.  
   resistance method for calibrating watt-  
   meters, 230.  
 Starting boxes, 160.  
   box magnet arm, 162.  
 Station transformers, 293.  
 Stator of induction motor, 299.  
 Storage battery, 89.  
   charging, 93.  
   formulae, 90.  
   operation, 91.  
 Stray field, 26, 55.  
 Synchronizing, 315.  
   with frequency indicator, 317.  
   with voltmeter, 317.  
   with synchroscope, 316.  
 Synchronous motor, 326.  
  
 Tabulated lamp bulb, 207.  
 Tangents, 268.  
 Tanks for projection, 104.  
 Tantalum lamp, 210.  
 Telegraph line, 35.  
 Telephone circuit, 55.  
   receiver, 17.  
 Temperature coefficient, 63.  
   coefficient positive and negative, 102.  
   effect on magnetizability, 8.  
   of arc, 186.  
 Testing meter, 235.  
   sets, 149.  
 Thomson double bridge, 144.  
   inclined coil ammeter, 41.  
   inclined coil voltmeter, 41.  
   inclined coil wattmeter, 42.  
   recording wattmeter, 17, 54.  
   recording wattmeter armature, 221.

- recording wattmeter armature resistance, 222.
- recording wattmeter field coils, 223.
- recording wattmeter magnets, 223.
- recording wattmeter type C, 224.
- Three-phase power, 277.
  - e. m. f.'s, 253.
- Three-wire system, 119.
- Torque of series motor, 177.
- Traction magnets, 44.
- Transformer, 10, 283.
  - connections, 295.
  - coils, 288.
  - cooling, 291.
  - e. m. f.'s, 284.
  - experimental, 288.
  - formulae, 277.
  - losses, 287.
  - lugs, 291.
  - subway, 290.
  - theory, 283.
  - types, 287.
  - ventilation, 291.
- Transmission key, 35.
- Trigonometric expression, 268.
- Trouble, location of, 168.
- Tudor plates, 96.
- Tungsten filament, 212.
  - lamp, 209, 211.
- Two-wire system, 119.
- Type H transformer, 296.
- Ultra rays, 191.
- Unity power factor, 319.
- Vector, 266.
  - relation of inductance and resistance, 268.
- Vibration, effect on magnetizability, 9.
- Volt, 48, 59.
- Voltage, low, obtained, 75.
- Voltmeter, 17, 19.
  - calibration of, 132.
  - method of measuring resistance, 128.
  - Thomson inclined coil, 41.
- Wattmeter disc, 18, 54.
  - indicating, calibration of, 136.
  - on inductive circuit, 281.
  - polyphase, 280.
  - Thomson inclined coil, 42.
  - Weston indicating, 42.
- Weston a. c. ammeter, 251.
  - indicating wattmeter, 42.
  - relay, 21.
  - speed tachometer, 18.
  - voltmeter suspension, 127.
  - voltmeter magnet, 5.
- Wheatstone bridge, 137.
- Wire roller bridge, 142.
- Wireless circuit, 56.



- Potentiometer, Leeds and Northrup, 133.  
 Power in a. c. circuit, 273.  
   factor, 275.  
 Primary and storage batteries, 77.  
 Primary coil, 11.  
 Projection, experimental, 329.  
   instruments, 340.  
   lantern, 332.
- Queen bridge, 150.
- Rating of cells, 92.  
 Reactance in parallel, 273.  
 Relation of resistance and inductance, 263.  
 Relay, 36.  
 Remote control, 163.  
 Residual magnetism, 52.  
 Resistance, 59.  
   car, 60.  
   comparison with voltmeter, 128.  
   measurement of, 125.  
   of conductor, 62.  
   of electrolyte, 143.  
   of pure water, 91.  
   of voltmeter, 22, 126.  
   standard, 129.  
 Resonance, 272.  
 Retentivity, 7.  
 Rolled negatives, 139.  
 Rotary ammeter, calibration of, 131.  
 Rotary converter, 50, 307.  
   e. m. f.'s, 307.  
   hunting of, 313.  
   starting of, 309.  
   starting from a. c. side, 311.  
   starting from d. c. side, 309.  
   starting with induction motor, 311.  
   synchronizing of, 315.  
 Rotating standard, 229.  
   three-phase, 307.  
 Rotating field, 319.  
 Rotation, of motor, changed, 164.  
   of series motor, changed, 180.  
 Ruhmkorff coil, 56.
- Secondary coil, 11.  
 Self-induction, 259.  
 Series motor, 174.  
   control, 182.  
   starting features, 184.  
 Shelf negative, 99.
- Shunt motor, 152.  
   directions for setting up, 161.  
   tests, 170.  
 Single-phase wattmeter, 279.  
 Slide wire bridge, 141.  
 Sodium, 112.  
 Sounder, 36.  
 Spectrum, obtaining of, 187.  
 Speed and tractive effort series motor,  
   177.  
 Speed variation, 165, 168.  
 Sponge lead, 113.  
 Standard cell, 66-68.  
   cell circuit, 134.  
   resistance, 231.  
   resistance method for calibrating watt-  
   meters, 230.  
 Starting boxes, 160.  
   box magnet arm, 162.  
 Station transformers, 293.  
 Stator of induction motor, 299.  
 Storage battery, 89.  
   charging, 93.  
   formulae, 90.  
   operation, 91.  
 Stray field, 26, 55.  
 Synchronizing, 315.  
   with frequency indicator, 317.  
   with voltmeter, 317.  
   with synchroscope, 316.  
 Synchronous motor, 326.
- Tabulated lamp bulb, 207.  
 Tangents, 268.  
 Tanks for projection, 104.  
 Tantalum lamp, 210.  
 Telegraph line, 35.  
 Telephone circuit, 55.  
   receiver, 17.  
 Temperature coefficient, 63.  
   coefficient positive and negative, 102.  
   effect on magnetizability, 8.  
   of arc, 186.  
 Testing meter, 235.  
   sets, 149.  
 Thomson double bridge, 144.  
   inclined coil ammeter, 41.  
   inclined coil voltmeter, 41.  
   inclined coil wattmeter, 42.  
   recording wattmeter, 17, 54.  
   recording wattmeter armature, 221.



LIST OF WORKS  
ON  
ELECTRICAL SCIENCE

PUBLISHED AND FOR SALE BY

D. VAN NOSTRAND COMPANY,  
23 Murray and 27 Warren Streets, New York.

---

- ABBOTT, A. V.** *The Electrical Transmission of Energy. A Manual for the Design of Electrical Circuits. Fifth Edition, enlarged and rewritten. With many Diagrams, Engravings and Folding Plates.* 8vo., cloth, 675 pp. . . . . Net, \$5.00
- ADDYMAN, F. T.** *Practical X-Ray Work.* Illustrated. 8vo., cloth, 200 pp. . . . . Net, \$4.00
- ALEXANDER, J. H.** *Elementary Electrical Engineering in Theory and Practice.* A class-book for junior and senior students and working electricians. Illustrated. 12mo., cloth, 208 pp. . . . . \$2.00
- ANDERSON, GEO. L.** *Handbook for the Use of Electricians in the operation and care of Electrical Machinery and Apparatus of the United States Seacoast Defenses.* Prepared under the direction of Lieut.-General Commanding the Army. Illustrated 8vo., cloth, 161 pp. . . . . \$3.00
- ARNOLD, E.** *Armature Windings of Direct-Current Dynamos.* Extension and Application of a general Winding Rule. Translated from the original German by Francis B. DeGress. Illustrated. 8vo. cloth, 124 pp. . . . . \$2.00

- ASHE, S. W.** Electricity Experimentally and Practically Applied. 422 illustrations. 12mo., cloth, 375 pp. . . . . Net, \$2.00
- ASHE, S. W., and KEILEY, J. D.** Electric Railways Theoretically and Practically Treated. Illustrated. 12mo., cloth.
- Vol. I. Rolling Stock. *Second Edition*. 285 pp. . . . . Net, \$2.50
- Vol. II. Substations and Distributing Systems. 296 pp. . . . Net, \$2.50
- ATKINSON, A. A.** Electrical and Magnetic Calculations. For the use of Electrical Engineers and others interested in the Theory and Application of Electricity and Magnetism. *Third Edition, revised*. Illustrated. 12mo., cloth, 310 pp. . . . . Net, \$1.50
- ATKINSON, PHILIP.** The Elements of Dynamic Electricity and Magnetism. *Fourth Edition*. Illustrated. 12mo., cloth, 405 pp. . \$2.00
- Elements of Electric Lighting, including Electric Generation, Measurement, Storage, and Distribution. *Tenth Edition*, fully revised and new matter added. Illustrated. 12mo., cloth, 280 pp. . . . . \$1.50
- Power Transmitted by Electricity and Applied by the Electric Motor, including Electric Railway Construction. Illustrated. *Fourth Edition*, fully revised and new matter added. 12mo., cloth, 241 pp. . . \$2.00
- AYRTON, HERTHA.** The Electric Arc. Illustrated. 8vo., cloth, 479 pp. . . . . Net, \$5.00
- AYRTON, W. E.** Practical Electricity. A Laboratory and Lecture Course. Illustrated. 12mo., cloth, 643 pp. . . . . \$2.00
- BAKER, J. T.** The Telegraphic Transmission of Photographs. 63 illustrations. 12mo., cloth, 155 pp. . . . . Net, \$1.25
- BEDELL, FREDERICK.** Direct and Alternating Current Testing. Assisted by C. A. Pierce. Illustrated. 8vo., cloth, 250 pp., Net, \$2.00
- BEDELL, F. & CREHORE, ALBERT C.** Alternating Currents. An analytical and graphical treatment for students and engineers. *Fifth Edition*. 112 illustrations. 8vo., cloth, 325 pp. . . Net, \$2.50
- BIGGS, C. H. W.** First Principles of Electricity and Magnetism. Illustrated. 12mo., cloth, 495 pp. . . . . \$2.00
- BONNEY, G. E.** The Electro-Plater's Hand Book. A Manual for Amateurs and Young Students of Electro-Metallurgy. *Fourth Edition, enlarged*. 61 Illustrations. 12mo., cloth, 208 pp. . . . . \$1.20

- BOTTONE, S. R. Magnetos For Automobilists; How Made and How Used.**  
 A handbook of practical instruction on the manufacture and adaptation of the magneto to the needs of the motorist. *Second Edition, enlarged.* 52 illustrations. 12mo., cloth, 118 pp. . . . . Net, \$1.00
- Electric Motors, How Made and How Used.** Illustrated. 12mo., cloth, 168 pp. . . . . 75 cents
- BOWKER, WM. R. Dynamo, Motor, and Switchboard Circuits for Electrical Engineers: a practical book dealing with the subject of Direct, Alternating, and Polyphase Currents.** *Second Edition, greatly enlarged,* 130 illustrations. 8vo., cloth, 180 pp. . . . . Net, \$2.50
- CARTER, E. T. Motive Power and Gearing for Electrical Machinery; a treatise on the theory and practice of the mechanical equipment of power stations for electric supply and for electric traction.** *Second Edition, revised.* Illustrated. 8vo., cloth, 700 pp. . . . . Net, \$5.00
- CHILD, CHAS. T. The How and Why of Electricity: a book of information for non-technical readers, treating of the properties of Electricity, and how it is generated, handled, controlled, measured, and set to work. Also explaining the operation of Electrical Apparatus** Illustrated. 8vo., cloth, 140 pp. . . . . \$1.00
- CLARK, D. K. Tramways, Their Construction and Working.** *Second Edition.* Illustrated. 8vo., cloth, 758 pp. . . . . \$9.00
- COOPER, W. R. Primary Batteries: their Theory, Construction, and Use** 131 Illustrations. 8vo., cloth, 324 pp. . . . . Net, \$4.00
- The Electrician Primers.** Being a series of helpful primers on electrical subjects, for use of students, artisans, and general readers. *Second Edition.* Illustrated. Three volumes in one. 8vo., cloth. . Net, \$5.00
- Vol. I.—Theory.** . . . . . Net, \$2.00
- Vol. II.—Electric Traction, Lighting and Power.** . . . . . Net, \$3.00
- Vol. III.—Telegraphy, Telephony, etc.** . . . . . Net, \$2.00
- CROCKER, F. B. Electric Lighting. A Practical Exposition of the Art for the use of Electricians, Students, and others interested in the Installation or Operation of Electric-Lighting Plants.**
- Vol. I.—The Generating Plant.** *Seventh Edition, entirely revised.* Illustrated. 8vo., cloth, 482 pp. . . . . \$3.00
- Vol. II.—Distributing System and Lamps.** *Sixth Edition.* Illustrated 8vo., cloth, 505 pp. . . . . \$3.00
- CROCKER, F. B., and ARENDT, M. Electric Motors: Their Action, Control, and Application.** 160 illustrations. 8vo., cloth, 296 pp. . . . . Net, \$2.50

- CROCKER, F. B., and WHEELER, S. S.** *The Management of Electrical Machinery.* Being a *thoroughly revised and rewritten edition* of the authors' "Practical Management of Dynamos and Motors." *Seventh Edition.* Illustrated. 16mo., cloth, 232 pp. . . . . Net, \$1.00
- CUSHING, H. C., Jr.** *Standard Wiring for Electric Light and Power.* Illustrated. 16mo., leather, 156 pp. . . . . \$1.00
- DAVIES, F. H.** *Electric Power and Traction.* Illustrated. 8vo., cloth, 293 pp. (Van Nostrand's Westminster Series.) . . . . . Net, \$2.00
- DAWSON, PHILIP.** *Electric Traction on Railways.* 610 Illustrations. 8vo., half leather, 891 pp. . . . . Net, \$9.00
- DEL MAR, W. A.** *Electric Power Conductors.* 69 illustrations. 8vo., cloth, 380 pp. . . . . Net, \$2.00
- DIBDIN, W. J.** *Public Lighting by Gas and Electricity.* With many Tables, Figures, and Diagrams. Illustrated. 8vo., cloth, 537 pp. Net, \$8.00
- DINGER, Lieut. H. C.** *Handbook for the Care and Operation of Naval Machinery.* *Second Edition.* 124 Illustrations. 16mo., cloth, 302 pp. . . . . Net, \$2.00
- DYNAMIC ELECTRICITY:** Its Modern Use and Measurement, chiefly in its application to Electric Lighting and Telegraphy, including:  
 1. Some Points in Electric Lighting, by Dr. John Hopkinson. 2. On the Treatment of Electricity for Commercial Purposes, by J. N. Shoolbred. 3. Electric-Light Arithmetic, by R. E. Day, M.E. *Fourth Edition.* Illustrated. 16mo., boards, 166 pp. (No. 71 Van Nostrand's Science Series.) . . . . . 50 cents
- EDGCUMBE, K.** *Industrial Electrical Measuring Instruments.* Illustrated. 8vo., cloth, 227 pp. . . . . Net, \$2.50
- ERSKINE-MURRAY, J.** *A Handbook of Wireless Telegraphy: Its Theory and Practice.* For the use of electrical engineers, students, and operators. *Second Edition, revised and enlarged.* 180 Illustrations. 8vo., cloth, 388 pp. . . . . Net, \$3.50
- *Wireless Telephones and How they Work.* Illustrated. 16mo., cloth, 75 pp. . . . . \$1.00
- EWING, J. A.** *Magnetic Induction in Iron and other Metals.* *Third Edition, revised.* Illustrated. 8vo., cloth, 393 pp. . . . . Net, \$4.00
- FISHER, H. K. C., and DARBY, W. C.** *Students' Guide to Submarine Cable Testing.* *Third Edition, new, enlarged.* Illustrated. 8vo., cloth, 326 pp. . . . . Net, \$3.50

- LEMING, J. A., Prof.** The Alternate-Current Transformer in Theory and Practice.
- Vol. I.: The Induction of Electric Currents. *Fifth Issue.* Illustrated. 8vo., cloth, 641 pp. . . . . Net, \$5.00
- Vol. II.: The Utilization of Induced Currents. *Third Issue.* Illustrated. 8vo., cloth, 587 pp. . . . . Net, \$5.00
- Handbook for the Electrical Laboratory and Testing Room.** Two Volumes. Illustrated. 8vo., cloth, 1160 pp. Each vol. . . . . Net, \$5.00
- OSTER, H. A.** With the Collaboration of Eminent Specialists. Electrical Engineers' Pocket Book. A handbook of useful data for Electricians and Electrical Engineers. With innumerable Tables, Diagrams, and Figures. The most complete book of its kind ever published, treating of the latest and best Practice in Electrical Engineering. *sixth Edition, completely revised and enlarged.* Fully Illustrated. Pocket Size. Leather. Thumb Indexed. 1636 pp. . . . . \$5.00
- OWLE, F. F.** The Protection of Railroads from Overhead Transmission Line Crossings. 35 illustrations. 12mo., cloth, 76 pp. . . . . Net, \$1.50.
- ANT, L. W.** Elements of Electric Traction for Motormen and Others. Illustrated with Diagrams. 8vo., cloth, 217 pp. . . . . Net, \$2.50
- ERHARDI, C. H. W.** Electricity Meters; their Construction and Management. A practical manual for engineers and students. Illustrated. 8vo., cloth, 337 pp. . . . . Net, \$4.00
- ORE, GEORGE.** The Art of Electrolytic Separation of Metals (Theoretical and Practical). Illustrated. 8vo., cloth, 295 pp. . . . . Net, \$3.50
- RAY, J.** Electrical Influence Machines: Their Historical Development and Modern Forms. With Instructions for making them. *Second Edition, revised and enlarged.* With 105 Figures and Diagrams. 12mo., cloth, 296 pp. . . . . \$2.00
- ROTH, L. A.** Welding and Cutting Metals by Aid of Gases or Electricity. 124 illustrations. 8vo., cloth, 280 pp. . . . . Net, \$3.00
- HALLER, G. F. and CUNNINGHAM, E. T.** The Tesla High Frequency Coil; its construction and uses. 12mo., cloth, 56 illustrations, 130 pp. . . . . *In Press*
- LAMMER, W. J.** Radium, and Other Radio Active Substances; Polonium, Actinium, and Thorium. With a consideration of Phosphorescent and Fluorescent Substances, the properties and applications of Selenium, and the treatment of disease by the Ultra-Violet Light. With Engravings and Plates. 8vo., cloth, 72 pp. . . . . \$1.00

- HARRISON, N.** *Electric Wiring Diagrams and Switchboards.* Illustrated. 12mo., cloth, 272 pp. . . . . \$1.50
- HASKINS, C. H.** *The Galvanometer and its Uses. A Manual for Electricians and Students. Fifth Edition, revised.* Illustrated. 16mo., morocco, 75 pp. . . . . \$1.50
- HAWKINS, C. C., and WALLIS, F.** *The Dynamo: Its Theory, Design, and Manufacture. Fourth Edition, revised and enlarged.* 190 Illustrations. 8vo., cloth, 925 pp. . . . . \$3.00
- HAY, ALFRED.** *Principles of Alternate-Current Working. Second Edition.* Illustrated. 12mo., cloth, 390 pp. . . . . \$2.00
- Alternating Currents; their theory, generation, and transformation. Second Edition.* 191 Illustrations. 8vo., cloth, 319 pp. . . . . Net, \$2.50
- An Introductory Course of Continuous-Current Engineering.* Illustrated. 8vo., cloth, 327 pp. . . . . Net, \$2.50
- HEAVISIDE, O.** *Electromagnetic Theory. Two Volumes with Many Diagrams.* 8vo., cloth, 1006 pp. Each Vol. . . . . Net, \$5.00
- HEDGES, K.** *Modern Lightning Conductors. An illustrated Supplement to the Report of the Research Committee of 1905, with notes as to methods of protection and specifications.* Illustrated. 8vo., cloth, 119 pp. . . . . Net, \$3.00
- HOBART, H. M.** *Heavy Electrical Engineering.* Illustrated. 8vo., cloth, 338 pp. . . . . Net, \$4.50
- *Electricity. A text-book designed in particular for engineering students. 115 illustrations. 43 tables. 8vo., cloth, 266 pp., Net, \$2.00*
- HOBBS, W. R. P.** *The Arithmetic of Electrical Measurements. With numerous examples, fully worked. Twelfth Edition.* 12mo., cloth, 126 pp. . . . . 50 cents
- HOMANS, J. E.** *A B C of the Telephone. With 269 Illustrations.* 12mo., cloth, 352 pp. . . . . \$1.00
- HOPKINS, N. M.** *Experimental Electrochemistry, Theoretically and Practically Treated.* Profusely illustrated with 130 new drawings, diagrams, and photographs, accompanied by a Bibliography. Illustrated. 8vo., cloth, 298 pp. . . . . Net, \$3.00
- HOUSTON, EDWIN J.** *A Dictionary of Electrical Words, Terms, and Phrases. Fourth Edition, rewritten and greatly enlarged.* 582 Illustrations. 4to., cloth. . . . . Net, \$7.00
- A Pocket Dictionary of Electrical Words, Terms, and Phrases.* 12mo., cloth, 950 pp. . . . . Net, \$2.50



- HUTCHINSON, R. W., Jr.** **Long-Distance Electric Power Transmission:** Being a Treatise on the Hydro-Electric Generation of Energy; Its Transformation, Transmission, and Distribution. *Second Edition.* Illustrated. 12mo., cloth, 350 pp. . . . . Net, \$3.00
- HUTCHINSON, R. W., Jr. and IHLESEN, M. C.** **Electricity in Mining.** Being a theoretical and practical treatise on the construction, operation, and maintenance of electrical mining machinery. 12mo., cloth. . . . . *In Press*
- INCANDESCENT ELECTRIC LIGHTING.** A Practical Description of the Edison System, by H. Latimer. To which is added: The Design and Operation of Incandescent Stations, by C. J. Field; A Description of the Edison Electrolyte Meter, by A. E. Kennelly; and a Paper on the Maximum Efficiency of Incandescent Lamps, by T. W. Howell. *Fifth Edition.* Illustrated. 16mo., cloth, 140 pp. (No. 57 Van Nostrand's Science Series.) . . . . . 50 cents
- INDUCTION COILS: How Made and How Used.** *Eleventh Edition.* Illustrated. 16mo., cloth, 123 pp. (No. 53 Van Nostrand's Science Series.) . . . . . 50 cents
- JEHL, FRANCIS.** **The Manufacture of Carbons for Electric Lighting** and other purposes. Illustrated with numerous Diagrams, Tables, and Folding Plates. 8vo., cloth, 232 pp. . . . . Net, \$4.00
- JONES, HARRY C.** **The Electrical Nature of Matter and Radioactivity.** *Second Edition, revised and enlarged.* 12mo., cloth, 218 pp. . \$2.00
- KAPP, GISBERT.** **Electrical Transmission of Energy and its Transformation, Subdivision, and Distribution.** A Practical Handbook. *Fourth Edition, thoroughly revised.* Illustrated. 12mo., cloth, 445 pp. . \$3.50
- Alternate-Current Machinery.** Illustrated. 16mo., cloth, 190 pp. (No. 96 Van Nostrand's Science Series.) . . . . . 50 cents
- Dynamos, Alternators and Transformers.** Illustrated. 8vo., cloth, 507 pp. . . . . \$4.00
- KELSEY, W. R.** **Continuous-Current Dynamos and Motors, and their Control;** being a series of articles reprinted from the "Practical Engineer," and completed by W. R. Kelsey, B.Sc. With Tables, Figures, and Diagrams. 8vo., cloth, 439 pp. . . . . \$2.50
- KEMPE, H. R.** **A Handbook of Electrical Testing.** *Seventh Edition, revised and enlarged.* Illustrated. 8vo., cloth, 706 pp. . . Net, \$6.00

- KENNEDY, R. Modern Engines and Power Generators.** Illustrated. 8vo., cloth, 5 vols. Each. The set, \$15.00..... \$3.50  
**Electrical Installations of Electric Light, Power, and Traction Machinery.** Illustrated. 8vo., cloth, 5 vols. Each..... \$3.50
- KENNELLY, A. E. Theoretical Elements of Electro-Dynamic Machinery.**  
 Vol. I. Illustrated. 8vo., cloth, 90 pp..... \$1.50
- KERSHAW, J. B. C. The Electric Furnace in Iron and Steel Production.** Illustrated. 8vo., cloth, 74 pp..... Net, \$1.50  
**Electrometallurgy.** Illustrated. 8vo., cloth, 303 pp. (Van Nostrand's Westminster Series.)..... Net, \$2.00
- KINZBRUNNER, C. Continuous-Current Armatures; their Winding and Construction.** 79 Illustrations. 8vo., cloth, 80 pp..... Net, \$1.50  
**Alternate-Current Windings; their Theory and Construction.** 89 Illustrations. 8vo., cloth, 80 pp..... Net, \$1.50
- KOESTER, F. Hydroelectric Developments and Engineering.** A practical and theoretical treatise on the development, design, construction, equipment and operation of hydroelectric transmission plants. 500 illustrations. 4to., cloth, 475 pp..... Net, \$5.00
- **Steam-Electric Power Plants.** A practical treatise on the design of central light and power stations and their economical construction and operation. Fully Illustrated. 4to., cloth, 455 pp. Net, \$5.00
- LARNER, E.'T. The Principles of Alternating Currents for Students of Electrical Engineering.** Illustrated with Diagrams. 12mo., cloth, 144 pp..... Net, \$1.50
- LEMSTROM, S. Electricity in Agriculture and Horticulture.** Illustrated. 8vo., cloth..... Net, \$1.50
- LIVERMORE, V. P., and WILLIAMS, J. How to Become a Competent Motorman:** Being a practical treatise on the proper method of operating a street-railway motor-car; also giving details how to overcome certain defects. *Second Edition.* Illustrated. 16mo., cloth, 247 pp..... Net, \$1.00
- LOCKWOOD, T. D. Electricity, Magnetism, and Electro-Telegraphy.** A Practical Guide and Handbook of General Information for Electrical Students, Operators, and Inspectors. *Fourth Edition.* Illustrated. 8vo., cloth, 374 pp..... \$2.50

- JUDGE, OLIVER J.** Signalling Across Space Without Wires: Being a description of the work of Hertz and his successors. *Third Edition.* Illustrated. 8vo., cloth. . . . . Net, \$2.00
- DRING, A. E.** A Handbook of the Electro-Magnetic Telegraph. *Fourth Edition, revised.* Illustrated. 16mo., cloth, 116 pp. (No. 39 Van Nostrand's Science Series.) . . . . . 50 cents
- UPTON, A., PARR, G. D. A., and PERKIN, H.** Electricity Applied to Mining. *Second Edition.* With Tables, Diagrams, and Folding Plates. 8vo., cloth, 320 pp. . . . . Net, \$4.50
- AILLOUX, C. O.** Electric Traction Machinery. Illustrated. 8vo., cloth. . . . . *In Press*
- MANSFIELD, A. N.** Electromagnets: Their Design and Construction. *Second Edition.* Illustrated. 16mo., cloth, 155 pp. (No. 64 Van Nostrand's Science Series.) . . . . . 50 cents
- CASSIE, W. W., and UNDERHILL, C. R.** Wireless Telegraphy and Telephony Popularly Explained. With a chapter by Nikola Tesla. Illustrated. 12mo., cloth, 82 pp. . . . . Net, \$1.00
- LAURICE, W.** Electrical Blasting Apparatus and Explosives, with special reference to colliery practice. Illustrated. 8vo., cloth, 167 pp. . . . . Net, \$3.50
- **The Shot Firer's Guide.** A practical manual on blasting and the prevention of blasting accidents. 78 illustrations. 8vo., cloth, 212 pp. . . . . Net, \$1.50
- LAVER, WM., Jr.** American Telegraphy and Encyclopedia of the Telegraph Systems, Apparatus, Operations. *Fifth Edition, revised.* 450 Illustrations. 8vo., cloth, 656 pp. . . . . Net, \$5.00
- MONCKTON, C. C. F.** Radio Telegraphy. 173 Illustrations. 8vo., cloth, 272 pp. (Van Nostrand's Westminster Series.) . . . Net, \$2.00
- MORGAN, ALFRED P.** Wireless Telegraph Construction for Amateurs. 153 illustrations. 12mo., cloth, 220 pp. . . . . Net, \$1.50
- MUNRO, J., and JAMIESON, A.** A Pocket-Book of Electrical Rules and Tables for the Use of Electricians, Engineers, and Electrometallurgists. *Eighteenth Revised Edition.* 32mo., leather, 735 pp. . . . . \$2.50

- NIPHER, FRANCIS E.** *Theory of Magnetic Measurements.* With an Appendix on the Method of Least Squares. Illustrated. 12mo., cloth, 94 pp. ....\$1.00
- NOLL, AUGUSTUS.** *How to Wire Buildings. A Manual of the Art of Interior Wiring. Fourth Edition.* Illustrated. 12mo., cloth, 165 pp. ....\$1.50
- OHM, G. S.** *The Galvanic Circuit Investigated Mathematically.* Berlin, 1827. Translated by William Francis. With Preface and Notes by Thos. D. Lockwood. *Second Edition.* Illustrated. 16mo., cloth, 269 pp. (No. 102 Van Nostrand's Science Series.)..... 50 cents
- OLSSON, ANDREW.** *Motor Control as used in Connection with Turret Turning and Gun Elevating. (The Ward Leonard System.)* 13 illustrations. 12mo., paper, 27 pp. (U. S. Navy Electrical Series No. 1.).....Net, .50
- LOUDIN, MAURICE A.** *Standard Polyphase Apparatus and Systems. Fifth Edition, revised.* Illustrated with many Photo-reproductions, Diagrams, and Tables. 8vo., cloth, 369 pp. ....Net, \$3.00
- PALAZ, A.** *Treatise on Industrial Photometry.* Specially applied to Electric Lighting. Translated from the French by G. W. Patterson, Jr., and M. R. Patterson. *Second Edition.* Fully Illustrated. 8vo., cloth, 324 pp. ....\$4.00
- PARR, G. D. A.** *Electrical Engineering Measuring Instruments for Commercial and Laboratory Purposes.* With 370 Diagrams and Engravings. 8vo., cloth, 328 pp. ....Net, \$3.50
- PARSHALL, H. F., and HOBART, H. M.** *Armature Windings of Electric Machines. Third Edition.* With 140 full-page Plates, 65 Tables, and 165 pages of descriptive letter-press. 4to., cloth, 300 pp. ..\$7.50
- Electric Railway Engineering.* With 437 Figures and Diagrams and many Tables. 4to., cloth, 475 pp. ....Net, \$10.00
- Electric Machine Design.* Being a revised and enlarged edition of "Electric Generators." 648 Illustrations. 4to., half morocco, 601 pp. ....Net, \$12.50
- PERRINE, F. A. C.** *Conductors for Electrical Distribution: Their Manufacture and Materials, the Calculation of Circuits, Pole-Line Construction, Underground Working, and other Uses. Second Edition.* Illustrated. 8vo., cloth, 287 pp. ....Net, \$3.50

- POOLE, C. P.** *The Wiring Handbook with Complete Labor-saving Tables and Digest of Underwriters' Rules.* Illustrated. 12mo., leather, 85 pp. . . . . Net, \$1.00
- POPE, F. L.** *Modern Practice of the Electric Telegraph.* A Handbook for Electricians and Operators. *Seventeenth Edition.* Illustrated. 8vo., cloth, 234 pp. . . . . \$1.50
- RAPHAEL, F. C.** *Localization of Faults in Electric Light Mains.* *Second Edition, revised.* Illustrated. 8vo., cloth, 205 pp. . . . . Net, \$3.00
- RAYMOND, E. B.** *Alternating-Current Engineering, Practically Treated.* *Third Edition, revised.* With many Figures and Diagrams. 8vo., cloth, 244 pp. . . . . Net, \$2.50
- RICHARDSON, S. S.** *Magnetism and Electricity and the Principles of Electrical Measurement.* Illustrated. 12mo., cloth, 596 pp. . Net, \$2.00
- ROBERTS, J.** *Laboratory Work in Electrical Engineering—Preliminary Grade.* A series of laboratory experiments for first- and second-year students in electrical engineering. Illustrated with many Diagrams. 8vo., cloth, 218 pp. . . . . Net, \$2.00
- ROLLINS, W.** *Notes on X-Light.* Printed on deckle edge Japan paper. 400 pp. of text, 152 full-page plates. 8vo., cloth. . . . . Net, \$7.50
- RUHMER, ERNST.** *Wireless Telephony in Theory and Practice.* Translated from the German by James Erskine-Murray. Illustrated. 8vo., cloth, 224 pp. . . . . Net, \$3.50
- RUSSELL, A.** *The Theory of Electric Cables and Networks.* 71 Illustrations. 8vo., cloth, 275 pp. . . . . Net, \$3.00
- SALOMONS, DAVID.** *Electric-Light Installations.* A Practical Handbook. Illustrated. 12mo., cloth.
- Vol. I.: *Management of Accumulators.* *Ninth Edition.* 178 pp. \$2.50
- Vol. II.: *Apparatus.* *Seventh Edition.* 318 pp. . . . . \$2.25
- Vol. III.: *Application.* *Seventh Edition.* 234 pp. . . . . \$1.50
- SCELLEN, H.** *Magneto-Electric and Dynamo-Electric Machines.* Their Construction and Practical Application to Electric Lighting and the Transmission of Power. Translated from the Third German Edition by N. S. Keith and Percy Neymann. With Additions and Notes relating to American Machines, by N. S. Keith. Vol. I. With 353 Illustrations. *Third Edition.* 8vo., cloth, 518 pp. . . . . \$5.00

- SEVER, G. F.** *Electrical Engineering Experiments and Tests on Direct-Current Machinery. Second Edition, enlarged.* With Diagrams and Figures. 8vo., pamphlet, 75 pp. . . . . Net, \$1.00
- SEVER, G. F., and TOWNSEND, F.** *Laboratory and Factory Tests in Electrical Engineering. Second Edition, revised and enlarged.* Illustrated. 8vo., cloth, 269 pp. . . . . Net, \$2.50
- SEWALL, C. H.** *Wireless Telegraphy. With Diagrams and Figures. Second Edition, corrected.* Illustrated. 8vo., cloth, 229 pp. . Net, \$2.00
- Lessons in Telegraphy.* Illustrated. 12mo., cloth, 104 pp. . Net, \$1.00
- SEWELL, T.** *Elements of Electrical Engineering. Third Edition, revised.* Illustrated. 8vo., cloth, 444 pp. . . . . \$3.00
- The Construction of Dynamos (Alternating and Direct Current).* A Text-book for students, engineering contractors, and electricians-in-charge. Illustrated. 8vo., cloth, 316 pp. . . . . \$3.00
- SHAW, P. E.** *A First-Year Course of Practical Magnetism and Electricity.* Specially adapted to the wants of technical students. Illustrated. 8vo., cloth, 66 pp. interleaved for note taking. . . . . Net, \$1.00
- SHELDON, S., and HAUSMANN, E.** *Dynamo-Electric Machinery: Its Construction, Design, and Operation.*
- Vol. I.: *Direct-Current Machines. Eighth Edition, completely re-written.* Illustrated. 8vo., cloth, 310 pp. . . . . Net, \$2.50
- SHELDON, S., MASON, H., and HAUSMANN, E.** *Alternating-Current Machines: Being the second volume of "Dynamo-Electric Machinery; its Construction, Design, and Operation." With many Diagrams and Figures. (Binding uniform with Volume I.) Seventh Edition, rewritten.* 8vo., cloth, 353 pp. . . . . Net, \$2.50
- SLOANE, T. O'CONOR.** *Standard Electrical Dictionary.* 300 Illustrations. 12mo., cloth, 682 pp. . . . . \$3.00
- *Elementary Electrical Calculations.* A Manual of Simple Engineering Mathematics, covering the whole field of Direct Current Calculations, the basis of Alternating Current Mathematics, Networks, and typical cases of Circuits, with Appendices on special subjects. 8vo., cloth. Illustrated. 304 pp. . . . . Net, \$2.00
- SNELL, ALBION T.** *Electric Motive Power.* The Transmission and Distribution of Electric Power by Continuous and Alternating Currents. With a Section on the Applications of Electricity to Mining Work. *Second Edition.* Illustrated. 8vo., cloth, 411 pp. . . . . Net, \$4.00

- SODDY, F.** Radio-Activity; an Elementary Treatise from the Standpoint of the Disintegration Theory. Fully Illustrated. 8vo., cloth, 214 pp. . . . . Net, \$3.00
- SOLOMON, MAURICE.** Electric Lamps. Illustrated. 8vo., cloth. (Van Nostrand's Westminster Series.) . . . . . Net, \$2.00
- STEWART, A.** Modern Polyphase Machinery. Illustrated. 12mo., cloth, 296 pp. . . . . Net, \$2.00
- SWINBURNE, JAS., and WORDINGHAM, C. H.** The Measurement of Electric Currents. Electrical Measuring Instruments. Meters for Electrical Energy. Edited, with Preface, by T. Commerford Martin. Folding Plate and Numerous Illustrations. 16mo., cloth, 241 pp. (No. 109 Van Nostrand's Science Series.) . . . . . 50 cents
- SWOPE, C. WALTON.** Lessons in Practical Electricity: Principles, Experiments, and Arithmetical Problems. An Elementary Text-book. With numerous Tables, Formulæ, and two large Instruction Plates. *Eleventh Edition, revised.* Illustrated. 8vo., cloth, 462 pp. . . . . Net, \$2.00
- THOM, C., and JONES, W. H.** Telegraphic Connections, embracing recent methods in Quadruplex Telegraphy. 20 Colored Plates. 8vo., cloth, 59 pp. . . . . \$1.50
- THOMPSON, S. P.** Dynamo-Electric Machinery. With an Introduction and Notes by Frank L. Pope and H. R. Butler. Fully Illustrated. 16mo., cloth, 214 pp. (No. 66 Van Nostrand's Science Series.) . . . . . 50 cents
- Recent Progress in Dynamo-Electric Machines.** Being a Supplement to "Dynamo-Electric Machinery." Illustrated. 16mo., cloth, 113 pp. (No. 75 Van Nostrand's Science Series.) . . . . . 50 cents
- TOWNSEND, FITZHUGH.** Alternating Current Engineering. Illustrated. 8vo., paper, 32 pp. . . . . Net, 75 cents
- UNDERHILL, C. R.** Solenoids, Electromagnets and Electromagnetic Windings. 218 Illustrations. 12mo., cloth, 345 pp. . . . . Net, \$2.00
- URQUHART, J. W.** Dynamo Construction. A Practical Handbook for the use of Engineer Constructors and Electricians in Charge. Illustrated. 12mo., cloth. . . . . \$3.00

- Electric Ship-Lighting.** A Handbook on the Practical Fitting and Running of Ship's Electrical Plant, for the use of Ship Owners and Builders, Marine Electricians, and Sea-going Engineers in Charge. 88 Illustrations. 12mo., cloth, 303 pp. . . . . \$3.00
- Electric-Light Fitting.** A Handbook for Working Electrical Engineers, embodying Practical Notes on Installation Management. *Second Edition*, with additional chapters. With numerous Illustrations. 12mo., cloth. . . . . \$2.00
- Electroplating.** A Practical Handbook. *Fifth Edition.* Illustrated. 12mo., cloth, 230 pp. . . . . \$2.00
- Electrotyping.** Illustrated. 12mo., cloth, 228 pp. . . . . \$2.00
- WADE, E. J.** **Secondary Batteries: Their Theory, Construction, and Use.** *Second Edition, corrected.* 265 Illustrations. 8vo., cloth, 501 pp. Net, \$4.00
- WADSWORTH, C.** **Electric Battery Ignition.** 15 Illustrations. 16mo. paper . . . . . *In Press*
- WALKER, FREDERICK.** **Practical Dynamo-Building for Amateurs.** How to Wind for any Output. *Third Edition.* Illustrated. 16mo., cloth, 104 pp. (No. 98 Van Nostrand's Science Series.) . . . . 50 cents
- WALKER, SYDNEY F.** **Electricity in Homes and Workshops.** A Practical Treatise on Auxiliary Electrical Apparatus. *Fourth Edition.* Illustrated. 12mo., cloth, 358 pp. . . . . \$2.00
- Electricity in Mining.** Illustrated. 8vo., cloth, 385 pp. . . . . \$3.50
- WALLING, B. T., and MARTIN, JULIUS.** **Electrical Installations of the United States Navy.** With many Diagrams and Engravings. 8vo., cloth, 648 pp. . . . . \$6.00
- WALMSLEY, R. M.** **Electricity in the Service of Man.** A Popular and Practical Treatise on the Application of Electricity in Modern Life. Illustrated. 8vo., cloth, 1208 pp. . . . . Net, \$4.50
- WATT, ALEXANDER.** **Electroplating and Refining of Metals.** *New Edition*, rewritten by Arnold Philip. Illustrated. 8vo., cloth, 677 pp. . . . . Net, \$4.50
- Electrometallurgy.** *Fifteenth Edition.* Illustrated. 12mo., cloth, 225 pp. . . . . \$1.00



**WEBB, H. L.** A Practical Guide to the Testing of Insulated Wires and Cables. *Fifth Edition.* Illustrated. 12mo., cloth, 118 pp....\$1.00

**WEEKS, R. W.** The Design of Alternate-Current Transformer.  
*New Edition in Press*

**WEYMOUTH, F. MARTEN.** Drum Armatures and Commutators. (Theory and Practice.) A complete treatise on the theory and construction of drum-winding, and of commutators for closed-coil armatures, together with a full résumé of some of the principal points involved in their design, and an exposition of armature reactions and sparking. Illustrated. 8vo., cloth, 295 pp.....Net, \$3.00

**WILKINSON, H. D.** Submarine Cable Laying, Repairing and Testing. *Second Edition, completely revised.* 313 Illustrations. 8vo., cloth, 580 pp.....Net, \$6.00

**YOUNG, J. ELTON.** Electrical Testing for Telegraph Engineers. Illustrated. 8vo., cloth, 264 pp.....Net, \$4.00

**ZEIDLER, J., and LUSTGARTEN, J.** Electric Arc Lamps: Their Principles, Construction and Working. 160 Illustrations. 8vo., cloth, 188 pp.....Net, \$2.00



A 96-page Catalog of Books on Electricity, classified by subjects, will be furnished gratis, postage prepaid, on application.

7606







ok me. ... the d'

*[Handwritten scribble]*

*[Handwritten scribble]*

UNIVERSITY OF MICHIGAN



3 9015 00050 3469